



**ASSOCIATION INTERNATIONALE DE RADIODPROTECTION  
INTERNATIONAL RADIATION PROTECTION ASSOCIATION**

**IV<sup>e</sup> CONGRÈS INTERNATIONAL  
IVth INTERNATIONAL CONGRESS**

**RECUEIL  
DES COMMUNICATIONS**

VOLUME 1 - Lundi 25 avril

---

**PROCEEDINGS**

Monday April 25th

---

**PARIS 24-30 AVRIL 1977**



**ASSOCIATION INTERNATIONALE DE RADIOPROTECTION  
INTERNATIONAL RADIATION PROTECTION ASSOCIATION**

**IV CONGRÈS INTERNATIONAL  
IVth INTERNATIONAL CONGRESS**

# **SUBJECT INDEX**

---

**PARIS 24-30 AVRIL 1977**

## C O N T E N T S

---

A) METHODOICAL LIST OF THE SESSIONS BY GENERAL TOPICS	1
B) INDEX OF GENERAL TOPICS BY SESSIONS NUMBERS	3
C) INDEX OF SESSIONS BY KEY-WORDS	5
D) INDEX OF PAPERS BY KEY-WORDS	11

A) METHODOICAL LIST OF THE SESSIONS BY GENERAL TOPICS

GENERAL TITLE : RADIATION PROTECTION

I GENERAL PURPOSES	{	S01 and S08	: General aspects (part I and II)
		S04	: Comparison with other hazards
		S07	: Non ionizing radiation
		S13	: New ICRP recommendation
		S30	: Health implications (WHO)
		S29	: Education and Public information

II POPULATION EXPOSURE	{	Direct	S22	: Natural sources and consumer products
			S19 and P5	: Medical irradiation (Part I and II)
		Environmental effects	S02 and S20	: Environmental levels, limitation and control (Part I and II)
			S23	: Basic criteria for the limitation of releases (IAEA)
			S05	: Radioecology
			P3b	: Atmospheric dis- persion and doses
			P4c	: Fallout measure- ments

.../



III	WORKER'S EXPOSURE	{	S10 and P2a	: Personnel monitoring (Part I and II)
			S11 - S18 S27 and P2c	: Occupational radiation protec- tion : except fuel cycle - plants and reactors - medical uses
			S25	: Medical aspects of radiation protection
			S16	: Collective doses (UNSCEAR)
IV	BIOLOGY	{	S06	: Molecular and cellular radio- biology
			S24 and S28	: Experimental radiobiology (Part I and II)
			S09	: Assessments of organ doses
			S26 and P7	: Internal contamination (Part I and II)
			S14	: Radioprotectors
S17	: Effects in man ; risk estimates			
V	DOSIMETRY	{	S03	: General aspects and techniques
			P3a	: Physical aspects
			S15	: S.I. Units (ICRU)
			P1	: Instruments and techniques
			P6	: New techniques
			P4a	: Area and environmental monitoring techniques
P4b	: Neutron spectrometry			
VI	SPECIAL TOPICS	{	P2b	: Shielding and containment
			S12	: Wastes and decontamination
			S21	: Accidents

B) INDEX OF GENERAL TOPICS BY SESSIONS NUMBERS

<u>SESSION</u>		<u>GENERAL TOPIC</u>
P1	:	V Dosimetry
P2a	:	III Worker's Exposure
P2b	:	VI Special Topics
P2c	:	III Worker's Exposure
P3a	:	V Dosimetry
P3b	:	II Population Exposure
P4a	:	V Dosimetry
P4b	:	V Dosimetry
P4c	:	II Population Exposure
P5	:	II Population Exposure
P6	:	V Dosimetry
P7	:	IV Biology

.../

SESSION

GENERAL TOPIC

S01	:	I	General Purposes
S02	:	II	Population Exposure
S03	:	V	Dosimetry
S04	:	I	General Purposes
S05	:	II	Population Exposure
S06	:	IV	Biology
S07	:	I	General Purposes
S08	:	I	General Purposes
S09	:	IV	Biology
S10	:	III	Worker's Exposure
S11	:	III	Worker's Exposure
S12	:	VI	Special Topics
S13	:	I	General Purposes
S14	:	IV	Biology
S15	:	V	Dosimetry
S16	:	III	Worker's Exposure
S17	:	IV	Biology
S18	:	III	Worker's Exposure
S19	:	II	Population Exposure
S20	:	II	Population Exposure
S21	:	VI	Special Topics
S22	:	II	Population Exposure
S23	:	II	Population Exposure
S24	:	IV	Biology
S25	:	III	Worker's Exposure
S26	:	IV	Biology
S27	:	III	Worker's Exposure
S28	:	IV	Biology
S29	:	I	General Purposes
S30	:	I	General Purposes

.../

C) INDEX OF SESSIONS BY KEY-WORDS

ACCIDENT (radiation and nuclear) - S21  
ANIMAL biology - P7 - S14 - S24 - S28  
AREA monitoring - P4a  
ASSESSMENT (organ dose)- S09  
ATMOSPHERIC dispersion - P3b  
BIOLOGY - S06  
BIOLOGY (animal) - S14 - S24 - S28  
BIOLOGY (man) - P7 - S09 - S14 - S17 - S26  
CARCINOGENESIS - S28  
CELLULAR radiobiology - S06  
COLLECTIVE dose : UNSCEAR - S16  
COMPARISON of hazards - S04  
CONSUMER products irradiation - S22  
CONTAINMENT - P2b  
CONTAMINATION (internal) - P7 - S26  
CONTROL (medical) - S25  
CRITERIA (risk) - S01 - S08  
DECONTAMINATION - S12  
DEPOSITION model - P7 - S26  
DIFFUSION model - P3b  
DISPERSION (atmospheric)-P3b  
DOSE (collective) : UNSCEAR - S16  
DOSE (organ) - P7

.../

DOSE (organ) assessment - S09

DOSE (organ) from medical irradiation - P5

DOSIMETRY - P1 - P4a - P4b - P6 - S15

DOSIMETRY general aspects - S03

DOSIMETRY physical aspects - P3a

ECOLOGY - P4c - S02 - S05 - S20 - S22 -

EDUCATION - S29

EFFECT (radiation) in man - S17

EMERGENCY plan - S21

ENERGY production : WHO - S30

ENVIRONMENT - P4c - S02 - S20 - S22

ENVIRONMENTAL monitoring - P4a

EXPOSURE (collective) - S16

EXPOSURE (medical) - P5 - S19

EXPOSURE (population) - P3b - P4c - P5 - S02 - S05 - S19 - S20  
S22 - S23

EXPOSURE (worker's) - P2c - P2a - S10 - S11 - S16 - S18 - S25  
S27

FALL OUT measurement - P4c

GENERAL PURPOSES - S01 - S04 - S07 - S08 - S13 - S29 - S30

HAZARDS (comparison of) - 204

HAZARDS (non radioactive) - S04

HEALTH implication WHO - S30

HOSPITAL (occupational radiation protection in) - S11

HYGIEN (industrial) - S25

I.A.E.A. recommendation (limitation of releases) - S23

I.C.R.P. norm - S13

HEALTH (occupational) S25 .../

I.C.R.P. recommendation - S13  
I.C.R.U. - S15  
INCIDENT (radiation and nuclear) - S21  
INDUSTRIAL (hygien) - S25  
INFORMATION (public)- S29  
INJURY (radiation) - S21  
INSTRUMENTATION - P1 - P2a - P2b - P3a - P4a - P4b -  
P6 - S03 - S10  
INTERNAL contamination - P7 - S26  
IONIZING (non) radiation - S07  
IRRADIATION (medical) - P5 - S19  
LABORATORY (occupational radiation protection in) - S11  
LIMITATION of release : I.A.E.A. recommendation - S23  
MAN accidental contamination - S21  
MAN accidental irradiation - 21  
MAN biology - P7 - S09 - S14 - S17 - S26  
MAN (radiation effect in) - S17  
MODEL (deposition) - P7 - S26  
MEASUREMENT (fall out) - P4c  
MEASUREMENT (new techniques of) - P6  
MEASUREMENT techniques - P1  
MEASUREMENT techniques, general aspects - S03  
MEDICAL aspects of radiation protection - S25  
MEDICAL exposure - S19  
MEDICAL irradiation - P5 - S19  
MEDICAL use of radiation - P2c  
METABOLISM - P7 - S26

.../

MINES (occupational radiation protection in) - S18

MODEL (diffusion) - P3b

MOLECULAR radiobiology - S06

MONITORING - P2a - P3a - P4a - P6 - S10

MONITORING (environmental) - P4a

NATURAL source irradiation - S22

NON IONIZING radiation - S07

NON RADIOACTIVE hazard - S04

NORM (I.C.P.R.) - S13

NEUTRON spectrometry - P4b

NUCLEAR POWER PLANT (occupational radiation protection in) - S27

\*  
OCCUPATIONAL radiation protection in hospital - S11

OCCUPATIONAL radiation protection in laboratory - S11

OCCUPATIONAL radiation protection in mines - S18

OCCUPATIONAL radiation protection in nuclear power plant - S27

OCCUPATIONAL radiation protection in processing plant - S18

OCCUPATIONAL radiation protection in workroom - S11

OCCUPATIONAL radiation protection : medical use - P2c

OCCUPATIONAL radiation protection : miscellaneous - P2a - P2b -  
P2c

ORGAN dose - P7

ORGAN dose assessment - S09

ORGAN dose from medical irradiation - P5

PATIENT irradiation - P5

PLANT (occupational radiation protection in nuclear power) - S27

PLANT (occupational radiation protection in processing) - S18

POPULATION exposure - P3b - P4c - P5 - S02 - S05 - S19 - S20 -  
S22 - S23

\*  
OCCUPATIONAL health - S25

.../

PROCESSING PLANT (occupational radiation protection in) - S18  
PRODUCTS (consumer) irradiation - S22  
PUBLIC information - S29  
RADIATION (non ionizing) - S07  
RADIOBIOLOGY (cellular) - S06  
RADIOBIOLOGY (experimental) - S24 - S28  
RADIOBIOLOGY (molecular) - S26  
RADIOECOLOGY - P4c - S02 - S05 - S20 - S22  
RADIOPROTECTOR - S14  
REACTOR (occupational radiation protection in) - S27  
RECOMMENDATION (I.A.E.A.) limitation of release - S23  
RECOMMENDATION (I.C.R.P.) - S13  
RELEASE - S02 - S20  
RELEASE (atmospheric) - P3b  
RELEASE (limitation of) : I.A.E.A. recommendation - S23  
RISK (biological) estimate - S17  
RISK criteria - S01 - S08  
SHIELDING - P2b  
S.I. UNITS - S15  
SPECTROMETRY (neutron) - P4b  
TRAINING - S29  
TRANSPORT accident - S21  
UNITS (S.I.) - S15  
U.N.S.C.E.A.R. - S16  
WASTES - S12



WHO - S30

WORKER'S exposure - P2a - P2c - S10 - S11 - S16 - S18 - S25  
S27

WORKROOM (occupational radiation protection in) - S11

.../

D) INDEX OF PAPERS BY KEY-WORDS

Directions for use :

- I : General Purposes
- II : Population Exposure (included environmental effects)
- III : Worker's Exposure
- IV : Biology
- V : Dosimetry
- VI : Special Topics (Shielding - Wastes - Accidents)

S : Oral Session

P : Poster Session

The number printed immediately after the index of the session is the index n° of the paper.

Please then look at the paper index (in any of the four volumes) to find the volume and the page corresponding to the paper shown on the list.

For example, you look at : "DOSE distribution - II, S19 : "245". The number II means that the subject is included in a paper dealing with "population exposure", and "S19" means that paper 245 is included in session S19 ; then you look at the paper index : paper 245 is in volume 3, page 879.

.../

ABDOMEN - IV, S09 : 208

ABSORBED dose : see DOSE

ACCELERATORS, accident - III, P2a : 422

ACCELERATORS, Bremsstrahlung, X-rays - VI, P2b : 216

ACCELERATORS (electron linear) - V, P4b : 270

ACCELERATORS, shieldings - VI, P2b : 006 - 216  
V, P4b : 401

ACCIDENTS : see session S21

ACCIDENTS (accelerator) - III, P2a : 422

ACCIDENTS, dispersion models - II, P3b : 061

ACCIDENTS (professional) - I, S04 : 330

ACCIDENTS, atmospheric transfert evaluation - II, P3b : 354

ACCIDENTS (X-rays, gamma-rays) - III, S10 : 332

ACTIVATION (neutron flux) of compact bone - V, P1 : 233

A.C.T.H., radiosensibility - IV, S14 : 234

ACTINIDE (reirradiation of) - VI, S12 : 285

ACTINIUM - III, S18 : 339

ACUTE irradiation - IV, S24 : 433 - 437 - 438  
III, S25 : 327

ADMINISTRATIVE control - I, S08 : 407

AEROSOLS - III, S18 : 124

AEROSOLS, dose distribution - IV, P7 : 201

AEROSOLS, fast breeder reactor - IV, P7 : 062

AEROSOLS, lungs, animal - IV, P7 : 387

AEROSOLS, particle size - IV, P7 : 361

AEROSOLS, ventilation - III, S18 : 386

AIR monitoring - V, P4a : 174

AIR sampler - VI, S12 : 283

AIRBORNE, alpha particles - III, P2a : 385

AIRBORNE contamination - VI, S12 : 279

AIRBORNE, mining - III, S10 : 125 - 178

AIRBORNE radioactivity - II, P3b : 061

ALBEDO dosimeter energy independant - V, P1 : 246

ALGAE (concentration factor in) - II, S02 : 388

ALGAE (plutonium) and crustacean - II, S02 : 389

ALPHA and gamma contamination - VI, S21 : 358

ALPHA mixed irradiation - IV, S24 : 400

ALPHA particles - III, P2a : 385  
                  S10 : 125 - 178 - 252  
                  S18 : 386 - 427  
                  IV, S17 : 103  
                  VI, S21 : 288

ALPHA toxicity - IV, S28 : 342

ALUMINIUM oxides - V, P6 : 165 - 167

AMERICIUM 241 - II, P4c : 202  
                  S05 : 131  
                  IV, S24 : 89

ANIMALS, biological models - IV, S06 : 010

ANIMALS, carbon 14 - IV, S26 : 070

ANIMALS, chemical and radioactive toxicity - I, S04 : 489

ANIMALS, deposition model - IV, P7 : 201

ANIMALS, lung cancer - IV, S28 : 374

ANIMALS (extrapolation from) to man - IV, S28 : 084

ANIMALS, mineral water - II, S22 : 455

ANIMALS, platinumium 195 m - IV, P7 : 429

ANIMALS, plutonium - II, P4c : 202  
IV, S26 : 041 - 518

ANIMALS, radon products - IV, S26 : 106

ANIMALS, zinc 65, cadmium 109 - IV, P7 : 247

AREA dose : see DOSE

AREA monitoring - V, P4a : 171 - see also ENVIRONMENT

ARGON 41 : II, P3b : 286

ASH (slag - fly) : population exposure - V, P4a : 224

ASSESSMENT (dose) in fatal irradiation - VI, S21 : 457

ASSESSMENT of organ doses : see session S09

ATMOSPHERIC diffusion : see session P3b

ATMOSPHERIC pollution - I, S04 : 410

BACKGROUND radiation - II, S22 : 351  
V, P4a : 128 - 192 - 446  
P4c : 049

BENEFIT (cost) - I, S01 : 095 - 227 - 490  
II, P5 : 363

BENEFIT (risk) - II, S19 : 472  
S22 : 055

BERYLLIUM oxide - V, P6 : 122

BETA gamma counting - V, P4a : 446

BETA rays, absorbed dose distribution - III, P2a : 422

BETA rays, calibration - V, P1 : 350

BETA rays, dosimeter - V, P6 : 340

BETA rays, ions forming - V, P3a : 357

BETA rays rate meter - V, P1 : 119

BEZNAU - III, S27 : 148

BIOCHEMICAL dosimeter - V, P6 : 413

BIOLOGICAL dosimetry - III, S25 : 303

BIOLOGICAL effects of non ionizing radiations - I, S07 : 521 - 523

BIOLOGY : see list of the general topics

BITUMEN fixation - VI, S12 : 241

BLOOD forming organs - IV, S17 : 380

BODY activity - II, S22 : 017

BONE dose distribution - IV, S09 : 302

BONE marrow dose - II, P5 : 149

BONE (neutron flux activation of compact) - V, P1 : 233

BONE (plutonium 239) - IV, S26 : 518

BONNER spectrometer - V, P4b : 270 - 401

BREMSTRAHLUNG - V, P2b : 216

BUILDING materials - II, S22 : 207 - 351 - 419  
V, P4a : 224

BURIAL costs - VI, S12 : 279

B.W.R. - III, S18 : 124

CADMIUM 109, animal - IV, P7 : 247

CALCIUM (D.T.P.A.) - III, S25 : 333

CALCIUM fluoride - V, P6 : 371

CALCIUM sulphate - V, P6 : 164 - 165 - 340 - 371 - 423

CALIBRATION (beta rays) - V, P1 : 350

CALIBRATION - V, S03 : 166  
P4a : 171

CALIBRATION, standards - V, P3a : 032 - 058 - 156 - 334

CALIFORNIUM 152 - IV, S24 : 089

CANCER - II, S22 : 109  
IV, S06 : 309  
S17 : 096 - 103 - 155 - 228 - 467  
S28 : 342 - 343

CANCER (immunology and) - IV, S28 : 344 -

CANCER (lung) - IV, S28 : 344 - 374

CANCER mortality - I, S04 : 226

CANDU : tritium measurement - V, P4a : 174

CARBON 14 - II, S20 : 281 - 441

CARBON 14, animal, metabolism - IV, S26 : 070

CARBONATES (poly) - V, P6 : 159

CARCINOGENS (chemical) - I, S04 : 226

CELLS - IV, S06 : 010 - 309

CEMENTS (gypsum) - II, S22 : 059

CERAMIC filters - VI, S12 : 283

CEREAL contamination - II, S02 : 426

CERENKOV effect - V, P1 : 412

CERIUM, CESIUM, sediment absorption - II, S02 : 221

CESIUM 137 - II, S05 : 352

CHAMBER (ion) : see ION

CHELATION (plutonium) rate - III, S25 : 158

CHELATION, transuranium elements - III, S25 : 018

CHEMICAL carcinogens - I, S04 : 226

CHEMICAL hazards : see list of the general topics

CHEMICAL mutagenics - I, S04 : 050

CHEMICAL pollutants - I, S04 : 226

CHEMICAL (rem-equivalent for) toxicity - I, S04 : 016 - 050

.../

CHEMIOTOXIC effect equivalent - I, S04 : 251

CHILDREN - II, P5 : 250 - 370  
IV, S09 : 187 - 219

CHROMOSOMES aberrations : dose assessment - III, S25 : 402 - 435

CHROMOSOMES analysis (automatic) - V, P6 : 434

CHROMOSOMES, low doses - IV, S14 : 239

CHRONIC irradiation - IV, S24 : 346

CLEARANCE - V, P7 : 447

COBALT 58, metabolism, man - IV, P7 : 447

COBALT 60, metabolism - IV, P7 : 447

COLLECTIVE dose : see DOSE

COMBINATION (dose) : see DOSE

COMPACTION (waste) - VI, S12 : 279

COMPUTER, (gamma rays, luminescence) - III, S10 : 337

COMPUTER in survey instrument - V, P3a : 068

COMPUTER (mini) for radiation protection data - V, P1 : 481

COMPUTERIZED axial tomography - II, P5 : 404

CONCENTRATIONS factor - VI, S12 : 241

CONCENTRATIONS factor in algae - II, S02 : 388

CONCENTRATIONS (maximum allowable) - I, S04 : 050

CONCENTRATIONS (threshold) - I, S04 : 489

CONTAMINATED wound - VI, S21 : 358

CONTAMINATION (alpha and gamma emitters) - VI, S21 : 358

CONTAMINATION (fission product) - VI, S21 : 289

CONTAMINATION by inhalation - VI, S21 : 359

CONTAMINATION (internal) IV, S09 : 063 - 219  
V, P3a : 462  
VI, S21 : 288

.../



CONTAMINATION (internal) personnel dosimeter - III, P2a : 432  
CONTAMINATION (internal) whole-body dosimeter - III, P2a : 284  
CONTAMINATION (milk) - II, S02 : 184  
V, P4a : 446  
CONTAMINATION (natural) inside buildings - II, S22 : 207  
CONTAMINATION, plant - III, S18 : 012 - 110  
CONTAMINATION (population) - VI, S21 : 036  
CONTAMINATION (prediction of), food chain - II, S02 : 392 - 426  
CONTAMINATION (soil) - II, P4c : 138 - 145  
CONTAMINATION (surface) - V, P4a : 254  
VI, S12 : 242  
CONTAMINATION (water) - V, P4a : 473  
CONTROLS (administrative) - I, S08 : 407  
V, S03 : 135  
CONTROLS in industry - II, S22 : 055 - 059  
CONVERSION factors - V, P4a : 192  
CONVERSION relations - V, P4b : 355  
CONVERTER DC to frequency - V, P1 : 381  
COOLING time - VI - S12 : 285  
COOLING tower, environment - II, S02 : 184  
COSMIC protons - IV, S17 : 380  
COST/benefit - I, S01 : 095 - 227 - 490  
II, P5 : 363  
COUNTER (BF3) - V, P1 : 118  
COUNTER (GM) - V, P4a : 171  
COUNTER (thermal neutron rem) - V, P1 : 377  
CRITICALITY dosimetry - V, P1 : 415  
V, S03 : 484  
CRITICALITY, plant - III, S18 : 012

.../

CROPS - II, S05 - 391

CRYSTAL (spherical) - V, P4a : 192

CRYSTALLOGRAPHY X-rays : protection - III, S11 : 072

DAMAGE (radiation) - I, S01 : 428 - 451

DEATHES (worker) statistics - I, S04 : 330

DECOMMISSIONING - III, S18 : 339 - 466

DECONTAMINATION factor - VI, S12 : 241

DECONTAMINATION gels and mixtures - VI, S12 : 242

DECONTAMINATION (internal) - IV, S24 : 089

DECONTAMINATION (nuclear equipments) - III, S27 : 525

DECONTAMINATION (nuclear power plant) - III, S27 : 293

DECONTAMINATION process - VI, S12 : 242

DECONTAMINATION (skin) - III, S25 : 231

DEPOSITION models : see sessions S26 and P7

DESIGN aspects , eyes protecting - VI, P2b : 040

DESIGN aspects, glove box - VI, P2b : 526

DESIGN (radiological) aspects - I, S08 : 407

DETECTORS : see DOSIMETRY or DOSIMETER (v)

DIAGNOSTIC (medical) - IV, S09 : 071 and II, session P5, most  
II, S19 : 210 of the papers

DIFFUSION (atmospheric) : see session P3b

DISEASES (professional) - I, S04 : 330

DISPERSION (atmospheric) : see session P3b

DISTRIBUTION (dose) : see DOSE

D.N.A. chain-break - IV, S06 : 301

D.N.A. molecular action - IV, S14 : 383

.../

D.N.A. membrane - enzymatic system - IV, S14 : 236

D.N.A. replication - IV, S06 : 141

DOSE (absorbed) - II, P3b : 286  
P5 : 230  
III, S16 : 515  
IV, S09 : 187 - 219 - 292 - 476  
V, P3a : 462

DOSE (absorbed), bêta - V, P1 : 119

DOSE (absorbed) from neutron - V, P4b : 214

DOSE (absorbed), gamma - V, S03 : 356

DOSE (absorbed), luminescence - III, P2a : 398

DOSE (absorbed), skin - III, P2c : 461

DOSE (area) - V, S03 : 291

DOSE assessment - II, S05 : 295 - 391

DOSE assessment in fatal irradiation - VI, S21 : 457

DOSE assessment (plutonium) - IV, S26 : 518

DOSE calculation models - II, P3b : 282 - 294

DOSE : chromosome aberrations - III, S25 : 435

DOSE (collective) - I, S01 : 095 - 305 - 408  
II, S20 : 151 - 179 - 280 - 281 - 287 - 441  
479  
P3b : 403

DOSE (collective), UNSCEAR - III, S16 : 515

DOSE combination practic - I, S08 : 452

DOSE (combination) index - IV, S09 : 134

DOSE (deep) build up - V, P1 : 412

DOSE distribution - II, S19 : 245  
IV, S09 : 071 - 134 - 208 - 261 - 313  
S17 : 037  
V, P4b : 401

DOSE distribution (aerosols inhalation) - IV, P7 : 201

.../



DOSE (organ), assessment : see session S09

DOSE (organ), assessment, accident - VI, S21 : 311

DOSE (organ), bone marrow - II, P5 : 149

DOSE (organ), gonads - II, P5 : 150 - 209 - 250 - 370

DOSE (organ), ovaries - II, P5 : 244

DOSE (organ), skin - II, P5 : 250

DOSE (organ), uterus - II, S19 : 444

DOSE (population) - II, S20 : 151 - 177 - 206 - 278 - 280 - 287  
367 - 409

DOSE quantity for standardization - V, S03 : 384

DOSE (radiological) - I, S01 : 305

DOSE (radon inhalation) - IV, S26 : 106

DOSE rate - IV, S28 : 264

DOSE rate (automate) : electrometer - V, P1 : 381

DOSE rate, equivalent - V, P4a : 192

DOSE rate (neutron) - V, P1 : 118

DOSE register, computer (personal) - III, S10 : 034

DOSE response - V, PJa : 114  
P6 : 413

DOSE response, cellular biology - IV, S06 : 010 - 142 - 309

DOSE (threshold) - I, S01 : 095 - 428 - 490

DOSIMETER (albedo) energy independant - V, P1 : 246

DOSIMETER (biochemical) - V, P6 : 413

DOSIMETER (insulating foil) - V, P6 : 129 - 159

DOSIMETER (personnel), internal contamination - III, P2a : 432

DOSIMETER (glass (R.P.L.)) - V, P6 : 338

DOSIMETER (reusable) - V, S03 : 135

.../

DOSIMETRY : see Index of sessions

DOSIMETRY (biological) - III, S25 : 303

DOSIMETRY (criticality) - V, P1 : 415  
SO3 : 484

DOSIMETRY (individual administrative) - I, SO8 : 099

DOSIMETRY, nuclear power plant - III, S27 : 293

DOSIMETRY (personnel): gynecological applications - III, S11 : 300

D.T.P.A. - IV, S24 : 089

D.T.P.A./calcium - III, S25 : 333

D.T.P.A./zinc - III, S25 : 333

D.T.P.A. removal efficiency - III, S25 : 260

DUST collector - VI, S12 : 283

ECOLOGICAL studies : see Index of sessions

EDUCATION : see List of the general topics I - session S29

EDUCATION and training - II, P5 : 420

EFFICIENCY (calculation of) - V, P6 : 168

ELECTROMAGNETIC field : see FIELD

ELECTROMETER (automatic dose rate) - V, P1 : 381

ELECTRONS - IV, SO9 : 253

ELECTRONS (exo) : see EXOELECTRONS

ELECTRONS (high energy) - II, P5 : 150

ELECTRONS linear accelerator - V, P4b : 270

ELECTRONS (bêta particles) - V, P3a : 357

EMERGENCY dose limit - VI, S21 : 288

EMERGENCY plan - VI, S21 : 364

.../

ENERGY production, health - I, S30 : 319

E.N.D.I.P. - V, S03 : 356

ENVIRONMENT : see List of the general topics II and  
Index of sessions

ENVIRONMENT - VI, S12 : 283

ENVIRONMENTAL contamination - II, S05 : 298

ENVIRONMENTAL monitoring - II, S05 : 403  
V, P3a : 334

ENVIRONMENTAL pathway - II, S20 : 177

ENVIRONMENTAL radiation - V, P6 : 164 - 338 - 371  
S03 : 220

ENVIRONMENT (aquatic) - II, S05 : 131 - 295

ENVIRONMENT (fuel reprocessing plant) - II, S02 : 389

ENVIRONMENT (mathematical model) - II, S02 : 426

ENVIRONMENT, nuclear power plant - III, S27 : 148

ENVIRONMENT transfert, radionuclides - II, S02 : 392

ENZYMATIC system - IV, S14 : 222 - 236

EVAPORATION (liquids waste) - VI, S12 : 241

ERYTHROCYTES - IV, S24 : 433

ESCHERICHIA coli - IV, S06 : 142

ETCHING - V, P6 : 159

EUROPEAN COMMUNITY - V, S03 : 379

EXCRETION (plutonium 239) - IV, P7 : 361

EXCRETION (protactinium 231 and products) - IV, P7 : 093

EXCRETION, radon daughters - III, S18 : 154

EXOLECTRON (T.S.E.E.) - V, P6 : 122 - 167

EXPOSURE (medical) : see MEDICAL

EXPOSURE (occupational) : see OCCUPATIONAL

EXPOSURE (patient) - II, P5 : 195 - 263 - 363 - 416 - 449  
S19 : 104

EXPOSURE (population) : see POPULATION

EXTRAPOLATION from animal to man - IV, S28 : 084

EYES protecting - VI, P2b : 040

FALL-OUT : see Index of sessions and session P4c

FALL-OUT dose in man - IV, P7 : 029

FEATURES protective - I, S08 : 407

FERTILIZERS (phosphate) - II, S22 : 113 - 315

FIELD (electromagnetic) measurement - I, S07 : 025 - 304 - 485  
524

FIELD (mixed radiation) : see MIXED

FILM dosimeter - III, S10 : 337 : see also List of the general  
topics (V)

FILM (gamma rays) - III, P2c : 185

FILM, radiotoxicology, internal contamination - III, P2a : 258

FILTERS (ceramic) - VI, S12 : 283

FILTERS bank - VI, S12 : 279

FILTRATION, iodine, testing - II, S20 : 366

FISSION product ground contamination - VI, S21 : 289

FOETUS - II, P5 : 230 - 248  
S19 : 210  
IV, S09 : 208

FOGGINESS effect, wastes - II, S02 : 184

FOOD chain - II, P4c : 085 - 202 - 205 - 276  
S02 : 426  
S05 : 352  
S20 : 179 - 278  
S22 : 113 - 411 - 455

.../



FUEL processing and reprocessing : see PLANT

FUEL (fossil) power plants - I, S04 : 410

GAMMA (alpha and) emitters contamination - VI, S21 : 358

GAMMA (bêta) counting - V, P4a : 446

GAMMA dose - V, S03 : 356

GAMMA (low energy) detector - V, P3a : 116

GAMMA RAYS, cellular biology - IV, S06 : 235

GAMMA RAYS, film - III, P2c : 185

GAMMA RAYS, legal aspects - III, S10 : 337

GAMMA RAYS, luminescence - III, S10 : 337

GAMMA RAYS measurement - IV, S06 : 142 - 309

SO9 : 253 - 292 - 313

V, P4a : 128 - 171 - 192

GAMMA RAYS, mines - III, S18 : 022

GAMMA RAYS, X-rays, accident - III, S10 : 332

GAZEOUS discharges from nuclear power plants - I, S04 : 410

GAZEOUS effluents - II, P3b : 060 - 100 - 160 - 161 - 186 - 421

GASTROINTESTINAL syndrom - IV, S24 : 438

GASTROINTESTINAL system, recovery - IV, S14 : 238

GENERAL purposes : see List of the general topics

GENERAL purposes (medical exposure) - II, S19 : 516

GENETIC effects, non ionizing radiation - I, S07 : 182

GLASS (R.P.L.) dosimeter - V, P6 : 338

GONADS dose - II, P5 : 150 - 209 - 250 - 370

GRAFT (intestinal) - IV, S24 : 438

.../

GROUND water contamination - II, S05 : 299  
S22 : 397

GROUND (fission product) contamination - VI, S21 : 289

G.S.F. - V, S03 : 356

GUNDREMMINGEN - III, S27 : 188

GYPNUM cements - II, S22 : 059

HAEMOPOIETIC system recovery - IV, S14 : 238

HAND (kilo-rad irradiation of a) - VI, S21 : 213

HEALTH, energy production - I, S30 : 519

HIGH ENERGY electrons - II, P5 : 150

HIGH ENERGY X-rays - II, P5 : 150  
V,P4b : 270

HISTOPATHOLOGY - IV, S28 : 342

HORMONES, radiosensibility - IV, S14 : 234

HOSPITAL personal dosimetry - III, S11 : 300

HOUSEHOLD water - II, S22 : 397

I.A.E.A. - V, S03 : 484

I.A.E.A., recommendations for releases - II, S23 : 517

I.C.R.P. - IV, S09 : 253

I.C.R.P., new recommendations - I, S13 : 513

I.C.R.U., S.I. units - V, S15 : 514

IMMUNOLOGY - IV - S24 : 437  
S28 : 344

INCIDENT - II, S05 : 299

INCIDENT (nuclear weapon) - II, P4c : 138

INCINERATOR (waste) - VI, S12 : 283

INDEX (dose), combination : see DOSE

INDUSTRIAL radiography - VI, S21 : 183

INDUSTRY (contrôls in) - II, S22 : 055 - 059

INDUSTRY (phosphate) - II, S22 : 109

INFORMATION : see List of the general topics (I)  
session S29

INHALATION, monitoring - III, S10 : 252  
S18 : 110 - 154  
IV, P7 : 201 - 223 - 361  
S17 : 103  
S26 : 106  
S28 : 344  
VI, S21 : 359

INSTRUMENTATION : see Index of sessions

INTERCOMPARISON - V, S03 : 379 - 484

INTERNAL contamination - II, S02 : 392  
IV, S09 : 063 - 219  
S26 : 518  
VI, S21 : 288

INTERNAL contamination, incident - V, P7 : 447

INTERNAL decontamination - IV, S24 : 089

INTERNATIONAL cooperation - II, S05 : 483

INTERNATIONAL coordinated research - V, S03 : 484

INTESTINAL transplantation - IV, S24 : 438

IODINE - II, S20 : 151  
V, P4a : 446

IODINE 123 - IV, S09 : 063

IODINE 129 - II, S02 : 426  
IV, S09 : 261

IODINE 130 to 135 - IV, S09 : 219

IODINE 131 - II, S19 : 066 - 444  
IV, S09 : 063

.../

IODINE behaviour in nuclear accident - VI, S21 : 372

IODINE releases - II, S02 : 184

IODINE (ventilation, filtration), testing - II, S20 : 366

ION chamber - II, P5 : 209  
V, P1 : 350  
P3a : 156 - 357  
P4a : 174  
S03 : 220

IRRADIATION (acute) - III, S25 : 327  
IV, S24 : 433 - 437 - 438

IRRADIATION (dose assessment in fatal) - VI, S21 : 457

IRRADIATION (kilo-rad) of a hand - VI, S21 : 213

IRRADIATION, plant - III, S18 : 012

IRRADIATION (prenatal) - IV, S06 : 141

IRRIGATION - II, S05 : 391

KERMA - V, P4b : 355

KIDNEY - IV, S24 : 400

K TRANSPORT, cellular biology - IV, S06 : 235

LABORATORY (mining) - III, S18 : 386

LABORATORY (mobile) for dosimetry - V, P4a : 128

LAND (reclaimed)- II, S22 : 065 - 109

LASERS - I, S07 : 130 - 182  
III, S11 : 108  
IV, S09 : 476

LATENT period - IV, S06 : 141

LEGAL aspects - III, S10 : 337  
VI, S21 : 024

LEUKAEMIA - IV, S06 : 141  
S17 : 335 - 467

LICHENS (food chains) - II, P4c - 085

LIFESPAN - IV, S24 : 229 - 346  
S28 : 343

LIMITATION of releases : see Index of sessions

LIMITS (operative) - II, S22 : 411

LINEAR hypothesis - I, S01 : 428 - 451

LITHIUM borate - V, P6 : 340

LITHIUM FLUORIDE - V, P6 : 165 - 307 - 340 - 371

LITHIUM sulphate - V, P6 : 423

LIVER (plutonium 239) IV, S26 : 041

LONG LIFE radioisotopes - II, S05 : 193

LONG LIFE wastes - VI, S12 : 512

LOW dose : see DOSE

LOW dose (chromosomes) - IV, S14 : 239

LOW energy gamma detector - V, P3a : 116

LOW energy photon - IV, S09 : 057

LOW LEVEL activity wastes - VI, S12 : 283

LOW LEVEL (skin effects) irradiation - III, S25 : 218

LUMINESCENCE, absorbed dose, operating - III, P2a : 398

LUMINESCENCE, (gamma rays) - III, S10 : 337

LUMINESCENCE (lyo-) dosimeter - V, P6 : 176 - 413 - 414

LUMINESCENCE (thermo) - I, S07 : 418  
II, S19 : 245 - 444  
S22 : 351  
P5 : 044 - 083 - 370  
V, S03 : 135 - 220  
P3a : 334  
P4b : 270  
P6 : 105 - 163 - 164 - 168 - 307 - 338  
340 - 371

.../

LUMINESCENCE, whole body dosimetry - III, S10 : 137

LUMINESCENT (thermo-) materials - V, P6 : 165

LUMINOUS paints - II, S22 : 055  
III, S11 : 255

LUNG cancer - IV, S28 : 343 - 344 - 374

LUNG cells targets - IV, S28 : 342

LUNG (plutonium), dose prediction - II, S02 : 067 - 120  
IV, S09 : 057 - 187  
S17 : 103 - 228  
S24 : 400  
P7 : 387  
V, P3a : 116 - 462

LUNG, radon - IV, S26 : 106

LYMPHOCYTES - IV, S24 : 437

LYOLUMINESCENCE : see LUMINESCENCE

LYSOPHOSPHOLIPIDS - IV, S06 : 235

MAGNOX reactor - II, P3b : 286

MAMMALIAN CELLS vitamine C - IV, S14 : 011

MAN (cobalt 58, metabolism) - IV, P7 : 447

MAN (fall out dose in) - IV, P7 : 029

MAN (natural radioactivity, metabolism) - IV, P7 : 093

MAN (plutonium 239), injection - IV, P7 : 191

MAN (standard) - II, S05 : 391

MAN (tellurium isotopes), metabolism - IV, S26 : 318

MARINE pollution - II, P4c : 138 - 205

MARROW (bone) dose - II, P5 : 149

MATERIALS (building) - II, S22 : 351 - 419  
V, P4a : 224

MATERIALS (thermoluminescent) : see LUMINESCENT

MATHEMATICAL model : see MODEL

MAXIMUM allowable concentrations - I, S04 : 050

MEASUREMENT (dose) : see DOSE

MEASUREMENT (electromagnetic field) : see FIELD

MEASUREMENT (gamma rays) : see GAMMA rays

MEDICAL ASPECTS - III, P2c : 185 - 274 - 461

MEDICAL exposure, general purposes - II, S19 : 516  
see also EXPOSURE

MEDICAL treatment after acute irradiation - III, S25 : 327

MEDICINE (nuclear) - II, P5 : 420

MEDIUM (saturated porous) - II, S05 : 193

MEDULLARY restoration - IV, S24 : 433

MEMBRANES (arteficial) - IV, S06 : 235

METABOLIC studies : see sessions S26 and P7

MICROPROCESSORS - V, P1 : 320  
P6 : 105

MICROWAVES - I, S07 : 130 - 182 - 304 - 523

MILK contamination - II, S02 : 184  
V, P4a : 446

MINERAL water, animals - II, S22 : 455

MINING - III, S10 : 125 - 178  
S18 : 154 - 427  
IV, S17 : 228

MINING - high-grade ore - III, S18 : 022

MINING, laboratory - III, S18 : 386

MINING : population exposure - II, S22 : 065  
V, P4a : 473

MITOCHONDRIAE - IV, S06 : 235

MITOTIC activity - IV, S24 : 237

.../

MIXED radiation fields - V, P6 : 423  
S03 : 291 - 356

MODELS (mathematical) shielding - VI, P2b : 216

MODELS (mathematical) - II, P3b : 160 - 294 - 354 - 403  
S02 : 426  
S05 : 193  
III, S10 : 178  
IV, S06 : 010 - 141  
S09 : 071 - 134 - 302  
S17 : 037  
P7 : 201 - 223 - 387

MOLECULAR action (radioprotector - D.N.A.) - IV, S14 : 383

MONITORING (personnel) : see session S03

MONITORING (inhalation) - III, S10 : 252

MONITORING (environmental) - II, S05 : 483  
V, P3a : 334

MUTAGENICS (chemical) - I, S04 : 050

NATURAL dose - I, S01 : 305

NATURAL radioactivity : see Index of sessions and session S22

NATURAL radioactivity, dose distribution - IV, P7 : 029 - 093

NATURAL radionuclides - V, P4a : 224 - 473  
P4c : 049

NEUTRONS - IV, S09 : 476  
S17 : 335 - 467  
V, S03 : 379  
P1 : 118 - 233 - 306 - 377 - 415  
P3a : 087 - 114 - 357  
P6 : 129 - 159 - 165 - 176 - 307

NEUTRONS, dose equivalent - VI, P2b : 172

NEUTRONS, energy response - VI, P2b : 216

NEUTRONS fluence - V, P4b : 214

NEUTRONS (shielding) - VI, P2b : 006

NEUTRONS spectrometry - V, P4b : 214 - 270 - 355 - 401



NON IONIZING radiations : see session S07

NORM : see Index of sessions

NRX - III, S27 : 175

NUCLEAR energy, health - I, S30 : 519

NUCLEAR equipments decontamination - III, S27 : 525

NUCLEAR medicine - II, P5 : 420

NUCLEAR power plant : see S20 and S27 and  
II P3b : 061 - 286  
III, S18 : 124 - 466  
V, P3a : 068

NUCLEAR power plant (releases from) , II, S02 : 341 - 426 - 431

NUCLEAR power plant, training - I, S29 : 463

NUCLEAR weapons - II, P4c : 085 - 138 - 205

OCCUPATIONAL dose : see DOSE

OCCUPATIONAL exposure - I, S07 : 025 - 485  
II, S19 : 066  
S20 : 479  
IV, S17 : 228  
V, P7 : 447

OCCUPATIONAL exposure (medical aspects) - III, P2c : 274

OCCUPATIONAL exposure, regulation - III, S27 : 316

OCCUPATIONAL health : see Index of sessions (INDUSTRIAL hygien)

OCCUPATIONAL radiation protection : see list of the general topics  
(WORKERS exposure)

OPERATIONAL health physics - V, P3a : 068

ORGAN dose : see DOSE

OSTEOSARCOMA - IV, S28 : 264

OVARIES dose - II, P5 : 244

.../



PLANT (nuclear processing or reprocessing) - II, S02 : 389  
S20 : 179 - 280  
281  
III, S18 : 012 - 110  
466

PLANT (processing) dosimeter - V, P1 : 306

PLATINIUM 195 m metabolism - IV, P7 : 429

PLUTONIUM - IV, S09 : 057  
S28 : 084 - 344

PLUTONIUM, accident - VI, S21 : 359

PLUTONIUM, actinides nuclear power plant - II, S02 : 341

PLUTONIUM fall out : see Session P4c

PLUTONIUM fuel fabrication - III, S18 : 012 - 110

PLUTONIUM in algae and crustacean - II, S02 : 389

PLUTONIUM, lung - V, P3a : 462

PLUTONIUM, lung, dose prediction - II, S02 : 067 - 120

PLUTONIUM metabolism : see sessions S26 and P7

PLUTONIUM processing area - III, S18 : 124

PLUTONIUM rates chelation - III, S25 : 158

PLUTONIUM, solid wastes - V, P1 : 393

PLUTONIUM (surface contamination) - II, S02 : 067

POLLUTION (marine) - II, P4c : 138 - 205

POLLUTION (atmospheric) - I, S04 : 410

POLLUTANTS (chemical) - I, S04 : 016 - 226

POPULATION contamination - II, P5 : 149  
VI, S21: 036

POPULATION exposure : see List of the general topics and  
I, S07 : 304  
IV, S17 : 335 - 467

POPULATION information - I, S29 : 086 - 425

.../

POTASSIUM - II, S22 ; 017

POTENTIALIZATION effect - IV, S24 : 400

PRACTICE (dose combination) - I, S08 : 452

PREGNANT woman - IV, S09 : 208

PROFESSIONAL accidents - I, S04 : 330

PROFESSIONAL diseases - I, S04 - 330

PROTACTINIUM 231 and products, excretion - IV, P7 - 093

PROTONS (cosmic) - IV, S17 : 380

PSYCHOSOCIOLOGY - I, S29 : 425

PUBLIC information : see List of the general topics

P.W.R. decontamination - III, S27 : 525

QUALITY factors - V, P4b : 270

RADIATION (background) - V, P4a : 128 - 192

RADIATION fields (mixed) : see MIXED

RADIATION (non-ionizing) : see session S07

RADIATION (skyshine) - V, P2b : 216

RADIATION waste - V, P4a : 128

RADICALS (free) from chemical pollutants - I, S04 : 016

RADIOCHEMICAL procedures - II, P4c : 049 - 202 - VI<sup>1</sup>, S12 : 241

RADIOFREQUENCY radiation - I, S07 : 025 - 304 - 485 - 523 - 524

RADIOGRAPHY (industrial) - VI, S21 : 183

RADIONUCLIDE toxicity - IV, S28 : 084

.../

RADIOPROTECTORS : see session S14 and  
IV, S06 : 301

RADIOSENSIBILITY - A.C.T.H. - IV, S14 : 234

RADIUM - II, S22 : 017 - 113 - 455  
III, S18 : 339

RADIUM 224 - IV, S28 : 084 - 264

RADIUM 226 - IV, S28 : 264

RADIUM refining - II, S22 : 411

RADIUM retention - IV, S09 : 302

RADON - II, S22 : 059 - 109 - 397  
III, S18 : 154  
IV, S09 : 187  
S28 : 374  
V, P4a : 224

RADON 222 and daughters - II, S22 : 207  
IV, S26 : 106

RADON daughters - V, P1 : 091 - 162

RAMSAR site Iran - II, S22 : 455

R.B.E. - I, S04 : 489  
IV, S17 : 467  
S24 : 229

REACTORS core (fast) - VI, S12 : 285

REACTORS: see NUCLEAR power plant

READER (automatic) - V, P6 : 105 - 163 - 307

RECOMMENDATIONS, I.A.E.A., releases - II, S23 : 517

RECOMMENDATIONS (new), I.C.R.P. - I, S13 : 513

RECONSTRUCTION of accidents - VI, S21 : 311

RECOVERY - gastrointestinal system - haemopoietic system  
IV, S14 : 238

REGISTER (personal dose) computer - III, S10 : 034

REGULATION - III, S27 : 316

REGULATION (X-rays) - I, S08 : 030

REINDEER METABOLISM - II, P4c : 202

RELATIONS (public and industrial) - I, S29 : 086 - 425

RELEASES : see Index of sessions and sessions S02 and S20,  
see also WASTES

RELEASES, I.A.E.A. recommendations - II, S23 : 517

RELEASES (waste) - VI, S12 : 512

RELIABILITY - V, S03 : 382

REM-equivalent for chemical toxicity - I, S04 : 016 - 050

REM (thermal neutron) counter - V, P1 : 377

REPAIR mechanism - IV, S06 : 301

REPROCESSING plant : see PLANT

RESPONSE (energy) - V, P6 : 371 - 413

RESTORATION - IV, S24 : 237 - 433

RETENTION (mathematical model of) - IV, P7 - 223

RISK (non radioactive) - I, S01 : 227  
S08 : 094 - 469

RISK (acceptable) - I, S01 : 227 - 408 - 490

RISK/benefit - II, S19 : 472  
S22 : 055

RISK criteria - VI, S21 : 364

RISK (transport) - VI, S21 : 424

RUTHENIUM, sediment absorption - II, S02 : 221 - 388

SACCHARIDES - V, P6 : 176 - 414

SATURATED porous medium - II, S05 : 193

SCINTILLATION techniques - III, P2a : 432  
IV, S09 : 057  
V, P3a : 032  
P4a : 192 - 224 - 254 - 446  
.../

- SCINTILLATION (alpha particles) - III, S10 : 125 - 178
- SCINTILLATION (liquid) - V - P<sup>4</sup><sub>a</sub> : 173 - 442  
P<sup>4</sup><sub>b</sub> : 355
- SCINTILLATOR (spheres of) - V, P<sup>4</sup><sub>a</sub> : 173
- SEDIMENT absorption - II, S02 - 136 - 221
- SEDIMENT (ruthenium in) - II, S02 : 388
- S.H. group, molecular biology - IV, S06 : 301
- SHIELDING : see session P2b
- SHIELDING (accelerator) - V, P<sup>4</sup><sub>b</sub> : 401
- SHIELDING, design aspect - III, S27 : 293
- S.I. units - V, S03 : 157
- S.I. units, I.C.R.U. - V, S15 : 514
- SILICUM oxide - IV, S24 : 400
- SITOTOLOGY - II, S20 : 527
- SKIN, absorbed dose distribution - III, P2c : 461
- SKIN decontamination - III, S25 : 231
- SKIN dose - II, P5 : 250
- SKIN effects, low-level irradiation - III, S25 : 218
- SKYSHINE radiation - V, P2b : 216
- SOIL contamination - II, P<sup>4</sup><sub>c</sub> : 138 - 145
- SOLID state techniques - V, P<sup>4</sup><sub>a</sub> : 128
- SPARK counting - V, P6 : 129 - 159
- SPECTROMETER (bonner) - V, P<sup>4</sup><sub>b</sub> : 270 - 401
- SPECTROMETRY : see DOSIMETRY and, in particular, sessions P3a  
and P<sup>4</sup><sub>a</sub>
- SPHERICAL crystal - V, P<sup>4</sup><sub>a</sub> : 192
- STANDARDIZATION (dose quantity for) - V, S03 : 384
- STANDARD man - IV, S09 : 253
- STANDARDS (calibration) - V, P3a : 032 - 058 - 068 - 156 - 334

STANDARDS committee - I, S08 : 026 - 460

STANDARDS (radiation protection) - I, S07 : 130  
II, S22 : 419

STANDARDS (training) - I, S29 : 038

STATISTICAL procedure, cellular biology - IV, S06 : 010

STIMULATING effect - I, S01 : 428 - 490

STRONTIUM - II, P4c : 276  
S05 : 352  
IV, S21 : 036

STRONTIUM sulphate - V, P6 : 423

SURFACE contamination - II, S02 : 067  
V, P4a : 254

SURFACE water - V, P4a : 473

SURVEY instruments - V, S03 : 382

SYNDROM (gastrointestinal) - IV, S24 : 438

TAIWAN reactor - II, P3b : 186

TECHNETIUM 99 M - II, S19 : 245  
IV, S09 : 063

TELLURIUM metabolism - IV, S26 : 318

TEST (nuclear weapon) - II, P4c : 085 - 205

THERAPEUTIC (medical) - II, P5 : 150 - 244 - 248 - 263  
S19: 066 - 210 - 444  
IV, S17: 096 - 155

THERMOLUMINESCENT : see LUMINESCENT

THORON 220 and daughters - II, S22 : 207

THRESHOLD concentrations - I, S04 : 050 - 489

THRESHOLD dose - I, S01 : 095 - 428 - 451 - 490

THYROID - II, S19 : 066  
IV, S09 : 261

.../



T.N.O. - V, S03 : 356

TOMOGRAPHY (computerized axial) - II, P5 : 404

TOXICITY (alpha) - IV, S28 : 342

TOXICITY (chemical) - I, S04 : 016 - 050 - 251  
IV, S26 : 318

TOXICITY (plutonium with sodium) - IV, P7 : 062

TOXICITY (radionuclides) - IV, S28 : 084

TOXICOLOGY (animal experimental) - I, S04 : 489

TRAINING : see List of the general topics and session S29

TRAINING (education and) - II, P5 : 420

TRANSPLANTATION (intestinal) - IV, S24 : 438

TRANSPLUTONIUM elements - II, S05 : 295

TRANSURANI elements - V, P4c : 049

TRANSURANI elements (chelation) - III, S25 : 018

TRANSPORTABLE monitor - V, P4a : 174

TRANSPORT of UF6, risks - VI, S21 : 424

TREATMENT - IV, S24 : 438

TRITIUM, environmental contamination - II, S05 : 298 - 299 - 391

TRITIUM, internal contamination - III, P2a : 107

TRITIUM measurement - V, P4a : 153 - 173 - 174 - 254 - 442

TRITIUM production and leakage - III, S11 : 108 - 255  
S27 : 175

TUMORAL graft - IV, S28 : 342

TUMORS - IV, S24 : 229

U.F.6 (transport of) - VI, S21 : 424

ULTRASOUND - I, S07 : 130  
IV, S06 : 142

.../

ULTRAVIOLET radiation - I, S07 : 182 - 418 - 521

UNITS : see Index of sessions (DOSIMETRY) and V, S03 : 157

URANIUM - IV, S28 : 374

URANIUM mining : population exposure - II, S22 : 065  
V, P4a : 473

UTERUS dose - II, S19 : 444

VEGETABLES - II, S22 : 411

VENTILATION (aerosols) - III, S18 : 386

VENTILATION, iodine testing - II, S20 : 366

VETERINARY and agriculture : training - I, S29 : 004

VITAMINE C, mammalian cells - IV, S14 : 011

WASTES: see Index of sessions and session S12

WASTES, effluents monitoring - V, P4a : 128 - 153 - 173

WASTES management - VI, S12 : 512

WASTES disposal into the sea - II, S02 : 136

WASTES, effluents simulation studies - II, S02 : 392

WASTES (fogginess effect) - II, S02 : 184

WASTES, fossil-fuel nuclear power - I, S04 : 410

WASTES (gaseous effluent) - II, P3b : 100 - 421

WASTES, actinides irradiation - VI, S12 : 285

WASTES, phosphate industry - II, S22 : 419

WASTES (plutonium analysis from solid) - V, P1 : 393

WASTES, river contamination - II, S02 : 431

.../

WATER (household) - II, S22 : 397

WATER (mineral), animals - II, S22 : 455

WATER monitoring - V, P4a : 153 - 473

WELLS (bored) high activity - II, S22 : 397

WHOLE BODY monitor - III, P2a : 284  
V, P3a : 032 - 058

WORKERS exposure : see list of the general topics

WORKER-deaths statistics - I, S04 : 330

WOUND (contaminated) - VI, S21 : 358

X-RAYS - IV, S17 : 096  
V, S03 : 166  
P6 : 168  
VI, S21 : 311

X-RAYS (accelerators, bremsstrahlung) - VI, P2b : 216

X-RAYS (crystallography) : protection - III, S11 : 072

X-RAYS (gamma-rays), accident - III, S10 : 332

X-RAYS (high energy) - II, P5 : 150  
V, P4b : 270

X-RAYS regulations - I, S08 : 030

ZINC 65, animal - IV, P7 - 247

ZINC (D.T.P.A./) - III, S25 : 333

INSIGNIFICANT LEVELS OF DOSE : A PRACTICAL SUGGESTION  
FOR MAKING DECISIONS

G. A. M. Webb and A. S. McLean  
National Radiological Protection Board  
Harwell, Didcot, Oxon, United Kingdom

## 1. INTRODUCTION

All human activities entail some risk. Most uses of radiation or radio-activity will give rise to a distribution of doses and hence to a distribution of risks. At present it is assumed as a working hypothesis that all doses may carry some risk and that the incremental risk is directly proportional to the incremental dose. It is relevant however to ask whether there is a level of dose and risk which is insignificant from the point of view of the recipient. If this were so then the further question could be put whether these doses and risks which are insignificant from the viewpoint of the individual should be regarded as significant by society acting on behalf of that individual. In particular should these risks be regarded as so significant as to justify diverting resources to reduce them.

In this report the arguments for such insignificant levels of dose and risk are developed; a system is proposed for ignoring them in calculating collective doses for use in practical decision-making. The system involves defining a "cut-off" level of annual dose or dose commitment below which doses are not included in the calculation of collective dose from a "practice" in such a way that no-one is exposed to doses, which have been ignored, from too many practices. The term "practice" is used to mean an event or series of events which may lead to radiation exposure of people. The concept of a "cut-off" dose is not new and the authors would like to acknowledge helpful discussions with many people in developing the practical suggestions presented here.

## 2. RISK

Most people have an intuitive feeling of what is meant by risk and take decisions based on risk assessments very frequently. Some of these are concerned with financial risk, such as decisions to invest in a venture, back a horse etc., others are concerned with health and welfare risks such as decisions to smoke cigarettes or wear a car seat belt. A dictionary definition of risk is "the chance of bad nonsequences"; it is also convenient to consider a risk rate which may be defined as "the probability of unwanted consequences of an action or event within a specified period of time." This is similar to the definitions used by Starr (1) and Rows (2).

Since in the present context we are concerned with risks from radiation and these are manifest as effects on health we will restrict ourselves to considering risk in these terms. Health effects vary greatly in severity and are difficult to quantify simply; death is therefore the final effect concerning which statistics tend to be readily available and using which comparisons between radiation and other risks can be made. It is useful for comparison to express risk relative to time rather than to the causal event since different causes will be measured in different ways. A year is generally a convenient timescale for measuring the consequence of human endeavours so our basic definition of a continuous risk rate is: "The annual probability of death."

Individuals will often accept high risk rates in exchange for the benefits. These annual risks commonly range as high as  $10^{-3}$  for certain occupations or voluntary activities, including cigarette smoking. At lower levels of risk are most occupations which are not normally regarded as "hazardous" with an average annual risk ranging from  $10^{-4}$  to  $10^{-3}$  (3). The annual risk of death from natural causes (excluding accidents) for people in the prime of life is also about  $10^{-3}$  and at no period in life does it drop below  $10^{-4}$  (4). The risks from events over which people feel they have little control (involuntary risks) tend in general to be lower than the risks from voluntary activities.

The concept of a level of risk which is not taken into account by the individual when making decisions is the concept of a "negligible" level of risk. It is suggested that the lowest level of annual risk which people do take into account in decisions is probably in the region of  $10^{-4}$  to  $10^{-5}$  and that at some point below this the risks cease to be seriously considered and are therefore "negligible."

Quantitative levels for "negligible" risk have been suggested by several authors. Ash et al. reporting on a recent meeting (5) conclude, particularly on the basis of medical examples, that an annual risk of about  $10^{-5}$  is somewhere near the level below which concern ceases. Chicken (6) suggests that an annual risk of  $10^{-6}$  is the level below which no action to reduce a hazard is expected. Pockin (3) quotes estimates of activities giving rise to a risk of  $10^{-6}$  as smoking  $1\frac{1}{2}$  cigarettes, drinking  $\frac{1}{2}$  bottle of wine, travelling 50 miles by car or 250 miles by air, rock climbing for  $1\frac{1}{2}$  minutes, canoeing for 6 minutes, engaging in typical factory work for 1-2 weeks or simply being a male aged 60 for 20 minutes.

We propose that an annual level of risk of  $10^{-6}$  is one which is not taken into account by individuals in arriving at decisions as to their actions and which is therefore "negligible" i.e. it can be neglected.

### 3. FROM "RISK" TO "DOSE"

Since we are concerned with low levels of both dose and risk only late effects of radiation need be considered. These effects are reviewed in great detail from time to time but for the purposes of this paper a very broad approach has been adopted.

The assessment of late somatic effects is based on a linear, no-threshold model in which the probability of cancer death is considered to be directly proportional to the total dose. Bearing in mind that linear extrapolation from effects at high doses and dose rates might over-estimate possible risks, at least for low LET radiation, an overall risk coefficient for death due to induction of all cancers of  $10^{-4}$  per man rad seems a reasonable order-of-magnitude estimate of the uppermost level. In view of the latent period between the receipt of the dose and the appearance of cancers in the irradiated population a direct comparison of the risk of death from cancer induced by radiation with the risk of death from natural hazards and most other causes mentioned earlier will over-emphasize the relative hazard from radiation.

In addition to the somatic risk from radiation, hereditary defects may occur in the descendants of the irradiated population and will be superimposed on the normal incidence of serious hereditary defects. For our broad approach we have assumed that if the risks of direct somatic effects are very low, then the risks of serious genetic effects will be even lower and will not change our order-of-magnitude risk estimate.

On this basis an annual risk of death to the individual from cancer of  $10^{-6}$  will correspond to an annual dose of the order of 10 mrad or more. In addition to the individual risk of death this dose will carry a lower risk of future serious hereditary defects.

In view of the many assumptions which are likely to lead to over-estimates of the risk from radiation and the delayed effects of that radiation an annual dose or dose commitment of 10 mrad may be regarded as even more likely to be insignificant from the viewpoint of the individual. Because of the way it has been derived this proposed value of 10 mrad applies strictly to whole body irradiation. It would be correct when considering individual organs to adopt different, higher values corresponding to the same risk level. In view of the purpose for which an insignificant dose has been defined, however, such refinement is not considered necessary and the insignificant annual dose or dose commitment of 10 mrad may be taken to apply to the whole body or to specific organs.

#### 4. A COMPARISON OF THE PROPOSED "INSIGNIFICANT" DOSE WITH ACCEPTED VARIATIONS IN INDIVIDUAL DOSES

It is legitimate to compare the "insignificant" dose derived above with variations in individual doses which are themselves regarded as of no consequence or simply ignored. Natural background radiation is the most useful comparison but certain aspects of medical irradiation are also suitable.

Most of the dose to an individual in general is due to natural background radiation of both cosmic and terrestrial origin. There is, and always has been, a variation in natural background radiation dose between different localities in the United Kingdom and throughout the world. The known variation in local, naturally occurring radiation to which people in the UK are exposed in the course of their ordinary every-day existence is such that the resulting annual doses for different individuals may be anywhere in the range 50 - 200 mrad. This almost certainly under-estimates the true variation, but it is at least ten times the dose which we propose should be regarded as "insignificant."

Although variations in the cosmic ray component of natural background are small at ground level especially within the UK, the dose rate increases rapidly with altitude. At the cruising height of conventional jet aircraft the cosmic ray dose is about  $0.4 \text{ mrad h}^{-1}$  so a dose of 10 mrad would be received in roughly 25 hours flying.

A further indicator may be found in the recent guidelines on irradiation of Human Subjects for Medical Research (7). Experiments in the lowest category involve total body doses of the order of 10 mrad and are said to give rise to no particular radiation protection or radio-biological problems. The risk resulting from experiments in this category is described as negligible, using similar arguments to those developed here.

#### 5. USE OF THE CONCEPT OF "INSIGNIFICANT DOSES" TO ASSIST IN DECISION MAKING

The present guidelines on which decisions should be based are those formulated by ICRP in Publication 9 (8) and elaborated in Publication 22 (9).

##### 5.1 Individual dose limits

The existence of a limit does not of itself give any indication of how far below the limit (if at all) the maximum or average doses should be

maintained. More significantly it does not assist in the consideration of how much effort should be expended to maintain doses at any lower level. In our view the main usefulness of the dose limits and criteria derived directly from them such as Derived Working Limits (DWL) is to provide a means of assessing the significance of measured doses or other parameters. This is particularly true of DWLs since in their most useful form they are specific to a particular nuclear installation or environmental parameter.

## 5.2 Collective dose and collective dose commitment

Because of the limitations noted above ICRP suggested the use of the quantity "Collective dose" as a tool for use in cost-benefit analysis.

It is generally insufficiently realized that there are many assumptions underlying the definition and use of the quantity collective dose. The most fundamental is the assumption of direct proportionality between dose and effect at all levels of dose. Other assumptions are that there is no threshold below which doses are inconsequential, that dose rate is unimportant and that damage repair does not occur. Given a full realization of these assumptions the quantity can be useful in certain ways.

(1) If the dose rates and dose distributions from two practices are similar the collective doses can be used to compare the relative radiation detriments from the practices.

(2) If all the above assumptions can be granted and a figure agreed for the monetary cost of collective dose then this can be used to assess the cost-effectiveness of methods for reducing doses.

An extension of the idea of collective dose is that of collective dose commitment, in which the future dose rate is integrated over time.

## 5.3 Imposition of limits on the integrals

Despite the underlying assumptions it is normally accepted that the lower and upper limits for the integration of collective dose are zero and infinity respectively. It is sometimes pointed out that there is a practical upper limit in the region of the dose limit for very many situations but no such qualification is normally attached to the lower limit despite the suggestions by ICRP (9) that:

"The use of the concept of population dose in the process of decision making should, therefore, be supplemented by consideration of the dose to individuals. At low levels of individual dose, e.g. those small by comparison with variations in local natural background, the risk to the individual is so small that his health and welfare will not be significantly changed by the presence or absence of the radiation dose." and

"In practice, however, at levels of individual dose that are small fractions of the relevant dose limit, there will be no need to pursue the summation beyond the point where it becomes clear that the further contribution to the sum will not change the estimate of population dose by more than a factor of 2 or 3."

We therefore propose to formalize the calculation of collective dose for the purpose of practical decision-making by means of a numerical lower limit to the integrals both in space and time. This lower limit, if properly chosen, will serve several useful functions:

(1) It will codify an existing situation in which most collective doses are calculated with some arbitrary limit which may be defined by the distance from the source, the population of a country, the lower limit of detectability of the measuring equipment used or the year 2000.

(2) It will prevent effort being expended on the measurement, estimation or calculation of doses which the individual would regard as of no consequence and help to focus attention on those doses which may matter.

(3) It will make the estimation of harm from radiation more compatible with estimates of harm from other causes. This should make comparisons less heavily weighted against options involving radioactivity and also promote the adoption of better standards for other causes of detriment if those adopted for radiation seem reasonable and practicable. This would be in line with the advice given by ICRP (10) that:

"The more cautious such a procedure (estimates of risks from radiation) is, the more important it becomes to recognise that it may lead to an over estimate of the radiation risks, which in turn could result in the choice of more hazardous alternatives to practices involving radiation exposure."

It is worth noting for example that the numerical value of the analogue of the "collective dose commitment" with a lower limit of zero is infinity for any non-degradable chemical pollutant.

For these reasons we propose that the definition of collective dose from a given "practice" for the purposes of making decisions should be:

$$\int_{D_0}^{\infty} D N(D) dD$$

where  $D_0$  is the out-off below which individual doses are not included in the integration.

Similarly the definition of collective dose commitment should be

$$\int_0^{T_0} \int_{D_0}^{\infty} \dot{D} N(\dot{D}) d\dot{D} dT$$

where  $T_0$  is the time at which the maximum annual individual dose of the distribution falls below  $D_0$ .

## 6. DEFINITION OF A "PRACTICE" AND OF A "CUT-OFF DOSE"

In order to arrive at a numerical value for  $D_0$  we will need to define a "practice" sufficiently broadly that doses which have not been included in the integration do not, for any individual, exceed in total the level of dose regarded by the individual as insignificant. Thus the definition of a practice and the choice of a dose below which individual doses are not included in the integration are interrelated. It is clear that however a practice is defined a person will be likely to be exposed to a number of practices so the cut-off dose adopted will be some small fraction of the dose regarded as insignificant by the individual.



Taking into account the various sources of irradiation of the public and their associated level of dose we propose that a "practice" and a "cut-off dose" should be defined for the purpose of decision making such that an average individual will be highly unlikely to receive in a year enough doses from practices which have been ignored on his behalf that they would in total exceed 10 mrad.

#### 6.1 Formal Definitions

We propose that this could be achieved with the following framework of definitions on the basis that no individual is likely to receive doses approaching the cut-off level from more than, at most, a few tens of practices.

Cut-off Dose, D<sub>c</sub>: The level of annual individual dose or dose commitment incurred during a year below which doses are not included in the integration when calculating collective doses from a practice for the purpose of decision making. This annual dose or dose commitment is defined as 0.7 mrad. As was noted in section 3 the same numerical value is taken to apply for whole body or organ doses.

Practice: Category A. For devices or procedures which irradiate individuals (consumer products, miscellaneous sources, medical uses of radiation, occupational exposures) a practice is defined as :

One year of utilization of the device or procedure.

Practice: Category B. For procedures giving rise to environmental contamination and doses to numbers of people (waste disposals, atmospheric nuclear weapon tests) a further distinction is necessary on the basis of radionuclide half-life.

B1 - For radionuclides with half-lives less than 1 year a practice is defined as:

One year of release of a radionuclide from a site or a number of related sites.

B2 For radionuclides with half-lives greater than 1 year, since these will accumulate in the environment and need to be considered over a longer time span, taken as thirty years, a practice is defined as :-

Thirty years of release of a radionuclide from a site or a number of related sites.

In the above definitions the term "related sites" means those which can be expected to cause irradiation of the same people.

### 7. INTERPRETATION OF THE DEFINITIONS

In principle the definitions under 6.1 should cover all situations. In reality however for many situations they are not relevant. In this section the broad methods of application of the definitions are examined.

#### 7.1 Category A Practices

Medical uses of radiation - The definition means that each type of examination which is normally carried out no more often than once a year on each patient will be counted as a "practice." For those examinations or

treatments which require several exposures to radiation than the full course will be the "practice."

Consumer Products - The implication of the proposal is that individual annual doses or dose commitments less than 0.1 mrad from any product need not be considered in assessing the product. This will mean that products which give rise to doses less than the cut off will not need to be carefully assessed and justified against these doses but can be regarded as of no radiological consequence.

Occupational exposure - the use of this definition would have very little effect on the assessment of the importance of occupational doses.

## 7.2 Category B1 Practices

The effect of this definition would be to codify the existing situation in which short-lived radionuclides are ignored unless they are discharged in sufficient quantities and in such circumstances as to give rise to doses to members of a critical group which are a significant percentage of the dose limit. The formal definition would quantify this by stating that these radionuclides could be ignored unless there was an individual annual dose from a radionuclide exceeding 0.3 mrad (0.02% of the current whole body dose limit). If there were doses above this, it might be desirable to assess the costs of reducing the discharges; otherwise the exercise need not be carried out.

## 7.3 Category B2 Practices

Depending on the particular radionuclides involved and the circumstances of the release, practices in this category may be considered to affect local areas, regions or even the whole world.

If a radionuclide were released in circumstances such that doses were only received by people living around the site then the release could be considered as an isolated practice. In the case of releases from a number of sites into a common environment, such as a river or sea, then the releases from all the sites would need to be considered together. In some very special circumstances, such as releases of noble gases to atmosphere, then the releases from all the sites in a region must be considered together. In the latter case, since the objective is decision-making, it is not useful to extend the region outside of the control area so this is defined as a country or group of countries.

Some of these radionuclides will have very long half-lives but it is not possible to allow for their indefinite build-up in the environment, partly because of uncertainties attending the duration of their products. It seems therefore that the rational way to proceed is to make decisions for the timescales for which equipment and plant will last (about three decades), and then for subsequent future decisions to take into account the persistent effects of past decisions. If this seems to be pre-empting the freedom of action of future decision-makers we would point out that such pre-emption is normal. An outstanding example is our deliberate use of limited energy resources.

## 8. CONCLUSION

We have proposed a system for assessing the component of the collective dose from different practices which is appropriate for use in decision-making based on the concept that there exists a level of annual dose which is insignificant to the individual. On the basis of an analysis of risks

from other causes and the normal variations in doses to which people attach no importance we propose that this level of annual dose or dose commitment incurred during a year is 10 mrad.

We have then defined a practice and a cut-off dose of 0.1 mrad to allow for many practices in such a way that individuals will not be exposed to a sufficient number of practices that the total of the annual doses, each individually below the cut-off, could exceed 10 mrad.

The use of this system to calculate collective doses will codify and make consistent existing decision-making criteria with relation to widely disparate practices. It will have the effect of directing attention and effort away from massive analyses of trivial doses back to those higher doses which may indeed be of significance and which if possible should be reduced.

One effect of using the system will be that the collective dose from certain practices, which give rise to a dose distribution which includes no annual doses in excess of 0.1 mrad, can be ignored completely for the purposes of decision making. Another effect will be that when the collective dose from a given practice includes annual doses above 0.1 mrad the magnitude of the calculated collective dose increases very rapidly with small changes in the practice. This introduces an effective non-linearity into the relationship between the calculated detriment and the size of the releases from the practice and penalises those practices giving rise to annual doses in excess of 0.1 mrad in comparison with practices giving rise to annual doses of the order of or less than this value.

#### REFERENCES

1. STARR, C., "Social Benefit versus Technological Risk." *Science* 165, 1232-1238. (September 1969)
2. ROWE, W.D., "An 'Anatomy' of Risk." US Environmental Protection Agency, Washington D.C. (March 1975)
3. POCHIN, E.E., "The Acceptance of Risk." *Br. Med. Bull.* 31 3, 184-190 (1975)
4. REGISTRAR GENERAL. "Registrar General's statistical review of England and Wales for the year 1970." HMSO, London. (1972)
5. ASH, P. J. N., BAVERSTOCK, K. F. and VENNART, J. "Risks of everyday life." *Community Health*, 8, 29 - 38, (1976)
6. CHICKEN, J. C. "Hazards Control Policy in Britain." Pergamon Press, (1975).
7. British Institute of Radiology "Irradiation of Human Subjects for Medical Research." *BLR Bulletin* 1 No. 2 L - 6 (1975)
8. ICRP. Recommendations of the International Commission on Radiological Protection. Publication 9. Pergamon Press. 1966
9. ICRP. Implications of Commission Recommendations that Doses be kept as low as Readily Achievable. Publication 22. Pergamon Press (1973)
10. ICRP. Commission Statement on "Use of Risk Estimates." *Health Physics* 21, 615 - 616, (1971)

THE LINEAR HYPOTHESIS OF RADIATION DAMAGE APPEARS TO BE  
NON-CONSERVATIVE IN MANY CASES

Karl Z. Morgan  
School of Nuclear Engineering  
Georgia Institute of Technology  
Atlanta, Georgia 30332, USA

The purpose of this paper is to express a word of caution to those members of the International Radiation Protection Association (IRPA) and to members of the International Commission on Radiological Protection who seem to believe our present levels of maximum permissible dose (MPD) for occupational workers and dose limits (DL) for members of the public are unnecessarily low and should be increased. At the same time, I would caution persons in the United States who are advocating that present levels should be reduced by an order of magnitude. Likewise, I wish to discourage some members of IRPA from repeating their claim that the linear hypothesis, upon which we base our present radiation protection standards, is overly conservative.

I believe present values of MPD are satisfactory, but only because in industry and in the vast majority of nuclear energy programs these values are considered as upper limits so that on the average exposure to radiation of workers does not exceed 10% of MPD. This practice has developed as a result of the principle of ALARA (exposures As Low As Reasonably Achievable). Were the day to come when occupational exposures are averaging 50 to 80% of the MPD, I would be first to urge a reduction in present MPD. In this connection, I deplore the fact that some nuclear power plants and fuel reprocessing plants in the United States have ignored the principle of ALARA, have adopted the practice of "burning out" employees by using "expendable" temporary employees, and have exceeded 1000 man-rem/y at some of the power plants. It is unfortunate, also, that for the most part the medical profession ignores the principles of ALARA for patient exposures. I do not believe, however, that the solution to these problems is to lower MPD and DL by an order of magnitude, for then many health physicists would feel obligated to reduce exposures to 1% or less of our present values; this could deprive us some great benefits that can be expected from proper use of ionizing radiation. For example, I believe present average occupational exposure of 5 to 10% MPD = 250 to 500 urem/y to total body does not present an unreasonable or unusual occupational risk. We might expect this risk to be of the order of  $500 \times 10^{-3} \times 10^{-4}$  c/rem  $\times 40$  y = 6 chances of cancer from occupational exposure per 1000 radiation workers. The long range genetic risk would be about the same magnitude as somatic risks, and I consider this acceptable in comparison with risks in safe occupations. However, I would consider a 6% cancer plus a 6% genetic risk too high. I feel the same about not changing population DL so long as present practice limits this on the average to less than 10%.

With the demise of the threshold hypothesis, the linear hypothesis has gained acceptance as the basis for setting radiation protection standards and this has led some health physicists to decry its use and make incorrect claims: 1) The linear hypothesis holds only in the high dose range, 2) There are no human exposure data indicating radiation damage due to low doses (ionizing or non-ionizing), and 3) The linear hypothesis is always overly conservative in the low dose range.

Regarding claim number 1, just the opposite is true. In the high dose range the linear hypothesis always breaks down because one cannot cause deaths in over 100% of exposed population and a maximum effect is reached at some intermediate dose because at higher doses the animals do not survive long enough to die of effects under study. It is true that for low I.M.T radiation

the linear hypothesis is often conservative for low doses administered to animals because time is allowed for cell repair and cell replacement. However, studies of production of leukemia as a result of in utero x-ray exposure<sup>1,2</sup>, and exposure to young people<sup>3,4,5</sup>, as well as some studies on old animals, suggest that very young and very old members of a population are radiosensitive and the linear hypothesis, as applied to them, is non-conservative even for low LET radiation. Many evaluations of<sup>6,7,8,9,10,11</sup> cancer production from high LET radiation of humans as a consequence of body burdens of radium indicate that if there is departure from the linear hypothesis in the low dose range it is in the direction of more cancers produced per rad at low doses than at high doses and that protraction<sup>12</sup> of time over which dose from <sup>224</sup>Ra is delivered to patients increases rather than decreases the risk of cancer.

Regarding claim number 2, there are many publications reporting harmful effects of low exposures to both ionizing<sup>1,2,3,4</sup> and non-ionizing<sup>13,14</sup> radiations, so I can only conclude those who repeatedly claim such data do not exist must completely discount the validity of such studies. I do not agree that findings of these studies can be ignored and believe the validity of some of the findings is sufficiently substantiated that we must take seriously enforcement of the principle of ALARA.

It is easy to understand why there are adherents to claim 3, and why many disciples of the old threshold hypothesis are reluctant to abandon belief that if one does not exceed a threshold dose there is no risk of radiation damage, or if the dose is kept below a threshold value, the rate of repair can keep pace with the rate of damage produced. It is true in many cases, and especially for low LET radiation, the rate of repair may keep up with the rate of damage. In some cases also the average incubation period for certain malignancies may be longer than expected remaining life. However, we should not take too much comfort in such observations because each person differs in response to radiation such that the only safe assumption is that no dose can be so low that the probability of radiation damage is zero.

Generally accepted theories of damage lead to the conclusion that a given type of radiation damage from a given type of exposure is simply a matter of chance. By this we mean that of the millions of photons and alpha particles that loose energy in an organ of our body each day; there is always the remote chance that one of these will damage a cell in such a way that it survives, but only to reproduce itself in its perturbed form and that in time there develops a clone of perturbed cells which is identified as a malignancy. The fact that there is no "safe" level of radiation exposure is not a unique type of risk--we all know, for example, there is never a trip in a Paris taxi that is "safe."

Now that we have discarded the threshold hypothesis, let us summarize reasons why in some cases use of the linear hypothesis to estimate risk at low doses is not a conservative assumption as follows:

1. Overkill at high doses. Most estimates of risk from radiation exposure are based on linear extrapolation of effects at high doses down to zero dose. Often with such extrapolation insufficient account is taken of overkill and that in no case can more than 100% of the animals be killed by radiation. Sometimes one simply determines the best least-squares line which will pass through the (0,0) point. Some points used in determining the slope of this line may be on the bend of the curve where the animals are injured by large doses of radiation such that they do not survive long enough to die of the effect under study.
2. Short follow-up period of human studies. Most studies<sup>15</sup> of effects

of ionizing radiation on man extend over only a small fraction of his life span. If one determines the slope of curve of thyroid carcinoma risk vs x-ray dose and the followup period is only 7 years; studies of population until all have died would increase the slope of curve and risk estimate.

3. Fractional life span animal studies. Sometimes comparisons are made between fetal damage during first trimester of a mouse and damage we might expect during first trimester of a woman, or a comparison is made over life of animals having a life span of 20 years with expected effects over life span of man. Since in many cases damage from radiation exposure may relate more closely to what happens in a given number of years following exposure rather than what happens over a certain fraction of the animals' life span, such extrapolations to man can only lead to underestimates of risk.
4. Radiosensitivity differs among animal species. Many studies have emphasized the risk of extrapolating data on effects of radiation exposure from one animal to another or to man. Differences in metabolism, turnover rate, GI tract uptake, skin perspiration, blood circulation, mitotic index, etc., can have a marked effect on animal response to a given dose of ionizing or non-ionizing radiation. An examination of data leads me to conclude that more often than not this kind of extrapolation to man results in an underestimation of risks.
5. Heterogeneity of human population. The vast majority of studies of effects of radiation exposure are carried out with inbred animals. Radiation ecology programs must be extended to animals in the wild if we are to simulate effects we expect from low doses to human populations. Studies of Bross<sup>16</sup> have indicated that risk of leukemia as a consequence of in utero x-ray exposure increases by 5000% if the child had diseases such as asthma, hives, eczema, allergy, pneumonia, dysentery or rheumatic fever compared with the child without this exposure and history of such disease. In assessing population risk of low levels of exposure we need to know dose response for young and old, male and female, sick and well, fat and slim, the person of average eating habits and the one with peculiar eating habits, etc. When we have such data, our estimates of risk from low level exposure will increase.
6. Cell sterilization. It is well established that as old age is approached, the percent of abnormal cells in the body increases; for example, the percent of chromosomal aberrated cells increases with age of an animal. It is commonly believed that some types of malignancies develop as a result of a series of changes that take place in the 46 chromosomes that comprise the nucleus of a normal somatic cell in man. Sometimes certain of these changes may be the result of genetic mutation conveyed from one's parents. Thus, we have a scattering of cells and clones of cells which have one or more abnormalities, and may present a much larger cross-section for the production of a malignancy than a normal cell. It may be that the etiology of cancer is similar to throwing of a series of switches such that cancer cannot develop unless all switches are thrown. Children born in a family with one of "switches" thrown genetically have a higher cancer risk than average children and persons who have been exposed to higher levels of carcinogens have more high cross-section cells that are likely targets for the origin of a malignancy. When studies are conducted on animals exposed to high doses of radiation, cell sterilization may take place such that many cells that are likely targets for development of a malignancy are destroyed. Thus, such data points at high exposure levels would tend to reduce the slope of the curve that is extrapolated to zero dose

and may result in an underestimate of risk at low levels of exposure.

#### REFERENCES

- (1) STEWART, Alice, KNEALE, G.W., "Radiation Dose Effects in Relation to Obstetric X-Rays and Childhood Cancers," *Lancet*, 1185 (June 6, 1970)
- (2) BROSS, I.D.J., NACHIMUTHU, N., "Leukemia from Low Level Radiation," *New England Journal of Medicine* 287, 107 (July 20, 1972)
- (3) MODAN, B., BALDATZ, D., STEINITZ, R. LEVIN, S.G., "Radiation-Induced Head and Neck Tumors," *Lancet*, 277 (February 23, 1974)
- (4) SILVERMAN, Charlotte, HOFFMAN, D.A., "Thyroid Tumor Risk from Radiation During Childhood," *Preventive Medicine* 4, 100 (1975)
- (5) BOICE, J.D., Jr., MONSON, R.R., "Breast Cancer Following Repeated Fluoroscopic Examinations of the Chest," Bureau of Radiological Health, PHS, HEW, Rockville, MD 20857, (December 1976)
- (6) GOFMAN, J.W., TAMPLIN, A.R., "The Question of Safe Radiation Thresholds for Alpha Emitting Bone Seekers in Man," *Health Physics* 21, 47, (1971)
- (7) BAUM, J.W., "Population Heterogeneity Hypothesis on Radiation Induced Cancer," *Health Physics* 25, 97 (August 1973)
- (8) BROWN, J.M., "Linearity vs. Non-Linearity of Dose Response for Radiation Carcinogenesis," *Health Physics* 31, 231 (September 1976)
- (9) LANDAN, E., "Health Effects of Low-Dose Radiation: Problems of Assessment," *Intern. Journal Environmental Studies* 6, 51 (1974)
- (10) HOLFORD, R.M., "The Relation Between Juvenile Cancer and Obstetric Radiology," *Health Physics* 28, 153 (February 1975)
- (11) CRAIG, A.G., "Alternatives to the Linear Risk Hypothesis," *Health Physics* 31, 81 (July 1976)
- (12) MAYS, C.W., SPIESS, H., GERSPACH, "Skeletal Effects Following  $^{224}\text{Ra}$  Injections into Humans," Symposium on Biological Effects of Injected  $^{224}\text{Ra}$  and Thorotrast, Alta, Utah, (July 21-23, 1974)
- (13) WORLD HEALTH ORGANIZATION. et.al., "Biologic Effects and Health Hazards of Microwave Radiation," Proceedings of an International Symposium- Warsaw 15-18 October 1973, Warsaw Poland: Polish Medical Publishers, (1974)
- (14) CARPENTER, R.L., "An Experimental Study of the Biological Effects of Microwave in Relation to the Eye," (RADC-IDR-62-131) Griffiss Air Force Base, New York; Rome Air Development Center; (February 1962)
- (15) The Effects on Populations of Exposure to Low Levels of Ionizing Radiation, a report of the Advisory Committee on the Biological Effects of Ionizing Radiations (BEIR-Report), National Academy of Science, NRC page 89, (November 1972)
- (16) BROSS, I.D.J., "Proceedings of the Congressional Conference on Low Level Radiation," Senate Office Building, Washington, D.C., (May 4, 1976)

## CENTRALES NUCLEAIRES ET PREVENTION SANITAIRE

M. Delpla

E.D.F. 1, Avenue du Général de Gaulle 92141 Clamart

## 1. INTRODUCTION

Pire à supporter que sa mort, c'est, peut-être, la vie d'un enfant en rémission de leucémie : condamné ; c'est peut-être, aussi, qu'il soit grossièrement différent des autres : "handicapé". Selon une information largement diffusée, ces pires maux, et bien d'autres, pourraient être causés par les centrales nucléaires dans leur environnement. Qu'une telle information ait un impact terrifiant ne saurait surprendre. En raison de la gravité de tels effets, des hygiénistes ont voulu prévoir quels pourraient être — dans les pires hypothèses — les dommages sanitaires provoqués par de faibles doses sur une population nombreuse. Se voulant prudents, ils ont admis, pour chaque effet délétère, que le risque serait proportionnel à la dose cumulée ; il en résulte que le dommage serait proportionnel à la dose-population. Un tel dommage, inquiétant, n'a rien de réel. Nous allons le voir sur quelques exemples, limités, faute de place, à la leucémie et aux cancers thyroïdiens.

## 2. RESULTATS DE CALCULS PREVISIONNELS

Dans l'exposé des résultats de l'enquête de l'A.E.C. (1971-1973) dans l'environnement de centrales nucléaires et chez les constructeurs, les auteurs donnent des coefficients de conversion d'une dose collective en dommages prévisibles pour la population américaine ; soit 26 pour la leucémie, 110 pour le cancer thyroïdien, et 75 pour les autres cancers, par million de personnes-rem.

Considérons une population de 200 millions de personnes, dont 1 % travaillent habituellement avec des sources de rayonnements ionisants, et dont 10 % peuvent être considérées comme incluses dans le "groupe critique" d'une installation industrielle nucléaire ; si ces personnes sont exposées depuis très longtemps aux limites de dose des normes de la CIRP (1966), les coefficients précédents permettent de calculer le dommage prévisionnel pour ce qui concerne le cancer ; les résultats figurent dans le tableau I, ils donnent les nombres de cancers qui seraient ajoutés annuellement. De tels nombres inquiètent.

TABLEAU I

Dommage prévisionnel pour l'irradiation au maximum des normes

Catégorie	Dose (rem/an)	Leucémie	Cancer thyroïde	Autres cancers
Travailleurs	5	170	650	820
Gr. critiques	0,5	260	1 100	750
Ensemble population	5/30	870	3 600	2 500

## 3. OBSERVATIONS RELATIVES A LA LEUCEMIE

Deux publications sont fondamentales : celle de Court-Brown et Doll (1957) sur un groupe de rhumatisants après radiothérapie du rachis, et celle de Jablon et Kato (1971) qui rapporte les observations faites de 1950 à 1970 sur les survivants d'Hiroshima et de Nagasaki (nous ne retiendrons que le groupe de Nagasaki parce qu'il a reçu relativement peu de neutrons). Pour comparer les



résultats de ces travaux différents nous avons, pour chaque classe de personnes, évalué la dose moyenne dans l'ensemble de la moelle osseuse (les cinq douzièmes de la dose rachidienne des rhumatisants ; les deux tiers de la dose dans l'air, à Nagasaki). Nous n'avons retenu que les classes où cette dose ne dépasse pas 150 rems. Les observations cliniques conduisent à des résultats semblables (risque "ajouté" négatif à 50 rems) et s'éloignent sensiblement de l'hypothèse linéaire proposée par Court-Brown et Doll (1957) eux-mêmes, comme hypothèse de travail.

**TABLEAU II**  
Risque annuel de mort par leucémie ajouté par l'irradiation\*  
valeurs déduites, soit des observations, soit de l'hypothèse linéaire

Dose moelle (rems)					
radiothérapie .....			50		
Nagasaki .....	3	15	50	100	150
Risque ajouté (/10 <sup>6</sup> personnes-ans)					
radiothérapie .....			- 50		+ 80
Nagasaki .....	0	-20	- 50	+ 80	
hypothèse linéaire * *		+ 15	- 50	+ 100	+ 150
		+ 22,5	- 75	+ 150	+ 225
* Pour chaque classe, différence entre la valeur observée et le risque spontané, trouvé égal à 50/10 <sup>6</sup> personnes-ans pour chacun des groupes.					
* * Suivant que le risque serait de 1 ou 1,5/10 <sup>6</sup> personnes-ans-rems.					

#### 4. TUMEURS THYROÏDIENNES APRES IRRADIATION DANS L'ENFANCE

Selon un rapport de l'Académie des sciences américaine (1971), le risque de cancer thyroïdien serait augmenté de 1,6 à 9,3 par million de personnes-ans-rems ; mais de telles valeurs reposent sur l'observation de personnes qui avaient toutes été des enfants malades. Or on peut trouver aussi des personnes dont le corps thyroïde a été irradié dans l'enfance comme par hasard ; elles paraissent mieux susceptibles que les autres de représenter la population générale. Nous rapporterons quatre exemples. Conti et coll. (1960) n'ont trouvé aucun cancer thyroïdien sur 1 564 personnes d'une vingtaine d'années ; elles avaient reçu — préventivement, systématiquement — 150 rems sur le thymus peu après leur naissance. La dernière publication de Conard sur les insulaires contaminés accidentellement dans le Pacifique date de 1975. Pour ceux qui n'avaient pas 10 ans en 1954, Conard a relevé : à Rongelap, 17 lésions thyroïdiennes sur 19 personnes ; à Utirik, sur 53 personnes, aucune lésion, même pas de tumeur bénigne. A Rongelap, pour que leur contamination à un an ait provoqué l'atrophie de leur corps thyroïde, deux enfants avaient sans doute reçu dans cet organe des dizaines de milliers de rems ; sur cet îlot, tous ont reçu des doses considérables. A Utirik, au contraire, elles auraient atteint seulement une cinquantaine de rems. Hallison et coll. (1974), ont examiné systématiquement 1 378 enfants âgés d'une quinzaine d'années ; ils avaient, durant des années, consommé du lait contaminé par les retombées des explosions nucléaires expérimentales du Nevada, et, de ce fait, dû cumuler une centaine de rems dans leur corps thyroïde ; avec 18 tumeurs bénignes, ce groupe ne présentait aucune différence avec deux groupes témoins (on a trouvé un cancer dans chacun de ceux-ci, et aucun dans l'autre). Modan et coll. (1974) ont trouvé douze cancers thyroïdiens sur 10 902 enfants immigrants dont la teigne, à leur arrivée en Israël, avant 1960, avait fait l'objet de

radiothérapie ; le risque correspondant, de 1 100 par million de personnes, excède de façon statistiquement significative la valeur de 200 trouvée dans chacun des deux groupes témoins. Selon des mesures sur fantôme, le corps thyroïde n'aurait cependant reçu que 6,5 rems. Pour interpréter leur observation, les auteurs proposent trois explications : l'extrême sensibilité du corps thyroïde de l'enfant à l'irradiation (généralement admise, une telle sensibilité ne se retrouve dans aucune des trois observations précédentes) ; l'augmentation du risque de cancérisation de cette glande par l'irradiation concomitante de l'hypophyse ; la négligence, durant la radiothérapie (précisons en effet qu'en cas de collimation insuffisante du faisceau de rayons X sur les champs latéraux, ou de son mauvais centrage, le corps thyroïde a pu recevoir de l'ordre de 3 000 rems, et même bien davantage, au cours du traitement ; notons aussi que certains enfants, dont la proportion n'est pas précisée, ont subi ce traitement deux fois, et même trois, pour récurrence).

## 5. DISCUSSION

L'hypothèse d'une relation de proportionnalité entre le risque et la dose est généralement admise, et considérée comme prudente. Or son application prévisionnelle à des populations nombreuses de personnes supposées irradiées durant longtemps à des doses aussi faibles que les limites des normes de la CIRP inquiète, non seulement pour ce qui concerne les effets somatiques (voir ci-dessus, § 2), mais aussi en matière d'effets génétiques. Au contraire, pour des doses qui ne sont, ni très faibles, ni très élevées, des observations cliniques et des expérimentations ont montré, du moins pour certains dommages, des risques ajoutés négatifs. A partir de tels risques les calculs feraient prévoir un allègement de la charge sanitaire. Pour comprendre cette contradiction, nous opposerons deux interprétations des modes d'action des rayonnements ionisants, l'une statique, l'autre, dynamique. Selon la première, bien traduite par la théorie des cibles, l'hypothèse de proportionnalité du risque à la dose, lorsque celle-ci est faible, devient une vérité mathématique. Elle a été confirmée par l'interprétation statistique de dommages obtenus expérimentalement par l'irradiation de molécules, ou de cellules, jusqu'à des valeurs très faibles de la dose. Pour les organismes complexes, elle concorde avec l'interprétation stochastique de risques d'effets somatiques tardifs, ou d'effets génétiques à la F<sub>1</sub>, mais seulement après des doses élevées (des centaines de rems en peu de temps). Considérons maintenant un tissu qui contient des cellules souches (c'est à dire un tissu vulnérable) et qui vient de recevoir en un temps très court une dose de rayonnements ionisants qui n'est, ni très faible, ni très élevée (disons quelques rems, ou quelques dizaines de rems) ; dans une première phase ses cellules restaurent leurs lésions moléculaires, ou meurent ; par la suite, la fréquence des mitoses augmente afin de pourvoir au remplacement des cellules mortes, ou demeurées par trop défectueuses. Entités dynamiques susceptibles de réagir dans chacune de leurs parties, ou en bloc, l'être vivant, ses cellules, son espèce, constituent des ensembles coordonnés et génétiquement asservis à la conservation de cette dernière. Chacune à son niveau, suivant ses possibilités, restaure sans cesse les atteintes provoquées par des agents issus du milieu dans lequel elle vit et qui lui est indispensable. Toute cause d'agression ajoutée dans le milieu (en particulier des sources de rayonnements ionisants) en augmentant les besoins, stimule les processus de restauration ; on peut penser que, du moins dans certaines conditions, la stimulation dépassant les besoins créés par l'agression ajoutée, contribue à améliorer la restauration d'autres lésions, voire même

à stimuler d'autres processus biologiques. D'où la possibilité d'addition de risques négatifs. De tels phénomènes, inconcevables dans une interprétation statique des effets d'une irradiation, demeurent généralement inaperçus des chercheurs ; dans le cas contraire, ils les qualifient de "paradoxaux".

Nous avons rencontré des risques négatifs de leucémie (§ 3) ou de tumeurs thyroïdiennes (§ 4) sur des observations cliniques ; sans doute parce que les effectifs étaient insuffisants, ils ne diffèrent pas de zéro de façon statistiquement significative. Des expérimentateurs en ont bien mis en évidence, de façon statistiquement significative ; nous rapporterons les résultats de deux travaux qui portent, l'un sur la cancérogénèse, l'autre sur la génétique, parce qu'ils ont aussi le grand mérite de permettre de montrer la dualité des risques ajoutés par la stimulation due à l'irradiation (il en est sans doute de même pour toute autre cause de stimulation). Mewissen et Rust (1976), sur tous les lots de souris qui avaient reçu de 18 à 141 rems, ont trouvé que si le risque est négatif pour le lymphosarcome, il est positif pour le réticulosarcome. Newcombe et McGregor (1975), en fécondant des œufs de truite par du sperme qui, préalablement, avait reçu 50 rems, ont trouvé que si le risque est négatif pour la diminution de fertilité du sperme et pour la mortalité embryonnaire, il est positif pour les malformations de la tête et des yeux.

## 6. CONCLUSION

L'interprétation statique du mode d'action des rayonnements ionisants a rendu bien des services aux chercheurs, notamment avec sa théorie des cibles. Cependant, l'hypothèse de proportionnalité du risque à la dose, qui en découle lorsque celle-ci est faible, risquerait, en particulier par des calculs prévisionnels, en accentuant encore le malaise nucléaire, de paralyser la recherche en radiobiologie, de contrarier les progrès de la radiologie, et de désorienter la radioprotection. Pour ce qui concerne cette dernière, rappelons, par exemple, que rien ne permet de penser qu'une dose de 3 rems sur 3 mois consécutifs puisse nuire à la santé de quiconque : elle paraît bien être prudemment "admissible" pour tous.

## REFERENCES

- AEC, 10 CFR, Part 50, 36 (1971) 11113 - 11117
- AEC, WASH 1258 (1973) 3 volumes, 1455 pages.
- Conard R.A., BNL 50424, Upton (1975) 154 pages.
- Conti E.A., Patton G.D., Conti J.E. and Hempelmann L.H., Radiology 74 (1960) 386 - 391.
- Court-Brown W.L. and Doll R. Special report series N° 295, HMSO, Londres (1957) 135 pages.
- ICRP, publication 9, Pergamon Press, Oxford (1966) 27 pages.
- Jablon S. and Kato H., T.R. 10-71, ABCCC, Hiroshima (1971) 323 pages.
- Mewissen D.J. and Rust J.H., IAEA - SM 202/217.
- Modan B, Baidatz D., Mart H. Steinitz R. and Levin S.G., Lancet (1974) 277 - 279.
- NAS-NRC, BEIR report, Washington (1972) 217 pages.
- Newcombe H.B. and Mc Gregor J.F., Rad. Res. 61 (1975) 519 - 525.
- Rallison M.L., Dobyns B.M., Keating F.R., Rall J.E. and Tyler F.H., Am. J. Med. 56 (1974) 457 - 463.

## THE RADIOLOGICAL QUALITY OF THE ENVIRONMENT IN THE UNITED STATES

Kurt L. Feldmann  
Office of Radiation Programs  
U.S. Environmental Protection Agency

## 1. INTRODUCTION

The Office of Radiation Programs (ORP) of the U.S. Environmental Protection Agency has the responsibility for monitoring and assessing the impact on public health and the environment of radiation from all sources in the United States, both ionizing and nonionizing. Therefore, ORP has initiated an annual program for radiological dose assessment to determine individual and population doses nationwide. This assessment will be published each year in the report Radiological Quality of the Environment (1). This information will provide direction for federal radiation protection activities by the analysis of radiation trends, identification of radiation problems, and support for establishing radiation guidance.

## 2. DATA ACQUISITION

The most efficient way for EPA to assemble the broad data base required to assess the radiation dose to the United States population is to fully use available data reported by other Federal agencies, States and nuclear facilities. Dose data were compiled in the following radiation source categories: ambient environmental radiation, technologically enhanced natural radiation, fallout, uranium fuel cycle, federal facilities, medical, occupational and industrial radiation, nonionizing radiation, and other miscellaneous sources. These data were reviewed for adequacy and gaps were found which indicate areas of concern for future dose assessments. At the same time, areas were defined for which additional data collection is not warranted with respect to the small dose contribution from that source.

A special effort was made to acquire real data supported by direct measurements. Where these data were not available, however, estimated doses involving numerous assumptions were used. An attempt was made to compile the latest data that could be found for each source, therefore the data discussed in this paper represents the time period from the late 1960's to 1975. All data extracted from the literature were assumed to be valid and no attempt at confirmation of the data was made. The data and its origins were discussed in great detail in the 1976 report (1).

## 3. DISCUSSION OF RESULTS

The individual and population dose data resulting from the various categories of radiation sources are summarized in Table 1. The information in this table was divided according to whether the primary mode of exposure was external or internal. Exposure to direct radiation from radionuclides in the ground, water, buildings, and air around us, or from radiation-producing machines, such as x-ray equipment and nuclear accelerators is considered external exposure. Exposures of this type usually result in a radiation dose to the whole body of the person exposed. In contrast, internal exposures occur when radioactive materials are inhaled, ingested, or occasionally absorbed through the skin. Internal exposures often result in a radiation dose to particular organs of the body, such as the lung, gastrointestinal tract, or bones.

Table 1 Summary of dose data from all sources

Source	External		Internal	
	Individual dose (mrem/y)	Population dose (person-rem/y)	Individual dose (mrem/y)	Population dose (person-rem/y)
Ambient ionizing radiation	-	9.7x10 <sup>6</sup>	-	-
Cosmic radiation	40.9-45	9.7x10 <sup>6</sup>	-	-
Ionizing component	28-35.3	9.2x10 <sup>6</sup>	-	-
Neutron component	0.33-6.8	4.9x10 <sup>5</sup>	-	-
Worldwide radioactivity				
Tritium	-	-	0.04	9.2x10 <sup>3</sup>
Carbon-14	-	-	1.0	-
Krypton-85	4x10 <sup>-4</sup>	80	-	-
Terrestrial radiation	30-95	-	18-25	-
Potassium-40	17	-	16-19	-
Tritium	-	-	4x10 <sup>-3</sup>	-
Carbon-14	-	-	1.0	-
Rubidium-87	-	-	0.6	-
Uranium-238 series	13	-	2-3	-
Thorium-232 series	25	-	2-7	-
Technologically enhanced natural radiation	-	-	-	2.73x10 <sup>6</sup>
Ore mining and milling	-	-	-	-
Uranium mill tailings	-	-	8140-14000	2.5-70000
Phosphate mining and processing	-	-	-	-
Thorium mining and milling	-	-	-	-
Radon in potable water supplies	-	-	-	-
Radon in natural gas	-	-	54	2.73x10 <sup>6</sup>
Radon in liquified petroleum gas	-	-	0.9-4.0	30000
Radon in mines	-	-	-	-
Radon daughter exposure in natural caves	-	-	-	-
Radon and geothermal energy production	-	-	-	-
Radioactivity in construction material	-	-	-	-
Fallout	6, 2	-	-	-
Uranium fuel cycle	-	2014	-	-
Mining and milling	-	-	4.5x10 <sup>-2</sup>	2.5
Fuel enrichment	0.17	14	84.8-8.0	134
Fuel fabrication	-	-	12x10 <sup>-3</sup>	13
Power reactors	54 max 42 max	1552 155	-	-
BWR				
PWR				
Research reactors	-	-	-	-
Transportation - Nuclear power industry	-	100	-	-
Radioisotopes	-	270	-	-
Reprocessing and spent fuel storage	5.8	23	-	-
Radioactive waste disposal	-	-	-	-
Federal facilities	-	480	-	-
ERDA facilities	13-320	8x10 <sup>-7</sup> to 196	-	-
Department of Defense	< 0.01	-	-	-
Accelerators	0.04-4	3.42-65	-	-
Radiopharmaceuticals-production and disposal	0.2	0.083	-	-
Medical radiation				
X radiation	20	-	-	-
Radiopharmaceuticals	-	-	-	93.3x10 <sup>6</sup>
Occupational and industrial radiation				
BWR	1230	-	-	-
PWR	1080	-	-	-
All occupations	0.80	-	-	-
Consumer products		~6100		
TV	0.025-0.043	-	-	-
Timepieces	-	~6100	-	-

Individual exposure (μR/cm<sup>2</sup>)

Nonionizing electromagnetic radiation  
Broadcast towers and airport radars  
All sources

10  
0.1-1

a Lung dose  
b Lung-rem/y  
c Trachea-bronchial dose  
d 50 year dose commitment divided by 50  
e Average individual lung dose within 80 km  
f Maximum potential exposure  
g Maximum potential exposure to lung  
h Cumulative exposure within 40 mile radius  
i Average individual lung dose within 80 km  
j Fence line boundary dose  
k Within a radius of 80 km  
m Estimated for the year 1973  
n For Nuclear Fuel Services  
o Based upon data from 5 institutions  
p Millirad/y (genetically significant dose)  
q Estimated 1980 dose  
r Average occupational exposure per year  
s Average exposure for all occupations and 3.7 radiation workers/1000 persons in United States  
t 5 cm from TV set; units of mR/h  
- = No dose data available

It is evident from this table that there are radiation sources for which data are either incomplete or not available. Also, it is worthwhile noting that although population doses from the different source categories, in general, can be added together to gain a perspective of overall impact, it does not necessarily follow that individual doses can be added together because an individual in one population group generally does not receive the radiation dose common to another population group. For this reason, totals are shown in table 1 only for population doses in the various source categories.

### 3.1. Population Dose

It is apparent from this table that the external population dose from ambient ionizing radiation greatly exceeds the external dose from each of the other categories of radiation sources. This is especially true when one considers that the indicated population dose of approximately 10 million person-rem per year is due almost entirely to cosmic radiation and does not include the population dose attributable to terrestrial radiation. It is estimated from the external individual dose column that the terrestrial radiation dose may be approximately equal to or greater than the population dose due to cosmic radiation.

Internal sources of significant population dose for which we have data are from (1) the use of radiopharmaceuticals for medical radiation purposes, which is estimated to contribute approximately 3 million person-rem per year to the population dose, and (2) technologically enhanced natural radiation which also contributes approximately 3 million person-rem per year to the population dose. Finally, it is of interest to note that all the doses from all the other source categories for which data are available are less than 0.1 percent of the total population dose.

It is important to note that the population dose values mentioned here are based upon the data available to us at this time. It is quite possible that these values and thus, the relative contributions of population dose from the source categories considered, could change in the future as more information on this subject becomes available.

### 3.2 Individual Dose

The largest internal or external dose received by an individual was found to be an internal dose derived from technologically enhanced natural radiation. Inhalation of radon daughter products from uranium mill tailings resulted in a dose of 140 to 14,000 mrem per year to the tracheobronchial surface tissue of the lung. The second largest individual dose is received by individuals through their occupations. Approximately 1200 millirem of whole body dose per year is normally received by maintenance personnel working around a boiling water nuclear power reactor. Maintenance personnel working around a pressurized water reactor received the next largest individual dose. The fourth largest individual dose, approximately 320 millirem per year, would be received by an individual at the boundary of a federal facility. The next largest dose, about 120 millirem per year, is an average value due to ambient ionizing radiation. The individual doses from all other sources were less than half the dose due to ambient ionizing radiation. As has been mentioned earlier, the relative contributions from each of the source categories are subject to revision as may be required by new data.

#### 4. CONCLUSIONS

On the basis of the population dose data acquired for this report, the three major sources of radiation dose to the United States population are cosmic radiation, the application of radiopharmaceuticals in medicine, and the exposure to radon and radon daughters from the burning of natural gas. The reason for these relatively high population dose values is due to the large populations that are exposed to these sources.

On an individual basis, the sources of greatest dose are from the exposure to technologically enhanced natural radiation, the occupational exposure to boiling water and pressurized water nuclear power reactor maintenance personnel and the dose an individual would receive at the boundary of a federal facility. The factor that keeps the population dose low in the Occupational and Industrial Operations category and the Federal Facilities category is the relatively small number of people exposed to the sources in these categories. The source responsible for high individual doses in the category of Technologically Enhanced Natural Radiation is uranium mill tailings that had been used in the construction of residences. It is quite conceivable that, if data from other sources in this category were available, additional high individual doses would be observed.

There are many gaps in the dose data in the table. For example, it is generally accepted that the use of x rays in medicine contributes to a large and significant population dose. However, the magnitude of this population dose has still not been determined. For this reason, the resulting observations and comments are necessarily restricted to a limited data base. This indicates a need to greatly improve the data base for future dose assessments.

#### 5. FUTURE EFFORTS

The radiological quality of the environment will be determined on an annual basis. Future reports will update this effort and place more emphasis on treatment or analysis of available data and trend evaluations. An analysis of environmental concentrations of radionuclides may also be considered in subsequent reports in addition to dose information.

#### REFERENCE

- (1) U.S. ENVIRONMENTAL PROTECTION AGENCY, OFFICE OF RADIATION PROGRAMS. Radiological Quality of the Environment (Feldmann, K. L., Ed.), EPA-520/1-76-010, U.S. Environmental Protection Agency, Office of Radiation Programs, Washington, D.C. 20460 (May 1976).

PROGRESS IN BASIC PRINCIPLES OF LIMITATION  
IN RADIATION PROTECTION.

P.V.Ramzaev, S.I.Tarasov, M.N.Troitskaya, A.P.Ermolaeva

Institute of Radiation Hygiene, Leningrad, USSR

Summary

For the purposes of dose limitation a new quantity of health is proposed for a sum total of weighted socially significant indices.

The objective of any limitation system in application to potentially harmful factors including ionizing radiation should be to avoid their detrimental effects completely and, if possible, to achieve maximum public and individual benefit.

The present systems of limitation basically differs in choice of methods and in completeness of harm and benefit measurements.

The necessity of such measurements in any activity arises for estimation:

- a) of benefit (X) from the activity;
- b) of harm from the limitation as a result of detrimental residual effect of the chosen limit ( $Y_1$ ) and of harm from the protection measures providing the limit ( $Y_2$ );
- c) of difference ( $Z_1$ ) between benefit (X) and harm ( $Y_1 + Y_2$ ) from the activity at the chosen limit in comparison with similar differences from other alternatives ( $Z_2, Z_3 \dots$ ).

Then may arise the necessity of comparison between benefit from the achieved purpose (if it is not ultimate) and the one from other purposes. Relation of the above terms, two of which ( $Y_1 + Y_2$ ) are functions of the chosen limit, is reiterated in ICRP publications and may be expressed by a formula of limitation:

$$X - (Y_1 + Y_2) \geq Z_{2,3,4,\dots} \quad (1)$$

The simplest limitation system that is based on threshold principle and widely used to chemical agents proceeds from a requirement  $Y_1 = 0$  ignoring all other terms of equation 1. The limitation system known by its principle of "acceptable risk" is based on assumption  $Y_1 = A$ , where "A" is some value of probable harm, e.g. in form of death-rate from carcinogenesis comparable with death-rate in other activities.

As appears from equation 1 both systems do not meet the requirements of the ultimate aim of limitation because the benefit and harm of the limits and systems themselves are not determined.

The main difficulties of both systems as well as of ideal solution of equation 1 lies in nearly infinite variety of incomparable quantities now used for harm and benefit measurements. The relation between dose and effect is expressed in a single quantity for dose and in the endless number of tests for effect. There is not a general quantity for effect which could be acceptable to measurement of deleterious and beneficial effects equally. There are more than 1,000 various biochemical tests in form of concentrations of ferments and other substances in different tissues. The number of tests for cells, organs and their sys-



tems increases. Moreover one can not estimate their quantitative importance for the socially significant values. To our mind a step to the solution of the above eternal problem must be made by classification of all biological tests on the base of their social significance and accessibility to estimation by every sensible person, who is the only owner of his life. As ultimate general index of both harm and benefit there may be the main value for society and individual, which is quantity of health (QH).

All biological tests should be divided into three categories:

- I) socially significant and intelligible for every man of sober mind indices as obligatory signs of health;
- II) medical tests which have significance and links with the first indices and are determined as a result of special medical examinations;
- III) "pure" biological tests, importance of which for assessment of QH is often not known even to the physicians themselves.

From time immemorial all nations relate to socially significant indices of health the following four only: life-time (Lt), integral of mental and physical capacity for work during life-time (W), integral of feelings (F) and reproduction of descendants (D). One can hardly expand this list because all other biological and medical tests from categories II and III are under absolute control of the first one for purposes of limitation. For example, any diagnosed disease is considered as such if it decreases one or more indices in category I. We do not know illnesses which do not meet the rule. Furthermore, the use of some tests (morbidity test) without control by the first category may even desorient limitation system and lead to doubtful conclusions. In witness we give an example of unreliable use of cancerogenesis in the system of dose limitation. In 4 groups six generations of white mongrel mice (male and female) were fed with mixture of  $^{90}\text{Sr}$  and  $^{137}\text{Cs}$  during all their life. Group I consumed  $1.5 \times 10^{-12}$  Ci of  $^{90}\text{Sr}$  and  $250.0 \times 10^{-12}$  Ci of  $^{137}\text{Cs}$  daily per mouse that delivered the absorbed doses of 0.5 rad for whole body and about 0.8 rad for endosteal cells per year. The groups II-III-IV consumed the mixture 10-100-1,000 times more. Group "0" was control. That represents a model of intake for a known arctic food chain. As appears from Table I the animals, which had osteosarcomas (86% of all carcinomas) in all groups, had for certain statistically and considerably (by 40%) longer life-time as well.

As stated above we suggest a quantity of health (QH) in the capacity of the united index for measurement of benefit and harm, representing a sum total of indices from category I weighted with each other. One of the conceivable version of such summing and weighing is given in a formula of health (expressed in years of a full life):

$$QH = \frac{0.7 (Lt + W + F + D)}{4}; \quad (2)$$

Lt, W, F and D are expressed in percentage, considering that 100% correspond to 70 years of life-time, to integral of average capacity for work or of feelings for an untouched group, probability (or fact) of giving birth to 2 healthy children. For living organism the estimations will have a prognostic nature or must be expressed relatively to the average estimations of untouched group.

The difficulties in determination of QH are comparable with its importance. All its characteristics need very careful weighing. Some of them can be measured through the tests of category II. When relations between dose and other "fruits" of activity on the one hand and the quantity of health on the other hand are obtained, one can solve the equation of dose limitation. In that case only it will be possible to turn a maximum permissible level of harmful agent into a level, which will guarantee maximum achievable health without use of its money equivalent.

Table 1. Life-time of mice in six generations with and without osteosarcomas

Group, N°	All mice in experiment		Mice with osteosarcomas	
	Amount, pieces	Life-time, days	Amount, pieces	Life-time, days
0	455	364 ± 15	2	577 ± 14
I	690	337 ± 47	23	480 ± 37
II	592	369 ± 27	18	524 ± 34
III	529	370 ± 22	27	498 ± 26
IV	570	353 ± 24	23	517 ± 25

## CRITERIA FOR RISK ACCEPTANCE: A HEALTH PHYSICIST'S VIEW\*

A. P. Hull  
 Safety & Environmental Protection Division  
 Brookhaven National Laboratory  
 Upton, New York U.S.A. 11973

## 1. INTRODUCTION

A controversy over the safety of nuclear energy has grown in the United States since about 1970 and has now spread to near worldwide proportions. This controversy has been fueled by a variety of issues. Initially in the U.S. the most prominent issue concerned the degree of hazard of low level radiation, in particular that associated with the nuclear fuel cycle. Since then attention has shifted successively to the reliability of emergency core cooling systems, the longevity of nuclear wastes, the possible misuse of radioactivity by terrorists and the potential for diversion of nuclear power produced plutonium to weapons fabrication. Underlying each of these issues has been the implication that the employment of nuclear power will entail an unacceptable risk to the public.

Seemingly, the public interest would be served by an agreement upon some very elementary yardsticks for risk acceptance. In common with others engaged in occupational and public health protection activities, health physicists must apply some operational criteria for the acceptability of risk. Their essence are contained in the statement of the objectives and purposes of the Health Physics Society. They are suggested as a useful model for a general approach.

## 2. CRITERIA FOR RISK ACCEPTANCE

The stated primary objective of the Health Physics Society is "the development of scientific knowledge and practical means for the protection of man and his environment from the harmful effects of radiation, while encouraging its optimum utilization for the benefit of mankind" (1). This statement embodies or implies some very common sense criteria for risk acceptance.

1) All human activities, including the utilization of radiation, entail some risk. 2) The development of "knowledge and means" facilitates the minimization of risk. 3) The acceptance of risk should be evaluated in the context of offsetting benefits. It follows that no risk should be accepted for which there is not an apparent benefit. 4) An agent or activity that entails some risk should be utilized so that it offers an optimum benefit. It follows that it should not be utilized if a lower risk agent or activity offering the same benefit is available.

Given that each of us has an individual set of preferences and values, and that none of us has a right to force our set on another, the ICRP's philosophy of keeping risks from radiation less than or equal to risks "regularly accepted in everyday life" (2), seems the only available objective basis for societal judgements about risk acceptance. Any other approach risks ideological strife, as documented by the quasi religious overtone of much of the current argument about the acceptability of nuclear power (3). Thus a pragmatic secular approach to risk acceptance involves three simple questions: 1) What are the benefits? 2) What are the risks? How do the risks compare with those of alternatives? With regard to nuclear power, the

---

\*Research supported by the U.S. Energy Research and Development Administration.

benefits (electricity) are the same, regardless of fuel. So the principal remaining issue is the comparative risks of the alternative cycles.

### 3. RISK COMPARISONS

For a large scale employment of nuclear power by the year 2000, an associated average individual dose to the U.S. population of 0.0005 rem/yr has been projected by the Environmental Protection Agency (EPA)(4). This is compared to other significant radiation sources in Table 1. It is evident that the "other environment" dose, principally from the nuclear fuel cycle, is expected to remain small compared to natural and medical radiations, and to be comparable to that from such miscellaneous sources as color television, luminous time pieces and air transportation (the benefits of which seem somewhat less than having an assured supply of electricity).

Radiation source	Year				
	1960	1970	1980	1990	2000
	(mrem/yr)				
Environmental					
Natural	130	130	130	130	130
Fallout	5.5	4.0	4.6	4.7	5.0
Other*	0.08	0.06	0.09	0.22	0.47
Subtotal	135.6	134.1	134.7	134.9	135.5
Medical					
Diagnostic	72.3	72.3	72.3	72.3	72.3
Pharmaceuticals	0.3	2.0	13.9	14.2	15.6
Subtotals	72.6	74.3	86.2	86.5	87.9
Occupational	0.8	0.8	0.8	0.9	0.9
Miscellaneous	1.9	2.7	2.2	1.2	1.1
Total	211	212	224	224	225

TABLE 1 Average Annual Radiation Doses in the United States--1960 to 2000\*

\* Principally the nuclear fuel cycle.

\*\*Adapted from A. W. Klement, et al. (4).

If not satisfied at this point that nuclear power is acceptable, one may ask, "How do its risks compare with those posed by the alternatives?" From the dose-effect estimates made by the National Academy of Sciences-National Research Council Committee on the Biological Effects of Ionizing Radiation (BEIR)(5), an "extra" risk of fatal cancer of about 1/10,000,000 may be calculated for an individual exposed to 0.0005 rem/yr (from nuclear power in the year 2000). The U.S. Nuclear Regulatory Commission's (NRC) Reactor Safety Study (6) leads to a "most probable" risk (for low dose rate radiation) of 2/100,000,000, with a lower bound which does not exclude zero. The integrated risk of immediate fatal effect to the average individual in the U.S. from nuclear malfunctions, as given by the Reactor Safety Study, is for the 100 postulated reactors, only about 5/1,000,000,000 per yr, so that it adds little to the above estimate.

The attention currently being devoted to risk reduction in the NRC Appendix I regulations and EPA nuclear fuel cycle standard, seems out of proportion to its contribution to the overall current or prospective exposure to the public. Terrill has estimated that monies spent on improved x-ray equipment would accomplish from 1000 to 6000 times as much exposure reduction as the same amount spent on reactor waste treatment systems (7). Something needs re-examination when the driving forces in the debate about the merits of nuclear

energy produce such a misallocation of resources to the reduction of already trivial risks.

Several estimates of the health risks of the fossil fuel cycles have appeared recently in the literature (8-10). From them it appears that the associated average risk of premature fatal effect to individuals in the U.S. public is in the order of 2/100,000/yr, or about 200 times the "upper limit" nuclear risk. Additionally, there is epidemiological evidence in which cancer rates are positively correlated with urbanization and more pertinent to this consideration, with air pollution, much of which is associated with fossil power effluents (11,12). There appears to be a negative correlation with background radiation levels (13,14). From these indications the utilization of nuclear power would provide a net benefit to public health, and thus be not only "acceptable" but "desirable."

#### 4. CONCLUSION

While the currently available information is insufficient to establish numerical risk estimates for nuclear wastes, terrorism or diversion, the probable consequences do not appear as severe as suggested by some critics (15-18). Finally, in deciding on the acceptability of risk from nuclear power, one may ask "How do the national resources currently being allocated to still further reducing the 1/10,000,000 or so yearly hypothetical prospective risk from nuclear power compare with those resources being devoted to the overall prevention of premature death?" Some common risks are shown in Table 2.

Cause	Annual Risk	Cause	Annual Risk
All causes	$8.96 \times 10^{-3}$	Influenza	$2.70 \times 10^{-4}$
Diseases of heart	$3.39 \times 10^{-3}$	Diabetes	$1.68 \times 10^{-4}$
Malignant neoplasms	$1.74 \times 10^{-3}$	Cirrhosis of liver	$3.51 \times 10^{-4}$
Cerebrovascular disease	$9.18 \times 10^{-4}$	Arteriosclerosis	$1.37 \times 10^{-4}$
Accident (total)	$4.81 \times 10^{-4}$	Mortality in early infancy	$1.28 \times 10^{-4}$
Motor vehicle	$2.09 \times 10^{-4}$	Suicide	$1.26 \times 10^{-4}$
Falls	$7.20 \times 10^{-5}$	Bronchitis	$1.19 \times 10^{-4}$
Drowning	$3.80 \times 10^{-5}$	Homicide	$1.02 \times 10^{-4}$
Fire	$3.00 \times 10^{-5}$	Congenital abnormalities	$6.70 \times 10^{-5}$
Poisoning (solids and liquids)	$1.90 \times 10^{-5}$	Nephritis and nephrosis	$3.90 \times 10^{-5}$
Suffocation	$1.50 \times 10^{-5}$	Peptic ulcer	$3.20 \times 10^{-5}$
Firearms	$2.50 \times 10^{-5}$		
Poisoning (gases)	$1.60 \times 10^{-5}$		
Natural phenomenon	$3.10 \times 10^{-6}$		
Electrocution	$2.50 \times 10^{-6}$		

TABLE 2 Annual Death Risk from Leading Causes, United States\*

\* From Monthly Vital Statistics Report, Annual Summary for the United States, 1975, (HRA)-76-1120 24: 13 (6/30/76) except estimates of subcategory of accident from U.S. National Safety Council, Accidents Facts, 1976 edition.

It seems obvious that we cannot solve every health problem simultaneously both for lack of sufficient monies and sufficient knowledge. The determination of the priorities for their address and the determination of acceptable risk from each seems a matter of public policy. In terms of its relative risk, nuclear power appears to be more than "acceptable."

Beyond making these kind of comparisons, it may be suggested that the public would benefit from some kind of consensus about negligible nonzero levels

of probable risk which would be deemed generally acceptable. A reasonable perspective in this regard, suggested by Starr (19) is a yearly risk of  $1 \times 10^{-6}$ , the level of natural hazards (such as earthquakes, floods, hurricanes, and tornados). A similar "cut off," with regard to major accidents and their consequences has recently been advocated by Farmer (20) on the basis of existing social decisions (i.e. flood defenses) and the lack of experience to justify a lower level. Following a satisfactory demonstration of its achievement, hopefully the nuclear argument could be terminated. Society could then move on to the real issues affecting energy, population and quality of life.

#### REFERENCES

- (1) Membership Handbook, Health Physics Society. Originally adopted in 1969, contained in subsequent yearly handbooks.
- (2) Recommendations of the International Commission on Radiological Protection, ICRP Report No. 9, Pergamon Press, Oxford (1966).
- (3) MAXEY, M. N., Exorcising nuclear demony: ethics vs ideological politics, Atomic Industrial Forum, Washington, D. C. (1976).
- (4) KLEMENT, A. W., et al., Estimates of Ionizing Radiation in the United States, 1960-2000, ORP/CSD 72-1 (1972).
- (5) The Effects on Populations of Exposure to Low Levels of Ionizing Radiation, Report of the Advisory Committee on the Biological Effects of Ionizing Radiation, NAS-NRC, Washington, D. C. (1972).
- (6) Reactor Safety Study, Appendix VI, WASH-1400 (1975).
- (7) TERRILL, J. C., Cost benefit estimates for the major sources of radiation exposure, Amer. J. Public Health 62 (1972) 1008.
- (8) LAVE, L. B., The health effects of electricity generation from coal, oil and nuclear fuels, Nucl. Safety 14 (1973) 409.
- (9) STARR, C., GREENFIELD, M. A., Public Health Risks at Thermal Power Plants, UCLA-ENG-7242 (1972).
- (10) HAMILTON, L. D., MORRIS, S. C., Health effects of fossil fuel power plants, In Symp. on Population Exposures, CONF-741018 (1974) 305.
- (11) FORD, A. B., Urban factors in relation to cancer, Ann. Mtg., American Public Health Association, Chicago (1975).
- (12) MORTON, W. F., et al., Geographic pathology of lung cancer in Portland, Ann. Mtg., American Public Health Association, Chicago (1975).
- (13) FRIGERIO, N. A., Carcinogen Hazard from Low Level, Low Rate Radiation, ANL/ES-26, Part I (1973).
- (14) JACOBSON, A. P., et al., The role of natural radiation in human leukogenesis, Amer. J. Public Health. 66 (1976) 31.
- (15) COHEN, B. L., Impacts of the nuclear energy industry of human health and safety, Amer. Sci. 64 (1976) 50.
- (16) CHESTER, G. V., Estimates of Threat to the Public from Terrorist Acts Against Nuclear Facilities, ORNL NS 17(5) 1B (1976).
- (17) GRENDON, A., Some Plutonium Fallacies, Donner Lab., University of California, Berkeley (1976).
- (18) WALSKIE, C., Nuclear safeguards, a perspective, Atomic Industrial Forum, Washington, D. C. (1976).
- (19) STARR, C., Social benefit vs. technological risk, Science 165 (1969) 1232.
- (20) FARMER, F. R., Letter to the Editor: Risk quantification and acceptability, Nucl. Safety 17 (1976) 4.

UN EXEMPLE DE SURVEILLANCE EN MILIEU DE TRAVAIL:  
LA DOSIMÉTRIE INDIVIDUELLE PAR LE SERVICE CENTRAL  
DE PROTECTION CONTRE LES RAYONNEMENTS IONISANTS

par J.P. MORONI, A. BIAU et P. PELLERIN  
Service Central de Protection contre les Rayonnements Ionisants  
B.P. 35 - 78110 LE VESINET

## 1. INTRODUCTION

La dosimétrie individuelle des travailleurs a permis d'atteindre les deux objectifs suivants:

- mesurer le risque local pour le maintenir au dessous des limites réglementaires,
- vérifier que les dispositions prises aboutissent effectivement à une réduction des doses et, par l'étude statistique, améliorer constamment la prévention des risques correspondants.

Il serait difficile à l'heure actuelle de trouver, pour les autres nuisances industrielles, un système de surveillance techniquement et administrativement aussi efficace.

La dosimétrie individuelle s'applique aussi bien à un cabinet médical qu'à une centrale électronucléaire. C'est certainement dans les grands centres nucléaires que les consignes de radioprotection sont les plus élaborées et les mieux respectées. A l'opposé, dans le secteur médical, l'industrie non nucléaire et la recherche, la situation est très variable, allant de l'organisation très correcte de la radioprotection, à l'absence totale et même au refus de la radioprotection.

## 2. RÉGLEMENTATION

La réglementation française repose sur la base des recommandations des organismes internationaux de radioprotection.

Le n° 12 de la CIPR concerne "Principes généraux de surveillance en radioprotection des travailleurs" [1]. De son côté, la Commission des Communautés Européennes a publié récemment des "Recommandations techniques pour la surveillance de l'exposition des individus à l'irradiation externe" [2]. En France, le décret du 15 mars 1967 et ses arrêtés d'application [3,4] d'une part, le décret du 28 avril 1975 pour ce qui concerne les travailleurs des centres nucléaires d'autre part [5] précisent les obligations des employeurs et les modalités d'application de la dosimétrie.

Ces textes confient au Service Central de Protection contre les Rayonnements Ionisants (SCPRI) un rôle d'élaboration et de normalisation des méthodes, tout laboratoire effectuant des mesures de dosimétrie devant se prêter "à toutes opérations d'intercomparaison que le SCPRI jugera utiles". De plus, le SCPRI est destinataire de l'ensemble des résultats "en vue de permettre les intégrations de dose indispensables". Ainsi, si le SCPRI distribue et traite actuellement dans ses propres laboratoires 55 000 dosimètres mensuels représentant environ 45 000 personnes surveillées, l'information qu'il recueille, et sur laquelle il fait porter les opérations de cumul et de statistiques, repose sur un total d'environ 70 000 personnes surveillées; il s'agit évidemment là d'une expérience exceptionnelle en matière de surveillance des nuisances industrielles.

### 3. L'ORGANISATION DE LA DOSIMÉTRIE AU SCPRI

Le nombre de dosimètres distribués mensuellement par le SCPRI est passé de 6 200 en janvier 1967 à 55 000 en janvier 1977. La distribution de ces dosimètres à plus de 7 000 établissements répartis sur l'ensemble du territoire national, leur collecte et les indispensables liaisons avec les Médecins du Travail concernés sont parmi les difficultés essentielles rencontrées dans la gestion de ce réseau. Les résultats, considérés comme données à caractère biologique couvertes par le secret médical, sont adressés au Médecin du Travail exclusivement, ainsi que l'exige la réglementation française [4].

La réglementation française impose, pour la surveillance individuelle des travailleurs, le dosimètre photographique [4]. L'utilisation de tout autre détecteur, tels que stylo-dosimètre ou dosimètre thermoluminescent ne peut donc être pratiquée qu'en association avec la précédente. Le SCPRI a, comme objectif essentiel dans ses opérations, la fiabilité: car, plus encore qu'une précision métrologique des mesures, c'est la nécessité d'éviter toute erreur d'appréciation de la dose ou sur l'identité du porteur qui doit être l'objectif essentiel. Il est classique de considérer comme très satisfaisante une fiabilité impliquant moins d'une erreur sur 10 000 mesures; c'est d'ailleurs cette dernière valeur qui est retenue par la Commission des Communautés Européennes. Le SCPRI s'est fixé comme objectif de réduire le taux d'erreur à moins de un pour 100 000 dosimètres, et, à l'heure actuelle cet objectif est largement atteint.

La précision métrologique des mesures n'est pas, par contre, une exigence essentielle pour la dosimétrie individuelle. La CIPR recommande elle-même que les mesures, pour les doses inférieures ou de l'ordre des limites maximales admissibles, soient évaluées avec une précision meilleure que -30 à +50%. Aucun système de dosimétrie de routine actuellement en service ou à l'étude ne permet d'assurer une précision atteignant l'ordre de quelques pour cent (précision qui serait d'ailleurs illusoire car la dose reçue par le dosimètre, seule connue, diffère de la dose délivrée aux différents organes de beaucoup plus de quelques pour cent).

Le SCPRI a entrepris l'évaluation des différentes causes d'incertitude; pour les doses inférieures aux limites maximales admissibles, l'incertitude globale totale est de -21% et +31%. Pour les doses élevées, des vérifications complémentaires permettent d'abaisser l'incertitude globale à  $\pm 10\%$ .

L'organisation poussée mise au point en quinze ans de gestion de la dosimétrie individuelle a conduit à minimiser le coût de ce service, sans en altérer, bien au contraire, la qualité. Pour 55 000 dosimètres mensuels la totalité des opérations est assurée par une équipe de 13 personnes.

Le SCPRI a depuis plusieurs années étudié les dosimètres thermoluminescents (TLD). A ce jour, 10 000 dosimètres de ce type sont utilisés au SCPRI, soit en supplément de la dosimétrie photographique individuelle, soit pour des applications particulières (dosimétrie d'environnement notamment). C'est donc l'une des plus grandes masses de TLD actuellement contrôlés régulièrement. Il résulte de cette étude, de manière certaine, que le dosimètre thermoluminescent est très loin d'égalier, pour la surveillance individuelle des travailleurs, le dosimètre photographique et le SCPRI n'entend pas, en conséquence, modifier dans un avenir prévisible sa position quant à l'utilisation isolée de ce dernier.

La raison essentielle de cette préférence est le nombre d'informations beaucoup plus important fourni par le dosimètre photographique. Outre que chaque TLD a sa réponse propre qui doit avoir été déterminé cas par cas avant usage, le dosimètre thermoluminescent ne donne que la seule dose. Au prix d'une complication importante et d'un prix de revient presque prohibitif, il peut fournir également quelques indications sur la nature du rayonnement. Le dosimètre photographique fournit de manière simple, en plus de la dose, de précieuses indications sur: la qualité du rayonnement, l'homogénéité du faisceau, les traces



possibles de contamination, l'orientation du faisceau et dans une certaine limite, le mode d'irradiation (instantané ou en plusieurs fois...). Toutes ces indications sont d'une grande importance lors des enquêtes qui suivent les irradiations importantes. Elles deviennent indispensables lorsqu'on veut déterminer les doses reçues par opération pour améliorer la radioprotection du poste de travail et éventuellement modifier ou perfectionner les installations dans ce but.

Car la surveillance des travailleurs par dosimétrie, en plus de l'irradiation individuelle des personnes exposées, renseigne sur l'état des installations, les habitudes de travail, et prévient souvent les situations nouvelles qui risquent d'apparaître. Le SCPRI a d'ailleurs réalisé dans de nombreux cas, grâce à une étude dosimétrique fractionnée de certaines opérations (notamment dans les centrales nucléaires et en milieu médical [6]) une véritable étude de postes de travail, et mis au point un type particulier de dosimètres photographiques adaptés à ce type de recherche, qui fera l'objet d'une prochaine publication.

De plus, le dosimètre photographique constitue un document définitif, précieux en cas de recours, alors que la lecture détruit, en pratique, l'information du dosimètre thermoluminescent, malgré toutes les tentatives faites pour pallier cet inconvénient.

Enfin l'argument de prix de revient, parfois avancé en faveur de la dosimétrie isolée par thermoluminescence, ne résiste pas à l'analyse; bien au contraire, le coût d'un TLD composé au moins de deux détecteurs non indéfiniment réutilisable et sujet à un taux de pertes non négligeable dans le cas de la surveillance d'une population diversifiée, rendrait prohibitif le coût de cette surveillance.

Que l'on y prenne donc garde: après un engouement dû à la nouveauté, un désintéressement des fabricants de TLD pourrait bien se faire jour, d'autant qu'il s'agit de techniques autrement plus complexes que celles qui conduisent à l'obtention de surfaces sensibles, et qu'il n'existe pas l'équivalent du gigantesque marché des films radiographiques pour servir de support à cette fabrication.

#### 4. RESULTATS STATISTIQUES

Depuis 1972, le SCPRI procède à l'étude statistique de l'ensemble des résultats annuels; ces études sont communiquées à l'UNSCEAR [7]. La dernière étude, porte sur les doses relevées durant l'année 1975 sur 23 000 travailleurs (des critères statistiques très stricts conduisent à éliminer une partie des données, notamment celles relatives aux personnes ayant eu un travail intermittent); la dose moyenne dans ces conditions est de 130 millirads par an (bien entendu, l'on fait abstraction des doses élevées pour lesquelles il a été prouvé qu'elles n'avaient pas été reçues par le porteur lui-même). Le tableau 1 montre la répartition des doses moyennes annuelles par intervalle de doses, le tableau 2 la répartition par type d'activité.

#### 5. CONCLUSION

La dosimétrie photographique individuelle est une arme majeure au service de la radioprotection, qui a atteint son but: réduire les doses reçues par les travailleurs, malgré l'augmentation des utilisations des techniques radiologiques et nucléaires. C'est ainsi qu'entre 1973 et 1975, la dose moyenne annuelle pour l'ensemble des activités est passée de 160 à 130 millirads.

Intervalle de dose (rad/an)	Pourcentage de travailleurs ayant reçu une dose comprise dans l'intervalle
0 - 0,5	93,6 %
0,5 - 1,0	3,8 %
1,0 - 1,5	1,6 %
1,5 - 5,0	0,9 %
> 5	0,1 %

Tableau 1 - Répartition générale des doses annuelles

Activité pratiquée	Nombre de personnes	Dose collective annuelle (rad-homme)	Dose moyenne annuelle (rad)
<b>MEDECINE</b>			
Radiodiagnostic	14 085	1 972	0,14
Radiothérapie et médecine nucléaire	3 771	754	0,20
Art dentaire	2 661	106	0,04
<b>INDUSTRIE ET RECHERCHE</b>			
Radiographie, gammagraphie, sources non scellées, applications non médicales	2 704	187	0,07
<b>TOTAL</b>	<b>23 221</b>	<b>3 019</b>	<b>0,13</b>

Tableau 2 - Répartition des doses par type d'activité

#### REFERENCES

- [1] ICRP - Publication 12 "General Principles of Monitoring for Radiation Protection of Workers" - Pergamon Press - OXFORD 1968.
- [2] Commission of the European Communities "Technical Recommendations for Monitoring the Exposure of Individuals to External Radiation" - EUR 5287 - Luxembourg 1975.
- [3] Décret n° 67-228 du 15 mars 1967 "Protection des Travailleurs contre les Rayonnements Ionisants" - J.O. Paris 1967.
- [4] Arrêtés d'application du 18 au 24 mai 1968 "Protection des Travailleurs contre les Rayonnements Ionisants" - J.O. Paris 1968 et particulièrement arrêté du 19 avril 1968.
- [5] Décret n° 75-306 du 28 avril 1975 "Protection des Travailleurs contre les Dangers des Rayonnements Ionisants dans les Installations Nucléaires de Base" - J.O. Paris 1975.
- [6] AMIEL M., CLERMONT A., JOCTEUR-MONROZIER D., MORONI J.P., BRUN P. "Etude dosimétrique au cours de l'angiographie cardiaque chez le jeune enfant" - Ann. Radiol. 1976, 19 (6), 623-628.
- [7] PELLERIN P. "Communication personnelle à l'UNSCEAR" - Vienne 1976.

THE CENTRAL DOSE REGISTER FOR THE NUCLEAR INDUSTRY IN SWEDEN

Carl-Olof Widefjell  
 AB ATOMENERGI, Studsvik  
 S-611 01 Nyköping, Sweden

1. INTRODUCTION

The central dose register for the nuclear industry in Sweden has been in operation since 1974. Before 1974 the register contained only Studsvik personnel. The system has today about 10 000 persons in the register.

2. DATAHANDLING

The dose information is together with personal information stored in the central computer at Studsvik, a CDC Cyber 172. All information to and from the system is handled via terminals at the different nuclear sites. The terminals are connected to the computer via ordinary telephone lines.

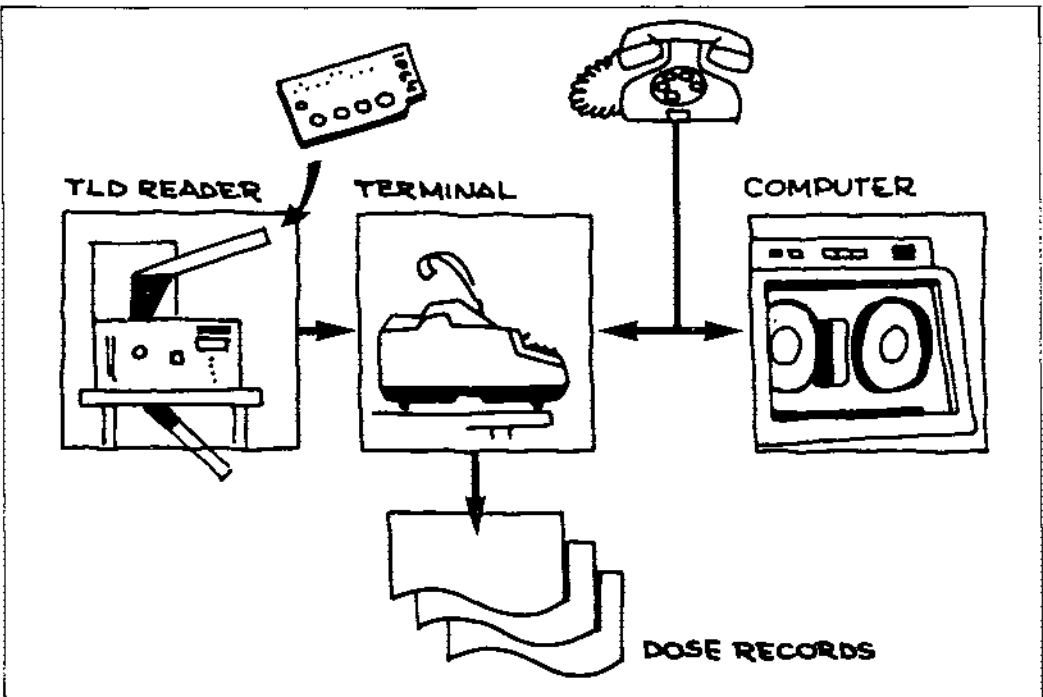

The Studsvik Dose Registration System

### 3. DOSIMETRY SYSTEM

Most doses handled by the system are personnel body gamma doses, which are recorded on TLD. Studsvik automatic TLD readers are used and the punched tape from the reader feeds the data via the terminal straight into the dose register.

Also hand and finger doses are recorded on TLD and read by the automatic TLD reader.

Internal doses as recorded by the whole body monitor or urine analyses are also handled by the dose register.

### 4. PERSONNEL IDENTIFICATION

In the dose register the dose information is stored under the person's unique social security number. For personnel from other countries their social security number is used together with the identification of the country. (According to the two letter code given in ISO 3166 (1975)).

### 5. CONTROL OF THE CALIBRATION OF THE TLD-SYSTEMS

A special routine is used for the supervision of the status of the TLD-systems.

Always when personnel doses are read calibration dosimeters are also read. The results from the calibration dosimeters are also handled by the computer. The computer compares the TLD reading with the nominal value and calculates a calibration factor. This calibration factor is then compared with previous factor. If the new factor deviates by more than 10 % a signal is given to the operator and the automatic registration of doses is stopped. If not the new calibration factor is used to figure out the doses.

This calibration control is a necessary safety procedure as recorded doses are registered without any manual handling.

### 6. AREA MONITORS

Area dosimeters are also handled by the system both from inside the site and from the environment.

From personal doses the normal background is subtracted. This is not the case for area dosimeters.

### 7. OUTPUT FROM THE SYSTEM

From the dose register it is possible to get a lot of different types of lists and statistics; for example

- a. Personal records which show the doses for months, quarter of the year, year and life for body gamma, beta and neutron doses, hand doses and internal doses.
- b. List for a department with all the doses of the month.
- c. List of doses received for a certain job.

- d. List of doses received by contractor personnel.
- e. Summary of doses for the year.

#### 8. CONCLUSIONS

This central dose register, operated by decentral terminals and used together with decentral TLD readers has many advantages:

- a. The register is as fast as possible updated.
- b. Data from the register can be obtained within seconds.
- c. Hot jobs can be supervised easily and without time delay due to dose communications.
- d. It is very easy to handle individual records for a large number of maintenance personnel moving from site to site. No radiological pass is needed.

THE SELECTION OF OCCUPANCY FACTORS

J.R.A. LAKEY  
 Royal Naval College  
 Greenwich, London, U.K.

1. INTRODUCTION

The control of external radiation exposure requires the application of the following three factors in both the design and the operation of the radiation facility

- a. Distance - distance between the working position and the source of radiation
- b. Shielding - a protective barrier between the working position and the source
- c. Time - exposure time limits so that dose limits are not exceeded when a worker occupies the working positions

This paper is concerned with the third factor - occupancy time - and attempts to show how the design, operation and exposure assessment are related to the selection of occupancy factors.

2. THE OCCUPANCY FACTOR

The designer of the facility can calculate, from equation 1, an exposure rate limit for the working position to be protected (1,2)

$$X_i = \frac{LC}{WU_i T_i} \text{ mr/hr} \quad \dots\dots\dots (1)$$

where  $X_i$  = exposure rate limit for the area  $i$

$L$  = exposure rate limit (local regulations) mr/week

$C$  = conservative factor

$U_i$  = use factor for area  $i$ , fraction of the time that radiation is directed towards the area  $i$

$T_i$  = occupancy factor - fraction of the time that the location is occupied when irradiated

$W$  = work load, hours per week that the facility is working

Local regulations may determine nearly all these quantities, for example, in the U.K. the Factories Act regulations permit an 'approved scheme of work' where it is not reasonably practicable to achieve 'adequate shielding'. In this case  $X_i$  will exceed  $\frac{L}{W}$  but limits will be set on  $X_i$ ,  $U_i$ ,  $T_i$  and  $W$ . Factor  $C$  is usually selected by the designer to accommodate unavoidable errors in his data and his design methods and is usually between 0.1 and 0.5. If  $U_i$  and  $T_i$  are permitted to fall below 1.0 the choice must be made with great care because it implies a separate work area and a deliberate redistribution of radiation exposure between different workers. Furthermore administrative controls must be effective and the operator must be aware of

potential errors in his exposure assessment.

### 3. INTERACTION BETWEEN DESIGNER AND OPERATOR

The designer is required to make decisions like those of a General who plans large military movements and operations; the designer decides the strategy of radiation exposure control whilst the operator of the facility is concerned with the tactical deployment of the radiation workers when the facility is operating. Like the General a designer is not aware of the detailed movements which will take place and the actual conditions of the planned operation may be very different from those assumed for the design. In this paper two aspects where both strategy and tactics are involved are discussed

- (i) radiation field gradient and the effect of errors in the position of the worker
- (ii) radiation field quality and the effect of errors in radiation dosimetry

The use of separate work areas with different occupancy factors calls for effective communication between designer and operator and the nature of the information required is proposed.

### 4. RADIATION FIELD GRADIENTS

In X-ray facilities where the radiation source is virtually a point there is a high rate of variations of radiation intensity with distance from the source. Radiation field gradients are typically 20% per metre along a radius from the source and, since radiation workers are not static, there are noticeable variations in exposure between the different workers (3). The designer may neglect the effect of worker movement by assuming that the worker is exposed at the position of the highest exposure rate in the area. This assumption is obviously unrealistic and a better model of the workers' movements is required. The designer can use a one dimensional model which simply specifies the mean position of the worker and then computes for that point. In two dimensions the model can be a plan on which the trajectory of the worker is described; the predicted radiation field superimposed on this plan can be integrated along the trajectory to give the exposure.

There is no significant advantage in going above 2 dimensions even for nuclear reactor designs. In any situation more complicated than one point source the computing task is formidable but the strategy produced is more effective in making cost effective use of the resources specified by the designer.

Tactics. Where field gradients are high the operator may deploy his workers so as to minimise the exposure. For example, let us assume a working area 5 metres across with a point source 3 metres outside one wall. Assuming radiation exposure obeys the inverse square law and considering only the distance from the source the table below shows the effect of the worker's position on his exposure.

TABLE I

POSITION	MEAN EXPOSURE RATE
At wall nearest to Source	1.0
At wall far from Source	0.14
Average over Whole Room	0.41
Front Half Room only	0.64
Rear Half of Room only	0.19

The table shows that confining the workers to the rear half of the room reduces exposure rates to half of those received when the whole room is accessible. The exposure in this case is about 40% of the maximum.

#### 5. RADIATION FIELD QUALITY

The shield designer normally computes exposure rates without reference to any instrumentation errors experienced by the operator. This factor could be important in areas where both the intensity and quality of the radiation field varies significantly (4). In this case significant variations in absorbed dose might be masked by false instrument readings. Large discrepancies between predicted exposure rate and radiation survey measurements will provide further confusion. Designers should at least indicate areas where potential errors of this type exist. The design predictions do not normally consider the effect of the radiation worker on the radiation field. For example over the range of gamma photon energies the survey instrument readings may be changed by a factor of 2 by the shielding effect of the body of the holder. The assessed value of the mean bone marrow dose can be as much as a factor 7 below the exposure recorded at the film badge position.

Tactics. With potential errors of this magnitude the operator might find that his attempts at exposure control reduce to a lottery - the workers absorbed dose might not correlate with exposure measurements. The operator should study the design predictions before deciding on radiation survey tactics and attempt spectrum measurements in regions where errors are likely to affect his decisions.

#### 6. THE APPLICATION OF OCCUPANCY FACTORS

If the design can be based on occupancy factors there will be at least two design exposure rate limits derived from values of  $U_i T_i$  in the relevant areas. For example, assume that there are two areas A and B with values of  $U T$  of 0.1 and 1.0. If  $C = 1$  and  $W = 40$  hours per week the design exposure rate limits will be 0.25L and 0.025L respectively. An individual worker confined to B would therefore receive the legal dose limit if he spends 40 hrs per week in B. Since A can be occupied for  $0.1 \times 40 = 4$  hours this individual could get L in A and in the remaining 36 hours a further 0.90L in B making a total of 1.90L. This is not acceptable and can be avoided by reducing the design exposure rate limits to 0.25L/1.9 and 0.025L/1.9. An alternative is to have an inequality which can be stated 'the occupancy of A cannot exceed 4 hours and must be reduced by 1/10 of the time spent in B.'



The possibilities for inequalities increase as the control extends to more areas and other constraints are added by limitation of cost, number of workers, internal radiation dose. The designers model of the facility becomes essential if the operator is to be given a warning on the consequences of failure of administrative controls.

## 7. CONCLUSIONS

The designers of radiation protection facilities must be made aware of their strategic rôle in the task of controlling radiation exposure. The designer should assist the operator by

1. taking account of the actual movements of radiation workers and predict exposure rates in all occupied spaces
2. nominating areas with high field gradients
3. nominating areas with abnormal radiation quality and indicating possible instrument errors

The operators must recognise their tactical rôle and be ready to take advantage of radiation field gradients, to be wary of changes in radiation quality and to ensure that their natural caution does not cause exposures to be unfairly distributed among workers.

## REFERENCES

1. Protection against Ionising Radiation from External Sources.  
International Commission on Radiological Protection - Report of Committee III, Publication No 21.
2. Medical X-ray & Gamma-ray Protection for Energies up to 10 MeV.  
National Council on Radiation Protection and Measurement  
NCRP Report No 38, 1970
3. The selection of Shield Design Objectives  
J R A Lakey  
Conference on Criteria for Radiation Protection IRPA  
Amsterdam, April 1975
4. Interpretation of Radiation Surveys on Operational Power Systems  
J R A Lakey and E W Spiers  
International Symposium on Radiation Protection - Philosophy and Implementation, Aviemore 1974  
Society for Radiological Protection

Copyright © Controller HMSO, London 1977

SURVEILLANCE RADIOTOXICOLOGIQUE DU PERSONNEL DE L'USINE  
DE SEPARATION DES ISOTOPES DE L'URANIUM DE PIERRELATTE =  
METHODES ET RESULTATS

J. CHAIBREYSSE

Institut de Protection et Sécurité Nucléaire - Département de Protection  
Laboratoire de Surveillance des Nuisances de l'Homme et de son Environnement  
Commissariat à l'Energie Atomique B.P. n° 38 - 26/00 PIERRELATTE

Le procédé de séparation des isotopes de l'Uranium utilisé en France à PIERRELATTE, repose sur le principe de la diffusion gazeuse = passage d'un composé gazeux, l'hexafluorure d'uranium, à travers une paroi poreuse. La vitesse de passage pour les molécules légères d' $^{235}\text{UF}_6$  et de  $^{234}\text{UF}_6$  étant plus grande que pour  $^{238}\text{UF}_6$  il s'ensuit un effet séparatif.

En répétant cette opération un très grand nombre de fois, on parvient à enrichir le flux gazeux en son isotope  $^{235}\text{U}$  et également  $^{234}\text{U}$  : on obtient ainsi l'uranium enrichi.

#### I. COMPOSES D'URANIUM AUXQUELS SONT EXPOSES LES TRAVAILLEURS

Dans une usine de séparation des isotopes d'uranium, telle que celle de PIERRELATTE, on rencontre des composés de nature chimique et de compositions isotopiques très différentes, ce qui complique notablement la surveillance des travailleurs. L'enrichissement de l'uranium en son isotope  $^{235}\text{U}$  s'accompagne d'un enrichissement plus important en  $^{234}\text{U}$ . L'uranium naturel de départ dont la composition en masse était de 99,28 % pour  $^{238}\text{U}$ , de 0,72 % pour  $^{235}\text{U}$  et de 0,0056 % pour  $^{234}\text{U}$  s'enrichit donc au fur et à mesure que le flux gazeux progresse dans les étages de diffuseurs en  $^{235}\text{U}$  et  $^{234}\text{U}$ . Il s'ensuit une variation relative de l'activité massique de mélanges isotopiques de teneur croissante en  $^{235}\text{U}$  et  $^{234}\text{U}$  : l'activité correspondant à une masse donnée est d'autant plus importante que le taux d'enrichissement est plus élevé. C'est ainsi que lorsque l'enrichissement de l'uranium est supérieur à 90 % exprimé en  $^{235}\text{U}$ , l'activité alpha est environ 100 fois celle de l'uranium naturel mais plus de 96 % de cette activité est due à  $^{234}\text{U}$  dont la proportion pondérale est d'environ 1 %.

D'un point de vue chimique, les principaux composés d'uranium rencontrés dans une usine telle que celle de PIERRELATTE sont l'hexafluorure et son produit de décomposition l'oxyfluorure d'uranium, le nitrate et le carbonate d'uranyle, les peruranates, le tétrafluorure et les oxydes d'uranium.

Les composés qui sont les plus susceptibles d'être ingérés ou inhalés sont l'hexafluorure (sous forme de gaz), l'oxyfluorure (sous forme de poudre ou d'aérosol soluble), le tétrafluorure et les oxydes (sous forme de poudre ou d'aérosol insoluble).

#### 2. METHODES DE SURVEILLANCE RADIOTOXICOLOGIQUE DU PERSONNEL

La surveillance radiotoxicologique du personnel de l'usine de PIERRELATTE met en oeuvre différents procédés :

- . mesure de l'excrétion de l'uranium dans les prélèvements biologiques (urines, selles) ;
- . évaluation de la contamination localisée au niveau de la poitrine.

##### 2.1. Contrôle des excréta

La mesure de l'uranium présent dans les échantillons biologiques s'effectue selon deux procédés techniques :

. fluorimétrie selon la méthode classique par fusion des sels d'uranyle avec du fluorure de sodium et de carbonate de sodium.

Cette technique est utilisée pour l'uranium naturel ou au stade faiblement enrichi (jusqu'à 5 à 8 %). La sensibilité de la méthode pour les urines est de 5 µg/l.

. comptage alpha pour l'uranium enrichi à un stade supérieur à 5 à 8 % en  $^{235}\text{U}$ . En effet la méthode fluorimétrique n'est plus sensible. Nous avons mis au point à PIERRELATTE une méthode originale dont le principe est le suivant :  
- séparation préalable de l'uranium des autres composés ou éléments gênants pour le comptage, par une résine échangeuse d'ions, liquide, l'Amberlite LA 2 (N-Lauryl - N - Trialkyl méthylamine). On utilise le complexe anionique  $\text{UO}_2\text{Cl}_4^{--}$  qui se forme lorsque l'ion uranyle est en milieu HCl 5 à 9 N, ce qui permet de séparer l'uranium des alcalins et alcalino terreux. Le procédé mis au point à PIERRELATTE évite l'habituelle et longue minéralisation des urines, mettant en jeu de grandes quantités d'acide difficilement utilisable en grande série.  
- mesure de la radioactivité alpha à l'aide d'appareils, passeurs automatiques d'échantillons (ionisation avec circulation argon-méthane).  
La sensibilité de la méthode pour les urines est de 10 pCi pour un comptage de 50 minutes pour une prise d'essai de 100 ml. Pour connaître la composition isotopique de l'uranium trouvé dans un prélèvement biologique, nous effectuons une analyse spectrométrique du rayonnement alpha émis par l'uranium. Au préalable, nous séparons l'uranium par passage sur résine liquide suivie d'une électrodéposition. Par ce procédé nous pouvons apprécier l'enrichissement de l'uranium trouvé jusqu'à un taux de l'ordre de 40 % en  $^{235}\text{U}$ . Au-delà l'imprécision est trop grande.

## 2.2 Mesure de la radioactivité au niveau de la poitrine

L'évaluation de la contamination en uranium localisée au niveau de la poitrine s'effectue à PIERRELATTE dans une chambre en plomb de faible activité. La cellule mesure 3 mètres de longueur, 2 mètres de hauteur et 1,50 m de largeur avec une surlargeur de 0,50 m au niveau de l'emplacement du détecteur. L'installation est opérationnelle depuis 1969. Sa sensibilité est d'environ 0,5 à 0,8 Q.M.A.

## 3. ORGANISATION DES CONTROLES RADIOTOXICOLOGIQUES

On effectue systématiquement des prélèvements d'urine sur les lieux mêmes du travail des agents : selon une fréquence définie en fonction du risque, nous faisons établir par l'ordinateur du Centre de PIERRELATTE une convocation pour prélèvement d'urine par l'agent. On pratique des contrôles d'équipe de travailleurs, c'est-à-dire que l'on convoque le personnel par roulement en désignant des individus dans des équipes différentes. Cette attitude s'est révélée parfaitement justifiée avec l'expérience. Un flacon pour le recueil des urines est mis à la disposition de l'agent sur les lieux de son travail. L'individu doit fournir un volume d'urine d'environ 200 ml : il ne s'agit donc pas du recueil de la totalité des urines de 24 heures ; on procède ainsi par sondages sur l'ensemble du personnel. A la date limite précisée sur la convocation, les fiocons d'urine sont ramassés par des agents du laboratoire. On ne tient pas compte de l'horaire de prélèvement des urines. On ne reconvoque pas les agents qui n'ont pas répondu à leur convocation. Il s'agit d'un contrôle ou d'un sondage par zone de travail. Les examens ne sont pas obligatoires. On considère qu'environ 30 à 35 % des agents ne répondent pas à leur convocation. Si l'examen systématique s'avère positif on déclenche un contrôle approfondi qui est équivalent à celui que l'on effectue après un incident.

Dans le cas d'un incident, le plus souvent par inhalation, on effectue le dosage de l'uranium dans l'échantillon d'urines recueillies immédiatement après l'inhalation, les urines de 24 heures suivant l'inhalation, les selles des 72 heures et éventuellement une mesure de la radioactivité localisée au niveau de la poitrine.

#### 4. RESULTATS

##### 4.1 Surveillance systématique

D'emblée on peut dire qu'il n'a jamais été mis en évidence de contamination interne due à l'uranium, décelable par mesure de la radioactivité au niveau du poumon.

On décèle de temps en temps des urines dites positives au cours des examens systématiques. Elles proviennent d'agents affectés à des postes de travail pour la récupération et l'élaboration du métal uranium enrichi. Les valeurs mesurées sont toujours inférieures aux limites maximales admissibles et ne nécessitent pas d'éviction de poste ou de mise au repos.

Il ne s'agit pas, en fait, d'une contamination chronique à bas niveau, mais plutôt de petits incidents qui sont inaperçus, et que seuls les examens d'urines permettent de mettre en évidence.

##### 4.2 Surveillance après incident

Un incident, que l'on peut qualifier d'historique, s'est produit en 1965 dans l'usine pilote du Centre de PIERRELATTE. Cet incident n'a eu heureusement aucune conséquence fâcheuse pour le personnel. Celui-ci était alors en service de jour, et bien qu'il n'y ait pas eu d'agents sérieusement atteints, il a été décidé, afin de parfaire nos connaissances dans le domaine de la protection, de contrôler un nombre très large de personnes. Cette méthode avait eu outre l'avantage d'éviter qu'il y eut par hasard un individu non contrôlé et susceptible à l'extrême limite d'avoir été intoxiqué.

Le composé d'uranium était l'hexafluorure d'uranium naturel.

- . 115 personnes furent directement exposées
- . 323 personnes étaient dans les parages de l'incident
- . 396 personnes participèrent à la décontamination des locaux ou du matériel.

Les nombreux contrôles opérés sur ce nombre relativement élevé d'agents ont permis l'établissement de statistiques intéressantes sur l'élimination de l'uranium inhalé par certaines personnes à des doses légères.

Cet incident est rapporté en détail par ailleurs (1) (2)

#### 5. CONCLUSION

En conclusion générale on peut dire :

. qu'une surveillance radiotoxicologique très serrée et très sévère est effectuée sur le complexe industriel de PIERRELATTE. Cette surveillance est adaptée aux postes de travail c'est-à-dire aux risques existant réellement pour le travailleur ; la périodicité des contrôles est fonction du risque.

que cette surveillance bien codifiée et bien organisée est fort bien acceptée du personnel qui collabore fort efficacement avec les équipes du laboratoire.

Dans un complexe industriel tel que celui de PIERRELATTE, et, bientôt, celui du Tricastin, cette surveillance radiotoxicologique se complique du fait de l'existence de mélanges de compositions isotopiques différentes et de nature chimique variée.

. que la technologie et la conception des installations assurent une très bonne prévention : le C.E.A. a su comprendre et résoudre des problèmes liés à l'hygiène du travail, ce qui a permis le développement de l'énergie nucléaire, car, en définitive, pour toutes les questions d'hygiène, de sécurité, de nuisances professionnelles il faut faire sien le vieil adage : "Mieux vaut prévenir que guérir".

La surveillance radiotoxicologique, telle qu'elle est conçue à PIERRELATTE, et d'une façon générale au C.E.A., est un élément des plus nécessaires et des plus fondamentalement utiles à cette prévention.

#### REFERENCES

- (1) J. CHALABREYSSE "Etude et résultats d'examens effectués à la suite d'une inhalation de composés dits solubles d'uranium naturel", Radioprotection (1970) 5 1, 1-17
- (2) J. CHALABREYSSE "Etude et résultats d'examens effectués à la suite d'une inhalation de composés dits solubles d'uranium naturel", Radioprotection (1970) 5 4, 305-310

DETERMINATION OF THE RADON DAUGHTERS CONCENTRATION IN JAPANESE URANIUM MINE ATMOSPHERE BY MEANS OF WEIGHTED LEAST SQUARES

Ryuhei KUROSAWA

Science and Engineering Laboratory Waseda University  
17 Kikui-cho, Shinjuku-ku, Tokyo, JAPAN

1. INTRODUCTION

The accuracy of the determination of the individual radon daughters concentration mainly depends on the selection of time period and its interval in the Tsivoglou and similar gross alpha counting methods. To determine the concentration of the daughters, several selections of the counting period and interval have been proposed by some investigators, however, these selections are not always suited for determination of various existing rate of radon daughters particularly under the condition of extreme low disequilibrium.

The proposed method employs an air sampler (flow rate of about 15 l/min), a membrane type air filter (millipore DA; pore size 0.65 μm) and a ZnS scintillation alpha counter. The specified collecting time of 3,5 and 7 min. (selectable) provided for the radon daughter collection in the sampled air. After collecting, total alpha counts is measured at the following six time periods and intervals; 2 - 6, 7 - 11, 12 - 16, 17 - 21, 22 - 26 and 27 - 31 min. From end of collecting. The individual concentration of the daughters are calculated by means of weighted least squares method using the above counting data and these errors are estimated based upon the statistical conceptions.

2. MEASUREMENT OF RADON DAUGHTERS

2.1 Counting Efficiency

The intrinsic detecting efficiency of a ZnS scintillation detector for an alpha particle is 100 %, but the actual counting efficiency depends on the discriminating level of a counting device, geometrical arrangement between a detector and radiation source such as a filter paper deposited radon daughters and distribution of the deposited radon daughters along with the sampling air flow. The distribution function  $\phi(t)$  is estimated by means of the alpha energy analysis as follows:  $\phi(t) = 10.2 \exp(-0.875t) + 3.56 \exp(-0.125t)$ . Where  $t$  is the depth of deposited position from filter surface in mg/cm<sup>2</sup>. The actual counting efficiency is the product of the correction factor  $f_d$  due to the distribution above mentioned and the counting efficiency  $\eta$  which is determined by comparison with a standard alpha source measurement.

2.2 Back Ground Counts

The back ground counts  $M_{Bi}$  at the each counting period (No. i) is estimated as follows:

$$6 \approx (M_{B1} + M_{B2}) ; M_{B2} = (M_{B1} + M_{B2}) / 2$$

$$M_{B1} \approx M_{B1} \exp(-\lambda_{B1}(T_{B1} + T_{B2} + 31)) ; M_{B2} = \frac{1}{2} \left\{ \frac{M_{B2}}{\exp(-\lambda_{B2}(T_{B1} + T_{B2} + 31))} + M_{B1} \right\} \times \exp(-\lambda_{B1}(T_{B1} + T_{B2} + 31))$$

$$M_{B1} \approx M_{B1} \exp(-\lambda_{B1}(T_{B1} + T_{B2} + 31)) ; M_{B2} = (1) \times (1 - \frac{7c}{0.5}) \left( \frac{M_{B2} - M_{B1} \exp(-\lambda_{B1}(T_{B1} + T_{B2} + 31))}{6 \times n_b} \right)$$

$$N_{BPF} \exp(-\lambda_{BPF}(T_{BPF} + 2 + 5 \times (1 - 1)))$$

Where  $M_{BPF}$  is a back ground count (counts/ 4 min.) at the  $T_{BPF}$  min before sampling end.

$M_{BPF}$  is a back ground count ( counts/ 4 min.) at the  $T_{BPF}$  min after end of the No. 6 counting period.

$M_{P1}$  is a back ground count (counts/ 4 min.) at the No.1 counting period.

$m_1$  is a gross alpha count (counts/ 4 min.) of collected radon daughters at the No.1 counting period.

$\lambda_{BPF}$  is the effective decay constant of the contaminated radon daughters to the surface of ZnS scintillator;  $0.01925 \text{ min}^{-1}$

$\zeta_c$  is the actual counting efficiency of the ZnS scintillation counter for  $^{210}\text{Po}$  alpha particle deposited in the filter.

### 2.3 Growth of Alpha Activity

The growth of the alpha activity of the individual radon daughters under the constant collecting rates is calculated by following equations (1)-(4) as the function of  $T_c$ .

$$\left(\frac{^{210}\text{Po}}{^{210}\text{Po}}\right) / \left(\frac{^{210}\text{Po}}{^{210}\text{Po}}\right) : I_{Aa} = \int_0^{T_c} C_a \exp(-\lambda_a t) dt - C_a \cdot \exp(-\lambda_a T_c) \frac{1 - e^{-\lambda_a T_s}}{\lambda_a} \cdot \frac{1 - e^{-\lambda_a T_c}}{\lambda_a} \quad (1)$$

$$\begin{aligned} \left(\frac{^{210}\text{Po}}{^{210}\text{Po}}\right) / \left(\frac{^{210}\text{Bi}}{^{210}\text{Bi}}\right) : \\ I_{Ac} = \int_0^{T_c} \left\{ C_a \lambda_a \lambda_c \frac{\exp(-\lambda_a t)}{(\lambda_a - \lambda_a)(\lambda_c - \lambda_a)} + \frac{\exp(-\lambda_a t)}{(\lambda_a - \lambda_a)(\lambda_c - \lambda_a)} + \frac{\exp(-\lambda_c t)}{(\lambda_a - \lambda_c)(\lambda_a - \lambda_c)} \right\} dt \\ = C_a \lambda_a \lambda_c \left\{ \frac{e^{-\lambda_a T_c} (1 - e^{-\lambda_a T_s}) (1 - e^{-\lambda_c T_c})}{\lambda_a (\lambda_a - \lambda_a) (\lambda_c - \lambda_a)} + \frac{e^{-\lambda_a T_c} (1 - e^{-\lambda_a T_s}) (1 - e^{-\lambda_c T_c})}{\lambda_a (\lambda_a - \lambda_a) (\lambda_c - \lambda_a)} + \frac{e^{-\lambda_c T_c} (1 - e^{-\lambda_a T_s}) (1 - e^{-\lambda_c T_c})}{\lambda_c^2 (\lambda_a - \lambda_c) (\lambda_a - \lambda_c)} \right\} \quad (2) \end{aligned}$$

$$\begin{aligned} \left(\frac{^{210}\text{Pb}}{^{210}\text{Po}}\right) / \left(\frac{^{210}\text{Bi}}{^{210}\text{Bi}}\right) : \\ I_{Bc} = \int_0^{T_c} \left\{ C_b \lambda_c \frac{\exp(-\lambda_a t)}{(\lambda_c - \lambda_a)} + \frac{\exp(-\lambda_c t)}{(\lambda_a - \lambda_c)} \right\} dt \\ = C_b \lambda_c \left\{ \frac{e^{-\lambda_a T_c} (1 - e^{-\lambda_a T_s}) (1 - e^{-\lambda_c T_c})}{\lambda_a (\lambda_c - \lambda_a)} + \frac{e^{-\lambda_c T_c} (1 - e^{-\lambda_a T_s}) (1 - e^{-\lambda_c T_c})}{\lambda_c^2 (\lambda_a - \lambda_c)} \right\} \quad (3) \end{aligned}$$

$$\left(\frac{^{210}\text{Bi}}{^{210}\text{Po}}\right) / \left(\frac{^{210}\text{Po}}{^{210}\text{Po}}\right) : I_{Cc} = \int_0^{T_c} C_c \exp(-\lambda_c t) dt - C_c \exp(-\lambda_c T_c) \frac{(1 - e^{-\lambda_c T_s})}{\lambda_c} \cdot \frac{(1 - e^{-\lambda_c T_c})}{\lambda_c} \quad (4)$$

Where  $T_s$  : collecting period in min. (: 5 min.)

$T_c$  : elapsed time in min. (between end of sampling and start of  $n$ th counting period =  $(2 - 5 \times (1 - 1))$ )

$T_a$  : counting time in min. (: 4 min.)

$\lambda_a$  : decay constant of  $^{210}\text{Po}$  in  $\text{min}^{-1}$

$\lambda_b$  : decay constant of  $^{210}\text{Pb}$  in  $\text{min}^{-1}$

$\lambda_c$  : decay constant of  $^{210}\text{Bi}$  in  $\text{min}^{-1}$

$C_a$  : collecting rates for  $^{210}\text{Po}$  in the sampled air (dpm/min)

$C_b$  : collecting rates for  $^{210}\text{Pb}$  in the sampled air (dpm/min)

$C_c$  : collecting rates for  $^{210}\text{Bi}$  in the sampled air (dpm/min)

### 2.4 Weighted Least Squares

Assuming the respective net counts as  $N_1, M_1, M_2, M_3, M_4$  and  $M_5$  the following observation equations are obtained from equation(1)-(4)

$$\left. \begin{aligned} (4.982 \ 658 \ \zeta_a + 0.216 \ 927 \ \zeta_c) C_a + 3.697 \ 295 \ \zeta_c C_b + 15.944 \ 969 \ \zeta_c C_c &= M_1 \\ (1.599 \ 445 \ \zeta_a + 0.449 \ 527 \ \zeta_c) C_a + 5.657 \ 084 \ \zeta_c C_b + 13.372 \ 731 \ \zeta_c C_c &= M_2 \\ (0.513 \ 426 \ \zeta_a + 0.645 \ 984 \ \zeta_c) C_a + 6.990 \ 633 \ \zeta_c C_b + 11.215 \ 446 \ \zeta_c C_c &= M_3 \\ (0.164 \ 811 \ \zeta_a + 0.788 \ 983 \ \zeta_c) C_a + 7.836 \ 584 \ \zeta_c C_b + 9.406 \ 174 \ \zeta_c C_c &= M_4 \\ (0.052 \ 905 \ \zeta_a + 0.882 \ 413 \ \zeta_c) C_a + 8.306 \ 648 \ \zeta_c C_b + 7.888 \ 773 \ \zeta_c C_c &= M_5 \\ (0.016 \ 983 \ \zeta_a + 0.935 \ 117 \ \zeta_c) C_a + 8.490 \ 505 \ \zeta_c C_b + 6.616 \ 159 \ \zeta_c C_c &= M_5 \end{aligned} \right\} (5)$$

Where  $\zeta_a$  is the actual counting efficiency of the counter for  $^{210}\text{Po}$  alpha particle deposited in the filter.

The above equations (6) are indicated following the general expressions (7)

$$\left. \begin{aligned} a_1 C_A + b_1 C_B + c_1 C_C &= M_1 / \gamma_c = I_1 \\ \vdots & \\ a_i C_A + b_i C_B + c_i C_C &= M_i / \gamma_c = I_i \\ \vdots & \\ a_s C_A + b_s C_B + c_s C_C &= M_s / \gamma_c = I_s \end{aligned} \right\} \quad \text{Where: } a_i = a_{iA} \frac{\gamma_A}{\gamma_c} + a_{iC}$$

The relative standard deviation (SD) for each net counts ( $M_i$ ) is

$$SD_i = \frac{(m_i + M_{BL})}{(m_i - M_{BL})} \quad (8)$$

Where  $m_i$  is the gross counts at  $i$ -th counting period. ( $m_i - M_{BL} = M_i$ )

Since each expression of eq.(7) has different grade accuracy, it must be multiplied by the weight of  $\sqrt{P_i}$ .  $\sqrt{P_i}$  is a proportionate number of the reciprocal value of standard deviation ( $SD_i$ ).

Then the following weighted observation equations (9) are induced

$$\left. \begin{aligned} a_1 \sqrt{P_1} C_A + b_1 \sqrt{P_1} C_B + c_1 \sqrt{P_1} C_C &= \sqrt{P_1} I_1 \\ \vdots & \\ a_i \sqrt{P_i} C_A + b_i \sqrt{P_i} C_B + c_i \sqrt{P_i} C_C &= \sqrt{P_i} I_i \\ \vdots & \\ a_s \sqrt{P_s} C_A + b_s \sqrt{P_s} C_B + c_s \sqrt{P_s} C_C &= \sqrt{P_s} I_s \end{aligned} \right\} \quad (9)$$

Consequently the weighted normal equations (10) are obtained by least squares theory,

$$\left. \begin{aligned} \sum (P_i a_i^2) C_A + \sum (P_i a_i b_i) C_B + \sum (P_i a_i c_i) C_C &= \sum (P_i a_i I_i) \\ \sum (P_i a_i b_i) C_A + \sum (P_i b_i^2) C_B + \sum (P_i b_i c_i) C_C &= \sum (P_i b_i I_i) \\ \sum (P_i a_i c_i) C_A + \sum (P_i b_i c_i) C_B + \sum (P_i c_i^2) C_C &= \sum (P_i c_i I_i) \end{aligned} \right\} \quad (10)$$

The inverse matrix  $M'$  is defined against the matrix  $M$  as follows:

$$M = \begin{bmatrix} \sum (P_i a_i^2) & \sum (P_i a_i b_i) & \sum (P_i a_i c_i) \\ \sum (P_i a_i b_i) & \sum (P_i b_i^2) & \sum (P_i b_i c_i) \\ \sum (P_i a_i c_i) & \sum (P_i b_i c_i) & \sum (P_i c_i^2) \end{bmatrix}, \quad M' = \begin{bmatrix} D_{11} & D_{12} & D_{13} \\ D_{21} & D_{22} & D_{23} \\ D_{31} & D_{32} & D_{33} \end{bmatrix} \quad (11)$$

Where,  $M \times M' = E$  ( $E$  is a unit matrix.)

$$D_{12} = D_{21}, \quad D_{23} = D_{32}, \quad \text{and } D_{31} = D_{13}.$$

Therefore the  $C_A$ ,  $C_B$  and  $C_C$  is calculated by following equations (12)

$$\left. \begin{aligned} C_A &= D_{11} \sum (P_i a_i I_i) + D_{12} \sum (P_i b_i I_i) + D_{13} \sum (P_i c_i I_i) \\ C_B &= D_{21} \sum (P_i a_i I_i) + D_{22} \sum (P_i b_i I_i) + D_{23} \sum (P_i c_i I_i) \\ C_C &= D_{31} \sum (P_i a_i I_i) + D_{32} \sum (P_i b_i I_i) + D_{33} \sum (P_i c_i I_i) \end{aligned} \right\} \quad (12)$$

The concentrations of  $^{210}\text{Po}$ ,  $^{210}\text{Pb}$  and  $^{210}\text{Bi}$  are indicated as

$$A_A = C_A / v \times 2.22 \times 10^4, \quad A_B = C_B / v \times 2.22 \times 10^4, \quad A_C = C_C / v \times 2.22 \times 10^4 \times 10^3$$

where  $A_A$ ,  $A_B$  and  $A_C$ : concentration of  $^{210}\text{Po}$ ,  $^{210}\text{Pb}$  and  $^{210}\text{Bi}$  ( $\mu\text{Ci}/\text{cm}^3$ )  
 $v$  : sampling rate of the air in  $\text{l}/\text{min}$

The standard deviations of collecting rates are estimated following equations (13) under the conception of error propagation theory.

$$\left. \begin{aligned} \Delta C_A &= \left\{ \sum (P_i b_i^2 D_{11} a_i^2 + D_{12} b_i^2 + D_{13} c_i^2) \cdot I_i^2 \right\}^{1/2} \\ \Delta C_B &= \left\{ \sum (P_i D_{22} a_i^2 + D_{23} b_i^2 + D_{21} c_i^2) \cdot I_i^2 \right\}^{1/2} \\ \Delta C_C &= \left\{ \sum (P_i D_{33} a_i^2 + D_{32} b_i^2 + D_{31} c_i^2) \cdot I_i^2 \right\}^{1/2} \end{aligned} \right\} \quad (13)$$

Since the weight  $\sqrt{P_i}$  was different in each measurement, the weighted normal equation (10) and others had to be prepared and solved by use of a mini-electric computer in order to determine the radon daughters concentration and these errors.

## 2.5 Simplification Method

As the above method is complicated in calculation without a mini-computer. Apart from the method, the following technique also employed so that radon daughters concentration can be obtained by a simple calculation in the actual sampling spot.

Transforming each one of the equations (5) the following equations are induced

$$\left. \begin{aligned} (5.199 \ 59 \ C_A + 3.697 \ 29 \ C_B + 1.594 \ 50 \ C_C) &\uparrow -M_1 \\ (4.162 \ 18 \ C_A + 20.484 \ 3 \ C_B + 33.994 \ 4 \ C_C) &\uparrow -M_2 + M_1 + M_3 = M_{2+} \\ (1.887 \ 42 \ C_A + 16.797 \ 2 \ C_B + 14.504 \ 9 \ C_C) &\uparrow -M_1 + M_2 = M_{1+} \end{aligned} \right\} \quad (14)$$



Where,  $\eta_A = \eta_C = \eta$

The equations (15) are provided for solving the equations (14)

$$\left. \begin{aligned} (0.330\ 381\ M_1 - 0.234\ 923\ M_2 + 0.220\ 373\ M_{12}) X \frac{1}{\eta} &= C_A \\ (-0.004\ 156\ 03\ M_1 - 0.049\ 709\ 6M_2 + 0.121\ 070\ 1\ M_{12}) X \frac{1}{\eta} &= C_B \\ (-0.034\ 273\ 5\ M_1 + 0.088\ 134\ 0M_2 + 0.099\ 936\ 21M_{12}) X \frac{1}{\eta} &= C_C \end{aligned} \right\} (15)$$

The statistic errors  $\Delta C_A$ ,  $\Delta C_B$  and  $\Delta C_C$  of  $C_A$ ,  $C_B$  and  $C_C$  are estimated as follows :

$$\left. \begin{aligned} (0.090\ 229\ M_1 + 0.055\ 189\ M_2 + 0.048\ 564\ M_{12}) X \frac{1}{\eta} &= \Delta C_A \\ (0.000\ 017\ 3\ M_1 + 0.002\ 471\ 0\ M_2 + 0.001\ 465\ 8\ M_{12}) X \frac{1}{\eta} &= \Delta C_B \\ (0.001\ 175\ M_1 + 0.007\ 768\ M_2 + 0.009\ 987\ M_{12}) X \frac{1}{\eta} &= \Delta C_C \end{aligned} \right\} (16)$$

### 3. RESULTS OF MEASUREMENT

The typical radon daughters concentrations ( $\mu\text{Ci}/\text{cm}^3$ ) at the working places in the underground area and milling plant of the Ningyo-toge mine calculated by the proporsal methods are shown in Table 1 and 2.

Measuring points Nuclide	Underground area in Nakatsugo District			method
	working face point 1	working face point 2	working face point 3	
$^{218}\text{Po}$	$(6.58 \pm 0.48) \times 10^{-9}$	$(5.62 \pm 0.46) \times 10^{-9}$	$(8.40 \pm 0.49) \times 10^{-9}$	W.L.S.
$^{214}\text{Pb}$	$(2.81 \pm 0.13) \times 10^{-9}$	$(2.25 \pm 0.12) \times 10^{-9}$	$(2.47 \pm 0.13) \times 10^{-9}$	
$^{214}\text{Bi}$	$(2.00 \pm 0.15) \times 10^{-9}$	$(1.71 \pm 0.15) \times 10^{-9}$	$(1.89 \pm 0.15) \times 10^{-9}$	
$^{218}\text{Po}$	$(6.44 \pm 0.49) \times 10^{-9}$	$(6.05 \pm 0.50) \times 10^{-9}$	$(8.28 \pm 0.50) \times 10^{-9}$	S.C.M.
$^{214}\text{Pb}$	$(2.75 \pm 0.14) \times 10^{-9}$	$(2.42 \pm 0.15) \times 10^{-9}$	$(2.43 \pm 0.14) \times 10^{-9}$	
$^{214}\text{Bi}$	$(2.05 \pm 0.16) \times 10^{-9}$	$(1.85 \pm 0.17) \times 10^{-9}$	$(1.93 \pm 0.16) \times 10^{-9}$	

TABLE 1 Results of Measurement of Radon Daughters Concentrations and These Errors in  $\mu\text{Ci}/\text{cm}^3$  and Comparisons Between the Weighted Least Squares (W.L.S.) and the Simplified Calculation Method (S.C.M.) such as eq. (15) and (16).

Measuring points Nuclide	Milling Plant in Ningyotoge Mine			method
	working area	control room	out door of the plant	
$^{218}\text{Po}$	$(4.71 \pm 0.89) \times 10^{-9}$	$(8.02 \pm 4.26) \times 10^{-10}$	$(2.43 \pm 3.48) \times 10^{-9}$	W.L.S.
$^{214}\text{Pb}$	$(5.55 \pm 2.18) \times 10^{-10}$	$(3.02 \pm 1.15) \times 10^{-10}$	$(1.21 \pm 0.95) \times 10^{-9}$	
$^{214}\text{Bi}$	$(2.44 \pm 2.64) \times 10^{-10}$	$(0.60 \pm 1.33) \times 10^{-10}$	$(1.33 \pm 1.11) \times 10^{-9}$	
$^{218}\text{Po}$	$(4.55 \pm 0.86) \times 10^{-9}$	$(5.68 \pm 4.41) \times 10^{-10}$	$(1.75 \pm 3.68) \times 10^{-9}$	S.C.M.
$^{214}\text{Pb}$	$(4.71 \pm 2.27) \times 10^{-10}$	$(1.90 \pm 1.27) \times 10^{-10}$	$(0.77 \pm 1.05) \times 10^{-9}$	
$^{214}\text{Bi}$	$(3.02 \pm 2.64) \times 10^{-10}$	$(1.65 \pm 1.45) \times 10^{-10}$	$(1.84 \pm 1.11) \times 10^{-9}$	

TABLE 2 Results of Measurement of Radon Daughters Concentrations in the Milling Plant of Ningyotoge Mine.

RECENT TRENDS IN MONITORING RADON AND DAUGHTER  
PRODUCTS IN INDIAN URANIUM MINES

A.H. Khan and M. Raghavayya

Health Physics Division  
Bhabha Atomic Research Centre

Health Physics Unit, Jaduguda  
Jaduguda Mines, Singhbhum - 832102  
INDIA

### 1. INTRODUCTION

Monitoring programme in the Jaduguda uranium mine in India is tuned to the estimation of radon concentrations in work places. It is well known that in some countries, notably in the United States of America and in Canada, the practice is to estimate the radon daughters in working Level (WL) unit and to express the cumulative individual exposure to these contaminants in working Level Months (WLM). This has been a convenient and useful tool in the hands of the epidemiologists for correlating the incidence of lung cancer with exposure of the lungs to alpha radiation (1-4). But when it comes to translating the exposure in WLM to lung dose in rads no definite relation has so far been formulated (5-7).

In our mines in India, although we continue to use radon monitoring as the principal method of hazard evaluation, we have also in addition carried out simultaneous estimation of the WL values on many occasions. More recently some attempt has been made at determining the percentage of radon daughter activity in the unattached state obtaining in mine air.

### 2. RADON IN MINE AIR

Using the direct scintillation method which is now well known and widely adopted, radon concentration in the work places in our mines is measured on a routine basis. The data thus collected over the last 10 years has been summarised in Table 1. For this purpose the radon levels obtaining during the same operation have been averaged. The main mining operations considered are 'drilling', 'mucking (slushing)' and all others collectively as 'general'.

### 3. RADON DAUGHTERS IN MINE AIR

The radon daughters concentrations have been measured on many occasions along with radon estimations. The mean WL values during the different operations are presented in Table 2.

### 4. UNATTACHED RADON DAUGHTERS

The method adopted for estimating the percentage of unattached radon daughters was the wire screen technique (8) with the computational modification

suggested by MERCOP (9). The sampling rate was 9.5 lpm through a 59 mesh/cm prefilter and glass fibre filter combination. The collection efficiency of the prefilter for unattached radon daughters was calculated to be 0.47%. Earlier sporadic attempts had yielded very widely varying values for the unattached fractions  $f_a$  (for RaA),  $f_b$  (for RaB) and  $f_c$  (for RaC) with median values at about 6%, 3% and 1% respectively. Recent measurements however, gave considerably higher figures. All the measurements reported here were carried out just inside the adit mouth where one of the main exhaust fans is located. Hourly readings during one work shift over a period of two weeks were taken under operational (mine working) and passive (on holidays when the mining operations were suspended) conditions. For convenience we have reported only the mean values of the total unattached fraction  $f_t$  in Fig. 1.

### 5. DISCUSSION

We have adopted an  $MPC_a$  value of 250 pCi/l for a 48 hour work week in our mine on the basis of the recommendations of IAEA (10). Table 1 shows that the average radon levels in our mines have been mostly below this level. From Table 2 we can see that the WL values also have been quite low which is due to the good ventilation conditions and the consequent disruption of equilibrium between radon and its daughters. The degree of disequilibrium can be gauged from the fact that the WL to radon concentration ratio has all along been much below the theoretical value of 0.01, varying between 0.00072 in 1973 to 0.002 in 1976. Based on the WL values the mean cumulative exposure of drillers to radon daughters during the last 10 years has been  $2.19 \pm 1.11$  WL/year and the corresponding figures for the muckers (slashing crew) and remaining category of workers have been  $3.21 \pm 1.35$  WL/year and  $1.61 \pm 0.17$  WL/year respectively. These figures compare well with the current United States standard of 4 WL/year.

From Fig. 1 it may be seen that the  $f_t$  values in the exhaust air under passive conditions are higher and less varying than under operational conditions. As soon as the mining operations commence the values tend to decrease, reaching a somewhat steady state in about 8 hours. The  $f_t$  values reported here are necessarily higher than those reported by other investigators elsewhere because these measurements have been carried out at a place well removed from actual work locations.

### 6. ACKNOWLEDGEMENT

We gratefully acknowledge the constant encouragement received from Mr. S. L. Soman, Head, Health Physics Division, Bhabha Atomic Research Centre and our thanks are due to Mr. N. K. Batra, Managing Director, Uranium Corporation of India Ltd., Jaduguda for all the facilities provided for these measurements.

Year	OPERATION		
	Drilling	Mucking	General
1967	120 ± 34	230 ± 83	188 ± 56
1968	248 ± 68	178 ± 48	38 ± 29
1969	265 ± 75	358 ± 102	115 ± 39
1970	132 ± 37	103 ± 22	78 ± 27
1971	110 ± 27	110 ± 32	58 ± 8
1972	38 ± 8	72 ± 21	80 ± 20
1973	79 ± 13	74 ± 11	78 ± 21
1974	36 ± 12	168 ± 53	151 ± 52
1975	80 ± 48	70 ± 20	129 ± 40
1976	123 ± 27	96 ± 9	88 ± 9

TABLE 1 Mean radon levels (pCi/l) in Jaduguda uranium mine

Year	OPERATION		
	Drilling	Mucking	General
1967	0.17 ± 0.05	0.33 ± 0.12	0.27 ± 0.08
1968	0.36 ± 0.10	0.28 ± 0.07	0.06 ± 0.03
1969	0.38 ± 0.11	0.52 ± 0.19	0.17 ± 0.06
1970	0.19 ± 0.05	0.25 ± 0.03	0.11 ± 0.04
1971	0.16 ± 0.04	0.17 ± 0.03	0.08 ± 0.01
1972	0.06 ± 0.01	0.05 ± 0.01	0.09 ± 0.03
1973	0.06 ± 0.01	0.11 ± 0.03	0.06 ± 0.02
1974	0.14 ± 0.03	0.41 ± 0.13	0.37 ± 0.12
1975	0.21 ± 0.06	0.18 ± 0.15	0.32 ± 0.51
1976	0.59 ± 0.48	0.22 ± 0.10	0.06 ± 0.01

TABLE 2 Mean radon daughters working level (WL) in Jaduguda uranium mine

REFERENCES

- (1) WACNER, J.K., et al., Mortality patterns among U<sub>3</sub> uranium miners and millers - 1950 through 1962, Proc. IAEA Symposium on Radiological Health and Safety in Nuclear Materials Mining and Milling, 1, p - 37 (1963)
- (2) SACCO-JUNO, G., et al., Lung Cancer of uranium miners on the Colorado plateau, Health Physics, 10, p - 1195, (1964)
- (3) DONALDSON, A.W., Epidemiology of lung cancer among uranium miners, Health Physics, 16, p - 563, (1969)
- (4) LUNDIN, F.C. Jr., et al., Radon daughter exposure and respiratory cancer - qualitative and temporal aspects, "NCSH-NICHL Joint Monograph" 10003 (1971)
- (5) BALE, W.F., and SHAPIRO, J.V., Radiation dosage to lungs from radon and daughter products, Proc. UN International Conference on Peaceful Uses of Atomic Energy, 13, p - 233 (1955)
- (6) JETTERER, B., et al., Estimation of the lung tissue dose from inhalation of radon and daughters, Health Physics, 10, p - 1137, (1964)
- (7) JACOBI, W., The dose to the human respiratory tract by inhalation of short lived Th-222 and Th-220 decay products, Health Physics, 10, p - 1163, (1964)
- (8) RAJAGOPALA, M., and JONES, J.H., A wire screen filter paper combination for the measurement of fractions of unattached radon daughters in uranium mines, Health Physics, 20, p - 417, (1974)
- (9) MERCER, T.T., Unattached radon decay products in mine air, Health Physics, 28, p - 158, (1975)
- (10) IAEA, "Basic safety standards for Radiation Protection" No. 9, (1967)

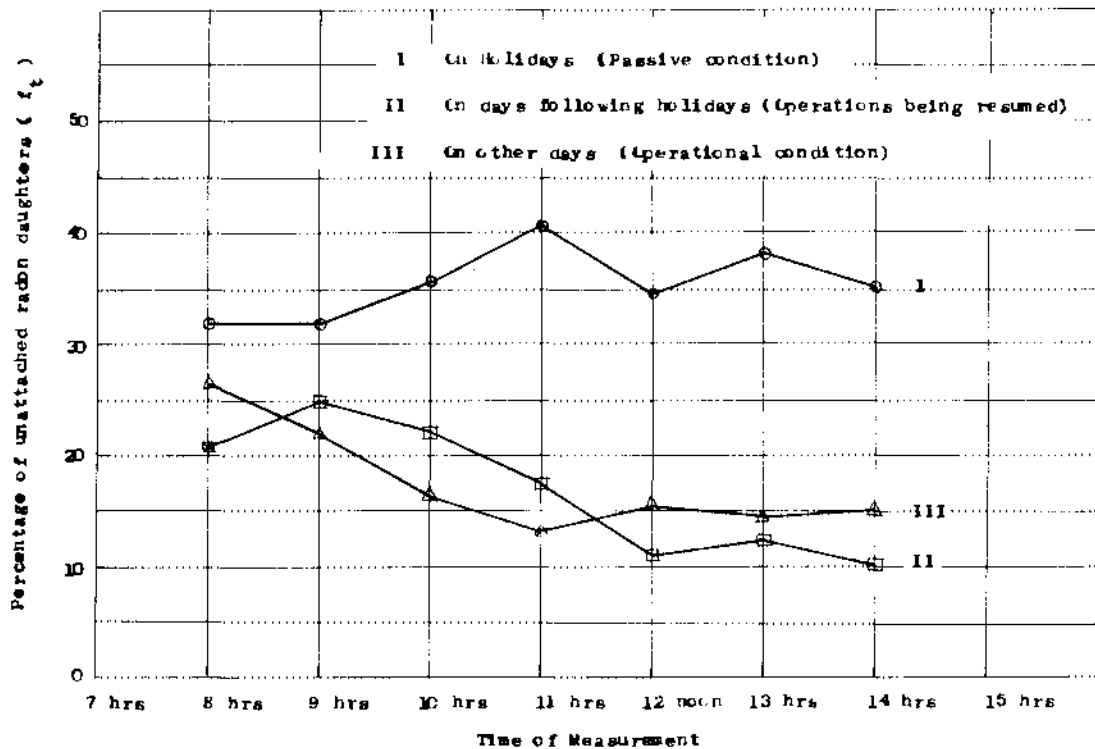

FIG. 1 Temporal variation of unattached radon daughter fractions

ENVIRONMENTAL RADIATION DOSIMETRY WITH IONIZATION CHAMBERS  
AND THERMOLUMINESCENCE DOSIMETERS

Wayne M. Lowder

Health and Safety Laboratory  
U. S. Energy Research and Development Administration  
New York, New York 10014

## 1. INTRODUCTION

Measurements of environmental radiation fields are carried out with many types of radiation detectors. Two applications of such measurements are directed toward the assessment of absorbed dose to man from externally-incident environmental radiation. First, the absorbed doses to various organs from the natural background radiation may be of direct interest on their own merits or to provide perspective in evaluating dose from other sources. This assessment requires an analysis of detector response in terms of radiation field quantities that can be related to the desired doses. Second, the assessment of organ doses from manmade sources may be desired, which requires a knowledge of detector response to the natural background radiation so that the response to the superimposed radiation may be inferred. Because of its relevance to these applications, we will consider here some of the general aspects of the dosimetric interpretation of radiation detector response to the natural background components. The methods for calibrating two widely-used detectors, the ionization chamber and the thermoluminescence dosimeter (TLD), in such radiation fields is discussed, to exemplify both the problems of analyzing detector response and the methods for arriving at reliable dose inferences. Such methods are contrasted with the recommendations of the ICRU and the areas of applicability of each are indicated.

The subject matter of this paper will be limited to the determination of absorbed dose rate or long-term dose to human organs at a particular location in the environment. The determination of dose to real individuals moving through the environment from a set of field measurements or from dosimeters worn on the body is considered in reference (1).

## 2. GENERAL METHODOLOGY OF DOSE ASSESSMENT

The general aspects of inferring dose to man from externally-incident environmental radiation have been discussed in two recent papers (1,2). The problem can be briefly described in the following manner. A radiation field within a small spatial volume is completely defined by specifying the flux density,  $\phi_i(E, \Omega)$ , as a function of energy and angle for each of the  $i$  components (particle types). In the environment, we are usually interested in the radiation field in air at some distance above the air-ground interface, often one meter. If we then introduce a mass of material, our "detector", into this volume and perhaps surround it with additional matter of the same or different composition, this modifies the flux densities within the volume, i.e.,  $\phi_i \rightarrow \phi_i'$ . Any response,  $R_i$ , of this detector to the  $i^{\text{th}}$  component can be related to these flux densities via a calibration factor,  $k_i$ , as follows:

$$R_i = \int_0^{\infty} \int_{\Omega} k_i'(E, \Omega) \phi_i'(E, \Omega) dE d\Omega \quad (1a)$$

$$= \int_0^{\infty} \int_{\Omega} k_i(E, \Omega) \phi_i(E, \Omega) dE d\Omega \quad (1b)$$

Equation 1b is more useful since it relates detector response to a quantity,  $\phi_i$ , that is independent of the presence and the properties of the particular detector. Let us now consider two such detectors, our measuring instrument and a human organ. The  $\Sigma R_i$  for the former can be a counting rate, an electric current, or another type of signal, while the  $\Sigma R_i$  of interest for the latter is mean absorbed dose over the organ mass. It is clear that the relationship between these two sets of responses is both complicated and dependent on a knowledge of each of the flux densities. Our problem is to find a method that will enable us to infer the  $\Sigma R_i$  for the human organ when we have determined the response of our measuring instrument to the incident radiation. In practice, we must usually do this without detailed knowledge of either the  $k_i$  or the  $\phi_i$ .

The key to the solution of this problem for natural environmental radiation fields is the fact that the energy and angular distributions of the flux densities of the important components, namely cosmic-ray muons and electrons and terrestrial photons, have fairly constant shapes from place to place (2). For example, Beck (3) has shown that the terrestrial photon energy spectrum at one meter above the ground is not sensitive to the relative soil concentrations of potassium, uranium, and thorium. As a consequence, the responses,  $R_i$ , of any detector are approximately proportional to the amplitudes of the total flux densities ( $= \int_0^{\infty} \int_{\Omega} \phi_i(E, \Omega) dE d\Omega$ ). They may be calibrated against these amplitudes or any other quantity proportional to them, such as ionization rate or absorbed dose rate in air (since charged particle equilibrium approximately holds in free air) or kerma or exposure rate for photons. For example, equation 1b can be modified to

$$R_i = k_i \dot{D}_i \quad (2)$$

where the absorbed dose rate,  $\dot{D}_i$ , is

$$\dot{D}_i = \int_0^{\infty} \int_{\Omega} q_i(E) \phi_i(E, \Omega) dE d\Omega = q_i \phi_i$$

with  $q_i$  being the collision stopping power for charged particles and the product of the energy and the mass energy transfer coefficient for photons.

Although many environmental radiation measurements are reported in terms of these quantities, this is but an intermediate step on the road to human dose assessment. The measurement defines the radiation field in the absence of the human body, i.e., the irradiation conditions. However, this is all the information that is needed to calculate the absorbed dose to human organs in the presence of the human body. Such calculations have been performed and reported by O'Brien and McLaughlin (4) and O'Brien and Sanna (5) for cosmic-ray particles and terrestrial photons, respectively. These data can be used to derive a calibration equation of the same form as equation (2) for each organ dose rate, to an accuracy of the order of  $\pm 10$  percent.

In the following two sections, we illustrate this methodology of calibration with two very different types of detector.

### 3. IONIZATION CHAMBER CALIBRATION

Our standard ionization chambers for environmental radiation measurements are 25-cm diameter steel spheres with walls of  $2.6 \text{ g cm}^{-2}$  thickness containing 25 atm of argon. The walls absorb any external alpha and beta radiation, and cosmic-ray neutrons lose very little energy in collisions with the argon atoms. This discrimination is useful since the terrestrial photons and cosmic-ray charged particles that produce most of the response are also the main contributors to dose to man (2).

The calibration of these chambers has been discussed in detail by DeCampo *et al.* (6). The gamma-ray response per unit flux density, exposure rate, or absorbed dose rate in free air is determined in the laboratory at various photon energies, and these data are used to infer the response to a typical spectrum of energies in the environment. The response to cosmic-ray charged particles is more difficult to determine in the absence of standard fields of known properties. Initially, we inferred the cosmic-ray response as a function of altitude by field measurements at various altitudes along with simultaneous determinations of the exposure rate by means of a gamma-ray spectrometer system (7). The inferred gamma response of the ion chamber was then subtracted from the total to yield the desired response. At later dates, we have performed theoretical analyses of the response to cosmic-ray muons and electrons (6,8) using published particle energy spectra (2,9). These yielded values for the response per unit flux density, ionization rate, or absorbed dose rate in free air in close agreement with the inferred experimental values when the sea-level ionization rate was taken to be  $2.1 \text{ ion pairs cm}^{-2} \text{ s}^{-1}$  (7).

The relation between the total instrument response to terrestrial photons and cosmic-ray charged particles and quantities such as the absorbed dose rates in free air ( $\dot{D}_t$ ) from these two components of the total field can be expressed as

$$R = R_V + R_C = k_V \dot{D}_V + k_C \dot{D}_C$$

where  $k_V$  and  $k_C$  are the calibration factors derived as described above for the two components. As it stands, this equation is inadequate to define the field with a single measurement,  $R$ , since it contains two unknowns,  $\dot{D}_V$  and  $\dot{D}_C$ . However,  $\dot{D}_C$  is known as a function of pressure-altitude to an accuracy of about  $\pm 5$  percent (7,9). Thus, a determination of barometric pressure at the time of measurement will permit the inference of  $\dot{D}_C$ , and equation 3 can then be used to infer  $\dot{D}_V$ . These two parameters can be used to obtain organ dose by applying the appropriate conversion factors from references (4) and (5).

### 4. TLD CALIBRATION

The procedure for calibrating thermoluminescence dosimeters (TLDs) in environmental radiation fields is similar to that for the ionization chambers, but involves several different problems. Both the ionization chamber and TLD responses are approximately proportional to absorbed dose in the detector medium, but the stored energy in the TLD is gradually accumulated over the time of exposure. Many of the special problems in the use of TLDs in environmental applications have been discussed by Burke (10).

Our TLD packages for environmental radiation measurement consist of five LiF (TLD-700) ribbon dosimeters ( $3.2 \times 3.2 \times 0.9 \text{ mm}$ ) mounted in a lucite



container providing at least  $0.37 \text{ g cm}^{-2}$  thickness around the ribbons. This thickness is sufficient to provide electronic equilibrium during calibration and to shield against external alpha and beta radiation. The gamma calibration is accomplished in a  $^{137}\text{Cs}$  beam in the laboratory and expressed in thermoluminescent response (integrated counts) per unit exposure. Studies of the response of such dosimeter packages as a function of photon energy and angle indicate that this calibration is also applicable (to within a few percent) to exposure in environmental photon fields.

The calibration of the response of these dosimeters to cosmic radiation is a more difficult undertaking. In late 1974, we exposed bare ribbon dosimeters to an 8 GeV muon beam of the Alternating Gradient Synchrotron at Brookhaven National Laboratory. This experiment (8) established that the thermoluminescent response per unit absorbed dose in the ribbon for such muons equals that for 0.662 MeV photons, and that simple cavity theory using restricted stopping powers yields a correct value for absorbed dose in the dosimeter. This theory was then applied at other muon energies, and the results were weighted according to the shape of the cosmic-ray muon spectrum. The net result was a calculated response to these muons per unit absorbed dose in air that is 15 percent lower than the analogous value for environmental photons. We would expect that the response to high-energy electrons in the cosmic radiation would be comparable to that for the muons. However, the theoretical considerations here are more complex, and it appears that the usual cavity theories do not yield accurate results (11). This point is of some relevance to medical dosimetry.

The gamma and cosmic radiation calibration factors obtained as described above are inserted into equation 3 to infer  $\dot{D}_v$ , the mean absorbed dose rate in air from terrestrial photons over the period of exposure. The quantity,  $\dot{D}_c$ , is determined from an estimate of the mean barometric pressure over the period of exposure. The interpretation of TLD response in terms of dose to man is identical to the interpretation of ion chamber response, once  $\dot{D}_v$  is determined:

The validity of these calibration factors has been checked by comparing four-week integrated exposure data at several field sites obtained with both our TLDs and a continuously monitoring ionization chamber. The inferred values for exposure or absorbed dose in free air from photons generally agree to within 5 percent. Another comparison between the two detectors has been made in a three-month exposure within the HASL whole body counter shield, where the bulk of the field consists of cosmic-ray muons and associated collision electrons. The ratio of the response of the TLDs to the absorbed dose in air inferred from the ionization chamber data agreed to within the uncertainties of measurement with our theoretically-derived cosmic ray calibration factor for the TLDs.

## 5. DISCUSSION

The consistency checks on our detector response calibration factors discussed above are indicative of an accuracy in our direct interpretations in terms of radiation field quantities of about  $\pm 5$  percent (s.d.). Taking account of the additional uncertainties in the analytical calculations of human organ dose and of the idealizations of the human body that are inherent in such calculations, we estimate the accuracy of the organ dose estimates to be about  $\pm 10$  percent (s.d.). It is indeed remarkable that certain regularities in the characteristics of natural environmental radiation fields permit the achievement of such a degree of accuracy in dose assessment from a single measurement or limited set of measurements.

The same considerations mentioned here for these two detectors also apply to other detectors. Studies of the energy and angle dependences of detector response to gamma radiation can usually be carried out in the laboratory, and a calibration factor derived for typical environmental photon fields (3). The evaluation of the cosmic ray response is more complicated. However, the availability of considerable information on the composition, differential flux densities, and ionization rates of the cosmic-ray components (2,9) does make possible a calculational approach to this problem when the detector geometry is relatively simple.

The effectiveness of the general methodology of dose assessment discussed here depends on the availability of information that is independent of the particular measurement process. The generation of much of this information for natural radiation fields has been carried out with this particular goal in mind. The listed references provide guidance to the sources of such information.

The application of this methodology in other radiation fields requires the generation of similar types of information so that appropriate detector calibrations can be derived. This is often the role of gamma spectrometry in the measurement of photon fields. The field-quantity-to-organ-dose conversion factors given by O'Brien and Sanna (5) are available for any photon field. Analogous calculations are in progress for charged particles.

In recent years, the ICRU (12,13) has defined a quantity called absorbed dose index at a point, which is "the maximum absorbed dose within a 30 cm diameter sphere centered at this point and consisting of material equivalent to soft tissue with a density of  $1 \text{ g cm}^{-3}$ ". This quantity, and the related dose equivalent index, is presumed "to meet the need for the characterization of ambient radiation levels at any location for purposes of radiation protection". Although the ICRU reports indicate both explicitly and implicitly that the index quantities are appropriate for radiation protection applications, these quantities might also be used uncritically for the type of dose assessment discussed in this paper. However, this approach involves measurement problems of a significant nature that have not yet been sufficiently studied, and yields only an upper-limit dose estimate that may be quite different from the actual organ doses. In the absence of any information on the ambient radiation field, the index quantity approach may be the only one available. Since this is not the case for natural environmental radiation, the approach to dose assessment via the determination of field quantities yields more realistic and more informative estimates. This is particularly important when the ultimate purpose of dose assessment is the correlation of dose with biological response.

#### ACKNOWLEDGEMENT

This paper relies strongly on the published and unpublished work of several associates in the Radiation Physics Division, notably, Harold Beck, Gail de Planque Burke and Keran O'Brien, and on the support of James McLaughlin.

#### REFERENCES

- (1) LOWDER, W. M., Methods of external radiation dose assessment, An. Acad. Bras. Cienc. (to be published, 1977)
- (2) LOWDER, W. M., Basic aspects of environmental radiation measurements, Proc. Tenth Midyear Symp., Health Phys. Soc., Saratoga Springs, NY (1976)
- (3) BECK, H. L. "The physics of environmental gamma radiation fields", The Natural Radiation Environment II (ADAMS, J. A. S., LOWDER, W. M., GESELL, T. F., Eds), USERDA Report CONF-720805-P1 (1972) 101
- (4) O'BRIEN, K., McLAUGHLIN, J. E., The radiation dose to man from galactic cosmic rays, Health Physics 22 (1972) 225
- (5) O'BRIEN, K., SANNA, R. S., The distribution of absorbed dose rates in humans from exposure to environmental gamma rays, Health Physics 30 (1976) 71
- (6) DeCAMPO, J. A., BECK, H. L., RAFT, P. D., "High pressure argon ionization chamber system for the measurement of environmental exposure rates", USAEC Report HASL-260 (1972)
- (7) LOWDER, W. M., BECK, H. L., Cosmic-ray ionization in the lower atmosphere, J. Geophys. Res. 71 (1966) 4661
- (8) LOWDER, W. M., BURKE, G. de P. "The cosmic ray response of LiF TL dosimeters", USERDA Report HASL-313 (to be published, 1977)
- (9) NCRP "Natural background radiation in the United States", NCRP Report 45, Washington, DC (1976)
- (10) BURKE, G. de P., Thermoluminescence dosimetry: environmental monitoring near nuclear reactor sites, IEEE Trans. Nucl. Sci. NS-23 (1976) 1224
- (11) O'BRIEN, K., Monte-Carlo calculations of the energy response of lithium fluoride dosimeters to high-energy electrons (< 30 MeV), Phys. Med. Biol. (to be published, 1977)
- (12) ICRU "Radiation quantities and units", ICRU Report 19, Washington, DC (1971)
- (13) ICRU "Conceptual basis for the determination of dose equivalent", ICRU Report 25, Washington, DC (1976)

## THE SURVEYING OF RADIATION ENVIRONMENTS

J. R. Harvey

Central Electricity Generating Board, Berkeley Nuclear Laboratories,  
Berkeley, Gloucestershire, UK.

## ABSTRACT

A number of conceptual frameworks have been suggested for relating the results of an environmental survey to personal dose. Environmental parameters such as exposure, MADE and dose index have been defined by international committees, others such as maximum permissible fluence and dose ceiling have been suggested in the open literature. These approaches can be shown to fall into two groups. In one group the survey parameters are additive, accurately measurable, but not directly related to peak dose equivalent in the body, whereas in the other they are neither measurable nor additive but are directly related to peak dose equivalent. The advantages and disadvantages of the two approaches are discussed and contrasted. In application to a specific radiation environment it can be shown that one type of approach can (and frequently does in practice) lead to significant over-estimation of personal dose.

## 1. THE RELATIONSHIP BETWEEN THE READINGS OF SURVEY METERS AND PERSONAL DOSEMETERS

Instruments used to survey environments containing gamma, X and neutron radiation are based on the following principles:

The neutron instrument is required to register peak dose equivalent in the body when radiation is unidirectional and monoenergetic. The reading of a gamma or X-ray sensitive instrument also corresponds roughly to peak dose in the body when the radiation is unidirectional since in this case exposure or absorbed dose in air is closely related to peak dose in tissue.

The instrument designer generally strives to attain isotropic sensitivity for a variety of reasons including the unavoidable practical consideration that he cannot duplicate the mass of shielding in the human body within a portable instrument. The shielding afforded by the operator's body is only slight because an average body subtends only 1.5 steradians when the instrument is held 30 cm away and therefore blocks out only 12% of the radiation in an isotropic environment.

The personal dosimeter is also designed to record peak dose equivalent in tissues adjacent to its location on the body. The device, however, when located close to the body is far from isotropically sensitive because it is heavily shielded from radiation incident for the rear hemisphere.

The personal dosimeter and the survey instrument will therefore only give the same reading when the radiation is incident from one direction and when the direction is normal to the part of the body on which the personal dosimeter is located. In practice, radiation environments are far from unidirectional and individuals rarely stationary! In many environments associated with nuclear power, for example, the radiation incidence is more nearly isotropic than unidirectional. In any event the basic philosophy of radiation measurements should be able to take account of all possible radiation environments ranging from unidirectional to isotropic.

The relationships between the readings of the "perfect" survey meter and the "perfect" personal dosimeter for two notional isotropic radiation environments are given in Table 1.

	Response of "perfect" survey meter /mrem hr <sup>-1</sup>	Reading of "perfect" personal dosimeter /mrem hr <sup>-1</sup>
1 MeV neutrons	100	32
660 keV photons	100	83
Total	200	115
10 keV neutrons	100	29
50 keV photons	100	55
Total	200	84

Data extracted from Table 1 (1) which is based on computer calculations of dose in phantoms.

TABLE 1 Isotropic radiation environments

It can be seen that the readings differ by factors around two. In environments chosen to maximise the difference, the factor can be as large as six (1,2); again for isotropically incident radiation.

It is clear that the two devices measure completely different quantities. In the terminology of ICRU 25 (3), the survey meter measures a "receptor free" quantity, the personal dosimeter a "receptor" quantity. The "receptor" is, of course, the human body.

## 2, THE ADVANTAGES OF USING COMPLEMENTARY QUANTITIES

There is a great deal to be gained by defining a system in which different quantities are used for personal dosimetry and environmental survey. If such an approach is not followed and it is assumed that both types of detector measure the same quantity, then internal discrepancies of factors as large as six are unavoidable. This will lead to misunderstandings and to a general lack of rigour, particularly in situations where doses are required to be measured with high accuracy. It can lead, for example, to unnecessary over-estimation of personal doses as frequently happens at the present time when personal neutron dosimetry systems are calibrated on the basis of survey meter readings taken in working environments where radiation is far from unidirectional.

Receptor free field quantities are not only accurately measurable but are also additive, so that the value of such a quantity in a composite field is equal to the sum of the quantities associated with the component fields. All field quantities, such as electric and magnetic fields, exposure, fluence, etc., are additive and, in fact, the international standard on quantities, units and symbols (4) requires that quantities should be additive (paragraph B2.1). Although no receptor field quantity can be additive, doses measured at a specific depth at a given location on a phantom as measured by personal dosimeters are additive.

Radiation quantities which have been described in the literature can be divided into "receptor" and "receptor free" quantities as in Table 2.

Receptor present	Receptor absent
Dose Equivalent Indices ICRU Reports 19 and 25 (5), (3).	Dose Equivalent Ceiling (1) Harvey, 1975.
MADE (Maximum Dose Equivalent) ICRU Report 20, (6)	Exposure
	Dose in air, free in air.
Dose equivalent at specific depths in a phantom, e.g. CEC, 1975. (7) White, 1974. (8)	Maximum Permissible Fluence Burlin and Wheatley, 1971 (9)

TABLE 2 Possible Radiation Parameters

A discussion of the advantages and disadvantages of the various parameters is outside the scope of this paper which merely attempts to make the point that two complementary quantities are required for a self-consistent and rational approach to the specification of radiation environments. Two appropriately complementary quantities for example would be "dose equivalent ceiling" and an analagous, additive receptor quantity. Alternatively, a receptor-free analogue of any given receptor quantity could easily be specified.

The important point is that in many radiation environments, the system of quantities should not be such as to encourage the use of field parameters for estimating the dose rate in a person's body. The field measurement should be used to define an upper limit on dose rate and hence an exposure period during which a given dose cannot be exceeded. The dose to specific parts of the body of the exposed individual can then be assessed accurately by the use of personal dosimeters. Such a system of quantities would therefore encourage precision and rigour in health physics measurements and clearly identify the central role of the personal dosimeter and the complementary role of the survey instrument.

#### REFERENCES

- (1) HARVEY, J.R. Phys. Med. Biol. 20, 6, 1003-1014 (1975).
- (2) DUNSTER, H.J. "Quantities to be measured and the necessity for records" Radiation Protection, Philosophy and Implementation. EUR 5397e.
- (3) ICRU. Conceptual Basis for the determination of dose equivalent. Report 25, ICRU (1976).
- (4) ISO. International standard on the general principles concerning quantities, units and symbols. ISO 31/0-1974E (1974).
- (5) ICRU. Radiation Quantities and Units. Report 19. ICRU (1971).
- (6) ICRU. Radiation protection instrumentation and its application. Report 20, ICRU (1971).

- (7) CEC. Commission of the European Communities. Technical recommendations for monitoring the exposure of individuals to external radiation. EUR 5287e (1975)
- (8) WHITE, D.F. The relationship between instrument calibration and the interpretation of measurements in radiation protection monitoring. UK National Radiological Protection Board, NRPB-M17 (1974)
- (9) BURLIN, T.E., WHEATLEY, B.M. Phys. Med. Biol. 16, 47-56 (1971).

ACKNOWLEDGEMENT This paper is published by permission of the Central Electricity Generating Board.

PHYSICAL QUANTITIES FOR INDIVIDUAL AND AREA MONITORING, AND  
THEIR ROLE IN RADIATION PROTECTION REGULATIONS

Siegfried R. Wagner

Physikalisch-Technische Bundesanstalt  
Bundesallee 100, D-3300 Braunschweig  
Federal Republic of Germany

## 1. THE CONCEPTUAL BACKGROUND

No doubt, the success of radiation protection provisions largely depends on objective, reliable and sufficiently accurate measurements. Hence measurements of anticipatory and monitoring character have been performed since the early days of radiology and have gained rapidly increasing importance with the advent of the nuclear age. But it was usually not so clear what was measured, i. e. what physical quantity, the procedure of measurements being sufficiently well defined nevertheless. This very unique situation in an exact science like radiation physics manifested itself in the curiosity that the Röntgen was a well defined and since 1928 also internationally adopted unit /1/; but not till 1962 the physical quantity it belonged to was defined by ICRU /2/, namely exposure. This conceptual vagueness persisted insofar as it remained a contested question, whether exposure should be considered as (a) a dose quantity, i. e. a quantity describing the result of the interaction of radiation with matter (air) /3,4/, namely something like a specific ionisation; or (b) a radiation field quantity /5/. The situation gained conceptual improvement by the definition of the quantity absorbed dose in 1953 /6/, but simultaneously, the easy measurability was lost. As long as only photon and electron radiations were involved, the quantities absorbed dose and exposure provided a sufficiently safe basis for judging radiation risks and radiation effects. This was no longer the case with the increasing occurrence and application of high LET-radiations and the potential hazards caused by radioactive intakes. To keep up with these complications without having to abandon a uniform dose limit considered to be acceptable in radiation protection surveillance, the quantity dose equivalent was at last defined 1962 in its present form /7/. According to ref. /8,9/ dose equivalent is a weighted absorbed dose, weighted with dimensionless factors allowing for influences of radiation quality (LET) (quality factor Q) and other reasons for modification (e.g. peculiarity of distribution of radioactive substances in the body). These factors are the ratios of the absorbed doses of e.g. the high LET radiation to the absorbed dose of low LET radiation, both absorbed doses considered to be equivalent regarding their potential hazard in the frame of administrative radiation protection regulations.

## 2. SPECIFICATIONS OF DOSE EQUIVALENT

But as with absorbed dose, dose equivalent is a general quantity which needs further specification in order to have a unequivocal meaning. In particular, this concerns the kind of matter in which it is to be determined, the geometry, and the structure of the irradiated object, and the site in which it is to be determined within this object. It is in this quantity that the permissible dose limits are given by ICRP /10/, i. e. in terms of mean dose equivalents averaged over certain so-called critical organs. However, this quantity cannot be determined in a routine radiation protection programme and luckily, there is no need to do so, except in the



rare cases of gross accidental overexposures where the possibility of radiation injuries must be considered (cf. No. 91 of ref. /11/).

Notwithstanding, there is a gap between radiation protection regulations and the practice of radiation protection surveillance. Official regulations sometimes state maximum permissible dose equivalents without giving the necessary specifications of this quantity. But as the numerical values of these limiting dose equivalents can be traced back to the ICRP-Recommendations, they are average values in the relevant critical organs. In contrast, the results of radiation monitoring are often still stated in terms of exposure, at least in the frequent case of area or individual monitoring for photon radiation, and compared to the dose equivalent limits using an approximate conversion to some dose equivalent quantity. A different approach was used in area monitoring for neutrons. Instruments here are mostly calibrated to indicate maximum dose equivalent in a standardized phantom; or measured neutron fluences are converted to that quantity using the results of calculations.

### 3. THE DOSE EQUIVALENT INDEX CONCEPT

Regarding conceptual clarity, the situation is really very unsatisfactory. Taking into account that the need for an accurate determination of organ doses does not arise in routine surveillance, considering furthermore the complexity of such determinations and the practical impossibility to perform them on the base of the results obtained from a routine individual or area monitoring programme, but aiming at a general dose limit as mentioned above, there arises the need of defining a standardized quantity which is of the kind of dose equivalent. On the one hand this should avoid some of the geometrical and structural involvement of the human body, on the other hand it should be more closely related to the results of radiation monitoring. The quantity dose equivalent index as introduced by ICRU /8,9,12/, largely fulfils these requirements. The phantom is a sphere of 30 cm diameter of given atomic composition and density. This phantom is sufficiently anthropomorphic for radiation protection purposes, and there is no problem of its orientation in the radiation field. It then would be reasonable to state so called derived limits for external irradiation in radiation protection regulations in this quantity, which is applicable to all kinds of radiation.

As the dose equivalent index is defined as the maximum dose equivalent in the sphere mentioned above (the special case of mixed radiations of short and long range is treated in ref. /12/) it does not lend itself easily to measurement, but it has the advantage of being so clearly defined that measuring devices can be constructed, which allow a determination to a sufficiently close and calculable approximation; and that suitable calibration procedures can be devised.

In order to do so, the relation between the dose equivalent index and the quantities used until now, as exposure, absorbed dose in air, and particle flux density, the units of which are realized and distributed by the National Laboratories, must be investigated by calculation and experiment. Of course, these relations will depend on incident radiation energy and directional distribution. Calculations of this kind are being performed at Neunerberg (Gesellschaft für Strahlen- und Umweltforschung).

#### 4. DISCUSSION OF POSSIBLE OBJECTIONS

A possible objection against the use of the concept of dose equivalent index as advocated here, is that instruments would be bulky and hence not suited for use in radiation fields with strong gradients. But there really is no need for bulky instruments except perhaps for neutron radiation where dose build up heavily depends on the size of the irradiated body, as only the response of the instrument is required to be proportional to the dose equivalent index, and its physical size is not required to be the 30 cm diameter sphere. This means that the energy dependence of instruments and the calibration procedures must be devised expediently. Another objection could be that the index quantities by definition always refer to the center of the sphere and hence are not defined for smaller distances than 15 cm from the surface of a radiating object. Some transport regulations for radioactive sources prescribe however, that certain limits of dose equivalent rates not be exceeded at shorter distances or even at the surface of packages. But it would then be reasonable to change these regulations, as the center of a person probably cannot move closer to that surface than the center of the sphere. It should be kept in mind however, that the dose equivalent maximum within the sphere is usually not at great depth, so much the more in very inhomogenous radiation fields. Therefore, the detector of instruments designed for such situations must also be small, so they can be moved to short distances from the radiating surface, irrespective of the fact that the reading relates to the point of nearest approach of the hypothetical 30 cm sphere.

As for the introducing of the dose equivalent index concept as the basis of area and eventually individual radiation monitoring, an international discussion has just begun (e.g. in IEC Technical Committee 45 B). In the Federal Republic of Germany, however, there is some realistic expectation that it will be introduced in radiation protection practice quite soon via a new German Standard (DIN).

#### REFERENCES

- /1/ II<sup>nd</sup> International Congress of Radiology, Stockholm 1928.
- /2/ International Commission on Radiological Units and Measurements (ICRU), Report 10a: Radiation Quantities and Units, NBS Handbook 84, Washington 1962.
- /3/ H. Fränz: Physikalische Begriffe und Größen in der Dosimetrie ionisierender Strahlen. *Strahlentherapie* 131 (1966) 270.
- /4/ S. Wagner: Radiation field quantities or dose quantities in radiation protection, *ATKE* 25 (1975) 303.
- /5/ I.E. Burlic and B.M. Wheatley: A Unified Approach to Dosimetry Problems in Radiological Protection. *Phys.Med.Biol.* 16 (1971) 47.
- /6/ VII<sup>th</sup> International Congress of Radiology, Copenhagen 1953.
- /7/ Radiation Quantities and Units. International Commission on Radiological Units and Measurements, Report 10a, NBS Handbook 84, Washington 1962.
- /8/ Radiation Quantities and Units. ICRU Report 19. International Commission on Radiation Units and Measurements, Washington 1971.

- /9/ Dose Equivalent. Supplement to ICRU Report 19. International Commission on Radiation Units and Measurements, Washington 1973.
- /10/ Recommendations of the International Commission on Radiological Protection (Adopted September 10, 1965). ICRP Publication No. 9, Pergamon Press 1966.
- /11/ General Principles of Monitoring for Radiation Protection of Workers. ICRP Publication No. 12, Pergamon Press 1969.
- /12/ The Conceptual Basis for the Determination of Dose Equivalent. ICRU Report 25. International Commission on Radiation Units and Measurements, Washington 1976.

## REALIZATION OF DOSE MEASUREMENT IN RADIATION PROTECTION

by Herbert Reich

Physikalisch-Technische Bundesanstalt,  
D-3300 Braunschweig, Federal Republic of Germany

**SUMMARY** The dose quantities (a) to be realized by primary standards and (b) to be assessed by radiation protection instruments are discussed. For photons up to one MeV the "exposure" will retain its prominent position only with regard to primary standards, for radiation protection field instruments the ICRU-concept of "dose equivalent index" appears to be better suited. It may be approximated by measuring dose equivalents in two different depths. The design features of an instrument are outlined.

## 1. INTRODUCTION

Each instrument intended to be used for quantitative measurements requires calibration, and for this purpose an exact assessment of the quantity to be measured. Up to now it has been an unwritten rule that the national laboratories, using primary standards, had to determine the units of those quantities which had to be recorded by field instruments. Through the calibration chain the quantities remained unchanged.

Dosimetry was no exception to this rule for 50 years; the quantity exposure with its unit, the roentgen, played the dominant role. This has now changed. The exposure does not meet the present demands on account of the restricted energy region and the special reference medium air, and in regard of its restriction to indirectly ionizing radiation. In radiation protection it is necessary to distinguish between three types of dose quantities: 1) The definition quantity designed to give a relationship to the quantity to be determined, the dose to the body and its organs. The definition quantity needs not necessarily be easily measurable, but it shall be "safe" (without exaggeration), simple, logical, unique and applicable to all kinds of radiation. 2) The quantity for primary standards, which shall be easily reproducible in standard laboratories all over the world, in particular as regards materials and geometrical parameters. 3) The special purpose quantity for application to dosimeters in the field, which may contain further simplifications and restrictions but fulfils certain requirements for estimating the doses produced in exposed workers. As a consequence of this differentiation, universally approved conversion factors have to be determined in order to guarantee the international comparability of measurements.

In the previous paper (Wagner) it was shown, that a definition quantity which satisfies practical requirements is the dose equivalent index,  $H_T$ , of the ICRU. The present paper discusses the two other quantities and their realization for photon and electron radiation.

## 2. DOSE QUANTITIES FOR PRIMARY STANDARDS

There is no difference of opinion among specialists that for photons

up to about 1.3 MeV for primary standards the most expedient quantity at present is still the exposure X. The corresponding unit is determined by measurements in air under conditions of secondary electron equilibrium: at low energies using parallel plate chambers, above 400 keV using small ionization chambers with air equivalent walls. The exposure is defined by only a small number of geometrical parameters and of material dependent data. Any other quantity referring to a phantom would require specification of the source-detector distance, the depth in the phantom, the field size and the phantom material.

The quantity exposure was considered so important by the German Standards Committee that it gave its pendant in terms of absorbed dose, the quantity  $D_S = (\bar{W}/e)X$ , the special name "Standard-Energiedosis". ( $\bar{W}/e$ , the mean energy for producing an ion pair in air divided by the elementary charge, can be regarded constant independent of energy above 5 keV.) The need to introduce  $D_S$  was realized in connection with the introduction of SI units in radiology.

For photon energies between 1 and 50 MeV, for  $\beta$ -rays and high energy electrons primary standards of different kinds were developed, which gave more direct access to the absorbed dose in a phantom than the methods for determining the exposure. These are "ionization chambers fulfilling the Bragg-Gray conditions", calorimeters and chemical dosimeters.

### 3. THE SPECIAL PURPOSE DOSE QUANTITIES FOR FIELD INSTRUMENTS

The dose equivalent index cannot be determined for all radiation types and energies by a single instrument, one needs to find a solution which takes the demands of radiation protection into account. In the publication no. 9 /1/, the ICRP recommends a maximum permissible dose for the skin, which is six times higher than that for the whole body or the bone marrow. Therefore several international bodies considered it necessary and sufficient to measure the dose equivalents  $H_1$  and  $H_2$  at two different depths, which may be simulated by filters in front of two detectors. Since the basal cells of the skin lie at a depth (expressed as mass divided by area) of 5 to 10 mg cm<sup>-2</sup>, the filter thickness of the first detector measuring  $H_1$  should have a value within this range, according to recommendations of the CEC /2/. For the second detector, which indicates the depth dose  $H_2$ , a filter thickness of order 400 to 1000 mg cm<sup>-2</sup> is recommended.

A study carried out by Jacobi, Kossel and Reich /3/ shows that the interpretation of the results at these two depths covers all information which is necessary in routine radiation protection surveillance. One can assume that - except for rare cases which can be estimated - the individual dose measured near the surface of the body is greater than the mean dose in the deeper lying organs. Hence, the individual dose  $H_1$  measured with low filtration (5 to 10 mg cm<sup>-2</sup>) can be set equal to the skin dose; and that with strong filtration,  $H_2$  (400 to 1000 mg cm<sup>-2</sup>), can be taken as the so called whole body dose.

Different significance was given to the method of measuring  $H_1$  and  $H_2$  by the German Standards Committee on radiology. It interpreted the two quantities as an approximation not for certain organ doses, but for  $H_1$  as the definition quantity and the base for establishing the connection to organ doses. The idea is to support the development of

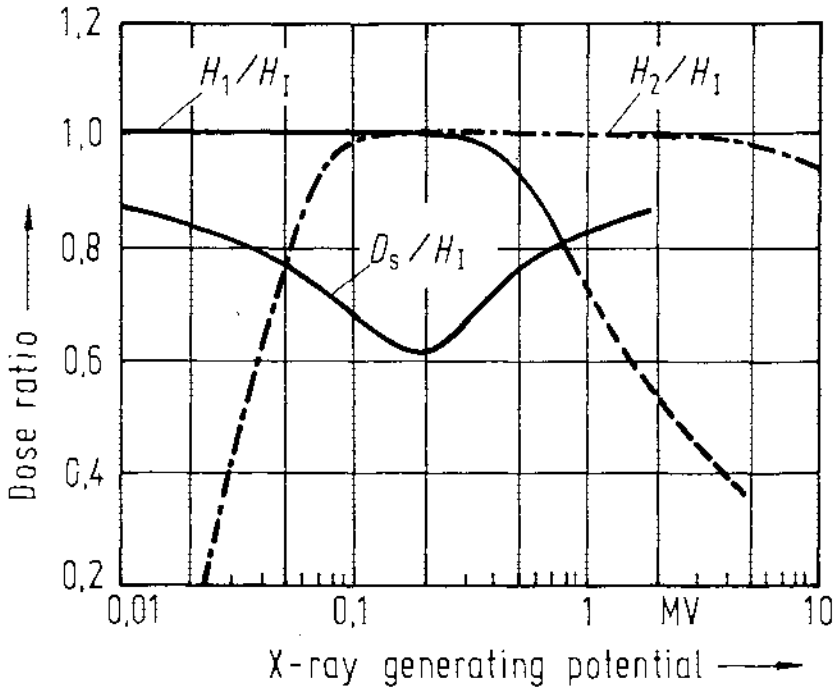

Figure 1. Radiation quality dependence of the ratios  $H_1/H_I$ ,  $H_2/H_I$ , and  $D_s$  (air)/ $H_I$  for so called "normal radiation" (cf. Wachsmann and Drexler, /4/)

an universal practice of calculation and calibration. Figure 1 gives an impression of how the ratio of the different dose quantities to the dose equivalent index  $H_I$  depends on radiation quality. Here  $H_1$  and  $H_2$  are assumed to refer to the depths  $7 \text{ mg cm}^{-2}$  and  $1000 \text{ mg cm}^{-2}$  respectively in the ICRU-sphere. The incident radiation is assumed to be uniform in a broad parallel beam. The curves represent an estimate derived from data of the literature. By definition  $H_I$  is always the maximum, all ratios in fig. 1 can only be less than 1. It can be seen, that the surface dose equivalent  $H_1$  gives a good approximation for  $H_I$  up to about 0.4 MV, whilst  $H_2$  delivers good results between 0.1 and 10 MV. The fall-off on the left of the  $H_2/H_I$ -curve reflects the photon absorption in the thicker front layer at low energies. Indeed,  $H_1$  and  $H_2$  cover practically all cases encountered in radiation protection. In most cases only one quantity - eventually one lying in-between  $H_1$  and  $H_2$  - will suffice for routine surveillance.

The  $D_s/H_I$ -curve related to the exposure shows a strong dip between 0.1 and 0.2 MV, which reflects the absence of back scattering in free air compared with the surface dose equivalent  $H_1$ . This means: exposure meters in free air (in a unidirectional radiation field) undervalue the skin dose for persons in this location. If, on the other

hand, the response of the instrument is directionally independent and the radiation is incident from many sides, then appreciable overvaluation compared with  $H_I$  may result. Both the under as well as the overvaluation of the dose, compared with the definition quantity, make the quantity  $D_S$  not very suitable for radiation protection purposes.

An instrument which comes nearest to measuring  $H_I$  would have a thin entrance window and thick side and back walls. In free air it would have to be turned to find the maximum. It would indicate the skin dose  $H_1$  and, with an additional filter, the depth dose  $H_2$ . The response of this kind of instrument would not depend on whether it is placed in free air or at the surface of a phantom. Personal dosimeters which are worn on the trunk may be thin walled to all sides and be calibrated in terms of  $H_1$  at the surface of a phantom.

#### 4. CONCLUDING REMARK

The dose equivalent index of the ICRU, approximated for photon and electron radiation by the dose equivalents at two different depths (5 to 10  $mg\ cm^{-2}$  and 400 to 1000  $mg\ cm^{-2}$ ) proves to be a suitable concept for radiation protection purposes. It yields a better approximation to the quantities needed for assessing individual doses than the exposure used hitherto. In normal practical cases the dose values obtained can be expected to be higher than the mean dose to deeper lying organs of a body (provided the measurement is correct), but excessive overvaluation in multidirectional radiation fields is avoided.

#### REFERENCES

- /1/ International Commission on Radiological Protection  
ICRP-Publication 9, Pergamon Press 1966
- /2/ Commission of the European Communities: Radiological Protection,  
Technical Recommendations for Monitoring the Exposure of Individuals to External Radiation, EUR 5287 e, 1975
- /3/ W. Jacobi, F. Kossel und H. Reich, Generelle Perspektiven der  
Personendosisüberwachung in der Bundesrepublik Deutschland,  
STH-Bericht 7/76, Bundesgesundheitsamt, D-8042 Neuherberg, 1976
- /4/ F. Wachsman, G. Drexler, Graphs and Tables for Use in Radiology,  
Berlin, 1976

A PROPOSAL TO I R P A FOR A SOLUTION OF THE PROBLEM OF THE S I - UNITS  
IN RADIATION PROTECTION AND RADIOLOGY

H. Brunner

Secretary, Fachverband für Strahlenschutz  
c/o Health Physics Division, EIR  
CH-5303 Wuerenlingen, Switzerland

### 1. INTRODUCTION

In order to be ready for the centennial of the International Metric Convention the decisions about the introduction of the SI units have been hurriedly pushed through by a small group of metrologists without sufficient consultation and participation of practitioners and industry.

This is especially true and grave for the radiological units (Ci, R, rad, rem) where neither IRPA nor medical societies or their members had a fair chance to make comprehensive studies, proposals or statements in due time. Fortunately most countries which now try to introduce the recommendations into national legislations have been forced to recognize and reconsider the problems of the radiological units.

IRPA and its Associate Societies are urged to take advantage of this new situation and to act immediately in order to work out reasonable and practicable proposals.

### 2. THE PRESENT SITUATION

The bodies responsible for the SI units have very lately tried to correct at least a few of the worst drawbacks of the original puristic proposal by admitting the special names Gray for the unit of absorbed dose and Becquerel for the unit of activity. Countries which have tried to adopt the SI system have either given the "old" radiological units a special status allowing their future use side by side with the new SI units or have been forced by the arguments from health physicists, radiologists and industry to introduce a moratorium or provisional transition period of five to ten years in waiting for further international development. Even in the most recent publications of national or international bodies and in technical or scientific publications either the old units are still used exclusively or at worst side by side with the new ones; nobody dares to use the new units alone.

### 3. A SHORT REVIEW OF PROBLEMS AND ARGUMENTS

For practical application there is no obvious or recognizable need for other than the old radiological units.

One may not argue in the same way as for the change from non-metric anglo-saxon units to the metric system. Contrarily to that case the SI units in radiation protection cannot bring simplification of calculations or improved international standardization because we already have this with the old units. All we have to expect are practical complications, errors, confusion and additional calculations. There will be no simplification of calculation by using SI units because already the old units are decimal ones while the non-decimal time units for half life or duration of measurements or exposures will remain. Changed conversion factors and the loss of a familiarity of long years with the orders of magnitude will bring further complications.



The orders of magnitude of practicable units should provide simple figures for the mostly used values. This is even recognized in the SI system, e.g. by admitting the bar =  $10^5$  Pa. Only in radiation protection we would be forced to use extremely unhandy orders of magnitude. The average citizen is able to understand prefixes between milli- and kilo-, technicians between micro- and Mega-, anything outside this range is even difficult for scientists, and everybody will have to look up such new ones as atto-, Peta- or Exa-.

Even in the SI system practical and proven "old" units have been preserved in various fields, such as kWh, eV, atomic mass unit, sea mile, knot, carat, tex, liter, are, minute, hours, decibel etc. Many of these units need much more troublesome descriptions by SI units than Ci, R, rad or rem. Thus there is no real argument against using old and new radiological units side by side, and the prejudice has been set for other applications and units. Why should radiation protection and radiology be discriminated compared with navigation or jewellery ?

An additional reason not to hurry with a decision about units is the fact that there are yet unsolved problems of radiological quantities such as a replacement of exposure or a more generally applicable similar quantity, or questions about dose equivalent and index quantities. These should be settled before the units can be dealt with in a coordinated way.

A large part of the efforts for better training and information of workers and of the public and for giving them at least an idea of the orders of magnitude of radiation exposures would be seriously impaired or even annihilated by switching to completely unfamiliar units and magnitudes. We will face serious accusations of falsification or cheating if we express environmental releases in Giga-Bq instead of mCi per year or reduce the dose values by a factor of 100 through the use of the Gy. That this may have uncontrollable political, psychological and economical effects in today's unstable situation regarding nuclear power and waste disposal should be quite clear even to scientists in the ivory tower.

Thus the whole question is no longer a purely scientific problem but has important practical and even political consequences. We must not forget that in radiation applications and protection today more than 90% of the work is done not by scientists but by technicians and workers with only limited radiation protection training.

Discussions at the Washington and Amsterdam IRPA congresses, at a NEA/ICRP seminar, in the Fachverband für Strahlenschutz and, as an excellent example, the "Andersen fairy tale" by J.W.Poston in the October 76 issue of "Health Physics" showed clearly the large opposition of the practical health physicists against a change (there is an even larger "silent majority"). In Switzerland the Federal Commission for Radiation Protection stated very clearly and categorically that the old radiological units should be kept together with the new SI units.

Can we really risk a radical change for the only sake of aesthetics and physical purism ?

Did any of the bodies recommending the SI units ever do a risk-benefit-cost analysis ?

#### 4. SOME ELEMENTS OF A RISK-BENEFIT-COST ANALYSIS

We are urged by ICRP to do an analysis of the necessity and of the risks, benefits and costs of any radiation exposure. If we want to remain credible, it is compulsory that we do the same thing if we want to introduce new quantities or units in radiation protection. Space does not allow to present a complete analysis, so only a few of the factors which would have to be analyzed in order to reach an acceptable decision shall be enumerated:

##### Risks:

- High probability of frequent and grave errors by many orders of magnitude in radiation protection, radiology and radiotherapy with real risks for life and health (this is a significant difference for radiological units compared with many other units).
- Political, psychological and economical risks due to public reactions with consequences for decisions on nuclear power and waste disposal. These risks are so serious in the present situation that no scientists may forget about these practical aspects in favour of purely scientific arguments.

##### Benefits, Needs:

- No real benefit for radiation protection or radiology has been shown.
- No real need for a change has ever been expressed by practitioners.

##### Costs:

The proposed short-transition times of five to ten years without sufficient time for testing and introduction of new units would provoke a huge amount of completely unnecessary costs such as:

- Scrapping and replacement or conversion of measuring instruments that still work satisfactorily and could remain in service many more years; additional costs for recalibration (even the standardizing laboratories would be flooded by calibration requests and might be unable to handle those in due time).
- High costs for industry for design and production of new instruments within a very short time, resulting in unnecessarily high investments for exaggerated production capacities which would be used only a short time, and consequently resulting in increased costs for the buyers without an additional benefit in terms of performance.
- Large expenditures in many years and money for:
  - training and instruction,
  - recalculation of limits, working levels and similar complications,
  - amendment and replacement of laws, regulations, codes, standards, recommendations, textbooks, forms, manuals, handbooks etc., without the cheaper possibility to wait for other and sufficient reasons for a replacement or amendment,
  - costs of all errors and their consequences which will happen during many years due to the forced introduction of unfamiliar units and unhandy orders of magnitude.

Summing up the probable results of an analysis of the needs, risks, benefits and costs we find:

- no real or urgent needs
- no real benefits
- plenty of real risks and hazards
- many complications for practical application
- unnecessary and very high costs at a very unfavorable time when funds are short and urgently needed for much more important applications and when manpower and training in radiation protection and radiology are barely sufficient for the most urgent needs.

- We are buying a "pig in a poke" by adopting a system which has not been tested or evaluated at all in practice and which is obviously neither desired nor accepted by the practitioners.

Can we really take this responsibility as health physicists, scientists and citizens ?

#### 5. A PROPOSAL FOR A COMPROMISE AND FOR ACTIONS BY I R P A

In order to avoid an unfruitful polarization between supporters and opponents of the SI units, the only reasonable solution, at least for the decade to come, seems to be the coexistence of the old and new units. There is no need to hurry with a final solution as the practitioners are still happy with the old units and the SI supporters may use the new ones if they dare.

What we need is sufficient time for a serious, objective and thorough study of the real needs, problems and possible solutions, including compromises. The yet open problems of certain radiological quantities must be solved before we can attempt a final solution for the units. We must improve cooperation and should use the available time for sampling the opinions of all concerned. Once suitable proposals have been found, sufficient time should be allotted for a thorough evaluation and practical testing and for assuring the acceptance by a majority.

These are the reasons for a motion by the Fachverband für Strahlenschutz to the General Assembly of IRPA. We believe that IRPA due to its structure and wide range of members is the predestinated body for coordinating the efforts towards a solution of this problem. We propose that :

1. IRPA takes action to reconsider and reevaluate the problem of the radiological units in connection with the SI system in order to work out an optimal and practicable solution without undue risks and costs;
2. IRPA sets up a working group or committee for the management of this problem;
3. This working group organizes an inquiry among the Associate Societies and their members with the aim to get representative opinions and proposals on all questions and problems submitted by the working group;
4. The working group evaluates the answers of the Societies and works out a proposal for a representative statement by IRPA, proposes further actions by IRPA, submits the above proposals to the Associate Societies and to the Executive Council of IRPA in such time that a discussion can be held and decisions can be taken at the 5th International Congress of IRPA and at the corresponding General Assembly.

We do not urge you to decide now for or against the SI units. All we ask for is cooperation, time and support in order to find a satisfactory, reasonable and practicable solution for this and for similar future problems. We are seeking a solution which will not be introduced before it will be ready for general acceptance, which will last for a sufficient period, which we can support with good conscience and from which we will get a real benefit for radiation protection without unnecessary and undue risks, costs and complications.

PROGRAMME D'INTERCOMPARAISON DE DOSIMETRES DANS LA  
COMMUNAUTE EUROPEENNE EN MATIERE DE RADIOPROTECTION  
(F. Bertram \*), G. Brusoli \*\*), H. Seguin \*\*\*)

- \*) Commissariat à l'Énergie Atomique  
\*\*) Comitato Nazionale per l'Energia Nucleare  
\*\*\*) Commission des Communautés Européennes

Depuis 1964, la Direction Santé et Sécurité de la Commission des Communautés Européennes procède, en liaison avec des instituts et laboratoires spécialisés des 9 Etats membres à des intercomparaisons de dosimètres individuels. Ces intercomparaisons ont pour objectif d'améliorer la surveillance en matière d'irradiation et de permettre d'effectuer les contrôles sur une base commune; elles touchent donc directement à un aspect du contrôle physique, tel que réglé dans la Directive du Conseil des Communautés Européennes, du 1er juin 1976, fixant les normes de base révisées relatives à la protection sanitaire de la population et des travailleurs contre les dangers résultant des rayonnements ionisants.

Les travaux portent actuellement sur deux domaines :

- 1) Réalisation de programmes d'intercomparaison (Photons, neutrons, rayonnement bêta).
- 2) Réalisation d'expériences spécifiques.

#### 1. REALISATION DE PROGRAMMES D'INTERCOMPARAISON

##### Dosimètres à photons

Des dosimètres intégrateurs ont été irradiés avec des photons dans des conditions déterminées et les résultats comparés après lecture. Tandis que pour les premières intercomparaisons on avait utilisé presque exclusivement des dosimètres photographiques, on a, pour la dernière, utilisé à part égale des dosimètres à thermoluminescence et un certain nombre de verres dosimètres. Pour cette dernière intercomparaison des rayons X ont été utilisés (tension de 60, 110, 200 et 300 kV) et l'on s'est servi du rayonnement Gamma d'une source  $^{60}\text{Co}$ . Deux dosimètres par participant ont été irradiés par un mélange de rayons X et Gamma. 30 instituts de lecture ont présenté 43 séries de dosimètres, chaque série étant composée de 24 dosimètres, dont 20 ont été irradiés et 4 ont servi de témoins. Des examens antérieurs avaient fait supposer que les paquets envoyés par poste étaient passés aux rayons X. Ceci n'a pas pu être constaté cette fois.

Les irradiations ont été réalisées dans quatre instituts, à savoir au Commissariat à l'Énergie Atomique (CEA) de Fontenay-aux-Roses, à la Physikalisch-Technische Bundesanstalt (PTB) de Braunschweig, au Rijks-Instituut voor de Volksgezondheid (RIVM) de Bilthoven et à la Gesellschaft für Strahlen- und Umweltforschung (GSF) de Munich. La concordance entre les instituts ressort du Tab. 1. A la lecture, la valeur mesurée a été chaque fois normalisée sur la valeur de consigne. L'ensemble des valeurs obtenues est reproduit au Tab. 2.

##### Dosimètres à neutrons

Une intercomparaison de dosimètres à neutrons (essentiellement des films à émissions nucléaires) a été réalisée en 1970 et 1971. Les dosimètres ont été irradiés au Bureau Central de Mesures Nucléaires (BCMN) de Geel avec des neutrons monoénergétiques de 0,5, 0,7, 1,5, 4,5 et 13,6 MeV et des neutrons d'une source Am-Be. Les écarts systématiques entre les laboratoires, constatés lors de la première intercomparaison, avaient disparu.

lors de la seconde. L'expérience a montré également que les neutrons d'énergie inférieure à 0,7 MeV ne peuvent pratiquement pas être décelés et que seules les valeurs de doses provenant des neutrons proches de l'énergie utilisées pour l'étalonnage étaient décelées. Les énergies plus faibles sont très sous-estimées, tandis que les énergies plus fortes sont sur-estimées.

Ce type d'intercomparaison ne permettant à l'époque de réaliser aucun progrès, les expériences ont été suspendues afin d'attendre la mise au point de nouveaux dosimètres, elles vont être reprises en 1977 par la GSF de Munich. On attend une certaine amélioration par dosimètres à Albedo.

#### Dosimètres à rayonnement Bêta

Une première intercomparaison de dosimètres Bêta est en préparation; elle sera réalisée au courant de 1978.

## 2. EXECUTION D'EXPERIENCES SPECIFIQUES

### Journées d'expérimentation à Bologne

En 1974 des dosimètres à thermoluminescence de différents laboratoires ont été expérimentés en commun au Comitato Nazionale per l'Energia Nucleare (C.N.E.N.) de Bologne. L'objectif principal était de vérifier la reproductibilité et d'étudier l'enregistrement de doses inconnues.

Fresque tous les appareils de mesure à thermoluminescence se trouvant sur le marché européen étaient présents. Les dosimètres ont été irradiés avec des rayons X et Gamma sous des conditions déterminées. Pour tester la reproductibilité, deux irradiations par jour avec le rayonnement Gamma du  $^{60}\text{Co}$  et des doses d'environ 1 mGy et 20 mGy ont été exécutées pendant 5 jours. La reproductibilité trouvée ainsi était très bonne, les déviations maximales étaient de + 3 %.

Pour évaluer des doses inconnues, les dosimètres ont été irradiés avec des rayons de 77 keV, 180 keV et 1,25 MeV ( $^{60}\text{Co}$ ). Les doses se trouvaient entre 1 mGy et 20 mGy. On constate pour les dosimètres étalonnés avec le rayonnement du  $^{60}\text{Co}$  pour 180 keV une sur-estimation de 20 % et pour 77 keV une sur-estimation de 30 %. La concordance entre les différents laboratoires se trouvait entre 2 et 4 %.

### Journées d'expérimentation à Fontenay-aux-Roses

Des expériences ont été exécutées en 1975 avec des rayonnements de photons monochromatiques de 10 keV à 300 keV et 8,5 MeV au Laboratoire Central des Industries Electriques et au Commissariat à l'Energie Atomique de Fontenay-aux-Roses.

La dosimétrie de référence était celle du Bureau National de Métrologie français. Le débit de dose du faisceau de  $\gamma$  de capture était exprimé en "débit de dose absorbée maximal dans un fantôme d'eau" mesuré par la méthode du  $C_{\lambda}$ .

1) Dosimétrie de référence : Un certain nombre de participants ont irradié des chambres d'ionisation servant d'étalons de transfert au  $^{60}\text{Co}$  et aux  $\gamma$  de capture de 8,5 MeV, avec les épaisseurs de paroi appropriées. Les résultats montrent une très bonne concordance. Déviation maximale 0,5 % pour le rayonnement  $^{60}\text{Co}$ , environ 4 % pour le rayonnement de 9 MeV.

2) Irradiations par les  $\gamma$  du  $^{60}\text{Co}$  : Tous les dosimètres (films, verres, thermoluminescents) irradiés dans les faisceaux de  $\gamma$  du  $^{60}\text{Co}$  donnent des résultats très voisins de la dosimétrie de référence (figure 1) à condition de ne prendre en compte que ceux dont l'épaisseur de la paroi est suffi-

sante pour assurer l'équilibre électronique.

3) Irradiations aux X de faible énergie : La figure 1 montre la grande dispersion des résultats pour la raie de fluorescence de 9,9 keV. Cette dispersion provient de l'inadaptation de certains dosimètres aux mesures des faibles énergies (Z très différent de celui de l'air, épaisseur de paroi trop forte).

Pour un même type de dosimètre - par exemple FLi thermoluminescent - les résultats des différents expérimentateurs sont remarquablement comparables malgré les différences de conditionnement (épaisseur de paroi). L'expérience à Bologne a montré le même effet (voir fig. 2).

4) Irradiations aux  $\gamma$  de 0,1 MeV : La fig. 1 montre la répartition des dosimètres en deux catégories qui se manifestent par deux pics de la "courbe 9 MeV" :

- les dosimètres à faible Z et faible paroi donnent des résultats de l'ordre de la moitié de la dose absorbée maximale dans un fantôme d'eau;
- les dosimètres de Z élevé et à paroi épaisse (film sous écran de Pb, ou compteur GM à paroi d'acier) donnent des résultats voisins du double de la dose maximale dans l'eau.

Ce type d'intercomparaison met simultanément en évidence l'accord sur la dosimétrie de référence ( $\gamma$  du  $^{60}\text{Co}$ ) et les difficultés rencontrées pour faire de bonnes mesures tant au voisinage de 10 keV qu'à celui de 10 MeV. Dans tous les cas l'influence des parois entourant l'élément détecteur est déterminante et il apparaît bien qu'on ne peut couvrir toute cette gamme d'énergie avec un dosimètre unique, à moins qu'il ne soit composé de plusieurs détecteurs sous des écrans différents.

Les problèmes de la dosimétrie des rayons X de faible énergie étaient bien connus et plus ou moins bien résolus par les détecteurs thermoluminescents de Z faible ou par les films à écrans multiples. De plus en plus, les laboratoires de dosimétrie individuelle vont se trouver confrontés à des problèmes de mesure de  $\gamma$  de forte énergie ( $\gamma$  de capture au voisinage des réacteurs, rayonnement de freinage auprès des accélérateurs médicaux). Il est donc nécessaire de pouvoir contrôler périodiquement les performances des systèmes de mesure dans toute l'étendue de ces gammes d'énergie.

#### Journées d'expérimentation à Braunschweig

La Physikalisch-Technische Bundesanstalt procédera cette année, en collaboration avec 14 instituts nationaux des différents pays de la CE, à l'étude des dosimètres à neutrons, lesquels seront irradiés avec des neutrons de différentes énergies (thermique, microénergétique dans la gamme keV jusqu'à 20 MeV, spectres de fission et spectres de sources radioactives).

La CCE exprime ses remerciements à tous les participants de la fructueuse collaboration qui s'est instaurée durant la mise en œuvre et l'exécution du programme d'intercomparaison européen.

TAB 1 MEAN VALUES OF <sup>60</sup>Co IRRADIATION

	$\bar{D}$	s
GSF	100	0.21
	0.98	0.15
RIV	0.96	0.20
	0.96	0.19
CEA	0.96	0.22
	0.96	0.15
PTB	1.00	0.19
	0.98	0.14

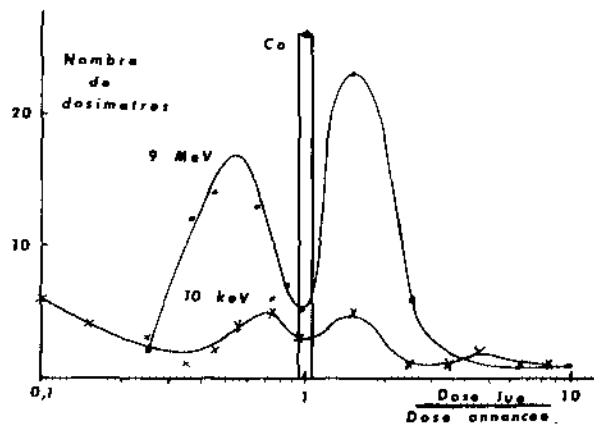
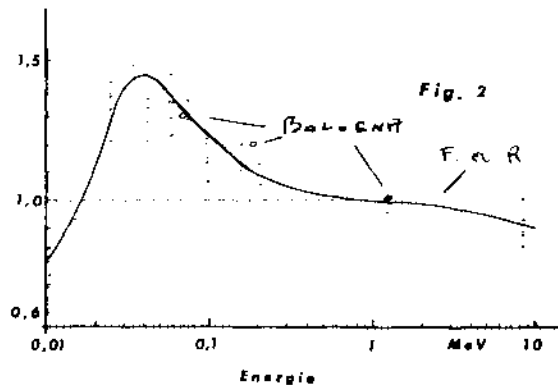

Fig. 1 REPARTITION DES RESULTATS

TAB 2

INTERCOMPARAISON 1974/1975  
(PHOTON)

	$\bar{D}$	s
TLD	1.03	0.22
FILM	1.13	0.38
GLASS	0.91	0.09
ALL VALUES	1.07	0.31



REPONSE DU FILM EN FONCTION DE L'ENERGIE

AN INTERNATIONAL CO-ORDINATED RESEARCH PROGRAMME ON NUCLEAR  
ACCIDENT DOSIMETRY

F.N.Flakus  
Radiological Safety Section  
Division of Nuclear Safety and Environmental Protection  
International Atomic Energy Agency  
Kärntnering 11, P.O.B. 590  
A-1011 Vienna, Austria

## 1. INTRODUCTION

Where fissile materials are being processed in quantities exceeding the minimum critical amounts, a radiation risk to workers would arise from the possibility of criticality excursions. Techniques and procedures for preventing the occurrence of such accidental excursions have reached very high standards. This is very well reflected in the exceedingly small number of criticality accidents which have been reported so far. 35 criticality accidents have been documented since 1944. Only one criticality accident has been reported during the last 10 years, a period within which the world's inventory of fissile materials has been substantially increasing. Despite this very laudable safety record it is generally agreed that specially designed criticality dosimetry systems should continue to be available to provide, in case of an accident, information on personal neutron and gamma ray exposure within required accuracies at required times for the guidance of the medical services in appropriate medical treatment of more heavily exposed personnel and for reassuring personnel who have only been slightly exposed.

## 2. IMPLEMENTATION OF PROGRAMME

In February 1969 the IAEA convened a panel of dosimetry experts to review the experience gained in assessing doses to persons exposed to nuclear radiations in criticality accidents (1). Following the recommendations of this panel the IAEA, subsequently, established an international co-ordinated research programme on nuclear accident dosimetry with the aim of improving the performance of existing nuclear accident dosimetry systems and elaborating standardized systems that would perform within criteria laid down by this panel. The opinion of the experts was that an adequate system should provide data to enable an initial determination of the maximum absorbed dose in the body within 48 hours with an uncertainty of less than 50% of its neutron and gamma components separately, and, if initial determination yields dose estimates greater than 0.25 Gy (25 rad) to a significant portion of the body, to enable an estimate within four days with an uncertainty of less than 25%.

A number of research contracts and research agreements, supporting theoretical studies as well as experimental work in the subject area, were concluded with laboratories in 13 Member States (Bulgaria, Canada, Czechoslovakia, France, Federal Republic of Germany, Hungary, India, Japan, Poland, UK, USA, USSR, Yugoslavia). Research Co-ordination meetings were organized in order to facilitate exchange of ideas and to avoid undesirable duplication of work.



### 3. INTERCOMPARISON STUDIES

In addition to the regular research co-ordination meetings, international multilaboratory intercomparison experiments were organized for testing and calibrating existing criticality dosimetry systems in different neutron spectra under simulated accident conditions. Since 1970 four intercomparison experiments were held, at Valduc (France) in 1970, at Oak Ridge (USA) in 1971, at Vinca (Yugoslavia) in 1973 and at Harwell (UK) in 1975. In addition to research groups from 13 Member States listed earlier, experts from Italy and Denmark also participated in the experiments. Some information on these experiments is summarized in Table 1.

Experiment:	I	II	III	IV
Years:	1970	1971	1973	1975
Location:	Valduc (France)	Oak Ridge (USA)	Vinca (Yugoslavia)	Harwell (UK)
Facility:	C.R.A.C.	HPHR	RB 2	Viper
Neutron Spectrum:	well moderated	unmoderated	heavy moderated	well moderated with broad peak from 1 keV to 1 MeV
Number of different radiation fields utilized:	2	3	1	1
Number of criticality excursions:	2	4	2	2
Number of participating research groups:	13	17	19	17
Number of participating Member States:	10	12	13	12

TABLE 1: IAEA International Intercomparison Experiments on Nuclear Criticality Accident Dosimetry during the period 1970 - 1975.

A great variety of dosimeters for personnel and area dosimetry were exposed in these experiments to seven qualitatively different mixed neutron - gamma radiation fields. In total ten criticality excursions of the order of  $10^{17}$  -  $10^{18}$  fissions were provided for examining the response of the dosimetry systems. The neutron- and gamma doses generated ranged from 0.1 Gy - 5 Gy (10 rad to 500 rad). Personnel dosimeters were exposed in free air as well as mounted on phantoms. Orientational studies, taking into account the direction of the incident radiation, were made. Sodium activity measurements in phantom parts were also carried out. Participants were requested to produce first data within 48 hours of each of the pulses. Later final data had to be given including information on number of activated atoms per  $10^{10}$  atoms, on neutron fluence in defined energy intervals and on neutron and gamma doses. Detailed information on the components of the dosimetry systems employed, the measurement and evaluation

procedures used and the results obtained at the four intercomparison studies is reported in Refs.(2,3,4,5,6). The last intercomparison experiment at the Viper facility in the UK with its high intensity component in the intermediate neutron energy region provided a most stringent test for the dosimetry systems employed. There were no significant differences between the mean results obtained by the participants within 48 hours of the pulse and after full evaluation. However, a significant reduction in the variation of the results between participants was observed, resulting in a reduction of the final standard deviation. Variations in the final mean were up to 20% for neutron dose and up to 25% for gamma dose for all participants(5). The results demonstrate that several systems are available now in a number of laboratories throughout the world that perform within the criteria laid down by the initiating panel in 1969.

#### 4. RESULTS

The work carried out under this co-ordinated research programme by the contractors in the 13 Member States is reported in about 100 papers published in the open literature. These publications reflect the improvement of nuclear accident dosimetry systems since 1969. A number of interesting general points emerged from the intercomparison studies. Only two more important ones are addressed below:

- i) The simpler the measuring system is, the more subsequent complex analysis is required. Many of the nuclear accident dosimetry systems that were developed over the last ten years are still evolving and there is still a diversity of opinion on the optimum method. However, in order to assist Member States and particularly developing countries in adopting a criticality accident dosimetry system for the first time, a comprehensive technical manual on nuclear accident dosimetry is being prepared by the IAEA with the help of experts from among the participants in this programme. The description of a minimal acceptable nuclear accident dosimetry system will be part of this manual (7).
- ii) In a criticality accident, dose estimates to the required accuracy can only be obtained with existing systems if a reasonable approximation to the actual neutron spectrum involved is readily available. As an aid for dose evaluations, a compendium of neutron leakage spectra has been compiled, encompassing the most likely neutron spectra encountered in criticality accidents. 64 different neutron spectra, presented in tabulated form as well as graphically, are included in the compendium. Together with each set of spectral information average cross sections for a number of common detectors are also given to facilitate the application of spectral data to dosimetry. It is planned to publish the compendium under the IAEA Technical Reports Series in the near future(8).

In conclusion it can be said that the co-ordinated research programme provided a most efficient means for harmonizing multinational efforts and solving scientific problems in the subject area. The great advantage of the international intercomparison experiments for the participating experts was not only the opportunity to compare a variety of individual methods under simulated accident conditions but also the opportunity of access to facilities in different Member States providing unique radiation fields for calibrating nuclear accident dosimetry systems.

## 5. REFERENCES

- (1) IAEA, "Nuclear Accident Dosimetry Systems", Proceedings of a Panel, Vienna, 17-21 February 1969, IAEA, Vienna, Publication STI/PUB/241 (1970).
- (2) IAEA, "First IAEA Measurement Intercomparison, Valduc, France, 15-26 June 1970"(internal report).
- (3) HAYWOOD, F.F. and COSTON, J.W., "Second IAEA Nuclear Accident Dosimetry Co-ordination Meeting and Intercomparison Experiment, 3-15 May 1971", ORNL-TM-3770 (internal report).
- (4) MIRIĆ, I. and UBOVIĆ, Y., "Third IAEA Nuclear Accident Intercomparison Experiment, 14-25 May 1973", IRK-1274, Boris Kidric Institute, Vinca, Yugoslavia (internal report).
- (5) GIBSON, J.A.B., DELAFIELD, H.J., READING, A.H., "Nuclear Accident Dosimetry, Report on the Fourth IAEA Intercomparison Experiment at Harwell, UK, 7-18 April 1975, Part I, Description of the Experiment and Participants Results", AERE-R 8520, (in print).
- (6) GIBSON, J.A.B., "Nuclear Accident Dosimetry, Report on the Fourth IAEA Intercomparison Experiment at Harwell, UK, 7-18 April 1975, Part II, Systems used by Participants at the Experiment", AERE-R 8521 (in print).
- (7) IAEA, "Technical Manual on Nuclear Criticality Accident Dosimetry", (in preparation).
- (8) ING, H. and MAKRA, B., "Compendium of Neutron Spectra for Criticality Accident Dosimetry", IAEA Technical Reports Series (to be published).

ETAT ACTUEL DES METHODES DE MESURE DE LA DOSE GAMMA DANS LES CHAMPS MIXTES

N. Parmentier\*, A. Riccart\*, V.D. Nguyen\*, R. Médioni\*\*, J.C. Ferrier\*

1. INTRODUCTION

Les intercomparaisons sur la dosimétrie neutronique faites dans le cadre de l'ENDIP (European Neutron Dosimetry Intercomparison Project) au "INC" et au "USF", en 1975, ont permis d'après les résultats obtenus de faire un choix parmi les différents détecteurs utilisés.

Si, à l'heure actuelle, l'utilisation d'une chambre d'ionisation en plastique équivalent-tissus baignée par du gaz équivalent-tissus semble la seule méthode viable pour la mesure de la dose totale, le choix est moins évident pour la mesure de la dose gamma.

2. ESTIMATION DES DOSES EN CHAMPS MIXTES - PRINCIPE (1)

D'après le nouveau rapport de l'I.C.R.U. "Neutron dosimetry for biology and medicine" (sous presse), les doses neutron et gamma sont reliées à la réponse des différents détecteurs par les relations suivantes :

$$R'_D = k_T D_N + k_U D_G \quad \text{et} \quad R'_U = k_U D_N + h_U D_G$$

où  $D_N$  et  $D_G$  sont les doses absorbées neutron et gamma en rad dans les tissus.  $k_T$  et  $k_U$  sont la sensibilité de chaque dosimètre aux neutrons, relativement à la sensibilité aux gamma utilisées pour l'étalonnage.  $h_U$  et  $h_T$  sont la sensibilité de chaque dosimètre aux photons dans le champ mixte relativement à la sensibilité aux gamma utilisés pour l'étalonnage avec l'hypothèse couramment admise actuellement  $h_T = h_U = 1$ .

Le paramètre  $k_T$  précédemment défini est donné par :

$$k_T = (\bar{W}_C / \bar{W}_N) \cdot S(m,g)_C \cdot S(m,g)_N^{-1} \cdot (K_T / K_m)_C \cdot (K_T / K_m)_N^{-1}$$

où  $\bar{W}_C$  et  $\bar{W}_N$  sont l'énergie moyenne correspondant à la création d'une paire d'ions pour les électrons et pour les particules lourdes chargées.

Le rapport  $\bar{W}_C / \bar{W}_N$  est pris égal à 0,95 (recommandation I.C.R.U.).

$K_T / K_m$  est le rapport du kerma dans les tissus à celui du matériau du dosimètre utilisé. Il dépend de l'énergie des neutrons.

Compte tenu de ces hypothèses, les doses dans un champ mixte sont obtenues par :

$$D_N = (R'_T - R'_U) \cdot (k_T - k_U)^{-1} \quad \text{et} \quad D_G = R'_U - k_U D_N \quad \text{avec} \quad k_T = 0,95 (K_T / K_m)_N^{-1}$$

3. SENSIBILITE AUX NEUTRONS ( $k_U$ ) DES DOSIMETRES UTILISES à l'ENDIP

Le compteur S.K. utilisé est construit en s'inspirant du modèle de HURST (2) en ce qui concerne les écrans (plomb - étain - lithium 6). La chambre

\* Département de Protection - Service de Protection Sanitaire  
Commissariat à l'Energie Atomique - BP n° 6 92260 FONTENAY AUX ROSES  
\*\* Département de Protection - Service Technique d'Etudes de Protection -  
Commissariat à l'Energie Atomique - BP n° 6 92260 FONTENAY AUX ROSES

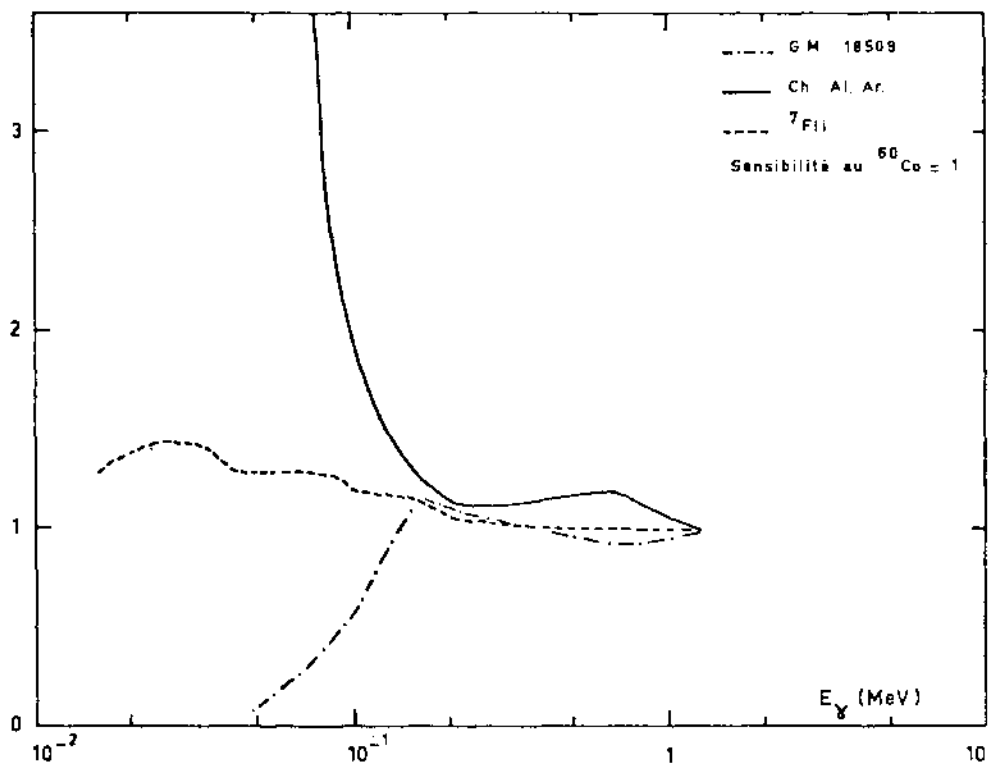

À paroi d'aluminium balayée par de l'argon est construite au laboratoire (3). Le fluorure de lithium est enrichi à 0,9995 en isotope 7. Les films sont des émulsions Kodak type I exposés sous un emballage de plomb ( $1,1 \text{ g cm}^{-2}$ ), selon la technique préconisée par D. BENTLEY (4).

Le tableau 1 résume les sensibilités aux neutrons de ces différents dosimètres.

Energie neutrons (MeV)	Dosimètre				
	0,7	2,1	5,5	15	Fission
G.M. (1)	0,001	0,001	0,002	0,004	0,001
G.M. (2)				0,012	
Al - Ar (1)	0,014	0,012	0,011	0,13	0,02
Al - Ar (3)	0,017	0,017	0,029	0,127	0,017
Al - Ar (4)			0,019	0,115	
<sup>7</sup> FLI (5)	0,021	0,021	0,047	0,16	0,021
<sup>7</sup> FLI (6)	0,0135	0,014	0,039	0,25	0,053
G.M. (7)	0	0	0,006	0,008	0
Film (7)	0,0014	0,0015	0	0	0,007

(1) Goodman et Colvett 1974. (2) Lewis 1976. (3) Chertob et Ricourt calcul 1973. (4) Ricourt et Nguyen 1975. (5) Wingate et Tschilin 1965. (6) Portal 1975. (7) Médioni 1975 (réponses relatives G.M. et films).

#### 4. SENSIBILITE AUX PHOTONS ( $\gamma$ ) DES DOSIMETRES UTILISES A L'ENDREUF

Nous nous sommes essentiellement attachés à déterminer la sensibilité du G.M. et de la chambre aluminium-argon utilisés en étudiant sa réponse dans des faisceaux monochromatiques de différentes énergies. Pour le fluorure de lithium, la courbe de sensibilité est donnée par G. PORTAL (5). La figure ci-contre résume tous ces résultats.

### 5. CALCUL DES INCERTITUDES SUR $D_K$ et $D_G$ : CONTRIBUTION DE $k_U$

Les équations suivantes permettent d'estimer les incertitudes sur  $D_K$  et  $D_G$ :

$$\frac{\Delta D_K}{D_K} = \frac{\Delta R'_{U'}}{R'_{U'}} + \frac{\Delta R'_{U''}}{R'_{U''}} + \frac{\Delta k_U}{k_U} + \frac{\Delta k_U}{k_U - k_U}$$

$$\frac{\Delta D_G}{D_G} = \frac{\Delta R'_{U'}}{R'_{U'}} + \frac{k_U \Delta D_K}{R'_{U''} - k_U D_K} + \frac{D_K \Delta k_U}{R'_{U''} - k_U D_K}$$

Nous prendrons comme exemple les résultats que nous avons obtenus lors de l'intercomparaison ENDFP, dans le cas où le rapport  $D_K/D_G$  est de 0,032 (cas le plus défavorable pour l'estimation de  $D_G$ ) et ceux obtenus lors de l'intercomparaison INDI (6) pour un rapport  $D_K/D_G$  égal 0,45.

Si l'on fait l'hypothèse que l'on dispose d'un dosimètre gamma totalement insensible aux neutrons ( $k_U = 0$ ) on peut déterminer l'erreur commise sur l'estimation des doses due aux autres paramètres. Dans ce cas, l'erreur maximale quelle que soit l'énergie des neutrons est de  $\pm 11 \%$  sur  $D_G$  et de  $\pm 3,6 \%$  sur  $D_K$ .

Dans le cas où  $k_U$  varie entre quelques pour cent et 13 %, l'erreur commise sur les doses peut atteindre  $\pm 14 \%$  pour  $D_G$  dans le cas des neutrons de 10 MeV (cas le plus défavorable) mais l'erreur sur  $D_K$  est de  $\pm 0,7 \%$  seulement.

Dans le cas des neutrons de fission,  $k_U$  est de l'ordre de quelques pour cent et dans ce cas l'erreur sur  $D_G$  est de  $\pm 4 \%$ , et sur  $D_K$  de  $\pm 4 \%$  également.

### 6. CONCLUSION

Dans le domaine de la radioprotection, pour les mesures dans l'air, le compteur G.M. apparaît comme un dosimètre gamma satisfaisant, permettant de déterminer les sensibilités  $k_U$  d'autres dosimètres. Une réserve cependant doit être faite : les gamma de fission ont un spectre qui s'étend jusqu'à quelques MeV. Des travaux récents sembleraient montrer une sensibilité élevée  $k_U$  pour le G.M. aux hautes énergies  $\gamma$  : il sera donc nécessaire de faire cette étude dans des faisceaux monochromatiques de 6 et 9 MeV.

Dans le domaine de la radiobiologie, et de la dosimétrie dans un fantôme faite dans le cas d'irradiation accidentelle, la sensibilité  $k_U$  du G.M. pose un certain nombre de problèmes et la précision de la connaissance des facteurs  $k_U$  doit être améliorée.

### REFERENCES

- (1) RICOURE, A., NGUYEN, V.D., MEDICHI, R., FERLIER, E.C., CEA R-4793 (1976).
- (2) WAGNER R.B., HURST, G.S., Health Phys. 5 (1961).
- (3) CHEMTOB, M., RICOURE, A., et al., Biomedical dosimetry, Vienna, 10-14 March 1975, Vienna A.I.B.A., (1975) 39-62.
- (4) BEWLEY D.K., PARROTT, G.L., Brit. J. Radiol. 42 (1969).
- (5) PORETAT, G., CEA R-4697 (1975).
- (6) CHEMTOB, M., SOULIE, R., Compte rendu de l'intercomparaison internationale de dosimétrie neutronique (I.N.D.T.) 14-25 mai 1973 (à paraître).

STANDARDIZATION OF RADIATION PROTECTION MEASUREMENTS  
IN MIXED FIELDS OF EXTENDED ENERGY RANGEM. Hüfert and G.R. Stevenson  
CERN, Geneva

## 1. INTRODUCTION

In stray radiation fields encountered outside the main shield of a multi-GeV proton accelerator the dose equivalent cannot be measured directly but has to be evaluated from a series of measurements taking into account the different radiation components of an extended energy range. Furthermore the correspondence in the case of such an external irradiation in such a field between the dose equivalent values established by an area measurement (area dose), the dose equivalent accumulated on a personal monitoring device (personal dose) and the dose equivalent possibly received by the person in the stray field (whole-body dose) has to be understood. Clear and simple relations between these three values exist only for defined irradiation situations which coincide largely with calibration conditions: dose equivalent distributions are calculated for parallel broad beams and different types of particles of various energies in anthropomorphic phantoms. Radiation survey instruments are exposed to similar beams of known spectral composition and the detector response is made to match the calculated values closely. Personnel dosimeters are irradiated on phantoms and their reading is interpreted to coincide with the whole-body dose in defined conditions.

This approach is the accepted procedure in the case of neutrons. For photon irradiation the assessment of radiation risk is traditionally made in terms of "exposure" which is transformed into tissue dose by nearly energy independent conversion factors. Exposure will however, in the case of an extended field of one-sided incident photons on a body, underestimate the dose equivalent at nearly all energies and for many organ sites due to the influence of backscatter (1).

## 2. APPROACHES TO STANDARDIZATION

A standardization of radiation protection measurements for all types of radiation was proposed by ICRU in terms of dose equivalent index (2). The maximum dose equivalent in a tissue equivalent sphere of 30 cm diameter either in the shell (shallow) or in the inner core (deep) should be regarded to be the concept when dealing with whole-body exposures.

Another approach considers for radiation monitoring purposes the locations of critical organs in the body and arrives at defined and constant depths (3). Keeping the ICRU sphere as the standard phantom the International Electrotechnical Commission (IEC) proposes a fixed depth of 800 mg cm<sup>-2</sup> as relevant for dose equivalent meters measuring "depth dose equivalent" for photon and beta irradiation (4).

In the case of neutrons, additivity and cumulativity of dose equivalent can be assured by taking the average value which will result from Monte Carlo calculations in a phantom over the first centimetre as the relevant risk parameter (5).



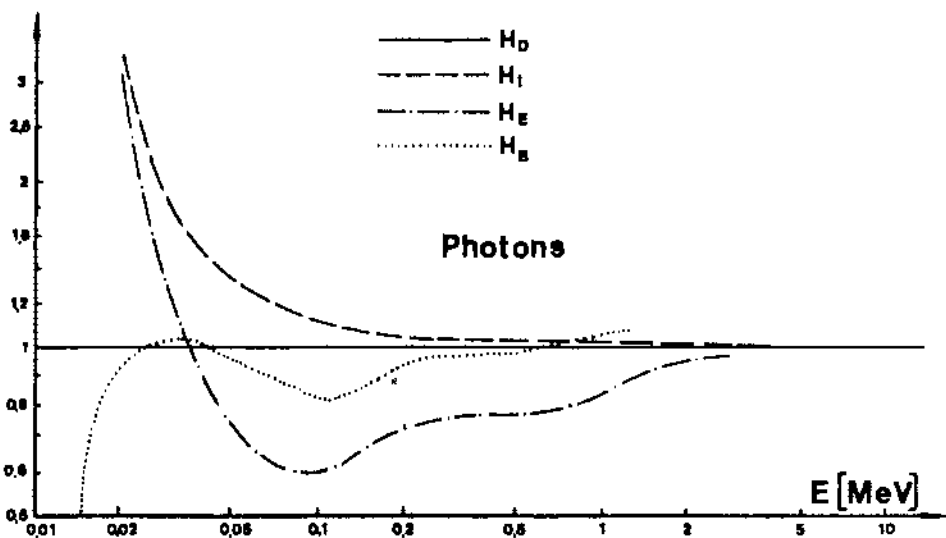

Fig. 1. Ratio between shallow dose equivalent index  $H_T$  and tissue dose  $H_E$  to depth dose equivalent  $H_D$  as a function of photon energy. Response function of radiation survey instrument Eabyline  $H_B$ .

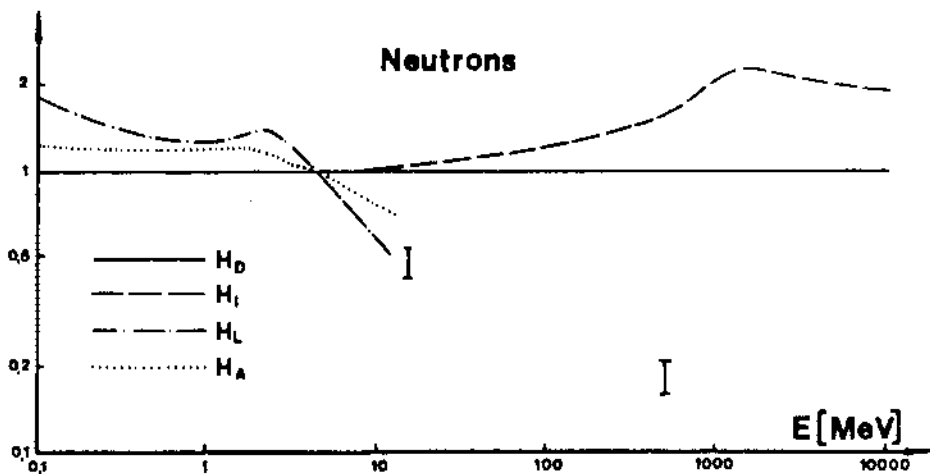

Fig. 2. Relation between deep dose equivalent index  $H_I$  and depth dose equivalent  $H_D$  as function of neutron energy. Measured response function of moderator instrument  $H_A$  and  $H_L$  (7,8). Points at 14 and 500 MeV were measured for a rem ionization chamber at CERN.

### 3. PHOTONS

Considering the depth dose equivalent  $H_D$  behind a fixed depth of  $800 \text{ mg cm}^{-2}$  as representative for a whole body exposure, this quantity is compared with tissue dose derived from exposure  $H_E$  and the shallow dose equivalent index  $H_I$  over an energy range from 10 keV to 10 MeV (fig. 1). An estimation of  $H_D$  was based on results for an elliptical phantom between 100 keV and 10 MeV. Not much difference is expected when changing the phantom to the ICRU sphere (6). As around 100 keV a good correspondence was found between calculations and reported phantom measurements, the curves were extrapolated to lower energies. It can be seen that tissue dose  $H_E$  based on an exposure measurement will underestimate  $H_D$  over a wide range of photon energies. Depth dose equivalent  $H_D$  is however a good approximation to shallow dose equivalent index  $H_I$  from 10 MeV down to 70 keV. For lower energies the skin dose equivalent (not defined by ICRU) has to be considered in specific situations to be the limiting quantity rather than  $H_I$ .

In some cases existing survey meters have to be modified only slightly to assess depth dose equivalent. For comparison the energy response of a widely used instrument (Babyline) equipped with a TE cap of  $800 \text{ mg cm}^{-2}$  and calibrated with photons from  $^{137}\text{Cs}$  is given. As its reading  $H_B$  stays relatively flat and close to one from 20 keV to 1.2 MeV, it can be considered as an excellent depth dose equivalent meter for photons.

### 4. NEUTRONS

In the case of neutrons the dose equivalent averaged over the first centimetre is regarded to be the depth dose equivalent  $H_D$  which coincides over a wide range of energies with the shallow dose equivalent index  $H_I$  (fig. 2). At energies above 10 MeV the deep dose equivalent index  $H_T$  will be higher by up to a factor of two for conditions of monoenergetic parallel broad beams of neutrons which are however not encountered in real situations, i.e., stray fields of an extended energy range where the maximum of the dose equivalent is again in the first centimetre of depth (5). Thus the concept of depth dose equivalent will remain valid even at higher neutron energies.

The problem at energies above 10 MeV is rather of a practical nature as conventional moderator instruments will considerably underestimate the desired quantity. The response function of the Andersson and Braun moderator as measured by two different authors ( $H_A$  and  $H_L$ ) plotted in fig. 2 will generally lead to a tolerable overestimation of  $H_D$  at lower energies (7,8). The two points shown in the figure were measured at CERN at 14 and 500 MeV for a rem ion chamber and show the serious underestimation of such an assembly at higher energies. Thus moderator instruments have to be backed up by other measurement techniques where the activation of  $^{11}\text{C}$  from  $^{12}\text{C}$  in a plastic scintillator in the case of neutrons above 20 MeV is widely used. The cross-section for the  $(n,2n)$  reaction is reasonably constant. As furthermore the depth dose equivalent increases only slowly with energy, it should be possible to use a single apparent fluence to dose equivalent conversion factor for typical spectra encountered around high energy proton accelerators. Pure neutron spectra will lead to a depth dose equivalent conversion factor from flux density of  $5.5 \pm 1.0 \text{ cm}^{-2} \text{ s}^{-1} \text{ mrem}^{-1} \text{ h}$  (9). However, in hard accelerator spectra, where the contribution to the activation from other hadrons becomes important, a conversion factor of  $9.2 \pm 2.0 \text{ cm}^{-2} \text{ s}^{-1} \text{ mrem}^{-1} \text{ h}$  was found (10).

## 5. MUONS

Around a high energy accelerator the muon component can at times dominate the stray radiation field. Muons behave like heavy electrons but their bremsstrahlung energy loss only becomes important at energies greater than 100 GeV. In real cases the energy spectrum of muons extends up to several GeV and often up to 100 GeV, therefore the fraction of muons that would stop in the body ( $E_{\mu} \approx 100$  MeV) and whose Bragg peak could give rise to higher than minimum energy deposition is unimportant in assessing the radiation risk.

As for other components of the field the depth dose equivalent below  $800 \text{ mg cm}^{-2}$  is a realistic approximation of the dose equivalent index from muons and is properly estimated by using a chamber suitable for evaluating photon dose equivalents.

## 6. CONCLUSIONS

The present ideas on the determination of dose equivalent in mixed radiation fields of an extended energy range are not found to be in contradiction with the concept of dose equivalent index. In all real situations the more practical approach of depth dose equivalent will be a good approximation to relevant index quantities.

## REFERENCES

- (1) Jones, A.R., Health Physics 12, 663 (1966).
- (2) ICRU Report 25, Washington 1976.
- (3) Commission of the European Communities, Radiological Protection Doc. EUR 5287e.
- (4) Int. Electrotechnical Commission, Draft Document 45B/WGB3(30).
- (5) Stevenson, G.R., et al., Proc. Symp. on Neutron Monitoring, Vienna (1973), Vol. I, p. 177.
- (6) Enz, R.W., and Murphy, H.M., Health Physics 24, 53 (1973).
- (7) Andersson, I.Ö., and Braun, J., Studsvik Report AE-132.
- (8) Larson, H.V., et al., Proc. Symp. Adv. Phys. Biol. Rad. Detectors, Vienna (1971), p. 553.
- (9) Stevenson, G.R., Rutherford Report RP/PN/56 (1971).
- (10) Höfert, M., et al., Proc. 8th Int. Congr. Soc. Française de Radioprotection, Saclay (1976).

COMPORTEMENT DE DOSIMETRES REUTILISABLES POUR LE CONTROLE  
INDIVIDUEL DE RADIOPROTECTION

J.-F. Valley, P. Jan, G. Pache et F. Lerch

Institut de radiophysique appliquée, Service de la Santé  
Publique, CH 1005 Lausanne et

Institut d'électrochimie et de radiochimie, Ecole Poly-  
technique fédérale, CH 1005 Lausanne

## 1. INTRODUCTION

La calibration de dosimètres non-réutilisables du type film photographique, s'effectue par échantillonnage. A cet effet, un certain nombre de films de chaque série est irradié à une dose connue et subit la procédure normale de développement et de mesure.

Dans le cas du dosimètre réutilisable, la mesure de la réponse de chaque dosimètre est non seulement possible, mais en général nécessaire car le procédé de fabrication ne garantit pas une réponse homogène par lot. De plus, un contrôle périodique de fonctionnement, motivé par la possibilité de vieillissement ou de défectuosité intervenant en cours d'utilisation, doit également être prévu.

Ces problèmes touchent non seulement l'aspect métrologique et la fiabilité du contrôle, mais ont également une incidence économique, car le parc de dosimètres et son entretien représentent un investissement élevé.

## 2. METHODES DE CALIBRATION ET DE CONTROLE

La méthode de calibration, consistant à vérifier que la réponse du dosimètre est située entre deux limites judicieusement choisies, a été largement utilisée. Le test périodique de fonctionnement est alors effectué de la même manière. L'alternative que nous avons choisie et qui consiste à attribuer à chaque dosimètre un facteur de calibration par élément sensible, est devenue pratiquement possible par l'emploi d'un ordinateur pour la gestion du contrôle. Les avantages de cette technique sont les suivants :

- meilleure surveillance du comportement des dosimètres en cours d'utilisation
- possibilité d'établir un rapport précis entre les doses enregistrées par différents éléments sensibles du dosimètre en vue de qualifier le rayonnement
- gestion optimisée du parc de dosimètres par une élimination plus sélective.

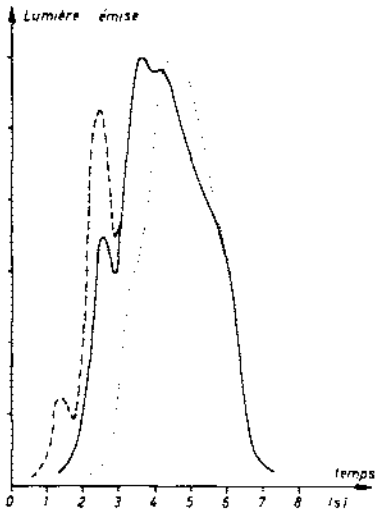

Fig. 1 Courbes de thermoluminescence  
 ---- lecture 1 mn après irradiation  
 ——— " 1 jour " "  
 ..... " 1 mois " "

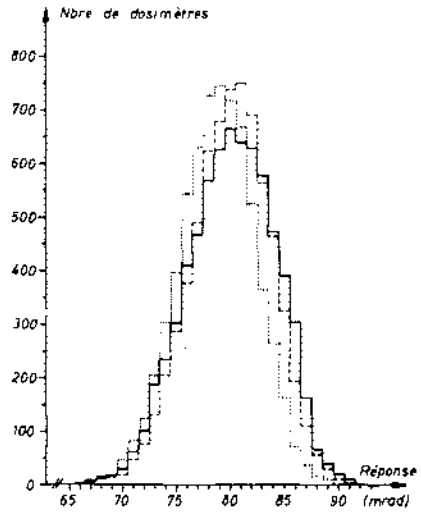

Fig. 2 Répartition de la réponse des dosimètres à 80 mrad  
 ——— calibration originale  
 ---- " après 1 an  
 ..... " après 2 ans

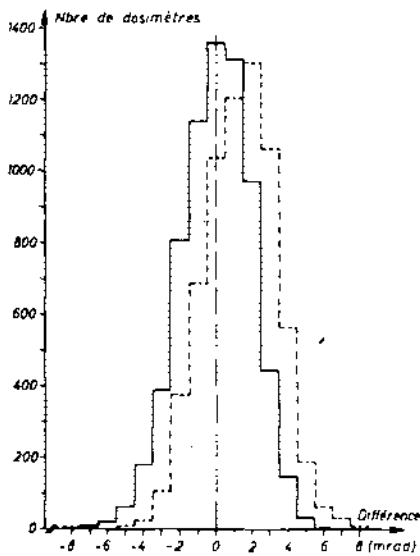

Fig. 3 Répartition de la différence entre les calibrations  
 ——— cal. originale - cal. après 1 an  
 ---- cal. originale - cal. après 2 ans

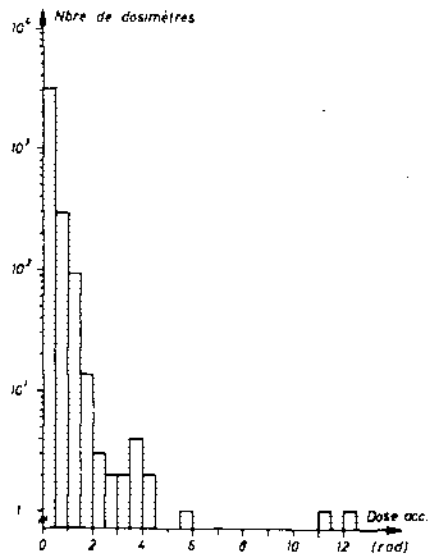

Fig. 4 Doses accumulées par les dosimètres au cours de 2 ans.

### 3. PROCEDURES DE CALIBRATION ET DE CONTROLE

Le système de mesure utilisé est l'installation Harshaw 2271. Le dosimètre comprend deux éléments sensibles (cristaux thermoluminescents au LiF) et un code d'identification.

A leur réception, les dosimètres, après mise à zéro, sont irradiés à une dose de 80 mrad de  $^{60}\text{Co}$  sur un carrousel. La lecture est effectuée 24 heures après l'irradiation. Le facteur de calibration est déterminé à partir de cette réponse, corrigée pour tenir compte du fading après 1 mois (voir réf. (1) et fig. 1). Le bruit de fond est ensuite mesuré pour s'assurer d'un fonctionnement normal du dosimètre.

Dans les conditions normales d'utilisation, la dose reçue est déterminée à partir des facteurs de calibration et selon un algorithme tenant compte de la réponse en énergie des dosimètres (voir réf. (2)).

La procédure de calibration est répétée annuellement et les dosimètres dont l'écart à la calibration initiale est supérieur à 10 % sont éliminés.

Outre les facteurs de calibration, la dose accumulée dans chaque élément sensible du dosimètre et le nombre d'utilisation sont tenus à jour. L'ensemble des informations est géré par ordinateur.

### 4. RESULTATS

La répartition de la réponse des dosimètres est représentée à la figure 2 pour la calibration initiale et les calibrations après 1 et 2 ans d'utilisation. L'écart standard est de 5,0 % et justifie la calibration individuelle des éléments sensibles dont le rapport des réponses est utilisé dans l'algorithme de calcul (voir réf. (2)). Les répartitions après 1 an et 2 ans d'utilisation restent centrées à 80 mrad et les écarts standards ne se modifient pas de manière significative.

Afin de mieux cerner l'évolution individuelle des dosimètres, nous avons représenté à la figure 3 les différences observées entre la calibration initiale et les 2 calibrations successives. L'écart standard des répartitions qui est de 2,0 % montre la grande reproductibilité des dosimètres et du système de lecture.

L'évolution du lot de dosimètres est indiquée au tableau 1. Les dosimètres éliminés lors d'une calibration ont soit montré une réponse aberrante lors de la calibration initiale, soit leur réponse aux calibrations consécutives a varié de plus de 10 %. Si cette circonstance ne peut être exclue, le nombre de dosimètres endommagés ou perdus est cependant d'un ordre de grandeur supérieur.

	Nombre de dosimètres
Lot original	3500
Dosimètres endommagés	47
Dosimètres perdus	69
Dosimètres éliminés lors des calibrations	9

Tableau 1. Evolution d'un lot de dosimètres

La répartition des dosimètres en fonction de la dose accumulée après 2 ans d'utilisation est donnée à la figure 4. Cette répartition est très représentative du domaine de contrôle, services médicaux, pour lequel les dosimètres sont utilisés. Aucune corrélation entre la variation de la réponse et la dose accumulée n'a pu être établie comme différents tests l'avaient laissé prévoir (réf. (2)).

#### 5. CONCLUSIONS

La méthode consistant à effectuer une calibration individuelle de dosimètres réutilisables pour le contrôle individuel de radioprotection nous apparaît optimale quant à l'exploitation des informations métrologiques et permet de limiter, dans le domaine des applications médicales, le nombre d'éléments sensibles à deux par dosimètre.

L'incidence de cette méthode sur l'aspect financier du contrôle est positive car elle permet de gérer avec un minimum de pertes le stock de dosimètres.

Le contrôle annuel de fonctionnement assure d'autre part la fiabilité nécessaire aux mesures individuelles.

#### REFERENCES

- (1) J.-F. Valley, G. Pache et P. Lerch, in Proc. 4th Int. Conf. on Luminescence Dosimetry, Krakow-Poland, Vol. 3, p. 977 (1974)
- (2) J.-F. Valley, G. Pache et P. Lerch, Helv. Phys. Acta 49, p. 171 (1976)

ETUDES DOSIMETRIQUES ET SPECTROMETRIQUES  
DE FAISCEAUX X DE FAIBLES ENERGIES (ENTRE 4 ET 25 keV)

J.L. CHARTIER<sup>+</sup> - A. BAZOGE<sup>++</sup> - C. ITIE<sup>++</sup>

<sup>+</sup> Département de Protection, STEP/STID, Commissariat à l'Energie Atomique, B. P. n°6, 92260 Fontenay-aux-Roses, France.

<sup>++</sup> Laboratoire Central des Industries Electriques, Fontenay-aux-Roses France.

1. INTRODUCTION.

Dans des publications précédentes (1), (2), (3), nous avons montré l'intérêt de la fluorescence X pour certains problèmes liés à la radioprotection et nous avons décrit les moyens de réaliser des faisceaux de rayonnements monochromatiques où le débit d'exposition peut atteindre plusieurs Roentgen/heure. Ces faisceaux, étalonnés en débit d'exposition constituent un outil indispensable à l'étude et la détermination de la courbe de réponse en fonction de l'énergie des dosimètres et débitmètres dans un domaine énergétique où ils affichent généralement de fortes variations de sensibilité (au-dessous de 100 keV). Nous nous proposons :

a/ d'étendre la gamme énergétique des faisceaux disponibles étalonnés vers les basses énergies (jusqu'à 5 keV).

b/ de réaliser des faisceaux étalonnés de faibles débits d'exposition (jusqu'à environ 1 mR/h), destinés à l'étalonnage des bas calibres des débitmètres et l'étude des faibles doses.

2. FAISCEAUX DE RAYONNEMENT X DE FAIBLE ENERGIE - ETALONNAGE.

Alors que la technique de production de ces faisceaux ne pose aucun problème particulier (cible de chrome pour 5,4 keV; cible de germanium pour 9,8 keV; cible de zirconium pour 15,7 keV) des difficultés apparaissent lors de la mesure du débit d'exposition en raison de l'absorption importante du rayonnement dans tout matériau, même de Z faible utilisé dans la construction du dispositif de mesure.

C'est pourquoi, tout en conservant le principe de la chambre MESH, déjà décrite dans (3), nous avons adapté ses caractéristiques aux nouvelles conditions de mesure.





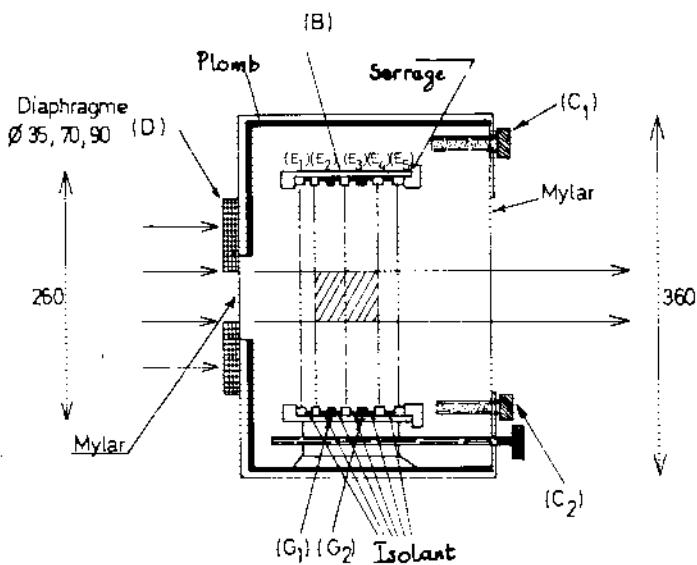
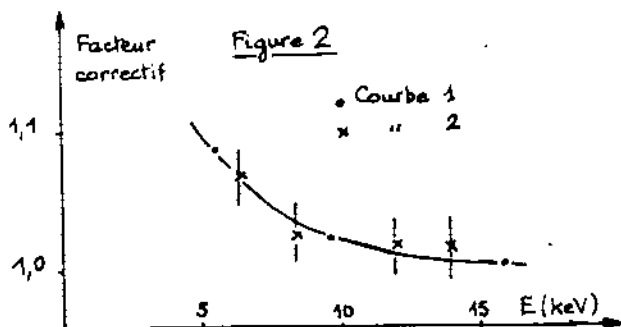

Figure 1

Les modifications ont porté principalement sur :

- a/ la diminution de la masse surfacique des électrodes, abaissée à une valeur comprise entre 3 et 5 mg/cm<sup>2</sup>.
- b/ la diminution de la distance interélectrodes fixée à 6 mm dans le volume de collection.
- c/ la diminution de la distance diaphragme d'entrée - plan de symétrie du volume de collection à 25 mm.

Nous avons entrepris de déterminer expérimentalement le terme correctif dû à l'absorption du rayonnement mesuré dans chaque électrode et dans l'air. Puis en réunissant les résultats obtenus dans chaque cas, nous en avons déduit le facteur de correction permettant de "remonter" à l'exposition au niveau du plan de sortie du diaphragme de la chambre, à partir du courant d'ionisation mesuré. La courbe obtenue est représentée sur la figure 2 (courbe 1).



Il nous a semblé souhaitable de confirmer cette courbe en testant la chambre MESH que nous avons construite sur une installation de référence équipée d'une chambre absolue à plaques parallèles, en l'occurrence celle du L.C.I.E., pour le rayonnement de faible énergie ( $\bar{E} < 30 \text{ keV}$ ). Pour les différentes "qualités" de rayonnement que nous donnons plus loin, nos résultats expérimentaux nous ont conduits à la courbe 2 figure 2. Compte tenu de l'incertitude affectant les mesures, un bon accord est observé entre les 2 tracés dans la zone énergétique : 5 keV - 20 keV

$\bar{E} = 25 \text{ keV}$	H.T. = 30 kV	Filtration totale = 4,13 mm Al
$\bar{E} = 16 \text{ keV}$	H.T. = 20 kV	" " = 1,05 mm Al
$\bar{E} = 12 \text{ keV}$	H.T. = 15 kV	" " = 0,53 mm Al
$\bar{E} = 8,5 \text{ keV}$	H.T. = 10 kV	" " = 0,14 mm Al
$\bar{E} = 6,5 \text{ keV}$	H.T. = 7,5 kV	" " = 0,033 mm Al

Outre les avantages que l'expérience des chambres MESH nous a permis d'observer (facilité d'utilisation en raison d'un grand volume de collection, stabilité dans le temps, courbe de réponse indépendante de l'énergie), ce modèle est caractérisé par un faible courant de fuites :  $\approx 5.10^{-12} \text{ A}$ .

### 3. FAISCEAUX DE REFERENCE DE FAIBLE DEBIT D'EXPOSITION ( $\approx 1 \text{ mR/h}$ )

La réalisation de ces faisceaux est le résultat de 2 programmes complémentaires d'expérimentation.

1° - Il était indispensable de conserver la distribution spectrale du rayonnement produit, définissant le "facteur de pureté" F

$$F = \frac{X_{\text{fluorescence}}}{X_{\text{total}}} \quad X_{\text{total}} = X_{\text{fluo}} + X_{\text{diffusé}}$$

Les différentes mesures nous ont amenés aux conclusions suivantes :

- a/ conservation de la valeur de la haute tension appliquée au tube radio-gène irradiant la cible à la valeur établie dans (1).
- b/ diminution de la surface de la cible à une valeur voisine de  $0,5 \text{ cm}^2$ , complétée par une forte collimation du faisceau primaire.
- c/ distance cible - plan d'irradiation portée à 1 mètre.

2° - L'étalonnage en débit d'exposition du faisceau monochromatique de fluorescence ne peut se faire sans l'utilisation d'un détecteur complémentaire d'une sensibilité adaptée à l'intensité des nouveaux faisceaux. Ce détecteur (NaI(Tl) ou Ge(Li)) utilisé simultanément et en arrière de la chambre MESH placé dans le plan d'irradiation choisie, délivre une information proportionnelle au courant d'ionisation mesuré. Cette information sert alors de transfert pour la détermination de l'exposition dans les conditions expérimentales de faible débit définies au 1°.

Ces études expérimentales ont été mises en oeuvre pour l'ensemble des cibles dont nous disposons et sur la totalité de la gamme énergétique de la fluorescence X (au-dessous de 100 keV) on peut disposer de faisceaux de débits d'exposition voisins de 1 mR/h.

BIBLIOGRAPHIE.

- (1) J.L.CHARTIER, G.PORTAL, D.ROMAN, D.DUCUAY,  
Nucl. Instr. and Methods, 100, 107 - 119 (1972).
- (2) J.L.CHARTIER, D.ROMAN, A.BAZOGE,  
Nucl. Instr. and Methods, 119, 427 - 444 (1972).
- (3) J.L.CHARTIER, A.BAZOGE, C.ITIE,  
Nucl. Instr. and Methods, 128, 251 - 259 (1975).

## THE RELIABILITY USED IN HEALTH PHYSICS INSTRUMENTATION

S. Muždeka, D. Danilović, S. Kostić

Institute of Nuclear Sciences "B. Kidrič",  
Belgrade, Yugoslavia

## 1. INTRODUCTION

As a part of the development of instrumentation using transistors has been the expected improvement in the reliability. Improvements in performance - in particular a considerable reduction in the number of setting up and in situ adjustments and reduction in size have been worth-while goals. In recent years the demand and need for greater reliability assurance in all-solid-state devices continues to grow. Electronic systems continue to grow more complex and often a system failure may have immediate and visible impact. Consumers are demanding better warranties at a time when service costs are rising rapidly. Further, a dynamic solid state technology rapidly generates new devices that offer even greater functional and reliable potential.

## 2. RELIABILITY AND MAINTENANCE IN THE LOGISTICS

More recently, logistics (1) is being viewed as the composite of all considerations necessary to assure the effective and economical support of a system through its programmed life-cycle. It is an integral part of all aspects of system definition, design, development, test and evaluation, production and/or construction, and operational use. In other word, the prime equipment and the element of logistic support must be developed on an integrated basis to produce a cost-effective product.

As an example, individual applicable costs are estimated for each year, totaled, and are projected as a cost profile in Fig.1 (2). It is clear that the activities in the research and development phase can highly decrease the costs for operation and maintenance.

Reliability is the probability that an equipment item will operate in a satisfactory manner for a specified period of time when used under stated conditions (3), and is often expressed in term of MTBF (mean-time-between-failures). The reciprocal of MTBF is the failure rate ( $\lambda$ ), which is a significant factor of corrective maintenance.

Examples of predicting reliability are given in Fig.2. There is a comparative analysis of two types of radiation monitors and two types of digital rate-meters (scaler-timer-h.voltage) developed in the years 1970 and 1976.

The maintenance concept provides the basis for the establishment of supportability requirements in system/equipment design (4). The maintenance concept supplemented by the logistic

support analysis, leads to the identification of maintenance tasks, task frequency and times, personal quantities and skill levels, test and support equipment, spare/repair parts, facilities and other resources.

Major level of maintenance can be divided in three main groups (Fig.3):

- organizational maintenance at the operational site or whenever the prime equipment is located;
- intermediate maintenance performed by mobile, and/or fixed specialized organizations and installations; at this level an item may be repaired by the removal and replacement of major modules, assemblies or parts;
- depot maintenance as the highest type of maintenance.

At each organizational level where corrective maintenance is accomplished one must determine the type and quantity of spare items to be provisioned and stocked. Also, it is necessary to know how often provisioning should be accomplished. Spares required due to system/equipment failure are a function of part reliability and are based on the Poisson distribution. In predicting spare parts quantities, one should consider the level of protection desired (safety factor).

In Fig.4 is given a list of spare/repair parts for the optimization (5).

### 3. CONCLUSION

The future of electronics lies in the full development of microelectronics and optoelectronics. Microelectronic will broaden the use of microcomputers, at a reasonable low cost for process control, for data collection, life test and for all routine work. Low costs will allow multiple redundancy and raise reliability levels to "fit-and-forget", thus further increasing possible applications.

### REFERENCES

- (1) Blanchard, B.S.: "Logistics Engineering and Management", Prentice-Hall Inc., New Jersey, 1974.
- (2) Muždeka S.: "Environmental Monitoring", III International Summer School on Radiation Protection", Herceg Novi, 1976.
- (3) Dombrowski, E.: "Einführung in die Zuverlässigkeit elektronischer Geräte und Systeme, AEG - Telefunken, Berlin, 1970.
- (4) Guyot, C.: "Initiation a la maintenabilité", Dinod, Paris, 1969.
- (5) Messinger, M. and Shooman, M.L.: "Techniques for Optimum Spares Allocation: A tutorial review", IEEE Trans. on Reliability, Vol. R-19, No.4, Nov. 1970.

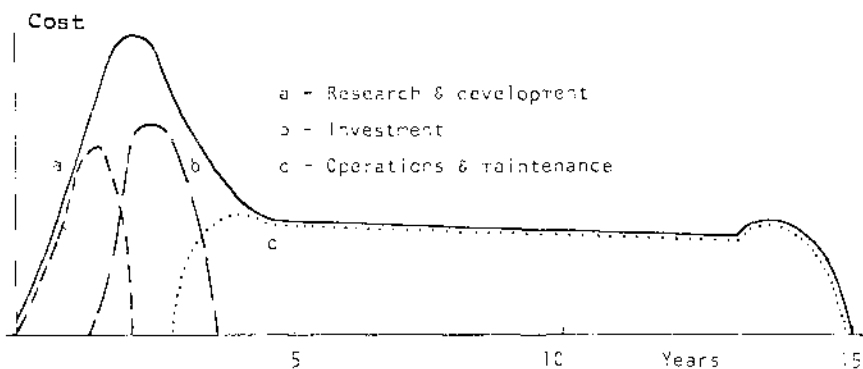

Fig. 1. Cost Profile of System/Equipment Life-cycle

Type of instr.	Group of compon.	Failure rate, $\lambda_{ei}$ [ $10^{-6}/h$ ]	MTBF [hours]
Monitor $\beta/\gamma$ (with tubes)	R	24	7.800
	C	15	
	AE	80	
	O	9	
	T	128	
Monitor $\beta/\gamma$ (semiconductors)	R	6	27.800
	C	6	
	AE	20	
	O	4	
	T	36	
Digital rate-meter (year 1970)	R	9	21.740
	C	4	
	AE	20	
	O	13	
	T	46	
Digital rate-meter (year 1976)	R	6	35.500
	C	0,2	
	AE	15	
	O	7	
	T	28,2	
R - resistors		O - others	
C - capacitors		T - total	
A - active elements			

Fig. 2. Comparative Analysis of Predicting Reliability of Several Health Physics Equipments.

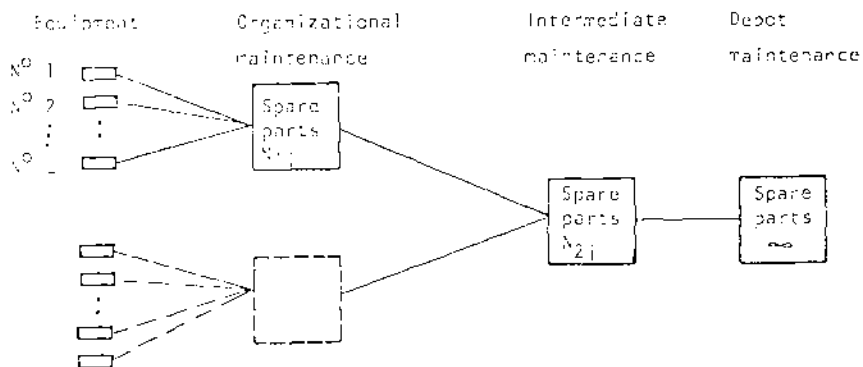

Fig.3. Levels of Maintenance

```

*****
* ITEM * NUMB. * LAMBDA * COMP. * NUMBER OF EQUIPMENT *
* N1. * COMP. * (1/H) * COST * 20 * 100 *
* (J) * R(J) * L(J) * C(J) * N1(J) * N2(J) * N1(J) * N2(J) *
*****
*
*
* 67 * 1 * 1.2-006 * 500 * 1 * 0 * 2 * 1 *
* 68 * 1 * 3.0-007 * 200 * 0 * 1 * 0 * 3 *
*
* 70 * 1 * 5.0-007 * 530 * 1 * 0 * 3 * 0 *
* 71 * 1 * 1.4-006 * 20 * 2 * 0 * 3 * 1 *
*
* 73 * 2 * 6.8-007 * 40 * 2 * 0 * 2 * 1 *
*
*****
  
```

Fig.4. List of Optimized Spare/Repair Parts

A NEW INSTRUMENT FOR QUICK DETERMINATION  
OF RADON AND RADON-DAUGHTER CONCENTRATIONS  
IN AIR. CONCEPT, ANALYTICAL BASIS, CALIBRATION  
CAVEATS, THE EMBODIMENT AND FIELD RESULTS.

J. D. Shreve, Jr.,  
Kerr-McGee Corporation  
Oklahoma City, Oklahoma

Robert W. Miller  
MDA Scientific, Inc.  
Park Ridge, Illinois

James E. Cleveland  
Kerr-McGee Nuclear Corporation  
Grants, New Mexico

Background

That the sum of alpha ( $\alpha$ ) and beta ( $\beta$ ) activities from radon daughters collected on a filter is roughly proportional to working level (WL) was first noted by Hill (1,2), just a few months after he had participated in the field trials of two versions of the MIT Instant Working Level Meter (3,4) both of which proved undependable for in-mine determinations.(5)

Hill asked Shreve (1,2) to evaluate the idea independently. This led to prompt confirmation; whereat, Hill modified existing instruments to try the concept as Shreve engaged in analytical work to explore extentions he sensed were implicit in the concept. Setting a goal of 4 minutes or less for a complete measurement cycle, a 2-min sampling time was elected with an effective decay time of 1 min (counting done from 30 sec to 1 1/2 min after sampling), 3.5 min in all.

Early Computations

The left side of Table 1 reproduces one early set of computations (6). The right side is a parallel expectation were the same filter recounted at a decay time of 5 min, i.e., with a 30 sec. delay, instrument recycling gives a second WL value.

Ingrowth Working		Remaining Activities (dpm) on Filter from 2-minute Sampling @ 2.5l/min and											
		Decay Time = 1 min.						Decay Time = 5 min.					
Time	Level	Total Total ( $\alpha+\beta$ )									Total Total ( $\alpha+\beta$ )		
Min	WL	RaA	RaB	RaC(C')	$\alpha/\beta$	$\alpha+\beta$	WL	RaA	RaB	RaC(C')	$\alpha/\beta$	$\alpha+\beta$	WL
6	0.113	528	104	12	540/ 116	656	5805	212	128	26	238/ 154	392	3469
12	0.198	665	232	45	710/ 277	987	4985	267	151	71	338/ 312	660	3333
20	0.300	703	390	115	818/ 305	1323	4410	283	398	152	435/ 550	985	3283
30	0.414	710	551	223	933/ 774	1707	4123	285	544	267	552/ 811	1363	3292
45	0.560	710	726	407	1117/ 1133	2250	4018	285	703	448	733/ 1151	1884	3364
60	0.672	710	845	571	1281/ 1416	2697	4013	285	810	605	890/ 1415	2305	3430
70	0.826	710	980	815	1525/ 1795	3320	4019	285	932	834	1119/ 1766	2885	3493
120	0.903	710	1044	958	1668/ 2002	3670	4054	285	990	976	1261/ 1966	3227	3574
Equil.	1.000	710	1096	1118	1828/ 2214	4042	4042	285	1037	1109	1294/ 2246	3540	3540

TABLE 1 IWLM Foundation Data. Radon-Daughter Collections from Air with 100 pCi/l of Radon as a function of age.

Age of Air Correction

In that 20 min of radon ingrowth was thought the most common situation in uranium mines,  $\alpha+\beta = 4400$  dpm was chosen as the reference condition. For ingrowth times less than 20 min filters would overcount; 'older air' would undercount.(6) Note, too, in Table 1, the decrease in  $\alpha/\beta$  with increasing air age. At once,  $\alpha/\beta$  was recognized as an age of air correlate. Thus, errors inherent to the method can be corrected as Figure 1 sets forth. Raw second WL observations, multiplied by



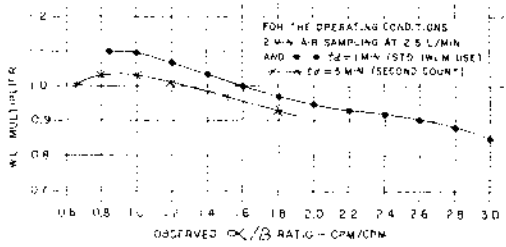

Figure 1 - WL Correction via  $\alpha/\beta$

Instrument Design Features

The ultimate embodiment of these ideas - the product of two, extensively tested prototypes - employs opposed  $\alpha$  and  $\beta$  detectors that adjoin a common slot into which the air filter is placed for counting after the 2-min air sampling; it measures 2 3/4 x 8 1/2 x 10 1/2 in. and weighs 11 pounds. Detectors and slot are within a steel shield to suppress  $\gamma$ -induced signals. Background is measured during sampling and subtracted during filter counting. An outside pump with hose and filter holder is required. The instrument, now marketed worldwide on a license from Kerr-McGee Nuclear Corporation by MDA Scientific Inc., Park Ridge, Illinois, USA, as Model 811 Instant Working Level Meter (7), is pictured in Figure 3.

About 40 WL determinations can be made by judicious instrument use on one full battery charge. Where high grade ore is mined and  $\gamma$  background exceeds 1mR/hr, a tungsten shield can be substituted for the steel.

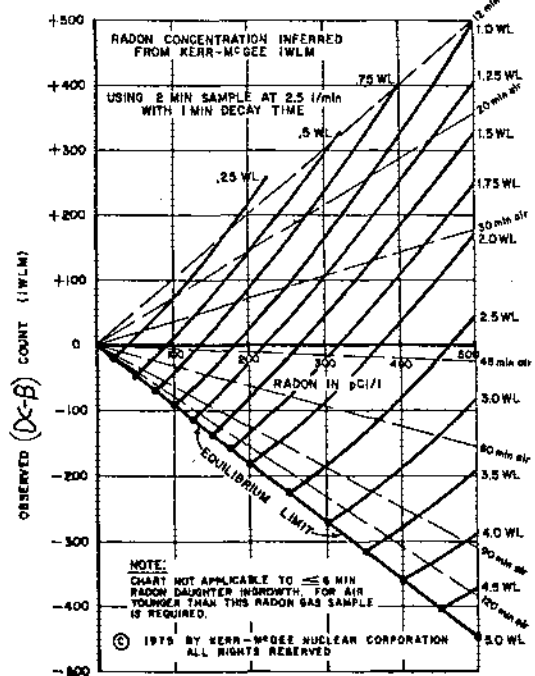

Figure 2 - Radon Inference Scheme

1.3 in accord with Table 1, are less prone to error.

Radon Inference

With  $\alpha$  and  $\beta$  activities measured separately, approximation of radon concentration is possible knowing  $\alpha$  minus  $\beta$  and WL. The scheme is shown in Figure 2. The radon concentration lies below the intersection of observed  $\alpha$ - $\beta$  and the appropriate WL curve.



Figure 3 - IWLM in Use

Calibration

a. General Conditions - Striving for maximal usefulness, the design was directed toward having 1.00 WL (4400 dpm) correspond to  $\alpha$ - $\beta$  = 1000 cpm. Fixing the decimal point propitiously caused the  $\alpha$  and  $\beta$  displays (LED type) to read the WL

level each contributes. Their sum, is the WL. Their ratio and difference, serve in age of air correction and radon inference.

b. General Counting Problems - Alpha counting of filters always suffers from absorption to some degree. Beta-active, short-lived radon-daughters emit  $\gamma$  rays, and alternately, internally convert potential  $\nu$ 's to monoenergetic groups of swift electrons, indistinguishable from the  $\beta$  emissions to the detector. Moreover,  $\beta$  scintillators normally give much less light per particle than does ZnS stimulated by  $\alpha$ -particles. In addition,  $\beta$  scintillators are both gamma and alpha sensitive.

c. Standard Sources-Size and Activity Discrepancies - Source size can be a real concern in the close, small angle, detector-source geometry commonly employed in filter counting (8,9,10,11). Calculations made for the IWM are instructive (12). IWM detector apertures are flared nominally from 0.75 in. at 35° to raise the  $\beta$  count without increasing  $\nu$  background. Efficiencies computed for sources with different circular, active areas for the flared aperture and a straight-sided one 0.750 inches in diameter are given in Table 2. The ideal is a calibration source identical in area and shape to the exposed part of the filter (0.75 in.). Uniform activity distribution is imperative. Finally, the active surfaces of source and sample must be positioned identically with respect to the detector.

Active Spot Diameter (in.)	Counting Efficiency %	
	Straight Aperture	Flared Aperture
4 (.157)	33.6	39.2
8 (.314)	32.6	35.5
12 (.472)	30.7	37.0
16 (.630)	28.0	35.0
19 (.750)	25.6	32.5

Daughter Ingrowth Time (min)	Filter Activity at $t_d = 1$ min			Count Ratio RaB/RaC	Count Excess % of Total $\beta$	Potential Error In WL %
	RaA dpm	RaB $\beta$ dpm	RaC $\beta$ dpm			
6	528	104	12	8.67	20.7	+3.7
12	665	232	45	5.16	19.4	+5.7
20	703	390	115	3.39	18.1*	+7.6
30	710	551	223	2.47	16.7	+8.7
60	710	815	571	1.48	14.3	+9.5
Equil.	710	1095	1118	0.98	12.2	+9.2

Table 2 - Source-Size Effects      Table 3 Age of Air,  $\beta$ -Count Excess, and WL Errors

d. Standard Sources - Spectral Differences and Extra Emissions - Well made  $\alpha$  sources are crucial. The usual  $\alpha$  long-lived emitters cannot match the 6.0 mev and 7.68 mev of RaA and RaC'. Further, filters undercount 3 to 10% due to particle embedment; lower percentage applies to RaC', upper to RaA. Filter material and air flow rate are obvious factors. The 2.5l/min specified for the Model 811 lessens this effect. Yet, the larger dependence of the IWM upon RaA  $\alpha$ 's, spells a count defect of about 5 to 8%, less in dry mines than in damp mines.

The problems of  $\beta$  counting are many and elusive. Here again,  $\beta$  characteristics of standard sources cannot duplicate those of RaB and RaC. Too,  $^{90}\text{Sr}-^{90}\text{Y}$  is  $\gamma$ -free and has no conversion elections. And ratio of RaB to RaC varies as average age of air changes. Nevertheless, with proper study of the several factors, the advantages of doing beta counting along with alpha counting outweigh the uncertainties.

e. Correction Factors - Major  $\beta$ -counting problems and their solutions follow:

- Beta backscatter from standard sources on metal discs raises  $\beta$  count 12 to 15% above normal. Solution: Use scatterless sources.
- Supernumerary counts from conversion electron are estimated (13) to be 23% of RaB  $\beta$  activity but only 1.6% for RaC. Table 3 associates this effect with age of air, corresponding a activity and potential WL error. Solution: Correct to the 18.1% level starred, (air age 20 min.). Allow for 3% overcount from  $\gamma$  rays emitted by RaB and RaC. Overall, a 21% correction is indicated.
- Some 10% of the  $\beta$  counts are missed by thinning the Pilot B from 0.125 - to 0.020-in. to reduce  $\gamma$ -response. Even energetic  $\beta$ 's entering the scintillator

at nearly normal incidence generate electrical pulses which fall below the signal level discriminator. Comparing counts from a  $\beta$  source with Pilot B thicknesses of 0.020, 0.063 and 0.125-in. permitted quantification of the effect. Fortunately, increasing amplifier gain and discriminator level keeps the effect about 9%.

4. The  $\alpha$ -sensitivity of Pilot B is countered by absorption in the filter and in the aluminum foil (.0008-in. thick) which covers the Pilot B a light-tight barrier. Aluminized mylar ( $\approx 1\text{mg}/\text{cm}^2$ ) covers the ZnS.

f. Alpha-Beta Additivity - Final Calibration Scheme - From the introductory section it is clear that both  $\alpha$  and  $\beta$  activity must be counted at a net efficiency of 22.7% - 1000cpm/4400dpm. Given that the  $\alpha$  counting suffers 6% from self absorption in the filter; an  $\alpha$  standard must count at 24.4% of its dpm rating.

When all extraneous  $\beta$  counting influences are melded into a single corrective factor, a scatterless Sr-Y source with activity spread evenly in a 16mm diameter circle should read 21.8% of its activity expressed in dpm. Actual, in-mine tests of the IWLM indicate that  $\beta$  calibration as low as 20% is acceptable.

g. Comparative Field Tests - Some 6 to 14 instruments have been in daily use in seven Kerr-McGee, underground mines in New Mexico for more than a year. Even so, an independent evaluation was requested of the U. S. Mining Enforcement and Safety Agency (MESA) and Bureau of Mines Research Center (Denver, Colorado) to find the Model 811 IWLM satisfactory for all in-mine requirements for radon-daughter monitoring.

Table 4 summarizes the data collected from January 17 through 19, 1977 at the Twilight Mine (Uravan, Colorado) by personnel from the MESA, the BuMines Research Center, MDA Scientific, Inc. and Kerr-McGee Nuclear Corporation

Mine Location	Tsivoglou			Model 811 IWLM			Kusnetz		
	Ave. Obs.	No. of Rdgs.	One Std. Dev.	Ave. Obs.	No. of Rdgs.	One Std. Dev.	Ave. Obs.	No. of Rdgs.	One Std. Dev.
	WL	Rdgs.	Dev.	WL	Rdgs.	Dev.	WL	Rdgs.	Dev.
Closed Chamber	4.69	8	0.072	4.80	20	0.045	5.48	19	0.111
Air Cleaning Station	0.43	5	0.012	0.41	18	0.017	0.46	15	0.018
Haulageway	0.172	6	0.011	0.195	29	0.0038	0.196	23	0.008

Table 4 - Cross-Comparison of WL Measurements by the Methods of Tsivoglou, Kusnetz and the Model 811 IWLM. January 1977.

h. Conclusions - The Model 811 IWLM, calibrated in the fashion described, can provide WL assessments at least equivalent to those from Kusnetz determinations in 3.5 min plus a confirmatory measurement in a total elapsed time of 7.5 min including sampling. Approximation of  $\gamma$  field intensity and radon gas concentration are bonus data. It enables more thorough mine coverage, quicker diagnosis and correction of ventilation problems, reduction of radiation exposure of miners and more efficient use of monitoring personnel.

No instrument of comparable characteristics is obtainable in the world today to the knowledge of the authors. It is the product of an idea supported by the harmony of analysis, engineering design and intensive testing.

#### REFERENCES

- (1) SHREVE, J.D., Jr., TROWSDALE, L.S., HILL, A., "Method and Apparatus For Indicating The Radioactive Decay Products of Radium In An Environment". U.S. Pat. 3,988,587, issued Oct. 26, 1976.
- (2) HILL, A., CLEVELAND, J.E., SHREVE, J.E., Private Communications from Sept.-Dec. 1971.
- (3) SHREVE, J.D., Jr., Protection of Workers in Radon-Rich Atmospheres: The

Mandate for Quick Determination of Radon-Daughter Concentrations and a Solution, Specialists Mtg. on Personal Dosimetry and Area Monitoring Suitable for Radon and Daughter Products, Elliot Lake, Ont. Ca., 4-8 Oct. 1976, NEA of OECD, Paris, Fr.

- (4) SCHROEDER, G.L., EVANS, R.D., Some Basic Concepts in Uranium Mine Ventilation, Radium and Mesothorium Poisoning and Dosimetry and Instrumentation Techniques in applied Radioactivity, An. Prog. Rpt., Mass. Inst. of Tech., MIT-952-5 (1968), and MIT-952-6 (1969).
- (5) BRESLIN, A.J., SHREVE, J.D., Private Communication with AEC Health and Safety Laboratory N.Y., N.Y. Dec. 1971.
- (6) EVANS, R.D., Engineers' Guide to The Elementary Behaviour of Radon Daughters, Health Physics, 17 2 (1969).
- (7) MILLER, R.W. et al, A New Monitoring Technique for Airborne Radon Daughters, Health Physics, Soc. Ninth Midyear Top. Symp., Denver, Colo., Feb. 9-12, 1976.
- (8) KUSNETZ, H.L., Radon Daughters in Mine Atmospheres - A Field Method for Determining Concentrations, Ind. Hyg. Qtrly, (Mar. 1956).
- (9) TSIVOGLIOU, E.C., et al, Occurrence of Nonequilibrium Atmospheric Mixtures of Radon and Its Daughters, Nucleonics 11 (1953).
- (10) ROLLE, R., Determination of Radon Daughters on Filters by a Simple Liquid Scintillation Technique, AIHAJ, (Nov.-Dec. 1970).
- (11) HILL, A., Rapid Measurement of Radon, Decay Products, Unattached Fractions, and Working Level Values of Mine Atmospheres, Health Physics, 28 4 (1975).
- (12) SHREVE, J.D., Jr., Computing the True Counting Geometry of Extended Sources in Planar Systems, to be published.
- (13) LEDERER, C.M., et al, Table of Isotopes, Sixth Edition, Wiley, N.Y. (1967).

ENSEMBLE DE MESURE PORTATIF AUTOMATIQUE DESTINE A LA MESURE  
DIRECTE DE LA CONCENTRATION DE  $R_a A$ ,  $R_a B$  et  $R_a C$  DANS UNE MINE D'URANIUM

R. CHUITON\* - PH. DUPORT\*\* - R. PRIGENT\* - P. SAJAROFF\*\*\*

\*Département de Protection, STEP/ST10, Commissariat à l'Energie  
Atomique - B.P. N° 6 - 92260 FONTENAY-aux-ROSES - France -

\*\*Département de Protection, STEP/PAM, Commissariat à l'Energie  
Atomique - B.P. N° 3 - 87640 RAZES, Division de la Crouzille-France-

\*\*\*Comisión Nacional de Energia Atomica, Avenue Libertador 8250,  
BUENOS-AIRES - Argentine -

1. BUT

L'appareil décrit est un ensemble électronique micro-programmé par "hardware" qui permet la détermination directe de la concentration en  $R_a A$ ,  $R_a B$  et  $R_a C$  de l'air en picocurie par litre d'air (pCi/L).

La méthode (1) et (2) consiste à effectuer un comptage  $\alpha$  après prélèvement de l'air sur un filtre pendant trois temps de comptage différents séparés par des intervalles de temps différents. Le diagramme des temps est présenté par la figure suivante :

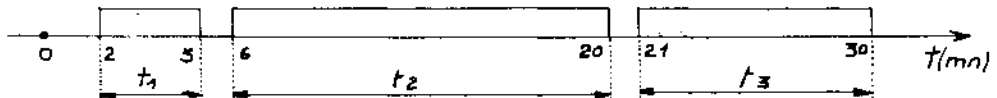

$t_1$ ,  $t_2$  et  $t_3$  sont les 3 temps de comptage.

Compte tenu du bruit de fond de l'ensemble de détection, de l'efficacité de la détection, de la vitesse d'aspiration de l'air et de la durée de prélèvement de l'échantillon à analyser, on peut calculer directement la concentration des 3 radionucléides à partir des équations suivantes :

$$C_{R_a A} = (0,16894 N_{2-5} - 0,082 N_{6-20} + 0,07753 N_{21-30}) \cdot \frac{2}{d}$$

$$C_{R_a B} = (0,00122 N_{2-5} - 0,02057 N_{6-20} + 0,04909 N_{21-30}) \cdot \frac{2}{d}$$

$$C_{R_a C} = (-0,02252 N_{2-5} + 0,03318 N_{6-20} - 0,03771 N_{21-30}) \cdot \frac{2}{d}$$

avec :

$C_{R_a i}$  : concentration du radionucléide  $i$  en pCi/L

$N_{i,j}$  : nombre d'impulsions pendant les minutes  $i$  à  $j$

$d$  : débit d'aspiration de l'air en L/mn

Le but de cet ensemble électronique est de résoudre d'une façon automatique les trois équations précédentes à partir des coefficients constants donnés et de pouvoir, si on le désire, de changer la valeur de ces coefficients à partir d'un clavier de commande.

## 2. DESCRIPTION DE L'ENSEMBLE ELECTRONIQUE.

La détection des particules alpha est effectuée d'une façon classique à l'aide d'un scintillateur associé à un photomultiplicateur.

Les impulsions de sortie sont amplifiées et mises en forme avant d'être stockées dans trois échelles de comptage qui mettent en mémoire les valeurs  $N_{2-5}$ ,  $N_{6-20}$  et  $N_{21-30}$ .

Parallèlement ces impulsions sont envoyées vers une autre échelle de comptage de capacité  $10^6$ . Cette dernière voit chaque décade balayée par un circuit multiplexeur afin de transmettre son contenu dans la mémoire du circuit calculateur. Ce même circuit multiplexeur permet d'une part de stocker en mémoire les coefficients constants de chaque équation et réalise d'autre part le déroulement du programme de calcul.

Un circuit "horloge" interne permet de programmer les temps d'arrêt et de comptage.

La commande des circuits calculateurs est effectuée à l'aide de porte bidirectionnelle de la famille "C-MOS" ce qui permet la mise en parallèle de systèmes différents sans être gênés par les impédances différentes.

Dans cet ensemble la division de chaque équation par le débit d'aspiration "d" est effectuée par le circuit multiplexeur. Cette valeur "d" peut être choisie par l'opérateur à partir de roues codeuses du type "contraves".

## REFERENCES

- (1) "Measurement of radon daughters in air", JESS.W.THOMAS, HEALTH PHYSICS VOL. 23, 783-789, 1972.
- (2) "Comparaison de quelques méthodes de contrôle du radon et de ses descendants dans les mines d'uranium", Danilo HAJDUKOVIC, Ph., DUPONT, Publication interne CEA-STEP/FAR.

ON THE POSSIBILITY OF THE DOSE FORMATION STUDY BY  
MEANS OF ČERENKOV RADIATION

K.A. Trukhanov, V.N. Grebenev, V.N. Schlapak

The Institute of Medical-Biological Problems, Moscow

## 1. INTRODUCTION

For better insight into the processes of depth-dose distribution it is necessary to realize in detail the energy distributions of primary and secondary charged particles fluxes in the irradiated matter. As a rule, these distributions are determined theoretically, e.g. by solving of Boltzman transport equation or Monte-Carlo calculation. As regards the experimental data is hardly available since the existing methods are only adequate in the case of heavy particles, have a limited range of validity and a low resolution. For this reason it is hard to verify in detail the accuracy of the calculations and to obtain the independent information. It is suggested to obtain the energy distribution of particles on the intensity and angular distribution of Čerenkov radiation which is emitted from the small radiator inserted into the irradiated matter at the point of interest. It should be noted that the well known methods in high-energy physics based on the use of Čerenkov radiation allow to determine only the average velocity of fast charged particles for the nondirectional beam (1,2).

## 2. DESCRIPTION OF THE METHOD

A fairly thin plane-parallel Čerenkov radiator  $d$  thick is assumed to be located in the irradiated matter. Its position will be characterized by means of coordinate  $Z$ . Cartesian coordinate system  $X'Y'Z'$  is introduced so that the plane  $X'Y'$  is coincided with the front surface of the radiator and the  $O'Z'$ -axis is the normal to that surface. The direction of charged particles motion is given by polar and azimuthal angles  $\vartheta_p$  and  $\varphi_p$  and the sense of photon emission is given by angles  $\vartheta_e$  and  $\varphi_e$ . The distribution of particles on the front surface of radiator is assumed to be independent of coordinates  $X'Y'$  and is given by function  $f(Z'=0, \beta, \vartheta_p, \varphi_p)$ , where  $\beta$  is the velocity of the particles in units of speed of light.

The number of photons emitted with frequency  $\nu$  in the interval  $\Delta\nu$  per unit length traversed by a particle of charge  $ze$  is given by (3)

$$\frac{dN}{dz} = 2\pi d z'^2 \frac{\Delta\nu}{c} (1 - 1/n^2\beta^2) \quad (1)$$

where  $\alpha = \frac{1}{137}$  - is the fine structure constant;

$n$  - is the absolute index of refraction.

This expression assumes that the medium is non-dispersive, that is, the index of refraction is assumed to be constant over the frequency interval  $\Delta\nu$  of emitted light. Then the number of photons emitted in the given direction within the

boundaries of the radiator is determined by the expression:

$$\frac{d}{d\Omega_R} N(n, Z, \vartheta_R, \varphi_R) = \frac{\Delta V}{c} \alpha d \int_{1/n}^{\beta_{max}} [1 - 1/n^2 \beta^2] \int_0^\pi \sin \vartheta_p d\vartheta_p \int_0^{2\pi} d\varphi_p f(z=0, \beta, \vartheta_p) \delta(\mu_0 - 1/\beta n) \quad (2)$$

where  $\beta_{max}$  is the maximum velocity of particles;  $\mu_0 = \cos \theta$ ;  $\theta$  - is the angle of photon emission with respect to the particle motion direction. The occurrence of Dirac delta function reflects the fact that the particles emit the photons only at the strictly definite angle  $\theta$ , which is given by expression:

$$\theta = \arccos(\beta n) \quad (3)$$

Equation (2) has been derived on the assumption that the variation of distribution function within the boundaries of the radiator can be neglected.

For the calculation of dose distribution it is essential to know the energy distribution at the points of interest. Therefore we have confined ourselves to its obtaining, although the angular distribution of particles can be also found from the angular distribution and the value of Čerenkov flux. Integrating the expression (2) over all directions of photon emission we obtain the integral relation, which connects the total flux of Čerenkov radiation and the velocity distribution of particles

$$N(n, Z) = A \int_{1/n}^{\beta_{max}} (1 - 1/n^2 \beta^2) f(z=0, \beta) d\beta \quad (4)$$

where

$$A = 2\pi Z^2 \frac{\Delta V}{c} \alpha d; f(z=0, \beta) = \int_0^{2\pi} d\varphi_p \int_0^\pi \sin \vartheta_p f(z=0, \beta, \vartheta_p, \varphi_p) d\vartheta_p$$

The expression (4) is the Volterra integral equation of first kind, where  $N(n, Z)$  is the measured experimental value. The solution to this equation is

$$f(z=0, \beta) = \frac{n'^2}{2A} \left[ 3 \frac{d}{dn} N(n', Z) + n' \frac{d^2}{dn^2} N(n', Z) \right] \quad (5)$$

where  $n' = \frac{1}{\beta}$ .

In the choice of the solution procedure it must be born in mind that the equation (4) is not well posed as with the most nuclear spectrometry problems.

The obtaining of the value  $N(n, Z)$  resolves itself into the variation of  $n$  (e.g., by replacement of radiator) and the shift of the radiator inside of irradiated matter. It should be noted that the integral equation (4) and its so-



lution (5) are correct also in the case, when the size of radiator is equal or greater than the lateral dimensions of irradiated region.

With the monidirectional particle beam of known direction of motion, the simple relation is obtained from expression (2), connecting the angular distribution of Čerenkov radiation and the velocity distribution of particles. If the normal to the surface of Čerenkov radiator is coincided with the direction of particle motion, i.e.

$$f(\mathbf{z}'=0, \beta, \vartheta_p, \varphi_p) = B(\beta) \delta(\vartheta_p) \delta(\varphi_p)$$

then

$$B\left(\beta = \frac{1}{\mu_R n}\right) = \frac{T(n, \vartheta_R) n}{A\left(\frac{1}{\mu_R^2} - 1\right)} \frac{d}{d\Omega_R} N(n, z, \vartheta_R, \varphi_R)$$

where  $T(n, \vartheta_R)$  is a coefficient which takes into account the dependence of Čerenkov radiation flux emerged from the radiator on the angle of incidence on the boundary between the radiator and medium,  $\mu_R = \cos \vartheta_R$

### 3. THE FIELD OF APPLICATION

As it was noted above, with the given function  $f(\mathbf{z}, \beta)$ , the dose formation process can be investigated in more detail. With electron or positron radiation (including secondary particles) the production threshold of Čerenkov radiation is reasonably low (e.g., for the medium with  $n \approx 2.4$  it is about 60-50 KeV). This method allows for the energy distributions to be determined and the functional to be calculated from them over a wide range of energy. In the case of heavy charged particles these possibilities become somewhat fewer due to the more complicated interpretation of the results because of the secondary charged particle generation and the more high production thresholds of Čerenkov radiation.

This method is especially convenient for the high energy and intensive fluxes. This fact allows it to be used for the accelerator beam dosimetry, spectrometry and monitoring.

### REFERENCES

- (1) Bhiday M.R., Jennings R.E., Kalmus P.I.P., Measurement of electron beam energy using a gas Čerenkov detector, Proc. Phys. Soc. 72 468 (1958) 973
- (2) Almedia C.E., Almond P.R., Phys. Med. and Biol. 19 4 (1974) 476
- (3) Zrelov V.P., Čerenkov radiation and its application in high energy physics, v. 1, Atomizdat, Moscow (1968)

## A CURRENT-TO-FREQUENCY ELECTROMETER CONVERTER

M.V.Šobajić

Institute of Nuclear Sciences "Boris Kidrič",  
Beograd - Yugoslavia

## 1. INTRODUCTION

The dose rate and dose measurements by using the ionization chambers as radiation detectors request the use of electrometer circuits for low current measurements. The most of existing solutions use electrometer operational amplifiers, high resistance resistors and electromechanical relays of high insulation (for change of the measuring ranges). For the purpose of automation of measurements the obtained dc voltages can be converted to frequency using analog to digital convertes. Few years ago several types of circuits for immediate current to frequency conversion were developed without using high resistance resistors (1-4). The operating principle common for the most of these circuits is that the voltage across an integrating capacitor is controlled by an electrometer amplifier, the output of which triggers a comparator at a determined voltage level. The comparator generates a reset pulse which removes a fixed charge from the integrating capacitor and gives a signal to digital indicator. To remove the charge the following switching elements can be used: electromechanical relays, diodes, bipolar transistors or field effect transistors. For the conversion of extremely low currents the best results are obtained with the use of electromechanical relays. For the conversion of currents in the range of a few decades, higher than  $10^{-12}$ A, the most suitable are bipolar transistors as switching elements. The basic problem in these solutions is temperature instability of bipolar transistors characteristics.

In this paper a new solution is proposed for low current to frequency conversion. For the first time matched pair of encapsulated transistors have been used as switching elements. Thanks to the use of two elements of the same characteristics it has been achieved that the switching elements became practically insensitive to the temperature variation and remained extremely low leakage current. A circuit for current to frequency conversion covering five decades, from  $10^{-12}$ A to  $10^{-7}$ A, has been realized.

## 2. CONVERTER CIRCUIT DESCRIPTION

## 2.1. General description

Block diagram of the proposed converter, on which are given only the elements essential for explanation of the circuit operation, is shown in Fig.1. The integrating capacitor  $C_1$  is connected in the negative feedback of operational amplifier  $A_1$ . This capacitor is discharged by current  $I_{CH}$  from ionization chamber CH and is charged by collector current pulse of transistor  $T_{r1}$  having constant amplitude  $I_{C1}$  and constant duration  $T_1$ . The voltage waveforms at the output of the amplifiers  $A_1$

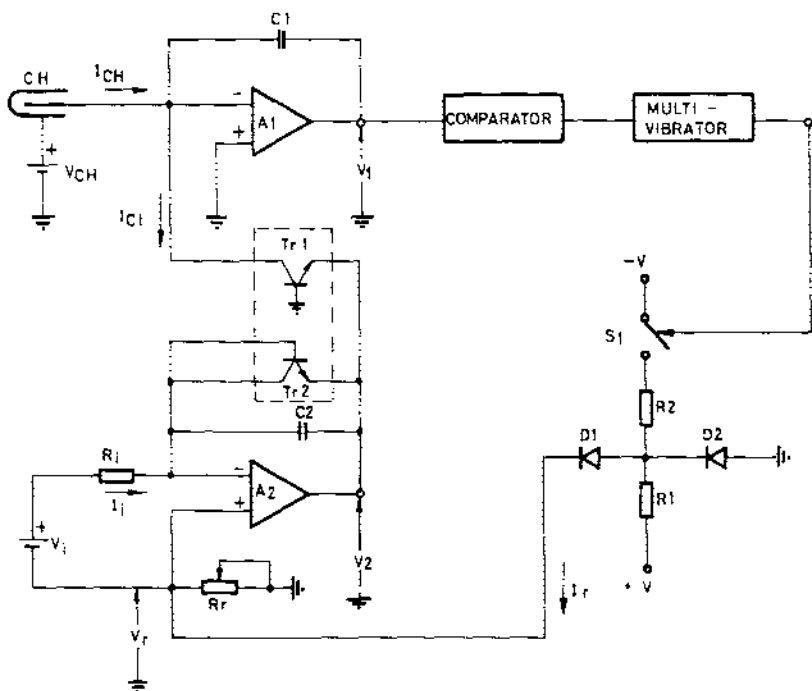

FIG. 1 CONVERTER BLOCK DIAGRAM

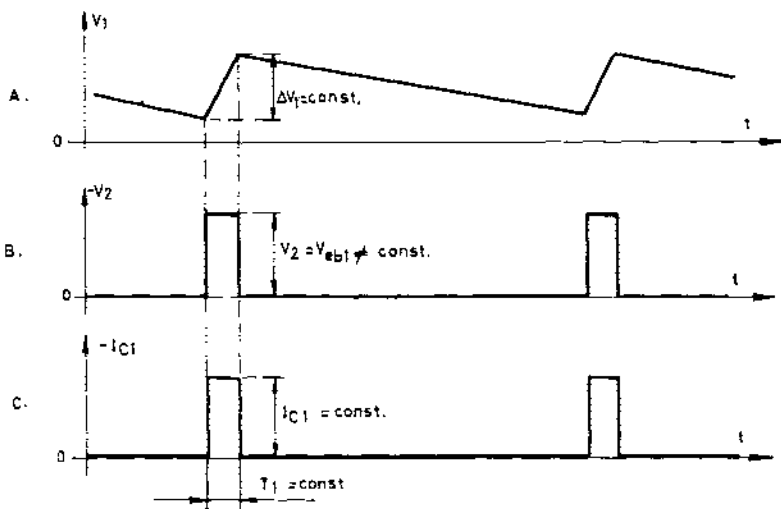

FIG. 2 AMPLIFIERS OUTPUT VOLTAGES AND CAPACITOR CHARGE CURRENT VS TIME

and  $A_2$  are shown in Figs. 2.A. and 2.B., respectively. The current waveforms,  $I_{C1}$ , of the collector of transistor  $T_{r1}$  is shown in Fig.2.C. In the process of conversion there are two different state:

State I: Switch  $S_1$  is off, the amplifier  $A_2$  output voltage  $v_2 = v_{eb1} = 0$ , collector current  $I_{C1} = 0$ ; In this state the current from ionization chamber discharges integrating capacitor.

State II: Switch  $S_1$  is on, the amplifier  $A_2$  output voltage  $v_2 = v_{eb1} = v_{eb2}$ , collector current  $I_{C1} = V_1/R_1$ ; In this state integrating capacitor is charged by collector current of transistor  $T_{r1}$ .

If we observe the time interval in state I (Fig.2.A.) it can be seen that current from the ionization chamber discharges the integrating capacitor  $C_1$  to the level determined by comparator connected to the amplifier  $A_1$ . Then, one shot multivibrator gives at its output the voltage pulse of constant duration  $T_1$ . This pulse switches on  $S_1$  and the circuit passes to state II. In this state the integrating capacitor is charged with the current pulse  $I_{C1}$  of the constant amplitude and duration (Fig.2.C.). After completion of voltage pulse from one shot multivibrator, the switch  $S_1$  is off, the current pulse becomes zero, and the circuit passes again to state I. Thus one cycle of conversion is completed and the other one started.

There is also a special circuit (not shown in Fig.1) which resets the integrator in the case of high input currents when the current pulse  $I_{C1}$  is not sufficient for resetting.

## 2.2. Switching elements operation

The dual matched transistors  $T_{r1}$  and  $T_{r2}$  and general purpose analog switch  $S_1$  are used as switching elements. Grounded base transistor  $T_{r1}$  is connected to the input circuit of electrometer amplifier. Since the collector of this transistor is virtually grounded the leakage current from base to collector is extremely low. In the condition of constant temperature it is possible to produce collector current pulses of constant amplitude by applying voltage pulses of constant amplitude between the base and the emitter. In the condition of variable temperature, to realize the current pulses of constant amplitude as the voltage base-emitter varies with temperature, the amplitude of applied voltage pulses should vary accordingly. In the proposed solution it is achieved by transistor  $T_{r2}$  which is in the same case as transistor  $T_{r1}$ , and therefore at approximately the same temperature. Transistor  $T_{r2}$  with short collected base and collector is connected in the negative feedback of  $A_2$  amplifier. The collector current of this transistor is defined by floating voltage  $V_1$  and resistor  $R_1$ . If on the + input of  $A_2$  amplifier the voltage  $V_2 = 0$ , the collector current  $I_{C1}$  is approximately equal to the input current of  $A_2$  amplifier,  $I_{C1} = I_1$ , since the base-emitter voltages of both transistors are equal (5). In this way it is achieved that the current pulse for integrating capacitor charging is defined by voltage  $V_1$  and resistor  $R_1$ . The equality of currents  $I_1$  and  $I_{C1}$  practically do not depend on the variation of temperature since

$\Delta v_{eb1}/\Delta T = \Delta v_{eb2}/\Delta T$ . This is used to achieve good temperature stability of switching elements. When the voltage  $V_1 = I_R R_1 = |v_{eb2}|$ ,  $v_2 = v_{eb1} = 0$  so that the collector current  $I_{c1} = 0$ .

The general purpose analog switch  $S_1$  is used as auxiliary switching element. When the switch  $S_1$  is off, current  $I_R$  passes from + voltage source through resistor  $R_1$ , producing on the resistor  $R_1$  voltage  $I_R R_1 = |v_{eb2}|$  so that  $v_2 = 0$  and  $I_{c1} = 0$ . When the switch  $S_1$  is on, the current  $I_R = 0$  and  $v_2 = v_{eb1}$ . In this case  $I_{c1} = I_1$ .

In this way, by using voltage pulses of constant duration from one shot multivibrator circuit, it is possible to produce current pulses of constant duration and amplitude.

### 3. EXPERIMENTS

The following components were used: Electrometer amplifier, type 302 K, having temperature drift  $150 \mu\text{V}/^\circ\text{C}$  and input leakage current less than  $10^{-14}\text{A}$ ; Integrating capacitor  $C_1 = 100 \text{ pF}$ , polystyrene; dual matched transistors  $T_1$  and  $T_2$ , type AD818, having  $\Delta v_{eb}/\Delta T = 5 \mu\text{V}/^\circ\text{C}$ ; Amplifier  $A_2$ , type AD523, having temperature drift  $15 \mu\text{V}/^\circ\text{C}$ ; Resistor  $R_1$ , stable wire wound resistor  $1 \text{ Mohm}$ ; Floating voltage  $V_1$  adjustable from  $0.7 \text{ V}$  to  $1.3 \text{ V}$ .

The current pulses amplitude was approximately  $1 \mu\text{A}$  and duration approximately  $10 \mu\text{sec}$ . The voltage pulses on integrating capacitor  $C_1$  approximately  $100 \text{ mV}$ . The adjustment of  $A_2$  amplifier output voltage on the precise value  $v_2 = 0$ , when switch  $S_1$  is off is achieved by potentiometer  $R_1$ . The adjustment of converter frequency is achieved by adjustment of floating voltage  $V_1$ . Sensitivity  $10^{-11}\text{A/Hz}$  is obtained. The measuring range achieved from  $10^{-12}\text{A}$  to  $10^{-7}\text{A}$  with the output frequency from  $0.1 \text{ Hz}$  to  $10,000 \text{ Hz}$ . The measured linearity of the current to frequency conversion at the temperature  $25^\circ\text{C}$  was better than  $2\%$ . The temperature circuit stability is examined by varying the temperature of switching elements,  $T_1$  and  $T_2$ . In the temperature range from  $0$  to  $50^\circ\text{C}$  the error was less than  $0.08\%/^\circ\text{C}$ .

### REFERENCES

- (1) J.Mc.QUAID, "Recycling Integrator for Measuring Nanoampere Currents", The Review of Scientific Instruments, Vol 36, No.5, May 1965, pp. 599-600.
- (2) F.GLASS, C.COUNTNEY, E.KENNEDY, H.WILSON, "A new approach to direct current integration", IEEE Transactions on Nuclear Science, Feb. 1967, pp. 143-147.
- (3) D.TAYLOR, "A Current-to-frequency converter for astronomical photometry", The Review of Scientific Instruments, Vol.40, No.4, April 1969, pp. 559-562.
- (4) E.SHAPIRO, "Linear seven-decade current/voltage-to-frequency converter", IEEE Trans. on Nuclear Science, Vol.17, Feb.1970, pp. 335-344.
- (5) M.ŠOBAJČIĆ, "A possibility of simultaneous logarithmic-linear direct current measurement", Nuclear Instruments and Methods, Vol 125, 1975, pp.401-412.

## A NEW DESIGN OF BETA EXTRAPOLATION ION CHAMBER

L. D. Brown,  
Department of Medical Physics - University of Aberdeen  
Foresterhill, Aberdeen.

## 1. INTRODUCTION

Although Haybittle (1) has shown that thin disc shaped ionization chambers can, under certain circumstances, be used successfully for beta ray dosimetry an extrapolation ion chamber of the type first developed by Failla (2) is generally regarded as the most satisfactory instrument for this type of measurement. Many such chambers with designs of varying sophistication have been described in the literature (3-7). Despite this the author knows of no relatively simple commercially available extrapolation chambers which can be used interchangeably with corresponding air equivalent wall photon chambers on dosimeters designed for general use in medical research centres or hospitals. This has led to a situation where such establishments frequently have calibration problems, for example with beta ray applicators used in radiotherapy or with personnel dosimeters used in situations where beta doses are likely to be encountered.

In U.K. hospitals a commonly available instrument is the electrometer type dosimeter (8) and air equivalent wall ionization chamber (9) originally developed for use during the study of patient doses associated with diagnostic radiological procedures which was carried out by a Committee under Lord Adrian from 1957 onwards (10). This paper reports the development of a beta extrapolation ion chamber designed specifically for use as a plug in alternative to the photon chamber in conjunction with the type 37 portable X-ray dosimeter referred to above.

The most widely used of the photon chambers supplied for this instrument has a volume of 35 cc. and with this the dosimeter has ranges giving full scale readings for dose rates between 30 rontgen/hour and 6 rontgen/hour, as well as integrating ranges corresponding to full scale readings between 0.3 rontgen and 100 rontgen.

## 2. THE PURPOSE OF THE NEW EXTRAPOLATION ION CHAMBER

Ideally the radiation dose rate at the surface of an extended beta ray source should be measured by determining the ionization in an accurately known but infinitely thin layer of air adjacent to the surface. An extrapolation chamber approximates to this ideal by enabling measurements to be made for a series of increasing thickness layers; from these a graph of current against electrode separation can be constructed and extrapolated back to zero thickness. Although the presence of the front electrode between the surface of the source and the sensitive volume of the ion chamber cannot be avoided, the effect of this too can be eliminated by taking readings for several front electrodes of different thickness and again extrapolating back to obtain the reading which would correspond to an infinitely thin electrode. Finally if a depth dose curve for the source is to be constructed thick front electrodes can be deliberately used to give the value of the dose rate below a corresponding thickness of absorber.

The extrapolation chamber described in this paper has two particular features:

(a) The inter-electrode separation or thickness of the air layer, is adjusted automatically to any one of five fixed values by turning the

central electrode to bring spring loaded locating pegs to the appropriate setting on a step wedge cut into the back plate of the chamber housing. This eliminates the need for the usual micrometer type adjustment of the electrode position and greatly simplifies the eventual determination of the actual dose rate in the chamber. It also ensures that the electrodes remain parallel when varying the separation.

(3) The area of the collecting electrode is  $3.5 \text{ cm}^2$  (corresponding to a radius of just over 1 cm.) This means that instead of the extrapolation graph being a plot of chamber current against electrode separation, it can be based on the dose or dose rate reading obtained from the type 37 X-ray dosimeter.

The graph of dose rate against separation is extrapolated back to zero and a dose rate reading for a separation of 0.3 mm is obtained from the extrapolated part of the curve. Since the sensitive volume of the chamber for this separation is 0.001 of that of the 35 cc. photon chamber the instrument calibration should then be correct if milliroentgen are read as roentgen.

By use of these two special features very rapid measurements of beta dose distributions can be made without recourse to the relatively lengthy setting up procedure and detailed calculations associated with the use of a conventional extrapolation chamber.

### 3. DESIGN OF THE NEW CHAMBER

The principle features are shown on Fig. 1. The main parts are constructed from I.C.I. "Perspex" plastic, and the front electrode is a sheet of I.C.I. "Mellinex" plastic coated with an evaporated layer of aluminium in a vacuum deposition plant. When it is used with the type 37 electrometer the collecting electrode is connected to the electrometer input whilst the surrounding guard ring is earthed. The polarising voltage is applied to the front electrode, but the -300 volts supplied by the electrometer is so high that if applied directly to the chamber its operation is brought into the proportional region.

FIGURE 1

EXPLODED DIAGRAM OF LEHMAN-LATYON ION CHAMBER

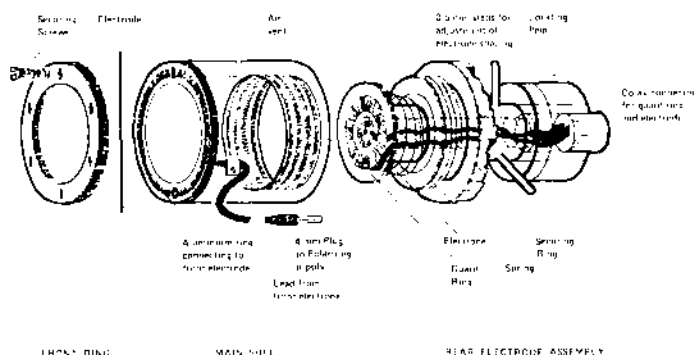

This polarising supply is therefore reduced by a potential divider attached to the baseplate of the chamber.

Sources of error in extrapolation chambers are commonly associated with the following faults:

(1) Lack of tension of the front electrode, leading to uncertain chamber geometry, and typically to the electrode being drawn into the chamber by electrostatic forces. (This is particularly troublesome if a series of different thickness electrodes are being used in order to extrapolate down to zero thickness).

(2) Lack of parallelism of the electrodes leading to a wedge shaped collecting cavity.

(3) The effect of finite width and depth of the groove between the collecting electrode and the guard ring

(4) Inadequate insulation resistance between these electrodes.

(5) Back scatter effects arising from the materials of which the chamber is constructed.

With the chamber under consideration the dimensions have been chosen to be large enough to ensure that its performance is not unduly affected by the width and depth of the groove between the electrodes, but not large enough for serious curvature to be inevitable with thin front electrodes. Furthermore the perspex used in its manufacture not only machines easily and accurately thus minimising other geometrical errors, but also has a very high resistivity, so that the resistance from the collecting electrode to earth exceeds  $10^7$  ohm. The main source of error is therefore probably associated with scattered beta radiation. Perspex has an effective atomic number of 6.24 and  $S$  rat. (Ratio of electron mass stopping power to that of air) of 1.066. Since the whole chamber has thick perspex walls and base the collecting volume approximates to a Bragg-Gray cavity in near tissue equivalent material and measured doses will correlate closely with those to be expected in soft tissue.

#### 4. EVALUATION OF THE CHAMBER PERFORMANCE.

Preliminary readings were obtained with the type 37 X-ray dosimeter replaced by a Keithley type 602 electrometer. This enabled the polarising voltage to be reversed and results to be obtained with both positive and negative ion currents. The measured current is of course the algebraic sum of the true ion current and the collected beta current - theoretically when using extrapolation chambers measured positive and negative currents should be averaged, but using the X-ray dosimeter only the negative ion current can be measured. Results showed that errors from this are small so long as care is taken to ensure that the source housing is at the same potential as the front electrode of the chamber, but any electrostatic field between the source and the chamber can have an appreciable effect on the observed dose distribution. Next extrapolation readings were obtained for various front electrode thicknesses down to 1 mg. per sq. cm. These plotted sufficiently regularly to confirm that when the front electrode was properly tightened it did not develop enough curvature to noticeably affect the chamber volume.



Finally in order to demonstrate the suitability of the chamber for practical measurements, a depth dose curve was constructed for a Radiochemical Centre  $^{90}\text{Sr} - ^{90}\text{Y}$  10 mCi extended area source in capsule type X112. The readings obtained are shown on Figure 2 and correlates well with results obtained from another extrapolation chamber of different design.

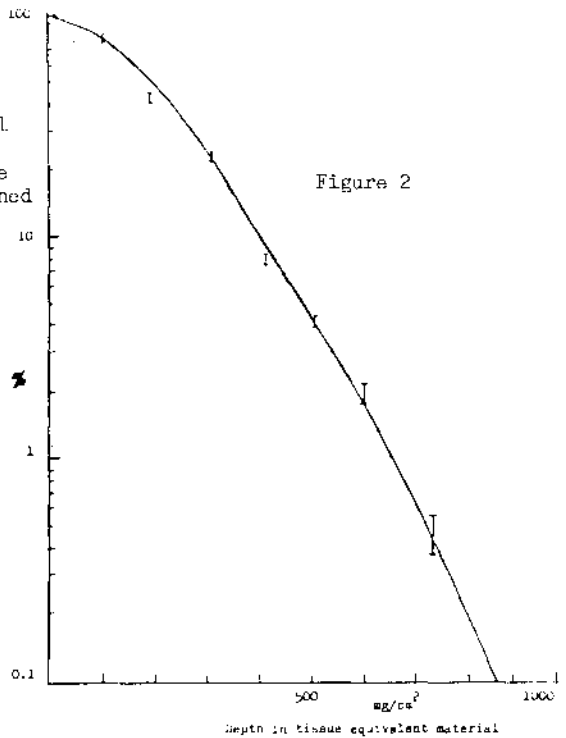

FIGURE 2  
CENTRAL AXIS  $\gamma$  DEPTH DOSE CURVE FOR RADIOCHEMICAL CENTRE  
10 mCi  $^{90}\text{Sr}$  EXTENDED AREA  $\pi$  SOURCE

#### REFERENCES

1. HAYBITTLE, J., Br. J. Radiology, 28, 320, 1955
2. FAJELA, C. Radiology, 29, 202, 1937
3. BORTNER, T.E., Nucleonics, 9, 3, 10, 1951
4. LOEVINGER, R., Rev. Sci. Instrum., 24, 907, 1953
5. SUPE, S.J., Int. J. Appl. Radiat. & Inst., 24, 515, 1973
6. FRANCIS, T.M., SEYMOUR, R. N.R.P.B. R-4 1972
7. PAYNE, W.H., WAGGENER, R.G. Medical Physics, 1, 165, 1974
8. STUART, S., OSBOEN, S.B., Phys. Med. Biol. 3, 255, 1959
9. OSBOEN, S.B., HURROWS, R.G., Phys. Med. Biol. 2, 37, 1958
10. Radiological Hazards to Patients, Intern (1959), Second (1960) and Final (1966) Reports of the Committee. H.M.S.O. London.

ABSORBED DOSE RATE METER FOR  $\beta$ -RAYS

K. Bingo

Division of Health Physics and Safety,  
Tokai Research Establishment, JAERI

## I. INTRODUCTION

To measure the absorbed dose rate, convenient instruments such as ionization chamber and GM survey meters for  $\gamma$ -rays do not exist for  $\beta$ -rays. A major reason is that the absorbed dose rate per fluence rate varies not only depending on the energy of  $\beta$ -rays but also the epidermal thickness of tissue (that is,  $\beta$ -rays are rapidly attenuated in media and transmission in a medium varies depending on the energy of  $\beta$ -rays).

In this paper, a method and an instrument for measuring directly the  $\beta$ -ray absorbed dose rate independent of  $\beta$ -ray energy and corresponding to the epidermal thickness of tissue in interest is investigated.

## II. MEASURING METHOD AND SELECTION OF SCINTILLATOR THICKNESS

The conversion factors for electrons from  $10^{-1}$  to  $2 \times 10^4$  MeV are given in ICRP Report 21, but those for  $\beta$ -rays are not given (1). Dose distributions in air and in water due to point and infinite plane sources of 37  $\beta$ -ray emitters were calculated and tabulated by W.G. Cross (2), on the basis of Spencer's calculation of electron transport equation (3). The relationship between absorbed dose rate per fluence rate and the maximum energy of  $\beta$ -ray, calculated from Cross's Tables, is shown in Fig. 1. The parameters, 7 and 40 mg/cm<sup>2</sup>, in Fig.1 are the epidermal thickness of body skin and finger tips, respectively. The value of fluence rate is defined on a surface of tissue.

The object of this paper is that the correlation between the counting rate per fluence rate of instrument and the maximum energy is made equal to the relationship between the absorbed dose rate per fluence rate and the maximum energy shown in Fig. 1, by selecting the scintillator thickness and counting the specified pulses.

Fig. 2 shows the pulse height distributions of various  $\beta$ -ray emitters measured by a rather thick plastic scintillator, e.g. 20 mm. If a relationship between the counting rate per fluence rate and  $\beta$ -ray maximum energy could be made equal to the relationship between the absorbed dose rate per fluence rate and  $\beta$ -ray maximum energy, a following proportional relation is satisfied,

$$\bar{D}_t(E_{max}) = K_t \bar{C}_t(E_{max}), \quad (1)$$

where,  $\bar{D}_t(E_{max})$  is the absorbed dose rate per fluence rate for  $\beta$ -rays whose maximum energy is  $E_{max}$  MeV. The suffix,  $t$ , represents the epidermal thickness of tissue in terms of mg/cm<sup>2</sup>.  $\bar{C}_t(E_{max})$  is the counting rate per fluence rate. The counting rate is obtained by counting pulses selected with a single channel analyzer according to the epidermal thickness of tissue.  $K_t$  is a proportional constant (conversion coefficient of counting rate to dose rate). Then, the absorbed dose rate can be obtained by multiplying the counting rate by the constant  $K_t$ .

In the case of the pulse height distributions measured by a thick scintillator such as shown in Fig. 2, the proportional relation of equation (1) could not be obtained extending wide range of energy. The reason is that the number of low height pulses, such as those between 10 and 20 channels, due to high energy  $\beta$ -rays are too small, for the purpose.

In order to increase a number of such pulses without varying other factors, the thickness of scintillator should be made less than the range of high energy  $\beta$ -rays. Pulse height distributions of  $^{90}\text{Y}$   $\beta$ -rays, measured by 1, 2, 3 and 5 mm thick plastic scintillators, are shown in Fig. 3. It is clearly shown that the pulse height distribution of high energy  $\beta$ -rays varies depending on the thickness of scintillator.

It was found that the suitable pulse height distribution for obtaining the proportional relation given in equation (1) was obtained with a 2 mm thick plastic scintillator.

### III. EXPERIMENTAL RESULTS

Attempts were made to obtain the proportional relations given in equation (1), using  $40\phi \times 2$  mm plastic scintillator as a detector and  $\beta$ -ray sources such as  $^{35}\text{S}$ ,  $^{45}\text{Ca}$ ,  $^{60}\text{Co}$ ,  $^{185}\text{W}$ ,  $^{137}\text{Cs}$ ,  $^{204}\text{Tl}$ ,  $^{198}\text{Au}$ ,  $^{24}\text{Na}$ ,  $^{32}\text{P}$ ,  $^{90}\text{Y}$  and  $^{42}\text{K}$  whose maximum energies are from 0.167 to 3.5 MeV. The thickness of detector's optical shield is  $1.7 \text{ mg/cm}^2$ .

Fig. 4 shows the pulse height distributions of  $^{35}\text{S}$ ,  $^{60}\text{Co}$ ,  $^{137}\text{Cs}$ ,  $^{204}\text{Tl}$  and  $^{90}\text{Y}$   $\beta$ -rays measured using the 2 mm thick plastic scintillator. The low peak at 106 channel of  $^{137}\text{Cs}$   $\beta$ -rays is due to conversion electrons of  $^{137}\text{Ba}$  and the peak lying from 60 to 70 channels of  $^{90}\text{Y}$   $\beta$ -rays is due to  $\beta$ -rays passed through the scintillator.

The dose sensitivity,  $S_{d,t}(E_{\text{max}})$  is defined as the ratio of counting rate to absorbed dose rate and is equal to a reciprocal of the conversion coefficient,  $K_t$ . The dose sensitivity for body skin ( $t$  is  $7 \text{ mg/cm}^2$ ) was almost constant and independent of  $\beta$ -ray energy, when the pulses between 2 and 80 channels shown in Fig. 4 were counted. The result is shown in Fig. 5. The dose sensitivity,  $S_{d,7}(E_{\text{max}})$ , is  $50 \text{ cps}/(\text{mrad/hr})$  and is constant within  $\pm 15\%$  for  $\beta$ -rays with maximum energy from 0.4 to 3.5 MeV, and the conversion coefficient,  $K_7$ , is  $2 \times 10^{-2} (\text{mrad/hr})/\text{cps}$  (i.e.  $100 \text{ cps}$  is corresponding to  $2 \text{ mrad/hr}$ ).

The dose sensitivity for fingers,  $S_{d,40}(E_{\text{max}})$ , could be made constant, by counting the pulses between 26 and 86 channels, and is also shown in Fig. 5.  $S_{d,40}(E_{\text{max}})$  is  $50 \text{ cps}/(\text{mrad/hr})$  and is constant within  $\pm 15\%$  for  $\beta$ -rays with maximum energy from 0.3 to 3.5 MeV. The conversion coefficient,  $K_{40}$ , is  $2 \times 10^{-2} (\text{mrad/hr})/\text{cps}$ , and is equal to  $K_7$ .

In order to measure the absorbed dose rate of  $\beta$ -rays in a mixed radiation field of  $\beta$ -rays and  $\gamma$ -rays, a 7 mm thick acrylic resin filter should be used at the front of the optical shield of the scintillator. Then, the difference between a level

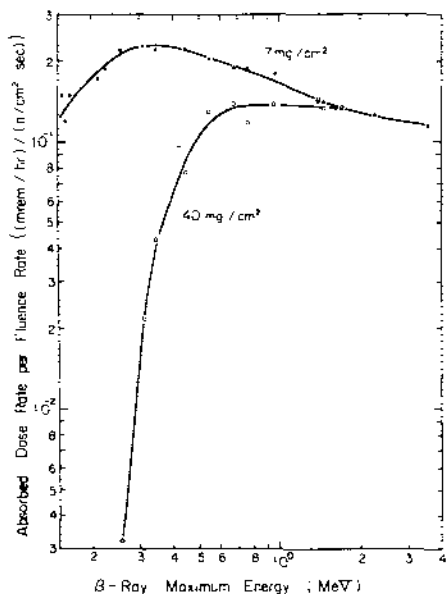

Fig. 1  $\beta$ -ray absorbed dose rate per fluence rate. Parameters in the figure are the epidermal thickness

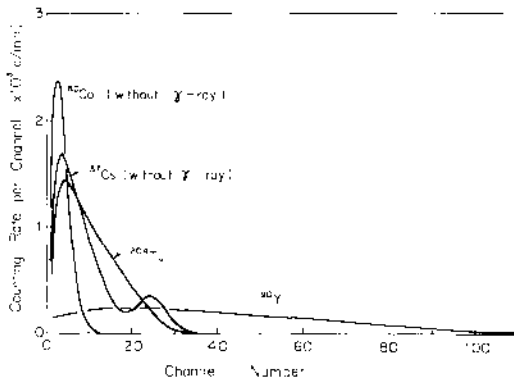

Fig. 2 Pulse height distributions of  $\beta$ -rays measured by the 20 mm thick plastic scintillator.

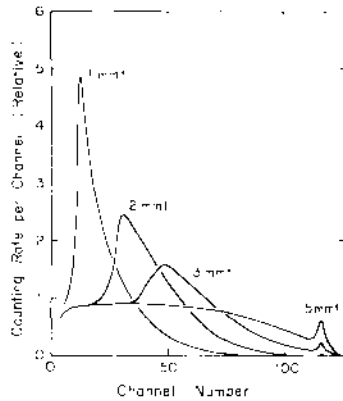

Fig. 3 Pulse height distributions of  $^{90}\text{Y}$   $\beta$ -rays measured by various thick plastic scintillators. Parameters are the thickness of scintillators.

indicated by the dose rate meter in the absence of the filter and a level indicated when the filter is used shows the absorbed dose rate of  $\beta$ -rays.

The detection limits of the absorbed dose rate for body skin and fingers are  $1.7 \times 10^{-2}$  mrad/hr and  $9.4 \times 10^{-3}$  mrad/hr, respectively.

#### IV. CONCLUSION

Absorbed dose rate of body skin and fingers can be measured directly by multiplying a counting rate by the conversion coefficient for  $\beta$ -rays with maximum energy 0.4~3.5 MeV and 0.3~3.5 MeV, respectively, using a single detector of the 2 mm thick plastic scintillator, and counting the pulses selected by a single channel analyzer whose lower level of discrimination and window width are set according to the epidermal thickness of the body skin and fingers, respectively.

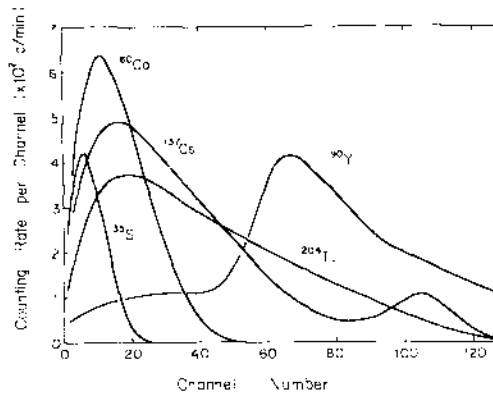

Fig. 4 Pulse height distributions of  $\beta$ -rays measured by the 2 mm thick plastic scintillator.

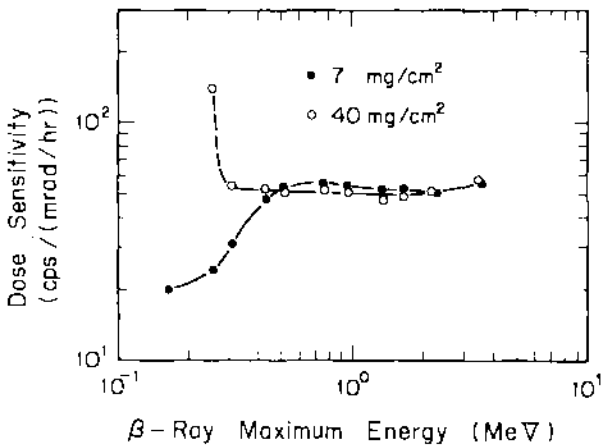

Fig. 5 Dose sensitivity of the instrument. Parameters are epidermal thickness.

#### ACKNOWLEDGEMENTS

The author would like to express his appreciation to Dr. T. Miyanaga and Dr. T. Numakunai for their encouragement and helpful discussions, and to Mr. T. Chida and Mr. K. Kawai for their assistance in the work.

#### REFERENCES

- (1) ICRP Report 21 (1973).
- (2) Cross, W.G., AECL - 2793 (1968).
- (3) Spencer, L.V., NBS Monograph 1 (1959), Phys. Rev. 98, 1957 (1955).

ETUDE ET MISE AU POINT D'UN REM-COMPTEUR A MODERATEUR ALLEGE

Y. HERBAUT, P. DORY, R. VIVIA

Centre d'Etudes Nucléaires de Grenoble  
Service de Protection et des Etudes d'Environnement  
65 X - 38041 GRENOBLE CEDEX1. BUT ET DEROULEMENT DE L'ETUDE

Nous voulons aboutir à la réalisation d'un rem-compteur à modérateur allégé. Ceci suppose :

- que la réponse du dispositif de détection, en fonction de l'énergie des neutrons, varie identiquement à la courbe d'équivalent de dose recommandée par la Commission Internationale de Protection Radiologique (1)

- que le poids et l'encombrement de la sonde soient le plus faible possible, afin de permettre la construction d'un appareil portatif beaucoup plus léger que ceux qui ont été conçus jusqu'alors.

Pour y parvenir, nous sommes partis des deux idées suivantes :

- détecter les neutrons épithermiques présents au centre d'un modérateur, plutôt que les neutrons thermiques habituellement mesurés dans les rem-compteurs classiques. Leur population, pour des neutrons incidents d'énergie donnée, doit en effet être maximale pour des épaisseurs de ralentisseur notablement inférieures à celles qui permettent d'obtenir, dans les mêmes conditions, le flux maximal de neutrons thermiques.

- Le détecteur idéal de neutrons épithermiques n'existant pas, on peut s'en approcher en utilisant un détecteur de neutrons thermiques placé sous cadmium. Si la section efficace de ce détecteur, pour la réaction considérée, est bien adaptée, seule une faible bande d'énergie sera prise en compte, correspondant à des neutrons en cours de ralentissement.

Cette étude a comporté trois parties :

- un calcul théorique préliminaire destiné à vérifier les hypothèses initiales.

- la réalisation d'un dispositif expérimental qui permette de confirmer ce calcul et de fixer l'épaisseur de modérateur la mieux adaptée. Pour ceci, nous avons choisi d'utiliser, comme partie sensible du détecteur, un cristal d'iodure de lithium. Cet élément est largement utilisé dans la technique multisphère.

- l'amélioration de la sensibilité du dispositif, en remplaçant le cristal par des compteurs proportionnels à  $^3\text{He}$ , par ailleurs plus stables et facilitant la discrimination n- $\gamma$ .

Les résultats auxquels ont conduit les deux premières parties ont été rapportés dans (2) et (3). Ils peuvent être résumés comme suit :

- le calcul théorique montre que la réponse d'un cristal d'iodure de lithium nu, placé au centre d'une sphère de 10 à 12 pouces de diamètre, suit correctement la courbe de dose de la C.I.P.R. Pour une réponse identique, l'épaisseur de modérateur est ramenée à environ 8 pouces si le cristal est recouvert de cadmium. Par contre, la sensibilité est divisée par un facteur 10.

- Les essais expérimentaux faits à l'aide d'un scintillateur Ili sous cadmium, ont confirmé qu'une sphère de 8 pouces est la mieux adaptée à nos besoins. Sa réponse suit convenablement la courbe de référence (voir figure 1). En revanche, sa sensibilité est faible : 0,20 c/s pour 1 nrem/h. Il est nécessaire de l'augmenter pour les besoins de la radio-protection (facteur 5 si possible).

- C'est ce que nous avons recherché au cours de la troisième partie de l'étude. Nous résumons ici les résultats de nos essais avec les compteurs à Hélium 3. Ils ont été rapportés en détail par ailleurs (4).

## 2. PRINCIPE DE FONCTIONNEMENT DU DETECTEUR

### a) Réaction Utilisée

La réaction mise en jeu lorsqu'un neutron interagit avec un noyau d'hélium est la suivante :

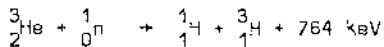

Proton et triton, n'étant pas dans un état excité, perdent leur énergie dans le volume sensible du compteur. Ils donnent ainsi naissance à des impulsions d'amplitude proportionnelle à l'énergie totale dissipée par la réaction. La section efficace de celle-ci varie comme suit : elle est d'environ 5 000 barns à 0,025 eV et obéit à une loi en  $1/v$  dans la gamme 0,001 - 0,1 eV. A 1 keV, elle n'est plus que de 20 barns, pour devenir faible (800 mbarns) au-delà de 300 keV.

### b) Couverture cadmium

Le compteur à hélium 3 n'est pas spécifiquement un détecteur de neutrons épithermiques, tel que souhaité pour réaliser le rem-compteur. On peut néanmoins lui faire remplir cet office en le plaçant sous une feuille de cadmium de 0,7 mm d'épaisseur. Ainsi, compte tenu des variations de section efficace de la réaction  ${}^3_2\text{He} (n, p) {}^3_1\text{H}$ , on peut considérer que la très grande majorité des neutrons détectés ont une énergie comprise entre 0,55 eV et quelques keV. Les impulsions résultantes sont donc distribuées autour d'une valeur moyenne peu différentes de (k. 764) mV avec une dispersion n'excédant théoriquement pas quelques pour cent.

Notons que les effets parasites (réaction de diffusion élastique, effets de parois et d'extrémités) qui sont habituellement gênants pour l'utilisation du compteur à hélium 3 en spectrométrie, sont négligeables pour son emploi en rem-compteur (4).

## 3. APPAREILLAGE UTILISE

Deux modèles de sondes ont particulièrement été étudiés, chacune d'un poids approximatif de 4 kg :

- l'une équipée d'un compteur de type 0,5 NH 1/1 KF (0,7 cm<sup>3</sup>), placé sous cadmium au centre d'une sphère de polythène de 8 pouces de diamètre,

- l'autre équipée d'un compteur de 5 NH 2,5 K placé au centre d'un modérateur identique.

L'ensemble de mesure est schématisé par le diagramme ci-dessous :

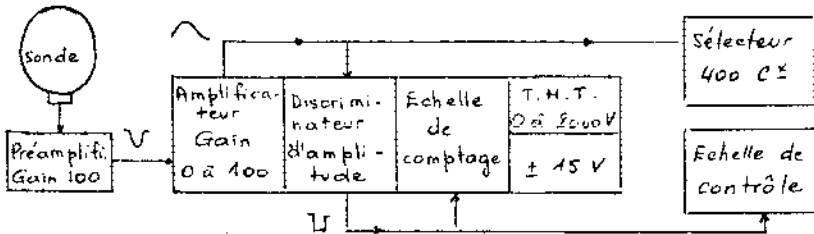

#### 4. REPONSE EN FONCTION DE L'ENERGIE DES NEUTRONS

a) sources de neutrons utilisés : le Van de Graeff de la Section d'Etudes et de Mesures de Neutrons Rapides de Cadarache nous a permis de couvrir la gamme d'énergie comprise entre 20 keV et 7 MeV, avec un pas tel qu'une vingtaine de points ont été explorés. Une mesure à 14,7 MeV a été faite à l'aide des neutrons générés par un accélérateur du C.E.N./GRENOBLE. Une source de Pu-Be, étalonnée par la LMRI, nous a permis une comparaison avec des neutrons monocinétiques de même énergie que l'énergie moyenne du spectre qu'elle délivre.

#### b) mode opératoire

La sonde à étudier est placée à une distance telle qu'elle permette d'assimiler la source de neutrons à une source ponctuelle, et que le flux de particules soit suffisant pour obtenir une statistique de mesure acceptable.

Pendant l'exposition N impulsions sont analysées par le rem-compteur. Toutes celles qui ont une amplitude supérieure au seuil de discrimination sont dénombrées par l'échelle de comptage.

Φ, la fluence neutronique au point d'exposition, est déduite de la mesure qui est simultanément faite par un moniteur. Celui-ci est placé dans une direction telle que les neutrons qu'il détecte aient la même énergie que ceux arrivant sur le compteur à étudier (symétrie dans le plan par rapport à la source de neutrons). Une correction d'angle solide permet de calculer la fluence au niveau du rem-compteur.

Les techniques utilisées pour la mesure de Φ (5) (6), permettent de connaître ce paramètre avec une erreur ne dépassant jamais 10 %, et dans la plupart des cas voisine de 4 %.

Toutes corrections faites (rayonnement diffusé, atténuation par l'air, contamination par des groupes de neutrons d'énergies parasites), l'efficacité du rem-compteur, ε, se calcule en reliant N à Φ.

#### c) résultats obtenus

Ils sont traduits par les courbes de la figure 1. L'erreur totale Δc/c, obtenue par une combinaison quadratique des erreurs partielles, n'excède jamais 5 %.



d) essais en centrale nucléaire : nous avons profité d'intercomparaisons de mesures de rayonnement, organisées par l'EDF autour du réacteur de la centrale de CHCOZ, pour tester notre rem-compteur dans un contexte opérationnel, à savoir :

- débits de dose allant de quelques mrem/h à plusieurs rem/h
- spectres complexes s'étendant de quelques eV à plusieurs MeV.
- composante  $\gamma$  importante.

Nous avons obtenu des résultats en bonne concordance avec ceux connus par d'autres techniques de détection (4).

### 5. CONCLUSIONS

La réponse du rem-compteur étudié, en fonction de l'énergie des neutrons, est satisfaisante. Entre 20 keV et 15 MeV, l'écart avec la courbe de dose CIPR, n'excède jamais un facteur 2, ce qui est convenable pour les besoins de la radioprotection. Entre 0,5 eV, limite inférieure résultant de la conception de l'appareil, et 20 keV, aucune mesure n'a été faite, faute de sources de neutrons. Néanmoins, les bons résultats obtenus lors des intercomparaisons en centrale nucléaire, laissent penser que la réponse du système doit être correcte aux basses énergies.

Il semble donc tout à fait possible de réaliser un rem-compteur portatif basé sur ce principe. Son poids ne devrait pas excéder 5 kg. Sa sensibilité doit pouvoir être encore améliorée par l'emploi de compteurs plus performants.

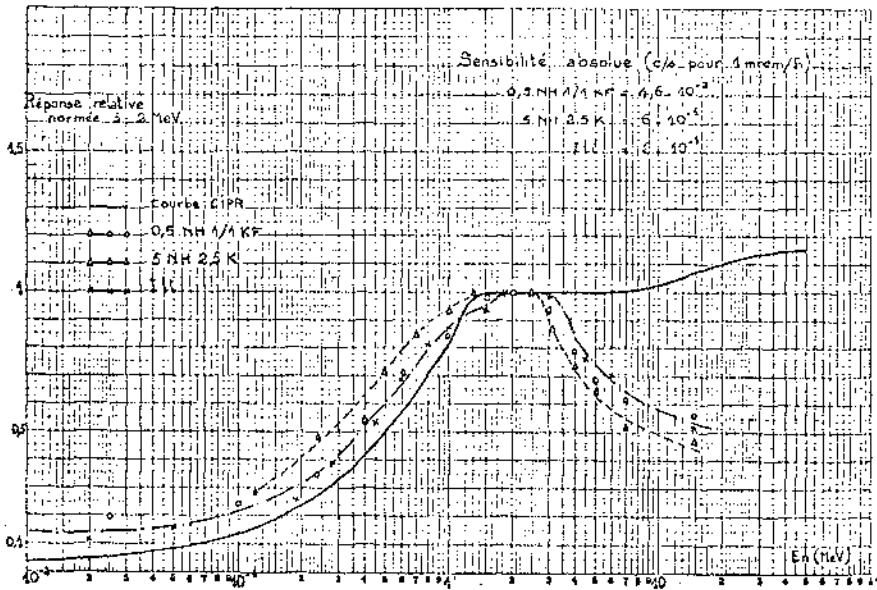

figure 1 - Sensibilité du rem-compteur en fonction de  $E(n)$ .

### BIBLIOGRAPHIE

- (1) CIPR 21 - Avril 1975
- (2) LYMBERIS C. - Rapport CEA R 4597 (1974)
- (3) BORY P. - HERBAUT Y. - Note SPEE/URMR 75.08 (1975)
- (4) BORY P. - HERBAUT Y. - VIVIA R. - Note SPEE/JRMR 76.17 (1976)
- (5) SZABO I. - SEMNR - à paraître
- (6) BORY P. - LOGRE P. - SPLHA/ACC 69-11 (1969)

## A NEUTRON DOSIMETRY SYSTEM FOR USE IN PROCESSING PLANTS

J A B GIBSON  
 Environmental & Medical Sciences Division  
 AERE, Harwell, Oxon, UK

## 1. INTRODUCTION

The monitoring of neutron dose equivalent has been a problem over the whole development period of nuclear energy. In the past, actual exposure to neutrons at a significant level has been restricted to areas where it has been possible to use indirect monitoring techniques. These include the use of the neutron to gamma-ray ratio or the measurement of a small part of the spectrum as is done with nuclear emulsions (1) or the neutron albedo technique (2) Nuclear fuel processing plants handling 'high burn-up' plutonium present problems due to fission neutrons from curium and plutonium isotopes and other neutrons from (a,n) reactions. The system discussed here is designed to work in controlled areas where the neutron dose equivalent rate exceeds 0.5 mrem h<sup>-1</sup>.

For convenience the system may be divided into five major parts,

- (i) personnel dosimeters for record purposes over periods up to 1 month,
- (ii) pocket alarm neutron dosimeters to provide a warning when an integrated dose equivalent limit is reached and give the integrated dose equivalent over periods up to 16 h,
- (iii) survey instruments to check slow changes in the original conditions,
- (iv) installed instruments to warn of sudden changes in the dose equivalent rate,
- (v) neutron spectrometry techniques to measure the initial conditions and to indicate the degree of complexity required for other parts of the system.

This paper will give a brief description of the dosimeters proposed under each of the main headings followed by preliminary results of tests in a full processing plant and conclusions as to the use of the system.

## 2. PERSONNEL DOSIMETERS FOR RECORD PURPOSES

It is expected that the neutron spectrum in a processing plant will be so variable that the use of albedo systems alone will not be possible. This was demonstrated in a processing plant (section 7) where the correction factor to the CLGB albedo dosimeter (2) varied from 6 to 35 over 9 locations and the nuclear emulsion dosimeters (1) may underestimate the dose equivalent by an order of magnitude.

The primary dosimeter (3) chosen for personnel monitoring is based upon the reaction,  $^{237}\text{Np} (n, \text{fission})$ . The fission fragments are detected with a track recorder of polycarbonate (makrofol type KG) of thickness 10  $\mu\text{m}$  and area  $\sim 100 \text{ mm}^2$ . The polycarbonate track recorder is removed from the dosimeter after exposure, etched in hot NaOH solution (7.1 N at 60°C) for 60 min, washed, dried, and counted in semi-automatic spark counter. The sensitivity range for 4 mg of neptunium is from 30 mrem to 10 rem with extension (by optical counting) up to 5 krem (500 rad) in the case of a nuclear accident. The dosimeter is worn on the front of a belt, the localised surface skin dose from the  $^{237}\text{Np}$  is about 11 mrem in 40 h and the background from spontaneous fission in the neptunium and impurities is equivalent to less than 50

mrem a<sup>-1</sup>. The neptunium dosimeter on the body gives an essentially dose equivalent response over the energy range of neutrons from thermal to 10 MeV (3) except for mono-energetic sources between 20 and 500 keV. However for all practical neutron spectra considered the total dose equivalent rate can be measured within overall limits of  $\pm 30\%$ .

Two CEGB albedo dosimeters (2) are included in the present system to give a comparison of the dose equivalent between the front and the back of the wearer and to give some indication of the orientation and of the neutron spectrum through the ratio of the albedo to neptunium dosimeters. Other more complex albedo dosimeters have been rejected because it has been shown that they do not provide additional unambiguous information (4). The CEGB dosimeter has been further simplified by using a two temperature read-out of a single chip of <sup>6</sup>LiF to give both gamma-ray and neutron data (5).

### 3. POCKET ALBINO NEUTRON DOSIMETER

The requirements for this dosimeter are an instrument to measure neutron dose equivalent at energies from thermal to 10 MeV with alarms at 20 and 100 mrem and a read-out facility at the end of a day. The proposed dosimeter (AERE type 0934) is based on an earlier prototype (6) with a reduction in weight, size and sensitivity to electronic noise. The detector is a low-pressure proportional counter with hydrogenous walls (for fast neutron detection > 10 keV) incorporating 3% of nitrogen to provide a dose equivalent response to thermal and intermediate energy neutrons through the <sup>14</sup>N(n,p) <sup>14</sup>C reaction. The EHT, amplifier, discriminator and scalars are based upon thick film circuits to reduce weight and power dissipation. The Ag-Zn batteries are rechargeable and can be used for up to 16 h on a single charge. The dosimeter weighs 590 g and is approximately 185 x 80 x 33 mm. The neutron sensitivity of the dosimeter is 10 counts per mrem and the accumulated counts are read out on a reader (AERE type 1245). The gamma-ray sensitivity is less than 5% of the neutron sensitivity in dose equivalent and the spurious count rate is less than 50 counts in 8 h.

### 4. SURVEY INSTRUMENTS

Regular surveys of a plant are necessary to locate slow changes in the dose equivalent rate due to changes in the fuel cycle. The Anderson-Braun principle (7) of thermalising neutrons in a large polythene moderator has been used with a <sup>3</sup>He thermal neutron detector developed by Leake (8) (AERE type 0075). The existing design is being improved to provide a liquid crystal display but with little reduction in weight below the present 7 kg. Recent calibrations have confirmed the response above 50 keV except that corrections are required for changed fluence-to-rem conversion factors (9) of up to 60%. A calibration at 25 keV with an Sb-Be source (10) found that the instrument over-reads by a factor of 4.5 at this neutron energy but this reduces to  $\sim 2.7$  at around 1 keV. A second instrument (Basson counter (11)) with a smaller sphere of diameter 63.5 mm has also been developed to detect beams and to provide qualitative neutron field measurement through the ratio of the Anderson-Braun to Basson instruments. This ratio can also be used to correct the CEGB albedo dosimeter.

### 5. INSTALLED INSTRUMENTS

Sudden changes in neutron dose equivalent rate can be divided into criticality excursions and other incidents (eg movement of fuel assembly outside prescribed limits). Criticality excursions can normally be detected by instruments measuring gamma-radiation but for the second class of incidents where the levels are not such as to require evacuation, neutron dosimeters

are required particularly where the n/γ ratio is large. Installed instruments similar to those discussed in section 4 can be used provided the necessary protection is provided (a) against false alarms and (b) against failure to alarm.

## 6. NEUTRON SPECTROMETRY IN THE PLANT

The degree of sophistication in the personal and other neutron instruments is dependent upon (a) the neutron spectrum and (b) its variability between working areas. The simplest form of spectrometry is based upon instruments with a restricted energy range eg  $^{10}\text{B}$  proportional counter with and without Cd for epithermal and thermal neutrons, a Basson counter (11) for intermediate energies a Dennis-Loosemore proportional counter (12) for neutrons  $> 100$  keV and the Anderson-Braun counter from thermal to 10 MeV. We have developed the more sophisticated system based upon moderating spheres (13) which provides a more detailed spectrum measurement for interpreting instruments. We have also used a  $^3\text{He}$  proportional counter (in Cd) for fast neutron spectrometry although its insensitivity at  $1 \text{ mrem h}^{-1}$  means that long counting times are required. The 6 moderating spheres require about 2 h to obtain sufficient data for analysis. It is essential to make measurements with at least two types of survey instrument at the same time as the spectrum is measured so that later routine checks can be used to give warning of changes in conditions.

## 7. PRELIMINARY RESULTS FROM TESTS IN A PROCESSING PLANT

All parts of the system were tested in a processing plant with the personnel and pocket dosimeters mounted on water-filled phantoms placed at 9 locations where the spectrum had been measured with the moderating spheres and survey instruments. Exposures of up to 1 month were made with regular checks with the survey instruments. A final repeat measurement of the neutron spectrum was made including the use of the  $^3\text{He}$  spectrometer at some locations.

The comparison of the dosimeters is given in table 1.

TABLE 1 Preliminary results for run 1

Location (a)	Measured dose equivalent rate in mrem h <sup>-1</sup>									n/γ Ratio (k)
	A-B Basson Ratio*			Neptunium		CEGB Albedo			F+B (j)	
	(b)	(c)	(d)	Front	Back	Front	Back	Corrected <sup>+</sup>		
1	0.35	0.047	7.4	0.37	-	0.035	0.014	0.26	0.026	1.4
2	0.98	0.114	8.6	1.02	-	0.083	0.037	0.72	0.121	1.3
3	1.05	0.030	35	0.71	-	0	0	0	0	0.2
4	0.33	0.026	12.7	0.37	0.37	0.013	0.019	0.17	0.032	0.8
5	42.5	2.23	19.1	36	3.2	1.93	0.57	37	2.50	7.0
6	0.45	0.076	5.9	0.20	0.18	0.030	0.045	0.18	0.075	1.7
7	0.55	0.063	8.7	0.50	-	0.052	0.026	0.45	0.078	3.3
8	0.45	0.063	7.1	0.39	0.20	0.027	0.063	0.19	0.090	1.4
9	0.70	0.090	7.8	0.84	-	0.070	0.031	0.54	0.101	3.5

$$* \text{Ratio} = \frac{\text{Anderson-Braun (A-B)}}{\text{Basson}} \quad + \text{CEGB front} \times \text{Ratio (g)} \times \text{(d)}$$

By comparing columns (b) and (e) it can be seen that the neptunium dosimeter is in reasonable agreement with the Anderson-Braun detector except for position 6, even though any neutron from the rear of the body will not be measured by the neptunium. The agreement between columns (b) and (i) is less

good than that for the neptunium dosimeter, indicating that even at one location the corrected result for the CEGB albedo dosimeter is not always a sufficiently precise measurement of the dose equivalent. However some of the CEGB dosimeter results on the front and back of the phantom (column (j)) show good agreement with the Basson Counter (column (c)). The final column (k) indicates the wide range in the ratio of neutron to gamma-ray dose equivalent from 0.2 to 7.0. Thus the preliminary conclusion is that the neptunium dosimeter is the only suitable device for making measurements in such a situation.

## 8. CONCLUSION

If plant operators are to be exposed to a significant dose of neutrons then it is necessary to provide personnel and alarm dosimeters giving a measurement of the dose equivalent in the spectrum observed. If the dose equivalent from neutrons is less than 20% of that from gamma-rays then control can be based upon the gamma-ray measurement. If the neutron spectrum in a plant is constant but the n/ $\gamma$  ratio varies then the CEGB albedo dosimeter with a correction factor is quite adequate for personnel dosimetry. However if the variation is as observed in section 7 then the neptunium dosimeter is required for the control of personnel exposures. It is important to emphasise that although the  $^{237}\text{Np}$  is contained in a sealed unit should be kept under strict administrative control to avoid any loss of the dosimeters from the plant. In choosing the appropriate dosimeters the use of neutron spectrometry and the various survey instruments is essential so that precise dose equivalent assessments can be made.

## REFERENCES

- (1) COOK J E, Fast neutron dosimetry using nuclear emulsions, AERE HP/R 2744 HMSO (1958)
- (2) HARVEY J R, HUDD T H R, TOMKINS S, Personnel dosimeter for measuring the dose from thermal and intermediate energy neutrons and from gamma and beta radiation in Neutron monitoring for Radiation Protection Purposes. STI/PUB/318, IAEA, Vienna p199 (1973).
- (3) HARRISON K G, A neutron dosimeter based upon  $^{237}\text{Np}$  fission, (to be published).
- (4) DOUGLAS J A, MARSHALL N, The response of some TL albedo neutron dosimeters. (to be published).
- (5) MARSHALL N, DOUGLAS J A, BUDD T, CHURCHILL W L, A two temperature read-out of thermoluminescent LiF, its properties and uses for personnel dosimetry. Int. Cong. ICRP, Paris, (1977).
- (6) DELARIEUX H J, SPANKE W G, YOSHIDA Y, LOUSMEIRE W R, DENNIS J A, A wide range personnel neutron dosimeter based on a proportional counter. Conf. on Nuclear Instrum, IEE No 47 p223 (1968).
- (7) ANDERSON I O, BRAUN J, A neutron rem counter. Nukleonik 6 p5, (1964).
- (8) LUCKE J B, An improved spherical dose equivalent neutron detector, Nucl. Instrum & Methods, 63 p329 (1968).
- (9) ICRP Publication 21 (Suppl. to Pub. 15), Data for protection against ionizing radiation from external sources, Pergamon Press, Oxford (1973).
- (10) HARRISON K G, HARVEY J R, BOOT S J, The calibration of neutron instruments and dosimeters at intermediate energies (to be published).
- (11) HASSON J K, A detector for intermediate energy neutrons. AERE-R3864 HMSO (1962).
- (12) DENNIS J A, LOUSMEIRE W R, A fast neutron counter for dosimetry in selected Topics in Radiation Dosimetry, STI/PUB/25, IAEA, Vienna p443 (1960).
- (13) BRANDELLT R L, EWING R I, BONNER T W, A new type of neutron spectrometer. Nucl. Instrum. & Methods 9 p1 (1960).

---

This work was supported in part by the Health and Safety Directorate of Euratom.

## AN ENERGY-INDEPENDENT ALBEDO-DOSIMETER FOR NEUTRONS

M. HEINZELMANN, G. OPLADEN, H. SCHÜREN

Kernforschungsanlage Jülich, Health Physics Division  
D 517 Jülich

## 1. INTRODUCTION

In personal dosimetry the dose equivalent of neutrons must be evaluated independently of the neutron energy. This is difficult. Most dosimeters are only useful for fast neutrons. Albedo dosimeters are sensitive also to thermal neutrons and those of intermediate energy, but their sensitivity decreases rapidly for neutrons of higher energy (1). Yoshida and Dennis were the first to propose an energy-independent personal neutron dosimeter (2). In their device neutrons of energies above 10 keV are detected by way of recoil protons, which are generated within the gas and the walls of the proportional counter. Neutrons with energies below 10 keV are moderated within the body of the bearer of the dosimeter and are reflected into the dosimeter. They are detected by means of the 580 keV protons, which are released by the  $^{14}\text{N} (n,p) ^{14}\text{C}$  reaction within the walls of the counting tube.

At Jülich also an energy independent neutron dosimeter has been developed. It is an albedo dosimeter like that of Yoshida and Dennis with the difference that a  $^3\text{He}$ -counter is used instead of a device using recoil protons.

A neutron dosimeter should be called sufficiently energy independent, when the measured value of the dosimeter for no energy deviates by more than the factor 2 from the intended sensitivity.

## 2. EXPLICATION OF THE METHOD

The working principle of the dosimeter is developed from that of the known Bonner detectors. These consist of a detector for thermal neutrons enclosed in a polyethylene sphere. For certain moderator diameters the reading of a Bonner counter is independent of energy for a large energy range. In figure 1 the sensitivity of a detector with a 5" moderating sphere (3) is compared with the dose equivalent ICRP response curve (4), both as functions of the energy. Both curves are reasonably parallel in the energy range from 1 eV to  $10^4$  eV. These curves should be parallel also for higher energies to get a truly energy independent dosimeter. Therefore either the sensitivity of the detector must be increased for higher neutron energies or be decreased for lower neutron energies. The latter is possible by using a  $^3\text{He}$ -counting tube, as we do. The height of the pulse generated within a  $^3\text{He}$  counter by a neutron is proportional to the sum of the kinetic energy of the neutron and the reaction energy of 770 keV, which is released by the  $^3\text{He} (np) ^3\text{H}$  reaction. A neutron of higher energy will generate a higher pulse

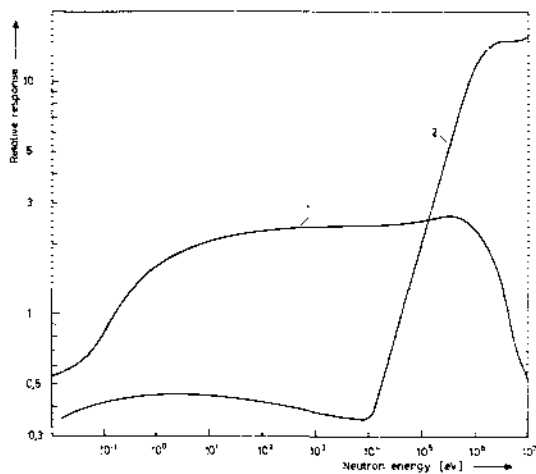

Fig. 1: Response of a 5-inch Bonner sphere (1) compared to the dose equivalent curve (2)

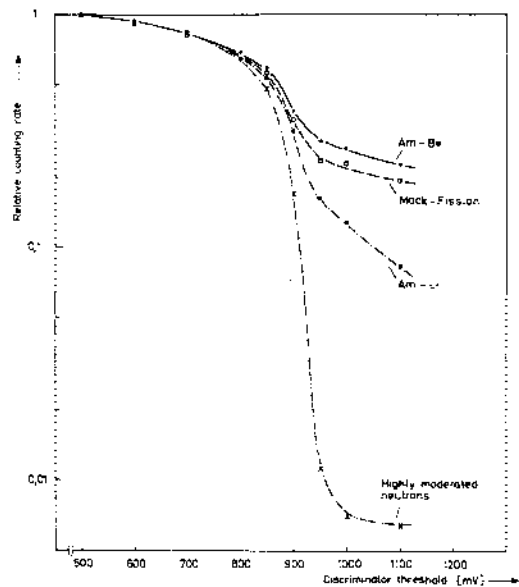

Fig. 2: Counting rate as a function of the discriminator threshold for neutrons of different sources

<sup>3</sup>He-counter inside cadmium and a moderator sphere of 2-inch wall thickness

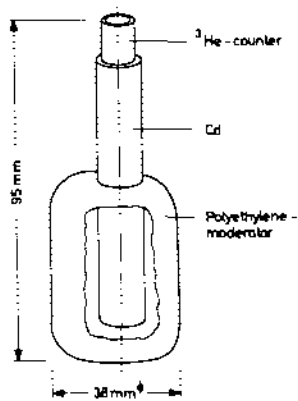

Fig. 3: Counter with moderator

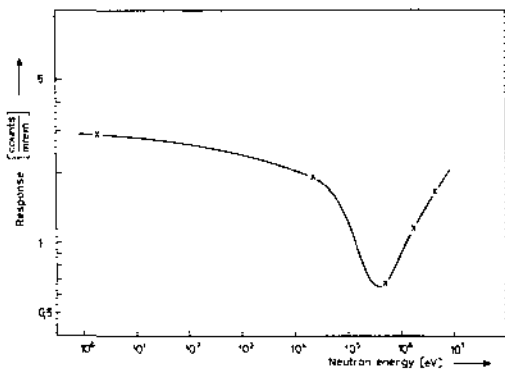

Fig. 4: Response of an albedo-dosimeter with <sup>3</sup>He-counter

than one of lower energy. When fast neutrons hit on the moderator, they will be partially slowed down. The  $^3\text{He}$  counter will generate pulses both from fast and moderated neutrons. The pulses of the  $^3\text{He}$ -tube pass through an amplifier and a discriminator to a counter. The number of counts decreases if the discriminator threshold is raised, and that so much faster, as the energy of the impingent neutron decreases (fig. 2). The sensitivity for neutrons of higher energy is substantially less decreased than for neutrons of lower energy. The measurements shown in fig. 2 were done with a Cadmium-coated  $^3\text{He}$ -Counter, this device was therefore not sensitive to thermal neutrons.

In a previous work we have shown that such a device with a small moderator with a wall thickness of 2" measures the dose rate equivalent of neutrons of 1.8 eV and for neutrons from 0.1 to 15 MeV independently from energy (5). The sensitivity was 0.5 cpm/mrem/h, which is too small for dose rate measurements.

### 3. THE ENERGY-INDEPENDENT PERSONAL DOSIMETER

The working principle as described above may be used for a personal dosimeter. As the body of the user of the dosimeter works like a moderator, the proper dosimeter moderator may be devised smaller. We have made experiments with a wall thickness of 0.5 in. of the moderator. The very small  $^3\text{He}$ -counting tube LMT 0.5 NH1/1K has a sensitive volume of a cylinder of 9 mm diameter and 10 mm height. The tube is clad in Cadmium. The measuring device is shown in fig. 3. It is only 95 mm long and has a diameter of 38 mm. This device was irradiated on a thoraxphantom with neutrons of different ( $\alpha, n$ )- or ( $\gamma, n$ )-sources. The sensitivity as a function of neutron energy is shown in fig. 4. At 1.8 eV a so called "negative source" proposed by Mijnheer (6) was used. Fig. 4 shows that the wanted energy independent response function is nearly achieved.

The sensitivity of the dosimeter is 1.4 pulses/mrem. The  $\gamma$ -sensitivity is very low, but increases with raising dose rate from neutrons. At a dose rate of 300 mrem/h from neutrons and 5 R/h from  $^{60}\text{Co}$ - $\gamma$ -rays the sensitivity for  $\gamma$ -rays was only 0.5 % of that for neutrons. The background was less than  $10^{-3}$  cpm.

The dosimeter needs a very stable and reliable electronics. An alteration of the discriminator threshold of 1 % changes the sensitivity for neutrons of an Am-Be source by 6.6 %. An alteration of the detector voltage of 1 % changes the sensitivity by 7.5 %.

The measurements as reported in fig. 4 were done with a conventional AEC-NIM electronics. A personal dosimeter should be small and of low weight, therefore the construction of a suitable electronics was begun. As a first step a high voltage supply, amplifier, discriminator and counter has been built within a box of 15 cm x 8 cm x 6 cm. Later on this electronics



must be reduced in size. This electronics deviced by us alters its detector voltage by less than 0.3 % by an external temperatur alteration of 10 °C. The amplification varies by 2 % at the same temperature alteration.

#### 4. CONCLUSION

Our measurements show the possibility of an energy independent neutron dosimeter, which is extremly insensitive to  $\gamma$ -radiation. There are to be done more measurements at other neutron energies and the electronics must be deviced smaller.

#### REFERENCES

- (1) ALSMILLER, R.G., Jr, BARISH, J., Health Phys. 26 (1974) 13
- (2) YOSHIDA, Y., DENNIS, J.A., Health Phys. 16 (1969) 727
- (3) AWSCHALOM, M., "Neutron Dosimetry", IAEA, Vienna (1967) p. 289
- (4) ICRP Publikation 21, Pergamon Press, Oxford (1973)
- (5) HEINZELMANN, M., SCHÜREN, H., FS-75-12-T (1976) p. 187
- (6) MIJNHEER, B.J., ATEN, A.H.W., Jr, "Neutron Monitoring for Radiation Protection Purposes", IAEA, Vienna (1973) Vol. II, p. 335

A METHOD FOR ESTIMATING NEUTRON FLUXES AND NEUTRON DOSES  
FROM THE ACTIVATION OF COMPACT BONE

P. Holmberg, Mervi Hyvönen and M. Tarvainen

Department of Medical Physics, University of Helsinki  
Helsinki, Finland

Today 14 MeV neutron generators are widely used for industrial and medical purposes. With the increasing use of these fast - neutron generators it is also of importance to develop a simple method for estimating neutron doses in case of accidental irradiation of personnel. In the present report we outline a method for estimating neutron doses by making use of the neutron induced activity in tissue, in particular compact bone. For the bone mineral hydroxyapatite  $\text{Ca}_{10}(\text{OH})_2(\text{PO}_4)_6$  contains calcium and phosphorus, the different isotopes of which are easily activated in a 14 MeV neutron flux [1-4].

Using the well-known formula for neutron activation analysis

$$N_{\text{obs}} = \frac{\sigma_A \Phi_{14} N_0 m_A \Theta \epsilon^f}{M_A \lambda} \gamma (1 - e^{-\lambda t_i})(e^{-\lambda t_o} - e^{-\lambda t_f}) \quad (1)$$

it is possible to deduce  $\Phi_{14}$ , the neutron flux at the energy 14 MeV, if the mass  $m_A$  of element A is known and  $N_{\text{obs}}$  is measured.

In the present work 14.7 MeV neutrons were produced in a neutron generator using the D,T -reaction. A rotating target assembly was used and the neutron production was approximately  $10^{10}$  n/s. Samples of compact bone were first irradiated in polystyrene containers, before being transferred to nonactivated containers. The gamma ray spectra which were then measured with a 110 cm<sup>3</sup> coaxial Ge(Li) - semiconductor detector, were stored in a PDP-9 computer. In this way it was possible to measure and store four consecutive 4096 channel spectra, ready for analysis by the VIPUNEN - program [5,6] on a Burroughs computer. For the energy and intensity calibration of the detector set-up IAEA standard sources were used in addition to the well-known sources of <sup>56</sup>Co and <sup>152</sup>Eu [1,7,8].

The present in vitro activation measurements were carried out using small samples of femur bones from cows. The masses of the bone samples were small, varying from 60 mg to 5 g. The irradiation times varied from 1 to 30 minutes, and the spectra

Fig. 1 Gamma ray spectra from activated compact bone and bone marrow (\* = background peak)

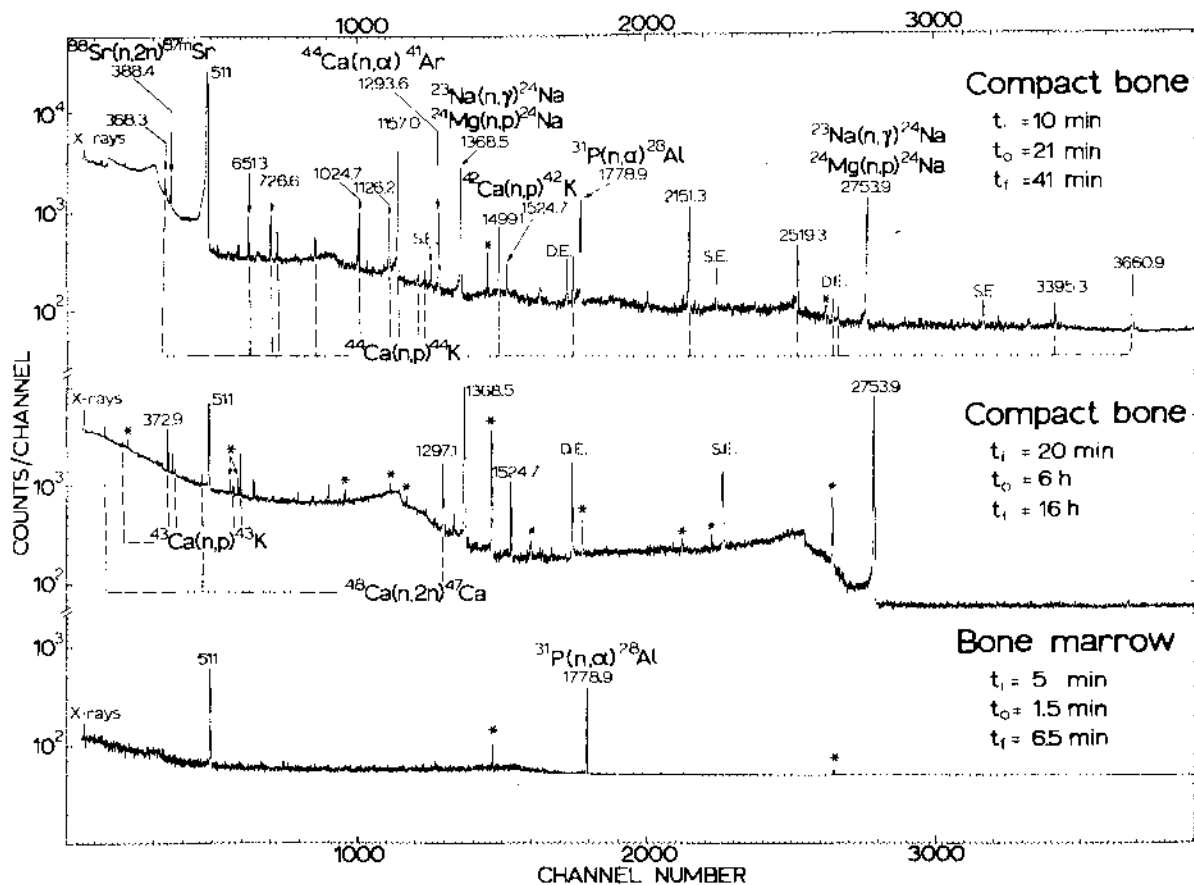

were recorded after waiting times ranging from 1 minute to 24 hours, depending on the half-life of the activity to be determined. Furthermore, the time taken to measure each spectrum varied from 5 minutes to 6 hours. In Fig. 1 we show a series of spectra recorded under different conditions. The spectra were analysed and on the basis of peak-energies and half-life determinations the gamma rays were assigned to their reactions. This is also indicated in the figure.

The upper part of Fig. 1 shows a spectrum recorded 21 minutes after exposure of compact bone to radiation. The irradiation time was 10 minutes and the measuring time was 20 minutes. In this spectrum several activities due to the neutron reactions on calcium are observed, the measuring conditions being favourable for the short-lived activities. Spectral peaks due mainly to the  $^{44}\text{Ca}(n,p)^{44}\text{K}$  reaction ( $T_{1/2} = 22$  min) are seen. Even the 1779 keV gamma ray from the  $^{31}\text{P}(n,\alpha)^{28}\text{Al}$  reaction ( $T_{1/2} = 2.24$  min) can still be detected. Furthermore, some longer lived activities are observed, although they come out more clearly in the next spectrum.

The middle part of Fig. 1 shows a spectrum recorded 6 hours after the irradiation of a sample of compact bone. The irradiation time was 20 minutes and the measuring time was 10 hours. In this spectrum the long-lived activities due to the  $^{42}\text{Ca}(n,p)^{42}\text{K}$  ( $T_{1/2} = 12.36$  h), the  $^{42}\text{Ca}(n,p)^{42}\text{K}$  ( $T_{1/2} = 22.2$  h) and the  $^{24}\text{Mg}(n,p)^{24}\text{Na}$  ( $T_{1/2} = 15.0$  h) reactions are clearly seen. Also the  $^{48}\text{Ca}(n,2n)^{47}\text{Ca}$  ( $T_{1/2} = 4.6$  d) reaction is observed at the energy  $E_{\gamma} = 1297$  keV.

By comparison, the lower part of Fig. 1 gives a spectrum recorded 1.5 minutes after the irradiation of a bone marrow sample. The irradiation time was 5 minutes, the waiting time 1.5 minutes and the measuring time was 5 minutes. The only activity clearly seen is that due to the  $^{31}\text{P}(n,\alpha)^{28}\text{Al}$  reaction ( $E_{\gamma} = 1779$  keV).

From these measurements we observe that the induced activities in compact bone can be recorded immediately after irradiation because of the presence of short-lived activities, mainly the  $^{31}\text{P}(n,\alpha)^{28}\text{Al}$  and  $^{44}\text{Ca}(n,p)^{44}\text{K}$  reactions. As the waiting time increases the  $^{42}\text{Ca}(n,p)^{42}\text{K}$  and  $^{43}\text{Ca}(n,p)^{43}\text{K}$  reactions are more suitable for activity measurements. For still longer waiting times the  $^{48}\text{Ca}(n,2n)^{47}\text{Ca}$  reaction can be used.

As can be seen from Fig. 1, there is a continuous change in the spectral shape arising from the different half-lives of the induced activities. As the isotopic composition of the hydroxyapatite is known, the changes provide a method for estimating both the irradiation time and the waiting time  $t_0$  by spectral analysis.

The neutron flux values  $\Phi_{1/4}$  can now be obtained from eq. (1) and it is possible to deduce the neutron spectrum  $\Phi(E)$  at different sites in tissue. The corresponding dose equivalent D.E. can then be calculated from the formula

$$\text{D.E.} = \int_0^{14 \text{ MeV}} \Phi(E) g(E) dE,$$

where  $g(E)$  is a conversion factor which takes the neutron energy loss mechanism into consideration. A method for the deduction of doses is outlined by Prouza, Heřmanská and Rakovič [9].

Compact bone has been chosen as reference material for neutron flux and dose estimates, because the several neutron reactions which occur cover a wide range of half-lives. Thus, depending on the irradiation procedure, different reactions can be used for the evaluation of  $\Phi_{1/4}$ .

#### References:

1. W.W. Bowmann and K.W. MacMurdo: Atomic Data and Nuclear Data Tables 13 (1974) 89.
2. G. Erdtmann and W. Soyka: "Die  $\gamma$ -Linien der Radionuklide", Kernforschungsanlage Jülich, Jul-1003-AC (1974).
3. S.A. Lis, Ph.K. Hopke and J.L. Fasching: J.Radioanal.Chem. 24 (1975) 125.
4. M. Bormann, H. Neuert and W. Scobel: in "Handbook on Nuclear Activation Cross-Sections", p. 87, IAEA, Vienna, (1974).
5. P. Paatero, E. Tuura and A. Siivola: Comment. Phys.-Math. 42 (1972) 283.
6. P. Paatero, E. Tuura and A. Siivola: Univ. of Helsinki, Rep. Ser. Physics No A17 (1973).
7. A. Kiuru, P. Holmberg and A. Siivola: Comment. Phys.-Math. 40 (1970) 113.
8. P. Holmberg: Dept. Physics, Univ. Oulu, Rep. No 34 (1973).
9. Z. Prouza, J. Heřmanská and M. Rakovič: Isotopenpraxis 10 (1974) 156.

RESPONSE OF A  $\text{BF}_3$  COUNTER WITH TWO PARAFFIN MODERATORS  
FOR NEUTRON DOSE EQUIVALENT RATES

Masao Oshino, Hiroshi Ryufuku, Yoshikazu Yoshida and Hatsumi Tatsuta

Division of Health Physics and Safety  
Japan Atomic Energy Research Institute

### 1. INTRODUCTION

For the measurement of dose equivalent rates of neutrons with energy range of epithermal to fast, a method using a  $\text{BF}_3$  proportional counter with two kinds of paraffin moderator (two-moderator method)(1) has been employed in the JAERI. Errors in the actual measurement by the two-moderator method are sum of the errors due to ambiguity of energy response of the detector and the errors in the theoretical derivation of the relation between the dose equivalent rate and count rates measured. In order to examine the accuracy of the method for slowed down neutrons, response of this method was compared with those of three types of rem counter.

### 2. TWO-MODERATOR METHOD

The two-moderator method utilizes two kinds of cylindrical paraffin moderator placed in turn over a  $\text{BF}_3$  counter.

Generally, the spectrum of neutrons having slowed down component is given as a linear combination of source spectrum and  $1/E$  spectrum. Dose equivalent rates due to a neutron spectrum represented as a linear combination of two components are given as a linear combination of the count rates with each moderator. Based on the fact described above, the dose response by the two-moderator method is determined as

$$\dot{H} \text{ (mrem/hr)} = K_1 N_1 + K_2 N_2 \quad (1)$$

where  $\dot{H}$  is dose equivalent rate and  $N_1$  and  $N_2$  the count rates in cpm of the counter with moderator 1 and moderator 2 respectively, and  $K_1$  and  $K_2$  are constants.

In the two-moderator method, a combination of two paraffin moderators of 8.5 cm and 4.5 cm in thickness was chosen so that the detectors have sufficient sensitivities for a wide energy range and have an appropriate difference between their energy responses. The paraffin moderators used in the experiment are shown in Fig. 1. The effective volume of the  $\text{BF}_3$  counter is 11.7 cm, and the pressure of  $\text{BF}_3$  gas ( $^{10}\text{B}$  enriched to 96 per cent) is 200 mmHg. Based on the energy responses of the counters with 8.5 cm and 4.5 cm thick paraffin moderators (1) respectively and the ICRP response curve(2),  $K_1$  and  $K_2$  were determined as  $13.5 \times 10^{-3}$  mrem/hr/cpm and  $-6.77 \times 10^{-3}$  mrem/hr/cpm, respectively, for the Am-Be source spectrum.

### 3. EXPERIMENTAL METHOD

Response obtained by this method and those of three types of rem counter to slowed down neutrons were measured using Am-Be neutron sources and concrete walls which were arranged as shown in Fig. 2. The rem counters used in the experiment were Andersson-Braun type, Bonner type and JAERI type (four  $\text{BF}_3$  counters are placed in a cylindrical paraffin moderator)(3) rem counters.

The spectrum of neutrons incident to the detector consists of two components (source spectrum and  $1/E$  spectrum) as described in Section 2, and the fraction of  $1/E$  component varies with position of neutron sources.

If one expresses the neutron spectrum  $\phi(E)$  by

$$\phi(E) \approx C_1 \phi_1(E) + C_2 \phi_2(E) \quad (2)$$

where  $\phi_1(E)$  is the Am - Be source spectrum and  $\phi_2(E)$  is the  $1/E$  spectrum, the total fluxes of which are normalized to be unity, and  $C_1$  and  $C_2$  are constants, then a fraction of  $1/E$  component ( $f$ ) is given by

$$f = \frac{C_2}{C_1 + C_2} \quad (3)$$

For various arrangements of the neutron sources, count rates of the detectors one by one were measured. In the two-moderator method dose equivalent rate was obtained using Eq. (1). The dose equivalent rates by the rem counters were obtained using the count rates measured and the conversion factors (mrem/hr/cpm) for the Am - Be source spectrum.

#### 4. RESULTS

Relative responses of the three types of rem counter to the present method are shown in Fig. 3. It is seen from Fig. 3 that all the responses of the three rem counters and of the detector of present method are consistent within  $\pm 40$  per cent in fractions of  $1/E$  component up to 0.7.

The dose equivalent rates obtained by present method agreed well with the measured dose equivalent rates of the Andersson-Braun type and Bonner type rem counters corrected for the dose equivalent rates based on the reported energy responses(4),(5) and the ICRP response curve (2).

From the results it was concluded that the two-moderator method has enough precision to measure the dose equivalent rates due to the slowed down neutrons.

#### REFERENCES

- 1) H. Ryufuku; Japan. J. appl. Phys., 5, 903,910.(1966)
- 2) ICRP Publication 21, Data for Protection against Ionizing Radiation from External Sources, Supplement to ICRP Publication 15, (1971)
- 3) H. Ryufuku; Application of the Multidetector Methods to Neutron Dosimetry, JAERI-M-5875 (in Japanese), (1974)
- 4) I. O. Andersson and J. Braun, Nucleonik, 6, 237, (1964)
- 5) D. E. Hankins; Los Alamos Report LAMS-2717, (1962)

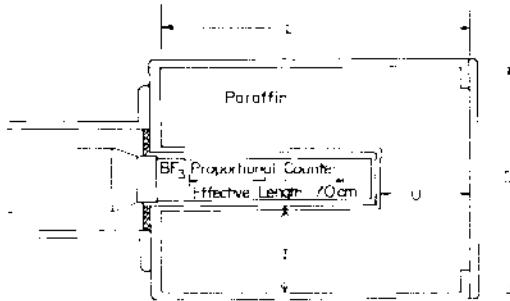

Dimensions (in mm)	Moderator No	
	1	2
D	190	110
L	220	180
C	85	45
U	85	45

The moderator is covered with a 1 mm thick cadmium case.

Fig. 1  $\text{BF}_3$  proportional counter with a cylindrical paraffin moderator.

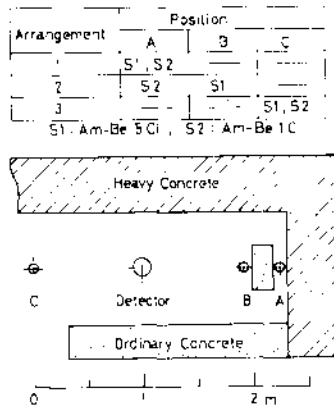
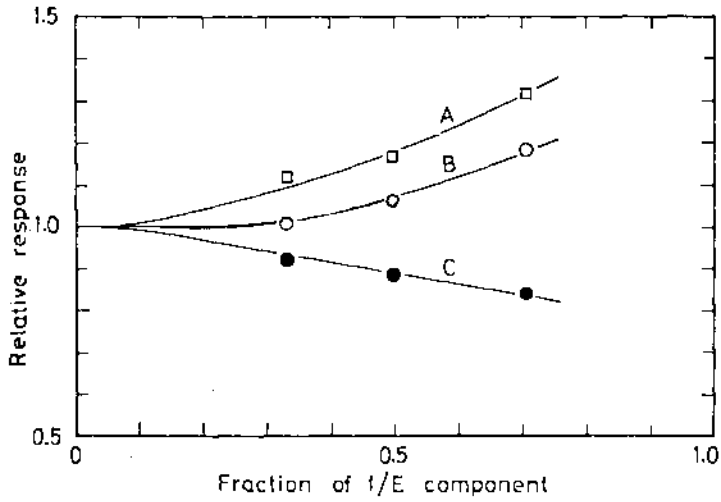

Fig. 2 Experimental arrangement of detector, neutron sources and concrete walls.





Curve A : Bonner type rem counter  
 Curve B : Andersson-Braun type rem counter  
 Curve C : JAERI type rem counter

Fig. 3 Relative responses of the rem counters to the two-moderator method.

**Fast Neutron Dosimetry in Nuclear Criticality Accidents**  
 Chong Chul Yook and Seung Gy RO\*  
 Dept. of Nuclear Engineering, Hanyang University  
 \*Korea Nuclear Fuel Development Institute  
 Seoul, Korea

1. Introduction

The objective of this study is to examine the dosimetric characteristics (or parameters) of some threshold detectors, and is then to suggest indium as a possible integral dosimeter for measuring the fast neutron dose in nuclear criticality accidents under the scattered-free condition. The interesting dosimetric parameters are the fission neutron spectrum-averaged cross-sections ( $\bar{\sigma}$ ) for the  $^{115}\text{In}(n,n')$ ,  $^{235}\text{U}(n,p)$  and  $^{27}\text{Al}(n,\alpha)$  reactions as well as the neutron fluence-to-dose conversion factors ( $\bar{d}$ ). These parameters have been numerically calculated by means of an electronic computer.

2. Calculation of Dosimetric Parameters

The  $\bar{\sigma}$  values were obtained by integrating the product of the differential cross-sections and the normalized fission neutron spectrum, that is, two representative formulae,<sup>1),2)</sup>

$$N_c(E) = \frac{0.655}{(0.667 \bar{E}_c - 0.493)^{1/2}} \exp\left\{ \frac{-(0.74 + E)}{0.667 \bar{E}_c - 0.493} \right\} \sinh\left( \frac{1.722 E^{1/2}}{0.667 \bar{E}_c - 0.493} \right) \dots(1)$$

and

$$N_m(E) = \frac{2.073}{\bar{E}_m} \left( \frac{E}{\bar{E}_m} \right)^{1/2} \exp(-1.5 E/\bar{E}_m) \dots\dots\dots(2)$$

in which subscripts c and m stand for the Watt-Cranberg<sup>3),4)</sup> and Maxwellian<sup>4)</sup> forms, respectively. E is the neutron energy in MeV and  $\bar{E}$  the average fission neutron energy. The differential cross-section data for the threshold reactions of interest were taken from a lot of articles.<sup>5)-9)</sup>

The  $\bar{\sigma}$  values were numerically calculated for the various values of  $\bar{E}$  in Eqs.(1) and(2) using an electronic computer CYBER-7J. Practically the calculation was performed in the interval from the thermal up to 20 MeV of neutron energy. The  $\bar{E}$  values were varied from that corresponding to thermal-induced fission[1.98 MeV in Eq.(1) and 1.935 MeV in Eq.(2)] up to that of 20 MeV neutron induced-fission[2.40 MeV in Eq.(1) and 2.335 MeV in Eq.(2)].<sup>10),11)</sup>

The  $\bar{d}$  value was numerically calculated by weighting the

the differential dose to  $N(E)$ . The differential dose in terms of Kerma and maximum dose was mainly extracted from reports.<sup>12),13)</sup> It should be noted that the autogamma dose from the  $^1\text{H}(n,\gamma)^2\text{D}$  reaction in the human body was exempted from the calculation of  $\bar{\sigma}$  based on the maximum dose, since it can be easily obtained by the conventional film dosimetry.

### 3. Results and Discussion

In Figs. 1-3 shown are the  $\bar{\sigma}$ -values as a function of the  $\bar{E}$ -values. The subscripts I, S, and A denoted in  $\bar{\sigma}$  refer to indium,

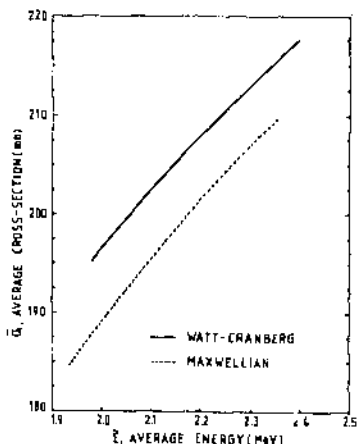

Fig. 1 AVERAGE CROSS-SECTION OF  $^{115}\text{In}(n,n')^{115\text{m}}\text{In}$  REACTION AS A FUNCTION OF AVERAGE FISSION NEUTRON ENERGIES.

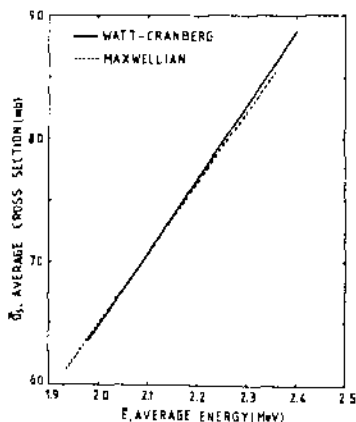

Fig. 2 AVERAGE CROSS-SECTIONS OF  $^{31}\text{Si}(n,p)^{31}\text{P}$  REACTION AS A FUNCTION OF AVERAGE FISSION NEUTRON ENERGIES.

sulphur and aluminum, respectively. The  $\bar{\sigma}$ -values increase with the  $\bar{E}$ -values. The Watt-Cranberg form gives the  $\bar{\sigma}$ -values higher than the Maxwellian form for indium while for aluminum the former gives the  $\bar{\sigma}$  values lower than the latter. The interesting result is that the  $\bar{\sigma}$  values for the  $^{32}\text{S}(n,p)$  reaction are nearly independent of the spectral functions, i.e., Eqs.(1) and (2). This tendency is also demonstrated in Table 1.

In Table 2 summarized are the  $\bar{\sigma}$  for the neutron spectrum from  $^{235}\text{U}$ -fission induced by thermal and 20 MeV neutrons. In the last row included is the  $\bar{\sigma}$  ratio of the thermal-to-20 MeV neutron fissions. For the  $^{115}\text{In}(n,n')$  reaction, the ratio is relatively small compared to the other reactions. In fact, this ratio may

be further decreased in actual circumstances of criticality accidents. Bondarenko et al.<sup>14)</sup> report that  $\bar{E}$  value of fission neutrons induced by fission neutron itself was observed to be

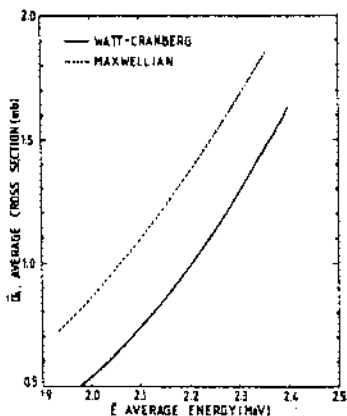

Fig.3 AVERAGE CROSS-SECTION OF  $^{235}\text{U}(n, f)^{235}\text{U}$  REACTION AS A FUNCTION OF AVERAGE FISSION NEUTRON ENERGIES.

2.03 MeV, leading to 1.067 of the cross-section ratio for both Eqs.(1) and (2). This may hint that indium can yield neutron fluence values being effectively independent of virgin neutron spectrum in criticality accidents where the fission neutrons are completely free from contamination of the scattered-neutrons.

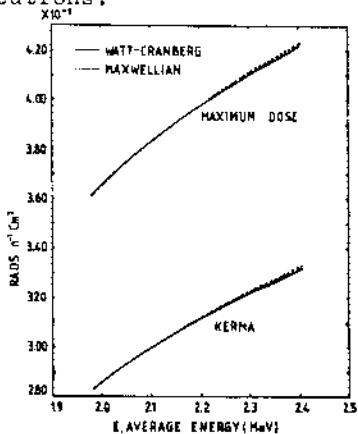

Fig.4. NEUTRON FLUENCE-TO-DOSE CONVERSION FACTOR AS A FUNCTION OF AVERAGE FISSION NEUTRON ENERGIES.

Table 1. Comparison of Average Cross-Section Ratio Obtained by Different Spectral Functions of Fission Neutrons

Fission type	AVERAGE CROSS-SECTION RATIO		
	$\bar{\sigma}_{24} / \bar{\sigma}_{23}$	$\bar{\sigma}_{24} / \bar{\sigma}_{23}$	$\bar{\sigma}_{24} / \bar{\sigma}_{23}$
Thermal Fission	1.097	1.037	0.994
20 MeV Neutron Fission	1.058	1.041	0.987
$\bar{\sigma}_y / \bar{\sigma}_n$ (for 20 MeV)	0.982	1.004	1.070
$\bar{\sigma}_y / \bar{\sigma}_n$ (for thermal)			

Table 2. Average Cross-Sections of the Threshold Sections for Neutron Spectra from  $^{235}\text{U}$  (thermal) and  $\alpha$ (20 MeV) Fissions

Fission type	Average Cross-Section (mb)					
	Watt-Cranberg Form			Maxwellian Form		
	$^{115}\text{U}(n, p)$	$^{32}\text{S}(n, \gamma)$	$^{27}\text{Al}(n, n')$	$^{115}\text{U}(n, p)$	$^{32}\text{S}(n, \gamma)$	$^{27}\text{Al}(n, n')$
Thermal Fission	195.14	45.47	0.52	196.52	61.19	0.76
20 MeV Neutron Fission	215.83	86.75	1.63	209.69	89.27	1.05
$\bar{\sigma}_y$ (for 20 MeV)						
$\bar{\sigma}_y$ (for thermal)	1.12	1.40	3.21	1.14	1.39	2.97

Table 3. Computed Zero and Maximum Dose Conversion Factor per Unit Fluence for Neutron Spectra from  $^{235}\text{U}$  (thermal) and  $\alpha$ (20 MeV) Fissions

Fission type	Conversion Factor			
	Watt-Cranberg		Maxwellian	
	Zero (rad/m <sup>2</sup> /cm <sup>2</sup> )	Max. dose (rad/m <sup>2</sup> /cm <sup>2</sup> )	Zero (rad/m <sup>2</sup> /cm <sup>2</sup> )	Max. dose (rad/m <sup>2</sup> /cm <sup>2</sup> )
$\alpha$ (thermal) fission	$2.89 \times 10^{-9}$	$5.61 \times 10^{-9}$	$2.75 \times 10^{-9}$	$5.52 \times 10^{-9}$
$\alpha$ (20 MeV) fission	$3.51 \times 10^{-9}$	$6.77 \times 10^{-9}$	$3.27 \times 10^{-9}$	$6.46 \times 10^{-9}$
$\bar{K}$ (for 20 MeV)				
$\bar{K}$ (for thermal)	1.17	1.17	1.19	1.19

Shown in Fig. 4 are the  $\bar{d}$  value as a function of the  $\bar{E}$  values. The  $\bar{d}$  value is insensitive to spectral functions together with the fissioning types. This is also listed in Table 4. This fact makes indium applicable as an integral fast neutron dosimeter in criticality accidents.

#### 4. References

- 1) J. Terrell, Phys. Rev. 113(2), 527(1959).
- 2) S.G. Ro and J.S. Jun, J. Korean Nucl. Soc. 7(2), 119(1975).
- 3) B.E. Watt, Phys. Rev. 87(6), 1037(1952).
- 4) L. Cranberg, G. Frye, N. Nereson, and L. Rosen, Phys. Rev. 102(3), 662(1956).
- 5) H.C. Martin, B.C. Diven, and R.F. Taschek, Phys. Rev. 92, 199(1954).
- 6) J.P. Butler and D.C. Santry, Canadian J. Phys. 41, 372(1963).
- 7) H. Liskien and A. Paulsen, EUR 119e(1963).
- 8) H.O. Menlove, K.L. Coop, and H.A. Grench, Phys. Rev. 163, 1308(1967).
- 9) R.F. Rago and N. Goldstein, Health Phys. 14, 595(1968).
- 10) W.G. Davey, Nucl. Sci. Eng. 44, 345(1971).
- 11) J. Terrell, Phys. Rev. 127(3), 880(1962).
- 12) ICRU Report-13(1969).
- 13) USNBS Handbook-63(1957).
- 14) I.I. Bondarenko, B.D. Huzminov, L.S. Kutsayeva, L.I. Prokhorova, and G.N. Smirenkin, Proc. 2nd. U.N. Int. Conf. Peaceful Uses of Atomic Energy 1, p. 353, Geneva(1958).

## ANALYSE QUALITATIVE ET QUANTITATIVE DU PLUTONIUM DANS LES FÛTS DE DECHETS SOLIDES

J. ANNO et E. ESCARIEUX  
Commissariat à l'Energie Atomique  
Centre d'Etudes de Bruyères-le-Châtel (FRANCE)

### I - INTRODUCTION

Pour gérer les déchets radioactifs au Centre d'Etudes de Bruyères-le-Châtel nous utilisons une méthode d'analyse qualitative et quantitative du plutonium dans les fûts de déchets solides par spectrométrie gamma. Après avoir décrit le procédé et l'instrumentation utilisés, nous présentons les expériences réalisées et les résultats acquis. Nous précisons les performances atteintes et nous les comparons à celles obtenues par la mesure des neutrons de fission spontanée du  $^{240}\text{Pu}$ .

### 2 - METHODE (1) (2) (3)

L'utilisation d'un système mécanique, permettant de placer le fût dans la position voulue par rapport au détecteur, et d'une collimation appropriée de ce dernier, permet l'analyse d'un fût en plusieurs parties. Un bon compromis entre le temps de comptage et la précision obtenue conduit à procéder par "comptage en deux positions". Outre l'identification des radioéléments, la spectrométrie gamma permet l'identification isotopique du plutonium.

L'évaluation quantitative du plutonium est faite en deux temps :

- . Le poids de plutonium correspondant au taux de comptage mesuré est lu sur une courbe d'étalonnage.
- . Le poids de plutonium présent dans le fût se déduit de ce relevé en lui appliquant une correction tenant compte de la matrice du fût et du nombre de positions utilisées pour l'analyse.

Un abaque indique l'erreur statistique en fonction de la masse de Pu et du temps de comptage.

### 3 - DISPOSITIF EXPERIMENTAL

**Système mécanique :** Le plateau permet d'amener le fût dans la position de comptage voulue; il tourne à la vitesse de 7,5 tours par minute. Le mouvement d'élévation et de descente lui est communiqué par un vérin actionné par une centrale hydraulique.

**Chafne de spectrométrie :** Le détecteur est un GeLi de 90 cm<sup>3</sup>, 20 % d'efficacité relative et 2,3 keV de résolution sur le pic de 1,33 MeV du Cobalt 60. La chafne électronique comprend le préamplificateur, un amplificateur ORTEC modèle 472 et un codeur Intertechnique CT 103. L'analyse et le traitement du signal sont faits par un PLURIMAT 20 Intertechnique et télétype. Nous utilisons en périphériques un lecteur rapide I.E.R., un perforateur rapide FACIT et un traceur de courbe RA 102.

### 4 - ETUDE EXPERIMENTALE

#### 4.1 - Détermination de la composition isotopique (4)

Le  $^{240}\text{Pu}$  a des raies à 104 et à 160 keV généralement en interférence avec les raies des autres isotopes; sa quantité est fonction de la composition isotopique. Considérons dans un spectre deux raies d'énergies proches; elles subissent pratiquement les mêmes absorption et autoabsorption. Le rapport de leurs intensités s'écrit :

$$\frac{I_{E_i}}{I_{E_j}} = K_{ij} \cdot \frac{f_i}{f_j}$$

$f_i$  : teneur du Pu en isotope  $i$   
 $f_j$  : teneur du Pu en isotope  $j$   
 $K_{ij}$  : constante connue pour une installation

A une composition isotopique donnée du plutonium d'origine déterminée, ne correspond qu'une valeur du rapport  $\frac{I_{E_i}}{I_{E_j}}$  ; la figure 1 montre la variation expérimentale de ce rapport en fonction de la teneur en  $^{240}\text{Pu}$ .

#### 4.3 - Mesure du plutonium selon un comptage en deux positions :

Au taux de comptage mesuré  $\mathcal{C}$  de la raie à 375 keV correspond un poids de Pu apparent,  $P_0$ , lu sur la courbe d'étalonnage, figure 2. L'étalonnage a été réalisé en plaçant les sources à l'intersection de la normale au détecteur ( $z = 0$ ) et de l'axe du fût en rotation ( $r = 0$ ). Il faut donc tenir compte du fait que les déchets occupent des positions quelconques dans le fût. La figure 3 montre la variation du rapport  $\mathcal{C}(r, z)/\mathcal{C}(r = 0, z = 0)$  à  $r = 0$ ,  $r = 15$  cm et  $r = 27$  cm. Successivement en faisant la somme correspondante aux deux positions et pour nos conditions de mesure, la valeur moyenne obtenue vaut  $R_p = 0,85$ . Nous devons également tenir compte de l'absorption  $T$  de la raie à 375 keV dans la matrice de remplissage du fût. Pour cela nous faisons l'hypothèse que nous sommes en présence d'une matrice vinylique homogène. Une étude de nos déchets et une vérification expérimentale du type de la figure 4, ont montré que notre hypothèse était vérifiée pour 65 % de nos fûts de déchets. Finalement le poids de Plutonium présent dans le fût s'exprime par :

$$P = P_0 \cdot \frac{1}{R_p} \cdot \frac{1}{T}$$

#### 5 - PRECISION - PERFORMANCES

La masse de plutonium  $^{239}$  dans un fût dont le contenu est assimilé à du vinyle, peut être exprimée par la relation approchée suivante :

avec  $\mathcal{C}$  : taux de comptage de la raie à 375 keV

$$m = \left( \frac{\mathcal{C}}{k} \right) \cdot \frac{1}{R_p \cdot T}$$

$k, x$  : Coefficient de la courbe d'étalonnage assimilée  
 $R_p$  : Rendement global moyen  
 $T$  : Transmission de la raie à 375 keV

Pour une matrice vinylique homogène, les erreurs commises sont :

Erreur systématique : elle est de l'ordre de 18 % qui se répartissent ainsi :

. Incertitude sur la courbe d'étalonnage : + 10 %  
 . Incertitude sur la transmission  $T$  :  $\frac{\Delta T}{T} = 2\%$   
 . Incertitude sur le rendement global moyen  $R_p$  :  $\frac{\Delta R_p}{R_p} = 6\%$

Erreur statistique :

De l'expression de  $m$ , on tire :  $e = \frac{\Delta m}{m} \gg \sqrt{\frac{1}{k} + \frac{1}{tm}}$

Cette relation nous donne l'incertitude statistique probable  $e$  en fonction de la masse de Pu à mesurer pour un temps déterminé, figure 5. On en déduit le temps de comptage pour une erreur statistique fixée, en fonction de la masse limite à déterminer.

Par exemple on peut détecter 32 mg de Pu dans un fût de 200 l. avec une erreur totale de 30 % (18 % d'erreur systématique et 12 % d'erreur statistique) en 15 mn de comptage ou 3,2 g avec une erreur de 20 % (18 % d'erreur systématique et 2 % d'erreur statistique) en 5 mn de comptage.

## 6 - COMMENTAIRES SUR L'ANALYSE PAR SPECTROMETRIE GAMMA

La méthode d'analyse par spectrométrie gamma est insuffisante pour les fûts à matrice lourde ou inhomogène (35 % de nos fûts de déchets) du fait de l'erreur commise sur la valeur de la transmission.

On peut alors avoir recours à la méthode d'analyse par mesure des neutrons de fission spontanée (5) et (6). Selon (6) et dans les conditions d'installation décrite, une telle mesure permet de détecter 10 mg de plutonium 240, dans un fût de 100 l, en 1 min de comptage avec une erreur de 20 à 30 %. Cette mesure neutron est donc rapide mais la spectrométrie gamma demeure indispensable pour l'identification de la teneur isotopique toujours nécessaire.

La figure 6 illustre une comparaison expérimentale, effectuée sur un lot de 10 fûts de 100 l, entre les deux méthodes. Elles donnent des résultats généralement concordants pour les contenus en plutonium faibles et moyens. Des écarts notables existent pour les contenus élevés, de 20 à 50 g de Pu. L'écart extrême est obtenu sur un fût à matrice lourde.

Les deux méthodes s'avèrent remarquablement complémentaires :  
- La méthode neutron bien adaptée pour matrice lourde et mesure du  $^{240}\text{Pu}$   
- La méthode gamma bien adaptée pour matrice légère et mesure du  $^{239}\text{Pu}$   
Les erreurs sont du même ordre de grandeur. Plutôt que concurrents les deux méthodes sont nécessaires pour traiter l'ensemble des fûts de déchets d'un centre nucléaire.

## 7 - CONCLUSION

La limite de détection de notre installation de contrôle des déchets par spectrométrie gamma est de 25 mg de plutonium 239 dans un fût de 200 l, avec une probabilité correspondant à 3 $\sigma$ .

On a intérêt à disposer d'un détecteur de gros volume afin de diminuer le temps de comptage; ce dernier n'est pas trop prohibitif lorsqu'il est voisin de 10 min compte tenu de ce qu'il faut par ailleurs de l'ordre de 45 mn pour traiter un fût depuis sa position de pré-stockage jusqu'à son évacuation. Dans ces conditions et pour un amortissement du matériel calculé sur 5 ans, le traitement d'un fût, analyse comprise, coûte environ 250 francs.

La méthode d'analyse des déchets par spectrométrie gamma est bien adaptée à la mesure du plutonium pour des fûts à matrice légère et homogène. Elle est insuffisante et hasardeuse pour les fûts à matrice lourde ou inhomogène; elle demeure indispensable à la détermination isotopique nécessaire pour une analyse par mesure neutron à laquelle il faut alors faire appel.

## REFERENCES

- (1) BIRKHOFF G et Al. EUR/S/IS/123/76 - Jauv. 76. Guide to monitoring of plutonium contaminated solid waste streams.
- (2) CLINE S. E. - ANGR 1055 - A relatively simple and precise technique for the assay of plutonium waste (72)
- (3) AUGUSTON RH et REILLEY TD - LA 5651 M - Fundamentals of passive non destructive assay of fissionable material (1974)
- (4) GOUGUET - Rapports CEA R 4399 - R 4666
- (5) BERG R. et Al - EURATOM Report - EUR 5158e ISPRA 1974
- (6) ARNAL T et Al. - Détermination de la teneur en plutonium dans les fûts de déchets solides - Séminaire sur la gestion des déchets solides contaminés par du Pu - Marcoule (14-16 Octobre 1974)



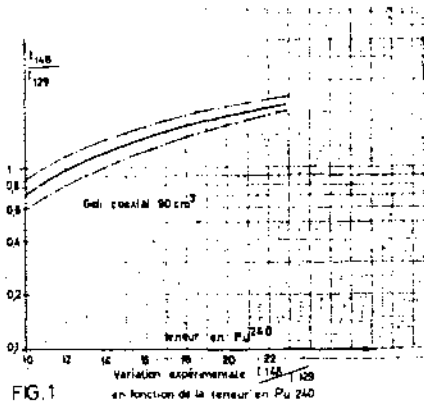

FIG.1

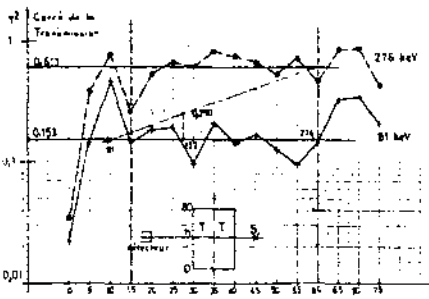

FIG.4

TRANSMISSION D'un Fuf contenant du Pu 239 en fonction de la position de la source de Ba par rapport à la base du fuf

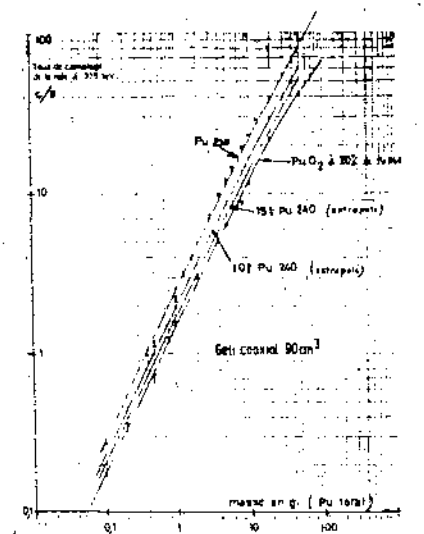

FIG.2 ETALONNAGE EN PLUTONIUM

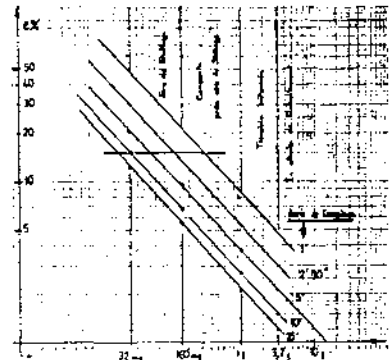

FIG.5

VARIATION DE L'ERREUR STATISTIQUE en fonction de la masse de Pu et du temps de comptage

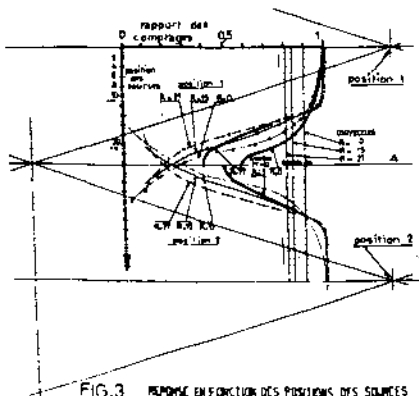

FIG.3 REPOSSE EN FONCTION DES POSITIONS DES SOURCES

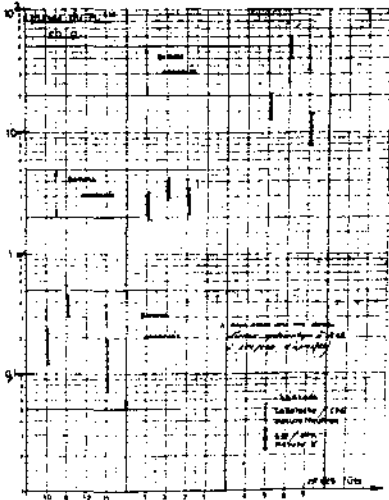

FIG.6

COMPARAISON mesure par Géométrie (SPR/BG) mesure par neutron (PC/LAG)

TRAITEMENT DES DONNEES NUCLEAIRES APPLIQUE  
A LA RADIOPROTECTION A L'AIDE D'UN  
MINIORDINATEUR MULTI 20

C. LASSEUR - G. TROESCH - J. GAUDIAU

COMMISSARIAT A L'ENERGIE ATOMIQUE

Centre d'Etudes Nucléaires de Fontenay-aux-Roses  
Service de Protection contre les  
Rayonnements

## 1. INTRODUCTION

L'exercice de la radioprotection auprès des installations nucléaires et de leur environnement repose toujours sur la bonne connaissance et le suivi de grandeurs caractéristiques du niveau de radioactivité : dose et débits de dose absorbée, activités volumiques ou surfaciques, exposition subie... Qu'il s'agisse de fonctionnement normal ou de situation évolutive, ces grandeurs sont déterminées à partir de mesures spécifiques et présentant un caractère répétitif. Il peut s'agir d'opérations simples de mesure d'activité sur échantillon ou d'analyses plus complexes pour la connaissance des radionucléides ou la spectrométrie du champ de rayonnement. Mais l'exploitation des mesures est souvent longue et fastidieuse. Le développement et l'utilisation de plus en plus répandus des moyens informatiques permettent un traitement plus rapide des résultats de mesure ce qui conduit à une radioprotection mieux adaptée et plus efficace.

En 1975, le Service de Protection contre les Rayonnements du CEN.FAR s'est doté d'un système programmé pour l'analyse en ligne des données nucléaires avec exploitation continue depuis Janvier 1976. Nous allons décrire ce système et mettre en évidence ses avantages et ses inconvénients pour une utilisation centralisée appliquée à la radioprotection.

L'emploi actuel porte sur :

- l'identification de radionucléides et les mesures d'activité par spectrométrie  $\gamma$  (600 analyses par an)
- la dosimétrie en cas d'accident de criticité
- le contrôle de la contamination de l'air des installations (450 prélèvements sur filtres par jour)

## 2. PRESENTATION DU MINIORDINATEUR

L'ensemble informatique est bâti autour d'un système de base PLURIMAT 20 INTERTECHNIQUE. Le synoptique de la chaîne est représenté sur la planche donnée en annexe, où figurent les caractéristiques essentielles de chaque élément composite.

## 3. TRAITEMENT DE DONNEES NUCLEAIRES APPLIQUE A LA RADIOPROTECTION

Les mesures effectuées pour la radioprotection sont de deux types :

- après incident ou accident
- de routine

Dans le premier cas, le facteur "temps" joue un rôle essentiel car des décisions sont à prendre rapidement, décisions qui sont fonction des caractéristiques de l'accident : nature et intensité du champ de rayonnement et de l'exposition subie par le personnel... Ces caractéristiques sont déterminées à partir de mesures dont l'exploitation doit être aussi rapide que possible. Dans le cas des mesures de routine, c'est le nombre de résultats à traiter qui est le critère déterminant pour le choix des types d'exploitation à utiliser. Dans les deux cas, l'emploi du miniordinateur apporte une solution intéressante pour la radioprotection.

### 3.1. Identification de radionucléides et mesure d'activité par spectrométrie $\gamma$ (1)

Nous avons réalisé un dispositif de traitement automatique de spectres. Le schéma de principe est donné ci-après :

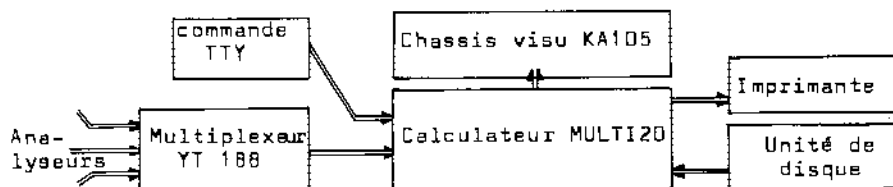

Les impulsions électriques issues d'un semicteur du type GeLi sont stockées dans un analyseur 4000 canaux SA 44, puis transférées sur le MULTI 20 dont le programme de traitement PND5A/026C fournit en sortie le nom des radionucléides identifiés et leur activité. En moyenne, le temps de traitement d'un spectre est de 30 s.

### 3.2. Dosimétrie en cas d'accident de criticité (2)

La dosimétrie en cas d'accident de criticité s'effectue à l'aide de détecteurs de zones, type SNAC (spectromètre neutron à activation). Après comptage des différents détecteurs, les résultats de mesure, sous forme de bandes perforées, sont traités par mini-ordinateur. Les grandeurs de sortie sont les valeurs des fluences de neutrons, de photons ainsi que les doses absorbées engendrées par l'excursion de criticité. Le schéma de principe de traitement est le suivant :

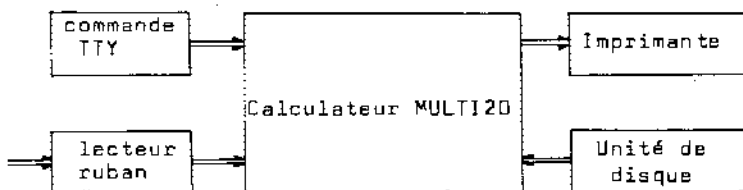

On peut estimer à 10 minutes le temps de traitement global pour huit détecteurs SNAC, depuis la lecture de la bande jusqu'à la sortie des résultats alors que la durée de l'exploitation manuelle correspondante est d'environ une demi-journée.

### 3.3. Contrôle de la contamination atmosphérique d'installation (3)

Le contrôle de la contamination de l'air des installations est effectué à partir des mesures d'activité déposée sur des filtres. Les résultats de comptage de ces filtres sont exploités par une chaîne informatique. En sortie les résultats apparaissent sous forme de "liste" où sont consignés les équivalents en nombre de CMA  $\alpha$  et  $\beta$  de la contamination atmosphérique déterminée aux différents points de mesure. Actuellement 450 filtres sont analysés journalièrement dont les résultats sont gardés en mémoire pour le cumul des statistiques mensuelles.

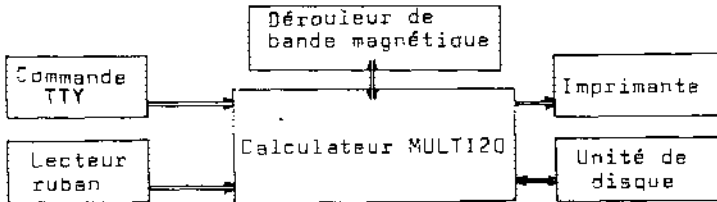

### 4. CONCLUSION

En matière de sécurité, il est séduisant pour l'autorité de décision de pouvoir disposer de moyens permettant une exploitation prioritaire, rapide et centralisée des résultats de mesure. Les outils informatiques et plus précisément l'utilisation de mini-ordinateur constituent une solution élégante, bien adaptée aux problèmes de la radioprotection.

Notre dispositif, en exploitation continu depuis 1976, donne entière satisfaction aussi bien dans le traitement des mesures de routine que de celles après accident. Etant donné les capacités de traitement offertes et pour rentabiliser au maximum la chaîne, nous envisageons de l'adapter à la gestion des déchets solides radioactifs avant stockage définitif, la surveillance et le contrôle du site et de l'environnement.

### REFERENCES

- (1) VABRE B. Analyse automatique de spectres. Compagnie Générale de Micromatique (1975)
- (2) SENTENAC J.P. Traitement automatique à l'aide d'un mini-ordinateur MULTI 20 des données issues des dosimètres de criticité. Rapport de stage (1975)
- (3) GAUDIAU J. Notice d'emploi du programme RA 15. SPR/SMSR NR 77/3 (1977)

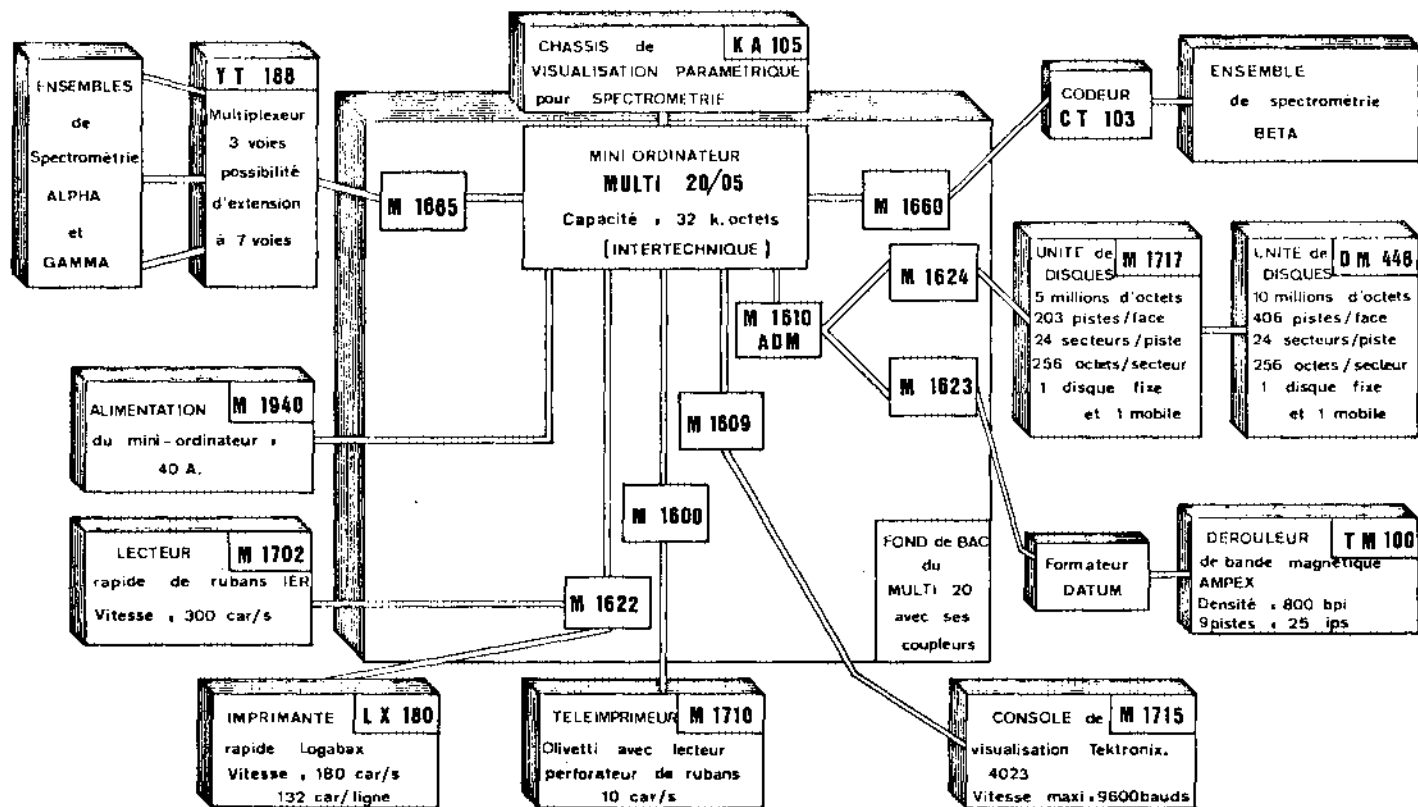

*Tableau synoptique du matériel de traitement de l'information.*

## LES MICROPROCESSEURS DANS LES APPAREILS DE RADIOPROTECTION

Auteurs : M. TRAVAILLON Raymond  
M. PALLEES Alain

SPR/CEN SACLAY  
MERTIX GERIN - GRENOBLE

## 1. INTERET DE DISPOSER D'UN TRAITEMENT ELABORE DE L'INFORMATION

Les capteurs de radioprotection envoient en permanence, et de façon imprévisible, des impulsions électriques à l'ensemble de traitement. La fréquence (F) de ces impulsions est une fonction plus ou moins complexe de la grandeur nucléaire (N) contrôlée (N représente le nombre de limite maximale admissible L.M.A.).

La relation générale est  $F = f_{k_i}(N)$  où  $k_i$  représente des paramètres dépendant du capteur et de la grandeur nucléaire contrôlée, soit :

- en irradiation

- . paramètre de sensibilité : nombre d'impulsion par mRem
- . facteur de position capteur/travailleur

- en contamination

- . paramètre de rendement détecteur-filtration
- . paramètre de radiotoxicité
- . facteur de position capteur/travailleur

Le résultat qui intéresse l'exploitant est :  $N = f^{-1}_{k_i}(F)$

Dans la plupart des cas, cette fonction est, très approximativement, une relation de proportionnalité dont le coefficient dépend de  $k_i$  (irradiation, contamination gaz et liquide). Dans le cas des capteurs aérosols à filtre fixe où l'activité est cumulée sur le filtre, la relation est, approximativement :

$$N = (x_i) \Delta F / \Delta T$$

(c'est l'accroissement de fréquence des impulsions capteur qui est significatif du niveau de contamination de l'air).

Les fonctions de proportionnalité sont relativement aisées à mettre en oeuvre en technologie câblée (soit par division, soit par adaptation du temps de mesure), alors que le traitement de la contamination en aérosols est extrêmement lourd. Il devient aisé en technologie programmée car alors la complexité n'existe qu'au niveau du logiciel et non plus au niveau du matériel.

Il apparaît donc que les appareils ayant la capacité de résoudre les différents cas de la radioprotection sont nécessairement programmés.

## 2. RAPPEL SUR LES INSTALLATIONS A CALCULATEURS

Les TCR utilisant un ordinateur central (par exemple Bâtiment 120 - CEA Centre de Saclay) permettent d'obtenir l'information élaborée, exprimée en LMA, ainsi que le cumul des doses par poste de travail. Le fait de disposer de cette information permet d'obtenir des signalisations plus représentatives des niveaux de danger pour les personnes que dans le cas des TCR traditionnels

Dans les TCR à calculateur actuellement en service, le capteur est associé à un coffret de signalisation pour former une balise. Les consignes de signalisations sont issues du TCR. Néanmoins, pour certaines défaillances du centralisateur, une signalisation de secours (signalisation réduite) est automatiquement mise en service dans le coffret de signalisation. Ainsi la fonction sécurité, bien que dégradée en qualité, est assurée, cependant que la fonction mesure est perdue pour l'ensemble des balises.

L'utilisation d'un microprocesseur par balise permet de pallier cet inconvénient tout en conservant l'intégralité des résultats qui étaient élaborés par le calculateur pour la balise considérée.

### 3. ORGANISATION D'UNE BALISE A MICROPROCESSEUR (fig. 1)

L'électronique du capteur assure uniquement l'alimentation du détecteur et la mise en forme de son signal. Le coffret de traitement-signalisation (CTS) associé comprend :

- l'unité de traitement (microprocesseur) constituée de :

- . l'horloge
- . l'unité logique et arithmétique
- . la mémoire active (mémoire RAM de travail)
- . la mémoire programmable (mémoire PROM contenant le programme de la balise)
- . le contrôleur d'interruption

- les systèmes "périphériques"

- . le compteur d'impulsions
- . les organes de réglages des paramètres (ki) et des seuils
- . le système de signalisation et de visualisation
- . la transmission asynchrone (liaison vers le centralisateur)
- . le système de test du coffret
- . le système de conversion analogique (sortie enregistreur)

- l'ensemble de ces circuits est organisé autour de trois "bus" :

- . le bus adresse
- . le bus de données
- . le bus de contrôle

Les organes de réglage des paramètres ki et des seuils sont constitués de commutateurs.

La mesure est visualisée à l'aide d'afficheurs optoélectroniques à 7 segments, et elle est traduite analogiquement (sortie logarithmique).

Les organes de signalisations spécifiques à chaque niveau d'alarme sont montés sur la porte du coffret (signalisations lumineuses et sonores).

L'état des alarmes est disponible sous forme de contact de relais.

Les balises actuellement existantes, balises électrons et photons, balise neutrons, balise gaz, balise aérosols, sont réalisées en montant dans le coffret CTS le programme adapté à chaque capteur.

#### 4. FONCTIONNEMENT DE LA BALISE A MICROPROCESSEUR (fig. 1)

Le compteur d'entrée du coffret CTS stocke les impulsions venant du capteur. Son contenu est lu toutes les secondes par l'unité de traitement (UT) et il est utilisé conformément au programme contenu dans les mémoires PROM et aux valeurs des paramètres.

L'UT calcule les débits de "dose" ainsi que l'intégrale de ce débit (cumul de dose).

A la fin de chaque cycle de mesure, le débit de "dose" est comparé aux valeurs des seuils et, s'il est supérieur, la signalisation correspondante est actionnée (dès qu'un seuil est dépassé, le programme diminue automatiquement sa valeur ; on réalise ainsi une hystérésis programmée). Les signaux nécessaires à la signalisation sont élaborés par des générateurs programmés par l'UT. Après comparaison du débit de dose aux différents seuils, l'UT calcule son logarithme qui est ensuite transmis au système de conversion analogique.

Une sécurité existante fait que, si le débit de "dose" décroît brutalement, la nouvelle valeur sera atteinte d'une manière hyperbolique (si la période des impulsions d'entrée est supérieure à un temps  $t$ , le débit de dose est inférieur à  $k/t$  :  $k$  est un coefficient calculé à partir des  $k_i$  : balise d'irradiation).

Le résultat visualisé à l'aide d'afficheurs optoélectroniques est le débit de dose et, sur demande manuelle, le cumul de dose est temporairement affiché.

L'ensemble des valeurs (paramètres, seuils, débit de dose, cumul de dose et état des alarmes) est automatiquement émis par l'intermédiaire du système de transmission asynchrone à chaque changement d'état des alarmes et sur interrogation externe (la balise possède une adresse câblée).

#### 5. AVANTAGES DES BALISES A MICROPROCESSEUR

Les avantages des balises à microprocesseur résident en ce qu'elles réalisent toutes les fonctions assurées par le calculateur dans un système centralisé, en particulier elles permettent de déterminer en temps réel, les débits de "dose" auxquels sont soumis les personnes à leur poste de travail.

Par ailleurs, l'utilisation d'un microprocesseur par balise élimine les pertes de mode commun introduites par un calculateur unique. On obtient ainsi une plus grande sûreté de fonctionnement de l'installation.

Enfin, il existe d'autres avantages, soit :

- amélioration de la fiabilité des balises par une plus grande intégration des fonctions (remplacement de toute fonction câblée par son équivalente programmée)

- facilité d'installation et de câblage car le câble "mesure" n'existe qu'entre capteur et coffret et non plus entre balise et ECR. La liaison avec le ECR s'effectue par une seule paire blindée

- affichage direct de la mesure en LMA, c'est-à-dire un nombre représentant soit des mRem/h, soit des  $\mu\text{Ci}/\text{m}^3$



- souplesse d'emploi, d'une part car le coffret associé au capteur pour former une balise est banalisé : la spécificité de chaque balise est assurée par les mémoires PROM qui contiennent le programme adapté à chaque capteur (un jeu de PROM par capteur). D'autre part, les balises ainsi réalisées conviennent à tous les types d'installations de radioprotection, quelles que soient leurs tailles.

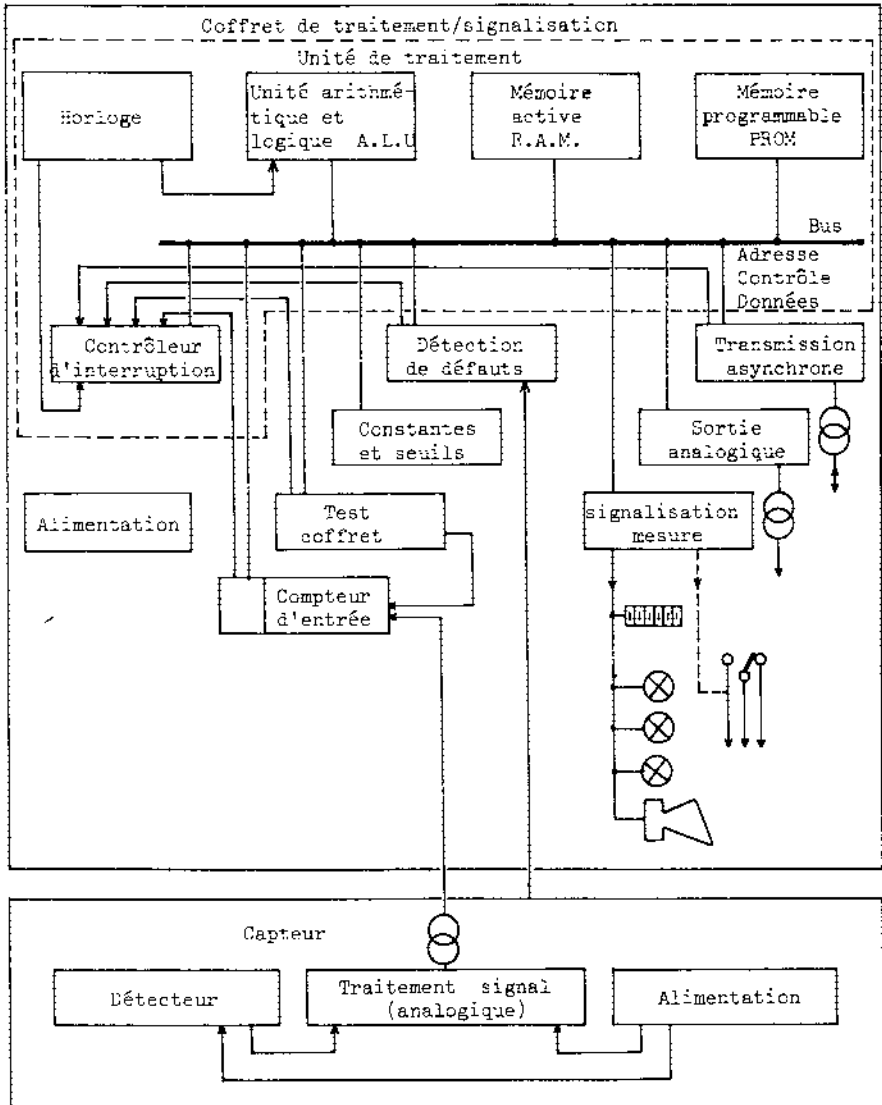

FIG. 1

RADIATION AND CHEMICAL MUTAGENIC AGENTS—  
SHOULD WE HAVE A SINGLE EXPOSURE LIMIT?

M. S. S. Murthy  
Division of Radiological Protection  
Bhabha Atomic Research Centre  
Bombay-400 085, INDIA

1. PROLOGUE

We have been actively concerned with radiation hazard for over 50 years by now. During this period, the standards for radiation exposure have evolved through an unspecific amount such as 1/100th of the skin erythema dose in 30 days (1925), to more specific values such as 0.2 R/day in 1934, to 300 mrem/week in 1954, to 5 rem/year in 1957. The exposure standards have stayed at this level to date. On this evolutionary course an important branching point occurred in 1957 when the genetic effects of radiation were taken into account and ICRP recommended exposure limits to individual members of the population and to the whole population as 0.5 rem/year and 5 rem/30 years respectively. The important point to be emphasised here is that these limits were established without regard for the influence of other environmental factors which might be having similar effects. The carcinogenic effects of chemicals were known even before the discovery of X-rays. As early as in 1940's Auerbach had demonstrated that chemicals such as nitrogen mustard can cause mutations similar to X-rays. It is only now being increasingly realised that man's environment contains, in addition to radiation, a large number of chemical compounds many of which may be carcinogenic and mutagenic. The possibility therefore exists that human beings may simultaneously be exposed to several mutagenic chemicals as well as to radiation. Hence it has become necessary to develop an integrated approach to the problem of environmental mutagenic hazards.

2. RECOMMENDATIONS OF COMMITTEE 17

The Council of the American Environmental Mutagen Society appointed a committee (called the "Committee 17") to review the current status of environmental mutagenesis and to suggest regulatory principles to control human exposure to mutagenic agents. In reviewing the current status of mutagenesis, the Committee (1) has appreciated the idea that the available vast information of radiation mutagenesis should serve as a base to understand and control the mutagenic hazards of other agents. In line with this thinking, the Committee has proposed a unit called "rem-equivalent chemical" (REC) for purposes of quantitating the hazards from chemical agents. REC is defined as "that dose or product of concentration multiplied by the time which produces an amount of genetic damage equal to that produced by 1 rem of chronic irradiation". The Committee has gone one step further to recommend a single limit to the exposure of all man-made mutagenic agents—including chemicals and radiation. In the following paragraphs we will discuss some of the implications of these recommendations on the practice of radiation safety.

The Committee proposed that "the total mutagenic exposure from man-made chemicals as well as radiations (but still excluding medical radiation), expressed, for instance, as the sum of the rems and RECs, be limited to the same extent, namely to the equivalent of 5 rem per generation". The Committee goes on further to state that "while our main concern is necessarily with the average population, we recognise that high risk sub populations also exist, encompassing, for instance, certain industrial and agricultural workers. We therefore recommend that the maximum permissible mutagenic exposure to individuals who are still within the reproductive life-span be limited to a tenfold excess over the average maximum permissible exposure level". Presumably the "high-risk subpopulation" includes radiation workers. Since the limits recommended are to include exposures from radiation and a variety of chemicals, an apportionment has to be made for each type of mutagen. Hence, the Committee recommends "that no single mutagenic agent should be allowed to exceed 10 percent of the 5-REC budget allotted to all mutagenic agents" Since chemical pollution is more ubiquitous than radiation pollution, it can be assumed that all radiation workers (and public) who are exposed to radiation are also exposed to chemical pollutants which are to be controlled

### 3. IMPLICATIONS OF THE RECOMMENDATIONS TO THE PRACTICE OF RADIATION SAFETY

Let us project recommendations of the Committee 17 on to the currently practised radiation safety standards. The Committee recommends that human exposure to all types of mutagens be limited to 5 REC per generation (30 years). This works out to be 0.17 REC/year<sup>(2)</sup>. For radiation workers the recommended level will be 1.7 REC/year, since a tenfold increase over the population level is permitted. However, in a composite environment, since only 10 percent of the 5 REC budget is allowed for each type of mutagen, the suggested level of radiation would be 0.017 and 0.17 rem per year for the general population and radiation worker respectively. These values are summarised in Table 1. Comparison with the currently accepted ICRP recommendations shows that the radiation exposure to general public and occupational worker be reduced by factors of 10 and 30 respectively. It may be noted that WEINBERG and ADLER also have suggested in a U. S. Congressional Testimony that the additional human exposure to radiation be restricted to not more than the standard deviation of the natural background radiation. This is about 20 mrem/year (see ref. 3). If it is rational to say that occupational exposure must be limited to 10 times this level (i. e. to 200 mrem/year), recommendations of the Committee 17 are in agreement with the suggestion by WEINBERG and ADLER.

Now let us take a critical look at the basis of the current radiation safety standards and risk-estimates before considering the adequacy of these standards in the presence of other environmental mutagens. We are interested in the genetic and somatic risks from exposures of 5 rems and 150 rems spread out over 30 years. The exposure pattern may vary from chronic and continuous to fractionated pulses of high intensity or a combination of both. Data available for risk estimation pertain to doses of a few hundreds of rads or higher given over a short interval of

time. These are extrapolated to low doses on the basis of a linear hypothesis in order to estimate the risk at low doses of interest in radiation safety. The linear hypothesis, which has been favoured because of its conservative nature, has come into severe criticism in recent years, since it does not take into account two important factors. First, the biological system has repair and selection capacity to guard against somatic and genetic insults. It is known that doses delivered in small fractions and protracted over a long interval of time are less effective than equivalent single doses given over a short interval of time. The time-scale in the available data and the time-scale involved in the levels of human exposure at the recommended protection standards differ by several orders of magnitude. Hence, to expect proportionate amount of effect at these doses and dose rates is to ignore the facts of repair and selection. Second, it is known in radiation biology that the latent period in the induction of tumor by radiation is dependent upon dose. JONES et al. (4) have shown that latent period varies as  $D^{-1/3}$  where D is the dose. Similar inverse relationship between latent period and tumour induction has been demonstrated by JACOBI (5) for internal exposures also. Hence, to assume that tumors at low doses would occur with the same latency as those at high doses is to ignore this biological observation. At exposure levels low to be tested experimentally, the tumour may occur late in life, when its socio-economic impact is small or may not appear at all if the latent period is longer than the human life span. In this sense there may even be a "practical threshold" for low level radiation effects. Hence, the risk estimates based on linear hypothesis are known to be conservative: perhaps too conservative.

There are evidences to show that this may be so. We will cite only a few of the recent ones. One set of experimental data which support the risk at low doses is the epidemiological survey by STEWART et al of the children who were exposed to diagnostic X-rays in utero (6). This study showed that among these children the leukaemia risk was about twice the control. Similar studies conducted subsequently supported this view: the risk factor varying from 1.3 to 1.6 (see ref. 7). However, recently OPPENHEIM et al (7) have critically analysed these results and found bias in all these studies. The mothers of these children were x-rayed because of some medical indication. Therefore one may anticipate that the exposed mothers collectively had a higher incidence of medical problems than unexposed mothers. Hence, it would not be surprising if the in utero exposed children, as a group, were less healthy than the control children solely on the basis of factors which led to the X-ray diagnosis. OPPENHEIM et al (7) conducted a similar study in which such bias due to selection was minimal. This study did not show any convincing evidence for the increased risk of leukaemia in children exposed to diagnostic X-rays in utero. MOLE (8) however has observed that twins had been exposed to X-rays in utero 5.5 times more often than singletons. Despite this high selection for X-ray examination, irradiated twins showed no greater incidence of subsequent malignancies than singletons.

On the other hand there are reports which suggest that low doses of radiation may have some beneficial effects in the way of stimulating repair processes. This has been demonstrated in plants (9) and insects (10). PLANEL et al (11) have demonstrated a stimulatory effect on cell multiplication in paramecia by natural background radiation and small

doses of gamma rays from  $^{60}\text{Co}$ . Even though these effects are observed at doses high for human beings, it is possible that such effects can exist at corresponding levels in human beings also. There are evidences of the negative risk at low doses in human population. DELPLA (12) has pointed out that analyses of the incidence of leukaemia among the Japanese atomic bomb survivors indicate that the average risk at doses which are not too high was negative and the effect may actually be beneficial. In a recent epidemiological survey of U. S. population FRIGERIO and STOWE (13) found a negative correlation for mortality rates from all causes, cancer induction and congenital malformation with the increasing natural background radiation. Further, even at the current radiation safety standards, the estimated incidence of chromosome damage (14), birth defects (15) and cancers (5) in the exposed population remain low. In addition to all these considerations, when one looks at the actual radiation dose currently received in practice, it is on the average only 1/10th and 1/40th of the permissible levels for occupational workers and general population respectively. It is further estimated that the average exposure from an extensive world program of nuclear power production would add only a few millirem per year throughout the population (16). Thus, while the frequency of harm such as cancer induction can be estimated for doses of a few hundreds of rads, delivered over a short interval of time, such estimates at doses one thousandth of these levels will be quite uncertain and can be inferred only on a hypothetical basis. Even then such estimates give the maximum injury which may be caused by radiation and thus inherently contain a safety factor.

#### 4. A FISH-EYE-VIEW OF THE ICEBERG

Now, let us briefly look at the chemical scene. Exposure of occupational workers to chemical pollutants take place in industrial processings and manufacturing and in the agricultural use of pesticides and herbicides. Population exposure takes place via the industrial waste disposal, contamination of the processed consumer goods, drugs, pharmaceuticals, cosmetics, food preservatives and additives, burning of fuel and electrical power generation programs. In fact it is estimated that nearly 4 million chemical substances are used by man and many of these may be carcinogenic and mutagenic. Another 500-600 new chemicals are known to enter market every year. Many of these are produced in thousands of tons every year and are widely distributed and used. High levels of several chemical substances such as DDT, lead, mercury etc. have been detected in human tissues. In several cases epidemiological evidences have provided sufficient documentation to positively identify certain industrial chemicals as carcinogens. For example occupational exposure to nickel is known to result in the cancer of lung and nasal cavity. Similarly occupational exposure to vinyl chloride is associated with the cancer of the liver while that of cadmium to result in prostrate and respiratory cancers (17).

Unlike in radiation, there are no universally accepted limits for chemical pollutants. In fact there are fundamental differences in the definitions of the permissible levels. In USSR the maximum allowable concentrations (MAC) of harmful substances in air of the working area is defined as "those concentrations that in the case of daily exposure at work for 8 hours throughout the entire working life, will not cause any diseases or

deviations from a normal state of health detectable by current methods of investigations, either during the work itself or in the long term" (18). This may be compared with the definition of the threshold limit value (TLV) adopted by the American Conference of Governmental Industrial Hygienists. The TLV defines the conditions to which "nearly all workers can be repeatedly exposed, day after day, without adverse effect. Because of the wide variation in individual susceptibility a small percentage of workers may experience discomfort from some substances at concentrations at or below the threshold limit, a smaller percentage may be affected more seriously by aggravation of a pre-existing condition or by development of occupational disease". While the definition of MAC is very similar to that of the maximum permissible doses by the ICRP, the TLV deliberately accepts unfavourable effects and even occupational diseases in individual workers. Because of these fundamental differences in the approach to the problem of setting limits, there are wide differences between the MAC values of the USSR and the TLV values. For example while the TLV for trichloroethylene is  $500 \text{ mg/m}^3$ , the MAC value is  $10 \text{ mg/m}^3$ . The MAC value for vinyl chloride is  $30 \text{ mg/m}^3$  while the limit in Federal Republic of Germany is  $260 \text{ mg/m}^3$ . The TLV of vinyl chloride (U.S.A) has come down from  $1300 \text{ mg/m}^3$  to  $130 \text{ mg/m}^3$  to as low as 1 ppm recently (17). Similarly there are considerable differences in the suggested limits for chlorinated hydrocarbons and metals. Some of these are shown in Table 2.

Another interesting contrast between radiation and chemicals is the differences between the suggested limits and the actual levels found in work-areas. The levels in work-areas are known to be most often higher (some times orders of magnitude higher) than the suggested permissible values. Some of these are shown in Table 2. This is in contrast to radiation where the levels in work-areas, as a rule, are always less than the recommended levels. Further there are not many estimates of risk to human population by exposure to chemical agents. Whatever data available suggest that the situation is quite bad. For example an exposure to ethylene oxide at 5 ppm level for 40 hr/week is estimated to be equivalent to a radiation dose of 4 rads (19). Since 50 ppm is the recommended permissible level in work-areas, this turns out to be equivalent to a weekly radiation exposure to 40 rads. The Committee 17 (1) has estimated that the current consumption of  $\text{NaNO}_2$  by human beings is equivalent to about 8 rem of radiation dose per generation. An estimate of the overall effect of all the chemical pollutants, in terms of radiation dose can also be made. It is known that the "spontaneous" cancer death rate, for most part of the world, ranges between 1000 and 2000 per million per year. It is also suspected that 80-90 percent of these cases are attributable to chemical pollution of the environment (20). The BEIR committee has estimated that the risk of cancer death in a population of 1 million exposed to 1 rem of radiation dose per year is about 100-200/year. Based on these data we can estimate the radiation equivalence of the present level of chemical pollution for cancer induction. Taking the

extremes, this value ranges from 4 to 18 rems. POCHIN (16) has estimated that industrial exposure to chemical agents may result in 10 to 30 cases of cancer death per year in a population of 10,000 workers. Although all these estimates are fraught with uncertainties, they are striking enough to provide a general perspective of the problem of chemical pollution. Compared with the chemical pollution of the environment, radiation hazard is only a tip of the iceberg.

## 5. EPILOGUE

Very little is known about these environmental chemical mutagens. While radiation hazard control has attained an advanced stage, control of chemical mutagens in the environment is still in its infancy. While a disproportionately greater degree of effort and expenses are called for to further reduce radiation levels, great reduction in the levels of chemical mutagens can be achieved by applying elementary principles. Hence at this stage of the art of environmental protection, the question to be asked is "should we have a single exposure limit for both radiation and chemicals and thus be further restrictive in the use of radiation?". It is the author's opinion that such an integrated approach may be required, probably, only when the control of chemical mutagens has reached a stage comparable to that of radiation. Until then it would be prudent to retain the radiation safety standards at the current level. Meanwhile, however, we may strictly adhere to the most basic of all the ICRP recommendations that "all doses be kept as low as readily achievable, economic and social considerations being taken into account". Here we may add, in addition to economic and social considerations, "environmental considerations" also.

Risk group	ICRP (radiation only)	Committee 17		Ratio of radiation levels ICRP/Comm 17
		All mutagenic agents(includ- ing radiations & chemicals)	Radiation only*	
General population	0.17 rem/Y	0.17 REC/Y	0.017 rem/Y	10
Occupat- ional workers	5.0 rem/Y	1.7 REC/Y	0.17 rem/Y	30

\* Values imputed.

TABLE 1: Comparison of the recommendations of the ICRP and Committee 17.

Chemical compound	MAC (Russian)	TLV (U.S.A.)	Measured values in work-areas
Trichloro ethylene	10 mg/m <sup>3</sup>	535 mg/m <sup>3</sup>	An American factory 1076-43,000 mg/m <sup>3</sup> A Japanese factory 135-538 mg/m <sup>3</sup> Near operating room personnel 1.6 to 554 mg/m <sup>3</sup>
Vinyl Chloride	30 mg/m <sup>3</sup>	FDR-260mg/m <sup>3</sup> USA-1300mg/m <sup>3</sup> (until April '74) 130mg/m <sup>3</sup> (until May 74) 1 ppm (since May 74)	Concentration in air in a polymerisation reactor prior to ventilation-7800 mg/m <sup>3</sup> . During scrapping procedure 130-260 mg/m <sup>3</sup> . In a PVC factory 100-800 mg/m <sup>3</sup> . with peaks upto 87,300 mg/m <sup>3</sup> . VC content of PVC 200-400 mg/kg.
Benzo(a)-pyrene	15 mg/ 100 m <sup>3</sup>	-	1-4 ng/m <sup>3</sup> in different cities of world.
Mercury	0.3mg/m <sup>3</sup>	5 mg/m <sup>3</sup>	-
Lindane	0.05mg/m <sup>3</sup>	0.5 mg/m <sup>3</sup>	-
Heptachlore	0.01mg/m <sup>3</sup>	0.5 mg/m <sup>3</sup>	-
Malathion	0.5mg/m <sup>3</sup>	15 mg/m <sup>3</sup>	-

TABLE 2 : Comparison of the MAC (USSR) and TLV (USA) of some chemical pollutants along with some measured levels in work-areas.

Chemical compound	Equivalent radiation dose
Ethylene Oxide 5 ppm/40 hours	4 rem(19)
NaNO <sub>2</sub> (current consumption rate)	8 rem/generation(1)
Overall effect of all chemical pollutants for cancer incidence	4-18 rem/generation
Estimated cancer deaths in chemical industry	10-30/10,000 workers(16)

Several cases of occupational cancer in chemical industries have been reported, while no increase in malignant diseases has been detected in occupations involving radiation exposures with the exception of radium dial painters and uranium mine workers.

TABLE 3 Some estimates of hazards of exposure to chemicals in terms of "equivalent radiation doses".



## REFERENCES

- (1) Environmental mutagenic hazards. Report of the Committee 17. Science 187 (1975) 503.
- (2) MURTHY, M. S. S. "Recommendations of the Committee 17 on environmental mutagenesis: Implications to radiation safety" Health Phys. (1977).
- (3)\* SINCLAIR, W. K. IAEA Symposium Vol. 2 (1976).
- (4)\* JONES, H. B. et al. IAEA Symposium, Vol. 1 (1976).
- (5) JACOBI, W. Third European Congress of the IRPA. Introductory and review papers. (1975) 18.
- (6) STEWART, A. et al. "A survey of childhood malignancies, Brit. Med. J. 1 (1958) 1495.
- (7)\* OPPENHEIM, B. E. et al. IAEA Symposium, Vol. 2 (1976).
- (8) MOLE, R. H. "Antenatal irradiation and childhood cancer causation or coincidence?" Br. J. Cancer 30 (1974) 199.
- (9)\* NIEMANN, E. G. et al. IAEA Symposium, Vol. 1 (1976).
- (10)\* DUCOFF, H. S. IAEA Symposium, Vol. 1 (1976).
- (11)\* PLANEL, G. et al. IAEA Symposium, Vol. 1 (1976).
- (12)\* DELPLA, M. IAEA Symposium Vol. 2 (1976).
- (13)\* FRIGERIO, N. A. and STOWE R. S., IAEA Symposium Vol. 2 (1976).
- (14) LENARD, A., Third European Congress of the IRPA. Introductory and review papers (1975).
- (15) SHANKARANARAYANAN, K. Mutation Res. 35 (1976) 387.
- (16) POCHIN, E. E. Personal Communication.
- (17) International Agency for Research on Cancer, Monographs.
- (18) SANOCKIJ, I. V., "Investigation of new substances: permissible limits and threshold of harmful action". Methods used in the USSR for establishing biologically safe levels of toxic substances, WHO, 1975.
- (19) EHRENBERG, L. Mutation Res. 24, (1974) 83.
- (20) HIGGINSON, J. "Symposium on cancer hazards in the environment" WHO Chronicle 30 (1976) 21.

---

\* Proceedings of a Symposium on Biological and Environmental Effects of low-level Radiation, IAEA 1976.

A COMPARATIVE STUDY OF THE RISKS OF CANCER MORTALITY  
FROM IONIZING RADIATIONS AND CHEMICAL POLLUTANTS

K.G.Vohra  
Bhabha Atomic Research Centre  
Bombay-400 085, India

1. INTRODUCTION

Quantitative information on the risk of cancer mortality associated with ionizing radiations and chemical pollutants is of great value in the planning of major nuclear and chemical operations. Epidemiological and laboratory studies provide sufficient basis for an attempt to bring out such quantitative data for the purpose of planning. The data on cancer mortality caused by ionizing radiations has been developed over the last fifty years and can be used for similar risk estimates for chemicals. No direct study on the late effects of carcinogenic chemicals has ever been carried out.

As early as 1903 it was shown that X-rays can induce leukemia in mice (1). During the following decade, evidence of increased incidence of cancer among radiologists became available. By 1922 it was found that more than 100 early radiologists had died of occupationally produced cancers and leukemia (2). This early experience was associated with very large exposures, and due to paucity of dose measurement techniques, no dose-effect relationships could be established. During the last two decades data on dose-effect relationships became available through animal experiments, but this could not be used directly for human risk estimates, due to very large doses used in such experiments and large differences in the life span and tissue radiosensitivity of the species.

Extensive data on cancer mortality has been compiled based on the studies carried out on the survivors of Hiroshima and Nagasaki, patients who received large doses from X-rays used for the treatment of ankylosing spondylitis, radium dial painters, the radiologists of early days who used X-rays without precautions and patients treated with radioactive iodine for hyperthyroid. Mortality data for the incidence of lung cancer in uranium miners also became available during the last few decades. Several national and international bodies, notably the United Nations Scientific Committee on the Effects of Atomic Radiation (UNSCEAR) and the Committee on the Biological Effects of Ionizing Radiations (BEIR Committee) of USA have made extensive use of the above information to arrive at quantitative risk estimates for ionizing radiations (3, 4), which will be summarised in this paper for comparison with the risks of chemical pollutants.

Induction of cancer by chemical pollutants has also been recognized for a long time, for example, the incidence of scrotal cancer in chimney

sweepers was first reported in 1775, which was later attributed to the presence of the chemical carcinogen benzo(a)pyrene in the coal soot deposited in the chimneys (5). These workers were in the habit of taking off their clothes during work, and prolonged contact with soot often produced cancer of the scrotum. A large number of chemicals have since been recognized as carcinogenic, mainly those belonging to the family of polycyclic hydrocarbons, heavy metals, asbestos, vinyl-chloride and a variety of organic oxides. For quantitative information on cancer deaths from chemicals, data is available for lung cancer mortality and the likely causative agent benzo(a)pyrene for several industrial cities of the world. Systematic information is not available for a large variety of other chemical carcinogens for the quantitative assessment of dose-effect relationships.

The model proposed in this paper is based on the estimates of cancer deaths per man-rem of radiation exposure and finding of rem-dose-equivalents (RDE) for benzo(a)pyrene which has been shown to correlate with lung cancer mortality.

## 2. CANCER INCIDENCE FOR CONTINUOUS PROTRACTED RADIATION EXPOSURES

On the basis of human data for the radiation exposures mentioned in the previous section, the incidence of cancer death per man-rem has been estimated to be around  $200 \times 10^{-6}$ . This estimate is based on the slopes of dose-effect curves for the incidence of leukemia and other cancers in the groups of individuals considered. The types of cancer studied include those of the breast, lung, GI tract including stomach, bone and all other sites. The incidence of mortality from all cancers, including leukemia is estimated to be 6 per rem per year and the total cases of cancer per year including the non fatal cases is estimated to be twice this number (BEIR Committee, 1972). For continuous exposure of 1 rem per year for 30 years the mortality rate is, thus,  $180 \times 10^{-6}$ . This estimate has been rounded off to  $200 \times 10^{-6}$  per man-rem for the equilibrium situation reached after a large population has been continuously exposed to a protracted dose for several years. These estimates are based on the assumption of linear dose-effect relationships for low total doses for which the incidence would be independent of the dose rate. In the dose range actually involved in the human exposures considered, linearity may be assumed on the basis of animal experiments, particularly those with low LET radiations in the dose range of 100 rad. Therefore the above risk estimates should be reasonably valid with the reservation that the target tissue has fairly large radiosensitivity for the induction of cancer. These risk estimates have been used as basis for quantitative comparison with lung cancer mortality produced by benzo(a)pyrene.

## 3. QUANTITATIVE DATA FOR CHEMICAL CARCINOGENESIS

The methods of regression analysis have been generally used for obtaining quantitative data for mortality due to chemical pollutants (6, 7, 8). The basic model may be written as

$$X_i = A_0 + A_1 P_i + A_2 Q_i + e$$

where  $X_i$  is the total cancer mortality rate in the city  $i$ ,  $P_i$  is the mean

concentration of pollutant P and  $Q_i$  is the mean concentration of pollutant Q (or some factor Q) in city  $i$ .  $A_1$  and  $A_2$  are regression parameters in the model and  $e$  is the unknown error term. <sup>2</sup>The regression parameters are estimated by minimising the quantity

$$\sum_{i=1}^n (X_i - A_0 - A_1 P_i - A_2 Q_i)^2$$

The coefficients  $A_1$  and  $A_2$  provide a direct measure of the contribution of the pollutants to the total risk. The validity of the model can be checked by 't' statistics and by 'R<sup>2</sup>' parameter as defined in reference (9). In using the above model it is necessary to use a wide range of the values of X and to ensure that the variables P, Q, etc. are not correlated. For quantitative estimates of the risk of lung cancer, epidemiological data on benzo(a)pyrene and lung cancer incidence has been used in the above model by different authors. For example, Carnow and Meier (8) used the above model for finding the relative contributions of benzo(a)pyrene and cigarette smoking to the incidence of cancer in a population with known lung cancer death rate. They estimated 5% increase in the incidence for an increase of 1 ng/m<sup>3</sup> of benzo(a)pyrene, which will be used here for quantitative comparison with radiation risks. Regression analysis also provided an estimate of the contribution of cigarette smoking. For the estimated contribution of benzo(a)pyrene, the lung cancer incidence would be doubled if the pollutant concentration is increased by 20 ng/m<sup>3</sup>. Similar correlations can be found for different chemical pollutants and the type of cancer they cause if sufficient epidemiological data is available.

#### 4. A COMPARATIVE STUDY OF THE RISKS

We are now in a position to compare the risks of ionizing radiations and chemicals. The total risk of all cancers induced by radiations is  $200 \times 10^{-6}$  per man-rem, as explained earlier. If we take 25% of the total cancers as lung cancers (close to the estimates of BEIR Committee), the risk is  $50 \times 10^{-6}$  per man-rem for whole body exposure.

Cancer of the lung and respiratory tract has been showing a continuous increase in most industrialised cities of the world, and at the current rate, incidence of  $500 \times 10^{-6}$  may be taken as a representative world mean. On the basis of 5% increase per ng/m<sup>3</sup> of benzo(a)pyrene we get 25 additional cases per ng/m<sup>3</sup>. The average benzo(a)pyrene levels in the urban areas are in the range of 1-4 ng/m<sup>3</sup>, the higher value being more prevalent, which would give a contribution of  $100 \times 10^{-6}$  to the lung cancer mortality. So far no standards have been set for benzo(a)pyrene in most countries.

The ICRP radiation dose standards for radionuclides are set at levels that would limit the whole body dose to 500 mrem/year. For this dose to the lung, the lung cancer mortality rate would be  $100 \times 10^{-6}$ , comparable with the estimated current mortality rate for benzo(a)pyrene in the urban areas. This would imply that for even a single carcinogen benzo(a)pyrene the current levels are comparable with the ICRP dose limit for groups and individuals in the population.

Rem dose equivalent (RDE) of benzo(a)pyrene may thus be written as 8 ng/m<sup>3</sup>, corresponding to cancer mortality rate of  $200 \times 10^{-6}$ . In

this context it is important to note that recently "Committee-17" of the Environmental Mutagens Society has suggested a unit called Rem Equivalent Chemical (REC) for quantitative assessment of the genetic effects of all environmental mutagens. Thus REC corresponds to the quantity of chemical substance which produces an amount of genetic damage equal to that produced by one rem of chronic exposure to ionizing radiations in the same test system. As an example, the equivalent lifetime dose for the nitrites, which are mutagenic, could be as high as 8 REC (10). The estimates of REC are generally based on laboratory experiments with simple biological systems. The concept of RDE proposed here could be developed on the basis of epidemiological studies. The proposed RDE concept can be extensively used for different cancers and causative agents, particularly cancers of the breast, bone and GI tract, for which human data on induction by radiations is available. This concept would be of great value in the laying of standards for radiations and chemicals on equivalent risk basis.

Experimental evidence shows that the effects of chemical carcinogens are often synergistic, involving two or more causative agents. For example, benzo(a)pyrene in the presence of heavy metals is known to enhance the effect considerably. Therefore, future studies should include data on both, and regression analysis could then be carried out using a single regression parameter for the product of two pollutants. Such analysis would be valid if the individual pollutants show very little effect but when both are present, the effect is enhanced considerably.

To sum up, this paper has highlighted the type of epidemiological data for chemical pollutants and the data on radiation risk estimates from human experience and animal experiments, which could be used for realistic assessment of the risks of cancer mortality. There is an urgent need for extensive surveys to predict the likely hazards to which the world population could be exposed in the absence of adequate control measures.

#### REFERENCES

1. HEINEKE, H., Muench. Med. Wochsch. 48 (1903) 2089.
2. ROLLESTON, H., Quart. J. Med. 23 (1930) 101.
3. Report of the United Nations Scientific Committee on the Effects of Atomic Radiation, United Nations, New York (1972).
4. Report of the Advisory Committee on the Biological Effects of Ionizing Radiations, National Academy of Sciences, Washington, D.C. (1972).
5. POTT, P., "Chirurgical Observations", Hawes, Clarke and Cullings, London (1775) 63.
6. STOCKS, P., CAMPBELL, J.M., Brit. Med. J. 2 (1955) 923.
7. LAVE, L.B., and SESKIN, E.P., Science, 169, 3947 (1970) 723.
8. CARNOW, B.W., and MEIER, P., Arch. Environ. Health, 27 (1973) 207.
9. DRAPER, N.R., and SMITH, M., "Applied Regression Analysis", Wiley, New York (1966).
10. DRAKE, J.W., Mutation Research, 33 (1975) 65.

RELATIVE BIOLOGICAL EFFECTIVENESS  
OF RADIOACTIVE AND CHEMICAL HARMFUL SUBSTANCES

P.V. Ramzaev, A.A. Zasedatelev, V.M. Kuprianova,  
N.I. Mashneva, K.V. Negrienko, L.F. Rodionova,  
S.Ya. Sukalskaya, V.M. Shubik

Institute of Radiation Hygiene, Leningrad, USSR

Summary

In experiments on mice, rats and water living beings it has been established that the range between threshold and maximum permissible concentrations for radionuclides is 100 times and more as for chemicals.

Under present circumstances when there is almost equal possibility from economic point of view to produce energy by utilization of chemical or nuclear fuel, the problem of relative danger of chemical and radioactive wastes for man and biosphere has key significance. The separate available data and, in particular, conclusions made by Jammet, Bellin et al /1/ allowed to suppose that the relation of acute lethal intake ( $LI_{50/30}$ ) to daily intake (DI) at the limits for population for chemicals is 100-1000 times less than for radioactive substances. The data from our review /2/ on relative danger of chemical substances with known  $LI_{50/30}$  for human organism on the one hand and of radionuclides on the other hand are shown in Table I.

Table I shows that the contemporary limits on intake for population in case of radionuclides are 3-6 orders more safe than in case of chemicals according to the acute lethal index.

The ratios of danger according to many other indices were examined by us in chronic experiments on mice and rats. During all life the animals (50 pieces per one substance and each concentration) consumed drink water contaminated with separate radionuclides or chemicals from 1 to  $10^6$  of maximum permissible concentrations (MPC) for population. Among the investigated substances there were radionuclides:  $^{60}Co$  ( $1,2 \times 10^{-8}$ ),  $^{65}Zn$  ( $1,0 \times 10^{-8}$ ),  $^{90}Sr$  ( $1,3 \times 10^{-10}$ ),  $^{137}Cs$  ( $1,5 \times 10^{-9}$ ),  $^{203}Hg$  ( $6,0 \times 10^{-9}$ ),  $^{210}Pb$  ( $4,0 \times 10^{-11}$ ),  $^{210}Po$  ( $2,4 \times 10^{-11}$ ),  $^{226}Ra$  ( $4,0 \times 10^{-11}$ ) and chemicals: methyl mercury (0,0001), sublimate (0,005), nitrate lead (0,1), strontium (2,0), beryllium (0,0002), hexamethyldiamin (0,01), chlorophoss (0,05). Their MPC's are put in brackets (for radionuclides in Ci and for chemicals in mg per litre of water).

The so-called "threshold concentrations" (TC) for a given number of animals were determined with respect to 14 indices (see Table 2). The obtained results are given as common logarithms for the ratios of TC to MPC.

The range between MPC and TC for radionuclides was found to be average 100 times as much as for chemicals. The sensitivity of all tests used may be considered identical. Only the "atypical cells" and "autoallergy" showed a little higher sensitivity.

The lesser danger of radioactive contamination is particularly evident for water living beings. This has been shown in our experiments when those beings were kept in aquariums contaminated separately by the above radionuclides and chemicals.

The approbated tests and common logarithms of the ratios between MPC and TC are presented in Table 3.

The concentrations of radionuclides 100,000 times higher than MPC turned out to be ineffective for the most of water living beings with the exception of tadpoles. The exception needs a repeated verification. As for chemicals it was enough, as a rule, to keep the concentration on MPC-level or 10 times of MPC for discovering their effects. Death-rate of *Daphnia magna* from chlorophoss increased even below concentration of 0.01 MPC.

Our data confirm the known conclusion, that progress of nuclear energetics leading to decreasing of chemical contamination of the environment is one of the best prophylactic measure from the hygienic point of view.

#### References

- 1 Jammet H., Bellin A., Lacourly G., Beau M., Morbat M. Choix de sites de centrales nucleaires et protection de l'environnement. In: Siting of Nuclear Facilities. IAEA, Vienna, (1975), pp. 335-347.
- 2 Ramzaev P.V., Tarasov S.I. Problem of hygienic estimation of simultaneous intake for different in nature harmful agents. In: Hygienic estimation of radiation and non-radiation factors. Leningrad, (1976), pp. 5-10.

Table I. Comparative danger of chemical and radioactive substances after ingestion

Substance	LI <sub>50/30</sub> of single intake	DI	Ratio of LI <sub>50/30</sub> to DI
<b>I. Chemicals:</b>			
Cyanide of Na,K..	0.12 g	0.2 mg	$6.0 \times 10^2$
Arsenic (As <sup>3+</sup> )	0.12 g	0.1 mg	$1.2 \times 10^3$
Stibium	1.00 g	0.1 mg	$1.0 \times 10^4$
Insecticide DDT	6.00 g	0.2 mg	$3.0 \times 10^4$
Mercury (sublimate)	0.50 g	0.01 mg	$5.0 \times 10^4$
<b>II. Radionuclides:</b>			
<sup>137</sup> Cs	210 mCi	$3.3 \times 10^{-9}$ Ci	$6.4 \times 10^7$
<sup>3</sup> H	70 Ci	$7.0 \times 10^{-7}$ Ci	$1.0 \times 10^8$
<sup>90</sup> Sr	70 mCi	$2.6 \times 10^{-10}$ Ci	$2.6 \times 10^8$
<sup>226</sup> Ra	35 mCi	$0.79 \times 10^{-10}$ Ci	$4.3 \times 10^8$

Table 2. Common logarithms for ratios of the threshold concentration to maximum permissible concentration of radionuclides and chemicals

Biological test	log of ratios for radionuclides	log of ratios for chemicals
Life time	4.8	3.0
Function of nervous system (threshold of sensitivity)	4.1	2.2
Physical endurance (running)	5.0	2.5
Function of reproduction:		
- menstrual cycle	4.7	2.1
- ability for pregnancy	5.0	2.7
- number of new-borns	5.1	2.7
- survival of offsprings	5.8	3.0
Immunologic reactivity:		
- nonspecific immunity	4.4	2.7
- autoallergy	3.7	1.9
Blood test		
- erythrocytes	5.2	2.3
- leucocytes	4.5	2.9
- lymphocytes	4.1	2.8
- neutrophils	4.7	3.0
- atypical cells	3.7	2.5
Average	$4.6 \pm 0.2$	$2.6 \pm 0.1$



Table 3. Estimation of danger to some water living beings from radioactive and chemical substances

Biological test and species	log of ThC/MPC for radio-nuclides	log of ThC/MPC for chemicals (range)
Death-rate of spawn (Coregonus peled Gemelin)	> 5	2 - 0
Larvae abnormalities (Coregonus peled Gemelin)	5	3 - 0
Acceleration of hatching (Coregonus peled Gemelin)	> 5	2 - 0
Death-rate of tadpoles (Rana temporaria)	> 5 - 3	3 - 1
Death-rate of snails (Fissa)	> 5	2 - 1
Death-rate of (Daphnia magna)	> 5	3 - (- 2)
Death-rate of infusorians (Paramecium caudatum)	> 5	4 - 1
Inhibition of microflora (saprophytic)	> 5	4 - 1
Inhibition of biochemical consumption of oxygen	> 5	4 - 1

A RELATIVE RISK ESTIMATION OF EXCESSIVE FREQUENCY  
OF MALIGNANT TUMORS IN POPULATION DUE TO DISCHARGES  
INTO THE ATMOSPHERE FROM FOSSIL-FUEL AND NUCLEAR  
POWER STATIONS

L.A. Ilyin, V.A. Knizhnikov, R.M. Barkhudarov  
Institute of Biophysics, Ministry of Public Health  
of the USSR, Moscow, D-182, Zhivopisanaya, 46

The leading role in environmental pollution belongs to the production of electrical and thermal energy.

Recently there appeared a number of papers dealing with a relative estimation of detriment to the environment and human health due to discharges into the atmosphere from nuclear power stations (NPS) and power stations of traditional type using fossil-fuel (FFPS) (1-6). The estimation of detriment from FFPS is usually performed in these papers basing on the most important components of their discharges, i. e. fly ash, sulfur and nitrogen oxides. However, these papers do not allow one to compare discharges from NPS and FFPS according to similar and clear parameters of detriment since the only currently adopted possible effect of discharges into the atmosphere from NPS is potential risk of excessive frequency of cancer and genetic injury. In some papers an attempt has been made to compare discharges from FFPS and NPS according to adequate parameters, i. e. the degree of radiation exposure of population because discharges from FFPS contain natural radionuclides (2-6). These papers, however fail to consider the whole range of natural radionuclides, and to calculate radiation risk. All this makes comparison more difficult since discharges from FFPS and NPS result in irradiation of different organs and tissues which in addition have various radiosensitivity.

In our paper we made an attempt to estimate radiation risk due to all main natural radionuclides which are contained in discharges from FFPS and to determine risk due to chemical cancerogenic substances released from FFPS. The study was made on the base of the modern Kamensk-Dneprovsk state district power station (SDPS) whose power is 1.200 MW (e) and which operates on coal mined in the Donetz Basin. In addition we used some data obtained at studying the environment around the Shartursk SDPS and the Kokhtla-Yarve FFPS. Radiation exposure of population to gaseous-aerosol discharges of NPS is given from the literary data on water-cooled power reactors (7). It has been estimated that 1 g of fly ash from the Kamensk-Dneprovsk SDPS averagely contains (pCi): radium-226 - 5.0, radium-228 - 3.1, thorium-232 - 5.0, potassium-40 - 50, plumbum-210 - 12.0, polonium-210 - 12.0. The coal content of radon-222 was from 0.3 to 2.0 pCi/g. The calculations were made with allowance for the effect of daughter radionuclides and the accumulation of radionuclides in the environment as a result of the power stations operating for the period of 20 years. Contamination of food products was estimated on the base of air and soil routes of intake. An estimation of radionuclide content in the human body was made by the ratio between radionuclide intake and its con-

tent in the given organ which is characteristic of the natural conditions. The accumulation factor of radium-228 is assumed two times less than that of radium-226. It was also assumed that when coal is being burned all radon which is contained in it was released to the atmosphere. Potassium-40 was considered only as a source of external irradiation (due to homeostatic mechanisms limiting natural potassium intake). Transfer of thorium-232 through the food chains was not considered because of its extremely low absorption from the gastrointestinal tract. At calculating doses to the surrounding population we assumed that all ash released from SDPS ( $1.26 \cdot 10^5$  tons per year) is deposited in the range of 18 km from the station. Calculation of the risk of excessive deaths due to radiation exposure was made on the base of the linear "dose - effect" dependence (8).

The data on radiation exposure of the population in the USSR living near NPS are given in Table 1.

Critical organ	RADIATION DOSE DUE TO RADIONUCLIDE				
	$^{137}\text{Cs}$	$^{90}\text{Sr}$	$^{131}\text{I}^{**}$	Inert radioactive gases <sup>**</sup>	$\Sigma$
The whole body	0.004	-	-	0.36	0.36
Bone tissue	-	0.29	-	-	0.29
Thyroid*	-	-	2.2	-	2.2
Bone marrow	-	0.02	-	-	0.02

\* Dose to the infants younger than 1 year.

\*\* Dose at the border of the sanitary-protective zone.

TABLE 1 Mean Individual Radiation Doses to Individuals From the Population of the USSR due to the Actual Radioactive Discharges From NPS in 1975 (mrem/year per  $10^5$  MW (e))

The data on radiation exposure of the population living near FFPS are given in Table 2.

The absorbed doses due to long-lived radionuclides given in Tables 1 and 2 result from the continuous 20-year-operation period of power stations. Comparative data on the radiation risk for the population living near power stations are given in Table 3.

The data of Table 3 indicate that the radiation risk to the population living near NPS (on condition of their normal operation) is about 30 times less than that to the population living near FFPS. This ratio is also valid for high-power boiling reactors though their discharges of  $^{131}\text{I}$  are increas-

Critical organ	RADIATION DOSE DUE TO RADIONUCLIDE						
	$^{226}\text{Ra}$	$^{228}\text{Ra}$	$^{210}\text{Pb}$	$^{210}\text{Po}$	$^{232}\text{Th}$	$^{40}\text{K}$	$\Sigma$
Bone tissue	0.74	0.002	19.3	93.0	-	0.45	113.8
Bone marrow	0.05	$5 \cdot 10^{-4}$	1.9	13.1	-	0.45	14.5
Lungs	0.71	0.1	1.44	0.88	37.8	0.45	41.4
The whole body	-	-	-	-	-	0.53	0.53

TABLE 2 Mean Individual Radiation Doses to the Population Living near FFPS Operating on Cool (mrem/year per  $10^3$  MW (e))

CAUSE OF DEATH	FFPS	NPS
Leucosis	$4.4 \cdot 10^{-2}$	$5.5 \cdot 10^{-5}$
Bone tumors	$1.1 \cdot 10^{-2}$	$2.9 \cdot 10^{-5}$
Lung tumors	$1.7 \cdot 10^{-1}$	-
Various types of tumors due to whole body irradiation	$1.1 \cdot 10^{+2}$	$7.5 \cdot 10^{+3}$
Thyroid tumors*	-	$3.6 \cdot 10^{-5}$
All above causes	$2.4 \cdot 10^{-1}$	$7.6 \cdot 10^{-3}$

\* With allowance for the dose distribution according to age.

TABLE 3 The Risk of Increased Mortality for the Population Living Near NPS and Coal FFPS From Malignant Neoplasms due to Irradiation (lethal cases per  $10^5$  population per year with the power of  $10^3$  MW (e))

ed risk of lung cancer which may be caused in the vicinity of FFPS by radionuclides penetrating the lungs with ashes. The dose to the lungs from fly ash is calculated on the assumption that 100% of the particles reach (due to high dispersion) lung alveoli. But the risk due to both the effect of radium-226, plumbum-210 and polonium-210 penetrating the body with food products and the irradiation of the whole body by potassium-40 accumulating on the soil is also increased near FFPS. It is to note that the absolute value of radiation risk (resulting from discharges) to the population living near power stations is not large in both cases. In the case of the population group of  $10^5$  persons living near FFPS it can be (theoretically) expected that about 15 additional death cases from cancer will occur during life of one generation (with the mortality level from spontaneous cancer during this time period being  $1.5 \cdot 10^3$ ) (10), while in the case of the same population living near NPS not a single case of additional cancer is expected.

The corresponding calculations made for FFPS operating on black oil show that irradiation of bone tissue and bone marrow and lungs due to their discharges is 5 and 30 times less per power unit respectively than the corresponding values due to discharges from FFPS operating on coal.

It is known that not only radionuclides but also chemical substances contained in the discharges from FFPS may be cancerogenic. The most well known and active among the latter substances is 3,4-benzopyrene (3,4-BP). We determined the content of this substance in fly ash released from FFPS of several types. Depending on the fuel type and the character of its burning the content of BP in ash ranged from 0.14  $\mu\text{g}/\text{kg}$  (Donetz coal ash at the Kamensk-Dneprovsk SDPS) - 0.17  $\mu\text{g}/\text{kg}$  (peaty ash from the Shaturusk SDPS) to 1870  $\mu\text{g}/\text{kg}$  (shale ash from the Kokhtla-Yarve FFPS). The greatest content of BP is observed when the fuel burning is not complete which is the case at less modern and low-powered FFPS. The estimated content of 3,4-BP (due to fly ash from FFPS) in the air of the Kokhtla-Yarve city calculated on the assumption that the dust content in the air of the city is at the level of maximum-permissible dust concentration (0.15  $\text{mg}/\text{m}^3$ ) and the possible risk of additional deaths from lung cancer determined from the study (11) are given below: concentration of 3,4-BP in the air due to fly ash from FFPS - 0.028  $\mu\text{g}/\text{m}^3$ ; risk of increased morbidity corresponding to the 3,4-BP concentration of 0.1  $\mu\text{g}/\text{m}^3$  (cases per year) - 13 per 10<sup>5</sup> of population; risk due to 3,4-BP content in the air - 3.6·10<sup>5</sup> of population; dose of lung irradiation which induces the risk equal to the risk from 3,4-BP in the discharges - 1 rem/year; actual lung cancer rate at Kokhtla-Yarve in 1970 (10) - 34 per 10<sup>5</sup> of population. The data on the risk from 3,4-BP should be regarded as tentative ones because data characterizing the "dose - effect" dependence of this substance are not available. These data are rather conventional but they make it possible to estimate that the risk due to 3,4-BP in discharges from FFPS is probably much more significant than the summary risk from all types of irradiation to which the population is subjected due to contamination of the environment by radionuclides. If the burning of coal is more complete as it is the case at modern FFPS the risk from 3,4-BP will be negligible. However, it should be noted that fly ash from coal FFPS contains iron oxides and oxides of other metals. Our experiments on mice with inhalation route of iron oxide intake (2.5 mg per mouse) showed that this substance could cause lung cancer in the majority of animals. Some data on high cancerogenic activity of nickel are available. Nickel as well as vanadium, silver, iron and other metals are contained in large quantities in ash of FFPS operating on black oil. In the ash of oil from different deposits there are from 2.5 to 36% of nickel and up to 74% of vanadium (12).

### Conclusions

The risk of excessive deaths from malignant tumors in population living near NPS is practically negligible ( $\approx 10^{-2}$  cases per year per 10<sup>5</sup> persons). This risk is about 30 times less than the risk from radionuclides contained in discharges from FFPS operating on coal.

Discharges from FFPS operating on coal and black oil contain metals and chemical cancerogenic substances causing additional risk which often significantly exceeds the risk from radioactive components of discharges. \*

#### REFERENCES

- (1) ВСПАЭЛЬ, Н.А., ТЕВЕРОВСКИЙ, Э.А., Атомная энергия 31  
4 (1971) 423
- (2) EISENBUD, M., PESTOV, H.I., Science 144 (1964) 228
- (3) MARTIN, I.E., et al., "Radioactivity from fossil-fuel and nuclear power station", Environmental Aspects of Nuclear Power Station (Proc. Symp. New York, 1970) IAEA, Vienna (1971) 325
- (4) JAWOROWSKY, Z., et al., "Radiation hazards of the population resulting from conventional and nuclear electric power production", Environmental Surveillance around Nuclear Installation (Proc. Symp. Warsaw, 1973) 1, IAEA, Vienna (1974) 403
- (5) NISHIWAKI, et al., "Atmospheric contamination of industrial areas including fossil fuel power station and a method of evaluating possible effects on inhabitants", Environmental Aspects of Nuclear Power Station (Proc. Symp. New York, 1970) IAEA, Vienna (1971) 247
- (6) JAWOROWSKI, Z., BILKIEWICZ, I., ROMNACKA, L., et al., "Artificial sources of natural radionuclides in environment", 2nd Int. Symp. Natural Radiation Environment, USAEC Symp. Sci. (1975)
- (7) BURNAZYAN, A.I., VOROBYEV, E.I., ILYIN, L.A., et al., "Evaluation, prediction and regulation of radiation doses to the population due to operation of nuclear power stations in the USSR" (the report IAEA-SN-36/351 submitted to the Int. Conf. on nuclear energy and its fuel cycle, Salzburg, Austria, May 2-13, 1977)
- (8) Natural Radiation Sources. Rep. UNSCEAR I/AC, 82/R, 297 (1975)
- (9) SAUROV, M.M., KNIZHNIKOV, V.A., TURKIN, A.D., "Modern problems and some new concepts in regulation of radiation exposure of radiation workers and population", Population Dose Evaluation and Standards for Man and His Environment (Proc. Symp.) IAEA, Vienna (1974) 277
- (10) Заболеваемость населения СССР злокачественными новообразованиями и смертность от них, Медицина, Москва, 1970
- (11) ЯНУШЕВА, Н.Я., Гигиена и санитария 6 (1972) 87
- (12) ДОБРЯНСКИЙ, А.Ф., Химия Нефти, Ленинград, 1961

ESSAI EN VUE D'UNE CONCEPTION GENERALE POUR L'ETUDE DES EFFETS  
RESPECTIFS DE L'EXPOSITION AUX RAYONNEMENTS IONISANTS ET A DES  
POLLUANTS D'AUTRES TYPES

R. BITTEL

Commissariat à l'Energie Atomique, Département de  
Protection, B.P. n° 6 - 92260 FONTENAY-aux-ROSES

ABSTRACT

An approach to a comparative quantitative study of the respective effects of ionising radiations and a number of chemical pollutants showed that chemical pollutants often come into play by formation of free radicals, just as ionizing radiations do. The steps leading to the concept of a common unit of action and detriment are discussed.

1. INTRODUCTION

L'une des difficultés pour une évaluation comparative des effets respectifs d'une exposition aux rayonnements ionisants, d'une part, et aux pollutions chimiques, d'autre part, est de manquer d'unités communes d'action. Les premiers agissent sur la matière par l'énergie qu'ils délivrent aux tissus, énergie caractéristique de l'émetteur, les effets restant fonction de la radiosensibilité des différents tissus. D'autre part, les doses d'irradiation provenant de plusieurs émetteurs sont considérées comme additives. La situation est, en apparence au moins, tout autre, en ce qui concerne les pollutions chimiques : dans ce cas, les modalités d'atteinte des tissus paraissent variées ; en général, les effets ne sont pas additifs, car il existe des synergies et des antagonismes dont les mécanismes sont souvent mal connus. Pourtant, l'examen critique des documents scientifiques disponibles montre que beaucoup de composés chimiques déversés dans le milieu induisent la formation de radicaux libres, comme c'est le cas des radiations ionisantes (1).

L'objet de la présente communication est de contribuer à l'élaboration d'une conception générale pour évaluer comparativement, d'une part, les effets des rayonnements ionisants, d'autre part, ceux d'un certain nombre de polluants chimiques induisant des radicaux libres dans les milieux physiques et les milieux biologiques.

2. FORMATION DE RADICAUX LIBRES PAR DES POLLUANTS CHIMIQUES

On se limitera ici à donner quelques exemples particulièrement importants. Parmi les polluants chimiques provoquant la formation de radicaux libres, il faut citer les oxydants en premier lieu et, en particulier, l'oxygène. Il semble paradoxal de considérer l'oxygène comme un polluant ; pourtant tel est bien le cas pour les anaérobies stricts et, dans une moindre mesure, pour les facultatifs. L'agent responsable de la toxicité est le radical superoxyde  $O_2^-$ , produit dans diverses réactions enzymatiques oxydatives. Les organismes supportant

l'oxygène sont munis d'un système enzymatique de défense ; une superoxyde-dismutase et la catalase (2). Par ailleurs, l'oxygène singulet qui, en particulier, résulte de la décomposition de l'eau oxygénée paraît être à l'origine de toute activité bactéricide ou fongicide (3) en formant des hydroperoxydes des constituants nucléiques. L'ozone, constituant normal de l'atmosphère, est produit lors de nombreuses activités humaines. C'est un constituant important des smogs oxydants. Son action sur les membranes cellulaires, notamment au niveau du poumon, implique la formation de radicaux libres d'acides gras insaturés (4). Le fluor et divers radicaux fluorés, le nitrate de peroxyacétyl et le radical peroxyacétyl provoquent également la formation de radicaux libres.

Parmi les composés à action tératogène, mutagène ou cancérogène, il faut citer les nitrosamines trouvées dans divers produits alimentaires (5), des époxydes de carbures polycycliques, la dioxine formée par l'action de la chaleur sur un défoliant très utilisé (2,4,5 T) (6), enfin des composés, telle l'aflatoxine produite par des micro-organismes (7).

### 3. DISCUSSION

La formation de radicaux libres n'est donc pas le seul fait des rayonnements ionisants, c'est aussi celui de l'exposition à un grand nombre de polluants chimiques, qui, malheureusement, sont parmi ceux qui sont les plus fréquents. Il est clair que, quel que soit l'agent physique et chimique inducteur, les radicaux formés sont les mêmes. Les radicaux libres semblent être les médiateurs communs à la base du détriment résultant de l'action de ces agents. Il paraît donc logique, à partir de ces données, de s'orienter vers le concept d'une unité commune d'action, un "équivalent rem" en quelque sorte, ce qui permettrait une évaluation quantitative et comparative des effets d'un grand nombre d'agents de natures différentes. Pratiquement, cette démarche nécessite la mesure des radicaux libres, donc le recours à un appareillage spécialisé et coûteux. En ce qui concerne les organismes du milieu, il peut paraître plus simple de recourir à l'examen des détriments macroscopiques ou microscopiques, voire biochimiques et génétiques, occasionnés par les différents agents de nuisance. La recherche d'organismes tests particulièrement sensibles aux divers agents apparaît alors comme très souhaitable (8).

### REFERENCES

- (1) WANG S.Y. (Ed) Photochemistry and photobiology of nucleic acids. Academic Press, New York (1976)
- (2) FRIDOVICH I. "Oxygen radicals, hydrogen peroxyde and oxygen toxicity". Free radicals in biology (PRYOR W.A. ed). Academic Press New York (1976) vol 1 239-277
- (3) MAUGH (II) T.H. Singlet oxygen : a unique microbial agent in cells. Science 182 (1973) 44-55
- (4) MENZEL D.B. "The role of free radicals in the toxicity of air pollutants" Free radicals in biology (PRYOR W.A. ed), Academic Press, New York (1976) vol.2 181-202
- (5) LENGES J et al. Concernant la toxicité et l'analyse des nitrosamines. Rev. fermentat. Ind. Alimen. 29 6 (1974) 170-181



- (6) JAUBERT A. Le poison de Seveso. *La recherche* 7 (1976) 868-870
- (7) MILLER J.A., MILLER E.C. "The metabolic activation of chemical carcinogens to reactive electrophiles". *Biology of radiation carcinogenesis* (JUHAS J.M. et al, eds), Raven Press, New York (1976) 147-164
- (8) MUDD J.B., KOZLOWSKI I.T. *Responses of plants to air pollution*, Academic Press, New York (1975).

LA RADIOPROTECTION, UN EXEMPLE POUR L'HYGIENE  
INDUSTRIELLE NON NUCLEAIRE

J. CHALABREYSSE

Institut de Protection et Sécurité Nucléaire  
Département de Protection - Laboratoire de  
Surveillance des Nuisances de l'Homme et de  
son Environnement - Commissariat à l'Energie  
Atomique B.P. 38 26700-PIERRELATTE

1 - EXPERIENCE ACQUISE

1.1. Radioprotection

Depuis 1962, j'exerce mon activité professionnelle au Commissariat à l'Energie Atomique (Centre de PIERRELATTE - DROME) où je dirige un Laboratoire dont la mission est d'effectuer les analyses et contrôles relatifs à la Surveillance des travailleurs (Hématologie, Biologie, Toxicologie, Radiotoxicologie Médicales), et à la protection dans les installations et l'environnement (eaux, effluents, sols, animaux, végétaux). Cette Surveillance s'étend sur le Centre de PIERRELATTE, COMURHEX, SFEQ.

1.2 - Hygiène Industrielle

Par ailleurs, depuis 8 ans à présent, dans le cadre des missions de Diversification du Commissariat à l'Energie Atomique (Coopération Industrielle non Nucléaire et Programmes d'Intérêt Général) nous mettons notre expérience, nos moyens, notre potentiel au service des entreprises, des collectivités de travail etc... dans le domaine particulier de l'Hygiène Industrielle (= ensemble des problèmes sanitaires que pose l'Homme au travail), par l'intermédiaire de notre filiale ECOPOP.

Le Laboratoire de PIERRELATTE est agréé, à divers titres, par différents Ministères et organismes officiels (Ministères de la Santé, du Travail, de la Qualité de la Vie, Agence Financière de Bassin Rhône-Méditerranée-Corse). Nous intervenons dans les entreprises industrielles à la demande de leurs Médecins du Travail, des Ingénieurs de Sécurité, des Directeurs d'entreprises, ou des Médecins Inspecteurs Régionaux du Travail et de la Main-d'Oeuvre. Nos interventions consistent à :

- . évaluer le niveau d'exposition des travailleurs aux différentes nuisances professionnelles (physiques et chimiques de toute nature)
- . étudier les postes de travail
- . proposer des solutions ou donner des conseils pour diminuer ou supprimer les nuisances
- . étudier la toxicité des produits manipulés par les travailleurs
- . rechercher de nouveaux procédés de fabrication, ou améliorer ceux existant afin d'atténuer ou supprimer les nuisances.
- . contrôler les rejets d'effluents et la pollution de l'environnement industriel.

Notre expérience, tout en étant relativement récente, s'étend à différentes branches d'industrie (matières plastiques, chimie, métallurgie, électronique, mines etc...) se préoccupe de toutes les nuisances physiques ou chimiques (Mercure, Plomb, Chlorure de vinyle, Amiante, Cadmium, Hydrocarbures benzéniques, Solvants chlorés, etc...) et couvre sensiblement toute la France.

A titre d'exemple nous pouvons citer les quelques interventions suivantes parmi les plus caractéristiques :

- . étude et définition des risques de saturnisme dans 13 entreprises de la

Région Rhône-Alpes utilisant du Stéarate de Plomb.

- . étude, définition des risques et recherche des produits toxiques dans une Société d'eau minérale fabriquant elle-même ses bouteilles en matière plastique à partir du chlorure de vinyle.
- . étude en continu des risques d'inhalation d'oxyde de carbone par le personnel des postes de péages d'autoroutes.
- . étude dans 5 départements du Sud-Est des risques toxicologiques encourus chez les travailleurs agricoles manipulant des pesticides organophosphorés
- . étude des postes de travail dans une entreprise fabriquant des produits réfractaires (hydrocarbures aromatiques, phénols, isocyanates).
- . Définition des risques dûs au Mercure dans une industrie de matériels de précision.

## 2 - COMPARAISON INDUSTRIE NUCLEAIRE ET INDUSTRIE CLASSIQUE

Dans ces conditions, nous pouvons apporter notre contribution à la comparaison d'une part des risques tels qu'ils existent dans la réalité pour les radiotoxiques et pour les composés chimiques classiques et d'autre part à la protection des nuisances professionnelles dans l'industrie nucléaire et dans l'industrie conventionnelle.

### 2.1. Industrie Nucléaire

Si l'on considère l'industrie nucléaire, les risques existant et la protection qui s'exerce on peut affirmer les faits suivants :

- . les risques théoriques liés à la manipulation, l'utilisation, ou la production de composés radioactifs sont réels, particulièrement graves et parfaitement connus.
- . les effets et le métabolisme des radiotoxiques ont été bien étudiés, et sont bien répertoriés.
- . les normes d'exposition et de Surveillance des travailleurs sont bien définies et admises à l'échelon international.
- . la prévention et la protection s'exercent à tous les niveaux depuis la conception de l'installation, et durant tout son fonctionnement.
- . les accidents réels dans l'industrie nucléaire sont très rares.

### 2.2. Industrie classique

Qu'observons-nous dans l'industrie conventionnelle ?

- . les risques auxquels peuvent être soumis les travailleurs sont théoriquement aussi redoutables que dans l'industrie nucléaire (le benzène peut générer des leucémies, le chlorure de vinyle des angiosarcomes du foie, les métaux lourds peuvent provoquer des néphrites etc...)
- . la connaissance exacte des risques est imparfaite et évolue chaque jour ; il suffit de citer le cas du chlorure de vinyle dont la toxicité s'est révélée dans son ampleur au cours de ces dernières années.
- . le métabolisme des toxiques chimiques est partiellement connu tels ceux du Mercure, des Pesticides, des Hydrocarbures etc... Les relations entre les taux d'excrétion urinaire ou fécale et les valeurs absorbées ou stockées dans l'organisme pour un composé chimique classique ne sont ni connues ni quantifiées.
- . les normes professionnelles d'exposition aux toxiques chimiques n'existent pas en France ; on doit utiliser les valeurs proposées par les USA. Il est vrai que la définition de ces normes pose de délicats problèmes que l'on ne rencontre pas pour les radiotoxiques qui ont comme dénominateur commun l'équivalent de dose maximal admissible alors que l'on est bien incapable actuellement de définir un équivalent d'effet chimiotoxique maximal admissible.
- . la Surveillance biologique et toxicologique d'une exposition profession-

nelle à des chimiotoxiques est empirique, et laissée à l'appréciation individuelle de chaque médecin du Travail.

. au stade de la conception des installations, les risques liés aux procédés de fabrication ou aux produits toxiques manipulés ne sont pas le plus souvent pris en compte.

. les risques pour l'environnement industriel sont, à l'heure actuelle, pris en considération dans le domaine des effluents liquides par l'intermédiaire des Agences Financières de Bassin, mais la pollution de l'air n'est pas réglementée.

. les niveaux réels d'exposition des travailleurs aux nuisances professionnelles classiques (Bruit, température, pollution chimique) sont beaucoup plus importants dans l'industrie conventionnelle que dans l'industrie nucléaire. C'est ainsi que nous mesurons dans les urines de travailleurs d'ateliers de décolletage de la Haute-Savoie des taux d'excrétion d'acide trichloroacétique qui atteignent 400 à 600 ng/litre soit plus de 10 fois la limite considérée comme maximale admissible ; en ce qui concerne le mercure, il nous est arrivé de mesurer des excrétions atteignant en Surveillance Systématique, 200 à 300 microgrammes par litre dans des industries des Bouches du Rhône. Les exemples pourraient être cités en très grand nombre.

### 3 - LA RADIOPROTECTION DOIT SERVIR D'EXEMPLE

De cette comparaison on peut tirer les conclusions suivantes :

- l'énergie nucléaire présente des risques incontestables pour les travailleurs. Pour nous qui avons l'expérience depuis 15 ans de ce type d'industrie, nous pouvons affirmer que ces risques sont à l'heure actuelle parfaitement maîtrisés tant au niveau de la prévention que de la protection collective et individuelle. Ceci est fondamental car l'énergie nucléaire n'aurait jamais connu le développement qu'elle connaît à présent si ces risques n'avaient pas été maîtrisés.

- C'est en cela que l'industrie nucléaire doit être un exemple pour l'industrie conventionnelle et la radioprotection servir de modèle à l'Hygiène Industrielle non nucléaire : les méthodes mises en oeuvre dans l'industrie nucléaire pour connaître les risques, les effets, le métabolisme des radiotoxiques, définir les normes d'exposition professionnelle, codifier les procédés, les rythmes de Surveillance biologique et radiotoxicologiques doivent être transposées à l'industrie conventionnelle afin d'améliorer les conditions de travail.

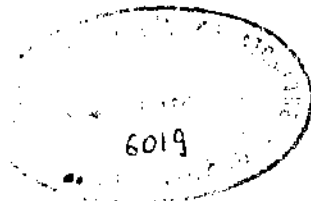

A COMPARISON BETWEEN WORKER DEATHS IN MODERN INDUSTRIES AND IN  
NUCLEAR ACTIVITIES

L. Failla

Chairman of SC/4 "Radioactive Sources" - UNICEN  
c/o CNEN - 125 Viale Regina Margherita - 00198 Rome, Italy

1. INTRODUCTION

Technological progress produces a certain number of human victims through accidents or diseases. The consequences may be fatal, or conditions of illness or disability (temporary or permanent), involving both the present and the future generations. The casualties may be directly connected with production, or linked indirectly to the progress. They may be due substantially to: (1) fortuitous and wholly unforeseeable, and therefore calculable only a posteriori through statistical processes, (2) foreseeable and therefore "preventable" by suitable technical measures and prevention rules, (3) unforeseeable and not previously known, but which become known on occurrence and therefore raise new sets of problems, and (4) foreseeable, calculable and accepted a priori.

With respect to known risks, man can take different attitudes: (a) studying and applying the technical measures required to reduce or eliminate them, regardless of the cost involved, (b) discontinuing the activity or production if the cost exceeds the benefit or if no measures to control them can be found, (c) continuing production while at the same time continuing to seek the necessary measures, and (d) evaluating and accepting the risk up to a certain relation with cost.

This paper is concerned only with fatalities directly connected with production, in both the conventional and nuclear fields. Even with this limitation, however, it is very hard to obtain international statistical data, which we can compare with a fair degree of approximation, because of the great number of variables involved.

After decades of work, the ILO, in the field of conventional industry, has succeeded in furnishing comparable data, but limited to industrial accidents (1). No solution has yet been found, however, for the statistical problem of occupational diseases and of the comparability of the consequences (deaths, permanent and temporary disability) (2) (3).

In the field of nuclear energy, instead, it has proved possible, even though there are still differing opinions, to evaluate with a fair degree of approximation the risk of fatal cancer to the workers in relation to the absorbed doses of ionizing radiations. Based on these evaluations the values of the maximum permissible doses have been set, accepting a risk after having evaluated it. This is, in substance, the case envisaged in point (d) above.

The present difficulty or even impossibility of making a scientifically sound comparison between risks in nuclear industry and in other sectors of production therefore appears evident, even if fatalities alone are considered. It should also be borne in mind that, while in conventional industries the numerical data are recorded among occurred facts (a posteriori), in nuclear industry foreseeable risks are calculated (a priori). It is possible, however, to make certain considerations on the basis of the data available in the literature.

## 2. CONVENTIONAL INDUSTRY

In the area of conventional industry, it has been possible to work out an Italian figure for the period 1965-71 (4). It is an average value of 0.11% deaths due to occupational diseases per year.

As regards deaths due to accidents, developing the ILO data (1) we obtain, on a world-wide level, in the decade 1965-74, the following average percentage annual values for the various industries: mining 0.11, manufacturing 0.019, construction 0.067, railroads 0.045. Average among the various industries: 0.06%.

Extrapolating the above mentioned Italian figure on a world-wide level, we find an annual average of fatal events (by accidents and diseases) of 0.071%.

## 3. NUCLEAR INDUSTRY

From a recent report by E.E. Pochin of AEN-OECD (1976) (5) and from other sources we can extrapolate, based on the main sources and assuming "linearity", the different values of the risk of the number of fatal cancer cases resulting from the maximum permissible dose (5 rem/yr) per 100 workers and per year: 0.02 (excluding thyroid cancers) (ICRP 8, 1965); 0.06 - 0.07 (UNSCEAR Report, 1972); 0.05 - 0.16 (BEIR Report, 1972); 0.05 - 0.1 (5), (6), i.e. within the range of 0.02% minimum to 0.16% maximum. For the total of 40 working years the values range from 0.8% to 6.4%.

As regards the doses received by workers as a result of nuclear accidents, as no significant statistics are yet available, efforts have been made to obtain some information by an indirect process. In the first place, it should be borne in mind that even in serious nuclear accidents a nuclear risk is not necessarily present. A parameter must then be established to detect the presence of this risk: it could be established by exceeding of the maximum permissible dose (5 rem/yr) (8).

From a NRC Report (7) and a recent paper by Baker (8) it appears that, on a total of 85,097 "monitored" workers, employed in the nuclear sector in the U.S. in 1974, 51,806 received unmeasurable doses and 13,760 got doses of less than 0.10 rem and that as few as 262 got more than 5 rem. These cases of overdose involve a total of 1,808 rem, with a death risk ranging, according to the various sources, from  $0.08 \cdot 10^{-3}\%$  and  $0.68 \cdot 10^{-3}\%$ .

#### 4. CONCLUSIONS

By way of information only, and therefore with all of the appropriate reservations, extrapolating Italian data concerning deaths by occupational diseases in the conventional industry and U.S. data on doses to the workers in the nuclear industry to the world situation, the following can be deduced:

Worker deaths in conventional industry, per year:

$$R = \frac{\text{accident deaths per year}}{\text{deaths per year from occupational diseases}} = 0.5$$

Risk of death to workers in nuclear industry, per year:

$$R = \frac{\text{risk of accident death}}{\text{risk of death from occupational diseases}} = 4 \cdot 10^{-3}$$

The basic difference in trends is obviously due to the fact that in the nuclear field the higher risk is contained in the range of doses regarded as acceptable, given the number of workers who may theoretically be exposed to hem. According to Baker (8) and many others, instead, the doses actually received by workers are much lower than those permissible and therefore these values can definitely be lowered, similarly to what has already been done in West Germany (9) and proposed in the U.S. (10).

For the methods of the evaluations, for the completion of conclusions and for complete references of this paper, those interested may wish to read its full text.

#### REFERENCES

- (1) Annuaire des Statistiques du Travail - BIT - Genève (1975).
- (2) International Occupational Safety and Health Congress - BIT - Genève, 30/6-4/7/1969.
- (3) Encyclopedie de Medecine, Hygiene, Sécurité du Travail - BIT, Genève (1974).
- (4) G. Pancheri - Igiene del Lavoro - Bulzoni Editore, Roma (1973).
- (5) E.E. Pochin - Estimation de l'exposition de la population aux rayonnements résultant de la production d'énergie nucléaire et provenant d'autres sources - AEN-OCDE, Janvier (1976).
- (6) Sixth Report Nuclear Power and the Environment - Royal Commission on Environmental Pollution - U.S., September (1976).
- (7) Seventh Annual Occupational Radiation Exposure Report, 1974 - NRC, Report NUREG - 75/108, November (1975).
- (8) K.R. Baker - The Safety of Workers in the Nuclear Fuel and Reactor Industries - Nuclear Safety, May/June (1976).
- (9) Atomgesetz - Bundesgesetzblatt - Bonn, 6/11/1976.
- (10) "News" - Editor: J.S. Carver - Health Physics, 30, 6 (1976).



## AN EVALUATION OF 'RISK' FROM SURVIVAL AND MUTAGENESIS STUDIES

J C Asquith, P D Holt and J A B Gibson  
Environmental and Medical Sciences Division, AERE Harwell, UK.

## 1. INTRODUCTION

The idea that a cancer may be the end product of a series of independently occurring somatic mutations was first suggested by Nordling (1) to explain the relationship between death-rate from all human cancers and the age at which death occurred. Although the somatic mutation theory of carcinogenesis has not been universally accepted, it has been applied by different workers to spontaneous, radiation induced and chemically induced tumours as well as those caused by a combination of radiation and chemical insults. Different groups have suggested different numbers of mutations are required for carcinogenesis. These range from two (2,3) to twelve (4) independent mutations being required in the same cell.

We have used the simplest of these suggestions, the two mutation hypothesis, to generate a theoretical carcinogenesis curve from our experimental data on the survival and mutation of Chinese hamster cells exposed to single doses of  $^{60}\text{Co}$  gamma radiation. The application of the data in this preliminary study to predict tumour induction in the whole animal should enable us to determine those areas which require further investigation.

## 2. EXPERIMENTAL DATA

The survival and mutation experiments were carried out on a V79-4 subline of Chinese hamster fibroblasts. The mutagenesis system we have used is the development of resistance to the purine analogue 6-thioguanine. This resistance is associated with the loss of activity of the enzyme hypoxanthine phosphoribosyl transferase (HPRT).

Our cell line has a continuously bending survival curve following gamma radiation, fitting the equation

$$S = e^{-(\alpha D + \beta D^2)} \quad (1)$$

where S is the fraction of cells surviving, D is the dose in rads and the parameters are  $\alpha = 1.25 \times 10^{-3} \text{ rad}^{-1}$  and  $\beta = 1.5 \times 10^{-6} \text{ rad}^{-2}$  for unsynchronised cells. The induced mutation frequency curve for gamma rays also has components dependent upon the dose and the dose squared:

$$M = (\gamma D + \delta D^2) \quad (2)$$

where M is the probability of mutation induction per cell and the parameters are  $\gamma = 2.9 \times 10^{-6} \text{ rad}^{-1}$ ,  $\delta = 3.45 \times 10^{-11} \text{ rad}^{-2}$

If these results are plotted as log survival versus induced mutation frequency (IMF) the relationship is linear,

$$\ln S = -kM \quad (3)$$

with  $k = 2.3 \times 10^{-5}$

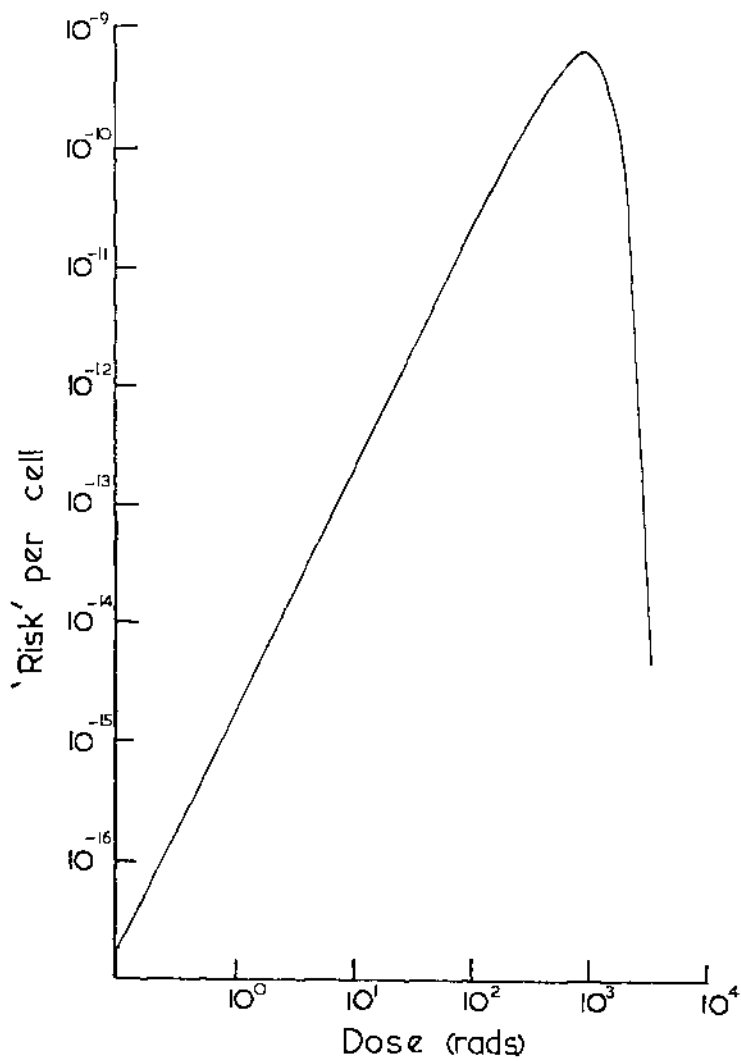

Figure 1 Theoretical carcinogenesis curve (equation 5)

### 3. THEORETICAL CARCINOGENESIS

The probability of two independent mutations occurring in the same cell (P) is the product of the probabilities of either occurring. If we assume that the two critical mutations leading to carcinogenesis have the same induction parameters,  $\gamma$  and  $\delta$ , as the mutation studied, this probability will be

$$P = (\gamma D + \delta D^2)^2 \quad (4)$$

At the same time as causing mutations, the gamma radiation is also killing both mutated and non-mutated cells as described in equation (1). To obtain an estimate of risk of carcinogenesis, that is the probability that a cell will receive both mutations and remain viable, this survival factor must be included:

$$\text{Risk} = e^{-(\alpha D + \beta D^2)} (\gamma^2 D^2 + 2\gamma\delta D^3 + \delta^2 D^4) \quad (5)$$

This equation is plotted in Figure 1 for doses 0.1 to 4000 rad. The increase in risk is dependent on the square of the dose up to 500 rad, after which the curve peaks at  $\sim 900$  rad, then falls away rapidly. Although the risk is shown as dependent upon  $D^2$ , at low doses there is probably a linear component, as there is a statistical probability of both mutations occurring with one traversal of the nucleus. This data is developed from experimental parameters obtained from Chinese hamster cells and is only intended as an example of a risk in dose curve.

One question which this immediately raises is whether this equation is directly applicable to human cells. Preliminary experiments with primary human fibroblasts in our laboratory have not followed equation 1 but have shown a multi target plus single hit survival curve with parameters  $\tilde{n} = 1.5$ ,  $D_0 = 110$  rads. As Thacker and Cox (5) have shown the same relationship between survival and IMF for primary human fibroblasts and Chinese hamster cells, as shown in equation 3, one would anticipate some differences between a theoretical 2-mutation carcinogenesis curve for human fibroblasts and Figure 1.

### 4. COMPARISON WITH RADIATION CARCINOGENESIS STUDIES

This change in the shape of the carcinogenesis curve with the cells used to obtain experimental data makes comparisons difficult, as we would predict that the curve would change, with the survival curve from species to species. This does appear to be the case with radiation carcinogenesis studies. Two reports dealing with skin tumours in rodents serve to illustrate this. Hulse and Mole (2) found that skin tumour incidence in CBA/H mice increased as the square of the dose, with a peak at 4000 rads. Data of Burns and coworkers (6) for rat skin tumours showed a peak at only 2000 rads. This data could not be analysed to show whether the response depended upon the square or some other power of the dose.

A further complication of the situation is that within a given species the radiosensitivities of different cell types can vary quite widely, resulting in a series of carcinogenesis curves for different tissues.

## 5. CONCLUSIONS

A theoretical carcinogenesis curve based on experimental data derived from Chinese hamster cells has been described. This curve shows a typical peaked response, with the maximum at  $\sim 900$  rads.

While it is probable that this curve is not directly applicable to cells from another species, such as man, it is felt that this type of approach may be useful in helping to forge a link between physical and biological studies in radiological protection. For the future we intend to extend this work in several directions. One application is the calculation of risk around a  $\beta$ -emitting particle in lung tissue. We also wish to extend the analysis to high LET radiation induced mutagenesis and other cell types, including primary human fibroblasts. While not intending to work *in vivo* it is important to obtain as much data as possible to prove or disprove the hypothesis presented in this paper.

## REFERENCES

- (1) NORDLING, C.O., A new theory on the cancer-inducing mechanism. *Brit. J. Cancer* 7, 68-71 (1953)
- (2) HULSE, E.V., MOLE, R.H. and PAPWORTH, D.G., Radiosensitivities of cells from which radiation-induced skin tumours are derived. *Int. J. Radiat. Biol.* 14, 437-444 (1968)
- (3) HULSE, E.V. and MOLE, R.H., Skin tumour incidence in CBA mice given fractionated exposures to low energy beta particles. *Brit. J. Cancer* 23, 452-463 (1969)
- (4) BURCH, P.R.J., Radiation and 'natural' carcinogenesis. Does somatic mutation provide a common link? in *Radiation Induced Cancer*, IAEA, STI/PUB/228, Vienna (1969)
- (5) THACKER, J. and COX, R., Mutation induction and inactivation in mammalian cells exposed to ionizing radiation. *Nature* 258, 429-431 (1975)
- (6) BURNS, F.J., ALBERT, R.E., SINCLAIR, I.P. and VANDERLAAN, M., The effect of a 24-hour fractionation interval on the induction of rat skin tumours by electron irradiation. *Radiat. Res.* 62, 478-487 (1975)

A STATISTICAL METHOD FOR DISCRIMINATING BETWEEN ALTERNATIVE  
RADIO BIOLOGICAL MODELS

I. A. Kinsella and J. F. Malone  
College of Technology,  
Kevin Street, Dublin 8, Ireland.

1. INTRODUCTION

Radio biological models are extensively used to aid understanding of the development of radiation damage and as a method of extrapolation of dose-effect curves to low dose regions. Different postulates give rise to different models such as the target theory or DNA strand break models (1, 2) so that it is desirable to have a single procedure for estimating the various model parameters. This procedure should have statistical justification and be applicable to a variety of models. The technique due to Gilbert (3) has been applied only to the Puck and Multitarget models while that due to Chadwick and Leenhouts (2) is applicable only to the quadratic ( $\alpha D + \beta D^2$ ) type model. No attempt has been made by the latter authors to deal with the problem of variance heterogeneity. The approach used here (Section 2) was to use the Maximum Likelihood Method (M.L.M.) for all models in which the observed effect, survival or mutation rate, is a function of dose. An equivalent approach to the Multitarget model is given in (4) and the parameters of the Modified Multitarget are given in (5) The M.L.M. involves finding the parameter set which are most likely with given experimental data. This approach provides a Goodness of Fit test of the given model (Section 3) and a method of discriminating between alternative models (Section 4). Since this paper illustrates the techniques using a single data set no general conclusion is made as to the applicability of any one model in given circumstances.

2. PARAMETER ESTIMATION

The numerical estimates of the parameters of five models, using M.L.M., are given in Table 1. The M.L.M. requires the specification of probability density function (p.d.f.) for the experimental response variable which is assumed Poisson for experiments where the number of surviving cells or clones is measured. The individual models are incorporated into the Poisson p.d.f. by specifying a conditional Poisson p.d.f. with parameter  $\mu c_i p(D_i)$  where  $\mu$  is the zero dose survival and  $c_i$  is the cell concentration exposed to dose  $D_i$ . The five survival curves considered were

- Model 1:  $1 - (1 - \exp(-D/D_0))^n$  ( 1 )
- Model 2:  $\exp(-D/D_1)(1 - (1 - \exp(-D/D_0)))^n$  ( 6 )
- Model 3:  $\exp(-\gamma D/D_1)(1 - (1 - \exp(-(1 - \gamma) D/D_0)))^n$  ( 7 )
- Model 4:  $\exp(-\alpha D - \beta D^2)$  ( 8 )
- Model 5:  $\exp(-\alpha p D - \beta p D^2)$  ( 2 )

Each model was used to set up a Likelihood Function (L.F.) and the numerical values of the parameters which maximize this function were found by the Simplex Search Method (9). The results in Table 1 are from an experiment using Chinese Hamster Ovary Cells (Clone A). The survival criterion was clone forming ability and Table 2 gives the observed and predicted viable clones at each dose for each model.

Model	$\mu$	$D_1$	$D_0$	n	$\gamma$	$\alpha$	$\beta$	p
1	0.77	196.6		1.4				
2	0.75	294.6	543.7	1.7				
3	0.76	203.7	130.8	1.5	0.09			
4	0.58					2.3*	2.3 <sup>+</sup>	
5	0.47					2.1*	5.9 <sup>+</sup>	0.6

TABLE 1 Parameter Estimates for Five Models

\* Scale factor =  $10^{-3}$  + Scale Factor =  $10^{-6}$

Mean Survival

Dose (D)	Actual $\bar{x}_i$	Predicted by Model ( $\hat{\mu}_i$ )				
		1	2	3	4	5
0	78	78	75	77	58	45
196	58	61	62	62	57	56
326	45	51	52	52	56	60
457	65	54	55	54	66	74
587	46	38	39	38	49	56
782	50	54	53	52	63	70
848	65	73	72	71	81	87
979	99	93	89	89	84	84
1110	67	79	73	74	54	49

TABLE 2 Actual and Predicted Clone Survival

### 3. GOODNESS OF FIT TEST

The adequacy of representation of the data by each individual model can be examined using a statistical test devised by Roberts and Coote (10). Their test is an analysis of variance type test which uses the F distribution of the test statistic F as the statistical test criterion

$$\text{Deviation from Model } \sum_i n_i (\bar{x}_i - \hat{\mu}_i)^2 / \mu_i \quad \chi^2 \quad \text{D.F.} \quad \text{M.S.} \quad \text{F}$$

$$d-k \quad \chi^2 / \text{D.F.} = S_1 \quad S_1 / S_2$$

$$\text{Residual Variation } \sum_{i,j} (x_{ij} - \hat{\mu}_i)^2 / \mu_i \quad \sum_i n_i \cdot d \quad \chi^2 / \text{D.F.} = S_2$$

TABLE 3 Goodness of Fit Test  $i = 1, 2, \dots, d$  (doses)  
 $j = 1, 2, \dots, n_i$  (counts/dose)

Here  $\hat{\mu}_i$  is the predicted mean response, and k is the number of estimated parameters in each model. The Deviation  $\chi^2$  reflects the fundamental goodness of fit of the model and the Residual  $\chi^2$  is affected by random variation. The calculated F value will be large when the model is not an adequate fit to the data. Table 4 gives the F values with their associated significance levels and for comparison the mean absolute deviation  $\sum_i |x_{ij} - \hat{\mu}_i| / d$

	Model 1	Model 2	Model 3	Model 4	Model 5
$\chi^2$	2.1 (p>0.05)	2.2 (p>0.05)	3.0 (p>0.05)	4.8 (p<0.01)	14.3 (p<0.001)
$\sum_i  x_{ij} - \hat{\mu}_i  / d$	6.5	6.3	6.3	10.2	15.5

TABLE 4 Results of F test

The data does not show statistically significant deviation from models 1, 2 or 3 which is reflected in low values of the mean absolute deviation while the reverse holds for the remaining two models.

#### 4. COMPARISON BETWEEN MODELS

Cox (11) discusses the problem of discrimination between alternative p.d.f.'s which are postulated as models of data. We use the same approach to get an "index" which can be used for comparisons between models, the index being a function of the numerical value of the log L.F. when the M.L.E.'s are substituted for the unknown parameters. When a model is a good fit to the data the L.F. should be small as the data  $(x_{i,j})$  has a high probability of being observed. We actually calculate a complementary quantity

$$I_k = \sum_{i,j} x_{i,j} \log p_k(D) + \sum_{i,j} x_{i,j} \log L_{i,j} p_k(D)$$

which, for model k, is large when model k is a good fit. The values of  $I_k$  are given in Table 5 and they reflect the conclusion which can be tentatively drawn from Table 3.

Model 1	Model 2	Model 3	Model 4	Model 5
5475.2	5476.2	5476.8	5456.8	5421.0

TABLE 5 Values of  $I_k$  for five models

The broad similarity of models 1, 2 and 3 is again reflected in the similar values of  $I_k$  for these models while the fact that the other two models do not give a good fit to this data is shown up in the smaller value of  $I_k$  for models 4 and 5. It should be borne in mind that this "index" is used here in a qualitative sense as no statistical distribution is being postulated for it.

#### 5. CONCLUSIONS

The statistical methods discussed above are sufficiently robust to meet the demands of a wide range of radio biological models. While the discussion in Section 4 does not allow an absolute value of the probability that one model is better than another be given, it represents an initial step in placing models in order from the point of view of goodness of fit. Further investigations are in progress to determine if more quantitative criterion can be developed for this problem. As only one set of data has been analysed here with reference to five models further work will be necessary with varied data and a wider range of models, before general conclusions on the suitability of one or other model to a particular sort of biological material or radiation type can be specified.

#### ACKNOWLEDGEMENTS

Funds were provided, in part, for this project by the European Atomic Energy Agency (EURATOM) under contract number 148-75-1 BIO EIA

#### REFERENCES

- (1) ELKIND M.M. and WHITMORE C.F., *The Radiobiology of Cultured Mammalian Cells*, (1967), Gordon and Breach, London.
- (2) CHADWICK K. H. and LEENHOUTS H.P., Euratom Report EUR 4918 e.
- (3) GILBERT C. W., *Inst J. Radiat. Biol.*, 16, (1969), 323.
- (4) FROME E. I. and BEAUCHAMP J. J., *Biometrics*, 24, (1968), 595.
- (5) KINSELLA I. A. and MALONE J. F., submitted to *The Statistician*.
- (6) HALL E. J., *Cell Survival after Low Doses of Radiation*, (1975), J. WILEY, 13
- (7) WIDEROE R., *Acta Radiol.*, 10, (1971), 605.
- (8) KELLER A. M. and ROSSI H. H., *Curr. Top. Rad. Res.*, 8, (1974), 85.
- (9) SELDER J. A. and MEAD R., *Comp. J.*, 7, (1965), 308.
- (10) ROBERTS E. A. and COOTE C. G., *Biometrics*, 21, (1965), 600.
- (11) COX D. R., *J.R.S.S. (B)*, 4, (1962), 406.



THE ROLE OF BIOMEMBRANE LIPIDS IN THE MOLECULAR  
MECHANISM OF ION TRANSPORT RADIATION DAMAGE

B.I. Medvedev, Yu.V. Evtodienko, L.S. Yaguzhinsky,  
A.M. Kuzin  
Institute of Biological Physics, Acad. Sci. USSR,  
Pushchino, Moscow Region, 142292, USSR

Study of radiation-induced changes in the content and properties of biomembranes and ion-transporting mechanisms is of great interest. The ion transport systems provide ionic homeostasis thus controlling the mitotic cycle of the cells. These systems are highly radiosensitive. In the recent years experimental studies were also extended concerning damages in membrane permeability and postradiation ionic transport in cell organelles, in particular in mitochondria. Recent studies showed that the ATP synthesis process underlying the energy provision of living systems is directly related to ionic transmembrane movement. In this connection we studied the effect of ionizing radiation on ATP synthesis and  $\text{Ca}^{++}$  active transport coupled to efflux of hydrogen and potassium ions from mitochondria. The rate of ATP synthesis was estimated from the decrease of hydrogen ion concentration in the incubation medium. The values of potassium and hydrogen ionic flows were estimated by ion-selective electrodes. One- and two-dimensional thin-layer chromatography was used to obtain and to analyze the lipid fractions. After addition of calcium ions to mitochondrial suspension hydrogen ions are released due to the action of the hydrogen-pump. After alternate addition of calcium spontaneous equalization of the gradient ions takes place. Here it is possible to measure the maximal value of calcium-hydrogen exchange (calcium-capacity).

When adding calcium ions to mitochondria potassium ions are released as well and we can measure the rate of this efflux. The experimental conditions provided the concentration of endogenous potassium in the mitochondrial matrix to be high ( $10^{-1}\text{M}$ ) as compared to that in the incubation medium ( $10^{-3}\text{M}$ ). Increase in the rate of ATP synthesis (1.4-1.6 times),  $\text{Ca}^{2+}$ -capacity (1.4-1.8 times), membrane potential (by 20-50 mv) and decrease in  $\text{K}^{+}$ -conductivity (2.5-3 times) in rat liver mitochondria was established by a number of experiments three hours after  $\gamma$ -irradiation at a dose of 1000 r. The process of oxidative phosphorylation was normalized 24 hours later, whereas damages of  $\text{Ca}^{2+}$ -accumulation and  $\text{K}^{+}$ -conductivity remain. The circumstance that the experimental mitochondria can accumulate considerably greater amounts of calcium may be essential for regulation of enzymatic processes in the cell since calcium is an important regulatory ion. Moreover in irradiated mitochondria the system providing the potassium efflux from the matrix into the external medium functions at a lower rate on moderate calcium load. A question arises: what is responsible for the decrease of potassium permeability of mitochondrial membranes?

The transport of ions in mitochondria including potassium ions is essentially determined by the properties of the hydrophobic lipid

phase of biomembranes which involves the potassium-transporting system. In this connection it was interesting to investigate permeability of artificial phospholipid membranes (APM) formed from lipids of inner and outer mitochondrial membranes from control and irradiated animals 24 hours after irradiation. In a potassium-free medium the resistance of APM from mitochondrial lipids did not essentially differ for the control and experimental animals and were high. In the presence of potassium ions (100 mM KCl) the resistance of APM from lipids of the control animals dropped one hundred to five hundred times whereas that of the experimental animals kept high.

This points to the fact that in the mitochondrial membrane lipids from the control animals there is a potassium-transporting system whose functioning is successfully reconstructed in artificial membranes. These data enabled the conclusion that the change in mitochondrial membrane permeability is due to substantial changes in the lipids of mitochondrial membranes.

The thin-layer chromatographic analysis of phospholipid composition of the inner and outer mitochondrial membranes from the control and irradiated animals showed a sharp decrease (or absolute absence) of the minor fraction of phospholipids. On the chromatogram this fraction is situated between diphosphatidylglycerol (DPG) and phosphatidylethanolamine (PEA). Introduction of this minor fraction to the APM-mixture of mitochondrial lipids from irradiated animals brought about an increase in  $K^+$ -permeability of APM. Thus it was revealed that this fraction raised the potassium-permeability of APM (potassium-transporting fraction). Upon formation of KCl gradient a membrane potential corresponding to that calculated from the Nernst equation arises on APM. Here the polarity of the potential is negative on the side of the more concentrated solution, which indicates that potassium ions are substantially more penetrating than the chlorine ions. Moreover  $K^+$  ions produced the greatest decrease in electric resistance of APM compared to other monovalent cations:

$$R_K \gg R_{Rb} \gg R_{Cs} \gg R_{Li} \gg R_{Na}$$

Two-dimensional thin-layer chromatographic separation of this fraction and evaluation of the components by the method of APM showed that the fraction consists of several individual compounds with different capability to facilitate the transmembrane movement of potassium ions.

The analysis of the fraction for specific groups: glycol-, carbonyl-, phosphate-, free amino-, choline-, non-terminal N-H gave the positive answer to the phosphate group only. These data as well as the estimation of chromatographic behaviour of this fraction from one- and two-dimensional chromatograms enabled us to conclude that the potassium transporting compounds are lysoforms of polyglycerophospholipids. Chromatographically pure DPG was subjected to mild basic hydrolysis and the hydrolysate was introduced to APM. The potassium permeability of such APM rised sharply.

Special studies of hydrolysis products of DPG and the components of the minor fraction with chemical, instrumental (NMR) and chromatographic methods revealed that one of the endogeneous components of the minor potassium-transporting fraction is lysodiphosphatidylglycerol (LDPG). Introduction of chromatographically pure

LDPG obtained from DPG by chemical modelling resulted in an increase of potassium permeability of APM by two or three orders. The data obtained enable us to believe that lysodiphosphatidylglycerol is one of the endogeneous ionophores of mitochondrial membranes.

Liver mitochondria are known to contain phospholipase A and this enzyme attacks DPC, phosphatidylglycerol, phosphatidic acid and other phospholipids. It is also known that the process of forming of cholesterol esters in liver is coupled to that of lysophospholipids. Cholesterol has been shown to serve as an acceptor for splitted fatty acid molecules. The transfer of fatty acids and acylation of cholesterol is provided also by an enzyme. As irradiation causes inhibition of phospholipase activity, the content of not only lysophospholipids and fatty acids but also cholesterol esters may be expected to decrease. In fact, the analysis supported that after irradiation the content of not only lysopolyglycerophosphatides but also lysoforms of phosphatidylcholine and phosphatidylethanolamine decreases and the content of fatty acids and cholesterol esters in neutral lipids reduces.

The obtained data point to that phospholipases are tightly related to formation of endogeneous ionophores in mitochondrial membranes.

## EFFECT OF GLUTATHIONE ON BIOLOGICAL SYSTEMS IRRADIATED IN VITRO

Roberto Badiello, George Gorin, Marcello Quintiliani, Giustina Simone and  
Maurizio Tamba

Laboratorio di Fotochimica e Radiazioni di Alta Energia (C.N.R.), Bologna (Italy)  
and Chemistry Department Oklahoma State University, Stillwater Oklahoma (U.S.A.)

One of the mechanisms suggested to explain the radioprotective ability of thiol (RSH) either endogenous or hexogenous in living systems postulates the repair of a transient damage to some critical biomolecule (T') by hydrogen donation (1).

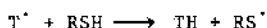

This reaction is supposed to be in competition with that of molecular oxygen at the same site, which, instead, leads to a permanent damage

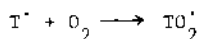

This hypothesis is supported by the observation that, while no oxygen effect is detectable in radiation inactivation, in solution, of biological macromolecules such as DNA and enzymes, this effect appears when thiols are added (2,3). An implication of this hypothesis would be that, in living cells, endogenous sulphhydryls, mostly consisting of glutathione, are involved in the process of natural radioprotection.

The repair reaction by hydrogen donation has been demonstrated by Adams and al (4,5) to occur between cysteamine and a number of simple organic compounds, i.e. alcohols, glucose, synthetic polymers, etc. using the pulse radiolysis technique. No data were reported so far concerning complex biological molecules.

The present communication gives an account of experiments carried out to investigate the mechanism of the radioprotective effect of glutathione in model biological molecules taking into consideration the hypothesis outlined above.

Our results on bacterial survival, on the inactivation of enzymes, such as ribonuclease, yeast alcoholdehydrogenase and aldolase (6); and on structural and chemical changes in DNA and DNA base components, gave further evidence for the radioprotective effects of glutathione in all the systems. We also confirmed that no oxygen effect could be observed in the inactivation of the enzymes, using ribonuclease and yeast alcoholdehydrogenase. Moreover the radiation induced loss of catalytic activity was reduced to the same extent by reduced and oxidized glutathione. This is probably due to the fact that, in dilute aqueous solution, the mechanism of free radical scavenging plays a predominant role.

However, since living matter can be considered as a fairly concentrated solution, the mere radical scavenging mechanism cannot account for the protective effect of relatively small concentrations of glutathione. In any case, our steady state and pulse radiolysis experiments (7) on reduced (GSH)

and oxidized glutathione (GSSG) have shown that both compounds react almost with the same very fast rate with water primary radicals as shown in the Table.

reaction	k (M <sup>-1</sup> sec <sup>-1</sup> )	pH
OH + GSH	1.3 x 10 <sup>10</sup>	5.0
	1.5 x 10 <sup>10</sup>	8.0
	1.7 x 10 <sup>10</sup>	9.2
e <sub>aq</sub> <sup>-</sup> + GSH	6.1 x 10 <sup>9</sup>	7.0
GS <sup>•</sup> + GS <sup>-</sup>	6.6 x 10 <sup>8</sup>	8.0
OH + GSSG	9.9 x 10 <sup>9</sup>	7.0
e <sub>aq</sub> <sup>-</sup> + GSSG	5.0 x 10 <sup>9</sup>	7.0
GS <sup>•</sup> + O <sub>2</sub>	1.6 x 10 <sup>9</sup>	9.2
GSSG <sup>-</sup> + O <sub>2</sub>	1.6 x 10 <sup>8</sup>	9.2

TABLE. Reactivity of radicals with reduced (GSH) and oxidized glutathione(GSSG)

In the table are also shown the rate constants for reaction of reduced and oxidized glutathione with molecular oxygen. These data can be related to the mechanism of gamma radiolysis of reduced glutathione in the presence of oxygen showing a high value of G(-GSH), about 20, which gives evidence of the existence of chain reactions (8). This finding could be of some importance because glutathione, in addition to the competitive mechanism with oxygen postulated above, could also act by reducing the local intracellular concentration of oxygen during irradiation.

Attempts to provide indications for the existence of the repair mechanism by hydrogen donation in biological important molecules were carried out using DNA and DNA base derivatives. Pulse radiolysis experiments of calf thymus DNA in the presence of reduced glutathione have shown a slight influence of glutathione on the decay kinetics of the DNA radical. Such kinetics become significantly faster in the presence of glutathione. However we found considerable difficulties in studying such effects quantitatively. In fact the experiments were limited by the difficulties in handling DNA solutions more concentrated than 0.1% which imposed the necessity of using very low concentration of glutathione, in order to avoid that the scavenging effect of glutathione would become predominant. Glutathione did not show any appreciable influence on the decay kinetics of the thimine radical.

Considering these results, one might observe that, in addition to bases, DNA includes the phosphodiester backbone. As matter of fact, the present biological research indicates that much of the biological important damage, such as single and double strand breaks, actually occurs at the level of the sugar phosphate chain. It cannot be excluded, therefore, that the mechanism of the damage repair by hydrogen donation, could occur at the level of lesions interesting this part of the macromolecules.

#### REFERENCES

- (1) ADAMS G.E., Adv. Radiat. Chem. 3 (1969) 125
- (2) HUTCHINSON F., Radiat. Res. 14 (1961) 721
- (3) JOHANSEN I., HOWARD-FLANDERS P., Radiat. Res. 24 (1965) 184
- (4) ADAMS G.E., McNAUGHTON G.S., MICHAEL B.D., Trans. Farad. Soc. 64 (1968) 902
- (5) ADAMS G.E., ARMSTRONG R.G., CHARLESBY A., MICHAEL B.D., WILLSON R.L., Trans. Farad. Soc. 65 (1969) 732
- (6) QUINTILIANI M., BOCCACCI M., Int. J. Radiat. Biol. 7 (1963) 255
- (7) QUINTILIANI M., BADIELLO R., TAMBA M., GORIN G., Modification of radio-sensitivity of biological systems. LAEA, Vienna (1976), 29
- (8) QUINTILIANI M., ESFANDI A., MATSUI N., GORIN G., Radiat. Res. 35 (1973) 568 (Abs.)

## THE CALCULATION OF LATENT PERIODS

A G Craig

Dept of Pure &amp; Applied Physics

University of Salford, Salford M5 4WI, UK

## 1 INTRODUCTION

This paper presents a calculational model for latent periods corresponding to a biological model of cell progression towards malignancy via a sequence of random step changes in genetic character arising from enhanced faulty DNA synthesis or unbalanced cell division in the abnormal cell; the later stages of cell progression yielding the clinically observed phenomenon of tumor progression (1).

The model assumes that the initiating event, producing abnormal cells by physical, chemical or biological processes, does not significantly determine the latent period and support for this may be found in the time course of malignancies arising from a variety of causes and the apparently successful use of log-normal or logistic models in continuous insult problems (2,3).

## 2 THE MODEL

Assuming a hypothetical 1-D deviant character space, represented by  $x$ , clinical observation of tumour progression suggests that the deviations in cell character should occur via random discrete changes of  $x$  within a continuum of  $x$  values. This contrasts with the more traditional model of 1st order transitions between discrete  $x$  states which does not relate well to experiment.

At some time following the exposure of an assembly of cells to an initiating process there should be a continuous distribution of cells in the  $x$  space. The most useful interpretation of this distribution is, after normalisation, to define  $n(x,t)$ , the probability density function, as the probability of a cell having the value  $x$  at time  $t$ . By analogy with conventional derivations of Fick's law it is readily demonstrated that the probability flux,  $j(x,t)$ , is given by

$$j(x,t) = D(x,t) \frac{d n(x,t)}{dx} \quad (1)$$

The Diffusion coefficient  $D(x,t)$  is regarded as a function of  $x$  &  $t$  because its major factor, mitotic rate, is expected to vary both with age and during tumour progression.

It is readily shown that  $n(x,t)$  is the solution of the generalised diffusion equation

$$\frac{dn(x,t)}{dt} = \frac{d}{dx} \{D(x,t) \frac{dn(x,t)}{dx}\} + S(x,t) - \lambda(x,t) n(x,t) \quad (2)$$

where  $s(x,t)$  represents the production of new cells and  $\lambda(x,t)$  is the probability of losing existing cells.

Defining malignant cells as those with  $x > x_m$  then

$$r(t) = \left. \frac{d}{dt} S(x,t) \right|_{x=x_m}$$

is the probability of a cell becoming malignant at time  $t$ .

Since the production and loss of cells is essentially in balance except in the later stages of tumour growth  $r(t)$  is also the probability of producing a malignant cell at time  $t$  from a cell initially transformed at  $t = 0$  and the cumulative probability of having produced a malignant cell from the original transformed cell is

$$pc(t) = \int_0^t r(t) dt \quad (3)$$

If  $k(D)$  is the probability of transforming a normal cell into the abnormal state for dose  $D$  then the cumulative probability of having produced a malignant cell in an organ with  $N$  target cells is

$$po(t) = Nk(D) pc(t) \quad (4)$$

and the corresponding probability of having produced a tumour is

$$pt(t) = 1 - \exp(-po(t)) \quad (5)$$

which may reduce to

$$pt(t) \approx po(t) = Nk(D) pc(t) \quad (6)$$

### 3 GENERAL DEDUCTIONS & COMMENTS

- (i) probability of tumour occurring depends upon the number of target cells,  $N$ .
- (ii) radiation risk of tumours in various tissues should partially correlate with spontaneous risk of tumours since  $N pc(t)$  (eqn 4) should apply to both cases: eg data by Stewart (4) following pre-natal x-irradiation.
- (iii) Since the diffusion coefficient depends upon mitotic rate there should be an age dependency of latent periods. This is readily confirmed for leukaemia by comparing the Stewart data with adult data.
- (iv) The solution of equation 2 may be written in terms of a Green's Function which is the solution for an instantaneous source (ie equation 2 with  $S(x,t) = 0$ ).
- (v) The Green's function may be obtained directly in practice since it is well described by the latent period distribution function for the high instantaneous dose data available.
- (vi) Extended exposure and continuous insult cases may be obtained by direct time integrals over the Green's function with appropriate magnitude functions. It is readily deduced that the mean latent period correlates inversely with dose rate.
- (vii) the mean latent period for the production of malignant cells is independent of dose magnitude.
- (viii) The mean latent period for tumours may inversely correlate with dose magnitude if eqn. 5 needs to be used (3) but may appear to be independent of dose if eqn. 6 may be used (5).

### 4 A SIMPLE MODEL

In view of the relatively minor differences in mitotic rate between



normal and abnormal tissues the first simplification introduced was

$$D(x,t) = D(x) f(t)$$

$$\& \lambda(x,t) = \lambda(x) f(t)$$

where the function  $f(t)$  essentially describes the age effect. The age correction may now be readily introduced by using  $t' = \int f(t) dt$  and assuming that  $D$  &  $\lambda$  are also independent of  $x$  the model yields

$$n(x,t') = At'^{-0.5} \exp\left(-\frac{\alpha}{t'} - \lambda t'\right)$$

$$\int_{\text{all } x} n(x,t') dx = 1$$

$$r(t') = Bt'^{1.5} \exp\left(-\frac{\alpha}{t'} - \lambda t'\right) \quad (7)$$

$$\text{where } \alpha = \frac{x^2}{4D}$$

The parameter  $B$  in equation 7 can readily be adjusted in numerical work to obtain the correct magnitude of  $r(t')$ . Fits to thyroid data (5) and leukaemia data (6) are shown in figs 1 & 2 respectively with  $t' = t$ . For the thyroid data in fig 1 a crude age correction factor based upon thyroid masses is also included.

## 5 VARIATION OF RISK WITH AGE IN OCCUPATIONAL SITUATION

It has been understood for some time that radiation doses received late in life may carry less risk than those received earlier as natural death may intervene before the malignancy occurs. Using the simple model of the previous section as a convenient analytical form for the real Green's functions the age variation of leukaemia risk relative to age 25 is presented in fig 3 for different assumptions and conditions. Curves A & B in fig 3 show the effect of mortality upon the cancer risk under the assumptions that the sensitivity to radiation induction of tumours is constant with age. Curves C & D allows the sensitivity to tumour induction to vary at the same rate with age as spontaneous leukaemia. These curves indicate that should such an age variation exist it would completely override any reduction in risk from competing mortality processes.

- (1) Roe, F.J.C., Ch 1 of "The Biology of Cancer" (Ambrose, E.J & Roe F.J.C. Eds) Van Nostrand, London (1966)
- (2) Albert, R.E., Altshuler, B. pp 233-253 "Radionuclide Carcinogenesis" (Sanders, C.L., et al., Eds) USAEC (1973)
- (3) Goldman, M., et al., pp 347-357 "Radionuclide Carcinogenesis" (Sanders, C.L., et al., Eds) USAEC (1973)
- (4) Stewart, A.M, quoted in Ch 5 of "Irradiation of the Skeleton" by Vaughan, J.M. Clarendon Press, Oxford (1973)
- (5) Beach, S.A., Dolphin, G.W. Phys. Med. Biol. 6 4 (1962) 583
- (6) Fraumeni, J.F., Jr, Miller, R.W., J. natn. Cancer Instr. 38 (1967) 593

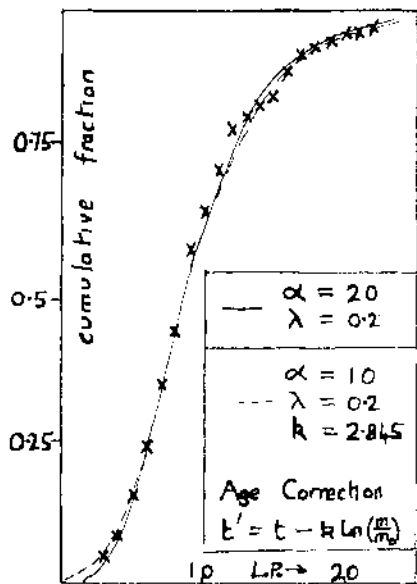

Fig.1. Simple Model Fit to Thyroid data (5)

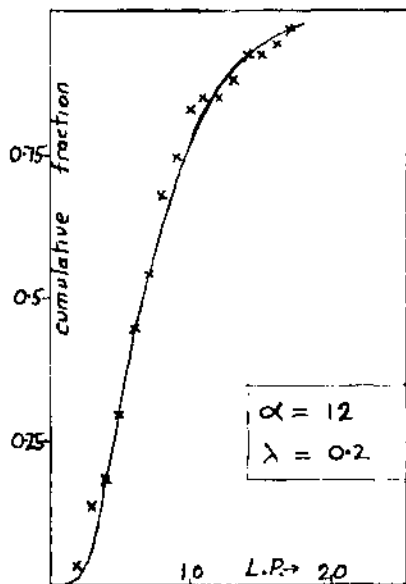

Fig.2. Simple Model Fit to leukaemia data (5)

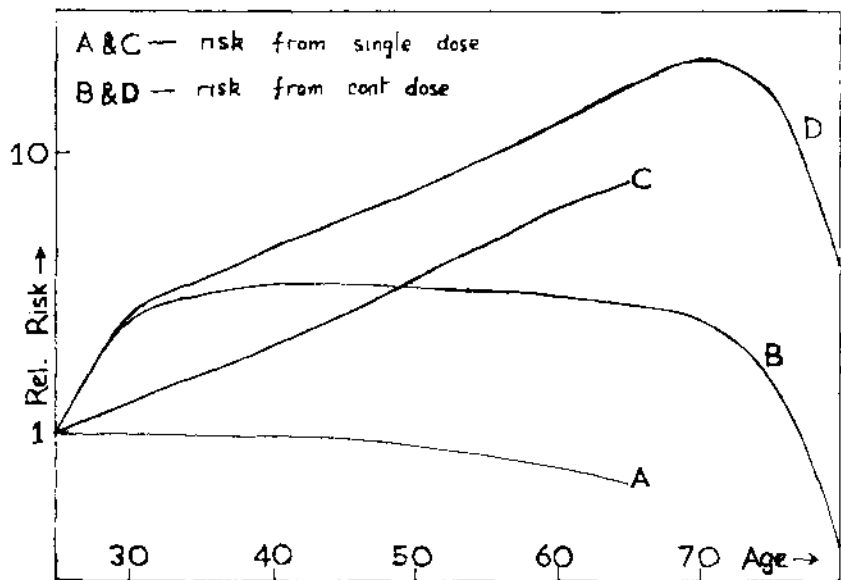

Fig.3. Age Variation of Risk relative to age 25.

SYNERGISM BETWEEN GAMMA AND ULTRASONIC  
IRRADIATION OF THE BACTERIUM E. COLI B

A G Craig and J M R Tyler

Dept of Pure & Applied Physics  
University of Salford, Salford M5 4WT, UK

## 1 INTRODUCTION

Using simple and conventional culture techniques for the bacterium E. Coli B synergism between independently lethal doses of ultrasonic and cobalt-60 gamma irradiation is established by comparing the surviving fraction for gamma irradiations for samples with and without a preceding exposure to ultrasonics.

The results reported here are those of a pilot study where the main aim of the work was to establish whether conditions could be found in which synergism could be demonstrated. As a result of the necessary flexibility of technique for such a project the experimental procedures lack a number of refinements which will be introduced in later work. While this lack of refinement may affect the sensitivity of the tests to determine whether synergism exists as indicated in the text such an effect can clearly not invalidate any positive conclusions reached from these tests.

## 2 EXPERIMENTAL METHOD

Irradiation cultures were produced by 100:1 dilution into 0.85% (w/v) saline of a stationary phase culture, in 'Oxoid' nutrient broth, of the bacterium E. Coli B. This procedure leaves traces of the nutrient media in the samples which could be utilised by the repair mechanism known to operate at room temperatures (1). To avoid complications due to this repair mechanism samples were slowly cooled to around 4°C prior to irradiation and maintained as close to this temperature as possible at all stages of the experiment up to final plating.

Sonication was achieved by lowering the sterilised probe of a 13 kHz ultrasonic cleaning unit into the sample. After a series of trial experiments to investigate the effect of variation of sample size and irradiation geometry upon the reproducibility of readings and the heating effects of sonication the following conditions were selected. The irradiation sample consisted of 80ml of culture in a 100ml beaker which was accurately located at the centre of a 1 litre beaker of crushed ice to limit the heating effect. Despite this precaution a limited temperature excursion did occur during sonication but was limited to a rise of some 10°C after 30 mins exposure and samples returned to the original temperature very rapidly after sonication ceased.

The probe itself was immersed to a depth of 4mm in the culture; a cathetometer being used to ensure accurate relocation. This emphasis on standardised geometry during sonication ensured reasonable reproducibility of dose under conditions where interface reflections were important.

The ultrasonic dose rate was obtained by noting the initial rate of

Ultrasonics		Gamma Exposure Times - (Mins)		
		2	9	19
Exp. (mins)	SF	SF	SF	SF
0	1	0.62 (0.48)	0.078 (-2.47)	0.0072 (-4.94)
4	0.54	0.34 (-0.67)	0.038 (-3.23)	0.0023 (-6.07)
17	0.005	0.39 (-0.47)	0.052 (-2.90)	0.0022 (-6.12)
30	0.014	0.30 (-0.85)	0.021 (-3.82)	0.001 (-6.91)

Table 1. Surviving Fractions for First Series of Experiments (Numbers in brackets are logits used in 't' test).

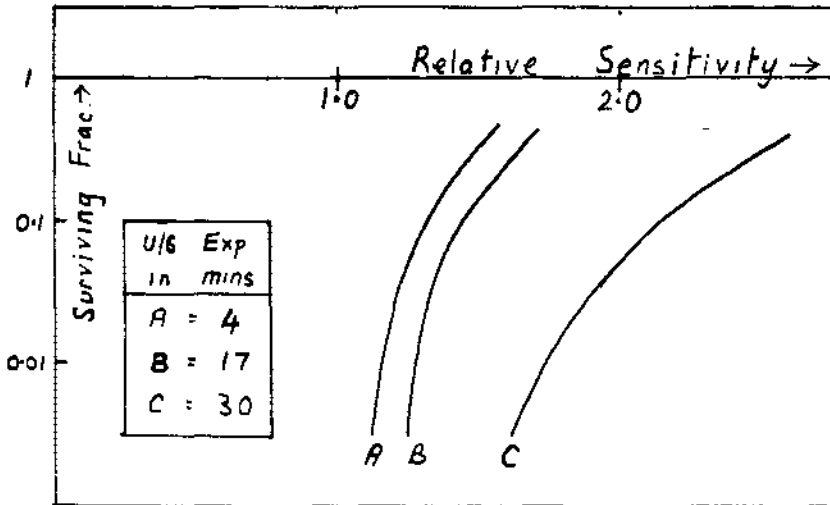

Fig.1 Second Series of Experiments. Relative Sensitivity to gamma irradiation as a function of survival.

increase of temperature of the sample and hence computing the rate of energy deposition as  $64.5 \pm 1.3 \text{ W kg}^{-1}$ .

The gamma irradiation of the samples was achieved by exposure of the 80ml sample in a kilo Curie cobalt-60 facility at a dose rate of  $1.95 \text{ krad min}^{-1}$  as measured by the Fricke method. The sample was contained in a boiling tube which was accurately located in a container of crushed ice at a fixed point in the radiation field. The use of such a large sample permitted small aliquots to be taken without serious perturbation of the irradiation geometry and eliminated the possibility of different samples experiencing different dose rates.

The large sample size clearly involves, however, a considerable variation in dose rate across samples placed close to a large gamma source. Measured plate Counts thus yield the average response to a range of doses but this is not important when comparing samples provided the dose distribution function is the same for both. Although the normal smoothing effect of such an averaging process may result in a reduction of the sensitivity with which synergism can be detected this cannot affect the validity of the conclusions reached below.

A standard time interval of 10 min was allowed between sonication and the subsequent exposure to gamma irradiation. Aliquots taken before and after sonication allow evaluation of the sonic surviving fraction. Aliquots taken after the gamma irradiation allow evaluation of the gamma surviving fraction.

Following appropriate dilution of the aliquots obtained, surface plating on to prepared Petri dishes containing 'Oxoid' nutrient agar and incubation for 24 hours at  $37^\circ\text{C}$  visible colonies were counted and used to calculate the various surviving fractions.

### 3 RESULTS

From trial experiments ultrasonic exposures of 4, 17 and 30 mins were selected to provide a reasonable spread of sonic surviving fractions. These exposure times were used in pre-sonication of samples in both series of experiments.

#### 3.1 First Series of Experiments

From trials gamma ray exposures of 2, 9 and 19 mins were selected.

For each combination of ultrasonic and gamma ray exposures the surviving fraction following gamma irradiation was obtained for samples with and without pre-sonication. These surviving fractions are presented in Table 1.

Since data in the form of proportions does not readily lend itself to standard statistical procedures the surviving fractions were converted into logits using

$$\text{logit, } Q \text{ (SF)} = \ln \left( \frac{\text{SF}}{1-\text{SF}} \right)$$

The Student 't' test as applied to matched pair data was then used to examine the difference in each pair of logits. The 't' value of 8.04 obtained for the nine pairs, and hence eight degrees of freedom, indicates quite clearly that the observed difference in logits, and hence surviving fractions, is most unlikely to have occurred as a

result of random error.

### 3.2 Second Series of Experiments

The differences in surviving fractions discussed in the previous section possibly indicate a dependence upon the magnitude of the ultrasonic and gamma ray exposures. For each value of presonication a gamma ray survival curve over 3 decades was obtained for samples with and without presonication.

Each survival curve was fitted by computer to the simple quadratic formula

$$\ln (SF) = -\alpha D - \beta D^2$$

and the relative sensitivity, (R.S. = dose without sonication to produce given survival divided by the dose with sonication to produce the same survival), obtained for different levels of survival, fig 1.

The curves in fig 1 indicate that the synergistic effect increases with increasing ultrasonic dose. With increasing gamma ray doses for a given presonication the synergistic effect decreases indicating that shouldered survival curves become less shouldered.

### 4 CONCLUSION & COMMENT

Both series of experiments indicate quite clearly that the gamma ray sensitivity increases following presonication. The question is whether this is a genuine synergism or is a result of the heating effect described by Clarke Hill (2) which may be used to explain a number of results for a simultaneous non-lethal sonication and x-irradiation.

Although a temperature excursion did occur during sonication this was eliminated before gamma irradiation commenced and it seems unlikely that the biological 'memory' of such a small excursion could produce such noticeable results. The author's believe, therefore, that these results represent a genuine synergism.

- (1) Stapleton, G.E., et al., J. Cell Comp. Physiol, 41 (1953) 345
- (2) Clarke, P.R., Hill, C.R. Br. J. Radiol. 43 (1970) 97



IV<sup>e</sup> CONGRÈS INTERNATIONAL  
IVth INTERNATIONAL CONGRESS

# **RECUEIL DES COMMUNICATIONS**

VOLUME 2 - Mardi 26 avril  
et mercredi 27 avril

---

# **PROCEEDINGS**

VOLUME 2 - Tuesday April 26th  
and Wednesday April 27th

---

**PARIS 24-30 AVRIL 1977**

## PLUTONIUM IN HUMAN LUNG IN THE HANFORD ENVIRONS

I. C. Nelson and V. W. Thomas, Jr.  
 Battelle, Pacific Northwest Laboratories  
 Richland, Washington USA

## 1. INTRODUCTION

The release or potential for release of radioactive materials to the environs of nuclear facilities has been receiving considerable attention in the press and other news media. Frequently plutonium has been highlighted as a most serious inhalation hazard.

Plutonium has been produced, fabricated, transported, and stored in various forms at the Hanford complex for several decades and has been the subject of substantial research as to its occurrence in the environs.

To assure that programs are adequate, it is necessary to demonstrate the extent to which past and present practices have or have not limited public exposure to plutonium. Both measurements of plutonium in tissue samples from individuals potentially exposed and estimates of exposure based on measured concentrations of plutonium in air as discussed in this paper provide a basis for such demonstration.

## 2. SOURCES OF PLUTONIUM IN AIR

Potential sources of  $^{239}\text{Pu}$  in near-surface air in the Hanford environs have included worldwide fallout from weapons testing and releases of contaminated air from plutonium production facilities and research laboratories and possibly from resuspension of plutonium from along waste ditches, ponds, and burial grounds located at the Hanford complex. The latter potential sources of plutonium may have been of little significance since they would amount to ground-level releases and were located about 32 km from inhabited areas. Since May 1973, waste streams containing plutonium have been routed to tanks for storage, thus eliminating most of that potential for release of plutonium to the Hanford environs (1).

The first thermonuclear device in the weapons testing program was detonated in 1952; however, it was not until 1961-1962 that large amounts of transuranic elements were injected into the atmosphere. An estimated 400 kCi  $^{239,240}\text{Pu}$  were produced during weapons testing, of which about 325 kCi were globally dispersed (2). ( $^{239}\text{Pu}$  and  $^{240}\text{Pu}$  are not distinguishable by alpha spectrometry, and where  $^{239}\text{Pu}$  is cited, the sum of the two nuclides is meant.)

## 3. HANFORD MEASUREMENTS

At Hanford routine measurement of concentrations of  $^{239}\text{Pu}$  in near-surface air began in late 1961 (4); since 1949, autopsy tissue samples have been radioanalyzed for plutonium. The point of near-surface air measurement is within the research laboratory area and about 32 km from the production facilities. Figure 1 shows the measured values beginning in 1962 and expressed as annual average concentrations of plutonium. Values of plutonium in air from 1952 through 1961 were inferred through comparison of  $^{239}\text{Pu}$  and  $^{137}\text{Cs}$  measurements at Hanford and  $^{137}\text{Cs}$  measurements made at Chilton, England (5). Also shown for comparison are concentrations of plutonium in air at New York, N. Y., from 1964 forward and as inferred from 1954 through 1963 based on measurements of  $^{90}\text{Sr}$  deposited on ground and  $^{90}\text{Sr}$  in near surface air (2).



Also shown are annual average concentrations of  $^{239}\text{Pu}$  measured in near-surface air in the USSR for the years 1969 through 1971 (3).

Figure 1 indicates that most of the data agree closely. Except for the year 1964, the measurements of plutonium in surface air at Hanford and New York are within a factor of two or less. The concentration of  $^{239}\text{Pu}$  at Hanford was almost always less than that at New York. Although Hanford plutonium facilities may have contributed to the total, the total concentration of plutonium in air at Hanford appears indistinguishable from fallout-related concentrations measured elsewhere in mid-latitudes in the northern hemisphere.

#### 4. THEORETICALLY ESTABLISHED CONCENTRATIONS OF PLUTONIUM IN LUNG

Expected concentrations of plutonium in lung were calculated using measured concentrations in air, Standard Man parameters, and the ICRP Task Force Lung Model (6,7). Class Y parameters were assumed since the oxide is the expected form of plutonium in fallout. An activity median aerodynamic diameter (AMAD) of  $0.4\ \mu\text{m}$  was assumed to characterize particulate fallout.(8)

Equations for determining the lung burden as a function of time were developed as follows: According to the model, two components remain in the lung, one with a one-day half-time and one with a 500-day half-time. For present purposes, the component with the long half-time predominates in determining the quantity in the lung at a given time. The change in lung burden (referred to as the pulmonary region in the ICRP model),  $Q_p$ , with time may be given by

$$\frac{dQ_p}{dt} = f_e D_1 D_5 - \lambda_p Q_p$$

where  $\lambda_p$  is based on the 500-day half-life,  $f_e = 0.6$  the fraction of the deposited quantity  $D_5$  removed with a 500-day half-time.  $D_5$  is about 0.35 for  $0.4\text{-}\mu\text{m}$  AMAD aerosols.  $D_1$  is the quantity of the inhaled aerosol. Solution of the above equation yields

$$Q_p = \frac{D_1 f_e D_5}{\lambda_p} (1 - e^{-\lambda_p t})$$

which gives the quantity of plutonium in the lung at the end of a period of constant intake. Division of  $Q_p$  by the mass of the lung (1000 g) yields the concentration of plutonium in lung.

Using this equation and the measured and inferred concentrations of plutonium in surface air, the concentration in lung was calculated for individuals who may have resided in the Hanford environs for 1 to 22 years. A breathing rate of  $20\ \text{m}^3/\text{d}$  and a constant level of plutonium in air over one year's time was assumed. The calculated values are tabulated in Table 1. For a given year the total lung burden at the end of the year was determined from the average Pu concentration in air for that year using the above equation plus the total at the end of the previous year decayed for one year with a 500-day half-life. Although exposure begins at birth, adult breathing parameters were used in the calculations.

Figure 2 presents these results graphically for 5-year intervals beginning in 1953. As shown in the figure, concentrations of plutonium to be expected in lung over a 22-year period ranged from about 0.01 to a maximum of 1.1 fCi/g of lung. The average for the period was about 0.4 fCi/g lung. Regardless of the year of initial exposure, the estimated concentration at the end

TABLE 1. Cumulative Concentrations in Lung At End of Period, fCi/g

	1953	1954	1955	1956	1957	1958	1959	1960	1961	1962	1963	1964	1965	1966	1967	1968	1969	1970	1971	1972	1973	1974
1953	0.06	0.10	0.28	0.40	0.50	0.66	1.08	0.76	0.60	0.82	0.82	0.75	0.70	0.50	0.34	0.27	0.22	0.21	0.19	0.16	0.11	0.11
1954		0.07	0.26	0.39	0.50	0.65	1.08	0.76	0.60	0.82	0.82	0.75	0.70	0.50	0.34	0.27	0.22	0.21	0.19	0.16	0.11	0.11
1955			0.22	0.38	0.48	0.64	1.08	0.75	0.60	0.82	0.82	0.75	0.70	0.50	0.34	0.27	0.22	0.21	0.19	0.16	0.11	0.11
1956				0.23	0.40	0.60	1.05	0.73	0.58	0.81	0.81	0.74	0.70	0.50	0.34	0.27	0.22	0.20	0.19	0.16	0.11	0.11
1957					0.26	0.51	1.00	0.70	0.57	0.81	0.81	0.74	0.69	0.50	0.34	0.27	0.22	0.20	0.19	0.16	0.11	0.11
1958						0.35	0.90	0.65	0.53	0.78	0.80	0.74	0.69	0.49	0.34	0.27	0.22	0.20	0.19	0.16	0.11	0.11
1959							0.69	0.52	0.45	0.74	0.77	0.72	0.68	0.49	0.34	0.26	0.22	0.20	0.19	0.16	0.11	0.11
1960								0.10	0.20	0.59	0.68	0.66	0.65	0.47	0.32	0.26	0.22	0.20	0.19	0.16	0.10	0.11
1961									0.14	0.55	0.66	0.65	0.64	0.46	0.32	0.25	0.22	0.20	0.19	0.16	0.10	0.11
1962										0.46	0.60	0.62	0.62	0.45	0.31	0.25	0.21	0.20	0.18	0.15	0.10	0.11
1963											0.32	0.45	0.52	0.39	0.28	0.23	0.20	0.19	0.18	0.15	0.10	0.11
1964												0.24	0.40	0.32	0.23	0.20	0.18	0.18	0.18	0.15	0.10	0.10
1965													0.25	0.22	0.18	0.17	0.16	0.17	0.17	0.14	0.10	0.10
1966														0.08	0.09	0.12	0.13	0.15	0.16	0.14	0.09	0.10
1967															0.04	0.09	0.12	0.14	0.15	0.13	0.09	0.10
1968																0.06	0.10	0.13	0.14	0.13	0.09	0.10
1969																	0.06	0.11	0.13	0.12	0.08	0.10
1970																		0.07	0.11	0.11	0.08	0.09
1971																			0.06	0.08	0.06	0.08
1972																				0.04	0.04	0.07
1973																					0.01	0.05
1974																						0.04

Exposure Beginning

of 1974 ranged from 0.04 to 0.3 fCi/g lung. The total Pu intake by inhalation over the 1953-1974 period is estimated to be 30 pCi. The average lung burden for this period was estimated to be 0.4 pCi. Bennett estimated a 42.6 pCi cumulative intake using the data obtained at New York for the period 1954-1975 (2). An average lung burden of 0.7 pCi was obtained from the New York data.

## 5. TISSUE ANALYSIS

Since 1949, tissue samples obtained at autopsy from residents (non-Hanford workers) in the Hanford environs have been radioanalyzed for plutonium. Figure 3 shows graphically the concentration of plutonium in lung of individuals sampled. One problem associated with these measurements has been the lack of sensitivity commensurate with the very small quantities in the lung. As a consequence, many sample results were reported only as less than the detection limit; this limit has varied over the years and with sample size. In Figure 3, the average ( $\bar{x}$ ) shown is the average assuming each sample result in the set had been as much as the detection limit. Although it too may have been a "less than" value, the maximum reading of the set is also indicated in the figure. The lower value measured in a set of samples is indicated by the letter L.

In 1974, our laboratory converted from an autoradiography measurement technique, which had the advantage of rather good sensitivity but an overriding disadvantage of uncertainty in radiochemical yield, to a process of alpha spectrometry. Improved knowledge of chemical yield through use of  $^{235}\text{Pu}$  and  $^{242}\text{Pu}$  tracers and alpha spectrometry yields more reliable data at a slight loss in sensitivity at reasonable counting times.

## 6. CONCLUSIONS

As shown in Figure 4, the measured and theoretical results compare closely. In most cases, the average concentration of the set was within a factor of 5 of the theoretical estimate. The marked decrease in measured concentrations of plutonium in lung from 1966 to 1970 coincided with an approximate tenfold increase in tissue sample size. That period was also one in which fallout concentrations decreased. Caution should be used in developing conclusions from these results because many of the sample results during this time and earlier were "less thans", and their true value may have been substantially less than that shown. The apparent increase in measured concentrations of plutonium in lung in the period 1971-1974 is not understood. The new alpha spectrometry procedure was used on these samples, and some systematic error in earlier work may be suggested. The possibility of a small contribution from Hanford facilities cannot be absolutely ruled out.

The average concentration in lung over the period covered (assuming a "less than" value to be at detection limit) was 0.5 fCi/g of lung, and the average of the maximum values noted was 0.8 fCi/g. For comparison, the theoretical average value where it is assumed that each year since 1954 an individual is autopsied was 0.4 fCi/g. If Hanford facilities have contributed to the plutonium content of lungs in individuals residing in the environs, that contribution would appear at most to be about that from worldwide fallout. But more likely the plutonium in lung derives almost totally from fallout, and the Hanford contribution is negligible by comparison.

Regardless of source, a sustained lung burden of plutonium of 0.5 fCi/g of lung would relate to a dose of 0.5 mrem/year. Over the 22-year period ending in 1974 a total dose to lung of 10 mrem was estimated from these data.

Numerically, this is trivial compared to the approximately 1600-2000 mrem (1) the individual would likely have received from naturally occurring sources in the Hanford area during this same period.

#### ACKNOWLEDGMENTS

The authors would like to express their appreciation to D. T. Harless for assistance in radiochemical analysis; to T. B. Powers for help with calculations; to C. W. Thomas for assistance in inferring early concentrations of plutonium in air from measurements made of  $^{137}\text{Cs}$ ; and to Dr. P. A. Fuqua, K. R. Heid, and Dr. T. D. Mahony for sample procurement and identification.

#### REFERENCES

1. Final Environmental Statement, Waste Management Operations, Hanford Reservation, Richland, Washington, ERDA-1538, December 1975.
2. Bennett, Burton S., "Transfer of Plutonium from the Environment to Man", in the Proceedings of the International Symposium on the Management of Wastes from the LWR Fuel Cycle, (CONF-76-0701, July 11-16, 1976.
3. Makhonko, K. P., Bobovnikova, Is. I., Volokitin, A. A., and Martynenko, V. P., " $^{238}\text{Pu}$  and  $^{239}\text{Pu}$  Concentrations in the Air Layer Close to Ground in the Podmoskov' E Region in 1969-1971", Translated from Atomnaya Energiya, 38 4 (April 1975), 254-55. Original article submitted August 13, 1974. V0C551 510.72.
4. Thomas, C. W. and Perkins, R. W., Transuranium Elements in the Atmosphere. SNWL-1881, November 1974. Also in ERDA Health and Safety Laboratory Environmental Quarterly, HASL-291, April 1975.
5. Cambray, R. S., Fisher, Miss E.M.R., Eakins, J. D. and Peirson, D. H., "Radioactive Fallout in Air and Rain: Results to the End of 1975", AERE-R 8267, March 1976 (Latest in a series).
6. "ICRP Task Group on Lung Dynamics, Deposition and Retention Models for International Dosimetry of the Human Respiratory Tract", Health Physics 12 (1966), 1973.
7. ICRP, "The Metabolism of Compounds of Plutonium and Other Actinides", ICRP Publication 19 (1972).
8. Shlien, B., Gaeta, N. A. and Friend, A. G., "Determinations of Particle Size Characteristics of Old and Fresh Airborne Fallout by Graded Filtration", Health Physics 12 (1966).
9. Nelson, I. C., Heid, K. R., Fuqua, D. A. and Mahony, T. D., "Plutonium in Autopsy Tissue Samples," Health Physics 22, 1972.

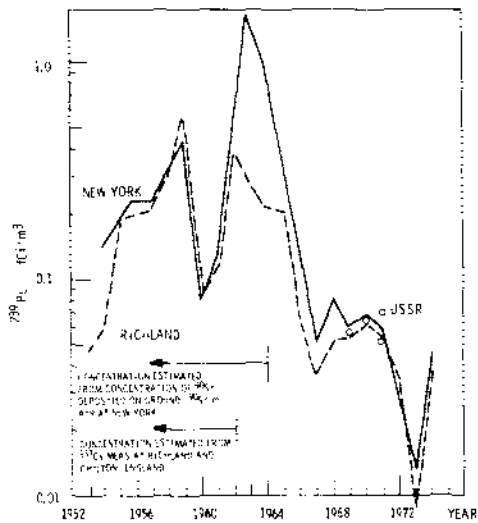

FIGURE 1. Concentration of Plutonium in Surface Air at New York, NY and Richland, WA

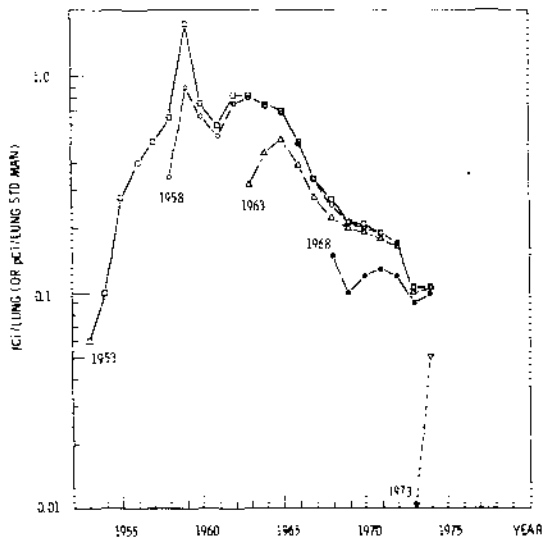

FIGURE 2. Theoretical Concentration of Plutonium in Lung in the Hanford Environs (by year of initial exposure)

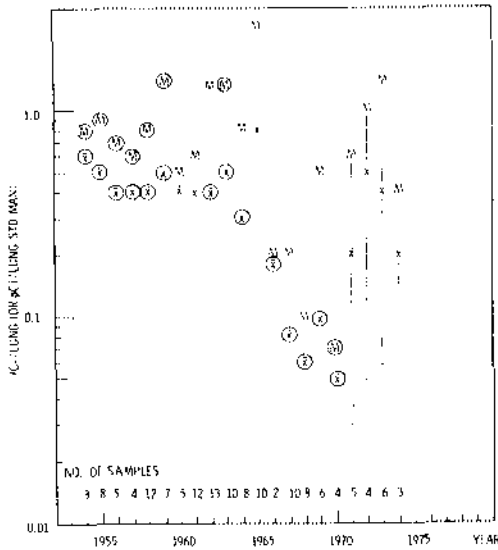

FIGURE 3. Concentrations of Plutonium in Lung

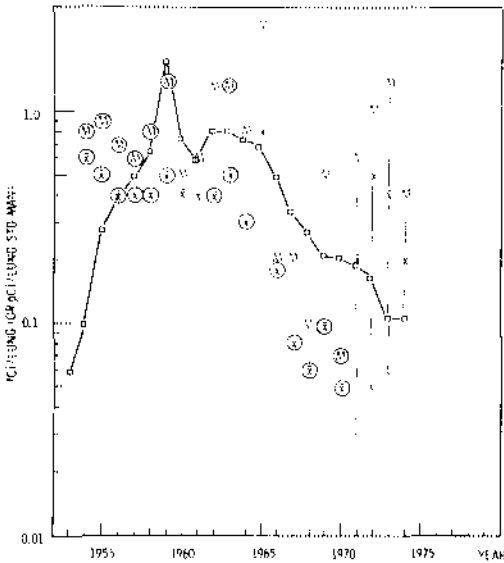

FIGURE 4. Comparison of Measured and Theoretical Concentrations of Plutonium in Human Lung

## EVALUATION OF THE HAZARD TO RESIDENTS OF AREAS CONTAMINATED WITH PLUTONIUM

Carl J. Johnson

Jefferson County Health Department and the University of Colorado School of Medicine  
Lakewood, Colorado 80226INTRODUCTION

Plutonium oxide particles deposited on the ground surface by accidental spills or atmospheric fallout (Table 1) are subject to resuspension by wind or other means. Particles in the size range of 5  $\mu\text{m}$  and smaller are considered to be of respirable size because when inhaled they may be retained within the lung<sup>(1)</sup>. Most of the plutonium oxide particles released offsite by nuclear installations are in this size range<sup>(2)</sup>. This paper describes a method of measuring the concentration of plutonium in the potentially respirable surface dust and discusses the potential health effects of exposure to such dust.

SAMPLE COLLECTION AND PROCESSING

In our study area (downwind from the Rocky Flats plant) sites for sampling were selected following guidelines proposed by the Atomic Energy Commission<sup>(3)</sup>. A composite sample of the loose, surficial (about 0-0.5 cm deep) soil material was collected with a clean brush and a clean plastic container within an area of 4 m<sup>2</sup> when the ground surface was dry<sup>(4)</sup>. Plutonium oxide particles likely exist in association with other soil particles as micro-aggregates and, therefore, behave as such. Microaggregates of soil are dynamic and are affected by freezing and thawing, wetting and drying, the kind and amount of natural cementing agents present, and by other forces that tend to disrupt or reconstitute them<sup>(5)</sup>. These plutonium-oxide-microaggregate associations cannot be measured except by methods that tend to alter their natural state. In contrast, our procedure seeks to maximize the dispersion of the microaggregates to expose the plutonium oxide particles and to evaluate the maximum potential hazard. Attention to the dispersion of microaggregates will tend to alleviate the problem of the effect of microaggregation on the precision of the data and will provide data that are comparable from season to season or from site to site.

About 50 g of soil material that passed a 2-mm screen was treated by standard methods with hydrogen peroxide to remove organic material. The sample was then washed and filtered to remove soluble salts, and was mechanically dispersed with a 300 watt ultrasonic probe for 15 minutes. Sodium metaphosphate was added when necessary to facilitate dispersion of the particles.

Particles of respirable size were separated by size and density with a standard water-sedimentation technique<sup>(6)</sup>. The threshold settling velocity was computed from Stoke's equation using an effective diameter of 5  $\mu\text{m}$  and a density of 11.36 g/cm<sup>3</sup> (plutonium oxide). The size fraction thus collected includes other mineral particles with equivalent settling velocities that have same combination of smaller density and larger diameter. The collected fraction was freeze-dried and analyzed for plutonium by radiochemical procedures<sup>(7,8)</sup>. Contamination of offsite soils in the study area (an area proposed for residential development) was found to be as great as 380 times the background value. We believe that the concentration of plutonium in the respirable fraction of surface dust, as defined here, is an index that can be more readily related to the potential health hazard than other indices utilized for this purpose.

PARTICLE SIZE AND ACTIVITY

Relationships between particle size, volume, mass and radioactivity are shown in Table 2. A particle of plutonium oxide one  $\mu\text{m}$  in diameter weighs about six millionths of a microgram ( $\mu\text{g}$ ). This particle is very small but has an activity of 0.3 picocuries (pCi) or about one disintegration every 1.5 minutes. A particle 5  $\mu\text{m}$  in size has a mass of

.0007 $\mu$ g. This particle is also of respirable size and will have an activity of about 41 pCi or some 90 disintegrations per minute (dpm). One hundred of the 5  $\mu$ m particles together would weigh about 0.07  $\mu$ g. Since plutonium has a biological activity 15 or more times as great as radium, this many particles of plutonium oxide may be similar in effect to 0.5  $\mu$ g of radium, the smallest bone dose found associated with osteosarcoma in radium dial painters<sup>(9)</sup>. Although plutonium may be present in contaminated areas offsite in extremely small quantities, this may be sufficient to produce bone cancer and other types of tumors.

#### ESTIMATES OF DOSAGE AND EFFECT

The recommended dose limit of plutonium 239 (occupational exposure) to lung is at present 15 rem/year or 16,000 pCi. This maximum permissible annual dose (MPAD) is equivalent to about 400 five  $\mu$ m particles, or a total mass of about 0.3  $\mu$ g of plutonium oxide. A single particle of plutonium oxide 40  $\mu$ m in size has more than this much activity and is within the range of atmospheric dust (0.3 to 100  $\mu$ m). A particle of this size might not be retained in the respiratory tract, but could lodge in an abrasion or other wound.

Meyers gives evidence to support a recommendation that a much more realistic limit than the present 15 rem MPAD for lung burden is the "maximum permissible pulmonary lymph node burden" which is placed at 230 pCi<sup>(10)</sup>. The maximum lung level that could produce this is 67 pCi. Meyers points out that this is less than 0.5% of the currently accepted MPAD (occupational) of 15 rems for the lung. The inhalation and retention of two 5  $\mu$ m particles annually would exceed this amount. Morgan also demonstrates that the present limit for exposure to plutonium may be too high by a factor of 240 or more, in relation to potential effects on bone<sup>(11)</sup>. Again, two of the 5  $\mu$ m particles would exceed this more conservative dose limit.

The relative risk of inhaling and retaining plutonium oxide particles in reference to the amount of plutonium in the respirable dust is illustrated in Table 3. A single 4  $\mu$ m particle may produce about 50 dpm, equivalent to about 20 millirems. One such particle in 25 grams of respirable dust will produce an average activity of 2 dpm/gram of dust. If a person has inhaled and retained 12.5 grams of dust, he has a 50% chance of inhaling that 4  $\mu$ m particle of plutonium oxide. However, the particle may be in the first bit of dust inhaled or in the last bit. The probability is one in 100, expressed in the table as  $p=.01$ , that if he inhales only 1/4 gram, that he may inhale the 5  $\mu$ m particle. Retention of two of these particles, or an equivalent larger number of smaller particles, would exceed dose limits proposed by Morgan and Meyers. It may be that in the very first whiff of dust (25 milligrams) that he may inhale the particle. The chances are about one in one thousand that this could occur. In a total population of 100,000 or more who could be housed in a contaminated area such as that near the Rocky Flats plant, these odds seem significant.

The effects on populations of exposure to low levels of radiation have been studied by the Advisory Committee on the Biological Effects of Radiation of the National Academy of Sciences and the National Research Council<sup>(12)</sup>. The committee discusses the Federal Radiation Council's maximum permissible level of 5 rem over 30 years (170 mrem/year). This dosage, 170 mrem, is equivalent to about four of the five  $\mu$ m plutonium oxide particles, or to about 20 grams of respirable dust with 20 dpm/g of plutonium. The committee thinks that this level would likely result in an increase of cancer deaths by about 2%. In addition, they calculate that the effect of 170 mrem/year would cause in the first generation an increased incidence of 0.05% of serious, dominant, or x-linked diseases and defects per year. This is one birth in 2,000. However, after several generations, these numbers would be five times larger, that is, there would be one birth in 400 with defects and serious dominant, or x-linked diseases per year. In



addition the committee states that when the congenital abnormalities and constitutional diseases which are partly genetic are added to this, the total incidence would be one case per thousand births in the first generation, and about one case in 133 births for succeeding generations. The committee also believes that between 5% and 50% of ill health is proportional to the mutation rate. This much radiation per generation could eventually lead to an increase of 5% in the ill health of the population.

Estimates of excess rates of cancer may also be calculated in the following manner, again referring to an area with 20 dpm/g of plutonium in respirable dust. This example is a calculation of the increased rate of bone cancer in such a contaminated area.

$$\frac{10^6 \text{ person-rem}^{(13)}}{10 \text{ excess bone cancer cases}} \cdot \frac{1000 \text{ pCi(inhaled)}^{(14)}}{3.2 \text{ rem (bone)}} \cdot \frac{2.2 \text{ dpm} \cdot 1 \text{ g}}{1 \text{ pCi} \cdot 20 \text{ dpm}} = \frac{3.4 \text{ g dust}}{1 \text{ excess bone cancer}/10^6 \text{ persons}}$$

Offsite lands in our study area (downwind from the Rocky Flats plant) have levels far in excess of this amount, and a development project five kilometers east of the plant site has levels that approach 20 dpm/g in respirable dust. We see that about 3.4 grams of such dust (32 pCi), inhaled and retained, may result in one excess bone cancer in a population of one million people over a life span. Other effects from this dosage of radiation may be calculated in a similar manner. Such effects would be multiplied for each additional 3-4 grams of respirable dust inhaled\*. Over a period of months or years a person may inhale and retain 10 to 12 grams or more of resuspended dust (100 pCi) and may receive about 0.1 rem to the lung, 4-5 rem to the trachio-bronchial lymph nodes, and 0.12 rem to the liver. The gonadal and fetal dose is difficult to evaluate, but plutonium has been found in gonadal tissue and in the fetus. This amount of exposure to one million people could result in about 160 excess deaths due to leukemia and a total increase in all neoplasms of perhaps 1 to 3 per cent over a period of 70 years<sup>(12)</sup>. This may include from 6 to 1000 excess cases of bone cancer (this large range is due to two points of view)<sup>(11, 12)</sup>. The incidence of all genetic diseases may increase by 1.5% and ill health related to chromosome mutation by 10%, for all succeeding generations<sup>(12)</sup>. Other factors, such as the ingrowth of Americium, use of chelating agents in fertilizers, etc. may change the nature of the risk and actually increase the incidence of effects. Because plutonium is stored in the body to a considerable extent, a person living several years in such an area may inhale and retain enough plutonium to produce these effects even though he may leave the area. Effects are more likely to occur in the fetus, the child, and in persons with increased susceptibility to neoplasms. There is evidence that smaller doses of radiation are more harmful per rad than would be expected. Stewart and Neal and others have shown a greater risk of leukemia per rad at low intrauterine exposures, 0.25-0.5 rad, than at higher doses to the fetus<sup>(15)</sup>. One rem (equivalent to 25  $\mu\text{m}$  particles) may cause an 80% increase in mortality from childhood cancers after fetal exposure, and a 0.9% increase in recognized "spontaneous" abortions<sup>(13)</sup>.

## CONCLUSION

Federal guidelines are being promulgated by the U.S. Environmental Protection Agency to guide the use, treatment, and rehabilitation of land contaminated with plutonium. At the present time there are areas in the United States which have levels of contamination of 19 dpm/g in respirable dust which are presently being used or developed for residential purposes<sup>(16)</sup>. The importance of the establishment of a maximum allowable level of contamination based on the concentration of plutonium in the respirable dust must be emphasized. This level may be appropriately set as low as 2 dpm/g, since there is sufficient evidence to indicate probable health effects at the 20 dpm/g level and possibly at levels below this figure.

REFERENCES

- Anderson, D.C.: Chronic non-neoplastic respiratory disease. In Cline, D.W., and MacMahon, B. (Eds.) *Preventive Medicine*. J. & A. Churchill Ltd., London, 1967.
- Eider, J.C., Gnepp, M., and Ellinger, H.J.: Plutonium aerosol characterization. *Health Physics*, 27: 45-53, 1974.
- Measurements of radionuclide levels in the environment, sampling and analysis of plutonium in soil. Standards for protection against radiations. U.S. Energy Res. Dev. Adm. Regulatory Guide 4.5, 10 CFR, part 20, Federal Register 20, no. 126, 1975.
- Johnson, C.J., Tibbitts, R.R., and Severson, R.C.: Plutonium hazard in respirable dust on the surface of soil. *Science*, 193: 488-490, 1976.
- Kunze, G.W.: Pretreatment for geochemical analysis. In Black, C.A., and others, ed., *Methods of soil analysis*, part 1: Madison, Wis., Amer. Soc. Agronomy, 243-577, 1965.
- Dey, P.R.: Particle fractionation and particle size analysis. In Black, C.A., and others, ed., *Methods of soil analysis*, part 1: Madison, Wis., Amer. Soc. Agronomy, 1965.
- Telvitte, N.A.: Radiochemical determination of plutonium in environmental and biological samples by ion exchange. *Anal. Chem.*, 40: 1827-1830, 1968.
- \_\_\_\_\_: Electrodeposition of actinides for alpha spectrometric determination. *Anal. Chem.*, 44: 260-263, 1972.
- Martland, L.S., and Hingorani, S.L.: Oxygen's sorption in clay minerals using uniform particles. *Arch. Pathol.*, 7: 456, 1929.
- Meyers, D.S.: A plan for long-term long-term criteria for isolation of the spent fuel isotopes. U. of Calif., Lawrence Livermore Lab., Health Physics, June, 1979.
- Morgan, K.Z.: Suggested reduction of permissible exposure to plutonium and other transuranium elements. *Am. Ind. Hyg. Ass. J.*, 567-574, August, 1975.
- ANRS: The effects on populations of exposure to low levels of ionizing radiation. Report of the Advisory Committee on the Biological Effects of Ionizing Radiation, Division of Nuclear Sciences, National Academy of Sciences. National Research Council, Washington, D.C., 1970a, November, 1972.
- ANRS: Approaches to population protection in the case of nuclear accidents. (Nuclear) Office of Radiation Programs, U.S. Environmental Protection Agency, Washington, D.C., 1970b.
- Thompson, R.C.: Ion behavior with respect to the Fractionation and other Transuranium Elements Sources, environmental distribution and biological effects. Public Report WASH-1779, U.S. Atomic Energy Commission, December, 1974.
- Stewart, A., Webb, J., and Roberts, D.: A survey of childhood malignancies. *British Med. J.*, 1: 1455, 1958.
- Johnson, C.J.: Survey of land proposed for residential development east of Rocky Flats, for a uranium-235 concentration of respirable dust on the surface of the soil, and proposal of a new standard to define the potential plutonium-plutonium particle hazard in terms of concentration of plutonium in respirable dust. Report to the Jefferson County Commissioners and the Colorado State Health Department. *Univ. Colo.*, September 9, 1975.
- Wrenn, M.E.: Environmental levels of radionuclides and the transuranium elements in plutonium and other transuranium elements sources, environmental distribution and biological effects. WASH-1779, U.S. Atomic Energy Commission, December, 1974. (Testimony before an Environmental Protection Agency hearing, June, Washington, D.C.).
- Bennett, B.G.: Environmental pathways of transuranium elements. WASH-1729 (1974).

\* As much as 67 mg/m dust per cubic meter (mg/m<sup>3</sup>) has been measured downwind from some equipment. An average value of 0.135 mg/m<sup>3</sup> was measured in Denver in 1976-77. An average concentration of 0.001 to 0.020 mg/m<sup>3</sup> for plutonium.

Acknowledgements: Valuable assistance of R.R. Tibbitts, S.D. and R.C. Severson, Field of the U.S. Geological Survey in the design and execution of the survey, and the rest of the report.

Table 1  
Concentrations of Plutonium in Soil

Location	Disintegration per minute gram
Worldwide (average)	0.0 to 0.1
Central New Mexico (Triityte)	0.3 to 22.2
Nevada Test Site*	0.2 to 22.2
Los Alamos Subterranean Laboratory*	0.01 to 11
Rocky Flats*	0.4 to 21
St. Vrain Atoll	2.9 to 422
Polonares	0 to 296
Enfitelex Atoll	76 to 714

\*CPIA file  
Adapted from Ref. 17

Table 2  
Fractionation of plutonium particles in 10 micrometers (d<sub>p</sub>) mass in air, as a function of particle activity in solution (239 Pu) in comparison with the activity of plutonium particles (total) by particle (239 Pu) and plutonium particles.

Particle size (µm)	Volume (cc)	Mass (µg)	Activity (pCi)	Activity (dpm)
40	31,510	0.75	21,000	42,000
5	6	0.75	41	90
4	11	3.8	21	46
2	4.7	4.5	7	15
1	0.5	5.0	0.3	0.7

Table 3

Activity of a dust-inhalation source and secondary activity per unit for plutonium

Table 4

Dose equivalent in rem per 100 probabilities of plutonium-239 inhalation

Activity of plutonium in respirable dust	Assuming one particle, gram dust inhaled per day	Relative risk of inhaling and retaining plutonium particles, by level of activity of respirable dust and quantity of dust inhaled daily (rad)	Relative risk of inhaling and retaining plutonium particles, by level of activity of respirable dust and quantity of dust inhaled daily (rad)	Relative risk of inhaling and retaining plutonium particles, by level of activity of respirable dust and quantity of dust inhaled daily (rad)	Relative risk of inhaling and retaining plutonium particles, by level of activity of respirable dust and quantity of dust inhaled daily (rad)
2 dpm/g	12.5	0.26	0.25	16,110	247
5 dpm/g	5	0.10	0.01	70	70
10 dpm/g	2.5	0.05	0.01	36,200,000	10
20 dpm/g	1.2	0.02	0.01	Mass	20

\* 50 times the level of activity of 2 dpm/g dust inhaled per day (assuming one particle, gram dust inhaled per day) is assumed for the purpose of this calculation. The relative risk of inhaling and retaining plutonium particles, by level of activity of respirable dust and quantity of dust inhaled daily (rad) is assumed to be 1.0 for the purpose of this calculation.

DIFFUSION DU PLUTONIUM EN MILIEU MARIN  
 ETUDE QUANTITATIVE EFFECTUEE SUR DES ESPECES MARINES  
 DU LITTORAL DE LA MANCHE  
 DE BREST (Pointe St Mathieu) A HONFLEUR \*

A. FRAIZIER et J.C. GUARY  
 Commissariat à l'Energie Atomique  
 Laboratoire de Radioécologie Marine  
 B.P. 270 - 50107 CHERBOURG, France

## 1. INTRODUCTION

Nous avons, dans cette étude réalisée en 1975-1976, mesuré la radioactivité due au plutonium chez diverses espèces marines recueillies dans un secteur situé de part et d'autre de l'usine de retraitement des combustibles irradiés de La Hague (Brest/Pointe St Mathieu - Honfleur) (Fig. 1).

Nos résultats sont susceptibles d'apporter des compléments d'information sur la diffusion du plutonium en mer, depuis un émissaire de rejets d'effluents radioactifs : en effet, à l'exception de travaux concernant le compartement du plutonium dans l'environnement marin proche de l'usine de retraitement des combustibles irradiés de Windscale (Grande-Bretagne), la plupart des recherches font plutôt état du devenir du plutonium issu des retombées atmosphériques, dans le milieu marin.

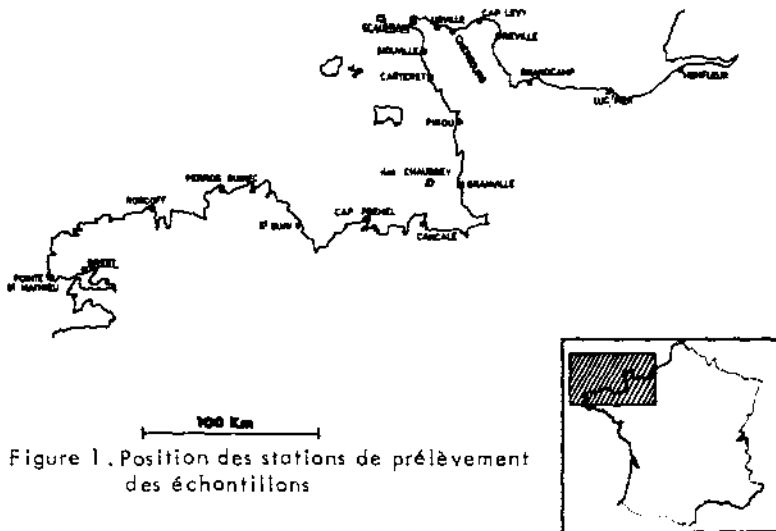

## 2. MATERIEL ET METHODES

Les espèces indicatrices suivantes ont été sélectionnées en fonction de leur pouvoir d'accumulation du plutonium et de leur disponibilité (1) : un lichen :

\* Le texte intégral de cette communication sera publié sous forme de rapport CEA : CEA-R-4822 (1977).

Lichina pygmaea (F.C.<sup>1</sup> ~ 4290), deux algues : Corallina officinalis (F.C. ~ 1175) et Fucus serratus (F.C. ~ 423), un spongiaire : Hymeniacidon sanguinea (F.C. ~ 1495) et un crustacé cirripède : Balanus balanoides (F.C. ~ 503).

Les emplacements des sites de prélèvement sont indiqués Fig. 1, la station d'Ecalgrain a été choisie en raison de sa proximité de l'émissaire de l'usine de retraitement des combustibles irradiés de La Hague.

Le traitement des échantillons pour la mesure du plutonium fixé a été effectué suivant des méthodes précédemment décrites (2).

### 3. RESULTATS

On trouvera tableau 1 les radioactivités en plutonium (isotopes 238 - 239 et 240) des échantillons prélevés dans les différentes stations. L'évolution des niveaux de radioactivité en fonction de la position des stations de prélèvement le long du littoral est sensiblement identique pour L. pygmaea, F. serratus, C. officinalis et H. sanguinea ; par contre la teneur en plutonium de B. balanoides montre, par rapport aux précédentes, une variation moindre dans l'espace.

Stations de prélèvement	Espèces					
	<u>L. pygmaea</u>		<u>C. officinalis</u>	<u>F. serratus</u>	<u>H. sanguinea</u>	<u>B. balanoides</u>
	1975	1976		1975		
Brest (Pointe St Mathieu)		3,5 ± 0,4				
Rocoff		3,3 ± 0,4				
Parro Guirec		9,5 ± 1,2				
St Quay Patrieux		32,8 ± 4,1				
Cap Frehel		37,4 ± 4,7				
Canaele			7,8 ± 0,9	3,1 ± 0,3	5,6 ± 0,7	8,4 ± 1,0
Granville	23,5 ± 2,9	43,1 ± 5,4	8,9 ± 1,1		4,2 ± 0,5	4 ± 0,5
Plou				3,9 ± 0,4		10,2 ± 1,2
Cartaret	73,7 ± 9,2	49,1 ± 6,1				8 ± 1,0
Stauville	333 ± 41,6	132,7 ± 16,5	40,1 ± 5,0		26,8 ± 3,3	13,6 ± 1,7
Ecalgrain (La Hague)	174,8 ± 21,8	190,8 ± 23,8	69,4 ± 8,6	23,4 ± 2,9	36,6 ± 4,5	17,3 ± 2,1
Urville			80,6 ± 10,0		28,5 ± 3,5	16,8 ± 2,1
Cap Levy	123,7 ± 15,4	76,1 ± 9,5	27,4 ± 3,4			
Réville			29,1 ± 3,6	19,2 ± 2,4	9,2 ± 1,1	
Grandcamp			20,1 ± 2,5			5,9 ± 0,7
Luc sur mer			5,1 ± 0,6	7,1 ± 0,8	8,5 ± 1,0	5,2 ± 0,6
Hanfleur				2,1 ± 0,2		4,1 ± 0,5

TABLEAU 1 - Radioactivité du plutonium fixé par les différentes espèces (pCi/kg frais d'échantillon)

La radioactivité des espèces marquant un maximum au niveau d'Ecalgrain, il convenait de comparer les radioactivités des échantillons des diverses stations à celles mesurées pour ce site particulier. Attribuant à ces dernières une valeur arbitraire égale à 100 nous avons calculé, par rapport à celles-ci, et pour chaque espèce, une valeur relative correspondante exprimée en pourcentage. L'ensemble des pourcentages obtenus pour L. pygmaea, F. serratus, C. officinalis et H. sanguinea (B. balanoides devant être considéré comme un cas particulier) a permis le tracé d'une courbe globale d'évolution de la radioactivité en plutonium, de part et d'autre du point de rejet (Fig. 2).

### 4. DISCUSSION

Les observations selon lesquelles la radioactivité due au plutonium fixé par les cinq espèces choisies diminuait en fonction de la distance entre le point

<sup>1</sup> F.C. (Facteur de concentration) =  $\frac{\text{Radioactivité spécifique de l'espèce (pCi/kg frais)}}{\text{Radioactivité spécifique de l'eau de mer (pCi/l)}}$

de rejet de l'usine de La Hague et la point de prélèvement vont dans le sens de celles faites dans le secteur de Windscale. D'après les données de Mitchell (3) (4) (5), le facteur de réduction de la radioactivité de l'algue Porphyra en fonction de la distance du point de rejet de l'usine de Windscale, serait, pour un éloignement de 40 km, de l'ordre de 1,5 à 2,3 - valeurs comparables à celles que nous avons observées à des distances analogues.

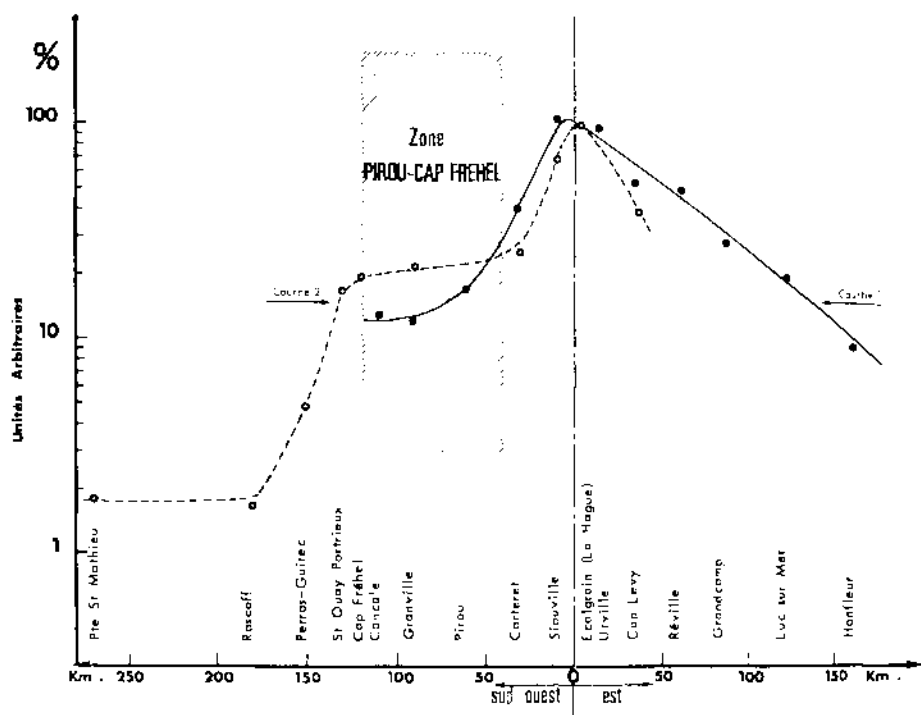

Figure 2. Evolution relative de la radioactivité en plutonium des espèces de part et d'autre de la zone de référence Ecalgrain.

- Courbe 1 : pour l'ensemble des échantillons prélevés en 1975 (à l'exception de *B. balanoides*)
- Courbe 2 : pour *L. pygmaea* prélevé en 1976.

Le facteur de réduction pour les stations situées à 100 km est de 5 à 10 par rapport à la zone proche de l'émissaire. A cette distance les niveaux de radioactivité due au plutonium étaient, dans la plupart des cas, encore supérieurs à ceux attribuables aux retombées atmosphériques en milieu océanique et mesurés chez diverses espèces marines : 1,8 pCi/kg frais pour le spongiaire Clathria delicata (Cap Cod - Océan Atlantique, 1970), 0,34 pCi/kg frais pour l'algue rouge Chondrus crispus et 0,57 - 1,36 pCi/kg frais pour l'algue brune Ascophyllum nodosum (Plymouth Harbor - Océan Atlantique, 1971) (6), 0,58 - 0,76 pCi/kg frais pour l'algue brune Laminaria saccharina (ouest de Point Loma - Océan Pacifique, 1973) (7), 5,4 pCi/kg frais pour l'algue brune Fucus vesiculosus (Golfe de Finlande - Mer Baltique, 1974) (8). Au delà de 150 km les niveaux de radioactivité des espèces mesurées tendent à se rapprocher de ces dernières valeurs.

Il apparaît que le plutonium présent dans les effluents liquides de l'usine de La Hague qui subissent une dilution très importante à la sortie de l'émissaire ( $10^6-10^7$ ) (9), peut cependant être détecté dans le milieu marin même à distance ; des constatations analogues ont été faites pour les produits de fission (10).

En ce qui concerne la dissymétrie dans l'évaluation du taux de radioactivité des espèces de part et d'autre de la zone de rejet (Fig.2), on peut admettre que celle-ci est en rapport avec le sens général de déplacement de l'effluent dans l'aire marine proche (nord - nord-ouest, puis nord-est) (11). Des mesures effectuées *in situ* en février-mars 1975 (12) ont montré une décroissance régulière de la teneur en plutonium de l'eau de mer depuis une station située au nord du cap de La Hague jusqu'à une station proche des côtes danoises de la mer du Nord, cette teneur variant de  $10,6$  à  $0,4.10^{-3}$  pCi/kg. Les auteurs considèrent que ce phénomène est consécutif aux rejets de l'usine. L'examen de la figure 2 montre cependant que les niveaux de radioactivité due au plutonium ne décroissent pas d'une façon régulière en fonction de la distance pour la partie sud et ouest de la zone étudiée, ce qui pourrait correspondre à de moins bonnes conditions d'élimination du radionucléide liées à l'hydrodynamique, aux conditions de sédimentation et à la topographie de cette enclave du littoral. Ceci est à rapprocher des observations faites pour les sédiments en différents points du golfe normanno-breton (13).

Enfin, nous avons constaté que la radioactivité en plutonium de *B. balanoides* n'évoluait pas, en fonction de la distance, suivant une loi identique à celle des autres espèces. Il faut noter que ce crustacé représente, parmi les organismes choisis, l'échelon phylogénétique le plus élevé : des mécanismes biologiques plus évolués pourraient le rendre apte à opérer une certaine discrimination entre les différentes formes physico-chimiques du plutonium, distribuées dans l'espace, à partir de l'émissaire.

## 5. CONCLUSION

Les résultats de nos mesures du plutonium en milieu marin montrent que l'influence des rejets de l'usine de La Hague peut se faire sentir à distance. Il est apparu que la distribution du radioélément dans la zone concernée s'opérerait de part et d'autre de l'émissaire de rejet, toutefois sa diminution, en fonction de l'éloignement, présente en direction du sud et de l'ouest (golfe normanno-breton) une certaine discontinuité.

### REFERENCES

- (1) GUARY, J.C., FRAZIER, A., Observations *in situ*, sur les mécanismes de transfert du plutonium en milieu marin, Note CEA-N-1820 (1975).
- (2) FRAZIER, A., GUARY, J.C., Recherche d'indicateurs biologiques appropriés au contrôle de la contamination du littoral par le plutonium, in : "Transurium nuclides in the environment", I.A.E.A., Vienne (1975) 679.
- (3) MITCHELL, N.F., Radioactivity in surface and coastal waters of the British Isles, Technical Report FRL 7 (1968).
- (4) MITCHELL, N.F., Radioactivity in surface and coastal waters of the British Isles, Technical Report FRL 8 (1970).
- (5) MITCHELL, N.F., Radioactivity in surface and coastal waters of the British Isles, Technical Report FRL 9 (1971).
- (6) NOSHKIN, V.E., et al., Plutonium in North Atlantic ocean organisms - ecological relationships, in : "Proc. 3rd Symp. Radioecology", Oak-Ridge, Vol. 1 (1971) 681.
- (7) HODGE, V.F., et al., Rapid accumulation of plutonium and polonium on giant brown algae, *Health Phys.* 27 1 (1974) 29.
- (8) MIETTINEN, J.K., et al., Plutonium isotopes in aquatic food chains in the Baltic Sea, in : "Impacts of releases from nuclear facilities into aquatic environments", I.A.E.A., Vienne (1975) 147.
- (9) LAFICQUE, G., Etude de l'environnement marin d'une usine atomique et du comportement des traceurs radioactifs (circulation, diffusion, dispersion, sédimentation). Essai de méthodologie de spectrométrie gamma et statistiques des ensembles utilisés, Note CEA-N-1245 (1974).
- (10) SCHEIDPAUER, J., Programme de surveillance de l'environnement marin du Centre de La Hague, in : "Population dose evaluation and standards for Man and his environment", I.A.E.A., Vienne (1974) 347.
- (11) AUSSET, R., Rejets en mer des eaux résiduaires faiblement radioactives du Centre de La Hague, *La Houille Blanche* 4 (1969) 381.
- (12) MURRAY, C.N., KAUSKY, M., Plutonium and americium values in the North Sea and German coastal region, *Surface and Coastal Marine Sciences* (in press).
- (13) GILQUENIAT, P., et al., Note sur l'évaluation de la radioactivité cristalline dans les sédiments de la Manche pendant les années 1971-1975, Rapport CEA-R-4739 (1976).

MEASUREMENT OF ACTINIDES IN SAMPLES  
FROM EFFLUENT AIR, PRIMARY COOLANT AND EFFLUENT WATER OF  
NUCLEAR POWER STATIONS IN THE FEDERAL REPUBLIC OF GERMANY

R. Winkler, H. Hötzl, G. Rosner

Gesellschaft für Strahlen- und Umweltforschung mbH München  
Institut für Strahlenschutz  
D-8042 Neuherberg, Federal Republic of Germany

## 1. INTRODUCTION

As is well known, actinides have entered the human environment as a consequence of nuclear weapon testing, accidental releases and effluent discharges from nuclear processing facilities (1). Until now, little attention has been paid to the release of actinides from nuclear power reactors under normal operating conditions. This is mainly due to the extremely low activity concentrations to be expected and to the well known difficulties arising in the analysis of alpha-particle-emitting nuclides in samples with low specific activity.

In order to establish the contribution of actinides from reactor effluents to the radiation dose of the public living in the vicinity of nuclear power stations, a study on levels of transuranium nuclides in emissions of nuclear power reactors in the FRG was started in 1975 in cooperation with the Bundesgesundheitsamt (Federal Health Office). Based on the experience in low-level alpha-particle spectrometry and on plutonium fallout measurements since 1970, procedures for the analysis of actinides in effluents have been worked out. On the one hand, these procedures should have high sensitivities to observe releases as low as possible - in the case of airborne effluent from the stack a detection limit of  $4 \cdot 10^{-14}$  Ci/m<sup>3</sup> for alpha-particle emitting nuclides is required (2) - on the other hand, the methods must be practicable for routine analysis. On that account, methods requiring only simple and as few as possible chemical steps were preferred to complicated chemical separation procedures.

## 2. PROCEDURES

Essentially, the following procedures of sample preparation for direct alpha-particle spectrometry in large-area gridded ionization chambers were used: (a) low-temperature ashing of the aerosol filter samples in "excited" oxygen, (b) coprecipitation of the alpha-particle-emitting nuclides from effluent water samples with iron hydroxide and subsequent low-temperature ashing of the precipitate together with the filterpaper, and (c) evaporation of the samples from the primary cycle on stainless steel dishes.

The principle of the ashing procedure used is the removal of organic matter by excited oxygen at low temperatures. The treatment is accomplished in a chamber operating at a few mbar pressure of oxygen plasma, which is formed by coupling radio-frequency to the gas through electrodes properly situated remote

from the samples to be treated (3). In most cases, samples are obtained ready for direct alpha-particle spectrometry. Thus, time-consuming additional chemical steps, incomplete recovery and the need of tracers for yield determination are avoided. More experimental details are given elsewhere (4).

## 2.1 Effluent Air

Aerosol filters of the normal installed stack monitoring systems of the nuclear power reactors were used. In routine operation filters were changed weekly by the reactor staff. Depending on the reactor station different sizes and materials of the filters were used and other sampling conditions varied as well. Air flow rate was about 200 to 1000 m<sup>3</sup> per week. Mainly three types of filters were used: (a) asbestos, (b) glass and (c) cellulose fiber filters. Asbestos and glass fiber filters of 50 mm diameter were put into aluminum dishes and organic material of the deposited aerosols was removed in a low-temperature asher (Mod. 1003, Internat. Plasma Corp.). Cellulose filters of 100 mm diameter were cut in pieces before ashing. Organic material of the aerosol deposit, as well as the cellulose was ashed and the hardly visible residue adhered well to the aluminum dishes.

## 2.2 Effluent Water

Water samples from any water released from the discharge tank are stored and mixed, proportionally to the volume released, to give monthly samples. Sampling is done by the reactor operators. Up to 500 ml of the monthly samples is poured from the plastic storage bottle into a beaker and 2 mg of iron(III)-carrier in 1 ml 2N hydrochloric acid is added. During stirring, the solution is heated to nearly the boiling point and concentrated ammonium hydroxide solution is added dropwise until iron hydroxide is precipitated completely. After 1 hr the precipitate is filtered onto a 6 cm diameter filter (No.589<sup>1</sup>, Schleicher und Schüll) on a Büchner funnel. Precipitate and filter are transferred into an aluminum dish and dried. After ashing in the low-temperature asher a finely dispersed brown residue remains on the aluminum surface.

## 2.3 Primary Coolant

In a plastic bottle, 1 liter is sampled weekly by the reactor staff. Because of the low salt content, it is possible to obtain sources suitable for alpha-particle spectrometry by evaporation of 200 ml in portions in a stainless steel dish of 60 mm diameter.

## 2.4 Measurement

Because of the advantages in measuring large samples with low specific activity, gridded ionization chambers were used for alpha-particle spectrometry. Sample dishes up to 200 mm diameter can be introduced in these chambers (Mod. NIK, GSF and Mod. AIK 300, Münchener Apparatebau). Counting time was 80000 sec in most cases and minimum detectable activity for e.g. Pu-239 is 0,03 pCi, based on three times the standard deviation of the background.



### 3. RESULTS

Effluent air filters continuously sampled or single samples from 1973 to 1976 from five nuclear power plants, effluent water from all nuclear power reactors in the FRG from 1973 and 1974, and samples of primary coolant from one power plant from 1974 and 1975 were investigated.

In all samples from the primary coolant and in a number of effluent air samples all or some of the following actinides have been identified: Pu-239/240, Pu-238 and/or Am-241, Cm-242 and Cm-244. In some cases also uranium (U-234, U-238) was found. The activity level of the waste water samples was in the order of the detection limit of the procedure in most cases and these nuclides only in a few cases have been identified. In moderately fresh samples Cm-242 showed the highest activity level of all observed nuclides.

Detection limits of the procedures depend on the sample volume, but generally these limits were in the order of 0.1 fCi per m<sup>3</sup> of effluent air and of 0.2 pCi per liter of effluent water, respectively. Spectrometric resolution normally was 40 to 200 keV FWHM. The lines of Pu-239 and Pu-240 and of Pu-238 and Am-241 will not be resolved.

As an example, in Fig.1 the alpha-particle spectrum of aerosol filter samples from the stack monitoring system of a boiling water reactor is shown. In this spectrum all above mentioned nuclides have been identified. In Fig.2 a typical alpha-particle spectrum of the primary coolant from another reactor but also of the BWR-type is presented. Primary coolant is supposed to be the main source of activity released from a reactor.

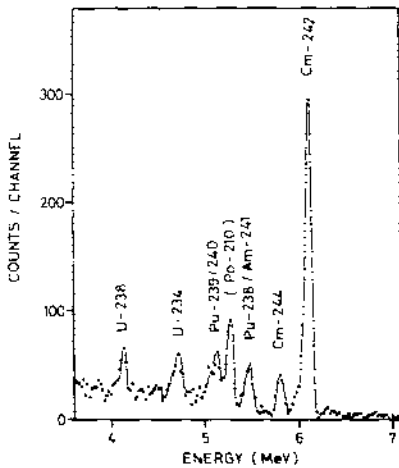

Fig.1: Alpha-Particle Spectrum of an Effluent Air Sample

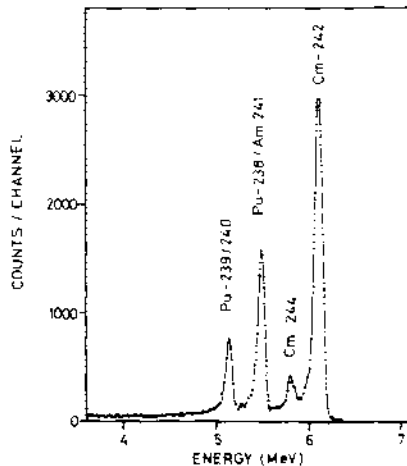

Fig.2: Alpha-Particle Spectrum of a Primary Coolant Sample

The ranges of activity levels (lowest and highest values which were ever determined during the investigations) found in the different sample types and reactors (4) are summarized in Tab.1. In the case of airborne effluent and liquid effluent samples much values are close to the detection limits of the procedures.

Sample Type	Sample Activity in pCi			
	Pu-239/240	Pu-238/Am-241	Cm-242	Cm-244
Effluent Air	<0.1 - 1.3	<0.07- 0.9	<0.04- 8.3	<0.05-6.2
Effluent Water	<0.1 - 2.9	<0.1 - 2.6	<0.1 - 4.6	<0.1
Primary Coolant	0.03-18.9	0.03-36.0	0.03-96.2	0.03-6.0

Table 1: Ranges of Single Actinide Activities in Samples of Effluent Air, Effluent Water and Primary Coolant

It should be noted, however, that until sampling is examined in detail to be representative, no emission rates should be calculated from the above given figures.

To give an idea of the sensitivity of the procedures in terms of emission rates, with respect to a detection limit of 0.1 fCi/m<sup>3</sup> of effluent air and of 0.2 pCi/l of effluent water one can calculate minimum detectable emission rates of 0.2  $\mu$ Ci/a per actinide with airborne effluent (air flow rate  $2 \cdot 10^9$  m<sup>3</sup>/a) and of 2  $\mu$ Ci/a with liquid effluent (annual waste water volume  $10^4$  m<sup>3</sup>). As a consequence of an emission rate of 1  $\mu$ Ci/a Pu-239 the annual activity intake by inhalation for a person living in the vicinity of a power reactor has been estimated at about five orders of magnitudes lower than the maximum permissible annual intake given in the new German Radiation Protection Ordinance (5). In the case of intake by ingestion of drinking water the corresponding factor is about  $10^{-9}$ . Investigations on the application of the above procedures for environmental monitoring of actinides are in progress.

The financial support of the Bundesminister des Innern is gratefully acknowledged.

#### REFERENCES

- (1) Transuranium Nuclides in the Environment, Proc. of a Symposium, San Francisco, Nov. 17-21, 1975, STI/PUB/410, IAEA, Vienna (1976)
- (2) Richtlinie zur Überwachung der Abgabe radioaktiver Stoffe mit der Kaminabluft von Kraftwerken mit leichtwassergekühltem Reaktor (Stand: Sept. 1975), Umwelt 44 (1975) 20-22
- (3) GLEIT, C.E., HOLLAND, W.D., Analyt. Chem. 34 (1962) 1454-1457
- (4) HÖTZL, H., ROSNER, G., WINKLER, R., Untersuchungen über den Nachweis von Alphastrahlern in Proben aus dem Abwasser, dem Primärkreislauf und der Abluft von Kernkraftwerken der BRD aus den Jahren 1973-1975, GSF-Bericht GSF-S-412, Neuherberg, Mai 1976
- (5) Verordnung über den Schutz vor Schäden durch ionisierende Strahlen (Strahlenschutzverordnung - StrSchV) vom 13. Okt. 1976, Bundesgesetzblatt Nr. 125 (1976) 2905-2995

LE RUTHENIUM  
CAS PARTICULIER DU DEVENIR D'UN RADIONUCLEIDE  
DANS LE MILIEU MARIN

P. GUEGUENIAT - R. GANDON  
Commissariat à l'Energie Atomique  
Laboratoire de Radioécologie Marine  
B.P. 270 - 50107 CHERBOURG, France

Le comportement du ruthénium 106 dans le milieu marin - objet de ce travail - a été déjà largement étudié par de nombreux auteurs. Nous revenons sur cette question car l'apparition de nouvelles formes physico-chimiques dans les effluents rejetés en mer, par l'usine de traitement de combustibles irradiés de La Hague, d'une part remet en question les méthodes de dosage dans l'eau de mer et d'autre part amène à réviser certaines données en ce qui concerne le devenir de ce radionucléide dans le milieu.

- Description sommaire des formes physico-chimiques du ruthénium 106 dans l'eau de mer

C'est par l'intermédiaire des usines de traitement de combustibles irradiés que le principal radioisotope de fission du ruthénium, de nombre de masse 106, se trouve introduit dans le milieu marin. Dans les effluents de ces usines le ruthénium prend la forme de composés du nitrosyl-ruthénium n'ayant pas d'équivalent sur le plan physico-chimique avec le radioruthénium  $^{103}\text{Ru} - ^{106}\text{Ru}$  des retombées et avec le ruthénium stable présent dans l'eau de mer. Les composés du nitrosyl-ruthénium sont caractérisés par l'existence d'un groupement  $\text{RuNO}$  très stable dans lequel le ruthénium possède la coordinence 6 ; selon la nature des ligands on distingue : les composés nitrate du type  $\text{RuNO}(\text{NO}_3)_x$ ,  $(\text{OH})_y$ ,  $(\text{H}_2\text{O})_z$  et les composés nitro caractérisés par rapport aux précédents par l'existence d'un ou plusieurs groupements  $\text{NO}_2$ .

Dans l'eau de mer il se produit un réarrangement de la structure des complexes selon deux réactions concurrentes: hydrolyse et formation de dérivés chlorés solubles. Il en résulte l'apparition de nombreuses formes que l'on peut regrouper en trois grandes catégories : A B C.

- Forme A : elle groupe un ensemble de composés colloïdaux, cationiques et éventuellement neutres ou même anioniques possédant des propriétés d'adsorption élevées.

- Forme B : ce sont des formes anioniques non adsorbables directement mais reliées aux précédentes par des réactions d'équilibre. Les composés B seront par conséquent amenés à être adsorbés, après disparition de l'eau de mer des composés A, selon la constante de vitesse des réactions  $\text{B} \rightarrow \text{A}$ .

- Forme C : elle représente une forme anionique stable.

Pour expliquer le fractionnement et préciser les propriétés des formes A B C il convient d'examiner les courbes des figures 1 et 2 qui représentent respectivement la fixation de composés nitro sur du bioxyde de manganèse et celle de composés nitro et nitrate sur un même sédiment :

- Les formes A B C, la transformation  $\text{B} \rightarrow \text{A}$ , apparaissent figure 1

- Les composés nitrato sont moins stables que les composés nitro ; par rapport à ces derniers ils présentent un pourcentage supérieur en forme A et inférieur en forme C ainsi qu'une vitesse de réaction  $B \rightarrow A$  plus rapide. Au sujet de cette dernière les résultats reportés figure 2 montrent, pour l'exemple choisi, qu'il faut attendre 200 jours pour les composés nitrato, plusieurs années environ pour les composés nitro pour provoquer une transformation totale de  $B \rightarrow A$  après disparition initiale de A.

- Les proportions respectives des formes A B C dépendent non seulement de la nature de l'adsorbat mais également de l'adsorbant. Dans le cas des trois types d'adsorbant suivants : sédiments grossiers et fins, bioxyde de manganèse, et pour un même adsorbat, on peut proposer le schéma suivant :

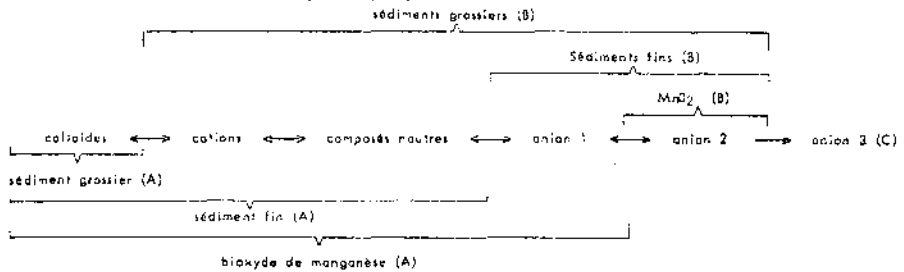

- Quelle que soit le pourcentage des formes A et B, lorsque A disparaît de la solution la quantité de B redonnant A dans un intervalle de temps compris entre  $t_1$  et  $t_2$  est proportionnelle à  $\log(t_2 - t_1)$  et correspond à une loi d'adsorption tout à fait inhabituelle. Cette loi se traduit par des courbes de fixation du ruthénium B sur  $MnO_2$  et sur sédiments fins (fig. 1 et 2) linéaires lorsque l'on adopte une représentation graphique semi-lagarithmique.

Ces conditions générales étant passées, il convient d'examiner le cas des effluents de l'usine de La Hague, mélange de composés nitro et nitrato du nitrosyl-ruthénium mal connus. Par suite de modifications apportées dans le traitement des combustibles à l'usine, d'améliorations dans les traitements avant rejet, on peut estimer dans l'ensemble que la forme physico-chimique du ruthénium - entre les premiers rejets effectués en 1967 et ceux effectués actuellement - a évolué de composés nitrato vers des composés nitro. Les résultats de fixation du ruthénium d'effluents 1967 et d'effluents actuels sur un même sédiment, reportés figure 3 et comparés à ceux reportés figure 2 témoignent de cette évolution.

Ces résultats nous ont amenés d'une part à réviser la technique classique de dosage dans l'eau de mer par adsorption sur  $MnO_2$  car cette méthode n'est efficace que dans la mesure où le  $^{106}Ru$  se trouve essentiellement sous forme nitrato ( $A=80 - 100\%$ ) et d'autre part à comparer les facteurs de transfert des formes A et B au niveau de certaines espèces d'algues.

#### - Dosage du ruthénium dans l'eau de mer

Nous avons en opérant par double précipitation sur  $MnO_2$  dosé A et B séparément :

a) une première précipitation de 15 grammes de  $MnO_2$  sous forme colloïdale permet d'extraire les formes A présentes dans 1 000 litres d'eau de mer (volume raisonnable pour une bonne détection) en maintenant un temps de contact précipité-solution de 24 heures.

b) sur l'eau déjà épuisée en formes A par le traitement précédent une seconde.

précipitation permet d'adsorber les formes B en maintenant un temps de contact d'un mois (voir figure 1).

c) la forme C non adsorbée par  $MnO_2$  même après le second traitement a été décelée expérimentalement à partir d'extraits récents d'effluents. Il faut souligner que l'on ne sait pas encore doser cette forme in situ.

L'application de cette technique dans les eaux littorales du cap de La Hague (zone de référence), à proximité de l'émissaire de rejets, a montré entre septembre 1974 et juillet 1976 une évolution très sensible dans les propriétés physico-chimiques du ruthénium rejeté :

Septembre 1974 - Janvier 1975	-	forme A
Mai 1975	: A : 87,5 %	B : 12,5 %
Juin 1975	: A : 70 %	B : 30 %
Novembre 1975	: A : 50 %	B : 50 %
Février 1976	: A : 48 %	B : 52 %
Juillet 1976	: A : 57 %	B : 43 %

Les teneurs des eaux filtrées ( $0,4 \mu$ ) en forme A, exprimées en valeur moyenne (pCi/litre) chaque demi-mois, reportées figure 4 montrent que la valeur maximale observée a été de l'ordre de 25 pCi/litre en décembre 1974 (B - nan décelable).

#### - incidence des paramètres physico-chimiques sur les taux de fixation du $^{106}Ru$ par diverses espèces d'algues

L'évolution constatée ci-dessus dans les propriétés du ruthénium  $^{106}$  des effluents est théoriquement favorable puisque ceux-ci comportent des proportions croissantes en formes anioniques difficilement hydrolysables en principe peu contaminantes (B). L'analyse des phénomènes observés in situ montre, contrairement à l'hypothèse précédente, généralement admise, que ces dernières formes rejetées peuvent être directement fixées par certaines algues à des taux supérieurs aux formes cationiques et hydrolysées. Les évolutions des teneurs en formes facilement adsorbables dans l'eau de mer (A) et celles du  $^{106}Ru$  dans diverses espèces d'algues relevées dans la zone de référence, pendant une période d'observation de septembre 1974 à juin 1976, reportées figures 4 et 5 ne présentent en effet pas de corrélation pour Chondrus, Porphyra et surtout Enteromorpha. Les facteurs de concentration les plus importants (teneur en  $^{106}Ru$  dans l'espèce/teneur A + B dans l'eau de mer) pour ces algues sont observés dans le cas de faibles teneurs en A et une forte proportion en B dans l'eau de mer.

## CONCLUSION

Les modifications dans le traitement des combustibles irradiés, l'amélioration dans les techniques de décontamination des effluents de l'usine de La Hague avant leur évacuation dans le milieu ont entraîné un changement dans les propriétés physico-chimiques du ruthénium. On constate en effet l'apparition en proportion notable de formes stables anioniques peu hydrolysables et non fixées par le bioxyde de manganèse jusqu'ici employé pour la détection du  $^{106}Ru$  à partir de grands volumes d'eau. La technique de dosage par double précipitation sur bioxyde de manganèse a permis d'améliorer la détection et d'apporter de nouvelles informations sur la répartition in situ des différentes formes physico-chimiques du ruthénium. Ainsi, il semble, contrairement aux hypothèses jusqu'à présent avancées, que certaines formes anioniques seraient fixées sur diverses espèces d'algues directement sans hydrolyse préalable à des taux

relativement importants et supérieurs à ceux des formes cationiques et facilement hydrolysables. Ces observations amènent à réviser certaines données acquises en ce qui concerne le transfert du ruthénium dans le milieu marin.

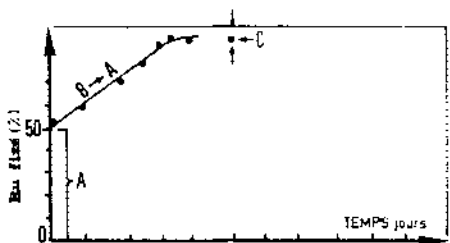

Fig. 3 Fixation (%) des complexes nitro sur  $TiO_2$  (50 mg/litre)

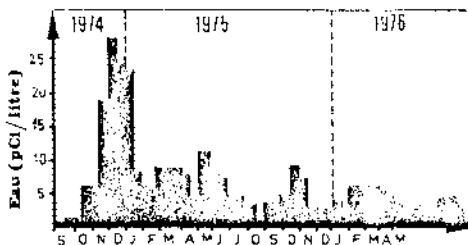

Fig. 4 Teneur des eaux en forme A ( $^{106}Ru + ^{106}Rh$ ) après filtration.

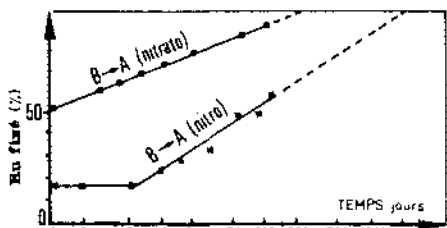

Fig. a Fixation des complexes nitro (—●—) et nitrate (—○—) par un même sédiment (2 grammes sédiment/200 cm<sup>3</sup> eau de mer).

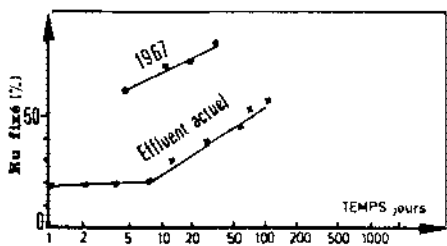
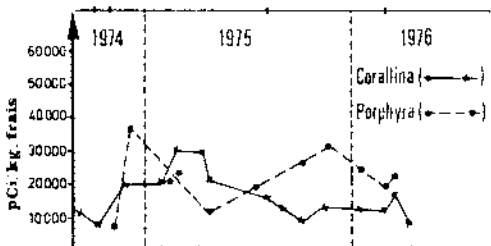

Fig. b Fixation (%) du ruthénium d'un effluent 1967 et d'un effluent actuel sur un même sédiment fixe.

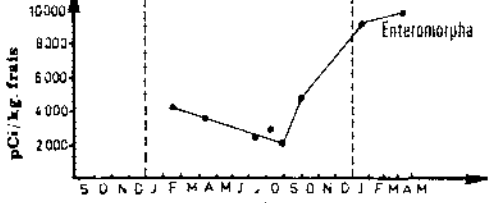
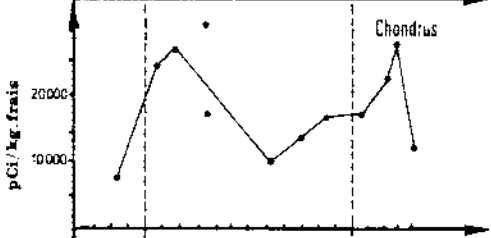

Fig. 5 Teneur du  $^{106}Ru + ^{106}Rh$  dans divers types d'algues

## DESORPTION OF RADIOACTIVITY FROM THE NEARSHORE SEDIMENT

B. Patel, S. Patel, S. Pawar  
Health Physics Division

Bhabha Atomic Research Centre, Trombay, Bombay 400 085

## INTRODUCTION

The radioactive low level aqueous wastes originating from the fuel reprocessing facility at Trombay are being discharged after monitoring into the Bombay harbour (Fig.1). The present paper in continuation of our earlier publication (1), discusses the possible mechanism involved in the sorption-desorption of cesium-137, cerium-144 and ruthenium-106 from the sedimentary particles under environmental conditions.

## DISTRIBUTION OF RADIOACTIVITY IN THE BOMBAY HARBOUR SEDIMENT

In general, the concentration of cesium-137, cerium-144 and ruthenium-106 in the bed material was found dependant upon the ambient concentrations, which in turn were similarly dependant upon the release. The levels of radioactivity deposited were found to drop sharply with the distance from the discharge point. Thus the sedimentary radioactivity decreased by more than hundred times towards the mouth of the harbour, about 15-20 kms away from the discharge point and was beyond detection limit about 100 kms away.

During the present studies the absolute levels of all the three radionuclides in the surface sediment from the Trombay clam bed (Fig.1) were found to drop significantly with time (1971-76)-after reaching apparent peak concentrations in 1971-as is evident from Fig.2, which records the annual average concentration of the three nuclides. Similar drop, ranging from 50 to 70 % over a period of three years, in the sedimentary radioactivity was also observed over the entire 240 km<sup>2</sup> of the harbour bed as seen from Fig.1, which records the distribution pattern of cesium-137 in the bed material during 1971 and 1974. In the vertical profile of the bed also similar drop in the cesium activity, amounting to about 48-57%, was evident (Fig.3). It will be seen from the exponential decrease in the radioactivity (Fig.2), that the effective sedimentary half life ( $T_{eco}/2$ ) for cesium-137 works out to about 1.86 years, which is significantly shorter than its radiological half life (33

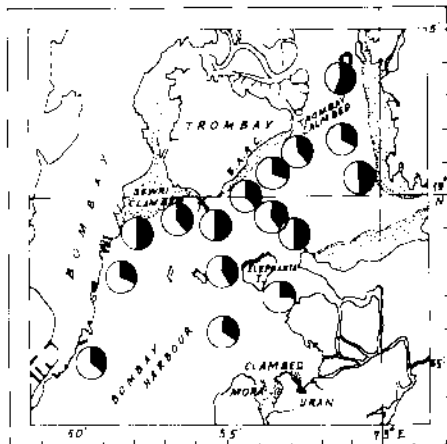

Fig. 1: Bombay Harbour and environment showing the clam beds and percent cesium 137 activity retained or desorbed from the bed material in March 1974, as compared to that observed during March '71. The full circle represents the observed concentration during 1971 and the shaded as the fraction retained during 1974 at various stations.

Fig. 1: Bombay Harbour and environment showing the clam beds and percent cesium 137 activity retained or desorbed from the bed material in March 1974, as compared to that observed during March '71. The full circle represents the observed concentration during 1971 and the shaded as the fraction retained during 1974 at various stations.

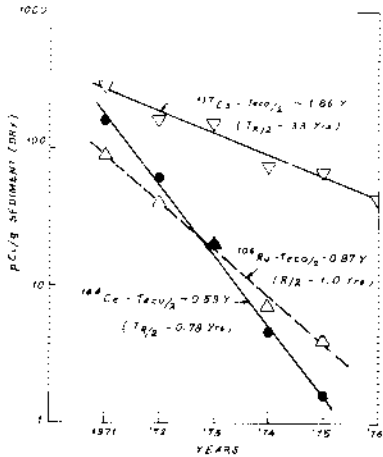

Fig. 2: Annual average distribution of cerium-144 (●), ruthenium-106 (Δ), and cesium-137 (▽) in the sediment from Trombay clam bed during 1971-76.

years). On the other hand, the effective sedimentary half life of ruthenium-106 and cerium-144 comes out as 0.87 and 0.59 years respectively, and are practically the same as their radiological half life (1.0 and 0.78 year). This clearly demonstrates the efficiency of the environment in the removal of cesium-137 from the sediment. The observed minor differences in case of ruthenium and cerium after allowing for their radiological decay could be due to the influx of fresh sediment rather than due to those causes which deplete radiocesium in the sediment. Assuming the sedimentary half lives of cerium and ruthenium to be meaningful and ruling out other parameters for the observed decrease in the sedimentary radioactivity, one could easily see that there is an influx of about 20% of fresh sediment. Allowing for this sedimentary influx, especially during

monsoon run-offs, and the natural decay of cesium-137, the observed effective half life of the radionuclide should have been about 26 years instead of 1.86 years, as has been observed (Fig. 2). It is tempting to suggest that the environment or some physico-bio-chemical properties of one or more of its constituents is playing a significant role in bringing

**MECHANISM OF SORPTION-DESORPTION**

The observed drop in radioactivity of the sediment may well be due to biotic and abiotic environmental parameters. These include the removal of radioactivity by heterotrophic bacteria and/or through the ingestion

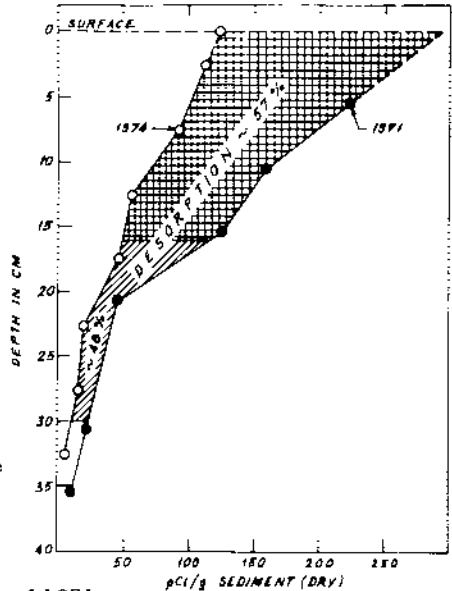

Fig. 3: Distribution of cesium-137 in vertical profile at a mid-stream station off the discharge zone in the Bombay harbour during March 1971 (●) and 1974 (○). Assuming the sedimentation rate of about 1 cm/year at the station, the profile for the year 1971 has been plotted with its surface layer about 3 cms deep with reference to the surface layer of 1971.



by benthic communities. The drop in activity to a certain extent, could also have been accentuated by the influx of fresh material and/or through the tidal currents leading to churning of the mobile layer of the sediment, which in turn may cause frictional detachment, and/or by the subsequent movement of the bed material from the area of higher or lower concentrations to the region under study. Notwithstanding these mechanisms, the desorption of some radionuclides (cobalt-60, zinc-65, cesium-137) from the sedimentary particles have been observed under laboratory conditions, with sufficient concentrations of radioactivity in the superincumbent sea water. Thus about 10% of cesium-137 was desorbed from the sediment-both original and one made free of organic matter- after 50 days of exposure and attaining peak sorption despite the presence of radioactivity in the medium (2).

The sorption mechanism of the radionuclides follow either isotopic exchange reaction with kinetics comparable to an ion-exchange type reaction or isotopic exchange through precipitation and dissolution reactions or a mixture of precipitation and ion-exchange reactions with formation of compounds. The sorption of cerium and ruthenium radionuclides is found through precipitation and formation of compounds, whereas that of cesium has been observed through an ion-exchange type of reaction either with potassium or magnesium or sodium (3). The sorption-desorption of various radionuclides also depend upon the crystal structure and the physico-chemical characteristics of the sedimentary particles and of the nuclides. The Bombay harbour sediment has a large quantity of clay mineral, especially illite (32-34%), the major exchangeable ion of which is potassium. It has high organic (3%) and iron-contents (7.5%), with a specific surface of 187-188  $m^2/g$  and the base exchange capacity of 46-47 meq./100 g. These characteristics of the sediment have been found to allow a ready sorption of the cesium radionuclides, the half-uptake time to reach an apparent equilibrium state being only 0.4 day (1, 3). The rates of sorption of cerium-144 and ruthenium-106 have been found relatively slow though these nuclides have higher sorption distribution coefficient ( $10^4-10^5$ ) than has cesium-137 ( $10^3$ , 1). Further the cesium sorption is found suppressed at higher salinity due to increased concentration of the exchangeable ions ( $K^+$ ,  $Na^+$ ,  $Mg^{++}$ ), which are known to reduce the binding sites of cesium on the clay (4). In the laboratory experiments, the desorption of cesium isotopes was found dependant upon the salinity, Fig. 3. The maximum desorption (40%) occurred at normal harbour salinity (38 ‰) and the minimum at the lowest salinity (9.5 ‰) studied, after 10 days of mechanical shaking. Thus the cesium desorption was found directly proportional to the exchangeable co-ion concentration. The salinity dependance of sorption-desorption of radiocesium further shows that with the influx of fresh water during monsoon (June-September), the retention of cesium by the sediment is relatively better than during the rest of the year. These observations incidentally explain our earlier findings that there was little change in the sedimentary radioactivity during and after monsoon, when the salinity was observed to go as far down as about 4-8 ‰ in the harbour (1).

The sediment on treatment with ammonium acetate pH 7.0, ammonium acetate/acetic acid (1:1) pH 5.4 and 5% EDTA pH 7.0, was found to desorb about 15-15, 22-26 and 15-24% radiocesium respectively within

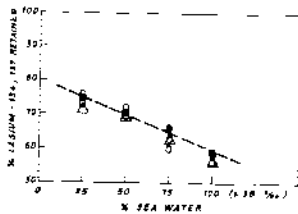

Fig. 4: Effect of salinity on desorption of cesium-134, 137 in the sediment from Bombay harbor (●-<sup>137</sup>Cs) & Tarapur (○-<sup>137</sup>Cs, △ - <sup>134</sup>Cs) after ten days of shaking under laboratory condition.

The desorption of these nuclides was not expected, since these are sorbed through complex reactions involving ion-exchange, precipitation and formation of compounds (5), which are difficult to solubilize at sea water pH. However, both the nuclides could be complexed (22-77%) with EDTA (6). The cesium radioactivity, on the other hand, could be easily desorbed or exchanged through the same ion-exchange mechanism working in either direction, when washed with sea water free of radioactivity or with very little cesium activity at sea water pH and at normal concentrations of exchangeable co-ions (K/Na/Mg). The former situation is expected when the sediment is transported from the contaminated to non-contaminated zones along the coast and later when the radioactivity discharges are extremely low/stabilized.

In general, our field and laboratory observations on the desorption - particularly of cesium - under depleted environmental conditions are contrary to those observed by others through laboratory experiments alone. We find that cesium sorbed on the marine sediment is readily desorbed under favourable environmental conditions, including the transportation of the sediment from the discharge zone to non-contaminated areas. This needs to be confirmed in other coastal environments, where fairly long residence time for cesium radionuclides has been predicted. This has recently become more imperative because of possible increased discharge of radioactive wastes in the coastal zones. The fact that the environment can decontaminate itself, as has been observed here, offers a possibility to revise the present levels of maximum permissible discharges especially those in which radiocesium dominates.

#### REFERENCES

1. Patel, B., C. D. Mulay, A. K. Ganguly: 1975. Estuarine & Coastal Marine Sciences, 3, 13-42.
2. Ganapathy, S., K. C. Pillai, A. K. Ganguly: 1968. Report BARC-376.
3. Duursma, E. K., D. Eisma: 1973. Netherland J. Sea Res. 6, 265-324.
4. Aston, S. R., E. K. Duursma: 1973. Ibid. 6, 225-240.
5. Duursma, E. K., M. G. Gross: 1971. Radioactivity in Marine Environment, U.S. Nat. Ac. Sc., Washington, D. C. 147-160.
6. Pillai, K. C., N. N. Dey, E. Mathew, B. U. Kothari: 1975. IAEA, Vienna, STI/PUB/406, 277-300.

## IMPACT DES ACTIVITES NUCLEAIRES SUR L'ENVIRONNEMENT

BILAN DES RECHERCHES SUR LES TRANSFERTS  
DANS LE MILIEU NATUREL

par

P. BOVARD et A. GRAUBY

Service d'Etudes et Recherches sur l'Environnement

Compte tenu de la faiblesse des rejets radioactifs et des concentrations observés dans l'environnement, la radioécologie a du orienter ses travaux sur les transferts des radionucléides considérés comme les plus nocifs et ce au travers d'un nombre de voies d'atteinte limité. Cette démarche a permis une étude approfondie des mécanismes de transfert pouvant servir de base à des études prospectives devenues indispensables avec le développement accéléré de l'Industrie Nucléaire.

Tous les types de rejets ont été pris en compte, qu'il s'agisse d'installations minières (Ra), de centrales électronucléaires (produits d'activation), ou d'usine de retraitement des combustibles irradiés (P.F.-Pu) et ce dans les milieux les plus divers : mers, lacs, estuaires, rivières.

La voie aquatique a été considérée comme la plus intéressante et, pour tenir compte de la spécificité de la situation française, un effort particulier a été fait dans le domaine du transfert par les eaux d'irrigation (Cs-Ra) et dans celui du transfert par la chaîne alimentaire marine (Cs, Ru et Pu).

Les résultats acquis par l'expérimentation ou par l'observation in situ font apparaître :

- . l'influence de la charge chimique non radioactive des effluents,
- . Pour certains radioéléments, l'influence de la forme physico-chimique, celle-ci pouvant varier dans le temps et dans l'espace et conditionner la disponibilité du radionucléide,
- . le rôle des espèces vivantes et leur sélectivité,
- . le rôle des sédiments et des sols et leurs capacités de fixation et de relargage.

Pour pouvoir disposer avant la mise en exploitation d'une vue prospective de l'évolution du milieu en fonction des rejets et suivre cette évolution après le démarrage, il était utile de disposer d'une méthode adaptée qui tienne compte de l'extrême hétérogénéité du milieu naturel.

L'objectif de ces études prévisionnelles est de :

- déterminer à partir des prévisions de rejets, le devenir des polluants dans le milieu et la chaîne alimentaire,
- quantifier les concentrations prévisibles, à moyen et à long terme,
- évaluer les conséquences qui peuvent en découler,
- formuler, en fonction des voies de transfert identifiées, des suggestions pour une surveillance efficace et économique,
- prévoir les conséquences des situations accidentelles dont la probabilité ne peut être négligée, et enfin,
- réaliser, après la mise en route des installations, un bilan écologique périodique.

La méthode préconisée comporte trois phases successives : l'analyse de la situation, la simulation et la synthèse écologique.

La première phase vise essentiellement à analyser les constituants physiques, biologiques et sociaux de l'Environnement et à les rapprocher des connaissances acquises en matière de transfert.

L'inventaire dressé à cette occasion doit comprendre, outre la description de l'état actuel de l'Environnement, un essai de prospective en fonction des équipements futurs, notamment dans le domaine agricole.

La première phase faisant toujours apparaître un certain nombre de manques dans les connaissances, pour y remédier, des simulations sont réalisées en laboratoire ou "in situ", c'est la seconde phase qui comprend aussi un "point zéro" dont le rôle doit être également de faciliter les contentieux ultérieurs.

La troisième phase ou synthèse écologique se fait en rassemblant les données de l'Inventaire, de la Simulation et les connaissances acquises par les recherches radioécologiques, ce qui permet de mieux comprendre les phénomènes complexes régissant la dispersion et la concentration des polluants.

La conclusion de ce travail de synthèse se traduit par la mise en évidence des paramètres et voies d'atteinte dominants qui vont, soit engendrer le risque potentiel, soit limiter les possibilités de rejets de l'installation et orienter le contrôle de l'environnement immédiat et lointain du Site.

Les études prévisionnelles ont d'abord été effectuées à l'échelon local pour une installation ou un site. Depuis, elles se sont élargies au cadre régional ou plutôt à celui des barrières écologiques pour tenir compte des interactions des sites amont et aval. Dans ce cas, il faut mettre en exergue les radioélé-

ments diffusibles ou transférables à longue distance. Le tritium et les iodes à vie longue par exemple, deviendront des paramètres principaux.

Il pourra se produire que des points d'accumulation privilégiés se constituent à des distances relativement élevées des installations du fait de la conjonction de plusieurs flux venant de sources différentes.

A titre d'illustration, est présenté le cas d'une installation rejetant de l'Iode 129 dans l'environnement. A priori, la voie de transfert prépondérante paraît être le lait.

Une analyse de la situation locale fait ressortir que, compte tenu de la composition du rejet et de la longue vie de l'isotope, il fallait tenir compte de la voie racinaire et également du rôle de la technologie agricole.

La bibliographie n'ayant pas permis d'établir un modèle de la distribution de l'Iode entre la voie foliaire et la voie racinaire, une simulation expérimentale a été réalisée qui a permis de mettre en évidence, un comportement différent de l'Iode selon sa forme physico-chimique.

L'Iode se trouve dans le milieu sous trois formes principales : Iode gazeux, Iodures et Hydroxydes. L'Iode gazeux qui peut représenter jusqu'à 35% de l'Iode total (en fonction des conditions locales), emprunte la voie foliaire alors que les Iodures et les Hydroxydes rejoignent le sol où on les retrouve sous formes d'Iodures organiques.

Au cours de la synthèse finale, la confrontation des données expérimentales et des données économiques sur la collecte et le traitement du lait, a permis de mettre en évidence une voie de transfert inattendue; la rivière collectrice des eaux usées de plusieurs laiteries dont l'estuaire relativement vaseux est un lieu de prédilection pour les coquillages consommés par la population. A long terme, la surveillance de ces coquillages sera plus importante que celle du lait lui-même.

ANALYSE ET PREVISIONS DES ECHANGES DE PRODUITS AGRICOLES  
 ENTRE DIFFERENTES REGIONES AFIN D'EVALUER LES CONTAMINATIONS  
 PAR LA CHAINE ALIMENTAIRE

C. MACCIA, P. MASTRE, P. PAGES, E. STEMMELEN  
 Commissariat à l'Energie Atomique  
 DPr/SEES  
 B.P. N° 6 92260 Fontenay-aux-Roses , France

°  
 ° °

## I. INTRODUCTION DU PROBLEME

Le processus à explorer concerne les transferts de contamination liés aux activités économiques et techniques situées entre producteurs et consommateurs de produits agricoles. Ces derniers, en effet, ne sont que très partiellement utilisés sur place et sont l'objet d'échanges interrégionaux et de transformations plus ou moins importantes au cours desquels la contamination des produits varie sensiblement.

Le territoire à étudier ayant été découpé en régions, on étudie les modifications que la contamination peut subir le long de la chaîne alimentaire et en outre on évalue l'importance relative de chaque contamination régionale (au niveau de la récolte) dans la contamination du produit finalement consommé, compte tenu des échanges et transformations subies.

Nous plaçant dans le cadre d'une planification du programme nucléaire, nous nous sommes également donné un objectif de type prospectif : prévoir les échanges de produits et les transferts de contamination dans un avenir proche (5 ans).

On aboutit à une simulation du phénomène à l'aide d'un modèle informatique du type conversationnel (en langage A.P.L.) qui fournit à l'horizon voulu, les contaminations finales dans les produits consommés, région par région, ainsi que les doses potentielles par régions et par tranches d'âge, sous les hypothèses de contaminations initiales introduites par l'utilisateur (1) (2).

## 2. DESCRIPTION DU PHENOMENE

Nous avons pris pour exemple le cas du blé tendre en France, dont la chaîne alimentaire est décrite par le schéma suivant :

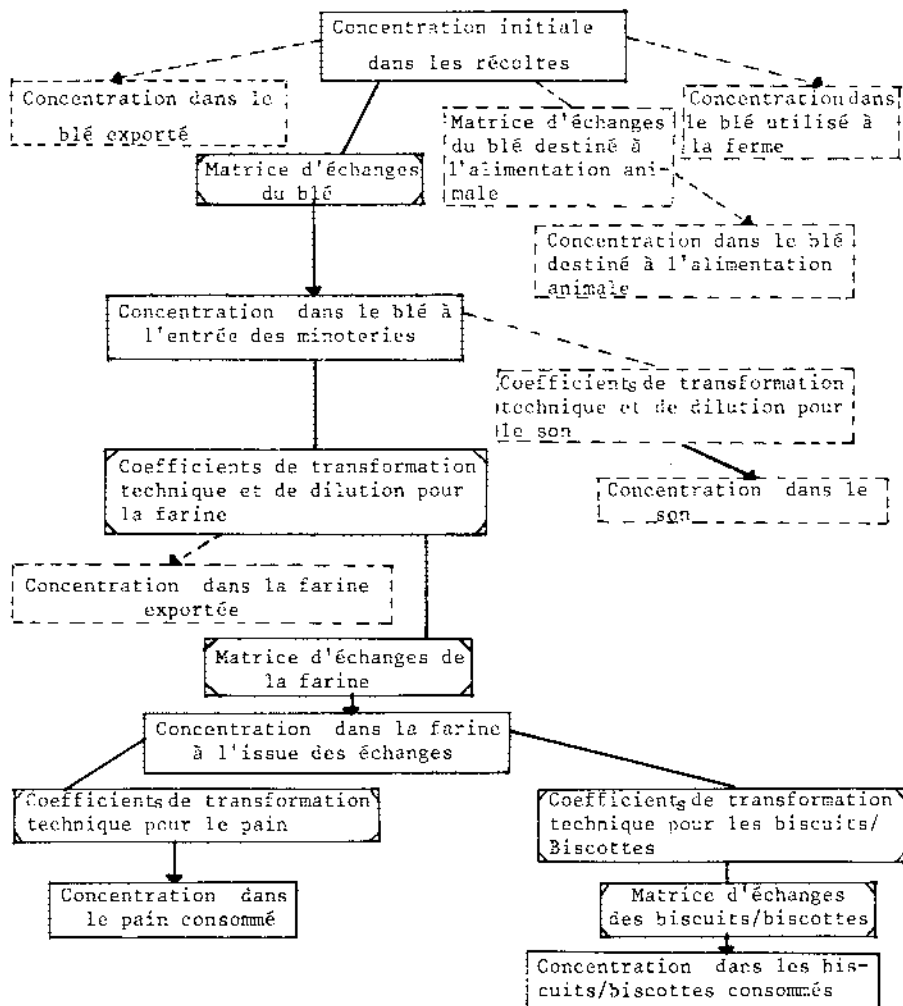

Chaque étape introduit une modification de la contamination et éventuellement de l'aspect physique du produit. Certains passages d'une étape à l'autre sont l'occasion d'échanges interrégionaux, caractérisés par des matrices d'échanges ; leur rôle est particulièrement important dans la diffusion de la contamination et il importe, dans une optique prévisionnelle, de connaître ces matrices à l'horizon souhaité.

### 3. ASPECT PREVISIONNEL

La prévision des échanges de blé et de farine a été effectuée après avoir expérimenté deux types de modèles économétriques :

1) des modèles "empiriques" construits à partir d'une étude systématique des divers coefficients pouvant caractériser la structure d'une matrice

d'échanges (3). Extrapolés à l'horizon voulu, ces coefficients peuvent être "ajustés" à l'aide de la méthode "R.A.S." aux productions et consommations régionales dont la prévision est étudiée par ailleurs.

2) des modèles "explicatifs" basés sur l'utilisation d'un programme linéaire de transport et la construction d'un "coût généralisé" d'échanges introduisant les divers paramètres physiques et économiques qui peuvent intervenir.

#### 4. LE CALCUL DES DOSES

Pour une contamination par un radionucléide donné -nous avons ici considéré l'Iode 129- les concentrations calculées dans les produits consommés permettent à l'aide de formules classiques (4) de déterminer les doses délivrées ; ces doses dépendent également de coefficients exprimant les effets du radionucléide selon l'âge du consommateur et les rations alimentaires (à l'horizon choisi). On évalue ainsi les risques auxquels pourraient être soumis les populations des différentes régions considérées.

On constate que les doses potentielles dépendent plus encore des quantités produites et échangées que des contaminations initiales. Nous avons par exemple observé que les effets d'une concentration initiale forte dans la Beauce (région de Chartres-Orléans) sont globalement plus importants (contamination sur l'ensemble du territoire français) que ceux d'une concentration énorme (30 fois plus élevée) dans la Normandie où se situe l'Usine de retraitement de La Hague (contamination élevée sur place et dans le Nord du Bassin Parisien uniquement).

On observe par ailleurs que, qu'elles que soient les hypothèses de contamination, la Beauce détient un rôle prépondérant dans le phénomène, car elle transmet -par le biais des échanges- sa contamination initiale à de multiples régions.

#### 5. CONCLUSION

Il ressort de cet étude que les échanges économiques jouent un rôle essentiel dans la diffusion de la contamination à travers la chaîne alimentaire du blé. De manière générale, il ne faut donc pas négliger cet aspect dans l'évaluation des risques auxquels sont soumises les populations lorsqu'on étudie, dans un but de radioprotection, les contaminations par la chaîne alimentaire.





ENVIRONMENTAL EFFECTS OF TIME DISTRIBUTION OF RELEASES

R. Schaeffer

Central Department for Safety in Nuclear Installations,  
Ministry of Industry and Research  
Paris, France

We compare (fig. 1) two extreme cases of time distribution of radionuclide releases in a waterstream : a) protracted releases, keeping the water volumic activity at a stable level  $C_1$  ; b) discontinuous releases of short duration  $\theta$ , repeated over equal time intervals with a period  $P$  ; they are shown by a succession of peaks of high water volumic activity level  $C_2$ .

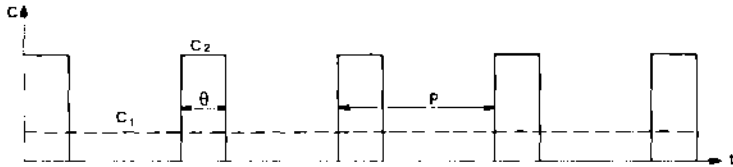

Fig. 1 - Volumic activity vs time, according to the release pattern.

The incidences of the releases are different according to the long or short half-lives of the radionuclides.

1. RELEASES OF LONG HALF-LIVED RADIONUCLIDES

These radionuclides are progressively accumulated in food products grown with river water (or in man getting his drinking water from the river), until the losses become important enough to balance the successive intakes. In the case of protracted releases, this accumulation of radioactivity (so-called "burden") is regular, whereas in the case of discontinuous releases it occurs according to a serrated curve oscillating around a mean value (fig. 2).

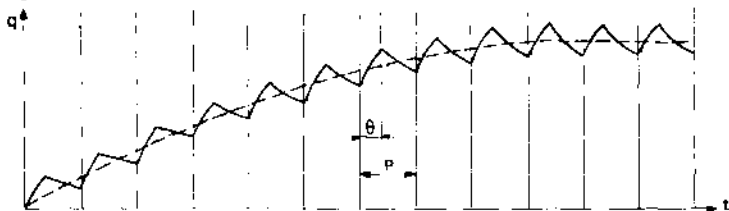

Fig. 2 - Burden vs time, in case of discontinuous releases of long half-lived radionuclides

The massic activity  $q$ , reached at equilibrium, can be expressed as follows :

- in case of protracted releases :  $q = \frac{f}{\lambda} C_1$  ; (a)

- in case of discontinuous releases :

$$\frac{f}{\lambda} C_2 \frac{e^{\lambda\theta} - 1}{e^{\lambda P} - 1} \leq q \leq \frac{f}{\lambda} C_2 \frac{1 - e^{-\lambda\theta}}{1 - e^{-\lambda P}}$$
 (b)

with, as mean value :

$$\bar{q} = \frac{f}{\lambda} C_2 \frac{\theta}{P}$$
 (c)

where  $f$  is the fraction of the water volumic activity which is transferred per time unit to the mass unit, and  $\lambda$  is the effective elimination constant (corresponding to an effective half-life  $T = 0,693/\lambda$ ). Some numerical values of  $f$  and  $T$  (1) are quoted as examples in table 1.

As the absorbed doses are always proportionnal to the mean activities, the comparison of both release patterns comes to compare the values of the expressions (a) and (c), consequently the values of  $C_1 P$  and  $C_2 \theta$ .

Since the latter two values are in inverse ratio to respectively the mean and the instantaneous river flow rate, one may conclude, with a view to population protection, that the discontinuous releases shall be equivalent to the protracted releases if they are effected when the flow rate is medium and more favourable when the flow rate is above average.

As to the burden fluctuations, expressed by the inequalities (b), they cannot have serious consequences: their relative significance, indeed, decreases quickly with radioactivity accumulation (fig. 2); at equilibrium they represent but a little fraction of the total burden (table 2).

	$f$ ( $d^{-1}$ )		$T$ (d)	
	$^{137}\text{Cs}$	$^{90}\text{Sr}$	$^{137}\text{Cs}$	$^{90}\text{Sr}$
	fish (edible part)	0.06	0.015	400
potato (sandy soil)*	0.005	0.003	7000	3500
salad (chalky soil)*	0.0025	0.002	11000	5300
man drinking river water**	0.017	0.015	70	6400

\*ecosystem soil + plant \*\*values for the critical organ

TABLE 1 - Values of  $f$  and  $T$

	Protracted releases		3-day quarterly releases in medium flow rate					
	$^{137}\text{Cs}$	$^{90}\text{Sr}$	$^{137}\text{Cs}$			$^{90}\text{Sr}$		
			min.	aver.	max.	min.	aver.	max.
river water	0.11	0.11	0	-	3.20	0	-	3.20
fish (edible part)	3.70	0.23	3.40	3.70	4.00	0.16	0.23	0.31
potato (sandy soil)	5.28	1.58	5.05	5.28	5.55	1.55	1.58	1.61
salad (chalky soil)	4.42	1.63	4.40	4.42	4.44	1.61	1.63	1.65
man drinking river water	0.18	14.60	0.11	0.18	0.27	14.55	14.60	14.65

TABLE 2 - Massic activities (pCi/kg) at equilibrium per curie yearly released (medium river flow rate: 300 m<sup>3</sup>/s)

## 2. RELEASES OF SHORT HALF-LIVED RADIONUCLIDES

Discontinuous releases have the drawback of producing large fluctuations of the burden, but the advantage of allowing radioactive decrease between releases. The balance between these two processes should be made.

### 2.1. Large Fluctuations of the Burden

As the short half-life prevents the accumulation of radioactivity, burden fluctuations keep their initial amplitude throughout all the successive releases (fig. 3 and table 3).

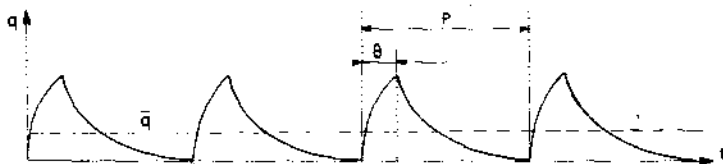

Fig. 3 - Burden vs time, in case of discontinuous releases of short half-lived radionuclides.

Protracted releases	3-day quarterly releases in medium flow rate		
	min.	aver.	max.
21.10	0.06	21.10	150.00

TABLE 3 - Thyroid massic activities (pCi/kg) in an individual drinking river water contaminated by 1 Ci iodine 131 yearly released (medium river flow rate : 300 m<sup>3</sup>/s).

Thus, high dose rates and consequently an increase of the risk of occurrence of radiopathological effects may result. Indeed, the dose-effect relationship is generally represented by a family of sigmoids (fig. 4) nearer to linearity as the exposure duration is shorter (2). If so, for an equal river flow rate, as compared to protracted releases, discontinuous releases should increase the radiopathological risk by a factor :

$$n = \frac{P}{\theta} \left[ 1 - \frac{1 + e^{-\lambda P} - e^{-\lambda \theta} - e^{-\lambda (P - \theta)}}{\lambda \theta (1 - e^{-\lambda P})} \right] \quad (d)$$

Figure 5 gives an example of the variation of this factor versus the annual number of releases.

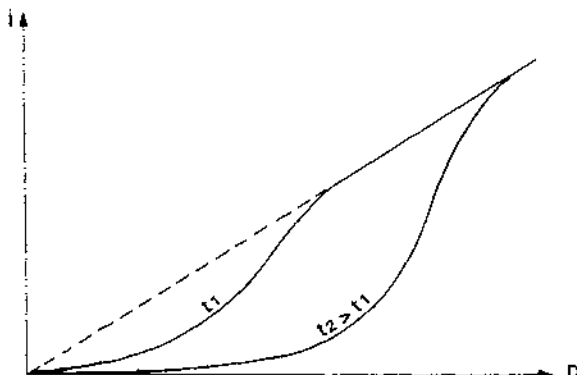

Fig. 4 - Dose-effect relationship according to the exposure duration t.

## 2.2. Radioactive Decrease between Releases

Sudden releases make it possible to empty a tank quickly and consequently to use its whole capacity in order to postpone the discharges as late as possible. Then, the activity of a nuclide with a radioactive constant  $\lambda_r$  is reduced by a factor :

$$\rho = \frac{1}{P} \left[ \theta + \frac{1 - e^{-\lambda_r (P - \theta)}}{\lambda_r} \right] \quad (e)$$

## 2.3. Final Assessment

The balance between the two processes is expressed by the product  $\eta \times \rho$ . In the example of figure 5, the optimum is located between 1 and 4 releases per year.

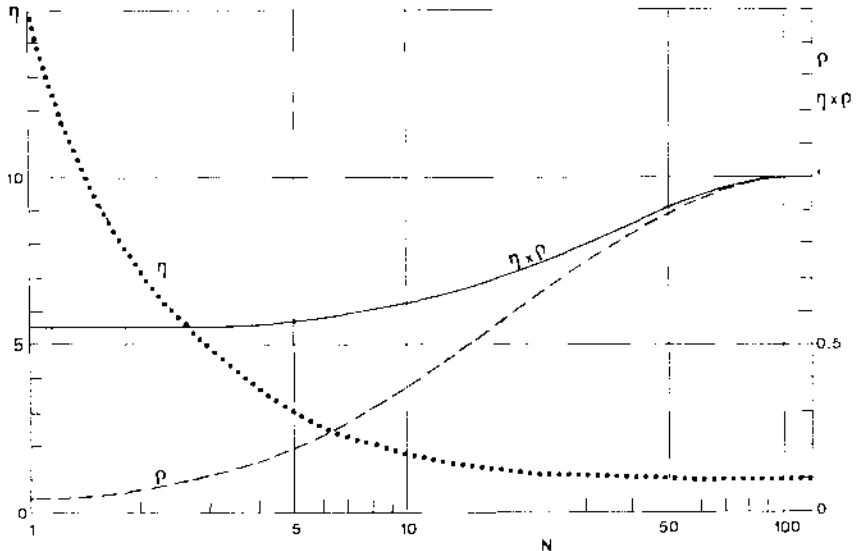

Fig. 5 - Values of  $\eta$ ,  $\rho$  and  $\eta \times \rho$  (see text) vs the annual number  $N$  of 3-day releases of iodine 131 in medium river flow rate, for an individual drinking river water.

## REFERENCES

- (1) SCHAEFFER, R. "Incidence des reconcentrations radioécologiques sur la valeur de la concentration maximale admissible des eaux de rivière". In : Population dose evaluation and standards for man and his environment. May 20-24, 1974. Vienna. A.I.E.A. 1974, 525-538.
- (2) SCHAEFFER, R. "Radiations et êtres vivants", Radioprotection, DUNOD, Paris, 1974, 9, 289-305.

## HIGH-LEVEL RADIOACTIVE WASTE DISPOSAL IN THE DEEP OCEAN

H. W. Hill

Fisheries Laboratory, Lowestoft, Suffolk, UK

## 1. INTRODUCTION

A programme has been initiated in the United Kingdom by the Fisheries Laboratory, Lowestoft (MAFF) to study the dispersion of radioactivity in the deep ocean arising from the possible dumping of high-level waste on the sea bed, in vitrified glass form, which would permit slow leakage over a long time scale. The programme consists of two parts, and is directed by a steering group set up by MAFF which also includes representation from British Nuclear Fuels Ltd and the National Radiological Protection Board. Shortly after its inception, representatives of the Institute of Oceanographic Sciences (IOS) joined the group in an advisory capacity. The first part of the programme consists of the development of a simple model which overcomes many of the criticisms of the earlier model proposed by Webb and Morley (1). The second part of the programme concerns the research cruises planned to measure the advection and diffusion parameters in the deeper layers of the ocean to provide realistic input data to the model and increase our fundamental understanding of the marine environment into which the radioactive materials may be released.

## 2. THE SHEPHERD MODEL

The Shepherd model (2) is concerned with the continuous release of radioactivity from a point source on the bed of a circulating finite ocean, which for convenience has the dimensions of the North Atlantic Ocean. The model includes horizontal and vertical diffusion and horizontal advection but not vertical advection. Both Fickian (normal, local diffusion where  $\nabla^2 = 2Kt$ ) and Okubo-Pritchard (more applicable to oceanic diffusion, including larger-scale eddies, where  $\nabla^2 = v^2 t^2$ ) representations of the diffusion process have been examined since there is reason to believe that non-Fickian diffusion is more appropriate in the oceans. It is found that there are differences in the concentrations arising from the use of the two types of diffusion but these do not seriously affect the main conclusions, and in general Fickian diffusion is used since this gives the higher concentrations and hence is the "safer" formulation. Shepherd's model estimates the equilibrium concentrations and relates these to the average concentration ( $S_0$ ) which would arise from a continuous release, maintained indefinitely, with complete and thorough mixing over the whole ocean. Results have been calculated for surface concentrations at 10 equally spaced points around the perimeter of the ocean and over depth profiles around the perimeter, which in this study is taken as the edge of the continental shelf. Thus maximum and minimum as well as mean concentrations can be calculated. Because diffusion and advection parameters are not particularly well known for the deep ocean, a range of values of these parameters has been used in the model in order to examine the effects on the results of values outside those generally believed to be the most likely estimates, although a range of vertical diffusion values only is shown in (2), this clearly being the most critical parameter of those examined.

In so far as coastal surface concentrations are concerned, the conclusions are that horizontal variations around the perimeter of the ocean are small, except for very rapid vertical diffusion (16 years vertical mixing time), and even then they are likely to be less than an order of magnitude different from the mean concentrations. Generally the concentrations are less, usually substantially less, than the well-mixed

concentration ( $S_0$ ), only slightly exceeding  $S_0$  in the case of very rapid vertical mixing and the shorter half-lives. For the most relevant cases, of mixing times of a few hundred years and half-lives greater than 30 years, horizontal variations may be taken as negligible and concentrations are normally between  $S_0$  and  $S_0/10$  (Fickian) and between  $S_0$  and  $S_0/100$  (Okubo-Pritchard). Certainly for half-lives of a few thousand years the surface coastal concentrations do not vary significantly from  $S_0$ .

Concentrations below the surface layer would also be generally less than the well mixed average ( $S_0$ ) at mid-ocean depths, using reasonably realistic estimates of the diffusion and advection parameters, and indeed it might be expected that above average concentrations would normally be found only within the bottom few hundred metres of a 5000 m deep ocean. Overall it would appear that we might expect fairly uniform concentration horizontally but that significant vertical stratification would occur, especially for those isotopes with half-lives less than 30 years. However, the bottom concentrations are unlikely to exceed  $S_0$  by more than a factor of 50 or so, except for a small area very close to the release point: and for the more interesting case of half-lives greater than 30 years and realistic vertical mixing times of a few hundred years, this factor is unlikely to be greater than about 10. Another important point to note is that although vertical advection is specifically excluded from the model, the effects of upwelling from the ocean floor cannot result in the surface layers of concentrations more than those which are expected on the bottom, i. e. even continuous upwelling, lasting for periods of the order of a half-life, should only result in an increase of concentration in the surface layer of about 10, for that particular isotope, at almost all locations.

Thus it would appear that satisfactory estimates of the levels of activity which can be safely deposited (in suitable packaging) on the sea floor can be made simply on the basis of the long term well-mixed average concentrations which would result, allowing a small safety factor for possible persistent upwelling and the above average concentration in the bottom few hundred metres, remembering that the shorter-lived isotopes, which have the highest bottom concentrations relative to  $S_0$  can be expected to decay considerably before significant leaking occurs from a well-designed package containing vitrified waste.

It is appropriate at this stage to compare the specific surface concentrations estimated by Shepherd's model with those of Grimwood and Webb (3), who now propose a slightly modified version of the Webb and Morley model to estimate the surface concentrations arising locally to the area of release in the short term coupled with a long term compartment model which becomes increasingly valid for times greater than 100 years or so after release until it approaches (at the order of 1000 years) the  $S_0$  levels of Shepherd's model, the levels to which all mixing type models must inevitably converge in the long term. In effect (in so far as the models are comparable) it can be shown that for half-lives between 30 and 3000 years, the surface concentrations over the disposal site, as predicted by Webb and Morley, do not vary by more than about one order of magnitude from the coastal surface concentrations calculated by Shepherd using, in the Shepherd model, the "most likely" estimate of vertical diffusion ( $10 \text{ cm}^2/\text{s}$ ). However, the radiological safety assessment associated with the original Webb-Morley model used concentrations 50 times lower than these to allow for dilution between the surface waters above the disposal area and the nearest fishing grounds. It may be concluded that their assessment of the maximum permissible rates of disposal should be reduced by between 10 and 50 times for half-lives less than 1000 years, and by substantially more for longer-lived nuclides, if Shepherd's proposal is accepted, viz that disposal rates be based on the long-term well-mixed average ( $S_0$ ). Shepherd's proposal is also rather more

conservative for the shorter half-lives than the results of Greenwood and Webb's short-term model and is equivalent to the results of their long-term compartment model for half-lives greater than 1000 years.

Some further development of models is planned but, even so, it should not be forgotten that these mixing-type models assume a slow continuous release, and that the steady mixing mechanisms represented mathematically by the diffusion theory are valid. They do not necessarily cater for instantaneous release of large amounts of activity by whatever means, e.g. an accident during dumping, "burping" of radioactivity due to the build-up of heat below the sea bed around an "in the bed" disposal, or subsequent concentration of activity in a specific hot spot by sediment or biota. Thus there is a real need to further our understanding of the small-scale and meso-scale oceanographic processes in the deep ocean, and it is to this end that the second part of the programme is, in part, directed although, clearly, one of the intentions of producing better models is that they should provide guidance on the relative worth of various oceanographic research programmes which might complement the modelling studies, either by indicating which were the critical oceanographic parameters needed for input or where observations might best be made to validate model predictions. Primarily, Shepherd's work suggests that the more important parameters may be vertical advection and diffusion but it is not clear at present how the former could be measured directly, and the latter is obviously difficult - but technically feasible, at least for small-scale diffusion. However, it is clear that there is also an urgent requirement to better understand the horizontal advective and diffusive processes in the deep ocean, and the equipment and expertise for the former, and possibly for the latter, already exist.

### 3. THE FIELD PROGRAMME

The steering group have concluded that the first priority should be the deployment of about 6 to 8 long-term full depth current meter stations at various locations in the north-east Atlantic selected for oceanographic reasons rather than as possible disposal sites. These stations would be maintained at 6 monthly intervals or so by a suitable vessel which would recover and redeploy the moorings, and it is felt that a minimum length of record of about 2 years is required at each site. In the general locality of these stations it would be sensible to carry out neutrally buoyant float experiments and make salinity-temperature-depth measurements to further our understanding of the formation, and frequency of occurrence, of deep ocean eddies (4) and study the velocity and density fields, particularly in and near the benthic boundary layer. It seems possible that small-scale diffusion experiments might also be possible using a radio tracer at depths below the level to which such data presently exist, viz about 1200 m.

Such a programme which might reasonably extend over 5 years at a cost of about £1½ x 10<sup>6</sup> would not solve all the problems of the dynamics of the deep ocean, but it is reasonable to think that we would then be in a better position to choose, more confidently, sensible locations for high-level waste dumping. Towards the end of the 5-year period we might also expect to be locating long-term current meters on these sites and studying the spatial variability around them with complementary shorter-term current meter arrays.

Fortunately there is a like interest, in so far as the long-term current meter stations are concerned, in SCOR WG 34 (the Working Group on Internal Dynamics of the Ocean), with which the steering group has established contact, and indeed it seems that profitable cooperation can be established here between MAFF, IOS, Kiel



University, Centre Océanologique de Bretagne and Laboratoire d'Océanographie Physique, Paris, proposals already being well advanced, in the North-East Atlantic Dynamics Study (NEADS), for the establishment of five such sites, which could be supplemented by others when funds are available, and could be recovered and redeployed by various research vessels operating within the group.

Financial support for the 5-year field programme, which it is hoped will involve extensive cooperation between MAFF and IOS, is not yet approved, but a start has been made within existing budgets related in MAFF to a low-level waste dumping project, and in IOS to the NEADS project, and has involved work in November-December 1976 by both RRS DISCOVERY (IOS) and RV CIROLANA (MAFF). During this period a long-term full depth current meter mooring was laid at  $46^{\circ}05'N$   $17^{\circ}11'W$  and three short-term bottom moorings were laid around this position within the NEA dump area. A number of neutrally buoyant floats were tracked through the area for periods up to 17 days. The current meter records have not been processed at the time of writing, but the floats appear to indicate a cyclonic eddy system below 3300 m in the southern part of the area, the floats moving first towards the west, then in a southerly, and later in an easterly direction with mean residual velocities (over 17 days) of 2.8-3.3 cm/s at 3300-3600 m, and 2.2-2.7 cm/s (over 13 days) near the bottom between 4200-4700 m. Towards the north of the experimental area a float was tracked at an estimated depth of 3648 m at a mean velocity of 3.4 cm/s in a north-westerly direction, for just under 7 days and two floats released near the centre of the experimental area at depths of 1000-1200 m, intended to be near the core of the Mediterranean Water, moved relatively rapidly towards the west and north-west at mean speeds of 8.8 and 7.7 cm/s for periods of 3 days 18 hours and 7 days 14 hours respectively. The mean residual current velocities indicated by the floats varied by up to 50% in magnitude during the tracking period. Two short hydrographic sections were made in the float tracking area in approximately north-south and east-west directions. The geostrophic velocities calculated from these hydrographic sections were reasonably consistent with the current field indicated by the floats. A bottom sediment core was also taken during the cruise at  $46^{\circ}07'N$   $17^{\circ}13'W$ . It is intended to use this core, and others to be taken on subsequent cruises, to investigate the adsorption of plutonium on to deep sea sediments.

#### 4. ACKNOWLEDGEMENT

The assistance of W. J. Gould, N. W. Millard and I. Waddington of IOS on RV CIROLANA, particularly during the float tracking work, is gratefully acknowledged.

#### REFERENCES

- (1) WEBB, G. A. M., MORLEY, F., A model for the evaluation of the deep ocean disposal of radioactive waste, Nat. Radiolog. Prot. Bd, Rep. (14) (1973)
- (2) SHEPHERD, J. G., A simple model for the dispersion of radioactive wastes dumped on the deep sea bed, Tech. Rep. MAFF Direct. Fish. Res. (29) (1976)
- (3) GRIMWOOD, P. D., WEBB, G. A. M., Assessment of the radiological protection aspects of disposal of high-level waste on the ocean floor, Nat. Radiolog. Prot. Bd, Rep. (48) (1977)
- (4) SWALLOW, J. C., Variable currents in mid-ocean, *Oceanus* 19, 3 (1976) 19

PERSPECTIVES POUR UNE GESTION INTEGREE  
DES DECHETS DE L'INDUSTRIE NUCLEAIRE

J.P. Clivier

Agence de l'OCDN pour l'Energie Nucléaire

1. INTRODUCTION

La première Conférence Nucléaire Européenne organisée à Paris avait pour thème la "Maturité de l'Energie Nucléaire". Tous les aspects relatifs à la production d'électricité d'origine nucléaire étaient inscrits au programme, y compris les questions liées à la gestion des déchets radioactifs. Dans l'esprit des organisateurs, le thème de la maturité choisi pour cette conférence correspondait très probablement au fait que la contribution du nucléaire à la production totale d'électricité des pays développés était devenue significative, voire même indispensable désormais, compte tenu de l'évolution générale sur le plan des ressources et des approvisionnements en énergie. Les réacteurs nucléaires fonctionnent en effet de façon relativement satisfaisante et leur nombre ne cesse de croître. La puissance installée dans les pays de l'OCDN sera de l'ordre de 150 GWe environ en 1980. Cependant, en ce qui concerne la partie terminale du cycle du combustible nucléaire, c'est-à-dire le retraitement des combustibles irradiés, le recyclage éventuel du plutonium et la gestion des déchets radioactifs, il semble qu'il soit encore prématuré de parler véritablement de maturité. Très peu de combustibles provenant de réacteurs à eau légère ont été retraités à ce jour, et l'on ne dispose par conséquent que d'une expérience relativement limitée pour ce type de combustible à taux de combustion élevé. Les aspects essentiels de la gestion des déchets radioactifs étant étroitement liés à ces opérations de retraitement, la mise au point de politiques générales dans ce domaine n'a pas encore véritablement présenté de caractère d'urgence dans la plupart des pays. Toutefois, cette situation est susceptible d'évoluer assez rapidement, notamment sous l'influence du public, et il convient d'envisager dès à présent quelles pourraient être les perspectives d'une gestion intégrée des déchets radioactifs dans le contexte d'un cycle du combustible nucléaire ayant atteint son plein développement industriel.

2. LA GESTION ACTUELLE DES DECHETS

Les travaux de recherche et de développement qui ont été effectués depuis une trentaine d'années ont permis d'accumuler des connaissances considérables en matière de traitement et de stockage des divers types de déchets radioactifs. Le problème des effluents gazeux et liquides qui sont rejetés dans l'environnement a constitué l'une des premières priorités à cet égard et l'on peut considérer

qu'il est à l'heure actuelle pratiquement résolu, dans la mesure où les doses d'exposition qui en résultent pour le public, restent à un niveau très faible. Toutefois, il conviendra, le moment venu, de limiter les rejets gazeux effectués par les installations de retraitement des combustibles irradiés. Le problème des effluents ne sera en fait pas traité dans cet exposé qui sera consacré au problème des déchets qui ne sont pas dispersés dans l'environnement.

## 2.1. Traitement, conditionnement et stockage des déchets

On peut affirmer désormais que les méthodes mises au point pour le traitement et le stockage des déchets radioactifs permettent de réaliser ces opérations de façon sûre et relativement économique pour la plupart des différents types de déchets produits. C'est le cas notamment des déchets produits par les réacteurs de puissance (quelques centaines de  $m^3$ /an par réacteur) dont on réalise le conditionnement par incorporation dans du béton ou du bitume. De nouvelles méthodes sont également mises au point pour l'incorporation de ces déchets dans des résines thermodurcissables ou des ciments imprégnés de polymères. Les déchets ainsi conditionnés sont en général stockés sur le site même des réacteurs avant leur évacuation.

En ce qui concerne les déchets provenant du retraitement des combustibles irradiés, la situation est plus complexe. Les déchets produits varient considérablement tant par leur niveau d'activité que par la forme sous laquelle ils sont obtenus. Des techniques de conditionnement existent pour la plupart de ces déchets, bien que certaines d'entre elles, notamment la vitrification des déchets de haute activité (quelques  $m^3$  pour la production annuelle d'un réacteur à eau légère), n'aient pas encore été expérimentées à l'échelle industrielle. Tous ces déchets sont stockés sur place de façon sûre dans l'attente d'une mise au point de solutions appropriées pour leur évacuation, ou d'un mode de conditionnement qui n'a pas encore fait l'objet de recherches suffisantes, ce qui est le cas pour les gaines de combustibles (quelques  $m^3$ ) et les déchets solides alpha (de quelques  $m^3$  à quelques dizaines de  $m^3$  pour la production annuelle d'un réacteur à eau légère).

Le conditionnement et le stockage des déchets radioactifs ont semblé jusqu'à présent être réglés le plus souvent au niveau de chaque installation nucléaire plutôt qu'au niveau national, en l'absence de politiques intégrées qui tiendraient compte aussi des questions d'évacuation.

## 2.2. Evacuation des déchets

Le traitement et le stockage sont certes une partie importante de la gestion des déchets, mais le véritable problème reste néanmoins celui de leur évacuation. A ce sujet, il convient de considérer deux grandes catégories de déchets radioactifs : d'une part, ceux contaminés essentiellement

par des produits d'activation et de fission dont la période radioactive n'exécède pas quelques dizaines d'années et dont la contamination en émetteurs alpha est nulle ou pratiquement négligeable ; c'est le cas notamment des déchets produits par les réacteurs nucléaires. D'autre part, les déchets contaminés éventuellement par des produits d'activation et de fission mais surtout par du plutonium et d'autres émetteurs alpha de très longue vie. De tels déchets sont représentés par la plupart de ceux provenant des installations de retraitement et de fabrication des combustibles au plutonium.

Pour la première catégorie de déchets qui sont en général d'activité faible ou moyenne, on dispose de deux méthodes d'évacuation qui sont relativement éprouvées et déjà appliquées à une échelle importante. Il s'agit de l'enfouissement dans le sol, près de la surface ou en profondeur, et du rejet en mer. Dans le premier cas, il convient d'assurer grâce au conditionnement des déchets et aux caractéristiques hydro-géologiques du site d'enfouissement, un confinement de la radioactivité sur des périodes de quelques centaines d'années. Dans le deuxième cas, la sécurité du rejet en mer n'est pas fondée sur le confinement de la radioactivité mais plutôt sur son relâchement partiel et progressif dans les masses d'eaux océaniques qui assurent ensuite une dispersion et une dilution à des niveaux négligeables.

Pour la seconde catégorie de déchets, c'est-à-dire ceux contaminés par les émetteurs alpha, le problème de l'évacuation et de l'élimination définitive est tout autre puisque leur toxicité va persister dans le temps sur des périodes qui peuvent s'étendre sur plusieurs centaines de milliers d'années. La mise au point de solutions à ce problème est de ce fait particulièrement délicate et la seule alternative possible à l'heure actuelle consiste à les stocker.

### 5. ELIMINATION DEFINITIVE DES DECHETS A VIE LONGUE

Le stockage des déchets à vie longue n'est évidemment qu'une solution provisoire. La recherche de solutions définitives se poursuit activement dans plusieurs directions dans le but d'éviter de transmettre aux générations futures la charge de la gestion de ces déchets et, en même temps, de faire en sorte que les solutions que l'on adoptera ne puissent avoir de conséquences graves à long terme.

La solution la plus étudiée et la plus avancée consiste à évacuer les déchets radioactifs dans des formations géologiques stables susceptibles, dans les conditions les plus défavorables, de garantir un confinement des déchets sur des périodes extrêmement longues. Cette possibilité fait à l'heure actuelle l'objet de travaux de recherche importants dans la plupart des pays de l'OCDE et l'on espère

qu'elle pourra être appliquée à grande échelle vers la fin du siècle. Divers types de formations géologiques présentent des caractéristiques favorables et les programmes en cours portent aussi bien sur les formations granitiques ou argileuses que sur les formations salines dont on pensait, il y a quelques années, qu'elles étaient les plus appropriées. Outre des expériences in situ ayant pour but de rassembler des données de base sur le milieu géologique lui-même, les programmes de recherches accordent une place de plus en plus grande aux études théoriques et aux modèles mathématiques pour évaluer l'importance des phénomènes éventuels de rupture du confinement géologique et de la migration résultante de la radioactivité. De telles études visant à démontrer la sécurité et le bien-fondé du concept d'évacuation en formations géologiques stables font l'objet d'une coopération très étroite sur le plan international.

Une autre méthode d'évacuation qui suscite un intérêt de plus en plus grand sur le plan international, consisterait à placer les déchets radioactifs à vie longue sous le fond de l'océan où ils seraient confinés dans des couches de sédiments ou d'autres couches géologiques appropriées. Il ne s'agirait pas, comme dans le cas des déchets de faible et moyenne activité qui sont actuellement rejetés en mer, de compter sur le potentiel de dispersion et de dilution des masses d'eaux océaniques, mais bien effectivement de réaliser un confinement aussi parfait que possible de ces déchets dans les formations sous-marines, en tirant parti de leur stabilité et de leur potentiel de rétention des ions radioactifs. La mise au point de la technologie nécessaire, de même que les études de sécurité, demanderont de toute évidence une période assez longue avant qu'il ne soit possible d'envisager une évacuation réelle de déchets dans de telles conditions.

D'autres techniques plus sophistiquées sont également envisagées, telle que l'évacuation dans l'espace ou la transmutation des radionucléides à vie longue. Cette dernière méthode semble a priori la plus intéressante mais elle suppose la séparation préalable et la concentration des émetteurs alpha, ce qui soulève des problèmes technologiques considérables et il n'est pas certain qu'une telle opération s'avère finalement rentable sur le plan de la sécurité aussi bien que sur le plan économique. De toute façon, des études se poursuivent également sur ces différentes possibilités.

#### 4. EVOLUTION DE LA GESTION DES DECHETS

La situation présente caractérisée par des mesures provisoires pour des catégories de déchets les plus critiques ne pourra pas se prolonger indéfiniment compte tenu, d'une part, de l'accroissement considérable du volume des déchets produits et, d'autre part, des pressions diverses qui visent

à la mise sur pied rapide de solutions au problème des déchets. Il conviendra donc d'organiser la gestion future des déchets de façon telle qu'elle soit sûre non seulement pour les générations actuelles, ce qui est déjà le cas, mais aussi qu'elle n'hypothèque pas l'avenir, tout en restant relativement économique. Des mesures devront donc être prises tant au plan national qu'international pour que la gestion des déchets soit, d'une part, intégrée au maximum dans le cadre des activités nucléaires, c'est-à-dire qu'elle tienne compte de tous les impératifs d'ordre sanitaire, technique et économique qui pèsent sur l'industrie nucléaire et, d'autre part, qu'elle soit convenablement réglementée, notamment pour tenir compte des risques potentiels à très long terme.

Sur le plan national, il conviendra de promouvoir des méthodes de traitement compatibles avec les conditions de stockage et d'évacuation envisagées pour les déchets. Il conviendra en particulier de se préoccuper en premier lieu de l'évacuation des déchets produits par les réacteurs et de choisir des méthodes de traitement permettant d'obtenir des produits adaptés soit à l'enfouissement dans le sol, soit au rejet en mer. Compte tenu de l'importance des volumes de déchets de faible et moyenne activité résultant de l'exploitation des réacteurs ainsi que des contraintes relativement modestes imposées pour l'évacuation de la plupart d'entre eux, chaque pays aura vraisemblablement intérêt à rechercher une solution nationale. Il semble en effet inutile, sauf pour le rejet en mer, d'envisager une solution internationale pour ce type de déchets.

Sur le plan international, le problème le plus important est lié au fait qu'un petit nombre de pays seulement procéderont, pendant un certain temps tout au moins, au retraitement des combustibles irradiés disponibles sur le marché international. En l'absence de solution pour l'évacuation des déchets de haute activité, ces pays se réservent pour l'instant la possibilité de retourner des déchets aux pays d'origine des combustibles irradiés. Une telle politique serait susceptible d'entraîner une prolifération des transports et des sites de stockage et d'évacuation pour les déchets de haute activité, ce qu'il serait probablement souhaitable d'éviter pour des raisons de sécurité. Un moyen d'y remédier pourrait être de faire appel à des solutions internationales pour l'évacuation des déchets de haute activité et des déchets alpha en utilisant par exemple des formations géologiques particulièrement appropriées pour la création de sites internationaux. La situation relative au retraitement du combustible irradié et les doutes qui ont été émis récemment quant au bien-fondé de ce retraitement, ainsi que les difficultés politiques prévisibles ne permettent pas d'envisager toutefois un progrès rapide dans ce domaine. Il n'en reste pas moins que ces problèmes devront être abordés tôt ou tard au niveau international de façon

qu'ils puissent être réglés dans l'intérêt de tous les pays, qu'ils soient ou non exploitants d'usines de retraitement.

#### 9. POLITIQUES PREVISIBLES

Les politiques qui devront découler d'une organisation plus intégrée de la gestion des déchets radioactifs, seront fondées en premier lieu sur une définition plus précise des responsabilités des gouvernements et de l'industrie nucléaire. D'une façon générale on considère que le problème de la gestion à long terme des déchets ne peut être réglé sans les garanties les plus élevées sur le plan de la sécurité. C'est-à-dire en pratique sans un contrôle gouvernemental aussi efficace que possible. L'évacuation des déchets ne pourra en particulier s'effectuer que sous la responsabilité directe des gouvernements qui s'assurent de la sécurité de ces opérations, du maintien d'archives et d'une surveillance appropriée des sites d'évacuation aussi longtemps qu'il sera nécessaire. Il n'est pas possible, sur des périodes de l'ordre de milliers et à fortiori de centaines de milliers d'années, d'envisager le maintien d'un contrôle sous une forme quelconque. Cependant, dans la mesure où un contrôle est souhaitable pendant une certaine période, la seule alternative possible est effectivement qu'il soit exercé par les gouvernements.

Dans de telles conditions, les responsabilités des firmes industrielles exploitant des installations nucléaires seraient limitées à la gestion à court terme des déchets radioactifs. Les exploitants des installations nucléaires auraient essentiellement pour tâche de traiter les déchets, de les stocker provisoirement, puis de les transporter dans des délais appropriés vers des sites d'évacuation gérés par les autorités gouvernementales. Ainsi, dans le cas des déchets de haute activité, les exploitants des installations de retraitement seraient responsables du traitement et de la solidification des déchets ainsi que de leur transport jusqu'aux sites d'évacuation, les autorités gouvernementales prenant ensuite la relève pour assurer la pérennité et la sécurité du confinement dans les formations géologiques choisies.

Le coût des opérations d'évacuation des déchets radioactifs qui n'intervient en général que longtemps après la production, n'est pour l'instant pas prévu dans les mécanismes de financement des diverses opérations liées à l'énergie nucléaire. Les ressources nécessaires aux activités de recherche et de développement ainsi qu'aux opérations d'évacuation des déchets de haute activité seront cependant considérables, même si l'on s'accorde à penser que le coût de gestion des déchets ne dépassera pas 1 % du coût total de production de l'électricité d'origine nucléaire. Il conviendra donc vraisemblablement de prévoir des mécanismes qui permettront d'assurer un financement

approprié de la gestion à long terme des déchets radioactifs, compte tenu notamment du fait que les opérations d'évacuation pourront intervenir seulement une décennie ou plus après la production des déchets. A ce sujet, il a déjà été envisagé de prélever une taxe éventuelle au niveau de la production d'électricité en vertu du principe "pollueur-payeur", cette taxe servant à alimenter un fonds destiné à financer les opérations d'évacuation ultérieure.

De telles dispositions d'ordre administratif et juridique doivent évidemment s'appuyer sur des considérations techniques et économiques valables, et il conviendra bien entendu de poursuivre les travaux de recherche et de développement en cours dans le domaine de la gestion des déchets radioactifs. A ce sujet, les mécanismes envisagés pour le financement de la gestion des déchets pourraient également être utilisés pour le financement de ces travaux de recherche et de développement. Le problème du déclassement et du démantèlement des installations nucléaires pose à cet égard des problèmes similaires.

Des accords internationaux semblent enfin inéluctables notamment en ce qui concerne les déchets radioactifs à longue vie, et la mise au point ainsi que l'application de solutions d'évacuation pour ces déchets dans le cadre de collaborations régionales. Il semble en tout état de cause que de tels accords ne pourraient être que le prolongement logique de ceux déjà existants ou à mettre sur pied en ce qui concerne le cycle du combustible nucléaire dans son ensemble et en particulier les approvisionnements en combustible.

## 6. CONCLUSIONS

Dans l'évolution actuelle de la situation relative aux déchets radioactifs, on constate que les problèmes "politiques" prennent une importance de plus en plus grande par rapport à la technologie et à la recherche qui étaient jusqu'alors au premier plan. Une telle évolution est révélatrice de l'importance que l'on attache au problème de l'évacuation des déchets radioactifs et traduit la volonté des autorités de mettre sur pied un cadre administratif, juridique et financier qui permette d'offrir un maximum de garanties pour l'avenir. Le problème n'en reste pas moins celui de l'évacuation des déchets et particulièrement celui des déchets contaminés par des émetteurs alpha et c'est dans ce domaine plutôt que dans celui du traitement et du stockage qu'il est nécessaire de faire porter désormais les efforts. Il existe déjà une base solide permettant de fonder des espoirs raisonnables en ce qui concerne la disponibilité de solutions appropriées et dont la sécurité serait suffisamment prouvée dans un délai de quelques dizaines d'années au maximum. Dans l'intervalle, l'industrie nucléaire dispose des moyens nécessaires pour assurer une gestion satisfaisante des déchets et les autorités ne manqueront probablement pas de mettre cette période à profit pour définir des politiques à long terme aussi bien sur le plan national que sur le plan international.



## A QUANTITATIVE ASSESSMENT OF NUCLEAR INCINERATION OF ACTINIDE WASTE

G. A. Harte and R. H. Clarke

Central Electricity Generating Board, Berkeley Nuclear Laboratories,  
Berkeley, Gloucestershire, UK.

## ABSTRACT

The actinides neptunium, americium and curium, control the long-term hazards of reprocessing wastes from almost all reactor types. A study has been made of the effect on the hazard of removal of these isotopes from the high level waste stream and of their reirradiation in the core (a) of a notional light water reactor, LWR (b) of a notional liquid sodium cooled fast breeder reactor, LMFBR.

## 1. INTRODUCTION

It is current practice in the United Kingdom to reprocess irradiated reactor fuel to recover both plutonium and depleted uranium. The high-level wastes from reprocessing consist of an acidic solution containing the fission products, residual uranium and plutonium, and other actinides the major components of which are neptunium, americium and curium. The fission products form the most hazardous group of nuclides for the first few hundred years, but the long term hazard is dominated by the actinides and in this paper one means of reducing the long term hazard will be explored. The hazard associated with an isotope will be defined as that volume of water ( $m^3$ ) required to dilute the isotope to its maximum permissible concentration in water for ingestion by continuously occupationally exposed individuals (1,2). Where a mixture of isotopes is considered the values of hazard for each isotope will be added to give a figure which is a total measure of the hazard regardless of pathways to man and assumed critical organs.

Because of the long periods needed for the decay of the actinides, it has been suggested that they be removed from the shorter-lived fission products and disposed of separately. Claiborne (3) suggested that the actinides be returned to the core of a reactor to undergo fission to shorter-lived species. This is known as "incineration", and this process has been the subject of this study.

## 2. COOLING PROPERTIES OF WASTES

Figure 1 shows the long-term hazards of reprocessing wastes from an LWR broken down into contributions from fission products, residual uranium and plutonium, and Np, Am and Cm, in order to see whether the removal of the latter from the waste will effect any worthwhile reduction in overall hazard. The quantity of waste considered is that arising from the generation of one GW(e)-year of electricity. In Table 1 the assumed operating conditions of the LWR, and of the LMFBR also considered in this study, are given. It will be seen from Figure 1 that the contribution of Np, Am and Cm to the waste hazard (Curve 2), is larger after 300 years than that of any other component, even if one per cent uranium and plutonium are sent to waste. If 99.9% U and Pu were to be removed from LWR fuel in reprocessing and if, say, 99% Np, Am and Cm were then separated from the waste and successfully incinerated, a worthwhile hazard reduction of nearly two orders of magnitude could be obtained at all cooling times.

Figure 2 shows the cooling properties of waste from a fast reactor operating on fuel that is 80%  $UO_2$  (containing 0.4%  $^{235}U$ ) and 20%  $PuO_2$ , the plutonium having been derived from an advanced thermal reactor and stored

four years before use. Np, Am and Cm now make an even larger contribution to the waste hazards, (Curve 2), so that once again their removal and incineration provide an attractive means of reducing the long term hazard, especially if at least 99.9% U and Pu have been removed in reprocessing (Curve 4).

### 3. INCINERATION STUDIES

Light water reactors are already in operation, whilst worldwide the fast reactor programme is still in its initial stages. It would be extremely useful if Np, Am and Cm from the LWR could be incinerated by reirradiation in the same reactor, though it is of course to be expected that with the more favourable fission-to-capture ratios obtainable in a fast flux and with the higher flux densities obtainable, the LMFBR will provide the more effective incinerator.

In Figure 3, Curve 1 shows the hazard associated with the Np, Am and Cm produced by an LWR in generating 1 GW(e)-year of electricity. Curve 2 shows the hazard associated with the same mixture of actinides after 20 years in an LWR core at a flux of  $3 \times 10^{14}$  neutrons  $\text{cm}^{-2} \text{s}^{-1}$ . The incineration was assumed to have been carried out in four five-year stages, five years residence in the reactor being succeeded by a 200 day cooling period during which it was assumed that the fuel elements containing the wastes were stripped down and refabricated. It will be seen that scarcely any long-term benefit is to be obtained from this 20-year incineration. Eight such five-year cycles would however reduce the long-term hazard associated with the Np, Am and Cm below that of the long-lived fission products. The LWR considered here produces nearly 20 kilograms of Np, Am and Cm per GW(e)-year, the total charge of waste to the core of a 1000MW(e) LWR incinerating Np, Am and Cm would thus be about 0.75 tonne in equilibrium.

In Figure 4, Curve 1 once again shows the hazard associated with the Np, Am and Cm from an LWR. Curves 2 and 3 show the hazard of these actinides after (a) a 20 year (4 x 5 year cycles) incineration in an LMFBR at a flux  $10^{16}$  neutrons  $\text{cm}^{-2} \text{s}^{-1}$ ; (b) a 40 year (8 x 5 year cycles) incineration in an LWR at flux  $3 \times 10^{14}$  neutrons  $\text{cm}^{-2} \text{s}^{-1}$ . The figure unequivocally demonstrates the superiority of the fast reactor as an incinerator, since the shorter period in the LMFBR has achieved the larger hazard reduction.

Finally, Figure 5 shows the effect of a 20 year LMFBR incineration on the hazards of Np, Am and Cm produced in 1 GW(e)-year by an LWR. The 20 year incineration achieves quite a dramatic hazard reduction bringing the hazard of the incinerated actinides down to those of the long-lived fission products and even a 15 year irradiation achieves 2 orders of magnitude reduction. The LMFBR produces approximately 50 kilos of Np, Am and Cm per GW(e)-year so that, assuming 20 year incinerations, the incinerating reactor would contain approximately one tonne of actinide wastes at equilibrium.

### 4. CONCLUSIONS

At cooling times beyond a few hundred years, the actinides Np, Am and Cm are the most hazardous components of waste from LWR and from LMFBR fuel. If 99.9% of uranium and plutonium has been removed in reprocessing, then the hazard of the Np, Am and Cm would have to be reduced by approximately two orders of magnitude to bring it to the level of the residual uranium and plutonium and of the long-lived fission products. The hazard of the Np, Am, and Cm produced in the LWR can be reduced by this amount by a forty-year irradiation in the LWR, at a flux of  $3 \times 10^{14}$  neutrons  $\text{cm}^{-2} \text{s}^{-1}$ . However, the LMFBR is the better incinerator and a slightly greater reduction can be

achieved by a 20-year irradiation in an LMFBR core at a flux of  $10^{15}$  neutrons  $\text{cm}^{-2} \text{ s}^{-1}$ . The hazards of the Np, Am and Cm produced in an LMFBR can be reduced by nearly three orders of magnitude by a similar 20-year irradiation in the LMFBR core, and a 15-year irradiation will reduce the hazard to the level of the residual 0.1% U and Pu assumed to be left in the wastes after reprocessing. A description of the techniques used in obtaining the results presented here has been given elsewhere(4).

REFERENCES

1. ICRP Publication 2, pub. Pergamon Press, (1959).
2. ICRP Publication 6, pub. Pergamon Press, (1964).
3. CALBORNE, H.C., "Neutron Induced Transmutation of High Level Radioactive Waste", ORNL-TM-3964, (1972).
4. HARTE, G.A. and CLARKE, R.H., "An Investigation into the use of a Fast Breeder Reactor to Incinerate Actinide Waste from the UK Nuclear Power Programme", CEBG Report No. RD/B/N3903, (1977).

ACKNOWLEDGMENT This paper is published by permission of the Central Electricity Generating Board.

Reactor Type	LWR	LMFBR
Fuel	UO <sub>2</sub> ; 3.1% <sup>235</sup> U	20% PuO <sub>2</sub> 80% UO <sub>2</sub>
Burnup (Mwd/te)	28,000	70,000
Rating (MW/te)	34	160
Station Efficiency %	31	42
Fuel Te/GW(e)-y	42	12.5

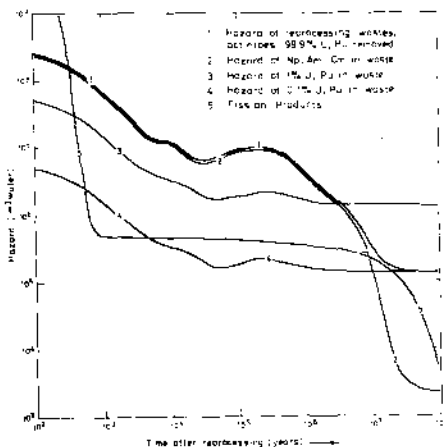

E.g. Long term hazards of wastes from a Light Water Reactor (per GW(e) Year Electricity Generated).

TABLE 1 Reactor Parameters

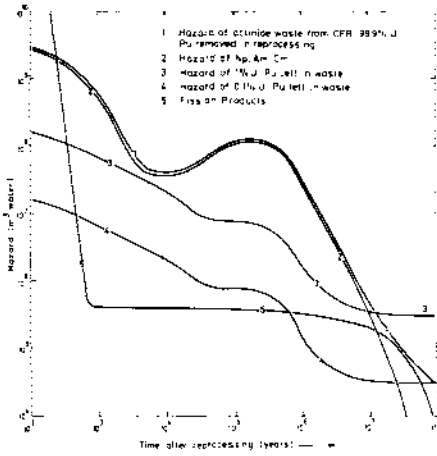

FIG. 2 LMFBR Components of Waste Beyond 100 y per GW(e) Year Electricity Generated.

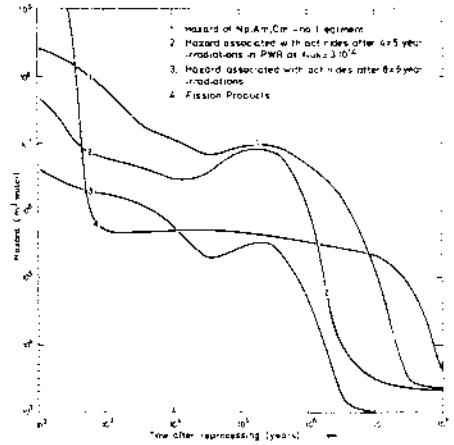

FIG. 3 The Incineration of Np, Am, Cm Produced by an LWR in an LWR

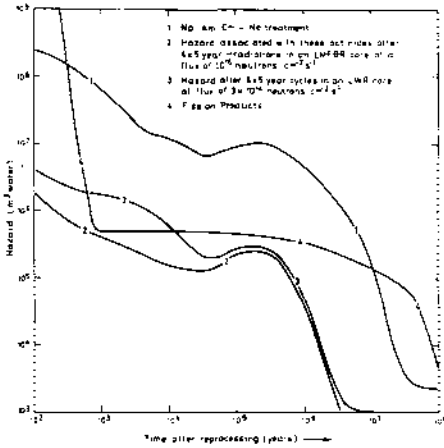

FIG. 4 The Incineration of Np, Am, Cm Produced by LWR per GW(e) year in LMFBR

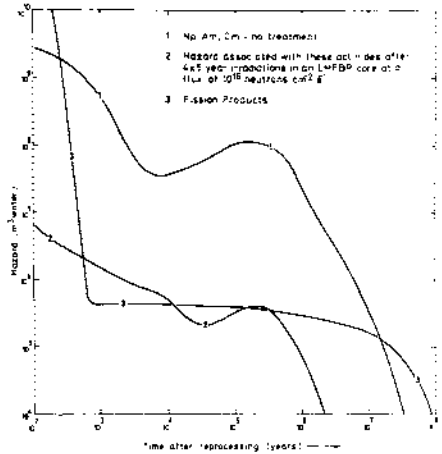

FIG. 5 The Incineration of Waste Np, Am, Cm Produced by an LMFBR per GW(e) year in LMFBR

## A RAD WASTE COMPACTIION PROGRAM FOR A MEDICAL CENTER

Kenneth L. Miller, Lottie A. Varano, Barry H. Brosey

Milton S. Hershey Medical Center  
 Pennsylvania State University  
 500 University Drive  
 Hershey, Pennsylvania U.S.A. 17033

## 1. INTRODUCTION

In the early stages of our programs growth and development (1) our waste handling problems were not of a major concern. We had approximately 65 radioisotope laboratories which were moderately active in conducting biological research. The total number of drums of radioactive waste generated required one and sometimes two waste shipments per year to a nearby radioactive waste burial site. The closeness of the burial site permitted us to rent a truck and act as private carriers on round trips that normally took no more than a day. Waste burial costs of approximately 85¢/ft<sup>3</sup> did not put a major strain on our operating budgets.

Unfortunately, this unpressured operating situation was short-lived. Opening of the hospital and clinical section plus additions to the physical plant and the biological research programs added tremendously to the utilization of radioisotopes. We suddenly found ourselves with the need to dispose of over 600 thirty gallon drums of radioactive waste per year. To make matters worse, our nearby commercial burial site closed, forcing us to ship to an alternate site several states away. Lack of adequate storage space, increased costs of commercial shipping and an inflationary spiraling, which quadrupled burial costs, forced us to initiate a waste volume reduction program. As an alternative to increasing environmental contamination through increased incineration and disposal via the sanitary sewer, we decided on a waste compaction program. Our compactor which is shown in Figure 1, has been in operation for over a year and has proven to be economical and effective. The various features of the compaction program will hence forth be discussed.

## 2. COMPACTOR FACILITY

After reviewing numerous commercially available compactors, we chose the Model 55A RAM FLAT Compactor manufactured by S & G Enterprises, Inc. of Milwaukee, Wisconsin. The features we liked best about this compactor included: (a) it is designed to meet OSHA requirements, (b) the drum is totally enclosed during compaction by a 3/8" thick steel plate door, (c) the unit generates up to 85000 pounds of compaction force with compaction ratios up to 10:1, (d) the use of a modified compaction head permits compaction within a 55 gallon steel drum. Undesirable features included: (a) the necessity of partially removing the drum from the compactor each time more waste is added, (b) the need to add progressively smaller volumes to the drums as they begin to fill, (c) the generation of airborne contamination through compaction. This latter problem necessitated the addition of a filtration system to eliminate odors and airborne contamination.

### 3. TYPES OF COMPACTIBLE WASTE

The types of wastes which we have found suitable for compaction in this system include most of the dry compactibles, i.e. disposables gloves, absorbent pads, paper, glassware, plastics, syringes, and other dry materials. Large objects which will not fit in the drums and rigid objects such as metals which could penetrate or cause distortion of the drums or damage to the compactor must be handled in an alternate manner.

### 4. COMPACTION EFFECTIVENESS

Although the system can give compaction ratios of up to 10:1, we have found in actual practice that we are achieving average compactions of 4:1. This difference is due primarily to the types of waste which we are compacting and the difficulties previously mentioned regarding adding waste as the drum begins to fill. The weight of a drum filled with compacted laboratory waste ranges between 300 and 500 pounds.

### 5. FILTERING SYSTEM

Compaction of radioactive waste in this unit does lead to airborne contamination and odors during use because there is a small space between the compaction head and the inside of the drum. In actual practice airborne concentrations were measured which approached MPC<sub>a</sub> (2) when compacting wastes containing several millicuries of total activity from isotopes of H<sup>3</sup>, C<sup>14</sup>, P<sup>32</sup>, and S<sup>35</sup>. In our situation this airborne contamination and odor problem was worsened by a poorly ventilated waste storage room.

To solve this problem we decided to provide the compaction chamber with the ventilating system which is shown in Figure 2. A hole was cut into the compaction chamber and the chamber was exhausted through a filter bank containing a throw-a-way type fiberglass roughing filter backed by a HEPA filter and an activated charcoal filter. A 600 CFM blower provides sufficient air movement to exhaust the compaction chamber while maintaining an air flow into the chamber which averages 1000 fpm. The exhaust air is vented straight to the outside.



Figure 1. Waste Compactor and Filter Bank in Compaction Room.

Since adding the ventilating system, we have eliminated the odor problem and the problem with airborne contamination outside the compaction chamber. Subsequent measurements have shown the filter bank is successful in removing all radioactivity from the air which is exhausted to the outside.

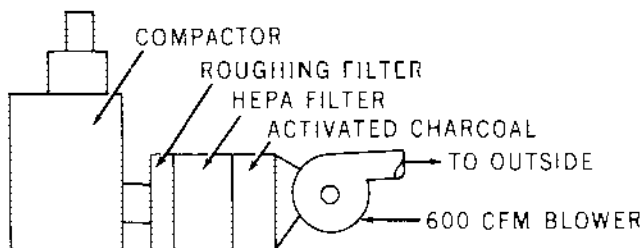

Figure 2. Compactor Ventilation System.

## 6. COST ANALYSIS

Prior to initiation of the compaction program, we were providing the laboratories with DOT approved fibre broad containers which were simply capped and made ready for shipment when full. The average cost of each container was \$7.35. Since installation of the compactor, we have replaced these containers with 17 gallon metal cans, with lids, which we were able to purchase from Navy Surplus for 25¢ each. For an added nominal fee we were able to have these cans painted lemon yellow and have radioactive material warning labels attached. A plastic bag liner permits easy removal of the waste each time the container is filled and eliminates the need for dumping. This smaller size, also, makes it easier to load the waste into the larger steel drums for compaction. Replacing the more expensive containers in the labs resulted in an appreciable yearly savings even after the cost of the 55 gallon steel drums used for compaction was subtracted.

Predictions are that this savings on drums coupled with the savings on burial and shipping costs will enable us to pay for our compaction program in less than two years. The total cost of the system including ventilation system and installation was \$10,670. A more far reaching savings may ultimately be reached because disposal of our low level radioactive waste requires minimal space at the burial sites.

## 7. CONCLUSION

Initiation of a waste compaction program has enabled us to keep pace with an ever increasing volume of radioactive waste being generated by clinical and research uses of radioisotopes at a new Medical Center. This program has provided us with savings in waste disposal costs as well as space required for waste handling and storage. The installation of a filtration system has eliminated the odor and airborne contamination problems which were generated through the compaction process.

1. Miller, K.L.: "A Radiation Safety Program for a New Medical Center," in Proceedings: Ninth Midyear Topical Symposium of the Health Physics Society, Denver, Colorado, U.S.A. February 9-12, 1976.
2. U.S. Nuclear Regulatory Commission, Rules and Regulations Title 10 Code of Federal Regulations, Part 20.



## EFFECTS FROM EFFLUENTS OF AN INCINERATOR FOR WASTE OF LOW LEVEL ACTIVITY IN THE ENVIRONMENT

E. NAGEL

Federal Institute for Reactor Research (EIR), Würenlingen  
Switzerland

1. In the incinerator for radioactive waste of the Federal Institute for Reactor Research the contents of 2230 barrels of 200 l have been burned from September 1975 to March 1976 within two periods of about 8 weeks each. The 44 tons of low level radioactive waste were of various origins (hospitals, industry, nuclear installations). The initial volume could be reduced to 45 barrels of 200 l. The following quantities of radioactivity have been released from the 25m high stack of the installation:

a) <u>Sept. 1<sup>st</sup> - Oct. 25<sup>th</sup> 1975</u>	b) <u>Febr. 2<sup>nd</sup> - March 28<sup>th</sup> 1976</u>
$\alpha + \gamma$ (Ci)      30,8 · 10 <sup>-3</sup>	10,2 · 10 <sup>-3</sup>
$\alpha$ (Ci)            4,2 · 10 <sup>-5</sup>	8,2 · 10 <sup>-5</sup>

For each period the incinerator was started with new ceramic filters.

2. The incinerator is situated near the northern fence of the Federal Institute (EIR, Fig.1) on the bottom of a broad valley; after this limit till to the woods (250m) surrounding the site of the institute there are cultivated fields with grass, clover and cereals. The first inhabited houses of the next villages are at a distance of about 1 km. The main wind directions are N-NE, S-SW and W; but during inversion situations and in general when local low winds prevail, all directions may occur.
3. Calculations have been made years ago to estimate the dilution of the effluents at the critical points of the environment, where the plume would reach the ground, but without taking in account the roughness of the ground which is of importance at this place (forest in N and E, buildings in S). All theoretical critical points were found to be situated too far from the source (adiabatic lapse rate: 400m, inversions: 1000 - 8000m). Visual (and partly olfactory) observations of the plume have shown that these points in reality must be placed nearer to the source for instance at maximal 200m from the stack during adiabatic lapse rate, i.e. within the area of the institute (S/SW) or over the cultivated fields (N/NE).
- In order to investigate the real effects of the incinerator in the environment, measures have been made during and after the incineration periods using the instruments already installed in the environment of the EIR for surveillance purposes (air sampler, collectors of sedimented dust). In addition samples of grass and barley have been taken and analysed.
4. The already installed net of dust collectors (covered with vaseline) has been completed at the end of the second period by 2 units which were placed in 200m distance SSW and NNE of the stack ("critical" points 4 and 5 on the map). So it has been possible to survey the effects of the effluents in the immediate and general environment of the facility. The filter of the air sampler has been analysed weekly, the vaseline of the collectors every two (or four) weeks.

Fig. 2 shows that in October 1975 the collected activity has also increa-

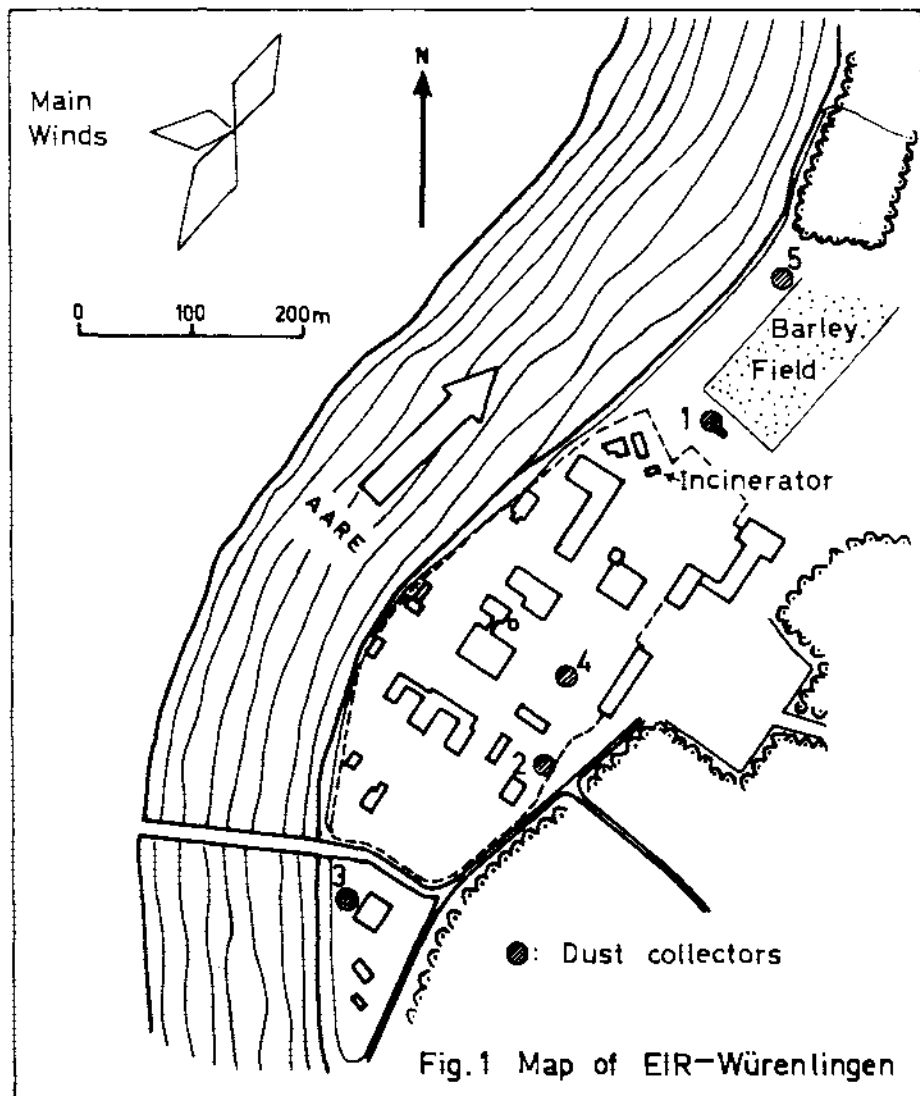

sed significantly in a location situated at 1,8 km distance from the stack. This village where the measure was made, is situated on the critical path of the winds from N/NE, which are frequent in the colder seasons and during inversions. The second location 2 km in the North has never been touched though it is also situated on a critical path, because in this country precipitations occur practically always with winds from S-SW and W.

On the filters of the air sampler an  $\alpha$ -activity of about  $0,001 \pm 50\% \text{ pCi/m}^3$  air was detected after each incineration period. After the first period it was not possible to detect a significant  $\alpha$ -activity on the dust collectors, but a few  $\text{pCi/m}^2$  Pu-239 and Po-210 could be identified on a grass sample collected in November 1975 at the location 1 (cf. map). During the second period an experiment was started at the beginning of February to investigate the retention capacity of the installation with respect to Pu-239. The analysis of the vaseline of the dust collectors at P 1, P 3 and of snow samples did not give significant results (about 2 pCi non-identifiable  $\alpha$ -activity on each sample).

After the incineration periods of the winter 75/76 it was interesting to know whether grass and barley growing in the neighbourhood of the installation had been influenced with regard to their activity content by the deposited radionuclides. It is to be remembered that the main growth period of vegetation takes place from April to June and that these crops are harvested in May (grass) and in June (barley).

The first grass samples were collected on April 30th at P 1, P 4 and P 5. The  $\beta$ -activity of all 3 samples is similar, i.e.

$$300 \pm 20 \text{ pCi/g ash};$$

these values are practically the same as those found in summer 1975 at the same location ( $280 \pm 15 \text{ pCi/g ash}$ ). The samples contained all three of the radionuclides already identified in the air dust, i.e. Cs-137, Cs-134 and Co-60.

Four weeks later, grass samples collected at P 1 did not contain more than  $130 \pm 20$  ( $\beta$ )  $\text{pCi/g ash}$  which corresponds to a normal K-40-content, and none of the radioisotopes found in the earlier samples could be identified.

Ripe barley collected near P 1 and P 5 at the end of June showed the following activity content:

	P 1	P 2
straw $\beta$ (tot)	$320 \pm 30 \text{ pCi/g ash}$	$340 \pm 30 \text{ pCi/g ash}$
K-40	$280 \pm 90 \text{ pCi/g ash}$	$280 \pm 90 \text{ pCi/g ash}$
Cs-137	( $\approx 4 \text{ pCi/g ash}$ )	( $\approx 4 \text{ pCi/g ash}$ )
grain $\beta$ (tot)	$190 \pm 30 \text{ pCi/g ash}$	$180 \pm 30 \text{ pCi/g ash}$
K-40	$160 \pm 60 \text{ pCi/g ash}$	$160 \pm 60 \text{ pCi/g ash}$
Cs-137	( $\approx 4 \text{ pCi/g ash}$ )	( $\approx 4 \text{ pCi/g ash}$ )

Most of the radioactivity originates from K-40; only traces of Cs-137 could be identified.

Neither in grass nor in barley significant quantities of Sr-90 or  $\alpha$ -emitters could be detected. It seems that most of the radionuclides deposited on the ground from September 1975 till April 1976 have been washed or blown off and have been "diluted" by the following rapid growth of vegetation.

5. In conclusion one can say that the effects due to the releases of the incinerator in the environment were very small. A first measurable contamination of the ground did not persist so that no biological cycles were involved. This result was obtained because incineration of waste did not take place during a period of great biological activity.

Fig. 2 B-Activity on dust collectors in the vicinity of EIR (pCi/m<sup>2</sup>)

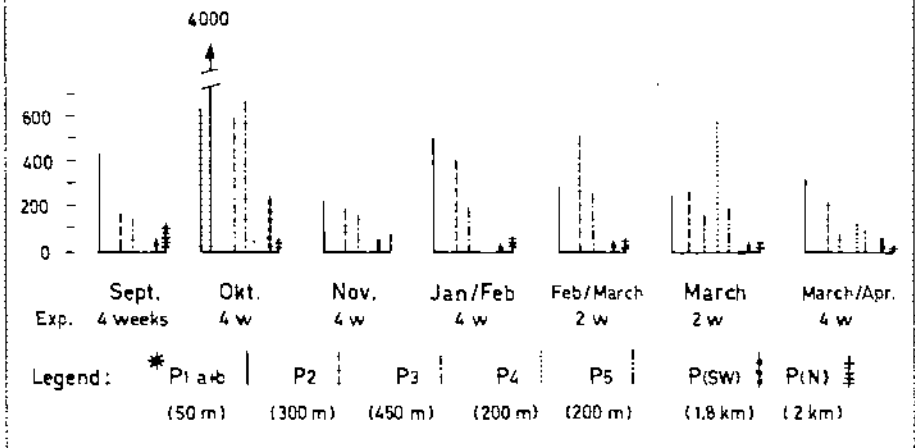

\*Of. map in Fig. 1; at P-3 there are 2 dust collectors (exposed during 2 resp. 4 weeks) and an air sampler.

One should remark the relatively high figure at P-1, collector b), of the same period as named before (October) which seems to have been due to "hot particle(s)" of Ce-144, an isotope which has not been identified on the other plates.

Obviously more dust and radioactivity have been deposited during the first period than within the second during which also 3 times less activity was expelled through the stack (cf. p. 1).

The geographical distribution of the deposited activity seems to show that fall-out (and rainout) scavenge the particles to the ground in the immediate neighbourhood of the stack. Only between March 5th - 19th, 1976 the main deposition occurred at a "critical" point 200m from the source (P 4).

Wind measurements on stack height have not been made during these periods; but observations showed that no exceptional weather situations occurred.

Significantly more activity was still deposited during 3 - 4 weeks following incineration. This release was due to dust and soot from the walls of the stack and the incinerator. Later the activity fell everywhere under 100 pCi/m<sup>2</sup>.

The following radionuclides could be identified in the vaseline by  $\gamma$ -spectrometry (Ge-Li-diode):

- 1<sup>st</sup> period: Ce-144, Cs-137, Cs-134, Co-60, Co-57, Rh/Ru-106
- 2<sup>nd</sup> period: Rn/Ru-106, Co-57, Co-60, Cs-137, Ir-192, Co-58, Cs-134

During the same time the air sampler showed also an increasing activity in the air; before and 4 weeks after the period of incineration 0,001 - 0,005 pCi/m<sup>3</sup> air were counted. During and shortly after the first period the figures climbed to 0,08 pCi/m<sup>3</sup>, in the second only to 0,02 pCi/m<sup>3</sup>. The radioisotopes on the filter were the same as those which have been identified on the dust collectors.

## LA DECONTAMINATION EN MILIEU GELIFIE OU COLLOÏDAL

Mme COURTAULT J., M. KOENIG J., M. LEBRUN J.C.

Centre d'Etudes Nucléaires de Saclay (CEN.S.)  
Service de Protection contre les Rayonnements (S.P.R.)  
Section d'Intervention, Décontamination et Stockage (S.IDS)

## SOMMAIRE

- 1 - INTRODUCTION : Intérêt du milieu gel en décontamination
- 2 - DEFINITION DU MILIEU "GEL"
- 3 - UTILISATION ET MISE EN OEUVRE
- 4 - ETUDE DES FACTEURS DE DECONTAMINATION
- 5 - CONCLUSION.

## 1 - INTRODUCTION :

L'élimination des éléments radioactifs fixés sur une surface polluée, fait appel à différentes méthodes mécaniques, physiques ou chimiques, engendrant elles-mêmes des déchets solides, des effluents liquides et des nuisances pour les opérateurs.

Les méthodes mécaniques ou abrasives modifient plus ou moins profondément les surfaces traitées et ne sont, par conséquent, pas adaptées à un matériel de précision.

Les méthodes physiques et chimiques, associées ou non, présentent l'inconvénient de produire des volumes importants d'effluents radioactifs qui devront être concentrés : c'est le cas des bains de trempage, des jets sous pression, des bains de polissage, des bains de dégraissage, etc...

La manutention des pièces à décontaminer peut présenter pour le personnel, des risques d'irradiation ou de contamination, ceci malgré l'utilisation d'installations appropriées.

Certaines décontaminations de locaux posent aussi de graves problèmes de sécurité d'approche.

Afin de réduire ces inconvénients et de diminuer les quantités de réactifs mises en jeu, nous avons pensé utiliser des mélanges décontaminants en milieu gélifié.

Ces composés-"support" seront, selon les circonstances :

- polymérisables et éliminés en déchets solides après arrachage,
- solubles dans l'eau et entraînés par un minimum de liquide de rinçage,
- pâteux, séchant facilement en donnant une poudre aspirable.

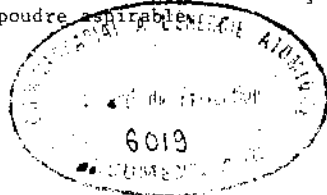

## 2 - DEFINITION D'UN MILIEU GEL

Un gel est une solution colloïdale dont les phases sont difficiles à définir, en raison du poids moléculaire du colloïde et de son état d'indivision important en solution.

Il convient donc d'introduire la notion de particule élémentaire du colloïde utilisé et de la définir aussi rigoureusement que possible :

- par les composants entrant en jeu et les réactions qu'ils engendrent dans les conditions de préparation,
- par la viscosité du milieu créé et la quantité de produit accroché à la surface,
- par le pH, la résistivité, la densité,
- par sa solubilité dans l'eau, sa compatibilité avec différentes solutions décontaminantes,
- par sa durée de séchage.

### 2.2 - Types de gels actuellement définis et utilisés en décontamination :

Les composés macromoléculaires organiques d'origine animale ou végétale présentent un cadre d'utilisation assez rigide en raison de leurs durées de conservation et de séchage qui sont difficiles à modifier.

Nous avons orienté nos recherches vers les composés macromoléculaires de synthèse plus stables et d'une plus grande souplesse d'utilisation. Les résultats présentés portent sur trois gels organiques et un gel minéral.

#### 2.2.1 - Gels organiques : Selon leur utilisation finale on distingue deux espèces de gels organiques :

a/ - Les gels miscibles et entraînaibles à l'eau et d'une durée de séchage très longue, qui peut être contrôlée par leur degré de polymérisation. C'est le cas des gels glycérophthaliques et glycérophosphoriques.

b/ - Les gels non solubles, totalement polymérisables, conduisant à un feuil arrachable ou à un enrobage assez solide et imperméable. C'est le cas d'un gel glycoacétate de cellulose.

#### 2.2.2 - Gels minéraux : Selon leur préparation on distingue deux espèces de gels minéraux :

a/ - Les gels modifiés par des additifs organiques. Ils sont presque aussi stables que les gels organiques mais possèdent des durées de séchage plus courtes. C'est le cas du silicate d'éthyle ou du silicoacétate d'éthyle.

b/ - Les gels non modifiés mais préparés en laboratoire. Ils sont sensibles aux variations de pH des milieux décontaminants, leur durée de séchage est assez courte et ils peuvent être aspirés sous forme de poudre. C'est le cas de l'alumine.

## 3 - UTILISATION ET MISE EN OEUVRE DES GELS EN DECONTAMINATION :

3.1 - Modes d'application : Tous ces gels peuvent être appliqués par projection au pistolet, par trempage et égouttage, au pinceau, dans des conditions bien définies. Les modes d'application sont dictés par les dimensions, les positions, les formes des surfaces à décontaminer. Ils déterminent la viscosité et l'adhérence du mélange à utiliser. Ces deux paramètres varient en fonction du degré de polymérisation du gel, de la composition chimique, du pH et de la résistivité du milieu décontaminant.

Il semble qu'un minimum de viscosité de 150 poises soit nécessaire à une application par projection pour une pression d'injection variant de 1 à 3 kg/cm<sup>2</sup>.

La répartition et les quantités accrochées sont, pour un même mélange, fonction de la distance buse-pièce et de la pression appliquée. Afin de déterminer la quantité et la composition de l'effluent formé on mesure la quantité d'eau nécessaire à l'élimination du produit déposé.

Un cas particulier d'application est celui du gel à base d'acétate de cellulose. Ce gel a été utilisé au cours du démantèlement de cellules contenant de l'américium-241 et du césium-137 sous forme pulvérulente. Répandu dans les poubelles de sortie, il a permis d'éviter, à ce jour, toute contamination atmosphérique, en fixant les aérosols radioactifs sur et dans le conteneur. Il ne présente pas d'inconvénient majeur pour le conditionnement de ces déchets dans les installations appropriées du Centre de Saclay.

3.2 - Des distillations fractionnées sont effectuées sur les mélanges gels/eau constituant les effluents à traiter.

Un certain nombre d'essais en laboratoire ont montré que ces effluents pouvaient être traités sans risque dans un évaporateur et qu'un traitement préalable n'était pas nécessaire.

#### 4 - ETUDE DES FACTEURS DE DECONTAMINATION :

Les essais effectués ont été réalisés dans deux directions et comparés chaque fois avec des essais effectués en milieu liquide.

4.1 - Dégraissage ou prédécontamination par application de détergents ou de composés en milieu gélifié : Les résultats sont exprimés en pouvoir dégraissant RD :  $RD = 100 \times \left( \frac{\text{Poids de graisse enlevé}}{\text{Poids de graisse déposée}} \right)$

Ils varient de 95 à 100 et sont comparables, pour les mêmes concentrations, aux résultats obtenus en milieu aqueux.

4.2 - Décontamination proprement dite : Cette opération est effectuée avec des décontaminants appropriés à certains radioéléments. On détermine le pouvoir décontaminant P.D. :  $P.D. = 100 \times \frac{\text{Activité avant} - \text{Activité après}}{\text{Activité avant}}$

Des résultats intéressants ont été obtenus avec des échantillons en acier inoxydable NSM 22 S provenant d'installations en service durant plusieurs années. Les radioéléments concernés sont le cobalt-60, le césium-137 et des petites quantités de plutonium-239. Ces résultats sont consignés dans le tableau ci-après.

#### 5 - CONCLUSION :

La méthode des gels a été appliquée, jusqu'à présent, à des pièces de petites et moyennes dimensions contaminées en utilisation. En plus de son efficacité, les bilans montrent que cette méthode est économique, tant en ce qui concerne les réactifs, le prix de revient du gel que le coût de la main d'oeuvre.

L'application de cette méthode a fait l'objet d'une demande de brevet.

#### BIBLIOGRAPHIE

- CHAMPETIER G. Introduction à la chimie macromoléculaire. Masson 1969
- DUCLAUX J. Colloïdes et gels. Gauthier-Villars 1953
- EITEL W. Silicate science. N Y Academic 1975
- MATIJEVIC E. Surface and colloïd science. Wiley Interscience NY1976

## Exemples de décontaminations de pièces d'acier inoxydable provenant du démontage d'installations

Origine de la pièce	N A T U R E S			Quantité en g/dm <sup>2</sup> de solution décontaminante fixée sur la surface à traiter	Quantité d'eau de rinçage en ml/dm <sup>2</sup> de surface traitée	Activité avant décontamination µCi/dm <sup>2</sup>	Activité après décontamination		% d'activité totale enlevée
	du milieu	du contaminant	du décontaminant				Après 1 h de contact	Après 2 h de contact	
LECI	Gel glycéro-phosphorique 84%	Césium 137	Acide chlorhydrique Chlorure stanneux	0,725	75	2,22	1,77	1,5	32,5
				0,825	54	3,33	2,16	1,77	46,7
				0,766	100	10,2	7,66	6	41
LECI	Gel glycéro-phtalique 84%	idem	idem	0,511	93	1,20	0,88	0,77	35,8
				0,433	98	1,30	1,02	0,99	23,8
				0,328	100	1,46	1,12	1,05	28,1
LECI	Gel silicate d'éthyle 84%	idem	idem	1,3	59	2,70	2,13	1,67	38,2
				1,7	50	2,17	1,64	1,47	32,2
				1,9	53	2,62	1,75	1,67	36,5
LECI	Solution aqueuse	idem	idem	100	100	1,30	1,14	1,01	22,3
						1,12	0,76	0,67	40,2
						1,24	0,84	0,81	23,9
Cellule CELIMENE	Gel glyco-acétate de cellulose 90%	Cobalt 60	oxine fluorure de sodium	1,8	Se décolle par humidification avant séchage (3 h)	0,027	0,015		43
				2		0,023	0,012	49	
Cellule CELIMENE	Gel glycéro-phtalique 90%	idem	idem	0,5	85	0,02	0,014		30
				0,4	85	0,02	0,015		25
Cellule CELIMENE	Gel glycéro-phosphorique	idem	idem	0,7	70	0,025	0,017		32
				0,7	70	0,013	0,005		61

Nota : Toutes ces pièces ont été préalablement décontaminées dans un bain sulfonitrique pendant 1 heure, la répétition de ce traitement n'entraîne pas plus de 10% de l'activité restante.



ROLE ESSENTIEL DU LABORATOIRE DE RADIOCHIMIE  
DANS LA CONDUITE DES TRAITEMENTS D'EFFLUENTS RADIOACTIFS LIQUIDES

CLUCHET J. - KOENIG R. - LECONNETABLE J. - EPISS J.

CENTRE D'ETUDES NUCLEAIRES DE SACLAY (CEN-S)  
SERVICE DE PROTECTION CONTRE LES RAYONNEMENTS (SPR)  
SECTION INTERVENTION, DECONTAMINATION, STOCKAGE (S. IBS)

## 1 - INTRODUCTION

La grande variété des effluents liquides produits par le Centre d'Etudes Nucléaires de Saclay, la dispersion des Unités productrices ainsi que les sévères restrictions de rejet dans l'environnement ont conduit à l'étude et à la réalisation d'une installation de traitement par évaporation. Les performances obtenues sont nettement supérieures à celles du traitement chimique précédemment utilisé. Enfin, l'enrobage par le bitume est plus satisfaisant que l'enrobage par le béton pratiqué jusqu'alors. L'installation a commencé à fonctionner en 1975. Nous allons la décrire brièvement et montrer ensuite le rôle primordial joué par le laboratoire qui lui est associé.

## 2 - DESCRIPTION DE L'INSTALLATION DE TRAITEMENT

2.1. Unité de traitement par évaporation : Cette unité amène l'effluent de faible activité (activité volumique inférieure à  $10^{-1}$  Ci/m<sup>3</sup>) d'une charge en sels de 1 g/l environ à un concentrat titrant 250 à 300 g/l. Son débit nominal est de 2 m<sup>3</sup>/h. Elle comprend deux faisceaux d'évaporation, une colonne de distillation à quatre plateaux et des équipements de récupération de chaleur (préchauffage de l'effluent par le distillat et récupération de la chaleur latente de condensation de la vapeur grâce à une compression de celle-ci).

2.2. Unité d'enrobage par le bitume des concentrats d'évaporation : A la fin d'une campagne d'évaporation, on transfère 2,5 m<sup>3</sup> de concentrat dans une cuve spéciale où l'on procède à un traitement d'insolubilisation. La solution traitée est ensuite envoyée dans un évaporateur à couche mince(1) où elle est mélangée à du bitume chaud (140 °C). Par effet centrifuge, le mélange est projeté sur une paroi chauffée à 240 °C. Le concentrat perd ainsi la quasi-totalité de son eau. L'enrobé bitumeux coule dans un fût métallique de 200 litres qui est fermé, après refroidissement, par un couvercle serti. Le déchet solide obtenu est dirigé vers le Centre National de Stockage (La Hague).

## 3 - TRAITEMENT DES EFFLUENTS - GENERALITES

3.1. Définitions : Le procédé peut être caractérisé par les deux quantités suivantes :

3.1.1. Facteur de décontamination (F.D.) : Pour un radionucléide donné, le facteur de décontamination est :

$$F.D. = \frac{\text{Activité totale initiale}}{\text{Activité totale rejetée par le distillat}}$$

3.1.2. Facteur de concentration (F.C.)<sup>\*</sup> : Le facteur de concentration du procédé est défini par le rapport :

$$F.C. = \frac{\text{Volume d'effluent traité}}{\text{Volume de déchets solides conditionnés}}$$

3.2. Objectifs à atteindre : Ils sont de deux ordres :

- Optimisation du facteur de décontamination, afin de diminuer le potentiel de pollution à rejeter
- stabilité du résidu solide obtenu

#### 4 - ROLE DU LABORATOIRE DANS LE TRAITEMENT DES EFFLUENTS

4.1. Analyses et essais préalables à l'évaporation : Avant le transport par camions-citernes, on procède à des mesures de débit de dose dans la cuve de stockage (choix du véhicule : blindage), puis à des mesures de pH et d'activités volumiques totales  $\alpha$  et  $\beta$  (sur résidu sec). Eventuellement, on procède à une spectrométrie  $\gamma$ . Ces mesures permettent de grouper les effluents par catégories (activité volumique et nature des radionucléides) en vue d'un traitement rationnel.

Puis, le laboratoire détermine les conditions de neutralisation de l'effluent à traiter (soude 12N ou acide nitrique 11N) qui doit avoir un pH voisin de 6,5.

Ensuite, on procède à un essai de distillation en vue d'observer la formation éventuelle de mousses et les variations de pH.

Enfin, on effectue des analyses chimiques et radiochimiques complètes, pour caractériser l'effluent à traiter :

Recherche et dosage de  $\text{Cl}^-$ ,  $\text{NO}_2^-$ ,  $\text{NO}_3^-$ ,  $\text{SO}_4^{--}$ ,  $\text{PO}_4^{---}$ ,  $\text{NH}_4^+$ ,  $\text{Ca}^{++}$ , Fe, mesure de la dureté, mesures de radioactivités  $\alpha$  et  $\beta$ , spectrométrie  $\gamma$ , dosage du tritium et du carbone 14 par scintillation liquide, enfin dosage du strontium 90 (2).

4.2. Contrôles du procédé : Au cours de l'évaporation, on prélève périodiquement des échantillons de distillat sur lesquels on procède à des analyses chimiques et radiochimiques pour contrôler la qualité de l'effluent à rejeter. En cas d'apparition d'activités anormales, des mesures sont prises immédiatement (stockage du distillat en vue d'un deuxième traitement, traitement chimique de l'effluent primaire, arrêt de l'installation, etc..)

Enfin, une analyse complète est effectuée sur la totalité du distillat qui est proposé au rejet. Le potentiel de pollution est exprimé en CMA.m<sup>3</sup>.

4.3. Analyses et contrôles préalables à l'enrobage : Le concentrat obtenu est amené à pH 8,5 puis, éventuellement, mélangé à des précipités de traitement chimique d'effluents de moyenne activité (activité volumique inférieure à 100 Ci/m<sup>3</sup>). On procède au traitement d'insolubilisation (sulfate de baryum et ferrocyanure de nickel) (3).

Avant d'entreprendre l'enrobage, on détermine la composition chimique et radiochimique du concentrat insolubilisé, sa charge en sels et sa densité (pour régler les débits de concentrat et de bitume dans l'enrobeur). Enfin, pour s'assurer qu'il n'y a pas de risque d'inflammation ou d'explosion, on procède à un essai de chauffage jusqu'à 400 °C d'un mélange bitume-concentrat. Eventuellement, cet essai est complété par une analyse thermique différentielle (4).

4.4. Contrôle de l'enrobé : Sur divers prélèvements d'enrobé, effectués au cours d'une campagne, on procède à des mesures de teneur en eau, de densité et de teneur en sels.

4.5. Analyses particulières : Ces analyses ont pour but de vérifier le bon fonctionnement de l'installation. Elles portent essentiellement sur les têtes de distillation, sur les distillats provenant de l'enrobeur, systématiquement renvoyés en tête du procédé, ainsi que sur le contrôle du bain acide utilisé pour éliminer les incrustations calcaires, entre les campagnes de distillation.

#### 5 - RESULTATS ESSENTIELS

5.1. Facteur de décontamination : Le facteur de décontamination varie avec les radionucléides présents dans les effluents. Les analyses effectuées tout au long des opérations permettent de suivre son évolution pour un cer-

tain nombre de polluants régulièrement rencontrés sur le Centre de Saclay (fig.1). On constate que ce facteur croît avec l'activité volumique initiale de l'effluent, elle-même sensiblement proportionnelle à la concentration pondérale des composés. D'un radionucléide à l'autre, on peut penser que les différences constatées dépendent pour une large part, de la forme chimique sous laquelle ils se trouvent au moment de la distillation.

De ce point de vue, il est intéressant de noter que le sélénium 75 et le carbone 14, généralement présents sous forme de molécules organiques, conduisent à des facteurs de décontamination nettement inférieurs à ceux des composés minéraux.

On est ainsi conduit à parfaire l'épuration par des traitements spécifiques, à différents stades du procédé. Par exemple, en ce qui concerne le sélénium 75, sous forme de sélénométhionine et divers composés organiques, on a mis au point une méthode d'oxydation par l'eau oxygénée, à pH 2 qui permet d'améliorer le facteur de décontamination. On peut également envisager une épuration au niveau des distillats (osmose inverse).

5.2. Evolution de l'activité volumique du distillat : On trouvera figure 2, deux exemples de courbes d'évolution de l'activité volumique  $C_1$  du distillat, en fonction de la charge en sels  $Q$  du concentrat. On constate que le palier observé dépend relativement peu de l'activité volumique initiale, ce qui explique l'allure des courbes de la figure 1.

Au début de l'opération (tête de distillation), l'activité volumique est voisine de celle de l'effluent primaire, mais décroît rapidement. En fin de traitement, on constate une légère augmentation de  $C_1$ , peut-être due à un entraînement mécanique, mais l'incidence de ce phénomène est faible sur le distillat à rejeter.

5.3. Caractéristiques de l'enrobé : L'ensemble des analyses effectuées sur le concentrat permet d'établir des fiches de caractéristiques de chaque fût d'enrobé, fiches communiquées à l'organisme de stockage. Lorsque l'appareil fonctionne correctement, la teneur en eau de l'enrobé est inférieure à 1%, ce qui lui confère d'excellentes qualités vis-à-vis de la lixiviation (5).

## 2 - CONCLUSIONS

A la lumière du bref exposé qui vient d'être fait, il apparaît que la mise en oeuvre du procédé et sa conduite dépendent étroitement des analyses de tous ordres effectuées par le laboratoire. Ceci est d'autant plus nécessaire que les effluents d'un Centre d'Etudes Nucléaires sont variés et peuvent poser des problèmes spécifiques. Le travail du laboratoire contribue très efficacement à la sûreté de l'exploitation, à la réduction du potentiel de contamination rejeté dans le milieu et à la qualité du déchet solide produit.

## BIBLIOGRAPHIE

- (1) LEFILLATRE G., RODIER J., HULLO R., CUDEL Y., RODI L. : Utilisation d'un évaporateur à couche mince pour l'enrobage par le bitume de concentrats radioactifs - Rapport CEA-R-3742, 1969.
- (2) CETAMA : Méthode n° 197 - 1966 - Comptage  $\beta$  sur le précipité d'oxalate de strontium après séparation de l'yttrium.
- (3) RODIER J., LEFILLATRE G., RODI L., CUDEL Y. : Enrobage des concentrats d'évaporation par le bitume - Rapport CEA-R-3632, 1968.
- (4) ROLLET A.P., BOVAZIZ H. : L'analyse thermique - Gauthier Villars Paris, 1972.
- (5) LEFILLATRE G. : Conditionnement dans le bitume des déchets radioactifs de faible et moyenne activité.  
Séminaire sur la bitumisation des effluents de faible et moyenne activité - Anvers (Belgique) 18-19 mai 1976.

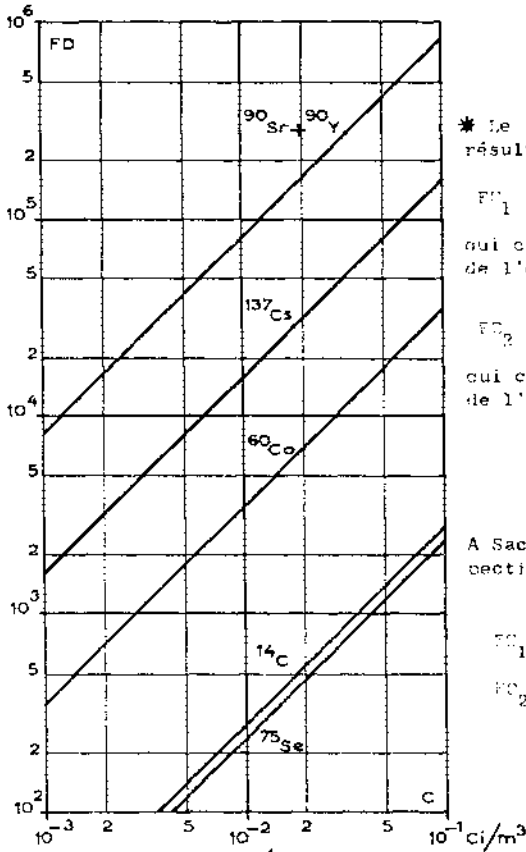

Fig. 1 - Facteur de décontamination FD en fonction de l'activité volumique  $C_0$

\* Le facteur de concentration F.C. résulte de deux facteurs partiels :

$$FC_1 = \frac{\text{Volume d'effluent traité}}{\text{Volume du concentrat}}$$

qui caractérise le fonctionnement de l'évaporateur.

$$FC_2 = \frac{\text{Volume du concentrat}}{\text{Volume du déchet solide final}}$$

qui caractérise le fonctionnement de l'enrobeur.

$$FC = FC_1 \cdot FC_2$$

A Saclay, les valeurs moyennes respectives de ces facteurs sont :

$$\left. \begin{array}{l} FC_1 \approx 80 \\ FC_2 \approx 1,3 \end{array} \right\} FC \approx 100$$

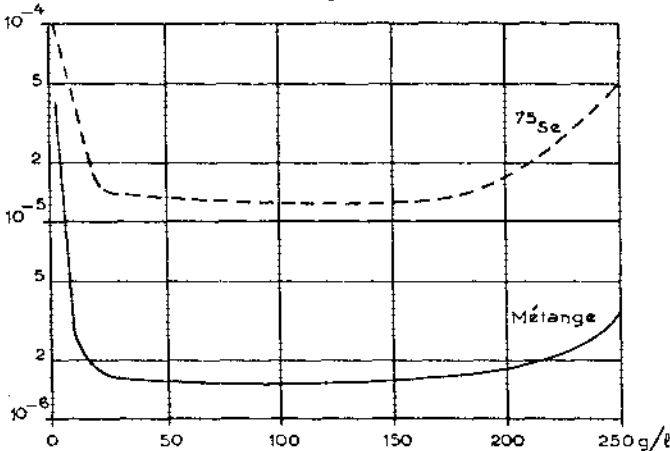

Fig. 2 - Evolution de l'activité volumique  $C_1$  du distillat en fonction de la charge en sels Q du concentrat

## THE RISKS AND BENEFITS TO MAN FROM ULTRAVIOLET RADIATION

K. Faber

The Finsen Laboratory, The Finsen Institute,  
Strandboulevarden 49, 2100 Copenhagen, Denmark.

In the field of radiation protection it is unique that the protection against the detrimental effect of a given radiation has to be balanced against an undoubtedly advantageous effect from the same radiation. The rule 'as low as readily achievable, economic and social considerations being taken into account' acquires a third dimension under these circumstances.

When you have to evaluate the effects of UV radiation this is the case and the balance between benefit and detriment has been of significant influence as long back as we can now visualize the history of biological life.

The earth is placed in an UV field from the sun which emits a continuous spectrum going from the far UV to the visible light. The biological effects of this spectrum, especially from the shortest wavelength are so severe that it is doubtful to what extent global life could be maintained if there was not a very efficient shield between the sun and earth. It is made up by the atmosphere by scatter in dust and fog and smog present but first of all by the atmospheric layer of ozone which absorbs the shortest wavelength to such an extent that no radiation at wavelength shorter than 288 nm reaches the earth.

A large part of the biological effects of UV depends on a specific absorption in DNA at a maximum at 265 nm. The resulting photochemical changes in the absorbing molecule: oxidation, interstrain linkage, Dimer formation etc. will more or less influence cellular division and viability. In order to survive most cells, bacterial to human have developed a set of repair mechanisms which react practically immediately to the irradiation and which after a reasonable time, in general less than 24 hours have brought the cell as close to normal as possible. It is however a process which has an upper limit in efficiency and which is furthermore error prone.

The acute effects of overexposure are the well known sunburn on the skin and photokeratitis in the eye. The dose relationship and the wavelength dependance is thoroughly studied and the well defined maximal exposure levels that have been set up can probably cover this field.

It is however the resultant late effects, somatic mutations and carcinogenesis that are made possible by the repair process which must be our preoccupation. Also cell death may be a result of greatest significance among unicellular organisms.

For man the carcinogenic effects are of greatest importance. Due to the specific absorption in the skin it is only under special circumstances that UV can produce tumors apart from here.

Three types may occur: the basal cell carcinoma, the squamous cell carcinoma and the malignant melanoma listed in increasing severity. In all cases there is experimental evidence in animals and reasonably good epidemiological evidence in man showing that UV is the most important inducing agent. Some points are significant in this connection: these tumors occur chiefly in areas of the body exposed to the sun during working hours, the incidence decreases with increasing pigmentation of the skin, and the incidence increases when the naturally occurring UV irradiation increases.

The cancer statistics are however not very good - too many skin tumors are treated without adequate histological control, but even so these tumors are common and will in Denmark represent 4.499 out of 39.573 tumors in male and 3.581 out of 41,488 in female in the 5 years period 1963 - 1967. Out of these 411 resp. 722 will be malignant melanomas. The curability of most of these tumors will on the other hand soften the picture although there has been a recent increase in malignant melanomas where the prognosis is still bad.

As a contrast to these serious effects of UV radiation it must be remembered that UV irradiation is necessary to give the photochemical production of the indispensable vitamin D<sub>3</sub> from 7-dehydrocholesterol.

Furthermore exposition to solar radiation in a not too high dose rate results in the well known general feeling of wellbeing. Finally it must be admitted that suntanning obtained by exposure primarily to UV gives a social and perhaps physiological addition to the wellbeing, at least of the less pigmented populations.

It will be evident that it is impossible to obtain this goal and at the same time avoid the detrimental effects under all circumstances. There is some difference in the evaluation of the relative importance of these two sets of events but there is so far no possibility for quantitative estimations and control.

The dose relationship in carcinogenesis should be the one most easy to evaluate. There is unfortunately not sufficient knowledge at present and confounding factors are such that they make the setting of a qualitative relationship difficult. I shall just mention the difference in pigmentation, the low UV exposure when living in large cities and biological factors such as the possibility of antibodies against f. inst. melanoma cells. The significance of clothing is large. The explanation for the increase in malignant melanoma on the legs of women seen in Denmark could for instance be the introduction of semitransparent nylon stockings resulting in a rise starting some 10 - 15 years later.

The benefits are even more difficult to evaluate, but if the relative high rate of rickets among Pakistani children in London can be taken as a sign of insufficient UV irradiation this can be an important public health problem. As far as I know only the USSR has drawn some concise conclusions by introducing low dose UV irradiation at the working places in the far north. Another exposure type can be seen in Denmark where since 1955 some 10% of the population each year moves into the mediterranean sunshine for vacation. This could be of influence for the increase in melanomas on the trunk that have been observed here and in Norway. This migration requires dosimetrical studies to study whether the carcinogenic action is in the first acute irradiation during the first

24 hours or how much later irradiation after start of pigmentation will mean in order to give advice in relation to possible protection.

I started this lecture mentioning the ozone layer over the earth. There is at present a widespread uneasiness about the fate of the ozone when it is disturbed by turbulence from supersonic aircraft or destroyed by chemicals as the fluorocarbons in sprays. Such effect would not only be of importance to man but could easily influence the whole biosphere on earth.

The significance and the fate of the UV field to which we are exposed is of interest to us all.

CURRENT VIEWS ON MECHANISMS OF INTERACTION OF MICROWAVE AND  
RADIOFREQUENCY RADIATION WITH LIVING SYSTEMS

Przenysław Czernski

National Research Institute of Mother and Child  
61-211 Warszawa, ul. Kasprzaka 17/a, Poland

1. INTRODUCTION

The mechanisms of interaction of microwave /MW/ and radiofrequency /RF/ radiation with living systems are still a controversial subject. The reason for this controversy is that available and generally accepted theoretical explanations are insufficient to explain all empirical observations. The limited space does not allow to present a detailed discussion of experimental data and theoretical approaches and the Reader is referred to the literature quoted for particulars. It should be pointed out that an excellent bibliography, containing over 3700 references, was prepared recently by Blaser /1/. Two symposia /2, 3/ and a recent critical review /4/ may serve as additional sources of information. Problems of extreme low frequency /ELF/ radiation effects were also subject of a symposium /5/.

To avoid misunderstandings the MW range is defined as electromagnetic radiation of 300 GHz to 300 MHz frequency, RF as 300 kHz to 0.1 MHz and the ELF as between 1 Hz and 100 Hz.

2. DEFINITION AND ANALYSIS OF MW- AND RF- BIOEFFECTS

A functioning living system /cell component, cell, organ, plant, animal/ is a highly complex, self-regulating system endowed with ability to adapt to changes in the environment, and to compensate for stresses imposed by it. The equilibrium of such a system is maintained by many interrelated feed-back mechanisms. Because of that the observed biological reaction may be many steps removed from the initial event. This is a particularly true for bioeffects induced by radiant energy. In view of that it is convenient to distinguish between primary interaction and bioeffects. These may be immediate - arising at the site of the primary interaction - and may induce early secondary effects at remote sites. In some instances a certain period of time may elapse between the primary interaction and the appearance of detectable bioeffects. In such a case these may be termed delayed or late effects. Elucidation of the chain of events leading to this or that biological effect and the determination of its relationship to the primary interaction necessitates an orderly step by step analysis. These use of adequate models, physiological and pharmacological methods is a prerequisite for such an analysis /6/. Adequate experimentation aimed at distinguishing between direct and secondary bioeffects may serve to explain apparent discrepancies between the theoretical explanations and empirical observations. On the other hand it may be used also for the exploration of basic biophysical and biochemical mechanism operative in the maintenance of biological functions.



### 3. THE PRIMARY INTERACTION

The mechanisms of radiant energy absorption and direct interference with biophysical, biochemical and bioelectrical phenomena in the living system, examined by biophysical methods and considered in terms of biophysics may be defined as the primary interaction. This was considered for many years almost exclusively in terms of the electromagnetic field theory, as developed and presented in detail by Schwan /7, 8/. It seems unnecessary to repeat all the arguments of this school of thought, as they are widely known. The principal conclusion was that, at least in the MW range, only conversion of the adsorbed electromagnetic energy into kinetic energy of molecules is possible. In other words the only mechanisms for the induction of MW bioeffects are consequences of thermal phenomena. These may of course change kinetics of biochemical reactions in the living system, particularly kinetics of enzyme reactions, inducing various local and generalized bioeffects.

The propagation and absorption of MW within the bioobject was approximated on the basis of planar, or at the best spherical, multilayered models and the blood circulation was considered as an inefficient system for distribution of the generated heat uniformly throughout the body /7, 8/. In consequence thermal MW effects in animals were considered "volume heating", a point of view unacceptable at present. Guy and his associates /9, 10/ developed elegant thermographic models and demonstrated clearly that the absorption of MW energy and the resulting temperature increases lead to nonuniform deep body heating. In physiological terms this means that direct, and even more secondary, MWBE depend on the internal distribution of the absorbed energy dose and local thermal stimulation of different organs. Local thermal stimulation of the brain and/or of the spinal cord /9/ affects many body functions and may be responsible for behavioral changes. As it was shown that at several MW frequencies energy absorption may be "focussed" around the center of the head /11/ and thermal stimulation of the midbrain section and of the hypophysics is a practical possibility during whole body exposures at about 1 mW/cm<sup>2</sup> incident power density of rabbits, cats, monkeys and men. The secretory activity of the hypophysics, an endocrine gland, regulates the activity of the remaining ones, such as adrenals and the thyroid. These in turn regulate the metabolic activity of many organs and tissues.

On the basis of simple energetic considerations it can be stated that the above "thermal" approach is insufficient to explain several empirical observations:

1. differences in bioeffects induced by pulsed or continuous microwaves of the same frequency and mean energy density,
2. frequency dependence of the induced bioeffects, which occurs both in the MW and ELF range.

As concerns point 1 it was demonstrated that different bioeffects, both qualitative and quantitative, are induced in the nervous systems and the hematopoietic system of animals exposed to 3 000 MHz radiation, dependent on the mode of generation pulsed or continuous - at same mean energy density /see 2 and 4/. Frequency dependence of effects on mitosis in bacterial and animal cells, as well as on colicin synthesis in *E. coli* were demonstrated by USSR authors /12/. Adey and coworkers demonstrated a frequency dependence of effects in the nervous system following exposure 147 MHz radiation, amplitude modulated at ELF frequencies between 8 and 20 Hz

/see 3/. The effects depend on the frequency of amplitude modulation. They appear to be most pronounced at 10-12 Hz and disappear at 16 Hz. Grodzny /see 3/ developed a very ingenious quantum mechanical explanation to account for this phenomena. This consisted in developing a quantized electrochemical concept of the greater neuronal membrane, comprising the neuronal phospholipid sheet of the cell membrane and the constituents of the intercellular spaces in brain tissue and serving as a physical substrate for electromagnetic field interaction with the nervous system. No explanation was offered for the frequency dependence of effects on mitosis and phage activation in bacteria /12/. It seems that quantum mechanical approaches may offer possibilities of explanation of MW and RF primary interaction with living systems. The concepts hitherto presented /see 2, 3, and 4/ should be considered as preliminary, they need further theoretical exploration and experimental verification.

#### REFERENCES

1. Glaser R.Z., Brown, P.F., Brown, M.S.: "Bibliography of reported biological phenomena /"effects"/ and clinical manifestations attributed to microwave and radio-frequency radiation: complication and integration of report and seven supplements" Naval Medical Research Institute, Bethesda Md 20814 1976. Obtainable from NTIS Springfield, Va 22151, USA
2. Czernski P., Ostrzewski K., Shore M.L., Silverman Ch., Sues M.J., Waldeskog B.:/ed/ "Biologic effects and health hazards of microwave radiation" Proceedings of an International Symposium, Warsaw 15-18 Oct 1973. Polish Medical Publishers, Warsaw 1974. Obtainable from Bureau Radiological Health, FDA, DHEW, Rockville, Md 20852, USA
3. Tyler P.E. /ed/ "Biologic effects of nonionizing radiation" Ann. N.Y. Acad. Sci vol. 247, 1975
4. Baranski S., Czernski P., "Biological effects of microwaves" Dowden, Hutchinson and Ross, Stroudsburg Pa, USA 1976
5. Persinger M.A. /ed/ "ELF and VLF electromagnetic field effects" Plenum Press, New York and London, 1974
6. Czernski P.: "Experimental methods for the evaluation of microwave biological effects" Proc. IEEE 63, 11, /1975/ 1540
7. Schwan H.P.: "Interaction of microwave and radiofrequency radiation with biological systems. IEEE Trans on Microwave Theory and Techniques, vol MTT 19, /1971/ 146
8. Schwan H.P.: "Principles of interaction of microwave fields at the cellular and molecular level. In/2/ page 152
9. Johnson C.C., Guy A.W.: "Nonionizing electromagnetic wave effects in biological materials and systems. Proc. IEEE 60, /1972/ 692
10. Guy A.W.: "Quantitation of induced electromagnetic field patterns in tissue and associated biologic effects. In/2/ page 203
11. Shapiro A.R., Lutomiński R.F., Yura H.T.: "Induced fields and heating within a cranial structure irradiated by an electromagnetic plane wave. IEEE Trans on Microwave Theory and Techniques, vol. MTT 19 /1971/ 187
12. "Scientific Session of the Division of General Physics and Astronomy, USSR Academy of Sciences" Abstracts in Soviet Physics Uspekhi 16, 4, /1974/ 568.

PRACTICAL EXPERIENCE ON MEASURING THE ELECTRIC  
COMPONENT OF THE EM FIELD IN THE GDR

EGGERT S., S. GOLTZ a. J. KUPFER

From the Central Institute of Industrial Medicine  
of the German Democratic Republic  
Director : OMR Prof.Dr. sc. med. R. G. Häublein  
1124 Berlin GDR Nöldnerstrasse 40 - 42

Comprehensive studies on the biological effect of high-frequency electromagnetic (EM) fields (60kHz - 300 MHz) upon the organism have induced competent institutions in the USSR, CSSR and the People's Republic of Poland in the sixties as well as in the GDR as from 1977 to stipulate MPL at working places for the electric and magnetic components of the electromagnetic field.

A near-field strength meter for measuring the EM radiation hazard at working places demonstrated by the authors has been designed in the Central Institute of Industrial Medicine of the German Democratic Republic. The battery-operated device is equipped with 2 dipole probes for measuring the electric field component. Within frequency range I ( $f = 60 \text{ kHz} - 30 \text{ MHz}$ ) the measuring range is  $3 - 2500 \text{ V/m}$ , within frequency range II ( $f = 10 - 350 \text{ MHz}$ ) it is  $1.5 - 1250 \text{ V/m}$ . The scale of the indicating instrument has been calibrated in  $\text{V/m}$ .

The meter outlined above can be completed by adding a probe for measuring the magnetic component of the electromagnetic field.

A method for calibrating this device, as well as some experience gained on its application in practice are reported on.

## THERMOLUMINESCENT DOSIMETERS FOR UV RADIATIONS

P. Bassi, G. Busuoli  
 CNEN, Laboratorio Fisica Sanitaria, Bologna, Italy

O. Rimondi  
 Istituto di Fisica, Università di Bologna, Italy

## ABSTRACT

Many radiological health agencies have stressed the necessity to develop portable, and possibly inexpensive UV radiation dosimeters for field measurements of the health hazard. This paper deals with a dosimeter based on the effect shown for the first time by the authors, i.e. the large enhancement of the intrinsic sensitivity to UV light of  $\text{CaF}_2:\text{Dy}$  (TLD-200) when treated at high temperatures. This detector is sensitive only to 250 nm wavelength; it can therefore be directly applied to the dosimetry of germicidal lamps. Similar sensitization techniques have been applied unsuccessfully to other TL materials. The intrinsic and transferred TL of the same materials have been measured as a function of wavelength, with results that seem to be useful for practical applications.

## 1. INTRODUCTION

It is well known that the usual TL detectors ( $\text{LiF}$ ,  $\text{CaF}_2:\text{Dy}$ , etc) preirradiated with gamma doses result sensitive to UV light (transferred TL). The preirradiation must be repeated before every exposure to UV.

We have shown(1) that a particular heat treatment sensitizes permanently  $\text{CaF}_2:\text{Dy}$  (TLD-200) to UV light. This characteristic makes it of practical use as UV dosimeter. Under well controlled experimental conditions the heat treatment has been standardized in order to obtain samples with reproducible responses. The sensitized TLD-200 is sensitive only to the wavelength  $\lambda = 2537 \text{ \AA}$  and therefore it is useful for the light emitted from a germicidal lamp but not for other sources with unknown spectral composition. Hence we have experimented both the intrinsic and transferred response of several TL detectors measuring their sensitivities to different wavelengths.

## 2. SENSITIZATION BY HEAT TREATMENT

$\text{CaF}_2:\text{Dy}$  (TLD-200) detectors are heated to  $900^\circ\text{C}$  within a tubular oven 150 mm long and 20 mm in diameter. The detectors are kept on a platinum tray placed at the center of the oven. A controlled air flow of 5 l/min circulates in the cavity. The heating lasts 15 minutes and then the detectors are let to cool in air at room temperature. In order to increase the sensitivity of TLD-200 to UV light, this treatment (following the same procedure) can be repeated up to a maximum of the order of 10 cycles (1). If the treatments are continued the sensitivity attenuates instead of increasing. The maximum sensitivity we obtained is about 500 times greater than the one of non sensitized TLD-200 detectors (2).

Following the outlined procedure we have also thermally treated  $\text{LiF}$  (TLD-100),  $\text{BeO}$  (Thermalox 995),  $\text{CaF}_2:\text{Mn}$  (TLD-400) under very different experimental conditions. The experimental results show that only TLD-200 can be sensitized.

### 3. RESPONSE VERSUS LIGHT WAVELENGTH

The TL detectors have been exposed to different wavelengths by using a high pressure Hg lamp coupled to a quartz prism monochromator with a resolution of the order of 10 nm. The irradiances at the different wavelengths have been measured with a thermopile radiometer that has a flat response over the whole range considered. The response of sensitized TLD-200 dosimeters versus wavelength is shown in fig.1. If we take into account the resolution power of the monochromator, the response curve (curve A) is practically a line at 250 nm. In the same figure the composite action spectrum for erythema and keratitis as reported by ACGIH is shown (3). As it can be seen, the sensitized TLD-200 is not a biological dosimeter for UV sources with a continuous spectral distribution. Fig.1 shows also that TLD-200 is insensitive to visible light. This is very important as in many practical situations the measurements are made in the presence of visible light.

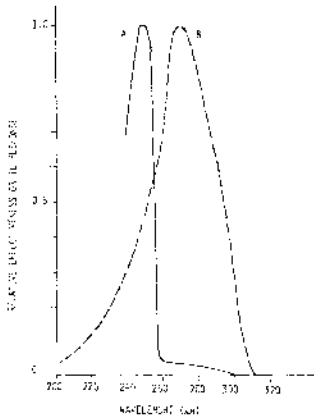

Fig. 1 - Response versus wavelength of sensitized  $\text{CaF}_2:\text{Dy}$  (curve A) and composite action spectrum for keratitis and erythema as proposed by ACGIH (curve B).

The transferred TL of the four detectors considered ( $\text{LiF}$ ,  $\text{CaF}_2:\text{Dy}$ ,  $\text{CaF}_2:\text{Mn}$  and  $\text{BeO}$ ) has been checked preirradiating them to a  $\text{Co-60}$  dose<sup>2</sup> of  $10 \text{ kR}^2$ , by partially annealing and exposing them to the same irradiance at different wavelengths in the range 240-600 nm. The response curves are continuous; Fig.2 shows the results obtained with  $\text{BeO}$  (Thermalox 995) and  $\text{CaF}_2:\text{Mn}$  (TLD-400).

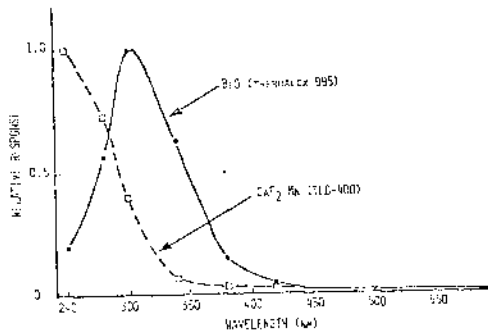

Fig. 2 - Transferred TL versus wavelength for  $\text{BeO}$  (Thermalox 995) and  $\text{CaF}_2:\text{Mn}$  (TLD-400).

The BeO response has a bell-shaped behaviour similar to the composite action spectrum shown previously but shifted towards higher wavelengths.

Fig. 3 shows the responses in the cases of LiF (TLD-100) and  $\text{CaF}_2:\text{Dy}$  (TLD-200). This latter presents a maximum at about 400 nm, while LiF is sensitive only to the light in the UV range.

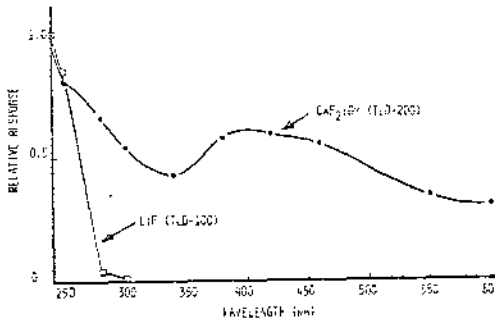

Fig. 3 - Transferred TL versus wavelength for  $\text{CaF}_2:\text{Dy}$ (TLD-200).

#### 4. REPRODUCIBILITY

The attention has been focused onto sensitized TLD-200. The following work has been aimed at characterizing sensitized TLD-200 for:

- the reproducibility of the sensitization procedures over different samples;
- the reproducibility of the same detector exposed to the same UV irradiance.

The sensitization procedure has been checked with five detectors separately and by accurately controlling the treatment conditions. After three sensitization steps of 15 min the different chips have been exposed to the same and known UV irradiance. The responses of the 5 detectors are roughly similar, but for precise measurements, the individual sensitivity factor has to be applied. Table 1, column 2, gives the sensitivity factors relative to the response of the first detector taken as 1.

Sample Number	Relative Sensitivity	Number of tests	Reproducibility
1	1.00	5	$\sigma = \pm 8\%$
2	1.69	5	$\sigma = \pm 6\%$
3	1.67	5	$\sigma = \pm 3\%$
4	1.03	5	$\sigma = \pm 5\%$
5	0.71	5	$\sigma = \pm 4\%$

TABLE 1 Sensitivity and reproducibility experimental data

The reproducibility of the same detector over repeated exposures is given in Table 1, for five successive irradiations. The reproducibility is in the range  $\pm 3\%$  to  $\pm 8\%$ . The reproducibility has been improved with respect to our previous experiments (4) by modifying the annealing procedure. The read-out process (max temp.  $400^{\circ}\text{C}$ , reading time 20 sec) has been, in fact, the only annealing applied, while the previous tests were performed by annealing the detector for 5 min at  $600^{\circ}\text{C}$ . Due to this relatively high temperature some influence on the detector sensitivity could be introduced.

Furthermore, as TLD-200 has a relatively strong short term fading, the overall accuracy of the measurements can be improved, for example by reading the detectors after a constant time is elapsed from the exposure.

#### 5. IRRADIANCE MEASUREMENTS

The irradiances of the UV beams have been measured with a radiometer (HP 8330/8334 A) that uses a thermopile as a sensitive element and that presents a flat response from UV to IR.

The calibration of the radiometer has been controlled with a NBS standard lamp model ET1 with a known irradiance at 1 meter (4).

#### ACKNOWLEDGEMENTS

The authors wish to thank Mr. V. Tadolini and Mr. A. Rinaldi who built the special devices used during the experimental tests.

#### REFERENCES

- (1) BASSI, P., BUSUOLI, G., RIMONDI, O., Health Phys. 31 2 (1976) 179
- (2) BASSI, P., BUSUOLI, G., RIMONDI, O. "Transferred and intrinsic thermoluminescence for UV dosimetry" Proc. 4th Int. Conf. Luminescence Dosimetry, Vol.3 (1974) 10/3
- (3) MATELSKI, I. "The non ionizing ultraviolet radiation" Paper presented at the American Hygiene Association Refresher Course N 24, May 21 (1973)
- (4) BASSI, P., BUSUOLI, G., RIMONDI, O. "A practical dosimeter for UV light" VII Int. Congress on Photobiology, August 29th-Sept. 3rd (1976).

## RADIATION LEAKAGE CONTROL OF A RADIOFREQUENCY INDUSTRIAL SYSTEM

M. Grandolfo and C. Raghiasci

Radiation Laboratory, Istituto Superiore di Sanità, Rome, Italy

During recent years there has been an increased development and use of equipments which can produce a number of types of non-ionizing electromagnetic radiation (NIR) which may be hazardous both to the user and to the general public unless necessary precautions are taken (1).

The NIR devices find an ever increasing use in industry, engineering, telecommunication, medicine, research, and in domestic life. This gave rise to public concern about their possible health hazards and stimulated large scale research programs (2). The Radiation Laboratory of "Istituto Superiore di Sanità" (ISS) has current national responsibilities and activities concerning the protection of public health from ionizing radiation exposures. The rapid proliferation of microwave and radiofrequency radiation sources during the last years and the wide differences in the reported values for safe exposure limits, stimulated even the evaluation of the health and occupational aspects of non ionizing radiation especially in relation to their industrial and medical uses.

Although microwaves are recognized as the type of NIR which represents the largest risk, increasing evidence has been reported on many biologic effects of low-frequency radiation (3). However, much less information are reported about situations involving this frequency range, although it is widely used in many industrial applications.

This paper reports preliminary results on the E-intensity pattern existing in the vicinity of a typical radiofrequency sputtering system, a relatively low power apparatus working at a frequency of 13.56 MHz and widely used in the electronics and computer industries and for scientific research purposes. An attempt is also made to compare these results, obtained in a near-zone situation, with the proposed safe exposure limits in the frequency range.

To evaluate occupational exposures, radio-frequency leakage intensity measurements were made at eye level in zones near the industrial unit where assisting personnel could receive an exposure in the normal course of their duties. Radiation leakage intensity measurements were made with the unit as close to normal operating conditions as was practical.

In the frequency band of interest, i. e. below 30 MHz, the potentially hazardous environments are generally within the near-zone region, where power density measurements cannot be made sensibly. To ensure that personnel is not unduly subjected to RF radiation in the HF band, a maximum permissible limit for continuous exposure in terms of the electric field intensity has been adopted. The reason for selecting electric intensity as the basis of safety assessment is that human tissue has the electrical characteristics of a lossy dielectric and is therefore particularly susceptible to the electric component of the RF field (4).

All measurements have been performed with a Field-strength meter



type HFH, produced by Ronde and Schwarz; the probes supplied with the set have small dimensions permitting accurate leakage measurements on transmitters or signal generators, near-zone field-strength measurements and measurements of field distribution in space. All measurements were made with an inductive probe, so insensitive to disturbances of the electric field by persons or objects present in the vicinity. Field-strength values were obtained in dB referred to  $1 \mu\text{V/m}$ , with an error of  $\pm 4$  dB.

We recall from basic physics (5) that in the region close to a periodically time varying electromagnetic source the Poynting vector will be complex and can be considered to indicate both real power flow and the reactive power flow present in the vicinity of the source, being the modal structure in this region not purely transverse (TEM) as in the far-field case.

Maxwell's equations show that when  $r$  is very much smaller than  $\lambda$ , as is the case of our primary interest, the  $(\lambda/r)^3$  term dominates and one properly refers to this region as the near-field region; in this zone an instrument that responds to the E field will measure the resultant of the vector addition of all field components, absorbing energy by a radiationless resonance energy transfer.

The results obtained along an axis perpendicular to the sputtering apparatus are shown in figure 1, for the two usual working power levels of 400 and 600 W. The  $R^{-3}$  dependence is quite well verified showing very clearly a typical near-zone situation in which only electrostatic component is dominant. We interpolated the experimental results by means of a Fortran IV minimization computer program, obtaining the dependence  $\log E = 4,474 - 3 \log R$  which gives rise to the expected  $R^{-3}$  law  $E(\text{V/m}) = 3.584 \cdot 10^4 / R^3 (\text{cm})$  for the 400 W emission.

The angular E-strength distribution has been also obtained, showing a pronounced peak at an angle of  $135^\circ$ , depending on the particular apparatus geometry. In figure 2 the results obtained at a fixed distance of  $10^0$  cm are shown; all the distances gave rise to similar patterns except for the E-strength values.

Second harmonics generation was also taken into account; E components for a frequency of 26.12 MHz were always present with values ranging in the order of 50% of those present for the fundamental frequency.

In the last years many investigations have been conducted on the biological action of continuously generated electromagnetic fields within the frequency range of 10-300 MHz, and concern has been aroused about the safety of personnel in intense RF fields such as that close to transmitting antennas operating in the frequency bands below 30 MHz (3). Unfortunately RF radiation standards are based on less biological data than microwave standards and further research seems to be necessary. However some of the radiation protection standards proposed in the USA cover also a part of the RF range leading to a maximum permissible limit of 200 V/m which is the electric intensity equivalent to a power density of  $10 \text{ mW/cm}^2$  under plane-wave (far field) conditions.

Specifically intended standards for RF radiation as defined by international agreements were introduced only in the USSR and Czechoslovakia and proposed in Poland (6). The USSR standard determines for electric field strengths in the range 100 kHz - 30 MHz a safe exposure limit of 20 V/m,

which is raised to 50 V/m in the Czechoslovakian standards. The Polish proposals are practically of the same order of magnitude as the USSR and Czechoslovakian ones. The divergences between USA and East European standards are, to a great degree, due to differences in basic philosophy, differences which appear in industrial hygiene and basic scientific research.

The East European maximum permissible exposure are mainly based on asthenia syndromes reported by workers in the radiation field, while the USA standards are based on the amount of exogenous heat which could be dissipated without resulting rise in body temperature (1).

From the numerical results shown in figure 1 and the maximum readings obtained following the field lines in the space surrounding the radiation source one can clearly conclude that it is now technically feasible to manufacture industrial RF sputtering systems, at least at relatively low power, with the proper maintenance and inspection, that will approach a leakage level no greater than 20 V/m (the more stringent reported safety limit) at a distance of 10 cm from any accessible surface. Many precautions, however, must be taken by preventing personnel from coming into close proximity to the device. In the case of sputtering systems the situation can actually occur when a visual control is to be maintained during the deposition of the sputtered films through the existing viewports.

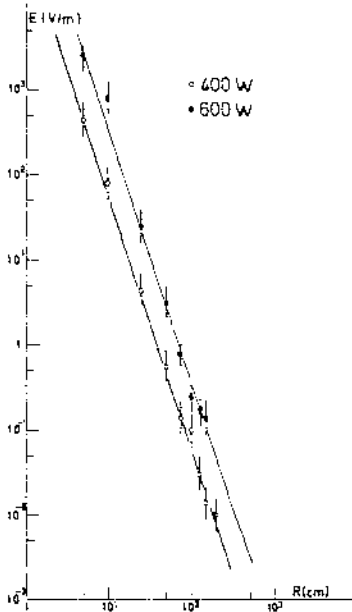

FIG 1

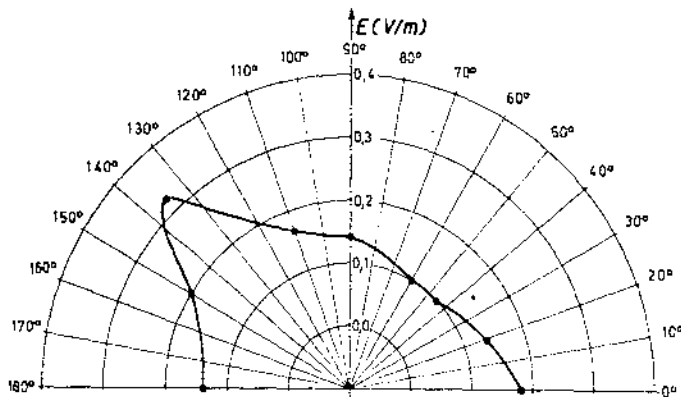

FIG 2

#### REFERENCES

- (1) MICHAELSON, S. M. , "Human Exposure to Nonionizing Radiant Energy-Potential Hazards and Safety Standards". Proc. of the IEEE, 60 (1972) 389-421.
- (2) SUESS, M. J. "The Development of a Long-Term Programme on non-ionizing Radiation Protection", Health Physics, 21, (1974) 514-521.
- (3) KALADA, T. V. , FUKOLOVA, P. P. and GONCAROVA, N. N. , "Biologic Effect of Radiation in the 30-300 MHz Range". Proc. of the Int. Symp. on Biologic Effects and Health Hazards of Microwave Radiation, Warsaw, October 1973.
- (4) ROGERS, S. J. , and KING, R. S. , "Radio Hazards in the m. f. /h. f. Band", Non-Ionizing Radiation, 1 (1970) 178-189.
- (5) ARMSTRONG, R. L. and KING, J. D. , "The Electromagnetic Interaction", Prentice Hall, New Jersey, (1973).
- (6) CZERSKI, P. , "Microwave and Radiofrequency Radiation Protection Standards Criteria", Report Submitted to the IRPA Study Group on Non-Ionizing Radiation Protection, Roma (1975). The Authors are very indebted to Prof. Czerski for many valuable discussions about this problem.

## NONIONIZING RADIATION EXPOSURE IN URBAN AREAS OF THE UNITED STATES

D.E. Janes, R.A. Tell, T.W. Athey, and N.N. Hankin  
Office of Radiation Programs  
U.S. Environmental Protection Agency  
9100 Brookville Road  
Silver Spring, Maryland 20910

## 1. INTRODUCTION

As part of a program to determine the need for environmental radio-frequency exposure standards, the U.S. Environmental Protection Agency began measuring radio-frequency radiation levels in urban areas of the United States in October 1975. Preliminary measurements indicate that transmissions in the broadcast bands are the principal sources of environmental radio-frequency radiation (1). Measurements were made in urban areas because sources are concentrated in and around regions of high population density (2,3). This paper describes the measurement system, typical environmental radio-frequency data, and one method of estimating population exposure.

## 2. MEASUREMENT SYSTEM

The measurement system consists of seven antennas, listed in Table 1, a scanning spectrum analyzer, and a minicomputer. The equipment is installed in a van equipped with gasoline powered electrical generators. Antennas are mounted sequentially on a pneumatically operated, telescoping mast and elevated 6.4 meters above ground level. After a predetermined number of scans through the desired frequency range, the data are corrected for antenna response and both the average root-mean-square values of the electric field strength and the power density obtained by integration of the squared field strength values are computed. The calculated values are displayed on the computer's cathode ray tube, copied onto thermally sensitive paper, and stored in the computer's memory. The measurement system, antenna calibration, and the analysis of system error are described in detail in reference (4). Examples of typical spectra can be found in references (4,5,6).

## 3. RESULTS

Measurements of environmental radio-frequency field strengths have been made at 72 sites located in Atlanta, Boston, Miami, or Philadelphia. The percent of sites having values equal to or less than a given total power density in the frequency range from 54- to 900-MHz are plotted against the logarithm of the power density on probability paper in Figure 1. Distributions for the land mobile bands, the low VHF-TV band, and the FM band are also shown. The power density values from the 0-2 MHz band are not included in this analysis and will be the subject of a later report.

The FM band contributes the most to environmental radio-frequency exposure between 54- and 900-MHz. Within this range of frequencies each of the three TV bands contributes about equally. The land mobile bands make an almost negligible contribution to the total power density and less active bands would make even smaller contributions. The maximum power

FREQUENCY (MHz)	USE	ANTENNA
0-2	VLF Communications and AM Standard Broadcast	Active Vertical Monopole
54-88	Low VHF Television Broadcast	Two Horizontal Orthogonal Dipoles
88-108	FM Broadcast	Three Orthogonal Dipoles
150-162	VHF Land Mobile	Vertical Coaxial Dipole
174-216	High VHF Television Broadcast	Two Horizontal Orthogonal Dipoles
450-470	UHF Land Mobile	Vertical Coaxial Dipole
470-806	UHF Television Broadcast	Horizontal Polarized Directional Log Periodic

TABLE 1 Antennas Used For Environmental Radio-Frequency Measurements

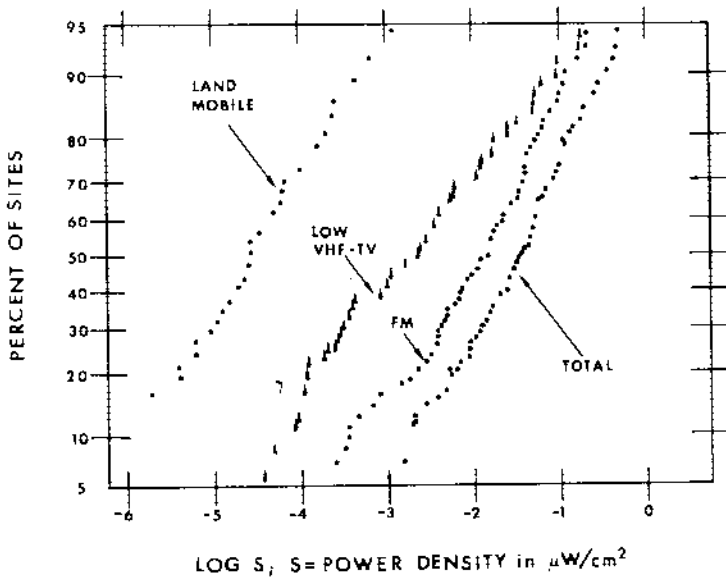

FIGURE 1 Distribution of Integral Power Density For The 54-900 MHz Band (total) And For Selected Bands In This Range

density at any site summed over all bands was  $2.5 \mu\text{W}/\text{cm}^2$ . Four sites or about 6 percent fell in the range of 1 to  $2.5 \mu\text{W}/\text{cm}^2$  so that some of the population is potentially exposed to values in excess of  $1 \mu\text{W}/\text{cm}^2$ .

### 3.1 Population Exposure

An estimator of population exposure must combine information on the distribution of radio-frequency levels with the distribution of population to provide numbers of people exposed at various levels. The population data base which was used here has been described elsewhere (6), but briefly, it consists of the population count for each of 250,000 census enumeration districts (CEDs) in the U.S. along with the geographic coordinates of the approximate population centroid for the CED. The population of an area is considered to be concentrated at a set of discrete points. The total power density from all sources at each of these discrete points is determined and the population exposed at the various levels is summed.

The model for determining the radio-frequency fields is based on data collected with the measurement system described above. The measured data from each source were observed to generally fall on a parabola when plotted as  $\log(\text{power density})$  versus  $\log(\text{distance})$ . Furthermore, the shape of this parabola was approximately the same for all sources, regardless of source parameters, differing from source to source primarily by an additive constant. Therefore, an empirical expression for the field strength, E, in dB above  $1 \mu\text{V}/\text{m}$ , as a function of  $\log D$  ( $D = \text{distance in miles}$ ), was chosen:

$$E = -10 (\log D)^2 - 20 \log D + C$$

where C is a source specific constant. To determine the field strength at any point (e.g., at a CED centroid) the three measurement sites nearest the point of interest are determined, and from the measured data at these three points, a value of the constant C for each source is determined. Substitution of the distance from the source to the point into the expression for E yields the required field strength estimate for that source. The individual source contributions can be appropriately summed to get the total exposure.

This approach was applied to each CED centroid in the four metropolitan areas where measurements had been made. The population for each CED was assigned the exposure determined for its centroid location. This information was sorted according to exposure ranges, and the results are presented in Figure 2 which shows the fraction of the population in the four metropolitan areas (total population = 8.3 million) exposed to various levels. The median power density is  $0.014 \mu\text{W}/\text{cm}^2$ . Less than one percent of the population is exposed to values greater than  $1 \mu\text{W}/\text{cm}^2$ .

This model for population exposure does not account for complications such as daily movements of the population within an area, exposures at heights greater than 6 meters where exposures can be higher due to non-uniform antenna radiation patterns, for any attenuation effects of typical buildings, or for times when sources are not transmitting. The results are simply the population residing in areas where an unobstructed measurement 6 meters above ground would result in the indicated values.

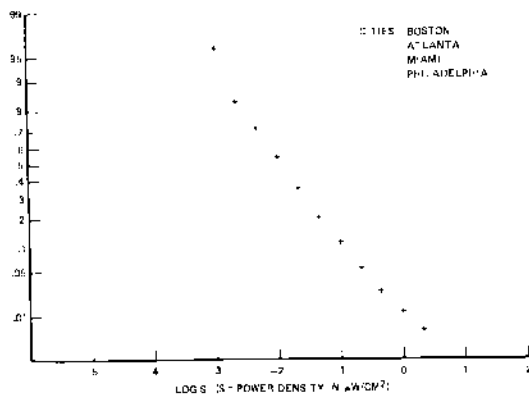

FIGURE 2 Fraction Of Population Exposed At Various Power Densities

#### REFERENCES

- (1) TELL, R.A., NELSON, J.C., HANKIN, N.N. "HF spectral activity in the Washington, DC area", Radiation Data and Reports 15 9 (1974) 549
- (2) MILLS, W.A., TELL, R.A., JANES, D.E., HODGE, D.M. "Nonionizing radiation in the environment", pp 200-211, New Horizons, Proceedings of the 3rd Annual Conference on Radiation Control, US DHEW Publication (FDA) 72-8021, Rockville, MD (1971)
- (3) TELL, R.A. "Environmental nonionizing radiation exposure: a preliminary analyses of the problem and continuing work within EPA", pp 48-68, Environmental Exposure to Nonionizing Radiation, US EPA Publication EPA/DRP 73-2, Washington, DC (1973)
- (4) TELL, R.A., HANKIN, N.N., NELSON, J.C., ATHEY, T.W., JANES, D.E. "An automated measurement system for determining environmental radio-frequency field intensities, II", pp 203-213, Measurements for the Safe Use of Radiation (FIVOZINSKY, S.P., Ed.), National Bureau of Standards Special Publication 456, Washington, DC (1976)
- (5) TELL, R.A., JANES, D.E. "Broadcast radiation: a second look", Biologic Effects of Electromagnetic Waves (JOHNSON, C.C., SHORE, M.L., Eds.), US DHEW Publication (in press)
- (6) JANES, D.E., TELL, R.A., ATHEY, T.W., HANKIN, N.N. "Radio-frequency radiation levels in urban areas", Special Supplement in biology to Radio Science (GUY, A.W., JUSTESEN, D.R., Eds.) SS-1 (1977) in press
- (7) ATHEY, T.W., TELL, R.A., JANES, D.E. "The use of an automated population data base in population exposure calculations", pp 29-36, Proceedings of the Health Physics Society Eighth Midyear Topical Symposium (HART, J.C., RITCHIE, R.H., VARNADORE, B.S., Eds.) US AEC Technical Report CONF-741018, Oak Ridge, TN (1974)

MUTAGENIC ACTION OF NON IONIZING RADIATIONS:  
ITS IMPLICATION IN RADIATION PROTECTION

U. Madhvanath, P. Subrahmanyam, N. Sankaranarayanan and D.R. Singh  
Division of Radiological Protection  
Bhabha Atomic Research Centre  
Bombay 400 085, India

## 1. INTRODUCTION

Biologic effects of non-ionizing radiations(NIR), mainly microwaves and ultrasonics, has been the topic of two international meetings in 1974(1,2) and several aspects at cellular and organism level were covered which gave insight into the mechanism of action of NIR on biological systems. Whereas the lethal, mutagenic and carcinogenic effects of UV, near UV and even visible light are known, mutagenic action, if any, of microwave radiation is just not known. Further, mutation is brought about by a sub-lethal damage in the DNA molecule of a cell which gets expressed as the cell progresses through its duplication and this end point is independent of slight temperature variations normally encountered in microwave absorption at low fields. Thus, we have yet another method to prove the existence or not of athermal effects of microwaves. Reversion to prototrophy of a diploid mutant strain of yeast following exposure to a wide spectrum of EM radiation (from cobalt-60 gamma rays to 2450 MHz microwaves) was studied and results are presented.

## 2. MATERIALS AND METHODS

### 2.1 Radiation Sources and Dosimetry

Irradiations in the UV (254 nm), near UV (313 nm, 365 nm) and the visible region (480 nm) were carried out in an Aminco-Bowman spectro-photofluorimeter. Energy fluxes incident on the quartz sample holder were determined by actinometry with potassium ferrioxalate system at 254 nm and determining the relative intensities at other wavelengths by the method of rhodamine B in propylal-glycol. The flux values obtained were 1.9 (for 254 nm), 5.8 (for 313 nm), 6.6(for 365 nm)and 9.7 for 480 nm, all in  $10^8$  erg/sq. cm/min. In order to determine the absorbed energy by the cell suspensions, optical densities ( $10^7$  cells/ml and 1 cm path length) were measured using a Cary 14 Spectrophotometer. It was 0.23 at 254 nm and about 0.16 at other wavelengths.

A neodymium (Nd) solid state pulsating Laser beam (1.01  $\mu$ m) was obtained with a laboratory built set-up with filter and lens arranged such that the beam spot at the irradiation plane was of 1.2 cm diameter. Pulse duration was 30  $\mu$ s and the energy fluence, as measured with a Hadron Model 102C Energy/power meter, was 3.4 J/pulse. For microwave irradiations, a laboratory built 0-200 W equipment at 2450 MHz was used. A 9.4 cm dia. hemispherical horn antenna gave a close field level of 2W/sq. cm at 1.7 cm from the face of the horn for 160 W power level. For low field irradiation, a distance of 14.3 cm was used which gave 25 mW/sq. cm at 60 W power



level. A Narda Model B86B3 Radiation Monitor together with a locally built instrument was used to measure these fields. For ionizing radiation, a cobalt-60 Gamma Cell with an exposure rate of 1.8 kR/min. was used.

## 2.2 Yeast Culture and Sample Preparation for Irradiation

A diploid yeast strain BZ34 which requires arginine for its growth was used. Exposure to radiation can induce reversion to arginine-independence by the process of intragenic recombination. These recombinants can be detected by plating the irradiated cells on a medium lacking arginine. Details of culture growth and media are given elsewhere(3). Following exposure, YEPD agar plates were used to determine surviving cells and Arg<sup>-</sup> plates to detect radiation induced revertants. A suspension of 10<sup>7</sup> cells/ml in sterile water was chosen for all irradiations with gamma, UV, near UV and visible light irradiations. All irradiations were carried out at room temperature (21 to 24°C) although cell suspensions were stored at about 5 to 10°C until they are taken out for irradiation.

For laser beam irradiations, 2.5 x 10<sup>8</sup> cells were collected on a 1 cm dia. area of a millipore filter paper by filtering and this paper positioned inside a plastic petri dish was exposed to the horizontal beam. Samples received energy pulses of 2.4 J/pulse at two rates namely (i) at 5s intervals and (ii) at 60s intervals. Following exposure, the cells were re-suspended in water, diluted appropriately and plated. For microwave irradiations, 16 ml of 10<sup>7</sup> cells/ml suspensions was taken in 5 cm dia. plastic petri dishes and positioned vertically below the horn. As the small-tipped thermister probe (of a locally built Clinical Thermometer instrument) could not be used to continuously monitor the temperature rise during irradiation (due to interference by EM field), measurements were made within seconds following the termination of exposure.

## 3. RESULTS AND DISCUSSION

### 3.1 Gamma, UV, near UV and visible light radiations

Fig.1 shows the pooled results of several experiments plotted as the number of induced revertants per million survivors vs irradiation time. No killing of cells was observed for 313, 365, and 480 nm radiations for the exposure range studied and the survival for UV(254 nm) and gamma ray exposures (6 min. & 6 krad) were 90 and 95% respectively. Actually no increase in the reversion frequency was observed for 480 nm radiation (60 min); the experimental points on the fig. were those of samples suspended in 10<sup>-3</sup>M of ethidium bromide (EB), a chemical which binds to DNA and has an absorption maximum at orange region. Energy absorbed scales are also shown in the fig. for these radiations computed using the optical densities of cell suspensions and irradiated area (4 mm x 5 mm, and 2 ml sample). From the slopes of the lines in the figure, intrinsic efficiency of different radiations were calculated in absorbed energy, erg/cell and given in Table 1. Yeast cell mass of 1.4 x 10<sup>-10</sup> g was used to get the value for absorbed gamma energy.

It can be seen that the reversion induction efficiency of UV radiation has decreased by 5 orders of magnitude when compared to ionizing radiations and further decreased by 2 to 3 orders while reaching the black radiation (365 nm). Visible region is not mutagenic.

### 3.2. Nd Infrared Laser Beam

Fooled results of two experiments are given in Table 2. For exposure to short pulse intervals (5s), 50% of the cells were killed at 48J/sq. cm fluence. But no increase in the reversion frequency was observed. With longer pulse intervals (60s), even killing was negligible for the highest fluence given (120J/sq. cm) indicating large dependence of exposure rate on lethal effect. Like the visible light, this laser is also not mutagenic.

### 3.3. Microwave Radiation (2450 MHz)

Table 3 summarises the results of the microwave irradiations, exposed both at close and far field positions (acute and chronic exposures). It can be seen that even when the cell temperature is raised to 55°C at which only 37% of cells survived, there was no increase in the reversion frequency, thus clearly demonstrating the non-mutagenic nature of microwaves. Chronically exposed sample did not show even killing leading to the conclusion that the thermal effects are responsible for the lethal effects observed. Thus with sufficient energy densities of microwave fields, only killing of cells is possible and no subtle damage can be caused to DNA to bring about a mutation. This conclusion was predicted by Cleary (4) on theoretical grounds 4 years ago.

### IMPLICATION OF THE RESULTS TO RADIATION PROTECTION

Present results indicated that mutagenic action of NIR exists from very low wavelengths to visible light region up to about 450 nm, but quantitation of this effect needs to be made with mammalian cells (either in vivo or in vitro) to have any meaning for evaluating hazards to man. Induction of skin tumors in hairless mice following exposure to 313 nm UV radiation (5) was an investigation in the right direction. As regards wavelengths higher than the visible region (infrared, lasers, radars and microwaves), present results indicate that this region of NIR is not mutagenic and at best, as observed by Webb (6), particularly with extremely high frequency microwaves (80 to 140 GHz), alterations in the metabolic functions of mammalian cells, such as the inhibition of protein or other macromolecular synthesis, can be effected when exposed to weak fields. Thermal effects are only possible in most cases. Thus, the final analysis leads the protection standard setters for NIR, to leave the genetic apparatus of the single cell with its attendant somatic and genetic mutations, but concentrate on non-dividing organized tissue complexes whose functions are mediated by organelles other than chromosomes, for example membranes, and look for functional and pathological changes following exposure.

### REFERENCES

- (1) BIOLOGIC EFFECTS OF NONIONIZING RADIATION (TYLER, P. E. Ed). Annals of the New York Academy of Sciences, Vol. 247 (1975)
- (2) FUNDAMENTAL AND APPLIED ASPECTS OF NONIONIZING RADIATION (MICHAELSON, S. M., et al. Eds.), Plenum, New York (1975)
- (3) MURTHY, M. S. S., et al., Mutation Res. 27 (1975) 219
- (4) CLEARY, S. F., Health Phys. 25 (1973) 387
- (5) HSU, J., et al., Photochemistry and Photobiology 21 (1975) 185
- (6) WEBB, S. J., in Ref. (1) above, p 327-351

**Acknowledgements:** The authors are grateful to Ss. D. D. Bhawalkar and F. K. S. Rao for providing the laser and microwave apparatus respectively, to R. Rajagopalan, N. C. Pal for their help in dosimetry and to I. Das for assistance in laser experiments. We are also grateful to Dr. A. K. Ganguly for his encouragement and interest in this new area.

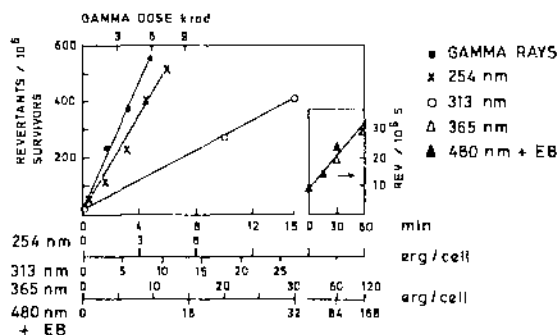

FIGURE 1. Variation of induced reversion frequency with exposure.

Gamma radiation	$1.54 \times 10^{-5}$	Black light (365 nm)	643
UV (254 nm)	0.92	Visible (480 nm)	--
Near UV (313 nm)	6.5	-- do -- + ethidium bromide	600

TABLE 1. Intrinsic efficiency of different radiations (in absorbed energy, erg/cell) to induce 100 revertants/ $10^6$  survivors.

Pulse interval 5s			Pulse intervals 60s		
Exposure J/sq. cm	% Sur.	Rev. / $10^6$ S	Exposure J/sq. cm	% Sur.	Rev. / $10^6$ S
0	100	23	0	100	8
24	87	20	48	94	9
48	50	23	120	97	8

TABLE 2. Survival and reversion frequency of yeast following exposure to laser beam at two pulse rates.

Irradiation conditions		irradiation time	Terminal temp	% Sur.	Rev. / $10^6$ S
<u>Acute</u>	Horn output 160W	0	24° C	100	14.0
	Field 2W/cm <sup>2</sup> at 1.7 cm	1 min.	55° C	37	14.3
<u>Chronic</u>	Horn output 60 W	0	22° C	100	19.0
	Field 25 mW/cm <sup>2</sup> at 14.3 cm	120 min.	no change	100	19.1

TABLE 3: Survival and Reversion frequency of yeast following exposure to microwaves.

## CONTROL OF NON-IONIZING RADIATION EMITTING DEVICES IN CANADA

Michael H. Repacholi, S.K. Ghosh  
D.A. Benwell and G.C. Dutt

Radiation Protection Bureau, Environmental Health Directorate  
Health Protection Branch, Health and Welfare Canada  
Ottawa, Canada K1A 1C1

During the past ten (10) years there has been a tremendous increase in the use of non-ionizing radiation (NIR) emitting devices. As such there has been an increasing need for controls on these NIR devices to ensure that they do not present a hazard to the users or the general public.

In Canada there is a fundamental division of responsibility in the health field. The Federal Government under the Radiation Emitting Devices (RED) Act draft regulations on design, construction and performance standards for new devices that are sold or imported into Canada. The Food and Drugs Act Medical Devices Regulations can also be used to draft performance standards for medical radiation emitting devices. Most of the Provinces of Canada have their own radiation safety acts that control the facility and the use of the NIR devices once they have been sold. Use of NIR devices in Federal establishments are controlled under the Canada Labour Code and Treasury Board Standards.

The Radiation Protection Bureau has been given the responsibility of determining potential hazards from NIR devices, proposing regulatory action as necessary, carrying out research into bioeffects of these radiations and developing radiation measurement techniques.

Control of NIR devices is divided up into three (3) general areas:

- (i) microwaves, RF and electromagnetic fields
- (ii) ultrasound and noise, and
- (iii) lasers, ultraviolet and other electro-optical radiations.

In each of these areas, surveys of NIR emitting devices are made. If potential hazards to device operators or risks to the general public are found, it is determined whether regulations will significantly reduce this potential hazard. If so, a detailed study of the design, construction and functioning of the device is carried out. With this information and other available standards and data from within and outside Canada, a draft standard is proposed in the Canada Gazette Part I.

Comments and criticisms are then solicited from manufacturers, users, professional associations, national and international standards organizations and other interested persons. These comments are then taken into account when drafting the final standard in the Canada Gazette Part II. Meetings with professional associations, manufacturer's organizations, technical experts and other Government Departments are held before the final regulations are published. After an appropriate lead-in time, all manufacturers must then construct their devices in accordance with the standards specified in the regulations.

Regulations for microwave ovens have been in effect since October 1974 and the responsibility for compliance to this regulation also rests with the Radiation Protection Bureau. To date over 130 models of microwave ovens have been tested and at present all of the ovens sold in Canada comply with the microwave leakage radiation requirements.

Extensive studies have been carried out on a number of other NIR devices, including demonstration lasers and laser scanners. A survey in Ottawa area schools indicated that some demonstration lasers were sufficiently powerful to produce eye damage quicker than the "blink" reflex to students who might inadvertently view the direct beam. Laser scanners are now becoming accepted by the big supermarket chains in Canada and our preliminary surveys indicated that potentially hazardous exposure to laser light of large fractions of the general public could exist if these devices were to proliferate without complying with appropriate safety standards. The final form regulations on these two types of lasers is expected to be published shortly.

Over sixty (60) NIR devices have been drawn up for possible regulatory control, so priorities for studying the hazard of these devices are assigned depending on the severity of their effect and the number of people exposed. Higher priorities have been given to the following devices:

- Ultrasound     -: diathermy, diagnostic and industrial cleaning devices
- Microwaves     -: diathermy, bloodwarmers, commercial communications devices and active metal detectors
- Ultraviolet    -: sun (health) lamps, dental polymerizers, mercury lamps and industrial sterilizers

Draft regulations on the above devices are at various preliminary stages.

In addition to drafting performance standards the Radiation Protection Bureau has compiled a number of safety codes under the Canada Labour Code and Treasury Board Standards. These safety codes basically outline how to use the devices in a safe manner, and what installation precautions are necessary to ensure that personnel exposures are kept within acceptable levels. Final form safety codes have been completed on:

- (i) open beam microwave devices
- (ii) closed cavity microwave devices
- (iii) active metal detectors, and
- (iv) demonstration lasers.

The safety code on active metal detectors was written in response to the tremendous increase in air-highjacking and the need to detect weapons on airline passengers. However there was the fear that passengers wearing cardiac pacemakers could suffer adverse effects when passing through these metal detectors. Setting up procedures to obtain the correct electric and magnetic field strength for these devices was written into the safety codes to minimize potential hazards to passengers wearing cardiac pacemakers.

General safety codes on open and closed microwave devices were developed to provide safety information on the increasing number of devices using microwave radiation. Radar control equipment at airports, communications devices, diathermy, door openers and bloodwarmers are among the current device applications of microwaves where these safety codes can be utilized.

Where possible, it has been the aim of the Radiation Protection Bureau to provide a safety code on use and installation together with a design, construction and functioning regulation on the NIR device. In this way a package of information covering all aspects of health and safety for the device are presented.

Since the non-ionizing radiation field is relatively young, bioeffect data pertinent to setting safe exposure levels is scarce. Part of the problem stems from the fact that the measuring instrument technology has not kept pace with demand. There is a great need for good portable survey instruments, especially in the ultrasound field. Since there are very few commercially available ultrasound measuring instruments, an ultrasound float radiometer, a balance radiometer and hydrophones have been developed at the Radiation Protection Bureau to assist in the surveys of ultrasound diathermy and diagnosis devices.

The Radiation Protection Bureau is presently involved in an ultrasound intercomparison study between a number of laboratories around the world, which hopefully will provide the basis for an internationally acceptable standard.

Investigations made at the Radiation Protection Bureau of ultrasound or microwave radiation on blood enzyme activity showed that no effect could be found when the temperature was held constant (1), (2) and (3). Criteria documents on the health effects of microwave radiation, noise and ultra-violet radiation are also being prepared. These documents are used as a basis for determining permissible exposure levels.

For the present, control of NIR devices must continue using maximum exposure levels determined from the best available data. Safety factors to these exposure levels may be necessary depending on the quantity and quality of data available. There is obviously a great need in the NIR field for internationally accepted maximum exposure levels similar to those produced for ionizing radiations by the International Commission on Radiological Protection (ICRP). Perhaps a similar organization for non-ionizing radiations should be formed to provide the same standard setting leadership as the ICRP.

#### Reference

- (1) M.L. Belkote, A.M. Muc and D.L. Johnson  
"Thermal and Athermal Effects of 2.8 GHz Microwaves on  
Three Human Serum Enzymes", J. Microwave Power 9 (1) (1974) 23
- (2) M.L. Belkote, D.L. Johnson and A.M. Muc  
"Thermal and Athermal Effects of Microwave Radiation on the Activity  
of Glucose - 6 - Phosphate Dehydrogenase in Human Blood",  
Health Physics 26 (1974) 45
- (3) M.L. Belkote, D.L. Johnson, J.W. Conner and R.G. Hussey  
"Effect of 3.6 MHz Ultrasound on Human Serum Proteins and Enzymes",  
Health and Welfare Canada, Radiation Protection Bureau Report IR-149  
(November 1974)

THE DISTRIBUTION OF COMMITTED DOSE EQUIVALENTS TO WORKERS  
EXPOSED TO TRITIUM IN THE LUMINISING INDUSTRY IN THE UNITED KINGDOM

Dr. J. Hipkin

National Radiological Protection Board,  
Northern Centre, Leeds, England.

## 1. INTRODUCTION AND METHODOLOGY

In the United Kingdom tritium has become almost the only radionuclide that is used in luminising. Two distinct methods of luminising are used, one involving the use of tritium gas and the other involving the use of luminous paint containing an organic tritium compound.

All the major luminisers have voluntarily taken part in urine monitoring programmes for their workers. The analyses have been carried out by the National Radiological Protection Board, and estimates of committed dose equivalents have been made from the results using previously published assumptions (1).

Committed dose equivalents below a level derived from three tenths of a maximum permissible dose equivalent have been reported as negligible in line with the recommendations of the International Commission on Radiological Protection (2). It has been shown that where annual dose equivalents reported according to this scheme are equal to, or greater than two rems the error introduced by this system is likely to be no greater than a few per cent (3). It was, therefore, decided to take annual aggregates of two rems or more, without correcting for the number of negligible reports. Where the annual dose equivalent aggregate was less than two rems an entirely different method was used. It centred on finding a relationship between the average of all the sample concentrations found for a particular person and the dose equivalent that that person should have been credited with. A relationship  $D = 0.085c$  describes the annual dose equivalent to the critical organs,  $D$  (rems) from a constant concentration  $c$  (nanocuries per millilitre) in body water. The viability of using this relationship to estimate annual dose equivalent was tested by using the data from people whose annual reported dose equivalents exceeded two rems. It was shown that the relationship gave a satisfactory fit.

## 2. ANALYSIS OF RESULTS

Only those persons for whom there was a reasonably good pattern of sampling throughout each of the years in question, have been included in the analysis. Of these only three persons were credited with dose equivalents in excess of five rems. The dose equivalent data was grouped into the following ten categories:

- |                        |                          |
|------------------------|--------------------------|
| 1) Less than 0.025 rem | 2) 0.025 rem to 0.05 rem |
| 3) 0.05 rem to 0.1 rem | 4) 0.1 rem to 0.2 rem    |
| 5) 0.2 rem to 0.5 rem  | 6) 0.5 rem to 1 rem      |
| 7) 1 rem to 2 rem      | 8) 2 rem to 4 rem        |
| 9) 4 rem to 6.5 rem    | 10) above 6.5 rem        |



The cumulative total, as a percentage of the total population, was computed for all dose equivalents less than, or equal to, the upper bound for each category. These were plotted on probability paper against the log of the upper bound dose equivalents. The plots are shown in the figures.

Because the distribution was seen to deviate from lognormality mean dose equivalents were calculated from the source data rather than from the log-normal statistical values and both are reported in Table 1.

Finally, for comparison, similar analyses were carried out for the rather smaller number of tritium users who work in the electronics industry. Their work involves the filling of electronic devices with tritium gas. Results are in table 1.

Presented in table 2 are the collective dose equivalents for the various groups of workers, calculated from the data in table 1.

### 3. DISCUSSION

Previous studies have concluded that dose equivalents based on film badge results are distributed according to a lognormal distribution (4). This study has shown that at least for low dose equivalents similar conclusions can be made about exposure to tritium. In this case, however, a deviation from lognormality has been detected. The upward trend in the lognormal plot at high dose equivalents indicates that there is less population in these categories than might be expected from a true lognormal distribution. There is a possible explanation for this. In cases where the concentrations for a particular person are reported to be higher than normal it is a typical response of the user to relieve that person of tritium work and employ him/her on other duties. Concentrations of tritium seen in subsequent urine samples are often seen to fall as the biological half-life would predict. It is easy to see why this form of dose management would be more so for internal exposure than for external. The response to a high urinary concentration may well be that the person has to be given time to reduce his/her body burden, whereas an external exposure is more likely to be considered to be a thing of the past. This is likely to result in a thinning out of populations in the higher dose categories.

Perhaps the most striking result that emerges from the analyses is that different kinds of use of tritium carry quite different risks of exposure. Gas luminisers clearly have a much greater risk of exposure than paint luminisers who in turn have a greater risk than workers in the electronics industry. There is a simple explanation for this. The annual turnover of tritium in gas luminising is some thousands of curies per year, whereas in the paint luminising industry it can only represent some tens of curies per year. Electronic users probably only use a few curies in a year at the most. The numbers of people employed are not vastly different between the different kinds of use so the trend is not unexpected.

### REFERENCES

- (1) STRADLING, G. N. Design and Implementation of Biological Monitoring Programmes for Tritium IN Assessment of Radioactive Contamination in Man, Proceedings Symposium, Stockholm, November 1971. Vienna, IAEA (1972).
- (2) International Commission on Radiological Protection, General Principles of Monitoring for Radiation Protection of Workers (Adopted May 24, 1968) Oxford, Pergamon Press, ICRP Publication 12 (1969).

- (3) HILKIN, J. An Assessment of the Accuracy of Reporting Committed Dose Equivalent for Exposure to Tritiated Water. To be Published.
- (4) SPECHT, R. P., BRODSKY, A. Log-normal Distributions of Occupational Exposure to Medical Personnel. Health Physics, pp 163-165, Volume 31 (Aug), Pergamon Press, (1976).

Worker group	No. of people	Year	Median dose equivalent (rems)	Geometric Standard deviation	Mean dose equivalent (rems)
All luminisers	136	1974	0.18	8.9	0.85
	146	1975	0.19	11.1	0.81
	129	1976	0.15	26.3	0.80
Paint luminisers	88	1974	0.08	6.3	0.33
	97	1975	0.08	14.1	0.42
	88	1976	0.09	21.4	0.49
Gas luminisers	48	1974	0.79	5	1.7
	49	1975	0.89	6.6	1.6
	41	1976	0.90	16.8	1.6
Electronics	83	1974-1976	0.02	4	0.05

TABLE 1. Statistical values for the exposure of tritium luminising workers in 1974, 1975 and 1976.

Worker group	Year	Collective Dose equivalent rems
All luminisers	1974	102
	1975	115
	1976	106
Paint luminisers	1974	29
	1975	41
	1976	43
Gas luminisers	1974	82
	1975	78
	1976	66
Electronics	1974-1976	1

TABLE 2. Collective Dose Equivalents

FIGURES

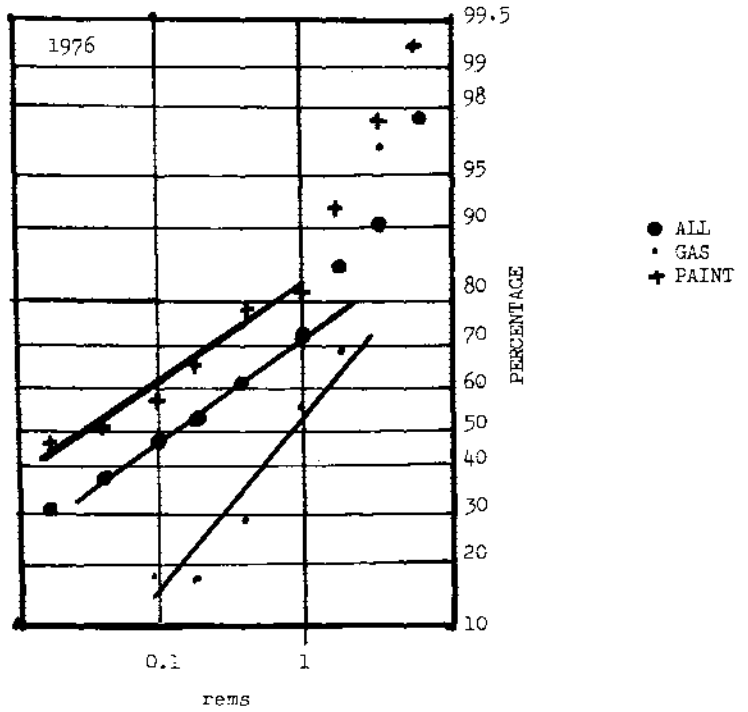
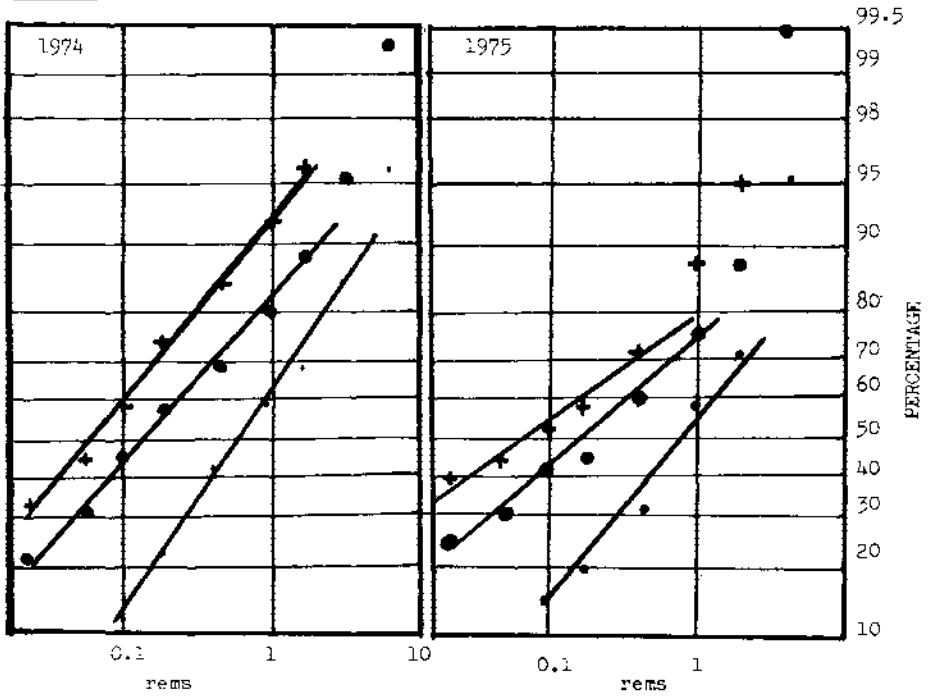

TRANSPORT WORKER RADIATION EXPOSURES  
HANDLING AIR SHIPMENTS OF RADIOACTIVE MATERIALS

F. J. Bradley, Ph.D., A. Jones and R. Kelly  
Radiological Health Unit  
Division of Safety and Health  
New York State Department of Labor  
Two World Trade Center  
New York, New York 10047

### 1. INTRODUCTION

The transport of radioactive materials is a complex operation involving many entities and requires for many radionuclides speedy transit. There is the consignor or shipper giving the package to a freight forwarder who in turn gives it to an airline carrier who transports the package in a timely fashion. At the receiving end the airline carrier gives the package to a freight forwarder who delivers the package to the ultimate consignee. There are variations of this flow with some consignors, consignees and airline carriers acting as their own freight forwarders.

This study (1) was undertaken to determine exposures to transport workers handling packages containing radioactive material (ram) at the Buffalo and Rochester area airports. Such workers are normally without any personal monitoring devices. Their exposure would be incidental to loading, unloading and sorting packages in cargo areas and processing the necessary paper work.

### 2. METHODOLOGY

For the purposes of this study all air carriers and freight forwarders located at the Buffalo and Rochester area airports were studied. A freight forwarder in the New York City was included in study because he did a great deal of containerization of ram packages for air transport. Each site was checked by radiation survey meter for external radiation, swears were taken on ram packages and in cargo areas where ram packages were handled and stored to detect presence of removable radioactive material contamination and finally all individuals who might be exposed to ionizing radiation were issued thermoluminescent dosimeter (TLD) badges; two types were available - one type to be worn on the body to determine the whole body dose issued to all individuals potentially exposed and the other a ring badge to be worn on the finger to determine hand exposure for those persons handling packages.

#### survey

For the package a seven consecutive day surveillance period was used at each airport. At each location whole body TLD (WB) badges were assigned to all personnel involved in handling and recording of packages including supervisors, dispatchers and handlers. TLD ring badges were assigned to handlers and other employees depending on duties. The normal badge wearing period was 6 - 8 weeks.

### 3. RESULTS

During the 7 day study period at Buffalo Airport 143 ram packages moved through the airline cargo areas. Of these 12 (9%) ram packages were exempt from labeling because they contained small quantities of radioactive material. The remaining labeled ram packages were distributed as follows:

57 (40%) packages Radioactive White I, 12 (9%) Radioactive Yellow II and 58 (41%) Radioactive Yellow III; the total observed TI handled during the 7 day period was 78.7 TI units while the labeled value was 111.9 TI units; assuming the 7 day study period was representative of most weeks in the year, the values extrapolate on an annual basis to 5819 (label) and 4092 (observed) TI units.

At the Rochester Airport 25 ram packages were moved through airport during the study period. These were distributed as follows:

15 (62%) Radioactive White I, 8 (33%) Radioactive Yellow II and 1 (4%) Radioactive Yellow III; during study period only 3.3 (label) 2.4 (obs) TI units were handled which extrapolates on an annual basis to 172 (label) 125 (obs) TI units, or only 3% of the value handled at Buffalo Airport.

At Buffalo Airport the predominant radionuclide based on TI was MoTc-99 with 37 (label), 25.1 (obs) TI units. The total activity handled was 190.0 Ci, contributed mainly by Ir-192, 164.0 Ci involving 2 separate shipments of 1 sealed source each - 112 Ci and 52 Ci, and MoTc-99 - 19.0 Ci. The corresponding TI units were Ir-192; 4 (label) 2.6 (obs) TI units; the other radionuclides contributing large TI units were Na-24: 13.4 (label) 14.3 (obs) TI units; I-131: 17.7 (label) 9.58 (obs) TI units; K-42: 12.8 (label) and 10.4 (obs). Na-24 and K-42 have half lives of 15 and 12 hours respectively and are produced at the University Reactor in the Buffalo Area and consequently these radionuclides are handled at Buffalo Airport with little decay. For Na-24 the TI (obs) was slightly higher than the TI (label) and for K-42 the TI (obs) was slightly lower. On the other hand for MoTc-99 the TI (obs) was only 68% of the TI (label) indicating considerable decay. The total activity handled on an annual basis at the Buffalo Airport and extrapolated from study period would be almost 10,000 Ci contributing 5800 (label) 4100 (obs) TI units.

The New York City freight forwarder who was included in the survey received ram packages from several radiopharmaceutical firms and forwarded them to all parts of the United States. To expedite this transfer the firm assembled groups of ram packages going to a given region into containers or overpacks. Based on the one day observation during which TLD area and personnel badges were distributed this firm handled 222 ram packages per week and 11,544 packages annually. The total TI handled per week would be 592 TI units (label) and 30,800 TI units (label) annually.

Ram packages were found in this study with few exceptions to be shipped in conformity with regulations. The major exception was a package with a surface dose rate greater than 300 mrem/hr and where upon opening by the shipper, it was found that the internal shield was left out. Packages and cargo areas were all essentially free of surface contamination.

Of the 41 transport workers who worked for the airlines at Buffalo Airport and who wore TLD badges for periods ranging from 6 to 8 weeks, two workers would receive 0.60 and 1.55 rem per year based on doses received during monitoring period. Nine would have received exposures between 0.25 to 0.5 rem/y based on monitoring period results. Out of 42 ring TLD badges issued only 28 were returned. Of these, two showed positive results which would indicate hand exposures of 0.24 and 6.01 rem/y. One individual who worked for AS which is both an air cargo carrier and freight forwarder had the

highest whole body and hand exposure 1.55 and 6.01 rem/y respectively. The cargo personnel working for the freight forwarders returned 52 TLD whole body badges, one worker would have received 0.67 rem/y based on the results of the monitoring period. Two whole body badges indicated that the wearers would have received 0.30 and 0.36 rem/y. Out of 67 ring badges issued 41 were returned and two indicated 0.31 and 0.42 rem/y hand exposure.

At the Rochester Airport, out of the 19 whole body and ring badges issued 11 whole body and 9 ring badges were analyzed and none gave any exposure above the minimum detectable.

At the New York City freight forwarder out of 17 whole badges issued 15 were returned from this firm and were worn for periods ranging from 31 to 63 working days. Of the 15 badges, 7 gave readings above minimum detectable and ranged from 0.24 to 1.69 rem/y. All but one badge was above the 0.5 rem/y. Of the transport workers who had positive whole body doses, the 3 who returned ring badges, had exposures of 0.71, 1.03 and 1.11 rem/y. The other 4 ring badges issued to workers with positive whole body dose were lost. Out of a total of 16 ring badges distributed only 8 were returned.

An estimate of the average population dose for the sample of workers who were monitored at each location is given by the following equation:

$$(PD) \text{ avg.} = \frac{\sum D_i}{\sum n_i} \times 250, \quad \frac{\text{man-rem}}{y}, \quad \text{where } \sum D_i \text{ is sum of doses received and } \sum n_i \text{ is sum of the days the badges were worn.}$$

Table 1 summarizes this calculation for each location.

#### 4. CONCLUSION

With the advent of sensitive TLD badges it is now possible to objectively determine whether additional radiation precautions are needed in a given operation.

Handling 5800 TI units (label)/y, Buffalo Airport transport workers had a population average dose value of 0.14 man-rem/y, within the 0.17 man-rem/y recommended. At 31,000 TI units (label)/y the sample definitely exceeded the population value. At 170 TI units (label)/y the population dose value was zero. One might draw the following conclusion: handling between 100-1000 TI units (label)/y probably will result in average and individual dose values within the recommended limits; between 1,000 to 10,000 TI units (label)/y, transport workers occasionally will exceed the recommended individual value but sample average dose value will be at or less than the recommended population dose limits; greater than 10,000 TI units (label)/y transport workers become radiation workers and should be monitored and inspected accordingly.

Location	Company	TI Handled	Average Population Dose	Average Annual Population Dose/TI
		$\frac{\text{TI units (label)}}{y}$	$\frac{\text{Man-rem}}{v}$	$\frac{\text{Man-rem}}{\text{TI}}$
Buffalo Airport Airlines	A1	2225.6	0.061	0.000027
	A2	504.4	0.032	0.000063
	A3	0	0.18	-
	A4	2006.8	0.16	0.000055
	A5	182	0.49	0.0027
	Totals	5818.8	0.14	0.000024
Buffalo Airport Freight Forwarder	D1	2116.4	0	0
	D4	1643.2	0.21	0.000128
	D5	0	0.046	-
	D7	0	0	-
	Totals	3759.6	0.021	0.000055
Rochester Airport Airlines	A1	20.8	0	0
	A2	0	0	-
	A4	93.6	No badges returned	-
	A5	57.2	0	-
	Totals	171.6	-	-
Rochester Airport Freight Forwarder	D5	0	-	-
	D7	26	-	-
	D10 & 11	140.4	0	0
	Totals	166.4	-	-
New York City Freight Forwarder	E6	30,800	0.36	0.000012

Table 1 Average Annual Population Dose Estimates

REFERENCE

1. This study was supported in part by a grant from the U.S. Nuclear Regulatory Commission and the U.S. Department of Transportation. This paper is based on material taken from the complete report submitted in December 1975 to these agencies.

## PERSONNEL MONITORING IN ISRAEL DURING 1975

M. Israeli, S. Malchi, Y. Feige, Y. Prulov, N. Rosental and A. Donagi  
Soreq Nuclear Research Centre  
Yavne, Israel

## 1. INTRODUCTION

Radiation workers in Israel are monitored by the Radiation Safety Dept. of SNRC, mainly by two means: (a) Exposures from external radiation sources are assessed by the Israel Film Badge Service (IFBS), and (b) internal exposures from ingested radionuclides are assessed by periodic urinalyses.

The IFBS supervises about 4000 radiation workers in the country. It does not include the radiation workers of the Negev Nuclear Research Center, which lately began its own personnel dosimetry service, based mainly on TLD. Dental practitioners and technicians who take less than 50 X-ray radiographs per day do not use radiation badges. Thus, most dentists and technicians are excluded from the IFBS.

The urine of about 600 workers who handle unsealed radiation sources is routinely checked for contamination. Urine samples are examined for traces of tritium,  $^{14}\text{C}$  and other  $\beta$ -emitters, and several  $\gamma$ -emitters. We generally encourage large centers working with tritium and  $^{14}\text{C}$  to institute their own routine urinalyses. So far only tritium and iodine contamination data are converted into internal doses, and added to the permanent dose record of the individual worker.

A shadow-shield whole body counter (WBC) is available for the rapid assessment of accidental contamination of workers by unsealed  $\gamma$ -emitting radionuclides.

## 2. THE ISRAEL FILM BADGE SERVICE (IFBS)

A single badge (Hanford type containing Kodak film type 2) is used for the evaluation of X-,  $\gamma$ -, thermal neutron and external beta radiations. The set of 8 filters in the badge permits determination of the effective energy of X-rays and discrimination between soft X-rays and external beta exposure. Another badge, containing Kodak film type A, is used for the dosimetry of fast neutrons. This method is based on proton recoil track counting.

The data presented here is derived from measurements of whole body exposures to penetrating X- and  $\gamma$ -radiations during 1975. Less than 200 workers are monitored for fast neutrons. The few recorded exposures to fast neutrons were insignificant compared to  $\gamma$  exposures in this group, and thus do not appear in the data.

Table 1 summarizes our results for the three main categories of radiation workers. The mean radiation dose of the occupationally exposed sub-population in Israel was about twice the natural background.

Table 2 compares the mean annual dose and the man-rad/year in these three categories for the years 1969, 1972 and 1975 (1). Over the 6 years, the mean annual dose increased in the medical field, and the total man-rad/year value was doubled.



A somewhat more interesting and meaningful way to examine our results is presented in Table 3 where the doses are averaged only among those workers who had at least one non-zero exposure during 1975. (As the FFBS is voluntary, a number of workers may subscribe to the service unnecessarily, while others who are receiving exposures may not be wearing film badges.) Table 3 shows that the mean dose is twice as high when workers with zero exposures are excluded from the statistics. It is interesting to note that while only about 15% of the workers in the Industry and Agriculture category receive any exposure, their mean exposure is relatively high.

### 3. INTERNAL EXPOSURES

A tabulation of 1062 urine samples obtained from 593 radiation workers who handle unsealed source is given in Table 4. 440 additional urine samples obtained from people who do not work with radioactive material were also analyzed and used as controls. These urinalyses revealed that internal contaminations were on the whole negligible, with a few exceptions for tritium and  $^{125}\text{I}$ .

Seven cases of tritium contamination occurred in 1975 during the production of light devices using gaseous tritium. Each contamination resulted in an exposure of about 400 to 600 mrad, derived by assuming that the ingestion of 1  $\mu\text{Ci}$   $^3\text{H}$  results in 170 mrad whole body exposure (2). There were about 10 additional cases where the internal exposure to  $^3\text{H}$  was between 0.1 and 25 mrad.

The production of  $^{125}\text{I}$  labelling kits for radioimmunoassay also involved 4 cases of relatively high intakes. The urine sample with the greatest contamination contained  $5 \times 10^{-3}$   $\mu\text{Ci}/\text{L}$  of  $^{125}\text{I}$ . Our subsequent investigations revealed that the  $^{125}\text{I}$  inhaled by these workers delivered 10 to 50 mrad/year to their thyroid glands. 1  $\mu\text{Ci}$   $^{125}\text{I}$  in the thyroid delivers a thyroid dose of about 780 mrad/week (3).

### ACKNOWLEDGEMENTS

The authors wish to thank R. Weingarten, Z. Karpiovitz, M. Surkes, A. Haik and other devoted technicians of the Radiation Safety Dept. for their technical assistance.

### REFERENCES

- (1) AVNI, A. and FEIGE, Y., Occupational exposure in Israel, Proc. of Jerusalem Regional Conf. on Radiation Protection, 1973, Vol. I, p.182.
- (2) ICRP Publication 10, p.30, Pergamon Press (1968)
- (3) GAVRON, A. and FEIGE, Y., Health Phys. 23 (1972) 431.

Category	No. of facilities	No. of radiation workers	Radiation workers % of population	Mean dose rad
Medical	203	1860	0.062	0.105
Industry & Agriculture	73	727	0.024	0.086
Research & Education	84	1393	0.046	0.030
TOTAL	360	3980	0.132	0.076

TABLE 1 IFBS Results for 1975

Category	1969		1972		1975	
	Mean dose rad	Man·rad/y	Mean dose rad	Man·rad/y	Mean dose rad	Man·rad/y
Medical	0.071	101	0.080	118	0.105	196
Industry & Agriculture	0.076	18	0.046	19	0.086	63
Research & Education	0.043	26	0.037	34	0.030	42
TOTAL	0.063	145	0.061	171	0.076	301

TABLE 2 Mean Occupational Exposure and Total Man·Rad/Year for 1969, 1972 and 1975

Category	No. of workers monitored	No. of exposed workers	Mean exposure of exposed workers rad
Medical	1860	806	0.243
Industry & Agriculture	727	94	0.666
Research & Education	1393	1023	0.041
TOTAL	3980	1923	0.156

TABLE 3 Non-Zero Occupational Exposure for 1975

Category	No. of radiation workers examined	Radionuclides tested for in urine							Total
		$^3\text{H}$	$^{14}\text{C}$	$^{32}\text{P}$	$^{35}\text{S}$	$^{125}\text{I}$	$^{131}\text{I}$	Other $\gamma$ -emitters	
Medical	122	31	17	3	0	69	47	27	194
Industry & Agriculture	154	89	51	2	0	58	0	27	227
Research & Education	317	194	125	86	15	68	3	150	641
TOTAL	593	314	193	91	15	195	50	204	1062

TABLE 4 Urinalyses of Radiation workers for 1975

En mettant sous presse nous avons appris avec tristesse le décès de M. Y. FEIGE. Cet éminent scientifique avait beaucoup contribué au développement de la Radioprotection.

THE NORTH RHINE - WESTPHALIAN FACTORY INSPECTORATE'S INCORPORATION MONITORING MEASURES FOR THE ROUTINE CONTROL OF POTENTIALLY ENDANGERED RADIATION WORKERS AND THE RESULTS OF THIS CONTROL COMPILED OVER THE PERIOD 1964-1976

H.R. Eriembach

Central Office for Safety Engineering, Radiological Protection and Nuclear Engineering, Factory Inspectorate of the State of North Rhine - Westphalia, Duesseldorf, Federal Republic of Germany

### 1. INTRODUCTION

As a result of the provision made by the Supreme Factory Inspection Authority of North Rhine - Westphalia (NW) for the precautionary regular incorporation monitoring of radiation workers who are considered to be potentially endangered because of their handling unsealed radioactive substances beyond specified radioactivity limits, three Incorporation Monitoring Centres (IMCs) for the obligatory incorporation surveillance of the radiation workers concerned are so far available in NW. These three laboratories are:

The Duesseldorf IMC, which was established by the Factory Inspectorate of NW in late 1963 in order to provide the public with an official IMC,

The Juelich IMC, which is the authorized incorporation control laboratory for the Juelich Nuclear Research Establishment, but also free to monitor radiation workers from elsewhere,

The Cologne IMC, which is officially authorized as well, but basically confines itself to monitoring persons affiliated to the Cologne university and refrains from excretion radioassay.

The extent of the obligatory incorporation surveillance for radiation workers is detailed in the ministerial order of July 24, 1968, promulgated in the Ministerial Gazette of the State of NW (1). At the present time, these guidelines are being discussed and revised in a committee at Federal level.

### 2. THE DUESSELDORF INCORPORATION MONITORING CENTRE AND ITS FINDINGS

The single-detector chair technique of Human Whole-Body Counting (HBC) employed at the Duesseldorf IMC and its performance is described elsewhere (2). The Liquid Scintillation Counting (LSC) of urine samples and the Fluorometric Urine Analysis for Uranium (FUU) are both standard methods. They need no further comment but the statement of the respective detection limits, which amount to less than 4 nCi/l for tritium and carbon-14 and 0.3 µg/l for uranium.

The Duesseldorf IMC's findings compiled over the period 1964-1976 are presented in the following tables 1-4, which are self-explanatory.

### 3. CONCLUSIONS DRAWN FROM THE FINDINGS

- 3.1 In spite of the usually small activities involved, a general release from incorporation control obligations for radiation workers in nuclear diagnostics is not justified considering their contribution to incorporation statistics.
- 3.2 It is not the lowest detectable radiotoxicity range that shows the highest frequency of incorporations, which is indicative of a "non-linear" intake if working conditions admit of any uptakes of radioactive material at all.
- 3.3 The distribution of the recorded incorporation cases over the 34 detected radionuclides and the preset radiotoxicity ranges, which has been obtained from the surveillance of all the significant applications of unsealed radioactive material in all walks of modern life apart from nuclear technological research and nuclear industry and which covers the majority of radiation workers in the 17 million population of NW and a time span of more than a decade, shows that there are only a few radionuclides constituting an appreciable incorporation hazard under normal conditions.

REFERENCES

- (1) "MINISTERIALBLATT FÜR DAS LAND NORDRHEIN-WESTFALEN - Ausgabe A -", 21. Jg. Nr. 107 (ausgegeben zu Düsseldorf am 16.8.1968) 1968  
 (2) "DIRECTORY OF WHOLE-BODY RADIOACTIVITY MONITORS", GY 10.1, International Atomic Energy Agency, Vienna (1970)

PERIOD	0.1 - 1 (ZMPBB) <sub>?</sub>		1 - 10 (ZMPBB) <sub>?</sub>		10 - 100 (ZMPBB) <sub>?</sub>		100 - ... (ZMPBB) <sub>?</sub>	
	I <sup>131</sup>	I <sup>125</sup>	I <sup>131</sup>	I <sup>125</sup>	I <sup>131</sup>	I <sup>125</sup>	I <sup>131</sup>	I <sup>125</sup>
1974	35D+20DT	1D	34D+19DT	3D	7D+ 7DT	0	1DT	0
1975	58D+18DT	4D+1DT	37D+14DT	5D+1DT	6D+ 3DT	0	0	0
1976	82D+12DT	7D	50D+10DT	1D	6D+ 1DT	0	2D	0
74-76	175D+50DT	12D+1DT	121D-43DT	9D-1DT	19D+11DT	0	2D + 1DT	0

LEGEND (ZMPBB)<sub>?</sub> : Percentage of the Maximum Permissible Body Burden calculated according to the ICRP Recommendations on the disputable assumption (emphasized by the subscript ?) that the determined incorporation value represents an Annual Incorporation Average for the monitored person and the detected radionuclide

D or DT : Incorporations due to the handling of IODINE-131 and IODINE-125 for sole DIAGNOSTIC or for DIAGNOSTIC and THERAPEUTIC purposes

TABLE 1 Preponderance of Iodine Incorporations due to Nuclear Diagnostics Over Those due to Nuclear Therapeutics in Monitored Medical Personnel

PERIOD	MEASUREMENTS			RADIATION WORKERS			LEGEND
	HBC	LSC	FUU	HBC	LSC	FUU	
1964	783	0	0	248	0	0	HBC: Human Whole-Body Counting
1965	685	48	0	154	25	0	
1966	453	197	16	205	50	-	
1967	507	351	36	280	180	-	LSC: Liquid Scintillation Counting
1968	450	396	20	287	180	-	
1969	414	527	50	295	350	-	FUU: Fluorometric Urinalysis for Uranium
1970	519	706	49	403	322	26	
1971	308	623	46	270	321	-	
1972	553	573	434	417	258	80	
1973	508	707	238	423	328	78	
1974	606	697	291	570	456	89	
1975	932	614	319	889	376	81	
1976	1155	1158	256	1112	498	82	
1964-76	7873	6597	1755				

TABLE 2 Incorporation Control Measurements and Monitored Radiation Workers

PERIOD	0.001-0.01 (ZMPBB) <sub>2</sub>		0.01 - 0.1 (ZMPBB) <sub>2</sub>		0.1 - 1 (ZMPBB) <sub>2</sub>		1 - 10 (ZMPBB) <sub>2</sub>		10-100 (ZMPBB) <sub>2</sub>		100 - ... (ZMPBB) <sub>2</sub>		1 - 10 (µg/l)	10 - ... (µg/l)	
	HBC	HBC	LSC	HBC	LSC	HBC	LSC	HBC	LSC	HBC	LSC	HBC	LSC	FUU	FUU
1964	0	1	0	3	0	9	0	3	0	2	0	0	0	0	0
1965	0	0	0	3	36T	5	12T	2	0	0	0	0	0	0	0
1966	1	2	0	6	53T	10	36T	5	7T	0	1T	0	0	0	0
1967	1	5	0	13	24T	17	25T	13	1T	3	0	0	0	0	0
1968	0	3	0	9	42T	15+1M	12T	5+3M	2T	2M	0	0	0	0	0
1969	1	9	49T	25	36T	24	16T	10	2T	2	0	1	0	0	0
1970	2	12	47T	47	83T	29+2M	30T	7+2M	0	1+ 2M	0	12	1	1	1
1971	0	11	30T	49	89T	27	33T	6	1T	1M	0	41	5	5	5
1972	9	47	23T	63-1M	105T	46+5M	36T	9	7T	3	0	13	7	7	7
1973	6	21	38T	67	104T	49+1M	46T	8	3T	2M	0	6	0	0	0
1974	23	57	72T	84+1M	90T	66+1M	55T- 7C	17+2M	4T	1- 1M	0	4	0	0	0
1975	38	55	66T	107+1M	92T	67+1M	38T+ 7C	12	4T	1+ 5M	0	9	0	0	0
1976	88	123	79T	153	111T	76	73T+ 7C	8	3T	2+ 7M	0	5	0	0	0
1964-76	169	346	404T	629+3M	865T	440+11M	412T+21C	105+7M	34T	15+20M	1T	91	13	13	13

LEGEND (ZMPBB)<sub>2</sub> , HBC , LSC , FUU : cf. TABLE 1 ; T : Tritium incorporation(s) ; C : Carbon-14 incorp.(s)

M : Incorporations attributable to Medical Treatment of radiation workers and being remarkable for their possibly misleading or masking potentials

TABLE 3 Frequency and Significance of Detected Incorporations by the HBC, LSC and FUU Methods

(ZMP3B) <sub>2</sub>	0.001-0.01	0.01-0.1	0.1-1	1-10	10-100	100 - ...
RADIONUCLIDE						
1) SODIUM-22		1				
2) SCANDIUM-46			1			
3) CHROMIUM-51		1	1			
4) MANGANESE-54		16	14	1		
5) IRON-59	1	1	3	1		
6) COBALT-57		1				
7) COBALT-58	1	20	13	3		
8) COBALT-60	1	8	19	2		
9) ZINC-65	2	20	6			
10) ARSENIC-74			1			
11) SELENIUM-75	40	25		1		
12) RUBIDIUM-86			1	1		
13) STRONTIUM-85	5	5				
14) NIOBIUM-95			1	1		
15) TECHNETIUM-99m	117	169	72	24	3	
16) ANTIMONY-124		1				
17) IODINE-125	3	31	21	21		
18) IODINE-131		18	414	399	91	10
19) CESIUM-137		2	1		2	
20) BARIUM-133		1				
21) TERBIUM-160			1			
22) YTTERBIUM-169			1			
23) HAFNIUM-175			1			
24) HAFNIUM-181		2	5			
25) TANTALUM-182			1			
26) OSMIUM-191			1	1		
27) GOLD-198	1	7	3			
28) MERCURY-197			2	1	1	
29) MERCURY-203		14	50	1	1	
30) LEAD-212 (THORIUM B)				1	3	5
31) RADIUM-226				1	2	1
SUM TOTAL	171	343	633	459	103	17

TABLE 4 Synoptic Presentation as to Radionuclide and Significance of all the Incorporations Recorded During the 1964-76 Period Exclusive of Tritium, Carbon-14, and Uranium Incorporations, Which are Already Presented in TABLE 3

UN APPAREIL PERSONNEL POUR LA DOSIMETRIE  
DES DESCENDANTS DU RADON

Philippe DUPORT

Commissariat à l'Energie Atomique  
Institut de Protection et de Sécurité Nucléaires  
Département de Protection

Section Technique d'Etudes de Pollution dans l'Atmosphère et dans les Mines  
B.P. n° 6, 92260 Fontenay-aux-Roses, France

## 1. INTRODUCTION

Une bonne connaissance du risque radioactif encouru par les mineurs d'uranium nécessite l'emploi d'un appareil autonome, individuel, prélevant continuellement les aérosols présents dans le chantier, pendant toute la durée du poste de travail, et cumulant son enregistrement pendant une période fixée (quinzaine, mois, etc.).

Pour cette dosimétrie, nous associons un détecteur ionographique, enregistrant dans la matière le passage d'une particule lourde ionisante, à un appareil de prélèvement autonome, d'une grande fiabilité.

Les premiers résultats concernant le prototype développé ici ont été présentés à Bucarest (1).

## 2. DESCRIPTION DE L'APPAREIL

### 2.1. Principe de la détection

On utilise pour la détection des particules  $\alpha$  le film de nitrate de cellulose LR 115 de Kodak Pathé. La couche sensible, rouge, épaisse de  $13 \mu\text{m}$ , est déposée sur un film de mylar incolore.

Le passage d'une particule  $\alpha$  dans le nitrate affecte la structure de la matière de telle sorte que, si l'énergie de la particule incidente est bien choisie ( $1 < E < 3,5 \text{ MeV}$ ), une attaque chimique appropriée fait apparaître des trous réguliers dans le détecteur. Les traces dues à des  $\alpha$  d'énergie suffisamment éloignées des limites n'apparaissent pas à la lecture.

Ces conditions sont réalisées par un dispositif breveté (2) comprenant un collimateur à deux canons, terminés chacun par un écran (figure 1).

Les parcours des  $\alpha$  dans l'air et les écrans sont tels que les canons du collimateur déterminent sur le détecteur deux plages irradiées, l'un ne détectant que le  $^{218}\text{Po}$ , l'autre le  $^{214}\text{Pb}$ .





Schéma de la tête de mesure FIG. 1

Nous avons donc un discriminateur d'énergie qui permet au film détecteur d'intégrer, sur la période choisie, la quantité de particules  $\alpha$  potentielles contenue dans un volume d'air connu.

Le rendement de détection de l'appareil est  $6,9 \cdot 10^{-4}$ .

## 2.2. Principe de la mesure

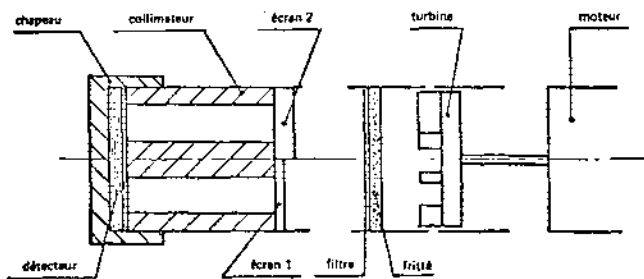
On compte les traces qui traversent entièrement la couche de nitrate de cellulose. On peut dénombrer les traces au microscope optique, ou encore, pour éviter ce procédé fastidieux, évaluer la quantité de lumière transmise par ces taches en utilisant l'appareillage décrit par le schéma de la figure 2.

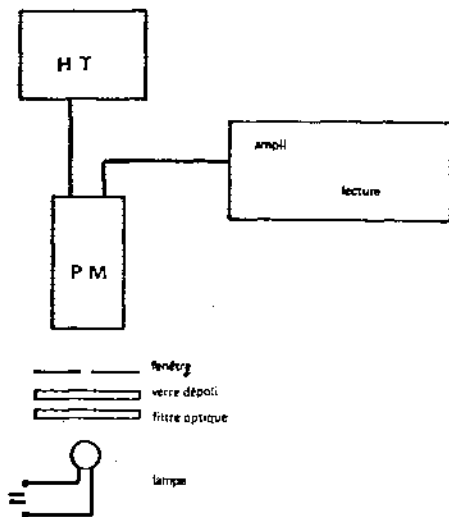

Lecteur de films FIG. 2

Compte tenu du rendement de détection et du débit de prélèvement, on mesure aisément une ambiance radioactive équivalente à 0,05 WLM.

### 3. TECHNOLOGIE DE L'APPAREIL

Le dosimètre est constitué d'un corps cylindrique métallique contenant l'accumulateur, le système de commutation charge-marche, le groupe moteur-turbine.

L'autonomie de l'ensemble, en service continu, est d'environ 15 heures. La turbine crée une dépression suffisante pour assurer un débit d'environ 5 litres/h à travers une membrane filtrante Millipore RAWP.

Six de ces appareils sont portés en permanence par des mineurs des mines d'uranium en France, depuis mai 1976, et 60 depuis février 1977.

Ces essais en chantier ont permis de constater que cet appareil est effectivement capable d'assurer la dosimétrie des descendants du radon dans les mines d'uranium.

### 4. CONCLUSION

On a réalisé un appareil autonome, de faible encombrement, de faible poids, capable de mesurer séparément la radioactivité des  $^{218}\text{Po}$  et  $^{214}\text{Bi}$  présents dans l'atmosphère des mines d'uranium. Sous réserve du renforcement des paliers du moteur, la tenue électrique et mécanique de l'ensemble est satisfaisante. Le débit choisi permet une bonne lisibilité.

### REFERENCES

- (1) A.M. CHAPUIS, D. DAJLEVIC, Ph. DUPORT, G. SOUDAIN, Communication au Congrès de Bucarest, Juillet 1976
- (2) Brevet CEA 72 25 550

## A PERSONAL TRITIUM INTAKE MONITOR

S. Pszona, K. Gradowski  
Radiation Protection Department  
Institute of Nuclear Research, Swierk, Poland

## 1. INTRODUCTION

Tritium in the form of water vapour is the most widespread contaminant of air of nuclear power plants, neutron generators, luminous paint industry, etc. Radiological hazard to persons occupationally exposed to tritium oxide arises exclusively from internal contamination. Assessment of the potential risk and absorbed dose from tritium oxide intake is usually based on biological monitoring i.e. on analysing of excreta samples for tritium content. The main difficulties encountered in the way for proper assessing the dose received by the critical organs following tritium oxide intake can be summarize as follows:

1. due to short biological lifetime of tritium in a body the sampling period of biological excreta has to be also short, 14 days at least,
2. model of intake of tritium oxide has to be assumed which is usually far from the real condition of intake of tritium, being the main source of uncertainties of dose determination,
3. routine biological monitoring needs close cooperation between the staff responsible for radiation protection and exposed persons at working area. This is the most difficult in practice.

Due to these facts a personal tritium intake monitor /PTIM/ has been developed /1/, which in principle can facilitate the problem of estimation of dose commitment due to tritium oxide intake.

## 2. METHOD AND DEVICE

For proper assessing of dose commitment for a person exposed to tritium oxide the total amount of tritium which was intaken during a given working time has to be estimated. It is well known that biological monitoring is unable to give such information. The idea of personal tritium intake monitor /PTIM/ is

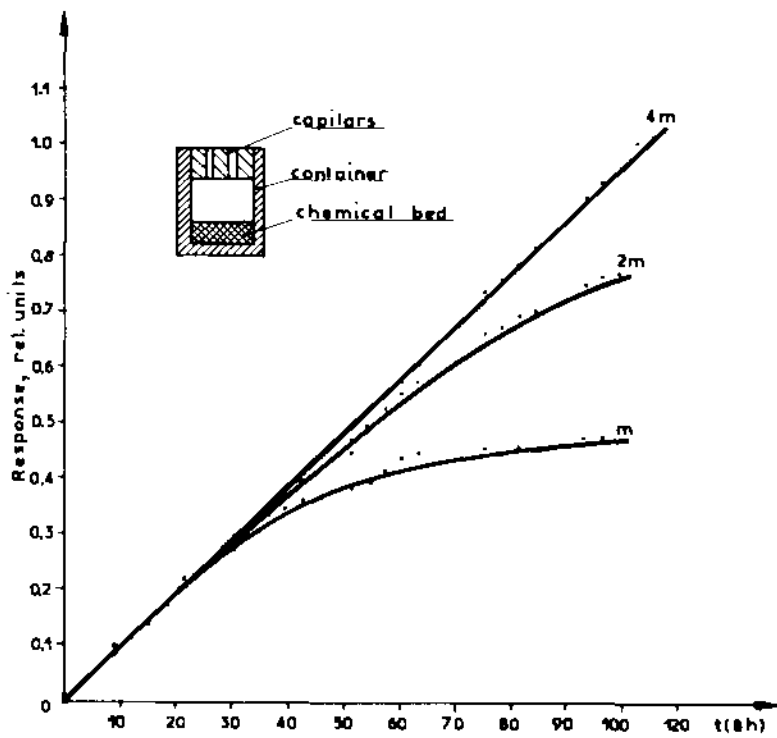

Fig. 1. Left upper corner - schematic view of personal tritium intake monitor, Response of personal tritium intake monitor as a function of time for different mass  $m$  of  $P_2O_5$ .

based on absorption of tritium oxide as well as water vapour by a chemical bed containing  $P_2O_5$ . The rate of absorption of tritium  $dA/dt$  by an absorber should, over the period of using of the device, be proportional to tritium oxide concentration in air i.e.

$$\frac{dA}{dt} = k C/t/ \quad /1/$$

where:  $C/t/$  - is concentration of tritium oxide in air at time  $t$   
 $k$  - proportionality coefficient determined by a calibration.

At the same time the rate of intake of tritium oxide by a person is also proportional to concentration  $C/t/$ . It means that at certain conditions the response of PTIM could follow the intake of tritium by a person wearing such device and the following relation exists:

$$A = KI \quad /2/$$

where:  $A$ - total activity of tritium collected by PTIM  
 $I$ - total intake by a person  
 $K$ - proportionality coefficient

The needed response of PTIM was achieved by enclosing a chemical bed  $/P_2O_5/$  in a container having controlled leak trough the capillars as schematically shown on fig. 1. The response was checked in air in saturated water vapour condition at  $20^\circ C$  and shown on fig. 1. As seen from fig. 2 depending on the mass of a chemical bed the linearity of device can be well controlled. Tritium oxide forms with  $P_2O_5$  phosphoric acids which when dissolved with water and neutralized can be measured directly by liquid scintillation method with practically no quenching effects.

### 3. CALIBRATION

PTIM was calibrated in a box in which concentration of tritium oxide in air was determined by an ionization chamber having known volume. It was found that coefficient  $k$  in equation  $/1/$  is equal to  $11 \mu Ci/h / \mu Ci/cm^3$ .

Evaluation of coefficient  $K$  in equation  $/2/$  expressing the proportionality coefficient between tritium collected with PTIM and

total intake of tritium by a "standart man" can be done by assuming the 100% efficiency of tritium oxide penetration into body fluid and that the same amount of tritium infiltrates trough skin. This gives K equal  $1,7 \cdot 10^5$  /see equation 2/.

#### 4. COMPARISON WITH BIOLOGICAL MONITORING

In order to compare the results given with PTIM and biological monitoring the selected number of workers in two laboratory were chosen. Within six working days the urine samples were taken every two days. It was found that results obtained with PTIM were systematically higher by a factor 6 + 8, /2/ which were attributed to very approximate calculation of coefficient K. In fact there is lack of literatures dealing with the efficiency of intake of tritium oxide into a body. Further intercomparison is in progress. Sensitivity of PTIM was determined on the level of 1  $\mu$ Ci in the body when a typical liquid scintillation spectrometer was used for measuring tritium activity.

#### 5. CONCLUSIONS

As it has been shown the personal tritium intake monitor, depending upon the amount of a chemical bed, can be used even for a period of 3 month. Tritium oxide integrated by PTIM is measured directly with liquid scintillation counter using dioxan based scintillator. The sensitivity of PTIM expressed in total tritium intake is 1  $\mu$ Ci. PTIM is specially suitable for those laboratories where large number of workers have to be monitored with rather low intake of tritium for a long period.

#### REFERENCES

- 1 Gradowski, K., Pszona, S. "Personal tritium intake monitor", INR Report 1492/XIX/DIA, 1974.
- 2 Gradowski, K., Pszona, S., Chrzanowska, E. Internal Report O-61/XIX/76, 1976.

On the distribution of the radiation doses from thick targets in high energy electron accelerators.

A. Esposito<sup>M</sup>, F. Lucci<sup>X</sup>, M. Pelliccioni<sup>M</sup>

(<sup>M</sup>) INFN - Laboratori Nazionali di Frascati - Italy

(<sup>X</sup>) CNEN - Centro di Frascati - Italy

Any massive object on which a high energy beam targets, will constitute an important source of secondary radiations. The knowledge of this radiation field, its nature and its angular distribution is of high interest for various health physics respects, including shielding calculations and dose estimates for accidental overexposures.

For the electron accelerators we must consider electron or bremsstrahlung beams. In both cases an electromagnetic cascade shower is produced in the target with the consequent photoproduction of several particles, mainly neutrons and protons and, if it is energetically possible, pions and  $\mu$  mesons. Anyhow the principal contribution to the radiation doses near the targets will be always due to the electromagnetic component and, to a lower extent, to the neutrons one.

Now we remember two general properties of e.m. showers which can be used in the radioprotection work and have been established

mainly by a critical comparison of Monte Carlo calculations and experimental results. First the study of longitudinal development has permitted to establish the model that the shower propagates at great depths principally by means of the most penetrating  $\gamma$ -rays in the material. The second relevant property concerns the radial escaping curve, i.e. the fraction of the incident energy escaping from an infinitely long cylinder versus its radius, which depends only from the radius in Molière units, irrespective of the absorber material and the particle energy (see fig. 1).

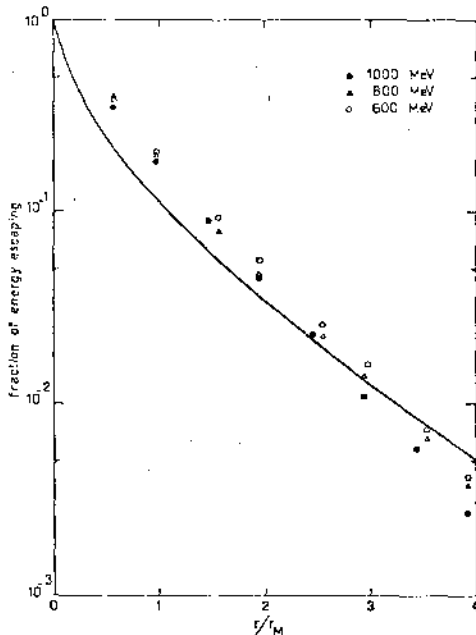

Fig. 1 - Radial escaping curve for 1 GeV bremsstrahlung beams on concrete.

The two said circumstances often permit to roughly evaluate the doses near a target in the radial direction. In many other cases it is however necessary to employ experimental data (1-4).

In this condensed paper it is only possible to mention our results on distribution of doses produced by a 1 GeV bremsstrahlung beam striking W targets of various thicknesses (see fig. 2). The data include background contamination, which yet has been found to be unimportant except for the wide angle measurements with thin targets.

The main characteristic of the experimental curves is the strong dependence of their behavior on angle. In fact the small angle curves show a broad maximum and then decrease with increasing phantom depth, while the large angle ones are always decreasing.

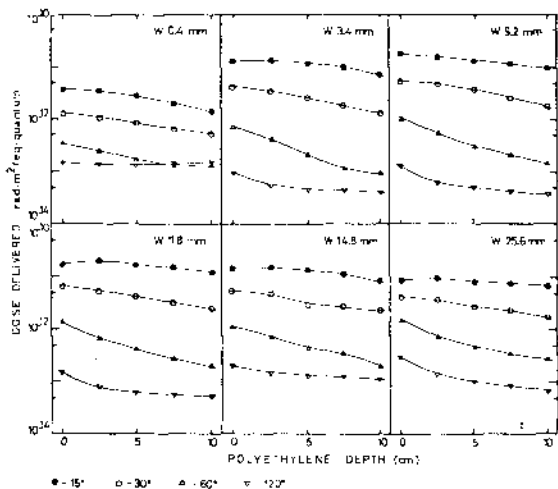

fig. 2 - Dose distribution around W targets struck by a 1 GeV bremsstrahlung beam (the data were measured inside a polyethylene phantom).

This can be explained assuming that the high energy particles contribution dominates in the forward direction, while the low energy particles are predominant at large angles.

Of course, for a fixed depth, the dose decreases strongly for increasing angles.

For thick targets this angular anisotropy is less evident, because the fraction of the shower absorbed in the target increases, thus decreasing the dose at small angles. While the wide angle contribution, which is due mainly to the limited transverse dimension of the target (the same for all thicknesses), stays practically constant.

Furthermore we point out that the doses at 60° and 120° are consistent with the values computed according to the said general properties ( $4, 8, 10^{-14}$  rad.m<sup>2</sup>/GeV for the W targets).



The data for zero depth are also shown in fig. 3, as function of the target thickness expressed in radiation lengths. The figure shows that the maximum dose normally corresponds to a thickness equal to the maximum shower development (about 3.36 r.l.), as foreseen by the shower theory.

The previously exposed notions can be applied to the various operational health physics problems (shielding design, estimates of accidental overexposures, work planning in areas without shielding or with poor shielding or so on). Here we want examine two examples.

As accidental exposures are concerned, let us suppose that a man would stay few minutes near a part of the machine acting like a thick target.

If the beam strikes the target normally, it is of course easy to employ the previously reported data, if available. As an example we can consider a bremsstrahlung beam hitting normally a tungsten target with an intensity of  $10^{10}$  equivalent quanta per second. In this case the dose that would be absorbed by a man staying 2 minutes at a distance of 50 cm from the target can be evaluated from the figg. 2 and 3. Its value lies between 1.5 rad and 95 rad depending from the angle.

The previous case has the peculiarity of a very simple geometry with a point source which is well localized. Practical cases are however often more complex with a distribution of the losses which cannot be "a priori" well understood and with small angles of incidence.

Another example of application of experimental data to a practical problem is the evaluation of the doses near the storage ring Adone due to a sudden loss of the stored beams. In this case, the starting point was an experiment by Jenkins et al. (3) on the angular distribution of radiation around some plates on which a 2 GeV electron beam was targetting at small angles. We considered the two extreme cases of uniformly distributed losses and of a single point loss.

The results are shown in fig. 4, versus the distance between the point of interest and the center of the ring. The top of fig. 4 shows the doses calculated assuming that the source radiates

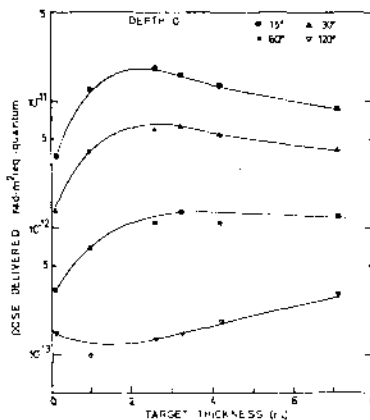

Fig. 3 - Doses at 0 depth measured at various angles versus the W target thickness.

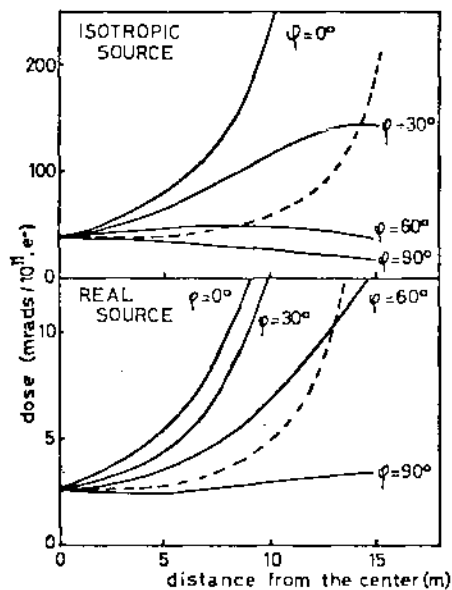

Fig. 4 - Doses inside the Adone Hall in the cases of uniformly distributed losses (dashed curves) or point losses (full line curves), for various azimuthal angles  $\varphi$  between the source and the point of interest.

isotropically for all the angles greater than  $20^\circ$  (with the same strength measured at  $20^\circ$ ), while the bottom refers to the real angular distribution of secondary radiations. All the dose values have been normalized to  $10^{11}$  electrons lost along the ring.

#### REFERENCES

- 1) S. M. Wyckoff et al., Proc. Int. Congress on Protection against Accelerator and Space Radiation, CERN, vol. 2, p. 773, 1971.
- 2) R. B. Neal ed., The Stanford Two-Miles Accelerator, W. A. Benjamin Inc., 1968.
- 3) T. M. Jenkins et al., SLAC TN-70-34, 1970.
- 4) A. Esposito et al., Nucl. Instr. Meth., 138, 209, 1976.

## SHIELDING OF FAST NEUTRONS FROM CYCLOTRON TARGETS

P.F. Sauer mann, W. Friedrich, J. Knieper, K. Komnick and H. Printz  
 Nuclear Research Center Jülich, FRG  
 Institute of Chemistry, Health Physics Group

1. INTRODUCTION

A great number of compact cyclotrons for use in medicine, biology and physics will be installed in the near future. Unfortunately, the shielding design for these high yield machines is, however, more a question of skill than of science. To help improve this situation the Experimental Shield Testing Facility was established at the compact cyclotron CV-28 of the Nuclear Research Center Jülich. In this facility the attenuation of neutrons from different cyclotron targets in concrete has been studied, using deuteron beams on Be, C, Al, Fe, Cu, Ta and Pb. In this paper attenuation factors for ordinary concrete are presented as a function of shield thickness.

2. EXPERIMENTAL SHIELD TESTING FACILITY

The performance data of the compact cyclotron CV-28 are specified in (1). Figure 1 shows the components of the Experimental Shield Testing Facility (2). The main component is the movable part of shield enabling us to vary the thickness of the concrete shield between zero and 160 cm in steps of about 10 cm. The shield consisted of ordinary concrete slabs ranging in size from 115 x 115 cm<sup>2</sup> to 155 x 155 cm<sup>2</sup>.

3. TARGETS

A multiple target system with seven target positions was used. Target materials and expected neutron yields are specified in the table. The multiple target system is shown in figure 2. A detailed specification is given in (2).

4. MEASUREMENTS

The measurements of the dose equivalent rates of neutrons and  $\gamma$ -radiation were carried out, using a rem counter according to Andersson and Braun (6) and an ionisation chamber VAJ-15 (7), respectively. The energy of deuterons was 14 mev, the target current strength 13  $\mu$ a.

5. RESULTS

The results are summarized in figures 3 and 4. In figure 3 attenuation factors

$$k = \frac{D_0}{D}$$

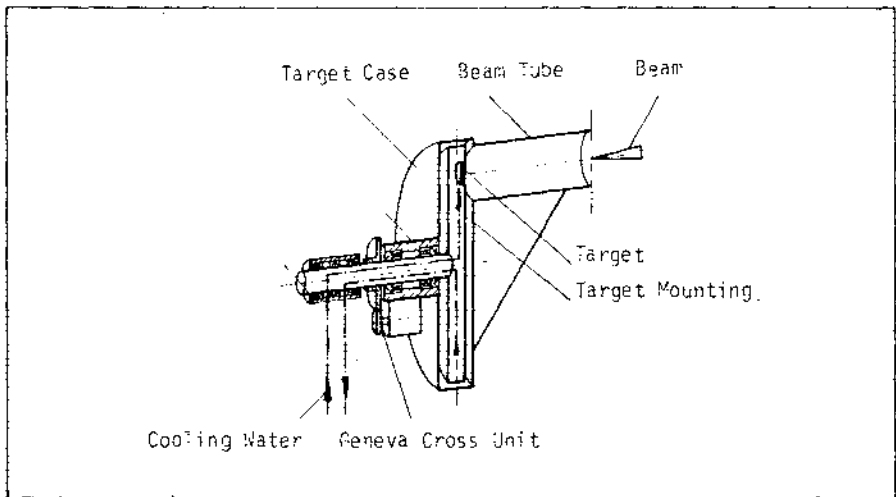
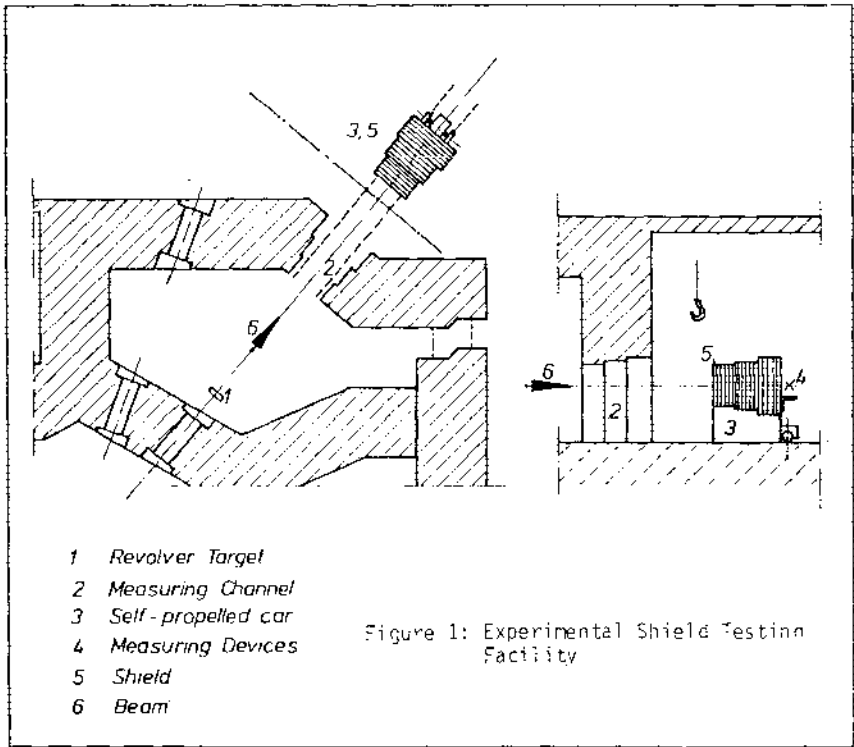

No	Target Material	Thickness mm	Neutron Yield $\mu\text{a}^{-1}\text{s}^{-1}$	Deuteron Energy mev	Reference
1	Be	4.0	$1.9 \cdot 10^{10}$	15	3
2	C	4.0	$1.3 \cdot 10^{10}$	10	4
3	Al	3.2	$6.4 \cdot 10^9$	15	5
4	Fe	1.5	---	--	-
5	Cu	1.5	$2.9 \cdot 10^9$	15	3
6	Ta	1.0	$3.3 \cdot 10^9$	15	3
7	Pb	2.0	---	--	-

Thick target materials and yields

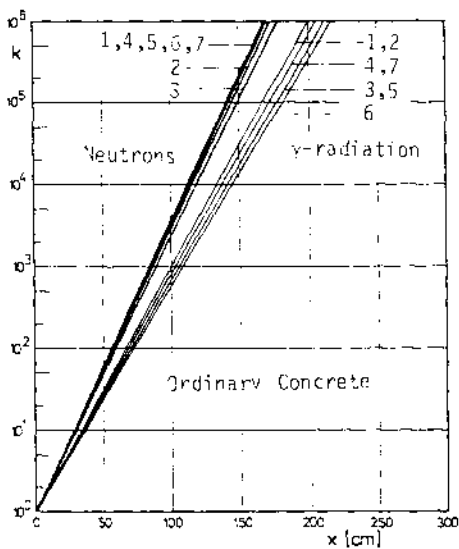

Figure 3: Attenuation factor against shield thickness

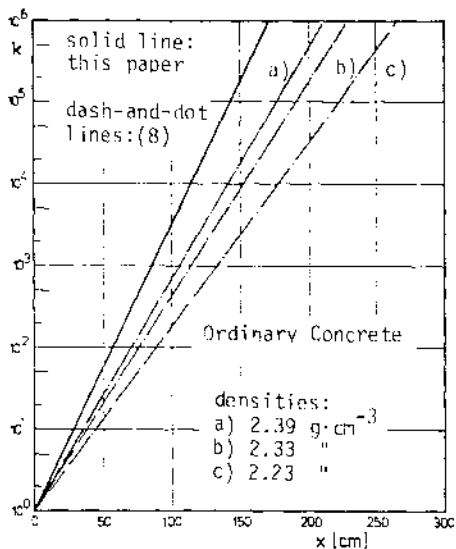

Figure 4: Attenuation factor against thickness. Beryllium target.

( $\dot{D}_0$ : dose equivalent rate without shield;  $\dot{D}$ : dose equivalent rate behind shield)

are plotted against shield thickness for neutrons (left family of curves) and  $\gamma$ -radiation (right family of curves). The numbers refer to the table. In figure 4 attenuation factors for neutrons from the beryllium target (left curve) are plotted against shield thickness as compared to former results of a semiempirical investigation on compact cyclotron shielding by ordinary concrete (8).

Our results may be summarized as follows:

1. The shield thickness is determined by the shielding of fast neutrons (figure 3).
2. The attenuation of neutrons produced by deuteron beams in cyclotron targets is nearly independent of the target material (figure 3). The required shield thickness, therefore, only depends on the neutron yield obtained by the different target materials (table). The "critical" target materials are beryllium and carbon.
3. Attenuation factors we determined by semiempirical methods are "on the safe side" (figure 4).

## 6. CONCLUSION

Ordinary concrete compact cyclotron shields computed on the basis of attenuation data evaluated by the above mentioned semiempirical method are oversized by about 20%. The data presented in this paper will enable engineers and physicists to compute such shields more precisely.

## 7. REFERENCES

- (1) The Cyclotron Corporation: Equipment specification No. 6021, March 1971.
- (2) W. Friedrich, J. Knieper and P.F. Sauer mann: Internal Report, KFA Jülich, Institute of Chemistry, Dec. 1975.
- (3) W.E. Crandell et al.: J. Appl. Phys. 28, 273 (1957).
- (4) L.W. Smith and P.G. Krüger: Phys. Rev. 83, 1137 (1951).
- (5) A.J. Allen et al.: Phys. Rev. 81, 536 (1951).
- (6) I.O. Andersson and J. Braun: Report AE - 132 (1964).
- (7) G. Schubert: Vakutronik-Informationen 1/1964, Febr. 1964.
- (8) P.F. Sauer mann: JUL - 751 - PC, April 1971.

## SPECTRA AND DOSIMETRY OF NEUTRONS INTERACTING WITH CONCRETE SHIELDING

W.G. Cross and H. Ing  
Atomic Energy of Canada Limited, Chalk River Nuclear Laboratories  
Chalk River, Ontario, K0J 1J0, Canada

## 1. INTRODUCTION

This paper is concerned with two separate neutron shielding problems. The first is the lack of agreement between measured and calculated values of the attenuation for 14-MeV neutrons. The second is the discrepancy between measured and calculated values of the fraction of dose-equivalent (D.E.) delivered by "intermediate energy" neutrons around reactor or accelerator shielding.

## 2. ATTENUATION OF 14.7-MeV NEUTRONS IN CONCRETE

Despite the widespread use of 14-MeV neutron generators, there is still no experimental consensus on the dose attenuation of concrete shielding for 14-MeV neutrons. Both calculations and measurements show that, for thicknesses  $> 40$  cm, attenuation is nearly exponential and thus has an attenuation length  $\lambda$ . However, calculated values of  $\lambda$  are between 12 and 13 cm (for "ordinary" concrete of density  $2.3 \text{ Mg/m}^3$ ) while measured values, taken respectively from references 1 to 7, are 15.6, 19.7, 15.6, 17.5, 19.6, 15.1 and 15 to 23 cm. Thus there is not only disagreement among different experiments but all the experimental values exceed the calculated ones. Variations in composition are not large enough to account for these discrepancies, as will be shown later.

We have used a modified version of the OSR Monte Carlo code and nuclear data from the ENDF/B IV library to calculate the spectra and kerma of neutrons transmitted through concrete. Further details are given in Ing and Cross (8). The incident neutrons were either in a broad beam normal to the face of a block 100 cm thick or from an isotropic source distributed uniformly on the surface, these being limiting cases of incident angular distributions in practice. Spectra were calculated at various depths in the block and also for neutrons transmitted by slabs of various thicknesses. Figure 1 shows examples of spectra. The quantity plotted is  $E \phi(E)$  where  $\phi(z)$  is the fluence/MeV at energy  $E$ . The curves are displaced vertically by arbitrary amounts.

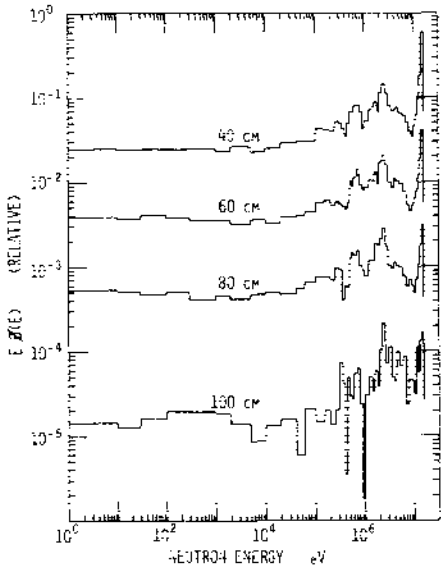

Figure 1. Calculated spectra at various depths in a concrete block, for normally-incident 14.7 MeV neutrons.

The "standard" concrete composition was, in percentage by weight, 0.61 H, 54 O, 34 Si, 5.3 Al and 6.5 Ca. The hydrogen content corresponds to about 6% water. The calculations were repeated with (a) the fraction of H doubled, (b) oxygen reduced to 35% by replacing it with the heavier elements and (c) Ca and Al replaced

by Si. Figure 2 shows the effects of these rather extreme changes. The attenuation lengths range from 12.0 to 14.1 cm.

The calculated attenuation length for the "standard" composition, at depths between 40 and 100 cm, is 13.5 cm. For comparison, other Monte Carlo and discrete ordinates calculations, all on concrete with about the same H content, give 12.1 (9), 12.0 (10) and 12.9 (11) cm, where all lengths are for a specific gravity of 2.3. In these calculations the compositions assumed differed from ours in that much of the  $\text{SiO}_2$  was replaced by  $\text{CaCO}_3$  and we estimate that this difference accounts for at least half the difference in attenuation lengths obtained. Thus there are no significant discrepancies among these calculated values. Figure 3 compares the calculated attenuation in a large block, for normal (curve A) and isotropic (curve C) incidence and the transmission through slabs of various thicknesses for normal incidence (curve B). For all 3 curves the value of  $\lambda$  is nearly the same.

We have also measured the dose attenuation of 14.7-MeV neutrons in a large (2 x 2.4 x 1.4 m) assembly of concrete bricks, with the source 1.4 m from one face of the assembly. Two experiments were done. In the first, a Dennis-Loosemore dosimeter (FN2/3) was placed at different depths in the assembly, up to 100 cm. In the second,  $^{237}\text{Np}$  damage-track detectors were placed at 10 cm depth intervals and all irradiated simultaneously. Spectra calculated for each detector position, along with the known energy responses of the dosimeter and track detector, were used for converting detector readings to kermas. Differences from some previous measurements were (a) the correction of detector readings for spectral variations, (b) the "infinite" lateral dimensions of the block, (c) the geometry of the experiment was nearly the same as that of the calculations and (d) the detectors were always well shielded (by > 40 cm concrete) from room-scattered neutrons.

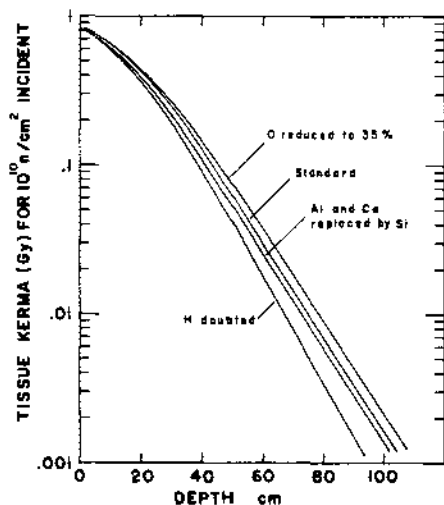

Figure 2. Effect of concrete composition on attenuation. Details are given in the text.

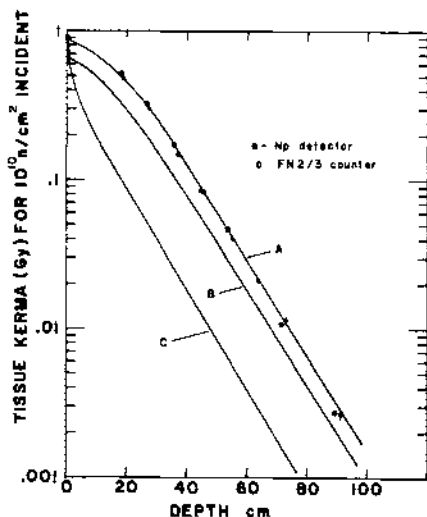

Figure 3. Comparison of measured and calculated (curve A) attenuation for 14.7-MeV neutrons incident normally on a large concrete block. Curves B and C are described in the text.



The measured variation of kerma is shown in Figure 3 by the points, while curve A shows the calculated variation in a large block. Measured values for the attenuation length were  $12.9 \pm 1$  cm for the counter measurement and  $13.6 \pm 1$  cm for the Np detector measurement. In contrast to previous measurements these results are in agreement with the calculated values and imply that concrete shielding is more effective than would be deduced from earlier measurements.

### 3. THE DOSE-EQUIVALENT FRACTION FROM INTERMEDIATE ENERGY NEUTRONS

"Intermediate energy neutrons" are those between thermal energies and the threshold of some fast neutron detector, typically around  $10^5$  eV as will be assumed here. Dose equivalents from these neutrons are often determined by subtracting the fast and thermal-neutron components, measured by appropriate detectors, from the total D.E. measured by a "rem-meter". Such measurements sometimes (12, 13) yield D.E. fractions from intermediate energy (I-E) neutrons in excess of 80%. In contrast, calculated spectra of neutrons transmitted through shielding have given much lower D.E. fractions. This discrepancy has been discussed by Reinzelmann (14). Here, we discuss the enhancement of I-E neutrons by transmission and reflection of neutrons by concrete and its effect on the fractional D.E.

Monte Carlo calculations, as described above, were used to obtain spectra of neutrons that had penetrated various thicknesses of concrete, up to 100 cm. The spectra of incident neutrons included 2.8 and 14.7-MeV neutrons, unmoderated fission neutrons and neutrons from light and heavy water reactors. As examples, the latter two spectra, and those produced by passing these neutrons through 60 cm of concrete are shown in Figure 4. By calculating the proportion of D.E. delivered by I-E neutrons in such spectra, the following conclusions were reached:

- (a) the relative I-E fraction increases at depths up to 10 or 20 cm but at greater depths it decreases,
- (b) the I-E component of the incident beam has negligible effect on the I-E component at depths of 60 cm or more. At 60 cm, between 5 and 10% of the D.E. is delivered by I-E neutrons,
- (c) at depths greater than 100 cm the penetration is dominated by 2.3-MeV neutrons (at the "window" of the oxygen cross section). Results of 2.8-MeV neutrons through concrete indicate that the proportion of I-E neutrons from a 2.3 MeV source would either decrease further or remain constant up to depths of at least 180 cm.

Thus the transmission of neutrons through concrete clearly cannot result in a high D.E. fraction from I-E neutrons.

To study the effects of multiple reflection we calculated the spectrum of reflected neutrons arising from normally-incident fission-spectrum neutrons. The resulting neutrons were then assumed to be incident normally on a second concrete surface and the scattered spectrum was again calculated. The process was repeated for a third scattering. The results are shown in Figure 5. At each scattering the fraction of D.E. from I-E neutrons increases by about a factor of 2, the value after three scatterings being 24%. When the thrice-scattered neutrons were transmitted by 30 cm of concrete, the I-E fraction of the D.E. decreased by a factor of 2.

Many reflections can thus, in principle, produce a high proportion of D.E. from I.E. neutrons. However the increase can only occur if only reflected neutrons can contribute to the D.E., e.g., at bends in a shielding maze. Reflections back and forth from the walls of a shielded room do not give a large fraction of I-E neutrons since most of the fluence in the room comes from the original source. Reflections from the walls of a straight tunnel were also found to increase the unscattered D.E. at the far end by only a small fraction.

While a high proportion of the D.E. from I-E neutrons is possible, the type of scattering that occurs in most practical shielded areas makes this unlikely. It seems more probably that the high values measured arise from the uncertain energy response of rem-meters, especially in this energy region.

#### REFERENCES

- (1) L.R. Day and M. Mullender, UKAEA Report, AWRE NR-1/63 (1963)
- (2) J.J. Broerse and F.J. van Werven, Health Physics 12, 83 (1966)
- (3) J. Hacke, Int. J. App. Radiation and Isotopes, 18, 33 (1967)
- (4) J.J. Broerse, Int. J. App. Radiation and Isotopes, 19, 74 (1968)
- (5) P.F. Sauer mann and W. Schäfer, Kerntechnik, 11, 197 (1969)
- (6) T.O. Marshall and A. Knight, Proc. of Conf. on Radiation Protection, Rutherford Laboratory, 1969
- (7) O. Bozyap and L.R. Day, Health Physics, 28, 101 (1975)
- (8) H. Ing and W.G. Cross, Health Physics, 29, 839 (1975)
- (9) F.H. Clark, N.A. Betz and J. Brown, ORNL 3926 (1967)
- (10) R.W. Roussin and F.A.R. Schmidt, Nuc. Eng. Design, 15, 319 (1971)
- (11) R.W. Roussin, R.G. Alsmiller and J. Barish, Nuc. Eng. Design 24, 250 (1973)
- (12) D. Nachtigall, "Neutron Monitoring", I.A.E.A. Vienna (1967) p 329
- (13) P.F. Sauer mann and W.L. Schäfer, "Neutron Monitoring for Radiation Protection Purposes", I.A.E.A. Vienna, (1973) p 23.
- (14) M. Heinzelmann, Health Physics, 27, 404 (1974)

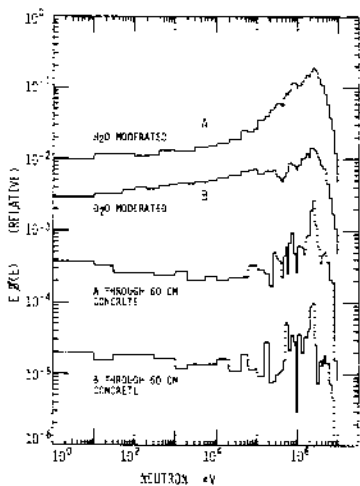

Figure 4. Spectra of neutrons from H<sub>2</sub>O and D<sub>2</sub>O reactors, before and after transmission by concrete.

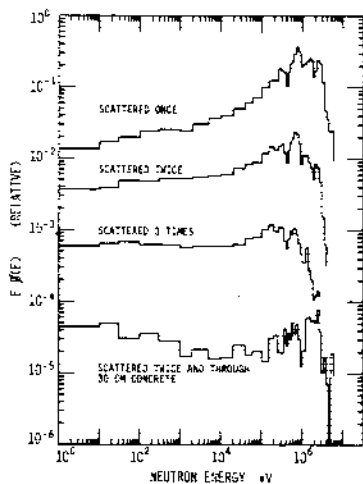

Figure 5. Spectra of fission neutrons multiply-scattered from concrete.

ABOUT THE CALCULATION OF BREMSSTRAHLUNG OUTSIDE OF ACCELERATOR BUILDINGS

D. Zappe, G. Hahn, V. Schuricht  
 Technical University Dresden, GDR

1. INTRODUCTION

In the last years in science and engineering the application of accelerators obtained increasing importance because of the growth of their capacity. In order to enlarge the capacity of an existing accelerator it is often necessary to construct shieldings around the original accelerator building. Whereas the enlargement of the thickness of the surrounding walls is not very difficult a special consideration must be given to the shielding properties of the roof. In this connection the radiation skyshine is of interest, because it is hardly possible also to enlarge the thickness of the roof. In this paper the calculation of bremsstrahlung skyshine outside of an accelerator building is described.

2. THE MODEL OF RADIATION TRANSPORT

For the calculation it was assumed that, firstly, for a distance of 1 m from the target the energy and angular distribution of the exposure rate of the arising bremsstrahlung is given according to Fig. 1 and, secondly, that the radiation is totally absorbed in the surrounding walls and is not influenced by the roof.

The geometry of the accelerator building shows Fig. 2. The points for which the exposure rate due to bremsstrahlung skyshine must be calculated are marked by  $P_1, P_2, \dots$  with the coordinates  $(x_1, x_2, \dots; y = h_2; z = 0)$ .

Calculations were carried out by means of the Monte-Carlo method. Only such photons are taken into account which are emitted by the target in direction of the roof. The number  $N_{BE}$  of histories of these photons per energy and angular interval is calculated according to

$$N_{BE} \sim \Psi_{BE} \sim \dot{I}_{BE}(E, \theta) / E \mu(E),$$

with  $\mu(E)$  as the linear energy transfer coefficient for air

and  $\varphi_{D0}$  as the flux density per energy and angular interval. Simultaneously for all points  $P_1, P_2, \dots$  the differential flux density  $\varphi_E$ , the total flux density  $\varphi$  and the total exposure rate  $X$  are calculated using well-known steps of Monte-Carlo calculations. More details of the model used are given in separate papers (3,4).

### 3. RESULTS

Some results of the Monte-Carlo calculations of bremsstrahlung exposure rate are shown in Fig. 3. A comparison between Monte-Carlo results and those bei calculation of the single scattered radiation is given in Fig. 4. Note that the Monte-Carlo method is more favourable to obtain differential quantities of the scattered bremsstrahlung and to obtain results for larger distances between accelerator building and the point of interest. The single-scattering method, on the contrary, represents a relative simple procedure to get approximative values. Variations of the criteria of history termination show that the cut-off energy should be much less than 100 keV (in these calculations 25 keV). The results of such calculations allow the determination of the maximum electron current of the accelerator for which one can ensure radiation protection outside the building.

This work was carried out in cooperation with the Joint Institute for Nuclear Research in Dubna.

### REFERENCES

- (1) TSOVBOON, V.I., Preprint P16-7104, JINR, Dubna 1973
- (2) SIFKO, G.A., Diploma Theses, JINR, Dubna 1974
- (3) ZAPPE, D., et al., TU-Informationen 05-45-75 (Dec. 1975)
- (4) ZAPPE, D., et al., TU-Informationen 05-22-76 (April 1976)
- (5) ZAPPE, D., et al., Preprint P16-9481, JINR, Dubna 1976

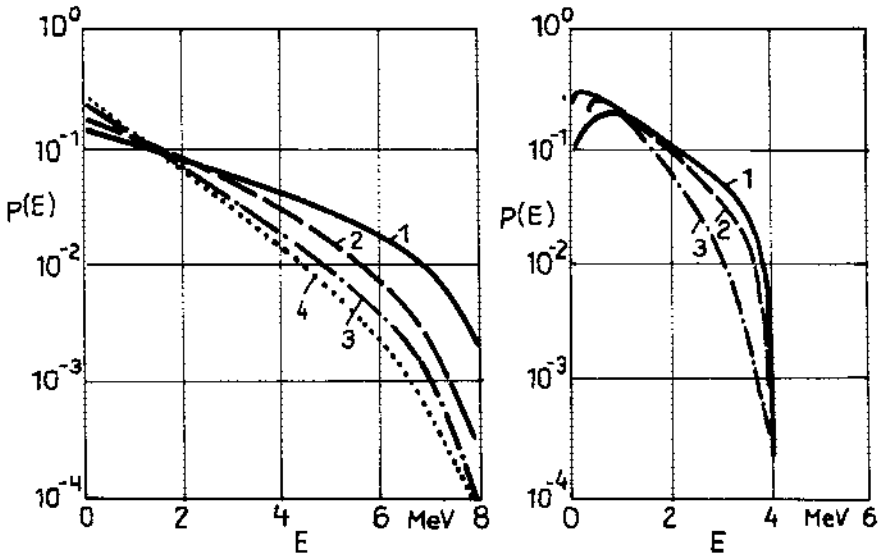

FIG. 1. Energy distribution  $p(E)$  of  $X_{30}(E,0)$  for several angles  $\theta$  between the direction of the electron beam and the arising bremsstrahlung for a distance of 1 m from the target (1,2)

a) Sn target, energy of electrons 8 MeV

- 1 -  $0^\circ \leq \theta < 20^\circ$
- 2 -  $20^\circ \leq \theta < 50^\circ$
- 3 -  $50^\circ \leq \theta < 100^\circ$
- 4 -  $100^\circ \leq \theta < 150^\circ$

b) Au target, energy of electrons 4 MeV

- 1 -  $0^\circ \leq \theta < 10^\circ$
- 2 -  $30^\circ \leq \theta < 60^\circ$
- 3 -  $120^\circ \leq \theta < 150^\circ$

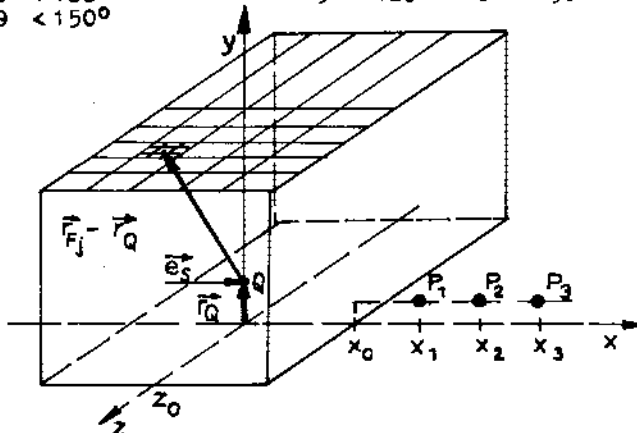

FIG. 2. Geometry of the accelerator building

$\vec{e}_s$  - direction of the electron beam  
 Q - target, source of bremsstrahlung in the height  $h_1$  (vector  $\vec{r}_Q$ )

$\vec{r}_{P_j}$  - vector to the centre of the roof square no.  $j$   
 $P_1$  - points in the height  $h_2$ , for which the exposure rate due to bremsstrahlung must be calculated

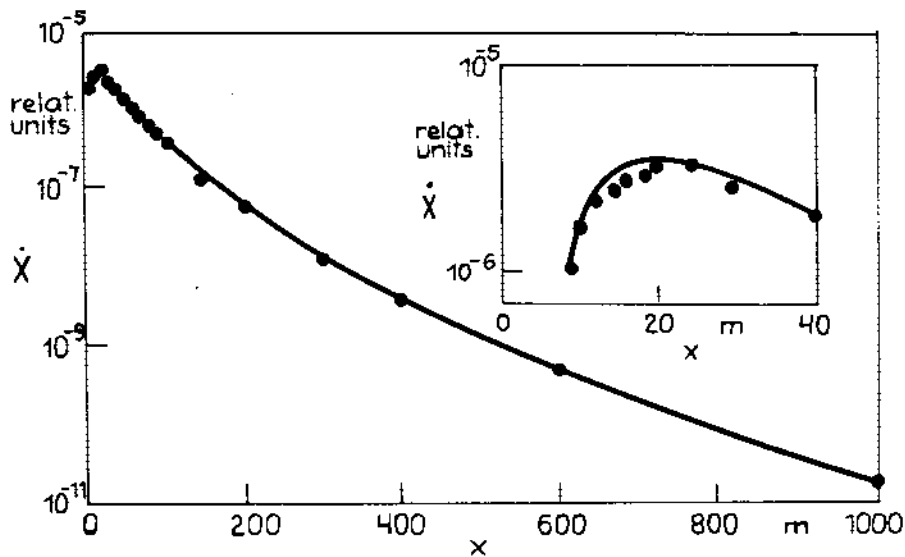

FIG. 3. Exposure rate  $\dot{X}$  at several distances  $x$  from the target Sn target, energy of electrons 8 MeV,  $h_2 = 1$  m,  $z_0 = 9$  m (3)

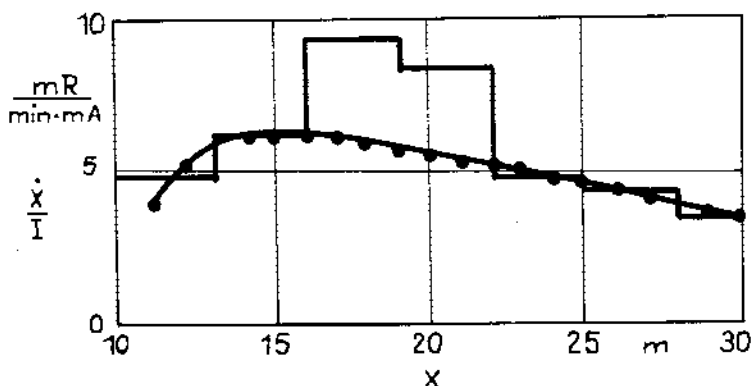

FIG. 4. Exposure rate  $\dot{X}$  per electron current  $I$  at several distances  $x$  from the target (4)

1 - results of Monte-Carlo calculations  
 2 - results of calculations of the single scattered radiation  
 Ta-W-Au target, energy of electrons 2 MeV,  $h_2 = 1$  m,  $z_0 = 25$  m

DESCRIPTION OF A METHOD OF CONTROL FOR GLASS LENSES USED AS  
A PROTECTION MEDIUM AGAINST RADIATION

J. V. Silva Alonso  
P. Pérez Torío

Centro de Higiene y Seguridad del Trabajo,  
Avda. del Faro, 15, SANTANDER, Spain.

## 1. INTRODUCTION

The need for protecting our sight against radiations has been shown on many occasions. This need is particularly obvious in the case of exposures to heat or light sources with a high intensity.

Glass protection lenses are submitted to the spectrophotometric measurement obtained in the three spectral zones: infrared, visible and ultraviolet. As it is not possible to obtain a photometric measurement nor test photometrically a very opaque sample, one must reduce the thickness of the material by destructive techniques, in order to obtain plates in which the transmission factors are at least equal to 5% in the spectral regions with maximum opacity. The values obtained by calculation can refer to any thickness of lens. In practice, these plates can only be obtained by glass manufacturers, or from highly specialized laboratories; the normal user would find it impossible to obtain them. Because of this, the control of glass protection lenses would be reduced to those with a high transparency, which are precisely those of least interest from a practical point of view.

In the present work, a method of measurement is described which permits the determination of the optical density of a glass lens, at each wavelength, by measuring successively a glass lens of a known opacity against others of increasing opacities; in this way their protection capacity can be deduced.

To finalize and check the method, glass lenses normally used for industrial protection were employed.

## 2. DEFINITIONS AND DESIGNATION

The glass lenses are classified relating the percentage of visible light transmitted and a number, N, denominated "degree of protection", using the expression:

$$N = \frac{7}{3} \log \frac{1}{T} + 1 \quad \text{or} \quad N = \frac{7}{3} D + 1$$

in which T is the average transmission in the visible band of the spectrum expressed as a fraction of 1, and  $\log 1/T$  is the optical density, D, of the lens.

TABLE 1

nm	800	750	700	650	600	550	500	450	400
1/0	116	092	070	054	042	032	032	042	050
2/0	128	102	078	064	050	044	044	058	070
(1+2)/0	244	194	148	118	090	076	076	100	120
4/0	-	-	230	176	136	122	126	160	196
5/0	-	-	280	230	176	152	156	190	210
4/(1+2)	128	108	084	062	052	048	048	056	082
4/2	240	200	154	166	090	080	080	094	128
5/2	-	262	204	164	130	110	110	130	150
5/(1+2)	202	172	134	110	090	080	080	087	100
6/2	270	228	188	186	168	156	168	200	234
5/4	076	067	053	050	040	032	030	032	020
6/4	032	032	039	071	080	080	090	104	110
7/4	102	092	090	120	128	122	134	156	166
8/4	174	154	140	166	170	152	168	190	210
6/5	-044	-036	-014	023	042	050	060	072	094
7/5	024	024	040	076	088	092	104	128	160
8/5	100	088	090	124	130	126	140	170	198
7/6	070	060	050	052	048	044	046	056	062
8/6	144	124	102	104	092	080	082	100	106
8/7	076	065	053	052	044	038	038	046	060

TABLE 2

nm	800	750	700	650	600	550	500	450	400	Steps to obtain the absolute value
1	116	092	070	054	042	032	032	042	050	(1/0)
2	128	102	078	064	050	044	044	058	070	(2/0)
4	-	-	230	176	136	122	126	160	196	(4/0)
4	368	302	232	180	140	124	124	152	198	(4/2)+(2/0)
4	372	302	232	180	142	124	124	156	202	(4/1+2)+(1+2/0)
5	-	-	280	230	176	152	156	190	210	5/0
5	-	364	282	228	180	154	154	188	220	(5/2)+(2/0)
5	446	366	282	228	180	156	156	187	220	(5/1+2)+(1+2/0)
6	398	330	266	250	218	200	212	258	304	(6/2)+(2/0)
6	-	-	269	247	216	202	216	264	306	(6/4)+(4/0)
6	-	-	266	253	218	202	216	262	304	(6/5)+(5/0)
7	-	-	320	296	264	244	260	316	362	(7/4)+(4/0)
7	470	394	322	300	268	246	258	308	364	(7/4)+(4/2)+(2/0)
7	-	-	320	306	264	244	260	318	370	(7/5)+(5/0)
7	-	388	322	304	268	246	258	316	380	(7/5)+(5/2)+(2/0)
7	468	390	316	302	266	244	258	314	366	(7/6)+(6/2)+(2/0)
7	-	-	319	299	264	246	262	320	368	(7/6)+(6/4)+(4/0)
8	542	456	372	346	310	276	292	342	408	(8/4)+(4/2)+(2/0)
8	-	452	372	352	310	280	294	358	418	(8/5)+(5/2)+(2/0)
8	542	454	368	354	310	280	294	358	410	(8/6)+(6/2)+(2/0)

Optical density x 100



### 3. EXPERIMENTAL

#### 3.1. Material:

The spectrophotometric measurements have been obtained with a BECKMAN spectrophotometer, ACTA C III model, adjusting the power to each wavelength in which the measurement was made, quick answer time, with the digital calibrated for three absorbancy units.

The lenses used, in increasing opacity, were supplied by various commercial firms.

#### 3.2. Measurement technique used:

As the optical density is an additive magnitude, it is possible to carry out the determination step by step. A glass lens with a high opacity, whose photometric measurement cannot be made directly because of the aforementioned obstacles, can be made, nevertheless, with a very simple device. If one mounts the lens to be measured in the measuring beam, and one places another less opaque lens in the beam of reference, the value obtained will be the difference of their optical densities in that wavelength.

So, if one uses a lens of a known density and a series of lenses with an increasing opacity, between the opacity of the known lens and that of the lens to be measured, the density of this lens can be measured, applying the method of successive steps, according to the sequence:

$$D_C = D_{C/B} + D_{B/A} + D_{A/O}$$

$D_{B/A}$  = Difference between the optical densities of the A and B lenses.

The number of intermediate steps will depend on the nature of the lens to be studied and on the glass family available.

#### 3.3. Experimental Results:

The optical density values obtained at different wavelengths for the families of lenses studied are shown in Table 1. In each case, the lenses used for the determination are indicated by two numbers separated by a line. In the upper half the degree of protection of the lens placed in the sample department (S) is shown, and in the lower half, of the lens placed in the beam of reference (R). "/O" indicates that in the corresponding department no lens was placed.

In the following Table, number 2, the optical densities for the different wavelengths have been resumed and arranged; these were calculated by the technique of successive steps. The step sequence followed is shown in the third column.

#### 4. DISCUSSION OF THE RESULTS OBTAINED AND CONCLUSIONES:

- 4.1. Following the method described in the preceding paragraphs, the optical density of any lense at any wavelength can be obtained, and therefore it is possible to identify the characteristic absorption curve of the lense to be studied by a non-destructive method.
- 4.2. The results we obtained are independent of the intermediate lenses used, providing that the difference in the optical density between the lenses placed in the sample beam (S) and the reference beam (R) are maintained below a certain value, which will be conditioned by the characteristics of the spectrophotometer used.
- 4.3. The consistency in the results which were obtained indicates a high precision, since the small differences observed in some cases are within experimental error.
- 4.4. The application of the successive steps method which we propose, permits the examination of a material which is going to be used for protection in a certain industrial operation to see if it complies with the minimum requirements demanded by the different international standards.

-

## UN NOUVEAU SYSTEME DE FIXATION ET DE REMPLACEMENT POUR LES BOÎTES À GANTS

H. Fluhr, Bau - M. Ohlmeyer, PTA - E. Windbühl, ASS Gesellschaft für Kernforschung, Postfach 3640, D-7500 Karlsruhe

### 1. INTRODUCTION

Les boîtes à gants servent à manipuler et à traiter des substances dangereuses moyennant des gants installés à l'extérieur et passant par des ouvertures à l'intérieur de la cage. Ces substances peuvent avoir des propriétés toxiques, radioactives et/ou pyrophores. Evidemment, le travail sans risque aux boîtes à gants implique que tous les pièces et joints présentent une excellente qualité, même pour de longues périodes de service et de vie. Les points faibles sont notamment la position de fixation des gants et des sacs en plastique ainsi que la technique de remplacement nécessaire à l'opération.

Ces points faibles et les risques qui en résultent pour la fixation et l'étanchéité ainsi que pour la technique de remplacement y associée ont été reconnus très tôt en technique nucléaire en ce qui concerne les systèmes de filtration de l'air d'échappement. Ils pouvaient être éliminés par des modifications constructives de la fixation et l'adaptation de la technique de remplacement [1,2]. Il est montré dans cet exposé comment le système de fixation et de remplacement, qui a fait ses preuves des milliers de fois, fut transmis aux boîtes à gants [3,4].

### 2. SYSTEME ANTERIEUR DE FIXATION ET DE REMPLACEMENT

La diversité des méthodes de fixation connues fait comprendre à l'observateur critique que nulle version garantit la fixation sûre et le joint étanche. Pendant la période de service souvent très longue ce ne sont pas seulement les éléments d'obturation qui vieillissent mais également les gants eux-mêmes, notamment aux plis très aiguës sur les manchons souffrant le plus d'usure et pour cette raison les gants doivent être remplacés. Les éléments d'obturation faillissent fréquemment au cours du remplacement et sont complètement détruits.

Ceci montre qu'il faut s'accommoder de risques de sécurité considérables pour les phases de fonctionnement et de changement. L'importance que les fabricants et les exploitants attribuent à la sécurité se traduit également par la réalisation très stable des joints entre les boîtes à gants, p. ex. en tuyaux inox. La stabilité de ces joints n'est aucunement proportionnée aux risques liés aux fixations insuffisantes des gants utilisées dans le passé.

### 3. FONCTIONNEMENT DU NOUVEAU PROFIL DU COLLET

Le nouveau profil du collet tiré de la technique de filtrage remplit les exigences d'une fixation et obturation parfaites et sûres [6].

Contrairement aux anciennes méthodes d'obtenir l'étanchéité, la forme du profil du collet a été modifiée de sorte que le serrage et l'étanchéité nécessaires du gant ne dépendent plus de la tension longitudinale de l'anneau d'étanchéité, accélérant l'usure, mais qu'ils agissent sur la section de l'anneau d'étanchéité lui-même. L'anneau d'étanchéité est pressé dans la rainure du collet de manière à ce que la tension de l'anneau agisse dans le sens rectangulaire par rapport au profil du collet. Lorsqu'une force de traction est appliquée sur le gant, celle-ci produit un effet d'arrêt automatique sur l'anneau puisque cette force presse l'anneau d'étanchéité contre l'étranglement supérieur du profil du collet ce qui entraîne une augmentation de la pression de serrage. L'anneau d'étanchéité ne souffre plus d'une usure prématurée à cause de l'absence de la tension longitudinale.

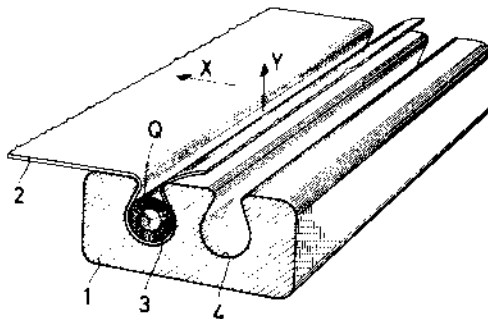

Figure 1

Représentation du fonctionnement du nouveau profil du collet [5]. L'étanchéité entre le profil 1) et le sac en plastique respectivement le gant 2) est réalisée par le serrage uniforme du profil en caoutchouc 3) dans la rainure 4), indépendamment de la forme longitudinale du profil, entraînant l'étanchéité de la parois de la rainure par l'action de la tension transversale "Q". La sollicitation du gant dans la direction de "X" déplace le profil en caoutchouc en direction "Y" et augmente la force de serrage par blocage automatique.

#### 4. EMPLOI DU PROFIL DU COLLET POUR LA FIXATION ET L'OBTURATION

Avec la position couramment utilisée des rainures sur la face extérieure du manchon les points d'usure décrits se situant sur le front du manchon respectivement sur ses bords déterminent essentiellement la durée de vie des gants. Par contre, la position de la rainure d'étanchéité ne joue plus de rôle dans le cas du profil de rainure proposé ici en ce qui concerne la qualité de l'étanchéité.

Ceci implique que les deux rainures d'étanchéité sont disposées sur la face intérieure du manchon ce qui élimine parfaitement les points d'usure susmentionnés. De plus, la surface de contamination est réduite sur les manchons et se trouve maintenant dans la zone du manchon où, dans le cas éventuel d'une fuite se produisant dans le gant, le courant d'air est dirigé vers l'intérieur. Ainsi, la technique de remplacement de gants respectivement de récipients en feuille en plastique peut être considérablement améliorée. Une rainure supplémentaire employée dans la version simple antérieure ne sert qu'à la fixation des gants et n'a aucune importance pour le remplacement et l'étanchéité.

#### 5. TECHNIQUE DE REMPLACEMENT AVEC LE NOUVEAU PROFIL

Avec les dispositions couramment employées jusqu'ici, il y avait des difficultés, notamment au cours du changement des gants, parce que les rainures étaient placées à la face extérieure et que les gants manquaient de transparence. Avec la nouvelle disposition les manipulations principales de changement se font par le gant avoisiné et peuvent être observées sans entraves. Les problèmes à résoudre en sus qui ressortissent du rayon petit du manchon et la faible élasticité du matériel de gant sont éliminés par des rainures placées à la face intérieure du manchon.

En outre, le risque que courent les opérateurs pendant le changement est considérablement réduit par l'élimination des bords, c.à.d. des points très critiques.

La partie contaminée du manchon se limite à la face intérieure et, dans le cas de défauts, elle se trouve donc clairement dans le courant d'air dirigé vers l'intérieur.

La nouvelle conception présentée dans cet exposé a été employée avec succès auprès de la GfK.

#### Resumé:

En ce qui concerne les boîtes à gants la sécurité des opérateurs et de l'environnement dépend essentiellement de la qualité du joint posé entre le gant et la boîte à gants. Ce joints doit être étanche au gaz et doit avoir une bonne résistance mécanique accompagnée d'une durée de vie très longue. De plus, les gants doivent être remplacés de manière simple et non-dangereuse.

Un système de fixation et de remplacement éprouvé depuis longtemps en technologie de filtration fut transmis à la technique des boîtes à gants. Des travaux de mise au point et de modification ont permis de tenir compte des conditions spéciales s'appliquant aux boîtes à gants. Le nouveau système de fixation et de remplacement prolonge décisivement la durée de vie des gants tout en améliorant l'étanchéité et la fixation, par le fait qu'il déplace les zones critiques d'usure vers l'extérieur de l'obturation. Les gants sont changés de façon plus sûre et simple à l'aide du nouveau système.

### Literatur

- [1] Ohlmeyer, M.: Verbesserung der Kunststoffstoffsackabdichtung an Luftfiltergehäusen und der Filterwechsellmethode bei Luftfiltern, die zur Abscheidung gesundheitsschädlicher Stoffe dienen, Klimatechnik, 9 (1967), Nr. 7, 14; Nr. 8, 16
- [2] Ohlmeyer, M. Stotz, W.: Schwebstoff-Filteranlagen für die Abluft aus kerntechnischen Einrichtungen. Kerntechnik, 15 (1973) Nr. 9, 416
- [3] P. Berliner, M. Ohlmeyer, W. Stotz: The Nuclear Karlsruhe Air Filter System, IAEA-International Symposium on the Design of and Equipment for Hot Laboratories-Helsinki Aug. 1976
- [4] Contrôle In Situ des filtres Absolus du système de Filtration "Nuclear Karlsruhe". Séminaire sur la filtration absolue des Aerosols, Aix-en-Provence Nov. 76
- [5] Firmenschrift der Pedrolit GmbH, Zürich: Tante Pedi, April 1972
- [6] E. Windbühl, M. Ohlmeyer: Mehr Sicherheit bei der Arbeit an Handschuhkästen durch Verbesserung der Handschuhbefestigung. Kerntechnik 2 (1976) 85, 89.

## DETERMINATION OF SKIN DOSE TO THE HANDS OF TECHNOLOGISTS HANDLING SYRINGES CONTAINING RADIOPHARMACEUTICALS

AMITABH TRIPATHI

Radiation Center, Oregon State University, Corvallis, OR 97331 USA

### INTRODUCTION

In recent years, the use of various radionuclides in nuclear medicine has increased significantly. Technetium-99m is most widely used for gamma imaging of brain, liver, thyroid and kidney. Most often technologists use  $^{99m}\text{Tc}$  radioactive solution in unshielded syringes for diagnostic and therapeutic injections(1). It is important to know accurate dose delivered to the hands of technologists, who handle  $^{99m}\text{Tc}$  in syringe, in order to confirm that exposure is within safe limits. The ring and wrist monitors using films and thermoluminescent dosimeters (TLD) do not adequately reflect true radiation burden to the hands (2).

Previous investigations of skin doses have been performed using TLD or films(3,4). The response of TLD or film has been determined in these investigations by measuring the dosimeter's response to pure gamma fluxes. However, in reality the dosimeters are in a mixed flux of photons and particulates including secondary electrons. The darkening of the film and the excitation of the TLD per unit dose is higher from electrons than it is from photons. Therefore by analyzing the dosimeter's response with pure gamma calibration curves may cause underestimation of actual absorbed dose. Henson's (5) results confirm that the skin dose in contact with unshielded syringes is higher than TLD or film measurements, even when he makes no allowance for the dose arising from secondary electrons.

It is the purpose of this paper to evaluate the risk involved in handling unshielded syringes containing  $^{99m}\text{Tc}$ , by providing the results of the calculations which determine dose from photons and particulates as a function of depth in the skin. Also, an estimate of possible hand dose received by the technologists using unshielded syringes has been made on a yearly basis.

### METHOD OF CALCULATION

A Monte Carlo computer program(6) was developed to calculate dose rates at surface sites on syringes containing  $^{99m}\text{Tc}$ . The calculations include dose due to characteristic x rays, gamma rays and beta particles, including the secondary electrons generated in the syringe wall, and make allowances for absorption in the source and syringe wall. In order to simplify the calculations, the geometry of syringe-barrel was considered as a right circular cylinder and water was taken as tissue-equivalent

material. A photon cut off energy of 2 keV was introduced, assuming local absorption of photons below 2 keV. The system defined in Monte Carlo dose calculations consisted of the radioactive fluid, plastic syringe wall and the skin-tissue surrounding the syringe. The disintegration of one  $^{99m}\text{Tc}$  atom and absorption of its energies was defined as a history. About 75,000 to 100,000 histories were obtained to get a good estimate of absorbed dose. Due to statistical nature of the problem, errors were upto  $\pm 10$  percent.

The calculations were performed for commercially available, disposable type, one and five milliliter plastic syringes, filled with 1ml and 5 ml radioactive fluid respectively. The inside radii of the syringes were 2.3 mm and 6.4 mm respectively, and the wall thickness was 0.8mm. The chosen sites in the skin varied from 10 micrometer to 10 centimeter radially in the skin, over various locations on the active volume.

#### DISCUSSION OF RESULTS

Results of the Monte Carlo dose calculations for 1 and 5 ml syringes are given in Table 1. Doses at the surface of syringes are extremely high, of the order of  $10^5$  mrad/mCi-minute, due to very large dose-contribution from the secondary electrons. Doses due to the secondary electrons drop off rapidly within 0.02 mm away from the surface.

TABLE 1. Radial Dose Distribution for 1ml and 5ml Syringes

Distance from the syringe-surface(cm)	Dose Rate (mrads/mCi-minute)	
	1 ml Syringe	5 ml Syringe
At the surface	$6.25 \times 10^5$	$4.2 \times 10^5$
0.02	60.5	22.0
0.04	45.1	15.3
0.10	31.4	9.7
0.25	15.6	7.0
0.50	10.0	5.3
1.0	5.7	3.1
2.0	2.8	1.8
3.0	1.6	1.0
4.5	1.25	0.6
6.0	0.57	0.3
8.0	0.36	0.19
10.0	0.15	0.10

The axial dose, at various locations over the active volume, does not vary significantly, however, it is peaked at the center of the active



volume.

The plot of radial dose rate is shown in Figure 1. It is important to note that the skin dose to the active layer of the skin, few hundred micrometers deep, is only 20-30 mrad/mCi-minute for five milliliter syringes and 35-68 mrad/mCi-minute for one milliliter syringes.

The surface dose to the active layer of skin are compared with the published results in Table 2. The results in publications vary because of differences in syringe dimensions, types of syringes used, and the amount and activity of radioactive fluid in the syringe. As shown in Table 2, the calculated results, both Henson's and the Monte Carlo, are higher than the measured dose.

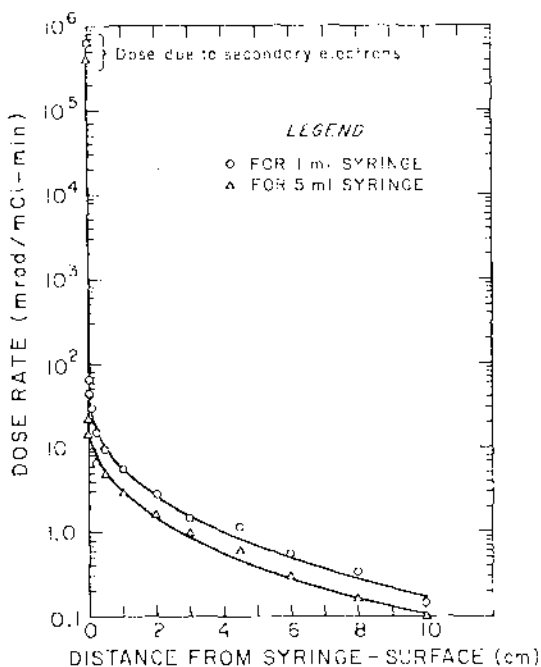

FIGURE 1. Plot of the Radial Dose Distribution

TABLE 2. Comparison of Available Results

Source of Data	Surface Dose Rate <sup>1</sup>	Reference
NIE film measurement		(2)
1 ml syringe	14-20	
6 ml syringe	15-25	
Husak, TLD measurement		(4)
6 ml syringe	9	
Henson's calculations		(5)
1 ml syringe	25-55	
5 ml syringe	15-20	
Monte Carlo Calculations		(6)
1 ml syringe	35-68	
5 ml syringe	20-30	

<sup>1</sup> dose rate in mrad/mCi-minute

## CONCLUSION

The calculated surface dose from a  $^{99m}\text{Tc}$  filled syringe to the active skin layer is about 3-6 times higher than TLD and film measurements. Thus, a technologist can receive 100-300 mrad/year by performing 25 administrations per week of 10 mCi activity each, when the average administration time is 0.4 minute. This dose is 1.3-4 times higher than the permissible occupational hand dose set by the United States Nuclear Regulatory Commission. The appropriate design and use of syringe shields are essential to avoid the undesirable effect of excessive and unnecessary radiation exposure.

## REFERENCES

- (1) Lombardi, M. H., Beck, W. L. and Cloutier, R. J., "Survey of Radiopharmaceutical Use and Safety in Sixty-Nine Hospitals," DHEW Publication(FDA)73-8029, U. S. Dept. of Health, Education and Welfare Publication. Washington, D.C. (1973).
- (2) Howley, J., "Radiation Safety in Nuclear Medicine," National Institute of Health, Maryland, to be published.
- (3) Neil, C. M., "The Question of Radiation Exposure to the hand from Handling  $^{99m}\text{Tc}$ ," Journal of Nuclear Medicine, no 10, pp 732-734 (1969).
- (4) Husak, V., "Exposure Rate at the Surface of Syringe containing Radioactive Material," Journal of Nuclear Medicine, v. 12, pp 574-575 (1971).
- (5) Henson, P. W., "Radiation Dose to the Skin in Contact with Unshielded Syringes Containing Radioactive Substances," British Journal of Radiology, v. 46, pp 972-977 (1973).
- (6) Tripathi, A., "Absorbed Dose on Syringe Surface from Photon and Particulate Radiations Emitted by  $^{99m}\text{Tc}$ ," M.S. Thesis, Howard University, Washington, D.C. (1976).

PROBLEMS OF DIFFERENTIAL DIAGNOSIS IN EVALUATION OF  
PATHOLOGICAL EFFECTS OF IONIZING RADIATION IN MEDICAL  
SUPERVISION OF OCCUPATIONALLY EXPOSED PERSONS

D.Stojanović, D.Valjković, B.Aleksić and Z.Djukić

Medical Protection Laboratory of the Boris Kidrič  
Institute of Nuclear Sciences, Vinča-Belgrade,  
Yugoslavia

## 1. INTRODUCTION

This report considers the possibilities of using the results of medical supervision of physicians and other medical personnel occupationally exposed to ionizing radiation at appliance of diagnostic X-Rays in period to ten years. Following the accepted criteria of the critical organs for total body irradiation /1/, our examination included the majority of these critical organs. The aim of the medical supervision was to define the criteria for evaluation of radiation effects in conditions of the occupational exposition and evaluation of magnitude of risk.

## 2. METHODS

The control of working conditions and state of health of personnel occupationally exposed to ionizing radiation included the radiation doses at X-ray apparatus, the doses at working place of medical personnel measured on different parts of the body, the doses in different medicine interventions, film-badge control with Kodak RM film on chest or hand and health control. All the supervision were carried out on 148 persons chronically exposed to diagnostic X-Rays of different intensities and for various period of time. Observations were selected according to occupation, sex, character of exposition, film badges data of received doses and to the physiological radiosensitive systems. Health checkup are included a general clinical examination against systems/skin, eyes, cardiovascular, nervous and endocrine system and other, biochemical analyses at larger number of persons and haematologic control.

The haematologic examinations included quantitative changes of total leucocyte counts, differential blood picture, incidence of cytomorphologic changes in white cells of peripheral blood, haemoglobine, haematocyte, time of coagulation and bleeding.

### 3. RESULTS AND DISCUSSION

Examinations were carried out against the occupation and sex is given in table 1.

Occupation	S e x		Total
	Female	Male	
Radiologists	2	6	8
Phtisiologists	3	7	10
Surgeons (orthopae- dists, urologists)	3	24	27
Physicians	-	15	15
Stomatologists	7	13	20
Roentgen technicians	18	26	44
Medical persons	14	10	24
Supervised total:	47	101	148

TABLE 1 Number of the supervised persons.

The observed changes, deviations and diseases of the supervised persons in dependance of working exposition is given in table 2.

Working exposure (years)	N	Skin	Haematologic changes		
			Numerical	Morphologic	Eyes
1 - 5	50	14	5	5	1
6 - 10	31	5	8	8	1
11 - 15	34	26	19	5	2
16 - 20	16	5	6	3	1
under 20	17	2	4	1	-

TABLE 2 The observed changes of the supervised persons.

The most expressive changes of the skin, as well as the haematologic changes at supervised persons have been found. The most apparent changes of the skin have been observed in the group of roentgen technicians who were working more than ten years and at radiologists. The changes of the skin include the following states: dry skin, capillares teleangiectatic, superficial vessels, nail changes with brittleness, splitting and longitudinal ridging, onychia and paronychia, reduction of hair follows, hyperkeratosis, greater sensitivity of the skin on external irritant agents, separately on mechanical and thermal action, and residua of postradiodermatitis. In differential diagnosis a series of pathological states and diseases of the skin should be taken into account. The states found at some smaller number of persons as residua from an earlier radiodermatitis show that anatomic location of changes relating on dorsal and volar side of the hand, location on single fingers,

explain that some changes occurred when the measures of prevention were inadequate. At majority of the supervised persons, the described changes were not brought to the brake of their work. The classic type of the acute radiodermatitis has not been described. The dependence on manner of work influences on location of changes.

Analysis of the numerical values have shown that about 30% of the examined persons expresses a deviation from the allowed haematologic norms for work with ionizing radiation. These deviations are reflected in higher values of total leucocytes, arrived by increased number of neutrophiles, while the lymphocytosis of relative type and were reflected in the increasing of per cent from 40 to 50. Lymphopenia was rarely observed. From morphologic changes have been observed the appearances of young forms of leucocytes to promyelocytes, fragmentation of nucleus and binuclear and bilobar lymphocytes.

Against order of iteration the appearances of some states and diseases at all controlled persons occurred as most registered focuses: Pharyngitis chr., Caries, Bronchitis chr., Sinusitis and other. Criteria for evaluation of some diseases are very different in praxis.

For analysis of numerical and morphological variations could be of some significance for differential diagnosis: national haematologic standardization, influence of the race, exposition to the harmful agents as well as use of alcohol, smoking, data about diseases in the past, periodical or permanent use of some drugs, which can influence on haematologic reaction and so on. The greatest significance is also to recognize the time of keeping of some haematologic changes. A separate regard to the existence of the young cells in peripheral blood, when correlated with anaemia and other changes, or as prestates in correlation with other clinical and laboratory findings, requires indispensable evaluation of the risk of malignancy.

In occurrence of cataract affected, the ionizing radiation was considered as very important cofactor. These appearances are most numerous on posterior pole of lens. For differentiation of lenticular opacities of radiation origin in relation to congenital origin, the problem of progress is most important.

Low rules and regulations very often do not include evaluation of capability for work with ionizing radiation at post infarctus states, insufficiency of hearth, different states of insufficiency of endocrine system (hypoglycaemia and diabetes mellitus, hyperthyreosis), syndrome neurotic, depressive states and other, what presents a special problem in routine medical supervision.

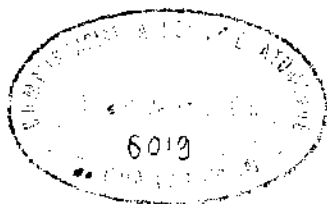

The use of radiation protection measures and regular medical supervision present the most constructive prevention of harmful radiation effects, what means that the majority of data were in normal limits.

Of course, that on appearance of damages an early diagnosis and appliance of all protection measures primary influences the organization of radiation protection with technical and medical supervision.

#### REFERENCES

- (1) NORWOOD, M.D., THOMAS C.Ch., Medical supervision of radiation workers, Publisher Springfield-Illinois-USA (1975).
- (2) GUSKOVA, A.K. et al. Third European Congress IRPA, Amsterdam (1975).

## THE DISTRIBUTION OF PLUTONIUM-239 IN THE SKELETON OF THE MOUSE

D. Green, G.R. Howells, M.C. Thorne and J. Vennart  
 NRC Radiocology Unit,  
 Harwell, Didcot, Oxon. OX1 0RD, U.K.

## 1. INTRODUCTION

It is well known that plutonium-239 is primarily deposited on the endosteal surfaces of cortical and trabecular bone and that after deposition it may either be resorbed, entering the reticuloendothelial system and blood, or buried under newly deposited bone mineral (1). However, the kinetics of these processes are not well understood. Such an understanding is of considerable importance in the field of radiological protection, since a knowledge of the detailed distribution of plutonium-239 in bone and its variation with time is necessary for the calculation of dose rates to those tissues thought to be at risk with respect to tumour induction (2), namely osteoprogenitor cells close to the endosteal surfaces of mineral bone and haematopoietic bone marrow (3).

In this paper we present some results from a detailed study of the distribution and retention of plutonium-239 in female CBA mice. This study which will cover the period 1 day to 18 months post-injection, is not yet complete and in this paper we present results only for animals killed at 24 hours post-injection. These results include radiochemical analyses of various bones together with analyses of the distribution of plutonium-239 in the central lumbar vertebra, a caudal vertebra and the ilium of each individual animal.

For the distribution studies we have used neutron induced autoradiography (4) together with computer based methods of data reduction. These techniques, which have been described in detail elsewhere (5), have allowed us to locate plutonium-239 with respect to bone surfaces with an accuracy of approximately  $\pm 2\mu\text{m}$ .

It must be emphasised that these studies are of particular interest not only because of the information they should yield concerning the kinetics of plutonium-239 translocation in the skeleton but also because they should help with the interpretation of experiments on tumour induction performed in our laboratory (6) and elsewhere.

## 2. METHODS

Twelve week old female CBA mice were injected intravenously with  $50\text{mCi kg}^{-1}$  of plutonium-239-nitrate at pH 4.5 and killed 24 hours later by exsanguination under chloroform anaesthesia. The bones to be analysed were then dissected out and, without prior decalcification processed through increasing concentrations of acetone and water prior to impregnation and embedding in resin. The embedded bone specimens were sectioned on a heavy-duty Jung microtome. The  $5\mu\text{m}$  sections thus produced were floated off the knife, removed to a 60°C water bath to facilitate flattening and then to a 0.75mm Lexan (polycarbonate plastic) slide. The section was sandwiched between this lexan slide and a second, similar, one. This assembly was held together with spring clips and dried at 60°C.

Lexan-bone preparations, prepared as described above, were sandwiched together in small packs and irradiated in a nuclear reactor at a neutron fluence of  $10^6$  n cm<sup>-2</sup>. The cadmium ratio of the neutron spectrum was 24, implying that more than 95% of the neutrons had energies of less than 0.5eV (7).

Following neutron irradiation the preparations were carefully separated and etched in 28% NaOH at 60°C for 75 minutes. The etched slides were then washed in tap water, rinsed in distilled water and air dried.

Neutron irradiation as described above induces two effects in the Lexan-bone preparations:

- a plutonium-239 atoms in the section are fissioned by the neutrons and some of the fission fragments enter the Lexan producing damage tracks which can be etched out by NaOH
- b the neutrons interact with the mineral bone in the section to produce an image of it in the Lexan. The mechanisms governing this process are still obscure although ( $n, \alpha$ ) reactions may be implicated.

Examples of the high contrast bone images we are now obtaining routinely have been published elsewhere (5).

In order to obtain quantitative information from these bone and track images it is necessary to reduce the data contained in them to a numerical form. This we have done by analysing photographs of these images on D-MAC tables at the Rutherford Laboratory, Oxfordshire. These tables, normally used for the analysis of particle track photographs produced in high energy physics experiments, display a magnified image of the photographic negative ( $\sim 500\mu$  x 35 cm). The co-ordinates of any point on this image can be transferred to a magnetic tape by the movement of a cursor to the point of interest followed by a foot-pedal initiated data transfer. Additional information such as frame numbers and editing commands can be entered onto the tape from an alphanumeric keyboard.

Using these tables the edges of the bone image were digitised at intervals of about 1 $\mu$ m, corresponding to about 20 $\mu$ m on the original section. The co-ordinates of the ends of the fission fragment tracks were also digitised. It should be noted that no attempt was made to distinguish which end of a track represented its point of entry into the Lexan and that in the subsequent analysis both ends of each track were processed identically.

The magnetic tapes produced during digitisation were analysed on the IBM 370 computer at A.E.R.E. Harwell using programs developed by the authors. The primary purpose of these programs was to compute the quantities shown in figure 1, the perpendicular distances of track-ends from the bone image edge ( $X_1$  and  $X_2$ ) and the angle of inclination of the tracks with respect to that edge ( $\theta$ ). Measurement of this angle of inclination was useful, since tracks parallel to the bone image edge defined the perpendicular distance of their originating plutonium-239 atom from that edge more accurately than did tracks perpendicular to it. The greater significance of tracks parallel to the bone image edge was taken account of in the analysis by assigning a weight of  $\cos^2\theta$  to each track-end when determining the distribution of track-ends about the bone image edge.



### 3. RESULTS

Figure 2 shows the distribution of weighted track-ends about the endosteal surfaces of the central lumbar vertebra at 24 hours post-injection. This distribution is centred close to the endosteal surface and the bulk of it lies within  $\pm 15\mu\text{m}$  of that surface. However, this distribution is broader than the plutonium-239 distribution which gave rise to it, because of the finite distance the fission fragments travel in the section before entering the Lexan and because of the finite distance they travel in the Lexan before stopping. In order to correct for these effects a simple deconvolution analysis has been used.

The distribution of plutonium-239 about the bone image edge is approximated by 99 equally spaced planes,  $1\mu\text{m}$  apart, parallel to the bone image edge and perpendicular to the plane of sectioning. The plutonium-239 concentration ( $p_n$ ) associated with the  $n$ 'th of these planes is proportional to the fraction of plutonium-239 between  $n-50.5$  and  $n-49.5\mu\text{m}$  from the bone image edge, negative distances lying within the bone image. Similarly, the fraction of the weighted track end distribution between  $m-50.5$  and  $m-49.5\mu\text{m}$  from the bone image edge is defined as  $t_m$ . The quantities  $p_n$  and  $t_m$  are related by;

$$t_m = \sum_n a_{mn} p_n / \sum_n p_n \quad (1)$$

where  $a_{mn}$  is the fraction of the weighted track-end distribution arising from  $p_n$  that lies between  $m-50.5$  and  $m-49.5\mu\text{m}$  from the bone image edge. Since the thickness of the specimen and the range of the fission fragments in bone and Lexan are known,  $a_{mn}$  can be calculated for all values of  $m$  and  $n$  by computer based monte-carlo procedures.

Eqn. 1 can be expressed more concisely as;

$$\underline{T} = \underline{A} \underline{P} / \sum_n p_n \quad (2)$$

where  $\underline{T}$  and  $\underline{P}$  are 99 component vectors (i.e. both  $m$  and  $n$  range between 1 and 99) and  $\underline{A}$  is a 99 x 99 element square matrix. Thus, from Eqn. 2;

$$\underline{P} / \sum_n p_n = \underline{A}^{-1} \underline{T} \quad (3)$$

The matrix  $\underline{A}$  is, therefore, determined using monte-carlo procedures, inverted using sub-routine MA21B from the Harwell Sub-routine Library and multiplied by the observed track-end distribution to generate the plutonium-239 distribution which gave rise to it.

Results of this deconvolution analysis are shown in figures 3 and 4 for the 3 bones analysed so far. In figure 3 the distribution of plutonium-239 about the endosteal surfaces of these bones is shown. In the ilium the bulk of the plutonium-239 is very closely associated with the endosteal surfaces, whereas in the lumbar and caudal vertebrae there appears to be considerably more penetration of the plutonium-239 into the bone. This latter result is in general agreement with qualitative autoradiographic studies using plutonium-241 which show a rather broad distribution of plutonium in rat and hamster bone at early times post-injection together with significant uptake by osteogenic cells close to bone surfaces (N. Priest, *Int. J. Radiat. Biol.*, in the press).

The narrowness of the plutonium-239 distribution about the endosteal surfaces of the ilium may be correlated with the gross morphology of the bone. The ilium contains a higher proportion of the cortical bone than do the lumbar and caudal vertebrae and this type of bone may be more difficult for the plutonium atoms to penetrate. Further analysis of the data so far obtained is being undertaken in order to check this possibility.

In contrast, figure 4 shows that the periosteal distribution of plutonium-239 is very similar in all three bones, suggesting that periosteal deposition is not strongly influenced by the type of bone under consideration. However, although the microscopic distribution is very similar in all three cases the concentration of track-ends associated with periosteal edges ( $\tau_1$ ) is much higher in the caudal vertebra than it is in the other two bones (Table 1). Further, the concentration of track-ends associated with endosteal edges ( $\tau_2$ ) is much lower in the caudal vertebra than it is in the other two bones (Table 1). These remarks, applying to observed bone image edges also apply, in three-dimensions, to the periosteal and endosteal surfaces of the bones. The two effects described above may be explained on the hypothesis that the blood supply to marrow is lower in the caudal vertebra than in the other two bones and that the periosteal blood supply is increased. This hypothesis is plausible, since it has been established that in mouse femur gross plutonium-239 deposition in various parts of the bone is well correlated with total blood flow in those regions (8).

In summary, a very satisfactory method has been developed for determining the distribution of plutonium-239 about bone surfaces. Results obtained so far indicate that plutonium is deposited primarily upon the endosteal surfaces of mineral bone, but not in a thin layer, there being considerable penetration of the mineral matrix probably via the lacunae even at 24 hours post-injection. Further, it has been demonstrated that the distribution of plutonium-239 about periosteal surfaces is, other than in absolute magnitude, rather independent of the bone considered. This indicates that factors such as blood supply are probably more important in governing the periosteal deposition of plutonium than is the detailed local structure of the periosteal surface.

#### REFERENCES

- (1) VAUGHAN, J. in "Handbook of Experimental Pharmacology, 36, Uranium, Plutonium, Transplutonic Elements" Berlin, Springer Verlag pp 400-413 (1973)
- (2) THORNE, M.C. Nature, Lond. 259 (1976) 539
- (3) ICRP Publication 11 "A review of the radiosensitivity of the tissues in bone, Pergamon, Oxford (1968)
- (4) JEE, W.S.S. "Plutonium-239 in bones as visualised by photographic and neutron-induced autoradiography" in Radiobiology of Plutonium (Stover, R.J. and Jee, W.S.S. Eds) J.W. Press, Salt Lake City, Utah (1972)
- (5) GREEN, D., HOWELLS, G., THORNE, M.C. "A new method for the accurate localisation of plutonium-239 in bone", Phys. Med. Biol. (in the press)
- (6) LOUTIT, J.F., SANSON, Janet, CARR, T.E.F. "The pathology of tumours induced in Harwell mice by plutonium-239 and radium-226" in "The Health Effects of Plutonium and Radium" (Jee, W.S.S. Ed) J.W. Press, Salt Lake City, Utah (1976)
- (7) IAEA "Neutron Fluence Measurements", STI/DOC/10/107 (Vienna, IAEA) pp 47-49 (1970)
- (8) HUMPHREYS, E.R., FISHER, G. and THORNE, M.C. "The measurement of blood flow in mouse femur and its correlation with plutonium-239 deposition" (submitted to Calcified Tissue Research)

Bone	f	t <sub>1</sub>	t <sub>2</sub>	C
Lumbar (1 + 2)	-	-	-	115.6 ± 9.0
Lumbar (3)	0.150 ± 0.007	188 ± 24	841 ± 59	-
Lumbar (4 + 5)	-	-	-	119.4 ± 5.3
Ilium	0.138 ± 0.004	187 ± 14	824 ± 34	86.4 ± 1.8
Caudal (Proximal)	-	-	-	37.4 ± 1.6
Caudal (Central)	0.559 ± 0.012	333 ± 68	238 ± 28	-
Caudal (Distal)	-	-	-	58.2 ± 13.2

TABLE 1: Values describing the plutonium-239 distribution in various bones of the female CBA mouse at 24 hours post-injection.

- f : Fraction of total track ends associated with periosteal edges.
- t<sub>1</sub>: Concentration of track-ends associated with periosteal edges (track-ends/cm).
- t<sub>2</sub>: Concentration of track-ends associated with endosteal edges (track-ends/cm).
- C : Concentration of plutonium-239 in the whole bone (% injected activity/g ash).

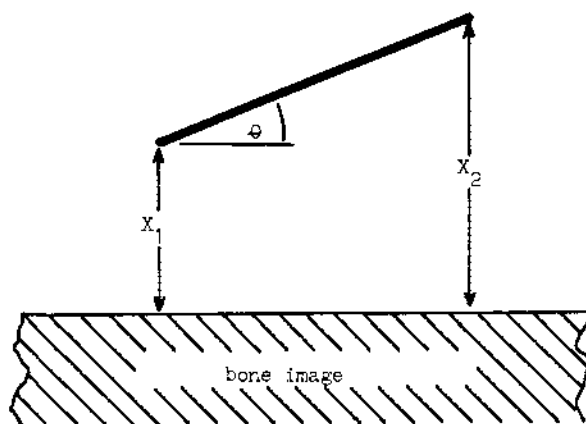

Figure 1. Quantities derived from the digitised data by the analysis programs.

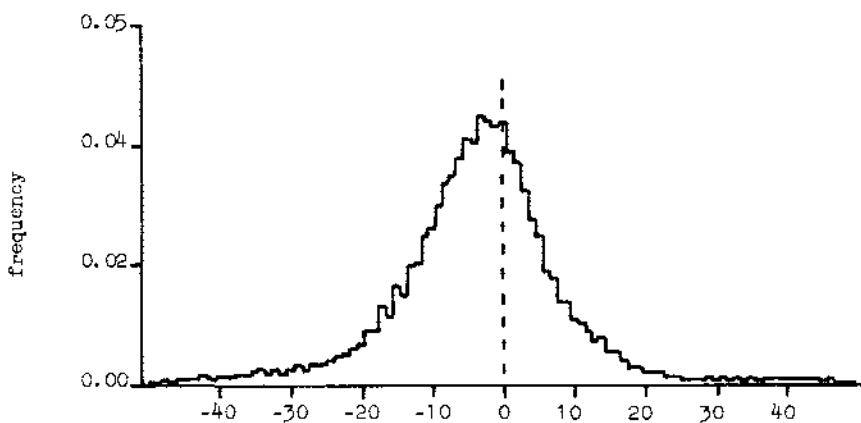

Figure 2. Weighted track-end distribution about the endosteal surfaces of the third lumbar vertebra at 24 hours post-injection. Negative distances are within the bone image.

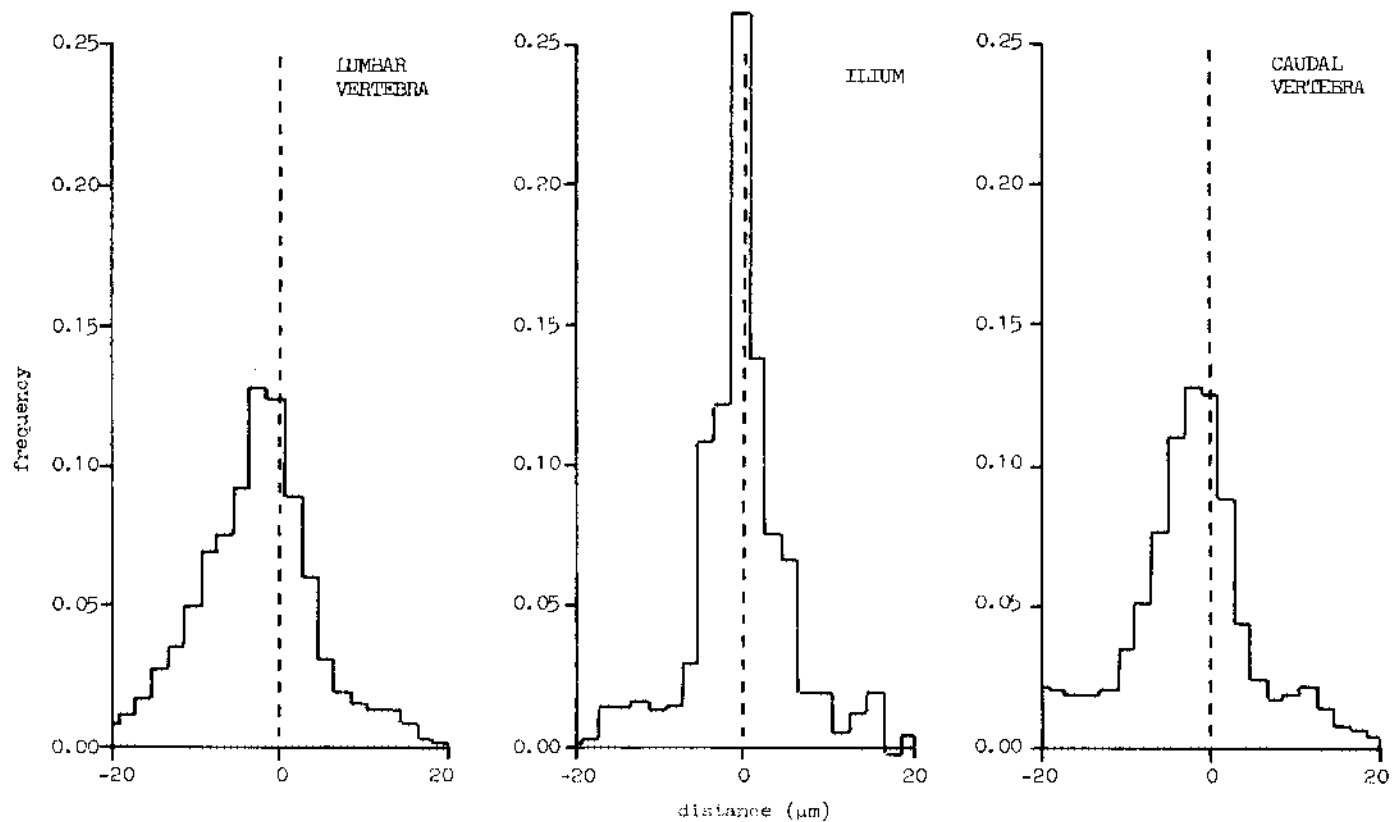

Figure 3. Plutonium-239 distributions about endosteal surfaces at 24 hours post-injection. Negative distances are within the bone image.

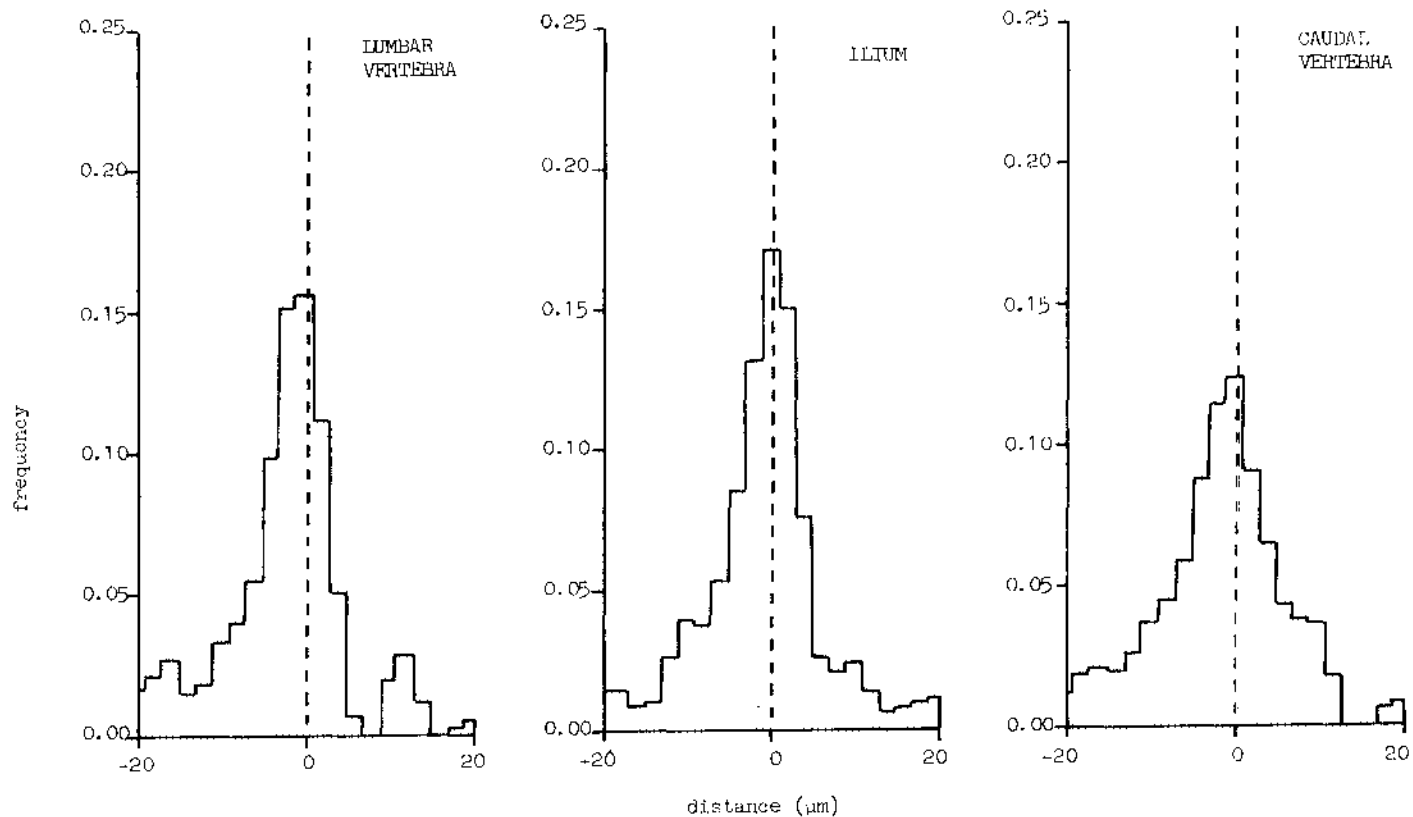

Figure 4. Plutonium-239 distributions about periosteal surfaces at 24 hours post-injection. Negative distances are within the bone image.

THE SIGNIFICANCE OF LIVER IN METABOLISM  
 OF PLUTONIUM-239  
 Christo Datchev  
 Chair of Medical Protection, Medical  
 Academy, Medical Faculty, Plevna

### 1. INTRODUCTION

The study of the metabolical properties of Plutonium-239 in the organism is of substantial interest because of its great toxicity. The researchers note the great influence of the chemical and physical condition of the radioisotope on the character of its distribution in the organism and the magnitude of the metabolical parameters. We have found however rather scarce literature on the metabolism of Plutonium chloride. Information about the role of the liver its barrier capabilities responsible to a certain extent for the back transport of the radionuclide from the blood plasma to liver is also next to none. Of some interest is to demonstrate what part of the radioisotope is stored in the organ and reaches the gut again through the gall. This is important for the exact determination of the coefficient of absorption of Plutonium-239. To demonstrate the barrier function of the liver we propose an original method by inserting the radioisotope into vein portae. We study as well the physico-chemical condition of Plutonium-239 in the organ.

### 2. MATERIAL AND METHODS

The experiment was made on 90 sexually mature albino rats with an average weight of 200-250 g. The radioisotope was administrated once for all directly into vein jugularis and vein portae as  $\text{PuCl}_3$  in volume of 0,1 ml and activity 0,6  $\mu\text{Ci}$ . The rats were killed through haemorrhage after 3 hours, during the 1st, 3rd and 6th days. The quantity of

Plutonium-239 in the organ was found by the  $\alpha$ -radiation of the radionuclide and by X- and  $\beta$ -radiation of its sister product Americium. The fractioning of the tissue proteins was carried out by combined methodologies by extraction and sedimentation. The radiometric analysis of the specimen was made with the aid of an  $\alpha$ -adapter. The contents of Plutonium-239 in the live animals was measured by the  $\alpha$ - and  $\beta$ -radiation of Americium on a special stand.

### 3. PRIVATE INVESTIGATION AND DISCUSSION

Our data concerning the contents of Plutonium-239 in the liver in the early periods after its administration into vein jugularis and vein portae are presented on Table 1.

TIME OF OBSERVATION	V. JUGULARIS	V. PORTAE
3 hours	46,8 $\pm$ 6,1	54,3 $\pm$ 7,6
first day	43,6 $\pm$ 5,3	60,1 $\pm$ 7,2
third day	37,4 $\pm$ 4,5	52,2 $\pm$ 6,2
sixth day	32,0 $\pm$ 4,2	43,5 $\pm$ 6,0

TABLE 1 Contents of Plutonium-239 in the rat liver in percentage of the storing in the organism related to the contents administered into v.jugularis and v.portae

The figures shown at Table 1 indicate substantial differences in the storage of the radionuclide in the liver after introduction in various parts of the blood vessel system. The insertion of the isotope in the portal vein leads to its greater sorting out with the excretion. This is shown on Table 2.

As it is seen from the data presented after the way of application the radioactivity of the excretion (total of 3 days) differs 2,5 times. particularly great difference in the radioactivity is observed during the 1st day. The portal introduction causes much more sorting out from the organism. It can be seen that liver presents a particular barrier for the radionuclide.



We presume that the introduction of the radionuclide into the portal vein leads to its fast storage in the liver and later through the gall ways the plutonium-239 in greater quantities enters the gut, than the bone tissue.

time of observation	v. jugularis	v. portae
first day	$1,6 \pm 0,12$	$5,8 \pm 0,6$
SECOnd day	$3,2 \pm 0,4$	$4,6 \pm 0,4$
third day	$0,8 \pm 0,06$	$1,3 \pm 0,02$
total of 3 days	$5,6 \pm 0,5$	$11,7 \pm 0,9$

TABLE 1 Radioactivity of the excretion at various ways of insertion of Pu-239 into the blood vessel system of a rat(% of the contents inserted)

The mechanism of storing the radioisotope in the organ is partially explained by its physico-chemical condition in the liver tissue. This is shown on table 3.

protein fraction	time of observation		
	1st day	2nd day	3rd day
ALBUMINS	$18,9 \pm 3,1$	$16,0 \pm 2,1$	$13,6 \pm 2,7$
EGGLOBULINS	$21,0 \pm 2,6$	$18,0 \pm 2,0$	$17,0 \pm 2,9$
PSEUDOGLOBULINS	$34,0 \pm 5,4$	$36,0 \pm 4,6$	$34,0 \pm 4,0$
SCLEROPROTEINS	$12,0 \pm 2,3$	$12,0 \pm 1,4$	$14,0 \pm 1,8$
SEDIMENT	$18,0 \pm 3,4$	$21,0 \pm 1,7$	$22,4 \pm 3,9$

Table 3 quantity of Plutonium-239 combined with the separate protein fraction of the liver(% of the quantity stored in the liver)

Plutonium-239 is bound in liver in complex compounds with the tissue proteins mainly with the globulins. Thus the mechanism of storing the radionuclide in the liver can also be explained. The first day after introducing the isotope the albumins get 18%, the globulins get 55%, ferritin, scleroproteins and the sediment -20% of the total quantity radionuclide stored in the organ. certain redistribution of the isotope on the separate fractions of the organ can be observed later, namely its reduc-

tion in the albumins and the globulins and its increase in the residual protein. The effective period of semiextraction of Plutonium-239 from the liver is 9,7 days. The periods of semiextraction of the isotope from the albumins, globulins and the sediment are as follows: 5,1; 8,1 and 20,3 days. Considering the fact that more than 50% of the plutonium-239 is combined with the globulins, whose period of semiextraction is close to that of radionuclide from the organ, we can admit that basically the dynamics of its exchange is determined by this complex compound of its. The data obtained show the mechanism of Plutonium-239 storage in the liver and the causes of its back transport (a certain part) in the gut through the gall. In this way a lesser part of the radionuclide will penetrate into the peripheral blood circulation than it has been presumed until now. The coefficient of absorption of Plutonium-239 by the digestive tract determined by us when defining the barrier functions of the liver differs by 22% from the value determined by conventional methods.

#### 4. CONCLUSIONS

1. By portal introduction of Plutonium-239 a certain part of the radionuclide enters the gut by way of the gall and avoids the peripheral blood circulation which demonstrates the filter capacity of the liver.
2. Plutonium-239 in the liver combines with the tissue proteins in the form of complex compounds mainly with the globulins.
3. The dynamics of the exchange of Plutonium-239 in the liver can be explained almost exclusively by the dynamics of exchange of its complex compounds with the globulins.

#### REFERENCES

- (1) ВЕЛНОВ, Ю.А. и др. ВМЖ: Плутоний 239, Медгиз, М, 1962
- (2) ВУЛДАКОВ, Л.А. и др., проблемы токсикологии плутония, Атомиздат М, 1969
- (3) КЕЧЕВ, Х.К., Върху метаболизма на стронций 90, церий 144 и плутоний 239
- (4) JEE, W.S., ARNOLD, I.S., Proc. Soc. Exptl. Biol. and Med., 1962 C. 1973
- (5) BLENZY B., BAUGHAN I., Brit. J. Radiol., 1971, 44

## A STUDY OF THE BEHAVIOUR OF THE PRIMARY PARTICLES OF RADON DECAY PRODUCTS

M.C. Subba Ramu  
 Air Monitoring Section  
 Bhabha Atomic Research Centre  
 Trombay, Bombay-400085

## 1. INTRODUCTION

The evaluation of risk due to breathing of air containing radon and its decay products has been always a challenging problem to a radiation protectionist. It is not known whether the inhalation risk based on the deposition of the primary particles (fraction unattached to aerosols) alone is sufficient. It has been shown that the unattached fraction varies considerably depending on the aerosol concentration (1). In this paper, the behaviour of the primary particles and their attachment to aerosols are studied and the risk due to deposition of the radon daughter aerosols in the lung is calculated.

## 2. BEHAVIOUR OF PRIMARY PARTICLES

A diffusion sampler described elsewhere (2) is used to measure the unattached fraction of the radon decay products. The studies are carried out in an aerosol free chamber, using highly filtered nitrogen as the medium of dispersion. Figure 1 gives the variation of the percentage of unattached fraction with time after filling radon in the chamber. In the figure, D is the delay given after replacing the air in the chamber by aerosol-free nitrogen. D has an effect in reducing the aerosol-forming species in nitrogen. Very small aerosols formed due to natural background ionisation are lost to the walls of the chamber due to rapid diffusion.

Depending on D and the concentration of radon introduced, aerosols are formed in the chamber, which affect the behaviour of the primary particles. The size of the aerosols formed changes with time so that the region of deposition of these particles in the lung is different. It is thus very difficult to define the primary particles and assess the risk on the basis of the unattached fraction alone.

## 3. ATTACHMENT OF PRIMARY PARTICLES TO AEROSOLS

The attachment of the primary particles to the aerosols formed is studied by measuring their concentrations. The degree of attachment ( $S_t$ ) is proportional to the concentration of aerosols ( $N_t$ ). Thus we can write

$$P = S_t/N_t,$$

where P is the attachment parameter. P is directly proportional to the diffusion coefficient of the primary particles and inversely to that of the aerosols. Table 1 gives the variation of P with time for D = 1 and 6 days.

An increase in the size of the aerosols formed by nucleation (vapour phase) and coagulation is likely to result in an increase in P. P decreases when

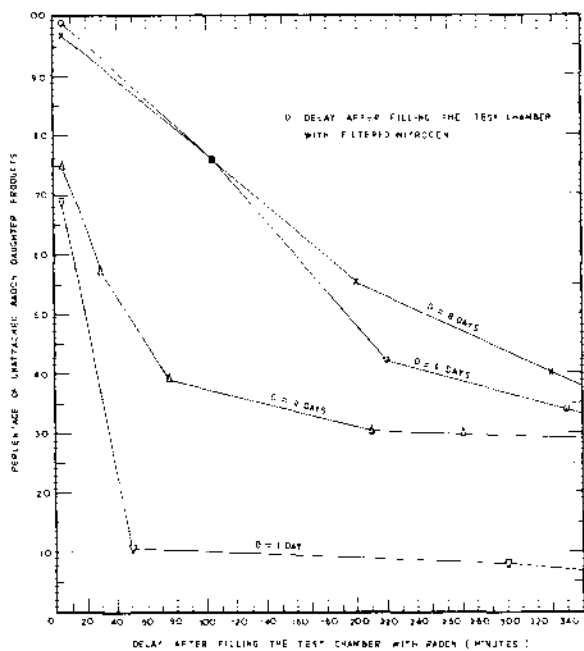

FIGURE I. VARIATION OF PERCENTAGE OF UNATTACHED RADON DAUGHTER PRODUCTS WITH TIME AFTER FILLING RADON IN THE CHAMBER

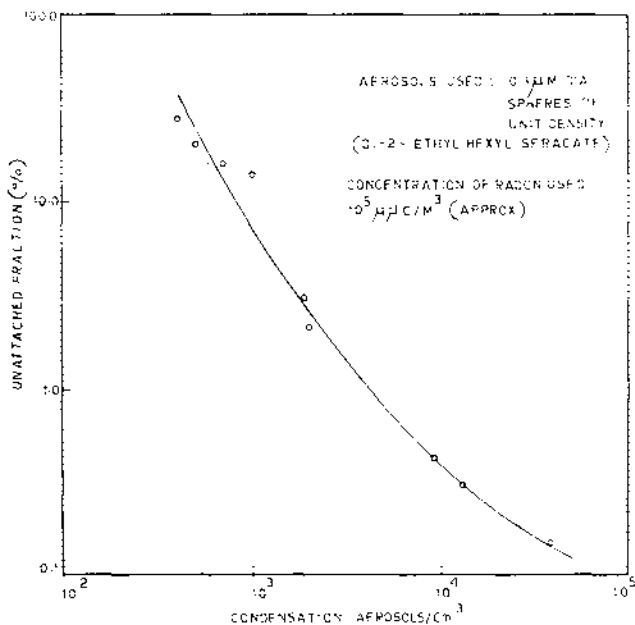

FIGURE II. A STUDY OF THE VARIATION OF THE UNCOMBINED FRACTION OF RADON DAUGHTERS WITH AEROSOL CONCENTRATION IN THE TEST CHAMBER.

the diffusion coefficient of the primary particles decreases. This indicates that they grow in size due to nucleation. P for D = 6 days is less than for D = 1 day, showing that the size of the particles formed in

D = 1 day		D = 6 days	
Time (min)	P (cm <sup>3</sup> )	Time (min)	P (cm <sup>3</sup> )
20	7.1 x 10 <sup>-4</sup>	20	1.4 x 10 <sup>-4</sup>
50	9.2 x 10 <sup>-4</sup>	50	1.7 x 10 <sup>-4</sup>
100	6.9 x 10 <sup>-4</sup>	100	2.6 x 10 <sup>-4</sup>
150	6.1 x 10 <sup>-4</sup>	150	3.6 x 10 <sup>-4</sup>
200	5.4 x 10 <sup>-4</sup>	200	4.5 x 10 <sup>-4</sup>
250	5.6 x 10 <sup>-4</sup>	250	4.9 x 10 <sup>-4</sup>
300	6.1 x 10 <sup>-4</sup>	300	5.5 x 10 <sup>-4</sup>

TABLE 1 Variation of the Attachment Parameter P with time after filling the chamber with radon.

the former case is very much less than in the other.

Experiments using different concentrations of 0.3 and 0.5  $\mu\text{m}$  dia. aerosols (unit density spheres) have shown that the unattached fraction can be reduced to as low as 0.5% (Figure II). Then, on the basis of the present criterion (ICRP), the effective dose to the lungs reduces by a factor of 16. This is obviously controversial since it is not possible to reduce the inhalation risk in an uranium mine by introducing appropriate concentrations of aerosols. Depending on the chemical nature and solubility of the aerosols, the dose to the lung would increase significantly, particularly for  $\alpha$ -emitters.

#### 4. CALCULATION OF THE INHALATION DOSE

Calculation of the dose to the lung due to the presence of  $3 \times 10^4 \mu\text{pc}/\text{m}^3$  of radon in air, in equilibrium with its decay products, has been made using the weibel's anatomical model (3). The fractions of decay products attached to aerosols of different sizes as found in a typical industrial atmosphere are calculated using appropriate attachment coefficients. The clearance of the deposited activity depending on the velocity of the mucous is taken into account. The activity deposited in the region beyond the segmental bronchi is assumed to decay completely in the lung. With such a deposition model, the radiation dose works out to be 10 times the

MPD of 15 rems per year.

#### 5. COMMENTS

The studies reported here show that the inhalation of alpha emitting isotopes is highly hazardous. The dose due to the deposition of the insoluble aerosols carrying alpha emitters in the lung is significantly high for long residence times of the deposited particles.

The risk of carcinogenesis by alpha radiation does not depend on the linear risk hypothesis and is actually under-estimated for high LET radiation. Chromosomal structural changes due to alpha interactions is highly localised so that the relative biological effectiveness increases markedly. This poses an important question whether the MPD of 15 rems per year for inhalation risk evaluation is rather high.

The analysis carried out in the present study is also important for risk estimation due to the presence of natural alpha emitters in air and cigarette smoking (4).

#### REFERENCES

- (1) GEORGE, A.C., HINCHLIFE, L. *Health Phys.* 23 (1972) 791
- (2) SUBBA RAMU, M.C. "Measurement of unattached Radon Daughter products using a Diffusion Sampler," To be Published.
- (3) WEIBEL, E.R. "Morphometry of Human Lung", (Academic Press), New York (1963).
- (4) MARTELL, E.A. *Nature*, 249 (1974) 215.

STUDY ON INTERNAL CONTAMINATION DUE TO TELLURIUM ISOTOPE  
MIXTURE

I. Fehér and A. Andrási

Central Research Institute for Physics, Budapest, Hungary

1. INTRODUCTION

$^{131}\text{I}$  is produced by use of the nuclear reactions

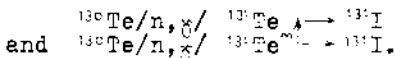

On the irradiation of  $\text{TeO}_2$ , other tellurium isotopes are also formed by  $/n, \gamma /$  reactions, such as  $^{122}\text{Te}$ ,  $^{124}\text{Te}$ ,  $^{123}\text{Te}^m$ ,  $^{125}\text{Te}^m$ ,  $^{126}\text{Te}^m$ ,  $^{127}\text{Te}$ ,  $^{129}\text{Te}^m$ ,  $^{130}\text{Te}$  with half-lives ranging from 34 to 154 days, giving a total activity comparable to that of  $^{131}\text{I}$ . The tellurium isotope mixture is removed to the waste after the separation of  $^{131}\text{I}$ , however, some radiotellurium contamination may remain in the manipulator boxes and may result in internal contamination of the personnel engaged in the repair of the equipment.

In the past few years we found internal tellurium contamination in 10 cases on persons engaged in  $^{131}\text{I}$  production. The observed tellurium retention and the maximum permissible body burden /MPBB/, and maximum permissible concentration in air /MPCa/ calculated from the observed data are discussed in the present report.

2. METHODS

The internal radiotellurium burden was determined from the  $^{123}\text{Te}^m$  159 keV gamma radiation, as measured by the HY 2.1/IAEA code number/ whole body counter in tilted chair geometry. The presence of  $^{131}\text{I}$  could not be detected in the majority of cases since the repair work was carried out after 100-300 days cooling times. The time of intake could be established to an accuracy of 1-3 days. In a few cases the Te-contamination was detected only due to the periodical whole body monitoring control, thus the retention measurement started only 30-40 days after the intake.

The fast clearance taking place in a few days following the  $\text{TeO}_2$  intake was observed on two volunteers E.I. and F.I. to whom 0.6 mg and 1.7 mg of irradiated and cooled  $\text{TeO}_2 - ^{131}\text{I}$  suspension were administered.  $^{131}\text{I}$  indicated the dissolution of the  $\text{TeO}_2$  particles. The thyroid iodine uptake of the volunteers was determined from a simultaneous  $^{131}\text{I}$  measurement.

The counting efficiency of the whole body counter was determined by use of a homogeneous BOMAB phantom.

The total dose from tellurium isotope mixture in the whole body was calculated from the effective energy, obtained from the directly measured beta and gamma doses, related to the 159 keV gamma radiation from  $^{123}\text{Te}^m$  (1).

### 3. RESULTS

3.1 Fig. 1 shows the values of  $^{123}\text{Te}^m$  retention measured on the persons contaminated during repair work as a function of the time reckoned from the assumed date of intake. During the observation time no further appreciable contamination of the persons in question was likely to occur. A weighted least square fit of the sum of two exponential functions gives for the average effective half-lives

$$T_{eff}^1 = 11 \pm 4 \text{ days and } T_{eff}^2 = 45 \pm 11 \text{ days.}$$

The ratio of the coefficients of the two exponential components is 3:1 in the case of G.T. Globally the same value was obtained for the other persons, but their ratios cannot be given individually because of the short observation time.

3.2 For the fast clearance measured on the volunteers the retention functions shown in Fig.2 were obtained. These give

$T_{eff}^0 = 0.7$  days and  $T_{eff}^1 = 10$  days average effective half-lives.

The latter value agrees well with that found for the persons contaminated during work. The coefficient ratio of the two exponential components is approximately 3:1. For personal reasons the long-lived component could not be studied on the volunteers.

The  $^{131}\text{I}$  uptake by the thyroid was slower than the  $^{125}\text{I}$  uptake in the first few hours following the  $\text{TeO}_2 - ^{131}\text{I}$  intake. The two values became equal after 10-15 hours indicating the complete dissolution of  $\text{TeO}_2$  in the gastro-intestinal tract. Our earlier in vitro experiments on the  $\text{TeO}_2 - ^{131}\text{I}$  solubility and on its uptake from the gastro-intestinal tract of rats (2) showed that the rate of  $^{131}\text{I}$  release from  $\text{TeO}_2$  is proportional to the rate of  $\text{TeO}_2$  dissolution.

The smell, like that of garlic, characteristic of dimethyl telluride, was observed in the breath of both volunteers. It disappeared only when the tellurium dioxide content of the body decreased to ~0,25 mg, that is in 2 and 6 days in the two cases.

### 4. DISCUSSION

The ICRP Publication 10 recommends the tellurium fractional retention function

$$R(t) = 0.5 e^{-\frac{0.693}{0.5}t} + 0.5 e^{-\frac{0.693}{70}t} \text{ calculated from}$$

carrierfree tellurium retention observed on animals.

The  $^{123}\text{Te}^m$  retention function evaluated for the 10 contaminated persons and the fast clearance data observed on the volunteers give

$$T_b^0 = 0.7 \text{ days, } T_b^1 = 12 \pm 4 \text{ days and } T_b^2 = 73 \pm 18 \text{ days}$$

for the three biological half-lives characterizing the tellurium dioxide clearance if we accept the physical half-life of  $^{123}\text{Te}^m$  to be 117 days.



The  $\text{TeO}_2$  fractional retention function can be written approximately as

$$R(t) = 0.7 e^{-\frac{0.693}{0.7}t} + 0.23 e^{-\frac{0.693}{12}t} + 0.07 e^{-\frac{0.693}{3}t}$$

Comparing the two retention functions in the case of the 15 mg  $\text{TeO}_2$  intake described by Reiser (3), it is found that on the 279-th day after the intake when the characteristic garlic smell was observed to disappear, the ICRP retention function gives 0.4  $\mu\text{g}$ , while on the basis of our recommendation the value is 74  $\mu\text{g}$   $\text{TeO}_2$ . If the biological variability is taken into consideration, this latter value is reasonably close to the 250  $\mu\text{g}$  when the garlic smell was observed to disappear in the case of the volunteers, while the ICRP calculation shows a value less by several orders of magnitude. Our retention values are supported also by industrial toxicological observations (4) that the garlic smell is accompanied at least by a tellurium clearance rate of a few  $\mu\text{g}/\text{day}$  in the urine and by the fact that no garlic smell was observed in the breath of cases written in 3.1, when the carrier tellurium amount was estimated to  $\leq 200$   $\mu\text{g}$ .

4.2 For the calculation of the internal radiation dose due to the intake of tellurium isotope mixture, the time integrals for unit  $^{123}\text{Te}^m$  activity

$Q_0 = 1$ ,  $Q_1 = 16$  and  $Q_2 = 65$  /activity.days/ are obtained for the three exponential components, respectively, from the retention function proposed here.

By the assumption of homogeneous distribution an average dose equivalent of  $1.3 \pm 0.5$  mrem is obtained for the 10 contaminated workers from the effective energy vs. cooling time function. This dose is negligible from the point of view of radiation hazard.

4.3 The values of MPBB given in  $^{123}\text{Te}^m$  activity measured by whole body counter along with the tellurium quantities corresponding to the MPBB calculated with the usual assumption of an irradiation for 140 hours with  $10^{13}$   $\text{cm}^{-2}$   $\text{sec}^{-1}$  neutron flux are tabulated for different cooling times as follows

Cooling time /day/	MPBB	
	$^{123}\text{Te}^m$ / $\mu\text{Ci}$ /	Te /mg/
100	30	89
200	39	206
300	48	454

In our case the chemical toxicity exceeds the radiological toxicity and above  $10^3$  MPBB the garlic smell is already observed in the breath.

4.4 The  $\text{MPC}_a$  of tellurium isotope mixture in air expressed in  $^{123}\text{Te}^m$  activity and in quantity of tellurium with an exposure for 40 hours/week, accepting the values  $T_{eff} = 45$  days,  $f_1 = 1$  and  $f_2 = 0.38$  and calculated by use of the recommendation of the ICRP Publication 2 is

$$\text{MPC}_a = 1.7 \cdot 10^{-7} \text{ Ci}/\text{m}^3, \text{ or } 500 \mu\text{g of tellurium}/\text{m}^3$$

The  $\text{MPC}_g$  for inactive tellurium is  $10 \mu\text{g}/\text{m}^3$  (5), thus radiotoxicity is negligible in comparison with chemical toxicity.

5. REFERENCES

- (1) Erdélyvári, I., Fehér, I.: Proc. of the II. Symp. on Health Phys. Vol. I., Pécs, /1966/ 163.
- (2) Fehér, I. : Thesis /1976/ /in Hungarian/
- (3) Reibert, W. : Am. J. Pharm. 56. /1884/ 177.
- (4) Steinberg, H.H, et al. : J. Ind. Hyg. Toxicol. 24. /1942/ 183.
- (5) Patty, F.A. : Ind. Hyg. and Toxicology Vol. II, /1966/ 909.

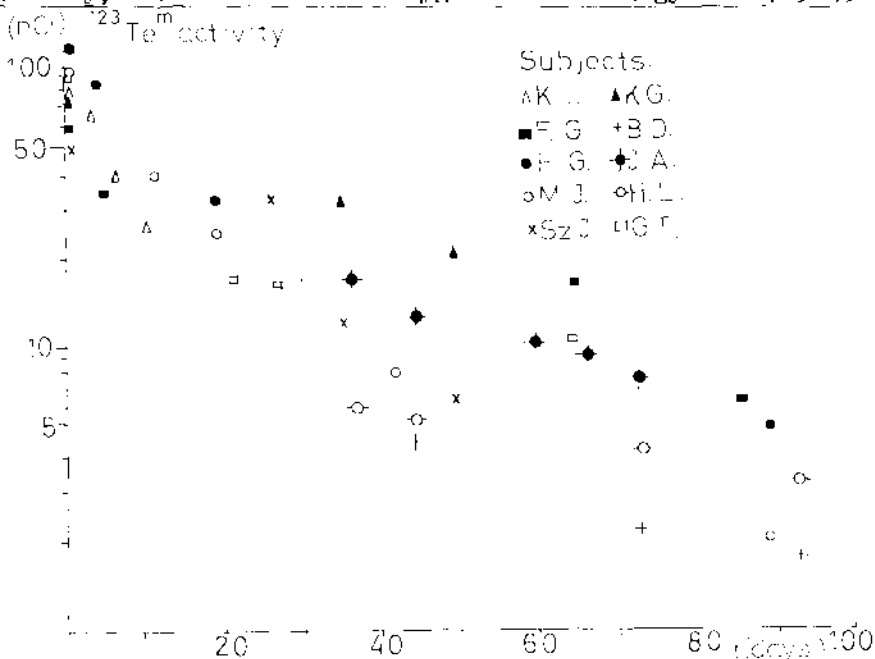

Fig.1: Whole body <sup>123</sup>Te activity measurements on contaminated persons

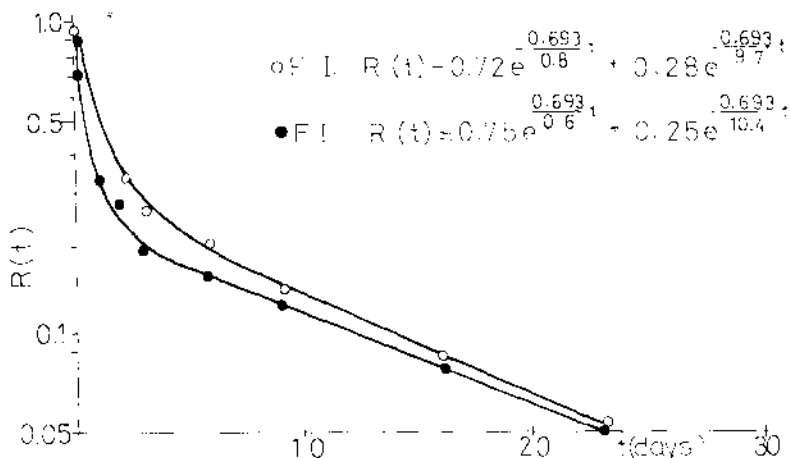

Fig.2: Retention of tellurium dioxide administered to volunteers

## THE METABOLISM AND DOSIMETRY OF CARBON-14 LABELLED COMPOUNDS

F.E.H. Crawley  
National Radiological Protection Board  
Harwell, Didcot, Oxon, England

## 1. ABSTRACT

The excretion and tissue retention of carbon-14 after the intravenous injection of carbon-14 labelled potassium cyanide and methanol in the rat, have been used to estimate the committed dose equivalent and maximum permissible annual intakes (MPAI) in man. The dose to individual tissues was more restrictive than to the whole body. The critical organ after an intake of labelled cyanide was the stomach with a MPAI of 1.5 mCi. The testes (MPAI 2.5 mCi) and the ovaries (MPAI 6.2 mCi) were the critical organs for labelled methanol.

## 2. INTRODUCTION

The number of compounds labelled at high specific activity with carbon-14 has increased greatly during the last decade. There are limited biological data available from which to assess internal radiation dose and to identify the critical tissue after an intake of these compounds. The ICRP (1) consider two Models for deriving dose, one based on an intake of bicarbonate and the other on acetate and glycine. Both Models assume complete elimination of the carbon-14 in the breath and consider only bone or whole body as critical tissues. They are not representative of many of the carbon-14 labelled compounds now available.

This paper describes data obtained in the rat after the administration of carbon-14 labelled potassium cyanide ( $K^{14}CN$ ) and methanol ( $^{14}CH_3OH$ ). Both these compounds are used frequently at high specific activity in the synthesis of labelled organic compounds. Data on the excretion and tissue retention of the carbon-14 have been used to estimate the committed dose equivalent and, hence the MPAI of these two compounds in man on the assumption that the data obtained in the rat are the same for man.

## 3. MATERIALS AND METHODS

Both labelled compounds were supplied by The Radiochemical Centre, Amersham, England and were administered to an inbred strain of rats aged 7-12 weeks. The compounds were administered to groups of rats by intravenous (i.v.) injection, pulmonary and gastric intubation and application to the intact skin (2). However, as the distribution of the carbon-14 in tissues up to one week was similar for all routes of administration data at longer time intervals were obtained after i.v. injection only. The activity administered was 1-5  $\mu Ci kg^{-1}$  body weight of cyanide and 100  $\mu g kg^{-1}$  of methanol. These amounts of material ensured that no toxic effects would be experienced by the animals.

The rats were housed in glass metabolism cages for the separate collection of urine, breath and faeces. Cumulative 24-hour samples of excreta were collected and the carbon-14 determined by liquid scintillation counting (2). All tissue samples were combusted to carbon dioxide which was trapped and the activity determined as above (2). The channels ratio method of quench correction was adopted and samples counted to within an accuracy of  $\pm 2\%$ .

Tissue	% Injected Activity in Rats		Dose (rem mCi <sup>-1</sup> ) to Man	
	K <sup>14</sup> CN	<sup>14</sup> CH <sub>3</sub> OH	K <sup>14</sup> CN	<sup>14</sup> CH <sub>3</sub> OH
Testes	0.4	0.15	2.4	2.0
Ovaries	0.08	0.015	1.1	0.8
Bone	7.5	1.9	0.0	0.5
Lung	1.0	0.33	0.09	0.07
Kidneys	1.05	0.6	0.6	0.25
Adrenals	0.03	0.01	0.5	0.5
Spleen	0.34	0.13	0.35	0.2
Heart	0.26	0.20	0.15	0.1
Brain	0.16	0.54	0.02	0.06
Liver	3.7	3.3	0.25	0.3
Fat	1.5	0.56	0.06	0.08
Muscle	12.7	16.9	0.2	0.4
GI tract	45.5	13.2	2.3	0.7
Stomach			10.7	
Small Intestine			1.2	
Large Intestine			0.7	
Whole Body			0.16	0.18

TABLE 2 Tissue Distribution of Carbon-14 at One Hour after i.v. Injection of K<sup>14</sup>CN and <sup>14</sup>CH<sub>3</sub>OH in Rats and Committed Dose Equivalent to Tissues in Man Derived from the Distribution Data in Rats

Tissue	MPAI (mCi)	
	K <sup>14</sup> CN	<sup>14</sup> CH <sub>3</sub> OH
Testes	2.1	2.5
Ovaries	4.5	6.2
Stomach	1.5	
Whole Body	31	28

TABLE 3 MPAI's of Tissues in Man Derived from the Distribution of Carbon-14 in Rats after i.v. Injection of K<sup>14</sup>CN and <sup>14</sup>CH<sub>3</sub>OH

## 4. RESULTS

### 4.1 Excretion of the Carbon-14

The values for the cumulative excretion of carbon-14 up to 60 days after i.v. injection of cyanide and methanol are given in Table 1. Although the predominant route of elimination is the urine after injection of  $K^{14}CN$  and breath in the case of  $^{14}CH_3OH$  the total amount of activity eliminated is similar. The rate of elimination of carbon-14 in the urine after administration of  $K^{14}CN$  could be described by a 3-component exponential function ( $T_b$ 's, 0.4, 2.5 and 33 days) and in the breath and faeces by single exponentials ( $T_b$ 's, 1.5 and 2.1 days respectively). After an intake of  $^{14}CH_3OH$  the rate of elimination of the carbon-14 could be represented by 3 exponentials for the urinary component ( $T_b$ 's, 0.6, 7.0 and 75 days), 3 exponentials for the breath ( $T_b$ 's, 0.5, 3.5 and 22 days) and one exponential for the faeces ( $T_b$ , 2.0 days).

	% Injected Activity	
	$K^{14}CN$	$^{14}CH_3OH$
Urine	74	21
Breath	8	73
Faeces	15	3
Total	97	97

TABLE 1 % Cumulative Excretion of Carbon-14 up to 60 Days after i.v. Injection of  $K^{14}CN$  and  $^{14}CH_3OH$  in Rats

These data were used to calculate the committed dose equivalent over 50 years to the whole body (taken as 70 kg (3)) according to the procedure formulated by the ICRP (1). The dose to the whole body after an intake of  $K^{14}CN$  was  $0.17 \text{ rem mCi}^{-1}$  and  $0.19 \text{ rem mCi}^{-1}$  after an intake of  $^{14}CH_3OH$ .

### 4.2 Tissue Distribution of the Carbon-14

There was a rapid uptake of carbon-14 in tissues with maximum levels attained with one hour of administration for most tissues (Table 2). The total activity incorporated by tissues at this time was approximately 71% of the administered activity after injection of  $K^{14}CN$  and 38% after injection of  $^{14}CH_3OH$ . This difference is almost entirely due to the high uptake of carbon-14 by the gastrointestinal (GI) tract after injection of  $K^{14}CN$ . In both studies the loss of activity from all tissues shows a similar trend, that is a rapid elimination during the first week with half-lives of 1.5-3 days accounting for 75-90% of the activity originally present. This is followed by a slower decline with half-lives ranging from 10-45 days in most tissues but up to 126 days in fat and muscle.

The committed dose equivalent to individual tissues (Table 2) was calculated from the retention data according to the ICRP (1) using the tissue masses quoted for Reference Man (3). The tissue receiving the highest dose after an intake of  $K^{14}CN$  is the stomach. This dose is an order of magnitude greater than that received by other regions of the GI tract and 4.5 times higher than the dose to the testes (next highest dose). After an intake of  $^{14}CH_3OH$  the testes receive the highest dose in males and the ovaries in females.

## 5. DISCUSSION

The pattern of elimination of the carbon-14 incorporated into  $K^{14}CN$  differs considerably from the glycine-acetate Model (1). This Model has been used for comparison with labelled cyanide and methanol as the whole body is considered to be the critical organ. If this Model is used to calculate the whole body dose after an intake of  $K^{14}CN$ , and it is accepted that 8% and not 100% of the carbon-14 is eliminated in breath, a value of 0.06 rem  $mCi^{-1}$  is obtained. This is a factor of 2.5 times lower than the dose calculated from the experimental data reported here. The corresponding dose to whole body after an intake of  $^{14}CH_3OH$ , assuming 74% of the activity in the breath, is 0.54 rem  $mCi^{-1}$ , that is 3 times higher than the dose given in Table 2. These factors are greater than the factor of 2 recommended by the ICRP (4) for the overall uncertainty in calculating the dose from external radiation.

For the purpose of the control of exposure of occupational workers it is more appropriate to derive MPAI's based on the annual dose limits recommended by the ICRP (5), that is 5 rems to whole body and gonads and 15 rems to organs such as the stomach. The MPAI's for the tissues receiving the highest doses after an intake of  $K^{14}CN$  and  $^{14}CH_3OH$  are compared with MPAI's based on whole body dose in Table 3. These values show that after an intake of  $K^{14}CN$  the stomach is the critical organ with a MPAI approximately 20 times lower than that of the whole body. After an intake of  $^{14}CH_3OH$  either the testes or ovaries is the critical organ as the MPAI's for the gonads are more restrictive than that for the whole body.

## 6. CONCLUSIONS

1. After an intake of a carbon-14 labelled compound both urine and breath should be monitored for their carbon-14 content if the predominant route of elimination is unknown.
2. If the glycine-acetate model is used to calculate the dose to whole body from the excretion data the uncertainty in the value obtained may exceed 50%.
3. The dose to individual tissues must be considered as the whole body may not be critical organ.
4. After an intake of  $K^{14}CN$ ,  $^{14}CH_3OH$  and carbon-14 labelled compounds which behave similarly in the body the MPAI is probably in the region of 1-2 mCi.

## REFERENCES

- (1) INTERNATIONAL COMMISSION ON RADIOLOGICAL PROTECTION, Publication 10, Pergamon Press, New York (1967)
- (2) CHAWLEY, F.E.H. and GODDARD, E.A., Accepted by Health Phys. (1977)
- (3) INTERNATIONAL COMMISSION ON RADIOLOGICAL PROTECTION, Publication 23, Pergamon Press, New York (1975)
- (4) INTERNATIONAL COMMISSION ON RADIOLOGICAL PROTECTION, Publication 12, Pergamon Press, New York (1969)
- (5) INTERNATIONAL COMMISSION ON RADIOLOGICAL PROTECTION, Publication 9, Pergamon Press, New York (1966)

LE DEVELOPPEMENT D'UN PROGRAMME DE PROTECTION  
DE L'ENVIRONNEMENT POUR LA POPULATION  
BASE SUR DES CONCEPTS ET DES NORMES IASPRES  
DE LA RADIOPROTECTION

Prof. P. RECHT

Directeur de la Direction "Santé et Sécurité"  
à la Commission des Communautés européennes  
Professeur à l'Université Libre de Bruxelles.

Depuis la Conférence des Nations-Unies de Stockholm en 1972 sur la protection de l'environnement, un certain nombre de principes et de méthodes ont été recommandés aux autorités nationales pour conduire des programmes de protection de l'environnement. Plusieurs de ces principes sont directement inspirés de ceux qui sont appliqués en protection radiologique; il n'est pas sans intérêt d'établir un parallèle entre ce qui a été conçu et appliqué en radioprotection pour la prévention du risque radioactif à l'égard des populations et ce qui existe actuellement ou qui est envisagé vis-à-vis des risques liés aux polluants non radioactifs.

Il est généralement admis que l'organisation de la protection contre les risques liés aux utilisations pacifiques de l'énergie nucléaire occupe une place privilégiée dans la politique de l'environnement, tant en ce qui concerne les fondements que les modalités pratiques. Sans vouloir entrer dans le détail de la description des recommandations et des réglementations en matière de radioprotection, je voudrais essayer dans ce rapport de présenter quelques notions dominantes d'une politique de radioprotection et d'examiner dans quelle mesure elles s'appliquent à une action de protection des populations et de l'environnement à l'égard d'autres pollutions et nuisances.

#### 1. IMPORTANCE DE LA PREVENTION

L'importance de la prévention apparaît dans les premières recommandations de la Commission Internationale de Protection radiologique et singulièrement dès 1956, comme un élément fondamental de l'organisation de la radioprotection. L'objectif de la radioprotection est de prévenir les effets aigus des irradiations, et de réduire à un niveau acceptable les effets tardifs, particulièrement ceux que l'on est convenu actuellement de qualifier d'effets stochastiques. Pour parvenir à cet objectif, l'intervention des pouvoirs publics à l'égard de toute activité impliquant un risque d'irradiation est considérée comme indispensable et doit être conçue de manière telle que les responsables de cette activité, tout en collaborant à l'œuvre commune de prévention et de protection, puissent être contrôlés par des organes ou des experts indépendants et qu'à aucun moment l'exploitant ne soit jugé et partie en ce qui concerne la maîtrise et le contrôle du risque radioactif. Cette notion se retrouve dans de nombreuses dispositions réglementaires nationales à l'égard des installations susceptibles de présenter un risque de nuisance pour la population ou le milieu; mais il faut reconnaître que le risque radioactif a été traité de manière spécifique et que dans la plupart des pays des dispositions particulières lui ont été appliquées et ont créé un niveau de sécurité que beaucoup d'activités industrielles n'ont pas encore réussi à atteindre. En effet, aucune activité impliquant les rayonnements ionisants ne peut être mise en œuvre sans que la conception et le déroulement de l'opération n'aient été étudiés au préalable et n'aient reçu l'accord d'autorités responsables aux différents niveaux où cette responsabilité doit s'exercer en fonction de l'importance du

risque et de l'étendue des irradiations qu'une telle activité peut entraîner.

Il faut reconnaître, en ce qui concerne les autres types d'activités industrielles et dans le domaine de l'environnement, que la préoccupation de la prévention commence à être prise en considération de manière systématique, mais n'a pas encore atteint le degré d'achèvement que l'on peut reconnaître à la radioprotection.

## 2. QUANTIFICATION DU RISQUE

Toute politique de l'environnement devrait être basée sur une évaluation aussi objective que possible du risque que présente pour l'homme ou son milieu le développement d'une activité réellement ou potentiellement polluante. C'est certainement dans ce domaine particulier que la protection radiologique a apporté les acquis les plus importants et les plus originaux.

Le "critère", dans la définition qui lui a été donnée aussi bien à la Conférence de Stockholm que dans le programme d'action des Communautés européennes (Journal officiel n° C.112 du 20 décembre 1973), apparaît comme le trait d'union indispensable entre la science et la normalisation. Les relations dose/effet, exprimées de manière quantitative, sont des instruments qui doivent être utilisés chaque fois que les données scientifiques le permettent, afin d'établir sans trop d'arbitraire, les normes ou les limites qui conditionnent l'exercice d'une activité susceptible d'être polluante.

En ce qui concerne les rayonnements ionisants et principalement la protection de la population, la relation dose/effet s'établit non pas entre une dose et un effet dommageable direct, mais entre une dose ou une exposition et un risque de probabilité d'apparition d'un dommage dans une population exposée à un niveau déterminé (détriment). Dans le cas présent, on considère essentiellement les effets cancérogènes et les effets héréditaires. Des hypothèses ont été formulées sur lesquelles il y a un consensus scientifique suffisamment large pour qu'elles puissent être admises; on accepte l'idée que toute irradiation si minime soit-elle peut être génératrice d'un risque et qu'il existe une proportionnalité entre la dose et le risque sans qu'il y ait de seuil. Il est important de souligner que cette hypothèse est conservatrice, qu'elle est formulée uniquement parce qu'on ne peut ni prouver ni infirmer scientifiquement l'absence de seuil, qu'elle permet de fixer la hauteur supérieure du risque et qu'elle met à la disposition des autorités disposant du pouvoir de décision, une référence qui leur permette de juger de l'acceptation éventuelle d'une activité nucléaire déterminée. L'absence de seuil n'est pas une doctrine, la linéarité n'est pas un dogme, elle est un modèle adopté délibérément dans le cadre de la radioprotection pour évaluer un risque hypothétique, potentiel, et qui peut dans certains cas être considéré comme égal à zéro.

Une politique de l'environnement peut s'inspirer du modèle de relation linéaire sans seuil pour les substances cancérogènes ou mutagènes, à condition que soient clairement indiquées les limites de l'application de l'hypothèse, mais elle ne s'applique pas à beaucoup de polluants non radioactifs pour lesquels il existe un seuil d'effet. Il importe donc à cet égard de qualifier le risque de manière précise avant d'adopter des modèles permettant de le quantifier. Une conséquence de l'adoption en radioprotection du concept de linéarité sans seuil est la possibilité d'exprimer la relation dose/effet soit en ordre de grandeur de risque, soit en valeur du détriment total pour une population déterminée. Des modèles de quantification se retrouvent dans les publications de la



CIPR et dans certains documents publiés par des autorités nationales, mais le mauvais usage qui en a été fait dans certains cas indique à quel point une telle quantification peut être dangereuse dans ses conséquences psychologiques et sociales.

Une autre conséquence de cette quantification, qui est contestable, est la tentative de comparer des risques, comparaison à laquelle on a procédé à différentes reprises pour tenter de démontrer que même exprimé selon le modèle choisi, le risque radioactif apparaît comme un des plus acceptables que peut supporter la société. Je ne crois pas personnellement qu'une telle comparaison soit utile au développement de l'énergie nucléaire, ni d'ailleurs à la réalisation de politiques de protection à l'égard des risques non radioactifs. Le niveau d'acceptabilité est un phénomène social complexe dans lequel la comparaison des détriments est un élément relatif et où notamment le poids des traditions nationales, des caractéristiques régionales est plus considérable qu'il n'apparaît à première vue. Dès lors, de telles comparaisons ne peuvent être établies qu'avec beaucoup de prudence, en essayant auparavant de définir de façon comparable la nature et l'importance du risque ou du détriment, et en évitant de se lancer, car nous ne sommes pas préparés à le faire pour le moment, dans des analyses coût/bénéfice où l'on exprimerait le dommage physique ou la souffrance humaine en termes monétaires.

### 3. SURVEILLANCE DE L'HOMME ET DU MILIEU

L'organisation de la surveillance de l'homme et du milieu exposés au risque d'irradiation ou de contamination est également un élément essentiel de la protection et de la prévention à l'égard desquelles la radioprotection a apporté des éléments opérationnels d'une incontestable utilité et qui peuvent être considérés comme exemplaires pour le traitement d'autres problèmes de pollution. Il y a d'abord la coopération indispensable du contrôle physique et de la surveillance médicale des individus exposés, l'enregistrement des doses d'exposition et le contrôle continu des conditions de travail, l'exigence d'une compétence particulière qui doit être acquise par les responsables du contrôle, et le développement continu par la recherche des moyens de dosimétrie individuelle et collective.

Les modèles de contamination du milieu que la radioprotection a mis au point sont basés sur les notions bien connues de radionucléides critiques, de voies critiques de transfert à l'homme et de groupes critiques de la population. Ce type d'approche peut être adopté à l'égard d'autres nuisances industrielles, mais elle en est encore au début de son application. Il est incontestable qu'affinés par leur application en radioprotection, ces modèles deviennent des instruments utiles dans le domaine de l'environnement en général pour tout ce qui concerne la fixation des limites d'exposition et de contamination liées au rejet dans les milieux atmosphérique, hydrobiologique ou terrestre et concernant les polluants métalliques ou organiques. Deux exemples sont particulièrement intéressants à signaler : ceux du mercure et des pesticides. Dès à présent, pour l'organisation de la surveillance autour des installations qui rejettent des composés de soufre et des poussières avec d'autres polluants atmosphériques, les modèles de diffusion utilisés en radioprotection ont été adoptés et l'organisation pratique de la surveillance est basée sur des concepts et des modalités analogues.

### 4. NECESSITE DE L'INFORMATION DU PUBLIC ET DES MILIEUX PROFESSIONNELS ET SOCIAUX CONCERNES PAR LA RADIOPROTECTION

De même qu'un travailleur destiné à un travail sous rayonnements ionisants doit être informé pleinement des risques et des dispositions

de sécurité, de même l'information de la population apparaît comme un élément important dans la mise en oeuvre d'une politique de protection. Les événements ont conduit la radioprotection à développer les types d'information et l'expérience acquise dans ce domaine peut être particulièrement utile pour la présentation des risques liés à d'autres activités industrielles polluant l'environnement ou intéressant la santé de l'homme.

## 5. RISQUES D'ACCIDENT

Ce que nous apprend la radioprotection dans ce domaine particulier de l'exploitation des installations nucléaires peut être présenté comme un modèle pour la protection de l'environnement en général. Aucune activité industrielle ne fait l'objet d'autant de recherches de prévention de l'accident que l'installation nucléaire. Il serait trop long d'en développer les points particuliers, mais ce rapport aurait été incomplet s'il n'avait pas signalé que les recommandations internationales et les dispositions nationales adoptent vis-à-vis du risque d'accident une philosophie orientée dans le sens de la prudence et basée sur la limitation du risque à une probabilité aussi basse que possible.

## 6. IMPORTANCE DE LA RECHERCHE

La recherche radiobiologique qui s'est développée spécialement depuis 25 ans apporte d'une manière continue des données qui sont susceptibles d'entraîner la révision des normes fondamentales de radioprotection. Ce support scientifique est indispensable pour mettre à jour, quand c'est nécessaire, les critères et les limites d'exposition. Si dans le domaine de l'environnement en général, l'utilité de la recherche est reconnue, elle n'a pas encore atteint, mais le problème est infiniment plus complexe, et diversifié, le degré de précision qui caractérise les recherches en radioprotection.

## 7. CONCLUSION

Sur base de ces concepts et modalités pratiques, il est possible de construire des programmes de prévention et de protection contre les risques non radioactifs de l'environnement, mais il ne faut pas se dissimuler les difficultés qui attendent ceux qui voudraient, sans adaptation, calquer une stratégie de la prévention ou de la protection basée uniquement sur les concepts de la radioprotection. Ce n'est pas seulement le grand nombre de polluants physiques, chimiques et biologiques qui sont en cause dans une politique de l'environnement, c'est aussi la variété des actions pathologiques qui doivent être prises en considération pour caractériser le risque. L'exemple du plomb est particulièrement significatif car le type de l'action pathologique envisagée se situe dans le domaine des signes sub-cliniques qui n'est pas analogue au concept du détriment tel qu'il est admis en radioprotection. Un autre exemple, qui est celui des composés de soufre et les poussières, illustre d'autres difficultés qui apparaissent et qui sont liées au choix du groupe critique, à la notion d'aggravation des symptômes morbides pré-existants et à l'estimation quantitative de la probabilité d'apparition d'effets considérés comme dommageables. Néanmoins, quelles que soient les variations et les modulations qui seront apportées à l'application des concepts de la radioprotection, la philosophie qui a été acceptée à l'égard des rayonnements ionisants peut s'appliquer en tout ou en partie à d'autres polluants de l'environnement; cette philosophie présente l'avantage d'avoir permis la réalisation d'une politique globale qui a été utilisée avec succès et qui a également fourni les bases d'une approche théorique et pratique complète pour la prévention et la maîtrise d'un risque industriel.

THE U.S. NATIONAL VOLUNTARY CONSENSUS NUCLEAR  
STANDARDS PROGRAM IN RADIATION PROTECTION (ANSI N-13)

McDonald E. Wrenn  
Chairman, ANSI N-13 Committee  
Department of Environmental Medicine  
New York University Medical Center  
New York, New York 10016, U.S.A.

## 1. INTRODUCTION

This paper describes the organization, composition, operation, and ongoing standards program conducted by or under the U.S. voluntary consensus organization (N-13) in the field of radiation protection.

## 2. SCOPE, COMPOSITION AND ORGANIZATION OF ACTIVITIES

The American National Standards Institute has under its aegis a variety of technical boards which supervise the development and adoption of technical consensus standards in the United States. Standards in the nuclear field fall under the N board and N-13 is the committee which is responsible for the development and adoption of (U.S.) American National Consensus Standards in the field of radiological protection. The scope indicated in the charter of the N-13 Committee is:

"Standards for the protection of individuals and groups from occupational or environmental exposure to radiation or radioactive materials either of general applicability or related to specific classes of facilities."

The N-13 Committee works closely with several other N committees, including N-42 (Nuclear Instruments), N-43 (Equipment for Nonmedical Radiation), N-44 (Equipment and Materials for Medical Radiation Applications), N-46 (Nuclear Reactor Fuel Cycle), and N-48 (Radioactive Waste Management). Consensus on several standards has been developed jointly with N-42, which is sponsored by IEEE, and a joint N-13/42 working group exists.

The committee has a chairman, a secretary, and 30 members. Twenty-seven members are organizations or societies and three are individual members. The organizations or societies appoint experts to serve as their representatives in the development of consensus. Types of organizations represented include government regulatory and development agencies, professional societies, insurance organizations, labor, industrial, trade, or professional organizations, and individual members appointed for their general technical competence. The function of the committee is to develop a consensus on draft standards submitted to it. To do this, individual members may circulate draft proposed standards for appropriate technical review within their organizations or to others whose views would be important to their organizations. A two-thirds vote of the committee is required for adoption of an American consensus standard. The direction of the committee is the function of the chairman. Administrative handling of standards balloting and compliance with the regulations of the American National Standards Institute are the responsibility of the secretary, who represents the secretariat (the Health Physics Society). The secretariat is the sponsoring organization of the committee and assumes responsibility for it.

Special writing groups may be established for the purposes of developing

standards. Administratively this is done in two separate ways. First, technical societies may be asked to form committees and to write drafts for submission to N-13 for adoption. The Health Physics Society Standard Committee is quite active in this regard and has nine working groups developing drafts of standards which will be sponsored for adoption. The American Nuclear Society writes standards related to its particular field of expertise not covered by the Health Physics Society Standard Group's writing committees. Finally, special working groups may be established by the Chairman of N-13 and these are appointed whenever it is necessary to obtain special expertise, or a particularly able individual or group exists, willing to develop the draft of a standard. The writing group may consist of several to a dozen people. Attempts are made to provide a rounded composition of the writing groups in terms of the organizations represented, but the major point in their formation is technical expertise.

The relationship between the writing groups and the N-13 Committee is at times a difficult one, because it is sometimes necessary for the N-13 Committee to return a draft to the writing committee without adoption if a national consensus cannot be reached. Often the draft standard can be revised to make it acceptable. There are many reasons why draft standards are rejected and these include such things as technical narrowness (i.e., insufficiently broad to elicit general acceptance), temporal prematurity (i.e., attempting to write standards in areas where a genuine consensus does not exist), technical errors, lack of clarity, etc.

For the most part, the process of review of draft standards is extensive and a standard may be returned many times to the writing committee before it is acceptable. This engenders delays so that the process, aside from being a thorough one, is a long and tedious one.

### 3. STANDARDS IN FORCE AND IN PREPARATION

This notwithstanding, Table 1 shows a list of 12 standards presently in force. These cover a wide range including administrative practices in radiation monitoring instrumentation, specification of standard source terms for nuclear power plants for environmental dose design calculations, guides for radiation protection in uranium mines, air sampling criteria, and performance specifications for instrumentation.

Standards may be written into government regulations or references, so that they may, if so adopted, hold greater legal force than the voluntary standard would assume by itself.

In addition to the standards already adopted, active work is underway on about 20 standards in five different areas (see Table 2 for a complete list). In radiation protection instrumentation and its applications, work is underway on several standards including performance specifications for thermoluminescent dosimeter monitoring of occupational workers, several in the field of environmental contamination, and several standards dealing with contamination of equipment and facilities. A series of standards dealing with environmental radiation surveillance from objectives to techniques are underway, some specific for facilities, such as nuclear power plants. Finally, a number of standards on internal dosimetry techniques are being prepared primarily with respect to occupational exposure and covering activation and fission products, tritium, uranium, and plutonium.

As the standards being worked on are adopted, they may then be available for international models. Conversely it is hoped that work in other

countries on similar standards will be brought to our attention.

#### ACKNOWLEDGMENTS

Thanks are due to the following who ably serve N-13 in various capacities: Richard J. Burk, Jr., who serves as Secretary of N-13; Robert A. Johnson, staff assistant to the Secretary and Secretariat; Edward Vallario, who is Chairman of the Health Physics Society Standards Committee, N-13 area manager for instrumentation and their applications, and chairman of the joint N13/42 working group; and Paul Vollique, who chairs the ANS standards committee for radiation protection. Also, thanks are due to Louis Costrell, Chairman of N-42.

TABLE 1

LIST OF N-13 STANDARDS CURRENTLY IN FORCE

<u>ANSI NO.</u>	<u>TITLE</u>
N13.1-1969*	Guide to Sampling Airborne Radioactive Materials in Nuclear Facilities
N13.2-1969*	Guide to Administrative Practices in Radiation Monitoring
N13.3-1969*	Dosimetry for Criticality Accidents
N13.5-1972	Performance Specification for Direct Reading and Indirect Reading Pocket Dosimeters for X and Gamma Radiation
N13.4-1971**	Specification for Portable X and Gamma Radiation Survey Instruments
N13.6-1966/72	Practice for Occupational Radiation Exposure Systems (formerly N2.2, revised 1972)
N13.7-1973	Film Badge Performance Criteria
N13.8-1973	Radiation Protection in Uranium Mines Operation (Revision of N7.1-1960)
N13.10-1974**	Specification and Performance at On Site Instrumentation for Continuous Monitoring Radioactivity in Effluents
N237 (1977)	Source Term Specifications (Light Water Reactors)
N319 (1976)	Performance Specification for Personnel Neutron Dosimeters
N545 (1975)	Performance Testing and Procedural Specifications for Thermoluminescence Dosimetry (Environmental Applications)

Standards are available from: American National Standards Institute, 1430 Broadway, New York, New York 10018 U.S.A.

\* Under Revision

\*\* Jointly with N-42, Secretariat IEEE.

TABLE 2

LIST OF N-13 STANDARDS UNDER DEVELOPMENTRadiation Protection Instrumentation and Applications

- N317 In Plant Pu Monitoring for Personnel Protection
- N320 Performance Specifications for Reactor Emergency Monitoring Instrumentation
- N323 Radiation Protection Instrumentation Test and Calibration
- N324 Thermoluminescent Dosimetry: Standards for Performance (Occupational)
- N373 Occupational Radiation Protection in Fuel (Mixed Oxide) Fabrication Plants (Revision of N7.2-1963)

Radiation Contamination

- N328 Control of Radioactive Surface Contamination on Materials, Equipment and Facilities to be Released for Uncontrolled Use
- N547 Standards for the Unrestricted Release of Radioactivity Contaminated Real Property

Administrative Practices

- N330 Occupational Internal Radiation Exposure Evaluation and Records

Environmental Radiological Surveillance

- N13.9 Environmental Surveillance Around Nuclear Facilities
- N221 Specific Environmental Monitoring Program to Assess Operational Dose from LWRs Power Reactors
- N331 Program for Environmental Monitoring of Nuclear Reactor Installations
- N332 Programs for Monitoring Reactor Fuel Reprocessing Plants
- N333 Programs for Monitoring Reactor Fuel Fabrication Plants
- N334 Programs for Monitoring Radioactive Waste Storage Facilities
- N336 Methods for Inferring Environmental Doses
- N338 Radiation Surveys of Mine and Mill Sites
- N340 Monitoring Nuclear Facilities Upon Decommissioning
- N651 Radiation Working for the Design of Nuclear Power Plants
- N683 Facilities for Emergency Contamination Control at Plant Site

Internal Dosimetry Techniques

- N341 Internal Dosimetry Techniques for Uranium
- N343 Internal Dosimetry Techniques for Fission and Activation Products
- N548 Internal Dosimetry Techniques for Plutonium
- N716 Criteria for Testing Personnel Dosimetry Performance

## RADIOLOGICAL DESIGN CRITERIA

J. M. Selby, B. V. Andersen  
L. A. Carter and D. A. Waite

Battelle, Pacific Northwest Laboratories  
Richland, Washington USA

The design of a structure, whether it is an office building or a nuclear facility, is a systematic process which starts when the structure is scoped by the operating group. This scope includes the purpose to be served by the structure, the number of people to be housed, the space to be included within a dollar limitation, and special equipment or facility requirements. The professional architect or design engineer applies building codes, standards and manuals of good practice, together with his artistic touch, to provide a design that will be functional, legally acceptable and esthetically pleasing. The codes and guides for commercial structures have been well established. These codes, standards and manuals of good practice are continually upgraded to reflect advances in materials and practices used in construction and new requirements in fire protection and safety.

The satisfactory application of the criteria by architects normally will result in a facility which is acceptable to all affected parties. However, this is not true with respect to nuclear facilities. Many nuclear facilities, when complete, are unsatisfactory from a radiation protection point of view. Adequate physical protective features should be achieved in building construction so that supplemental administrative controls may be kept simple and workable. Many nuclear facilities fall short of adequate protective features, thus, remedial and sometimes awkward administrative procedures are required to safely conduct work. The alternative is the costly retrofitting of the facility to meet the physical requirements.

A review of existing standards, handbooks, regulations and reports dealing with radiation protection requirements for a nuclear facility reveal a decided paucity in usable radiological design criteria which can be applied by personnel engaged in the design of nuclear facilities.

There are several problems associated with the approach taken in criteria which do exist. None of them cover the entire subject or facility completely from the standpoint of establishing "codes for design". The regulations concerning the construction of reactors and plutonium facilities in the area of structure and siting provide reasonable guidance, but when it comes to radiation protection capabilities and systems there is little guidance. Some of the existing criteria appear as "Standards" and to an extent do provide general guidance to be followed. These, however, are in narrow areas and do not cover all of the radiation protection requirements.

What is badly needed is a set of criteria or codes covering specific subjects rather than specific facilities. The following are suggested as specific subjects to be considered:

- a Functional Requirements of the Facility
- b Siting and Access
- c Design Exposure Limits
- d Layout (People and Materials Flow)
- e Ventilation and Effluent Control
- f Radiation Protection Facilities and Systems

Identification of functional requirements of the facility should permit the designer, based on kind, form, quantity of radioactive materials to be used and the nature of operation planned, to determine the specific requirements to be adopted from the other functional criteria provided for nuclear facilities. We have adopted three classes of working areas based on toxicity classifications used by K. V. Morgan, et al., on "Relative Hazard of the Various Isotopes" as modified by degree of dispersibility. In this scheme 1  $\mu$ Ci of high radiotoxicity and 1  $\mu$ Ci of medium radiotoxicity materials were identified as a cutoff below which no special radiation protection requirements are placed on the facility design.

Siting and access criteria, in addition to satisfying regulatory requirements, should include consideration of the effect on surrounding buildings, operations that are sensitive to radiation, and access to special facilities such as railway spurs for the movement of heavy items and waste handling facilities.

The methodology of designing adequate shielding has been well developed. However, no consistent guidance has been provided for the resulting dose rate or accumulated dose that will be permitted outside of the shield. We take a very conservative position for design purpose since a facility is usually stressed well beyond its original design. The following criteria have been adopted for the design of new facilities:

#### Radiation Zones

Dose rates in excess of 0.5 rem/hr - access controlled by shielding or locked physical barriers

Annual Exposure < 0.5 rem (based on annual occupancy)

Weekly Exposure < 10 mrem (if annual occupancy not known)

#### Controlled Zones

Same annual or weekly exposure permitted but no dose rate in excess of 2 mrem/hr

#### Uncontrolled Zones

Dose rate < 0.2 mrem/hr

The control of people and materials flow is an extremely important item. There is always conflict between safety, security, radiation protection and operating requirements. One excellent approach to people and materials flow is to have a central equipment, piping, waste handling corridor bounded by labs on both sides. The people corridors bounding the labs for easy access with offices are located between the corridors and the outside of the building. This satisfies safety requirements for two exits from a lab, permits easy access to utilities for the labs and allows radioactive materials to be transferred without affecting the clean areas of the facility.

Excellent criteria are provided for the filters used in nuclear facilities. However, little guidance is provided on the overall requirements of the ventilation and exhaust system and little or no agreement exists on the number of stages required. (Recently the design for a facility included seven stages of filtration as an example.) As a minimum, we are specifying one absolute filter for any facility designed for unsealed low or medium radiotoxicity materials and two for a facility involving the use of



unsealed high radiotoxicity material. At least one additional filter will be required if the processes planned will disperse the materials involved. We permit the recirculation of room air from Radiation Zones even in plutonium handling areas when two absolute filters are used in series with an air monitor located between the first and second filter. The system must change automatically to single pass if the air monitor indicates the presence of radioactive contamination in excess of 8 MPC hours. More attention is being given to systems carrying radioactive solutions. In one set of requirements systems containing "high-level" process solutions must be doubly contained with primary system leak detection capability and a means of checking the integrity of the secondary containment. Systems containing "intermediate and low-level" waste solutions should either be doubly contained (preferably when direct buried) with provisions for primary system leak detection and a means of checking the integrity of the secondary containment, or be capable of a routine periodic check to assure system integrity. Systems within buildings or facilities if singly contained, must be accessible for periodic visual inspection.

One of the areas in which the greatest difficulties are encountered is in the exclusion of adequate radiation protection facilities and systems. A lab-office combination is now required for each facility containing Class A ( $> 1 \mu\text{Ci}$  of dispersible high radiotoxicity and  $> 1 \text{ mCi}$  medium radiotoxicity materials) or B work stations ( $>$  minimum cutoff defined earlier) sufficient to accommodate the following:

#### Class A Work Station

- Two monitors for the first 30 radiation workers
- One additional monitor for each additional 30 radiation workers

#### Class B Work Station

- Two monitors for the first 50 radiation workers
- One additional monitor for each additional 50 radiation workers

General building systems are usually annunciated at one location. We feel it is important that building radiation protection systems such as air monitors and area monitors should be annunciated in the Health Physics lab-office.

Other criteria that should be covered in radiological design considerations include:

- Traffic Flow and Air Locks
- Decontamination and Maintenance Facilities
- Air Monitoring or Sampling System
- Individual Laboratory Monitoring Equipment and Facilities
- Dosimeter Storage Facilities
- Posting Requirements
- Personnel Decontamination Facilities
- Breathing Air Supply System
- Material Transfer Systems
- Solid Waste Disposal System

We have attempted to scope specific subjects for which radiological design criteria should be developed to assure that the design and construction of

nuclear facilities are functional rather than requiring costly retrofitting or administrative restrictions. The examples of specific criteria were not presented as those that should be adopted. Rather they were presented to show the degree to which arbitrary decisions should be made. We have found that even if functional radiological design criteria are developed, they are not a substitute health physics representation on the design team.

THE GERMAN RADIATION PROTECTION STANDARDS

Klaus Becker and Rudolf Neider

Nuclear Standards Committee (NKe) of the  
German Standards Institute (DIN),  
Unter den Eichen 87, D-1000 Berlin 45,  
Federal Republic of Germany

The German Standards Institute (DIN Deutsches Institut für Normung, Berlin) is engaged in health physics standards development in several of its committees, primarily the

- a. Nuclear Standards Committee (NKe), which deals mainly with nuclear science and technology, the fuel cycle, and radiation protection technology,
- b. Radiology Standards Committee (NAR), whose responsibilities are traditionally the principles of radiation protection and dosimetry, applied medical dosimetry, and medical health physics,
- c. German Electrotechnical Commission (DKE), which is concerned mostly with instrumentation standards, and
- d. Material Testing Committee (PNM), which is responsible for radiation protection in nonmedical radiography.

The current body of over one hundred standards and draft standards was established to supplement the Federal German radiation protection legislation, because voluntary standards can deal in more detail with the specific practical problems. The number of standards is steadily expanding due to the vigorous efforts of about thirty working groups, consisting of essentially all leading German experts of this field. Work is supported by the industry, the German Standards Institute, and the responsible Federal Ministry of Interior.

The following groups are represented in the standards-developing bodies:

1. Licensing Authorities
2. Manufacturers
3. Utilities
4. Independent Technical Experts from Research Establishments, Universities, etc.

The standards can be purchased from Beuth-Verlag GmbH, Burggrafenstr. 4-7, D-1000 Berlin 30. Some are also available in English.

Some of the more important, and more relevant DIN radiation protection standards can be classified as follows:

### I. PRINCIPLES:

- DIN 6802 Terms and Definitions in Neutron Dosimetry
- DIN 6804 Use of Radioactive Materials in Medicine
- DIN 6814 Terms and Definitions in Radiology (3 Parts)
- DIN 6844 Handling of Open Sources in Medicine
- DIN 25400 Radiation Warning Symbols
- DIN 44420 Definitions in Radiation Measurements
- DIN 54115 Use of Sealed Sources (1 Part)

### II. DOSIMETRY AND INSTRUMENTATION:

- DIN 6800 Radiological Dosimetry (6 Parts)
- DIN 6802 Neutron Dosimetry (2 Parts)
- DIN 6802 Clinical Dosimetry (3 Parts)
- DIN 6808 Photographic Film Dosimetry
- DIN 6817 Ionization Chambers for Clinical Use
- DIN 6818 Radiation Protection Dosimetry (5 Parts)
- DIN 44422 Dimensions of Detectors
- DIN 44425 Pocket Dosimeters and Chargers
- DIN 44426 Radiation Detection Units (2 Parts)
- DIN 44429 Calibration Sources for Dose-rate Meters
- DIN 44429 Voltage for Pulse-Operated Detectors
- DIN 44430 Dimensions of Scintillators
- DIN 44480 Analogic Voltages and Digital Levels for Detectors
- DIN 44802 Testing of Amplifiers and Pre-amplifiers

### III. SHIELDING:

- DIN 6813 X-Ray Shielding and Protection Equipment
- DIN 6834 Radiation Protection Booms in Medical Facilities (5 Parts)
- DIN 6841 Lead Gels
- DIN 6845 Testing of Shielding Materials
- DIN 25407 Shielding; Lead Bricks etc. (4 Parts)
- DIN 25413 Concrete Classification in Neutron Shielding
- DIN 25420 Construction of Concrete Room Cells
- DIN 25427 Holes in Shielding Walls (2 Parts)

### IV. TRANSPORT OF RADIONUCLIDES:

- DIN 6850 Classification of Containers and Storage Facilities in Medical Installations
- DIN 25426 Sealed Sources (2 Parts)
- DIN 54115 Transport of Sealed Sources used in Industrial Radiography

#### V. RADIONUCLIDE LABORATORIES:

- DIN 6504 Design and Equipment of Nuclear Medicine Facilities
- DIN 25402 Remote Handling Devices (8 Parts)
- DIN 25412 Glove Boxes (2 Parts)
- DIN 25425 Design of Radionuclide Laboratories

#### VI. MONITORING AND DECONTAMINATION:

- DIN 25444 Air Monitoring
- DIN 25445 Surface Decontamination (2 Parts)
- DIN 25446 Treatment of Contaminated Water
- DIN 25423 Air Monitoring
- DIN 44423 Sample Containers
- DIN 44801 Contamination Detectors

#### VII. RADIOGRAPHIC AND THERAPEUTIC EQUIPMENT:

- DIN 6833 Production of Medical Radiographic Units
- DIN 6832 Installation of Radiographic Units
- DIN 6845 Testing of Radiographic Units
- DIN 6846 Gamma Treatment Facilities
- DIN 6847 Medical Betatrons (3 Parts)
- DIN 54133 Technical Radiography Equipment (3 Parts)

#### VIII. MISCELLANEOUS:

- DIN 6819 Patient Exposures in Radiography
- DIN 6827 Recording of Radiotherapy Treatment (2 Parts)
- DIN 6828 Mechanics: Safety of Devices for Medical Radiation Uses (2 Parts)
- DIN 44800 Radiation Protection Box for Fire Brigades
- DIN 25443 Radiation Protection for Ionisation Smoke Detectors

Among the various projects for future standards activities are:

1. TLE Environmental and Personnel Monitoring
2. Quality Testing and Calibration of Radiation Detectors
3. Leakage Testing of Packages
4. Disposal of Contaminated Organic Materials
5. Safety and Security Requirements for Storage of Radionuclides
6. Industrial Thickness Gauges
7. Personal Radioprotective Equipment
8. Personnel Neutron Monitoring

Further details concerning these activities can be found in publications (e.g. K. Becker and R. Neider, Atomtechnik-Atomwirtschaft, 24, 344, 1976) or by contacting the NKE Secretariat.

EXPERIENCES WITH USING A CONCEPT OF ORGAN-DOSE  
COMBINATION AS A BASIS FOR PRACTICAL MEASURES  
IN RADIATION PROTECTION

Dr. WERNLI  
Federal Institute for Reactor Research (EIR), Würenlingen,  
Switzerland

In our institute the routine individual monitoring consists mainly of measurements of the whole body- and skin doses. In some case, measurements of finger doses and internal contamination are also carried out. For a long time, only the whole body doses were presented as the exposures of the workers and used for statistical purposes. The other values were presented additionally without any correlation among them.

For the last three years our Department of Isotope Production was in steady expansion. Accordingly, incorporations got more frequent, and hand doses got higher and higher every year. This is the reason why whole body doses alone lost their significance as a measure of radiation risks at different working places.

We tried to find a concept which may enable us to determine the total radiation risk of a working place and thus may serve as a basis for practical counter-measures. Since two years, we have used a concept which is a combination of our national law and the new tendencies of ICRP.

The concept of organ dose combination

We usually distinguish 4 kinds of exposures:

1. Whole body dose (external)
2. Skin dose
3. Hand dose
4. Incorporation

The values 1, 2 and 3 are measured by suitable dosimeters. As long as the values are below the limits, we interpret the dosimeter reading as a real organ dose.

- The "whole body dose" is measured with a normal TLD-700 chips behind a material of 300 mg/cm<sup>2</sup> tissue equivalent.
- The "skin dose" is defined as the difference between a dose measured with a thin (0,015") TLD-700 chips behind a material of about 20 mg/cm<sup>2</sup> and the total body dose described above.
- The "hand dose" is measured with a normal TLD-700 chips behind a material of about 20 mg/cm<sup>2</sup> (as the fingerdosimeter is not worn during all the time when the personal dosimeter is worn, we don't subtract the total body dose from it).

As long as an internal contamination doesn't exceed the limit given by the law we use for every person the metabolism of Reference Man, i.e. the ratio between intake and dose commitment is constant for every person. For an internal contamination we don't calculate organ doses. We try to determine the intake using the metabolism of Reference Man. Then the limit for internal contamination is the maximum permissible intake.

The highest levels of internal contamination which occur in the Department of Isotope Production result from I-125 and I-131. The uptake is measured with a thyroid monitor. For calculating the intake from a measured uptake we use the factor  $f_a$  from ICRP 2.

To judge the risk of an exposure it is important to know the value of the exposure relative to the limit given by the law. For this we introduced a new value, called "Zustandsindex BI" (exposure index) in our institute. BI is defined as the ratio between registered dose or intake and the corresponding annual limit:

$$\begin{aligned}
 BI_{\text{whole body}} &= \frac{\text{whole body dose (rem)}}{5 \text{ rem}} \\
 BI_{\text{skin}} &= \frac{\text{skin dose (rem)}}{30 \text{ rem}} \\
 BI_{\text{hand}} &= \frac{\text{hand dose (rem)}}{75 \text{ rem}} \\
 BI_{\text{incorporation}} &= \frac{\text{intake}}{\text{maximum permissible annual intake}}
 \end{aligned}$$

Although our law is based on the concept of critical organ, and thus allows different organs to approach the dose limit at the same time, we introduced a stronger limitation in our concept. We define

$$BI_{\text{total}} = \sum BI_j$$

where  $j$  denotes one of the four kinds of exposures. The law prescribes that the annual  $BI_j$  be kept below 1. We attempt to do better and try to keep  $BI_{\text{total}}$  below 1 within a year and below 0,5 within a quarter of a year. The idea is to accept the same level of risk from all types of external and internal exposures or their combinations. The total risk for a worker, who receives whole body, hand and internal exposures should be kept below the same risk level as for another who only receives whole body exposures. Of course this goal can only be achieved when ICRP has corrected the relations between whole body and organ dose limits. However, this will not influence the principles of our method.

#### Practical use of the concept (an example)

All the registered exposures of each worker are put together in one dose register.

[17]

Personendosen 1975. Abteilung 1P		Ganzkörperdosis		Hautdosis		Handdosis		Inkorporation		
Nr.	Name	$BI_{\text{total}}$	mrem	$BI_{\text{H}}$	mrem	$BI_{\text{E}}$	mrem	$BI_{\text{I}}$	Nuklid $BI_{\text{I}}$	
250		0,06	280	0,06	60	< 0,01				
752		0,12	465	0,10	--			I-125	0,10	
724		0,21	90	0,21	--					
375		0,08	295	0,05	65	< 0,01	115	< 0,21	I-125	0,01
596		0,01	90	0,01	--					
257		0,47	1495	0,30	315	< 0,01	121870	0,17		
410		0,01	90	0,01	--					
159		0,01	90	0,01	--					
065		1,27	2150	0,43	2100	0,04	561470	0,75	I-125 : 0,34 I-131 : 0,32	

Fig. 1: Part of the dose register 1975 of the Dept. of Isotope Production

For a general view we use a Histogramm of  $BI_{total}$

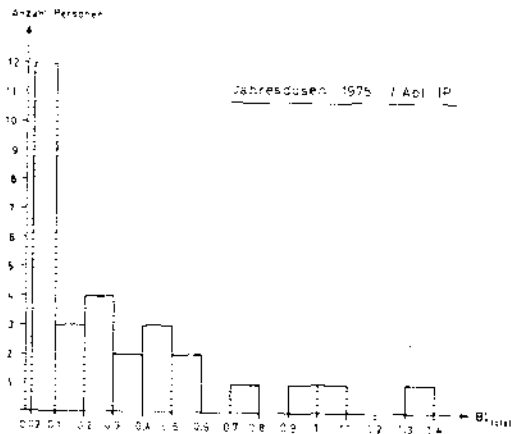

Fig. 2: Histogramm of  $BI_{Total}$  (Department of Isotope Production 1975)

The relative importance of the 4 kinds of exposures is presented in the following diagramm.

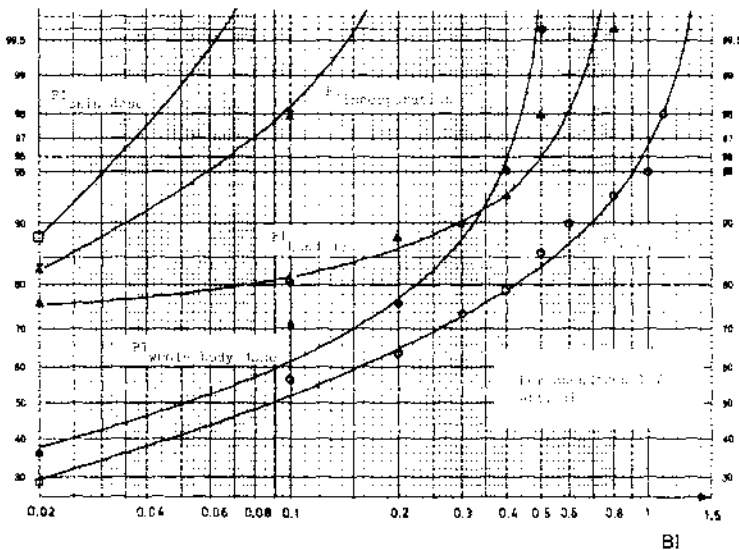

Fig. 3: Relative importance of  $BI$  (Department of Isotope Production 1975)

Since there are only 41 workers in the Department of Isotope Production the statistic is very poor and it is not surprising that  $BI$  shows no log-normal distribution. The collective dose for a single exposure is calculated by adding the proper  $BI$ . For the presentation of these values we use the



common unit "manrem", i.e. we multiply BI by 5 rem. Thus, for the Department of Isotope Production we got for 1975 :

whole body dose	23 manrem
skin dose	2 manrem
hand dose	14 manrem
Incorporation	3 manrem

#### Discussion of the presented example

Fig. 3 and the distribution of the collective dose show that the main problems of the Department of Isotope Production are due to the whole body dose and the hand dose. Fig.3 shows that there are few workers with high hand doses and that most workers got significant whole body doses. There are neither high skin doses nor important incorporations and only few workers received registered exposures of these two kinds.

We can see from Fig.3 that for two workers the  $BI_{total}$  lies above 1. Now our aim is to keep all  $BI_{total}$  below 1. From fig.3 we learn that the best way to reach that goal is to reduce the high hand doses. When we check the distribution of the different kinds of exposures of these two workers in the dose register, we find that  $BI_{hand}$  dose has really the highest value among all the  $BI_j$  (Fig.1 shows the values for one of these two workers only).

However, for a general reduction of the exposure in the Department of Isotope Production the best way is to reduce the whole body dose.

A further reduction of internal contamination or skin dose will not result in a significant change of the total exposure, even if we do it with every effort.

Our experience with the concept shows that it is a simple and useful method to determine effective counter-measures for the practical radiation protection.

#### References

ICRP Publications 2, 9, 12.

Jacobi, W., The Concept of the Effective Dose - A Proposal for the Combination of Organ Doses, Rad. and Environm. Biophys. 12, 101 - 109 (1975)

Vennart, J., The Interpretation of Exposure in Terms of Permissible Doses, Intakes and Organ Contents, International Symposium on Radiation Protection and Implementation, Aviemore, June 1974.

PLANNING OF COMBINED EXTERNAL IRRADIATION AND  
INTERNAL CONTAMINATION TO REDUCE DOSE IN NUCLEAR  
POWER PLANT OPERATIONS

H. WIJKER, N.V. KEMA, Arnhem, The Netherlands

In nuclear power plants many operations, especially during inspection, maintenance and repair, have to be carried out in cramped conditions for lack of space. Gradually the need is growing to omit, where acceptable, the hampering use of protective breathing apparatus. This may improve the quality of work - which can have a safety aspect - and it speeds up the work - which may reduce the dose from external irradiation. Though a dose by internal contamination is added, in many cases a lower total dose can be reached. This praxis however requires the introduction of a practical system of planning, controlling and accounting for internal contamination based on the evaluation of the consequences of single organ doses. For lack of time and space this paper is mainly restricted to the last aspect.

The combination of total body dose by external irradiation and organ doses by internal contamination has to be based on the sum of the respective effects. In 1969 suggestions in this direction were made by an ICRP task group [1] and more recently by Jacobi [2]. They abandoned the critical organ concept rooted in the original 15 rem/year limit for the total body (before 1956), later restricted to a maximum of 5 rem/year for gonads and blood forming organs and, consequently, for (homogeneous) total body irradiation. As far it regards somatic effects - the only effects discussed in this paper - this concept is mainly based on cancer inductions observed in atomic bomb survivors and ankylosing spondylitis patients, both groups being more vulnerable than radiological workers. This basis accounts, more or less, for synergism.

In this paper the work of ICRP and Jacobi is modified and extended

- a) by using the BEIR-1972-model [3] of latent periods (2 years for leukaemia, 15 years for other cancers) and risk periods of 25 and 30 years, respectively, with constant absolute risks per rem per year per  $10^6$  persons ( $r$ );
- b) by considering life expectancies which may reduce risk periods for doses given at later ages;
- c) by introducing a worst-cases-system for the organ dose reduction factors  $f_o$ , which are used to derive an equivalent total-body-dose-equivalent  $\Delta$  from the organ dose  $D_o$  ( $\Delta_o = f_o D_o$ , subscript o means organ). For this purpose the risk estimates derived from [1], [2], [3] and from the 1972-UNSCEAR [4] are compared.

Points a) and b) will be elucidated with an example based on risks  $r$  given by BEIR, [3] p.171. These values (see table 1) are multiplied by 5, the number of rems for the yearly maximum permissible total body dose MPD, nowadays accepted, and by the number of years at risk. These products give the lifetime risks  $R$ .

Two cases are considered :

- a) a single dose of 5 rem at a relatively low age so that the full risk period lay within the life expectancy (lifetime risk  $R_{5,1x}$ ).
- b) yearly doses of 5 rem from 18 till 65 years of age. Lifetime risk  $R_{5,y}$ . Here a number of the risk periods are limited by death. The life expectancies of Dutch men and women were used.

The sum of the risks of the various organs,  $\Sigma R$ , is the total risk. The relative contribution per organ is indicated by  $f_o = R_o / \Sigma R$ . Results are given in table 1. It can be seen that the risk  $R_{5,y}$  for women is 90 % higher than for men. The risk of breast cancer accounts for 74 %, higher life expectancy for the other 16 %. Therefore the MPD for women has to be taken about half of that of men.

The risk figures of [1], [2] and [4] have been worked out in the same way as the figures of the BEIR-report. The UNSCEAR-figures of [4], p.441, table 22, column 8, were used. For each organ the relevant groups were taken and their minimum and maximum were averaged. Jacobi and ICRP, [1] p.112, worked with relative numbers, normalized on  $r = 1$  for leukaemia, which just happens to be the absolute risk for leukaemia per rem per year per  $10^6$  persons (BEIR). This simplifies a comparison as given in table 2. They also considered curable cancers but introduced a relative severity factor  $s$ , expressing the differences in hurt of suffering and based on  $s = 1$  for cancer death. They used rough values  $s = 0.1$  and  $s = 0.3$  indicating resp. 1 order of magnitude lower and half an order lower ( $10^{1/2} \approx 0.3$ ). The starting points are given in table 2. The totals of the various systems are reasonably in accordance, the variations in the subdivisions over the organs are greater.

From these values coefficients  $f_o = R_{os}_o / \Sigma R_{os}_o$  were derived and worst factors chosen (table 3).

The maximum values of the whole system are given in the last column. It would be wise to change the value 0.44 for bone marrow into 1 because there are strong indications that the linear dose-effect relation holds for leukaemia, whereas this relation is sigmoidal for most of the other cancers. This underestimates the relative contribution of leukaemia. Starting from table 3, a grouping as given in table 4 is suggested. The  $MPD_o$  follows from  $MPD_o = 5/\bar{f}_o$  rem/year. The values suggested in table 4 show only small deviations.

The system obtained in this way is non-consistent and overestimates the influence of single organ doses. A homogeneous total body dose-equivalent of 5 rem to men considered as the sum of single organ doses would yield :  $\Delta = 5 (1 + 0.4 + 2 \times 0.2 + 5 \times 0.07 + 12 \times 0.02) = 12$  rem.

The above system is one of the items necessary to calculate the equivalent total body dose commitment per  $\mu Ci$  inhaled nuclide as well as per  $\mu Ci$  incorporated nuclide. The former is used for planning after measuring air contamination and radiation fields, the latter is used for control based on whole body counting. For the dose planning the equivalent total body dose reserve  $\Delta R$  has to be known, on a year basis as well as on a quarterly basis. To avoid unnecessary restrictions corrections have to be subtracted from the used dose commitments. This requires graphs of the change with time of the tail area in the dose rate vs time graph. Then the equivalent total body dose reserve is  $\Delta R = MPD - D_e - \Sigma_i \Delta_i$  rem/year (or quarter). Here  $D_e$  is

Organ (tissue)	r	Dose of 5 rem at relative low age			Dose of 5 rem yearly from 16 till 65 years of age						Maximum (worst) factor
		Y	R <sub>5,Y</sub>	f <sub>0</sub> = R/ΣR	Men			Women			
					Y	R <sub>5,Y</sub>	f <sub>0</sub>	Y	R <sub>5,Y</sub>	f <sub>0</sub>	
bone marrow (leukaemia)	1.0	25	25	0.19	1000	5000	0.27	1120	5600	0.29	0.29
lung	1.3	30	195	0.30	810	5300	0.27	960	6300	0.32	0.32
G.I.	1.0	30	150	0.23	810	4100	0.21	960	4800	0.25	0.25
bone	0.2	30	30	0.05	810	800	0.04	960	1000	0.05	0.05
rest	1.0	30	150	0.23	810	4100	0.21	960	4800	0.25	0.25
together	Σr=4.5		Σ R=650	1.00		19600	1.00		22500	1.16	
breast (women)	3.0	30	450	0.7				960	14500	0.74	
				1.7						1.9	
Y = years at risk											
r = risk per year per rem per 10 <sup>6</sup> persons											
R = lifetime risk per 10 <sup>6</sup> persons											
				x 1/650			x 1/19600			x 1/19600!	

Table 1. : Derivation of organ dose reduction factors  $f_0 = \Delta_0/D_0$  from BEIR-cancer death risks [3/p.17]

A Severe cancers (cancer deaths). factor s = 1					Relative hurt of suffering			
organ	UNSCEAR	BEIR	JACOBI	ICRP	organ	BEIR	JACOBI	ICRP
bone marrow	1.4	1.0	1	1	G.I.	1.0	1	0.7
lung	1.5	1.3	1	0.9	bone	0.2	0.3	0.1
rest 1	1.2	2.2	2.7	2.7	rest 2	1.0	1.4	1.9
Σr	4.1	4.5	4.7	4.6		2.2	2.7	2.7
Rest 2					Rest 3			
organ	JACOBI	ICRP	organ	ICRP	organ	UNSCEAR	JACOBI	ICRP
kidneys	0.3	0.1	pancreas	0.3	thyroid	2.5	1 (0.3)	1 (0.3)
liver	0.3	0.1	lymphnodes +	0.3	skin		0.3(0.3)	0.1(0.1)
testis	0.3	0.1	reticular tissue	0.3	eyes		1 (0.1)	
rest 3	0.5	1.6	10 organs <sup>x</sup> each 0.1	1.0	rest		0.5(0.1)	
Σr	1.4	1.9		1.6				

x) oesophagus, salivary gland, gall bladder and bile ducts, brain and nervous tissue, bladder, larynx, prostate, breast, connective tissue, eyes (cataract inst. cancer).

Table 2. : Risk on tumour induction per rem per year per 10<sup>6</sup> men (x)

the external irradiation dose and  $\Delta_i$  a corrected dose commitment from inhalation in the past year (quarter).

[1] ICRP, publ. 14, Radiosensitivity and spatial distribution of dose (1969)

[2] W. Jacobi, How shall we combine the doses to different body organs? Problems and ideas-, Int. Symp. on Rad. Prot., Aviemore June 1974 paper SR P.AV.43

[3] BEIR Adv. Comm., The effects on populations of exposure to low levels of ionizing radiation, Nov. 1972

[4] UNSCEAR, Ionizing radiation, Vol. II : Effects, 1972.

Organ	UNSCEAR	BEIR	JACOBI	ICRP	Absolute maximum
bone marrow	<u>0.44</u>	0.29	0.26	0.26	0.44+1 x)
lung	<u>0.40</u>	0.32	0.22	0.14	0.40
bone		<u>0.25</u>	0.22	0.16	0.25
kidney			<u>0.07</u>	0.02	0.07
liver			<u>0.07</u>	0.02	0.07
testis			<u>0.07</u>	0.02	0.07
pancreas				<u>0.07</u>	0.07
lymphnodes, etc				<u>0.07</u>	0.07
to various organs (note of table 2)				<u>0.02</u>	0.02
thyroid	<u>0.18</u>		0.02	0.07	0.18
skin			<u>0.02</u>	0.002	0.02
eyes			<u>0.02</u>	<u>0.02</u>	0.02
breast (w)	0.28	<u>0.74</u>		0.02	0.74
ovary				<u>0.02</u>	0.02
uterus				<u>0.02</u>	0.02

x) suggestion on base of differences in dose-effect relations (see text)

Table 3. : Maximum  $f_0$

Group	Organ(s)	$f_0$	MPD o Rem/year
1	bone	1	5
2	breast (women)	0.7	7
3	lung	0.4	12
4	bone, thyroid	0.2	30
5	kidney, liver, testis, pancreas, lymphnodes and reticular tissue	0.07	70
6	skin, eyes, ovary, uterus and other organs and tissues (note of table 2)	0.02	200

Table 4. : Suggested values of  $f_0$  and the connected MPD<sub>0</sub>

## MODELE DE COMBINAISON DES DOSES ABSORBEES DANS L'ORGANISME

J.-F. Valley et P. Lerch

Institut de radiophysique appliquée, Service de la Santé  
Publique, CH 1005 Lausanne etInstitut d'électrochimie et de radiochimie, Ecole poly-  
technique fédérale, CH 1005 Lausanne

## 1. INTRODUCTION

La procédure consistant à fixer des normes de radioprotection est malaisée, car elle est la synthèse d'un ensemble complexe de notions issues de contextes très divers : physique des radiations, biologie, radiobiologie et sociologie. De plus, les normes doivent satisfaire aux exigences suivantes :

- grandeurs physiquement définies et mesurables
- grandeurs biologiquement significatives
- grandeurs généralisables à toutes les radiations et à tous les risques qui en découlent
- champ d'application défini
- expressions et calculs simples
- corrélation simple à une notion de limite légale.

Dans la situation actuelle fixée par les recommandations de la CIPR (1), les normes sont exprimées en dose équivalente\*, produit de la dose absorbée, définie à partir de paramètres physiques, et du facteur de qualité. Par l'intermédiaire de cette dernière grandeur définie sur la base des caractéristiques microdosimétriques et radiobiologiques de la radiation, la généralisation des normes à tous les rayonnements est assurée.

Les normes fixent les doses maximales admissibles (DMA) pour chaque organe sur la base de considérations radiobiologiques et afin de tenir compte du risque global encouru par la personne irradiée. Soulignons ici que les normes concernent l'individu. En effet, l'appréciation de l'irradiation d'une population fait intervenir d'autres facteurs tels que l'incidence sociale en fonction de l'âge et du sexe de la personne irradiée.

Notons que dans ce schéma la radiobiologie intervient à deux niveaux : définition des facteurs de qualité et définition des DMA. Ceci suppose une absence de corrélation au niveau du risque entre le type de radiation et l'organe irradié.

Pour satisfaire au critère de simplicité et assurer la corrélation à la notion de limite légale, on fait appel au concept de dose à l'organe critique. Si cette méthode est satisfaisante dans le cas d'une source unique d'irradiation, il n'en est plus de même lorsque l'on est en présence de diverses sources. Une méthode de combinaison des doses est alors à définir et un critère légal clair doit remplacer les quelques remarques trop particulières consacrées à cette situation par la CIPR (1).

\* appelée ci-dessous dose

Le but de ce travail est l'étude d'un modèle de combinaison des doses obtenu par extension des concepts actuellement en vigueur.

## 2. MODELE

Lorsqu'un individu est soumis à l'action de différentes sources de radiation, les seules grandeurs strictement additives et intéressantes sont les doses équivalentes aux différents organes. La dose  $D_i$  à l'organe  $i$  est la somme sur toutes les sources  $j$  des doses partielles  $D_i^j$  :

$$D_i = \sum_j D_i^j \quad (1)$$

Afin de comparer les doses aux différents organes, on définit la dose réduite comme suit :

$$d_i = \frac{D_i}{DMA_i} \quad (2)$$

où  $DMA_i$  est la dose maximale admissible à l'organe  $i$ .

Pour une source  $j$  donnée, la situation d'irradiation d'un individu peut être représentée par la donnée des  $d_i^j$ . En utilisant une notation vectorielle et en normant la dose à l'organe critique, on obtient :

$$\vec{d}^j = (d_1^j \dots d_i^j \dots) = d_c^j (\delta_1^j, \dots, \delta_c^j = 1, \dots, \delta_i^j \dots) = d_c^j \vec{\delta}^j \quad (3)$$

où  $d_c^j$  est la dose à l'organe critique produite par la source  $j$ . Les  $\delta_i^j$  sont alors des coefficients inférieurs à 1.

On obtient pour une irradiation à plusieurs sources :

$$\vec{d} = \sum_j \vec{d}^j = \sum_j d_c^j \vec{\delta}^j \quad (4)$$

La situation d'irradiation est entièrement définie par le vecteur  $\vec{d}$ . Nous proposons comme mesure du risque global encouru la valeur absolue du vecteur  $\vec{d}$  :

$$\text{"risque"} = d = |\vec{d}| = \sqrt{\sum_{i=1}^n d_i^2} \quad (5)$$

Pour l'irradiation la plus hétérogène, l'irradiation d'un seul organe, le risque correspond à la dose réduite à l'organe. La dose maximale admissible est alors représentée par un risque  $d = 1$ .

Pour la situation homogène, irradiation de tous les organes à une même dose réduite  $d_{\text{hom}}$ , on obtient pour le risque :

$$d = d_{\text{hom}} \cdot \sqrt{n} \quad (6)$$

Le risque est ainsi pondéré lorsque plusieurs organes sont irradiés. Le facteur de pondération est fonction du nombre d'organes considérés.

La représentation géométrique du paramètre  $d$  permet de mieux apprécier sa signification. Dans l'hypervolume à  $n$  dimensions défini par les  $d_i$  l'ensemble des points satisfaisant à la condition que les doses maximales admissibles ne sont pas dépassées définit un hypercube de côté 1. L'ensemble des points  $d=1$  définit une hypersphère inscrite dans l'hypercube. L'ensemble des irradiations produit par une source est représenté par une droite. L'intersection de celle-ci avec l'hypersphère donne un "risque"  $d=1$  alors que l'intersection avec l'hypercube correspond au fait qu'une au moins des doses est égale au maximum admissible. La grandeur de la diagonale de l'hypercube donne le facteur de pondération attribué à une irradiation homogène des organes.

### 3. DISCUSSION

Le corps entier peut être considéré comme un organe et donner lieu à un vecteur de base dans la représentation vectorielle de la situation d'irradiation. Cette solution, si elle peut paraître simple, fausse cependant la notion générale d'additivité des doses équivalentes aux organes. Dans le modèle proposé, l'irradiation du corps entier à une dose  $D^{\text{ce}}$  peut être représentée par le vecteur :

$$\vec{d}^{\text{ce}} = D^{\text{ce}} \left( \dots, \frac{1}{\text{DMA}_i}, \dots \right) \quad (7)$$

où le corps entier ne figure pas dans les organes  $i$ . Pour que le risque soit égal ou supérieur à 1 lorsque la dose au corps entier est égale à la dose maximale admissible, il suffit que la DMA à un quelconque organe soit égale à la DMA pour le corps entier. Cette dernière notion est alors implicitement définie.

Le nombre d'organes  $n$  détermine la pondération apportée aux irradiations homogènes. Le lien entre ces deux grandeurs est évidemment artificiel, mais cette circonstance ne nous apparaît pas gênante, le choix du nombre d'organes à considérer étant lui-même quelque peu arbitraire.

La relation entre une source  $j$  d'irradiation et la situation d'irradiation n'est plus donnée par la notion de dose à l'organe critique, mais par la donnée du vecteur complet  $\vec{d}^j$ . Il existe une relation simple entre une grandeur mesurable comme l'activité incorporée  $A_j$  d'un radioélément  $j$  et la situation



d'irradiation  $\vec{d}$  :

$$\vec{d} = A^i \cdot \vec{\hat{A}}_i^j$$

où le vecteur  $\vec{\hat{A}}_i^j$  peut être calculé une fois pour toutes et faire l'objet d'une recommandation.

#### 4. CONCLUSIONS

Les avantages du modèle proposé peuvent se résumer comme suit :

- les paramètres biologiques apparaissent à deux niveaux uniquement : définition des QF et des DMA
- la situation d'irradiation est donnée par la dose aux divers organes
- un paramètre global, le "risque", permet de relier la situation d'irradiation aux limites maximales admissibles
- la pondération du risque lors de l'irradiation de plusieurs organes est interne au modèle et peut être fixée par le choix du nombre d'organes considérés
- la situation d'irradiation est liée aux activités incorporées et aux irradiations externes par l'intermédiaire de vecteurs qui peuvent faire l'objet d'une recommandation.

#### REFERENCE

- (1) ICRP Publication 9, Pergamon Press, Oxford (1966)

## PHOTON &amp; ELECTRON INTERACTION PROPERTIES OF ICRP REFERENCE MAN

D.R. White\*, M. Fitzgerald\* and D. Ingram†

\*Radiation Physics Department, St. Bartholomew's Hospital, London.

†Department of Medicine, St. Bartholomew's Hospital Medical College, London.

## 1. INTRODUCTION

The latest report of the ICRP Task Group of Committee 2 on Reference Man (1) contains a comprehensive tabulation of the concentrations of 51 elements in 81 organs, tissues and tissue components. The document replaces an earlier report of Committee 2, published in 1959 (2), which listed 44 elements found in 36 organs and tissues, but excluded the important C, H, N, O concentrations. The new document corrects these omissions and also includes useful data on specific gravities, organ masses and water/fat/protein contents for the systems considered.

This paper describes certain important deficiencies discovered with the new elemental compositions and outlines the mathematical procedures adopted to calculate partial and total photon and electron interaction data. The results of an analysis of the photon data (3) are discussed, together with some preliminary results of the analysis of the electron data.

## 2. TISSUE COMPOSITIONS

With the large quantities of data presented in the report it is, perhaps, not surprising that anomalies exist. By summing the masses of the elements quoted for each tissue and comparing the summation to the total mass given, it is apparent that twelve tissues have mass deficiencies in excess of 20%. Consequently, the data for gall bladder, G.I. tract (oesophagus), larynx, lymph nodes, pituitary, skeleton (bone), skeleton (trabecular), skin (epidermis), skin (dermis), thymus, trachea and urinary bladder were rejected. Generally the mass deficiencies are due to the elements C, H, N or O being omitted, but for the skeletal materials elemental calcium is not quoted.

Of the remaining 69 systems, 41 have mass errors in the range 0-2%. Seven organs and tissues, included in the calculations, have mass errors between 5% and 20%.

## 3. CALCULATION PROCEDURES.

Partial and total mass attenuation and energy absorption coefficients for 33 energies in the range 10 keV - 100 MeV were calculated (3) using the elemental cross sections of Hubbell (4) and Storm and Israel (5). Data were derived using the conventional 'mixture' rule, by summing over the 51 elements considered in the ICRP tabulation. Rad/roentgen conversion factors were calculated using the elemental composition of air given by ICRU (8). In addition, photoelectric K, L<sub>1</sub>, L<sub>2</sub>, L<sub>3</sub> absorption edges (5) for the 38 elements present with atomic numbers in excess of 30 were considered. These elements, ranging from gallium (Z : 31) to uranium (Z : 92) contribute data via absorption edges at energies above 10 keV.

Electron collision mass stopping powers were calculated for the same 33 energies from the formulae presented by Berger and Seltzer (7) and Kim

(8). Radiation mass stopping powers were derived from elemental data (7, 9) and the application of the 'mixture rule'. The c.s.d.a. ranges were calculated using a smoothing cubic-spline algorithm (10) to fit the total mass stopping power data and using the Clenshaw-Curtis (11) method for the integration of the standard range relationships (7). Mass angular scattering powers were derived from calculated elemental data (12) and the use of the 'mixture rule'.

#### 4. RESULTS

4.1 Photons. Tabulations of photon interaction data were obtained for all of the 89 accepted Reference Man tissues and organs. Detailed analyses of these tables have shown that the tissues and organs may be divided into two classes, A and B.

CLASS A contained the 'high attenuation' systems and was arbitrarily taken to include those with specific gravities  $> 1.2$  and/or mass attenuation coefficients at 10 keV  $> 0.600\text{m}^2/\text{kg}$ . This group included total body, teeth and the skeletal materials.

CLASS B contained the 'low attenuation' systems with specific gravities  $\leq 1.2$  and/or mass attenuation coefficients at 10 keV  $\leq 0.600\text{m}^2/\text{kg}$ . CLASS B tissues were divided into three sub-groups, B(I), B(II) and B(III).

B(I) was arbitrarily taken to include those 'fat-like' tissues containing  $\geq 75\%$  fat. Adipose and yellow marrow were in this category.

B(II) contained tissues with  $< 75\%$  fat and water contents. Skin, pancreas, liver and heart were classified B(II).

The 'water-like' tissues, B(III), were taken to be those with  $\geq 75\%$  water. Some 39 systems, including blood (plasma), G.I. tract, spleen, testes and thyroid were in this group.

CLASS A tissues showed a large spread in their attenuation and absorption data. For example, the low energy attenuation coefficients for teeth (enamel) was nearly seven times that for total body. Large differences ( $\sim 30\%$ ) were also noted between the interaction data for skeleton (cortical bone) and similar coefficients calculated (4) for the composition of compact bone given by ICRU (6).

Thirteen of the B(II) tissues were found to have interaction data within 9% of those for aorta, while 35 of the B(III) tissues were found to be within 6% of the data for testes (3).

The only significant absorption edge was found for thyroid, when an increase of 7% in the total interaction data was observed at 33.2 keV due to the K-edge of iodine.

4.2 Electrons. Preliminary tabulations of stopping powers, angular scattering powers and ranges have been produced for the accepted tissues and analyses of the results initiated.

For the complete set of tissues, the collision stopping powers were found to increase by some 60% from the minimum values recorded for the 'high (photon) attenuation' tissues. Radiation stopping powers and angular scattering powers showed a corresponding increase of 40% and 90-100% respectively over the minimum values which were recorded for the 'low (photon) attenuation' tissues.

The tissue groupings developed specifically for photons may be applied successfully to the electron results, but the division of CLASS B tissues into sub-groups appears to be inappropriate for stopping powers. The 62 tissues in the three CLASS B sub-groups exhibited a 20% variation from the minimum values, while 54 were found to have data within 7% of those for muscle (skeletal).

For mass angular scattering powers the variations from the minimum values recorded for CLASS A and CLASS B tissues were 50-60% and 30-40% respectively. These results appear to indicate that all, or part, of the CLASS B sub-groups should be retained for this process.

## 5. SUMMARY

The latest Reference Man document provides a useful set of elemental concentrations for the calculation of both photon and electron interaction data. All of the important interaction parameters have been calculated for 89 organs, tissues and tissue components and an attempt has been made to organise the results into rational groupings. The enhanced absorption properties of liver, spleen and thyroid reported earlier by ICRU (13) were not observed, and significant differences in the results for cortical bone compared to earlier estimates were recorded. For routine Health Physics calculations the data for one or two representative tissues within each group should give adequate results, but more stringent research applications might necessitate the use of data for specific tissues.

## REFERENCES

- (1) INTERNATIONAL COMMISSION ON RADIOLOGICAL PROTECTION, Publication 23 (1975)
- (2) INTERNATIONAL COMMISSION ON RADIOLOGICAL PROTECTION, Publication 2 (1959)
- (3) WHITE, D.R., and FITZGERALD, M. Health Phys. (in press) (1977)
- (4) HUEBELL, J.H. National Bureau of Standards, NSRDS-NBS 29 (1969)
- (5) STORM, E., and ISRAEL, H.I. Nuclear Data Tables, A7 (1970), 565-681.
- (6) NATIONAL BUREAU OF STANDARDS, Handbook 85 (1984)
- (7) BERGER, M.J., and SELTZER, S.S. National Research Council Report 1133 (1964)
- (8) KIM, Y.S. Radiat. Res., 58 (1973), 21-27.
- (9) PAGES, L., et al. Report CEA-R-3942 (1970) (Centre d'Études Nucléaires de Saclay)
- (10) REINSCH, C.H. Numerische Mathematik, 10 (1967), 177-183.
- (11) NOTTINGHAM ALGORITHM GROUP. Library Mark 4 (1974), DOI AAF
- (12) INTERNATIONAL COMMISSION ON RADIATION UNITS, Report 21 (1972)
- (13) NATIONAL BUREAU OF STANDARDS, Handbook 88 (1963)

## A COMPUTATIONAL METHOD FOR ORGAN DOSES IN RADIOLOGY

Marvin Rosenstein, Ph.D.  
Bureau of Radiological Health  
Food and Drug Administration  
Rockville, Maryland U.S.A.

## 1. INTRODUCTION

There is considerable interest in the medical, radiological health and public sectors for data that can be used easily to make estimates of organ doses that result from diagnostic radiology procedures within and among medical facilities. At these facilities the choices of technical parameters for the conduct of x-ray examinations impact significantly on patient dose.

Several efforts are underway to reduce these doses by advancing the technology of x-ray imaging, by regulating the performance of x-ray equipment, by developing routine quality control programs for x-ray facilities and by increasing the expertise and radiological health awareness of those who order and perform x-ray examinations. To assess the impact of these various endeavors it is necessary to have some mechanism for estimating organ doses as a function of the physical parameters of diagnostic exposure.

This paper describes a system for obtaining such dose estimates in which the techniques have general applicability and presents some of the initial applications.

## 2. COMPUTATIONAL TECHNIQUE

The underlying methodology is a Monte Carlo computer technique (1) which simulates and records stochastically the energy deposition of x-ray photons as they undergo physical interactions in a mathematically described heterogeneous anthropomorphic phantom. The physical processes treated in this application of the Monte Carlo technique to diagnostic photon energies are the photoelectric effect and Compton scattering, since the initial energies of the photons under study are between 20 and 150 keV. In the Monte Carlo technique the path of a photon is traced by simulating the successive interactions between the photon and the intervening matter. The energy deposited at each interaction site is calculated.

A mathematical formulation of the external human anatomy which approximates the major anatomical components of the body is used as the phantom in which the radiation transport simulation is conducted. The internal organs are defined as subregions of the phantom. Each organ defined within the phantom is considered to be homogeneous in composition and density although different compositions and densities are used for the skeletal region, lungs, thyroid and the remainder of the phantom. This approach takes into account the general size, shape, composition, location and density of actual organs. Phantoms used in conjunction with the Monte Carlo technique have been specified for a reference adult patient (2) and various pediatric patients (3).

## 3. TISSUE-AIR RATIOS - REFERENCE ADULT PATIENT

In one application the Monte Carlo technique was used to create a data base from which tissue-air ratios for a large variety of medical examinations could be derived. To achieve this, a system of 4 cm x 4 cm grid elements

was superimposed upon the x-z mid-plane of the phantom for the AP and PA views and upon the y-z mid-plane for the lateral view as shown in Figure 1 (AP only shown). Figure 1 also shows the location of various anatomical landmarks used to determine the position of x-ray fields. The anatomical landmarks are situated to be consistent with the mathematical description of the phantom.

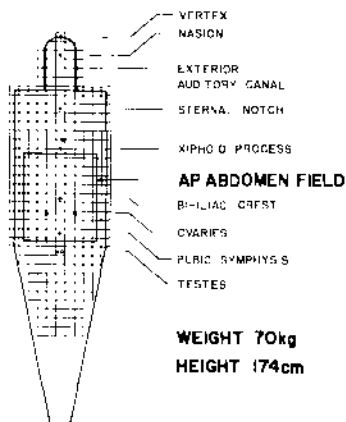

Figure 1. Reference Patient Grid and Anatomical Landmarks

Tissue-air ratios and their coefficients of variation have been tabulated for collimated, normally-incident  $4\text{ cm} \times 4\text{ cm}$  monoenergetic photon beams in the range 20 - 100 keV (1). The beams are incident upon the grid elements in each of the AP, PA and lateral views. From such a data base, the tissue-air ratios for each of the tabulated energies for an organ from a specific field size and location can be constructed.

The steps required to estimate the dose to an organ for a specified x-ray examination using the tissue-air ratios are:

- a. Identify the following x-ray examination parameters:

Projection, view  
 Location of center of x-ray field with respect to anatomical landmarks  
 Width and height of x-ray field at image receptor  
 Source-to-image receptor distance  
 Beam quality (EVL) or peak kilovoltage and total filtration  
 Entrance exposure, free-in-air

- b. Convert the width and height of the x-ray field at the image receptor to the width and height of the x-ray field at an organ reference plane.
- c. Locate the center and perimeter of the x-ray field at the organ reference plane on the  $4\text{ cm} \times 4\text{ cm}$  grid and sum the tissue-air ratios for the appropriate grid elements to obtain the tissue-air ratios for the x-ray field at each tabulated x-ray energy.
- d. Develop a tissue-air ratio table for the projection as a function of photon energy, select an appropriate x-ray spectrum based on beam quality, and weight the tissue-air ratios by the fractional

photon exposure contributions accordingly.

- e. Convert the tissue-air ratio for the projection and HVL of interest to absorbed dose in the organ using the specific entrance exposure and projection geometry.

While simple in concept, the manual calculation of any large quantity of organ doses by this procedure is a tedious and time-consuming task. A FORTRAN computer program which performs the above steps is currently available for use on both a large-scale computer and a laboratory mini-computer (4).

#### 4. HANDBOOK OF ORGAN DOSES IN DIAGNOSTIC RADIOLOGY

From the tissue-air ratios and the computer program, a compilation has been developed for selected organs (testes, ovaries, active bone marrow, thyroid and embryo/uterus) in a reference adult patient. The data are expressed as absorbed dose per unit entrance skin exposure free-in-air (mrad/R). The compilation permits absorbed doses to be estimated for a variety of projections common in diagnostic radiology. To apply the data to a practical situation, one utilizes local measurements or estimates of beam quality (HVL, mm Al) and entrance skin exposure (R, free-in-air). A Handbook is available to facilitate application of the data (5).

The projections included are:

Thoracic spine	Barium Swallow	Cystography
Skull	Scapula, Shoulder	Full Spine (Chiropractic)
Chest, Ribs	Hip	Abdominal (Retrograde pyelogram,
Cervical spine	Humerus, Femur	KUB, Barium enema, Lumbosacral
Upper G.I.	Cholecystography	spine, IVP, Renal arteriogram
Lumbar spine	Urethrogram	Pelvis, Lumbopelvic

However, the computer program discussed above would permit other projections, organs and exposure conditions to be evaluated.

An abbreviated sample of the tabulated organ doses (mrad/R) is given below for a lumbar spine projection. Deviations from the listed nominal conditions for a projection are also treated in the full compilation.

##### LUMBAR SPINE

SID = 40"; FILM SIZE = FIELD SIZE = 14" x 17"  
 ENTRANCE EXPOSURE (free-in-air) = 1 R

Beam Quality		Dose (mrad)		
HVL (mm Al) →		2.0	3.0	4.0
Testes	AP	2	6	10
	LAT	0.4	1	2
Ovaries	AP	139	238	336
	LAT	27	58	96
Active Bone Marrow	AP	21	46	81
	LAT	13	27	48
Embryo (Uterus)	AP	189	309	419
	LAT	17	39	68

#### 5. RECONSTRUCTION OF BREAST DOSES - PNEUMOTHORAX THERAPY

Another application of the methodology was to aid in obtaining estimates

of cumulative breast dose and breast cancer risk for women exposed to repeated fluoroscopic chest examinations during air collapse therapy for pulmonary tuberculosis during the period 1930-1954. The anthropomorphic reference patient was modified to include the female breasts, and x-ray spectra representing the beam qualities of interest were used as input data.

Absorbed dose (rad) in the breast per L R entrance skin exposure free-in-air was calculated for each breast for selected exposure situations. The absorbed dose in the breast is the total energy deposited in the breast volume divided by the total breast mass. These exposure situations took into account the following factors derived from patient medical records and physician interviews:

- 2 beam qualities
- 2 patient orientations (AP and PA)
- 2 breast sizes (adult and adolescent)
- 4 x-ray field sizes and locations

When these absorbed dose calculations were coupled with exposure measurements on representative fluoroscopes and information on procedures and techniques derived from medical records and interviews, patient doses and breast cancer risks as a function of cumulative breast dose rather than number of examinations were derived. For example, it was estimated that a single fluoroscopic examination would result on the average in an absorbed dose to the breast of 1.5 rad, that the average cumulative breast dose to an individual over her treatment period was approximately 150 rad, and that the best estimate of breast cancer risk for the study population was 6.2 radiation induced breast cancer cases per million woman-year rad. Each of the dose values stated above has a distribution associated with it and the breast cancer risk estimate has derived confidence limits. The study and results are described in detail elsewhere (6).

#### REFERENCES

- (1) Rosenstein, M. Organ Doses in Diagnostic Radiology. FDA 76-8030, Food and Drug Administration (May 1976).
- (2) Snyder, W.S., M.R. Ford, G.G. Warner and S.B. Watson. A Tabulation of Dose Equivalent per Microcurie - Day of Source and Target Organs of an Adult for Various Radionuclides, ORNL-5000, Oak Ridge National Laboratory (November 1974).
- (3) Hwang, J.M.L., R.L. Shoup, G.G. Warner and J.W. Poston. Mathematical Descriptions of One- and Five-Year Old Children for Use in Dosimetry Calculations. ORNL-IM 5293 (March 1976).
- (4) Andersen, L.W., M. Rosenstein and F.J. Prevo (in preparation).
- (5) Rosenstein, M. Handbook of Selected Organ Doses for Projections Common in Diagnostic Radiology. FDA 76-8031, Food and Drug Administration (May 1976).
- (6) Boice, J.D., M. Rosenstein and E.D. Trout. Estimation of Breast Cancer Risk and Breast Doses Associated with Repeated Fluoroscopic Chest Examinations of Women with Pulmonary Tuberculosis. Radiation Research (in press).



DISTRIBUTION OF DOSE WITHIN THE BODY FROM  
A PHOTON EMITTER PRESENT IN AN ORGAN\*

Walter S. Snyder,\*\* Mary R. Ford, and Gordon G. Warner\*\*\*  
Health Physics Division, Oak Ridge National Laboratory  
Oak Ridge, TN 37830

ABSTRACT

The authors have developed a dosimetric system which provides estimates of mean dose to organs from sources distributed uniformly in one or more organs (ORNL-5000, 1974; MIRD Pamphlet No. 11). Although the sources of photons are assumed to be distributed uniformly, it is not true that dose from these photons is uniformly distributed. In particular, when a source of photons is located in a particular organ, nearby tissues will be irradiated at doses which decrease markedly with distance from the source. The mean dose may give a poor approximation to the actual dose if the tissues over which dose is averaged are extensive, for example, the remainder of the body. In this paper, the authors have devised a set of "enveloping organs" for liver, lungs, etc., which give mean dose at distances from zero to one centimeters from the source organ, from one to two centimeters, etc. These can be used to yield estimates of the extent of inhomogeneity of the dose distribution from a source of photons located in the source organ. The authors are also exploring the inhomogeneity due to several such source organs.

-----

Assume a certain amount of activity of a radionuclide is distributed in a source organ and produces an average absorbed dose  $D$  in the organ. If the radionuclide emits photons the surrounding tissue also will be irradiated to some extent. Published dose tables usually give only average doses for an organ and this tends to obscure the dose from the nearby tissue since these doses are averaged over a much greater mass of tissue. For example, if a photon emitter is present in the liver, some of the tissues near the liver will get a fairly high dose but when this is averaged over the other tissues of the body the average dose is small. Of course, the same problem exists for beta rays and alpha particles, but the tissue where the peak dose outside the source organ is reached would lie very close to the source organ and be of a limited and somewhat uncertain mass. For photons, however, the extent of tissue receiving substantially the maximum level outside the source organ is much greater and those attempting to estimate risk to these tissues may wish to have this information. In this paper we only consider the question for a photon emitter.

Many calculations of dose with the source uniformly distributed in a single organ of the body have been estimated by Monte Carlo techniques which allow for estimation of dose to neighboring organs and tissues and have been reported in ORNL-5000 Parts 1 and 2 (Snyder et al. 1974, 1975). The doses received by these neighboring tissues are only reported on an average basis for an organ. These calculations utilize an anthropomorphic phantom of total mass  $\sim 70$  kg, consisting of three tissue compositions, namely, bone at a density of  $\sim 1.5$  g/cm<sup>3</sup>, lung tissue at a density of  $\sim 0.3$  g/cm<sup>3</sup>, and general soft tissues at a density of  $\sim 1$  g/cm<sup>3</sup>. Each of these has an appropriate average elemental composition (see ORNL-5000, Part 1). These

\*Research sponsored by the Energy Research and Development Administration under contract with Union Carbide Corporation.

\*\*Consultant.

\*\*\*Computer Sciences Division.

estimates have been made for 12 photon energies ranging from 0.01 MeV to 4 MeV.

In this paper we try to assess the extent of the maximum photon dose outside the source organ and the mass of tissue receiving this larger dose. The problem is complicated by the variety of shapes for the organs (ellipsoidal, truncated ellipsoids, etc.), the various energies used (twelve energies from 0.01-4 MeV), and the fact that some organs occur in pairs (kidneys, lungs, etc). No complete solution can be offered at this time but preliminary Monte Carlo calculations indicate the following general trends:

(1) For source organs occurring in pairs but separated (kidneys, ovaries, etc.) the maximum apart from the source organ seems to lie near the organ rather than at intermediate positions and this seems to hold for all energies tested;

(2) The mass of tissue irradiated outside the source organ varies with energy, as would be expected, but the ratio of the peak dose to this tissue to the average dose in the source tissue shows a remarkable stability at energies of 100 keV and higher, decreasing only slightly as energy increases. At low energies this ratio appears to increase regularly from virtually zero to the maximum at 100 keV.

(3) Detailed tables of these doses will be published when the Monte Carlo calculations are completed, but the influence of multiple source organs on the position of the maximum requires further consideration.

For example, if liver is the source tissue and if one considers the ratio of dose in a disc of thickness 1 cm based on the surface of the liver to the average dose received by the liver, this ratio increases from .07 at 10 keV to 0.74 at 100 keV and then slowly decreases to 0.63 at 4 MeV as energy increases.

#### REFERENCES

- (1) W. S. Snyder, Mary R. Ford, G. G. Warner, and Sarah B. Watson, "A Tabulation of Dose Equivalent per Microcurie-Day for Source and Target organs of an Adult for Various Radionuclides," ORNL-5000, available from National Technical Information Service, U.S. Department of Commerce, 5285 Port Royal Road, Springfield, VA 22161. Price: \$10.60.
- (2) W. S. Snyder, Mary R. Ford, G. G. Warner, and Sarah B. Watson, "A Tabulation of Dose Equivalent per Microcurie-Day for Source and Target Organs of an Adult for Various Radionuclides," ORNL-5000, Part 2, available from same source as Reference (1).
- (3) W. S. Snyder, M. R. Ford, G. G. Warner, and S. B. Watson, "I, I, Absorbed Dose per Unit Cumulated Activity for Selected Radionuclides and Organs," MIRDO Pamphlet No. 11, available from MIRDO Committee, 404 Church Avenue, Suite 15, Maryville, TN 37801. Price \$7.95.

MONTE CARLO SIMULATED DOSE TO THE HUMAN BODY  
DUE TO NEUTRONS EMITTED IN LASER FUSION

AVIVA E. GILEADI  
KMS Fusion, Inc.  
P. O. Box 1597  
Ann Arbor, Michigan 48106  
and

MARTIN O. COHEN  
Mathematical Applications Group, Inc.  
3 Westchester Plaza  
Elmsford, New York 10523

The objective of the present paper is to describe a method designed for evaluation of absorbed doses and dose equivalents due to laser-fusion neutrons, to the whole body as well as to selected organs thereof. This method is very powerful and is capable of handling neutron sources of arbitrary spectral composition and of arbitrary geometry.

Given a uniquely defined relative geometry of the human body and the neutron source under consideration, the SAM-CE system is used to solve the pertinent time, space and energy dependent transport equation. SAM-CE is a Monte Carlo computer code (1) written in FORTRAN and designed to solve the neutron and gamma ray transport equations in complex three dimensional geometries. Collision density, energy deposition and dose are treated in the SAM-CE system as flux functionals. A special feature of SAM-CE is its use of the "combinatorial geometry technique" which affords the user geometric capabilities exceeding those available with other commonly used geometric packages.

All neutron and gamma ray cross section data, as well as gamma ray production data, are derived from the ENDF libraries. Both resolved and unresolved resonance parameters from ENDF neutron data files are treated automatically and extremely precise and detailed descriptions of cross section behavior is permitted. Such treatment avoids the ambiguities usually associated with multi-group codes, which use flux-averaged cross sections based on assumed flux distributions which may or may not be appropriate.

In the present study, the geometry of the human body and a selected set of its organs was modeled according to a modified version of the heterogeneous phantom described in the MIRD No.5 pamphlet (2). The modification consisted primarily of substituting the combinatorial geometry technique instead of the analytic expressions used in the original version. The shape and size of the organ, as described in MIRD-5 (2) remained unchanged except for the thyroid and the lower portion of the large intestine where the shape was slightly changed to make description by combinatorial geometry technique possible. A total of

TABLE 1DOSE EQUIVALENTS DUE TO IRRADIATION  
BY 14.1 MeV NEUTRONS - BY ORGAN

ORGAN AND TISSUE	DOSE EQUIVALENT ( $10^{-11}$ rem per incident source neutron)
Skin of Head	.65
Skin of Torso	.65
Skin of Leg	.67
Skull	1.00
Spine	.61
Ribs	1.01
Pelvis	1.04
Armbones	1.29
Legbones	1.04
Soft Tissue in Head	.61
Brain	.65
Soft Tissue in Torso	.70
Thyroid	1.36
Thymus	.86
Lungs	.25
Heart	.86
Liver	.54
Stomach	.82
Adrenals	.46
Kidneys	.55
Spleen	.49
Pancreas	.67
Small Intestine	.75
Large Intestine ascending colon	.76
transverse	.75
lower colon	.95
Bladder	.86
Testes	.66
Soft Tissue in Leg	.69

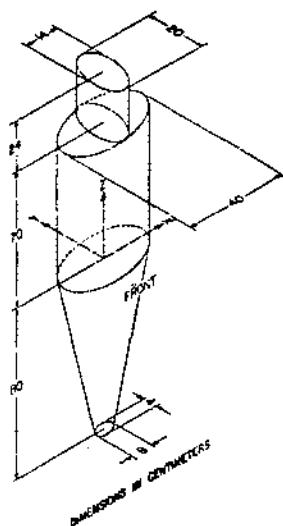

The Adult Human Phantom.

Figure 1  
(quoted from ref. 2)

65 regions were considered in this study using a total of 82 geometric bodies for the mock-up.

Number densities of the individual geometric regions, corresponding to the materials composition of the selected set of organs considered in this study were computed using data on the elemental content of organs and tissues of reference man published in the "Report of the Task Group on Reference Man", ICRP Publication 23 (3) pp. 290-304.

In a sample computation, the results of which are given in Table 1, a monoenergetic (14.1 MeV) neutron beam incident frontally at a direction parallel to the y axis (see Figure 1) was considered and dose equivalents (expressed in rems per incident source neutron) were computed, considering 3000 neutron histories, tracing approximately 87770 rays.

Gross results of these computations indicated that in the above example approximately one-third of the incident neutron energy is absorbed by the body, two-thirds of it is transmitted uncollided, and only a negligible fraction of the neutrons is slowing down past 10 keV.

Neutrons produced in laser-fusion have a definite potential for therapeutic use, primarily because of the unique space, time and energy distribution characteristics of the source.

A distinct advantage of the Monte Carlo method consists of its ability to handle almost any distribution in space, time, and energy of the source. This property makes the method adaptable for the development of dose tables for a wide variety of positioning and collimation characteristics, and space, time and energy distribution pattern of the source.

In addition to evaluating dose, dose equivalent and dose rate to the target organ from a suitably positioned and collimated

source, which may be stationary or rotational, parallel data are also obtained for non-target organs whose irradiation is unavoidably associated with that of a certain target organ. Dose tables containing such data could be put to immediate "hands-on" use in neutron therapy.

Further computational studies in progress and in planning include several of the above mentioned aspects as well as the consideration of doses due to gamma rays produced by neutron interaction with various nuclides in the human body.

#### REFERENCES

1. COHEN, M. O., et al: SAM-CE: A Three Dimensional Monte Carlo Code for the Solution of the Forward Neutron and Forward and Adjoint Gamma Ray Transport Equations. Revision D DNA 2830F Rev D - MR 7021 Rev D, Oct. 1975.
2. SNYDER, W. S. et al: Estimates of Absorbed Fractions for Monoenergetic Photon Sources Uniformly Distributed in Various Organs of a Heterogeneous Phantom. Appendix B, Mathematical Description of the Body Organs, MIRD Pamphlet No. 5, J. Nucl. Med., Suppl. 3 (1969).
3. SNYDER, W. S., et al: Report of the Task Group on Reference Man, ICRP Publication No. 23, Pergamon Press, New York 1975.

A REALISTIC CHEST PHANTOM FOR THE ASSESSMENT  
OF LOW ENERGY PHOTON EMITTERS IN HUMAN LUNGS

F.A. Fry<sup>†</sup>, B.M.R. Green<sup>†</sup>, A. Knight<sup>†</sup> and D.R. White\*

<sup>†</sup>National Radiological Protection Board, Harwell, Didcot, Oxon, England

\*Radiation Physics Department, St. Bartholomew's Hospital, London, England

ABSTRACT

The radiological control of chronically exposed plutonium workers usually involves the routine assessment of possible internal contamination. Deposits of non-transportable plutonium in lungs can be measured with suitable detectors but the severe attenuation of the low energy photons in the soft tissues and bones of the thorax presents problems of calibration. A realistic chest phantom has been designed to provide the required calibration data. The techniques have been developed on a prototype phantom and will be extended to produce a reference chest phantom which will be used in an inter-laboratory comparison of methods of in vivo assessment of low energy photon emitters.

1. INTRODUCTION

Deposits of plutonium and other transuranic nuclides in human lungs can be assessed by external measurements with suitable detectors, such as dual-phosphor scintillation detectors or proportional counters. For most of these nuclides the activity present can only be determined by measurement of the associated low energy X-ray emissions. Plutonium-239, which is of particular interest, emits uranium L X-rays of average energy 17 keV. These low energy photons are severely attenuated in the soft tissues and bones of the thorax, the half-value thicknesses being about 0.6 cm for soft tissue and about 0.04 cm for bone. Thus the number of X-rays emerging from the thorax per unit activity in the lungs is critically dependent upon the type and thickness of the overlying tissues and it is difficult to derive the activity within the chest from the observed response.

Techniques which are used to calibrate detector systems may involve the use of either a phantom (1) or a cadaver (2), or the inhalation by volunteers of a suitable short-lived nuclide which simulates the required X-ray spectrum (3). Whichever technique is used, the calibration procedure must allow for the wide range of response per unit activity observed from subjects of different body builds. Most phantoms have been designed to represent a "standard" man and calibration factors obtained from them require modification before they can be applied to subjects of a different size. Corrections to the calibration factors are most reliably based on chest wall thickness.

This paper presents a report on progress made on the design and construction of a realistic chest phantom with variable chest wall thickness.

2. SPECIFICATION OF THE CHEST PHANTOM

An ideal chest phantom should represent the upper thorax from the neck to the base of the rib cage and should contain a thoracic cage, lungs, lymph nodes, heart and liver. The thoracic cage should be representative of an average Caucasian male, with a chest circumference in the range 95 cm to 100 cm. It must be possible to vary the thickness of the chest wall from 1 cm to 4 cm. All the materials employed in the phantom should be "tissue equivalent", that is they must have the same mass density and scatter or absorb radiation in the same way as the tissues they represent. To provide the correct scattering or absorption, the partial coefficients of mass

attenuation and mass energy absorption, the electron mass stopping powers and the angular scattering powers must all be very similar to those of the tissue. In this particular application, which involves low energy photon transmission, the mass attenuation coefficients and mass density are the most important characteristics.

All the organs should be easily removable and it must be possible to simulate different distributions of nuclides within the lungs, lymph nodes and liver. In addition, if the phantom is to be used in inter-laboratory calibration exercises, it must be reasonably robust.

### 3. MATERIALS

#### 3.1 Thoracic Cages

A thoracic cage from a European man, with a chest circumference of 96 cm measured at the nipple line, has been selected and prepared with the assistance of H.M. Inspector of Anatomy and the Anatomy Department of Charing Cross Hospital Medical School. This thoracic cage will be the basis of a reference chest phantom. However, preliminary work on materials and techniques has been performed on a smaller, commercially available rib cage of Indo-Asian origin. The cartilage of the small rib cage has been replaced by 0.2 cm thick perspex, whereas the original cartilage is intact in the larger rib cage. In the region viewed by the detectors, the relative area of the anterior surface covered by the ribs and sternum is 44% for the large rib cage but only 25% for the small rib cage. Published values of the relative area covered by bone range from 40% to 50%, depending upon the size and position of the detectors. Since there is negligible transmission of 17 keV X-rays through the ribs and sternum, this difference in relative areas will lead to almost a factor of two difference in the number of photons per unit activity escaping from the anterior surface of the chest.

The small thoracic cage has been used only in a prototype phantom to develop construction techniques. The realistic phantom, intended for the inter-laboratory comparison, will contain the larger thoracic cage.

#### 3.2 Lung and Muscle Substitutes

A survey of the many materials which are claimed to be "tissue equivalent" has shown that only a few have photon attenuation coefficients within a few per cent of those of the material being simulated over the energy range from 10 keV to 100 MeV (4). There are large discrepancies at low energies, particularly for lung substitutes. At the low energies of interest, the predominant interaction is photoelectric absorption, which is strongly dependent upon the atomic numbers of the constituents. White (4) has developed new techniques for the selection of tissue substitutes and has described methods for the manufacture of many possible substitutes.

The lung substitute used for the prototype phantom was a polyurethane foam loaded with aluminium oxide. The foam was cast in slabs under pressure to produce the required density of  $0.26 \text{ g cm}^{-3}$ . A muscle substitute, of density  $1.06 \text{ g cm}^{-3}$ , has been prepared from an epoxy resin material, (LN1 of reference 4).

Mass attenuation coefficients of the substitute materials were measured at several energies within the range of interest in "narrow beam" geometry with a Si(Li) detector (Table 1). Theoretical attenuation coefficients were calculated from published elemental coefficients (5) for the substitute materials and for lung and muscle tissues of the composition given by ICRP (6). These values are included in Table 1. The measured coefficients for the muscle substitute are in good agreement with the calculated values for



muscle, within the limits of experimental uncertainty. However, an error of 5% in the attenuation coefficient of the muscle substitute at 17 keV could produce a 15% error in the calculated transmission through a chest wall consisting of 2.5 cm of muscle tissue. The chest wall actually consists of a mixture of adipose and muscle tissues and it will be necessary to produce substitutes which represent different proportions of these constituents.

Photon Energy keV	Muscle			
	Measured values*	Calculated values for substitute	Calculated values for ICRP muscle	Ratio of measured to ICRP values
8.6	7.7 ± 0.1	8.0	7.8	0.99 ± 0.01
9.6	5.5 ± 0.1	5.8	5.7	0.97 ± 0.02
9.9	5.1 ± 0.1	5.3	5.2	0.98 ± 0.02
11.0	3.7 ± 0.1	3.9	3.9	0.95 ± 0.03
17.4	1.09 ± 0.04	1.07	1.04	1.05 ± 0.04
30.8	0.36 ± 0.02	0.35	0.34	1.06 ± 0.06
58.8	0.21 ± 0.01	0.20	0.20	1.05 ± 0.04
68.2	0.19 ± 0.01	0.18	0.19	1.00 ± 0.06

Photon Energy keV	Lung			
	Measured values*	Calculated values for substitute	Calculated values for ICRP lung	Ratio of measured to ICRP values
8.6	7.1 ± 0.1	8.8	8.2	0.87 ± 0.01
17.4	1.05 ± 0.05	1.10	1.05	1.00 ± 0.05
30.8	0.33 ± 0.01	0.34	0.35	0.94 ± 0.03
58.8	0.18 ± 0.01	0.19	0.21	0.86 ± 0.05

TABLE 1 Measured and calculated attenuation coefficients ( $\text{cm}^2 \text{g}^{-1}$ )

\*The uncertainty quoted represents one standard deviation

There is reasonable agreement between the calculated values of attenuation coefficient for the lung substitute and for lung tissue but the experimental values only agreed satisfactorily at 17 keV. The composition of the lung substitute is complex and only an approximate theoretical formula was available so the discrepancy between calculated and measured coefficients could be due to a difference between the actual chemical composition and the theoretical formula available. Nonetheless, the agreement at 17 keV suggested that this material was acceptable as a lung substitute for the prototype phantom.

#### 4. CONSTRUCTION OF THE PROTOTYPE PHANTOM

The discs of lung substitute were cut to the shape of cross-sectional areas of the lung and scaled to fit the small rib cage. The sections were then

assembled to form phantom lungs. Standardised sources of the required nuclides were deposited on small slivers of the lung substitute which could then be inserted in any configuration within the phantom lungs to simulate different distributions of activity.

Moulded chest walls of uniform thickness have been produced from the muscle substitute to fit closely over the small rib cage.

## 5. DISCUSSION

The prototype phantom described in this paper will be used to obtain preliminary calibration data for the laboratory's dual-phosphor scintillation detector system. This phantom does not provide calibration data appropriate to the majority of U.K. plutonium workers because of the small size of the rib cage. The materials and techniques which have been developed during the construction of this prototype phantom will be applied to the production of a realistic chest phantom containing the larger thoracic cage. It is intended that this realistic phantom will be used in an inter-laboratory comparison of methods for in vivo assessment of the transuranic nuclides.

Future developments will include construction of the other organs within the rib cage, investigation of materials which represent soft tissues with various proportions of adipose and muscle tissues and production of phantom lungs which can be uniformly labelled with suitable nuclides.

## REFERENCES

- (1) SPEIGET, R.G., PEABODY, C.O. and RAMSDEN, D., IN Assessment of Radioactivity in Man, vol. 1, p.115. IAEA Vienna (1964)
- (2) BUKOVITZ, A.G., SAYEG, J.A., SPRITZER, A.A. and BRODSKY, A., Health Physics 17 (1969) 71
- (3) NEWTON, D., FRY, F.A., TAYLOR, B.T. and EAGLE, M.C., IN Assessment of Radioactive Contamination in Man, p.83. IAEA Vienna (1972)
- (4) WHITE, D.R., Ph.D Thesis, University of London (1974)
- (5) INTERNATIONAL COMMISSION ON RADIATION UNITS AND MEASUREMENT, Report 17 (1970)
- (6) INTERNATIONAL COMMISSION ON RADIOLOGICAL PROTECTION, Publication 23 (1974)

## PREGNANT WOMAN MODEL FOR ABSORBED FRACTION CALCULATIONS

Roger J. Cloutier, Walter S. Snyder, and Evelyn E. Watson  
Oak Ridge Associated Universities, Oak Ridge, Tennessee, U. S. A.

## 1. INTRODUCTION

The most radiation-sensitive segment of our population is the developing fetus, especially during early organogenesis when the mother is frequently unaware of the pregnancy. To evaluate the risk of exposure, health physicists must have reliable estimates of the fetal dose from all sources of radiation. One important source of fetal exposure is the exposure that may occur from radioactive material within maternal tissues. These sources are important because of the proximity of the fetus to the maternal organs.

This paper describes the models of Reference Woman that were developed to describe each month of pregnancy. The models take into account the growth of the fetus and uterine enlargement as well as the displacement of the maternal abdominal organs. These models have been used to calculate absorbed fractions for the fetus as a target and the gastrointestinal tract as a source of radiation. Absorbed fractions for twelve photon energies ranging from 10 keV to 4 MeV will be published elsewhere because of space limitations in these proceedings.

## 2. PRESENT MODELS

The Snyder and Fisher model of Reference Man (1,2) is the most widely used model for calculating absorbed fractions (3) when one organ is irradiating another. Although the model and its organs have the dimensions and weights of Reference Man, Snyder and Fisher had the foresight to include a nongravid uterus in the phantom's mathematical description. Until relatively recently, most calculations of fetal dose during early pregnancy simply used the absorbed fraction values available for Reference Man. As a first approximation, these results were useful but suffered because Reference Man is considerably larger than Reference Woman and because they apply only to the nongravid uterus.

Several years ago the authors designed a Reference Woman phantom (4) that has body dimensions and weights quite similar to the ICRP Reference Woman (5). Basically the nongravid female phantom is a reduced version of the Reference Man phantom. The pregnant phantom contains a uterus and fetus represented by a cone that enlarges and changes angle as the pregnancy progresses. Nine versions of the female phantom were designed to represent the nine months of pregnancy. Figure 1 shows the phantom for 3-, 6-, and 9-months. The nongravid phantom was used to calculate specific absorbed fractions for the fetus during early pregnancy (6). The phantoms representing the nine months of pregnancy were used to calculate absorbed fractions when a dynamic bladder was the source organ (4). The models could not be used to calculate the absorbed fractions to the fetus from other abdominal organs during late pregnancy because of the displacement of these organs as the fetus and uterus enlarge. The models described in this paper include the necessary repositioning of the maternal abdominal organs and also a slightly modified fetal-uterine model.

## 3. FEMALE PHANTOM DESIGN

The female phantom has a mass of 58 kg and a height of 164 cm. Dimensions of the female phantom are 0.94 times those of the 70-kg Reference Man phantom,  $(58/70)^{1/3} = 0.94$ . Except for a change in the angle of the uterus and the shape of the cone's vertex, the fetal-uterine model is as previously described (4). Models of the uterus beyond five months have a rounded "vertex" so that each model more nearly resembles the uterine shape that results from the usual head downward position of the fetus during this period. Using x, y, and z coordinates that have their origin at the base of the

elliptical cylinder representing the phantom's trunk, Fig. 2, we can mathematically describe the position of the various organs during pregnancy.

#### a. Three-month Pregnant Woman

In the model for the 3-month pregnant woman, the uterus is placed with the lowest generator of the cone horizontal. The cone's vertex has x, y and z coordinates of 0, -4.23, 7.52. The mass of the uterus and its contents at 3 months is 0.8 kg, which would probably depress the bladder somewhat. At this stage the uterus barely causes a bulge in the abdominal wall, Fig. 1. We neglect this small bulge, but do place the point of the uterus that is farthest in the direction of the negative y-axis at  $y = -9.2$ ; that is, it is covered only by the "skin" of the phantom. No rounding of the vertex of the cone is attempted at 3 months. When the uterus is positioned as described, the equations for the hemisphere are  $x^2 + (y+3.2)^2 + (z-12.5457)^2 \leq 36$  (1) and  $-0.84(y-4.506) + 0.55(z-7.52) \geq 9.2$ .

The equations for the conical part are  $0.84\sqrt{x^2 + (y-4.506)^2 + (z-7.52)^2} \leq -0.84(y-4.506) + 0.55(z-7.52) \leq 9.2$ . (2)

When so positioned, the uterus does not intersect most of the maternal abdominal organs, the exceptions being the bladder, small intestine, ovaries, and ascending colon. The intersections with bladder, ovaries and ascending colon are relatively minor and easily corrected by simple relocation of the organs. Considerable modification of the equations describing the small intestine were required to eliminate its intersection with the uterus. In the nonpregnant model the small intestine is described by the following equations:

$$\begin{aligned} x^2 + (y+2.572)^2 &\leq (10.62)^2, \\ -4.5684 &\leq y \leq 2.068, \\ 15.98 &\leq z \leq 25.38. \end{aligned} \quad (3a)$$

This volume also includes the transverse colon and portions of the ascending and descending colon, but these lie entirely outside the intersection with the uterus. Although in the plane  $x=0$ , Fig. 3a, the small intestine region intersects the uterus, the intersection decreases as  $|x|$  increases and finally vanishes for  $|x| > 4.9199$ . To eliminate this intersection, we devised a transformation which operates only on the intersecting regions, shaded area in Fig. 3a. The intersecting portion for each x-plane from  $x=-4.9199$  to  $x=4.9199$  is revolved  $90^\circ$  about a line parallel to the x-axis through point K. Each vertical segment is then translated upward until it no longer intersects the uterus, Fig. 3b.

In the 3-month pregnant model, the equations for the small intestine remain the same as those in Eq. 3a if  $x^2 + (y+3.2)^2 + (z-12.5457)^2 > 36$ . If  $x^2 + (y+3.2)^2 + (z-12.5457)^2 \leq 36$ , the coordinates of the final image point

$$\begin{aligned} (x', y', z') &\text{ become:} \\ x' &= x, \quad y' = 11.4116 - z, \\ z' &= 17.1141 + y + \sqrt{36 - x^2 - (y+3.2)^2}. \end{aligned} \quad (3b)$$

Because at 3 months the orientation of the fetus within the uterus is unpredictable, an average absorbed fraction for the entire volume contained with the uterine wall is calculated.

#### b. Six-month Pregnant Woman

The uterus and fetus at 6 months is intermediate between the models at 3 and 9 months. Because of the considerably larger uterus, the equations describing the abdominal organs required more modifications at 6 months than at 3 months.

#### c. Nine-month Pregnant Woman

The model for the uterus and its contents at 9 months has been slightly changed from that shown in Fig. 1. We have rounded off the vertex of the conical portion of the uterus because of the usual head downward position of

the fetus. Moreover, the axis of the uterus is placed at a smaller angle. When positioned as shown in Fig. 1, the top of the uterus is at about  $z=37$ . The diaphragm is at about  $z=40$ , leaving little space for the remaining abdominal organs. Because of the fixed location of the ribs, the trunk cannot expand outward above  $z=33$ . We therefore allowed the uterus to depress the bladder by having the lowest generator of the conical portion pass through the center of the bladder. The rounded portion of the lower end of the cone (the cervix) is kept relatively fixed.

The stomach in the 9-month phantom is rotated so that its lower portion lies along the upper surface of the uterus. The ascending colon and the transverse colon are made somewhat triangular in cross-section since they must fit into the space between the uterus and the skin. The left kidney is raised 5 cm and the right kidney 4 cm, Fig. 4. The adrenals have been redesigned so they do not extend into the lung region. The ovaries are also raised. We have relocated the small intestine into the available space between the upper part of the uterus and the spine.

#### 4. RESULTS

The absorbed fractions at 3 months are generally within a factor of two of the absorbed fractions obtained earlier by reciprocity (6). At 6 months the absorbed fractions are intermediate between those at 3 months and at 9 months of pregnancy. At 9 months, the absorbed fractions from a source organ to the different portions of the uterus and its contents depend on the source organ. For example, when the source organ is the contents of the stomach, small intestine, or the upper large intestine, the absorbed fractions are greater for the upper portions of the uterus where the legs and lower trunk of the fetus would normally be located. When the source organ is the lower large intestine contents, the absorbed fractions for the lower portion of the uterus would be greater. For photons of different energies the detailed results would differ qualitatively. At lower energies the uterus considerably attenuates the photons while at higher energies the absorbed fractions are approximately the same for the various parts of the fetus.

#### References

- (1) Snyder, W. S., et al. Estimates of absorbed fractions for monoenergetic photon sources uniformly distributed in various organs of a heterogeneous phantom. MIRD Pamphlet No. 5, J. Nucl. Med. 10 (1969).
- (2) Snyder, W. S., et al. A tabulation of dose equivalent per microcurie-day for source and target organs for an adult for various radionuclides. US-ERDA Report No. ORNL-5000, National Technical Information Service, Springfield, Va. (1974).
- (3) Loevinger, Robert, and Berman, Mones. MIRD Pamphlet No. 1, Revised, Society of Nuclear Medicine (1976).
- (4) Cloutier, Roger J., et al. Dose to the fetus from radionuclides in the bladder. Health Physics 25, 147-161 (1973).
- (5) International Commission on Radiological Protection Task Group of Committee 2. Report of the Task Group on Reference Man. Pergamon Press, New York (1975).
- (6) Cloutier, Roger J., Watson, Evelyn E., and Snyder, Walter S. Dose to the fetus during the first three months from gamma sources in maternal organs. In: Proceedings of Radiopharmaceutical Dosimetry Symposium, HEW Publication (FDA) 76-8044, U. S. Government Printing Office (1976).

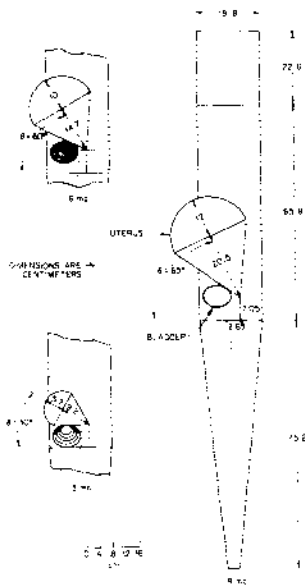

Fig. 1. Model of Pregnant Woman

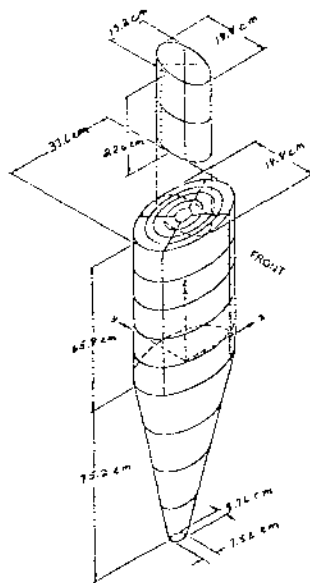

Fig. 2. Model of Reference Woman

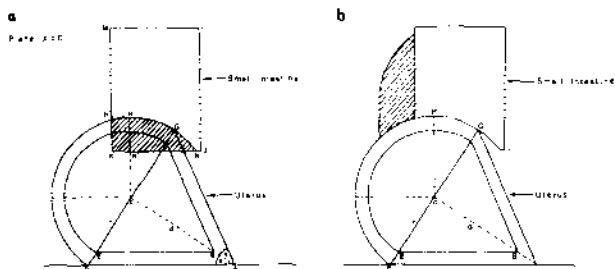

Fig. 3. (a) Model showing intersection of 3 mo. pregnant uterus and small intestine.  
 (b) Model of uterus and small intestine after transformation.

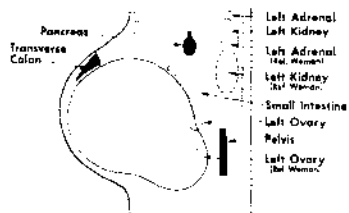

Fig. 4. Left sagittal view of abdomen of 9 mo. pregnant woman model. Dashed lines outline organ placement in nonpregnant model.

THE CHOISE OF A BIOLOGICAL MODEL IN ASSFSSING  
INTERNAL DOSE EQUIVALFNT

A. Parodo and N. Enne  
Istituto di Fisica,  
Università di Sassari,  
Italia.

Assessing the dose equivalent resulting from a known uptake of radioactive material is probably the most difficult feature of the whole radiation dosimetry. Besides doing direct bioassays, as whole body or organ counting, it is usually necessary to analyse excreta. This is because one can calculate the internal exposure from the amount of radioactive material in excreta and the excretion rate, by means of an appropriate biological model.

The kinetic behaviour of radionuclides within the organism or in an organ can be described by various models. This is true particularly for the metabolic kinetics of bone-seekers radionuclides, for which different retention functions derived from different models have been proposed.

One finds retention expressed either by an exponential equation, or by a power equation, or by an exponential and power equation. Retention function expressed as linear combination of exponential terms are obtained by coherent compartmental analysis and allow a mathematical formalism fairly well definite and easily adaptable to computer. Moreover, it is possible to use extant graphs and nomograms (1) which facilitate the calculations of internal exposure. Because of the complexity of the metabolic processes of the bone tissue, five or six exponential terms may be required to fit experimental data. However, it is possible to use less parameters by expressing retention as power function or by a more complicated function with exponential and power terms. Even so, the calculations of internal exposure become more complicated and time consuming.

In the model developed by the Task Group of the Committee 2 of the ICRP (2) to explain the metabolism of alkaline earth radionuclides, retention is expressed by an exponential and power equation. This model is very realistic and takes into account the essential features of the biological processes which take place in the tissues. Nevertheless, estimates of internal dose equivalent in the organism or in an organ are

difficult and time consuming.

Other authors have used multicompartmental models to explain the metabolism of these nuclides: exponential retention are reported, e.g., for calcium (3) and radium (4), injected intravenously in man. We ourselves (5) have developed a four compartment model for radium metabolism, using virtually all of the existing data as reanalysed by the Task Group of Committee 2 of the ICRP. The whole body retention is plotted in Fig. 1, while Fig. 2 shows the plasma retention per gram calcium. The values of parameters of the retention equations

$$R = \sum k_n \exp(-b_n t)$$

are reported in table 1. The model is very simple and fits well the experimental data; calculation of internal exposure is easy and rapid in any case, and it becomes immediate when one makes use of the graphs or nomograms of ref. 1.

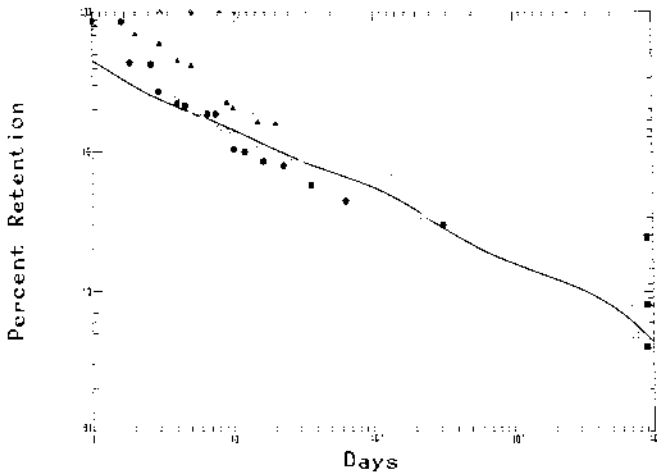

Fig. 1. Radium retention in whole body. Data: ○ Harrison (6); □ Schindt (7); □ Norris (8); ■ Miller (9); ▲ Mays (10); ● Mays (2); ▲ Maletskos (11). Practically all data available for adult man, as reanalysed by the Task Group of the ICRP (2), are reported.

Internal exposure values for 1, 50 and infinite years after injection are reported in table 2, which compares the values obtained with three most recent models. It shows that our results are within 8% of those obtained by the Task Group of the Committee 2 of ICRP, while the others obtained following the



use of the five compartment model, reported in the ICRP Publication 10A (4), are substantially different.

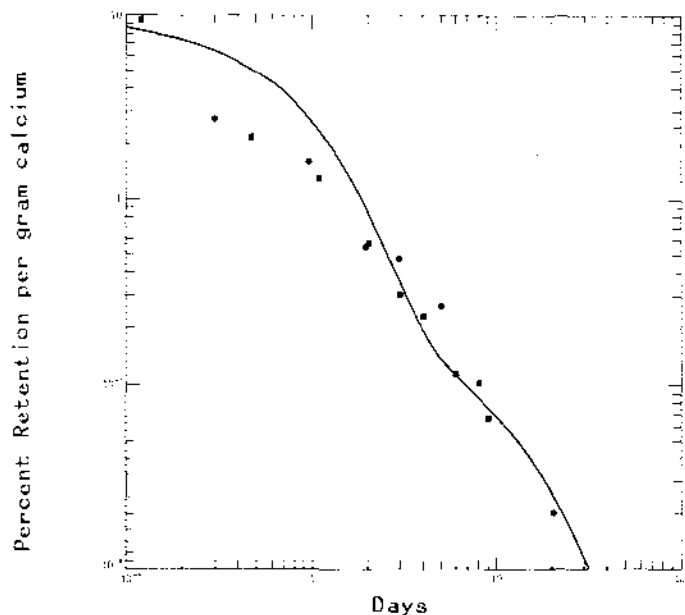

Fig. 2. Radium retention per gram calcium in blood plasma. Data: ■ Harrison (6); ○ Mays (10); ● Mays (2); □ Maletskos (11). Data are reported following reanalysis of the Task Group of the Committee 2 of the ICRP.

n	b <sub>n</sub>	k <sub>n</sub>				
		Whole body	Blood	Exchangeable bone	Deep bone	Soft tissue
1	1.300	0.730	$2.8 \cdot 10^{-2}$	-0.133	-0.0133	0.847
2	0.112	0.177	$5.9 \cdot 10^{-4}$	0.136	-0.0058	0.046
3	0.0062	0.075	$1.4 \cdot 10^{-5}$	$5.7 \cdot 10^{-4}$	0.0044	0.070
4	0.00015	0.018	$0.8 \cdot 10^{-7}$	$3.2 \cdot 10^{-6}$	0.0163	0.0017

Table 1. Parameters of the retention functions of the four compartments model. Of course, only 8 of them are independent. Whole body and plasma retention are plotted in figures 1 and 2.

The choice of the model appears therefore less important than the determination of the appropriate value of the parameters. However, the most interesting deduction derived from the comparison is that results obtained with a simple multicompartamental model are practically the same obtained with the model proposed by the Task Group of the ICRP, which is, formally at least, much more complex. On the other hand, the role of the biological model in internal dosimetry must be referred to the reliability of the quantitative informations on the kinetic behaviour of the radionuclides in an organism only in relation to the accuracy of the doses calculated. After all, from the point of view of the internal dosimetry, each biophysical model is good when allows to obtain good estimates of dose with simple calculations.

Time (Ys)	Whole body	Blood	Surface bone	Deep bone	Soft tissue	Model
1	30.8	(0.0284)	--	--	--	1971 (4)
	18.8	0.0288	1.16	7.15	10.8	1973 (2)
	19.4	0.0290	1.19	6.37	11.7	1977 (5)
50	183.3	(0.0298)	--	--	--	1971 (4)
	119.0	0.0296	1.19	97.5	21.2	1973 (2)
	126.5	0.0298	1.22	102.5	22.7	1977 (5)
$\infty$	194.4	(0.0299)	--	--	--	1971 (4)
	147.7	0.0297	1.19	125.1	21.5	1973 (2)
	134.2	0.0298	1.23	109.5	23.4	1977 (5)

Table 2. Internal exposure due to a single uptake of 1  $\mu$ Ci of  $^{226}\text{Ra}$  in  $\mu\text{Ci}\cdot\text{days}$  for 1, 50 and infinite years after injection. The values written between brackets are not reported in Ref. 4; they have been calculated by means of eq.:

$$R_{\text{Blood}} = -0.0299 (dR_{\text{Whole-body}}/dt)$$

based on the postulate that number of radioactive atoms excreted from the body per unit time is proportional to the number in the plasma at that time.

#### REFERENCES

- (1) Parodo, A., II Riv. Scient. Plen. SIBPA, Vallombrosa (1975).  
Parodo, A., Erre, N., I° Conv. Naz. Fis. Sanit. SIRMN, Milano (1976).
- (2) ICRP Publication 20. Pergamon Press, Oxford (1973).
- (3) Cohn, S.H., and Al; Radiat. Res. 26, (1965) 319.
- (4) ICRP Publication 10A, Pergamon Press, Oxford (1971).
- (5) To be published.
- (6) Harrison, G.E., et al., Int. J. Radiat. Biol. 13 (1967) 235.
- (7) Schlundt, H., et al., Am. J. Roentgenol. Rad. Therapy, 30 (1933) 515
- (8) Norris, W.P., et al., Am. J. Roentgenol. Rad. Therapy 73 (1955) 785

- (9) Miller, C.E., Finkel, A.J. Ann. report ANL 7217 (1965) 7.  
Miller, C.E., Finkel, A.J. Am. J. Roentgenol. Rad. Therapy  
and Nucl. Medicine 103 (1968) 871.
- (10) Mays, C.W., et al., Radiat. Res. 19 (1963) 210.
- (11) Maletskos, C.J., et al., Ann. Report MIT 952-3 (1966) 202.

MICRODOSIMETRY OF  $^{129}\text{I}$  IN THE HUMAN THYROID

Y. Feige  
Soreq Nuclear Research Centre  
Yavne, Israel

and

A.P. Kushelevsky  
Ben-Gurion University of the Negev  
Beer-Sheva, Israel

1. INTRODUCTION

Iodine-129 is produced in nuclear fission with a yield of about 1%. Because of its long half-life of 15.7 million years,  $^{129}\text{I}$  is a potential long-range health hazard in and around fuel reprocessing plants (1-3). The effect of the *non-uniform* distribution of  $^{129}\text{I}$  within the thyroid gland on the dose reaching the cell nuclei will be examined.

2. PHYSICAL DATA FOR  $^{129}\text{I}$

$^{129}\text{I}$  transforms to the 39.5 keV excited state of  $^{129}\text{Xe}$  by beta decay (maximum energy 150 keV), which in turn decays to its ground state mainly by internal conversion, as shown in Table 1 (4). The average decay energy of the entire process is 87.9 keV, of which 48.4 keV is associated with the beta decay, 24.9 keV with the uncovered  $\gamma$  and X-rays, and about 14.6 keV per disintegration is carried by conversion and Auger electrons.

$^{129}\text{I}$  - 129  
BETA-MINUS DECAY  
 $^{129}\text{I}$   
 $^{129}\text{I}$

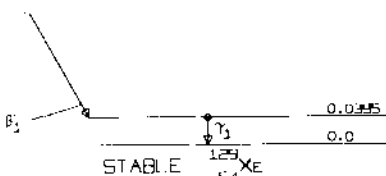

\*\*\*INPUT DATA\*\*\*

53 IODINE 129      HALF LIFE = 15.7 MEGAYEAR

DECAY MODE= BETA MINUS

TRANSITION	MEAN NUMBER/DISINTEGRATION	TRAN-SITION ENERGY (MEV)	OTHER NUCLEAR DATA
BETA MINUS 1	1.0000	0.15000	U 1ST FORBIDDEN
GAMMA 1	1.0000	0.0395	M1, AK=10.0 K/IL=11.0, B,BO

ENDPOINT ENERGY (MEV).

REF. - LEDERER, C.N. ET AL, TABLE OF ISOTOPIES, 8TH, ED.

\*\*\*OUTPUT DATA\*\*\*

53 IODINE 129      HALF LIFE = 15.7 MEGAYEAR

DECAY MODE= BETA MINUS

RADIATION	MEAN NUMBER/DISINTEGRATION	MEAN ENERGY/PHOTOELECT	EQUILIBRIUM DOSE CONSTANT
	$n_i$	$E_i$ (MeV)	$A_i$ (μCi-h)
BETA MINUS 1	1.0000	0.0484	0.1032
GAMMA 1	0.0801	0.0395	0.0047
K INT CON ELECT	0.4018	0.0050	0.0085
L INT CON ELECT	0.0684	0.0345	0.0045
M INT CON ELECT	0.0294	0.0386	0.0024
K ALPHA-1 X-RAY	0.3814	0.0297	0.0241
L ALPHA-2 X-RAY	0.1968	0.0294	0.0123
K BETA-1 X-RAY	0.1052	0.0336	0.0079
K BETA-2 X-RAY	0.0221	0.0345	0.0016
L X-RAYS	0.1134	0.0041	0.0009
KLL AUGER ELECT	0.0639	0.0244	0.0033
MLX AUGER ELECT	0.0277	0.0285	0.0016
KXY AUGER ELECT	0.0045	0.0326	0.0003
LMM AUGER ELECT	0.7087	0.0031	0.0048
KXY AUGER ELECT	1.7076	0.0009	0.0033

TABLE 1 Data for  $^{129}\text{I}$  (4)

### 3. THE BIOLOGICAL MODEL OF THE THYROID

Essentially the same model of the thyroid assumed previously for the microdosimetry of  $^{125}\text{I}$  will be applied (5-7), taking into account the recent ICRP data regarding the anatomy and physiology of the thyroid (8). The main features of the model are:

(a) The thyroid is composed of closely packed spherical follicles. Each follicle is approximated by two concentric spheres. The inner sphere contains a water equivalent colloid gel in which 90% of the iodine is stored. The other 10% is distributed uniformly outside the colloid fraction.

(b) The inner sphere is surrounded by a layer of closely packed cells, whose outer surface defines the follicle boundary. The cell nuclei, which constitute the radiosensitive target, lie about  $3\mu$  from the colloid/cell interface (Fig. 1).

(c) The normal adult thyroid, 50% of which is colloid, weighs 20g and contains 12 mg iodine.

(d) The average diameter of the follicles depends on age, ranging from  $60\mu$  in the newborn to about  $300\mu$  in the adult (8). The size of the cells, however, remains the same,  $10\mu$ , regardless of age.

Our model is a rough approximation, as there is much variation in follicle size, shape, and concentration of iodine from follicle to follicle even in the same thyroid gland (9).

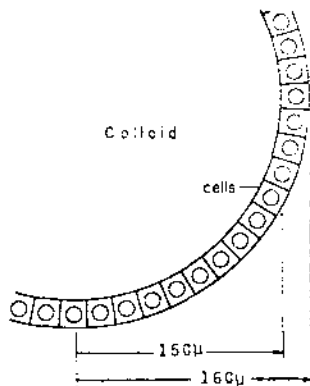

Fig. 1. Model of an adult thyroid follicle.

### 4. REVISED DOSIMETRY OF UNIFORM DISTRIBUTION OF $^{129}\text{I}$ IN THE THYROID

Assuming 12 mg  $^{129}\text{I}$  of maximum specific activity ( $173 \mu\text{Ci/g}$ ) is distributed uniformly in 20 g of thyroid tissue, it can readily be shown, allowing for the partial escape of the photon component (10), that the dose to the thyroid will be 129 rad/y\*.

\*W.S. Snyder et al. in: NM/MIRD, Pamph.11, p.181, 1975, give a value of 122 rad/y.

Hence if 23 p.p.m. of the iodine in the thyroid is  $^{129}\text{I}$  the dose delivered to it will be 3 mrad/y. This concentration is about half that derived by Soldat (1) and Palms (2) who assumed only 7 mg I per 20 g thyroid.

#### 5. DOSIMETRY FOR NON-UNIFORM $^{129}\text{I}$ DISTRIBUTION IN THE THYROID

The previous average dose calculation does not take into account the fact that a significant portion of the energy released by  $^{129}\text{I}$  is carried by low energy electrons with ranges smaller than the average dimensions of the thyroid follicle. Since 90% of the  $^{129}\text{I}$  is assumed to be within the colloid, not all of the emitted energy can reach the cell nuclei. Dose distribution calculations of the  $^{129}\text{I}$  localized in the colloid were performed using methods and assumptions similar to those applied previously to  $^{125}\text{I}$  (5-7,11). These calculations, also include the contribution of dose from adjacent follicles in three dimensions, assuming maximal close packing. The calculations are described in detail elsewhere (12). The average dose at the cell nucleus,  $3\mu$  from 1  $\mu\text{Ci}$   $^{129}\text{I}$  in the colloid fraction, as derived from our calculations is given in Table 2.

Dose component	rad/y
$^{129}\text{I}$ $\beta$ decay	29.8
$\beta$ dose from adjacent follicles	7.0
X and $\gamma$ component	7.0
Auger and conversion electrons	2.3
Total dose	46.1

TABLE 2: Average dose to cell nucleus from 1  $\mu\text{Ci}$   $^{129}\text{I}$  in the colloid fraction of the adult thyroid gland (12).

#### 6. RESULTS AND CONCLUSIONS

According to our assumptions, the average dose to the cell nucleus in the adult thyroid from 2  $\mu\text{Ci}$   $^{129}\text{I}$ , corresponding to its maximum possible specific activity (137  $\mu\text{Ci}$   $^{129}\text{I}/\text{g}$  I), is:

$$1.6 \times 46.1 + 0.2 \times 129 = 73.8 + 25.8 = 99.6 \text{ rad/y}$$

This is 77% of the dose calculated without taking into account the micro-distribution of iodine within the thyroid gland. Recent publications (9) indicate that the nuclei of the cells may lie even further away from the colloid-cell interface than postulated by our model. This will cause the dose at the nuclei to be even lower. A rough estimate indicates that if we double the nucleus-interface distance to 6  $\mu$ , the yearly dose to the nucleus will be of only  $\sim 75$  rad.

As in the case of  $^{125}\text{I}$  the assumption that  $^{129}\text{I}$  is uniformly distributed in the thyroid gland results in an *over-estimation* of the average dose to the cell nuclei.

In order to avoid exposures exceeding 3 m rad/y to the thyroid the long-term concentration of  $^{129}\text{I}$  in the environment should remain below 23 p.p.m. of stable iodine ( $^{127}\text{I}$ ).

#### REFERENCES

- (1) SOLDAT, J.K., Health Phys. 30, (1976), 61.
- (2) PALMS, J.M., et al., Nucl. Safety 16, (1975) 593.
- (3) HUBSCHMANN, W.G., Health Phys. 30, (1976) p. 496.
- (4) DYLLMAN, L.T. and VAN DER LAGE, F.C., NM/MIRD Pamphlet No. 10, (1975), 73.
- (5) FEIGE, Y., et al., In: Proc. Symp. Biophys. Aspects Radiat. Quality, Sydney 1971, IAEA, Vienna (1971), p. 383.
- (6) GAVRON, A. and FEIGE, Y., Health Phys. 23, (1972) 491.
- (7) FEIGE, Y. and GAVRON, A., In: Radiation Research, Biomedical Chemical and Physical Perspectives, Academic Press, N.Y. (1975) 557.
- (8) ICRP Pub. 23, Pergamon Press, pp 196-200; p. 287. (1975)
- (9) MALONE, J.F., Current Topics in Radiation Research Quarterly, 10, (1975) p 263.
- (10) SNYDER, W.S., et al., NM/MIRD Pamphlet No. 5, (1969) p 42.
- (11) VALLEY, J.F., KUSHELEVSKY, A.P. and LERCH, P., Health Phys. 26, (1974) p. 295.
- (12) FEIGE, Y. and KUSHELEVSKY, A.P., 1977 (to be published).

En mettant sous presse nous avons appris avec tristesse le décès de M. Y FEIGE. Cet éminent scientifique avait beaucoup contribué au développement de la Radioprotection.

EXPERIMENTAL EVALUATION OF ORGAN DOSES FROM EXPOSURE TO  
Tc-99m, I-123 and I-131

Thomas Grönberg, Bertil Persson and Sven-Erik Strand  
Radiation Physics Department  
Lasarettet, S-221 85 LUND, Sweden

### 1. INTRODUCTION

Recently the MIRD committee formulated a new quantity "S" defined as the absorbed dose per unit cumulated activity. This quantity has been tabulated in MIRD PAMPHLET No 11 for various radionuclides and source-target configurations of a standard man (1). We have partly calculated the corresponding values by an alternative method using direct attenuation and build-up equations for point sources and partly studied experimentally the quantity "S" for Tc-99m, I-123 and I-131.

The calculation approach adopted offers the possibility both to examine the dose-gradients in the target organs and to calculate the average "absorbed dose per unit cumulated activity" as given by MIRD, and further to normalize a real case to correlate the standard situation from which the "MIRD" values are evaluated.

### 2. CALCULATIONS

We have chosen an alternative way of calculating the absorbed dose in the target organs which is based on the expression (2):

$$D(r) = \int_0^t A_0 e^{-\lambda t} dt \cdot \Delta \cdot \frac{\mu_{en}}{\rho} \frac{1}{4\pi r^2} \cdot e^{-\mu r} \cdot B(\mu r) \quad 1.$$

This equation gives us the absorbed dose at a point from a point isotropic source within an infinite homogeneous medium where  $B(\mu r)$  is based on Bergers formula for calculation of the energy absorption build-up factor (2).

The organ in question is divided into a number of small volume elements which are approximated to points. The calculation proceeds until each volume element in the target organ has achieved a contribution from each volume element in the source organ. The absorbed dose can be written as

$$D(r_k + r_h) = \frac{\sum_{i=1}^n D(r_i)}{n} \quad 2.$$

Where  $n$  is the product of the number of volume elements in the target and source organs.

### 3. THE PHANTOM MODEL

The phantom model is in all important aspects in agreement with the mathematical description according to MIRD Pamphlet No 5. The soft-tissue is simulated by perspex and water and the skeleton by aluminium. The volume of the skeleton is corrected so that the electron density is in agreement



with that of the theoretical MIRD phantom.

Every organ (except the lungs) is constructed in one target version and one source version. The target organ version is divided into a number of planes parallel to the xy-plane where the mathematical equation of the organ is fulfilled in each plane. The lungs are constructed of corkplates with a density of 0.28 g/cm<sup>3</sup>.

All the source- and target organs are fixed on the Al-tube which simulates the backbone.

#### 4. MEASUREMENT OF ABSORBED DOSE

The absorbed dose measurements were performed using extruded LiF-TL-dosimeters packed in sealed thin plastic bags.

The dosimeters were placed in planes parallel to the xy-plane at various depth z in the target organ of interest.

The experimental set up is then inserted into the waterfilled phantom body. The radionuclide in question is injected into the sourceorgan and the dosimeters are exposed for time t. Then the phantom is emptied of water and the dosimeters are evaluated.

#### 5. EVALUATION OF AVERAGE ABSORBED DOSE

Consider a mass element  $dm = P(z) \cdot dz \cdot \text{density}$ , where  $P(z)$  is the cross-sectional area of the plane parallel to the xy-plane at height z in the target organ.

Then the average absorbed dose  $D(z)$  in the mass element  $dm$  can be expressed as:

$$\bar{D}(z) = \left( \frac{e \cdot E \cdot R}{\rho} \right)_{\text{LiF}} \cdot Z \cdot C \cdot \frac{k}{CE} \cdot \frac{\sum R(i)}{n} \quad 3.$$

Where  $R(i)$  represent the response from dosimeter i on the plane at level z, k is the calibration constant (rad/scale reading) for the whole group of dosimeters and CE is the correction coefficient for the energy dependence of the dosimeters. The weighted average absorbed dose for the whole organ is calculated from equation 4 given below. This corresponds to the theoretical absorbed dose  $D(r_k + r_h)$  according to MIRD.

$$\bar{D}(r_k + r_h) = \frac{\sum \bar{D}(z) \cdot P(z)}{\sum P(z)} \quad 4.$$

Where the sum is taken over all measured depths in the target organ.

The absorbed dose per unit cumulated activity (rad/Ci-h) is derived from the expression .

$$S(r_k + r_h) = \frac{\bar{D}(r_k + r_h)}{A_0 \int_0^t e^{-\lambda t} dt} \quad 5.$$

#### 6. RESULTS AND DISCUSSION

The variation of absorbed dose and absorbed dose per unit cumulated activity of the radionuclides Tc-99m, I-123 and I-131 have been determined both

by experiments and calculations using bladder, liver and kidneys as source organs and kidneys, liver, lungs and ovaries as target organs. The overall uncertainty in the experimental determination of "S" was estimated to be about 20 % or less.

### 6.1 Comparison of absorbed dose per unit cumulated activity

The theoretical values given by MIRD (SM) and our calculated (SC) and experimental (SE) values are thus compared for various configurations of source and target organs. In table 1 the "S" values for kidneys and ovaries with Tc-99m in the liver are given and in table 2 the "S" values for liver, lungs and ovaries with the kidneys as source organs are given for both I-123 and I-131. As can be seen from these tables both our calculated and measured values are in good agreement with the values obtained by Monte Carlo calculations by MIRD committee. Our method of calculation can also be used for any radionuclide to normalize the "S"-values given by MIRD to various body shapes which differ significantly from the standard situation. This is achieved in the following way  $SN = SQ * (SM/SC)$  where SN is the normalized value and SQ is the calculated value for the case in question.

### 6.2 The variation of absorbed dose within the target organ

In order to get an idea of the significance of the variation in absorbed dose within the target organ we have calculated the unweighted average absorbed dose  $\bar{D}$ , and the range R between maximum and minimum values of absorbed dose and the ratio  $R/\bar{D}$ .

The results of these calculations are given in Table 3 for the liver and the ovaries with the kidneys as source organs. It can be noted from this table that  $\bar{D}$  for I-123 is only about half of that for I-131. The relative spread however is the same in the liver for the radionuclides considered but within the ovaries it is slightly higher for I-123 than for I-131.

Target organ	Sourceorgan: Liver		
	Tc-99m		
	SM rad/Ci-h	SC rad/Ci-h	SE rad/Ci-h
Kidney R	/	7.5	8.4 $\pm$ 1.7
Kidney L	/	1.6	2.1 $\pm$ 0.4
Kidneys AV	3.9	4.6	5.3 $\pm$ 1.0
Ovary R	/	0.83	0.72 $\pm$ 0.1
Ovary L	/	0.45	0.35 $\pm$ 0.07
Ovaries AV	0.45	0.64	0.54 $\pm$ 0.1

TABLE 1 The absorbed dose per unit cumulated activity given by MIRD SM, calculated SC, and experimentally measured SE for kidneys and ovaries with Tc-99m in the liver

Targetorgan	Sourceorgan:Kidneys					
	I-123			I-131		
	SM rad/Ci-h	SC rad/Ci-h	SE rad/Ci-h	SM rad/Ci-h	SC rad/Ci-h	SE rad/Ci-h
Liver	5.1	5.4	6.0 <sup>±</sup> 1.2	11.0	13	1.2 <sup>±</sup> 2.4
Lungs	1.0	/	1.0 <sup>±</sup> 0.2	2.5	/	3.1 <sup>±</sup> 0.6
Ovaries	1.3	1.9	1.4 <sup>±</sup> 0.3	3.4	3.7	4.2 <sup>±</sup> 0.8

Table 2 The absorbed dose per unit cumulated activity partly given by MIRD SM partly calculated SC and determined experimentally SE in the present work for liver lungs and ovaries with I-123 and I-131 in the kidneys.

Target organ	Statistical measure	Sourceorgan:Kidneys			
		I-123		I-131	
		C	E	C	E
Liver	$\bar{D}$  rad	3.86	4.20 <sup>±</sup> 0.8	10.2	9.61 <sup>±</sup> 1.9
	R  rad	17.7	17.9 <sup>±</sup> 4.0	41.6	40.0 <sup>±</sup> 8.0
	R/ $\bar{D}$	4.58	4.26 <sup>±</sup> 1	4.37	4.16 <sup>±</sup> 2.5
Ovaries	$\bar{D}$  rad	2.10	1.51 <sup>±</sup> 0.3	3.91	4.50 <sup>±</sup> 0.9
	R  rad	2.00	1.40 <sup>±</sup> 0.3	2.33	2.50 <sup>±</sup> 0.6
	R/ $\bar{D}$	0.95	0.93 <sup>±</sup> 0.5	0.60	0.56 <sup>±</sup> 0.3

TABLE 3 The average absorbed dose  $\bar{D}$  and the range R between the maximum and minimum value of absorbed dose in liver and ovaries with I-123 and I-131 in the kidneys (cumulated activity 1 Ci-h)

#### REFERENCES

- (1) MIRD Pamphlet No 5
- (2) MIRD Pamphlet No 2
- (3) MIRD Pamphlet No 11

## DOSE CALCULATIONS FOR INFANTS AND YOUTHS DUE TO THE INHALATION OF RADON AND ITS DECAY PRODUCTS IN THE NORMAL ENVIRONMENT

W. Hofmann, F. Steinhäusler  
 Institute of Physics, University of Salzburg,  
 Akademiestraße 26, 5020 Salzburg, Austria

## 1. INTRODUCTION

$^{222}\text{Rn}$  and its decay products in the atmosphere of normal working- and living rooms contribute to parts of our respiratory tract the highest radiation burden from all the natural radioactive environment (1, 2). The base of today's lung dose calculations are the physiological data of the ICRP-Reference Man (3) and the deposition and retention models of the ICRP-Task Group on Lung Dynamics (4). Both deal extensively with the problems associated with the adult, but much less consideration is given to the physiological properties of the growing organism and none to the resulting radiation dose. The aim of this paper was to determine the influence of age-dependent variables on dose calculations.

## 2. PHYSIOLOGICAL DATA

In general few data are available on the change of physiological parameters in dependence of age, except for the new data published by Hötter (5). Furthermore the published data show large differences for one and the same parameter. For our calculations we defined age dependent parameters, comprising geometrical dimensions of lung parts as well as respiratory standards. Due to the lack of data, resp. for the interpolation of missing data from published results the following assumption was made: the lung of a child is the miniature version of the fully developed lung of an adult. Whenever large differences were found in the literature for one and the same parameter, either a mean value was calculated or the single values were fitted to a monotonously increasing function. In general the curves of most lung parameters showed the same tendency: steep increase during the first 10 years of life and continuing slowly into a saturation curve with the end value (age 30 years) represented by data for the Reference Man.

## 3. DEPOSITION PROBABILITIES

Due to the different geometry of the respiratory tract of an adult as compared to a child, there is also a change in the flow conditions and deposition probabilities. For all calculations the Landahl-lung model was used, since there were too many physiological age dependent data missing in order to use the more detailed Weibel-lung model. For the calculations of the deposition probabilities in the various regions of the respiratory tract, the Landahl method (6) was applied with minor alterations. The calculations were based on the following reference atmosphere:

activity median aerodynamic diameter (AMAD) of attached nuclides:  
 0.2  $\mu\text{m}$   
 AMAD of unattached nuclides (8.5% of RaA, 1.0% of RaB, 0.6% of RaC):  
 0.001  $\mu\text{m}$

The results of these calculations showed that - despite the large geometrical changes of the growing organism - both the absolute values (for a defined

respiratory minute volume, RMV) and the distribution within the single regions differed only slightly from the values for an adult. In general the functions for the deposition probability of the different nuclides show a decline during the first few years, approximating a constant value later on. In accordance to the assignment of the various regions to the ICRP-lung model compartments, the calculated regional deposition probabilities were summed up over the compartments.

#### 4. RADIOACTIVITY INHALED

For the determination of the inhaled radioactivity, age dependent daily life patterns were defined. With respect to the individual physical activity, influencing the RMV to a large extent, these life patterns were divided into periods of rest, light and heavy work. Furthermore the percentage of time spent indoors and outdoors was considered, since the atmospheric nuclide concentration within buildings is increased as compared to outdoors. In this manner the annual inhaled radioactivity was calculated for different ages. Fig. 1a, b represent these activity functions for 2 extreme cases showing large differences of the annual inhaled activity. For children and youths no differences in individual physical activities were assumed.

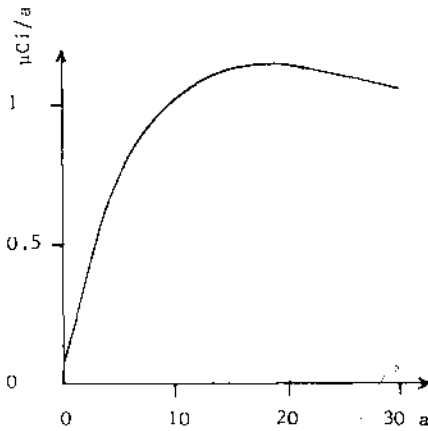

FIG. 1 a

Annual Inhaled Radioactivity due to Rn under Favourable Conditions:  
Rn concentration:  
 indoors: 0.1 pCi/l  
 RaA:RaB:RaC = 0.9:0.6:0.4  
 outdoors: 0.1 pCi/l  
 RaA:RaB:RaC = 0.9:0.5:0.4  
Adult physical activity: light work

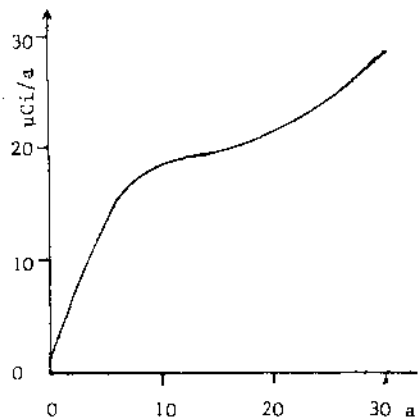

FIG. 1 b

Annual Inhaled Radioactivity due to Rn under Disadvantageous Conditions:  
Rn concentration:  
 indoors: 2.0 pCi/l  
 RaA:RaB:RaC = 1:0.7:0.5  
 outdoors: 0.5 pCi/l  
 RaA:RaB:RaC = 1:0.6:0.5  
Adult physical activity: heavy work

## 5. AGE DEPENDENT DOSE CALCULATIONS

With the use of a hybrid computer the influence of age-dependent deposition probabilities and activity functions were investigated for the steady-state activities in the single compartments. Since there are no data available for the age dependence of the clearance processes, a possible age dependence was studied by varying single parameters. Experiments with animals and man revealed, that the half life of 0.5 days for the transport from pulmonary compartment region to blood of the revised ICRP-clearance model (7) is far too large and the true value is less or equal 30 mins (8, 9). Applying the smaller value for the half life the activity within the pulmonary compartment is reduced approximately by a factor 2.

Considering the age dependence of the mass of the tracheobronchial (TB) and Pulmonary compartment (P), the integral  $\alpha$ -dose was calculated. Fig. 2 a, b represent the dose in dependence of age, for the TB- and P-compartment using the activity functions as defined in Fig. 1 a.

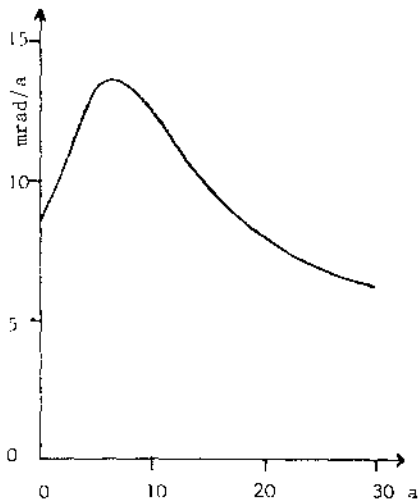

FIG. 2 a

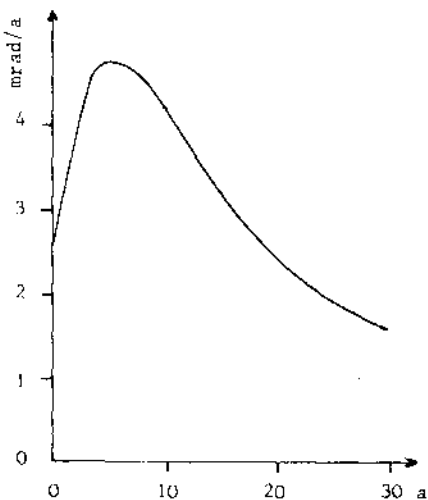

FIG. 2 b

Integral  $\alpha$ -Dose (mrad/a) in Dependence of Age (a) for the Tracheobronchial (TB)- and Pulmonary (P)-Compartment

For both compartments there is a significant maximum dose, which is received at the age of about 6 years. It is approximately 2 - 3 times higher than the corresponding dose of an adult. The calculations for the disadvantageous conditions (see Fig. 1 b) revealed that up to the age of about 16 years the shape of the dose curves for TB- and P-compartment is similar as for the favourable conditions, but with no further decrease with progressing age. Again the maximum dose is reached at the age of 6 years, however, the values are 313 mrad/a and 101 mrad/a for the TB- and P-compartment.

In all calculations we determined only the integral dose according to the ICRP-compartment model. Within the tracheobronchial compartment, however,

there is a very non-uniform  $\alpha$ -dose distribution. From studies on adults it is known that the highest dose is received by the basal cells of the segmental and subsegmental bronchi (10). In the case of children and youths the different geometrical dimensions (e. g. thickness of mucus and cell layers) and different physiological processes (e. g. ciliary-movement) have to be taken into consideration. Further detailed calculations are in progress concerning this problem.

In some special cases (e. g. in regions of Brazil and India) also the atmospheric content of  $^{220}\text{Rn}$  and its decay products in the environment is not negligible. Calculations will be extended to this problem as well.

## 6. CONCLUSIONS

From our results it can be seen that there is a pronounced age dependence of the integral  $\alpha$ -dose to the lung due to inhalation of Rn and its decay products. A maximum dose is reached at the age of about 6 years. This dose is up to a factor 3 higher than the corresponding dose value for an adult, living under the same conditions.

Therefore lung dose calculations of a given population for radiation protection purposes should rather consider age dependence than using a "reference man" as a representative for the whole population.

## REFERENCES

- (1) POHL, E., et al., Biological and Environmental Effects of Low-Level Radiation, Vol. II (Proc. Symp. Chicago, 1975), IAEA (1976) 305
- (2) STEINHÄUSLER F., et al., Proc. Health Phys. Soc. Tenth Midyear Topical Symp. on Nat. Radioact. in Man's Environ., Saratoga Springs, New York (1976)
- (3) Report of the Task Group on Reference Man, ICRP No. 23 (1975)
- (4) Task Group on Lung Dynamics, Health Phys. 13 (1967) 1251
- (5) HÖTTER, G. J., Die Lungenfunktion unter besonderer Berücksichtigung des wachsenden Organismus, Steinkopff Verlag (1975)
- (6) LANDAHL, H. D., Bull. Math. Biophys. 12 (1950) 43
- (7) JACOBI, W., Health Phys. 23 (1972) 3
- (8) POHL, E., et al., Strahlentherapie 136 (1968) 738
- (9) POHL, E., et al., Health Phys. 31 (1976) 343
- (10) HARLEY, N., et al., Health Phys. 23 (1972) 771

INFLUENCE OF AGE AND MODE OF RADIOIODINE EXPOSURE  
ON THYROIDAL RADIOLOGIC DOSE\*

Steven A. Book

Radiobiology Laboratory, School of Veterinary Medicine  
University of California, Davis, California 95616 USA

Isotopes of iodine released to the environment from nuclear power-related operations may easily enter the human body, either by inhalation of contaminated air or by ingestion of contaminated foods, and ultimately deposit in the thyroid gland. Inhalation is an important route of exposure for all radioiodines, in particular those with physical half-lives (Tp's) of less than one day, such as  $^{130}\text{I}$ ,  $^{132}\text{I}$ ,  $^{133}\text{I}$ , and  $^{135}\text{I}$ . Ingestion is a more significant route for those radioiodines with longer Tp's. Iodine-131 (Tp = 8 days) passes from atmosphere to man by the vegetation → cow → milk pathway. The longest-lived radioiodine,  $^{129}\text{I}$  (Tp = 16 million years), assumes an essentially permanent residence in the environment upon its release, and may reach man by several dietary pathways (2,8).

The radioiodines are readily transported across biological membranes. Hence, the thyroid glands of fetuses and children may be exposed to radioactivity as a result of the ease with which these radionuclides cross the placenta and mammary gland, respectively.

The thyroid is intimately involved in growth and development, and actively concentrates iodine as required for its hormonogenic processes. Since metabolism changes with age, so, too, will the pattern of thyroidal radioiodine uptake and retention. Similarly, respiration rates vary with age, and dietary requirements and habits change, thus altering the potential for radioiodine assimilation from these routes.

As a result of age-related differences in both intake and metabolism of radioiodine, radiologic doses to the thyroid glands of young and mature individuals from the same environmental exposures will differ. This paper assesses the relationship of age and thyroidal irradiation as a result of acute radioiodine exposures, with the intent to identify the potentially more susceptible members of the population.

METHODS

Data on iodine metabolism for humans or derived from animal studies have been utilized to estimate thyroidal doses following acute exposure to  $^{131}\text{I}$ ,  $^{132}\text{I}$ , and  $^{133}\text{I}$ . Data on milk consumption and respiration (6) were utilized to provide appropriate input values for ingested or inhaled radioiodine, respectively. Age groups considered include fetuses in the 13th, 20th, and 32nd week of gestation, infants, 5-, 10-, and 15-year-old children, and adults. Some of the parameters used in this paper are presented in Table 1.

Thyroidal uptakes for  $^{131}\text{I}$  for adults and children 2-months-old and older were assumed to be 30% (4,9). Fetuses were assumed to concentrate 0.7, 6.4, and 9 times the maternal concentration in the 13th, 20th and 32nd week of gestation, respectively, based upon maximal values from animal and human data (3). Uptakes for  $^{132}\text{I}$  (Tp = 2.3 hours) and  $^{133}\text{I}$  (Tp = 20.8 hours) were calculated to reflect their increased rate of decay. Uptakes used were 6% for  $^{132}\text{I}$  and 11% for  $^{133}\text{I}$ , with values for fetuses altered by the same proportions as for  $^{131}\text{I}$ . Uptake of inhaled radioiodine was 77% of that from ingestion (4).

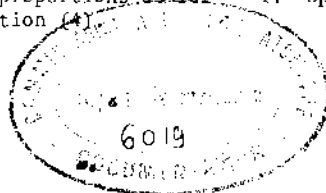



Biological half-lives ( $T_b$ 's) of 100 days for adults (5), 50 days for 10- and 15-year-olds, and 20 days in younger children (8) were assumed. Fetuses were assumed to have  $T_b$ 's of one day at 13 weeks and 4 days at 20 weeks based upon human data (1). Those in the 32nd week of gestation were assumed to have a longer  $T_b$  than younger fetuses based upon unpublished studies in guinea pigs and were assigned a  $T_b$  of 13 days.

## RESULTS AND DISCUSSION

The results of dosimetric calculations are presented in Table 2. Calculated doses, relative to those of adults, are presented in Fig. 1. One day's ingestion of milk containing  $^{131}\text{I}$  was calculated to result in differing radiologic doses to thyroid glands of various members of the population, reflecting both differences in iodine metabolism and variations in milk consumption. Under the assumed conditions, fetal thyroid glands were calculated to receive approximately 0.1, 2.5 and 6 times the dose of the thyroid of the adult male in the 13th, 20th and 32nd weeks of gestation, respectively. Thyroids of infants were calculated to receive the highest relative dose, approximately 30 times the adult dose for the 6-month-old. The higher dose arises from increased milk consumption to a maximum of 1 liter/day at 6 months of age. Thyroidal doses to 5-, 10- and 15-year-old children were determined to be about 5, 3 and 2 times the adult dose, respectively.

Inhalation of radioiodine would also lead to age-related variations in thyroidal dose. From inhaled  $^{131}\text{I}$ ,  $^{132}\text{I}$  and  $^{133}\text{I}$ , the thyroid of the 13-week-old fetus would receive less than the adult dose but up to 7 and 10 times that value at 20 and 32 weeks of age, respectively. Relative doses were higher for  $^{132}\text{I}$  and  $^{133}\text{I}$  than for  $^{131}\text{I}$ , since effective half-lives were similar for young and old alike with  $^{132}\text{I}$  and  $^{133}\text{I}$  but shorter for  $^{131}\text{I}$  in the young. Doses to the infant were up to 4 times the adult value; thyroidal doses declined with age to about 10% above the adult-value at 15 years of age.

These calculations show that, from exposure to environmental radioiodines, there may be considerable differences in the thyroidal dose among various members of the population. Young infants appear to be the cohort which would receive the greatest potential radiologic dose to the thyroid gland from ingested  $^{131}\text{I}$ . Their dose was calculated to be ~30 times the adult dose, or more than 5 times that of near-term fetuses. The near-term fetus on the other hand, receives the highest relative thyroidal dose from inhaled radioiodines, up to 10 times the adult value. The calculated dose to the fetal thyroid was also several times that of the infant.

These estimates of an increased relative radiologic dose to the thyroid glands of developing young following assimilation of radioactive iodine do not address, however, the possibility of a greater radiosensitivity of the immature thyroid (10). Hence, the relative risk of biologic damage to the thyroid of the young might be several-fold higher than the relative dose presented here, reflecting more biologic effectiveness per rem in the young. Therefore, the 10-fold increase in dose for the fetal gland for inhaled radioiodines and the 30-fold increase in dose for the thyroid of the infant from those which are ingested, relative to that calculated for adults, would appear to be appropriate lower limits.

In conclusion, dosimetric calculations for population exposures to the radioiodines from nuclear fuel cycle activities should address both ingestion and inhalation as routes of potential exposure. Such information would enable the potentially more sensitive members of the population to be defined and the variety of radioiodines to be considered.

\*Supported in part by the US Energy Research and Development Administration and the US Nuclear Regulatory Commission.

### REFERENCES

1. Aboul-Khair, S. A., Buchanan, T. J., Crooks, J., and Turnbull, A. C. Clin Sci 51:415, (1966).
2. Book, S. A., Garner, R. J., Soldat, J. K., and Bustad, L. K. Health Phys (in press).
3. Book, S. A. and Goldman, M. Health Phys 29:874, (1975).
4. International Commission on Radiological Protection, Report of Committee II on Permissible Dose for Internal Radiation, ICRP Publication No. 2, Pergamon Press, 233 p., (1959).
5. International Commission on Radiological Protection, Report of Committee IV on Evaluation of Radiation Doses to Body Tissues from Internal Contamination due to Occupational Exposure, ICRP Publication No. 10, Pergamon Press, Oxford, 94 p., (1968).
6. International Commission on Radiological Protection, Report of the Task Group on Reference Man, ICRP Publication No. 23, Pergamon Press, Oxford, 480 p., (1975).
7. Sikov, M. R. Radiat Res 38:449, (1969).
8. Soldat, J. K. Health Phys 30:61, (1976).
9. Wellman, H. N., Kereiakes, J. G., and Branson, B. M. Total- and Partial-body counting of children for radiopharmaceutical dosimetry data. In: Medical Radionuclides: Radiation Dose and Effects, Edited by Cloutier, R. J., Edwards, C. L., and Snyder, W. S., Oak Ridge, TN, US AEC, p. 133-156, (1970).

Table 1. Dose Estimation Parameters

Age	Thyroid Wt (g)	T <sub>1/2</sub> (days)	Milk Consumption/Day (liters)	Inhalation Rate (m <sup>3</sup> /min)
Adult (male)	20	100	0.3	0.02
(female)*	17	100	0.3	0.019
Infant (6 mo)	1.5	20	1.0	0.004
(1 yr)	2	20	0.58	0.0042
Child (5 yr)	5	50	0.49	0.0065
(10 yr)	10	50	0.48	0.013
(15 yr)	15	100	0.44	0.0165

\*Utilized for the calculation of fetal thyroidal doses.

Table 2. Doses to thyroid glands from one day's ingestion of milk containing 1  $\mu\text{Ci}$  of  $^{131}\text{I}$ /liter and from one minute's exposure to air containing 1  $\mu\text{Ci}$  of  $^{131}\text{I}$ ,  $^{132}\text{I}$  or  $^{133}\text{I}$  per  $\text{m}^3$ .

	Ingestion (rem/day)	Inhalation (mrem/min)		
	$^{131}\text{I}$	$^{131}\text{I}$	$^{132}\text{I}$	$^{133}\text{I}$
Adult	0.48	25	0.17	2.3
Fetus (13 wk)	0.04	2	0.1	1.0
(20 wk)	1.2	60	1.2	13.4
(32 wk)	3.3	160	1.8	22
Infant (6 mo)	15.7	50	0.6	6.1
(1 yr)	6.8	40	0.4	4.7
Child (5 yr)	2.4	20	0.2	1.9
(10 yr)	1.4	30	0.2	3.0
(15 yr)	0.9	25	0.2	2.5

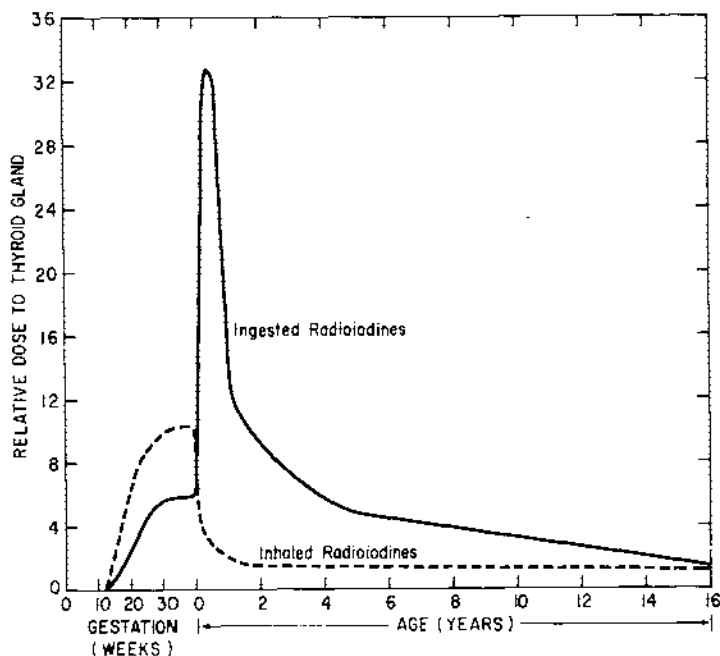

Fig. 1. Doses to thyroids of fetuses and children, relative to those of adults, from ingested or inhaled radioiodine.

## LIFETIME DOSE OF PERSONS WORKING IN RADIOGYNÆCOLOGICAL DEPARTMENTS

L. Bozóky

National Oncological Institute, H-1525 Budapest 114 P.O.Box 21.

and

T. Predmetszky

"Frédéric Joliot-Curie" National Research Institute for Radiobiology  
and Radichygiene, H-1775 Budapest-BudafoK 1.P.O.Box 101. Hungary

## 1. INTRODUCTION

Ever since 1936 when the National Oncological Institute opened its gates radiogynaecological treatments have been systematically carried on, meaning severe radiation loading for persons working in the field. As a result of the very favourable recovery, radium therapy continued in many institutions of Hungary further on, we decided the determination of lifetime dose values of persons who actually worked in this special field for 40 years by means of the high amount of radioprotection measuring data, available. Since, in the course of the past ten years, ICRP has, on several occasions significantly decreased the maximum permissible dose values and in this sense we developed ever newer, more efficient radioprotective equipments, the lifetime doses were determined by summing partial values, evaluated for each period of time. Apart from this, we examined how data of film-dosimeters carried on at cardiac regions, as well as integral dose values calculated on whole-body, demonstrate the ever better efficiency of our radioprotective equipments in the various periods.

## 2. PHASES OF THE DEVELOPMENT OF OUR RADIOPROTECTION

From the point of view of the radioprotective equipments development of the radium operating theatre, three phases can be distinguished as follows:

1) From 1936 to 1947, the radioprotective armamentarium of a gynaecological department consisted only of a wall-storage and a simple lead-shielded working table with forceps and pincers.

2) From 1947 to 1957, after the preparation of the patient a 6 cm thick, railed lead-shield was pulled in between the sitting physician and patient on one hand and a lead-wall with 12 cm thickness was built in front of the surgent's assistant on the other, from which radium tubes were lifted out only in the last moment (1).

3) From 1957 to 1976, there was built a 10 cm thick, rolling lead-shield between the assistant and patient, moreover, the lead-shielded working table was developed by a surmounted, even head protecting lead-shield with a double mirror-system, automatic washing apparatus, sterilizer and a railed, radio-protected delivery truck serving for the delivery of sterile tubes in the operating theatre. Finally, a special lead-shielded truck was constructed for radioprotected carrying of radium tubes back from the sick ward.

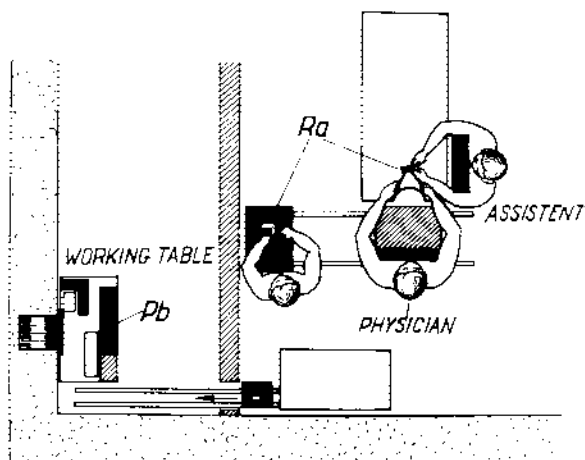

Figure 1. Lead-shield pullable in between the physician and the patient, assistant and the patient, Lead-well, radium delivery truck and radium working table

### 3. THE DETERMINATION OF LIFETIME AND INTEGRAL DOSES

The dose loading of workers performing duties in the fourth most severe radiation loading place of the gynaecological department was measured in the three periods, several times by film-dosimeters placed on various parts of the body.

#### 3.1 Dosimeter-data on cardiac region

Since 6-9 pcs of 10 mCi radium tubes were inserted a patient and the time of insertion alternated from 1,5 to 10 min. according to cases, we calculated the average values on 1 Ci radium and on an average insertion time.

	PERIOD			Lifetime dose	
	i.	ii.	iii.	1936-76	1957-97
Physician	7,5R/year	1 R/year	1 R/year	102 R	40 R
Surgeon's assist.	21 "	5 "	4 "	350 R	160 R
Assistant	31 "	28 "	0,6 "	600 R	25 R
Carrier of patients	8 "	8 "	8 "	300 R	300 R

TABLE 1 Average annual doses and lifetime doses in four most exposed working spheres

In Table 1 we demonstrate the R/year values referring to the three subsequent periods calculated on the personal dosimeters data on cardiac region and lifetime dose values determined with respect to the past 40 years. As for physicians, two in the first period and three in the second and third period, resp. effected insertion for 3 months in regular turns, thus values of the Table indicate the physicians. In the other three working spheres personal turns

were irregular, consequently values in the Table are calculated on the total, annual 100 Ci radium, disregarding the number of persons who received it. In the last column of the Table extrapolated values are figuring according to the data of the third period which, according to the improved radioprotective conditions are significantly lower than the data relating to the past 40 years figuring in the previous column. The only exception here is the hospital attendant whose case the dose cannot be lowered but by means of a personal change only. There are 50 persons altogether at the department working in 4 shifts. The distribution of 12 most exposed persons' annual dose-loading in the course of 8 years, that is between 1967 and 1974, is demonstrated in Table 2. From among 12 persons, there is a physician working for 40 years and 2 physicians working for 29 years at the same working sphere. Lifetime dose on these persons, as well as others working in other departments of the Institute for 40 years is indicated in Table 3.

mR/year	cases
0,25 - 0,5	35
0,5 - 1	22
1 - 2	21
2 - 3	10
3 - 4	4
4 - 5	4

TABLE 2 Average annual dose-distribution at 12 most loaded workers between 1967 and 1974

Profession	Department	Work-time	Lifetime dose
Physic.1.	Gynaecologic.	40 years	102 R
Physic.2.	"	29 "	36
Physic.3.	"	29 "	32
Surg.assist.	"	30 "	140
Physic.4.	Radiologic.	40 "	25
Physic.5.	"	40 "	38
Physicist 1.	Physical	40 "	80
Physicist 2.	"	40 "	30

TABLE 3 Lifetime doses at eight most oldest workers of the Institute

### 3.2 Comparison between cardiac region and integral doses

For the sake of efficiency establishment of recently developed radioprotective equipments we made some measuring during the working process of the same persons (inserting 1 Ci radium), either at the cardiac region or at further 10 points of the body for the determination of the integral dose. Measuring results and the integral dose values obtained under different working conditions in three periods are figuring in Table 4. Integral doses have been calculated partly according to the Haymeord-formula, partly on other methods.

	1936-46		1947-57		1958-76	
	mR/Ci	gR/Ci	mR/Ci	gR/Ci	mR/Ci	gR/Ci
Physician	100	7,800	10	2,800	10	2,600
Surgeon's assist.	150	14,000	35	6,800	30	6,800
Assistant	300	12,800	280	11,300	6	6,100
Carrier of pats.	80	11,600	80	11,000	80	11,000

TABLE 4 Doses relating to inserting of 1 Ci radium and integral doses in the three phases of the development of radioprotective equipments

On this manner (Fig.2) the effect of the lead-shield to be placed in front of the physicial can be determined either on the cardiac region or in the integral dose.

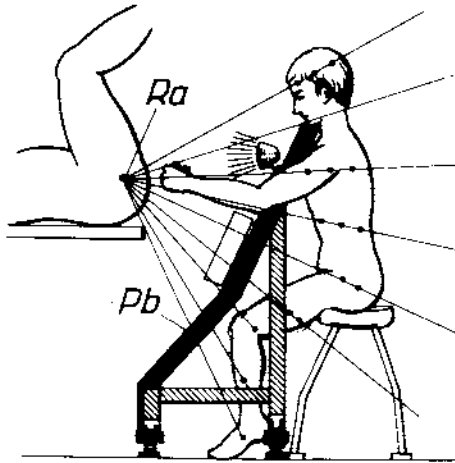

**Figure 2** Physical protecting lead-shield with projecting lines necessary for the calculation of integral doses

#### 4. CONCLUSIONS

4.1 It can be stated that the gynaecological radioprotection equipment fitted to Mutscheller-tolerance-dose valid 40 years ago can be developed further on, even meeting the present maximum permissible dose values and requirement. Equipments we developed are mounted in any national gynaecological radium department.

4.2 In order to lower the workers' radiation loading to a significantly less maximum permissible dose value, expressed by recent literature data as very desirable, it is advisable to effect a regular turn in most of the exposed working spheres.

4.3 It was established that a physician in the third period is exposed to ten-times less cardiac region dose than in the first period, nevertheless, his integral dose becomes only three-times lower. In case of the assistant the cardiac range dose becomes 50-times lower depending on the fact that her dosimeter and most part of her body get into the shadow of the lead-shield, however, her integral dose lowers to its half only, while, on the other hand the integral dose lowering at the surgeon's assistant is double under five-times cardiac region dose lowering.

4.4 The same dose, therefore, shown by a dosimeter belonging to the same person may involve integral doses of various orders of magnitude that possible significantly influence the biological damage. For this reason, we suggest that in some cases when personal dosimeter data approach the maximum permissible values, e.g. reach the half of it, the evaluable integral dose value, when concluding things to be done that is at the real estimation of the effective damage, should be taken into consideration. It is very probably that the idea of the integral dose is not the only proper one for the judgement of the biological damage, however, the information it renders is, by all means, more rich than that of given by the personal dosimeter. Their interdependence involves further, closer investigation.

A REVIEW OF THE PROBLEMS OF SAFETY CONTROL IN X-RAY  
DIFFRACTION AND SPECTROMETRY

G.S. Linsley  
National Radiological Protection Board  
Harwell, Didcot, Oxon, England

1. INTRODUCTION

The use of x-rays in diffraction and spectrometry is widely regarded as being one of the most potentially hazardous operations carried out in the laboratory. The reasons for this are clear; some aspects of work with the equipment bring the user into close proximity with narrow but intense x-ray beams such that brief exposures of a few seconds duration can cause serious burns. Fortunately, the burns tend to be localised to the hands and the low energy of the radiation usually limits the extent of the damage to the skin tissues.

The study of the accidents which have occurred in work with such equipment provides guidance on those aspects of the work where safety control needs most emphasis. Several surveys have been conducted and reported in the literature. They are summarised in Table 1 together with data extracted from the records of investigations conducted by the National Radiological Protection Board. These investigations were freely requested by the establishment in which the equipment was being used and it is probable that the Board has only been involved in a small fraction of the total number of such accidents occurring in research and factory establishments. However, this is a problem common to all surveys of incidents resulting from x-ray diffraction and spectrometry equipment. The localised nature of the biological damage which results from exposures of this type is often passed off as being due to another cause, such as a thermal burn, or is simply ignored. The film badge is of very limited use in identifying accidental personal exposures since the narrow x-ray beams encountered will only be detected if they impinge directly on the film.

	Lindell et al (1968)	Lubenau et al (1969)	Stern (1970)	Jenkins et al (1975)	NRPB data
Total number of incidents reported	21	17	22	36	18
Incidents due to human error { (1) (2)	8 (71%) 7	8 (71%) 4	16 (73%)	20 <sup>†</sup> (56%)	14 <sup>†</sup> (78%)
Incidents due to equipment failure	5 (24%)	5 (29%)	6 (27%)	9 <sup>†</sup> (25%)	2 <sup>†</sup> (11%)
Other causes (some unknown)	1			7	2

(1) Carelessness

(2) Inadequate instruction

<sup>†</sup> Some of the distinctions used here are not clear cut. The incident may be the result of a combination of human error and equipment inadequacy.

TABLE 1 Surveys of incidents in x-ray diffraction and spectrometry



For comparison purposes the NRPB incident data has been reported in the same way as the other surveys in the literature (Table 1). However the 14 incidents reported under "human error" can be further subdivided as:

Accidental exposures as a result of equipment having been modified (unknown to the user)	4
Inadequate instruction of user	1
Carelessness	7
Carelessness, partly due to inadequate safety devices	2

Despite the relatively small number of incidents included in each survey and the individual interpretations of the authors, the results are similar. Between a half and three quarters of the reported accidents appear to have their origins in human error, whether due to carelessness or to ignorance on the part of the user. Many of those attributed to carelessness were caused by persons inadvertently putting a hand or arm into a beam in the course of a camera alignment operation or as a result of forgetting that the x-ray set was energised or that a shutter was open. In these latter cases the exposures would have been less likely if better safety devices had been fitted, for example, clear warning signals to indicate the status of the x-ray tube and the shutters. However, some of the incidents investigated by NRPB suggest that there can be a danger in providing too many safety devices. In one incident, an experienced maintenance engineer was exposed to a primary x-ray beam because he placed overmuch reliance on the electrical interlocks in the system. Unknown to him, one of the interlock devices had been overridden with the result that a shutter was open when he thought it was closed. In many cases if a suitable radiation monitoring instrument had been close at hand accidental exposures would have been avoided.

## 2. EQUIPMENT

The designs of commercially available equipment for use in x-ray diffraction and spectrometry have improved considerably from the safety standpoint in the last twenty years. The majority of modern x-ray tube shields are fitted with safety shutters designed to prevent an x-ray beam from being emitted from the x-ray tube unless a camera is in position. The majority of incidents in Table 1 which have been associated with equipment failure have probably happened in work with old equipment fitted with few safety devices. Nevertheless, the standard of safety of many modern x-ray diffraction systems leaves much to be desired. Often it is left to the user to provide warning signals to indicate when x-rays are being generated and whether shutters are open or closed. Some manufacturers offer the x-ray warning light as an optional extra! The absence of clear warning signals has led to several accidental overexposures.

A desirable feature in x-ray diffraction equipment is for the x-ray beams to be completely enclosed during normal use to prevent the possibility of hand access. However, there are many commercially available cameras and diffractometers in which hand access to the x-ray beam during normal use is possible, in particular, the simple and much used Laue camera. Full implementation of the Health and Safety at Work etc. Act 1974 in the United Kingdom which places an obligation on manufacturers and their agents to ensure that their products are safe, will prevent the sale of such equipment. The engineering of local enclosures for some of the larger camera types, for example, four circle diffractometers and precession cameras, which will still allow the user sufficient access for his experiments, has usually been considered by the manufacturer and user to be too difficult and costly. The equipment must therefore be housed in a separate room and the radiological protection of other staff is achieved by restricting access to the room.

Recently, however, some completely enclosed four circle diffractometers have become commercially available. The enclosure is in the form of a counter-balanced hinged perspex cover which can be lifted to allow considerable freedom of access to the camera system.

### 3. TRAINING

The survey of incident causes indicates clearly that the majority of reported accidents have been due to mistakes or ignorance on the part of the user. It is unrealistic to think that accidents resulting from human error can be eliminated altogether. However, they can be made less likely by ensuring that all persons coming into contact with the equipment are aware of the potential hazards and are trained in safe working methods.

Technicians and research workers who are new to work with x-ray diffraction and spectrometry equipment should undergo training before being allowed to work on it by themselves. The course of training should include instruction on the hazards of ionising radiations and in particular those associated with x-ray diffraction and spectrometry equipment. Safe working methods with the equipment being used in the establishment should be discussed and each course participant should become familiar with the use of a radiation monitoring instrument and be aware of the importance of routine monitoring. Training courses of this sort are provided in most large research establishments in the United Kingdom. However, attendance at such courses is usually voluntary and a large proportion of new users never attend a training course. The approach taken by one of the Universities in the United Kingdom has much to commend it. Students are not allowed to work on systems which are not at all times fully enclosed unless they have undergone a course of training. A Certificate of Competence is issued to the experimenter on completing the course.

### 4. ADMINISTRATIVE CONTROL

Many accidental exposures of persons have occurred while maintenance is being carried out on equipment or firing sample or camera alignment in the presence of an x-ray beam. On these occasions safety interlocks and covers may have been removed and momentary carelessness on the part of the user can lead to an overexposure. The responsibility for safety in such situations is very much in the hands of the user himself.

The risks to which the experimenter or maintenance engineer is exposed can, nevertheless, be minimised if the procedure to be adopted in a particular alignment or maintenance operation is subject to the combined scrutiny of the safety adviser and the user or his supervisor. A scheme can be drawn up which incorporates the safest methods consistent with experimental practicability. For example, the safety adviser must be convinced by the user that the alignment operation requires the presence of x-rays and cannot be achieved by optical means. In many situations it is possible to devise enclosures with slits such that the alignment operation can be conducted without direct access to the x-ray beam. If an x-ray method has to be used the equipment should be operated at the lowest kilovoltage consistent with obtaining a satisfactory image or count rate, long handled tools should be used and a radiation monitor kept close at hand. The wearing of finger dosimeters should also be considered.

When such a method of work has been agreed between the user and the safety adviser it should be formalised in writing and should include the names of the persons authorised to carry out the operation.

The main objective in formalising the scheme is to impress upon the users that it is to be taken seriously. The written scheme is also valuable as a record and when it is posted near to the x-ray equipment it serves as a reminder of the procedures which should be followed.

## 5. CONCLUSION

While it is important that improvement in the safety of equipment continues the main emphasis should be on making the user aware of the hazard by adequate training and in minimising the opportunities for human error by appropriate administrative control over working methods.

## REFERENCES

- (1) JENKINS, R. and HAAS, D.J., X-ray Spectrometry, 4 (1975) 33
- (2) LINDELL, B., Health Physics, 15 (1968) 181
- (3) LUBENAU, J.O., DAVIS, J.S., McDONALD, D.J. and GERUSKEY, T.M., Health Physics, 16 (1969) 739
- (4) STERN, B.E., Health Physics, 20 (1971) 358

## TWO INVESTIGATIONS CONCERNING THE RELEASE OF TRITIUM

C. Bergman and E. Wesslén

National Institute of Radiation Protection  
Fack, S-104 01 STOCKHOLM SwedenA. TRITIUM LEAKAGE FROM  $^3\text{H}(\text{Sc})$  ELECTRON CAPTURE DETECTORS

## 1. INTRODUCTION

In 1974 Varian AB introduced a new type of EC-detector containing tritium on the Swedish market. Compared to the old type, the new detectors had tritium bound to scandium instead of to titanium, they contained 1000 mCi compared to 250 mCi and they were intended to be used at  $325^\circ\text{C}$  which is  $100^\circ\text{C}$  higher than the old type. The well-known fact that tritium release increases rapidly at elevated temperature (1, 2) and the lack of independent measurements of the release from  $^3\text{H}(\text{Sc})$  EC-detectors explained the necessity for this investigation.

Similar measurements were made on a  $^3\text{H}(\text{Sc})$  EC-detector containing 75 mCi tritium sold by Packard Instrument AB.

## 2. MEASUREMENTS

New EC-detectors were borrowed from Varian AB and Packard Instrument AB for measurements at the Institute and old detectors were measured at various laboratories. During all measurements the EC-detectors were mounted in gas-chromatographs and heated by their ordinary heating systems. This makes the actual detector foil temperature approximately  $25^\circ\text{C}$  below the indicated detector temperature. Pure nitrogen gas was used as carrier-gas through the detector with a flow of 30-50 ml/minute. The nitrogen gas passing the EC-detector was mixed with air - 3 litres/minute - and used as counting gas in a TRITON 1055B tritium monitor.

For the determination of the ratio between the tritium in the form of HT and HTO a cold-trap, cooled to  $-80^\circ\text{C}$ , was used to condense the HTO.

## 3. RESULTS

More than 95 % of the tritium released from the  $^3\text{H}(\text{Sc})$  EC-detector was in the form of HTO since it was condensed in the cold-trap when this was inserted into the system.

In Fig. 1 the release of tritium from three Varian EC-detectors as a function of temperature is illustrated. The detectors each contained 1000 mCi of tritium and they were heated at a rate of  $2^\circ\text{C}$  per minute. The three curves represent the following detectors.

- Curve I: A new detector that had not previously been heated.
- Curve II: A detector used at  $300^\circ\text{C}$  for one week, during which time it was cleaned three times, and then stored at room temperature for more than one year before this measurement.
- Curve III: A new detector which, three days before the measurement, had been heated to  $350^\circ\text{C}$  for one hour.

Points A and B show the release from two detectors which had been used at 275°C for 3 months and at 300°C for 10 months respectively.

Curve I Fig. 2 shows the leakage from a new Packard detector which had not been heated before and curve II shows the same detector measured two days later. In the meantime the detector had been kept at 325°C for 2 hours. The detector was heated at the same rate as above.

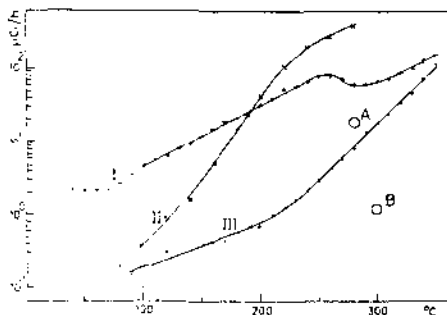

Fig. 1. Release of tritium from three Varian  $^3\text{H}(\text{Sc})$  EC-detectors. I, new detector; II, stored one year after heating; III, shortly after previous heating. See text for further details.

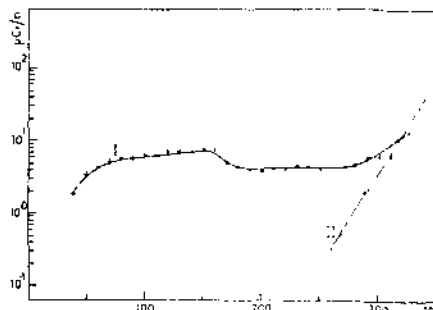

Fig. 2. Release of tritium from a Packard  $^3\text{H}(\text{Sc})$  EC-detector. I, new detector; II, shortly after previous heating. See text for further details.

#### 4. COMMENTS

From the difference between the tritium release curve for a new detector (or a detector stored for a long time) and the curve from a detector that has been used at high temperature shortly before the measurement it is evident that the tritium is in two different forms on the foil. One form - tritium dissolved in the scandium lattice - permits the tritium to escape easily from the foil even at moderately increased temperature, while the other form - scandium tritide - is more stable with regard to increased temperature.

Even at room temperature the dissociation of tritide into tritium which is dissolved in the scandium is notable. This is clearly demonstrated by curve II in Fig. 1 which shows the effect of 1 year at room temperature.

The release of tritium from the Varian and Packard  $^3\text{H}(\text{Sc})$  EC-detectors corresponds roughly to the different activities of the detectors. At 325°C the leakage from the Varian detector is 0.1 % per day and for the Packard detector 0.6 % per day.

- (1) HOWLEY, J.R., ROBBINS, C., BROWN, J. M., Jr. "Health Physics Considerations in the use of Radioactive Foils for Gas Chromatography Detectors", *Health Phys.* **18** (1970) 76
- (2) KARAMIAN, N.A. "Ventilation of Electron Capture Detectors", *Health Phys.* **23** (1972) 257

## B. RADIATION PROTECTION ASPECTS OF WORK WITH TRITIUM IN LUMINOUS FILM

### 1. INTRODUCTION

This paper deals with the handling of tritium in the form of small discs of luminous film. The investigation was initiated when a Swedish factory got a large order for dark-sights for Swedish army weapons. The aim of our work was to see how much the personnel exposure could be reduced by readily achievable means of protection and to estimate the relative importance of the different intake routes.

The luminous film used was obtained from W. Maier Komm. Ges., Germany. It contained pigment quality HA 180 with a specific activity of 160 mCi per gram pigment. It was bought in the form of punched discs of two different sizes, one with a diameter of 3.8 mm containing 0.9 mCi tritium and the other 2.3 mm diameter and 0.35 mCi tritium.

The tritium work was done by one man with a work capacity of 100 dark-sights per hour which meant the handling of 160 mCi tritium.

### 2. MEASUREMENTS

For high tritium concentrations the airborne tritium was measured with a commercial tritium monitor (TRITON 10558). For measuring lower tritium concentrations the air was passed through silica gel from which the absorbed water, which contained the tritium in the form of HTO, was subsequently distilled and measured in a Beckman Betamate II liquid scintillation spectrometer.

Urine from the employee was measured with no previous distillation in the same spectrometer. For calibration of the spectrometer the internal standard method was used.

### 3. RESULTS

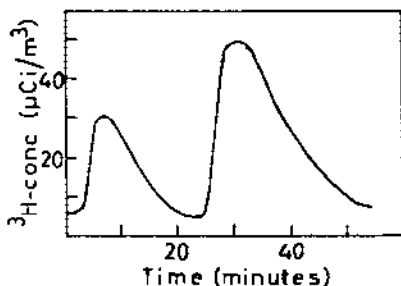

Fig. 1. Tritium concentration in the air during one hour of work in a poorly ventilated working area. The rapid increase in tritium concentration occurs when luminous discs for immediate use are poured out from a closed box containing several thousand.

Fig. 1 presents the results from the first measurements which were made shortly after the start of the work with tritium. The tritium concentration in the urine was found to be 6  $\mu\text{Ci/l}$ .

Installation of a better ventilation hood mounted directly above the working area resulted in a mean tritium concentration of 0.5-1  $\mu\text{Ci/m}^3$  in the breathing air. Measurement with the TRITON showed no value exceeding 2  $\mu\text{Ci/m}^3$ . In the area for the hands the concentration varied between 3 and 150  $\mu\text{Ci/m}^3$  with a mean value of approximately 35  $\mu\text{Ci/m}^3$ .

The tritium intake, as represented by the tritium concentration in the urine, is illustrated in Fig. 2 together with the work intensity.

All urine samples were taken on Monday mornings before the tritium work was begun. Although the work intensity was higher towards the end of the

first work period the tritium concentration showed a decreasing trend. This is assumed to be because of increased care and skill of the employee.

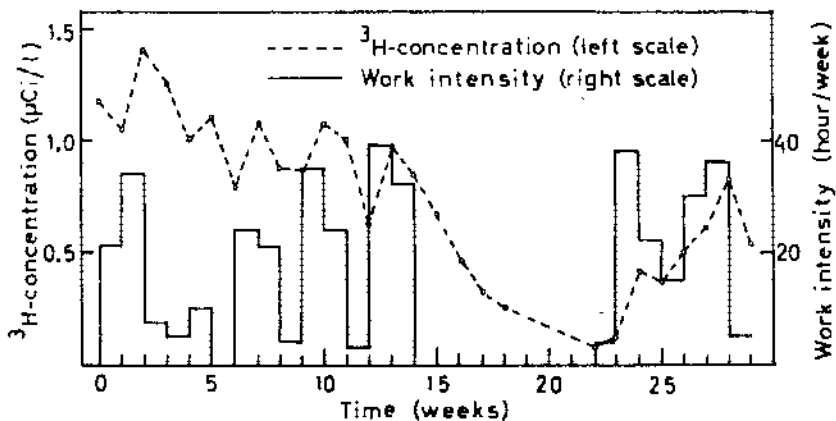

Fig. 2. Tritium concentration in urine and work intensity during the same time. For the first 14 weeks the work was done with bare hands and for the 7 last weeks thin plastic gloves were used. Note the different scales for the two graphs.

In order to estimate the intake through the lungs in comparison to the intake through the skin the employee used thin plastic gloves when the work was recommenced after a two month break. Unfortunately, the man ran out of gloves and worked for two days with bare hands during week 26 and during week 27 he worked for a short time with another type of dark-sights that contained more tritium.

#### 4. CONCLUSIONS

The easiest way to reduce the tritium intake from work with luminous material is to arrange a good ventilation of the working area. In this way the reduction in the tritium intake corresponded to a reduction in the urine activity from 6 to 1 µCi/l. By using gloves to prevent the intake through the skin a further reduction to 0.5 µCi/l was achieved. 50 % of the intake was found to be through the skin and this is in good agreement with the results of Billaudelle and Kaltenhäuser (1).

An average handling of 3.4 Ci tritium per week in the form of luminous film resulted in an average urine activity of 0.5 µCi/l. Integrated over a long period of time this gives a dose of 0.3 mrem/Ci. This can be compared to the values given in Table 2 in Ref. 2 where the value from Moghissi et al. is 19.1 mrem/Ci and those from Krejci vary between 1.3 and 21.7 mrem/Ci. The lower dose found in our measurements reflects the fact that there is lower tritium leakage from luminous film than from luminous paint with the same activity.

- (1) BILLAUDELLE, H., KALTENHÄUSER, A., Penetration of Tritium in the Skin Resulting from the Utilization of Radioluminescent Paints, Nucl. Sci. Abstr. 30:2 (1974) 381 (Abstract No 3693).
- (2) MOGHISSI, A.A., CARTER, H.W., Public Health Implications of Radioluminescent Material, DHEW Publication (FDA) 76-8001, DHEW, Maryland, USA.

## HAZARDS ANALYSIS OF LASER FUSION TARGETS CONTAINING TRITIUM\*\*

T. Jordan Powell  
Lawrence Livermore Laboratory  
P. O. Box 808  
Livermore, California 94550

## 1. INTRODUCTION

For the past several years there has been an intense effort at the Lawrence Livermore Laboratory and elsewhere to prove the concept of laser fusion. At Livermore, this effort has been twofold - the development of high-powered, multiple-beam lasers and the construction of tiny tritium-deuterium targets for these lasers.

Among the more advanced laser concepts is the SHIVA laser system which is expected to be operational in July 1977, with an estimated energy output of over 10 kilojoules per pulse delivered in less than one nanosecond. Like Shiva, the multi-armed Hindu god of destruction and reproduction, this system consists of 20 laser beams directed onto a single target in such a way as to cause a spherically symmetric implosion of the target and, thus, induce fusion in the tritium-deuterium fuel.

## 2. LASER FUSION TARGET

The typical laser fusion target consists of a hollow glass sphere, called a microballoon, with a diameter in the range of 20 to 150 micrometres and a wall thickness of one to several micrometres. In order to load the fusion fuel into the microballoon, it is heated to a temperature of several hundred degrees Celsius in a high pressure tritium-deuterium atmosphere. Under these conditions, the fuel will diffuse through the walls of the microballoon. When the temperature is reduced and the pressure removed, the tritium-deuterium fuel will remain trapped within the microballoon. A typical microballoon will contain up to several hundred microcuries of tritium after filling.

## 3. HAZARDS ANALYSIS

Hazards analysis indicates that intact microballoons present only a negligible hazard. They are not respirable and, even if ingested, only a small fraction of the tritium beta energy might penetrate through the wall of the microballoon. If a microballoon is broken, a small hazard will exist for a short time because of the release of the contained tritium. However, even this hazard is very small - 100  $\mu$ Ci of tritium inhaled or ingested as water will deliver a dose of about 10 mrad, and there is at most a few hundred microcuries of tritium in a microballoon as hydrogen gas.

In order to complete the hazards analysis, it is necessary to determine the hazard associated with the glass fragments from a broken microballoon. To do this, the following questions need to be answered:

\*Work performed under the auspices of the U.S. Energy Research and Development Administration, under contract No. W-7405-Eng-48.



- a. Are the glass fragments from a broken microballoon of the respirable size that are retained deep in the pulmonary lung?
- b. Do the glass fragments of a broken microballoon contain tritium?
- c. Finally, if the fragments are respirable and do contain tritium, how well is it contained? That is, what is the biological half-life in the lung of tritium contained in glass?

In order to demonstrate that the glass fragments from a broken microballoon are respirable, a number of microballoons were intentionally broken on a microscope slide. The resulting fragments ranged in size from nearly complete microballoons to fragments only a few tenths of a micrometre in their maximum dimension. The relative abundance of the small particles that would be retained deep in the pulmonary lung depends somewhat on how the microballoon is crushed. Thus, the particle size distribution cannot be established except by survey of a work environment into which microballoons have been released and in which they have been broken.

The fact that the glass fragments from a broken microballoon contain tritium is easy to demonstrate. A number of tritium-deuterium loaded microballoons were crushed to release the tritium contained within the microballoons. The remaining glass fragments contained tritium even after repeated washing and heating to several hundred degrees Celsius. This tritium was released only by dissolution of the glass in hydrofluoric acid or by melting. Thus, the tritium appears to be bound into the chemical structure of the glass. The concentration of tritium in the glass fragments was in the range of 1/2 to 1 Ci of tritium per gram of glass. Because of the small quantity of glass in a microballoon, however, the total tritium bound into the glass is on the order of 1  $\mu$ Ci per microballoon.

The experiments showing that the tritium was released from the glass only by dissolution or melting suggest that the tritium will follow the glass once it is deposited in the lung. To demonstrate that this is the case, an experiment was conducted to determine the rate at which tritium, in glass fragments from broken microballoons, was released into a simulated lung fluid (normal saline). The release rate for the glass used in these experiments corresponded to a biological half-life of over 200 days. For other glasses, the release rate might be somewhat slower or faster depending on the solubility of the glass and how it binds tritium.

With these data, it seems appropriate to treat the glass fragments from broken microballoons as particles that will behave as an ICRP Class Y aerosol once deposited in the lung, that is, as dissolving slowly in the pulmonary lung or being phagocytized to the pulmonary lymph nodes. With this assumption, one can calculate the radiation dose that could result from inhalation of tritiated glass fragments from microballoons used as targets in laser fusion experiments. The results of these calculations are shown in Table 1.

Form	Amount	Radiation Dose	Organ
HTO	100 $\mu$ Ci	0.01 rad	Whole Body
Tritiated glass	100 $\mu$ Ci deposited in pulmonary lung	20 rad	Pulmonary lung
		45 rad	Pulmonary lymph nodes

NOTE: Calculation of the dose from tritiated glass is based on the ICRP lung model, Class Y aerosol. Self-absorption of beta energy in the glass fragments has been ignored.

Table 1. Radiation Doses From Inhaled Tritium

While a toxicity ratio (per  $\mu$ Ci deposited in the lung) of several thousand is indicated for tritium in glass versus tritium as HTO, the difference in hazard between the two is not nearly so great. This is because of the ability of the lung to reject deposition of particulate matter and the fact that glass is not absorbed through the skin as is water. The relative hazard is illustrated in Table 2 in terms of the maximum permissible concentration (MPC) in air of tritium as HTO and tritium in glass.

Form	MPC (in air)	Critical Organ
HTO	$2.9 \times 10^{-6}$ $\mu$ Ci/cc	Body tissue
Tritiated glass	$4.5 \times 10^{-8}$ $\mu$ Ci/cc	Pulmonary lung

Table 2. Maximum Permissible Concentration of Tritium in Air

In this table it was assumed that the tritiated glass fragment behaved as a 1  $\mu$  Class Y aerosol (ICRP) and a quality factor (QF) of 1 was used for tritium in both forms. On this basis, the relative hazards are such that tritiated glass appears to be only about 70 times the hazard of tritium as HTO.

#### 4. SUMMARY

The Livermore laser fusion target, as described in this paper, presents a unique problem in radiation dosimetry in which tritium is encountered in a form that may be more hazardous than tritium in its most common form (water).

The hazards of handling the intact microballoon or the gas from a broken microballoon are negligible, unless very large quantities of tritium are involved. The glass fragments of a broken microballoon contain tritium in a form that is much more toxic than tritiated water - about 2000X when compared on the basis of deposition in the lung. The relative hazard of tritiated glass is about 70X that of tritium in water. Because of this greater hazard, the laser fusion target should be handled with greater care than is tritium in its more common forms. Tritium in glass has a hazard comparable to that of Pu-241, Pa-233 or Mo-99 in airborne insoluble forms.

Care in handling, cleanliness in the laboratory, and isolation of the material are required in handling laser fusion targets as those released to the laboratory environment will be very difficult to detect. Once deposited in the lungs, quantities of tritiated glass that could deliver a substantial radiation dose will be impossible to detect.

COMPARATIVE RESPONSES OF  
THERMOLUMINESCENT DOSIMETERS IN  
ENVIRONMENTAL MONITORING SITUATIONS

George L. Toombs  
Ray D. Paris

Oregon State Health Division  
1400 S.W. 5th Avenue  
Portland, Oregon 97201 USA

## 1. INTRODUCTION

Ambient radiation measurements are of importance in defining natural background levels and for determining the extent and significance of additional radioactivity introduced into the environment from man-made sources. Various types of radiation detection equipment and dosimeters have been applied to the evaluation of ambient radiation levels. Recently, Thermoluminescent Dosimeters (TLD's) using various phosphors have been effectively utilized for these types of measurements (1). Although considerable information is available in the literature on Thermoluminescent Dosimetry, data relating to actual response characteristics of the various phosphors, specifically to terrestrial and cosmic radiation, is not readily available.

## 2. METHODOLOGY

The evaluation of the response characteristics and reliability of TLD's for environmental measurements was performed by simultaneously exposing applicable phosphors to cosmic and various levels of terrestrial and man-made radiation. The locations were selected to cover a variety of situations, which included urban environments, the environs of a nuclear power installation, and a high mountain lake essentially free from terrestrial and man-made radioactivity. The same dosimeters used were included in the Second International Cross Check conducted by the Health Safety Laboratory (HASL) (2) to confirm the validity of the results obtained through this comparative study. Measurements were also undertaken with a Reuter-Stokes Pressurized Ionization Chamber and by using a 7.6 cm by 7.6 cm Sodium Iodide scintillation detector coupled to a gamma spectrometer for comparative purposes (3).

The applicable phosphors used in this comparative study were  $\text{CaF}_2:\text{Dy}$ ,  $\text{CaF}_2:\text{Mn}$  and  $\text{LiF-700}$ ; specifically  $\text{CaF}_2:\text{Dy}$  and  $\text{LiF-700}$  (3.2 x 3.2 x 0.9 mm) chips and  $\text{CaF}_2:\text{Dy}$  and  $\text{CaF}_2:\text{Mn}$  bulb assemblies manufactured by the Harshaw Chemical Company. Shielding consisting of a 0.9 mm copper capsule providing an effective lower energy cut off at 40 KeV was used to normalize the lower energy response of the  $\text{CaF}_2:\text{Dy}$  chips, figure 1. The  $\text{CaF}_2:\text{Dy}$  and  $\text{CaF}_2:\text{Mn}$  bulb assemblies use an outer tantalum shield and single phosphor chip and heating element encapsulated in glass, in figure 2. The more linear response characteristics of  $\text{LiF-700}$  chips allowed encapsulation in unshielded plastic holders. A standard one meter distance was used to obtain the comparative response data in the terrestrial environment. The dosimeters themselves were contained in the arms of a plastic pipe stand as shown in figure 4.

Calibrations of the dosimeter and radiation counting equipment was conducted under controlled conditions similar to the placement and corresponding to exposure levels received in the environment. A 1.0 mg radium source certified by the U.S. National Bureau of Standards was used for this purpose.

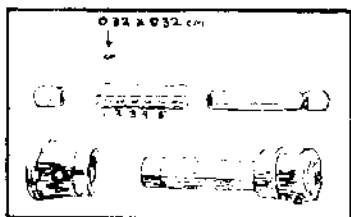

Figure 1 CHIP ASSEMBLY

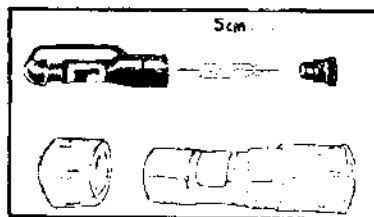

Figure 2 BULB ASSEMBLY

Harshaw 2000 and 2000P systems were used for the processing of the chips and bulbs. These systems consist of a thermoluminescent detector coupled to an automatic integrating picoammeter. Prior to use, all chips were segregated and grouped according to their response characteristics. The five chip per dosimeter capsule initial groupings were maintained throughout the study for each location. Annealing of the chips and bulb assemblies required prior to all exposures followed the Harshaw recommendations (4).

## 2. OBSERVATIONS

This comparative response study confirmed the TLD phosphor  $\text{CaF}_2:\text{Dy}$  as being the most sensitive to the environmental radiation spectra as stated in the literature (1). This material was observed to be ten times more sensitive than  $\text{CaF}_2:\text{Mn}$  and thirty times more sensitive than  $\text{LiF-700}$  phosphors. This high sensitivity is of importance in obtaining statistically significant data using exposure periods as short as thirty days. The data among the various phosphors exposed to various environmental situations as presented in Table 1 showed excellent agreement and internal precision. The long term environmental radiation data and exposures derived through the International Cross Check Study determined by using  $\text{LiF-700}$  phosphors were approximately 15% lower when compared to other TLD materials used. Note Table 3.

The use of  $\text{CaF}_2:\text{Dy}$  and  $\text{CaF}_2:\text{Mn}$  phosphors was successfully applied to the measurement of cosmic ray intensities in an environment essentially free of terrestrial and man-made activity, the center of a large lake at an elevation of 968 meters as shown in figure 3. The dose rate determined at the surface using  $\text{CaF}_2:\text{Dy}$  bulb and chip dosimeters was 0.09 mR/day while  $\text{CaF}_2:\text{Mn}$  bulbs indicated a dose rate of 0.08 mR/day. These values compare favorably with the exposure rate value for absolute cosmic ray intensities of 0.11 mR/day at this elevation for latitude North 50 degrees as published by Lowder and Beck (5).

Using the same types of TLD dosimeters, sealed in plastic pipe, additional underwater measurements at 20 meter increments extending to the bottom of this lake were undertaken to determine the phosphor responses to a harder cosmic spectra. The decrease in the exposure rates observed with increasing depth is presented in graphical form in figure 5 and corresponds to the attenuation of cosmic rays in water as detailed by Rossi (6). The dose rates on the bottom, however, were higher resulting from the natural and fallout origin radioactivity contained in the sediments. The intercomparison of the  $\text{CaF}_2:\text{Dy}$  chip and bulb dosimeters over extended periods of six months underwater showed the same overall trends. The chip dosimeters were approximately 20% more sensitive to the cosmic spectrum than the equivalent phosphor bulb assemblies as displayed in figure 6. The exposure rates determined at appropriate sites using a pressurized ionization chamber and gamma spectrometer compared favorably with quarterly data accumulated using TLD dosimeters. This information presented in table 2 showed similar trends among sampling locations.

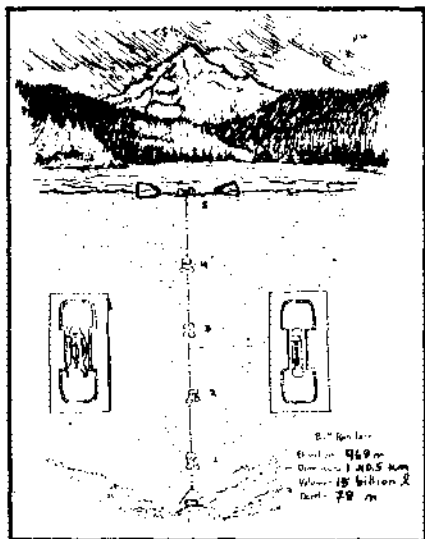

Fig. 3 HIGH MOUNTAIN LAKE

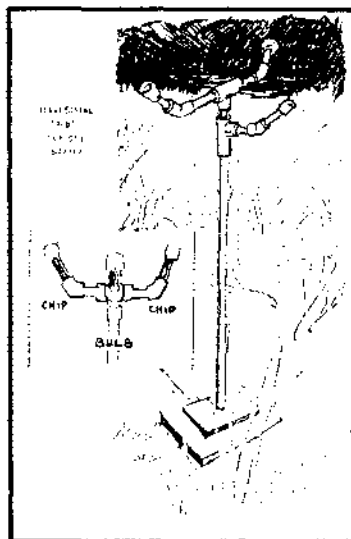

Fig. 4 TLD SUPPORT STAND

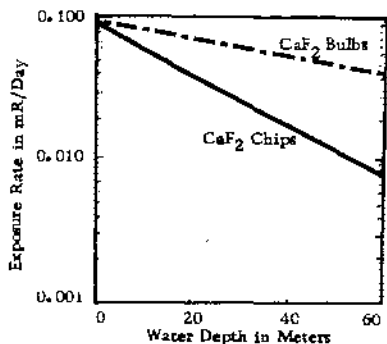

Figure 5 Cosmic Ray Attenuation in Water

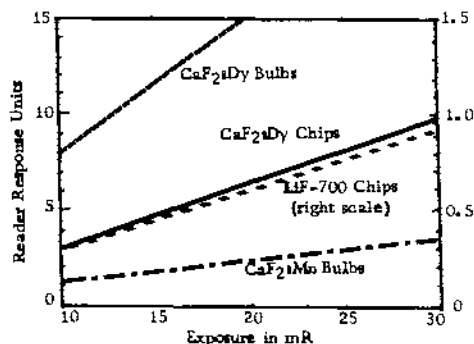

Figure 6 Dosimeter Sensitivities

#### 4. CONCLUSION

Thermoluminescent Dosimetry can be effectively used to monitor environmental exposure rates. Using applicable phosphors and procedures it was concluded that variations of less than 10 mR/year from established ambient levels can be detected with statistical confidence when the normal seasonal variations have been determined. Of the dosimeters evaluated the preferred choice for this purpose due to their high sensitivity, was CaF<sub>2</sub>:Dy chips although their handling, shielding and processing involved complex procedures. The CaF<sub>2</sub>:Dy bulb dosimeters were comparable in response to these chips for this type of monitoring. However, their easier handling and processing procedures are somewhat compromised by the larger capital investment in the dosimeters themselves.

Ambient radiation measurements using gamma spectrometers or pressurized ionization chambers were observed to be comparable with accumulated exposure rate data obtained using TLD dosimetry when appropriate calibration procedures are utilized. Additional ambient measurements of this type are considered to be useful in confirming the validity of the TLD data being accumulated over extended periods.

Table 1: Comparative Responses of TLD's in Various Environmental Monitoring Situations				
Results Expressed in mR/Day				
Environmental Situation	<sup>LiF</sup> -100 Chips	<sup>CaF<sub>2</sub></sup> :Dy Chips	<sup>CaF<sub>2</sub></sup> :Dy Bulbs	<sup>CaF<sub>2</sub></sup> :Mn Bulbs
Nuclear Facility	-	0.16 ± 0.01	0.17 ± 0.01	0.15 ± 0.01
	-	0.16 ± 0.01	0.18 ± 0.01	0.15 ± 0.01
	-	0.14 ± 0.01	0.17 ± 0.01	0.15 ± 0.01
	-	0.18 ± 0.01	0.17 ± 0.01	0.16 ± 0.01
High Mountain Lake (4 Depths 20m increments)	-	0.09 ± 0.003	0.09 ± 0.003	0.08 ± 0.003
	-	0.03 ± 0.001	0.03 ± 0.002	0.06 ± 0.002
	-	0.02 ± 0.001	0.06 ± 0.002	0.04 ± 0.001
	-	0.01 ± 0.001	0.05 ± 0.002	0.04 ± 0.001
Urban Environment	0.17 ± 0.01	0.20 ± 0.01	-	-
	0.16 ± 0.01	0.18 ± 0.01	-	-

Table 2: Comparative Responses of TLD's to Other Radiation Detection Equipment			
Results Expressed in mR/Day			
Location	Type of Detector		
	<sup>CaF<sub>2</sub></sup> :Dy Chips	7.6cm x 7.6cm NaI(Tl) Crystal	Reuter-Stokes Pressurized Ion Chamber
1	0.21	0.22	0.19
2	0.17	0.14	0.16
3	0.19	0.18	0.18
4	0.19	0.15	0.17
5	0.10	0.07	0.10
6	0.20	0.16	0.18
7	0.21	0.19	0.18
8	0.18	0.14	0.17

Table 3: Comparative Responses of TLD's in International Cross Check				
Results Expressed in Total mR				
	<sup>CaF<sub>2</sub></sup> :Dy Chips	<sup>CaF<sub>2</sub></sup> :Dy Bulbs	<sup>LiF</sup> -700 Chips	Mean of All Participants
Field Exposure	15.0 ± 0.9	14.8 ± 1.5	11.4 ± 0.6	16.4 ± 3.8
Lab Exposure	17.8 ± 0.9	16.7 ± 1.6	14.3 ± 1.0	18.0 ± 3.8

#### References

- (1) Denham, D.H., Kathren R.L., Corley J.P., A <sup>CaF<sub>2</sub></sup>:Dy Thermoluminescent Dosimeter for Environmental Monitoring, Battelle Northwest Laboratory Report #SA-4191, (1972).
- (2) Burke, G.P., Gesell, T.F., Becker, K., Second International Intercomparison of Environmental Dosimeters Under Field and Laboratory Conditions, ERDA, Health and Safety Laboratory, New York, N.Y. 10014, (1976).
- (3) State of Oregon, Trojan Preoperational Study, Oregon State Health Division, Portland, Oregon 97201, (1975).
- (4) Harshaw Chemical Co: TLD Materials & Systems; TLD Materials, Summary, Harshaw Division of Kewanee Oil Co.; Crystal and Electronic Products Department, 6801 Cochran Road, Solon, Ohio 44139.
- (5) Lowder, W.M. and Beck, H.L., Cosmic-Ray Ionization in the Lower Atmosphere, J. Geophys. Res., 71: pp. 4661 - 4668, (1966).
- (6) Rossi, Bruno B., Cosmic Rays, McGraw Hill Book Company, New York, pp. 36-42 (1964).

RECENT ADVANCES IN RADIATION MONITORING SYSTEMS FOR  
NUCLEAR POWER STATIONS

William S. Johnson, Sr.  
Eberline Instrument Corporation  
Post Office Box 2108  
Santa Fe, New Mexico 87501  
U.S.A.

1. INTRODUCTION

Present projections indicate that by 1990 a minimum of 600 nuclear power plants will be in operation in over 40 different countries. As a result, the health physics' profession is confronted with a massive responsibility to control the radiological consequences of these operations. Regulations have been adopted or are being considered by the various governments to guide the health physicist. It is apparent that the necessary radiological measurements will become increasingly complex, require improved sensitivity and accuracy, increase in frequency, and demand more attention from the health physics staff. There must be an expanded scope assigned to health physics instrumentation in order that available personnel will be able to cope with these new responsibilities. The discussion at this poster session will describe the integration of available instrumentation into a sophisticated system which will fulfill this new role in a cost-effective fashion.

2. HEALTH PHYSICS REQUIREMENTS

Based on the actual regulations and anticipating current attitudes of regulatory bodies in the United States, it is possible to summarize in general terms the health physics requirements to receive major emphasis over the next decade. Without a doubt one of these requirements will be the collection and documentation of data with more sensitive techniques and with improved error terms.

A second requirement will be the periodic determination of isotopic content of the various radioactive effluents, streams and processes which lead to personnel exposures. These data combined with the measurement of concentration, occupancy factors, internal retention patterns, significant environmental pathways and meteorological parameters will be necessary to provide estimates of dose. In the final analysis it will be these dosage calculations which control regulatory compliance rather than any of the individual elements in the equations.

All operations will be conducted in conformance with the philosophy of maintaining personal dosage history as-low-as-reasonably-achievable (ALARA). In the U.S. ALARA has been quantified in terms of its allowable environmental impact from light water reactors. However, there are many improvements to be realized in the application of ALARA to the occupational environment. A comprehensive basis for achieving ALARA will be a natural evolution from the evaluation of the data generated by fulfilling the two requirements above.

Obviously the health physicist must be given the tools in the form of authority, personnel and equipment to discharge his responsibilities. It should be evident that one of these essential tools will be the management and reporting of data in an intelligent manner readily assimilated into the decision-making process.



### 3. HEALTH PHYSICS INSTRUMENTATION REQUIREMENTS

Having established this background of operational and regulatory considerations impacting on the health physicist in a nuclear power plant, it is necessary that his supporting instrumentation be designed within the same parameters. The first recommendation is that a systems approach be adopted. Each source of data should be evaluated not as an isolated bit of information but rather in terms of its importance to overall operational significance. The author prefers to start with the concept of a Health Physics Operations Center controlling the flow and evaluation of data into and out of the Center. This concept is based on the utilization of microcomputer technology as the most cost-effective technique to meet reliably the health physics requirements of an expanding nuclear power economy.

Microcomputers or microprocessors are available in varying degrees of capacity and intelligence -- often classified from "dumb" to "smart". Fortunately most radiation measurements already exist in the digital mode so as to be compatible with the data collection, manipulation and storage features of a microprocessor. Digital counting is inherently more sensitive and statistically accurate, both necessary ingredients in future systems. A data base may be maintained at the individual detector as well as transmitted conveniently to the Main Control Room and/or Health Physics Operations Center. High resolution gamma spectrometry and other laboratory analyses may be interconnected to provide for the routine updating of isotopic content from collected samples. At these information centers there will be a merging of peripheral data, e.g., meteorology, in order that higher level dosage calculations may be computed. The historical file of personnel dose can also be kept current and available for immediate recall.

Probably the most convenient form of data presentation will be on a CRT terminal, again with its own microprocessor intelligence. These presentations may be tabular, graphic or multi-color graphic. Historical information should be retained in a format identical to reporting requirements in order to facilitate report preparation essentially instantaneously and at the prescribed frequency. It is the conviction of instrument designers that system limitations are only the imagination of the health physicist and not in his demands on hardware/software.

Other features to be retained in system development are flexibility and expandability. Significantly, about 80% of the personnel radiation dose from the power reactor program is received during plant shutdown. This fact implies a physical redistribution of radiation monitors between operational and non-operational periods consistent with the shift of radiological problems within the areas of a reactor facility. It is feasible to incorporate these features into a microprocessor-based system without significant cost because of the capacity and distribution built-in to interconnecting cables.

As one envisions the advantages of a fully computer-based system it is only natural to apply these advantages to the evaluation of radiological conditions caused by a variety of emergency situations. At the present time it is questionable whether this application will be permitted under all conditions. The testing of microcomputers throughout the entire cycle of radiation, aging and seismic environments has not been completed in order to qualify the entire system during the post-LOCA. This is considered to be a temporary situation which will be corrected as time and effort are devoted to a solution. In the interim less sophisticated techniques, previously tested and qualified, are available for those few radiation monitoring channels critical to a LOCA response.

#### 4. SYSTEM COSTS

There is a general rule for estimating purposes in the United States that installation costs of an analog radiation monitoring system equal the cost of the hardware. Most of this cost of installation is associated with the engineering, procurement, routing, isolation, interconnection and checkout of system cabling. Since it does represent a significant cost factor, reduction in cable requirements offers a fruitful area for cost savings. Digital, microprocessor-based systems are interconnected in a drop-loop, i.e., a single loop of cable from the Main Control Room to the monitoring stations and terminating at the most distant detector. This loop may be duplicated for redundancy and isolation. An analog system requires individual cabling between the Main Control Room and each monitoring station. Ideally, a drop-loop has the capacity for 192 channels but to preserve system flexibility and expandability perhaps only 50% are committed in a given design configuration. To add a monitoring station(s) or to re-configure existing stations it is only necessary to tie into the drop-loop, and not to re-wire between the station and the Main Control Room. Costs are reduced between 75% and 85% when compared with the cabling requirements of an analog system. However, the hardware/software costs of a microprocessor-based system exceed similar analog hardware costs so that total installed system cost savings amount to approximately 25% in favor of microprocessor-based systems.

Because data gathering, management and reporting are automatically processed, personnel devoted to these functions are either eliminated or assigned to other health physics' duties. Estimates vary as to the magnitude of this workload but it is on the order of a savings of two man-years per year per nuclear power plant.

It is more difficult to quantify the importance of the improved operator interface with the available data in an intelligent format. The ability to make a proper decision without undue delay is certainly enhanced. If this decision avoids a single shutdown unnecessarily or damage to expensive equipment, it will return system cost.

#### 5. CONCLUSION

Faced with extraordinary growth in nuclear power, the health physicist is being confronted with expanded responsibilities to control these radiological consequences. It represents, however, an opportunity for the profession to discharge its responsibilities in a manner which will reflect favorably on the environmental and public acceptance of nuclear power. A Health Physics Operations Center, fed by the data generated from a microprocessor-based radiation monitoring system, is recommended as a vital contributor to this objective while realizing significant savings in costs and personnel.

## THE NEW AUSTRIAN DOSIMETRY STANDARD LABORATORY

K.E. Duftschmid  
 Austrian Atomic Energy Research Organization Ltd.  
 Institute for Health Physics  
 Research Center Seibersdorf, Austria

## 1. INTRODUCTION

Due to the enormous increase in the medical and industrial use of ionizing radiation, the accurate measurement of radiation doses has gained vital importance for radiotherapy and radiobiology and, with somewhat lesser accuracy, for radiation protection. Resulting from this development a dosimetry standard laboratory has recently been established at the Research Center Seibersdorf as a cooperative project between the "Austrian Atomic Energy Research Organization Ltd." and the "Austrian Federal Bureau of Standards". The task of this laboratory combines a national standard for radiation dosimetry with a routine calibration center for therapy and protection dosimeters.

## 2. LAYOUT OF THE LABORATORY

The design concept is based on the requirement to combine therapy level dosimetry (i.e. exposure rates ranging from 10 R/h to 100 KR/h) with protection level (10  $\mu$ R/h to 1 KR/h) as well as primary standards and routine calibration work within one building with minimum possible interference. This is in contrast to the situation of most of the dosimetry laboratories where protection- and therapy level work is usually separated and primary standard laboratories don't provide routine calibration. The economic advantage of this combination at least for a small country, however, lies in the fact that the same experienced personal and common equipment can be shared between the different duties. With a maximum degree of automation such operation can still cope with a considerable workload.

The building consists basically of a large, unshielded hall (20 x 8 m) for protection level work and a heavily shielded concrete bunker (8 x 4 m, wall thickness 70 - 150 cm) for therapy level dosimetry. Both rooms are operated from a common measuring and control room. The protection level hall is a light wood construction with wood/glasswool walls providing sufficient thermal insulation with negligible scattering. The radiation beams penetrate throughout the length axis of the hall into the open air. The environment of the building is partly protected by an earth wall. In addition the site is completely fenced-in and operated as temporary radiation area. This concept provides optimum physical measurement conditions at relatively low costs of construction.

## 3. RADIATION SOURCES AND FACILITIES

The laboratory (see enclosed diagram) is presently equipped for photon- and beta dosimetry. Later extension for basic neutron work is planned. For protection level dosimetry the beams of a 420 kV<sub>ap</sub> X-ray machine (PHILIPS

LAYOUT OF THE AUSTRIAN DOSIMETRY STANDARD LABORATORY

534

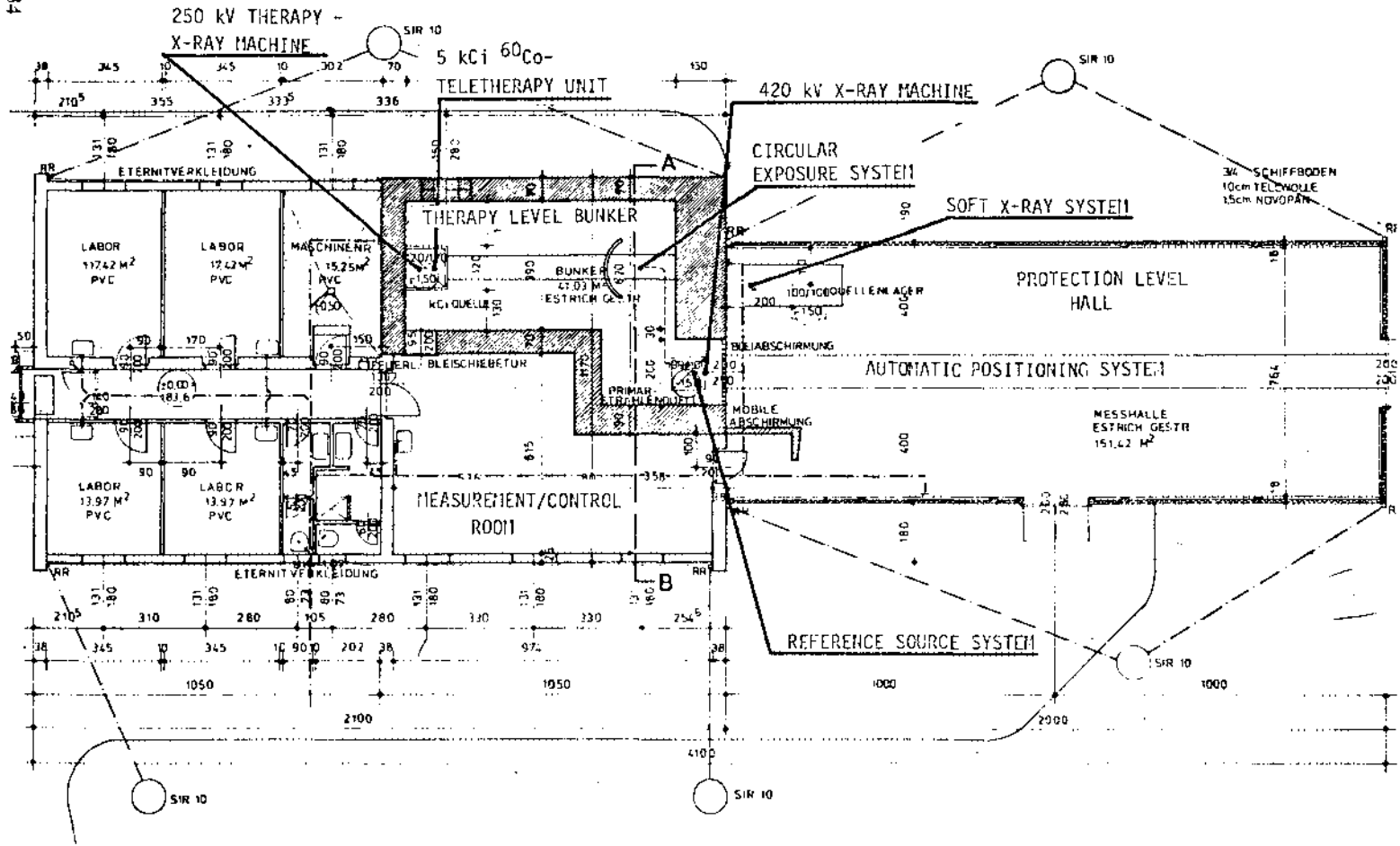

MS 420) and a specially designed reference source system are used. Both beams penetrate the center line of the hall with the X-ray beam 50 cm above the radium beams. Therefore the same automatic positioning system for the standards and detectors to be calibrated can be used. This system consists of a rigid cart running on tracks with a three-dimensional digital positioning system operated from the control room. Accuracy of positioning is better than 0.01 %.

The X-ray machine uses a metal-ceramic tube with Beryllium window and has been modified to operate from 30 kV<sub>pp</sub> to 420 kV<sub>pp</sub> and from 10  $\mu$ A to 10 mA.

An automatic filter tray for selection of 12 filters including a pneumatic shutter is attached.

The reference source system provides selection of six radium sources (<sup>226</sup>Ra and <sup>137</sup>Cs from 1 mCi to 30 Ci). When not used, the sources are stored underground in a shielded container within a well of 1.5 m depth. Finally a soft X-ray tube (MACHLETT DEB-80) with 1,5 mm Beryllium-window mounted on a calibration bench is available for the range of 5 to 80 kV<sub>pp</sub> X-rays.

The therapy level bunker contains a 5 kCi <sup>60</sup>Co teletherapy head (PICKER DB/M50) and a 250 kV<sub>pp</sub> therapy X-ray machine (SIEMENS Scatlipar). This unit also powers the soft X-ray tube. As in the protection level hall both beams are directed in the same axis one above the other and use a common manual cart/track system.

For routine batch calibration of personal dosimeters etc. in circular geometry a pneumatic exposure system with selection of four radioactive sources (<sup>226</sup>Ra and <sup>137</sup>Cs from 1 mCi to 10 Ci) is available. The source storage container is underground in the same wall as that of the reference source system.

For alignment of detectors and collimators a laser-levelling instrument with automatic levelling mechanism is mounted on the end of each track.

#### 4. COSMETRIC EQUIPMENT

Primary exposure standards include three Free-air Parallel-Plate Chambers of different size covering the X-ray range of 5 kV to 500 kV and a graphite cavity chamber of known volume (cylindrical 1 cm<sup>3</sup>) for gamma radiation.

In addition a series of air-equivalent secondary standard ionization chambers from 1 cm to 14 cm diameter are used. For beta radiation a commercial extrapolation chamber (PYCHLAL) and a set of calibrated beta sources are applied. The measurement of the ionization current is carried out with digital current integrators (OMI NP-2000) with variable measurement capacity. The addition of a calorimeter is planned in future. The electronic control and safety system has been specially designed for automatic measurement programs and computer data handling using microprocessor circuitry.

## DESIGN AND PERFORMANCE OF MAJOR BODY MONITORING FACILITIES

A. Knight, F.A. Fry, P.D.J. Whetmath and M.C. O'Riordan  
National Radiological Protection Board, Harwell,  
Didcot, Oxon, United Kingdom

## ABSTRACT

A description is given of major body-monitoring facilities recently installed in a new laboratory complex. They include a whole-body monitor, a low-energy photon monitor and associated electronic and data-processing equipment.

Careful selection procedures for the laboratory construction materials ensure low background. The effect of the main steel shield is documented in terms of Background Index together with the effect of the gradual addition of graded lining.

Details are provided of the control system for the whole-body monitor, including live time scan regulation and the reduction of end effects. The low-energy photon monitor, an array of dual phosphor detectors intended mainly for determining transuranic nuclides in lungs, is also described along with the pulse-shape analysis technique for background reduction. Difficulties such as subject background and tissue attenuation with incorporated nuclides that emit low-energy photons are discussed.

An account is provided of the control data-processing system which uses CAMAC and a small computer and to which several other spectrometric detectors are input.

Performance data of the equipment are briefly described.

## 1. INTRODUCTION

The body-monitoring facilities described in this paper were installed recently in the new headquarters building of the National Radiological Protection Board (NRPB) at Harwell. They replace the facilities (1) in the NRPB's former laboratories at Sutton where body monitoring was carried out by the Radiological Protection Service and by NRPB for nearly 20 years.

## 2. RADIATION BACKGROUND

The building materials used in the relevant part of the new building were specially selected for low radioactivity. Flint lime bricks made from Thames Valley aggregate are used.  $^{40}\text{K}$ ,  $^{226}\text{Ra}$  and  $^{232}\text{Th}$  levels in these bricks, which are also quite dense, are very much lower than the levels in alternative materials such as clay bricks or lightweight aggregate blocks (2).

The equipment is installed in a room constructed mainly from aged naval steel. The internal dimensions of the room are 4.8 m x 2.2 m x 2.0 m high. The steel is 15.2 cm thick except for the base which is 20.3 cm thick. The inside of the room is lined with 1 cm of aged lead and 0.2 cm of steel which successively absorb scattered and characteristic radiation. During and after construction, the Background Index (defined as the counts per

minute per cm<sup>3</sup> of NaI (Tl) crystal over the energy range 0.1 - 2 MeV) was measured. The following results are for a 15.2 cm diameter x 10.2 cm thick NaI (Tl) crystal, although some of the measurements were made with a smaller crystal and a volume correction applied (3). Background Index values were 0.39 for the bare steel room, 0.29 for the room lined with lead, 0.31 for the room lined with lead and steel and 0.34 for the completed room with equipment. Although the inner steel resulted in an increase in Background Index as defined above the background decreased by approximately the same relative amount in the low energy region of interest below 0.1 MeV.

Approximate radon daughter levels inside the steel room are 0.1 pCi/l RaA (<sup>218</sup>Po), 0.01 pCi/l RaB (<sup>214</sup>Pb) and 0.002 pCi/l RaC (<sup>214</sup>Bi). A filtered recirculating air system is used which provides 10 changes of air per hour and a make-up of up to 15% of fresh air. A constant temperature of 21°C is maintained in the steel room.

### 3. WHOLE-BODY MONITOR

The whole-body monitor is a scanning-bed type in which the bed moves on rails through a fixed steel ring of effective diameter 1 m. Six detectors, each consisting of a 12.7 cm diameter x 10.2 cm thick NaI (Tl) crystal and EMI 9530B photomultiplier tube, are mounted at 0°, 45°, 135°, 180°, 225° and 315° around the ring from the vertical. Each detector can be moved radially so that its face is between 10 and 35 cm from the mid-line through the centre of the ring. Each detector can also be angled up to ± 10° from the radial direction. All detectors can be fitted with easily detachable 2.5 cm thick aged-lead side shields. Profile scanning is possible by fitting the crystals at 0° and 180° with a further 2.5 cm thick side shield and also a 5 cm thick front shield with a single slit into which shaped slugs may be inserted.

The bed is driven by a drive shaft from a stepping motor. At present a linear scan is used. Scanning time can be varied, but is normally set at 30 minutes real time. There are two possible sources of error with this arrangement: lost counts due to a possible high dead time and non-uniformity of response. Dead time can be high due to the activity of the source under consideration, or because of simultaneous high count rate inputs to the data processing system described below, or because of other operations using this system. It is therefore desirable to control the speed of scan in live rather than real time.

The advantage of using a scanning system is that it is possible to obtain a response with reduced dependence on the distribution of the radioactivity within the body (4). With a constant scanning speed, however, end-effect errors occur. For example, the response to a point source falls to approximately 60% of its maximum value when the source is placed 90 cm from the centre of the bed. This can be corrected by varying the speed of scan during the scan to compensate for the reduced response.

A system for controlling the speed of scan in live time and for varying the speed is described below.

#### 4. LOW ENERGY PHOTON MONITOR

For the detection of low energy (10 - 100 keV) photon emitters in the body, for example plutonium in lung, dual phosphors similar in principle to those first used by Laurer and Eisenbud (5) are used. The system uses four commercially available dual phosphor detectors 127 mm in diameter, each with a 0.2 mm beryllium window and consisting of a 1.5 mm thick NaI (Tl) crystal optically coupled to a 51 mm thick CsI (Tl) crystal. This array of detectors is suspended from the ceiling of the steel room. A number of adjustments are provided so that detectors can be positioned closely above the body of the person being measured. The outputs of the 4 detectors are normally coupled in pairs, one pair viewing the upper areas of the lung, the other the lower areas.

Use is made of the difference in scintillation decay time of the 2 scintillators (250 ns for NaI (Tl) and 1000 ns for CsI (Tl)) to obtain a lower background in the energy region of interest by means of pulse shape analysis. Low-energy photons are totally absorbed in the thin crystal. Most higher energy unwanted photons penetrate the thin crystal, losing some energy in the process, and then interact with the CsI (Tl) crystal. The signal due to the low energy radiation will thus have the characteristic decay of NaI (Tl), and the signal due to extraneous high energy radiation will have a decay time which is mainly characteristic of CsI (Tl).

In brief, the pulse shape analysis system operates as follows. The photo-multiplier signal is processed by a delay line shaping amplifier the output of which is fed into an ORTEC 458 pulse shape analyser. This is set to generate a logic pulse when a photon interaction has occurred only in the NaI (Tl) crystal. This logic pulse then opens a linear gate to allow analysis by the data processing equipment. Typical backgrounds with no subject in position range from 1.5 to 3 counts per minute for each of the various detectors in the energy region 12 - 25 keV.

For in vivo measurements, the background will vary from subject to subject depending upon body build and the amount of  $^{40}\text{K}$  or of any other radio-nuclide in the body. A library of background spectra is being compiled using unexposed persons of different body build whose  $^{137}\text{Cs}$  and  $^{140}\text{K}$  contents are also being measured.

Analysis of results is further complicated by the absorption of low-energy photons within the body: for example, the half-value thickness in tissue for photons from  $^{239}\text{Pu}$  is only 0.6 cm. A chest phantom with a large rib cage and variable wall thicknesses of tissue-equivalent material is being developed for calibration purposes and is the subject of another paper at this Congress (6).

#### 5. DATA PROCESSING AND CONTROL SYSTEM

Signals from either the whole-body detectors or the low-energy photon detectors are fed to a CAMAC interface system under the control of a PDP 11/05 digital computer. The CAMAC system is provided with 8 separate analogue inputs which are routed via an 8 input mixer unit. An analogue signal from the mixer unit is fed to an analogue to digital converter (ADC) which has a resolution of 1024 channels and a 16 MHz clock rate. The mixer unit not only provides a single analogue output but also provides routing signals which are fed on to the CAMAC data highway in order that each analogue signal can be stored in a different part of the computer store. The PDP 11/05 computer has a 16k word store which is shortly to be increased



to 24k, and is under the control of an operator through a teletype writer console. Further data storage and programming facilities are being provided by means of a dual flexible disc unit. Output and input facilities to and from paper tape are provided.

The movement of the scanning bed is to be controlled via CAMAC as discussed above. The speed of the stepping motor and hence of the bed will be controlled through the CAMAC data highway by means of a suitable programme stored in the computer. This will enable a single scan to be made at a constant speed (linear scan) or to be divided into a maximum of 16 different speeds (from zero up to 60 cm per minute) to accomplish the necessary velocity profile for end effect correction. Use will be made of the 1 MHz CAMAC clock to provide a basic oscillator to drive the stepping motor. Dead time correction will be accomplished by means of the "BUSY" signal from the ADC which will be used to halt the bed drive temporarily while the ADC is processing a photon event.

## 6. PERFORMANCE DATA

Installation of the facilities described in this paper commenced in 1975; purchasing and commissioning of some parts of the data processing and control system are still taking place. Some preliminary performance data may however be of interest.

The low energy photon monitor has been installed for only a short time, and so far, most measurements on subjects have been to provide background spectra. Some measurements are also being performed on NRPB staff occupationally exposed to aerosols containing  $^{238}\text{Pu}$  and  $^{241}\text{Am}$ , but because of the early stage of development of the calibration phantom (6) it is not yet possible to quote a value for the minimum detectable activity (MDA).

The whole-body monitor, which was operational first, has been used for the assessment of body radioactivity in persons accidentally exposed to several radioactive materials including radium, thorium, uranium and  $^{89}\text{Y}$ . NRPB staff have been measured to provide calibration data for the low-energy photon monitor and to measure  $^{137}\text{Cs}$  levels. Typical MDAs, defined as twice the standard deviation of the background count over the background, for a 30 minute scan are 0.6 nCi of  $^{137}\text{Cs}$  for a uniform distribution in the body and 1 nCi of retained  $^{228}\text{Th}$  for a uniform distribution in bone.

## REFERENCES

- (1) UK 3.2 and UK 3.3. Directory of whole-body radioactivity monitors (1970 edition). IAEA, Vienna (1970).
- (2) HAMILTON, E.I., Am Ind Hyg. Ass. J. 32 (1971) 398-403
- (3) COURBOIS, Th., et al., Nucl. Instr. and Meth. 69 (1969) 93-100
- (4) PALMER, E.E., ROESCHER, W.C., Health Phys. 11 (1965) 1213-1219
- (5) LAURER, G.R., EISENBUD, M., in proceedings of symposium on Diagnosis and treatment of deposited radionuclides, Excerpta Medica Foundation (1968) 189-207
- (6) FRY, F.A., GREEN, B.M.R., KNIGHT, A., WHITE, D.R. "A realistic chest phantom for the assessment of low energy photon emitters in human lungs" these proceedings.

SOME CRITERIA FOR EVALUATION OF PERFORMANCE OF  
WHOLE BODY COUNTING SYSTEMS

A. Nagaratnam, M.M. Gupta, S.C. Mehta, G.C. Bhola,  
B.S. Rawat and K.K. Kapoor

Institute of Nuclear Medicine & Allied Sciences,  
Delhi-110007, INDIA

## 1. INTRODUCTION

Criteria for a whole body counter are high sensitivity and independence of detector response with respect to both source location and body build. One of the methods of assessment is to evaluate the following two parameters (1): (i) the average response  $\bar{R}$  as a point source is moved over a length of about 170 cm (height of adult), and (ii) the non-uniformity factor  $f_1 = (R_{\max} - R_{\min})/\bar{R}$ , where  $R_{\max}$  and  $R_{\min}$  are the maximum and minimum responses when the activity is concentrated at a point within the length of the source. The intervening medium is usually taken as air. The objective is to maximise  $\bar{R}$  consistent with a specified degree of non-uniformity of response (say,  $f_1$  less than 20%). In place of  $f_1$ , one could also use  $f_2$ , the coefficient of variation of the individual responses  $R$  (standard deviation of  $R$ 's divided by  $\bar{R}$ ).

## 2. MATERIALS AND METHODS

Three modifications have been introduced in the present study. The first consists in replacing  $\bar{R}$ , the average sensitivity, by a weighted average sensitivity  $\bar{R}_w$ , for the following reason. Whether it be clinical applications (e.g. body potassium, iron and vitamin  $B_{12}$  retention) or monitoring for internal contamination (critical organs mainly GI tract, bone, total body, kidneys, liver, lung) the majority of radionuclides have either a more or less uniform whole body distribution or are concentrated in organs located in the central regions of the body. In the case of whole body distribution, about 80% of the body mass is situated in the trunk, abdomen and thighs. Hence in all these situations, the central regions contain the bulk of the activity. (An exception is radioiodine in thyroid).

To take this factor into account, each segment of the line source representing the body has been weighted by a factor proportional to the mass of the body in that segment. The weighted average  $\bar{R}_w$  is likely to be a better parameter than  $\bar{R}$ .

Three cases have been considered, viz. 170, 150 and 100 cm of line source length,  $L$ , corresponding respectively to adult, adolescent and 3-year old child. Table 1 depicts the lengths and percentage masses of the six segments, based on the well-known Bush phantom for the adult and modified from the adolescent and child phantom data of Hayes and Brucer (2). The masses of the arms are added to those of the thorax and abdomen.

The next modification is to calculate a weighted non-uniformity factor  $f_{1w}$  or  $f_{2w}$  for the same reasons given earlier. The third modification is to consider the line source as sandwiched at the centre of a tissue equivalent medium of appropriate thickness  $2t$  (20, 16 and 12 cm for adult, adolescent and child respectively), to take into account effects of tissue absorption and body build.

The subject was taken to lie flat on a stretcher bed and computations were made for a single detector (to understand the pattern of variation) and 4-detector setup (the geometry used in our Institute), using IBM-360 computer for a variety of situations. Values of  $\bar{R}$ ,  $f_1$ ,  $f_2$  as well as the corresponding weighted parameters were calculated for a range of source-detector distances  $D_1$  (15-50 cm), 6 values of gamma ray energies (50-800 keV and also including no attenuation) and various detector configurations. Exponential attenuation was assumed (corresponding to photopeak counting).

### 3. RESULTS

#### 3.1. Single-detector

Fig 1 depicts  $\bar{R}$  and  $\bar{R}_w$  for the case of no attenuation for the adult for a source-detector distance of 25 cm as the detector is moved laterally from the head to the foot. It is seen that as against the obvious symmetric response for  $\bar{R}$ ,  $\bar{R}_w$  has a maximum when the detector is about 15 cm to the head side of the centre, in agreement with the observations of Miller (3) for a patient administered  $^{42}K$ . Further, the maximum value of  $\bar{R}_w$  is about 35% higher than that of maximum  $\bar{R}$ . This reduces to about 22% for a height of 45 cm, where one approaches more closely the arc geometry. The  $f_{1w}$  values are found to be much lower (about one-third) than the corresponding  $f_1$  values. As  $u$  increases,  $f$  values also increase.

#### 3.2. Four-detectors

The detectors were taken in two pairs, the members of each pair being situated symmetrically with respect to the centre of the line source.

By normalising  $\bar{R}$  with respect to a standard value  $\bar{R}_{max}$ , it has been possible to make broad generalisations for each type of detector positioning regarding average detector response which are reasonably independent of  $D_1$ ,  $\mu$ ,  $L$  or  $t$ . The standard  $\bar{R}_{max}$  is taken as the value of the response (for given  $D_1$ ,  $\mu$ ,  $L$ ,  $t$ ) when all four detectors are over the centre of the line source (Geometry A in figure 2). It is also found that  $\bar{R}_{max}(\mu)$  for any  $u$  may be found from the corresponding  $\bar{R}_{max}(0)$  for air, using the expression  $\bar{R}_{max}(\mu) = \bar{R}_{max}(0) \exp(-ut_{eff})$ , where  $t_{eff}$  is nearly independent of  $u$  and varies slowly with  $D_1$ . For example,  $t_{eff}$  for adult ( $t = 10$  cm) is about 12.8 cm. With regard to  $f_1$  and  $f_2$  such quantitative generalisations are not possible. Of course  $f$  is better for large  $D_1$ , small  $u$  or  $L$ .

Considering  $\bar{R}$  and  $f$  together, geometries A, B giving high sensitivity have poor  $f$  characteristics. Even for C,  $f$  is on the high side; only  $f$  varies here slowly with  $D_n$  and does not rise precipitously at low  $D_n$ . Geometry D with a sensitivity of 76% is extremely satisfactory from the point of view of  $f$ . The optimum positioning would therefore be around this geometrical configuration, with slight modifications improving the performance with respect to either or both  $\bar{R}$  and  $f$  (such as pushing the end crystals 5-10 cm towards the centre or lowering  $D_n$  for the end detectors about 5 cm with respect to the central one).

One may generalise that whenever there is a substantial difference between  $\bar{R}$  and  $\bar{R}_v$  such a configuration will have poor  $f$  values. For configuration D, there is very little variation between  $\bar{R}$  and  $\bar{R}_v$  irrespective of  $D_n$ ,  $L$  or  $u$ .

Body Region	Adult		Adolescent		Child	
	Length cm	% of total mass	Length cm	% of total mass	Length cm	% of total mass
Head	20	8.0	15	9.4	15	17.9
Neck	10	2.6	10	1.0	5	1.1
Thorax	40	41.8	35	40.9	25	39.8
Abdomen	20	26.0	20	22.5	15	23.4
Thighs	40	13.5	30	15.2	15	8.4
Legs	40	8.2	40	10.9	25	9.3
	170	100	150	100	100	100

TABLE 1 Lengths and Masses of Different Compartments for Adult, Adolescent and Child Phantom

#### REFERENCES

- (1) HUKKOO, R.K., UNNIKRISHNAN, K. "Optimisation of crystal positions in a multidetector-stretcher whole-body counting assembly - Program OCRYSP", Report BARC-505, India (1970)
- (2) HAYES, R.L., BRUGER, M. "Compartmentalised phantoms for the standard man, adolescent and child", Int. J. App. Rad. Isotopes, 9 (1960), 113
- (3) MILLER, C.E., "An experimental evaluation of multiple crystal arrays and single crystal techniques", p. 81-120, Proceedings of the Symposium on Whole Body Counting, IAEA, Vienna (1962)

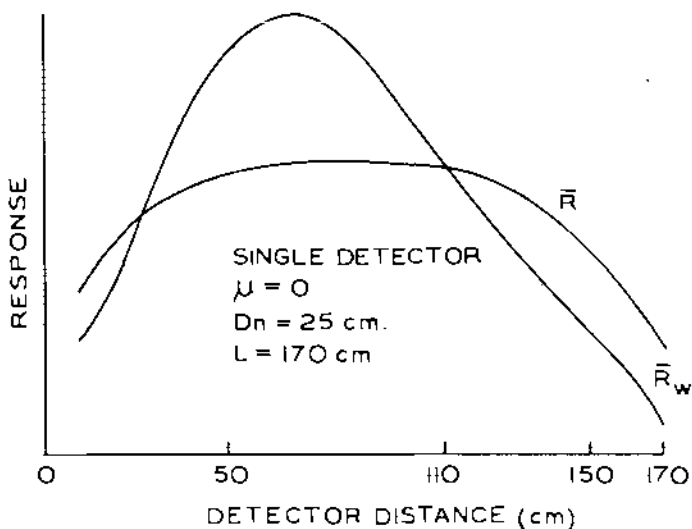

FIG.1  $\bar{R}$  AND  $\bar{R}_w$  VALUES

DETECTOR CONFIGURATION	$\frac{\bar{R}}{\bar{R}_{\max}}$ (%)	Range of $f_1$ values (%) as $D_n$ varies from 15-50cm ( $L=170$ cm., $\mu=0$ )
	100	400-130
	$93.7 \pm 1.8$	200-50
	$90.1 \pm 3.6$	110-50
	$76.4 \pm 2.5$	90-20

FIG.2  $\bar{R}$  &  $f$  VALUES FOR VARIOUS DETECTOR CONFIGURATIONS

**STUDIES ON IN VIVO CALIBRATION OF A PLUTONIUM LUNG MONITOR**

S. Somasundaram, R.C. Sharma, P. Kotrappa, T.K. Haridasan,  
Smt. T. Surendran, S.P. Garg, D.P. Bhanti and N.S. Pimpale

Health Physics Division  
Bhabha Atomic Research Centre  
Bombay 400 085, India

**ABSTRACT**

A phoswich assembly comprising a 20 cm x 3 mm NaI(Tl) primary detector and 20 cm x 5 cm CsI(Tl) secondary detector has been installed in the large steel room at BARC, Trombay for monitoring of chest burdens of plutonium and other transuranic elements. A special pulse-shape discrimination (PSD) circuit along with a multiplexer enables simultaneous and independent recording of pulses due to interactions of low and high-energy photons with the NaI(Tl) and CsI(Tl) layers respectively of the detector. The background of the primary detector in the 12 - 25 KeV energy band has been reduced by an order of magnitude at a loss in counting efficiency of 12-14%. To derive the counting efficiency for chest burdens of Pu-239, an in vivo calibration procedure is adopted. For this purpose, healthy volunteers inhale 'mock-Pu' aerosol consisting of polydisperse (AMAD 1  $\mu$ m,  $\sigma_g = 1.8$ ) polystyrene particles labelled with a mixture of Cr-51 and Pd-103. Cr-51 serves as a marker for the precise estimation of Pd-103 contents from which the calibration factor appropriate for chest burdens of Pu-239 is derived. The counting efficiencies for a subject-detector geometry and subject posture selected for routine monitoring are presented and discussed. The effects on the counting efficiency due to mode of breathing (nose/mouth), resulting in changes in deposition of the inhaled aerosol, are also investigated.

**Phoswich Detector System**

At Trombay a 20 cm dia phoswich detector (Quartz et Silice type Scintiflex 203YBE3) has been installed inside a large steel room (20 cm mild steel with no graded-Z lining) for monitoring lung depositions of insoluble Pu dust. Fig.1 shows the schematic diagram of the electronics system used for the detector. This system is essentially same as the one described by us in an earlier publication<sup>(1)</sup>; however, a few additional options have been introduced to achieve further reduction of background in the low energy bands. In addition, to facilitate the simultaneous and independent recording of information about low-energy and high-energy gamma interactions on a single 400 channel pulse-height analyzer, we have incorporated a two input multiplexer which aids in selecting either half of analyzer's memory depending upon the origin of signal pulse (Fig.1).

By pulse shape discrimination (PSD) alone we were able to reduce the background in (12-25 KeV) energy band to 10 cpm, i.e. by a factor of more than 5 in comparison to a thin NaI(Tl) detector; the loss in genuine signal was 10-12%. With the PSD operating, the background in low energies ( $< 25$  KeV) was still higher than expected. Cosmic ray inter-

actions showing saturated pulses were observed to cause electronic artifacts in the form of bleed off monopolar pulses occurring after a lag of about 100  $\mu$ sec or so, whose rise-times were similar to those of NaI(Tl) pulses. Electronic elimination of such pulses, not rejected by rise-time discrimination, was carried out by options B & E shown in Fig.1. Option E is essentially an overload rejection and inhibits the output of spectrometry pulses for about 300  $\mu$ sec, the moment any saturated pulse is detected. Option E serves to limit the energy band desired. Though the combined effect of these measures was a reduction in the background (12-25 KeV energy band) by more than 1 cpm, the shape of the low energy pulse-height spectrum appeared to show some unrejected components.

Experimental evidence indicated that the PSD perhaps did not reject some noise pulses, having rise-times similar to those of NaI(Tl) pulses. We have not yet been able to identify the source of such noise pulses but their presence has been established beyond doubt since when, in addition to all other options the output of the last dynode of phototube is operated in coincidence with that of the anode, the low energy background (12-25 KeV) is reduced by a factor of almost 2 (Option C in Fig.1). This results in further signal loss; however, when the time window for NaI(Tl) in the PSD channel is widened to compensate for signal loss, the overall reduction in background observed is similar.

Finally, another option D has been incorporated to substantiate PSD criterion by inserting CsI(Tl) output in anticoincidence to the spectrometry signal. Thus the phoswich detector at Trombay has been in operation with the measures of PSD, overload rejection and energy band restriction, last dynode coincidence and PSD substantiation. The overall loss of the genuine signal for low-level counting has been adjusted to 12-14%; PSD alone accounts for 8%. The resultant background in (12-25 KeV) region is 4-5 cpm; almost an order of magnitude less than expected from a thin NaI(Tl) per se. The shape of the background spectrum does not seem to indicate the anomaly observed earlier as is clear from Fig.2 which also shows the effects of incorporated options.

#### In Vivo Calibration

The inadequacy of in vitro calibration methods for assessment of low energy x-ray emitters in lungs is well recognised.<sup>(1,2)</sup> While some effort is being made to improve chest phantoms to make them more realistic, we believe that simulation of radioactive aerosol distribution within the lung and that of human posture would still remain as uncertain factors, although the extent of uncertainty may be known. We prefer in vivo calibration of the system, involving inhalation of 'mock-Pu' by human volunteers. The mock-Pu used in the present studies is polydisperse polystyrene aerosol ( $M_{w}/M_{n} = 1.0 \mu\text{m}$ ;  $\sigma_g = 2.0$ ) labelled with Pu-103 (20.2 KeV) and Cr-51 (323 KeV). The technique of aerosol generation and inhalation by human volunteers are same as those described by us earlier.<sup>(1)</sup> Three more volunteers inhaled dual (Pu-Cr) labelled aerosols by nose. In order to ascertain the effects of the mode of breathing, two volunteers inhaled by mouth aerosols labelled with Cr-51 only. Normal breathing patterns were maintained as far as possible. The maximum amounts of these radionuclides deposited in lungs and subjected to long-term elimination were less than 1  $\mu\text{Ci}$  in most cases.

## Measurements & Results

The measurement techniques were essentially the same as those described by us earlier.<sup>(1)</sup> From chest contents of Cr-51, measured by Cs(Tl) secondary detector of phoswich and Cr-51/Pd-103 ratios, estimates of Pd-103 lung contents were obtained. The counting efficiencies E(count per photon emitted by Pd-103 in lungs) were calculated from the observed counting rates from subjects in (18-30 KeV) energy band covering the 20 KeV photopeak. Since our earlier data<sup>(1)</sup> had been adjusted to 6% signal loss as a result of phoswich operation, the present data have also been adjusted to the same loss. For mouth breathers who inhaled aerosol labelled with Cr-51 only, supine and prone measurements on the chest were carried out for more than 30 days. In addition, ultrasonic measurements of chest wall thickness (CWT) were carried out for 60 Indian subjects in arms by side posture and the data fitted by a least square straightline, as a function of W (Kg)/H (cm) ratio which yielded the regression equation.<sup>(2)</sup>

$$\text{CWT (cm)} = 0.812 + 3.75 (W/H); \sigma = 0.19 \text{ cm}$$

This equation was used to get CWTs of the subjects in earlier experiments.

The results from the present series are similar to those obtained in our first experiment.<sup>(1)</sup> Fig.3 shows the correlations of counting efficiencies for Pd-103 and Pu-239 in lungs with CWT of the subject in arms by side posture, the single phoswich being placed centrally over the chest. As was expected, better correlation was obtained with CWT than with chest circumference. The method of converting Pd-103 counting efficiency to that for Pu-239 in lungs is the same as reported earlier.<sup>(1)</sup> Fig.3 shows also the variations of the corresponding limits of detection for Pu-239 in lungs with CWT. These results which predict 0.76 and 0.62 cm as half-value thickness of tissue for Pd-103 and U<sub>L</sub> x-rays respectively are given for the counting geometry used at Trombay for routine monitoring of chest burdens of Pu. The results have been normalised to the same ratio of counts in Cr-51 photopeak from front to back.

The results from the two mouth breathers indicate similar biological half-lives for clearance from lungs as in the case of nose breathers. It appears that in general the pattern of activity deposition in lungs is similar, as is indicated by the ratio of Cr-51 photopeak from front and back in the case of nose and mouth breathers.

## Acknowledgement

The authors express their sincere thanks to Mr. D. Newton (AERE, Harwell) for helpful discussions. They are grateful to Dr. A.K. Ganguly (Director, Chemical Group, BARC) and Mr. S.D. Soman (Head, Health Physics Division, BARC) for their keen interest in the work.

## References

1. SHARMA, R.C. et al, in "Diagnosis and Treatment of Incorporated Radionuclides", Proc. of a Symposium, IAEA, Vienna (1976) 177-201.
2. SHARMA, R.C. et al BARC-Report (under preparation).
3. HARIDASAN, T.K. et al Ultrasonic measurements of chest wall thickness in Indian subjects (Paper to be presented at the Fourth Annual Conference on Radiation Protection, Madras, March 12-14, 1977).



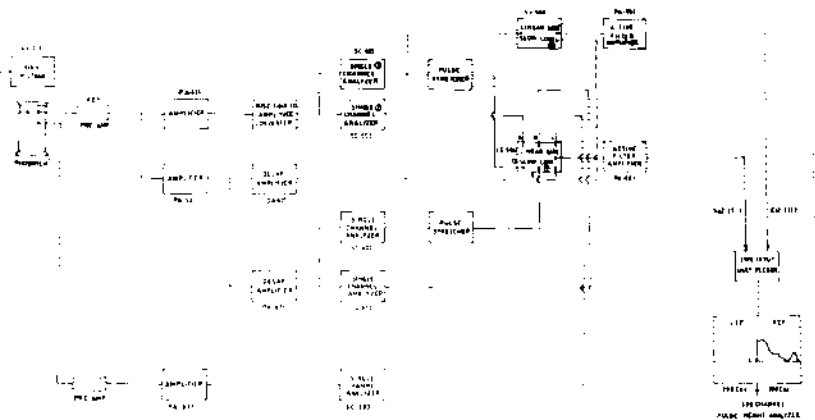

Fig.1 SCHEMATIC DIAGRAM OF ELECTRONICS FOR PHOSWICH DETECTOR

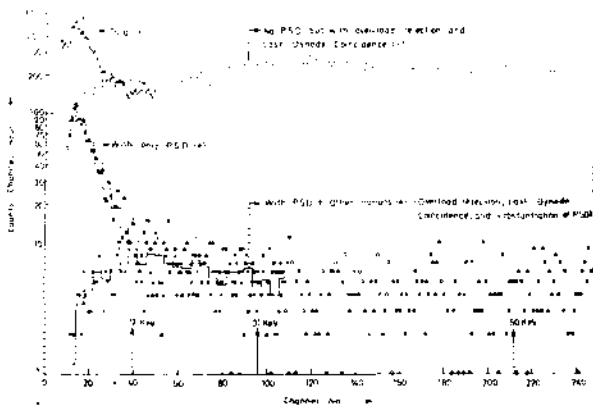

Fig.2 Low energy background spectra from phoswich inside Trombay steel room under different operating conditions. Histograms depict 5 point averages

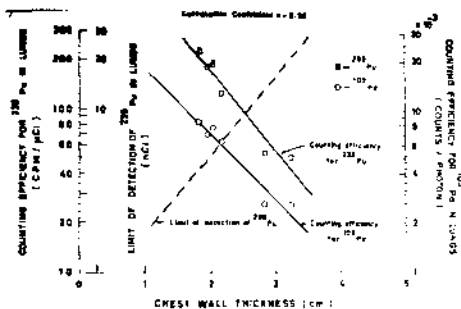

Fig.3 Correlations of counting efficiencies for Pu-103 and Pu-239 in lungs with chest wall thickness (CWT) of subjects in arms by side posture

APPLICATION OF IMAGE DETECTOR TO EXTERNAL COUNTING OF LOW ENERGY  $\gamma$ -EMITTERS IN LUNGS

T. Shirotani and M. Fujita

Japan Atomic Energy Research Institute  
Tokai-mura, Ibaraki-ken, Japan

## 1. INTRODUCTION

In the interpretation of the results of "in vivo" counting of Pu-239, U-235 or some low energy  $\gamma$ -emitters in the lungs, the variation of geometrical efficiency due to the difference of activity distribution within the lungs should be taken into account, because the distribution may not always take the same pattern, for example, homogeneous as assumed normally, after an inhalation incident.

In order to make corrections for the variation of the geometry, we have developed a new type lung monitor capable of estimating roughly the pattern of activity distribution in the lungs, by introducing the idea of scintillation camera proposed by Anger (1). For low level contamination of the order of the maximum permissible lung burdens, the lung monitor can not display finely the image of activity distribution, but can give rough distribution from the comparison of the counting rates within each area of image divided into halves or quarters.

This paper describes the detector system and the preliminary calibration of the detector

## 2. DETECTOR AND ELECTRONICS

The designed detector consists of a 23.7 cm diameter by 1.2 cm thick NaI(Tl) crystal with a Be window and a hexagonal array of seven 3 inch diameter photomultiplier tubes (FMT 9708R) coupled optically with a Lucite light pipe of 3 cm thick. The size of the crystal was determined in consideration of the background counts in a shielding room and the thermal noise from the photomultiplier tubes for the detection of the LX-rays of Pu in the lungs. The block-diagram of electronics is shown in Fig. 1. The energy selector (attenuator) in the first stage was designed in particular for the purpose of health physics. The energy range covered by the selector is from 50 to 450 keV. The distribution of activity of Pu in the lungs is estimated by detecting the 60 keV  $\gamma$ -rays from Am-241 contained in the Pu. The oscilloscope is usually used as a Z-pulse monitor, and also used for the adjustments of the position and the linearity of the image on the screen, rather than displaying a visual image of activity distribution within the lungs of an exposed subject.

## 3. PRELIMINARY CALIBRATION

The experiments for calibration were done in a shielding room. The detector was centrally positioned 1 cm from the chest of a supine phantom, with the edge of the detector window above the clavicle. The phantom used in the calibration was the Average-Woman Rando Phantom without breast. Table 1 shows the fundamental characteristics of the detector in the ordinary use as a lung monitor. The minimum detectable amounts, defined as 3 standard deviations of background counts, in the Table were obtained for a subject with an effective tissue thickness of 3.1 cm over the lungs. The details are given in Ref. (2).

### 3.1. Image Resolution

The overall image resolution, defined as a distance at which two point sources can be barely distinguished, is about 2.3 cm, when a multichannel collimator (hole diameter: 5 mm, hole length: 2.5 cm, number of holes: 1000) is employed and the source (Am-241) to detector distance is 5 cm.

### 3.2. Estimation of Activity Distribution

Figure 2 shows the variation of the relative counting efficiency due to the difference of the source distribution in the lungs. The curves in the Figure show that the decrease of the efficiency in the localized distributions such as (6) and (7) is so large that the decrease can not be neglected.

The estimation of activity distribution in the lungs was made by means of "1/2 or 1/4 image divide counting method" as illustrated in Fig. 3. We obtained the 1/2 and 1/4 image divide counting ratios for many different source distributions, using the phantom with Am-241 or 20% enriched U sources in the lungs. Table 2 gives only the results for four distribution patterns, (1), (5), (7), and (9). The figures in parentheses are the values obtained with a multichannel collimator which has large square holes (hole size: 2 cm x 2 cm, hole length: 2.5 cm, number of holes: 100) designed in particular for the image divide counting method. By using the collimator, the counting efficiency decreases to about 0.15 under the condition of homogeneous distribution. Comparing the data in the Table, obtained with or without the collimator, we find that it is possible to estimate the distribution of activity, without the collimator, to the extent that we can judge whether correction of the counting efficiency is necessary or not.

In the case of low level contamination, the distribution is estimated from the 1/2 image divide counting ratio. In a localized distribution where the counting efficiency decreases more than 30%, i.e., the observed 1/2 counting ratio becomes less than 0.4, the calibration factor obtained from homogeneous distribution should be modified suitably. The minimum activity required for the determination of the distribution, defined as 3 standard deviations of background counts in the contaminated area of the lungs, is 0.11 nCi for the Am, and is 210  $\mu$ g for the U at the distribution (1). For the distribution (7), these values become 0.16 nCi and 290  $\mu$ g, respectively.

## 4. CONCLUSION

By using the "image divide counting method", we can determine the rough distribution of low energy  $\gamma$ -emitters in the lungs of an exposed subject, and can decide whether the correction for the calibration factor is necessary or not. This method is proved to be practical and useful from the results of actual measurements of persons exposed to Hg-197. By the method, we can also estimate the variation of the distribution with time, and the influence of activity transferred to the liver on the lung counting.

## REFERENCES

- (1) ANGER, H.O., Rev. Sci. Instrum., 26, 27 (1958)
- (2) SHIROTANI, T., Nucl. Sci. Technol., 12, 442 (1975)

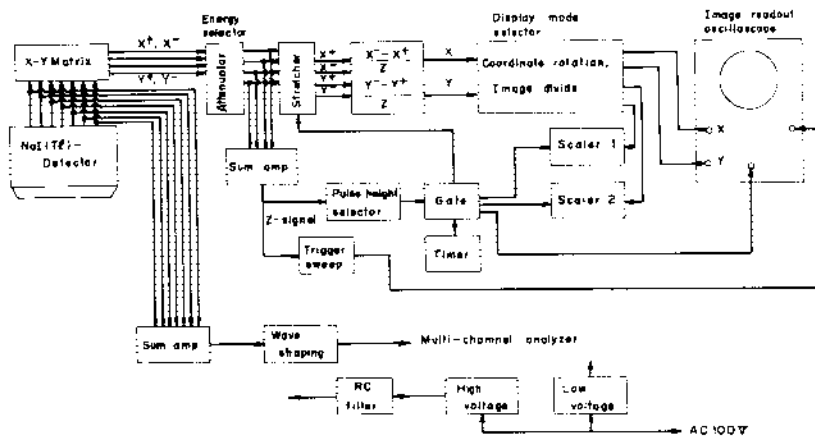

Fig. 1 Electronics of Scinti-Camera Type Lung Monitor

Source		Pu <sup>(1)</sup>	Am	U <sup>(2)</sup>	
Energy range (keV)		Pu - band (12-26)	Am - band (45-75)	Th - band (53-120)	U - band (151-210)
Background (cpm)	Iron room	93.6	127.0	282.0	151.0
	Normal subject <sup>(3)</sup>	106.0	215.0	420.0	256.0
Counting efficiency		0.69 cpm/nCi	71.3 cpm/nCi	62.5 cpm/mgU	39.4 cpm/mgU
Minimum detectable amount	60 min.	6.4 nCi	0.08 nCi	—	161 µgU
	100 min.	4.9 nCi	0.06 nCi	—	123 µgU

(1) Contained 97.3 % Pu-239, (2) 20 % enriched U-235  
 (3) K = 120 g, Cs-137 = 2nCi

Table 1 Fundamental Characteristics of the Lung Monitor

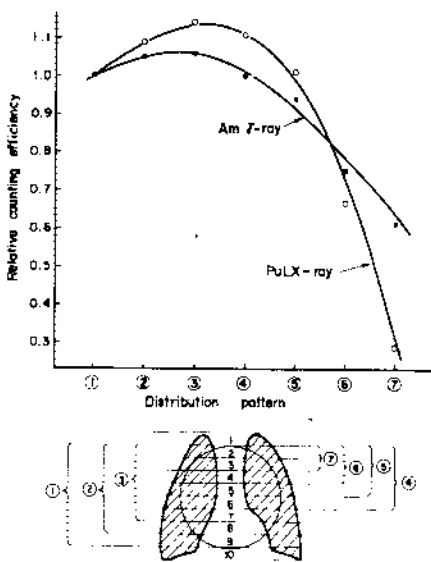

Fig. 2 Relative Counting Efficiencies in Different Source Distributions

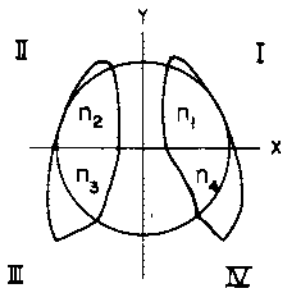

Fig. 3 Image Divide Counting Method

$n_1, n_2, n_3,$  and  $n_4$ : net counting rates in each divided area

1/2 image divide counting ratio  
 $= (n_1 + n_2) / (n_1 + n_2), (n_3 + n_4) / (n_1 + n_2),$

1/4 image divide counting ratio  
 $= n_1/n_1, n_2/n_1, n_3/n_1, n_4/n_1$

Source distribution pattern	①		②		③		④	
	1/2	1/4	1/2	1/4	1/2	1/4	1/2	1/4
<sup>241</sup> Am (60keV±25%)	1 (1)	0.89 (0.89)	1 (1)	0.82 (0.76)	1 (1)	0.82 (0.65)	1 (1)	0.48 (0.35)
	0.77 (0.74)	0.72 (0.69)	0.74 (0.70)	0.42 (0.29)	0.35 (0.24)	0.40 (0.28)	0.23 (0.03)	0.18 (0.02)
							0.21 (0.02)	0.30 (0.10)
								0.15 (0.03)
								0.31 (0.12)
<sup>235</sup> U (80keV±15%)	1 (1)	0.98 (0.97)	1 (1)	0.83 (0.82)	1 (1)	0.91 (0.66)	1 (1)	0.63 (0.35)
	0.88 (0.87)	0.90 (0.84)	0.94 (0.87)	0.43 (0.22)	0.34 (0.15)	0.42 (0.18)	0.24 (0.04)	0.19 (0.02)
							0.21 (0.03)	0.29 (0.08)
								0.18 (0.03)
								0.40 (0.08)

Table 2 1/2 and 1/4 Image Divide Counting Ratios Obtained with or without Collimator

ENERGY DEPENDENCE MEASUREMENTS OF REMMETERS AND ALBEDO NEUTRON DOSIMETERS  
AT NEUTRON ENERGIES OF THERMAL AND BETWEEN 2 keV and 5.67 MeV\*

Dale E. Hankins  
Lawrence Livermore Laboratory  
P.O. Box 808  
Livermore, California 94550

## 1. INTRODUCTION

Standard neutron fields for calibrating and developing neutron instruments and dosimeters have been established through a joint effort of ERDA's Division of Operational Safety (DOS) and the National Bureau of Standards (NBS), Center for Radiation Research. This program provides monoenergetic neutron beams in the intermediate-energy range, thermal neutron beams, monoenergetic fast neutrons, and standard neutron fields.

The intermediate-energy neutron beams are from the NBS reactor, and have predominant energies at 2.0, 25 and 144 keV. The beams are obtained by using a combination of resonant scatterers and filters. They are of high intensity, have low backgrounds of other energy neutrons and gamma rays, and are well calibrated and stable. The 2-keV beam is of particular interest since it provides a calibration point which is about one decade in energy lower than has been available previously. We also made measurements at neutron energies between 30 keV and 5.67 MeV, obtained from the Lawrence Livermore Laboratory cyclotron accelerator.

## 2. PROCEDURE

The instruments used were the 9-in.-sphere Portable Neutron Rem Counter (1,2) Model PNR-4 manufactured by Eberline Instrument Corporation, Santa Fe, NM, and the Andersson-Braun (A-B) type Remmeter (3) built to LLL specifications. Data were obtained from the A-B remmeter exposed with the side and the end toward the source. The albedo neutron dosimeters were the Hankins-type (4) which have cadmium completely surrounding the TLDs. Additional results were obtained by placing TLDs on the bottom of the albedo dosimeter (between the dosimeter and the phantom) to simulate the simpler type albedo dosimeter.

The thermal and intermediate-energy neutron beams from the NBS reactor are small (~4.3 to 8.9 cm diam) requiring that the instruments or phantoms be placed on a scanning table. This table moves at a constant speed horizontally and in steps vertically. The table can be programmed to scan the area desired. The cyclograph results were obtained by supporting the instruments or phantoms on tripods in a low-scatter target room.

The pulse outputs of the instruments were obtained from the scaler or phone jacks and fed to a portable scaler Model PS-1 manufactured by Eberline Instrument Corporation. The albedo neutron dosimeters were placed on a chest manikin filled with water. Dose rates and fluences were determined using distances measured from the center of the source to the geometric center of the instruments or to the face of the phantom.

## 3. DISCUSSION OF DOSE-EQUIVALENT CONVERSION FACTORS

The conversion factors from fluence to dose equivalent is given in NCRP Report No. 38 for specific neutron energies (5). For energies other than those given, it is recommended that "linear interpolation between neighboring energies" given in the report be used. The accuracy of this procedure, which gives a peculiar shape to the dose-equivalent curve when plotted on semilog or log paper, was questioned. However, calculations by Poston and Jones (6), using the same computer program that was used to calculate the values given in NCRP-38, indicate that for neutron energies of 2, 25 and 144 keV, the procedure gives values very close to the calculated conversion factors. All results in this study requiring dose equivalent were evaluated using the linear interpolation procedure (at 2, 25 and 144 keV, these are 272.9, 241 and  $42.9 \text{ cm}^{-2} \text{ s}^{-1}$  respectively).

\* Work performed under the auspices of the U.S. Energy Research and Development Administration, under contract No. W-7405-Eng-48.

#### 4. RESULTS

The results obtained in this study are given in Table 1. Figure 1 shows the relative response as a function of neutron energy of the 9-in. sphere and the A-B remmeter respectively. The calculated response of each instrument is also plotted, and these agree well with measured points except at energies below about 100 keV where the calculated responses are lower. The dose-equivalent curve is shown (see preceding paragraph) to illustrate the relationship between the desired and the actual response of the instruments.

Figure 2 shows the response curve for the 9-in. sphere and A-B remmeter which were drawn by using the results obtained in this study, and the measured

9-in. sphere			3-in. sphere		Anderson-Braun remmeter				Albedo neutron dosimeters					
Dose rate Calc.	Rate Obs.	Counts (n/cm <sup>2</sup> /s)	Counts (n/cm <sup>2</sup> /s)	Ratio 9/3	Side		End		Ranking type	Under Cd				
					Dose Rate Calc.	Obs.	Rn/in End/side	Counts (n/cm <sup>2</sup> /s)			Dose rate Calc.	Obs.	Counts (n/cm <sup>2</sup> /s)	
<u>Springer</u>														
30 keV	0.55	1.61	7.58	37.1	0.224	0.63	1.92	0.73	14.9	0.44	1,988	10.9	10.25	31.8
49.7 keV	0.318	1.88	9.85	43.3	0.228	0.318	1.11	0.78	22.7	0.122	2,852	17.26	-	-
70 keV	1.70	7.23	10.74	44.7	0.239	1.63	4.58	0.73	24.42	1.94	3,20	18.06	5.92	18.8
100 keV	5.82	9.85	11.59	43.8	0.265	5.82	6.72	0.75	19.3	5.32	4.61	21.9	1.39	6.0
146	2.04	3.70	13.03	38.3	0.343	-	-	-	-	-	-	-	-	-
200	2.28	3.96	14.09	33.4	0.422	2.21	2.97	0.74	42.66	2.22	2.20	31.5	1.16	3.6
300	3.07	4.53	15.68	30.0	0.522	3.16	4.08	0.69	53.30	1.08	2.92	38.5	0.865	-
330	2.99	4.30	18.08	28.8	0.628	2.99	3.70	0.74	60.98	2.99	2.72	44.9	0.701	-
400	5.43	6.16	18.22	29.8	0.617	6.34	6.34	0.78	58.5	5.43	4.10	45.3	-	-
500	61.84	47.0	22.47	33.3	0.966	48.4	35.61	0.73	80.6	53.5	28.92	59.2	0.231	0.949
580	21.1	16.5	22.34	20.1	0.900	17.4	12.8	0.73	81.6	17.5	9.4	59.9	-	-
700	10.5	8.17	24.12	22.3	1.08	10.6	9.07	0.92	103.8	10.6	8.34	93.7	-	-
800	11.9	8.80	24.66	20.1	1.23	11.9	10.09	0.89	110.2	11.9	8.97	98.0	-	-
1 MeV	43.2	32.5	30.31	17.9	1.70	43.5	16.5	0.74	128.3	51.7	31.7	85.5	0.135	0.383
1.2 MeV	16.4	12.76	30.05	18.3	1.85	16.3	14.47	0.88	133.0	16.3	12.65	116.8	-	-
1.476	41.0	31.9	30.81	13.2	2.32	33.7	29.8	0.80	137.5	39.5	27.8	109	0.0900	-
2.0	37.8	29.2	31.77	12.8	2.48	38.2	35.0	0.78	139.6	39.1	28.0	109	0.104	-
3.033	17.3	12.9	30.29	13.0	3.27	17.2	14.6	0.79	135.2	17.7	11.9	107	0.0788	-
5.666	48.7	28.1	29.88	6.32	4.59	56.0	38.2	0.89	152.8	56.8	32.6	111	0.0384	-
4.52	-	-	-	4.21	-	-	-	-	-	-	-	-	-	-
<u>N.B.S.</u>														
Thermal	3.41	3.31	1.11	0.765	1.45	3.40	1.21	0.36	1.61	3.40	0.440	0.560	0.281	37.0
2 keV	2.05	11.3	6.23	46.7	0.133	2.06	5.47	0.61	11.9	2.05	1.33	7.21	17.7	48.7
25 keV	0.369	2.58	5.00	42.1	0.214	0.369	1.47	0.68	19.9	0.369	1.00	13.3	11.5	35.7
146 keV	38.8	66.6	12.4	32.6	0.381	39.0	44.7	0.68	32.6	38.9	20.4	22.2	1.46	-

TABLE 1 Results Obtained with the Instruments and Dosimeters at the Various Neutron Energies

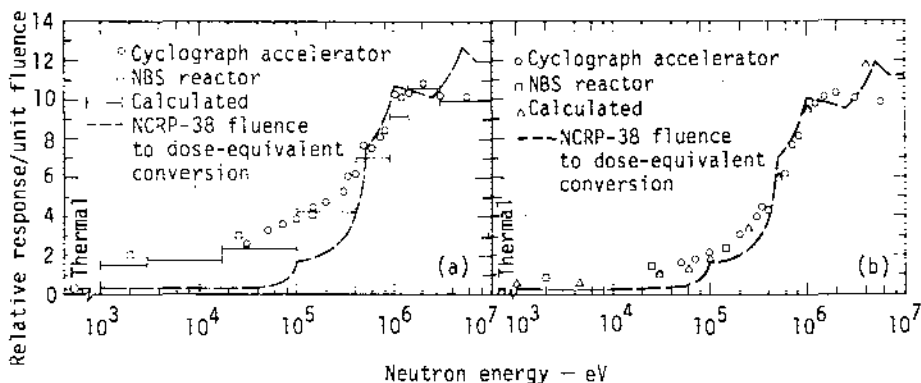

Fig. 1. Observed and calculated responses; (a) a 9-in.-sphere remmeter; (b) an A-B remmeter exposed with the side of the instrument toward the source.

response of the 8- and 12-in. spheres.<sup>7</sup> The irregular shape of the curve above 2 MeV is caused by the cross-section resonances of carbon.

Figure 3 shows the relative response of the two remmeters when compared to the calculated dose equivalent. The apparent underresponse between 400 keV and 6 MeV is probably caused by an error in our calibration procedure. The overresponse of the 9-in. sphere rises to a maximum of about a factor of 7 at 25 keV compared to a factor of  $\sim 4$  for the A-B remmeter. Below 10 keV the overresponse becomes less, and at thermal the 9-in. sphere response is correct, but the A-B remmeter is low by a factor of 3.

Figure 4 shows the ratio of the 9-in.-sphere remmeter and the 3-in., 10-mil, Cd-covered sphere. The ratio of the 9- to 3-in. spheres is used to determine the calibration factor for albedo neutron dosimeters (4-8). This ratio can also be used to determine the average neutron energy, but care should be used in applying average energies since they can be misleading. Figure 5 shows the results obtained with albedo neutron dosimeters. A curve is shown for the response of the Hankins-type albedo neutron dosimeters and for TLDs taped to the bottom of this dosimeter. The two curves are similar, indicating that changing the TLD location does not cause a change in the energy dependence of the dosimeter. The calculated values are from Alsmiller and Barish (9), and were made for the Hankins dosimeter. Very good agreement is found between experimental and observed results.

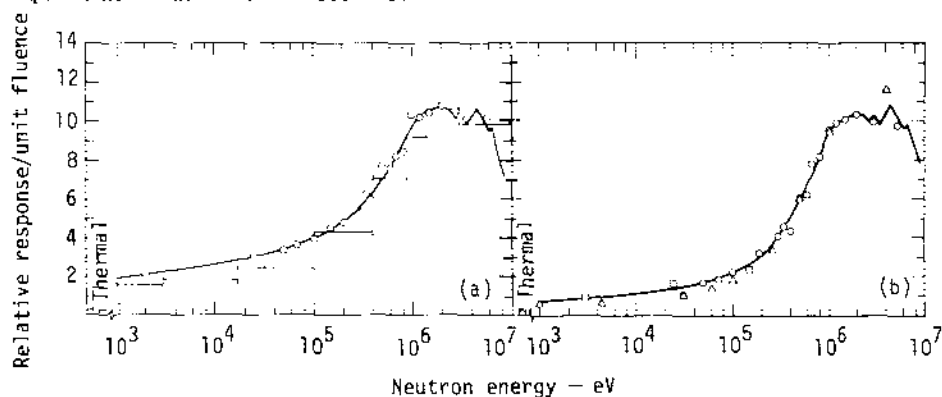

Fig. 2. Energy response curves based on results observed in this study, and measured energy response of 8- and 12-in. Bonner spheres; (a) 9-in.-sphere remmeter, and (b) an A-B remmeter.

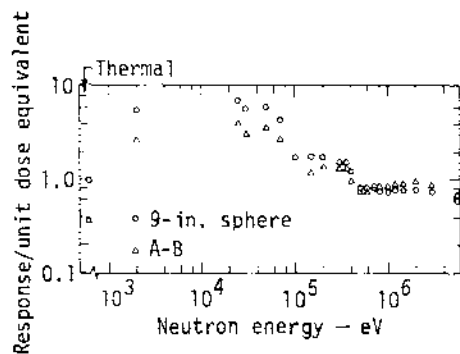

Fig. 3. Response of the 9-in.-sphere remmeter and A-B type remmeter per unit of dose.

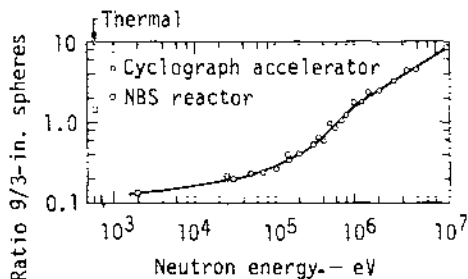

Fig. 4. Ratio of response of the 9-in.-sphere remmeter to the response of the 3-in. 10-mil Cd-covered sphere.



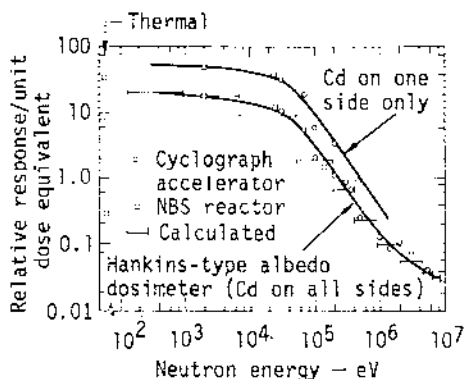

Fig. 5. Curves showing the energy dependence of the Hankins-type albedo neutron dosimeter and of TLDs taped to the bottom of the dosimeters. Also shown is calculated response by Alsmiller and Barish.

## 5. DISCUSSION AND SUMMARY

The use of the NBS facilities has allowed us to extend the measured response of remmeters and albedo neutron dosimeters about 1 decade lower in energy than has been possible previously. The NBS and cyclograph exposures were made with greatly differing experimental procedures, but the results plotted in Figs. 1 and 5 at overlapping energies show good agreement. This gives us confidence in the accuracy of both experimental procedures.

The results given in Fig. 5 indicate that the 9-in. sphere would give a higher over-response to spectra containing a large component of intermediate energy neutrons. A recent study (10) comparing the readings of these two instruments indicates that no detectable difference was found except at the LFR reactor where the 9-in.-sphere readings were higher than the A-B remmeter readings.

The directional response of the A-B remmeter is given in Table I. The reading of the instrument when exposed to the end is consistently lower than the side reading and at thermal neutron energies, the end reading is low by a factor of  $\sim 8$ . This low response to thermal neutrons and the directional response to both thermal and fast neutrons encouraged us to redesign the A-B remmeter. This work has recently been completed (10).

## 6. REFERENCES

- (1) HANKINS, D. E., Los Alamos Scientific Laboratory, Rept. LA-3595 (1967)  
Reference to a company or product name does not imply approval or recommendation of the product by the University of California or the U.S. Energy Research & Development Administration to the exclusion of others that may be suitable.
- (2) HANKINS, D. E., Health Phys. 14 (1968) 518
- (3) ANDERSSON, I. O. and BRAUN, J., Nukleonik 6 (1964) 237
- (4) HANKINS, D. E., Los Alamos Scientific Laboratory, Rept. LA-5261 (1973)
- (5) National Council on Radiation Protection and Measurement (NCRP) Rept. 38, Washington, D.C. (1971)
- (6) POSTON, J. W. and JONES, T. D., personal communication (1976)
- (7) BRAMBLETT, R. L., EWING, R. I., and BONNER, T. W., Nucl. Instr. Methods, 9, (1960) 1
- (8) HANKINS, D. E., Proc. 9th Midyear Topical Symp., Health Phys. Soc., Denver, Colo., (1975) pp. 861-868
- (9) ALSMILLER, R. G., Jr., and BARISH, J., Oak Ridge National Laboratory, Rept. ORNL-TM-3984 (1972)
- (10) HANKINS, D. E., paper to be presented at the 1977 Health Phys. Soc. Meeting, Atlanta, Ga. (Preprint UCRL-78928) (1977)

MODIFIED TARGET THEORY - DOSIMETRIC IMPLICATIONS

D.L. Watt  
 Department of Medical Biophysics  
 The University  
 Dundee. DD1 4HN.  
 Scotland, U.K.

Introduction.

Conventional dosimetry systems based on energy parameters such as absorbed dose and LET become invalid for heavy charged particles (e.g. H, C, N and O ions) at energies near and below the Bragg peak because (i) the LET is not single valued and consequently there is ambiguity in the dose-response relationship, and (ii) there are competing types of energy absorption process which may act with different degrees of effectiveness. This has important practical consequences in the dosimetry of intermediate energy neutrons and of heavy particles near the end of their range.

In the following discussion target theory (1) is re-explored and modified in the light of modern knowledge. The choice of parameters for conventional dosimetry systems is considered and an alternative approach which could lead to a new universal system of dosimetry is suggested. For illustrative purposes comment is confined to the simple target, single hit theory but it should be borne in mind that the ideas are easily extended to more complex situations.

Basic Target Theory.

Good correspondence with the general shape of dose-response curves is obtained by assuming the stochastic nature of radiation interactions and that Poisson statistics apply. Thus the survival probability  $P_1$  for single hit inactivation is given by

$$P_1 = e^{-vC} \text{-----(1)}$$

where 'v' is the geometric volume of the sensitive site and C is the concentration of hits per unit volume. When the absorbed energy, D, is chosen as a parameter then the energy action coefficient  $\mu$  must be introduced to convert dose to concentration. This necessitates the 'hit' be re-defined as the mean amount of energy required to produce the response. The energy action coefficient is thus a measure of the efficiency of the utilisation of energy or the reciprocal of the mean energy per inactivation. Equation (1) is rewritten as

$$P_1 = e^{-v \cdot \mu \cdot D} \text{-----(2)}$$

$\mu$  is rarely written explicitly because it is usually taken (erroneously) as a constant of proportionality.

If the natural logarithm of the survival probability is plotted against absorbed dose,  $D$ , a straight line of gradient  $-\mu$  is obtained. Typical results for various radiations in ribonuclease (2) show that the gradient (and hence  $\mu$ ) decreases with increasing LET due to (i) energy wastage by saturation but this is counteracted to some extent by (ii) more efficient spatial use of energy by the  $\beta$ -rays and (iii) possible increased efficiency associated with the chemical action of the physical interaction products.

As an alternative to using  $v$ ,  $\mu$ , and  $D$  as parameters one may use the effect cross-section  $\sigma_H$  and the radiation fluence  $\phi$ . For track segment experiments  $\sigma = D/L$  and

$$\therefore \sigma_H = v \cdot \mu \cdot L \text{ -----(3)}$$

Originally it was thought that as  $L$  increased,  $\sigma_H$  would tend towards  $\sigma_g$  the geometric cross-section but experiment showed that  $\sigma_H$  may be many times the geometric cross-section due, at least in part, to the spatial distribution of the  $\beta$ -rays associated with high LET radiations. Here, the spatial effect is included within the detailed formulation of  $\mu$ .

#### Energy absorption processes for slow ions.

Experimental data (3) for proton and heavier ion inactivation of enzymes indicates that elastic scatter interactions are for equal energy deposition much more efficient at producing damage than are simple ionising collisions. Hence, allowance ought to be made for the partition of energy into protons associated with each type of energy absorption process.

A modified target model has been proposed (4) which takes into account the following important factors: direct primary, secondary and subsequent interactions; the (indirect) chemical action of the slowed down products; the spatial distribution of the secondary particles released in the direct interactions; event or energy wastage due to saturation (overkill) in the targets; different damage efficiency for different types of interaction process.

#### Modified Target Model (single target, single hit).

Let  $\bar{N}_p$  be the mean number ( $m$ ) of interactions produced in a primary target.  $\bar{N}_p$  is limited to a maximum of unity to allow for saturation by use of the Poisson probability  $P(m)$ . Let  $\bar{n}$  be the number of secondary targets inactivated by a secondary particle assumed to have the mean energy of the secondary particle spectrum. If the target has a geometric cross-section  $\sigma_g$  then the total hit cross-section for a radiation of type  $i$  is

$${}^i\sigma_H(E) = {}^i\sigma_{H,p}(E) + {}^i\sigma_{H,s}(E) + CC \text{ -----(4)}$$

where the primary contribution  ${}^i\sigma_{H,p}(k) = \sigma_g \cdot P_-(m)$

the secondary contribution  ${}^i\sigma_{H,s}(k) = \sigma_g \cdot {}^iN_p \cdot \bar{n}$

and the chemical contribution  $CC = \sigma_g \left\{ \bar{\epsilon}_j {}^iN_p + {}^iN_p \sum_{k=1}^n (\bar{\epsilon}_k {}^iN_k) \right\}$

( $\bar{\epsilon}_j$  and  $\bar{\epsilon}_k$  are respectively the mean chemical action efficiencies for the primary  $j$  and secondary  $k$  particles).

Better appreciation of the significance of the formula may be obtained by examining a simplified version appropriate to low LET radiation.

#### Simplified Cross-Section. ( $d \ll \lambda$ )

If the mean free path  $\lambda$  between interactions is very much greater than the mean chord length  $d$  through the target i.e. valid for fast charged particles of low LET then  $\bar{\epsilon}_j \sim \bar{\epsilon}_k = \epsilon$  and  $P_-(m) \approx {}^iN_p$ . then

$${}^i\sigma_H(k) = \sigma_g \cdot {}^iN_p (1 + \bar{n})(1 + \epsilon) \text{-----}(5)$$

or in alternative form using the target volume  $v$  and macroscopic cross-section  ${}^i\Sigma_p$

$${}^i\sigma_H(k) = v \cdot {}^i\Sigma_p \cdot (1 + \bar{n})(1 + \epsilon) \text{-----}(6)$$

#### Dosimetry parameters.

1) The absolute value of the bimolecular (biological) effectiveness in a fluence  $\sigma_1$  of radiation type 1 is given by the damage parameter

$${}^i\sigma_H \cdot \sigma_1 = (1 + \epsilon) \cdot v \cdot C \text{-----}(?)$$

Thus the original survival probability  $e^{-vC}$  becomes  $e^{-(1 + \epsilon) \cdot v \cdot C}$ . Note that the RBE is given simply by the ratio of the effect cross-sections.

2) The additive parameter (of dose equivalent,  $H$ ) for different radiations  $i$  is  ${}^i\sigma_H \cdot \sigma_i$ .

3) The radiation quality is defined by the parameters  $(1 + \epsilon)(1 + \tilde{R}) \cdot \sum_p$  and  $v$ . Note that the biological and physical parameters are not separable because of the existence of  $\tilde{R}$  and possibly  $\epsilon$ .

4) The energy action coefficient  $\mu$  can be expressed in terms of the fundamental interactions by

$$\mu = \frac{(1 + \epsilon)(1 + \tilde{R}) \cdot \sum_p}{L} \text{-----(8)}$$

Fig. 1 shows the reciprocal of  $\mu$  for H, He and N ions incident on ribonuclease where it will be seen that  $\mu$  is not constant. This energy region is of practical relevance to intermediate energy neutron dosimetry.

5) For single hit action the survival probability should be written as

$$e^{-v \cdot \sum_r \mu_r \cdot D_r} \text{-----(9)}$$

where  $D_r$  is the partition of the total absorbed dose expended in process type  $r$  or as  $e^{-\sum_i \mu_i \cdot D_i}$  where  $i$  denotes the radiation type

Examination of equation (7) suggests that if values of  $\epsilon$  can be deduced for different target groups e.g. enzymes, viruses, cells etc. then measurement of the concentration of events (e.g. free electrons, free H atoms, etc.) combined with a knowledge of the geometric volume of the target may permit construction of a new system of dosimetry without need for the energy parameters required in the more conventional approach (cf. equations 8 and 9).

The experimental aspects of this work were performed under Euratom grant 184-76 BIO-WX.

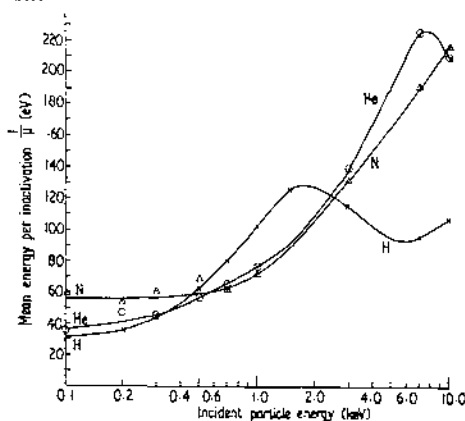

Fig. 1. Mean energy per inactivation of a ribonuclease molecule for H, He and N projectiles. On the left side of the maxima damage is primarily due to elastic scattering and on the right side to ionisation.

### References

- 1) Lea, D.E., 1946, Actions of Radiation on Living Cells (Camb. Univ. Press).
- 2) Marshall, M., Holt, H.S., Gibson, J.A.B., 1970, *Int. J. Radiat. Biol.* 18, (2), 139-146.
- 3) Watt, D.E. and Stenliffe, E.F., 1975, *Phys. Med. Biol.*, 20, 326-343.
- 4) Watt, D.E., 1975, *Phys. Med. Biol.*, 20, 944-954.

DONNEES RECENTES SUR LES VALEURS DE  $\bar{W}$ ,  
ENERGIE MOYENNE CORRESPONDANT A LA CREATION D'UNE PAIRE D'IONS

E. Lavigne\*, M. Chemtob\*, J. Chary\*, J.P. Noël\*\*

### 1. INTRODUCTION

Des recherches expérimentales récentes se sont appliquées à l'étude des variations de  $\bar{W}$  (énergie correspondant à la création d'une paire d'ions) avec l'énergie et la masse de la particule chargée incidente. Les valeurs de  $\bar{W}$  augmentent lorsque la vitesse initiale des particules incidentes est inférieure à la vitesse de l'électron dans la première orbite de BOHR de l'atome d'hydrogène ( $V_0 = e^2/h$ ). Cette augmentation a été attribuée, en partie, à la contribution dans la perte d'énergie des processus de diffusion élastique et des processus de capture électronique. Aux énergies incidentes plus élevées, ces processus deviennent négligeables, comparés aux phénomènes d'ionisation et d'excitation, et les valeurs de  $\bar{W}$  varient peu avec l'énergie de la particule incidente.

La plupart des informations expérimentales disponibles ont été obtenues dans les gaz argon, méthane, acétylène et éthylène dans un domaine d'énergie supérieure à 1 MeV. La variation de  $\bar{W}$  et la quantité d'énergie déposée par des processus autres que l'ionisation et l'excitation dans les matériaux équivalents aux tissus présentent un intérêt particulier dans la dosimétrie des neutrons, ainsi que dans l'interprétation des effets biologiques des particules secondaires (H, C, N, O) créées dans les tissus. Ce travail donne des informations sur l'ionisation du gaz équivalent-tissus ( $\text{CH}_4$  : 61,4%,  $\text{CO}_2$  : 32,4%,  $\text{N}_2$  : 3,2%) par les ions H, C, N, O et  $\text{He}^+$  d'énergie comprise entre 25 et 500 keV. Des valeurs de  $\bar{W}$  ont été également mesurées pour des particules alpha d'une source d'américium ( $E_\alpha = 5,47$  MeV) dans différents gaz et sont comparées aux valeurs déjà existantes dans la littérature.

### 2. METHODE EXPERIMENTALE

L'appareillage expérimental et la méthode sont similaires à ceux utilisés par LOWRY et MILLER (1) et plus récemment par BORING, PHIPPS et WOOD (2). Le faisceau d'ions incident est issu d'un accélérateur SAMES de 600 kV dont la tension d'accélération a été initialement étalonnée à partir de la résonance à 334 keV de la réaction  $^{19}\text{F}(p,\alpha\gamma)\text{O}^{16}$ . Les ions sont analysés par déflexion électromagnétique. La valeur du champ magnétique est mesurée par une sonde à effet Hall. Sa valeur a été trouvée à  $\pm 0,5\%$  proportionnelle à la racine carrée de l'énergie et à la masse de l'ion considéré.

Les ions pénètrent dans la chambre par un diaphragme formé de deux collimateurs - Le premier est constitué d'un trou de 0,1 mm de diamètre percé dans du rubis, - Le second est un trou de 0,16 mm de diamètre percé dans le même matériau. Il permet de réduire la quantité d'ions diffusés dans la chambre. Une pompe à diffusion, munie d'un piège à azote liquide, maintient à l'entrée de la chambre une pression approximative de  $10^{-5}$  torr. La chambre peut opérer dans ces conditions à des pressions inférieures à 20 torr.

\* Département de Protection - Service de Protection Sanitaire  
Commissariat à l'Energie Atomique - BP n° 6 92260 FONTENAY AUX ROSES

\*\* Département des Etudes Mécaniques et Thermiques - Laboratoire des Transferts Thermiques & Mécaniques des Fluides - Commissariat à l'Energie Atomique - BP n° 2 91190 GIF SUR YVETTE.

La quantité d'ions diffusés à l'intérieur de la chambre a été systématiquement évaluée par la mesure du spectre énergétique des particules incidentes. La perte d'ionisation dans le diaphragme a été également examinée en faisant varier la pression à l'intérieur de la chambre. Pour des pressions envisagées de 7 à 15 torr, l'ionisation mesurée a été trouvée identique aux incertitudes expérimentales près. Il a été conclu que la perte d'ionisation dans le diaphragme pouvait être négligée.

La chambre elle-même comprend :

- une électrode interne en acier inoxydable de 3 mm de diamètre, 940 mm de longueur, terminée à son extrémité par une sphère de 6 mm de diamètre ;
- une électrode externe constituée d'un cylindre en acier de 220 mm de diamètre interne et d'une longueur totale de 1,029 m. Le volume est rempli soit avec du gaz argon, soit avec du gaz T.E. ;
- une enveloppe, maintenue au potentiel zéro et isolée de l'électrode externe par des bagues isolantes en téflon. C'est un cylindre de 250 mm de diamètre interne et d'une longueur totale de 1,093 m.

La chambre opère alternativement, - en chambre d'ionisation pour mesurer le courant d'ionisation, - en compteur proportionnel pour déterminer le nombre de particules incidentes. Une alternance de ces modes de fonctionnement est nécessaire pour réduire les effets sur les mesures des fluctuations de l'intensité du faisceau primaire.

### 3. CARACTERISTIQUES DE LA CHAMBRE D'IONISATION

Les ions positifs produits dans la chambre sont collectés sur l'électrode interne, polarisée négativement. Le courant collecté est appliqué à un amplificateur de charge dont la sortie est connectée sur un convertisseur tension-fréquence (10 V/10 kHz). La résistance de réaction de cet amplificateur ( $R = 5 \cdot 10^{-1} \Omega$ ) a été mesurée avec précision ( $\pm 0,5\%$ ) par un générateur de courant. La constante de temps appliquée est de 1,5 s.

Les signaux du convertisseur sont comptés pendant une période de 10 s sur une échelle de comptage. Le nombre d'ionisations  $N$  créées dans le volume gazeux est alors déduit du nombre de coups enregistrés par la relation :

$$N = Q/e = \frac{10^{-3}}{e} \cdot \frac{q}{R} = 1,25 \times 10^4 \times q$$

où :  $Q$  est la charge collectée exprimée en coulombs,

la constante  $10^{-3}$  est exprimée en V.s par unité de coup

$R$  est la résistance exprimée en ohms

$q$  est le nombre de coups enregistrés sur l'échelle pendant 10 s

$e$  est la charge de l'électron exprimée en coulombs.

La courbe caractéristique de fonctionnement de la chambre (courant en fonction de la tension appliquée) a été tracée à une pression de 10 torr pour le gaz argon. Elle est présentée dans la référence (3) : le courant d'ionisation atteint sa valeur de saturation pour une tension comprise entre 0 et +600 V. Lorsqu'une polarité négative est appliquée, la multiplication électronique a lieu au-delà d'une tension de -300 V.

### 4. CARACTERISTIQUES DU COMPTEUR PROPORTIONNEL

Les impulsions recueillies sur l'électrode interne, polarisée positivement, sont appliquées à l'entrée d'un préamplificateur de charge (ORTEC 109 PC). La sortie du préamplificateur est connectée sur un amplificateur linéaire (ORTEC 452) qui met en forme les impulsions. Celles-ci entrent soit dans un sélecteur d'amplitudes (ORTEC 420 A), permettant d'éliminer le bruit de fond, puis sur une échelle de comptage, soit sur un analyseur d'amplitudes.



Avec un gain affiché de 100 et des constantes de temps de différentiation et d'intégration de 2  $\mu$ s, la résolution électronique de la chaîne, mesurée sur l'analyseur à partir d'un générateur d'impulsions, est de l'ordre de 6%. Les distributions d'amplitudes obtenues sont proches d'une courbe de Gauss; leur largeur à mi-hauteur varie de 8 % à 36 % suivant la masse et l'énergie de l'ion accéléré. Si p est le nombre de particules qui entrent dans la chambre durant une période de 10 s, l'énergie totale perdue  $\mathcal{E}$  est donnée (en eV) par :

$$\mathcal{E} = p \cdot E \cdot 10^3$$

où E est l'énergie de la particule incidente en keV.

### 5. CALCUL DE $\bar{W}$

La valeur de  $\bar{W}$  (en eV) pour l'ion considéré est calculée par la relation suivante :

$$\bar{W} = \frac{\mathcal{E}}{N} = 8 \cdot 10^{-2} \times \frac{p}{q} \times E$$

### 6. RESULTATS

Le tableau 1 donne les valeurs de  $\bar{W}$  obtenues dans différents gaz lorsque les particules  $\alpha$  sont issues d'une source d'américium. Ces valeurs s'accordent avec celles des auteurs mentionnés. Les valeurs de  $\bar{W}$  relatives au gaz T.E., pour les différentes particules (H, C, N, O, He) sont portées dans le tableau 2. Peu de données ont été publiées dans la littérature, seulement deux valeurs peuvent être comparées. Pour des ions  $H^+$  de 48 keV, la référence 4 donne  $\bar{W} = 30,40$  eV et pour des ions  $O^+$  de 49 keV,  $\bar{W} = 52,2$  eV. Ces données s'accordent à 1,5 % près à nos valeurs relatives à 50 keV.

Gaz	$\bar{W}$ (eV) ce travail	$\bar{W}$ (eV) autres auteurs
Ar	26,25 $\pm$ 0,16	26,4 $\pm$ 0,3 (a)
N <sub>2</sub>	35,73 $\pm$ 0,3	36,3 $\pm$ 0,4 (a)
		36,36 $\pm$ 0,07 (b)
CO <sub>2</sub>	35,23 $\pm$ 0,21	34,3 $\pm$ 0,3 (a)
		34,4 $\pm$ 0,1 (c)
Gaz T.E.	31,44 $\pm$ 0,25	$\bar{w} = 31,3$ (d)

(a) BORTNER et HURST (1954)

(b) BAY, NEWMAN (1961)

(c) WHYTE (1963)

(d) BCOZ et coll. (1972)

TABLEAU 1 Comparaison des valeurs de  $\bar{W}$  pour des ions  $He^{++}$  ( $E_{\alpha} = 5,47$  MeV)

Energie de l'ion incident (keV)	$\bar{W}$ (eV) - Gaz T.E.				
	$H^+$	$He^+$	$C^+$	$N^+$	$O^+$
25	$29,13 \pm 0,52$	$33,55 \pm 1,15$			
50	$30,82 \pm 0,68$	$33,34 \pm 1,0$	$42,43 \pm 0,86$	$43,68 \pm 1,25$	$51,45 \pm 0,95$
100	$29,65 \pm 0,54$	$33,13 \pm 0,96$	$40,35 \pm 0,90$	$42,72 \pm 0,66$	$48,69 \pm 0,77$
150	$29,70 \pm 0,94$	$35,63 \pm 0,81$	$40,58 \pm 0,72$	$42,05 \pm 0,66$	$46,60 \pm 0,93$
200	$31,82 \pm 0,95$	$33,59 \pm 1,0$	$39,71 \pm 1,07$	$40,21 \pm 1,06$	$44,36 \pm 1,06$
300	$32,13 \pm 0,6$	$33,93 \pm 0,97$	$39,71 \pm 0,75$	$40,29 \pm 0,72$	$43,77 \pm 0,68$
500		$35,09 \pm 0,96$	$39,15 \pm 0,69$	$40,49 \pm 1,15$	$42,59 \pm 0,76$

CARTEAU 2 Valeurs de  $\bar{W}$  pour  $H^+$ ,  $He^+$ ,  $C^+$ ,  $N^+$ ,  $O^+$  dans le gaz T.E.

#### REFERENCES

- (1) LOWRY, R.A., MILLER, G.H., Phys. Rev., 109, 826 (1958).
- (2) BORING, J.W., PHIPPS, J.A., R.A., (1964) Phys. Rev. 132, A 36
- (3) CHEMTOB, M., LAVIGNE, B., CHARY C., NGUYEN, V.D., PARMENTIER, N., Some experimental results on  $\bar{W}$  values for heavy particles, Phys. Med. Biol. (1977) (à paraître).
- (4) LEONARD, B.E., BORING, J.W., (1973) Radiat. Res., 52, 1.

MEASURES OF  $\gamma$ -DOSES AND GASEOUS DISPERSION FACTORS IN  
THE ENVIRONMENT OF A NUCLEAR FACILITY IN A TYPICAL  
MIDDLE-EUROPEAN SITE

E. NAGEL  
Federal Institute for  
Reactor Research  
CH-5303 Würenlingen

F. CHAKRABORTY  
Nuclear Safety  
Division  
CH-5303 Würenlingen

1. In the trajectories of the main wind directions at critical locations (e.g. villages) in the environment of the nuclear facility in Würenlingen (EIR) the  $\gamma$ -radiation level has been continuously measured with very sensitive G.-M. detectors. During a whole year (Dec. 1975 - Nov. 1976) the results have also been registered graphically on appropriate recorders, thus allowing to determine simultaneously the local dose rates and their variations which is not possible with the also existing TLD (CaF<sub>2</sub>:Dy) surveillance system. The network has been completed if necessary with a high pressure ionisation chamber (RSS-111). It will be also possible to calculate the dispersion factors of the plume emitted by the heavy water reactor of the EIR which releases about 14-16 mCi Ar-41/sec into the atmosphere through a stack of 70m height.

The detectors have been installed at 1,7 to 5 km from the Ar-41 source, so it was possible to consider the dispersion of the plume almost during weather conditions with adiabatic lapse rate when the plume reaches the ground not too far from the stack.

In this paper only a few aspects have been considered such as to compare some results of these measurements with figures calculated with a computer program in order to test their validity in this region where relatively broad valleys alternate with hills of mean altitude (200-300 m above ground) as they are typical for all actual sites of nuclear plants in Switzerland and for many of them in Central Europe.

The investigations were restricted to short-term emissions (i.e. 1 hour) during atmospheric conditions of adiabatic lapse rate. More detailed results and long term diffusion calculations will be reported when the measures of the whole period will have been considered.

2. For a long term diffusion calculation such as annual dose calculations from the atmospheric emissions of radionuclides from a nuclear power plant the good agreement between measurement and calculation has been reported by J.A. Martin Jr. (ANS 20th Annual Meeting, 1974). The purpose of this experiment was to verify the short-term diffusion model through the measurement of  $\gamma$ -dose rates from the Ar-41 emissions.

The computer code AIREM is used to calculate the atmospheric dispersion and diffusion. AIREM is based on sector averaged diffusion equation for long-term average calculations.

The same code is used here for a short-term diffusion calculation considering the dispersion of the plume in a single 22,5° sector. The cloud  $\gamma$ -

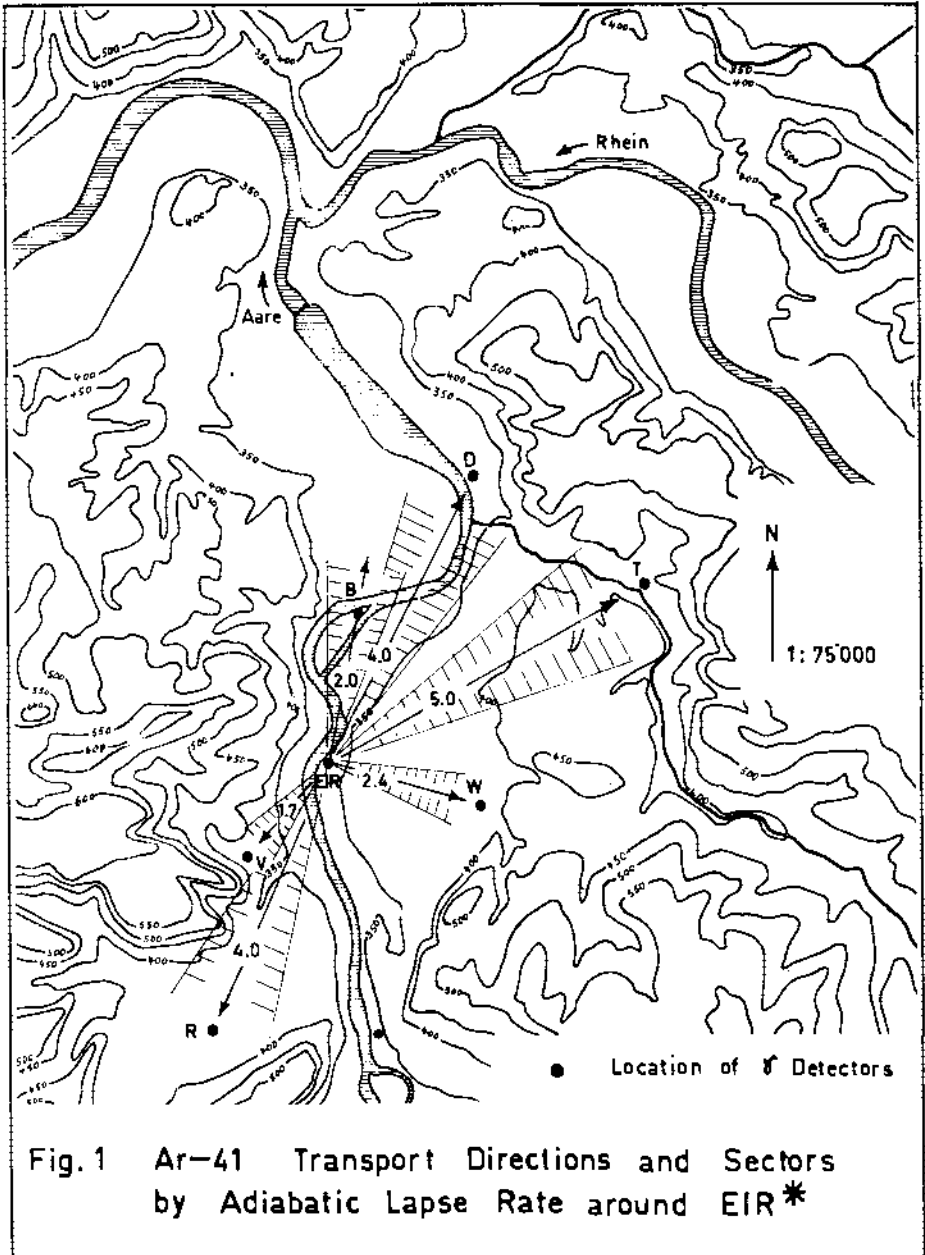

\* S-SW, NNE-NE and WSW-WNW are the main wind directions during such atmospheric conditions.

dose rates were calculated using a model that considers the finite extent of the cloud, all decay  $\gamma$ -energies and dose buildup factors (computer code EGAD).

The ratios of the calculated to the measured dose rates at various points are shown in the following table :

Table 1 Ratios of calculated to measured dose rates ( $\mu\text{rem}/\text{hour}$ ) in the environment of EIR for short-term emissions and during adiabatic lapse rate.						
$\bar{u}$ m/sec	Point V 1,7 km	Point B 2 km	Point W 2,5 km	Point D 4 km	Point R 4 km	Point T 5 km
1,5 - 3,0	$\frac{47}{4} = 12$ $\frac{40}{14} = 2,8$ $\frac{34}{1} = 34$ $\frac{32}{1} = 32$	$\frac{48}{17} = 2,8$ $\frac{36}{21} = 1,7$ $\frac{36}{7} = 5,1$ $\frac{32}{10} = 3,2$ $\frac{29}{7} = 4,1$	$\frac{29}{2} = 14,5$ $\frac{30}{3} = 10$	$\frac{18}{2} = 9$ $\frac{16}{2} = 8$ $\frac{15}{2} = 7,5$ $\frac{14}{3} = 4,7$	$\frac{23}{5} = 4,6$ $\frac{20}{12} = 1,6$ $\frac{17}{4} = 4,2$ $\frac{16}{10} = 1,6$ $\frac{15}{8} = 1,9$	$\frac{12}{2} = 6$ $\frac{12}{1} = 12$
> 3,0 - 4,5	$\frac{23}{3} = 7$ $\frac{20}{2} = 10$ $\frac{19}{2} = 9,5$	$\frac{27}{12} = 2,2$ $\frac{27}{7} = 3,8$	$\frac{15}{4} = 3,7$	$\frac{13}{2} = 6,5$		$\frac{10}{1} = 10$ $\frac{8,5}{1} = 8,5$
> 4,5 - 7,5	$\frac{19}{3} = 6,3$ $\frac{19}{2} = 9,5$ $\frac{21}{3} = 7$	$\frac{16}{4} = 4$	$\frac{11}{1} = 11$	$\frac{8}{1} = 8$		$\frac{9}{1} = 9$ $\frac{6}{1} = 6$

For calculations the diffusion factor has been adapted to the effective height of release depending on prevailing wind velocities. The roughness of the ground has not been taken into account.

The figures in table 1 show that all calculated dose rates are higher than the measured ones. But the figures are not homogeneous.

If compared with the map of Fig.1 it is obvious that the best results (with in a factor 2 - 4) would be obtained at locations situated in a quasi flat country as it is the case for point R in SSW and point B in N. Increasing factors (till a factor of 10) were calculated at locations where the plume rose in front of hills of 150 - 200m elevation e.g. Point V (NE-winds) W (WVW-winds), D (SSW-winds) or crossed a small valley (W, WSW-winds) these

ground it only partly reached. Such plumes are known to overflow ridges quite directly during weather conditions of adiabatic lapse rate as those chosen for these calculations.

3. Due to the differences between the calculated and measured dose rates as shown in table 1, the short term diffusion factors to be used in the code should be reduced accordingly.

For heights of release from 80 to 100 m as considered in this paper and for conditions as existing in the Points B (2 km) and R (4 km) values ranging between  $2 \cdot 10^{-7}$  and  $5 \cdot 10^{-7}$  sec/m<sup>3</sup> could be considered as reasonable.

4. A first approach shows a good agreement between the use of the model and the measurements (within a factor 2 - 4 in appropriate cases) and promises that the code AIREM can be used also for short-term diffusion calculations.

RADIOACTIVE PLUMES

G. D. Kaiser

UKAEA Safety and Reliability Directorate,  
Wigshaw Lane, Culcheth, Warrington, UK.

## 1. INTRODUCTION

## THE IMPORTANCE OF PLUME RISE

Gaseous effluent released from a nuclear reactor may rise for several reasons. (i) It may be hot - the Rasmussen Report (1) shows that, in the category of accident designated PWR1, the rate of release of heat can be as high as 200 MW. (ii) The plume will be self-heating, that is,  $\alpha$ -,  $\beta$ - and  $\gamma$ -rays emitted by radioactive material will heat it. (iii) The plume may have a high water content - this is plausible if LHR's are being considered - and, as it rises, condensation of water vapour may release latent heat. (iv) At first, the plume may have a high velocity in any direction - imagine, for example, that it emerges from a small hole in a pressurized container. Any or all of these effects could cause the plume to rise and, if a convincing study of the safety of a reactor system is to be made, it is necessary to examine the effect that the rise has on the airborne concentration of effluent at various distances downwind.

## 2. THE CALCULATION OF PLUME RISE

There are a great number of plume rise models (2). The one used in this paper is that of Gifford (3) which has been incorporated into the Safety and Reliability Directorate computer program TIRION (4) the purpose of which is to examine the consequences of releasing radioactive material to the atmosphere. Gifford's model, however, has been modified to take account of the ways in which plume rise can be terminated, see Sect. 4.

## 3. GROUND LEVEL CONCENTRATIONS UNDERNEATH A RISING PLUME

For the profile of pollutant concentration across a plume, many authors assume a 'top-hat' distribution, that is, a uniform concentration from the centre out to a well defined radius, at which there is a sharp cut-off. Others assume a Gaussian profile, as is the case with TIRION. The implication of this is that ground level concentrations under a rising plume are very small.

That this is plausible is very clear from a demonstration witnessed by the author (5). Salt water was allowed to fall into a tank of less dense tap water through a vertical tube that was simultaneously moving horizontally. This experiment simulates the release of buoyant gas into moving air. As the salt water plume fell downwards it remained a clearly visible and distinct entity, so much so that wisps of salt water that momentarily attempted to escape from the plume were drawn back in again at once. It was thus demonstrated that, during the early development of the plume, ambient fluid was entrained by the action of plume generated turbulence and that the material of the plume itself was not drawn into the surrounding fluid.

It is this aspect of plume rise that is important from the point of view of reactor safety studies. So long as the plume continues to rise, airborne concentrations of radioactive material at ground level beneath it can be assumed to be small. The consequence is that inhaled doses and contamination of the ground by  $\alpha$ - or  $\gamma$ -emitters are also small.

#### 4. TERMINATION OF PLUME RISE

Since the calculation of ground level airborne concentrations is all important in reactor safety studies, it is necessary to identify the ways in which plume rise can be terminated so that the action of mechanical or convective atmospheric turbulence can bring radioactive material back down to the ground.

##### 4.1 Stable Weather Conditions

If there is a temperature inversion in the atmosphere, the difference in temperature between the plume (which is assumed to expand adiabatically) and its surroundings decreases as rise occurs until there is no resultant upward force on it. This is used as a criterion for determining the final height of rise although strictly there may be 'overshoot' followed by 'fall-back' to a final height of rise, or even a number of damped oscillations. These are ignored for the sake of simplicity. If the plume is vigorously self-heating, however, the above decay of buoyancy may be more than compensated for; the rise will continue indefinitely.

##### 4.2 Overhead Inversions

Even when the conditions near the ground correspond to neutral or unstable conditions, the atmospheric boundary layer is usually capped by an inversion at a height of a few hundred metres into which the plume may rise and so be brought to a halt. A conservative assumption for dealing with this problem is to terminate plume rise when the upper edge of the plume reaches the inversion.

##### 4.3 The Action of Turbulence

When there is no inversion to bring plume rise to a halt, the plume may cease to behave as the distinct entity described in Sect. 3 when the 'vigour' of atmospheric and plume generated turbulence becomes comparable. The height at which this occurs may be calculated by equating the turbulence dissipation rates, for which Briggs gives expressions (2), within and outside the plume. Briggs argues that, once the 'vigour' of atmospheric turbulence equals that within the plume, rapid 'breakup' will occur and the rise should be assumed to have terminated.

##### 4.4 Meander

In convective conditions, the mixing layer consists of upward thermals carrying heated air from the ground and of compensating downdrafts. This accounts for the plume 'looping' or meandering phenomenon. If the typical upward and downward convective velocities exceed the expected rate of rise of the plume it can be assumed that breakup will occur.

##### 4.5 Lift-off

There is the possibility that a plume emitted into a reactor building wake will not lift off the ground. (b) Briggs has given a speculative prescription for determining whether such a plume will rise or not.

#### 5. GROUND LEVEL CONCENTRATIONS AFTER TERMINATION OF PLUME RISE

This is simply calculated. Assume that the plume behaves as a continuous area source centred on the height of rise at termination. The radius of



this source is calculated from the standard plume rise formulae described in Sect. 2. The radially symmetric concentration profile across the source may be 'top-hat' or, for ease of computation, Gaussian with the radius defining the 10% concentration contour - this is how TIRION works. Concentration profiles further downwind are calculated by using a conventional Gaussian dispersion model. Similarly, if plume rise is prevented by the building wake effect, the downwind concentration profiles can be calculated by assuming that the plume trapped in the wake forms another area source which should be fed into the atmospheric dispersion model.

## 6. RESULTS OF CALCULATIONS PERFORMED USING TIRION

It can be seen from the foregoing that the treatment of plume rise, even when simplified as described, depends upon a large number of parameters. A thorough analysis of all these effects is beyond the scope of a short paper such as this. It has been decided to concentrate on the following examples of how the above mechanisms affect ground level concentrations: a total of 1 Ci of a very long lived fission product is emitted over a period of some thirty minutes in company with heat at a rate of 100 MW. The reactor building wake is assumed to be 50 m high by 100 m wide and to persist for five building heights downwind. The deposition velocity is assumed to be 0.003 m/s.

### 6.1 Class D, Windspeed 6 m/s

Results for this weather condition are given on Fig. 1(a). A non-buoyant plume released from a point source gives concentrations described by curve (1,2,3) while emission into the building wake gives curve (2,3,4). Uninterrupted plume rise from a point source at ground level gives curve (1,2,5) while if plume rise is terminated (in this case by contact with an inversion lid 1000 m above ground level) curve (1,2,6) results. Uninterrupted plume rise after emission into the building wake is described by curve (2,4,5). Lift-off occurs with plenty to spare but if the rate at which heat were emitted from the plume were only 1-10 Megawatts, Briggs' prescription (6) suggests that lift-off might not occur. Curve (2,4,6) shows what happens when the plume rise is terminated, in this case also by contact with the inversion lid. The lesson to be learned from this is as follows. Plume rise, even when self heating is neglected, can be important when heat is released at a high but plausible rate (1); however, use of the naive plume rise model, curve (1,2,5) can give misleading results. Both the initial mixing with the building wake and subsequent termination of plume rise are very important since both mechanisms (mixing with the wake and the breakup effect) act so as to increase the concentrations calculated by using the unlimited plume rise model; this is characteristic of all of the mechanisms that act so as to inhibit or terminate plume rise.

### 6.2 Class F, $u = 2$ m/s : atmospheric inversion

As before, curves (1,2,3) and (2,3,4) of Fig. (1b) show what happens to a non-buoyant plume without and with a wake effect respectively. Plume rise from a point source, curve (1,2,6) or from the building wake, curve (2,4,6) with subsequent termination of rise by decay of buoyancy confirm the statements already made that plume rise effects cannot be neglected. In addition, curve (1,2,6) shows that calculated airborne concentrations at large distances can actually be higher with plume rise than without. This is because, with a buoyant plume, there is much less depletion of airborne activity by deposition than for the non-buoyant release.

7. CONCLUSION

The effect of plume rise, together with mechanisms for plume rise termination, cannot be neglected if the release of radioactive effluent to the atmosphere is accompanied by much heat.

REFERENCES

- (1) Reactor Safety Study, WASH 1400 (1975)
- (2) BRIGGS, G. A., "Plume Rise Predictions" ATDL Contribution File 75/15 (1975).
- (3) GIFFORD F. A., "The Rise of Strongly Radioactive Plumes" J. Appl. Meteor 6 (1967)644.
- (4) KAIBER G. D., SRD report R63 (1976).
- (5) TURNER J. S., Private Demonstration, Cambridge (1975).
- (6) BRIGGS, G. A. "Lift-off of Buoyant Gas Initially on the Ground", ATDL Contribution File No.87 (Draft) 1973.

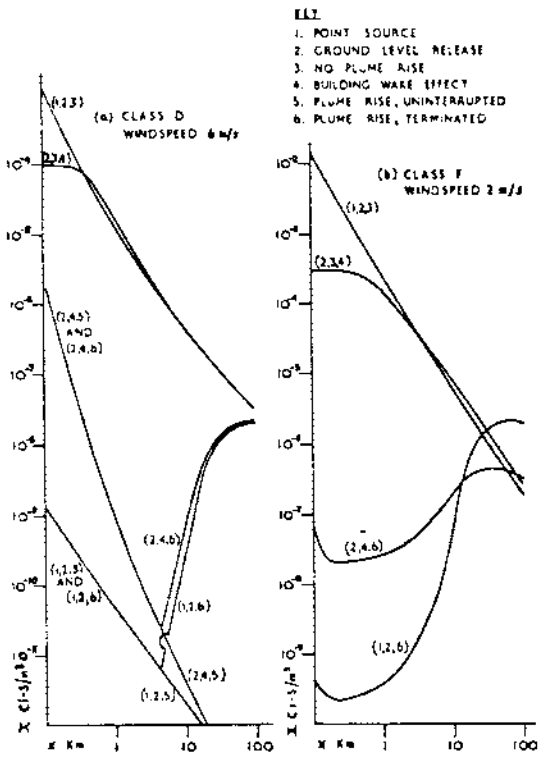

**Fig. 1** Downwind Centre - Line Concentrations ( $Ci\text{-sec}/m^3$ ) as a Function of Distance from the Source (Km)

INDIVIDUAL AND COLLECTIVE DOSES DUE TO  $^{41}\text{Ar}$  BASED ON  
MEASURED DISCHARGE RATES FROM CEBG REACTORS

R. H. Clarke and R. Wilson

Central Electricity Generating Board, Berkeley Nuclear Laboratories,  
Berkeley, Gloucestershire, U.K.

ABSTRACT

Shield cooling air from early Magnox Reactors contains quantities of  $^{41}\text{Ar}$ , a short-lived  $\gamma$ -emitter whose elevated release gives a finite exposure at the site boundaries. A series of experimental measurements has established the discharge rates of  $^{41}\text{Ar}$  from the early CEBG reactors and the results have been used to estimate individual and collective doses around each site.

1. INTRODUCTION

In the early CEBG Magnox Reactors, which utilise steel pressure vessels, shield cooling air passes between the outside of the pressure vessel and the biological shield before being discharged to atmosphere. The stable isotope  $^{40}\text{Ar}$  in that air becomes activated by neutron capture and the  $^{41}\text{Ar}$  formed has a half-life of 1.83 hours and emits a 1.293MeV  $\gamma$ -ray in 99.2% of its decays. Because of the long mean free path of  $\gamma$ -rays in air, there are low, but not insignificant, dose rates at the site boundary. Measurements of  $^{41}\text{Ar}$  discharge rates are not made routinely although one or two estimates have been given (1). In this paper, results are presented from experimental determinations of these discharge rates together with estimates of individual and collective dose distributions for each site.

2. EXPERIMENTAL MEASUREMENTS

Air samples were drawn from the shield cooling circuit at each station into a cylindrical vessel 200mm in diameter and 300mm high. The samples were normally taken at the base of the discharge stack and after the filters to ensure thorough mixing of air from different regions of the shield. After sufficient time to allow complete flushing of the vessel, it was sealed and removed for counting at a convenient location 2 - 8km from, and upwind of, the station to ensure the contribution of the station and the  $^{41}\text{Ar}$  plume to the gamma background was negligible.

The detector consisted of a 75mm x 75mm NaI (Tl) crystal and the vessel located onto the detector head to ensure reproducibility. The system had been previously calibrated to relate activity density in the vessel to count rate in the 1.293MeV  $^{41}\text{Ar}$  photopeak. Pulses from the detector were analysed by a multichannel analyser in 200 channels, each of width 10keV. Natural gamma background was accounted for by accumulating spectra with and without shield cooling air in the vessel and subtracting the background spectrum from the former.

The counts in the photopeak were summed, corrected for decay and the peak totals were related by the calibration factor to the activity density of  $^{41}\text{Ar}$  at the time of collection. The discharge rate of  $^{41}\text{Ar}$  was determined from the measured activity density and the shield cooling air volume flow rate. Table 1 gives the discharge rates at six stations.

The main source of error in the measurements is the uncertainty in the volume flow rate which may be in error by up to 10%. The statistical error in the count rate determinations was normally better than 1%. The

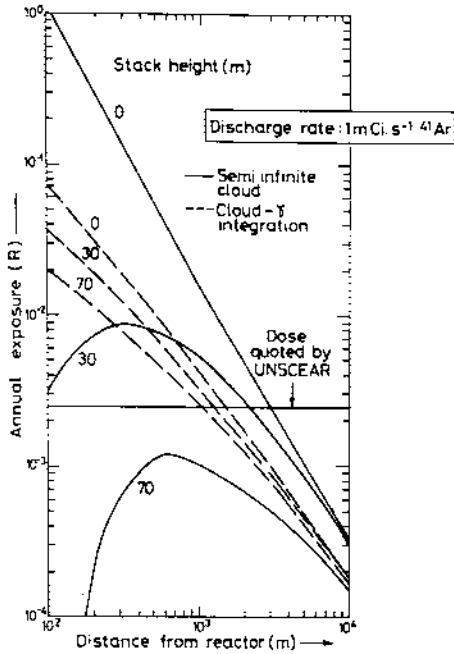

FIG. 1. Annual Cloud- $\gamma$  Exposure for a Release of  $1\text{mCi s}^{-1}$  of  $^{41}\text{Ar}$ , Calculated by the Semi-infinite Cloud Model and by Integration Over the Plume

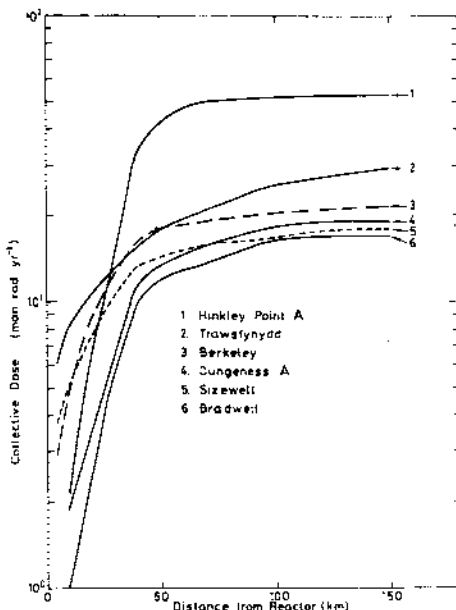

FIG. 2. Collective Dose as a Function of Distance from Reactor (km) from Magnox Sites using Measured Discharge Rates of  $^{41}\text{Ar}$  (Occupancy Screening and Load Factors Allowed)

Site	Reactor 1		Reactor 2		Mean Discharge Rate from Site $1\text{mCi s}^{-1}$
	Reactor Power MW (M)	Discharge Rate $\text{mCi s}^{-1}$	Reactor Power MW (M)	Discharge Rate $\text{mCi s}^{-1}$	
Berkeley	Not Measured $\frac{1}{2}$		118	0.3	0.5
Bradwell	Only Station Figures Available				0.47
Hinkley Point A	690	1.4	526	1.6	2.3
Sizewell	610	0.9	395	1.0	2.0
Dungeness A	730	0.6	749	0.8	1.1
Trawsfynydd	415	2.7	812	1.6	4.6

$\frac{1}{2}$  Corrected for 1978 Station Load Factors  
 $\frac{1}{2}$  Reactor 1 Shut Down at Time of Measurements

Table 1

Measured  $^{41}\text{Ar}$  Discharge Rates and Corresponding Reactor Powers

Site	Frequency of Pasquill Category (%)							Mean Wind Speed $\text{m s}^{-1}$
	A	B	C	D	E	F	G	
Sizewell								
Dungeness	0	0	13	75	4	3	1	5.81
Trawsfynydd								
Bradwell		5	15	55	6	8	2	5.14
Hinkley Pt								
Berkeley	1	5	17	60	1	3	2	4.47
Average UK Smith (4)	0.78	5.23	35.55	54.9	5.90	5.77	2.04	5.10
Byatt (5)	1.7	9.4	36.0	41.0	11.8	26.3	-	2.9

Table 2

Mean Frequencies of Occurrence of Pasquill Weather Categories and Mean Windspeeds Around C.E.S.B. Magnox Sites and Averaged Over the U.K. Smith (4)

Continuous Meteorology Data	Annual Exposure at site Boundary $\text{mR y}^{-1}\text{ per } 1\text{Ci s}^{-1}$		
	100m	200m	400m
Smith (4)	23.3	12.2	6.1
Byatt (5)	37.5	19.2	9.4

Table 3

Annual Cloud- $\gamma$  Exposure for a Discharge Rate of  $1\text{mCi s}^{-1}$   $^{41}\text{Ar}$  from an Effective Stack height of 30m Using Smith (4) and Byatt (5) Data

error in the calibration of the system was estimated to be  $\sim 5\%$ .

The calibration was carried out using a  $1\mu\text{Ci } ^{22}\text{Na}$  point source.  $^{22}\text{Na}$  with a photon of energy  $1.285\text{MeV}$  was used in preference to  $^{41}\text{Ar}$  because of its longer half-life and easier handling. The counts in the photopeak were determined when the source was drawn vertically through the vessel at constant speed, at various radii. The count rate for a uniformly distributed source was then evaluated using numerical integration. Finally, a correction was made for the  $8\text{keV}$  difference between the  $^{22}\text{Na}$  and  $^{41}\text{Ar}$  photon energies.

### 3. INDIVIDUAL DOSES AT THE SITE BOUNDARY

The computer code WEERIE (2) was used to calculate the  $^{41}\text{Ar}$  cloud- $\gamma$  exposure as a function of distance from the release point. The accuracy of the cloud- $\gamma$  integration has been checked (3) against measured  $^{41}\text{Ar}$  exposure rates measured around the early air-cooled graphite moderated reactors BEPO, Windscale and EL2. For the present work, the annual exposures were evaluated per unit release rate of  $^{41}\text{Ar}$  at each site, assuming the mean frequency of occurrence of the 7 Pasquill weather categories and associated windspeeds for a representative area up to about  $100\text{km}$  from each site, which were taken from Meteorological Office Data (4) and are summarised in Table 2. Also shown in Table 2 are the average frequencies of weather categories given by Bryant (5) for the whole of the U.K. and those derived from Smith (4).

Assuming a  $30\text{m}$  effective stack height, the cloud- $\gamma$  exposures at a site boundary  $100$ ,  $200$  or  $400\text{m}$  for a discharge rate of  $1\text{mCi.s}^{-1}$  are shown in Table 3 for a uniform distribution of wind directions and taking Bryant's (5) or Smith's (4) average U.K. continuous release meteorological data. Clearly, Smith's data leads to significantly lower doses, partly due to the use of higher mean windspeeds.

UNSCEAR (6) in its review of radioactivity in the environment, calculated the exposure due to  $^{41}\text{Ar}$  discharges at CEBG Magnox Reactors as  $2.53\text{mR.y}^{-1}$  by using a continuous release dilution factor of  $2.5 \times 10^{-7}$  and the semi-infinite cloud model. In Figure 1 the annual exposure per unit release rate of  $^{41}\text{Ar}$  for a variety of stack heights using the semi-infinite cloud model is compared with WEERIE cloud- $\gamma$  integrations. The total inadequacy of the semi-infinite cloud model at short downwind distances is clear.

### 4. COLLECTIVE DOSE ESTIMATES

Methods of assessing Collective Doses for airborne effluents have been developed based upon integration spatial distribution of Dose over real population density matrices derived from census data (7). For the area around each site a representative table of wind direction frequencies was used to weight the WEERIE cloud- $\gamma$  exposures. Since the WEERIE exposures are for whole body without any allowance for time spent indoors where there is a significant amount of shielding from the plume, an occupancy and screening factor was evaluated using the data of Healy (8). These data give screening factors of approximately  $0.5$  for downstairs in a brick house and  $0.65$  for upstairs. Assuming  $33\%$  of time spent upstairs,  $50\%$  downstairs and  $17\%$  effectively unshielded, an overall screening factor of  $0.63$  was used. Combining these results with those from Table 1, the estimated collective doses from CEBG Magnox Reactors as a function of distance are given in Figure 2.

## 5. CONCLUSIONS

Measured discharge rates of  $^{41}\text{Ar}$  from CEGB Magnox sites are within the range of  $0.5$  to  $4.8\text{mCi.s}^{-1}$ . The calculated individual doses at the site boundaries are in the range  $10$  to  $120\text{mR.yr}^{-1}$ , which is significantly higher than that predicted by UNSCEAR. The associated collective doses have been estimated and range from less than  $20$  to  $53\text{man-rad.yr}^{-1}$ .

## REFERENCES

- (1) Pepper, R. B. and Short, A., 1976, C.E.G.B. Nuclear Power Stations Radioactive Waste Discharges, 1975, NHS/R137/76.
- (2) Clarke, R. H., 1973a, The WEERIE Program for Assessing the Radiological Consequences of Airborne Effluents from Nuclear Installations, Health Physics, 25, pp. 267 - 280.
- (3) Clarke, R. H., 1973b, Physical Aspects of Nuclear Reactors in Working and Public Environments, Ph.D. Thesis, pp. 222 - 225, published by C.E.G.B., Berkeley Nuclear Laboratories, Gloucestershire, U.K.
- (4) Smith, F. B., 1976, A Pasquill Stability Map of the U.K., Private Communication of Meteorological Office Data, Bracknell, Berkshire, U.K.
- (5) Bryant, P. M., 1964, Methods of Estimation of the Dispersion of Wind-borne Material, AHSB(RP)R42.
- (6) UNSCEAR, 1972, Ionising Radiation: Levels and Effects, Vol. 1, Levels, pp. 102 - 105, United Nations, New York.
- (7) Clarke, R. H., Fitzpatrick, J., Goddard, A. J. H. and Henning, M., 1976, The Use of Census Data in Predicting Spatial Distributions of Collective Dose, B.N.E.S. Journal, 15, 4, 297 - 303.
- (8) Healy, J. W., 1968, Radioactive Cloud-Dose Calculations, p. 363 of Meteorology and Atomic Energy, TTD 24190, Ed. Slade, D.H.

## ACKNOWLEDGEMENT

This paper is published by permission of the Central Electricity Generating Board.

ATMOSPHERIC DISPERSION ESTIMATES OF THE GASEOUS  
RADIONUCLIDES FROM THE TAIWAN  
RESEARCH REACTOR

Dong-Pao Chou, Chau-Yuan Lin, Chao-Ming Tsai

Health Physics Division  
Institute of Nuclear Energy Research  
Post Office Box 3-10  
Lung-Tan, Taiwan 325  
Republic of China

## 1. INTRODUCTION

The Taiwan Research Reactor (TRR) is a Canada NRX type reactor, air is used for cooling the reactor structural material such as graphite reflector, thermal shield etc.. The small amount of  $^{40}\text{Ar}$  in air is activated to radio-active  $^{41}\text{Ar}$ , and is released to atmosphere through a 50 meter height stack.

During the reactor was in 40 MW full power operation, by experiment  $^{41}\text{Ar}$  released rate was found to be 3332 curies per day (1). This value is much larger than that of the same type reactor in India (650 Ci/day) (2). The gaseous radioactive effluents from the TRR analysed by Ge(Li) detector was found that the major component was  $^{41}\text{Ar}$ , the other radionuclide was very little. The environmental radiation doses obtained by thermoluminescent dosimeters (TLD's) and environmental monitoring system are contributed by  $^{41}\text{Ar}$  and natural background only. Using environmental radiation doses data,  $^{41}\text{Ar}$  released rate was determined to be 3332 Ci/day (3). The discussion is limited to nuclide of particular important to the TRR, namely  $^{41}\text{Ar}$ .

## 2. CALCULATION AND MEASUREMENT

A computer code (4) is used for the calculation of doses to the general population due to atmospheric emissions of radionuclides. A standard sector-averaged gaussian-diffusion equation is solved repeatedly for each radionuclide, wind sector, stability class and downwind distance. Radionuclide contributions to doses up to four critical organs are summed and printed by sector and downwind distance. Population doses (person-rem) are

also calculated. Ground deposition, cloud depletion, and first daughter product ingrowth are considered in the calculations. In-plant holdup time and in-plant radionuclide decontamination factors may be provided as input data if desired. Radionuclide dose contributions are calculated for up to four critical organs. The code is dose model independent.

Two general classes of dose calculations are treated explicitly. These are: doses that are directly proportional to the ground level air concentration of radionuclides, and whole body doses due to gamma rays emitted by nuclides in the overhead cloud (cloud gamma doses).

Doses from inhalation, external beta, and transpiration dose modes are directly proportional to ground level radionuclide concentrations. For these dose modes "dose conversion factors" (DCF's) are used to relate dose data to concentrations. DCF's are derived from appropriate model(5).

Cloud gamma doses are calculated using dose tables obtained from a model that considers the finite extent of the cloud in the vertical direction.

For the calculation of whole body doses due to gamma rays emanating from radionuclides in the overhead airborne cloud (cloud gamma doses), we utilized dose integrals obtained from a model that considers the finite extent of the cloud.

Gamma doses are calculated using a sector-average diffusion model based on a crosswind integrated gaussian plume constrained between the ground and an inversion lid. A slightly modified and corrected version of Cooper's EGAD code (6) was used to produce a table of dose integrals appropriate to the effective stack height and lid height ( $H_{lid}$ ) for the facility. The table of dose integrals is interpolated for specific gamma energies and vertical dispersion coefficients.

Metrological data were analysed by Hsia's method (7). Environmental radiation doses around the TRR are measured by thermoluminescent dosimeter and environmental monitoring system.

### 3. RESULTS AND DISCUSSION

The calculated and measured environmental radiation doses for each season



were in fairly good agreement within 27%, provided 1) the reactor locates at open area, 2) there must be detailed reactor operation record and 3) hourly meteorological data. The annual environmental radiation doses around the TRR are shown in Figure 1.

#### REFERENCES

- (1) Tsai, C.M., editor, Institute of Nuclear Energy Research Rep. INER-TO 483 (1975) PP. 160-164 (in Chinese)
- (2) Soman, S.D., Abraham, P., "Health Physics", 11 (1964) 497
- (3) Liu, K.Y., Hsia D.Y., Chen T.K., "Nuclear Science Journal", 12,4(1975) PP. 171-182 (in Chinese)
- (4) Jr. Martin, J.A., Nelson, C.B., Cuny,P.A., "A Computer Code for Calculation Doses, Population Doses, and Ground Depositions due to Atmospheric Emissions of Radionuclides", U.S. Environmental Protection Agency Rep. EPA-520/1-74-004 (1974)
- (5) Turner, Wm.D., Kaye, S.V., Rohwer, P.S., "EXREM and INREM Computer Codes for Estimating Radiation Doses to Populations from Construction of a Sea-Level Canal with Nuclear Explosives", Oak Ridge National Laboratory Rep. K-1752 (1968)
- (6) COOPER, R.E., "EGAD-A Computer program to compute dose integrals from external gamma emitters, DP-1304 (TID-4500, UC-32). E.I.Dupont de Nemours & Company, Savannah River Laboratory, Aiken (1972)
- (7) Hsia, D.Y., "Health Physics", to be published.

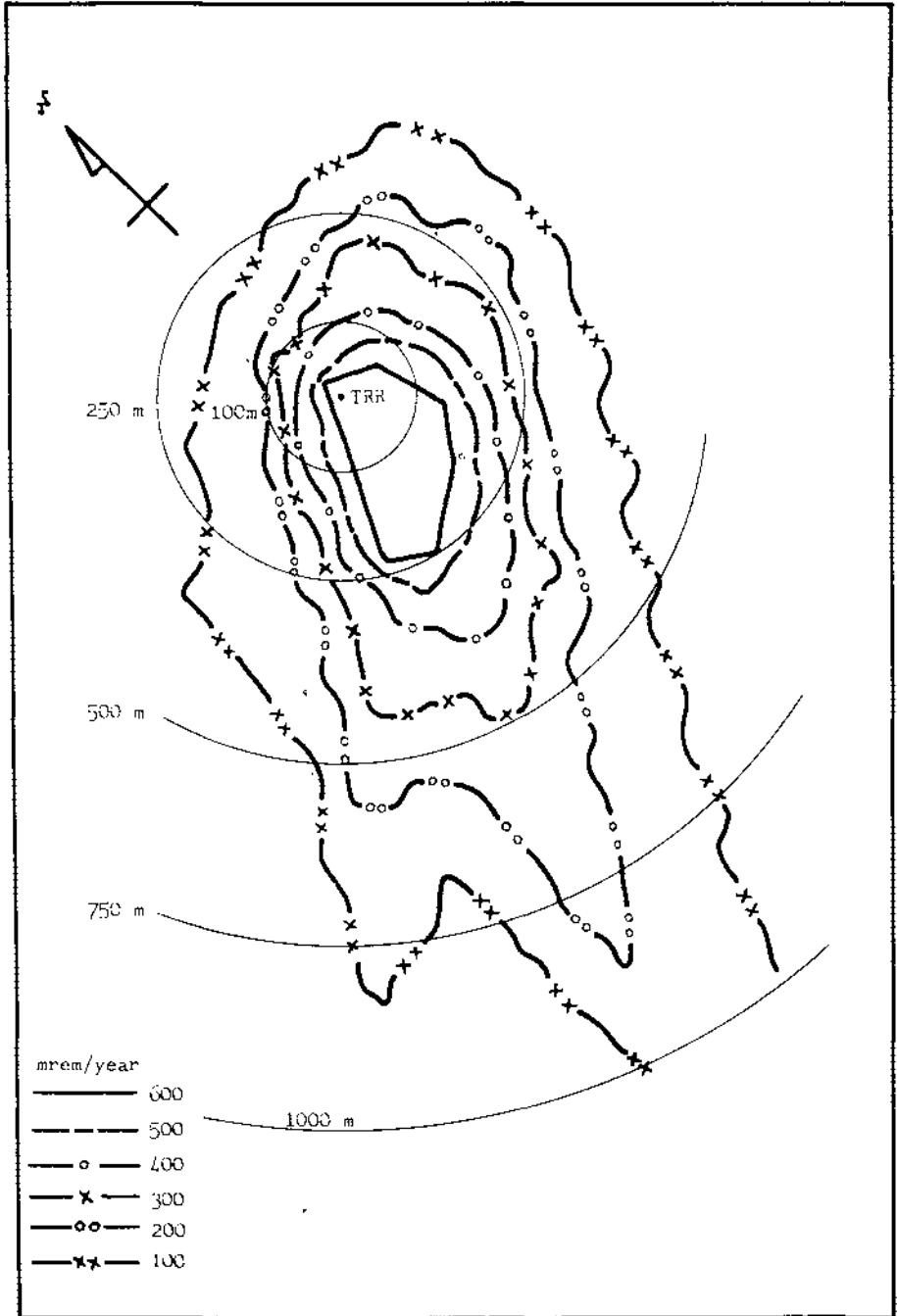

Figure 1. Annual environmental radiation doses around the TRR from May 1975 to Apr. 1976

A COMPUTER CODE FOR CALCULATING THE ATMOSPHERIC TRANSPORT OF  
 RADIOACTIVE POLLUTANTS UNDER INHOMOGENEOUS AND INSTATIONARY  
 CONDITIONS

Wüneke, C.-D., H. Schultz, E. Veelz  
 Arbeitsgruppe für Technischen Strahlenschutz  
 der Technischen Universität Hannover  
 Callinstrasse 15, 3 Hannover, F.R. of Germany

### 1. INTRODUCTION

For calculations of atmospheric dispersion of radioactive emissions from the nuclear industry under instationary and inhomogeneous conditions, numerical computer codes using the particle-in-cell method are developed by several groups for example by LLL (1) and 3S (2), and our group (3). This method simulates the pollutant dispersion in the atmosphere by the transport of Lagrangian particles in an Eulerian grid mesh and in a given wind field.

These programs can be successfully applied even when the turbulent and advection wind fields are varying so strong in time and space during the dispersion of the radioactive pollutant cloud, that calculations with the Gaussian plume model will fail. These particle diffusion programs have the advantage to eliminate the fictitious diffusion inherent in conventional finite-difference techniques in the case of inhomogeneous wind fields. Individual and multiple, instantaneous and continuous sources can be applied. Besides these codes can handle rainout and washout, wet and dry deposition and surface roughness variable in space. Introducing a particle weight the codes are capable of considering the radioactive decay and potential chemical effects of the pollutant.

### 2. PARTICLE-IN-CELL METHOD

In these programs the Lagrangian particles are moved in the Eulerian grid according to a given time step and to a velocity linearly interpolated from the velocities at the eight cell corners to the position of the particle. The velocities at the cell corners are composed of the advection velocities  $\vec{u}$  given from the wind field and by a net-diffusion velocity  $\vec{w}$  calculated by a difference-scheme of the pollutant concentration  $c$ .

In a turbulent field a concentration gradient  $\text{grad } c$  causes a net-current density  $\vec{j}$  in the opposite direction:

$$\vec{j} = -K \text{ grad } c = -K \cdot \nabla c$$

with the diffusion coefficient  $K$ .

Then a net-diffusion velocity can be defined:

$$\vec{w} = \frac{\vec{j}}{c} = -K \frac{1}{c} \text{ grad } c = -\frac{K}{c} \nabla c$$

So this model solves the nonlinear transport diffusion equation

$$\frac{\partial c}{\partial t} + \vec{u} \cdot \nabla c = \nabla \cdot (K \cdot \nabla c)$$

Under the assumption of incompressibility of the mass-consistent advection wind field the term  $\vec{u} \cdot \nabla c$  can be replaced by  $\nabla(c \cdot \vec{u})$  and with a so-called pseudoveLOCITY  $\vec{v} = \vec{u} + \vec{w}$  we can rewrite the equation:

$$\frac{\partial c}{\partial t} + \nabla c(\vec{u} - \frac{K}{c} c) = \frac{\partial c}{\partial t} + \nabla(c \cdot \vec{v}) = 0$$

That corresponds to a compressible pollutant gas, which can be simulated by an adequate distribution of pollutant particles.

### 3. PROGRAM XPIC

Based on the mentioned mathematical scheme we have developed the program XPIC, the flow-chart of which is shown in fig. 1. For practical use the code has been developed in two versions: one for handling single clouds over wide ranges with an expanding Eulerian grid, and the other for multiple sources in a limited area with a very large number of fixed cells.

#### Version A:

In the code version A the grid system follows the cloud path with cells stepwise expanding. Whenever the cloud border would begin to leave the grid system, the cell dimensions are enlarged in correspondence with changed time steps as mentioned later. Because of the limited memory capacity of our computer (CDC CYBER 73/76), at the moment the version A can handle about 26 000 particles in a grid system up to 10 000 cells. Fig. 2 shows the vertical concentration profile at distance 3 km from the source in the free atmosphere or with earth surface. In each case the dispersion is calculated by the Gaussian plume model or by XPIC. The difference of the concentration values in the lowest cell is probably caused by the different reflection mechanism of XPIC and the Gaussian model.

#### Version B:

For some problems as above-mentioned, the grid system of version A is too small. Because of the restricted memory capacity of our computer, we performed the calculations by tracking the particles group-wise and by handling the grid system in sections. Until now total grid systems of up to 100 000 cells can be handled by this way in version B, but the number of cells can be increased greatly by a not too difficult programming. In each version any desired number of particles can be transported, if the necessary computer time is available.

If there is no initial concentration distribution given by measurement or calculation, in both versions (single or multiple source) a cloud of Gaussian distributed particles may be injected at the beginning of each time step. The initial growth of the clouds is calculated by the common Gaussian plume model, until the curvature of the cloud can be reproduced by the PIC-method according to the desired accuracy.

To warrant a faultless dispersion of a pollutant cloud across the border of the grid system in the version B, special boundary conditions have to be observed, e.g. by linear extrapolating the diffusion velocities at the free-air boundaries of the grid system.

For evaluating the correct concentration on the earth surface, we had to introduce a special handling of the particles in the lowest layer of cells. Two different techniques, for assigning diffusion velocity to the particles in this layer seemed to be applicable:

- a) linear interpolation according to the vertical position of the particle between the diffusion velocity value zero at the surface and the value on the upper border of the lowest cell layer calculated by the normal difference scheme,
- b) statistically sampling between both values and assigning the diffusion velocity to the particle positions.

The case a) seems to agree with linear decrease of eddies whereas case b) seems to simulate a constant eddy spectrum in this layer. An option is installed for total reflection or a certain surface adsorption rate, e.g. by a Russian Roulette for killing the particles. Concerning the calculation of the diffusion coefficients used in this code, it is referred to Voelz et al., paper 161.

The concentration time integral at a reference point is got by adding all concentration values weighted by the time step during the time of interest. Assuming that a single cloud is unchanged during the passage along the reference point, it is possible in the code version A to calculate the concentration time integral by adding up all concentrations along the trajectory across this point.

#### 4. ACCURACY

To avoid inaccuracies by using a difference scheme certain rules must be observed for proportioning the cell dimensions of the Eulerian grid system and the time intervall at the Lagrange step.

First the cell dimensions must be adjusted appropriately to the curvature of the Gaussian distribution at the beginning of the calculation. Therefore the diffusion velocities which are calculated by the difference scheme are compared with those of the differential solution by the Gaussian plume model. The relative deviation  $\beta$  is given by

$$\beta = 1 - \frac{1}{c} \frac{\Delta c}{\Delta x_1} \bigg/ \frac{1}{c} \frac{dc}{dx_1}$$

Under the assumption, that the mean concentration values in the cells are given by

$$c = c_0 \cdot \exp(-x_1^2 / 2\sigma_1^2)$$

follows  $\alpha = \frac{1}{1-\beta}$  then with  $\alpha = x_1 \Delta x_1 / 2\sigma_1^2$

Besides, normally the timestep has to be adjusted to the cell dimensions and must satisfy the following inequation:

$$\Delta t \leq f \cdot \Delta x_1 / (v_i)_{\max}$$

where  $f$  is a constant in the range between 0 and 1 and  $(v_i)_{\max}$  is the  $i$ -component of the maximum pseudo-velocity. Without advection velocity, the pseudo-velocity is equal to the

diffusion velocity  $w$ , with  $(w_i)_{\max} = 2 X_i/\Delta x_i$  in XPIC. Without advection in XPIC therefore follows:  $\Delta t \leq \varepsilon \cdot \Delta x_i^2 / 2K_i$ .

### 5. CONCLUSION

In the meantime the code was also used for investigations concerning different vertical distributions of the diffusion coefficient and the wind speed as prepared by Voelz et al. paper 161. Further problems have to be solved concerning the evaluation of the wind field from meteorological data, the effect of surface structure, the optimization of the calculation process and the improvement of handling very large grid systems. These investigations are sponsored by the Ministry of the Interior of the F.R. of Germany.

### REFERENCES

- (1) LANGE, R., ADPIC - A Three-Dimensional Computer Code for the Study of Pollutant Dispersal and Deposition under Complex Conditions, Lawrence Livermore Laboratory, UCRL-51462(1973)
- (2) SKLAREW, R.C., FABRICK, A.J., PRAGER, J.E., A Particle-in-Cell Method for Numerical Solution of the Atmospheric Diffusion Equation, and Applications to Air pollution Problems 3 SR-844 (1971), Systems, Science and Software, La Jolla, California
- (3) SCHULTZ, H., VOELZ, E., WÜNEKE, C.-D., 2. Halbjahresbericht 1975 zum Thema 4312-TUS KFK 2262, Erstellung und Erprobung eines neuen Rechenprogramms für die Berechnung der Ausbreitung von Schadstoffen in der Atmosphäre unter instationären Bedingungen in ausgedehnten bebauten Regionen.

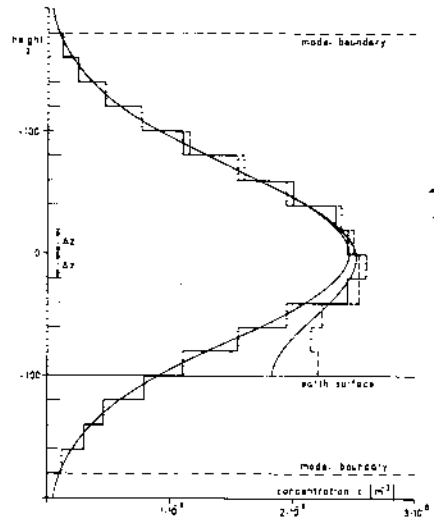
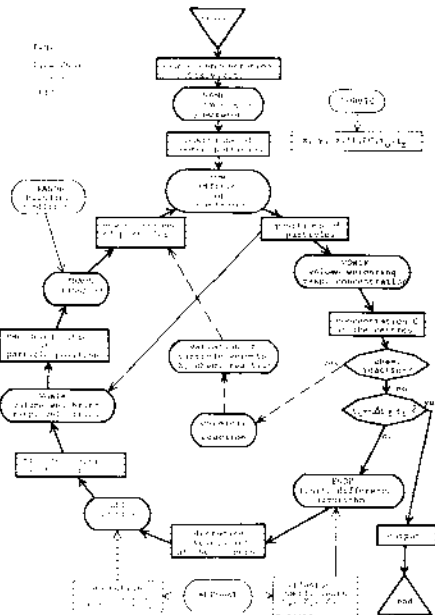

Fig. 1. Vertical concentration profiles calculated by ADPIC. The concentration profiles are shown at the maximum height of the plume, 5 km downwind from the source. The concentration profiles are shown at the maximum height of the plume, 5 km downwind from the source.

METEOROLOGICAL DIFFUSION MODELS FOR A COMPUTER PROGRAM FOR INSTATIONARY AND INHOMOGENECUS DISPERSION OF RADICACTIVE POLLUTANTS.

E. Voelz, H. Schultz, C.-D. Wüneke  
Arbeitsgruppe für Technischen Strahlenschutz  
der Technischen Universität Hannover  
Callinstrasse 15, 3 Hannover, F.R. of Germany

### 1. INTRODUCTION

At present the dispersion of a plume in the atmosphere is almost only described by the Gaussian plume diffusion model. For this purpose over the cloud width averaged values are used for the determining parameters; that are the wind direction, the wind speed and the standard deviations  $\sigma_i$  of the plume model respectively the constants  $K_i$  of the turbulent diffusion. But it is well-known that the wind speed increases with height and that the constants  $K_i$  somehow change with height, too. This height-dependence is not explicitly taken into account in the Gaussian plume model. Instead of this the diffusion calculations are performed with standard deviations, which are fitted to the spreading cloud by measurements of the ground level concentrations. In this way only one mean value is specific for the whole cloud at a fixed distance of the source. But, if there is a substantial change of the determining parameters within the cloud, this model does not reflect the spreading exactly.

If instationary or inhomogeneous effects are to be considered, as for example, the influence of the height-dependent determining parameters or their variations with time, a numerical solution has to be used, as is done here in the so-called "particle-in-cell method". Therein the space is divided into single cells, to which the determining parameters can be locally fitted. Between these cells the diffusion is evaluated by numerical difference schemes. In contrast to the Gaussian model the particle-in-cell method uses only averaged or interpolated values for the concentration and for the determining parameters within each cell. This method is described in report No. 160 by C.-D. Wüneke et al.

### 2. STATISTICAL THEORY

By means of the statistical theory, a turbulent diffusion coefficient  $K_i$  averaged over the total range of the cloud can be calculated for each direction  $i$  with the standard deviations  $\sigma_i$ , e.g. from the system of Pasquill (1962)

$$(1) \quad K_i = 0.5 \cdot \bar{u} \cdot d\sigma_i^2/dt$$

Calculations using adequately interpolated  $K_i$  in the particle-in-cell method give nearly the same results as the Gaussian model with the  $\sigma_i$ , see paper No. 160. The concentrations and their time integrals at ground level that are proportional to the external cloud-Beta-dose, are a little bit greater due to a different simulation of the reflection at the surface.

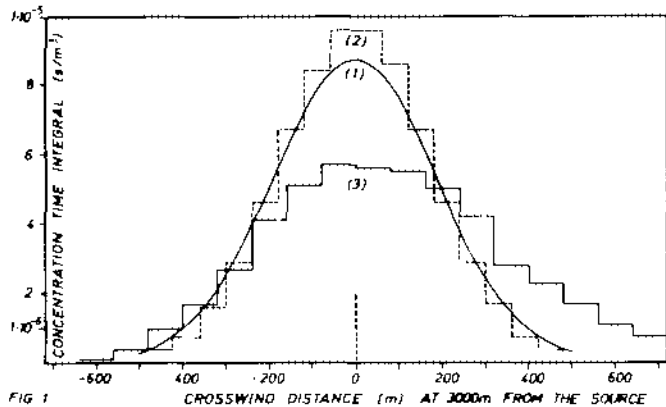

FIG. 1

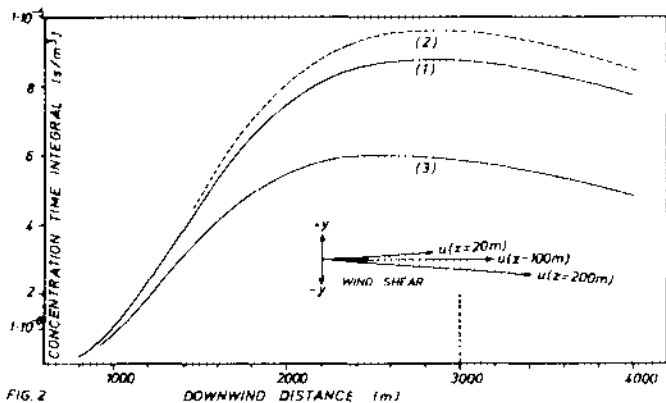

FIG. 2

Normalized concentration time integrals of a 100 m high point source emission under neutral conditions for the Gaussian plume model (1) and for the particle-in-cell method with a wind profile (2) and with an additional wind direction shear (3)

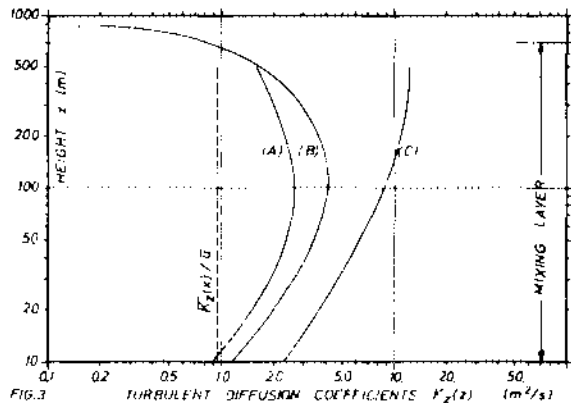

FIG. 3

Turbulent diffusion coefficients  $K_z(z)$  under neutral conditions from Suckale (A), from Appertman (B) and from the simplified solution (C) in comparison with the normal value (stat. value  $K_z(z) = 0.25 \times z^2$  m<sup>2</sup>/s) of the statistical theory.

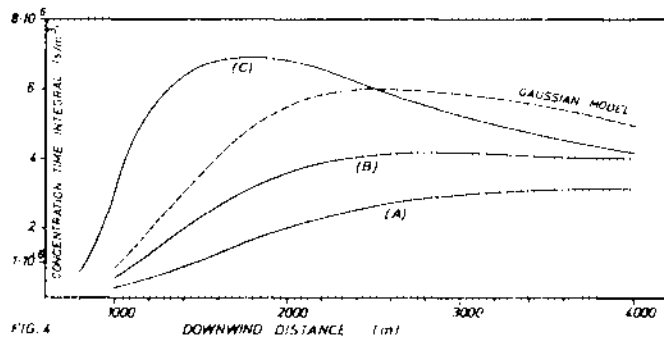

FIG. 4

Normalized concentration time integrals of a 100 m high point source emission under neutral conditions, calculated with the  $K_z$  values from Suckale (A), from Appertman (B) and from the simplified solution (C) in comparison with the Gaussian model.



If a height-dependent wind speed in the power-law form is introduced in the particle-in-cell method, the calculations yield in lower concentrations in the cloud center. On the other hand, this leads to a spread over a longer distance, so that the concentration time integrals at the surface stay nearly unchanged and give the same values, as are computed with a constant wind speed in the Gaussian model. This is to be expected, because the applied standard deviations are derived, in such a way that they include the effects of the vertical wind profile.

This calculation, repeated with an additional height-dependent wind direction shear, yields in a lower concentration time integral, which is due to an additional cloud extension in the crosswind direction. The wind shear causes the concentration time integral to decrease in the direction of the cloud center line and to increase in the twisted direction of the surface wind. In fig. 1 and 2 the concentration time integrals downwind under the cloud center line and crosswind at a source distance of 3000 m are shown for a 100 m high point source emission with both a height-dependent wind speed and an additional wind direction shear.

### 3. HEIGHT-DEPENDENT DIFFUSION COEFFICIENTS

Also the height-dependence of the vertical turbulent diffusion coefficients  $K_z = K_z(z)$  can be simulated in the particle-in-cell method. It can be derived theoretically from various physical theories, for example:

- A. By means of the mixing length hypothesis, Blackadar(1962) deduces a relationship between the height-dependent turbulent diffusion coefficients  $K_z(z)$ , the mixing length  $l(z)$  and the profile of the wind speed  $u(z)$ . For this case,  $u(z)$  must be measured and  $l(z)$  must be detected by supplementary parameters. Primarily the method is derived for neutral diffusion conditions, but it can be formally transmitted to other cases by varying  $l(z)$  according to the atmospheric stability, as has been done by Wippermann (1973).

$$(2) \quad K_z(z) = l^2(z) \cdot |du/dz|$$

Wind speed	$u(z) = u(z_0) \cdot (z/z_0)^{0.28}$
Mixing length	$l(z) = \kappa \cdot z / (1.0 + \kappa \cdot z/l_\infty)$
Blackadar (1962)	$l_\infty = 0,00027 \cdot u_g/f$
Wippermann (1973)	$l_\infty \approx l(\mu)$

with  $l_\infty$  the mixing length in the free atmosphere;  $u_g$  geostrophic wind speed;  $f$  the Coriolis parameter;  $\kappa$  the von Karman constant; and  $\mu$  a special stability parameter presented by Wippermann (1973).

- B. Wippermann (1973) calculates local  $K_z(z)$ -values by solving numerically the Navier-Stokes equations.

$$f(u_y - u_{yg}) + \frac{d}{dz}[K_z \cdot \frac{d}{dz}(u_x - u_{xg})] = 0$$

$$-f(u_x - u_{xg}) + \frac{d}{dz}[K_z \cdot \frac{d}{dz}(u_y - u_{yg})] = 0.$$

These equations are solved with a complete set of the meteorological and determining parameters. The resulting  $K_z(z)$ -values are shown in diagrams. The calculations are first published only for neutral diffusion. A transmission to other diffusion types seems to be possible.

C. For a simplification, we have solved the Navier-Stokes equations with simplified assumptions on the wind speed and the wind shear.

$$\begin{aligned} \text{Wind speed} & \quad v^2(z) = u^2(z) [\cos^2 \alpha(z) + \sin^2 \alpha(z)] \\ \text{Angle of the wind shear} & \quad \alpha(z) = \alpha_g + z/D \end{aligned}$$

$\alpha_g$  is the wind shear at height  $D$  of the mixing layer.

But no horizontal  $K_x$ - or  $K_y$ -values can be taken from all these models. For a first investigation,  $K_x$  and  $K_y$  are assumed to be decoupled of  $K_z$ , and therefore the corresponding diffusion coefficients  $K_x(x)$  and  $K_y(y)$  for the statistical theory are used. The resulting coefficients  $K_z(z)$  are shown in fig. 3. The corresponding concentration time integrals are calculated with the particle-in-cell method and are shown in fig. 4. The turbulent diffusion coefficients presented by Blackadar (1962) and by Wippermann (1973) lead to concentration time integrals lower than those calculated in the Gaussian model under corresponding conditions. These are caused by the lower  $K_z(z)$ -values, compared to the normalized values given by the statistical theory, as can be seen in fig. 3. This is in contrast to measurements made in Jülich und Karlsruhe. On the other hand, the approach with the simplified assumptions for the Navier-Stokes equations leads to higher maxima of the concentration time integral being closer to the source. This is in accordance with the comparably higher  $K_z(z)$ -values.

#### 4. CONCLUSION

For the future further investigations from the computational and meteorological point of view are intended, especially with respect to the nonneutral diffusion conditions. If these problems are solved and if the necessary input data are available, the particle-in-cell method seems to be of advantage.

These investigations are sponsored by the Ministry of the Interior of the F.R. of Germany.

#### REFERENCES

- (1) BLACKADAR, A.K., The Vertical Distribution of Wind and Turbulent Exchange in a Neutral Atmosphere, J. Geophys. Research, Vol. 67, No. 3 July (1962)
- (2) PASQUILL, F., Atmospheric Diffusion, van Nostrand (1962)
- (3) WIPPERMANN, F., The Planetary Boundary Layer of the Atmosphere, Annalen der Meteorologie, Deutscher Wetterdienst, p. 314-321, Offenbach (1973)

A COMPOSITE DOSE CALCULATION MODEL  
FOR LOCAL, REGIONAL AND GLOBAL ATMOSPHERIC DISPERSION

Christina Cyllander, Anders Sandström<sup>x)</sup>, Ole Karlberg, Ronny Bergman, Ulf Widemo, A9 Atomenergi, Studsvik, S-611 01 Nyköping, Sweden.

The investigations were commissioned by Swedish authorities, and the aim of the project has been to establish relationships between release rate and resulting dose, both as regards individuals and populations. To meet this demand further development has been requested to devise models for the computation of regional and global doses.

In this paper a composite model including local, regional and global scale dispersions is presented. This model permits the calculation of individual and collective dose.

The generalized Gaussian plume formula has been used to study a local zone 0-50 km from the release point. (1) (2).

The regional model which is applied to distances from 50 km out to 2000 km is based on a statistical approach that uses geostrophic trajectories in two levels to determine the horizontal dispersion (3). A special program has been written to evaluate the vertical dispersion, consideration being given to the dispersion and deposition of daughter products.

A compartment model is introduced to determine on a global basis the collective dose commitment from long-lived nuclides. (4) (5).

This composite model is capable of computing the external and internal doses delivered by clouds as well as the radiation contribution from the ground. The dose program can be linked to a data file which describes the population distribution in a net of spherical triangles of different orders. (6). This yields the collective dose to selected populations.

The accuracy of these models has been checked by comparing the results obtained using two models within boundary areas. These comparisons are of the local model as opposed to the regional model in the interval 20-50 km and the regional model as opposed to the global model in a zone 30-60°N. These tests showed that there is good agreement between results obtained with different models in the boundary areas. Furthermore, the global model has been checked against observed global values of C14, the natural production of which has been fairly well determined.

---

x) Present address: Statskontoret, Fack, S-100 26, Stockholm, Sweden

Basically, the analysis is performed for a unit release of 1 Ci per year of each of 26 nuclides of particular interest to the normal operation of a nuclear power plant. The distribution of the collective dose at local, regional and global levels is presented for different nuclides. The individual dose at 1 km as well as the total collective dose commitment has furthermore been computed for a BWR system with three alternative off-gas systems and for a PWR system.

The model has been adapted to compute the dose impact on the population from a large number of nuclear power plants. It is accordingly possible to determine the contribution made by a particular nuclear power program to the total population dose.

In order to illustrate the procedure the following examples are presented:

Diagram 1: Individual dose (Rem/yr) caused by the release of 1 Ci of Xe135 per year from each of the Forsmark and Barsebäck sites, located in the middle and the south of Sweden respectively.

Table 1: Collective dose commitment (Manrem/MW<sub>yr</sub>) for a BWR reactor at Barsebäck with recombiner, iodine and aerosol filters.

#### References

- 1 HÖGSTRÖM U  
An experimental study on atmospheric diffusion  
Tellus 16 (1964) p. 205.
- 2 KARLBERG O, SCHWARTZ H, FORSSEN B-H, MARKLUND J-E  
A universal program for calculation of individual and population doses (To be published)
- 3 BOLIN B and PERSSON C  
Regional dispersion and deposition of atmospheric pollutants with particular application to sulfur pollution over Western Europe  
Tellus 27 (1975) p. 281.
- 4 BERGMAN R and McEWAN C  
Exposure and dose commitment due to global carbon-14 from the nuclear industry  
AB Atomenergi, Sweden, 1977 (Report to be published)
- 5 BERGMAN R and McEWAN C  
AB Atomenergi, Sweden, 1977  
(Internal report to be published)
- 6 WICKMAN E, ELVERS E and EDVARSON K  
A system of domains for global sampling problems  
FOA 4 report D 4263-AR81 (Sept. 1973)

Table 1. COLLECTIVE DOSE COMMITMENT (Man rem/MW<sub>e</sub>yr)

BWR with recombinator, iodine and particle filters

I Release values computed, core failure 0.1 Z

II Release values observed, core failure unknown

Nuclide	Release rate Ci/MW <sub>e</sub> yr	Collective dose commitment			
		Local 0-50 km	Regional 50-2000 km	Global > 2000 km	Total
I					
Kr 83m	7.9E-02	1.8E-08	1.4E-09	-	2.0E-08
85m	2.9E-00	1.2E-04	1.1E-05	-	1.3E-04
87	3.3E-01	5.3E-05	1.7E-06	-	5.5E-05
88	2.0E+00	1.4E-03	1.2E-04	-	1.6E-03
89	2.9E+00	4.8E-05	1.1E-06	-	4.9E-05
Xe 131m	1.3E-01	2.8E-07	3.4E-07	-	6.2E-07
133m	2.6E+00	5.0E-05	1.2E-04	-	1.7E-04
133	6.6E+01	1.5E-03	4.0E-04	6.0E-04	2.5E-03
135m	6.6E-01	1.1E-05	4.8E-07	-	1.2E-05
135	1.3E+01	1.6E-03	2.9E-04	-	1.9E-03
137	3.3E+00	1.2E-06	-	-	1.2E-06
138	1.3E+00	2.8E-04	-	-	2.8E-04
139	1.3E+00	4.0E-08	-	-	4.0E-08
I					
131	2.4E-03	4.0E-04	2.6E-04	1.2E-03	1.9E-03
132	5.2E-03	1.1E-05	7.2E-07	-	1.2E-05
133	9.3E-03	3.4E-04	4.4E-05	-	3.9E-04
134	7.3E-03	4.1E-05	1.0E-07	-	4.1E-05
135	6.6E-03	5.3E-05	7.9E-06	-	6.1E-05
II					
H3	1.0E-01	3.1E-05	1.2E-05	4.0E-04	4.4E-04
Cl4	6.0E-03	7.2E-05	7.8E-05	1.6E+00	1.6E+00
Kr85	1.7E-02	2.6E-08	1.9E-08	8.5E-06	8.5E-06
Sr89	1.6E-05	3.7E-07	1.8E-07	1.7E-05	1.2E-05
Sr90	3.9E-06	1.7E-06	8.4E-07	1.2E-03	1.2E-03
Cs134	5.2E-06	4.0E-07	1.1E-07	1.3E-04	1.0E-04
Cs137	4.7E-06	1.7E-07	1.1E-04	7.0E-04	8.1E-04
Ba140	3.0E-04	2.3E-06	1.3E-06	2.1E-05	2.5E-05
Z		6.0E-03	1.4E-03	1.6E+00	1.6E+00

NO	DOSE
1	0.146E-10
2	0.128E-11
3	0.384E-11
4	0.182E-11
5	0.910E-12
6	0.455E-12
7	0.237E-12
8	0.114E-12
9	0.588E-13
10	0.284E-13
11	0.142E-13
12	0.711E-14
13	0.355E-14
14	0.178E-14
15	0.889E-15
16	0.444E-15
17	0.222E-15
18	0.111E-15

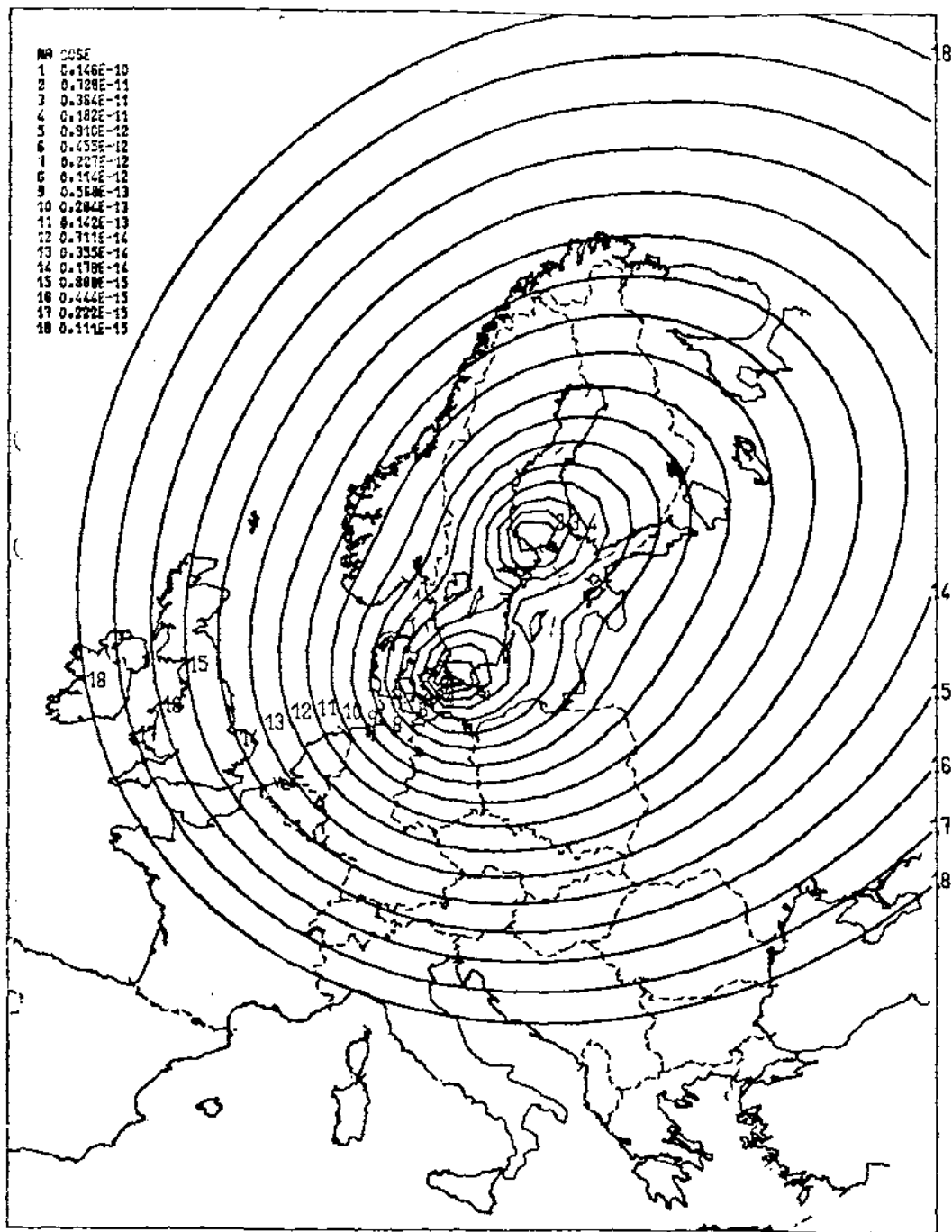

76524-3, IE 135, 1 CI/YEAR FROM BOTH BARSEBAECK AND FORSMARK. SHIELDING  
 FACTOR = 0.35. DOSE RATE IN REM/YEAR. TRAJECTORIES FROM JOENKÖPING,  
 EXT. WHOLE BODY DOSE

$3.5 \cdot 10^{-5}$  manrem/Ci

PARAMETRIC STUDY OF THE INFLUENCE OF THE ATMOSPHERIC DIFFUSION PARAMETERS  
ON THE SHORT AND LONG TERM EXPOSURE ESTIMATES

S. Chakraborty  
Nuclear Safety Division  
EP-5393 Würenlingen / Switzerland

## 1. INTRODUCTION

In the atmospheric diffusion calculations the diffusion parameters play an important role which has been stressed by different authors. Thus the Pasquill's values for the diffusion parameters are not universal and have been compared (1, 2) with values obtained from the tracer experiments carried out in Illich, West Germany.

It was found that due to the surface roughness, there is a shift of the maxima of diffusion factors towards the source and their values are usually higher than the Pasquill's values. However, in the practical field of interest, e.g. the emission of radioactive noble gases from routine operation of nuclear power plant or from an accidental release, it is the calculation of cloud gamma doses which is of ultimate interest.

In this report the calculation of cloud gamma doses is carried out with different diffusion parameters in order to study their sensitivity.

The computer code ATRIM (3) is applied separately for annual and accidental dose calculations which involve respectively longterm and shortterm dispersion.

## 2. CALCULATION OF CLOUD GAMMA DOSES

The ATRIM code used for the calculation of cloud gamma doses is based on sector averaged Gaussian diffusion equation compatible with wind rose data. This code is primarily written for average annual dose calculations. The code can, however, also be used for calculation of doses from the release of radioactive materials over a shorttime duration. This is verified through the comparison of measured and calculated values which is also reported in another paper to this conference (4).

A release of 100 Ci of Argon-41 at a height of 100 m is here assumed. A finite extent of the cloud is considered because of large gamma energies of Argon 41. This finite cloud model is provided by the computer code ECAD (3). The different vertical diffusion parameters are the experimental values of Pasquill, Brookhaven laboratory and Illich (at 50 m and 100 m height).

The annual average dose calculation is on the basis of the Würenlingen meteorological statistics. The annual doses from one major wind sector (SSW) are plotted in Fig. 2. As may be seen, the differences on the doses occur only at larger distances for different diffusion parameters and are insignificant for the purpose of this estimation.

For the short-time (1 h) release the wind velocity of 2 m/s is considered. The results of the calculations using different diffusion parameters for two different diffusion categories are displayed in Fig. 1.

In case of the diffusion category B there is almost no difference in doses for the dilution (50 m and 100 m) and backscattered beta of parameters.

Pronounced differences are seen for the category C. This is understood from the scattered diffusion factors for this category, shown in Fig. 8. The curve from the dilution (50 m) parameters is quite different from those with others for the category C.

The diffusion parameters have a little influence on the dose for the category A. For the category B the curves for the Pasquill and Brankovskij parameters are overlapping and show only a little difference with other parameters.

Up to a distance of 5 km the maximum dose difference when using two different diffusion parameters is found to be a factor of 3. However, this lies within the range of the uncertainty of the diffusion model (1) and consideration of different diffusion parameter sets is relatively unimportant to dose maximum dose calculations.

#### REFERENCES

- (1) Vogt, G.G., Solon, H. Report GM 133 St. (1974)
- (2) Vogt, G.G. "Empirical Investigation of the Diffusion of Water Air Plumes in the Atmosphere", Nuclear Technology (1977)
- (3) ATRM Program Manual, EPA 561/1-8-004 (1974)
- (4) Nagel, H., Tschakertsky, G. "Measurements of Gamma Doses and Derived Dispersion Factors in the Environment of a Nuclear Facility in a Typical Middle European Site", IAEA, IV Congress, Paris, 24-30 April (1977)
- (5) Martin, J.A., Jr., Solon, H.G. IAEA-64 121/32 from "Physical behavior of Radioactive Contaminants in the Atmosphere" (1974)



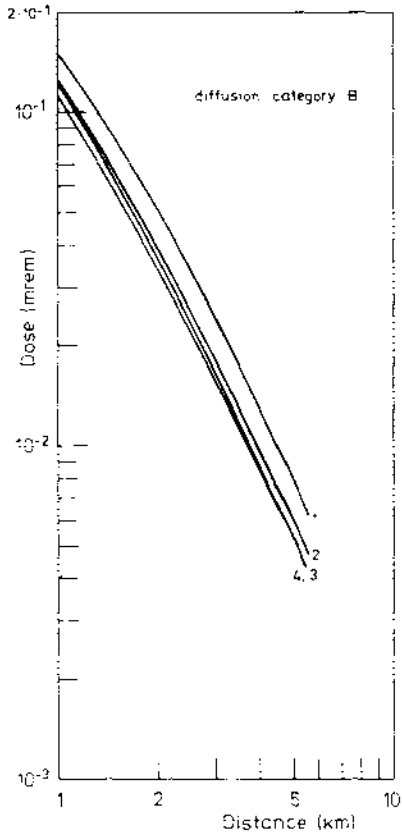

Fig 1

- Curve 1: Pasquill
- Curve 2: Gaussian (50 m)
- Curve 3: Gaussian (100 m)
- Curve 4: Brookhaven

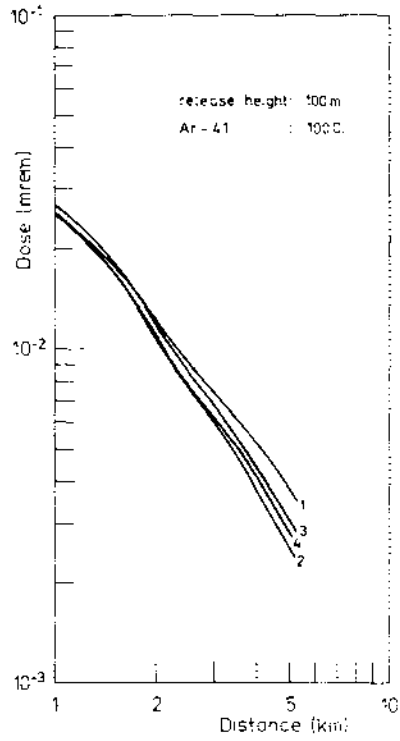

Fig 2

Average dose as a function of the source distance.

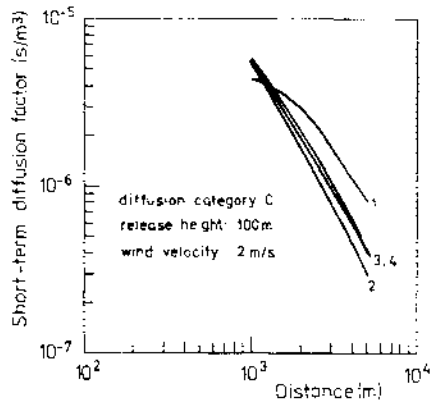
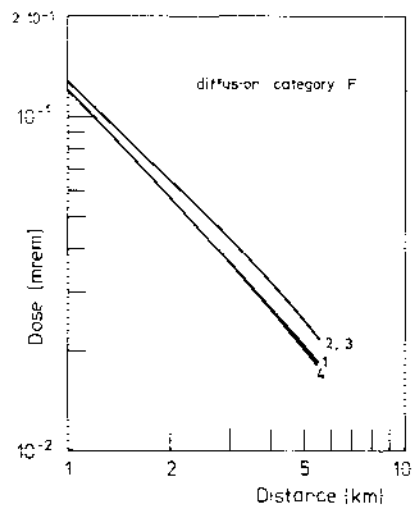
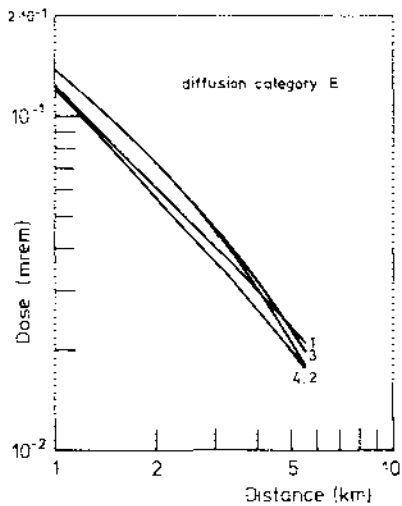
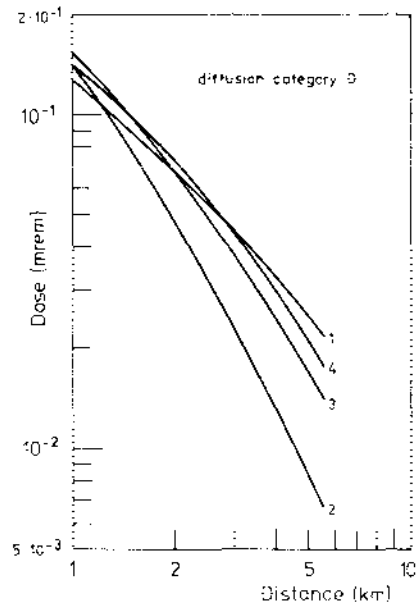
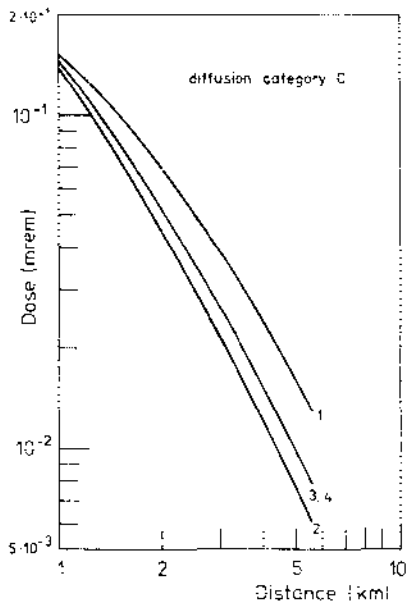

Fig 3

Short-term diffusion factor as a function of the source distance



Curve 1: Pasquill  
 Curve 2: Jilich (50 m)

Curve 3: Jilich (100 m)  
 Curve 4: Brookhaven

Fig. 1

Cloud gamma dose rate for a release height of 100 m and wind velocity of 2 m/s as a function of the source distance for the different diffusion systems calculated for the diffusion categories B-F.

ON THE USE OF TRAJECTORY MODELS FOR EVALUATION OF THE DISPERSION  
OF AIRBORNE RADIOACTIVITY IN NUCLEAR POWER PLANT ACCIDENT SITUATIONS

Göran G. Nordlund  
Finnish Meteorological Institute  
P.O. Box 503, Helsinki Finland

### 1. INTRODUCTION

Commonly, there are diagrams constructed in advance for calculating the dispersion of radioactive matter in an accident situation. Wind and stability values observed from some point (e.g. tower) near the plant, are used as meteorological input data. These values are then assumed to be valid for the dispersion up to several hundred kilometers from the plant. However, in most cases the orography and synoptic situation influence the dispersion so that this definitely cannot be described by data from a single observation point alone. The dispersion calculation should therefore be based on analysis of the wind and stability conditions over the whole dispersion area. To be of use in an accident situation, the method must be fast and simple to apply even on relatively small computers or calculators. The following describes the method developed at the Finnish Meteorological Institute for use as a complement to the diagram safety system.

### 2. CALCULATION OF THE DISPERSION TRAJECTORIES

Regular synoptic wind observations in the area surrounding the plant are used for calculating the dispersion trajectories. The wind analysis for each point required is performed by the relatively sophisticated "optimum interpolation" method introduced in meteorology by L.Gandix (1). The use of this method near the ground and in mesoscale has been discussed earlier (2).

### 3. ESTIMATION OF THE HORIZONTAL AND VERTICAL EXTENSION OF THE RADIOACTIVE CLOUD

For calculating the horizontal spread perpendicular to the trajectory,  $\sigma_y$ -values are used, as is usual in gaussian plume models. In order to get enough broad risk zones, the uncertainty of the trajectory computation should be added to the  $\sigma_y$ -estimate of the horizontal spread.

The vertical spread is simulated according to a K-theory approach:

$$\frac{\partial C}{\partial t} = \frac{\partial}{\partial z} \left( K_z \frac{\partial C}{\partial z} \right),$$

where  $C$  is concentration and  $K_z$  the vertical eddy diffusion coefficient. For the determination of the important  $K_z$ -values the planetary boundary layer (0-1000 m) is divided into three layers: a ground layer (0-1 m) in which the vertical spread only depends on the deposition velocity  $v_d$ , a surface layer (1-100 m) where  $K_z$  grows with increasing height according to

$$K_z = u_* z^2 f\left(\frac{z}{L}\right),$$

and a transition layer in which  $K_z$  is constant to the inversion. For the stability characteristics  $u_*$  and  $L$  (see e.g. (3)) values are given in advance for different synoptic situations.

#### 4. THE RELEASE INFORMATION AND THE OUTPUT

The above described dispersion calculation method does not include any procedures for estimating the amount and type of release. This information should be obtained in another way, as accurately as possible. The initial release height and the plume rise should also be estimated separately.

The trajectory is plotted on a map and for the distances  $z^n$  ( $n=1,2,\dots,8$ ) km values for the horizontal extension of the radioactive cloud and the ground level axial concentration  $C_0$  are tabulated. Further rough estimates of the corresponding time integrated  $\beta$  and  $\gamma$  submersion doses and the inhalation dose will be included in the output.

#### REFERENCES

- (1) Gandin, L.S. "Objective analysis of meteorological fields", Gidrometeorologicheskoe izdatel'stvo, Leningrad. Translated from Russian. Israel Program for Scientific Translations, Jerusalem, 242 pp. (1965).
- (2) Nordlund, G.G. "On the use of objective wind analysis for mesoscale dispersion calculations", Preprint volume of the Third Symposium on Atmospheric Turbulence, Diffusion and Air Quality, October 19-22, 1976 Raleigh, American Meteorological Society (1976).
- (3) Haugen D. (Ed.) "Workshop on Micrometeorology", Boston, American Meteorological Society, 392 pp. (1973).

ATMOSPHERIC DISPERSAL OF RADIOACTIVE POLLUTANTS OVER LONG DISTANCES  
AND THE CALCULATION OF COLLECTIVE DOSE

H.M. ApSimon and A.J.H. Goddard

Nuclear Power Section, Mechanical Engineering Department  
Imperial College of Science and Technology, London, S.W.7. 2BX

Factors affecting the convergence of collective dose with distance are important, as they will influence the range of the integration. For short-lived nuclides the region of convergence will be limited by decay, whereas for long-lived nuclides such as  $^{85}\text{Kr}$  global circulation over many years may have to be considered. For nuclides with half lives of a few hours to a few days, or for other nuclides which deposit or wash out, it may be necessary to model dilution to considerable distances.

### 1. ROLE OF VERTICAL DISPERSION IN CONVENTIONAL MODELLING

Traditional methods of estimating collective dose from a continuous atmospheric release involve Gaussian plume models. For a series of direction sectors the average atmospheric concentration is calculated as a function of distance by summing concentrations over weather categories such as the Pasquill A-F series according to their frequency. For each category the plume may be multiply-reflected between ground and an inversion at a typical height, and nuclide dependent depletion and decay may be allowed for. Assuming for simplicity an isotropic wind rose and a uniform population, collective dose is proportional to the integral over distance of

$$\phi(r) = 2\pi r \sum_i \chi_i(r) f_i$$

where  $f_i$  is the frequency of category  $i$  and  $\chi_i(r)$  the corresponding atmospheric concentration. Figure 1, for unit release rate, shows the dominance of stable conditions for a long-lived non-depositing nuclide. Frequencies  $f_i$  were taken from Bryant (1) and inversion heights are as in WASH-1400 (2) with a 37m release height.

### 2. VERTICAL DISPERSION IN THE MESOS MODEL

However it is not correct to assume that conditions at the source continue unchanged indefinitely, for due to diurnal changes in insolation, the dominance of stable conditions becomes increasingly implausible beyond approximately 20km. Weather conditions also vary with changes in wind strength and underlying terrain.

The computer program MESOS (3) treats releases of a few hours duration by following in detail the history of a series of discrete puffs of material and estimating their vertical dispersion in a more realistic way, taking into account temporal and spatial changes in the atmosphere and the underlying surface along the puff tracks. Each puff is represented by a vertical rectangular column moving with a mean wind estimated locally at the time of passage. The atmosphere is considered as a turbulent boundary layer of variable depth, well mixed by mechanical and convective processes, surmounted by stable layers (see Figure 2). Initially, material diffuses upwards from the bottom of a column at a rate depending on current local conditions until limited by mixing layer depth. Subsequent vertical mixing depends on changes in this depth; when it increases due, say, to insolation, material is diluted; if the mixing layer becomes shallower say, at night, some material is isolated in stable layers above and is not depleted

by dry deposition at the ground. Depletion by decay, deposition and washout are included in MESOS and the model of Carson (4) and Smith (5) is used to calculate mixing layer depths.

In Figures 3(a) and (b), vertical dispersion according to the Gaussian plume model and to the MESOS time dependent model are compared assuming that winds and underlying surface remain constant. Ci per metre thick layer within a puff, near the ground, are shown after various travel times and distances for a hypothetical 1 Ci release. In case (a) a long lived non-depositing nuclide (eg  $^{85}\text{Kr}$ ) is released in category F conditions, with an inversion at 100 metres, soon after dusk in midsummer. During the night the two models differ, but not significantly, due to the simplified initial treatment in the moving columnar puff model, (ignoring reflection terms). At dawn, insolation and convective mixing break up the stability of the atmosphere, dramatically depleting activity in the lowest layers.

In case (b), 1 Ci of  $^{131}\text{I}$  is released at midday in unstable category A conditions in Spring with an assumed deposition velocity of  $.003 \text{ m.s}^{-1}$ . Both models predict rapid vertical dispersion but in the time dependent MESOS model conditions become more stable towards dusk, giving less dispersion. During the night, activity in the upper layers is isolated from the lower layers which are depleted more rapidly by dry deposition. At dawn activity at low levels increases with fumigation. The evolutionary model thus leads to a fluctuating pattern of activity in the lowest few metres in these circumstances.

### 3. LATERAL DISPERSION IN MESOS

Lateral divergence between puff tracks due to divergence of winds on a synoptic scale gradually dominates lateral dispersion as travel times increase. In MESOS, while some lateral spreading of columnar puffs is included for small scale dispersive mixing, successive puffs are tracked with effective winds computed from geostrophic winds, using maps of surface pressures over the map area for successive 6 hour intervals. Figure 4 shows the tracks of 2 hypothetical puffs released 6 hours apart and tracked in this way, although in general MESOS tracks puffs released at hourly intervals through the release period. From time integrated atmospheric concentrations for overhead passage along the tracked puff paths and by interpolation, MESOS builds up, at a regular grid of points, integrated atmospheric concentrations corresponding to a release of a few hours duration. Figure 5 shows how integrated concentrations at grid points may be combined with population data and dose factors to yield a collective dose distribution; inhalation dose to the thyroid for a hypothetical 1 Ci release of  $^{131}\text{I}$  is shown.

These methods may be applied to releases of different nuclides under a wide range of weather conditions and at different times of day for specimen sites, to give a better understanding of the dispersion of material and convergence of population dose.

### REFERENCES

1. BRYANT, P.M., UKAEA Rep. AHSB (RP) R42 (1964).
2. "Reactor Safety Study", USAEC Rep. WASH-1400 (1974).
3. APSIMON, H.M. and GODDARD, A.J.H., "Modelling the atmospheric dispersal of radioactive pollutants beyond the first few hours of travel", 7th Int. Tech. Mtg. Air Pollution Modeling, Airlie, Virginia, (1976).
4. CARSON, D.J., Quart. J. R. Met. Soc., 99, 450-467 (1973).
5. SMITH, F.B., Met. Off. Boundary Layer Res. Branch Note TDN 63 (1975).

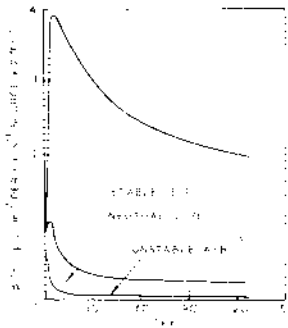

Figure 1. Distribution of collective dose for a continuous release of a long-lived, non depositing nuclide using "Gaussian" model

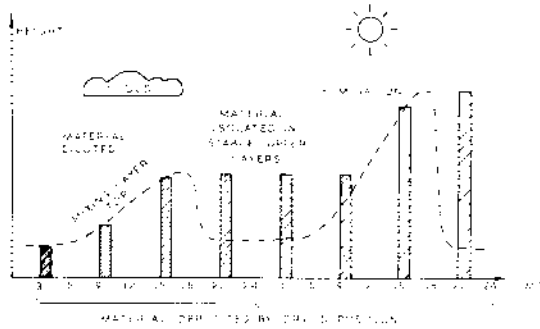
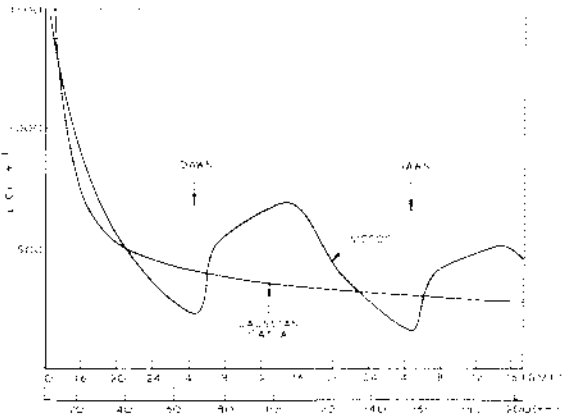
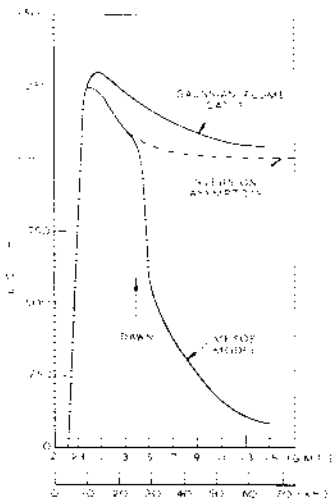

Figure 2. Typical diurnal behaviour of the mixing layer and the depletion of a strongly depositing nuclide.



(b) Hypothetical 1 Ci release of  $^{131}\text{I}$  at midday in category A conditions in Spring.

Figure 3. Comparison of activity per metre thick layer near ground, predicted by MESOS and by Gaussian model.

(a) Hypothetical 1 Ci release of long-lived non-depositing isotope, just after dusk in mid-summer

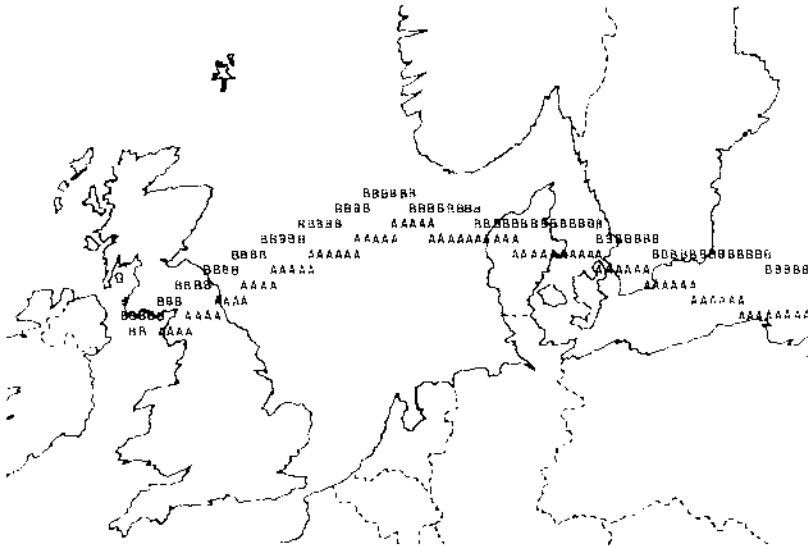

Figure 4. Tracking paths released 6 hours apart.

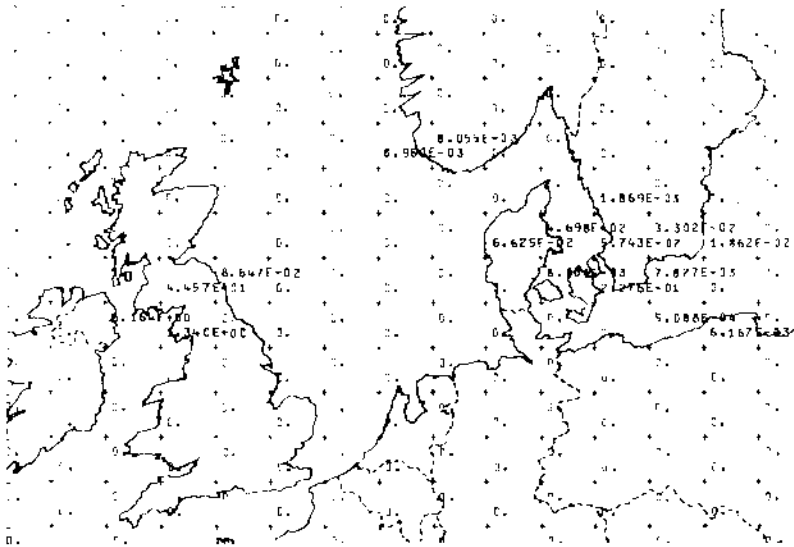

Figure 5. Population dose distribution due to inhalation for hypothetical 1 Ci, 6 hour release of  $^{131}\text{I}$  (man-rem in each grid square).



UNE MÉTHODE D'ÉVALUATION DES TRANSFERTS ATMOSPHÉRIQUES  
À GRANDES DISTANCES (100 - 1000 km)

J. Le Grand, A. Després  
Département de Protection - Service de Protection Sanitaire  
COMMISSIONARIAAT A L'ENERGIE ATOMIQUE  
B.P. 6 - 92260 FONTENAY AUX ROSES (FRANCE)

1. INTRODUCTION

Le but de ce travail est d'établir un modèle de transfert atmosphérique permettant l'évaluation de la concentration, sur l'ensemble du territoire français, qui résulte de rejets d'effluents gazeux d'une installation nucléaire.

2. DESCRIPTION DE LA MÉTHODE

2-1. Les données météorologiques

L'Office National de la Météorologie nous fournit le champ des vitesses de vent moyen entre les isobares 850 hPa et 1050 hPa, chaque jour à 0 h. et à 12 h., en 400 points extraits de la grille de prévisions météorologiques.

Cette grille, de pas constant, est tracée sur les cartes en projection métrigraphique utilisées par l'O.N.M. Elle est définie de la façon suivante :

- . Le pôle est un point de la grille,
- . Un des axes est parallèle au méridien  $10^{\circ}$  E,
- . La distance entre 2 points voisins est de  $190,5$  km sur le 60<sup>ème</sup> parallèle.

La partie de cette grille que nous utilisons est approximativement limitée par les méridiens  $20^{\circ}$  W et  $20^{\circ}$  E, et par les parallèles  $30^{\circ}$  N et  $60^{\circ}$  N.

Nous disposons d'autre part de la direction et de l'intensité du vent au point de rejet.

2-2. La méthode proprement dite

- . Le programme de calcul se déroule en deux temps :
  - . Détermination de l'axe de la trajectoire,
  - . Calcul de la diffusion.

2-2-1. Détermination de l'axe de la trajectoire

Hypothèses fondamentales :

- . Le rejet est continu ; son débit est constant.
- . Les conditions météorologiques (vitesse et direction du vent) restent constantes pendant 2 h.

Système de coordonnées utilisé :

- . L'origine des temps est la date du début du rejet.
- . Les abscisses et ordonnées des points sont repérées par rapport à la grille de l'O.N.M.

Le tracé d'une trajectoire se fait de la façon suivante :

Soit  $(X_r, Y_r)$  les coordonnées du point de rejet. L'émission commence au temps  $t_0 = 0$ . Les composantes du vent à la cheminée selon les 2 axes de référence sont alors  $U_r$  et  $V_r$  (en  $m.s^{-1}$ ).

Si cette situation est supposée constante pendant  $\delta$  h, l'axe du panache est arrivé, au temps  $t_0 + \delta$  au point de coordonnées :

$$X_1 = X_r + \delta \cdot U_r \cdot \frac{m}{U_r}$$

$$Y_1 = Y_r + \delta \cdot V_r \cdot \frac{m}{V_r}$$

$m$  est un facteur qui tient compte de la réformation des distances dans le système de projection utilisé ; il dépend de la latitude.

Le calcul de  $X_1$  et de  $Y_1$  se fait d'heure en heure, afin de tenir compte des variations de  $m$ .

Considérons maintenant que le champs des vents fourni par l'I.C.N.M. à la date  $t_0 + 12$  s'applique de  $t_0 + 6$  à  $t_0 + 18$ , et calculons les composantes du vent en  $(X_1, Y_1)$  par interpolation entre les points de la grille. Nous définissons ainsi un vecteur de vent au point  $(X_1, Y_1)$ , qui nous amène au point  $(X_2, Y_2)$  à la date  $t_0 + 18$ . Le calcul se poursuit jusqu'à ce que la trajectoire sorte de la grille.

## 2-2 Calcul de la diffusion

### a) Principes généraux

Si le débit est constant et la diffusion longitudinale négligeable, la concentration au sol peut s'exprimer par

$$\chi(X, Y, t) = \frac{q}{\pi \bar{u} \sigma_y \sigma_z} e^{-\frac{1}{2} \frac{y^2}{\sigma_y^2}} \quad [1]$$

Dans cette expression :

- .  $\chi(X, Y, t)$  est la concentration au sol ( $\text{Ci.m}^{-3}$ ).
  - .  $X$  et  $Y$  sont les coordonnées du point où on calcule la concentration.
  - .  $t$  est le temps mis par le polluant pour atteindre le point  $(X, Y)$ , exprimé en secondes.
  - .  $y$  est la distance du point  $(X, Y)$  à l'axe du panache (m).
  - .  $\bar{u}$  est la vitesse moyenne du vent ( $\text{m.s}^{-1}$ ).
  - .  $q$  est le débit du rejet ( $\text{Ci.s}^{-1}$ ).
  - .  $\sigma_y$  et  $\sigma_z$  sont les écarts-types de la distribution de la quantité  $q$  par rapport à sa localisation moyenne (m).
- Ils s'expriment par les relations suivantes :

$$\sigma_y = \left( A_y \frac{y}{\bar{u}} \right) \sqrt{K_y}$$

$$\sigma_z = \sqrt{2 K_z t}$$

- .  $t$  étant le temps de transfert, en secondes
- .  $A_y$  est le paramètre de diffusion horizontale
- .  $K_y$  est le coefficient de diffusion horizontale
- .  $K_z$  est le coefficient de diffusion verticale

Quand la diffusion verticale atteint la couche limite planétaire, située à l'altitude  $L$ , on suppose que la concentration peut s'exprimer par :

$$\chi(X, Y, t) = \frac{q}{\sqrt{2\pi} \sigma_y \bar{u} \sigma_z} e^{-\frac{y^2}{2\sigma_y^2}}$$

### b) Tracé du panache

Le panache est tracé de 12 h. en 12 h., en même temps que l'axe de la trajectoire. Il est limité à  $3\sigma_y$ , et calculé analytiquement.

### c) Définition de la grille sur laquelle sont calculées les concentrations ; termes correctifs

Les concentrations sont calculées pour les points situées à l'intérieur du panache, et dont les coordonnées, exprimées dans le système de la grille météorologique, figurent dans les données du programme de calcul.

Dans le cas où le polluant est un élément radioactif, la concentration ainsi calculée est modifiée par un terme de décroissance et de filiation.

De plus l'appauvrissement du nuage par dépôt sec est introduit sous la forme mathématique suivante :

$$e^{-2V_d \frac{\sqrt{t}}{\sqrt{\pi K_z}}} \quad [2]$$

Dans cette expression,  $V_d$  est la vitesse de dépôt, en  $\text{m.s}^{-1}$ .

d) Concentration intégrée sur le temps que dure le rejet :

$\chi_1(X, Y, t)$  est la concentration en un point de coordonnées  $(X, Y)$ . Les situations météorologiques sont supposées constantes durant 12 h.  
La concentration intégrée au point de coordonnées  $(X, Y)$ , en  $\text{Ci.h.m}^{-3}$  s'exprime donc par :

$$C(X, Y) = \sum_{i=1}^n x_i(X, Y, t) \cdot 1P$$

où n est le nombre de trajectoires tracées durant le temps du rejet.

### 3 - Brièvement de la méthode ; limites de validité

Les principales réserves que l'on peut porter sur la méthode utilisée concernant les points suivants :

- . Le raccordement des 2 systèmes de données météorologiques utilisés : on applique les données météorologiques du point de rejet pendant 6 h., puis on utilise les valeurs moyennes du vent fournies par l'O.N.M. Or l'écart type de la distribution n'atteint 1000 m (valeur limite qui lui a été fixée) qu'au bout d'une vingtaine d'heures.

- . On suppose que la hauteur de la couche d'inversion est constante, et fixée à 1000 m.

- . Il n'a pas été tenu compte des variations du relief.

### 4 - Exemple d'application

La mise au point du code de calcul a été faite en situant le rejet à Saclay. Les données météorologiques sont celles fournies par le pylône du C.E.A., à 10 m d'altitude.

Les données météorologiques fournies par l'O.N.M. couvrent la période du 12 au 17 décembre 1979, période de temps stable de vent d'Est.

Les données suivantes sont utilisées :

$$\begin{aligned} A_y &= 0,139, & K_y &= 1,13 & \text{pour } t < 9,7.10^4 \text{ s.} & & [1] \\ A_y &= 0,463, & K_y &= 1 & \text{pour } t > 9,7.10^4 \text{ s.} & & \\ L &= 1000 \text{ m} & K_z &= 5 \text{ m}^2 \cdot \text{s}^{-1}, & v_g &= 5.10^{-3} \text{ m s}^{-1} & [2] \end{aligned}$$

Les figures ci-dessous donnent, à titre d'illustration, 6 trajectoires numérotées dans l'ordre chronologique.

La seconde carte fournit les courbes d'isoconcentration qui résultent de l'ensemble des rejets, entre le 12 et le 13 décembre 1979, le débit du rejet à la cheminée étant arbitrairement fixé à  $1 \text{ Ci} \cdot \text{s}^{-1}$ .

Dans la réalisation de ce travail, l'appui et les conseils de Monsieur DOURY (C.E.A. DSM) et de Monsieur MONNET (C.E.A. SFR Saclay) ont été très utiles.

### REFERENCES

- [1] A. DOURY, R. GERARD, M. PICOT "Abaques d'Evaluation Directe des Transferts Atmosphériques d'Effluents Gazeux" CEA Rapport DSM n° 81, janvier 1976.
- [2] J.L. HEFFTER, A.D. CAYLOR "A Regional - Continental Scale Transport, Diffusion, and Deposition Model" Environmental Research Laboratories NOAA TM ERL ARL 50 juin 1975.

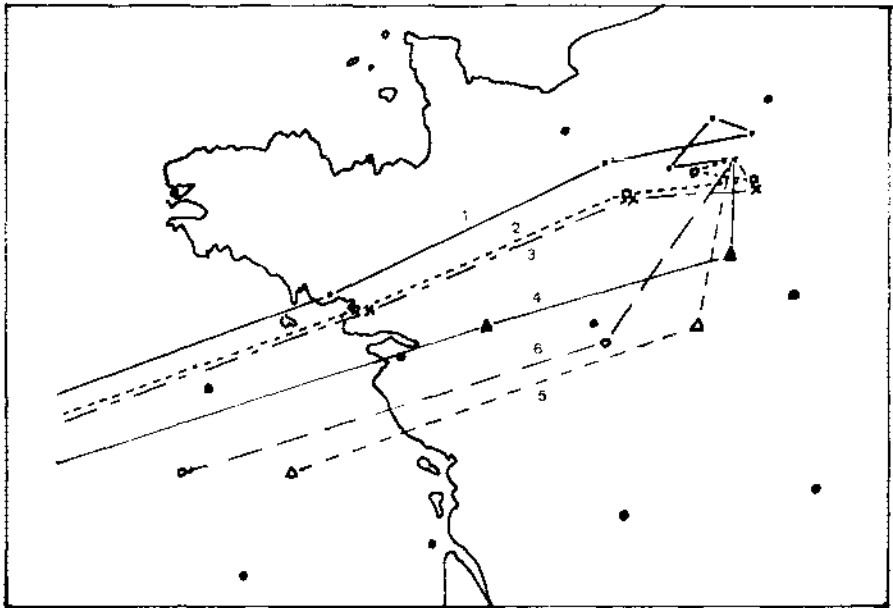

FIGURE 1. Exemples de trajectoires



FIGURE 2. Concentrations intégrées pour un rejet de 3 jours

## RELATIONSHIPS EXISTING BETWEEN TRITIUM RELEASES FROM DIFFERENT SOURCES AND THE CONTAMINATION OF AIR, WATER AND PLANTS

L.A. König, M. Winter and W. Tachlinski  
Nuclear Research Center Karlsruhe  
Health Physics Division

### 1. INTRODUCTION

Several thousands curies of tritium are released every year from the Karlsruhe Nuclear Research Center via the effluent air and water (1, 2). Therefore, it is obvious to investigate thoroughly the consequences of these releases. The liquid scintillation technique was chosen as the method of measurement. It offers the advantage that a great number of samples can be measured at relatively low expenditure. However, within the range of background concentrations, the accuracy of measurements is not very high, which is a drawback of this method. Nevertheless, it is adequate in this range to fulfill the main objective of these measurements, namely monitoring of the environmental radioactivity with a view to radiation protection.

### 2. TRITIUM EMISSIONS FROM THE KARLSRUHE NUCLEAR RESEARCH CENTER

Tritium is released to the atmosphere mainly via several exhaust stacks and it is almost exclusively in the form of tritiated water vapor. Different forms of tritium released have not yet been detected and are estimated to be insignificant. In the effluent water tritium from all sources in the Nuclear Research Center is discharged via the sewage treatment plant (3). Passing a 2.9 km long sewer, the liquid effluents reach the 'Altrhein', a former branch of the river Rhine and then they flow, mixed with surface water, over a distance of 23.6 km to be discharged into the river. Table 1 shows the tritium releases for the years 1975 and 1976 and the different emitters of the Nuclear Research Center as well as the heights of sources above the ground. In case that direct measurement is impossible, tritiated water vapor released to the atmosphere is measured by means of the liquid scintillation measurement technique on continuously condensed humidity samples of exhaust air (4).

### 3. MEASUREMENT PROGRAMS AND MEASUREMENT RESULTS

To be able to record contaminations of the environment caused by discharges, it was necessary to determine the present background due to fallout. A comprehensive measurement program serves this purpose, which covers essentially the region of the Upper Rhine Valley between Kehl and Mannheim. Details of this long-term program were reported recently in two publications (2, 5).

Diffusion of the tritiated water vapor released into the atmosphere can be calculated with a satisfactory accuracy. To determine the site specific parameters to be employed in the diffusion calculation (6, 7), diffusion experiments were carried out at the Karlsruhe Nuclear Research Center in which HTO and, subsequently, inactive chemical compounds had been used as the tracers (8-11). The most significant results of previous diffusion experiments has been that at a 100 m emission height the concentration maxima get considerably shifted toward the source as a result of surface roughness and that they are higher in amount than calculated with the help of the dispersion parameters used so far (6, 7).

To the extent of manpower availability, special measurement programs were performed the main results of which will be reported here. One example will be treated in more detail. The positions of the main tritium emitters and of sampling locations for the two programs described here are indicated in Fig. 1.

Emitter	Height of Emission in m	Tritium Release in Ci	
		1975	1976
FR 2 (44 MW <sub>th</sub> , D <sub>2</sub> O-moderated)	99	285	170
MZFR (200 MW <sub>th</sub> , D <sub>2</sub> O-moderated)	99.5	765	703
WAK (Reprocessing Plant, 40 t/a throughput, 3x10 <sup>4</sup> Mwd/t)	60	1300*	1000*
FERAB (incineration facility for solid radioactive wastes)	70	467	213
Decontamination plant for liquid wastes	19	53	73
Sewage treatment plant			
a) evaporations	0	~2**	~3**
b) liquid effluents	-	2821	4024
Several minor emitters	~10	5	20

Table 1 Tritium releases by the Karlsruhe Nuclear Research Center in 1975 and 1976.

\* authorized value

\*\* estimate based on average evaporation rate of 1 mm/d for an 800 m<sup>2</sup> uncovered surface

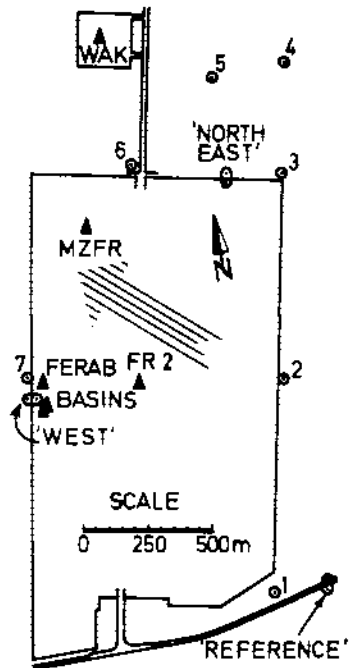

Fig. 1 Site plan indicating the main tritium emitters of the Karlsruhe Nuclear Research Center ▲ and the sampling locations covered by the initial program ○ and the follow-on program ⊙, respectively. → direction of ground water flow

### 3.1 Initial Program Covering Seven Sampling Locations at the Periphery of the Karlsruhe Nuclear Research Center

Within a measurement program limited in time the tritium concentration in the tissue water of plant samples was determined at seven sampling locations and at two of them also in the humidity of the air. The results have been summarized in Table 2. For the sake of clarity, only maximum and minimum values are indicated. Some of the individual values agree very well for samples of different types of plant taken at one sampling location, but partly they also show deviations by 30 - 50 % from each other. In very rare cases the ratios of concentration values are greater than the factor 2. According to expectations, the sampling location 1 yielded the lowest results because relative to the main emitters it lies outside the main wind directions. By contrast, clearly higher values were found at the sampling locations 3 to 6 whose positions relative to the emitters are in one of the two main wind directions. Last but not least, the highest values were measured at the sampling location 7 in the vicinity of the final basins of the sewage treatment plant.

### 3.2 Follow-on Program Covering Three Selected Sampling Locations

In another program limited in time the tritium concentrations were measured simultaneously at three sampling locations of pine (*pinus sylvestris*) and spruce (*picea abies*) needles, hornbeam (*carpinus betulus*) leaves, the humidity of the air, precipitations and of the ground water, if applicable. The samples were taken on working days only.

One sampling location lies in a region in which the ground water is contaminated (12). It is termed here sampling location 'West'. In the same region, also the humidity of the air is contaminated by the evaporation of chemical effluent water. The second location, termed 'North-east,' lies in the north-eastern part of the Karlsruhe Nuclear Research Center in the main wind direction relative to the tritium releasing FR 2 and MZFR reactors. At this point a back-

Sampling Location	Sampled Material	Tritium Concentration pCi/ml	
		maximum	minimum
1	grass	2.9	0.3
	foliage	2.3	0.6
	air humidity	1.6	0.1
2	foliage	3.5	0.7
3	foliage	17	0.8
4	foliage	10	0.8
5	grass	5.3	0.8
	foliage	7.8	0.7
	air humidity	7.9	0.6
6	foliage	3.2	1.0
7	grass	21	1.9
	foliage	29	1.5

Table 2 Results of simultaneous measurements of tritium concentration at seven selected sampling locations (18 samples each). The values were measured in the period from August 1 to September 23, 1975.

Sampling Location		Air Humidity pCi/ml	Precipitations		Ground Water pCi/ml	Needles pCi/ml		Foliage pCi/ml
			pCi/ml	ngi/m <sup>2</sup> /d		<i>pinus sylvestris</i>	<i>picea abies</i>	
Reference Location	Maximum	6.2±0.4 (2.8±0.3)*	3.5±0.3	25±2	0.59±0.17	3.0±0.3	2.8±0.3	1.8±0.2*
	Minimum	0.41±0.21 (0.2±0.2)*	0.2±0.2	0.07±0.02	< 0.15	1.0±0.2	0.84±0.20	0.88±0.17*
Sampling Location 'West'	Maximum	4.55±1.3 (4.7.4±1.5)*	48.8±0.5	124±4	576±16	61.5±1.9	45.2±1.4	70±2*
	Minimum	2.7±0.2 (4.1±0.3)*	1.5±0.2	0.56±0.10	37.6±2.2	13.1±0.6	2.5±0.3	15.2±0.6*
Sampling Location 'North-east'	Maximum	37.5±1.3 (5.4±0.5)*	4.5±0.3	27±2	not measured,	9.7±0.5	12.6±0.6	4.9±0.1*
	Minimum	0.5±0.2 (0.6±0.2)*	0.40±0.17	0.12±0.05	background expected	2.0±0.2	2.4±0.2	2.3±0.2*

Table 3 Results of simultaneous measurements of tritium concentration in air humidity, precipitations, ground water, foliage as well as in needles at selected sampling locations. The values were measured in the periods from March 3 to April 8, 1976 and from May 3 to May 26, 1976. The air humidity samples the measured values of which are given in parentheses, are taken at 15 m height above ground. The values marked by an asterisk refer only to May 1976.

ground level of tritium concentration has to be expected in the ground water. The third location, termed 'Reference', was so selected that it is exposed but rarely to the wind coming from the tritium emitters. Besides, it is opposed to the direction of ground water flow relative to the Nuclear Research Center.

The results of measurements have been compiled in Table 3. Again only the maximum and minimum values of tritium concentrations are indicated. In qualitative terms, the results correspond to that in Table 2.

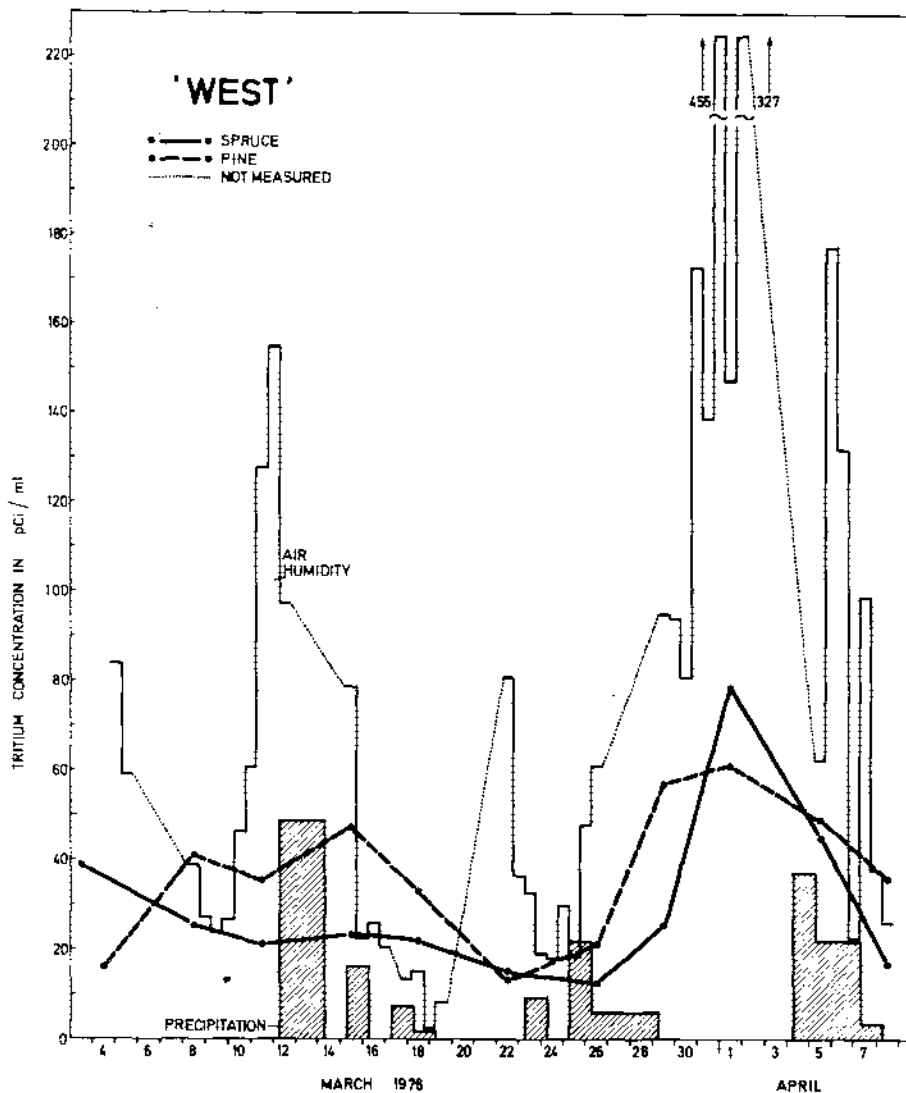

Fig. 2 Representation of the variation with time of the tritium concentration in spruces, pines, air humidity and precipitations, measured at the sampling location 'West' (see Fig. 1).



Fig. 2 shows the results obtained at the sampling location 'West' for the period from March 1 to April 7, 1976. The highest tritium concentrations were found at this sampling location. The results unambiguously show that the precipitation is not the main cause of tritium contamination of the needles. Since around the sampling location 'West' the ground water had been contaminated by about 400 pCi/ml of tritium within the period of reporting, both this contamination and that of the humidity of the air must be considered as causes of pine and spruce needle contamination. However, the rapid variations with time observed for the tritium contamination in tissue water, which correspond to that of the humidity of the air, indicate that the humidity of the air is one of the reasons of contamination.

Since the roots of pines extend to much lower depths than that of spruces, the contamination of the ground water should become apparent in differing tritium contaminations of the two types of needles. As a matter of fact, the expected differences can be observed. Due to the close vicinity of the final basins, where the tritium bearing effluent waters evaporate at ground level, the branches of spruces growing near the ground level (sampling height about 2 m) are exposed to higher tritium concentrations of the humidity of the air than the branches of pines beginning to grow at an about 12 m higher level. The fact that the higher tritium concentrations were generally found in pine needles also makes visible the influence of ground water contamination. However, the results measured in early April 1976 (see Fig. 2) likewise show that the contamination of spruces can be higher than that of pines in case of very high air humidity concentration near the ground level.

Fig. 3 shows the measured values for the sampling location 'North-east' applicable to the same time interval. As a result of tritium emissions from the exhaust stacks, the tritium concentrations of the humidity of the air are sometimes considerably enhanced, to which both types of needles are equally exposed. The ground water not contaminated at this place seems to dilute in this example the tritium concentration in pine needles.

At the so-called 'Reference' location neither the ground water is contaminated nor does a comparably high contamination of the air humidity prevail. For this reason, differing contaminations of pine and spruce needles have not to be expected here which is confirmed by Fig. 4. The observations made at the 'Reference' location do not allow a conclusion to be drawn relative to the path via which the needles measured had been contaminated.

The time plot of variations of the tritium concentration in tissue water allows to make conclusions with respect to the time constant and the half-life, respectively, which determines this plot. Both for pine needles and for spruce needles time constants and half-lives, respectively, of  $4 \pm 2$  d are found for the increase and reduction of the tritium concentration. The time sequence of measurement points and the experimental conditions were not sufficient to make a more accurate statement. In case of soil contamination by precipitation a slower reduction with time can be expected whereas rapid changes can be associated with the humidity of the air.

Besides the relationship existing between the tritium contaminations of the humidity of the air and of plants the relationship between the tritium emissions and the tritium contamination of the humidity of the air is also of some interest. In Fig. 5 the product of tritium emission rate and of the frequency of exposure to tritium from the individual emitters has been represented for the three sampling locations. The frequency is that at which the wind reaches the sampling location when it blows from an emitter. Since one day has been chosen as the unit of time, no high expectations should be made with respect to such a representation. Moreover, the diffusion category has not been

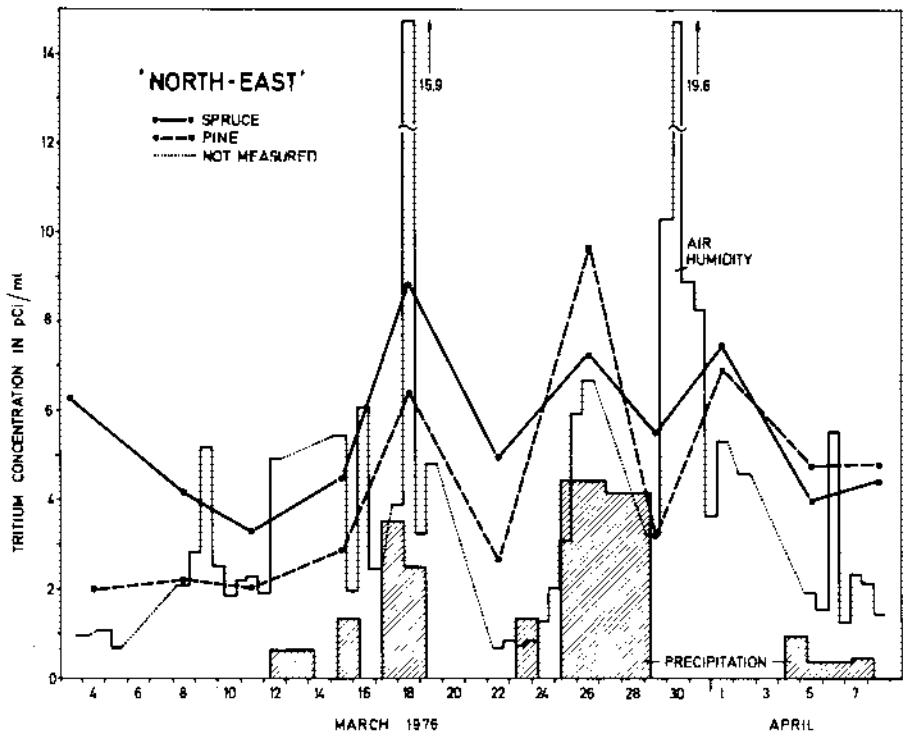

Fig. 3 Representation of the variation with time of the tritium concentration in spruces, pines, air humidity and precipitations, measured at the sampling location 'North-east' (see Fig. 1).

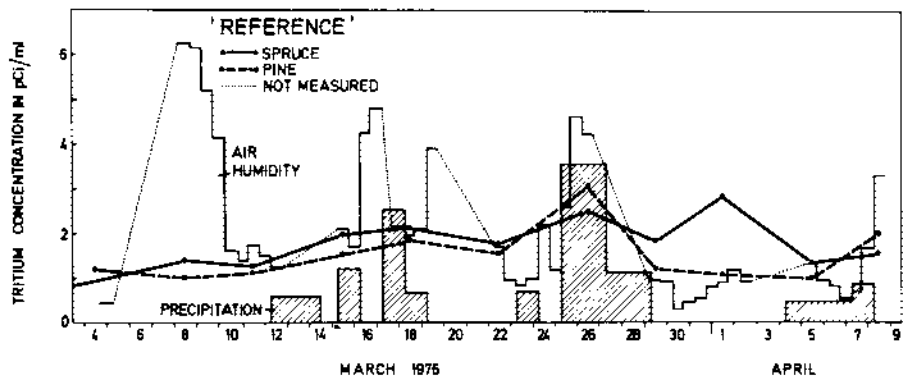

Fig. 4 Representation of the variation with time of the tritium concentration in spruces, pines, air humidity and precipitations, measured at the 'Reference' sampling location (see Fig. 1).

taken into account in this representation, which has a considerable influence on the concentration prevailing on the soil. Comparison of Fig. 5 with Figs. 2 to 4 shows that some peak values visible in Fig. 5 are matched by peak values found in the representations of the humidity of the air.

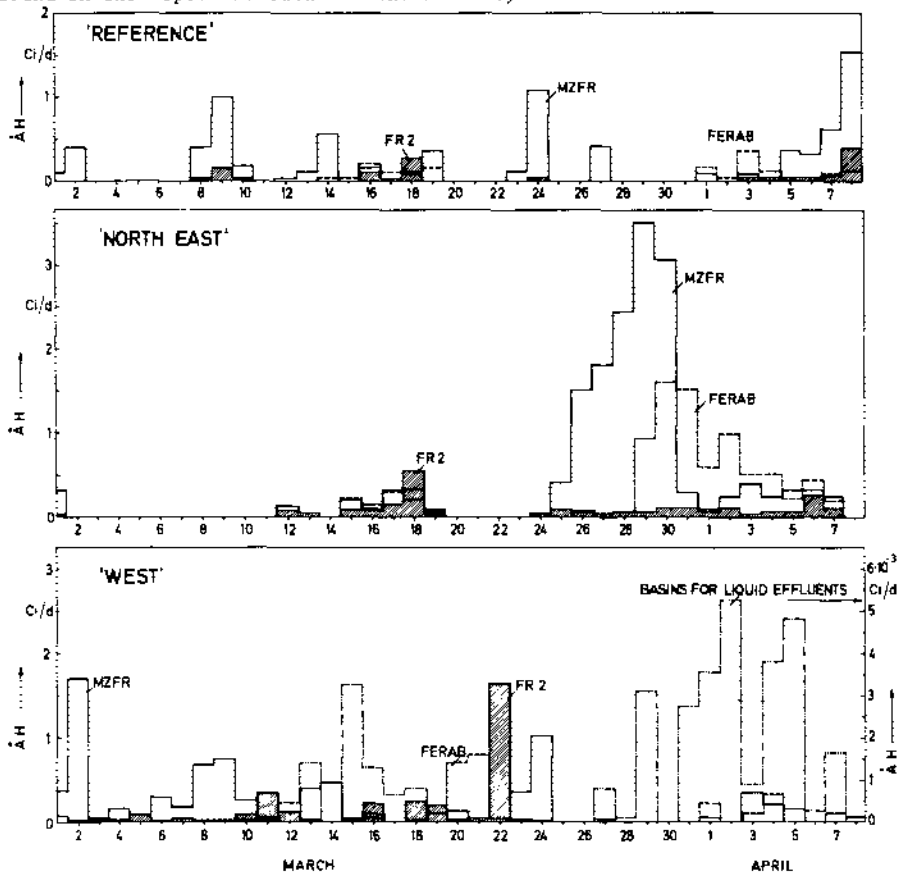

Fig. 5 Products formed of the tritium emission rate (A) of the main emitters of the Karlsruhe Nuclear Research Center and of the frequency (H) of those 10 minutes intervals on a day in which exposure of the sampling location under consideration was possible on account of the wind direction.

Also the days are of interest on which the sampling locations are not exposed at all to tritium from the emitters and yet tritium has been found in the humidity of the air. This has to be explained partly by contamination of the vegetation and the soil both of which release tritium by transpiration also on such days. The fact that a peak value of tritium concentration was observed in needles at the sampling location 'North-east' on March 26, 1976, without a corresponding peak value detected in the humidity of the air, is probably due to the fact that a peak value of tritium concentration in the air humidity was missed.

The difficulties in the evaluation of measured values are still increased by the dependency on height of the wind direction. Experience gathered at the site has shown that the wind direction can change substantially with the height and that eddies caused by buildings and vegetation essentially influence the diffusion of pollutants in the atmospheric layer near the

ground. So, the tritium concentration in the humidity of the air can be dependent on the height.

It can be concluded from results available so far that the tritium concentration of plants is largely determined by the tritium content of the humidity of the air. It has to be clarified by which path the tritium is taken up by the plants.

All tritium measurements reported here have been carried out in accordance with the Research Agreement No. 1302/CF concluded with the IAEA, Vienna.

#### REFERENCES

- (1) KÖNIG, L.A., WINTER, M., Contributions to the Annual Reports of the Health Physics Division (H. Kiefer, W. Koelzer, Editors): 1969: KFK 1158 (1970); 1970: KFK 1365 (1971); 1971: KFK 1565 (1972); 1972: KFK 1818 (1973); 1973: KFK 1973 (1974); 1974: KFK 2155 (1975); 1975: KFK 2266 (1976)
- (2) KÖNIG, L.A., WINTER, M., SCHÜLER, H., Tritium in Niederschlägen, Oberflächen-, Grund- und Trinkwasser - Ergebnisse eines Meßprogrammes mit Schwerpunkt im Raum Nordbaden in den Jahren 1971 bis 1974", KFK 2382 (November 1976)
- (3) WINTER, M., "Monitoring of Radioactive Liquid Effluents at the Karlsruhe Nuclear Research Center," OECD-NEA-Seminar on the Monitoring of Radioactive Effluents, Karlsruhe, May 14-17 (1974), AED-CONF-74-157-021
- (4) KÖNIG, L.A., WILHELM, J.G., DILLMANN, H.G., "Kontinuierliche Probenahme zum Nachweis von wassergebundenem Tritium," Atomwirtschaft-Atomtechnik 18, 582 (1973)  
"Continuous Sampling for Detection of Water Bound Tritium in Exhaust Air," OECD-NEA-Seminar on the Monitoring of Radioactive Effluents, Karlsruhe, May 14-17 (1974), AED-CONF-74-157-006
- (5) KÖNIG, L.A., WINTER, M., SCHÜLER, H., TACHLINSKI, W., "Investigation of the Tritium Level in the Environment of the Karlsruhe Nuclear Research Center," KFK-Ext. 20/76-1 (1976)
- (6) SLADE, D.H., Editor, Meteorology and Atomic Energy 1968, TID-24 190 (1968)
- (7) IAEA, Application of Meteorology to Safety at Nuclear Plants, Safety Series No. 29, Vienna (1968)
- (8) KIEFER, H., KÖNIG, L.A., WINTER, M., "Study of Propagation of Atmospheric Pollutants with Aid of Tritium," Kerntechnik 12, 212 (1970)
- (9) KÖNIG, L.A., WINTER, M., "Graphische Auswertung von Experimenten zur Bestimmung der atmosphärischen Ausbreitung mit tritiiertem Wasserdampf als Tracer," KFK 1667 (1972)
- (10) KÖNIG, L.A., NESTER, K., SCHÜTTELKOPF, H., WINTER, M., "Experiments Conducted at the Karlsruhe Nuclear Research Center to Determine Diffusion in the Atmosphere by Means of Various Tracers," Symposium on the Physical Behaviour of Radioactive Contaminants in the Atmosphere, Vienna, November 12-16 (1973)
- (11) THOMAS, P., HÜBSCHMANN, W., KÖNIG, L.A., SCHÜTTELKOPF, H., VOGT, S., WINTER, M., "Experimental Determination of the Atmospheric Dispersion Parameters over Rough Terrain, Part 1: Measurements at the Karlsruhe Nuclear Research Center," KFK 2285 (1976)
- (12) WINTER, M., KÖNIG, L.A., SCHÜLER, H., "A Case of Tritium Contamination of Ground Water," 4th International IRPA Congress, Paris, April 24-30 (1977)

A CASE OF TRITIUM CONTAMINATION OF GROUND WATER

M. Winter, L.A. König and H. Schüler  
 Nuclear Research Center Karlsruhe  
 Health Physics Division

At the end of August 1975 a conspicuous depression of the soil led to the detection of a leak in the piping system of the sewage treatment plant on the site of the Karlsruhe Nuclear Research Center (see Fig. 1). At the point where a plastic pipe penetrated into a concrete control pit a leakage was found about 3 m deep in the ground by which low level effluent water from laboratories, after having passed a decontamination facility, escaped into the soil, possibly over several weeks. The point of leakage lay between the storage basin of the sewage treatment plant and the so-called 'cyclator' (see Fig. 1) in which precipitations take place. After separation of the sewage sludge the clarified waste water reaches the final buffer basins and, eventually, the 'Altrhein,' a former branch of the river Rhine. The esca-

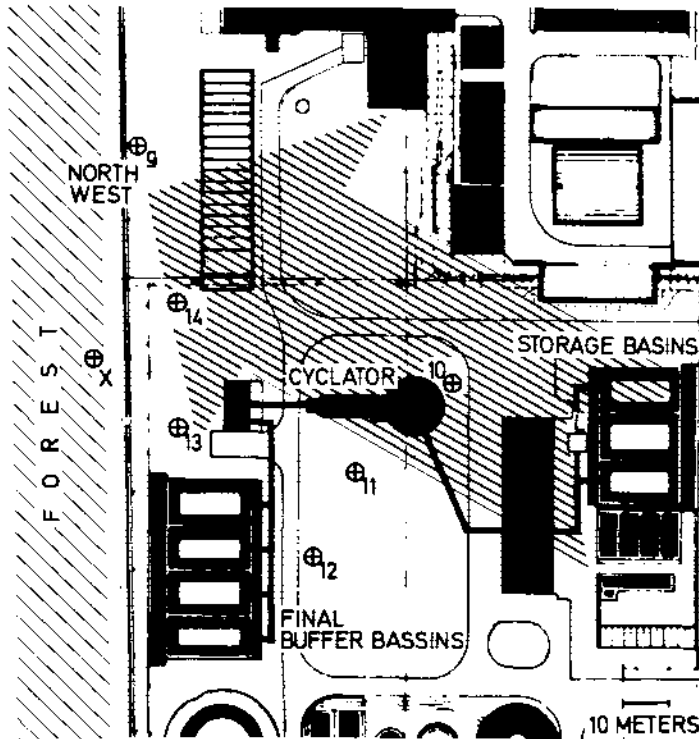

Fig. 1 Site plan of the sewage treatment plant of the Karlsruhe Nuclear Research Center.  
 □ L Point of leakage, ⊕ Locations of ground water drillings and index numbers.  
 ⇨ Ground water flow direction.

ping water was exclusively effluent water which had previously undergone a routine control of radioactivity. The total activity concentration of this effluent water (except for tritium) must not exceed the value of  $1 \times 10^{-4}$  Ci/m<sup>3</sup> according to the rules relating to the use of water applicable to the Karlsruhe Nuclear Research Center; the monthly average of tritium concentrations must not lead to surpassing of the maximum permissible concentration of  $3 \times 10^{-7}$  Ci/m<sup>3</sup> of effluent waters discharged into the main canal (1). On account of results of preceding regular control measurements an average tritium concentration of  $0.7 \times 10^{-7}$  Ci/m<sup>3</sup> (corresponding to 23 % of the maximum permissible concentration for tritium) had to be expected in addition to an insignificant total activity concentration (except for tritium) of about  $2 \times 10^{-7}$  Ci/m<sup>3</sup>. The point of leakage was immediately repaired after it had been uncovered.

The control authorities were informed about the incident. They requested that several ground water drillings were made on the premises of the sewage treatment plant (see Fig. 1) to be able to control the extent and diffusion of tritium contamination of the ground water.

According to geohydrological investigations performed in 1963 the ground water in the area of the Nuclear Research Center flows from south-east to north-west. The ground water level lies in about 4.7 m depth. Only the observation wells 10, 14 and g lie directly in the direction of ground water flow relative to the detected leakage point, namely at radial distances of 35 m, 100 m and 125 m. It should further be taken into account in this context that within the zone of the sewage treatment plant the established ground water flow direction had probably been changed locally in an unknown way due to the construction of buildings and on account of disturbances of the original strata of the soil caused by such construction work. The observation well marked x and located outside the Nuclear Research Center lies on the borderline of a wood and was set up as late as 8 months after the leakage had been detected, under a radioecological measurement program reported elsewhere at this meeting (2).

The variation with time of the tritium concentration of the ground water has been regularly observed since the setup of the seven observation wells and the sampling frequencies varied from several times a week to once a month. The results of these measurements have been represented graphically on a logarithmic scale (!) in Fig. 2 for the period from September 1975 to late December 1976. Investigations have shown a strong dependency of tritium concentration measured values on the pumping time preceding sampling. To get comparable results of measurements the ground water was raised for 10 minutes every time and subsequently discarded before samples were taken, which roughly corresponded to the time of occurrence of maximum concentration values.

Except for the well 12 immediately preceding the final basins and the well g located farthest to the north but almost exactly in the ground water flow direction relative to the leakage point, the tritium concentrations of wells exhibited a falling tendency from the beginning of investigations until the middle of 1976. However, it can be noticed that the tritium concentration of the well 10 is the only to decrease uniformly until the end of 1976. This allows the conclusion to be drawn that the well 10, after the leakage had been eliminated, shows an almost undisturbed decrease of tritium concentration in the ground water. Subsequently, the tritium concentration decreased until the middle of February 1976 first at a rate of about 40 nCi/1. day and then at a rate of only 0.3 nCi/1. day.

By contrast, the development of tritium concentration observed for the wells 11, 12, 13 and x, presents a much less uniform picture as from about May 1976 compared with the well 10. Also, the concentration values of the ground water

collected from the wells first named were practically always clearly higher in amount than the values measured at the well 10. In late 1976 the tritium concentrations at the wells 12, 13 and x exceeded by about the factor 3.5 the values measured at the well 10. The concentration at the well 11 was even higher by the factor 21.

This finding hardly allows another conclusion than that one or several un-tight or porous points in the system of the sewage treatment plant constitute permanent sources with small leakage rates from which little amounts of tritium are fed into the ground water again and again with the low level waste water, which superimpose on the reduction of contamination caused by the leakage in August 1975. This leakiness should be found in the 'cyclator' or in its feed pipes. This assumption allows a qualitative explanation of both the nearly constant rise in concentration observed at the wells 11, x, 13 and 14 in early August 1976, taking into account the location of wells relative to each other, and the absence of an impact on the well 10.

The development of the tritium concentration of the ground water from the well 12 does not fit into this picture and is difficult to explain. Considering the location of the leakage point and of the 'cyclator' as well as the direction of ground water flow, the assumption is suggested that an influence on the well 12 might also be exerted by the nearby final basins.

To allow a comparison with the concentration values reported here, Fig. 2 also shows the tritium concentrations of the uncontaminated ground water, which were almost exclusively inferior to the detection limit of 0.2 nCi/l (well 18, about 1.2 km south-east of the sewage treatment plant of the Karlsruhe Nuclear Research Center).

Fig. 3 shows for the same period as Fig. 2 the average weekly values of tritium concentrations of chemical effluent water collected in the final basins. However, since the throughput of effluent waters through the different stages of the sewage treatment plant is high (varying between 100 and 250 m<sup>3</sup>/h), it can be assumed that the tritium concentrations in the entire system of the sewage treatment plant differ but insignificantly at any moment. The plot of concentrations represented in Fig. 3 for the waste water treated does not provide a detailed explanation of the development of ground water contamination in the different wells since data are not available on a great number of influencing parameters. However, the tritium concentrations entered in Fig. 2 were lower by about the factor 100 in December 1976 than the corresponding average concentrations of the final basins (Fig.3).

Assuming that the maxima of plots represented in Fig. 2 for the well 10 (September 30, 1975), the well 14 (November 30, 1975) and the well g (January 25, 1976) represent the last direct influences of leakage, an average ground water flow velocity of some 1 m/day can be calculated, considering the different distances. The nearest drinking water station located approximately in the ground water flow direction is about 2.5 km away from the Nuclear Research Center. Even if it were situated in the very direction of ground water flow, it would take more than 6 years before a tritium contamination of the ground water from the Nuclear Research Center could produce any effect. A measurable impact is not to be expected because of the dilution taking place during ground water transport. Besides, the tritium concentration values reach only 50 % at the maximum of the limit value of the annual concentration mean, even in the area of the sewage treatment plant. This limit value is based on the ingestion limits stipulated in the Radiation Protection Ordinance of the Federal Republic of Germany, which will come into effect on April 1, 1977.

REFERENCES

- (1) WINTER, M., "Monitoring of Radioactive Liquid Effluents at the Karlsruhe Nuclear Research Center," Proc. OECD-NEA-Seminar on the Monitoring of the Radioactive Effluents, Karlsruhe, May 14-17 (1974), AED-CONF-74-157-021
- (2) KÖNIG, L.A., WINTER, M., TACHLINSKI, W., "Relationships Existing between Tritium Releases from Different Sources and the Contamination of Air, Water and Plants," 4th Intern. IRPA Congr., Paris, April 24-30 (1977)

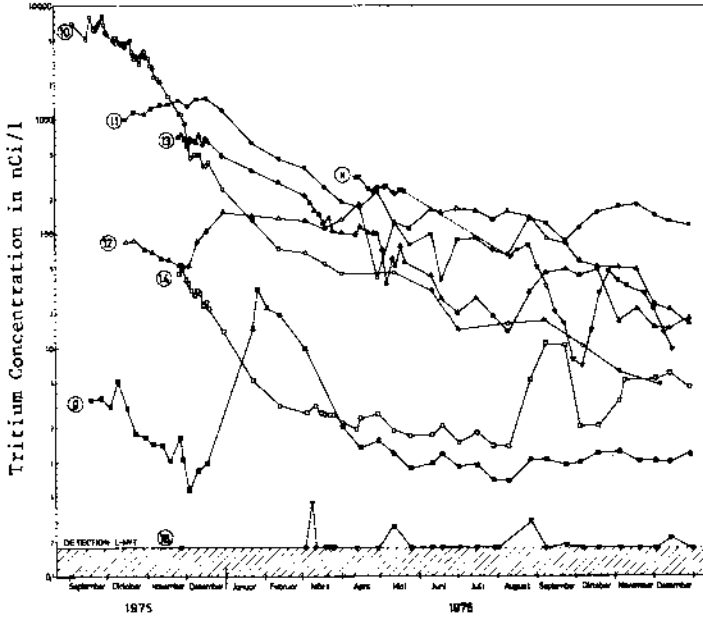

Fig. 2 Development of tritium concentration of the ground water in different observation wells in the vicinity of the sewage treatment plant.

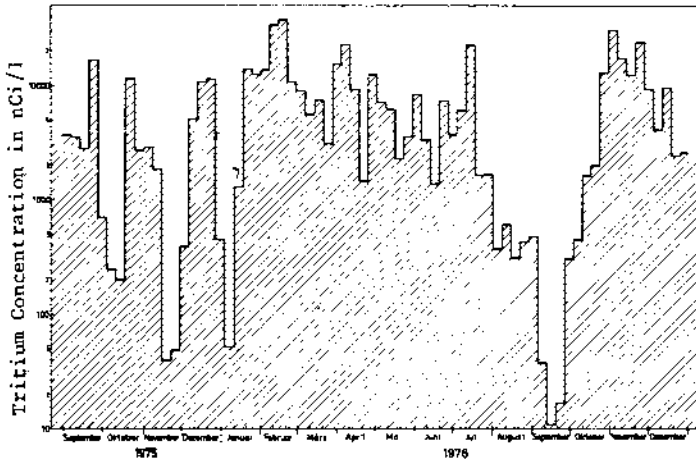

Fig. 3 Development of tritium concentration of the chemical effluent water in the final basins of the sewage treatment plant.



RAPPORT ENTRE LE COMPORTEMENT DU TRITIUM DES EAUX D'IRRIGATION DANS LES CULTURES ET L'EVALUATION DE LA DOSE RECUE PAR L'HOMME.

R. Kirchmann<sup>1</sup>, A. Grauby<sup>2</sup>, J. Delmas<sup>3</sup>, V. Athalye<sup>3</sup>, R. Van Bruwaene<sup>1</sup> et G. Koch<sup>1</sup>.

<sup>1</sup>Centre d'Etude de l'Energie Nucléaire, Mol, Belgium

<sup>2</sup>Centre d'Etude Nucléaire de Cadarache, France

<sup>3</sup>Boursier AGCD, Bhabha Atomic Research Center, Inde.

## 1. INTRODUCTION

Dans le cadre du programme de recherches sur le comportement du tritium dans l'environnement, coordonné par l'AIEA, des études expérimentales sur le transfert du tritium de l'eau d'irrigation à diverses espèces végétales cultivées, notamment aux parties comestibles, sont en cours. Les parcelles d'essais sont exploitées par des Centres de Recherche agronomique spécialisés et le CEN de Cadarache en ce qui concerne la région méditerranéenne et par le CEN de Mol en région de climat tempéré humide. En outre des expériences relatives au transfert du tritium du fourrage aux animaux de ferme sont également en cours.

Le but de la présente communication est de fournir une estimation des facteurs de dose associés à l'ingestion d'aliments provenant de végétaux cultivés ayant reçu un dépôt unique d'eau tritiée ayant une teneur standard de 1 nCi<sup>3</sup>H/l.

## 2. ORGANISATION DES EXPERIENCES ET RESULTATS

### 2.1. Expérimentation en région de climat tempéré humide.

Un champ d'essais, situé sur les terrains de la ferme expérimentale du département de Radiobiologie du CEN à Mol, a été divisé en 3 blocs de 7 parcelles (6 x 6 m<sup>2</sup>) chacun, parcelles destinées aux cultures suivantes: herbage mixte, ray-grass, pomme de terre, pois, orge, carotte et betterave sucrière. Les pratiques agricoles courantes de plantation, fumure et entretien ont été appliquées. Un volume de 100 l d'eau tritiée a été déposé en une fois, à un moment déterminé de la croissance, sur chacune des parcelles de 36 m<sup>2</sup> à l'aide d'un pulvérisateur à moteur, l'activité ainsi déposée a été de 1 mCi/m<sup>2</sup>. Des échantillons représentatifs d'organes de végétaux et de sols ont été prélevés à différents intervalles de temps, après l'application d'eau tritiée, les teneurs en tritium de l'eau et de la matière organique des échantillons ont été mesurées.

En outre des expériences de transfert du tritium des végétaux servant d'aliment à des animaux de ferme ont aussi été réalisées; c'est ainsi que trois porcs ont consommé des tubercules de pommes de terre tritiées par dépôt unique et trois vaches ont pâturé, en été, une prairie ayant reçu un dépôt unique d'eau tritiée. A l'abattage, des échantillons d'organes des porcs ont été prélevés et analysés; le lait de vache a été récolté et les teneurs en tritium de ses divers constituants ont été déterminées(1)(2).

## 2.2. Expérimentation en région de climat type méditerranéen

Les expériences en conditions naturelles ont été réalisées respectivement dans la plantation d'orangers du Centre de Recherche Agronomique INRA-IFAC à San Giuliano (Corse), dans le vignoble du Centre de Recherche Agronomique INRA du Languedoc et dans une plantation expérimentale d'olivier du CTGREP, en Provence. La méthode expérimentale appliquée dans les trois cas est la suivante : deux arbres sont choisis : le premier comme référence, le second comme sujet de contamination. L'eau tritiée contenue dans un réservoir a été répartie à l'aide de deux pulvérisateurs rotatifs localisés au sommet de l'arbre, le taux de pulvérisation étant de 7,5 mm/h. et la quantité déposée correspondait à environ 1 l/m<sup>2</sup>. Des échantillons de bois, feuillage et fruits ont été récoltés en vue de la détermination des teneurs en <sup>3</sup>H dans l'eau des tissus et dans la matière sèche; des échantillons de sol ont été prélevés à différentes profondeurs.

## 2.3. Résultats

Les niveaux de contamination des parties végétales comestibles sont indiqués dans le tableau 1. Quant aux produits d'animaux ayant consommé certains végétaux tritiés, les niveaux de contamination calculés sont respectivement: a) 1,05 pCi<sup>3</sup>H/kg de muscle et de foie de porcs ayant ingéré pendant 3 semaines 1 kg de tubercules de pommes de terre tritiées par un dépôt unique de 2,8 l/m<sup>2</sup> d'une solution à 1 nCi<sup>3</sup>H/l; b) 0,27 pCi/kg de lait produit par une vache pâturant une prairie contaminée par un dépôt unique de 0,25 l/m<sup>2</sup> d'une solution à 1 nCi<sup>3</sup>H/l.

Plante		Teneurs		
Espèce	organe ou constituant	pCi <sup>3</sup> H/ml eau dans tissus	pCi <sup>3</sup> H/g matière sèche	pCi <sup>3</sup> H/kg aliment frais
<b>A) Région tempérée humide</b>				
Pomme de terre	tubercule	6,4.10 <sup>-3</sup>	3,7.10 <sup>-3</sup>	5,7
Pois	grain	4,7.10 <sup>-4</sup>	7,0.10 <sup>-4</sup>	0,62
Orge	grain	8,7.10 <sup>-4</sup>	2,9.10 <sup>-3</sup>	2,60
Carotte	racine	1,2.10 <sup>-4</sup>	8,6.10 <sup>-4</sup>	0,20
Betterave	sucré		1,16.10 <sup>-3</sup>	1,16
<b>B) Région méditerranéenne</b>				
Vigne	vin			1,5.10 <sup>-2</sup>
Olivier	huile			0,7
Oranger	fruit			0,27

TABLEAU 1 Niveaux de contamination, au moment de la récolte de la partie comestible de végétaux ayant reçu une solution contenant 1 nCi<sup>3</sup>H/l à raison de 2,8 l/m<sup>2</sup> pour les végétaux de la région tempérée humide et de 1 l/m<sup>2</sup> pour les végétaux de la région méditerranéenne.

### 3. EVALUATION DE LA DOSE DELIVREE A UN INDIVIDU DE LA POPULATION CONSOMMANT LES PRODUITS VEGETAUX ET ANIMAUX TRITIEES.

Les valeurs de l'activité ingérée ainsi que celles du facteur de dose relatif à la voie de transfert considérée, c'est-à-dire une dépôt unique d'eau d'irrigation, sont mentionnées dans le tableau 2.

Aliment	Activité annuelle ingérée (pCi <sup>3</sup> H)	Dose urem/an	Facteur de dose $\frac{\mu\text{rem}/\text{an}}{\mu\text{Ci}/\text{ml}}$
<u>A) D'origine végétale</u>			
Tubercule (p.de terre)	5,7	$1,2 \cdot 10^{-3}$	1,2
Pois	0,6	$1,2 \cdot 10^{-4}$	$1,2 \cdot 10^{-1}$
Céréale (grain)	2,6	$5,4 \cdot 10^{-4}$	$5,4 \cdot 10^{-1}$
Carotte	0,2	$4,0 \cdot 10^{-5}$	$4,0 \cdot 10^{-2}$
Sucre	1,2	$2,5 \cdot 10^{-4}$	$2,5 \cdot 10^{-1}$
Vin	$1,5 \cdot 10^{-2}$	$3,1 \cdot 10^{-6}$	$3,1 \cdot 10^{-3}$
huile d'olive	0,7	$1,5 \cdot 10^{-4}$	$1,5 \cdot 10^{-1}$
Orange (chair)	0,3	$6,2 \cdot 10^{-5}$	$6,2 \cdot 10^{-2}$
<u>B) D'origine animale</u>			
Muscle et foie (porc)	1,0	$2,1 \cdot 10^{-4}$	$2,1 \cdot 10^{-1}$
Lait de vache	$2,7 \cdot 10^{-1}$	$5,6 \cdot 10^{-5}$	$5,6 \cdot 10^{-2}$

TABLEAU 2 Estimation de la dose délivrée à un individu de la population ingérant 1 kg d'aliment/an.

μ: teneur de l'eau d'irrigation (dépôt unique)

### 4. CONCLUSION

Ces résultats permettent d'évaluer le niveau de contamination de produits alimentaires à la suite d'un dépôt unique d'eau tritiée. Ce cas représente également la situation résultant d'une émission accidentelle dans l'atmosphère. Le dépôt sur la végétation, à la suite soit d'irrigations successives, soit d'émissions atmosphériques répétées, est aussi très important à considérer du point de vue de la contamination des produits alimentaires. Des essais sont en cours dans ce sens dans le cadre d'un contrat avec la Commission des Communautés Européennes.

### REFERENCES

- (1) KIRCHMANN R., CHARLES P., VAN BRUWAENE R., REMY J. and VAN DEN HOEK J. Distribution of tritium in the different organs of calves and pigs after ingestion of various tritiated feeds. Intern. Conf. on Molecular and Microdistribution of Radioisotopes and Biological Consequences. Jülich, 2-4 October 1975 (in press).
- (2) KIRCHMANN R., KOCH G., ADAM V. and VAN DEN HOEK J. Studies on the food chain contamination by tritium. In : Tritium, ed. by A.A. Moghissi and M.W. Carter. Messenger Graphics Publ., 341-348, 1973.

INTERNATIONALLY CO-ORDINATED RESEARCH IN RADIOECOLOGY AND  
ENVIRONMENTAL MONITORING

G.J. Köteles

Division of Nuclear Safety and Environmental Protection  
International Atomic Energy Agency A-1010 Vienna, Austria

1. INTRODUCTION

The projected growth of nuclear power in many Member States of the IAEA presents several questions of radiological protection which can best be resolved through international co-operation. In fulfillment of its statutory obligations the Agency tries to help in the development of soundly based radiation protection programmes relevant to the specific needs and circumstances of countries and regions. One approach is to co-ordinate investigations in individual Member States aimed at reliable assessment of radiation burden to the population from natural and man-made sources. The Agency's assistance, in addition to modest financial support of individual research groups, consists mainly of organizing meetings where the investigators and other experts can discuss research methods and evaluate and compare their data. In this way any undesirable overlapping of work can be avoided.

The basic principles of such co-ordinated research programmes are that a) the participation of a Member State is optional, b) the joint investigations must be based only on already existing relevant national programmes, c) the programme may possibly lead to technical, scientific or even legal agreements in which the recommendations of an international expert group will be reflected and incorporated into national regulations.

The present paper outlines briefly the main objectives and the ways of solving the problems in two current co-ordinated programmes "Studies on the Problems of Radioecology of the Danube River" and "Environmental Monitoring for Radiological Safety in South East Asia, the Far East and the Pacific".

2. THE DANUBE PROGRAMME

The protection of the water-related environment and the water quality is of common interest for the 8 states bordering the Danube, all of which are members of the IAEA. The main objectives of the programme are to investigate the radiological safety for the specific conditions of the Danube river, to harmonize measuring methods, and to evaluate the relationship between the possible releases of radioactive material into the catchment area and the radiation doses to the environment, the ecosystem and the human population both during normal operation of the existing or projected nuclear power stations and in cases of emergency (1). Figure 1 shows the Danube catchment area with the existing nuclear power stations and those projected for the next 6 years (1,2).

Joint investigations to date indicate that waste water from nuclear power stations of approximately 10,000 MWe capacity will enter the river. The distribution, however, of waste releases will be uneven, i.e. 60% and 75% respectively, will be released into the upper third and half of the river length. Taking into consideration international experience with BWR and PWR reactors (3), it can be foreseen that excluding H-3 95% of the total cumulative release value will enter the river in its upper third.

Some other findings of the programme are also of interest.

- Current measurements of the Danube water in various countries show 0.16 - 0.43 Bq/l (4.4 - 11.5 pCi/l) total beta activity (without K-40), 0.01 - 0.05 Bq/l (0.27 - 1.38 pCi/l) Sr-90, 0.002 - 0.05 Bq/l (0.05 - 1.46 pCi/l) Cs-137 and 11 - 33 Bq/l (300 - 790 pCi/l) H-3. Determination of the various radionuclides contributing to the gross radioactivity are now in progress.
- Rough estimates show that the cumulative concentration of mixed radionuclides forecast for the lower watercourse - even if absorption by the sediment is not taken into consideration - will be only 10 - 12% of the Maximum Permissible Concentration for members of the Public (MPCP of any mixture of radionuclides excluding Ra-226 and Ra-228 in drinking water is  $10^{-7}$  Ci/m<sup>3</sup>). The cumulative concentration of H-3 will be approximately 4 orders of magnitude lower than its MPCP value ( $3 \times 10^{-3}$  Ci/m<sup>3</sup>). These MPCP limits are defined in ref. 3.
- Concentration factors in various organisms have been determined, e.g. those for Co are in the range of 4000 - 12000 for algae, 1000 - 2000 for plants, 30 - 3000 for fishes. Extreme CF values for Co-60 however, in the order of  $10^5$  were measured in plankton. Great variations of the CF values in biota or in sediments are expected at various sectors of the river due to the differences of the flora and fauna whose composition is influenced by the hydroelectric stations. For example, there are clear indications that the construction of the Djerdap dam in Yugoslavia resulted in a more intensive accumulation of the radionuclides in the head-pond region than previously (1).
- A detailed bibliography of the relevant literature between 1957 and 1975 has been produced (4).

The future plans are based upon the recommendations of the programme advisory group (1) and may be modified on the basis of the results as they are obtained. Systematic measurements are now in progress for specific radionuclides in various inorganic and organic components of the river and its environment, and critical population groups and food-chains are being identified. A thorough intercomparison of the measured values will hopefully help an international monitoring network in the mutual interest of the riparian countries.

### 3. THE ENVIRONMENTAL MONITORING PROGRAMME IN ASIA

The Environmental monitoring serves as a verification system to demonstrate that controls on the releases of radioactive substances to the environment under normal conditions are functioning as intended and it also provides information on accidental release. One of the IAEA's important tasks is to give guidance on this subject to those Member States who are preparing nuclear power programmes (5). The aim of the South-East Asia programme is to promote investigations directed toward the identification of critical radionuclides and their transfer mechanisms through the characteristic local food-chains of the region. In addition, an assessment of the natural background radiation will also permit the evaluation of the radiation dose received by the local population. The work in which 7 countries (Bangladesh, India, Indonesia, Republic of Korea, Pakistan, Philippines and Thailand) are participating, is planned as a preparation for the growth of nuclear power generation in the region. The participation of the Federal Republic of Germany in this programme on the basis of a research agreement has made available to the other participants from South East Asia, the

Far East and the Pacific regions, wider experience in the planning and technical implementation of environmental monitoring programmes for nuclear facilities.

This international collaboration, besides providing a good forum for the exchange of experience in methodology and organizational questions, has already revealed some interesting features and data.

- Despite various levels of laboratory facilities and measuring methods comparable data could be obtained from several laboratories for total beta and gamma, Sr-90 and Cs-137 radioactivity measurements. 52 types of local food materials (vegetables, cereals, fruits, fish, meat) were analysed. Differences of radioactivity concentration in various varieties of certain items were identified (e.g. spinach and rice with a factor of 2 ~ 3 in gross beta and Cs-137 activity). Differences in gross beta and Cs-137 activities in rice samples were correlated with the different ash content in different varieties.
- Food consumption data were collected. After analyses and comparison of various food items the critical pathway to man for radionuclides proved to be cereals and sea-food in India for fishermen and farmers as critical groups near already existing nuclear centres as well as for the Philippine population.
- Where all necessary data were already available, the assessment of radiation dose from the incorporated radioisotopes through the food-chain indicated a yearly contribution of a few millirems to the annual total dose from the present level of radioactivity in a nuclear facility-free area.
- Further high background areas of natural external irradiation were identified in Bangladesh beach and Indonesian volcanic areas with maximum values of 1.14mC/kg/yr and 0.13mC/kg/yr (4400mR/yr and 500mR/yr), respectively.

#### 4. CONCLUSION

Future plans include the intercomparison of measured values in the region, and extended analysis of critical pathways and critical groups. These two examples point out the value of having such programmes coordinated by an international organization. The investigators are enabled to meet periodically to discuss the planning and implementation of the programmes, unintentional duplication of work is avoided, and more efficient use of resources can be assured. The provision of a discussion forum is not only valuable as a research-associated activity but also has significance in training and education. Many developing countries benefit too from the financial support, particularly for purchasing the proper equipment and materials. Finally, one of the most important characteristics of such collaboration is that a much wider international expertise from outside the region can be made available to the regional laboratories through the Agency's technical assistance programme. We believe that such co-ordinated programmes help to solve not only certain technical and scientific problems of environmental protection but also some national organizational and administrative problems of concern for multinational or regional cooperation.

#### REFERENCES

- (1) IAEA's Advisory Group to Study Questions of Mutual Cooperation between Countries in the Danube Catchment Area, Reports and Recommendations, AG-41, IAEA, Vienna, 1976
- (2) Power Reactors in Members States, IAEA, Vienna, 1976
- (3) Radioactive effluents from nuclear power stations in the Community, commission of the European Communities, V/1973/74, Luxembourg 1974.
- (4) Radosavljevic, R., Bibliographie über die wissenschaftliche Tätigkeit der Fachgruppe für Limnoradiologie - Internationale Arbeitsgemeinschaft Donauforschung - in den einzelnen Donauländern in der Periode 1957 - 1975. Belgrade, 1976
- (5) Objectives and Design of Environmental Monitoring Programmes for Radioactive Contaminants, Safety Series No. 41, IAEA, Vienna 1975.

THE DANUBE CATCHMENT AREA

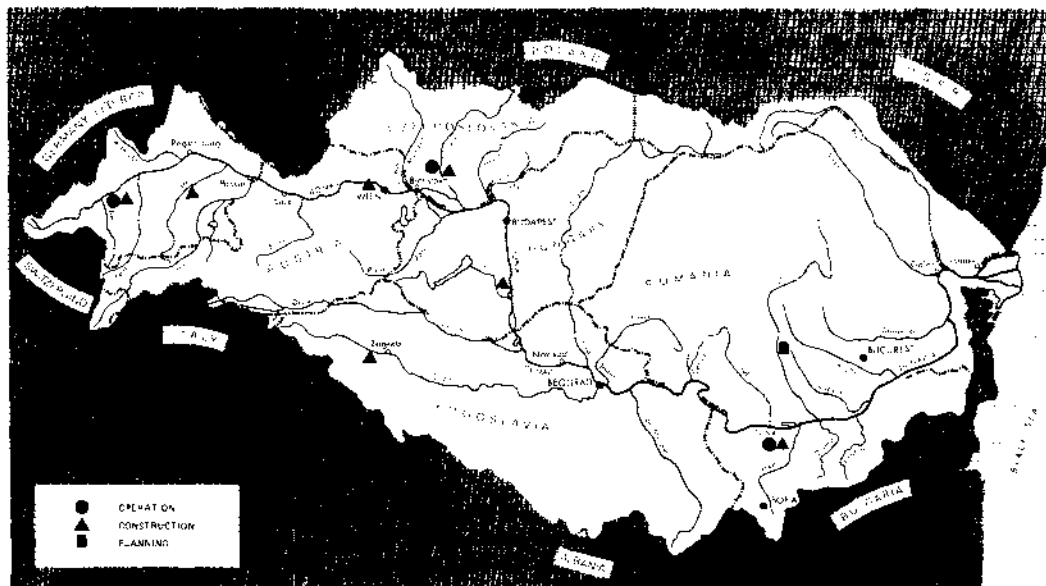

Figure 1.

CONTAMINATION DU LAIT EN  $^{90}\text{Sr}$  ET  $^{137}\text{Cs}$  RESULTANT DES  
RETOMBÉES ATMOSPHÉRIQUES : VARIATIONS RÉGIONALES DES  
COEFFICIENTS DE TRANSFERT

C. Madelmont, A. Bouville, R. Beckholz, E. Coulon  
Département de Protection - Service de Protection Sanitaire  
COMMISSARIAT A L'ÉNERGIE ATOMIQUE  
B.P. 6 - 92260 FONTENAY AUX ROSES (FRANCE)

### 1. INTRODUCTION

Cette publication se propose d'exposer les résultats d'un essai de généralisation de modèle de transfert du strontium 90 dans le lait proposé par R. COULON [1] dans le cadre d'une étude locale à un ensemble de régions productrices tout en étendant son application au césium 137.

### 2. MATÉRIELS ET MÉTHODES

Afin d'obtenir une bonne représentativité dans le temps et dans l'espace, chaque échantillon mensuel régional est constitué de cinq à dix sous-échantillons dont le volume tient compte de l'importance de la production laitière que chacun d'eux représente et qui sont constitués à partir d'une collection de prélèvements journaliers de lait de grand mélange.

La généralisation du modèle a consisté à calculer des facteurs de transfert régionaux qui minimisent les écarts entre les valeurs observées et les valeurs calculées. Pour certaines régions lorsque le suivi de l'évolution a commencé postérieurement à l'année 1965, il n'a pas été possible de déterminer le facteur de transfert relatif à la contamination directe par suite d'une trop grande imprécision.

Pour le césium 137, il a fallu utiliser comme valeurs observées les moyennes trimestrielles afin d'obtenir une solution générale acceptable (pour les valeurs mensuelles les modèles présentent une trop grande inertie).

Enfin, pour les deux radioéléments, les périodes de stabulation qui correspondent à une distribution de fourrage stocké, ont été écartées comme valeurs observées.

### 3. RESULTATS

L'expression générale du modèle est la suivante :

$$C_i = P \int_{p=i-1}^{p=\infty} R_p e^{-\lambda((i-1)-p)} + Pr_1 \int_{n=i}^{n=i-n'} R_n + Pr_2 \int_{m=i}^{m=i-m''} R_m$$

contamination indirecte
contamination directe
contamination semi directe

avec :

$C_i$  : contamination du lait exprimée en  $\mu\text{Ci/gCa}$  pour le  $^{90}\text{Sr}$  et en  $\mu\text{Ci/l}$  pour le  $^{137}\text{Cs}$  pour le mois (i) ou le trimestre (i)

R représente le dépôt humide en  $\text{mCi/km}^2$

$\lambda$  la constante de temps d'élimination des radioéléments dans le sol exprimée en  $\text{mois}^{-1}$  ou  $\text{trimestre}^{-1}$  et rapportée à l'année au tableau n° 1



Pd, Pr<sub>1</sub> et Pr<sub>2</sub> les facteurs de transfert relatifs à la contamination indirecte (sol), directe (plantes) et semi directe (base des tiges) exprimés en Bq/l de lait ou Bq/l de viande rapportés au mCi/cm<sup>2</sup>

$$\begin{aligned} \text{pour } ^{90}\text{Sr} \quad n' &= 1 \quad m' = 7 \quad m'' = 2 \\ \text{pour } ^{137}\text{Cs} \quad n' &= 0 \quad m' = m'' = 1 \end{aligned}$$

Le tableau n° 1 donne les expressions numériques de  $\lambda$ , Pr<sub>1</sub>, Pr<sub>2</sub> et Pd ainsi que le facteur de transfert global P<sub>23</sub> avec les périodes d'observation et l'expression du sigma.

#### 4. DISCUSSION

La justification de l'adoption d'un modèle de contamination à des conditions locales est illustrée par le tableau n° 2 qui donne, à titre d'exemple, la nature et les caractéristiques de la production fourragère de trois régions. On peut noter les différences très significatives qui existent d'une région à l'autre entre les productions sur sol en place (prairies permanentes) et les productions sur sol travaillé (prairies artificielles).

Les figures 1, 2 et 3 pour le césium 137, 4, 5 et 6 pour le strontium 90, donnent les valeurs observées (traits pointillés) et les valeurs calculées (traits pleins) pour les mêmes régions. On constate que le modèle est moins satisfaisant pour le césium 137 dont l'évolution des valeurs observées est beaucoup plus heurtée que pour le strontium 90. Comme il fallait s'y attendre, la contamination indirecte en pourcentage est plus importante pour le strontium 90 (partie noire de la représentation graphique attribuée au terme Pd) avec comme corollaire des pourcentages plus élevés pour le césium 137 pour ce qui incombe à Pr<sub>1</sub> (partie hachurée) et Pr<sub>2</sub> (partie non hachurée).

Dans une prochaine publication l'utilisation du modèle sera testée sur le plan prévisionnel (72 à 76) avec un essai d'interprétation du sens des variations de  $\lambda$ , Pd, Pr<sub>1</sub> et Pr<sub>2</sub> en fonction des facteurs pédologiques et agronomiques.

#### 5. CONCLUSION

Bien que la modélisation proposée pour le césium 137 soit moins satisfaisante que celle du strontium 90, la proposition d'un modèle trimestriel (<sup>137</sup>Cs) et mensuel (<sup>90</sup>Sr) semble plus opérationnelle pour résoudre certains problèmes d'environnement que des modèles annuels. Le fait d'adapter un modèle à des conditions locales qui peuvent être très contrastées paraît devoir être une méthode qui devrait être généralisée à tout processus de contamination.

#### BIBLIOGRAPHIE

- [1] R. COULON Dépôt de <sup>90</sup>Sr et contamination du lait. Proposition d'un modèle de transfert. 2nd International conference on strontium metabolism, Glasgow 16-19 Août 1972 CEA CONF 2126

#### REMERCIEMENTS

Les auteurs remercient J. BRENOT pour sa collaboration mathématique. Les mesures ont été faites par le Laboratoire de Radiotoxicologie - Service de Protection Sanitaire du Département de Protection CEN, Fontenay-aux-Roses. Les Services Vétérinaires Départementaux (Ministère de l'Agriculture) ont assuré la collecte des échantillons régionaux.

	VIENNE (usine)	GARONNE (régional)	BRESSE LYONNAIS (régional)	ANJOU VENDEE (régional)	NORMANDIE (régional)	SEINE MARITIME (usine)	CHARENTES (régional)	AISNE (usine)
$^{90}\text{Sr}$ (pCi/gCa)								
$\lambda$ an <sup>-1</sup>	0,12	0,10	0,14	0,08	0,12	0,16	0,12	0,20
Pd (1)	0,42	0,22	0,47	0,32	0,35	0,39	0,40	0,48
Pr <sub>1</sub> (1)	2,88	6,56	2,82	6,38	7,78	5,66	3,31	7,92
Pr <sub>2</sub> (1)	1,45	2,42	1,50	1,35	2,47	2,35	1,60	1,37
$\sigma^2$ (écart)	9,5	8,5	11,4	5,0	4,2	4,6	7,1	6,5
P <sub>23</sub> (1)	4,6	4,3	4,5	5,6	5,5	4,4	4,6	4,3
Période d'observation	62-71	63-72	64-72	64-72	64-72	60-72	63-72	61-72
$^{137}\text{Cs}$ (pCi/l)								
$\lambda$ an <sup>-1</sup>	1,50	2,75	2,00	0,70	2,25	2,00	2,75	1,20
Pd (1)	4,82	2,31	5,90	0,91	3,57	3,15	6,83	0,94
Pr <sub>1</sub> (1)	8,95	13,16	3,89	18,19	11,47	10,67	8,62	6,90
Pr <sub>2</sub> (1)	5,84	11,37	1,13	10,49	15,86	12,10	7,76	9,98
$\sigma^2$ (écart)	172,3	381,7	220,0	43,33	34,00	125,7	194,7	116,7
P <sub>23</sub> (1)	7,7	7,3	5,0	8,7	9,0	7,7	7,7	5,0
Période d'observation	62-71	63-72	64-72	64-72	64-72	60-72	63-72	61-72

(1)  $\mu\text{Ci}(\text{gCa})^{-1}$  par  $\text{mCi km}^{-2} \text{an}^{-1}$   $^{90}\text{Sr}$  et  $\text{pCi l}^{-1}$  par  $\text{mCi km}^{-2} \text{an}^{-1}$   $^{137}\text{Cs}$

TABLEAU N° 1 : VALEURS DES PARAMETRES : Pd (CONTAMINATION INDIRECTE), Pr<sub>1</sub> (CONTAMINATION DIRECTE) ET Pr<sub>2</sub> (CONTAMINATION SEMI DIRECTE)

	ANJOU - VENDEE			GARONNE			NORMANDIE		
	% Surf.	% Produc.	Rende- ment (1)	% Surf.	% Produc.	Rende- ment (1)	% Surf.	% Produc.	Rende- ment (1)
Surfaces toujours en herbe	50	43	38,9	60	37	20,5	86	81	50,5
Prairies artificielles	30	37	55,8	15	57	55,7	7	10	60,2
Maïs Fourrage	5	6	60,1	2	4	48,1	5	6	67,7
Autres fourrages verts	4	5	30,3	2	2	35,3	1	1	46,6
Betteraves	5	4	41,4	< 1	< 1	32,8	1	2	89,4
Autres plantes Sarclées	6	5	34,0	< 1	< 1	27,6	< 1	< 1	39,1

(1) Quintaux/hectare en matières sèches

TABLEAU N° 2 : NATURE ET CARACTERISTIQUES DE LA PRODUCTION FOURRAGERE

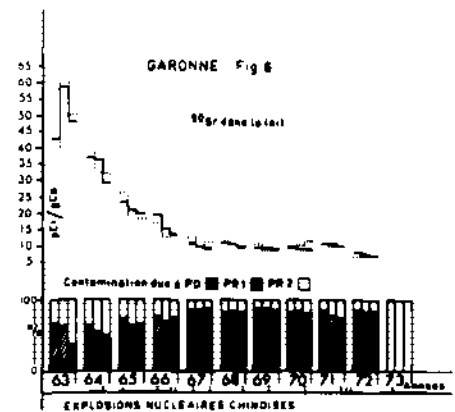
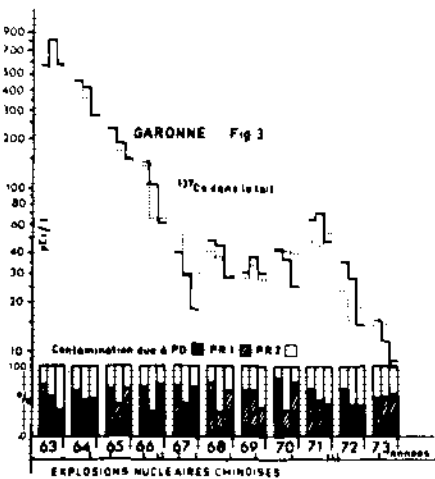
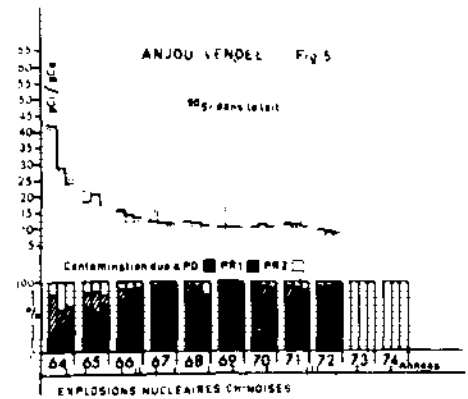
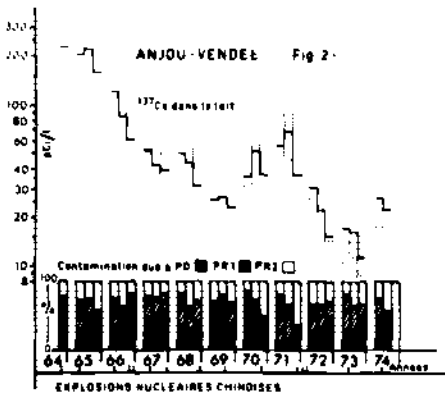
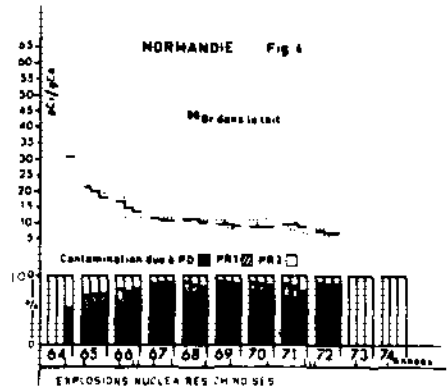
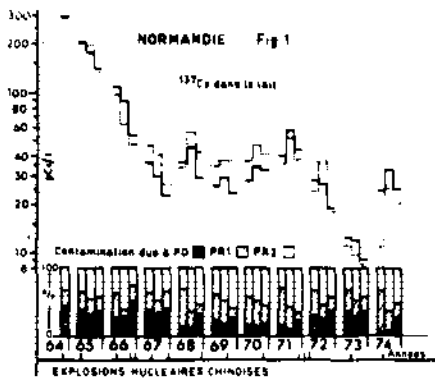

THE PREDICTION OF THE BEHAVIOR OF LONG-LIVED  
RADIOISOTOPES THROUGH A SATURATED SANDY LAYER

M. Fukui and K. Katsurayama  
Res. Reactor Inst. of Kyoto Univ.,  
Kumatori-cho Senri-gun Osaka-70, Japan (〒590-04)

## 1. INTRODUCTION

The phenomena of diffusion and dispersion of ions or molecules through porous media are found not only in engineering fields such as the process of ion exchange and filtration, but in natural hydro-system. Recently the pollution of subsurface water or lake and sea water due to industrial wastes has been discussed, and in the nuclear industry, there is a small, but a finite risk that long-lived radionuclides are released from their facilities and pollute the environment. So, it is important to predict the rate and range of movement of radionuclides in the ground or in the sediment.

This study was conducted to evaluate the mobility of many long-lived radionuclides through and in a sandy layer. In the study of diffusion phenomena in a sandy sediment, a new mathematical model with non-steady boundary condition was used, where one can easily obtain the values describing the mobility of radionuclides. In the study of miscible displacement, numerical analysis was attempted to demonstrate the applicability of theoretical model, which is the diffusion type equation coupled with nonlinear reaction models.

## 2. THEORETICAL

### 2.1. The Diffusion Phenomena in a Saturated Sandy Sediment

Eq.(1) is obtained by assuming that the rate of transfer of diffusing substance is proportional to the concentration gradient and the amount of diffusing substance in a porous element is conserved,

$$\frac{\partial C}{\partial t} = \frac{D_e}{p} \frac{\partial^2 C}{\partial z^2} - \frac{(1-p)\gamma \partial C}{\partial t} - \lambda C - \frac{(1-p)\gamma \lambda C}{p} \quad (1)$$

where  $C$  and  $Q$  are the concentration in liquid and solid phase,  $p$  is the porosity,  $\gamma$  is the soil density,  $D_e$  is the effective diffusion coefficient, and  $\lambda$  is the decay constant.

Assuming that the long-lived radionuclides are sorbed quickly once it is brought by diffusion into a soil and using the Henry isotherm,

$$Q = K_1 C \quad (2)$$

where  $K_1$  is the equilibrium coefficient.

By substituting Eq.(2) into Eqs.(1) and (1), the diffusion equation (1) is reduced into the standard form as Eq.(3),

$$\frac{\partial C}{\partial t} = \alpha \frac{\partial^2 C}{\partial z^2} - \lambda C \quad (3)$$

$$\text{defining : } \alpha = \frac{D_e}{p + (1-p)\gamma K_1} \quad (4)$$

$$\text{defining : } \alpha = D_e / [p + (1-p)\gamma K_1] \quad (5)$$

where  $\alpha$  is the apparent diffusion coefficient.

Assume that at time  $t=0$  the initial concentration in a soil is zero, and for all time  $t>0$ , the lower boundary concentration is zero when the length of the column is considered to tend to infinity. We assume furthermore that the amount of radionuclides which diffuses from the surface water into the soil for time  $t$ , is equal to that which decreases from the reservoir only, we obtain

$$H[C_0 - v(t)] = - \int_0^t De \cdot \frac{\partial w}{\partial z} \Big|_{z=0} dt \quad (6)$$

where  $C_0$  is the initial concentration in the reservoir and  $v(t)$  is at time  $t$ , and  $H$  is the depth of the surface water. Hence the solution of Eq.(1) subject to Eq.(6) and the boundary condition as described above is

$$\frac{C}{C_0} = \exp\left(\frac{De \cdot z}{\alpha H} + \frac{D \lambda^2 t}{\alpha H^2} \right) \operatorname{erfc}\left(\frac{z}{2\sqrt{\alpha t}} + \frac{De\sqrt{t}}{H\sqrt{\alpha}}\right) \quad (7)$$

Eq.(7) can be written as follows by substituting the dimensionless depth  $\xi$  and time  $\tau$  when the radionuclides are long-lived ( $\lambda = 0$ ),

$$\xi = De \cdot z / \alpha H \quad (8)$$

$$\tau = \sqrt{\alpha} / De \cdot t / H \quad (9)$$

$$C/C_0 = \exp(\xi + \tau^2) \cdot \operatorname{erfc}(\xi/2\tau + \tau) \quad (10)$$

## 2.2. The Models of Sorption and Transportation

The general mathematical equation that describes the material balance for diffusing substance during the miscible displacement through the saturated soil is written as

$$\frac{\partial C}{\partial t} + \frac{(1-\beta)\gamma}{\beta} \frac{\partial Q}{\partial t} = D \cdot \frac{\partial^2 C}{\partial x^2} - v \cdot \frac{\partial C}{\partial x} \quad (11)$$

where  $x$  is the distance along the direction of flow,  $D$  is the dispersion coefficient,  $v$  is the average pore velocity and other nomenclatures are mentioned previously. In this studies, the following sorption model was mainly chosen to evaluate the behavior of diffusing substances:

$$(a) \text{ } N^{\text{th}}\text{-order reaction type} \quad \partial Q / \partial t = k_1 C^N \quad (12)$$

$$(b) \text{ Lapidus and Amundson's type} \quad \partial Q / \partial t = k_2 (K_2 C - Q) \quad (13)$$

$$(c) \text{ Hiestor and Vermuelen's type} \quad \partial Q / \partial t = k_3^1 C (Q_0 - Q) - K_3 Q (C_0 - C) \quad (14)$$

$$(d) \text{ Lindstrom's type} \quad \partial Q / \partial t = K_4^1 C - K_5^1 Q \quad (15)$$

defining :  $f_1 = 1 - q/2$ ,  $f_2 = q/2$ ,

$$K_4^1 = k_4 \exp\left(-\frac{\Delta G_4^1 + \alpha' q}{RT}\right), \quad K_5^1 = k_5 \exp\left(-\frac{\Delta G_5^1 + (1-q)\alpha'}{RT}\right)$$

where  $k_1$ ,  $k_2$ ,  $k_3$ ,  $k_4$  and  $k_5$  are the adsorption or desorption rate constants,  $K_2$  and  $K_3$  are the equilibrium constants,  $f_1$  and  $f_2$  are the sticking and desorption probability,  $\Delta G_4^1$  and  $\Delta G_5^1$  are the free energies of activation required for adsorption and desorption,  $\alpha'$  is the energy stress constant,  $q$  is the fraction sorbed ( $0 < q < 1$ ) and  $R$  is the gas constant.

Eqs.(2) and (13) have been often used to examine the sorption model, but the exact solutions for Eqs.(12),(14) and (15) which are coupled with Eq.(11) are not obtained analytically, owing to the nonlinearity. We attempted to solve these coupled nonlinear equations by using the finite difference method with the quasilinearization technique, where the difference expressions of modified Crank and Nicolson were used. The procedures of analytical method are not described here owing to its occupying the majority of this paper.

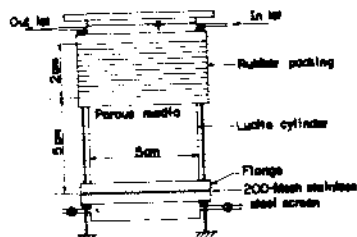

Fig.1 Schematic Diagram of the Diffusion Experimental Set Up

### 3. EXPERIMENTAL

#### 3.1. The Diffusion Experiment

**Equipment** — The apparatus for this study consists of a packed bed as shown in Fig.1. To minimize penetration of the bulk convective flow into a soil, the surface water was circulated airtightly by tube pump, which could regulated the velocity and prevent the change of pH, instead of using the stirrer.

**Soil** — All experiments were carried out on Toyoura fine quartz sand. The mechanical analysis of this soil was :

sand - - - 99 % and silt - - - 1 %

The cation exchange capacity was about 0.5 meq/100 g.

**Diffusing substances** — The radionuclides used were  $^{54}\text{Mn}$ ,  $^{85}\text{Sr}$ ,  $^{60}\text{Co}$ ,  $^{137}\text{Cs}$ ,  $^{90}\text{Sr}$ ,  $^{131}\text{I}$ ,  $^{90}\text{Y}$ ,  $^{137}\text{Cs}$  and  $^{144}\text{Ce}$  etc.. These were mixed with 1 mM  $\text{CaCl}_2$  solution and pH was adjusted to 4 and 7 respectively. The diffusion experiments were conducted under the chemical concentration of stable isotopes ranging  $10^{-3}$  to  $10^{-4}$   $\mu\text{g/ml}$ .

**Diffusion experimental procedure** — At first, the solution which contains diffusing substance is fed from the reservoir (100 or 200 ml) by tube pump, then the 5 ml solution in it was sometimes sampled and the concentration change was measured by 4K PHA with 58.5 cc  $\text{Ge(Li)}$  detector. After a run of the diffusion experiment, the equipment was disjoined carefully and the packed material was taken as the rubber packing was sliced off. Then the section distributions in a sandy layer were measured.

#### 3.2. Miscible Displacement Experiment

**Soil** — The same packing of Toyoura fine quartz sand as mentioned above was used. The soil was air dried and then passed through a 2.0 mm sieve. The soil of 100 g was carefully packed into lucite columns filled with 1 mM  $\text{CaCl}_2$  to an approximate bulk density of  $1.46 \text{ g/cm}^3$ , where one pore volume (PV) was 26.4 ml.

**Diffusing substances** — The radionuclides used for the miscible displacement were  $^{35}\text{S}(\text{SO}_4^{2-})$ ,  $^{32}\text{P}(\text{PO}_4^{3-})$ ,  $^{36}\text{Cl}(\text{Cl}^-)$ ,  $^{131}\text{I}(\text{I}^-)$  and the same as described in 3.1..

**Equipment** — The column of 2.3 cm I.D.(Internal dia.) and 22 cm long was vertically oriented where it had a 200-mesh stainless steel screen to hold the soil at their base, the inlet pipe and drainage pipe under the base to allow the inflow solution to be changed quickly. The packed soil is initially treated with 1 mM  $\text{CaCl}_2$  introduced to the bottom inlet by a constant volume tube pump, where the solution flows upwards. When a predetermined amount of a tracer slug and successively that of 1 mM  $\text{CaCl}_2$  were added to the columns, the flow was terminated and the saturated soil samples were extracted from the outlet as sectioned to 2 cm intervals along the soil columns. The samples were air dried and the distribution of  $\gamma$ -emitters sorbed on soil were analyzed by using 4K PHA with  $\text{Ge(Li)}$  detector. The behaviors of the radioactive anions was mainly examined by obtaining the breakthrough curves where the radioactivities were measured by using a liquid scintillation technique.

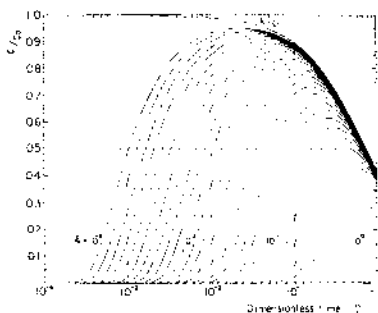

Fig.2 Theoretical Curves of the Concentration in Interstitial Water at Depth

## 4. RESULTS AND DISCUSSION

### 4.1. The Apparent Diffusion Coefficients

Fig.2 shows the concentration history computed for various depth  $\xi$ . The apparent diffusion coefficients are obtained from the theoretical curve of  $\xi=0$  and the observed concentration of surface water. The values of apparent diffusion coefficient were approximately obtained for Toyoura fine quartz sand as follows,

$$\begin{aligned} & (3 \sim 4) \times 10^7 \text{ cm}^2/\text{sec for Sr,} \\ & (1 \sim 2) \times 10^7 \text{ cm}^2/\text{sec for Mn, and} \\ & (3 \sim 8) \times 10^8 \text{ cm}^2/\text{sec for Cd, Co and Zn.} \end{aligned}$$

The validity of this model with non-steady boundary condition, which could determine this coefficient easily, was examined by observing the sorption distribution in the sandy layer.

### 4.2. Miscible Displacement

The sorption of inorganic anions to Toyoura fine quartz sand was examined by using the miscible displacement technique, where the tracer is introduced rectangularly to the soil column and successively leached with 1 mM  $\text{CaCl}_2$  solution or deionized water. The adsorption of  $\text{Cl}^-$  on the soil was weak but  $\text{SO}_4^{2-}$  and  $\text{PO}_4^{3-}$  were adsorbed extremely. The breakthrough curve of  $\text{SO}_4^{2-}$  for Ca-saturated sand was similar to that of cations, though  $\text{SO}_4^{2-}$  was leached with deionized water. This means that the sorption phenomenon is based not on ion exchange but a chemical reaction on the solid phase. The adsorbed ion of  $\text{PO}_4^{3-}$  on the soil was not leached with 1 mM  $\text{CaCl}_2$  solution and distilled water. This irreversible phenomenon stems from that the insoluble ion pairs are formed in soil solution and these colloidal particles or precipitates are retained mainly by its filtering action. Iodine in solution consists of two soluble forms, one is non-reactive to the soil and another being sorbed tightly. Thus, the behaviors of radioactive anions are affected by various types of reactions, though they were not based on the ion exchange.

In this paper, we do not refer to the exact results of the finite difference approximation as to the sorption models coupled with the transportation model. Under acid condition ( $\text{pH} < 4$ ), the divalent cations adsorbed are readily leached by the acid dissociation action, where the composition would shift as they move downward, and it is difficult to predict their movement. At higher levels of the pH (4 to 7), the divalent cations as  $^{85}\text{Sr}$ ,  $^{54}\text{Mn}$  and  $^{60}\text{Co}$  behave only as exchangeable cations and their concentration in soil water would be described by one of the sorption model of Eqs.(2), (4) and (5).

The behaviors of radionuclides depend on not only pH but also their concentration. Particularly, the Cs moves faster, as the concentration of the slug increases.

Fig.3 shows the breakthrough curves when four kinds of Cs concentration slugs of 10 T are introduced into the column, and successively leached with 1 mM  $\text{CaCl}_2$  of 25 T.

In this figure, the predictions were carried out by using the coupled models of Eqs.(11), (14) and Langmuir type equation.

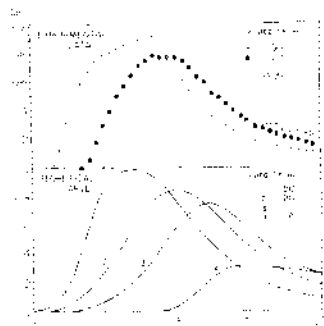

Fig.3 Experimental and Theoretical Breakthrough Curves of Cs ion

STUDIES ON RADIOECOLOGICAL CONCENTRATION PROCESSES IN THE AQUATIC ENVIRONMENTS  
-UPTAKE AND RETENTION OF Am-241 BY FISH-

Y. Nishiwaki\*

Atomic Energy Research Institute, Kinki University, Higashi-Osaka City, Osaka, Japan .

\* At present at the International Atomic Energy Agency, Vienna, Austria

Y. Kimura and Y. Honda

Department of Nuclear Reactor Engineering, Faculty of Science and Technology, Kinki University, Higashi-Osaka City, Osaka, Japan

M. Sakanoue and A. Kobayashi

Radiochemical Laboratory, Faculty of Science, Kanazawa University, Kanazawa City, Ishikawa, Japan

## 1. INTRODUCTION

Much attention has been paid for the environmental contamination with transuranics, especially plutonium having long half-lives and high radio-toxicity, from nuclear installations or weapon testing. On the other hand, recently, the environmental concern for americium has increased from the radiological protection point of view (1). However, only limited knowledge has been obtained on the behavior of americium in the aquatic environments (2-6). To elucidate radioecological concentration processes of americium by aquatic organisms, the uptake and retention of Am-241 by fingerlings of rainbow trout were investigated under laboratory conditions using natural river water with aeration. The results were compared with those of some other radionuclides such as Co-60, Ru-106, I-131, Cs-137 and Ce-144, in relation to their physical states.

## 2. MATERIALS AND METHODS

### 2.1. Radionuclides

Am-241 in  $\text{Am}(\text{NO}_3)_3$ , Co-60 in  $\text{CoCl}_2$ , I-131 in NaI, Cs-137 in CsCl, Ce-144 in  $\text{CeCl}_3$ , Ru-106 in chloro and RuNO complexes of RuNO-nitro, -nitrate and -binuclear which were prepared according to the method described by Fletcher et al. (7) and were used in the present experiments.

### 2.2. Fish and their rearing method

The fingerlings of rainbow trout, *Salmo gairdneri irideus*, were about 5 months old after hatching. The average body length and weight of the fish were 5 cm and 1 g, respectively. The fish were reared with aeration in plastic vessels which held 20 liters of a river water of pH 7.2 contaminated with each radionuclide at the radioactive concentration of about 1-10  $\mu\text{Ci/l}$ . The temperature of rearing water was kept at  $12 \pm 1^\circ \text{C}$ . The fish were transferred to the vessels in a group of about 200 fish when the radioactive concentration of the rearing water reached at an approximate constant level. During retention experiments, the rearing water was frequently changed for the fresh one without radioactivity to prevent a buildup of contaminants. Throughout the experimental periods, the fish were reared without specific feeding.

### 2.3. Fractionation of radionuclide in rearing water

To elucidate physical states of radionuclides in rearing waters, the fractionation experiments of the radionuclides were carried out by filtrating 5 ml of rearing water with Millipore HAWP filters (0.45  $\mu\text{m}$  of pore size).



The filters which retained Am-241 were also observed by the alpha-track autoradiography using cellulose nitrate film detectors.

#### 2.4. Measurement of radioactivity

The individual fresh sample made up in triplicate was measured for its radioactivity by using automatic gamma counting system equipped with well type NaI(Tl) detector (Auto-well). The Am-241 concentration in samples was also measured by using low energy photon spectrometer (LEPS). Furthermore, the alpha-track autoradiograms were taken with frozen sections of fish.

### 3. RESULTS AND DISCUSSION

#### 3.1. Fractionation of Am-241 in rearing water

The changes of Am-241 concentration in rearing water are shown in Fig. 1 with the alpha-track autoradiograms of filters retaining Am-241. The results obtained by both Auto-well and LEPS counting showed quite similar trend with each other. The radioactivity of Am-241 retained on filters increased with time after transfer of fish into the water and reached to an apparent equilibrium state in about 5 days. The fractionation of the radionuclides in rearing waters showed that at apparent equilibrium states, about 90% of Am-241 were retained on the filters in the same way as Ce-144, while only about 20% was retained for RuNO-nitrate and less than 10% for the other radionuclides. These results indicate that more than 50% of Am-241 or Ce-144 and some of Ru-106 in fresh water are of particulate form, while most of Ce-60, I-131 and Cs-137 are of quite soluble form as previously reported (8). Am-241 should behave in a similar way to the lanthanide elements in the marine environment in many respects (4). In the present studies, Am-241 also behaved in a similar way to cerium in the fresh water environment. As can be seen from the plate in Fig.1, the alpha-track autoradiograms of the filters retaining Am-241 showed homogeneous tracks before transfer of fish into the water, while aggregations observed after transfer of fish seemed to indicate adsorption of Am-241 on suspended matter. Murray and Fukai (9) reported that most of Am(III) in the filtered War River water of pH 8.1 was in particle form and the particle formation of Am(III) in both river water and sea water seemed to be influenced much more than that of Pu(IV) by the occurrence of unfiltered substances.

#### 3.2. Uptake and retention of Am-241 by fish

The uptake and accumulation of Am-241 in the whole-body of fingerlings are shown in Fig. 2 with those by their tissues of viscera and gills. The curves were drawn on the basis of assumed exponential model (10). The pattern of whole-body uptake of Am-241 was similar to that of Ce-144 and radioactivities in the fish reached apparent equilibrium in about 10 days, whereas only several days were required for the other radionuclides (11). Table 1 summarizes the rate of uptake (u) and the turnover rate (3) calculated from the uptake curves on the basis of exponential model (10). The concentration factors are also listed in this table, though the concentration factor of Am-241 for lake trout in the Lake Michigan was not explicitly reported by Wahlgren et al. (5). As can be seen in this table, the estimated concentration factors from the ratio  $u/B$  are quite similar to those observed.

It is noticeable that the highest uptake of Am-241 were found in the viscera including digestive tracts and was followed by that in gills. The alpha-track autoradiograms of frozen section of fish also demonstrated the occurrences of aggregated Am-241 in the digestive tracts.

These results suggest that the fish swallowed suspended matters, on which Am-241 was adsorbed. On the other hand, the highest uptakes among various tissues were found in viscera for Ru-106, Ce-144 and Co-60, in gills for I-131 and in muscle for Cs-137 (11-12).

The retention patterns of Am-241 by whole-body, viscera and gills are shown in Fig. 3.

The whole-body retention of Am-241 was about 30% in 10 days and thereafter gradually decreased. The elimination of Am-241 from the tissues was highest in gills. Comparing the retention in 20 days, only about 9% of whole-body was found for gills, whereas about 63% for viscera including digestive tracts. This higher retention of Am-241 in viscera was similar to the previously reported value for Ce-144 (11).

#### REFERENCES

- (1) ELLETT, W.H., et al., Allowed health risk for plutonium and americium standards as compared with standards for penetrating radiation, In "Transuranium Nuclides in the Environment", 587 (IAEA-SM-199/113), IAEA, Vienna (1975)
- (2) EMERY, R.M., et al., Ecological behavior of plutonium and americium in a fresh water ecosystem, Phase I. Limnological characterization and isotopic distribution, BNWL-1867 (1974)
- (3) EMERY, R.M., et al., Ecological behavior of plutonium and americium in a fresh water ecosystem, Phase II. Implications of differences in transuranic isotopic ratios, BNWL-1879 (1974)
- (4) NEVISSI, A., et al., Distribution of plutonium and americium in Bikini Atoll Lagoon, Health Physics 28 5 (1975) 539
- (5) WAHLGREN, M.A., et al., Study of the behavior of transuranics and possible chemical homologues in Lake Michigan water and biota, In "Transuranium Nuclides in the Environment", 9 (IAEA-SM-199/44), IAEA, Vienna (1975)
- (6) EDGINGTON, D.N., et al., Plutonium and americium in Lake Michigan sediments, In "Transuranium Nuclides in the Environment", 493 (IAEA-SM-199/44), IAEA, Vienna (1975)
- (7) FLETCHER, J.M., et al., Nitrate and nitro complexes of nitrosylruthenium, J. Inorg. Nucl. Chem., 1 6 (1955) 378
- (8) KIMURA, Y., et al., Uptake and elimination of some radionuclides by eggs and fry of rainbow trout(I), Contributed to J. Radiat. Res. (1976)
- (9) MURRAY, C.N., et al., Adsorption-desorption characteristics of plutonium and americium with sediment particles in the estuarine environment, In "Impacts of Nuclear Releases into the Aquatic Environment", 179 (IAEA-SM-198/25), IAEA, Vienna (1975)
- (10) HIYAMA, Y., et al., Uptake of radioactive nuclides by aquatic organisms: The application of the exponential model, In "Environmental Contamination by Radioactive Materials", 463 (IAEA-SM-117/17), IAEA, Vienna (1969)
- (11) KIMURA, Y., et al., Uptake and elimination of some radionuclides by eggs and fry of rainbow trout(II), Contributed to J. Radiat. Res. (1976)
- (12) ICHIKAWA, R. 'Accumulation of radionuclides by fish' Ch. 7, Radioactivity and Fish (EGAMI, N. Ed) In Japanese, Koseisha-Koseikaku, Tokyo (1973)

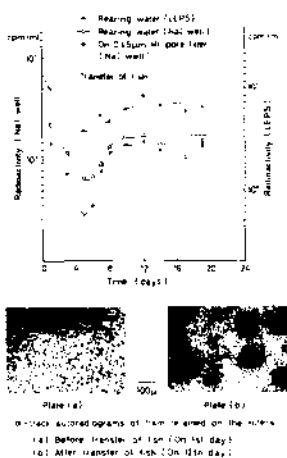
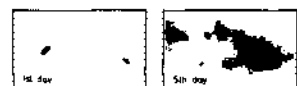
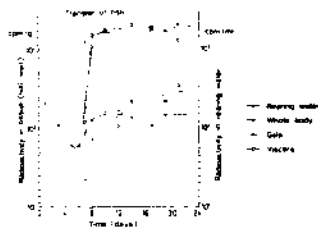

Fig 1 Radiactivity of  $^{241}\text{Am}$  in the rearing water



Track image of stomach (Frozen section of fish)

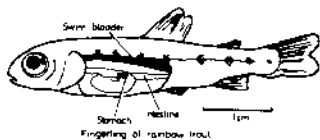

Fig 2 Uptake of  $^{241}\text{Am}$  by fingerling

Radionuclide	Rate of uptake (u)	Turnover rate (B)	Concentration factor	
			Estimated ( $^{12}\text{d}$ )	Observed (average)
$^{241}\text{Am}$	0.19	0.06	3.2	1.8
$^{60}\text{Co}$	1.82	0.32	5.7	6.5
$^{125}\text{I}$	0.27	0.35	0.8	1.9
$^{137}\text{Cs}$	0.24	0.15	1.6	1.3
$^{134}\text{Cs}$	0.97	0.41	2.4	1.8
$^{90}\text{Sr}$ -chloro	0.60	0.89	0.7	0.8
$^{135}\text{RuNO}$ -nitro	—	—	—	1.7*
$^{134}\text{RuNO}$ -nitrate	10.73	3.99	2.7	3.5
$^{135}\text{RuNO}$ -binuclear	0.07	0.07	1.0	0.9

— : Could not be estimated due to death of the fishes

\* : On 10th day

Table 1 Rate of uptake, turnover rate and concentration factor for radionuclide in whole-body of fingerling

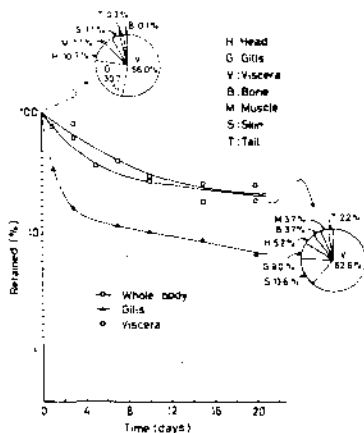

Fig 3 Retention of  $^{241}\text{Am}$  by fingerling

BIOACCUMULATION, DISTRIBUTION, AND DOSE OF  $^{241}\text{Am}$ ,  $^{244}\text{Cm}$ , AND  
 $^{238}\text{Pu}$  IN DEVELOPING FISH EMBRYOS\*

J. E. Till and M. L. Frank  
Environmental Sciences Division  
Oak Ridge National Laboratory  
Oak Ridge, Tennessee, USA, 37830

## 1. INTRODUCTION

Limited experimental data are available to evaluate potential radiological impacts and environmental behavior of transuranium elements released to aquatic ecosystems. Releases of relatively large quantities of these radionuclides to both fresh-water and marine ecosystems are not uncommon (1). The purpose of this study was to develop a methodology for assessing the dose from  $^{241}\text{Am}$ ,  $^{244}\text{Cm}$ , and  $^{238}\text{Pu}$  to the developing fish embryo, an aquatic life stage often considered to be highly sensitive to the effects of ionizing radiation (2).

## 2. MATERIALS AND METHODS

The embryo of the carp, *Cyprinus carpio*, was employed as a test organism (3). Immediately after fertilization the eggs were put into a glove box and incubated in water containing either  $^{241}\text{Am(III)}$ -,  $^{244}\text{Cm(III)}$ -, or  $^{238}\text{Pu(IV)}$ -citrate at an activity concentration of  $10^{-3}$   $\mu\text{Ci/ml}$ . This concentration was selected because it was assumed that it would not impair the normal development of the embryo (4). The citrate complex was selected since this chemical form remains in solution at neutral pH and likely results in maximum uptake by the egg.

Hatching of carp eggs occurs 72 hours after fertilization at 24°C. Eggs are approximately 2 mm in diameter and are surrounded by a chorion that is 18- $\mu$  thick. Since the range of alpha particles emitted by these radionuclides in water is approximately 45- $\mu$ , it is evident that when estimating the absorbed dose to the embryo, the amount of each radionuclide penetrating the chorion must be determined.

### 2.1 Bioaccumulation of $^{241}\text{Am}$ , $^{244}\text{Cm}$ , and $^{238}\text{Pu}$ by Fish Eggs

In order to quantify bioaccumulation in the egg, groups of 20 eggs were removed from the test solution at intervals during embryonic development. The egg chorion and contents were separated and analyzed for radioactivity. Using the results of these radioactivity analyses, concentration factors ( $\mu\text{Ci/ml}$  in contents of the egg per  $\mu\text{Ci/ml}$  in the test solution) were calculated as a function of time after fertilization (Fig. 1). In Fig. 1, the concentration factors are represented by a least-squares fit of the parabolic function  $\delta(t) = k\sqrt{t}$ , where " $\delta(t)$ " is the concentration factor at time "t" after fertilization, and "k" is a constant. Values of k for  $^{241}\text{Am}$ ,  $^{244}\text{Cm}$ , and  $^{238}\text{Pu}$  were 3.0, 4.8, and 0.44, respectively. At hatching, concentration factors were approximately 40 for  $^{244}\text{Cm}$ , 25 for  $^{241}\text{Am}$ , and 3 for  $^{238}\text{Pu}$ , however, concentration factors were lowest during early cleavage, when the embryo is known to be sensitive to ionizing radiation (5). Figure 1 indicates that  $^{241}\text{Am}$  and  $^{244}\text{Cm}$  are more readily accumulated by the contents of the egg than plutonium. The similarity in uptake of  $^{241}\text{Am(III)}$  and  $^{244}\text{Cm(III)}$  was likely due to their common states of oxidation in contrast to  $^{238}\text{Pu(IV)}$ , the most stable of the plutonium complex ions.

\*Research sponsored by the Energy Research and Development Administration under contract with Union Carbide Corporation.

## 2.2 Distribution of $^{241}\text{Am}$ , $^{244}\text{Cm}$ , and $^{238}\text{Pu}$ in the Egg

Distributions of  $^{241}\text{Am}$ ,  $^{244}\text{Cm}$ , and  $^{238}\text{Pu}$  inside the developing egg were determined by preparing autoradiographs of 16- $\mu$  thick egg sections. Each radionuclide penetrated the chorion, although the distribution of  $^{241}\text{Am}$  and  $^{244}\text{Cm}$  was noticeably different from that of  $^{238}\text{Pu}$ . During early development, before organogenesis,  $^{241}\text{Am}$  and  $^{244}\text{Cm}$  were uniformly distributed in the egg; however, as organs began to form, these radionuclides concentrated at specific sites, such as the optic cup and the spinal cord. A heavy accumulation of plutonium was found on the chorion; however, plutonium that penetrated the chorion was uniformly distributed during the entire embryonic period.

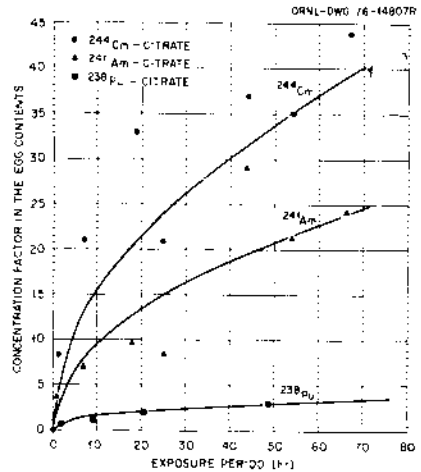

Fig. 1. Uptake of  $^{241}\text{Am}$ -,  $^{244}\text{Cm}$ -, and  $^{238}\text{Pu}$ -Citrate by Carp Eggs

## 2.3 Calculation of the Dose

The dose rate to the embryo in rad/hour was estimated using the following expression:

$$\dot{D}_a = 2.13 \epsilon_a C \delta(t) \text{ rad/hour} \quad \text{Eq. (1)}$$

where  $2.13 =$  a normalizing constant  $\frac{\text{g-rad}}{(\mu\text{Ci-hour})(\text{MeV/dis})}$ ,  
 $\epsilon_a =$  effective absorbed energy (MeV/dis),  
 $C =$  concentration ( $\mu\text{Ci/ml}$ ) of alpha radioactivity in the test solution,  
 $\delta(t) =$  concentration factor (dimensionless) for the egg contents at time  $t$  (Fig. 1), and  
 $t =$  time after the eggs were placed into the test solution.

The use of Eq. (1) assumes that radioactivity is uniformly distributed in the egg. Therefore, dose rates from  $^{241}\text{Am}$  and  $^{244}\text{Cm}$  are only approximate and may be higher at some locations in the egg. Total doses in rads to carp eggs can be estimated for  $^{241}\text{Am}$ ,  $^{244}\text{Cm}$ , and  $^{238}\text{Pu}$  for a unit concentration of activity by substituting the appropriate expression for the concentration factor, and integrating Eq. (1) over the 72-hour period of embryogenesis. These dose conversion factors would, however, be applicable only to carp embryos. If identical uptake and distribution of  $^{241}\text{Am}$ ,  $^{244}\text{Cm}$ , and  $^{238}\text{Pu}$  are assumed for eggs of other species of fish with similar embryological characteristics, then dose conversion factors could be calculated for those species by integrating the dose rate expression over the period of embryogenesis. It is also assumed that no significant differences exist in uptake and distribution between freshwater and marine species of eggs (1). Dose conversion factors for eggs of carp, fathead minnows (*Pimephales promelas*), and plaice (*Pleuronectes platessa*) developing in  $10^{-6}$   $\mu\text{Ci/ml}$  of  $^{241}\text{Am}$ ,  $^{244}\text{Cm}$ , and  $^{238}\text{Pu}$  are listed in Table 1.

Type of Eggs	Length of Embryogenesis (hr) (Reference)	Dose Conversion Factor (rads/10 <sup>-6</sup> μCi/ml)		
		<sup>241</sup> Am	<sup>244</sup> Cm	<sup>238</sup> Pu
Carp ( <i>Cyprinus carpio</i> )	72 (3)	1.4 x 10 <sup>-2</sup>	2.4 x 10 <sup>-2</sup>	2.1 x 10 <sup>-3</sup>
Fathead Minnow ( <i>Pimephales promelas</i> )	168 (6)	5.0 x 10 <sup>-2</sup>	8.6 x 10 <sup>-2</sup>	7.5 x 10 <sup>-3</sup>
Plaice ( <i>Pleuronectes platessa</i> )	432 (7)	2.1 x 10 <sup>-1</sup>	3.5 x 10 <sup>-1</sup>	3.1 x 10 <sup>-2</sup>

Table 1. Dose Conversion Factors for Fish Eggs Exposed to 10<sup>-6</sup> μCi/ml of <sup>241</sup>Am(III)-, <sup>244</sup>Cm(III)-, and <sup>238</sup>Pu(IV)-Citrate

### 3.0 APPLICATION OF THE DOSE CONVERSION FACTORS

To illustrate the use of the data in Table 1, the dose conversion factors for plutonium were applied to calculate doses to fish eggs that have similar embryological development times as carp (72 hours), fathead minnows (168 hours), and plaice (432 hours), at several locations where plutonium concentrations have been measured (Table 2). This procedure assumes that plutonium is in solution, therefore this assessment is probably conservative because of the low solubility of americium, curium, and plutonium in natural waters (1). According to reviews published by the IAEA (8) and Blaylock and Trabalka (9), these doses are several orders of magnitude less than the doses at which biological effects are expected to occur. In a similar manner, doses could also be estimated for fish eggs exposed to americium and curium if measured concentrations of these actinides in natural waters are known. Hetherington et al. (1) reported that the highest ratio of americium to plutonium discharged to the ocean from Windscale was 2.56 (in 1974) and that significantly smaller quantities of curium than americium or plutonium

Location	Plutonium Activity Concentration [μCi/ml] (Reference)	Length of Embryogenesis [hr]		
		18	72	432
		Dose [rads]		
Windscale	1 x 10 <sup>-9</sup> (1)	2.1 x 10 <sup>-6</sup>	7.5 x 10 <sup>-6</sup>	3.1 x 10 <sup>-5</sup>
White Oak Lake	9 x 10 <sup>-11</sup> (10)	1.9 x 10 <sup>-7</sup>	6.7 x 10 <sup>-7</sup>	2.8 x 10 <sup>-6</sup>
Eniwetok, lagoon	4 x 10 <sup>-11</sup> (11)	8.4 x 10 <sup>-8</sup>	3.0 x 10 <sup>-7</sup>	1.2 x 10 <sup>-6</sup>
Lake Michigan	1 x 10 <sup>-12</sup> (12)	2.1 x 10 <sup>-9</sup>	7.5 x 10 <sup>-9</sup>	3.1 x 10 <sup>-8</sup>

Table 2. Estimated Doses to Fish Embryos Exposed to Plutonium in Natural Waters

were released. Therefore, doses to eggs in the Windscale area from americium and curium would also be insignificant relative to the dose at which biological effects would be expected to occur.

#### 4.0 CONCLUSIONS

Despite the assumptions made in this study regarding differences in species, salt water vs fresh water, and concentration of  $^{241}\text{Am}$  and  $^{244}\text{Cm}$  in specific organs, it is concluded that doses to eggs exposed to concentrations of americium, curium, and plutonium found in natural ecosystems probably would not be significant. Further research on the radiobiological effects of  $^{241}\text{Am}$ ,  $^{244}\text{Cm}$ , and  $^{238}\text{Pu}$  to developing fish eggs would be useful, particularly for  $^{241}\text{Am}$  and  $^{244}\text{Cm}$  because these radionuclides concentrated at specific embryonic organs and therefore may be more harmful than plutonium at low concentrations.

#### REFERENCES

- (1) HETHERINGTON, et al., "Environmental and Public Health Consequences of Controlled Disposal of Transuranic Elements to the Marine Environment," Transuranium Nuclides in the Environment (IAEA), STI/PUB 410 (1976) 139.
- (2) POLIKARPOV, G. G., IVANOV, V. N., Action of  $^{90}\text{Sr}$ - $^{90}\text{Y}$  on Developing Khamsa Spawn, *Voprosy Ikhtiologii* 1 20 (1961) 583.
- (3) BLAYLOCK, B. G., GRIFFITH, N. A., A Laboratory Technique for Spawning Carp (*Cyprinus carpio* L.), *The Progressive Fish-Culturist* 33 1 (1971) 48.
- (4) TILL, J. E., KAYE, S. V., TRABALKA, J. R., Toxicity of Uranium and Plutonium to the Developing Embryos of Fish, ORNL-5160 (1976).
- (5) FRANK, M. L. "Sensitivity of Carp (*Cyprinus Carpio*) Embryos to Acute Gamma Radiation," Proc. of the Third National Symp. on Radioecology (NELSON, D. J., ed.), CONF-710501 (1971) 1106.
- (6) TILL, J. E., A Laboratory Technique for Obtaining Fathead Minnow Eggs for Use in Toxicity Experiments, *The Progressive Fish-Culturist* (in press).
- (7) BROWN, V. M., TEMPLETON, W. L., Resistance of Fish Embryos to Chronic Irradiation, *Nature* 203 (1964) 1257.
- (8) IAEA, Effects of Ionizing Radiation on Aquatic Organisms and Ecosystems, Technical Report Series No. 172, Vienna (1976) 57.
- (9) BLAYLOCK, B. G., TRABALKA, J. R., "Effects of Ionizing Radiation in Aquatic Systems," *Advances in Radiation Biology* (LETT, J. T., ADLER, H., ZELLE, M., Eds.), Academic Press, New York (in press).
- (10) AUERBACH, S. I., NELSON, D. J. STRUXNESS, E. G., Environmental Sciences Division Annual Progress Report, ORNL-5016 (1974) 10.
- (11) WILSON, D. W., et al., Evaluation of Plutonium at Eniwetok Atoll, *Health Physics* 29 4 (1975) 599.
- (12) NOSHKIN, V. E., Plutonium Concentration Along Freshwater Food Chains of the Great Lakes, Progress Report for AEC Contract AT (11-1)-3568, C00-3568-1 (1972).

## EFFORTS DE RADIOPROTECTION DU PERSONNEL

## POUR UN PROGRAMME ELECTRO-NUCLEAIRE

P. Baillet<sup>\*</sup>, P. Jeanson<sup>\*\*</sup>, M. Bureau<sup>\*\*\*</sup>, C. Reyx<sup>\*\*\*</sup>  
Electricité de France

Depuis 1946 en France, la distribution, le transport et la production d'énergie électrique pour sa majeure partie, ont été confiés à une entreprise nationalisée : Electricité de France. Notre Etablissement exploitait à ce titre, au 1er Janvier 1977, un parc de centrales thermiques de 23 000 MWe dont 2 500 MWe de centrales nucléaires.

Depuis 1973, le programme d'équipement nucléaire a été accéléré. C'est ainsi que 35 réacteurs, d'une puissance voisine de 1 000 MWe, sont en cours de démarrage, en construction ou engagés, et qu'en 1985 la production d'énergie nucléaire pourrait représenter environ 70 % de la consommation française d'énergie électrique.

Par ailleurs, en raison de la place qu'il occupe dans l'industrie française, de l'importance et la complexité de ses installations, de sa situation particulière d'entreprise nationalisée, E.D.F. a été amené très tôt à jouer un rôle de pionnier en matière de prévention. Prévention d'abord vis-à-vis du risque électrique en général et récemment, lors des travaux sous tension ; prévention aussi vis-à-vis de tous les autres risques qu'on rencontre dans l'exploitation des réseaux, l'exploitation des centrales thermiques et hydrauliques, la construction des ouvrages de production.

Le développement important de son programme nucléaire devait amener E.D.F., depuis quelques années, à faire porter ses efforts sur la radioprotection et à y mettre en oeuvre les méthodes qui avaient fait leurs preuves dans les autres domaines de la prévention.

Les règles fondamentales sur lesquelles repose la prévention des accidents sont les suivantes :

- prise en compte des risques au moment de la conception des installations,
- intégration complète de la sécurité tant dans les "gestes" du travail que dans la définition du rôle de chacun,
- préparation du travail, qui doit aboutir à l'élaboration de modes opératoires et d'instructions de travail,
- formation du personnel adaptée aux tâches qui incombent à chaque personne.

---

\* Service Prévention et Sécurité

\*\* Service de la Production Thermique

\*\*\* Service Etudes et Projets Thermiques et Nucléaires



Dans les lignes qui suivent, nous allons nous appliquer à illustrer l'application de ces principes au domaine de la radioprotection, au travers des principales actions entreprises par E.D.F. au stade de la conception et de l'exploitation des centrales nucléaires. Nous présenterons ainsi l'état actuel de nos réflexions et de nos travaux dans les domaines suivants :

- choix des dispositions constructives liées à la radioprotection,
- étude de décontamination des circuits primaires des réacteurs PWR,
- préparation du travail et dosimétrie d'intervention,
- organisation du travail.

Enfin, la formation du personnel fera l'objet d'une communication spéciale présentée à la session du Congrès consacrée à ces problèmes.

## 1 - DISPOSITIONS CONSTRUCTIVES LIEES A LA RADIOPROTECTION

Les dispositions constructives visant à réduire l'irradiation du personnel d'exploitation et d'entretien sont de deux ordres :

- soit l'adoption de géométries telles que l'irradiation du personnel soit la plus faible possible,
- soit l'utilisation d'outillages spéciaux permettant d'intervenir à distance sur les équipements lors des opérations d'entretien.

1.1. - Sur le premier point, nous retiendrons quelques exemples où la disposition des ouvrages permet de réduire l'irradiation du personnel.

- Pour Fessenheim\* et Bugey\*\*, le pont tournant du bâtiment réacteur prend appui sur une jupe circulaire, en avant de l'enceinte de confinement, créant ainsi un espace annulaire de 3 m de large, à la périphérie du bâtiment et sur toute sa hauteur. A partir de Tricastin\*\*\*, cette jupe est supprimée au-dessus du plancher de service, le pont tournant prenant alors appui sur des consoles solidaires de l'enceinte. Cette disposition libère une place importante sur le plancher de service, place très utile pour réaliser des chantiers d'intervention sur des matériels démontés (pompes primaires) ou pour stocker des outillages spéciaux (machine à serrer les goujons de cuve). La plus grande facilité pour le travail et la réduction du nombre de manutention qui en résultent permettent de réduire les temps de séjour dans les zones d'irradiation.

- Dans le bâtiment combustible, nous avons pu trouver des améliorations par rapport aux premières installations de Tihange, Fessenheim et Bugey. Il est désormais prévu, sur chaque tranche à partir de Tricastin, une aire de préparation du conteneur pour évacuation du combustible irradié et une aire de lavage ; les doses intégrées par le personnel auprès du conteneur sont ainsi réduites.

---

\* 2 tranches 900 MWe, PWR - mises en service 1977

\*\* 4 tranches 900 MWe, PWR - mises en service 1977-1978

\*\*\* 4 tranches 900 MWe, PWR - mises en service 1979-1980, tête de file d'un programme de 24 tranches 900 MWe réparties en 8 centrales.

- Dans le bâtiment des auxiliaires nucléaires, les interventions sur les filtres et déminéraliseurs peuvent conduire à de fortes irradiations. Disposés dans des cellules indépendantes, alignées et délimitées par des murs en béton armé de forte épaisseur, ces réservoirs sont accessibles en partie haute par des bouchons biologiques. Toutes les tuyauteries de liaison et vannes d'isolement sont disposées vers le bas. A Tihange, Fessenheim et Bugey, tuyauteries et vannes sont regroupées dans un couloir central, entre les files de réservoirs. Les commandes de vannes sont remontées dans un deuxième couloir surplombant le premier. En fonctionnement normal, l'opérateur devant isoler un réservoir n'est en vue directe d'aucun matériel. Mais lors de l'entretien des vannes, il doit accéder au couloir inférieur où il est alors en contact direct avec les tuyauteries en service desservant les autres réservoirs. A Tricastin et pour le palier W 1 300, les vannes ne sont plus disposées dans le même couloir que les tuyauteries de liaison. Toutes les vannes sont regroupées dans un couloir affecté.

- Pour l'aménagement des pompes de charge, il a été adopté le même principe consistant à séparer les fonctions.

- En vue d'adopter les meilleurs aménagements d'équipement et de leur protection biologique, nous avons engagé, dans le cadre du programme des tranches de 900 MWe, différentes maquettes, notamment celle du bâtiment des auxiliaires nucléaires (échelle 1/20) représentant non seulement le gros oeuvre et les principaux équipements, mais encore les tuyauteries de tout diamètre, chemins de câbles, gaines de ventilation, etc.

1.2. - En matière d'outillages spéciaux permettant d'intervenir au maximum à distance sur des équipements radioactifs, de nombreuses études sont menées conjointement par le constructeur de la chaudière nucléaire (Framatome) et E.D.F. Nous mentionnerons à titre d'exemple:

- étude de machines à serrer et desserrer les goujons de cuve de réacteur, machine fonctionnant en eau déminéralisée et non en huile. Cette technique doit éviter, en cas de rupture du circuit permettant l'élongation simultanée des goujons (1 300 bar), tout nettoyage en zone active,
- manipulateur pour présentation des sondes à courants de Foucault dans les tubes de générateurs de vapeur. Ce manipulateur, conçu et mis au point par Framatome, chemine seul, pas à pas, en sous-face de la plaque tubulaire,
- obturation des tubes de générateurs de vapeur par bouchon explosif, opération conduite de l'extérieur de la boîte à eau, avec récupération des déchets d'explosion.

En complément à ces études et réalisations, E.D.F. a mis en oeuvre différentes maquettes à l'échelle 1, permettant non seulement d'entraîner les équipes à opérer en position, mais encore de tester différents appareillages :

- maquettes d'un fond de générateur de vapeur, côté primaire et côté secondaire,
- maquette d'une pompe primaire pour essais d'entretien sur les étanchéités d'arbre.

---

\* 4 tranches de 1 300 MWe, PWR (4 boucles) sont déjà engagées en plus des 30 tranches de 900 MWe en construction ou engagées.

## 2 - ETUDE DE DECONTAMINATION DES CIRCUITS PRIMAIRES DES REACTEURS PWR

### 2.1. - Description de contamination

Les résultats d'exploitation des réacteurs PWR permettent de tirer les conclusions suivantes :

- a) L'activité des parois du circuit primaire situées hors du réacteur provient principalement des produits de corrosion. Au cours du fonctionnement, ces produits de corrosion sont sans cesse relâchés par les parois, activés dans le coeur, puis redéposés sur les parois des boucles ;
- b) L'activité des produits de corrosion constitue la principale source d'exposition du personnel au cours des arrêts. Environ 80 % de la dose totale est intégrée pendant les périodes de recharge-ment et d'entretien ;
- c) pendant les premiers cycles de fonctionnement, le cobalt 58, produit d'activation de nickel contenu dans les alliages inoxydables, est prédominant. Par la suite, c'est le cobalt 60, produit d'activation du cobalt contenu à l'état d'impureté dans ces alliages, qui devient prédominant, car sa période radioactive est la plus longue (5,26 ans) ;
- d) L'épuration des produits de corrosion par le circuit du contrôle volumétrique et chimique est faible.

### 2.2. - Prévention de la contamination

Divers moyens de réduire la contamination du circuit primaire sont étudiés.

- a) Une connaissance plus approfondie des mécanismes de formation et d'activation des dépôts s'impose, pour être capable d'agir en cours de fonctionnement. C'est pourquoi E.D.F. participe au développement du code de calcul "Factole" (1) par le Commissariat à l'Energie Atomique (C.E.A.). Ce code est ajusté en fonction des mesures d'activité superficielle effectuées sur plusieurs réacteurs européens de conception Westinghouse. Il confirme l'augmentation continue des débits de dose et le rôle prédominant du cobalt 60 après quelques années de fonctionnement. Il attribue un rôle important aux oxydes formés dans le circuit de contrôle volumétrique et chimique.
- b) Le relâchement des produits de corrosion par les différents matériaux et leur redéposition font l'objet de plusieurs programmes d'essai dans les laboratoires d'E.D.F. et du C.E.A.

Le relâchement d'oxydes par les stellites sera étudié, en comparaison avec celui des inconels et des aciers inoxydables, à l'aide de la boucle "Beco" prochainement mise en service par E.d.f. Si, en dépit de leur faible surface dans le circuit primaire, le relâchement des stellites était important, leur remplacement par d'autres matériaux pourrait être envisagé.

- c) La réduction de la teneur en cobalt des matériaux a fait l'objet de discussions avec le constructeur :
- inconel : la limite de 0,1 % pour le cobalt peut être réduite à 0,05 % sans majoration de prix pour la matière élaborée à Imphy (moyenne actuelle : 0,03 %),
  - inoxydable : la limite de 0,2 % pour le cobalt peut être remplacée soit par une limite de 0,1 %, soit par une moyenne pondérée égale à 0,08 % sous deux conditions : accepter une majoration de prix et limiter le tonnage demandé.

Les tôles constitutives des enveloppes des structures internes sont à présent spécifiées à moins de 0,12 % de cobalt.

- d) Le refroidissement de l'eau primaire et l'addition d'acide borique s'accompagnent d'une remise en solution partielle des oxydes. Au cours des deux derniers arrêts de Chooz\* pour rechargement, une boucle du réacteur a été isolée, et l'eau contenue dans cette boucle a été recirculée et épurée sur un circuit dérivé comportant un filtre à précouche. Les résultats ont été jusqu'ici décevants, le facteur de décontamination étant peu supérieur à 1.
- e) La décontamination par des solutions chimiques (procédé AP-Citrox) constitue, à l'heure actuelle, le seul procédé efficace. Il est rarement pratiqué en raison de ses inconvénients : prix élevé, durée, difficultés de mise en œuvre, effluents volumineux et très actifs, risques de corrosion. Il peut cependant être imposé par un incident, rendant indispensable une réparation du circuit primaire. E.d.f. étudie avec la Société Turco les matériels à utiliser, les conditions d'exécution d'une décontamination chimique des boîtes à eau ou d'une portion de tuyauteries primaires, et les répercussions sur la conception des centrales PWR.
- f) Enfin, l'épuration continue des produits de corrosion, en cours de fonctionnement, constitue une voie de recherche à plus long terme. Les débits à mettre en œuvre seraient, selon les estimations actuelles, une fraction non négligeable (quelques %) du débit principal. Il en résulterait, par conséquent, une extension importante du circuit primaire et des conséquences complexes sur la conception et la sûreté des réacteurs. Une décision d'application devrait être fondée d'une part sur une connaissance plus précise des mécanismes de transport des dépôts, et d'autre part sur des résultats d'exploitation démontrant l'efficacité de systèmes de filtration.

### 3 - PREPARATION DU TRAVAIL ET DOSIMETRIE INDIVIDUELLE D'INTERVENTION

#### 3.1. - Préparation du travail

- a) La préparation du travail est un des éléments essentiels au niveau de l'exploitation, pour la réduction des doses subies par le personnel.

---

\* Centrale franco-belge, 300 MWe, PWR

C'est en effet le principal élément de la diminution du temps d'intervention : cette étape préliminaire permet, avant l'exécution du travail, de réfléchir aux problèmes qui vont se présenter aux opérateurs et de trouver les solutions appropriées en évitant ainsi toute perte de temps sur le chantier.

D'autre part, la préparation du travail diminue les risques pour les agents, car ces risques sont évalués à l'avance et les précautions prises avant l'intervention.

Enfin, la bonne organisation de chaque chantier entraîne une bonne organisation générale qui se répercute favorablement sur les doses de l'ensemble du personnel.

b) La préparation du travail comporte deux étapes :

- la première se situe pendant la construction de la centrale ; chaque opération d'entretien systématique est analysée en élaborant une "gamme-type" : cette gamme comporte, pour chaque intervention, la nature et la chronologie des opérations à effectuer, la nature de l'outillage nécessaire, les précautions à prendre, l'estimation du temps nécessaire à la réalisation et la dose correspondante. Les "gammes-type" permettant une recherche systématique de l'amélioration des conditions d'entretien : c'est ainsi que l'on est souvent amené à prévoir des moyens de manutention supplémentaires, des ensembles facilement interchangeables, des outillages spéciaux, des facilités d'accès, des dispositifs de collecte des vidanges des matériels actifs à entretenir, éventuellement des protections mobiles, etc. Les moyens d'action pour la réduction des débits de dose sur le lieu du travail sont souvent limités ; par contre, il est possible d'agir efficacement sur la réduction du temps d'intervention ; notons au passage que cette notion de préparation réagit en feed back sur la conception et la construction de l'ouvrage ;
- la seconde étape se situe au niveau de chacune des interventions pour lesquelles le personnel doit connaître parfaitement le contenu de la "gamme-type" correspondante ; l'outillage et les pièces de rechange éventuelles doivent être préparés à l'avance. Enfin, pour les grosses opérations déjà évoquées précédemment (générateur de vapeur, pompe primaire), les maquettes à l'échelle 1 permettent un gain de temps appréciable pour l'entraînement du personnel et la mise au point des techniques d'entretien.

### 3.2. - Dosimétrie individuelle d'intervention

La dosimétrie officielle réglementaire (mensuelle) par film photographique\* est insuffisante pendant la période d'arrêt annuel au cours de laquelle sont effectués de nombreux travaux dans le bâtiment réacteur. Il est nécessaire de la compléter par une dosimétrie journalière qui permet de connaître au jour le jour les doses individuelles des agents. Cette dosimétrie est indispensable pour garantir le respect des doses maximales admissibles ; elle peut être utilisée, d'autre part, au niveau de la distribution du travail pour mieux répartir les doses entre les agents d'une même spécialité. Elle permet enfin, en regroupant les doses prises pour une même intervention, de connaître la répartition des doses selon les interventions. Cette connaissance

---

\* seule méthode réglementaire en France

des doses collectives par opération est essentielle pour déceler celles sur lesquelles un effort particulier doit être entrepris pour la réduction des doses.

#### 4 - ORGANISATION DU TRAVAIL

Les règles d'organisation découlant de l'intégration complète de la sécurité en vigueur dans tous les services d'E.d.f. se retrouvent pour la radioprotection dans les centrales nucléaires.

- Première règle : pour travailler en zone contrôlée, un agent doit être "habilité". Par ce terme, on entend :
  - . qu'il doit avoir reçu une formation appropriée, adaptée aux risques et aux niveaux de responsabilité correspondant à son travail et à sa fonction,
  - . que sa compétence à effectuer son travail ait été reconnue par le Chef de centralo. Cette reconnaissance se traduit par la délivrance d'un titre d'habilitation.

Il existe plusieurs niveaux d'habilitation de radioprotection correspondant aux différents niveaux des tâches.

- Deuxième règle : les travaux effectués en zone contrôlée doivent être exécutés sous la direction effective d'un Chef de travaux responsable des mesures de radioprotection sur le chantier. Un niveau d'habilitation et donc un niveau de formation appropriée correspondent à cette fonction.
- Troisième règle : pour pouvoir entreprendre les travaux en zone contrôlée, le Chef de travaux doit avoir reçu une "attestation de consignation" des matériels, délivrée par le Chef de quart, et un "ordre de travaux" établi par le responsable de la préparation de l'intervention, qui en précise les modalités d'exécution.

Enfin, une section sécurité-radioprotection dans chaque centrale nucléaire conseille et contrôle les différents services et organise la formation du personnel. Dans le cas de travaux présentant des risques importants d'irradiation (travaux en "zone rouge"), elle participe à la préparation du travail et à la rédaction de l'"ordre de travaux".

Ces différentes règles d'organisation font l'objet d'un "Carnet de Radioprotection" remis individuellement à toute personne travaillant en zone contrôlée.

#### 5 - CONCLUSION

En conclusion, le but de notre exposé était de montrer comment essayer de résoudre un problème vaste de radioprotection.

La solution ne peut se trouver dans un seul axe d'action, mais elle demande la conjonction de plusieurs catégories de personnes :

- des techniciens avertis des problèmes de nucléaire et ouverts à la radioprotection, pour la conception et la construction,

- des praticiens de l'exploitation et de l'entretien des centrales, pour dégager et mettre en exergue les vrais problèmes de radioprotection et, par la suite, faire vivre le système,
- des spécialistes des rayonnements ionisants, pour apporter en permanence, à la construction et dans la vie de la centrale, les informations nécessaires,
- des animateurs ou des spécialistes de la prévention, pour veiller à ce que les structures nécessaires existent et que les mesures soient coordonnées.

Ceci est ce que, en France, à E.D.F., on est en train de réaliser.

Il y a toutefois encore un volet nécessaire à une bonne radioprotection : les hommes.

Ils doivent être formés techniquement au problème, mais aussi ils doivent être sensibilisés à cette tâche, et motivés.

C'est aussi une action que nous menons.

Comme terme de ceci, nous pensons que la cohérence de ces actions doit nous permettre d'assurer le programme électro-nucléaire français dans les conditions requises de sécurité.

#### REFERENCES

- (1) FREJAVILLE G., DESLU P., MARCHAL A., SAMUEL P., "Contamination radioactive des circuits primaires des réacteurs à eau pressurisée" Conférence Nucléaire Européenne Paris, 21-25 Avril 1975.

REGULATORY PRACTICE FOR THE PROTECTION OF  
RADIATION WORKERS IN U.S. NUCLEAR POWER PLANTS

W. E. Kreger  
United States Nuclear Regulatory Commission  
Washington, D. C. 20555

Occupational radiation exposure (ORE) in U.S. nuclear power plants in man-rem per year per reactor unit<sup>1</sup>, has been steadily rising since 1969. In contrast the number of individual exposures exceeding regulatory limits<sup>2</sup> has not changed significantly in the same period,<sup>1</sup> in spite of a large increase in the number of individuals in the total work force. Table 1 summarizes this information. Activated corrosion products have been identified as the main radiation source and routine and special maintenance as the main activities contributing to OREs.

The U.S. Nuclear Regulatory Commission (NRC) carries out activities in four of its offices that include consideration of the radiation protection design and operational programs for light water reactors (LWRs). A major goal of the radiation protection regulatory program is to assure that ORE will be as low as is reasonably achievable (ALARA), in order to reduce the risk that is assumed to be proportional to the dose. Assuring exposures that are ALARA means taking into account the state of technology and the economics (costs) of improvements (in design and procedures) in relation to the benefits to the health and safety of the facility personnel.

In the NRC, the Office of Standards Development activities include development of regulations, criteria, guides, standards, and codes to protect employees of licensees and the public from the effects of NRC licensed activities. In the area of radiation protection, this office has just issued revision 2 of Regulatory Guide 8.8,<sup>3</sup> a comprehensive manual of good design and operating practices in radiation protection. It is organized into objectives for radiation exposure management as follows: (1) Program for maintaining station personnel radiation exposure ALARA; (2) Facility and equipment design features; (3) Radiation protection program; (4) Radiation protection facilities, instrumentation and equipment. Detailed descriptions of many items of benefit in exposure control and reduction are provided. The categories were derived by considering the magnitude and causes of the radiation fields in the plant, the time needed for personnel to perform functions in radiation fields, the frequency with which functions need to be performed, and methods by which each of these parameters can be changed in a manner that reduces dose. The guide is useful to architect-engineer firms, nuclear system vendors, utility company management and radiation protection personnel and others.

The Office of Nuclear Reactor Regulation develops and administers regulations, policies and procedures governing the licensing of reactor plants (as well as other facilities), including reviewing and evaluating the safety aspects of reactor sites. The radiation protection program review based on information required to be submitted<sup>4</sup> by an applicant for a construction permit (CP) and later on for an operating license (OL), is performed by the NRC staff to determine whether the standards of ref. 2 are likely to be met. Before the CP is issued, the staff must be assured that individual exposures can be kept below the Part 20 limits and total occupational exposures will be ALARA. Before an OL is issued the staff makes the same kind of decision regarding the plant as built and the planned operating procedures and radiation protection equipment and facilities. Detailed descriptions of the applicant's radiation protection design and operational policy and philosophy, of the anticipated plant radiation sources, of the plant radiation



TABLE 1  
United States  
Light Water Reactors

Year	Number of Units in Operation for the Year	Number of Overexposures to External Radiation*	Yearly Average man-rem/unit	Average Plant Age (yrs)	Average Exposure per (rem) Individual	Average Number of Personnel Receiving Measurable Exposure Per Plant
1969	7	--	178	6.13	1.06	141
1970	10	--	365	5.11	0.98	305
1971	13	2	294	5.10	0.96	302
1972	18	16	364	4.80	1.20	344
1973	26	19	534	4.32	0.91	584
1974	32	43	427	4.54	0.83	515
1975	44	14	457	4.30	0.79	578

\*Relative to 10 CFR Part 20 limits.

protection design features, of the assessed ORE exposure to the plant work force and of the proposed health physics program and equipment and facilities are required for the staff's review. The input is reviewed against the acceptance criteria of the Standard Review Plan.<sup>5</sup> Acceptance criteria include specified regulatory guides and standards such as references 2 & 3, or industry developed ANS or ANSI standards. Applicants may use the specified acceptance criteria or submit alternatives which are as good or better for reducing ORE.

After licensing, the Office of Inspection and Enforcement becomes involved in the specific plants. This office develops and administers programs and policies for inspection and investigation of activities of facility licensees to determine compliance with license provisions and NRC rules, regulations and orders. The licensees radiation protection program is thereby continually inspected during the lifetime of the plant, to assure that the standards discussed above are met, and that changes in operation or facility features carried out by the licensees result in equal or better assurance that radiation exposure limits can be met and that ORE will be ALARA. Coordination and collaboration between the Offices discussed above assures that a uniform standard of radiation protection is achieved from conceptual stages of the nuclear power plant thru to decommissioning.

The Office of Nuclear Regulatory Research plans, recommends and implements the programs of research which the Commission deems necessary for the performance of its licensing and related regulatory functions, including research on effects of routine operation of reactors on occupational health and on the environment. In the radiation protection area, several research projects have been requested to support our license review effort and related regulatory functions. In one of these, the research contractor is measuring at several operating plants the inplant radiation sources that contribute to significant radiation exposures to the plant work force. This work is to determine whether the design stage radiation protection activity is using realistic source terms for both shielding design and for deciding the locations where particular emphasis must be placed on special radiation protection practice such as remote operation, etc. A second project is a study to determine the amount of occupational dose reduction that can be achieved by implementation of the most important of the design and operational methods described in ref. 3. This data should enable the staff to concentrate its review and inspection and enforcement activities on those items that are most important for achieving exposure reductions. A third NRC project will evaluate a particular calculational method for determining neutron streaming into containment areas for PWR's. The evaluation will give the staff a better methodology for design stage evaluation of neutron or activation product dose to operational and maintenance personnel in containment.

Among the non-government groups that support research in the nuclear power area, the Atomic Industrial Forum's National Environmental Studies Project (NESP) currently has two radiation protection projects of interest to the regulatory staff. The first is "Demonstration of An Occupational Radiation Exposure Data Base", whereby a computerized personnel exposure record keeping system is being developed. It would result in greater detail of data so that the specific activities, locations, durations and types of personnel associated with significant exposure would be identified so that measures for exposure reduction could be instituted. The second NESP project of interest is called "Quantification of ALARA for Occupational Radiation Exposure". It would establish costs associated with ORE to provide a better basis for the cost-benefit analysis on whether a particular ORE is ALARA.

The Electric Power Research Institute (EPRI) has just initiated a multi-faceted program on "Radiation Control at Nuclear Power Plants", by reduction of activated corrosion products as the major source for ORE in nuclear power plants. It will look at reduction of corrosion sources, of material to be activated (particularly Co 60 precursors), at purification, at decontamination and at chemical or operational control of corrosion. The regulatory staff has also explored these subjects with nuclear steam supply system vendors and utilities.

There have been industry developed innovations in radiation protection designs and procedures in areas where large exposures have occurred. These include: a remotely operated rapid refueling development that has the potential for reducing refueling exposure by a factor of four; a remotely operated steam generator tube eddy current tester for reducing exposure in the high radiation areas in a steam generator; remote systems for removal of highly radioactive filters; and many others. Proven techniques have been incorporated in ref. 3 and have been identified in the licensing review process as desirable or necessary features of the design.

OREs at nuclear power plants designed to the new guidance and operated under that guidance should be reduced, and even further reductions should be achieved when results of the above mentioned research activities become available.

#### REFERENCES

1. Murphy, T. D., et al., Occupational Radiation Exposure at Light Water Cooled Power Reactors 1969-1975, USNRC document NUREG-0109, Aug. 1976.
2. U.S. Federal Regulation, 10 CFR Part 20, "Standards for Protection Against Radiation.
3. Regulatory Guide 8.8, Information Relevant to Maintaining Occupational Radiation Exposure as Low As Is Reasonably Achievable, Revision 2, January 1977.
4. Regulatory Guide 1.70, Standard Format and Content of Safety Analysis Reports for Nuclear Power Plants - Light Water Reactor Edition, Revision, NRC document NUREG-75/094, Sept. 1975.
5. Standard Review Plan for the Review of Safety Analysis Reports for Nuclear Power Plants - LWR Edition, NRC document NUREG-75/087, Sept. 1975.

## 10 YEARS OPERATIONAL HEALTH PHYSICS AT THE BEZNAU NUCLEAR POWER PLANTS

T. Samuel  
 Nordostschweizerische Kraftwerke AG  
 Baden - Switzerland

The two PWR of 350 MWe each have accumulated together more than 10 years of operation - in fact almost 12 years at the present time - and have produced about 30 billions kWh electrical energy. The accumulated experience has been very important. The scope of this paper is to highlight some aspects of the operational health physics problems.

Health Physics is concerned with doses: doses to the personnel and doses to the environment. These two angles will be evoked and some consequences will be shown.

## DOSES TO PERSONNEL

Fig 1 gives the evolution of the yearly accumulated doses in both plants (Beznau I has begun operation in mid 1969, Beznau II two years later).

Initially, fairly high doses have been accumulated. This was due to an initial fuel loading with a high failure rate (approx. 1 %), a corrosion problem of the vessel head, and the steam generator problem.

The steam generator problem is still a cause of concern. The work associated with the necessary inspections has not been substantially reduced, but we have learned to live with it, developing new and better techniques. As an example, the dose per inspected steam generator tube has declined by more than a factor 5 in the last three years, being now about 3 mrem per inspected tube.

Needless to say that legal dose limits have never been exceeded, but careful planning of high dose-jobs is mandatory.

However, a special aspect is worth its consideration. Incorporation of radioactive nuclides is a source of dose and extremely severe measures have always been taken, including large safety factors. The accumulated experience has shown, however, that such a working philosophy, i.e. weighting more the dose commitment due to incorporation than the dose by external radiation, has several inconveniences. The protective measures (mask, clothing) slow the work, thereby increasing the working time in a radiation field, decrease the efficiency of the worker (the sight is limited, the movements are hindered) and impose a very strong load on his physical strength (heat, breath, etc.). The net result can be - and very often is - an increase of the total absorbed dose coupled with physical exhaustion with a job less well done because the worker is tired, irritable, and even aggressive.

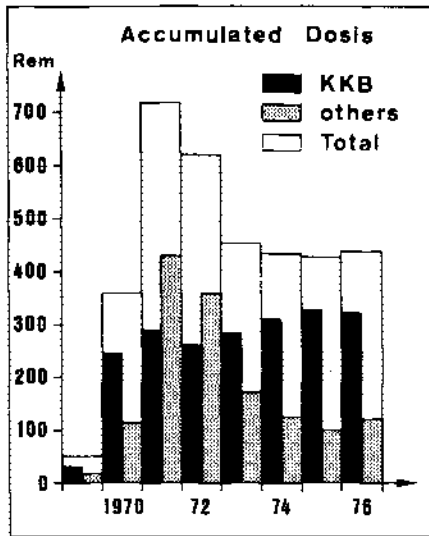

Fig. 1

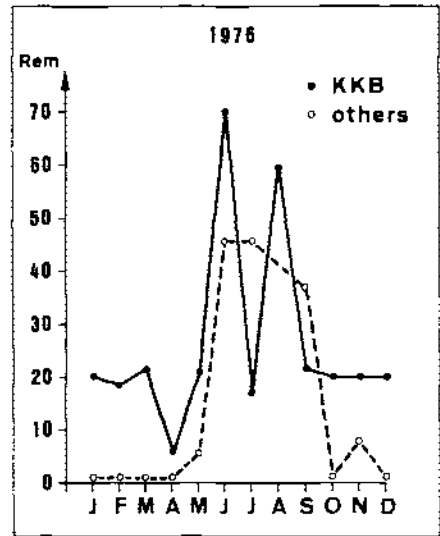

Fig. 2

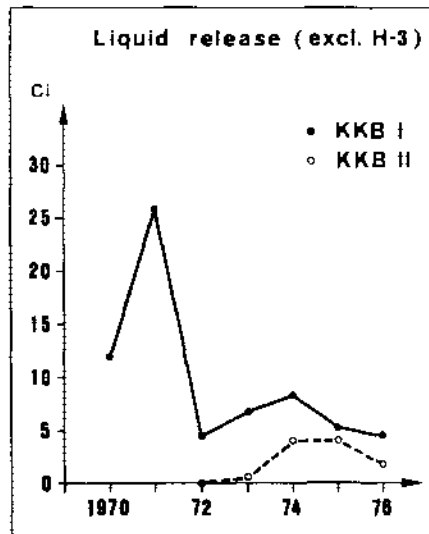

Fig. 3

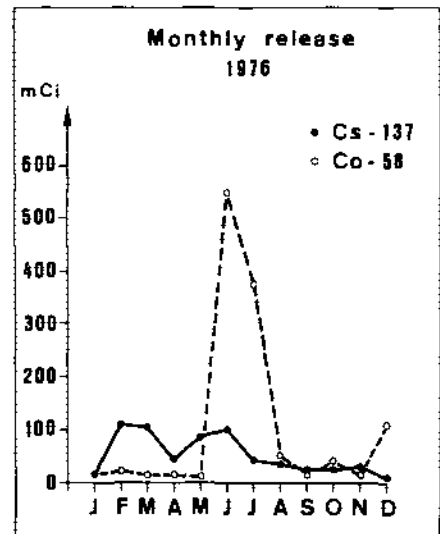

Fig. 4

One possible answer to these problems - and the answer we use - is to take only the necessary protection against incorporation, and to control frequently the workers with a whole body counter of a simple type in order to detect if incorporation had taken place. This has not been the case since this instrument was installed three years ago. Actually, we use a screening monitor giving a yes/no answer; eventually necessary fine measurements being the task of a well installed facility. We believe that dose commitments by incorporation in a nuclear power plant are a lesser problem than doses by external radiations: it has to be remembered that, by appropriate treatment, an incorporation can be reduced; a received external dose cannot. The accumulated experience shows that, in a PWR, the incorporation problem is easy to solve, and that the overconservatism of the first years can be somewhat reduced.

Fig 2 shows the doses accumulated during the year. It can be clearly seen that the major part of the doses is accumulated during the two refueling and revision periods (June and August). The small November peak is due to a shut down and repair of steam generator tubes. One of the main health physics problems is obvious: the work load is very unevenly distributed: during the shut down of Beznau I in 1976, for example, 4400 controlled entries in the containment building were registered. It is difficult, therefore, to have enough good health physics personnel for this intensive work period, and then to occupy them meaningfully during the rest of the year. An obvious conclusion, also, is that self control should be the rule, and surveillance the exception, this being reserved for very special jobs or for new or temporary personnel. A good health physics training is given therefore to all employees, and everybody is permanently motivated to enforce health physics and safety measures.

#### DOSES TO THE ENVIRONMENT

Fig 3 gives the amount of nuclides, excluding Tritium, released to the Aare river. The initial difficulties with the fuel, and also some operational difficulties, have led to releases in 1971 up to about 70 % of the allowed limits. Experience and improvements have reduced the amount of radioactivity released.

The lower releases of Beznau II are due to the fact that some services (laundry, decontamination) common to both plants are located in Beznau I.

It has been calculated by our Regulating Authorities that the release of both Beznau plants has caused a hypothetical dose to the population of 0.08 mrem/year in 1975. On the other side, waste treatment, necessary for the reduction of the released activity, is responsible for a part of the dose accumulated by the personnel. This personnel accumulates therefore additional doses of some hundred mrem per year, its general exposition is already much higher than that of the general public.

We must take into consideration this very fundamental, but unfortunately much neglected problem. The trend to always more stringent release specifications has to be payed not in money - which should be of minor importance - but in manrem for the personnel - not to speak of the increased risks due to concentration, transport and storage of radioactive waste.

Fig 4 shows some special aspects of the release problem. The type of nuclides released, and the amount, changes during the year. The release of a typical fission product, Cs-137, is rather equally distributed during the year. The activation product Co-58, on the other side, is solubilised during the shut down period, and the rate of release increases during this period. The waste treatment system must take these facts in account.

#### CONCLUSION

If it has been repeatedly and convincingly shown that the health physics problems can be solved in a nuclear power plant in complete observance of the ICRP rules, there is an aspect of the present situation which worries the author. The presently observable trend forces the health physicist to a more bureaucratic attitude: the number of rules, guides, requirements increases daily, the variety of forms, papers, statistics requested seems to be in inverse proportion to the accumulated manrem. The author has the privilege to work in a country where the bureaucratic growth has up to now been moderate, but considering the world at large, it seems that, according to Darwin, the survival of the fittest will lead to favorise the bureaucratic instead of the innovative mind, and this will without doubt lead to a deterioration of the professional level of the health physicist. It can only be hoped that reason will win.

**ANALYSES OF OCCUPATIONAL RADIATION EXPOSURE RECEIVED AT  
GUNDREMMINGEN NUCLEAR POWER STATION, AND ITS IMPLICATIONS  
ON THE DESIGN OF CURRENT AND FUTURE POWER PLANTS**

---

By N. Eickelpasch, Kernkraftwerk RWE-Bayernwerk GmbH, 8871 Gundremmingen  
K.W. Pfeiffer, Kraftwerk Union AG, Postfach 700649, 6000 Frankfurt 70  
H. Peter, Kraftwerk Union AG, Postfach 700649, 6000 Frankfurt 70

In 1976, the 250 MW Gundremmingen nuclear power station (KRB) completed its first decade of operation with an average time availability factor of 76 %.

Experience showed that about 75 % of the yearly occupational radiation exposure is applicated during outage time.

The accumulated activity build-up due to corrosion products in the primary system, the condition of the plant and the methods of radiation work management determine the occupational exposure. These three parameters are presented in fig. 1. In my opinion the plotted trends are of general character. The main parameters to be influenced are the intensity of the radiation field and the exposure time.

A necessary and effective tool of managing the occupational doses is the job related exposure accounting. This is the key for an optimal radiation work preparation and for an effective on-line radiation exposure surveillance as well.

MAINTENANCE JOB	JOB RELATED TOTAL DOSE (rem)							
	1959	1970	1971	1972	1973	1974	1975	1976
REMOVAL AND REINSTALLATION OF THE REACTOR VESSEL HEAD	4,85	5,55	7,31	5,225	2,38	2,17	2,3	2,1
REMOVAL OF THE STEAM DRYER	1,3	1,6	0,52	0,44	0,29	0,27	0,3	0,8
REINSTALLATION OF THE STEAM DRYER	3,1	3,3	3,6	1,02	0,85	0,98	1,0	1,0
REVISION OF RECIRC-PUMP-SEALS	-	6,4	5,0	3,3	5,0	5,5	5,5	5,7

Tab. 1: RADIATION DOSES OF REPEATING MAINTENANCE JOBS

Tab. 1 shows for some typical jobs that it was possible to reduce the applicated doses in most cases in spite of the increasing radiation fields (see fig. 1). This was realised by extensive efforts for accounting, documentation and evaluation of the radiation exposures.



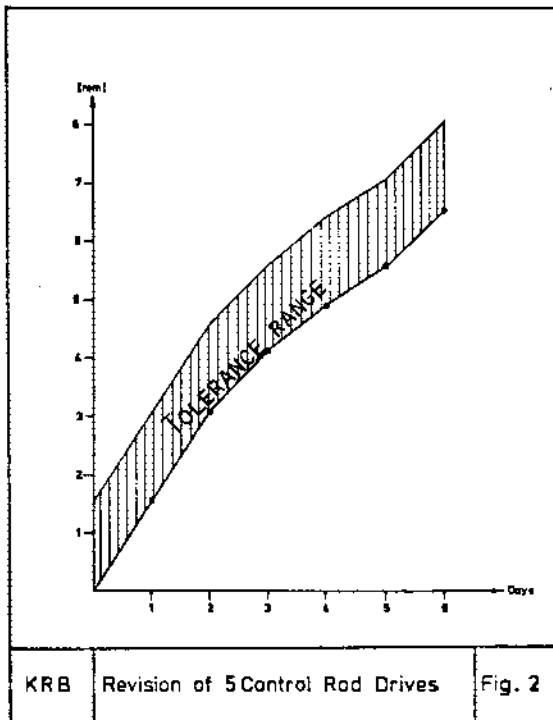
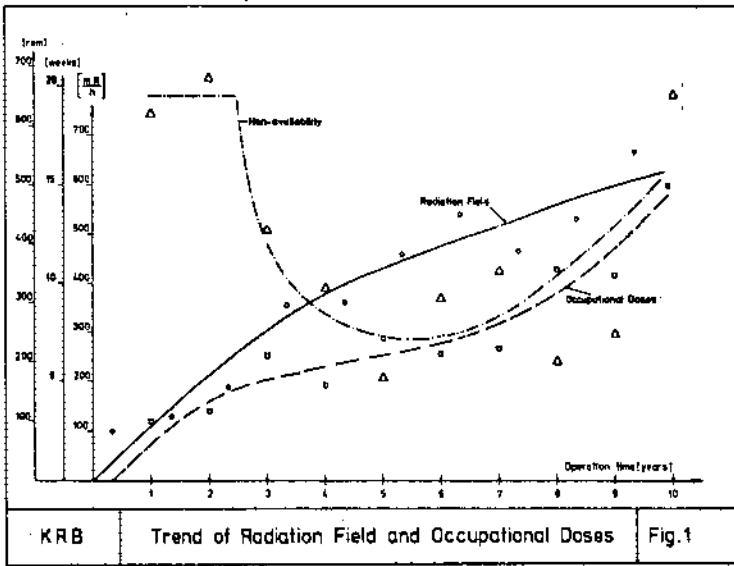

By feeding the time-dependent dose build-up (fig. 2) into a computer an effective job related dose survey procedure can be established. Alarm set-points can be programmed.

During the extended 1976 outage (replacement of the feedwater sparger) nearly 90 % of the total radiation exposure could be traced annually with an accuracy of about 10 mrem. It is shown that up to 40 % of the total exposure originates not from primary work but from associated jobs, e.g. work area preparation and testing efforts. Especially in this field a remarkable reduction in the occupational dose rate can be achieved.

An approved technique and a higher degree of automation for control will be required in the near future.

Evaluation of the KRB radiation protection history could serve as a basis for a reasonable and effective improvement in the radiation protection at future nuclear power plants. In addition to strict radiation work management, reduction in radiation exposure could be achieved by minimizing the radiation levels in those areas where maintenance work has to be carried out periodically. Though it is possible to influence, by avoiding dead legs and introducing, special operation procedures, the deposition of radioactive corrosion products in certain parts of the systems, in the areas of which maintenance and repair work has to be performed, it can not be expected, that such deposition can be completely prevented in the near future.

Therefore, an alternative approach to reduce the overall radiation exposure of the personal is being made by modifying the design, arrangement and auxiliary systems and facilities of nuclear systems and their components.

#### System and component design:

- Elimination of the external recirculation system of BWR's by the introduction of axial-flow pumps, recirculating the reactor coolant within the pressure vessel.
- The reactor coolant pumps of the PWR could be so improved that about 60 % of the working time during routine maintenance could be saved.
- Development of quickly opening manholes for steam generators to reduce the exposure time during inspection or repair.
- Design of a thermal insulation which can be removed much faster than the type of insulation used at present.
- Elimination of dead legs, piping systems and at components.

#### Component arrangement:

- Physical separation of radioactive and non-radioactive systems.
- Physical separation of nuclear components from each other as well as from the associated actuators, controls and instruments.
- Improved accessibility to reduce the exposure time.

#### Auxiliary systems:

- Provision of leak detection, gland leakoff and filtered air recirculation systems, in order to keep the airborne radioactive contamination low.
- Remote control of red-waste handling procedures.
- Provisions and space for providing temporary shielding.

HAZARDS AND PROTECTION FROM TRITIUM PRODUCED  
IN AN EXPERIMENTAL REACTOR LOOP

R.V. Osborne  
Atomic Energy of Canada Limited  
Chalk River Nuclear Laboratories  
Chalk River, Ontario, K0J 1J0, Canada

## 1. INTRODUCTION

The neutron flux reaching fuel bundles in an experimental loop of the NRX reactor at CRNL is being controlled by introducing  $^3\text{He}$  into a stainless steel coil in the annular space around the fuel. The pressure of  $^3\text{He}$  (and hence the mass of helium in the neutron flux) is varied from 100 kPa to 1 MPa by a metal bellows which, with other out-of-core control components, is in a ventilated glove box (Figure 1). The expanded volume of the  $^3\text{He}$  system is 15 litres. The (n,p) reaction on  $^3\text{He}$  produces both  $^3\text{H}$  and  $^3\text{H}$  (or T), the latter at 1.4 mCi/s (120 Ci/d or 50 MBq/s) when the reactor power and helium pressure are both maximum. Because hydrogen affects the flux control characteristics the gases are cycled over hot copper oxide (CuO) to catalytically oxidize the hydrogen so that it may be removed from the  $^3\text{He}$  by collection on a Linde molecular sieve.

Operators are therefore protected from the tritium by the integrity of the components containing the helium, by retaining the tritium oxide (HTO) on molecular sieve in the helium system, and by enclosing the accessible parts of the system in a ventilated glove box kept at a pressure several hPa below ambient. Also, as shown on Figure 1, the ambient and effluent air is monitored for tritium and the  $^3\text{He}$  in the system is monitored in the lines leading to and from the CuO/molecular sieve units. The air monitors and the differential pressure ( $\Delta P$ ) monitor have alarms.

## 2. ANALYSIS

The steps considered in estimating the distribution of tritium in the  $^3\text{He}$  system are illustrated in Figure 2 and the steps by which tritium might reach an operator are illustrated in Figure 3. The dose from tritium was calculated for each pathway through the steps in Figures 2 and 3 (46 in all) for operating times from one day to one year. Six operational or system faults were considered in the analysis:

- $^3\text{He}$  containment fails;
- the physical barriers of the glove box fail;
- the pressure differential of the glove box is lost;
- oxidized tritium is not collected on molecular sieve;
- HTO pervades the complete system before being collected;
- tritium is not oxidized.

Since the last three faults are mutually exclusive, the maximum number of simultaneous faults was four.

Assumed in calculating the doses were the following:

- contact between the operating and contaminated glove box air or component was long enough for the exposure to be determined by the ventilation rate of the glove box. (The analysis therefore included both acute and chronic releases.)

- All unbound gas, vapour, and water in the system goes into the glove box air.
- The operator took no heed of warnings of a release, a procedural error, or a system failure.

### 3. RESULTS OF THE ANALYSIS

Figure 4 summarizes the doses for an operating time (at maximum production rate of tritium) of ten days. The doses are plotted according to the number of operational or system faults that would have to occur for the particular pathways to be possible.

If the ventilation also fails, the ordinate scale in Figure 4 becomes approximately "rems per minute" except for a few pathways that involve handling contaminated objects.

Thirteen of the doses are less than 1 mrem and involve more than one fault. These pathways are not considered in detail here. The other pathways are related as shown by the letters in Figure 4.

In Groups A, B, and C the tritium is released as HTO. Within each group the estimated doses are in pairs for a given number of faults. The higher value of each pair is for oxidation of HT over CuO; the lower is for auto-oxidation of HT. Further details are as follows:

Group A: HTO is not collected on sieve and is released into the glove box air. Intake of the tritium is by inhalation (which requires 4 faults), by permeation through the unprotected skin (3 faults), and by permeation through gloves (2 faults).

Group B: HTO has pervaded the entire system before the daily collection on sieve. Intake is by contacting contaminated components by bare hands (3 faults) and by gloved hands (2 faults).

Group C: The same sorbed layer of HTO is released to the glove box air from all the inner surfaces. Intake of tritium is by inhalation (4 faults), by permeation through unprotected hands (3 faults), and by permeation through glove hands (2 faults).

In groups D, E, and F the tritium is distributed within the  $^3\text{He}$  system as HT. Details are as follows:

Group D: Elemental tritium is sorbed on the walls of the system during normal operation and intake occurs by inhalation of desorbed HTO (3 faults), by contacting contaminated surfaces with unprotected hands (2 faults), by permeation of desorbed HTO through bare hands (2 faults), by contacting contaminated surfaces with gloved hands (1 fault), and by permeation of desorbed HTO through gloves (1 fault).

Group E: No HTO has been formed in the 10 days; the intake pathways are then similar to those in Group D.

Group F: HT is inhaled. The higher dose results if no oxidation has occurred in the ten days; the lower dose results if the release occurs just prior to the normal daily oxidation and collection.

The results for one fault require only the opening of the  $^3\text{He}$  system - an operation that may be part of a maintenance task. The highest two doses have already been noted (Group D). The two doses, 'G' are for intake of HT through gloves after the daily build-up of tritium has been released before

oxidation (the higher dose) or the tritium sorbed on the walls is released. The other doses ('H') are all for the intake of HTO through gloves; by contact with HTO-contaminated parts, or by release of HTO to air with  $^3\text{He}$  or from surfaces.

#### 4. DISCUSSION

Obviously all the pathways are not mutually exclusive and an exposure may be a mixture of paths. The intent of this analysis was to evaluate the individual paths and assess whether the proposed protection was sufficient to make each exposure pathway sufficiently unlikely. Figure 4 indicates that, generally, the higher doses only occur if several faults have occurred. Quantitative estimates of probabilities for failures etc. were not attempted.

Alarm levels on the effluent and ambient air monitors may be set to trip on releases of tritium that would result in a dose of only 1 mrem and 100  $\mu\text{rem}/\text{min}$  respectively for any intake pathway. Hence for all pathways that involved dispersing tritium into the air, the stack monitor and the room monitor would alarm within seconds of releases assumed in the analysis illustrated here.

Detailed discussion of all the dose calculations, the pathways and their likelihoods will be published elsewhere. Briefly, the analysis indicates that signals from the in-line monitors, abnormalities in the operating characteristic of the loop, operating procedures and the other protective devices and monitors provided sufficient protection.

Permissible doses would only be exceeded if several protective devices fail, normal procedures are not followed and monitor alarms are ignored.

Figure 1.  $^3\text{He}$  power cycling system showing components pertinent to the tritium hazard analysis.

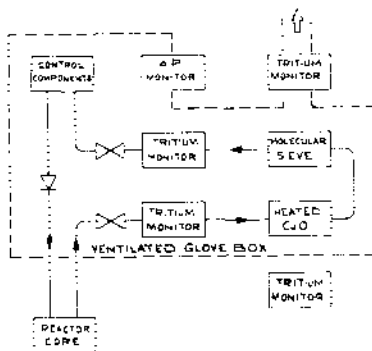

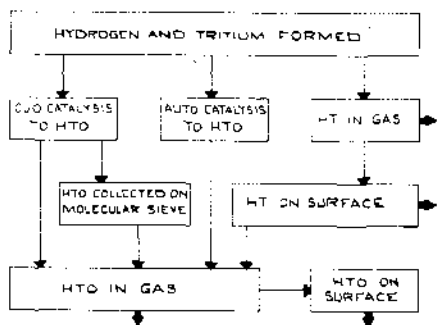

Figure 2. Distribution of tritium in the  $^3\text{He}$  system. The broad arrows indicate the sources of tritium if the system is opened. HT refers to elemental tritium; HTO to tritiated water.

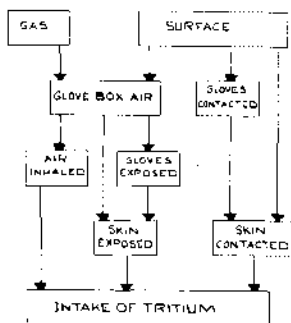

Figure 3. Exposure to tritium released from the  $^3\text{He}$  system.

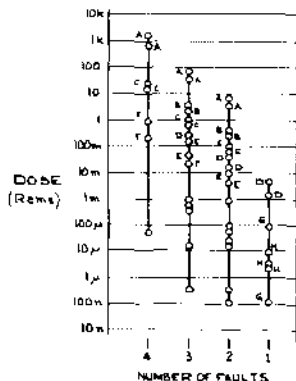

Figure 4. Doses from tritium released from the  $^3\text{He}$  system. The doses are plotted against the number of faults that would have to occur for each particular dose to occur. The lettered groups are sets of doses that occur by related pathways as discussed in the text.

CONTRIBUTION INDUSTRIELLE A LA REDUCTION DES  
IRRADIATIONS DU PERSONNEL D'INSTALLATIONS,  
NUCLEAIRES PAR DECONTAMINATION CHIMIQUE.

EXEMPLES ET RESULTATS OBTENUS

J. Lecerf (2)  
E. Soumillon (1)  
J.P. Rombaux (2)

(1) Turbo Products Belgium SA Ninova, Belgique  
(2) E.N.I., S.A., Aertselaar, Belgique

L'augmentation importante, au cours de ces dernières années, tant du nombre de centrales nucléaires que de leur capacité unitaire et de leur durée de vie, a entraîné inévitablement un accroissement des niveaux d'exposition du personnel aux radiations. La presse nucléaire spécialisée (1) a mis d'ailleurs récemment l'accent sur cette augmentation sensible de même que la U.S. Nuclear Regulatory Commission (2) qui a établi notamment une récapitulation des expositions encourues par le personnel d'exploitation de 1969 à 1975.

La sous-estimation actuelle des nécessités d'entretien ainsi que les difficultés en cours de réparation et d'entretien résultant de l'augmentation d'activité des équipements ont, par ailleurs, été considérablement mises en évidence au cours de la dernière Conférence Internationale sur l'Energie Nucléaire Mondiale, organisée par l'ANS et l'ENS en Novembre 1976 à Washington, qui en avait très logiquement conclu que des méthodes de décontamination plus efficaces devraient pouvoir être développées (3).

Les méthodes de décontamination les plus couramment utilisées actuellement sont à caractère soit mécanique ou hydraulique, soit chimique. Bien que les méthodes de décontamination mécanique aient, dans certains cas, leur utilité parmi les équipements ou ateliers de décontamination de centrales, la quasi totalité des résultats obtenus par ces méthodes (qu'il s'agisse de projection par robots haute pression ou de micro grenailage) ont été loin, à notre connaissance, d'être convaincants et n'ont généralement pas pu conduire à des facteurs de décontamination supérieurs à 2 pour des équipements contaminés à chaud.

Par contre, les méthodes de décontamination chimique, tout en offrant toutes les garanties nécessaires en matière de corrosion, ont conduit jusqu'à présent, lorsqu'il étoit fait appel à des procédures et des décontaminants fiables adéquats, à des facteurs de décontamination s'élevant selon la nature, la difficulté et les conditions d'intervention, de généralement minimum 20 à 250 avec certaines valeurs ayant même dépassé 1.000.

Ces tels résultats ont notamment été obtenus en Europe, lors de décontaminations chimiques effectuées à la Centrale SENA de Cheetz (après les incidents de 1958), à la centrale RB3 de Mol, à la centrale RBWR de Winfrith pour ne citer que les principales et non classifiées, ainsi qu'à de nombreuses centrales nucléaires américaines et notamment à Hartford (4) où des décontaminations par voie chimique ont été réalisées sans conséquence mesurable de corrosion à 4 reprises sur les générateurs de vapeur, et 8 reprises sur l'ensemble du circuit primaire du réacteur "APR" de 4000 MWth.

La décontamination de la pompe primaire n° 3, effectuée en janvier 1977 par l'Association Turco-FNI dans l'enceinte du bâtiment réacteur de Tihange (PWR de 870 MWa), constitue un autre exemple récent et particulièrement démonstratif de réduction possible des irradiations du personnel par décontamination chimique. Cette pompe primaire, de type à fuite contrôlée, présentait depuis quelques mois une légère fuite nécessitant la rectification d'un plan de joint, planifiée pour le premier arrêt de réacteur, vers le fin de l'année 1979. Les prévisions les plus optimistes, faites avant toute possibilité de mesure au niveau des parties de l'hydraulique de la pompe en contact avec l'eau du circuit primaire, faisaient craindre, comme cela fut vérifié par après, des débits de dose de 5 à 10 Rem/heure. Ce tels débits auraient compliqué à outrance et fort probablement empêché les travaux de rectification du plan de joint.

En fonction des difficultés attendues, l'option de décontaminer chimiquement les parties radioactives de l'hydraulique fut retenue.

L'installation des équipements nécessaires à cette décontamination fut grandement facilitée grâce à l'existence d'un atelier de décontamination proche du bâtiment réacteur. Les solutions chimiques nécessaires furent préparées dans les cuves de l'atelier et envoyées, via une tuyauterie fixe, dans une cuve blindée, placée à l'intérieur du bâtiment du réacteur et équipée de chauffage, d'un système d'agitation et de transducteurs à ultrasons très puissants.



La décontamination chimique consiste, dans une première étape, à faire passer les éléments chimiques de la couche d'oxydes à un état de valence supérieure à l'aide de produits décontaminants alcalins ionisés, puis à dissoudre après rinçage, dans une seconde phase (acide), la couche d'oxydes, toute recéposition étant exclue par le choix de la formulation du produit utilisé.

Les opérations qui ne prirent que quelques heures, sans qu'aucune des personnes ayant participé aux opérations n'ait été exposée à plus de 25 mR/j. de dose cumulée, permirent de faire baisser les débits de dose aux valeurs mesurées par SEMO et FRAMATOME) que l'on peut lire au tableau 1. Les travaux de rectification du plan de joint furent ensuite effectués, durant 3 semaines, sans aucune difficulté ni de personnel ni d'équipement.

Il est indéniable que la décontamination chimique contribuera particulièrement à l'avenir, non seulement à freiner mais même à réduire progressivement les expositions du personnel à travailler et à séjourner auprès d'équipements contaminés et que les résultats obtenus par ce type d'interventions sont nettement plus positifs que les simples limitations ou restrictions des expositions aux rayonnements.

#### REMERCIEMENTS

Les auteurs tiennent à remercier ici, tout particulièrement, les représentants de SEMO, EDF, JEUMONT-SCHNEIDER et FRAMATOME ayant contribué, directement ou indirectement, au succès des opérations de décontamination ainsi qu'aux mesures, pour leur aide précieuse et leur collaboration constructive et efficace.

#### REFERENCES

- (1) ALAN MARTIN - Occupational radiation exposure in LWRs increasing - Nuclear Engineering International - January 1977, pp. 32-34
- (2) NUREG - 0109 - Occupational radiation exposure at light water cooled power reactors 1969-1975; US Nuclear Regulatory Commission - August 1976
- (3) Nuclear Marketing Report (of Nuclear News) - Vol. 2, n° 22 - December 1975
- (4) W.D. BAINARD - Decontamination of A-Reactors stainless steel steam generators - Proceeding 25th Conference, National Association of Corrosion Engineers, March 1969, pp. 425-427.

+ +

ASSOCIATION TURCO - ENI

AVANT/APRES DECONTAMINATION	mRem/h	mRem/h
2000	150	
3500	65	
4000	85	
4500	180	
5500	100	
4000	55	
3500	25	
3000	25	
6000	200	



TABLEAU 1

## ICRU ACTIVITIES

H. O. Wyckoff  
7910 Woodmont Avenue  
Washington, D.C. 20014

I appreciate very much the invitation from your Congress President to present a short summary of recent ICRU activities. I was asked to emphasize the current situation regarding the International System of Units so that this could be discussed in some detail following this paper. In addition, I would like to present briefly a short summary of three reports that the ICRU has just published.

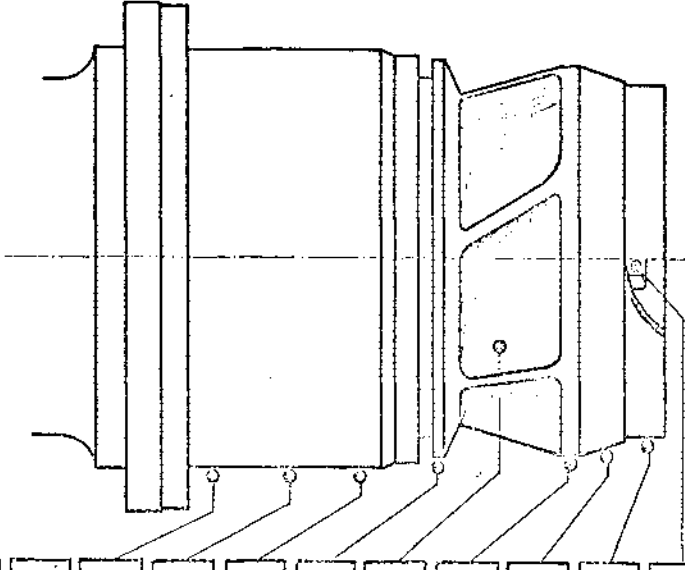
The International System of Units

While the name "International System of Units" (SI) was selected in 1960, the components of this measurement system had been in the process of development for many years and there are indications that some modifications are still to come.

In order to provide a proper background for understanding the import of this system, it is well to review the hierarchy that was set up by the "Treaty of the Metre" in 1875. Under this Treaty, there are two organizations - the General Conference of Weights and Measures and the International Committee for Weights and Measures - and one laboratory, the International Bureau of Weights and Measures<sup>(1)</sup>.

The General Conference of Weights and Measures is composed of delegates from the states who are signatories of the Metre convention. As of January 1, 1975, there were forty-three such states. This Conference meets at least every six years.

The International Committee for Weights and Measures is composed of eminent scientists from eighteen different countries. They are selected by the General Conference and serve in a personal capacity - that is, they are not representatives of their governments. However, many of these scientists are senior members of their national standardizing laboratory. This committee supervises the operation of the International Bureau of Weights and Measures, prepares material for consideration by the General Conference and is responsible for implementing the Conference's decisions. The International Committee meets at least every two years and its president, vice president, and secretary serve as an executive committee to examine current business, to keep the International Committee informed, and to prepare for meetings of its parent body. To assist the International Committee, there are several consultative committees of which one is the Consultative Committee for Units. Table 1 shows the inter-relationships between these organizations.

During its 1948 meeting, the General Conference instructed the International Committee: "to study the establishment of a complete set of rules for units of measurement"; "to find out for this purpose, by official inquiry, the opinion prevailing in scientific, technical, educational circles in all countries" and "to make recommendations on the establishment of a practical system of units of measurement suitable for adoption by all signatories to the Metre Convention". Before considering the system that was developed following this instruction, it may be useful to review briefly a few concepts and the rationale for the development of the system.

Even prior to the "Treaty of the Metre" the concept of "physical quantities" was fairly well developed and the interrelationships between quantities had begun to be expressed by mathematical equations. A physical quantity is an entity used for the precise description of a phenomenon. Each physical quantity can be expressed as a product of a pure number and a unit.

In developing a system of units one could, of course, decide upon a special name for the unit of each quantity. This was not done because there are known mathematical relationships between a number of the quantities. Thus, the tendency has been to limit the number of units and use the mathematical relationships between the quantities to derive the units for other quantities. For example, an area is given by the product of two lengths. Thus, if the unit for length is specified, an area has the unit of the unit of length squared. This may be expressed mathematically as:

$$\begin{aligned} [\text{area}] &= [\text{length}] [\text{length}] \\ &= [k_1(\text{unit of length})] [k_2(\text{unit of length})] \\ &= k_1 k_2 (\text{unit of length})^2 \end{aligned}$$

where  $k_1$  and  $k_2$  are pure numbers. Similarly, if a unit for length and one for time are specified, the unit for velocity is the quotient of the specified units. This may be expressed mathematically as:

$$\begin{aligned} [\text{velocity}] &= [\text{length}]/[\text{time}] \\ &= [c_1 (\text{unit of length})]/[c_2 (\text{unit of time})] \\ &= \frac{c_1}{c_2} \frac{\text{unit of length}}{\text{unit of time}} \end{aligned}$$

where  $c_1$  and  $c_2$  are pure numbers. It was found that the specification of units for length, mass and time were adequate for quantities employed in mechanics. Many of you remember the centimeter-gram-second (CGS) system which resulted. Difficulties arose when the CGS system was applied to electrical and magnetic quantities by means of the equations relating them to the mechanical quantities. The unit of electrical charge (abcoulomb) derived from electromagnetics is then equal to the velocity of light times the unit of charge (statcoulomb) derived from electrostatics.

$$1 \text{ abcoulomb} = c \text{ statcoulomb}$$

where  $c$  = velocity of light. In addition, the expression of electrical quantities by units of the mechanical quantities, resulted in a fractional exponent for some of the mechanical quantities. For example:

$$\begin{aligned} [\text{charge in electrostatic system}] &= \\ &= [\text{dielectric constant}]^{1/2} [\text{mass}]^{1/2} [\text{length}]^{3/2} [\text{time}]^{-1} \end{aligned}$$

Specification of another unit for the electrical area ("electric current" in amperes) solved these difficulties.

For the description of thermal phenomena, another unit based on the thermodynamic temperature is required. The concept of "temperature" and its unit kelvin resulted.

While the mass is acceptable for mechanical phenomena, in chemistry the number of molecules is much more useful. For this reason, the concept of "amount of substance" and its unit, mole, resulted.

To include a measure of light as viewed by the eye, another quantity "luminous intensity" and its unit, candela, has been provided. It is essentially the energy of light per unit area weighted by the response of the "average" eye according to an agreed upon relative luminous efficiency. The weighting is different for photopic and scotopic vision.

The resulting seven base units of the International System of Units, along with their symbols and quantities, are listed in Table 2. These, together with two supplementary units - radian (symbol rad) for plane angle and steradian (symbol sr) for solid angle - provide the reference set of units from which the other units in the International System of Units may be derived. A few of these derived units have special names. For example, the SI unit for periodic frequency is reciprocal second. The special name for reciprocal second for use with this quantity is hertz.

There are a few units that do not fit into the International System of Units but that have been approved for use with the SI. These include some for which no time limitation of usage is specified. Some of these, such as minute and hour of time, are permitted because of long continued common usage and others are included because their magnitude depends upon experimental determinations - such as electron volt. There were a few units - as of 1972 - that were accepted for use with the International System of Units for a limited time. These included the curie, roentgen and rad whose SI units are reciprocal second, coulomb per kilogram and joule per kilogram, respectively. The "limited time" was not specified in the document on this subject prepared in 1972 by the International Bureau of Weights and Measures with the assistance of the Consultative Committee on Units, and containing the resolutions and recommendations of the General Conference of Weights and Measures. However, several countries immediately started to consider changing their laws to eliminate the units that were recommended for limited time usage.

Recognizing that senior personnel in the major national standardizing laboratories had agreed to the recommendations included in the International Bureau of Weights and Measures document, and remembering that the calibration of our ionizing radiation measuring devices ultimately depend upon calibration by such national laboratories, it appeared obvious to the ICRU that curie, roentgen and rad would soon become ruled out.

As it appeared that many persons in the field of ionizing radiation were not fully cognizant of this trend, the ICRU attempted to alert these scientists to the possible action by soliciting their comments (2,3). From these comments it appeared that a number of persons wished to retain the historical names for the units. In view of the actions that already had been taken, this didn't seem to be a viable position. An even larger group opted for a change to the International System of Units, if special names could be chosen for them and if the change-over to the new names was not too precipitous.

On the basis of these replies, the ICRU developed arguments for special names for reciprocal second and joule per kilogram. These were forwarded to the General Conference of Weights and Measures through the Consultative Committee on Units and the International Committee on Weights and Measures. On the basis of these recommendations, the General Conference of Weights and Measures approved the special name gray for joule per kilogram and the special name becquerel for reciprocal second (4).

At the time that the initial submission was made to the Consultative Committee on Units, no decision had been made by the ICRU and the ICRP on the unit for dose equivalent. Since that time there have been discussions within each of the Commissions and within the ICRP/ICRU liaison committee. Sievert was selected as the special name of the SI unit (joule per kilogram) for dose equivalent. This name (symbol Sv) is to be used in ICRP Reports. The official approval of this name must await its consideration by the Consultative Committee on Units, the International Committee of Weights and Measures and finally by the General Conference of Weights and Measures.

Before leaving the topic of the International System of Units, it should be said that there are a number of points still under discussion. For example, some thought is being given to either eliminating or placing in a special category the quantities and their units that contain weighting factors - particularly biological ones. This discussion will then include consideration of luminous intensity with its unit, candela, and dose equivalent with its unit, sievert. It is still too early to predict the outcome of these discussions.

One should also say that if the International System of Units finally comes into universal use, and it may be found that the "units to be used with the International System" are no longer needed, then the statement of the unit will be redundant if one indicates the pertinent quantity. One could then say, for example:

"The absorbed dose is  $4.51 \times 10^{-3}$ "

and one would understand

"The absorbed dose is  $4.51 \text{ mJ/kg}$  (or  $4.51 \text{ mGy}$ )". If this happens - and many feel that it will - the special names for units will no longer be needed. There may be special pressures for such a development because many persons working in this area have argued against the proliferation of specially named units.

#### Current ICRU Reports

In the past few months, the ICRU has published its Reports 24, 25, and 26 (6,7,8) on "Determination of Absorbed Dose in a Patient Irradiated by Beams of X or Gamma Rays in Radiation Therapy Procedures", "Conceptual Basis for the Determination of Dose Equivalent" and "Neutron Dosimetry for Biology and Medicine".

Report 24 is the second in a series of primers on the subject of therapeutic dosimetry - the first, ICRU Report 23 (9), dealt with the absorbed dose in a phantom from a single beam of x and gamma rays. Report 24 outlines methods for taking into account (a) multiple ports of entry of the radiation, (b) inhomogeneities in the body, and (c) the body's contours. It also deals with the accuracy desired in therapy. In addition, there is a glossary and an extended series of references for more detailed information.

Report 25 summarizes the relationships between the various quantities of interest in radiation protection and expands on the concepts associated with the "index quantities" recommended in ICRU Report 19 (5). The use of such concepts permits the specification of an absorbed dose index field or a dose equivalent index field for external sources (in the same way as is

now done for exposure free in air) without the lengthy presentation of the geometry that would otherwise be required. It does this by specifying a phantom size, requiring it to be spherical so that orientation is unimportant and specifying that the "index" be the maximum value of the quantity in that phantom. The 30 cm diameter selected for the phantom size approximates that of the trunk of an adult.

ICRU Report 26 deals primarily with neutron dosimetry but because gamma rays are always present in most applications, the document includes some treatment of their measurement also. The various methods are discussed and compared. The document includes some didactic treatment of the quantities given very succinctly in ICRU Report 19 (5). In addition, the document includes material on neutron sources, beam monitoring, and deals briefly with special problems that arise in neutron dosimetry for therapy and radiobiology. It also includes a series of appendices on fundamental data of interest for this topic and a short discussion of ionization chamber construction.

Convention of the Metre

1875

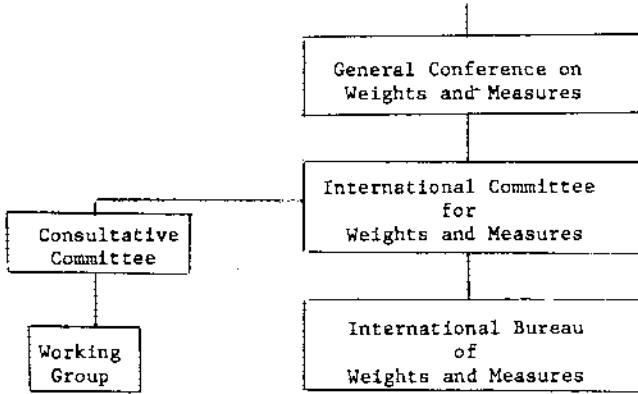

Table 1 Organs of the Metre Convention



Table 2

## SI Base Units

<u>Quantity</u>	<u>Unit</u>	
<u>name</u>	<u>name</u>	<u>symbol</u>
length	metre	m
mass	kilogram	kg
time	second	s
electric current	ampere	A
thermodynamic temperature	kelvin	K
amount of substance	mole	mol
luminous intensity	candela	cd

### References

- (1) "Le Bureau International des Poids et Mesures 1875-1975"  
Pavillon de Breteuil, F 92310 Sevres, France (1975)  
also in English translation by U.S. National Bureau of  
Standards as NBS Special Publication 420 (Page, C. H.,  
Vigoureux, P. Eds) U.S. Government Printing Office,  
Washington, D.C. 20402
- (2) Liden, K., SI Units in Radiology and Radiation Measurement.  
Health Physics 25, 2-0 (1973)
- (3) Liden, K., Special Radiation Units and/or SI-Units  
Health Physics 26, 583 (1974)
- (4) Liden, K., The New Special Names of SI Units in the Field of  
Ionizing Radiation, Health Physics 30, 417 (1976)
- (5) "Radiation Quantities and Units", ICRU Report 19,  
International Commission on Radiation Units and Measurements,  
Washington, (1971)
- (6) "Determination of Absorbed Dose in a Patient Irradiated by Beams  
of X or Gamma Rays in Radiation Therapy Procedures", ICRU  
Report 24, International Commission on Radiation Units and  
Measurements, Washington (1976)
- (7) "Conceptual Basis for the Determination of Dose Equivalent"  
ICRU Report 25, International Commission on Radiation Units  
and Measurements, Washington (1976)
- (8) "Neutron Dosimetry for Biology and Medicine", ICRU Report 26,  
International Commission on Radiation Units and Measurements,  
Washington (1976)
- (9) "Measurement of Absorbed Dose in a Phantom Irradiated by A Single  
Beam of X or Gamma Rays", ICRU Report 23, International  
Commission on Radiation Units and Measurements, Washington (1973)

## Notes

## Notes

## Notes

## Notes

## Notes



**ASSOCIATION INTERNATIONALE DE RADIOPROTECTION  
INTERNATIONAL RADIATION PROTECTION ASSOCIATION**

**IV<sup>e</sup> CONGRÈS INTERNATIONAL  
IVth INTERNATIONAL CONGRESS**

**RECUEIL  
DES COMMUNICATIONS**

VOLUME 3 - Jeudi 28 avril

---

**PROCEEDINGS**

VOLUME 3 - Thursday April 28th

---

**PARIS 24-30 AVRIL 1977**



## COLLECTIVE DOSES FROM PRACTICES INVOLVING RADIATION EXPOSURES

D. Beninson  
Secretary of UNSCEAR

## 1. INTRODUCTION

Radiation doses are determined or estimated in two main types of radiation protection assessments: a) individual-related assessments, where individual dose data are taken to indicate the level of risk incurred by exposed individuals; and b) source-related assessments, aiming at the evaluation of the total consequences of given radiation sources, and which take account therefore of all exposures caused by the sources. This paper reviews a number of sources and practices which involve radiation exposures, with the aim of providing source-related assessments. This review is based on the assessments carried out by UNSCEAR (1).

## 2. GENERAL CONSIDERATIONS

Practices involving radiation sources give rise to a distribution of doses in the exposed population. No single quantity can represent adequately the distribution for all risk assessment purposes. A useful quantity for source-related assessments is the collective dose. The collective dose in a population,  $S$ , is defined as the weighted product of dose and number of individuals of the exposed population. The collective dose is therefore given by the expression

$$S = \int_0^{\infty} D N_D(D) dD$$

where  $N_D(D)$  is the population spectrum in dose,  $N_D(D)dD$  being the number of individuals of the exposed population receiving a dose in a specified organ or tissue due to the source, in the range  $D$  to  $D + dD$ . The collective dose is an extensive quantity that can apply to one person, to a population group or to the whole world population. It is expressed in man rad (or man Gy), or in man rem, as appropriate.

In some cases, the exposure of the population is delivered over considerable time after the originating event. In order to have a measure of the total exposure of the population, caused by the source, the collective dose commitment is used. The collective dose commitment,  $S_k^c$ , due to a given event, decision or "finite practice"  $k$  is defined as the infinite time-integral of the collective dose rate,  $\dot{S}_k(t)$ , caused by that event, decision or "finite practice"

$$S_k^c = \int_0^{\infty} \dot{S}_k(t) dt$$

where the collective dose rate is the weighted product of dose rate due to the source and number of individuals in the exposed population

$$\dot{S}_k(t) = \int_0^{\infty} \dot{D}_k N_{D_k}^c(D_k) dD_k$$

The calculation of collective dose commitment from source  $k$  requires that all individuals receiving a dose from the source are included in the population under consideration. As the integral remains unchanged if the population is made arbitrarily larger than the actual exposed group by adding unexposed persons, it is convenient to specify the population as the world population. This specification is not necessary when the exposed group is small and well defined in a way that every exposed person could be accounted for.

The collective dose commitment from a source is particularly useful for two purposes. On one hand it can be used in relative detriment assessments, on the assumption that the risk of deleterious effects is proportional to dose, while their severity is independent of the frequency of exposure. On the other hand, it can be used to assess future exposures from continued practices.

A continued practice causing radiation exposure can be considered as a sequence of events, each delivering exposures over times which may exceed the duration of the event. The collective dose commitment is usually proportional to the size of the originating event. For example, if the event under consideration is the release of a radionuclide to the environment, the collective dose commitment is proportional to the activity released, provided all other influencing factors remain constant. It is therefore possible to define a collective dose commitment per unit practice, as for example in the case of nuclear power it is possible to define a collective dose commitment per Mwe(y) of electric energy generated.

It can be shown that in the case of a continued practice the resulting average (per caput) dose rate will increase and eventually reach a steady state. In the simplified case of a constant population, the steady state per caput dose rate,  $\bar{D}_{\infty}$ , is given by

$$\bar{D}_{\infty} = \frac{R}{N} S_1^c$$

where  $R$  is the practice rate, namely the number of units of practice per unit time,  $N$  is the population size and  $S_1^c$  is the collective dose commitment per unit practice. In many cases it is possible to make rough projections of the practice rate per caput,  $R/N$ , such as, for example, the nuclear installed capacity per person, and it is then possible to predict the maximum per caput dose rate that will be experienced in the future.

For exposures delivered over a very long time, as in the case of exposures due to the release of carbon-14, it would not be realistic to assume a continued practice for such long times as required by the per caput dose rate to approach steady state. It can be shown that, in these cases, the maximum per caput dose rate to be experienced in the future is approximated by

$$\bar{D}_{\max} \approx \frac{R}{N} S_1^i$$

where  $S_1^i$ , called the incomplete collective dose commitment, is the time-integral of the collective dose rate caused by one unit of practice,  $\dot{S}_1(t)$ , over a period  $\tau$  equal to the estimated duration of the continued practice

$$S_1^i = \int_0^{\tau} \dot{S}_1(t) dt$$

The incomplete dose commitment per unit practice clearly does not relate to the detriment per unit practice but only to a part of it. It is however useful to predict the maximum per caput dose rate due to a continuing but finite practice.

### 3. SOURCES OF HUMAN RADIATION EXPOSURES

Source-related assessments are particularly useful in cases where human decisions affect the resulting exposures, since collective dose commitments could be attached to such decisions, and could be taken to represent a measure of the consequential detriment. The natural radiation sources are in a special category because only part of the exposure to these sources can be influenced by human decisions. While there are "technologically enhanced exposures to natural sources", such as, for example, in high altitude flights or in the use of construction materials with high radium content, there is a background of

exposure from natural sources from which these examples may be seen as more or less artificial deviations. This "unmodified" background varies with altitude and geographical location and is a useful reference level of radiation exposure.

### 3.1. "Unmodified" exposure to natural sources

The various natural radiation sources include *external* sources such as cosmic rays and radioactive substances in the ground and in usual building materials, and *internal* sources in the form of naturally occurring radioactive substances in the human body, particularly potassium-40. The contribution of natural sources to the per capita dose in areas of normal radiation background is summarized in Table 1.

	Genade	Lung	Bone lining cells	Red bone marrow
<i>External irradiation</i>				
Cosmic rays	28	38	25	28
Terrestrial radiation	32	32	32	32
<i>Internal irradiation</i>				
Potassium-40	15	17	15	27
Radium-226 (with daughters)	0.3	40	0.3	0.3
Other nuclides	2	6.5	9.1	4
Total	78	104*	95	92

TABLE 1

\*) A substantial fraction (87 per cent) of this dose is caused by alpha radiation which is expected to have a higher biological effectiveness than the beta and gamma radiations, which cause more than 50 per cent of the dose in the other tissues. An annual dose of the order of 300 mrad is received by the epithelial cells of the tracheo-bronchial tree.

Much higher external doses are received by population groups living at high altitudes or in regions of high natural activity. Some population groups are also exposed to elevated internal doses, for example people living in houses of low ventilation rate in the colder climates, using radon-rich waters, or consuming from particular food chains.

The annual collective dose to the world population from natural sources is about  $3 \cdot 10^6$  man rad for most of the body tissues, and about 50 per cent higher for the lung. These values are useful in relative detriment assessments, because collective dose commitments due to given practices can be expressed as equivalent durations of exposure to natural sources, e.g. durations which would cause the same collective dose commitment as the practices.

### 3.2. Technologically enhanced exposures to natural sources

A total of about  $10^9$  passenger hours are spent travelling by air each year. Under average solar conditions the annual collective dose contributed by

air travel is about  $3 \times 10^5$  man rad. High radiation levels at high altitudes during solar flares are infrequent events which will not add significantly to the collective dose to the world population, but make it necessary to equip supersonic aircraft with monitoring devices to allow for prompt remedial actions. The collective dose commitment from one year of air travel is equivalent to about 9 hours of unmodified exposure of the world population to natural sources.

Very large quantities of phosphate rock are mined, some of the material being converted to fertilizers and some disposed as waste. As phosphate deposits contain usually high concentrations of the uranium-238 decay series, both practices may lead to exposure of the public. In addition, one by-product is chemical gypsum which may be used as a building material. The collective dose commitment from phosphate fertilizers is small, of the order of  $10^4$  man rad per tonne of rock. If all the phosphogypsum from the marketable ore were used in the building industry, however, the resulting collective dose commitment would be a few man rad per tonne of ore, equivalent to about 0.3 seconds of natural background per tonne of ore.

Another example of technologically enhanced exposures to natural sources is the use of special building materials, either of natural origin or made from products of industrial processes. The dose rates in air from gamma radiation in buildings of such materials may be 2 to 20 times higher than the average normal dose rate from terrestrial radiation. The radon levels will also be considerably enhanced for a given ventilation rate.

### 3.3. Medical uses of radiation

The exposures of the patients during medical procedures are of particular interest since they contribute the highest man-made per capita doses in population, are given with high instantaneous dose-rates and cause the highest individual organ doses, except in accidents. The individual doses to the patients must be decided by the medical doctors on the basis of the need for a diagnosis or treatment. The patient's dose in various organs and tissues, therefore, may vary from entirely insignificant doses up to high doses which cause local tissue damage near treatment areas.

The collective doses from medical irradiations are therefore composed of a large variety of individual doses. However, the largest contributions to the collective doses come from types of exposures which involve large numbers of individuals, as is the case in some diagnostic x-ray examinations. In these cases the per capita doses to the organ of interest have been found to be roughly similar in magnitude, in many technologically developed countries being in the order of 100 mrad per year. This means that the annual collective dose from medical practices is of the order of  $10^9$  man rad per million of population.

It is estimated that the occupational exposure of workers in the medical field gives an annual collective dose in the order of  $10^7$  man rad per million of population. This occupational contribution is insignificant compared to that from the irradiation of patients. The annual global collective dose from medical procedures may be estimated to be of the order of  $10^{10}$  man rad, equivalent to about 120 days of natural radiation background.

### 3.4. Nuclear explosions

Not including the contribution from carbon-14, the per capita global dose commitment from all nuclear explosions carried out before 1976 range from about 100 mrad in the gonads to about 200 mrad in bone-lining cells. In the northern temperate zone the values are about 50 per cent higher while in the southern temperate zone they are about 50 per cent lower than these estimates. External

exposures, mostly from caesium-137 and short-lived nuclides, contribute about 70 mrad to the global dose commitment for all tissues. Internal exposures are dominated by contributions from caesium-137 and from strontium-90 in the skeleton. The contribution from carbon-14 is about 120 mrad for the gonads and lung and 350 mrad for the bone lining cells and the red bone marrow.

The collective dose commitment from nuclear test explosions varies from  $4 \cdot 10^6$  to  $8 \cdot 10^6$  man rad in different tissues, if the carbon-14 contribution is not included. Since the carbon-14 doses will be delivered over many thousand years, it is interesting to assess the incomplete collective dose commitment from this nuclide. If the duration of atmospheric nuclear testing is taken to be about 30 years, the incomplete collective dose commitment is estimated to be  $4 \cdot 10^7$  to  $10^8$  man rad, adding a small contribution to the collective dose commitment from the other nuclides. The total collective dose commitment in different tissues from nuclear explosions is equivalent to about 18 to 27 months of exposure of those tissues to the corresponding natural radiation levels.

### 3.5. Nuclear power production

The use of nuclear reactors for the production of electric power is now an established technology. The total installed nuclear generating capacity in 1976 was about 80 GW(e) from 137 power reactors operating in nineteen countries. The projected capacity by the year 2000 is about 2000 GW(e).

The nuclear fuel cycle involves a series of steps, comprising the processes of mining and milling of uranium, conversion to fuel material (in most cases including enrichment in the isotope uranium-235), fabrication of fuel elements, utilization of the fuel in nuclear reactors, storage of the spent fuel, reprocessing of this fuel in cases where the fuel cycle is closed, transportation of materials between the various installations, and the ultimate disposal of radioactive waste. Almost all the radioactive material associated with the nuclear industry is present in the reactors and in spent fuel or in well-contained fractions separated from the fuel during the reprocessing operations. However, at each step of the fuel cycle, releases of small quantities of radioactive material into the environment occur.

The total collective dose to the world population may be assessed by estimating the contribution from four components, namely the occupationally exposed group, the local population in the vicinity of installations of the fuel cycle, the regional population and the world population. The last three components are the result of environmental releases of radioactive materials. Most of the radionuclides released are only of local or regional concern, because their half-lives are short compared to the time required for dispersion to greater distances. Some radionuclides, on the other hand, having longer half-lives or being more rapidly dispersed, can become globally distributed.

A special problem arises in the case of a few radionuclides which have very long half-lives. The most important examples are uranium-238 ( $4.5 \cdot 10^9$  y) and iodine-129 ( $1.6 \cdot 10^7$  y). The exposure periods of many million years make the collective dose commitments high. For example, uranium from the mining and milling industries and the related production of radon will cause collective dose commitments of the order of 100 man rad per MW(e)y in the lung, the bone-lining cells and the red bone marrow. Uranium from the fuel fabrication industry may contribute about ten times as much. Iodine-129, if released from reprocessing plants, would contribute about 2000 man rad in the thyroid per MW(e)y. However, the exposure periods are so long that the meaning of these commitments is unclear. In fact, to accumulate a collective dose of only 1 man rad per MW(e)y from these nuclides a period between  $10^4$  and  $10^6$  years

would be necessary. The exposure from these nuclides is not discussed in the following considerations.

Carbon-14 presents similar problems. The collective dose commitment from carbon-14 released from light water reactors and related processing plants is estimated to be about 5 man rad per MW(e)y in soft tissues and 14 man rad per MW(e)y in bone lining cells and red bone marrow. One half of this collective dose will be delivered within 5700 years. Because it takes some time for carbon-14 to become dispersed in the oceans, as much as one fifth of the collective dose will be delivered within 500 years. If it is assumed that the nuclear industry can operate at the rate occurring in year 2000 for some 500 years, the incomplete collective dose commitments are therefore about 1 man rad per MW(e)y in soft tissues and 3 man rad per MW(e)y in bone marrow and bone lining cells.

The collective dose commitments in different tissues are summarized in Table 2. The values for gonads are in the lower range, while those for the thyroid and lung are the highest.

Step in cycle	$S_1^T$ [man rad/MW(e)y]	Type of exposure
Reprocessing	1.1 - 3.3	global
Research and development	1.4	occupational
Reprocessing	1.25	occupational
Reactor operation	1.0	occupational
Mining, milling and fuel fabrication	0.2 - 0.3	occupational
Reactor operation	0.25 - 0.35	local and regional
Reprocessing	0.2 - 0.8	local and regional
<u>Whole industry</u>	5.4 - 8.4	

In the summation for the whole industry the occupational contributions dominate. Because of the age distributions of those occupationally exposed and of the public, only about 30 per cent of the lower value of the range for the whole industry would be of genetic significance.

The estimated collective dose commitment for the whole industry per MW(e)y generated is equivalent to about 0.56 seconds of exposure to the natural radiation background. One year of operation at the 1976 installed capacity gives a collective dose commitment equivalent to about 1/2 day of natural irradiation, while one year of operation at the projected capacity for the year 2000 would be equivalent to about 12 days. This forecasts into the future are quite uncertain, because they depend on both technology and regulations which may vary substantially.

### 3.6. Consumer products emitting radiation

A variety of consumer products contain radionuclides which have been deliberately incorporated to satisfy a specific purpose. Main examples are radio-luminous products, some electronic devices, antistatic devices, gas and aerosol detectors, ceramics and glassware containing uranium and thorium. In addition, some electronic products, such as television sets, may emit x rays.

Until the 1960's radium-226 was the most common nuclide in radioluminescent paint and therefore also in watches and alarm clocks. At present tritium is used for the same purpose. The wearer of an average radium activated wrist watch receives a gonad dose of a few mrad per year. A person wearing a tritium activated wrist watch may receive from tritium leakage a whole body dose of 0.1 to 0.2 mrad per year. The present use of radioluminescent paint in the watch industry may cause a collective dose to the world population of the order of  $10^7$  to  $10^8$  man rad in a year, equivalent to 2.5 to 25 hours of exposure to the natural radiation background. Too little is known about the number of products that are actually on the market in various countries and the amount of activity involved. It is difficult to assess, therefore, the average dose due to these products. However, there is a gradual improvement of control, and it seems likely that the annual collective dose to the gonads from the use of radiation-emitting consumer products is less than  $4 \cdot 10^6$  man rad at present, corresponding to some 100 hours of natural irradiation.

#### REFERENCES

- (1) Report of the United Nations Scientific Committee on the Effects of Atomic Radiation. To be published as a report to the General Assembly and as a UN sales publication in 1977.

CURRENT STATUS OF THE HOT PARTICLE ISSUE  
(A REVIEW OF RELEVANT EXPERIMENTAL AND THEORETICAL APPROACHES)

W.J. Bair  
Battelle  
Pacific Northwest Laboratories  
Battelle Boulevard  
Richland, WA 99352 USA

## 1. INTRODUCTION

The possibility that radioactive particles or highly focalized accumulations of radioactivity deposited in the respiratory tract are more hazardous than uniform irradiation of the lungs has been speculated upon for more than 30 years (1). Although research on inhaled radionuclides has not provided evidence that particulate or other focal sources of radiation are inordinately more hazardous than uniform radiation exposures, strong concern has been expressed that the risk of lung cancer from particles of alpha-emitting radionuclides in the lungs may have been underestimated. This concern has been reflected in reports seeking a reduction in the occupational and environmental exposure standards for plutonium (2-6). In response to this concern, numerous reports on various aspects of the hot particle issue have been prepared by scientists in the U.S. and abroad representing government agencies, professional societies, research laboratories, and standard setting bodies (7-16). I will briefly summarize the arguments that I believe are most relevant to the question of whether plutonium particles in the lung are a greater health risk than more uniformly distributed radioactivity.

The stimulus for the most recent dialogue on the topic of particulate alpha-radiation sources was a petition by the Natural Resources Defense Council to the U.S. Environmental Protection Agency and the Atomic Energy Commission for a reduction in the permissible lung burdens for plutonium-containing particles in the lung (2). The 1974 petition first asked for a 115,000-fold reduction in the current radiation standards. This was later changed to a 1000 to 2000-fold reduction (17). This request was based on the argument that focal tissue damage produced in the lungs by particles containing a minimum of 0.07 pCi (later increased to 0.6 pCi) of alpha-emitting radionuclides will lead to cancer and that the risk of cancer is 1 in 2000. This figure was derived from the petition authors' premise that a threshold response exists and that the probability of cancer induction is 1 in 2000 when a critical mass of tissue is irradiated at a dose of at least 1000 rem per year by a particle deposited in respiratory tissue. In support of this the authors cited published studies on tumors in irradiated rat skin, a report on a noncancerous lesion in the palm of a machinist's hand in which a particle of plutonium metal had been deposited, and reports of noncancerous lesions in lungs of rats and hamsters given plutonium microspheres intravenously.

Edward Martell, a radiochemist on the staff of the National Center for Atmospheric Research, added his voice to the argument about plutonium



hazards. However, while the NRDC emphasis was on relatively high alpha activity particles, Martell considered low alpha activity particles to be effective carcinogens. His argument was based on speculation that the very low levels of  $^{210}\text{Pb}$  and  $^{210}\text{Po}$  observed in particles of cigarette smoke is "the likely cause of cancer" in cigarette smokers (6).

More recently John Gofman, Professor Emeritus of Medical Physics at the University of California at Berkeley, entered the plutonium argument with claims that fallout plutonium is already causing lung cancer in people throughout the world. Gofman's estimates of lung cancer induction by plutonium are based not so much on the "hot particle" theories as on a "hot spot" concept. He claims, without providing evidence, that inhalation of plutonium particles results in areas of high radiation dose to the bronchial epithelium, the tissue where most human lung cancers originate. Gofman maintains that this is especially significant in smokers because of assumed long-term retention of plutonium particles in regions of impaired clearance (4).

The hot particle reports have been examined and rejected by the majority of scientists in the field and by scientific bodies such as the Nuclear Regulatory Commission, Energy Research and Development Administration, National Council on Radiation Protection and Measurement, National Radiological Protection Board and the Medical Research Council of Britain. The conclusions of these reports were summarized recently by Richmond (16). Finally, the National Academy of Sciences released a report in October 1976 that represents the consensus of a committee of radiation biologists with extensive research experience in areas relevant to the "hot particle" issue (14). I will draw largely from the NAS report in summarizing the issue's current status.

## 2. FATE OF INHALED PARTICLES

A few facts about the behavior of inhaled insoluble alpha-emitting particles are helpful in examining the hot particle issue. The site of deposition in the respiratory tract depends upon the size and velocity of the inhaled particles. The largest particles, which are deposited in the nasal pharynx, will be cleared to the external environment and swallowed within a few hours. Somewhat smaller particles, deposited in the trachea and bronchi, are removed with a half time of about three days to the gastrointestinal tract. The smallest particles, deposited in the pulmonary regions of the lungs, are cleared with a half time of 300-1000 days by either dissolution, transport to the regional lymph nodes, or transport by mucus and ciliary action to the gastrointestinal tract. Plutonium particles retained in the lungs are almost always found in the peripheral regions near bronchioles, in lymphatic vessels beneath the pleural surface, and sometimes in scar tissue.

While cigarette smoking causes temporary slowing of mucus flow and ciliary action along major bronchi, there is no evidence of long term retention of particles on the bronchial epithelium or of impaired clearance of particles from the pulmonary region of the lung. This contradicts Dr. Gofman's belief that cigarette smokers are at greater risk from inhaled plutonium particles than non-smokers because of long retention of highly radioactive particles on the bronchial epithelium.

### 3. EFFECTS OF ALPHA RADIATION ON CELLS

Knowledge of the interaction of alpha radiation with living cells is still incomplete. Most of our information is from studies of cell mortality rather than studies of cell transformation. Results of these studies suggest that traversal of the cell nucleus by an alpha particle will usually cause sufficient irreparable damage to interfere with reproduction of that cell line. (Chromosome aberrations can often be found in cells irradiated with alpha particles, but these cells are usually considered to be reproductively dead.) On the other hand, a single traversal of the cytoplasm will not generally disrupt the cell's ability to survive and reproduce. However, when only a portion of the energy from an alpha particle is absorbed by a cell nucleus, the cell may retain its reproductive capability but pass on to its progeny any genetic alterations that occur. Some of these events may have a role in cancer induction.

Cancer induction may also be associated with extensive cell killing. Cells killed by alpha irradiation are generally replaced by proliferation of adjacent cells as part of the repair process. In areas of low radioactivity, in the presence of a single or a few plutonium particles, the repair processes are usually in tune and the tissue appears normal, a common observation in animals that have inhaled plutonium particles. In areas of very high radioactivity, such as an accumulation of plutonium particles, repair processes are less apt to be in balance. If the radiation dose is large, sufficient numbers of dead cells may accumulate to form necrotic lesions. Overcompensation of proliferating adjacent cells can result in production of scar tissue and a change in the shape of the tissue structure, as seen in animals that have inhaled plutonium particles. The radioactive particles which started the process may be trapped in this region of rapid cell growth or pushed aside and possibly cleared from the lungs. The associated blood vessels may also be disrupted, either as a direct result of irradiation or as a result of the overcompensating repair processes. Abnormal cells can occur amid these processes--again a direct result of the irradiation or a result of abnormal growth conditions such as an impaired blood supply. The progeny of these abnormal cells may have tumor cell characteristics. If such cells are not selected out during subsequent cell divisions, tumor development can follow. Studies of inhaled radionuclides in animals indicate that only a very small fraction of necrotic lesions lead to cancer, but at this time we cannot predict whether a given lesion will or will not develop into a tumor.

Current knowledge of the interaction of alpha radiation with living cells is consistent with the observation of lung cancer in experimental animals which have inhaled plutonium. The possibility of cancer being induced by single particles cannot be excluded; however, the probability that cancer will be induced by a given particle will depend upon whether the amount of plutonium in the particle is sufficient to kill some adjacent cells, or sufficient to impart just enough energy to cause changes leading to cell transformation and eventually cancer. These probabilities were examined theoretically in reports by Mayneord and Clarke (18) and by the NCRP (11) with the conclusion that the risk of cancer may be greater for particles of a certain plutonium content than for others--namely the particle which would result in single alpha traversals through the maximum number of cancer sensitive cells or regions within cells. Attempts to determine this critical plutonium particle will be fruitless without better information about the movement of particles throughout the lung and about the dynamics of lung cells. However, as the

NCRP report (11) points out, the risk would be no greater, and in most cases less, than if the plutonium were distributed uniformly throughout the lungs.

#### 4. DATA FROM EXPERIMENTAL ANIMALS

Data from animal experiments can be used in several ways to examine the validity of the concept that particulate alpha radiation sources in lungs are exceptionally potent inducers of cancer. One way is to compare the frequency of lung cancer in animals after inhalation of plutonium and other alpha emitters with estimates of the lung cancer risk in humans exposed to other sources of radiation. A second approach is to test the cancer risk per particle of 1 in 2000 predicted by Tamplin and Cochran using estimates of numbers of Pu particles in the lungs of experimental animals that developed cancer. Finally, results are available from an extensive experiment in which known numbers of particles of different specific activities were deposited in the lungs of hamsters.

Sufficient experiments have been completed with inhaled alpha emitters in experimental animals to permit derivation of risk coefficients. Comparison of these risk coefficients with those obtained for other sources of radiation and other tissues and with risk coefficients from human exposures to radiation should provide an indication of whether the cancer risk associated with inhaled alpha-emitting particles is appreciably greater than that posed by other radiation sources.

Table 1 gives risk coefficients from several sources for human cancer induced by high LET radiation, e.g., alpha radiation such as from plutonium. Since there are no reported cases of plutonium-induced cancer in human beings, these risk coefficients were derived from other types of radiation, largely low LET radiation. Thorne and Vennart's (19) estimates (Table 1) were derived from human exposures to various kinds of radiations as reported in the BEIR and UNSCEAR reports and are applied to high LET radiation by assuming a quality factor of 20. Mays' estimates (20) were derived from  $^{226}\text{Ra}$  and thorotrest data on humans, the BEIR report, and beagle dog experiments and were applied specifically to plutonium. The risk coefficients for rats were calculated by applying a linear model to pooled data from all experiments of inhaled transuranics reported in the literature (21). The beagle value is an estimate derived from a single high dose experiment in which nearly all dogs developed lung cancer over a period ranging from about 3-11 years after inhalation of  $^{239}\text{PuO}_2$ .

	MAYN			EXPERIMENTAL ANIMALS	
	Thorne & Vennart (19)	MRC (22)	Mays (20)	Beagles	Rats
Lung	400	750	200	1,600 (21)	800, 1600* (21)
Liver	200	200	100		
Skeleton	100	46	200	1000	
Thyroid	1000				
Breast	1000				
Leukemia	600				

\*For relatively soluble and insoluble transuranics, respectively.

TABLE 1 Risk Coefficients for Induction of Cancer by High LET Radiation (cases/10<sup>6</sup>/rad)

The risk coefficients for inhaled plutonium (and other transuranics) in experimental animals range from 600 to 1600/10<sup>5</sup>/rad. Some of the rats were exposed to relatively soluble transuranics. The radiation dose was more widely distributed in the lungs of these animals than in the lungs of the animals given insoluble particles, which may account for the factor of two difference in risk between these two groups. However, it can be assumed with some confidence that the transuranic elements accumulated to some extent in the lungs in all animals, whether they inhaled insoluble or relatively soluble transuranics, so that most of the radiation dose was distributed in "hot spots".

Since none of these risk coefficients can be considered precise, only gross comparisons are possible. Also, human sensitivity to radiation-induced lung cancer may vary from that of experimental animals. For example it has been shown that mice and dogs are far more sensitive to radiation-induced osteosarcoma than humans (20). The risk estimates for several kinds of cancer in human beings and the values for transuranics in animals overlap. However, the estimated risk coefficients for lung cancer in humans tend to be somewhat less than half those obtained for experimental animals. The difference between the lung cancer risk in humans, which was obtained mostly from relatively uniform radiation exposure, and the risks observed for experimental animals, which were exposed mostly to particulate alpha radiation sources, is probably no greater than 10. This seems rather insignificant in view of uncertainties in the quality factor for alpha radiation, possible differences in susceptibility to tumor development between experimental animals and humans and the quality of the risk coefficient data being compared.

The National Academy of Sciences report used the results of a study of 40 beagle dogs given single inhalation exposures to <sup>239</sup>PuO<sub>2</sub> aerosols to assess the possibility of a hot particle effect of the kind envisioned by Tamplin and Cochran (14). Nearly all of the dogs in the study developed lung cancer which may have been due to either or both of two types of radiation exposures: 1) generalized alpha irradiation of the lungs from <sup>239</sup>PuO<sub>2</sub> particles and 2) alpha irradiation from discrete plutonium particles (a hot particle effect).

Whether any hot particle effect contributed to lung cancer mortality in the dogs, as Tamplin and Cochran predict, can be judged by comparing the number of lung cancer deaths observed with the number expected on the basis of Cochran and Tamplin's risk factor (1/2000 per hot particle). The results of such an analysis indicate that if there is a hot particle effect, the cancer risk per particle is lower by at least several orders of magnitude than Cochran and Tamplin estimated. The analysis also shows that all of the lung cancer deaths in the plutonium dogs are readily attributable to the absorbed lung dose from the alpha radiation. In other words, the beagle experiment indicates that any hot particle effect is overshadowed by the effect of the generalized alpha irradiation the dogs experienced (14).

As shown in Table 2, the average dog that died of lung cancer is estimated to have had deposited in the pulmonary lung regions approximately 1.3 million 0.07 µCi particles and 200 thousand 0.6 µCi particles. These numbers are calculated on the basis of the measured particle size distributions of the aerosols the dogs inhaled (14).

On the basis of Cochran and Tamplin's assumed risk constant of 1/2000 per hot particle, the average dog would have developed during a 11-1/2 year life span 650 lethal lung cancers, if they were produced by the 1.3 million 0.07 µCi particles. In the dogs that had lung cancer at the time of death it is not

Estimated Number of Hot Particles Deposited in the Pulmonary Regions of the Battelle Group of 15 Beagles That Died Between 0 and 3600 Days of Lung Cancer. [Calculated on the assumption of (1) a log normal frequency distribution with respect to particle size before inhalation of the aerosol, and (2) a constant deposition frequency in the pulmonary regions; that is, any particle is equally likely to reach the pulmonary regions regardless of its size.]

	Type of Aerosol		Weighted Means
	A CMD <sup>b</sup> = 0.5 μm σ <sub>g</sub> <sup>c</sup> = 2.3	B CMD = 0.25 μm σ <sub>g</sub> = 2.1	
Number of Dogs Exposed That Died of Lung Cancer	5	10	
Mean Initial Lung Burden (ILB; μCi)	1.0 <sup>a</sup>	1.10 <sup>a</sup>	1.07
Estimated Number of Type 1 Hot Particles (≥0.07 pCi)	4.1 × 10 <sup>5</sup>	1.8 × 10 <sup>6</sup>	1.3 × 10 <sup>6</sup>
Estimated Number of Type 2 Hot Particles (≥0.6 pCi)	1.4 × 10 <sup>5</sup>	2.1 × 10 <sup>5</sup>	1.9 × 10 <sup>5</sup>

<sup>a</sup>For one of the dogs exposed to aerosol "B" the initial lung burden has not been determined. Therefore the initial lung burdens and particle number estimates are based upon 10 instead of 11 dogs; the omitted dog died with a lung cancer as cause of death 3537 days after exposure to the aerosol.

<sup>b</sup>CMD = Count Median Diameter

<sup>c</sup>σ<sub>g</sub> = Geometric Standard Deviation

NOTE: When allowance is made for differential pulmonary deposition (see Figure A1-2), the numbers of Type 1 and Type 2 particles deposited in the deep lungs are likely to have been higher than those shown in this table.

TABLE 2 Estimates of "Hot Particles" in Beagle Dogs (14)

known how many primary death-causing lung cancers were present. Multicentric tumors occurred in most dogs, attributable either to metastasis from one primary cancer (metastases of lung tumors to regional lymph nodes were frequent) or to the occurrence of multiple primary cancers. Since primary tumors are expected to arise as rare independent events and therefore in accordance with the Poisson distribution, the mean number of lung cancers can be indirectly inferred from the observed cancer death rate. Using Life Table methods it was calculated that the average dog had 1.9, rather than 650 or 100, primary death-causing lung cancers (14).

Thus the beagle data indicate that if there was a hot particle effect and if that effect was responsible for all of the lung cancer deaths in the animals, the associated lung cancer risk still would be only one chance per 670,000 per 0.07 pCi particle, or one chance per 100,000 per 0.6 pCi particle compared with Cochran and Tamplin's one chance per 2000 particles (14).

Whether the observed lung cancer mortality in the plutonium dogs can be accounted for solely on the basis of the dose received from the generalized alpha radiation can be assessed by referring to the lung cancer risk coefficients in Table 1. The risk calculated for inhaled Pu in beagle dogs agrees well with the risk observed in rats exposed to relatively soluble alpha-emitting transuranics in which the number of hot particles would be nearly absent or minimal. Further, it does not differ greatly from estimates of the cancer risks derived from human exposures to, largely, low LET radiations. The conclusion is that lung cancer mortality in the dogs appears to be adequately accounted for by the conventional method of averaging the absorbed alpha dose over the entire lung. Therefore it was concluded in the National Academy of Sciences report that if there is a hot particle effect the lung cancer risk per particle has not only been greatly overestimated but, more importantly, such a risk is small by comparison with the lung cancer risk attributable to the generalized alpha radiation (14).

At Los Alamos Scientific Laboratory an experiment was designed specifically to test the hot particle concept. Syrian golden hamsters were given intravenous injections of known quantities of microspheres containing plutonium

or the beta emitter,  $^{147}\text{Pm}$ , of varying specific activity. The microspheres dispersed widely in the pulmonary capillaries, where they lodged. Preliminary results from this experiment (Table 3) were published in the NAS report (14). The tumor incidence observed in hamsters in which the lungs received relatively diffuse alpha irradiation exposures was 10-30% while the tumor incidence in hamsters given  $^{238}\text{Pu}$  microspheres which irradiated less than 3% of the lung mass was only 1%. This was interpreted as conclusive evidence that highly localized alpha irradiation of the lungs is less effective in causing lung tumors than more diffuse alpha irradiation.

Specific Activity (pCi/sphere)	Number of Spheres	Lung Burden (pCi)	Approximate Dose <sup>a</sup>	Tumor Animals	Incidence (% ± S.D.)	BAI <sup>b</sup> Animals	Incidence (% ± S.D.)
<b>"DIFFUSE" EXPOSURES (greater than 25% of lung mass exposed)</b>							
Intratracheal sp. $^{238}\text{Pu}$ N.A. <sup>c</sup>	N.A.	0.22 <sup>d</sup>	1.7 krad total	14/47	30 ± 6	12/47	24 ± 7
Intravenous spheres $^{238}\text{Pu}$ 2	70,000	0.14	1.3 krad/yr	17/163	10 ± 3	85/163 <sup>e</sup>	32 ± 5
Intravenous spheres $^{238}\text{Pu}$ 450	50,000	22.0	28 krad/yr	12/54	22 ± 6	16/54	30 ± 7
<b>LOCALIZED EXPOSURES (less than 3% of lung mass exposed)</b>							
Intravenous spheres $^{238}\text{Pu}$ 60	6,000	0.36	38 krad/yr	2/148	1 ± 1	3/148	2 ± 1
60	2,000	0.12	10 krad/yr	0/72	0 ± 1	0/72	0 ± 1
13	2,000	0.04	2 krad/yr	0/70	0 ± 1	0/70	0 ± 1
4	6,000	0.02	2 krad/yr	0/154	0 ± 0.5	9/154	6 ± 2
<b>CONTROLS</b>							
				3/220	1.4 ± 0.8	1/220	0.5 ± 0.5

<sup>a</sup>Total energy/total lung mass.

<sup>b</sup>Bronchiolar adenomatous lesions, regardless of whether graded 1+, 2+, 3+.

<sup>c</sup>N.A. = not applicable

<sup>d</sup>Maintained by weekly instillations for 7 weeks

<sup>e</sup>Low grade BAI: 1 to 2+

In this table the tumor incidence observed in hamsters in which the lungs received relatively diffuse alpha irradiation exposures is compared with the tumor incidence in hamsters given  $^{238}\text{Pu}$  microspheres which irradiated less than 3% of the lung mass. A 10-30% tumor incidence is observed in the hamsters which received relatively diffuse irradiation exposure, compared with only 1% in the group of hamsters that received  $^{238}\text{Pu}$  microspheres. No tumors were found in three other groups. This is taken by the ICR Airans staff as conclusive evidence that highly localized alpha irradiation of the lungs is less effective in causing lung tumors than more diffuse alpha irradiation. The same conclusions can be drawn from the incidences of bronchiolar adenomatous lesions. It should be noted that the  $^{238}\text{Pu}$  microspheres in all four groups qualify as "hot particles" according to Tamplin and Cochran's definitions, in that all were above 0.07 and 0.6 pCi/particle.

Table 3 Summary of Lung Tumor Incidence (LASL Data on Syrian Hamsters (14) (Provided to the NAS Committee by Dr. E. C. Anderson, Los Alamos Scientific Laboratory)

## 5. HUMAN EXPOSURES TO PLUTONIUM

Although the exact number of persons occupationally exposed to plutonium is unknown, an estimate of several thousands worldwide would not be an exaggeration. It is also reasonable to believe that only a small percentage of these received detectable body burdens. Only a relatively few exposure cases are well documented; probably those with the highest body burdens are in this group. No cases of cancer have been attributed to these plutonium exposures; nevertheless, the few documented exposure cases have been used both to support and to discredit the hot particle concept.

The first of these human exposures involved the surgical removal of a 5 nCi particle of plutonium from the palm of a man's hand about four years after it was embedded. The histological changes were described by the authors of the published report as having "a similarity to known pre-cancerous epidermal cytologic changes" (22). Tamplin and Cochran (2) pointed out the similarity of the description of this lesion to published descriptions of lesions in the

lungs of hamsters at Los Alamos containing plutonium microspheres and made inferences about the induction of lung cancer by inhaled plutonium particles. As shown in Table 3, only 2 lung tumors occurred in hamsters given plutonium particles which met Tamplin-Cochran's definitions of hot particles (greater than 0.07 or 0.6 pCi/particle). The frequency of these tumors was the same as in the controls. The tumors were a different cell type than the bronchiolo-alveolar carcinomas seen in dogs and rats after inhalation of plutonium particles. Thus, the relevance of the lesion observed in the man's hand containing 5 nCi plutonium to the induction of lung cancer by inhaled plutonium is not established.

A second human exposure incident involved the inhalation of plutonium by 25 workers at Los Alamos in 1944 and 1945. The lung burdens of all of these workers were in the range of the permissible lung burden of 16 nCi. The fact that none of these workers have shown any health consequences which can be attributed to the plutonium during the subsequent 30-plus years has been employed in arguments against the hot particle theory (7). This has been countered by claims that such negative results in a population of only 25 people prove nothing. Probably the most thorough evaluation of this point was published by Cave and Freedman (23). Using published values for the plutonium lung burdens of the Los Alamos workers and testing various assumptions about the particle size distributions of the plutonium aerosols inhaled, the authors conclude that the Tamplin-Cochran risk per particle is probably over estimated by a factor of  $10^3$  to  $10^4$ .

## 6. CONCLUSIONS

Currently knowledge about the behavior of inhaled plutonium particles in the lungs and the interaction of alpha irradiation with cells is inadequate either to completely support or deny the "hot particle" theory of the induction of lung cancer. However, animal experiments and limited experience with human plutonium contamination cases indicate that the lung cancer risk associated with inhaled plutonium particles will be greatly overestimated if based on hot particle concepts. Thus, there is no compelling evidence to support changing the current practice of averaging the radiation dose to the lungs from inhaled plutonium to a practice based on numbers of particles, size of particles or distribution of particles in the lungs.

## REFERENCES

1. EPA City of Inhaled Rad. (a) by R. W. Tamplin, M. M. Cochran, Report of the Los Alamos Scientific Laboratory, Los Alamos, New Mexico, EPL-419 (Final) (Final report, contract number 5040, first one, Agency of Biological and Environmental Research, Los Alamos, New Mexico, 1970).
2. EPA City of Inhaled Rad. (b) by R. W. Tamplin, M. M. Cochran, Report of the Los Alamos Scientific Laboratory, Los Alamos, New Mexico, EPL-420 (Final) (Final report, contract number 5040, second one, Agency of Biological and Environmental Research, Los Alamos, New Mexico, 1970).
3. EPA City of Inhaled Rad. (c) by R. W. Tamplin, M. M. Cochran, Report of the Los Alamos Scientific Laboratory, Los Alamos, New Mexico, EPL-421 (Final) (Final report, contract number 5040, third one, Agency of Biological and Environmental Research, Los Alamos, New Mexico, 1970).
4. EPA City of Inhaled Rad. (d) by R. W. Tamplin, M. M. Cochran, Report of the Los Alamos Scientific Laboratory, Los Alamos, New Mexico, EPL-422 (Final) (Final report, contract number 5040, fourth one, Agency of Biological and Environmental Research, Los Alamos, New Mexico, 1970).
5. EPA City of Inhaled Rad. (e) by R. W. Tamplin, M. M. Cochran, Report of the Los Alamos Scientific Laboratory, Los Alamos, New Mexico, EPL-423 (Final) (Final report, contract number 5040, fifth one, Agency of Biological and Environmental Research, Los Alamos, New Mexico, 1970).
6. EPA City of Inhaled Rad. (f) by R. W. Tamplin, M. M. Cochran, Report of the Los Alamos Scientific Laboratory, Los Alamos, New Mexico, EPL-424 (Final) (Final report, contract number 5040, sixth one, Agency of Biological and Environmental Research, Los Alamos, New Mexico, 1970).
7. EPA City of Inhaled Rad. (g) by R. W. Tamplin, M. M. Cochran, Report of the Los Alamos Scientific Laboratory, Los Alamos, New Mexico, EPL-425 (Final) (Final report, contract number 5040, seventh one, Agency of Biological and Environmental Research, Los Alamos, New Mexico, 1970).
8. EPA City of Inhaled Rad. (h) by R. W. Tamplin, M. M. Cochran, Report of the Los Alamos Scientific Laboratory, Los Alamos, New Mexico, EPL-426 (Final) (Final report, contract number 5040, eighth one, Agency of Biological and Environmental Research, Los Alamos, New Mexico, 1970).
9. EPA City of Inhaled Rad. (i) by R. W. Tamplin, M. M. Cochran, Report of the Los Alamos Scientific Laboratory, Los Alamos, New Mexico, EPL-427 (Final) (Final report, contract number 5040, ninth one, Agency of Biological and Environmental Research, Los Alamos, New Mexico, 1970).
10. EPA City of Inhaled Rad. (j) by R. W. Tamplin, M. M. Cochran, Report of the Los Alamos Scientific Laboratory, Los Alamos, New Mexico, EPL-428 (Final) (Final report, contract number 5040, tenth one, Agency of Biological and Environmental Research, Los Alamos, New Mexico, 1970).
11. EPA City of Inhaled Rad. (k) by R. W. Tamplin, M. M. Cochran, Report of the Los Alamos Scientific Laboratory, Los Alamos, New Mexico, EPL-429 (Final) (Final report, contract number 5040, eleventh one, Agency of Biological and Environmental Research, Los Alamos, New Mexico, 1970).
12. EPA City of Inhaled Rad. (l) by R. W. Tamplin, M. M. Cochran, Report of the Los Alamos Scientific Laboratory, Los Alamos, New Mexico, EPL-430 (Final) (Final report, contract number 5040, twelfth one, Agency of Biological and Environmental Research, Los Alamos, New Mexico, 1970).
13. EPA City of Inhaled Rad. (m) by R. W. Tamplin, M. M. Cochran, Report of the Los Alamos Scientific Laboratory, Los Alamos, New Mexico, EPL-431 (Final) (Final report, contract number 5040, thirteenth one, Agency of Biological and Environmental Research, Los Alamos, New Mexico, 1970).
14. EPA City of Inhaled Rad. (n) by R. W. Tamplin, M. M. Cochran, Report of the Los Alamos Scientific Laboratory, Los Alamos, New Mexico, EPL-432 (Final) (Final report, contract number 5040, fourteenth one, Agency of Biological and Environmental Research, Los Alamos, New Mexico, 1970).
15. EPA City of Inhaled Rad. (o) by R. W. Tamplin, M. M. Cochran, Report of the Los Alamos Scientific Laboratory, Los Alamos, New Mexico, EPL-433 (Final) (Final report, contract number 5040, fifteenth one, Agency of Biological and Environmental Research, Los Alamos, New Mexico, 1970).
16. EPA City of Inhaled Rad. (p) by R. W. Tamplin, M. M. Cochran, Report of the Los Alamos Scientific Laboratory, Los Alamos, New Mexico, EPL-434 (Final) (Final report, contract number 5040, sixteenth one, Agency of Biological and Environmental Research, Los Alamos, New Mexico, 1970).
17. EPA City of Inhaled Rad. (q) by R. W. Tamplin, M. M. Cochran, Report of the Los Alamos Scientific Laboratory, Los Alamos, New Mexico, EPL-435 (Final) (Final report, contract number 5040, seventeenth one, Agency of Biological and Environmental Research, Los Alamos, New Mexico, 1970).
18. EPA City of Inhaled Rad. (r) by R. W. Tamplin, M. M. Cochran, Report of the Los Alamos Scientific Laboratory, Los Alamos, New Mexico, EPL-436 (Final) (Final report, contract number 5040, eighteenth one, Agency of Biological and Environmental Research, Los Alamos, New Mexico, 1970).
19. EPA City of Inhaled Rad. (s) by R. W. Tamplin, M. M. Cochran, Report of the Los Alamos Scientific Laboratory, Los Alamos, New Mexico, EPL-437 (Final) (Final report, contract number 5040, nineteenth one, Agency of Biological and Environmental Research, Los Alamos, New Mexico, 1970).
20. EPA City of Inhaled Rad. (t) by R. W. Tamplin, M. M. Cochran, Report of the Los Alamos Scientific Laboratory, Los Alamos, New Mexico, EPL-438 (Final) (Final report, contract number 5040, twentieth one, Agency of Biological and Environmental Research, Los Alamos, New Mexico, 1970).
21. EPA City of Inhaled Rad. (u) by R. W. Tamplin, M. M. Cochran, Report of the Los Alamos Scientific Laboratory, Los Alamos, New Mexico, EPL-439 (Final) (Final report, contract number 5040, twenty-first one, Agency of Biological and Environmental Research, Los Alamos, New Mexico, 1970).
22. EPA City of Inhaled Rad. (v) by R. W. Tamplin, M. M. Cochran, Report of the Los Alamos Scientific Laboratory, Los Alamos, New Mexico, EPL-440 (Final) (Final report, contract number 5040, twenty-second one, Agency of Biological and Environmental Research, Los Alamos, New Mexico, 1970).
23. Cave, C. E. and Freedman, J. M., "Evaluation of the Health Consequences of the 1944-1945 Plutonium Inhalation Incident at Los Alamos," *Health, Environmental and Safety*, **1**, 1-10 (1970).
24. EPA City of Inhaled Rad. (w) by R. W. Tamplin, M. M. Cochran, Report of the Los Alamos Scientific Laboratory, Los Alamos, New Mexico, EPL-441 (Final) (Final report, contract number 5040, twenty-third one, Agency of Biological and Environmental Research, Los Alamos, New Mexico, 1970).
25. EPA City of Inhaled Rad. (x) by R. W. Tamplin, M. M. Cochran, Report of the Los Alamos Scientific Laboratory, Los Alamos, New Mexico, EPL-442 (Final) (Final report, contract number 5040, twenty-fourth one, Agency of Biological and Environmental Research, Los Alamos, New Mexico, 1970).
26. EPA City of Inhaled Rad. (y) by R. W. Tamplin, M. M. Cochran, Report of the Los Alamos Scientific Laboratory, Los Alamos, New Mexico, EPL-443 (Final) (Final report, contract number 5040, twenty-fifth one, Agency of Biological and Environmental Research, Los Alamos, New Mexico, 1970).
27. EPA City of Inhaled Rad. (z) by R. W. Tamplin, M. M. Cochran, Report of the Los Alamos Scientific Laboratory, Los Alamos, New Mexico, EPL-444 (Final) (Final report, contract number 5040, twenty-sixth one, Agency of Biological and Environmental Research, Los Alamos, New Mexico, 1970).
28. EPA City of Inhaled Rad. (aa) by R. W. Tamplin, M. M. Cochran, Report of the Los Alamos Scientific Laboratory, Los Alamos, New Mexico, EPL-445 (Final) (Final report, contract number 5040, twenty-seventh one, Agency of Biological and Environmental Research, Los Alamos, New Mexico, 1970).
29. EPA City of Inhaled Rad. (ab) by R. W. Tamplin, M. M. Cochran, Report of the Los Alamos Scientific Laboratory, Los Alamos, New Mexico, EPL-446 (Final) (Final report, contract number 5040, twenty-eighth one, Agency of Biological and Environmental Research, Los Alamos, New Mexico, 1970).
30. EPA City of Inhaled Rad. (ac) by R. W. Tamplin, M. M. Cochran, Report of the Los Alamos Scientific Laboratory, Los Alamos, New Mexico, EPL-447 (Final) (Final report, contract number 5040, twenty-ninth one, Agency of Biological and Environmental Research, Los Alamos, New Mexico, 1970).
31. EPA City of Inhaled Rad. (ad) by R. W. Tamplin, M. M. Cochran, Report of the Los Alamos Scientific Laboratory, Los Alamos, New Mexico, EPL-448 (Final) (Final report, contract number 5040, thirtieth one, Agency of Biological and Environmental Research, Los Alamos, New Mexico, 1970).
32. EPA City of Inhaled Rad. (ae) by R. W. Tamplin, M. M. Cochran, Report of the Los Alamos Scientific Laboratory, Los Alamos, New Mexico, EPL-449 (Final) (Final report, contract number 5040, thirty-first one, Agency of Biological and Environmental Research, Los Alamos, New Mexico, 1970).
33. EPA City of Inhaled Rad. (af) by R. W. Tamplin, M. M. Cochran, Report of the Los Alamos Scientific Laboratory, Los Alamos, New Mexico, EPL-450 (Final) (Final report, contract number 5040, thirty-second one, Agency of Biological and Environmental Research, Los Alamos, New Mexico, 1970).
34. EPA City of Inhaled Rad. (ag) by R. W. Tamplin, M. M. Cochran, Report of the Los Alamos Scientific Laboratory, Los Alamos, New Mexico, EPL-451 (Final) (Final report, contract number 5040, thirty-third one, Agency of Biological and Environmental Research, Los Alamos, New Mexico, 1970).
35. EPA City of Inhaled Rad. (ah) by R. W. Tamplin, M. M. Cochran, Report of the Los Alamos Scientific Laboratory, Los Alamos, New Mexico, EPL-452 (Final) (Final report, contract number 5040, thirty-fourth one, Agency of Biological and Environmental Research, Los Alamos, New Mexico, 1970).
36. EPA City of Inhaled Rad. (ai) by R. W. Tamplin, M. M. Cochran, Report of the Los Alamos Scientific Laboratory, Los Alamos, New Mexico, EPL-453 (Final) (Final report, contract number 5040, thirty-fifth one, Agency of Biological and Environmental Research, Los Alamos, New Mexico, 1970).
37. EPA City of Inhaled Rad. (aj) by R. W. Tamplin, M. M. Cochran, Report of the Los Alamos Scientific Laboratory, Los Alamos, New Mexico, EPL-454 (Final) (Final report, contract number 5040, thirty-sixth one, Agency of Biological and Environmental Research, Los Alamos, New Mexico, 1970).
38. EPA City of Inhaled Rad. (ak) by R. W. Tamplin, M. M. Cochran, Report of the Los Alamos Scientific Laboratory, Los Alamos, New Mexico, EPL-455 (Final) (Final report, contract number 5040, thirty-seventh one, Agency of Biological and Environmental Research, Los Alamos, New Mexico, 1970).
39. EPA City of Inhaled Rad. (al) by R. W. Tamplin, M. M. Cochran, Report of the Los Alamos Scientific Laboratory, Los Alamos, New Mexico, EPL-456 (Final) (Final report, contract number 5040, thirty-eighth one, Agency of Biological and Environmental Research, Los Alamos, New Mexico, 1970).
40. EPA City of Inhaled Rad. (am) by R. W. Tamplin, M. M. Cochran, Report of the Los Alamos Scientific Laboratory, Los Alamos, New Mexico, EPL-457 (Final) (Final report, contract number 5040, thirty-ninth one, Agency of Biological and Environmental Research, Los Alamos, New Mexico, 1970).
41. EPA City of Inhaled Rad. (an) by R. W. Tamplin, M. M. Cochran, Report of the Los Alamos Scientific Laboratory, Los Alamos, New Mexico, EPL-458 (Final) (Final report, contract number 5040, fortieth one, Agency of Biological and Environmental Research, Los Alamos, New Mexico, 1970).
42. EPA City of Inhaled Rad. (ao) by R. W. Tamplin, M. M. Cochran, Report of the Los Alamos Scientific Laboratory, Los Alamos, New Mexico, EPL-459 (Final) (Final report, contract number 5040, forty-first one, Agency of Biological and Environmental Research, Los Alamos, New Mexico, 1970).
43. EPA City of Inhaled Rad. (ap) by R. W. Tamplin, M. M. Cochran, Report of the Los Alamos Scientific Laboratory, Los Alamos, New Mexico, EPL-460 (Final) (Final report, contract number 5040, forty-second one, Agency of Biological and Environmental Research, Los Alamos, New Mexico, 1970).
44. EPA City of Inhaled Rad. (aq) by R. W. Tamplin, M. M. Cochran, Report of the Los Alamos Scientific Laboratory, Los Alamos, New Mexico, EPL-461 (Final) (Final report, contract number 5040, forty-third one, Agency of Biological and Environmental Research, Los Alamos, New Mexico, 1970).
45. EPA City of Inhaled Rad. (ar) by R. W. Tamplin, M. M. Cochran, Report of the Los Alamos Scientific Laboratory, Los Alamos, New Mexico, EPL-462 (Final) (Final report, contract number 5040, forty-fourth one, Agency of Biological and Environmental Research, Los Alamos, New Mexico, 1970).
46. EPA City of Inhaled Rad. (as) by R. W. Tamplin, M. M. Cochran, Report of the Los Alamos Scientific Laboratory, Los Alamos, New Mexico, EPL-463 (Final) (Final report, contract number 5040, forty-fifth one, Agency of Biological and Environmental Research, Los Alamos, New Mexico, 1970).
47. EPA City of Inhaled Rad. (at) by R. W. Tamplin, M. M. Cochran, Report of the Los Alamos Scientific Laboratory, Los Alamos, New Mexico, EPL-464 (Final) (Final report, contract number 5040, forty-sixth one, Agency of Biological and Environmental Research, Los Alamos, New Mexico, 1970).
48. EPA City of Inhaled Rad. (au) by R. W. Tamplin, M. M. Cochran, Report of the Los Alamos Scientific Laboratory, Los Alamos, New Mexico, EPL-465 (Final) (Final report, contract number 5040, forty-seventh one, Agency of Biological and Environmental Research, Los Alamos, New Mexico, 1970).
49. EPA City of Inhaled Rad. (av) by R. W. Tamplin, M. M. Cochran, Report of the Los Alamos Scientific Laboratory, Los Alamos, New Mexico, EPL-466 (Final) (Final report, contract number 5040, forty-eighth one, Agency of Biological and Environmental Research, Los Alamos, New Mexico, 1970).
50. EPA City of Inhaled Rad. (aw) by R. W. Tamplin, M. M. Cochran, Report of the Los Alamos Scientific Laboratory, Los Alamos, New Mexico, EPL-467 (Final) (Final report, contract number 5040, forty-ninth one, Agency of Biological and Environmental Research, Los Alamos, New Mexico, 1970).
51. EPA City of Inhaled Rad. (ax) by R. W. Tamplin, M. M. Cochran, Report of the Los Alamos Scientific Laboratory, Los Alamos, New Mexico, EPL-468 (Final) (Final report, contract number 5040, fiftieth one, Agency of Biological and Environmental Research, Los Alamos, New Mexico, 1970).

A CASE OF LUNG CANCER IN A MINER - AN ESTIMATION OF RADON EXPOSURE AND  
DISCUSSION OF PROBABLE CAUSES

Jan Olof Snihs and Gunnar Walinder

NATIONAL INSTITUTE OF RADIATION  
PROTECTION  
STOCKHOLM

NATIONAL DEFENCE RESEARCH  
INSTITUTE  
STOCKHOLM

Introduction

This paper describes one particular lung cancer case which was brought before the National Swedish Social Insurance Board as a possible case of industrial injury due to exposure to radon. The man (A J) concerned worked in mines during the period 1917-1944 and he was found to be suffering from lung cancer in 1961 when he was 69 years of age. A J had been a moderate smoker for the previous 20 years, he had healed lung tuberculosis and confirmed silicosis in stage 1. The two mines in which he worked have been out of use for many years and they have not been accessible for measurement of radon concentrations. The problems were to estimate the most probable exposure to radon daughters and to judge its significance for the cancer which appeared almost 20 years after A J stopped working in mines.

Estimation of the radon daughter exposure

A J had worked as a driller in two mines, in Leckomberga (Mine L) 1917-1941 and in Sörvik (Mine S) 1941-1944, altogether 27 years. From 1944 to 1954 he worked above ground in a machinery control room. Mine L was closed in the 1950s and Mine S around 1960. Since radon measurements in Swedish mines were commenced first at the end of the 1960s there are no measurements from Mines L and S to support the estimation of exposures. The estimation must therefore be made by combining data on geology, ventilation and other appropriate information about the mines found in the records, or related in interviews, with the experience from measured mines.

The reasons for the high radon levels formerly found in many Swedish mines have been presented elsewhere (1,2). The main reasons are ventilation via abandoned areas and rock waste, radon-rich water and radioactive minerals. Non-porous rock exhales less radon than porous rock. The presence of such radium-rich minerals as thucholite and pitchblende often leads to high radon levels. Pegmatite is often more radioactive than other minerals and may sometimes be a cause of high radon levels.

Near the two mines there are many mines which are still in use or which have recently been closed. In 1970 the radon daughter levels in these adjacent mines were in the range 0.3-3 WL with an average of about 1 WL. Few Swedish mines had levels exceeding 3 WL.

The geology of Mine L was very similar to that of Blötberget, an adjacent mine with a radon daughter concentration of 1-3 WL. Pegmatite was frequent, the silica content was relatively high. The mine was characterized as rather dry. The method of mining left open spaces in the mine. Down to a depth of about 30 m these spaces were filled with waste crushed rock. The total depth was about 400 m. The ventilation air was extracted via the central shaft but it not certain whether the intake air passed through the waste rock spaces.

Mine S was 130 m deep. The method of mining left open spaces as in Mine L. Mine S was a water-rich mine and it is most probable that this water con-



tained high radon levels (more than 1 nCi/l). It has not been possible to determine the details of the method of ventilation but it is probable that it resembled that in Mine L. The rock was probably somewhat porous.

From the above data and from knowledge of the causes of radon daughter levels in Swedish mines it has been possible to arrive at 1-3 WL as a reasonably trustworthy range for the levels in Mines L and S and 2 WL has been found to be the most likely value. The estimated exposure was therefore about 600 WLM with a probable range of 300-900 WLM.

#### Possible promoting agents in lung tumor induction by radon

The presence of radon and consequently of its decay products in the air is probably of decisive significance for the high frequency of bronchial carcinoma observed among the miners in certain mines. This conclusion does not exclude the possibility that other factors may make a substantial contribution.

In the normal bronchi, inhaled particles are deposited on the mucous membrane on top of the cilia and transported upwards to the pharynx. Cigarette smoking, chronic bronchitis, pneumoconiosis etc. can destroy this mechanism as well as the pseudostratified epithelium lining the bronchi and thus initiate a compensatory proliferation of the basal cells (3). Such effects increase the dose to the basal cells from the radon daughters and promote the induction of bronchial tumors. Results from animal experiments have elucidated this connection. When rats, mice and dogs have been exposed to radon and its daughters it has proved difficult or impossible to produce bronchial tumors except when this treatment has been preceded by the inhalation of irritants, e.g. quartz dust (4,5,6,7).

Several observations indicate that the induction of bronchial tumors in man after long-term inhalation of radon daughters is dependent on the damage to the walls of the respiratory tract in the same way as has been found in the case of animals. Saccomanno et al. (8,9) and Lundin et al. (10) have found that bronchial carcinomas are much more frequent among uranium miners who smoke cigarettes than among those who do not smoke. It should be pointed out that the irritants need not necessarily be carcinogenic themselves. Silicosis is not considered to be a carcinogen but the damage to the bronchial epithelium from inhaled quartz dust does increase the carcinogenic risk from the radon daughters.

The occurrence of other pulmonary diseases may also make miners more susceptible to the carcinogenic effects of radon daughter inhalation. Patients who have suffered from pulmonary tuberculosis are reported to be 5 (men) or 10 (women) times more susceptible to lung cancer than others (11). In addition, healed tuberculosis damage may also imply an increased risk of bronchial tumor induction by radon daughter inhalation, for instance if it contributes to an accumulation of the inhaled radionuclides.

#### Anamnesis

An X-ray examination in 1944 revealed an apparently healed pulmonary tuberculosis close to the upper part of the right hilus. Ten years later, pulmonary changes could be discerned by X-ray. They were diagnosed as silicosis 1 (Johannesburg). In 1957 the changes in the right lung were marked with granular and streaky condensations connected with the hilus. Furthermore, signs of bronchiectasis and atelectasis were found in the upper part of the right lobe. A further development of the pulmonary changes, particularly the condensed parts around and from the right pulmonary hilus occasioned an examination of the supraclavicular lymph nodes in 1961. This examination revealed metastases from a pulmonary carcinoma of "oatcell" type and pneumoconiosis (possibly silicosis).

In summary, 1917: commencement of mining. 1941: commencement of cigarette smoking (10/day), 1944: X-ray examination (diagnosis: healed pulmonary tuberculosis in the right hilus region) and termination of mining. 1954: X-ray examination (diagnosis: silicosis I). 1961: Daniels biopsy. Diagnosis: carcinoma (oatcell) with metastases. 1962: A J died.

In this case, there are 4 factors which might have been of significance to the tumor induction: (a) Inhalation of radon daughters, (b) pulmonary tuberculosis, (c) cigarette smoking, (d) pneumoconiosis (silicosis).

The late appearance of the mitigated form of silicosis can hardly be considered an essential contribution factor to the tumor induction. A similar remark can be made with regard to the cigarette smoking. Cigarettes indubitably imply a risk of lung cancer, but the late commencement and the moderate smoking habits of AJ should constitute a lower risk than a lifelong and extensive use of tobacco.

The healed tuberculosis cannot, however, be ruled out as an etiologic factor, especially since the X-rays indicate that the tumor arose in the area where the healed tuberculosis was first seen in 1944. As shown in Table 1, tuberculosis may imply a risk of lung cancer which is about 5 times higher than the normal frequency for men of 45-64 years of age. According to our calculation A J received a radon daughter exposure of about 600 WLM. This exposure would imply a risk of lung cancer that is about 5 times higher than the normal frequency for men of 30-70 years of age and somewhat less than 2 times higher than that for 65-70 year-old men. These figures may be somewhat high in the case of A J in view of his moderate smoking habits. The carcinoma found in A J was of "oatcell" type which is a histological type not uncommon among miners (and cigarette smokers). Its relative frequency seems to be between 30 and 50 % and this has a tendency to increase with increasing radiation dose.

TABLE 1. SOME ETIOLOGICAL FACTORS IN THE INDUCTION OF PULMONARY CARCINOMA

Etiological factor	Country	Age, years	Rate per year x)		Ref.
			per 100,000	Rate Mean rate	
Non-smoker	USA	50 - 70	3.4	0.079	12
Mean values for the male population	USA	50 - 70	44.5	1	12
10 cigarettes/day	USA	50 - 70	51.4	1.2	12
20-40 cigarettes/day	USA	50 - 70	143.9	3.2	12
40 cigarettes/day	USA	50 - 70	217.3	4.9	12
Mean values for the male population	Sweden	30 - 70	35.0	1	13
- " -	Sweden	45 - 65	45.6	1	13
- " -	Sweden	50 - 70	70.6	1	13
- " -	Sweden	65 - 70	124.5	1	13
Tuberculosis	Israel	45 - 65	159	5.2	11
Heavy smokers	Israel	45 - 65	131	4.3	11
600 WLM radon	USA	26 - 60+	189	5.4	14
700 WLM radon	Sweden	30 - 65	200	7.8	1

x) The upper 5 values from USA are death rates, the others incidence rates.

## Conclusion

The radon daughter exposure is estimated to have been about 600 WLM. In the absence of synergistic effects, this exposure would not be high enough to make it stand out as the most probable cause of the lung cancer. However, in view of the tuberculosis history of this particular person it is not unreasonable to assume that the tumorigenic risk from the radon daughters was enhanced and that as a result the radon daughter exposure in this case played a significant role in the development of the cancer.

## References

1. SNIHS J.O., The approach to radon problems in non-uranium mines in Sweden. Proceedings of the third international congress of the International Radiation Protection Association, Sept.9-14, 1973, Washington, D.C. pp. 900-912, U.S. Atomic Energy Commission, Office of Information Services, Technical Information Center Oak Ridge, Tennessee, 1974.
2. SNIHS J.O., The significance of radon and its progeny as natural radiation sources in Sweden. Proceedings of Noble Gases symposium in Las Vegas, U.S.A. Sept.24-28, 1973, pp.115-130. U.S Environmental Protection Agency.
3. KOTIN P., COURINGTON D. and FALK H.L., Pathogenesis of cancer in a ciliated mucus-secreting epithelium. J. Occ. Med. 15 (1973), 204.
4. KUSHNEVA V.S. The experimental effects of combined quartz dust and radon. In: Toxicology of Radioactive Substances. Vol.1. Perg.Press. 1962.
5. KILIBARDA M, VISNJIC V, PANOV D, RADOVANOVIC R, and NOVAK L : Deposition of some radon daughters in rats after inhalation of radon, with special consideration of the stimulus influence of SiO<sub>2</sub>. In: Diagnosis and Treatment of Deposited Radionuclides. Excerpta Medica Foundation, p.222, 1967.
6. PERRAUD R, CHAMEAUD J, MASSE R, and LAFUMA J.: Cancers pulmonaires experimentaux chez le rat après inhalation de radon associé à des poussières non radioactives. C.R Acad.Sci. 270, 2594. Paris 1970.
7. MORKEN D.A.:The biological effects of radon. USAEC, UR-3400-384, 1973.
8. SACCOMANNO G., ARCHER V.E., SAUNDERS R.P., JAMES L.A. and BECKLER P.A.: Lung cancer of uranium miners on the Colorado plateau. Health Physics 10 (:1964). 1195.
9. SACCOMANNO G.:Uranium miner lung cancer study. COO-1826-28, 1974.
10. LUNDIN F E, LLOYD J W, SMITH E M, ARCHER V E, and HOLADAY D A: Mortality of uranium miners in relation to radiation exposure, hard-rock mining and cigarette smoking-1950 through September 1967. Health Physics 16 (1969), 571.
11. STEINITZ R: Pulmonary tuberculosis and carcinoma of the lung. Am.Rev. Resp. Dis. 92 (1965), 758.
12. HAMMOND E.C. and HORN D.:J.A.M.A. 166 (1958), 1294.
13. Cancer incidence in Sweden 1959-1965. National Board of Health and Welfare. The Cancer Registry. Stockholm 1971.
14. Report to the Advisory Committee on the biological effects of ionizing radiation. Washington D.C. 1974 (BEIR-report).

AN ANALYSIS OF LEUKEMIA DATA FROM STUDIES OF ATOMIC-BOMB SURVIVORS  
BASED ON ESTIMATES OF ABSORBED DOSE TO ACTIVE BONE MARROW\*

G. D. Kerr,<sup>†</sup> T. D. Jones, J. M. L. Hwang<sup>‡</sup> K. L. Miller,<sup>§</sup> and J. A. Auxier<sup>†</sup>

Health Physics Division  
Oak Ridge National Laboratory  
Oak Ridge, Tennessee 37830  
United States of America

**ABSTRACT:** Leukemia data from studies of atomic-bomb survivors have been investigated using new calculations of absorbed dose to active bone marrow of a Japanese adult for radiation fields similar to those experienced by the survivors. These investigations provide important new refinements in the estimation of leukemic risk factors for neutrons. The lifetime risk of leukemia for neutrons is estimated to be of the order of 600 cases per million person-rads of high LET-absorbed dose to active marrow, and the lifetime risk for gamma rays is estimated to be of the order of 30 cases per million person-rads of low LET-absorbed dose at low dose levels.

## 1. INTRODUCTION

Estimates of radiation dose, denoted as T65D, are available for 79,113 atomic-bomb survivors included in the important *Life Span Studies* [1,2] of the Radiation Effects Research Foundation (RERF), formerly the Atomic Bomb Casualty Commission (ABCC). Although the locations reported by survivors and shielding provided by structures or terrain were taken into account in the T65D estimation of dose, these estimates predict only a survivor's radiation exposure in terms of tissue kerma in air [3] and neglect, therefore, the self-shielding of internal organs by the survivor's body [4].

Self-shielding factors for active bone marrow have been calculated recently at the Oak Ridge National Laboratory (ORNL), and these calculations have shown that absorbed doses to active marrow of survivors vary markedly from the T65D estimates [5]. For an adult Japanese survivor [6], the ratio of the low LET-absorbed dose in active marrow to tissue kerma in air from gamma rays has been calculated to be 0.56, while the self-shielding factors or ratios of high LET-absorbed dose from neutron recoil particles and low LET-absorbed dose from neutron capture gammas to tissue kerma in air from neutrons have been calculated to be 0.28 and 0.067, respectively.

## 2. DOSE-RESPONSE OF LEUKEMIC INCIDENCE

Incidence rates in cases/ $10^6$  person-years based on 1950-72 data of mortality from leukemia are shown in Table 1 for Hiroshima and Nagasaki survivors with T65D estimates in the ranges 0-9, 10-49, 50-99, 100-199, 200-399, and 400-599 rads. A further breakdown in:

---

\* Research sponsored by the Energy Research and Development Administration under contract with Union Carbide Corporation.

† Consultant to the Radiation Effects Research Foundation, Hiroshima and Nagasaki, Japan.

‡ Consultant from the University of Tennessee, Knoxville, Tennessee.

§ Consultant from Computer Sciences Division, General Staff, Union Carbide Corporation, Oak Ridge, Tennessee.

Table 1 of data on the 200+ rad grouping of survivors in the *Seventh Life Span Study Report* [2] was provided through the courtesy of I. M. Moriyama and H. Kato of the RERF. Estimation of absorbed dose to active marrow from the mean T65D values in Table 1 of tissue kerma for gamma rays,  $K_\gamma$ , and neutrons,  $K_n$ , is illustrated for the 100-199 rad group in Hiroshima. For a survivor in this T65D group, the mean value of the high LET-absorbed dose from neutrons,  $D_n$ , is  $0.28 K_n = 0.28 (30.1 \text{ rads}) = 8.4 \text{ rads}$ , and the mean value of the low LET-absorbed dose from gamma rays,  $D_\gamma$ , is  $0.56 K_\gamma + 0.067 K_n = 0.56 (108.5 \text{ rads}) + 0.067 (30.1 \text{ rads}) = 62.6 \text{ rads}$ . In comparison,  $D_\gamma$  and  $D_n$  are 80.9 and 0.4 rads, respectively, for Nagasaki survivors with T65D estimates of 100-199 rads. Radiation exposures in Nagasaki were almost exclusively due to gamma rays, while both neutrons and gamma rays contributed significantly to radiation exposures in Hiroshima.

The BEIR Committee of the National Academy of Sciences - National Research Council [7] has reviewed the *Life Span Studies* and suggested that incidence rates of the 0-9 rad groupings of survivors be used as controls. These were used to obtain excess incidence rates,  $Y_e$ , in the higher T65D exposure groups in each of the two cities, and  $Y_e$  values for the two cities were fitted simultaneously by the method of least squares to each of the following dose-response functions:

$$Y_e \left\{ \begin{array}{l} = A_1 D_n + B_1 D_\gamma \quad (1) \\ = A_2 D_n + B_2 D_\gamma + C_2 D_\gamma^2 \quad (2) \\ = A_3 D_n + C_3 D_\gamma^2 \quad (3) \end{array} \right.$$

Coefficients giving the best fit of  $Y_e$  to the  $D_\gamma$  and  $D_n$  values for each exposure group, and standard deviations of these coefficients, are:  $A_1 = 1.6 \pm 0.6$ ,  $B_1 = 3.6 \pm 0.5$ ;  $A_2 = 2.0 \pm 0.4$ ,  $B_2 = 0.26 \pm 0.89$ ,  $C_2 = 0.015 \pm 0.004$ ; and  $A_3 = 2.0 \pm 0.3$ ,  $C_3 = 0.016 \pm 0.002$ . Units of the A's and B's are cases/yr/ $10^6$  person-rads, and the C's have units of cases/yr/ $10^6$  person-rads<sup>2</sup> of absorbed dose to active bone marrow. Equation 1, which predicted a constant RBE of about 5 for neutrons, gave the poorest fit, and Equation 3, which predicted an RBE of about 40  $D_n^{-1}$ , gave the best fit to the data.

More important, however, is the result that the neutron risk factor is nearly independent of the assumptions regarding the gamma-ray dose response and is within the range of 1.6 to 2.0 cases/yr/ $10^6$  person-rads of high LET-absorbed dose to active marrow from neutrons. While the results suggest a curvilinear dose response to the low LET-absorbed dose from gamma rays, it is impossible to obtain an accurate estimate of the gamma-ray risk factor at low doses by fitting dose-response functions to the data. This is illustrated by the large uncertainty in the coefficient,  $B_2$ , of the linear dose term for gamma rays in Equation 2.

### 3. PERSON-REM ESTIMATES OF RISK

Fitting of dose-response functions to data on exposed groups of individuals is not required in the person-rem computations of risk by the BEIR Committee. Instead, the excess incidence rate of an observed effect is simply divided by dose equivalent to the critical organ averaged over all individuals in the exposed group. Dose equivalents for atomic-bomb survivors used in the BEIR Report are based, however, on mean T65D values of tissue kerma in air, rather than mean absorbed doses to critical organs—testes and ovaries for genetic effects, active bone marrow for leukemia, etc. Person-rem estimates of leukemia risk derived in the BEIR Report (Table a-7, p. 117) from data on *adult* survivors aged 10 or older at the time of exposure in 1945 were revised by the relationship:

$$\text{Risk} = Y_e / D_y + \text{RBE} \cdot D_n \quad (4)$$

These revisions are given in Table 2. Groupings of adult survivors with T65D estimates of 0-9 rads were used to obtain the excess incidence rates in the 10+ rad groupings of adult survivors, and the mean values of tissue kerma in air for these 10+ rad groupings of adult survivors were used to calculate the mean absorbed doses to active marrow.

An RBE of 20 to 30 brings the person-rem estimates of risk from data on survivors in the two cities into reasonable agreement, and predicts risk factors of the order of 18 to 27 cases/yr/10<sup>6</sup> person-rads of high LET-absorbed dose from neutrons and 0.86 to 1.2 cases/yr/10<sup>6</sup> person-rads of low LET-absorbed dose from gamma rays. Although the revised BEIR estimates of risk in Table 2 are from the 1950-70 data of mortality from leukemia in the *Sixth Life Span Study Report* [1] by S. Jablon and H. Kato, the results are essentially the same as those obtained from 1950-72 data on adult survivors in the *Seventh Life Span Study Report* [2]. The results in Table 2 also do not differ significantly from those obtained using data on survivors of all ages at the time of exposure in 1945. This does not imply that very young survivors are not more radiosensitive than adult survivors, but simply implies that the small number of very young survivors does not have a significant influence on the overall data of mortality from leukemia. The revised values of leukemic risk in cases/yr/10<sup>6</sup> person-rads of absorbed dose to active marrow of 0.86 to 1.2 for gamma rays from data on atomic-bomb survivors are in good agreement with the values of 0.88 to 1.3 derived by the BEIR Committee from data on x-ray-treated spondylitis and hemorrhagia patients.

#### 4. DISCUSSION

A recent review of leukemia and related disorders in survivors by M. Ichimaru and T. Ichimaru [8] presents evidence that the leukemic latency period is dependent, to some extent, upon the age at time of exposure. Leukemia in groups aged less than 15 and 15-29 at the time of exposure peaked in the early period 1950-54 and declined rapidly to normal. In groups aged 30-44 and 45 or more, leukemia peaked later and remained above normal in recent years. The 1950-72 mortality data does not represent, therefore, the total risk to survivors in the older age groups. Some of the total risk to younger age groups of survivors in the period 1945-50 also is not included in the 1950-72 data. For these reasons, it was assumed that the risk factors for the period 1950-72 were representative of the average annual risk over a slightly longer 30-year period starting in 1945. This period plus the mean age of about 35 years for survivors in 1945 is nearly equal to the normal lifetime expectancy.

Lifetime risks of leukemia ranging from 500 to 800 cases/10<sup>6</sup> person-rads of high LET-absorbed dose from neutrons were predicted by our dose-response and person-rem analyses of the leukemia data on the atomic-bomb survivors. The best estimate of the lifetime risk for neutrons from these analyses appears to be 600 cases/10<sup>6</sup> person-rads based on a 30-year average annual risk of the order of 20 cases/yr/10<sup>6</sup> person-rads of high LET-absorbed dose to active marrow, and the best estimate of the lifetime risk for gamma rays at low dose levels appears to be 30 cases/10<sup>6</sup> person-rads of low LET-absorbed dose to active marrow. This lifetime risk for gamma rays is based on a 30-year average annual risk of the order of one case/yr/10<sup>6</sup> person-rads of low LET-absorbed dose obtained in our person-rem analyses of the leukemia data on the atomic-bomb survivors.

REFERENCES

- [1] JABLON, S., and KATO, H., *Radiation Res.* 50, 649 (1972).
- [2] MORIYAMA, I. M., and KATO, H., *ABCC Report* TR 15-73 (1973).
- [3] AUXIER, J. A., *J. Radiation Res.* 16, Suppl., 1 (1975).
- [4] JONES, T. D., AUXIER, J. A., CHEKA, J. S., and KERR, G. D., *Health Phys.* 28, 367 (1975).
- [5] JONES, T. D., *ORNL Report* 5997 (September, 1976).
- [6] KERR, G. D., HWANG, J. M. L., and JONES, H. M., *J. Radiation Res.* 17, 211 (1976).
- [7] *Report of the Advisory Committee on the Biological Effects of Ionizing Radiations*, NAS-NRC, Washington, D.C. (November, 1972).
- [8] ICHIMARU, M., and ISHIMARU, T., *J. Radiation Res.* 16, Suppl., 89 (1975).

Group	Mean Dose (Rads)		Number of Persons	Person Years of Observation	Cases of Leukemia	Cases per Million Person-Years
Age at Entry	A	B				
<b>Hiroshima</b>						
0-10	1.5	3.3	43,753	865,810	37	42.8
11-20	2.0	4.4	29,977	492,318	17	33.1
21-30	2.5	5.4	2,161	35,990	7	192.0
31-40	108.6	33.1	1,772	29,560	17	568.0
41-50	21.8	65.0	907	15,111	16	1061.9
51-60	34.6	101.9	276	4,579	7	1527.6
<b>Nagasaki</b>						
0-10	2.2	---	11,424	188,947	11	58.1
11-20	21.8	---	1,027	17,479	4	227.0
21-30	21.1	2.9	1,131	36,946	0	0
31-40	211.0	1.1	1,133	19,176	3	157.4
41-50	133.2	1.0	762	12,582	2	158.4
51-60	260.7	0.5	202	3,321	1	301.5

There are an additional 117 survivors in Hiroshima (13 cases of leukemia) and 114 survivors in Nagasaki (10 cases of leukemia) with OBE estimated in excess of 200 Rads.

TABLE 1. Leukemic Incidence Rates Based on 1950-72 Data of Mortality from Leukemia in Atomic-Bomb Survivors

Group	Type of Radiation	Survival Fraction After Exposure (Year)	Mean Dose (Rads)	Mean Age at Exposure (Year)	RBE	Cases/Year/10 <sup>6</sup> Person-Years		
						Best Estimate	Lower 95% C.I.	Upper 95% C.I.
Hiroshima	gamma	0-25	2.0	25	1	0.7	2.2	1.3
					4	0.7	1.7	2.7
					10	1.7	1.2	2.1
					20	1.8	0.84	1.5
					36	0.75	0.71	1.1
Nagasaki	gamma	0-25	2.2	25	1	4.2	3.0	6.0
					4	2.8	2.1	3.3
					10	2.7	1.5	2.4
					20	1.2	0.84	1.5
					35	0.69	0.68	1.1
Hiroshima	gamma	0-25	2.0	25	1	1.0	0.16	1.8
					4	0.99	0.16	1.8
					10	0.95	0.15	1.7
					20	0.91	0.11	1.6
					45	0.85	0.14	1.5

TABLE 2. Person-Rem Estimates of Leukemic Risk Based on 1950-72 Data of Mortality from Leukemia in Atomic-Bomb Survivors of Hiroshima (H) and Nagasaki (N)

CANCER RISK ESTIMATES AND NEUTRON RBE BASED ON HUMAN EXPOSURES<sup>†</sup>

John W. Baum  
 Brookhaven National Laboratory  
 Upton, New York U.S.A. 11973

## 1. INTRODUCTION

It was recognized in both the UNSCEAR (1) and BEIR (2) Committee reports that risk estimates deduced from the Japanese data should eventually be made using absorbed dose in organs of interest rather than tissue kerma in free air (kerma for short in the following); however, the detailed calculations of appropriate doses had not been completed at the time of issue of those reports. Recent reports (3-5) of the Oak Ridge National Laboratory group provide data on absorbed doses for various phantoms and organs of interest. Auxier, et al. (4) pointed out the implications of these data for risk estimates. More recently, Rossi (7), Kerr and Jones (8) and Beebe, et al. (9) have employed the newer dose data to deduce risk estimates and RBE values. The purpose of the present work is to provide a further analysis which stresses (a) the importance of careful selection of an appropriate control group, (b) the importance of making lifetime risk estimates for total malignancies, and (c) the uncertainties involved in these estimates.

## 2. DOSE ESTIMATES AND UNCERTAINTIES

Based on the data of Jones (5) and Jones, et al. (3) it is estimated that the dose to bone marrow is approximately 55% of the kerma value for gamma and about 25% of the kerma value for the fission neutron exposures. It is further assumed that bone marrow doses are an adequate measure of mean dose to organs of importance in the analysis of total malignancies.

These estimates apply for neutrons with 2.5 MeV effective energy, incident semi-isotropically on the ICRP adult reference man. Estimated mean bone marrow doses due to neutrons may be 20% lower if effective neutron energy is 1 MeV rather than 2.5 MeV. However, neutron doses may be 75% higher if irradiation is more nearly 1/2 semi-isotropic and 1/2 bilateral. Also, dose to kerma ratios are probably somewhat higher for typical Japanese persons than for ICRP standard man due to their somewhat smaller size.

For gamma rays, the uncertainty in gamma energy is less important, however, bilateral vs. isotropic exposure has an effect very similar to that for neutrons. Thus, the risk factors deduced below are uncertain by at least 40% due to uncertainties in exposure conditions and dosimetry. The dose to organs of interest may also differ from mean bone marrow dose by a comparable factor.

## 3. EPIDEMIOLOGIC DATA AND UNCERTAINTIES

Listed on Table 1 are [1] exposure groups with exposure ranges expressed in kerma, based on 1965 estimates of kerma for a small mass of tissue in air; [2] and [3] the related mean kerma and mean bone marrow doses due to gamma and neutrons (based on above assumptions); [4] and [5] the observed and expected cases of leukemia and other malignancies; [6] a calculated value of total person-rem for each exposure group; and [7] and [8] estimated values of expected excess leukemia and malignancy deaths for the period 1950-72. Kerma values are taken from the report by Jablon and Kato (10). The products (persons x rem) were obtained using number of persons in each group (10) and applying a quality factor of 10 to the neutron component of dose. Observed and expected cases are based on 1967 Japanese mortality rates taken from the report of Moriyama and Kato (6).

<sup>†</sup> Work done at Brookhaven National Laboratory under contract with the U.S. Energy Research and Development Administration.



A comparison of the ratios of expected excess cases to uncertainty leads to the important conclusion that 1-9 kerma groups in both cities and the 10-49 kerma Nagasaki group have "signal to noise" ratios which are too small to be of value in deducing induction rate constants. The 50-99 rad (kerma) Nagasaki group is also weak, but not as seriously. From the relatively large (+19%) differences in the observed/expected ratios for the not in the city early entry (NIC-EE), not in the city late entry (NIC-LE), 0, and 0-9 kerma groups, it is clear that control group fluctuations can introduce large uncertainties into the final results. Unfortunately, similarly large uncertainties are introduced by the use of national rates as controls since total malignancy rates typically vary by +20% from region to region within a given country. For these reasons I have estimated risk coefficients using a variety of control groups and various time periods in order to demonstrate the magnitudes of the differences which result.

#### 4. RISK ESTIMATES FOR GAMMA EFFECTS

Gamma induction rates were deduced for the Nagasaki data shown on Table 1. The data must be examined carefully to appreciate the small size of the observed effects and the relatively great effect the lowest exposure group, 0-9 kerma, has on the data interpretation. If 1967 national rates are used as controls, the 0-9 kerma group shows a significant increase in leukemia over the expected number of cases (11 vs. 6.3). On the other hand, if one uses the 0-9 kerma group as controls, there is no apparent increase over expected until exposures of 100-199 kerma (doses of about 80 rad) were received. The function which best fits these data depends strongly on which control group is employed. If a power function is fitted to the data, it can have exponents less than or greater than one depending on the choice of control group. This illustrates the lack of confidence one must have in fitting equations to this data. Similar problems apply to total malignancy data for Nagasaki.

Since too few cases have been observed to make a very meaningful analysis of the shape of the dose effect curve, the data have been summed in terms of total person-rads and total excess cases of leukemia using various groups as controls. This procedure has some justifications for purposes of risk estimate in that exposed populations are also likely to receive a range of doses. Thus, the deduced risk estimates tend to reflect average effects on populations receiving acute doses from about 1 to 200 rad to bone marrow. The effects of low dose rates may be much less, however, apparent effects detected in the 1-9 kerma group do not support this expectation.

Results of these analyses are summarized in Table 2. Leukemia risks of .3 to .45 deaths per  $10^4$  person-rads are indicated for the periods 1950-72. Also listed in Table 2 are values which are predicted as lifetime risks. These values are 1.75 times the value observed between 1950-72 for leukemia since only 1/4 of the exposed population had died to date and the remaining population is still showing signs of elevated leukemia rates, however at about 1/4 the rate observed during the first ten years of observation (1950-60).

Results for total malignancies less leukemia yielded gamma risk estimates which varied from not significant (1 sigma level) to 1.8 deaths per  $10^4$  person-rad bone marrow dose based on observations from 1950-72. Since only 1/4 the exposed population has died, and since total cancer rates are not decreasing with time, it is estimated that total lifetime risks may be four times the above values. The most likely values for lifetime gamma risk coefficients are thought to be 0.67 leukemia deaths, 0.92 other malignancy deaths or a total of 1.6 malignancy deaths per  $10^4$  person-rad based on the 0-49 kerma Nagasaki groups as controls. The leukemia estimate is about 2.2 times the BEIR Committee estimate and the total malignancy estimate about 0.9 times (2). However, since estimated induction rates are about four times higher if national

rates were used as controls, a large uncertainty must be associated with these values.

#### 5. RISK ESTIMATES FOR NEUTRON EFFECTS

Hiroshima data employed in this analysis (6) are shown in Table 1 and have considerably better statistical significance than the Nagasaki data. The neutron dose-effect relation for total malignancies less leukemia obtained from the Hiroshima data follows a dose<sup>0.4</sup> function if national rates are employed as controls or an approximately linear function if the zero rad group is employed as controls.

Deduced neutron risk coefficients listed in column 4 of Table 2 were derived after correcting the observed excess deaths by an amount determined from the total person-rad gamma dose and the corresponding gamma risk coefficient listed in column 3 of Table 2. RBE values listed in column 5 were obtained from the ratios of neutron to gamma risk coefficients. Values for lifetime risks were obtained as before by multiplying the observed excess to date by 1.75 for leukemia and by four for total malignancies. Total risk per rad for gamma and neutron doses were then obtained by summing the values for leukemia and total malignancies less leukemia. Final lifetime risk values thus obtained for neutron exposures are 7.9 leukemia and 96 other malignancy deaths per 10<sup>4</sup> person-rad based on national rates as controls, or 6.3 leukemia and 24 other malignancy deaths based on low dose control rates. These values yield an overall RBE of 9 to 10 for leukemias, 20 to 26 for other malignancies or 19 for all malignancies combined.

#### 6. CONCLUSIONS

The principal uncertainties in the above analysis are a factor of about four attributable to effects which may yet occur in the surviving population and a factor of about four due to uncertainties associated with selection of a suitable control group. Uncertainties in relevant doses are probably less than a factor of two.

#### REFERENCES

- (1) UNSCEAR (1972). Ionizing Radiation: Levels and Effects, Vol. II: Effects (United Nations, New York).
- (2) BEIR (1972). The Effects on Populations of Exposure to Low Levels of Ionizing Radiation (National Academy of Sciences, Washington, D.C.).
- (3) JONES, T.D., AUXIER, J.A., CHEKA, J.S. and KERR, G.D. (1975). Health Physics 28, 367.
- (4) JONES, T.D. (1976). ORNL/TM-5337 (Oak Ridge National Laboratory, Oak Ridge, Tennessee).
- (5) JONES, T.D. (1976). ORNL-5191 (Oak Ridge National Laboratory, Oak Ridge, Tennessee).
- (6) MORIYAMA, I.M. and KATO, H. (1973). Mortality experience of A-bomb survivors 1970-72, 1950-72 (Atomic Bomb Casualty Commission, Hiroshima, Japan).
- (7) ROSSI, H.H. (1976). The effects of small doses of ionizing radiation: fundamental biophysical characteristics (Columbia University, New York).
- (8) KERR, G.D. and JONES, T.D. (1976). A reanalysis of leukemia data on atomic bomb survivors based on estimates of absorbed dose to bone marrow (Oak Ridge National Laboratory, Oak Ridge, Tennessee).
- (9) BEEBE, G.W., KATO, H. and LAND, C.E. (1976). Mortality experience of A-bomb survivors, 1950-1974 (Radiation Effects Foundation, Hiroshima 730, Japan).
- (10) JABLON, S. and KATO, H. (1972). Radiation Research 50, 649.

Table 1. Exposures, Doses, and Observed and Expected Deaths Due to Leukemia or Total Malignancies.

Kerma <sup>d</sup> RANGE	Kerma <sup>d</sup> and (dose) <sup>e</sup>		Leukemia Obs/Exp	Malign. less Leukemia <sup>b</sup> Obs/Exp	Persons x rem (10 <sup>6</sup> )	Expected Excess Leukemia	Expected Excess Total Malignancies
	Gamma	Neutron					
<u>HIROSHIMA</u>							
200+	265 (148)	54 (24.4)	78/0.9 = 73	91/54.3 = 1.66	57	17 ± 4.2	103 ± 13
100-199	139 (80)	30 (7.8)	12/1.0 = 12	89/70.3 = 1.26	23	6.9 ± 2.8	42 ± 11
50-99	57 (31)	13.3(7.5)	7/1.5 = 4.6	38/116 = 1.19	17.6	5.3 ± 2.6	32 ± 12
10-49	17.6 (10)	4.3(1.1)	17/6.2 = 2.8	501/448 = 1.12	77.5	6.7 ± 3.6	41 ± 23
1-9	2.9 (1.6)	0.8(.22)	37/75 = 1.5	1298/1193 = 1.09	5.1	1.5 ± 5.1 <sup>c</sup>	9.2 ± 23 <sup>c</sup>
0	~0	~0			~0		
NIC=EE	0	0	170/185 = 0.92		0	0	0
NIC=LE	0	0	10/11.5 = 0.88	585/580 = 1.02	0	0	0
<u>NAGASAKI</u>							
200+	329 (181)	3.6 (1.5)	15/0.7 = 20	46/35.5 = 1.29	24	7.1 ± 2.8	43 ± 8.8
100-199	146 (73)	1.4 (.36)	3/0.7 = 4.30	36/25.6 = 1.01	3.8	2.9 ± 1.9	16 ± 7.3
50-99	70 (33)	0.2 (.05)	0/0.7 = 0	65/19.3 = 1.15	4.8	1.4 ± 1.4	8.3 ± 6.9
10-49	21.1(11.7)	~0	2/2 = 1.0	122/119 = 1.08	4.4	1.3 ± 1.8	8.0 ± 11.8
1-9	4.0 (2.0)	~0	11/6.3 = 1.74	22/202 = 0.15	1.47	0.4 ± 7.6 <sup>c</sup>	7.6 ± 14 <sup>c</sup>
0	~0	~0		136/143 = 0.95	~0		
NIC=EE	0	0	4/3.6 = 1.11	40/32.7 = 1.19	0	0	0
NIC=LE	0	0		172/158 = 1.09	0	0	0

a. Person-rem calculated assuming a quality factor of 10 for neutrons.  
 b. Expected values calculated assuming the BEIR Committee estimates of 0.3 leukemias or 1.8 total malignancies per 10<sup>6</sup> person-rem; 1 value is 1 - statistical fluctuations expected based on sum of excess plus national rates.  
 c. Uncertainties larger than expected excess.  
 d. Kerma for tissue in air, units of 300 erg/gm.  
 e. Mean bone marrow dose is given in parentheses, units of rads.

Table 2. Summary of Risk Estimates.

Years	Control <sup>a</sup>	Gamma induced Deaths per 10 <sup>6</sup> rad	Neutron induced Deaths per 10 <sup>6</sup> rad	BSE
<u>LEUKEMIA</u>				
50-64	National Rate	0.35	4.1	12
50-64	0-9	0.31	2.7	8
50-72	National Rate	0.45	4.5	10
50-72	0-9	0.30	4.5	15
50-72	{0-49 (Nagasaki)	0.70	3.6	9.5
	{0-9 (Hiroshima)			
Lifetime	National Rate	0.78	7.5	10
Lifetime	{0-49 (Nagasaki)			
	{0-9 (Hiroshima)	0.67	6.3	9.5
<u>MALIGNANT NEOPLASMS LESS LEUKEMIA</u>				
65-69	National Rates	0.8 <sup>b</sup>	5.0	6.0
55-65	0-9	0.13	3.3	25 <sup>b</sup>
65-72	National Rates	1.2	4.0	3.3
50-72	National Rates	1.2	74	20
50-72	0-9	0.26 <sup>b</sup>	6.3	26 <sup>b</sup>
50-65	0	1.4	<0 <sup>b</sup>	0 <sup>b</sup>
50-72	0	1.8	<0 <sup>b</sup>	0 <sup>b</sup>
50-72	{0-49 (Nagasaki)	0.23	5.9	26
	{0-9 (Hiroshima)			
Lifetime	National Rates	4.9	96	20
Lifetime	{0-49 (Nagasaki)			
	{0-9 (Hiroshima)	0.92	24	26
<u>ALL MALIGNANT NEOPLASMS</u>				
Lifetime	National Rates	5.6	104	19
Lifetime	{0-49 (Nagasaki)			
	{0-9 (Hiroshima)	1.6	20	19

a. Numbers refer to exposure group, Kerma in 100% of ergs/gm.  
 b. Lacks statistical significance.

HEAD AND NECK TUMORS AND IMPAIRED MENTAL  
FUNCTION FOLLOWING SCALP IRRADIATION

B. Modan, E. Ron, A. Werner  
Chair Sheba Medical Center, Tel Hashomer  
Tel Aviv University Medical School &  
I. Yaar  
Hadassah Medical School, Jerusalem, Israel

This is an updated report on a long-term follow-up of delayed radiation effects among persons treated by x-ray for scalp ringworm. The study population consists of 27,084 Israelis: 10,842 cases who received x-ray treatment between 1948-1960 (1-15 years old at the time of treatment) and two control groups (non-irradiated, and not infected with ringworm). One group is comprised of 10,842 individuals matched to the cases on sex, age and ethnic background (Population Controls) while the second control group is made up of 5,400 siblings of the cases, matched on age only (Sibling Controls). The original records show that the standard Adamson-Kienbock (1) procedure was used throughout Israel. The scalp was divided into five fields and each field was exposed to 350-400 R on one out of five consecutive days. The four fields not to be treated on that day plus the face and neck were shielded with lead rubber.

Retrospective studies demonstrated that the average dose to the brain was 140 rads and to the thyroid 6-9 rads per course of treatment (2). These results are almost identical to those obtained in a similar study in New York City and by an independent physicist at the Bureau of Radiologic Health, USPHS in Rockville, Maryland (3,4).

In a previous report (5), a significant excess of head and neck tumors, found among the irradiated cases was detailed (Table 1). Of particular interest was the six-fold increase of thyroid neoplasms. This was unexpected, in view of the low dose reaching that organ.

TUMOR SITE	IRRADIATED CASES		POPULATION CONTROLS		SIBLING CONTROLS	
	No.	Rate/ 1000	No.	Rate/ 1000	No.	Rate/ 1000
<u>HEAD &amp; NECK</u>						
THYROID	12	1.1	2	0.2	1	0.2
PAROTID	4	0.4	0	0.0	0	0.0
BRAIN	8	0.7	1	0.1	1	0.2
<u>OTHERS</u>	3	0.3	3	0.3	0	0.0
<u>OTHER SYSTEMS</u>	22	2.0	15	1.4	9	1.7

TABLE 1 Number and Rate of Malignant Tumors Among  
Cases and Controls by Major Category

Because of the surprisingly large excess of thyroid and parotid gland tumors, and the ensuing controversy concerning these data, it was decided to repeat and expand the dosimetric studies of the thyroid. The trials were conducted on two of the original x-ray machines. Attempts were made to reconstruct actual treatment conditions by measuring the absorbed dose under different

head positioning, shielding and filtration. The dose to the thyroid ranged from 4.3 rad to 9.9 rad for doses of 350 R per field which confirmed our earlier experiments.

HVL mm Al	THYROID DOSE/350 R	
	Lower Limit	Upper Limit
1.1	4.3	8.4
1.5	5.2	9.9

TABLE 2 Summary of the Results of Repeated Measurements of Radiation Doses Absorbed by the Thyroid

Adjusting for the relative proportion of children receiving the different beam qualities and excluding the two patients who were irradiated twice, the risk estimate of excess thyroid cancer is between 4.8cases/10<sup>6</sup> and 11.1/10<sup>6</sup>.

The finding of 6 excess benign adenomas in the irradiated population of the N.Y. Tinea study (6,7) led us to extend our investigation to include benign neoplasms. To evaluate benign tumors (as well as malignant tumors before the establishment of the Israel Cancer Registry in 1960), we had to check the records of all hospitals in Israel. By examining pathology records, operating room logs, discharge summaries, diagnostic indices and Surgery, ENT and Oncology records, it was possible to obtain the names of all persons in Israel with a thyroid neoplasm diagnosed between 1950-1974. These names were then compared to our study population lists and all patients found on the lists were then classified as case, sibling or population control.

Preliminary data show a statistically significant excess of thyroid malignancies and a non significant increase in adenomas. Table 3 gives a breakdown by diagnosis of these findings.

DIAGNOSIS	IRRADIATED CASES (10,842)	POPULATION CONTROLS (10,842)	SIBLING CONTROLS (5,400)
Carcinoma	19	4	2
Adenoma	5	1	1
Goiter	11	6	5
Cyst	2	1	0
TOTAL	37	12	8

TABLE 3\* Thyroid Disease Among Cases and Controls by Diagnostic Category.

\* These are the data as of January 20, 1977. Final information will be given at the Congress itself.

Further studies were done in order to evaluate delayed effects of brain function, as evidenced by intelligence and educational levels. Though these results are still being analyzed, there is an indication of negative effects.

As an objective measure of brain activity, computerized EEGs were performed on a small sample of the study population. The EEGs were performed, blind, by two experienced technicians and the data analyzed, again blind, by a senior neurologist. At this point, an increase in  $\beta$  wave activity has been found in the male cases. Sub-analyses are still being performed.

#### REFERENCES

- (1) ADAMSON, H.G., A simplified method for x-ray application for the cure of ringworm of the scalp; Kienbock's method, *Lancet* 1 (1909) 1378
- (2) WERNER, A., et. al., Doses to brain, skull and thyroid following x-ray therapy for tinea capitis, *Phys. Med. Biol.* 13 (1968) 247
- (3) SCHULZ, R.J., ALBERT, R.E., Follow up study of patients treated by x-ray epilation for tinea capitis: III. Dose to organs of the head from the x-ray treatment of tinea capitis, *Arch. Environ. Health.* 17 (1968) 935
- (4) LEE, W., YOUMANS, H.D., Doses to the central nervous system of children resulting from x-ray therapy for tinea capitis, DBF 70-4, U.S. Department of Health, Education and Welfare, (1970)
- (5) MODAN, B., et. al., Radiation-induced head and neck tumours, *Lancet* 1 (1974) 277

Supported by USPHS, Bureau of Radiologic Health, Rockville, Md. (No.223-75-6057)

## SURVEY OF CASE REPORTS OF RADIATION-INDUCED CANCER

Y. Yoshizawa and T. Kusama

Department of Radiological Health  
Faculty of Medicine, University of Tokyo, Japan

A careful and wide survey of the cases reported as radiation-induced cancer in some chief organs (the breast, the uterus, the pharynx and larynx, the colon, and the bone) was carried out (1-5).

The number of the cases which were found by this search was 130 in the pharynx and larynx, 548 in the uterus, 10 in the breast, 80 in the colon, and 256 in the bone. Most of these cases had received radiation for the purpose of treatment of non-malignant disease of the organ in question or malignant tumor of another organ, except a case due to occupational radiation exposure (6).

The criteria adopted for the diagnosis of radiation-induced cancer were as follows:

- a. There must have been certain evidence of the non-malignant of the initial condition.
- b. Irradiation must have been given and the cancer that subsequently developed must have arisen in the area included within the radiotherapeutic beam.
- c. A relatively long latent period must have elapsed after irradiation before the clinical appearance of the cancer.
- d. All cancer must have been proved histologically.

The above mentioned criteria are based on the prerequisites which Cahan et al. (7) adopted for radiation bone sarcoma.

Cases of radiation-induced cancer caused by external exposure were chosen as the subjects to this study. Cases of internal exposure, however, did not become the subjects, because of the difficulty in detailed estimation of absorbed radiation dose. Reliable information on the risk-evaluation of external exposure must be very useful for internal exposure.

The distribution and the average of the latent period between the beginning of exposure and the detection of tumor are presented in Table 1. A tendency of long latent period is worth noting from the standpoint of radiation protection and safety.

Table 2 shows histological findings of the cases found by this search.

The case received the lowest irradiation dose was carefully surveyed and estimated the dose. It was impossible to estimate the irradiation dose to the cases in the time when the concept and the measurement of radiation dose were not yet established. Table 3 represents data about the cases of the lowest dose of each organ. The lowest irradiation dose is different from "threshold dose" in the words of radiation biology, nevertheless the data must be useful information in the field of radiation

safety.

Methods of research on human radiation-induced cancer are divided into two following:

- (1) epidemiological survey
- (2) search for clinical case reports.

The results of the second type of research, to which this study belongs, give little numerical information about the dose-effect relation of radiation carcinogenesis, but are practical value to the judgement in the causal dependence of radiation in a clinical case.

#### REFERENCES

- (1) YOSHIZAWA, Y., KUSAMA, T. Search for the lowest irradiation dose from literatures on radiation-induced cancer in pharynx and larynx, Nippon Acta Radiologica 34 12 (1974) 903
- (2) YOSHIZAWA, Y., KUSAMA, T. Search for the lowest irradiation dose from literatures on radiation-induced cancer in uterus, Nippon Acta Radiologica 35 10 (1975) 900
- (3) YOSHIZAWA, Y., KUSAMA, T. Search for the lowest irradiation dose from literatures on radiation-induced breast cancer, Nippon Acta Radiologica 35 12 (1975) 1125
- (4) YOSHIZAWA, Y., KUSAMA, T. Search for the lowest irradiation dose from literatures on radiation-induced cancer in gastrointestinal tract, Nippon Acta Radiologica 36 5 (1976) 433
- (5) YOSHIZAWA, Y., KUSAMA, T. Search for the lowest irradiation dose from literatures on radiation-induced bone tumor, Nippon Acta Radiologica 37 6 (1977) in press
- (6) CARROLL, R.E. et al. Osteogenic sarcoma of phalanx after chronic roentgen-ray irradiation, Cancer 9 (1956) 753
- (7) CAHAN, W.J. Sarcoma arising in irradiation bone, Cancer 1 (1948) 3
- (8) MATER, I. Maligne Entartung Bestrahlter Juveniler Larynx Papillome, Z.Laryngol Rhinal.Otol. 47 (1968) 862
- (9) STACY, L.J. Radium treatment in 600 cases of menorrhagia, Am.J. Roentgenol. 9 (1920) 379
- (10) WOLFE, S.A. et al. Carcinosarcoma of the uterus, Obstet.Gynecol.Surg. 12 (1958) 54
- (11) MAREEL, M. Mammacarcinoma na bestraling beschrijving van twee gevallen, J.Belge. de Radiol. 51 (1968) 348
- (12) RUBIN, P. et al. Incidence of pelvic malignancies following irradiation for benign gynecologic condition, Am.J.Roentgenol. 85 (1961) 503
- (13) ARLEN, M. et al. Radiation-induced sarcoma of bone, Cancer 28 (1917) 1087



Organ	Latent Period (Years)		
	Minimum	- Maximum	Average
Pharynx and Larynx	8	- 15	27.3
Uterus	1	- 40	10.1
Breast	10	- 44	22.7
Colon	1	- 31	13.6
Bone	2	- 42	11.7

Table 1. Latent Period of Radiation-Induced Cancer

Organ	Histopathological Finding
Pharynx and Larynx	Squamous Cell Carcinoma
Uterus	Carcinoma (80%), Sarcoma (12%) Mixed Mesodermal Tumor (8%)
Breast	Duct Cell Carcinoma and Adenocarcinoma
Colon	Adenocarcinoma
Bone	Osteosarcoma (60%), Fibrosarcoma (25%) Chondrosarcoma (7%), Others (8%)

\* Cases of anal cancer were squamous cell carcinoma

Table 2. Histopathological Finding of Radiation-Induced Cancer

Organ	Latent Period (Years)	Dose	Author
Pharynx and Larynx	5	4000 R	Maier(8)
Uterus	3	1400-1600* rads	Stacy(9)
	8	1000-1450** rads	Wolfe(10)
Breast	26	1470 rads	Mareel(11)
Colon	5	460 rads	Rubin(12)
Bone	No Description	800rads***	Arlen(13)
	No Description	1800rads****	Arlen(13)

- \* The case irradiated by intra-uterine radium.
- \*\* The case irradiated by X-ray therapy.
- \*\*\* The case irradiated for the treatment of bone disease.
- \*\*\*\* The case irradiated for treatment of extra-skeletal disease.

Table 3. Data on Lowest Irradiation Dose in Case Reports of Radiation-Induced Cancer

THE EVALUATION OF THE HIGH-ENERGY PROTON  
RADIATION EFFECTS ON THE HUMAN BLOOD-FORMING ORGANS (BFO)  
WITH SELF-SHIELDING TAKEN INTO ACCOUNT

L.N.Smirenyy, V.M.Petrov, A.V.Khortsev

Solar cosmic rays protons and radiation belts protons with the energies of more than 30 MeV are of the greatest hazard for the spaceship crew. These sources of cosmic radiation form the irregular distribution of the depth doses in the body. The depth doses distribution depends on the spectrum of the protons. The best description of the spectra now is given in the form of

$$N(P) = N_0 e^{-P/P_0} \quad (1)$$

where  $P_0$  is a characteristic rigidity (MV). According to the estimate the dose at the depth of 5 cm of tissue is less as compared with the skin dose in the factor of 4-14 for the solar events with  $P_0$  of 195 MV and 30 MV respectively. These depth dose distributions should be taken into consideration while estimating the irradiation doses on various human organs. The most difficult thing is to estimate the radiation effect on the blood-forming organs (BFO) as they are in various places of a human body. BFO have the highest radiosensitivity. One of the widely spread diseases is a BFO-form of the radiation sickness. So the BFO irradiation is the most important factor in the estimation of radiation hazard for a man.

The affection value of the BFO is determined by the irradiation dose. In case of dogs (3) this dependence is shown in fig. 1. To estimate the radiation hazard under the above-mentioned conditions it is necessary to establish the physical index describing the BFO affection in the best way. According to the modern data an unaffected part of the BFO can help to reconstruct the functioning of the BFO system. Having assumed that the radiation affection doesn't depend on the position of the BFO cells and is determined only by their quantity, it is possible to estimate the BFO affection value with the help of an average number of the dead cells per unit of volume (5):

$$L = \frac{1}{V} \sum_{i=1}^n f(D_i) \Delta V_i \quad (2)$$

where  $D_i$  - is the dose in the elementary volume  $\Delta V_i$ , and  $n$  - is the number of these volumes, finding place in the total BFO volume.

Let's assume that the affection value of the human BFO is similar to the one shown in fig.1. Then this dependence can be described with the help of the linear function  $f(D) = \kappa D$  in the range of up to 200 rads with an error of less than 20%. Based on this law we may rewrite equation (2):

$$L = \frac{\kappa}{V} \sum_{i=1}^n D_i \Delta V_i \quad (3)$$

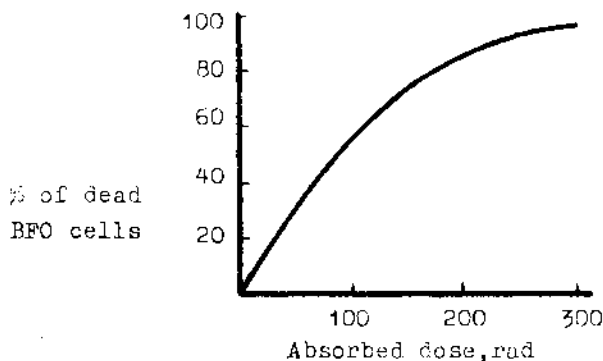

Fig. 1 The dependence between the BFO affection and an irradiation dose for dogs

Thus, the irradiation effect may be characterized in this dose range with the help of the average dose for the total BFO.

$$D_{BFO} = \frac{1}{V} \sum_{i=1}^n D_i dV_i \quad (4)$$

Let's note that the dose range is of the greatest interest as it includes the doses used at the reglamentation of the cosmonauts' irradiation (1).

The strongest hazard for the cosmonauts takes place when they work in the space suits or in the orbital moduls with the shield thickness of less than 1-2 g.cm<sup>-2</sup>. In this case one can assume that the radiation is isotropic. BFO doses were carried out for these conditions. It was assumed that the estimations of protons spectra have characteristic rigidity in the range of 80-195 MV.

Using the so called "straightahead model" (6) we may write the average dose on the BFO in the following way:

$$D_{BFO} = \frac{1}{4\pi V} \sum_{i=1}^n \Delta V_i \sum_{j=1}^m D(h_i) \Delta \omega_{ij} \quad (5)$$

where  $\Delta \omega_{ij}$  is a solid angle in which the tissue thickness, shielding the elementary volume  $\Delta V$  is  $h_i$ .

If we consider the value of  $\Delta V$  to be constant then in this case  $\Delta V/V$  is equal to  $1/n$ . Assuming that the tissue thickness accounted into consideration differs in the values in proportion to  $\Delta h$ , we may rewrite equation 5 in the following way:

$$D_{BFO} = \frac{1}{4\pi n} \sum_{i=1}^m D(h_i) \sum_{j=1}^n d\omega_{ij} \quad (6)$$

The value of  $\Delta \omega_i = \frac{1}{h_i} \sum_{j=1}^n d\omega_{ij}$  is an equivalent solid angle, corresponding to the tissue thickness of  $h_i$ . In these terms the equation (6) may be rewritten:

$$D_{BFO} = \frac{1}{4\pi n} \sum_{i=1}^m D(h_i) \Delta \omega_i \quad (7)$$

Thus, for evaluating BFO doses it is necessary to find the dependence between  $\Delta\omega^*$  and the tissue thickness. For this purpose the shielding of 330 points in which BFO were placed, was calculated with the help of method (6). The dependence of  $\Delta\omega^*$  ( $h_i$ ) mean with respect to the whole body is shown in fig.2

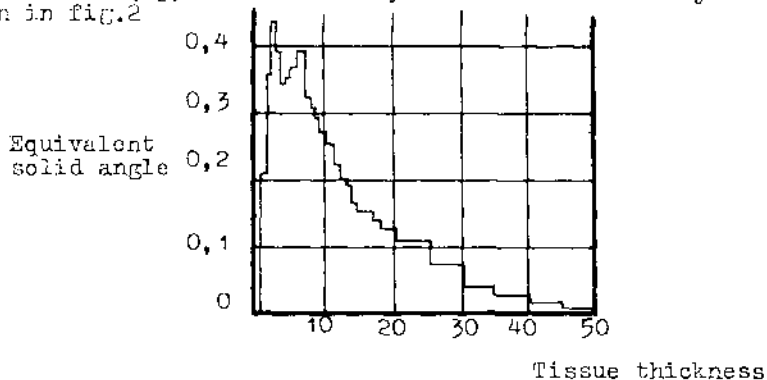

Fig.2 The dependence between the equivalent solid angle and the tissue thickness

The analysis of these data shows that the tissue thickness of less than  $10 \text{ g}\cdot\text{cm}^{-2}$  is of the major importance while evaluating the average dose on the BFO. The solid angle corresponding to these values of the shielding thickness is more than 50% of the total solid angle. In this case the average BFO dose is formed by the primary radiation.

The evaluation of the dose part formed by the secondary radiation gives the value of 10-15% from the total dose.

BFO doses calculated in this way in case of solar cosmic rays, are given in the following table

Shielding: thickness: $\text{g}\cdot\text{cm}^{-2}$		$P_0$ MV			
		80	100	120	195
0	$D_{\text{BFO}}$ , rad	41	45	47	52
	$Z_{\text{ef}}$ , cm	4,5	5,0	5,5	7,0
0,5	$D_{\text{BFO}}$ , rad	29	34	38	44
	$Z_{\text{ef}}$ , cm	5,0	5,5	6,5	7,5
2,0	$D_{\text{BFO}}$ , rad	20	21	24	33
	$Z_{\text{ef}}$ , cm	5,5	6,5	7,5	8,5

The dose values  $D_{\text{BFO}}$  and the effective BFO shielding  $Z_{\text{ef}}$  in case of the solar cosmic rays with  $P_0 = 80-195 \text{ MV}$  and  $N_0 = 10^9 \text{ cm}^{-2}$

The values of the effective BFO shielding were evaluated on the basis of the attenuation curves of the dose, when  $A_0 = 80-195$  MV and the shielding thickness is 0;0,5 and 2 g.cm<sup>-2</sup>. eff values are given with the accuracy  $\pm 0,3$  cm.

The above-mentioned data show that the effective BFO shielding depends on the characteristic rigidity of spectrum.

Thus, radiation hazard evaluations may be incorrect as they are based on dose values only at the depth of 5 cm of tissue.

This approach to radiation hazard evaluation may be made more accurate in case of obtaining new data concerning the dependence between the BFO affection and an irradiation dose for a man.

#### REFERENCES

- (1) Biological effect of the high-energy protons, Atomizdat, Moscow 1967
- (2) Guskova A.K., Baisogolov G.D., Radiation sickness of a man, Meditsina, Moscow 1971
- (3) Abramova G.M. e.a., The Forecast of the biological effects at the irregular irradiation of dogs by high energy protons, in alm. "Biological effects of irregular radiation influence", Atomizdat, M., 1974
- (4) Jammet H.P. e.a., in "Radiation Protection", Proceedings of the First International Congress held in Rome, September 1966, part 2, ed. by W.S. Snyder, Pergamon Press, London-N.Y.-Paris, p. 1249
- (5) Keirim-Markus I.B., Dosimetric index of the acute radiation effects, Medical Radiology, 17, number 7, 1972
- (6) Dudkin V.E. e.a., Investigation of the shielding boundaries influence on the dose field forming in case of charged particles, Moscow, MEFnI-1964
- (7) Smirenniy L.N., Litvinova E.G., Khortsev A.V., Study of Spatial distribution of tissue doses with the aid of a phantom-mannequin ICI Intern. Congress ICRPA Washington 1973.

## EXEMPLES THEORIQUES ET EXPERIMENTAUX D'EFFETS NON MONOTONES

J. DELFORGE

Commissariat à l'Energie Atomique  
 Centre d'Etudes Nucléaires de Saclay  
 Département de Biologie (GEERSM)

## 1. INTRODUCTION

En 1919, P. Davey publia un article intitulé "Prolongation of life of *Tribolium confusum* apparently due to small doses of X-Rays" (1). La prudence qui caractérise cet article soulignée par le "apparently" du titre, est une réaction naturelle devant la nouveauté et l'irrationalité apparente du résultat. Durant encore de nombreuses années, lorsqu'un expérimentateur observait un effet analogue, il l'attribuait à un artefact, ou ne le publiait que très timidement. Or, le développement récent des études effectuées aux faibles débits de dose a permis de confirmer l'apparition de nombreux phénomènes inattendus, souvent regroupés sous le terme de "phénomènes paradoxaux" car apparemment contradictoires avec les théories en vigueur sur les effets des rayonnements, élaborées pour la plupart pour des débits de dose importants. Cependant, le caractère paradoxal n'étant bien entendu qu'une apparence, il nous a semblé préférable de regrouper ces phénomènes sous le terme "d'effets non monotones", qui décrit mieux leur originalité.

Après avoir défini de manière précise au § II, quelques exemples importants d'effets non monotones, nous indiquerons pour chacun d'eux les principaux résultats connus et les conséquences possibles de ceux-ci sur les problèmes de radioprotection. Sans chercher, bien entendu, à donner une explication précise de l'apparition de ces phénomènes, nous montrerons au § III qu'ils peuvent s'interpréter à partir d'hypothèses très simples. Nous soulignerons enfin, dans le dernier paragraphe, que leur apparition est un nouvel argument très important en faveur de l'abandon de la dose comme variable principale de référence, celle-ci devant être remplacée par la variable "temps" et le paramètre "débit de dose" comme le préconise P. Delattre (2,3).

## 2. EXEMPLES EXPERIMENTAUX D'EFFETS NON MONOTONES

Les phénomènes rencontrés aux faibles débits de doses sont très variés. Nous en décrirons ici trois exemples typiques, selon les grandeurs retenues comme variables et paramètres de référence.

## a) Effets non monotones en fonction du débit de dose, à dose constante

Il a été observé dans de nombreuses études expérimentales que l'effet de l'irradiation pour une dose donnée augmente avec le débit de dose utilisé pour administrer cette dose. On explique généralement cet effet de débit de dose par l'existence de phénomènes spontanés de restauration qui ont d'autant plus d'influence sur l'effet observé que le temps d'irradiation est important, c'est-à-dire que le débit de dose est faible.

Cependant, plusieurs expériences récentes (4,7) effectuées à des débits de dose faibles ont montré que, pour une dose donnée, la courbe donnant l'effet en fonc-

tion du débit de dose utilisé, est non monotone, c'est-à-dire présente un minimum (figure 1).

Une augmentation du débit de dose conduit donc soit à une augmentation, soit à une diminution de l'effet, suivant la valeur du débit de dose.

Ces résultats peuvent donc être en contradiction avec l'hypothèse souvent admise, selon laquelle les mesures effectuées à des débits de dose importants donnent une majoration des effets observables pour cette même dose, mais délivrée à des débits de dose plus faibles.

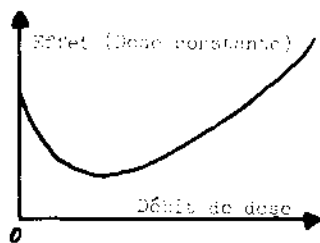

Figure 1

Remarque : Certains des résultats expérimentaux (5,7) ont seulement permis de mettre en évidence la décroissance initiale de l'effet avec l'augmentation du débit de dose. Bien qu'il soit probable que, dans la plupart des cas, la courbe passe par un minimum et devient croissante à partir d'un certain débit de dose, on ne peut pas exclure a priori l'éventualité d'une courbe constamment décroissante (figure 2).

Un tel phénomène peut, comme nous le verrons au § III, se rencontrer dans des modèles théoriques très simples.

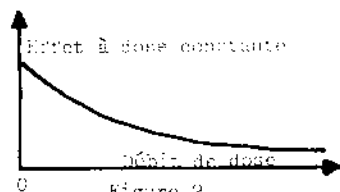

Figure 2

#### b) Effets non monotones dans les expériences de fractionnement de dose

Les expériences de fractionnement de dose ont généralement pour but de mettre en évidence des phénomènes de restauration. Le fait de n'envisager que ce type de phénomènes spontanés a conduit les expérimentateurs, en accord avec de nombreux résultats expérimentaux, à considérer que l'effet ne peut qu'être diminué par un fractionnement de dose et par l'augmentation du temps  $\tau$  séparant les irradiations successives. Cependant, cette affirmation a été contredite par plusieurs résultats expérimentaux récents (8,10) où l'on a observé un effet non monotone en fonction du temps  $\tau$  (figure 3). Dans ce cas, une irradiation fractionnée avec un intervalle de temps suffisamment faible entre irradiations successives conduit à une augmentation de l'effet par rapport à une irradiation continue, alors qu'un temps  $\tau$  suffisamment élevé conduit par contre à une diminution de l'effet. L'existence d'un tel phénomène est un nouvel argument montrant que la dose cumulée n'est pas en général un critère suffisant, et qu'il est nécessaire de considérer la distribution chronologique de l'irradiation.

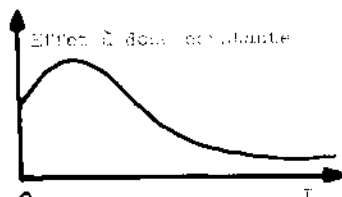

Figure 3

irradiation continue ( $\tau=0$ )



c) Effet non monotone en fonction du débit de dose à durée d'irradiation constante.

L'étude de la variation de l'effet en fonction du débit de dose, d'une irradiation effectuée pendant un temps T donné, est surtout liée au problème d'environnement : quelles seraient les conséquences d'une augmentation de l'intensité de l'irradiation ambiante ? Les expériences effectuées pour répondre à cette question sont contradictoires. Si beaucoup d'expériences montrent l'augmentation attendue de l'effet avec le débit de dose, d'autres effectuées à très faible débit de dose montrent par contre l'existence de phénomènes non monotones (11,15) (cf. d'autres références dans (16)). Dans un premier temps, l'augmentation du débit de dose (et donc de la dose cumulée) conduit paradoxalement à une diminution de l'effet. Dans la plupart des cas, les auteurs montrent également que la courbe présente un minimum puis devient croissante avec le débit de dose (figure 4).

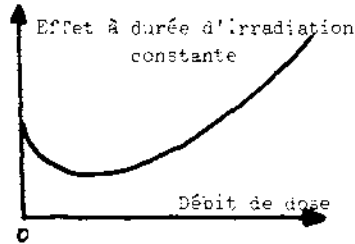

Figure 4

### 3. POSSIBILITES D'INTERPRETATION DES PHENOMENES NON MONOTONES

Loin d'être rarissimes, les effets non monotones peuvent en réalité se rencontrer dans de nombreux systèmes simples. Les trois ensembles que nous allons donner n'ont bien entendu pas la prétention d'expliquer l'apparition de ces phénomènes mais de montrer que leur interprétation théorique ne nécessite pas, comme on pourrait le croire, l'introduction de phénomènes élémentaires complexes et difficilement explicables.

- Exemple 1 : Des effets non monotones en fonction du débit de dose, à dose constante, peuvent se rencontrer lorsque l'effet global observé est la somme de plusieurs effets élémentaires restaurables (par exemple dans les courbes de survie où la mort peut être due à plusieurs causes différentes).

- Exemple 2 : L'introduction dans le système d'une cinétique propre, non limitée aux seuls phénomènes de restauration (par exemple l'introduction d'un phénomène de multiplication dû à un cycle cellulaire), conduit souvent à des effets non monotones en fonction du débit de dose, soit à durée d'irradiation constante, soit à dose constante, soit quelquefois aux deux à la fois (cf. exemple dans (17)).

- Exemple 3 : L'introduction dans le système d'un phénomène de réserve (pool) conduit souvent à de nombreux effets inattendus. Par exemple, un modèle très simple décrit dans (18) conduit simultanément à un seuil sur la courbe dose-effet, à un effet monotone décroissant en fonction du débit de dose à dose constante (semblable à celui de la figure 2), et à un effet non monotone dans les expériences de fractionnement de dose (semblable à celui de la figure 3).

### 4. VERS UNE ETUDE DE LA CINETIQUE DES EFFETS DES RAYONNEMENTS

Il est évident que ce qui peut surprendre le plus dans l'étude des phénomènes non monotones, c'est que la dose ne joue plus le rôle privilégié de variable de référence qu'on lui attribue généralement en radioprotection. Certes, les radiobiologistes et les spécialistes de la radioprotection ont depuis longtemps

reconnu, par exemple, que le débit de dose joue un certain rôle dans la réponse de nombreux systèmes. Mais ils ont estimé qu'il suffirait de considérer le débit de dose comme un simple facteur correctif, donc non inclus dans le corps conceptuel de la théorie, ce qui est évidemment insuffisant pour donner à celle-ci un caractère prévisionnel suffisant.

Il y a plusieurs années que P. Delattre, à partir d'une étude théorique sur les systèmes de transformation, a souligné la nécessité d'abandonner la notion de dose au profit de la variable temps et du paramètre débit de dose (2,3). Cet auteur considère que le moment est venu de passer de la "dosimétrie des effets des rayonnements" à la "cinétique des effets des rayonnements", en particulier pour tout ce qui concerne les effets des faibles intensités. En effet, il est certain que dans ce domaine où les réactions spontanées des organismes irradiés sont en compétition directe et immédiate avec les processus élémentaires provoqués par le rayonnement, la seule dose absorbée ne peut pas, dans la plupart des cas, permettre de rendre compte de la totalité des effets observés.

On peut espérer que les phénomènes non monotones, aujourd'hui de mieux en mieux connus, inciteront finalement les spécialistes de la Dosimétrie à faire évoluer leur discipline vers les études de cinétique fine seules capables de rendre compte de la complexité des effets observés.

#### REFERENCES

- (1) DAVEY P. J. *of. Experimental Zoölogy*, 28, 3 (1919), 447
  - (2) DELATTRE P. *General Systems Yearbook*, 18, (1973), 27
  - (3) DELATTRE P. *Symposium IAEA-SM-202/503*, (1976), 275
  - (4) LYON M.F. et al. *Nature New Biology*, 238 (1972)
  - (5) NORRIS W.F. *5th Congress of Radiation Research*, (1974)
  - (6) BATCHELOR A.L. *Mut. Res.*, 4 (1976), 229
  - (7) LUZ A. *Symposium IAEA-SM-202/406*, (1976)
  - (8) MOUSSEAU J. et al. *C.R. Acad. Sc. Paris*, 283, Série D (1976), 579
  - (9) DEEN D.F. *Symposium IAEA-SM-202/103* (1976)
  - (10) RUSSELL W.L. *Genetics*, 48 (1962), 1724
  - (11) PLANEL H. et al. *C.R. Acad. Sc. Paris*, 262, Série D (1966), 2767
  - (12) ZIRKLE R.E. (editor) *Biological effects of external X and Gamma Radiation* chap. III, Mc Graw Hill, New-York (1954)
  - (13) RUST J.M. *Radiation and Ageing*, Taylor and Francis LTD, London (1966)
  - (14) NIEMANN E.G. et al. *Symposium IAEA-SM-202/206* (1976)
  - (15) DUCOFF M.S. *Symposium IAEA-SM-202/212* (1976)
  - (16) DELPA M., VIGNES S. *Symposium IAEA-SM-184/21* (1974)
  - (17) DELFORGE J. Note DB/GEERSM n° 55, CEN-Saclay (1975)
  - (18) DELFORGE J. Note DB/GEERSM n° 72, CEN-Saclay (1976)
- (les papiers correspondant aux références (17) et (18) peuvent être fournis sur demande à l'auteur)

L'OPTIMISATION DE LA RADIOPROTECTION DANS LES MINES D'URANIUM

F. FACNANI , P. MAITRE , T. MESLIN , P. PAGÈS

Commissariat à l'Energie Atomique - DPr/LSEES -B.P. n°6  
92260- Fontenay-aux-Roses- France

I. PRESENTATION DU PROBLEME

1.1. Délimitation du problème

L'analyse des facteurs conditionnant l'exposition des mineurs fait apparaître trois sortes de risques liés à la radioactivité et s'ajoutant aux dangers inhérents au travail minier (fig. 1) :

- l'irradiation externe,
- la contamination interne par les poussières dites à vie longue,
- la contamination interne par le radon et ses descendants.

C'est parce qu'il représente environ les deux tiers du risque radiologique total, qu'il peut faire l'objet de mesures efficaces et qu'il possède une spécificité permettant de le traiter séparément, que nous nous sommes intéressés en priorité au risque présenté par le radon et ses descendants.

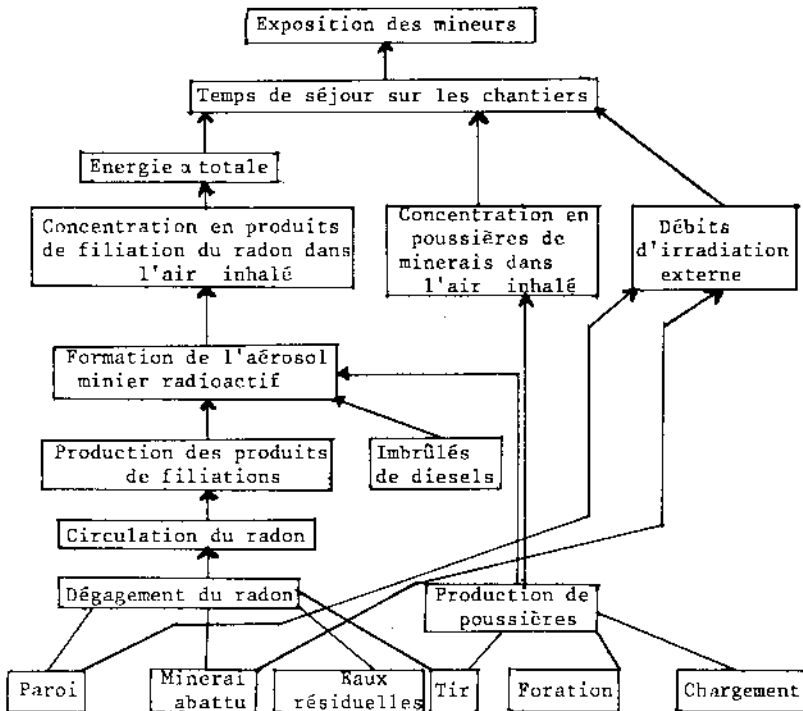

FIGURE 1 : Eléments qui interviennent dans la définition de l'exposition individuelle aux risques.

## 1.2. Indicateurs de risque

L'évaluation du risque occasionné par le radon se fait actuellement en pratique à l'aide de l'indicateur suivant : la concentration de radon (exprimée en Ci/l). On la mesure avec une précision raisonnable sur des échantillons d'air prélevés sur place. Toutefois, la plupart des épidémiologistes s'accordent désormais à considérer qu'un indicateur fondé sur la mesure de l'énergie  $\alpha$  libérée dans l'atmosphère de la mine possède une meilleure valeur prédictive quant à l'apparition du cancer du poumon. Mais la mesure de l'énergie  $\alpha$  se révèle à la fois très difficile et très imprécise ; la modélisation constitue un moyen intéressant dans une telle situation pour suppléer à l'insuffisance des données expérimentales (fig. 2).

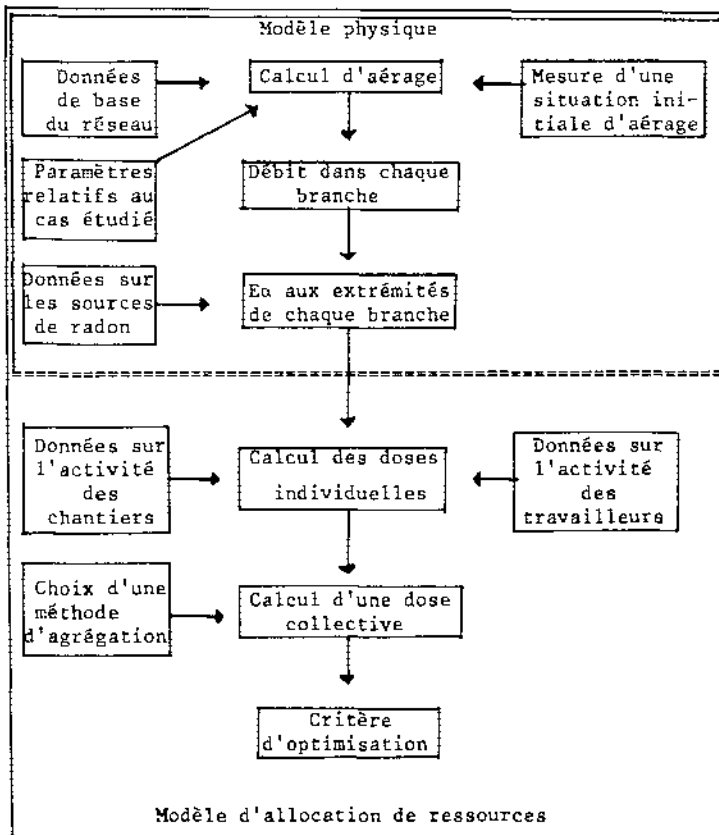

Figure 2 - Organigramme fonctionnel du modèle

### 1.3. Les modes d'agrégation et les stratégies

L'expérience montre que l'"aéragé" est la variable d'action essentielle dans la lutte contre le radon. L'optimisation de l'"aéragé" peut se faire en fonction de différents critères.

L'utilisation de l'un ou de l'autre des indicateurs ne donne pas, à priori, les mêmes résultats. D'autre part, suivant la formule d'agrégation des doses individuelles retenue, les résultats de l'optimisation peuvent être différents. Plusieurs politiques sont possibles sous la contrainte de la dose maximale admissible et indépendamment des considérations ayant trait aux relations dose-effet, par exemple :

- diminution des écarts entre les risques individuels,
- diminution du risque maximum,
- diminution du risque moyen.

### 1.4. Importance des relations dose-effet

Dans l'ignorance où nous nous trouvons des relations dose-effet aux faibles doses, il est clair que toute hypothèse sur ces relations entraîne des conséquences sur le choix des politiques de protection. Par exemple, si l'on fait l'hypothèse de l'existence d'un seuil, on est amené à préférer une politique de protection telle que la valeur maximum de la distribution de doses reste inférieure à cette limite ; d'autres hypothèses auraient d'autres conséquences sur les choix.

## II. LES RESULTATS PROPRES A LA MINE ETUDIEE

### 2.1. Comparaison des deux indicateurs de risque

Essentiellement, trois résultats se dégagent.

2.1.1. Une plus grande sensibilité de l'indicateur "Énergie  $\alpha$ " ( $E\alpha$ ) : la variation relative de l'énergie  $\alpha$  est toujours supérieure à la variation relative de la concentration de radon ( $Rn$ ) sur une branche. Le rapport de la concentration de radon à l'énergie  $\alpha$  :  $\frac{E\alpha}{Rn}$  s'accroît donc lorsque l'on se rapproche du jour (fig. 3)

2.1.2. L'âge moyen du radon, de l'ordre de 20 minutes, montre que l'on est plus proche de l'équilibre 1/4 que 1/2, hypothèse prudente admise dans l'ensemble des mines françaises. (\*)

2.1.3. Les allures générales des histogrammes (figure N° 4) sont identiques pour les deux indicateurs. L'hypothèse d'équilibre 1/4 pour l'estimation des doses en énergie  $\alpha$  à partir de la concentration de radon se révèle plus proche de l'estimation directe en énergie  $\alpha$  par le modèle que l'hypothèse 1/2.

### 2.1. Comparaison entre différents moyens de protection

On a réalisé sur le modèle une série limitée d'"expérimentations" fondées uniquement sur le déplacement des ventilateurs et l'implantation des barreaux appropriés.

---

(\*) Ces résultats ne sont valables en toute rigueur que pour la mine étudiée et ne peuvent donc être généralisés.

2.2.1. L'allure bimodale des histogrammes qui se retrouve d'une distribution à l'autre semble s'expliquer par l'existence de deux ensembles de postes de travail contaminés à des niveaux différents, associés à l'hypothèse pessimiste d'une certaine permanence de la main-d'oeuvre à ces postes.

2.2.2. Aucune des solutions envisagées n'améliore de façon déterminante la solution de référence.

2.2.3. La comparaison des moyens de protection est possible dès que l'on a adopté une façon d'agrèger les distributions de doses. On trouve ici que les classements des solutions envisagées restent sensiblement les mêmes quel que soit l'indicateur de risque ou le critère d'agrégation : on est dans tous les cas conduit au même choix de la solution optimum, mais il n'y a pas de raison de penser que ce résultat se généralise à tous les types de mine envisageables.

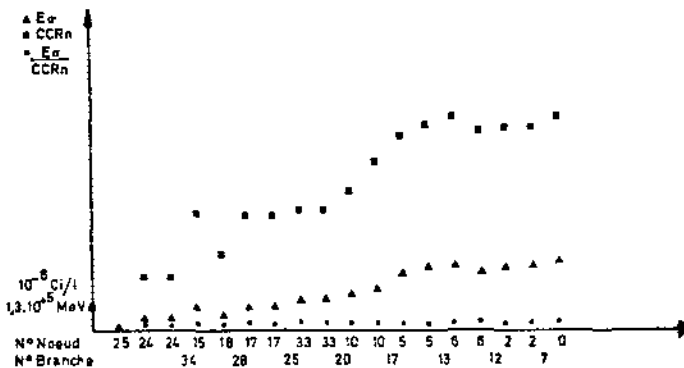
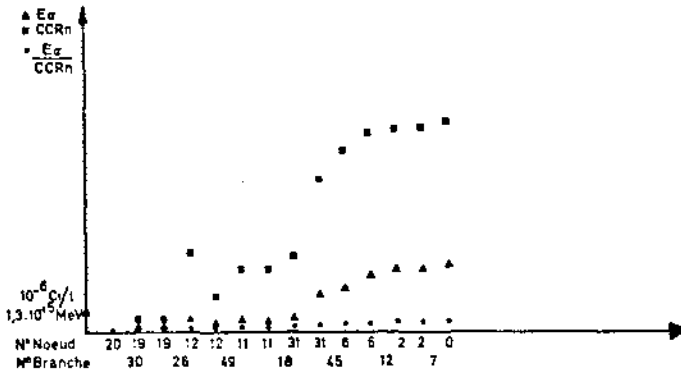

FIGURE 3 : Evolution comparées de la concentration de Radon et de l'énergie totale le long d'un chemin.

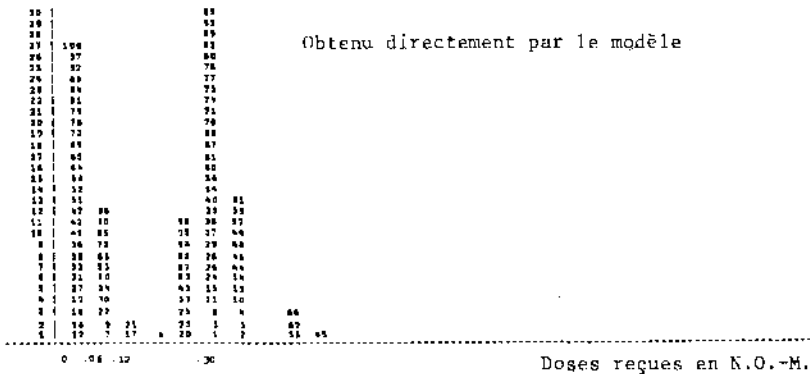
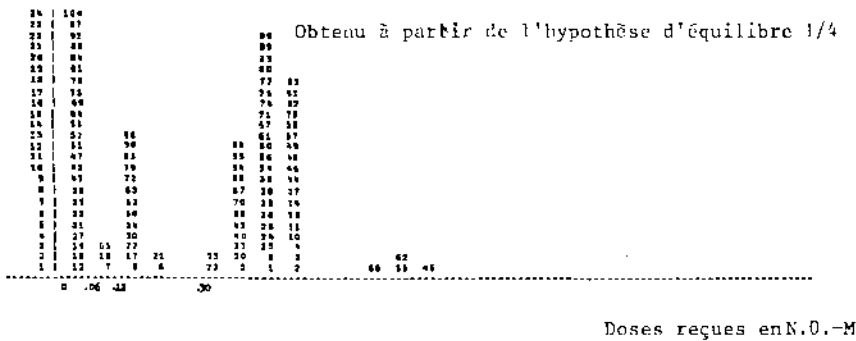
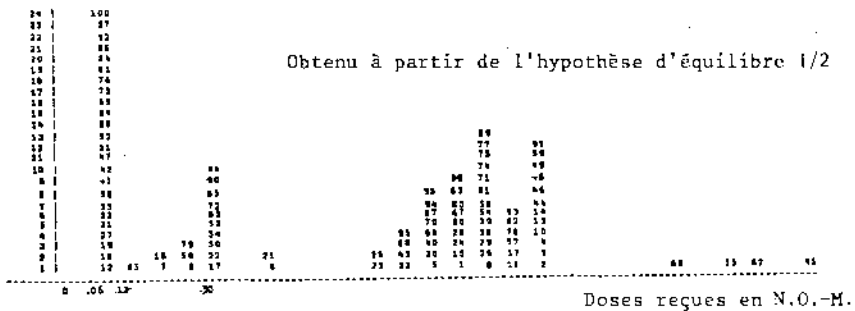

FIGURE 4 : Histogrammes des doses reçues par la population - Test en N.O.-M.

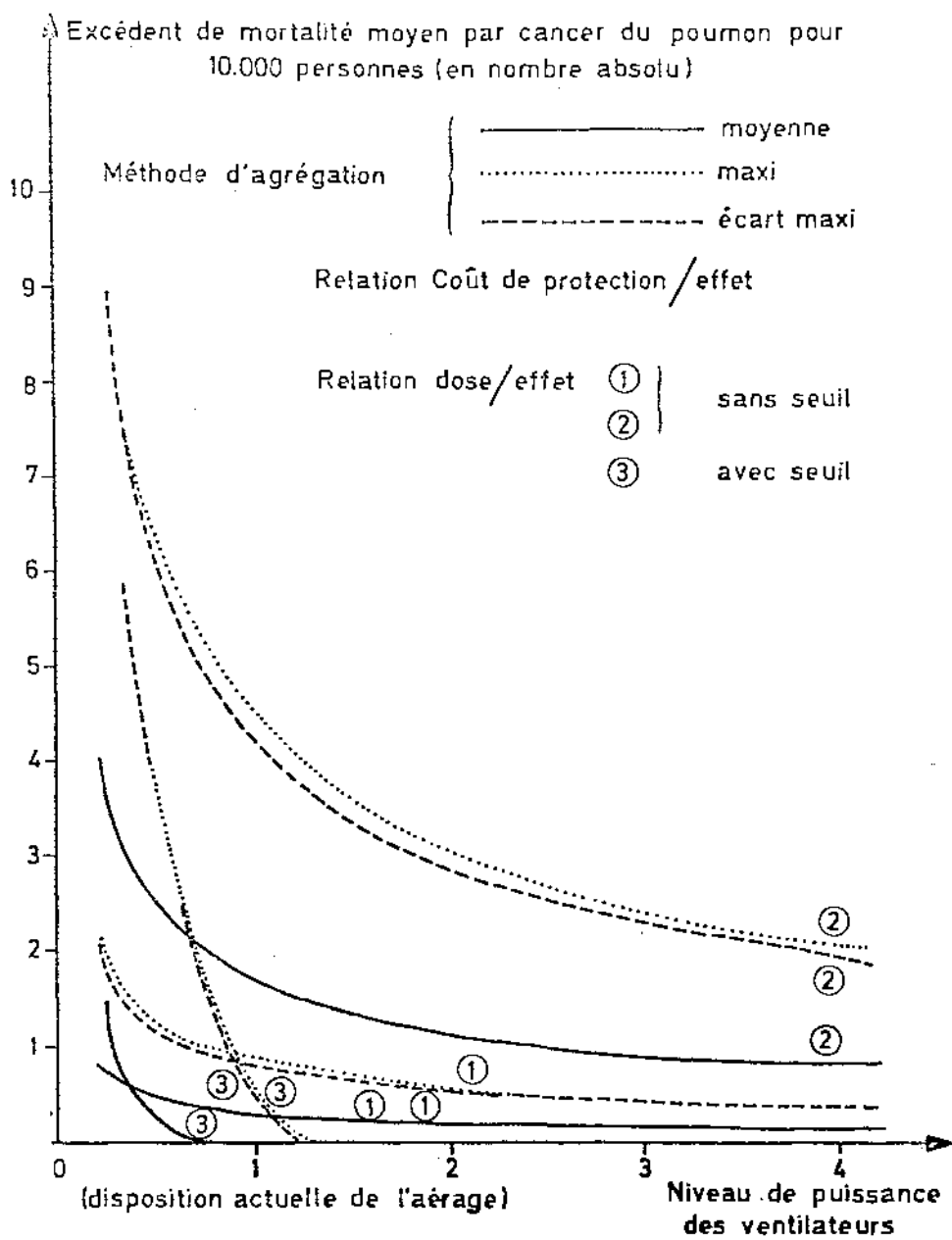

FIGURE 5



### III. PRISE EN CONSIDERATION DES RELATIONS DOSE-EFFET

En toute rigueur, si l'on considère que le véritable indicateur de risque individuel en matière de radioprotection doit être fondé sur la mesure d'une dose cumulée, on est conduit à intégrer le critère précédent, qui correspond à l'exposition instantanée du travailleur (c'est-à-dire en fait à un débit de dose), sur la durée T de cette exposition et à formuler des hypothèses sur les relations qui permettent de passer aux effets associés à ces doses.

Le problème de l'optimisation de la radioprotection pourra alors s'exprimer comme la minimisation sur un ensemble de politiques admissibles, d'un critère (au moins) agrégeant la distribution des effets (c'est-à-dire des risques individuels). Les politiques à prendre en compte sont celles qui respectent les contraintes techniques et socio-économiques du moment.

Les questions d'ordre méthodologique qui se posent à ce niveau sont liées à l'influence sur le résultat du procédé d'agrégation d'une part, de la forme de la relation dose-effet d'autre part : par exemple, à quelles conditions peut-on raisonner, dans un calcul d'optimisation de la radioprotection, aussi bien sur les doses que sur les effets? Par ailleurs, comment prendre en compte au niveau des résultats de l'optimisation les larges incertitudes qui demeurent malgré les nombreuses recherches biomédicales concernant les effets des rayonnements aux faibles doses? Il s'agit en particulier de l'existence d'un seuil en-deça duquel une exposition serait sans effet sur l'organisme.

Quelques propriétés simples des résultats de l'optimisation selon le critère d'agrégation et la loi dose-effet se démontrent facilement :

- i) les résultats sont les mêmes qu'on raisonne au niveau des effets ou des doses, si le critère utilisé consiste à minimiser le risque sur l'individu le plus exposé.
- ii) il y a également équivalence -ceci quel que soit le critère- lorsque la relation dose-effet est linéaire (sans seuil). C'est cette propriété -signalée au paragraphe 15 de la C.I.P.R. 22- qui permet en fait de raisonner le plus souvent sur les doses dans un calcul d'optimisation (cf. ici § II, Résultats).
- iii) dès que la relation dose-effet n'est plus linéaire, on peut avoir des distributions de doses pour lesquelles un critère donné induit un ordre de préférence différent de celui obtenu lorsqu'on passe à l'effet.

Ces propriétés sont illustrées sur le diagramme suivant (figure 5) propre à une étude coût-efficacité. Ici, à titre d'exemple, on a pris comme coût de la protection le coût entraîné par une augmentation de la puissance des ventilateurs :

- trois relations dose-effet compatibles avec les résultats expérimentaux :
- deux relations sans seuil représentant l'enveloppe des hypothèses les plus couramment admises et une relation avec seuil à 50 NO-M.
- trois critères d'agrégation (cf. ci-dessus pour les doses) :
  - . la moyenne,
  - . le maximum,
  - . l'écart maximum.

L'utilisation de ces relations a nécessité par ailleurs une nouvelle hypothèse : on a construit un échantillon de doses cumulées (pendant 25 ans) en supposant la répartition des doses marginales (débits de doses) calculées par le modèle constante dans le temps. Il est certain qu'il y a là surestimation du risque puisqu'il n'est pas tenu compte des phénomènes de compensation.

La combinaison de critères à laquelle on arrive est assez complexe : neuf cas possibles.

Le coût de protection est exprimé ici, à titre d'exemple, en terme de niveau de puissance des ventilateurs pour un circuit d'"aéragé" supposé fixé à son optimum. On obtient ainsi un ensemble de courbes (figure 5) dont la variabilité s'explique par la diversité des hypothèses envisageables. Les deux courbes extrêmes délimitent une aire à l'intérieur de laquelle tout choix d'investissement se révèle raisonnable et trouve une justification dans le cadre des contraintes socio-économiques propres au problème étudié. Si on songe par ailleurs aux difficultés qui entravent l'évaluation complète et pertinente du détriment (\*), on voit avec quelle prudence il faudrait aborder les méthodes d'optimisation de la protection qui auraient pour ambition l'évaluation monétaire complète des coûts et des avantages.

---

(\*) Cf. des travaux entrepris par ailleurs sur cette question spécifique :

- G. BRESSON, F. FAGNANI, G. MORLAT - Méthodes coût-avantages dans le domaine de la radioprotection (aspects méthodologiques).  
In : Population dose evaluation and standards for man and his environment, Portoroz, May 20-24, Vienne, AIEA, 1974, p. 195-216.
- E. LEVY, G. DUMENIL, M. BUNGENER, F. FAGNANI - Evaluer le coût de la maladie, Dunod, Paris, 1976.

L'AERAGE ET LES CARACTERISTIQUES DE L'ATMOSPHERE  
D'UNE MINE D'URANIUM LABORATOIRE

Ph. DUPOURT, G. MADELAINE, P. ZETTWOOG

Commissariat à l'Energie Atomique

Département de Protection  
Section Technique d'Etudes de Pollution  
dans l'Atmosphère et dans les Mines

A. RENOUX, J.Y. BARZIC

Faulté des Sciences

U.E.R. Sciences de Brest

## 1. INTRODUCTION

Dans la mine d'uranium laboratoire du Commissariat à l'Energie Atomique, on évalue l'influence des différents paramètres d'aéragé sur la concentration et le débit du radon.

Cette mine étant hors exploitation, on détermine les spectres granulométriques des aérosols radioactifs et non radioactifs, la fraction de radioactivité existant sous forme ultrafine (fraction libre) et la proportion du  $^{218}\text{Po}$  (RaA) fixé sur les particules ionisées.

## 2. INFLUENCE DE L'AERAGE SUR LA RADIOACTIVITE DE L'AIR EN MINE

L'aéragé de la mine laboratoire étant entièrement contrôlé, on mesure l'influence de la pression par rapport à l'atmosphère, sur le débit du radon.

Nos résultats, illustrés, (fig. 1), montrent que la surpression diminue le débit du radon de manière notable. Ce fait peut être étendu à tout quartier d'une mine exploitée.

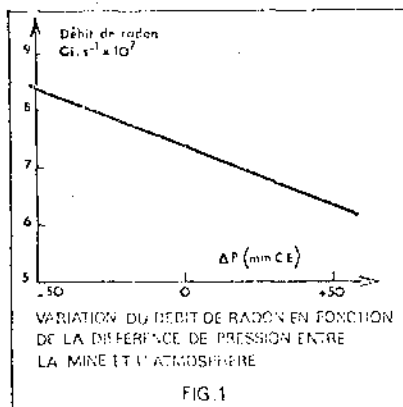

### 3. SPECTRE DES AEROSOLS DANS LES MINES D'URANIUM

Par deux méthodes différentes (1) (2), on détermine la répartition granulométrique des aérosols dans les mines d'uranium. La fig. 2 représente les spectres granulométriques des noyaux de condensation radioactifs et non radioactifs dans la mine laboratoire hors activité (1).

Les courbes de la fig. 3 représentent les pourcentages cumulés de la radioactivité  $\alpha$  en fonction du rayon des particules, ceci pour différentes opérations d'exploitation et pour l'aérosol de la mine laboratoire.

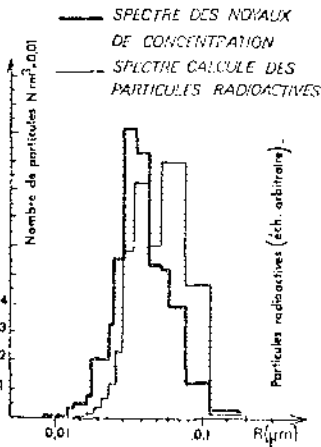

FIG. 2

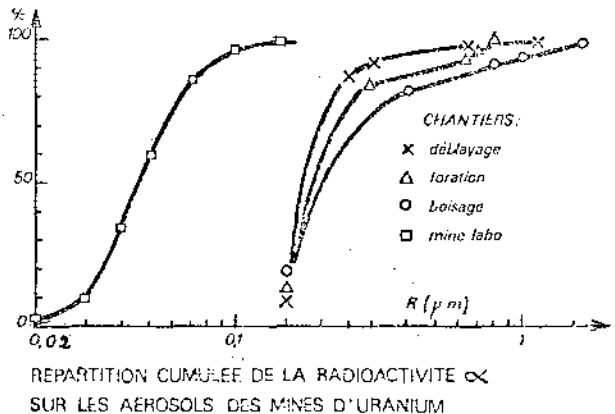

FIG. 3

### 4. FRACTION LIBRE

Nous mesurons les fractions libres  $^{218}\text{Po} - \text{RaA}$  ( $f_A$ ),  $^{214}\text{Pb} - \text{RaB}$  ( $f_B$ ) et  $^{214}\text{Bi} - \text{RaC}$  ( $f_C$ ) présentes dans l'air de la mine laboratoire, en utilisant différentes techniques faisant appel à la diffusion des aérosols (3).

Nous définissons la fraction libre  $f_i$  du Ra (i) de la façon suivante :

C'est le rapport de la concentration des particules ultrafines porteuses de Ra (i) à la concentration totale des aérosols porteurs de Ra (i).

Nos résultats moyens sont les suivants :

$$f_A = 0,30, f_B = 0,16, f_C = 0,15.$$

On a sélectionné pour les mesures en chantier, l'appareil de prélèvement à grille de tamis métallique décrit par THOMAS et HINCHLIFFE (4) en raison de sa facilité d'emploi et de la quantité importante de particules qu'il retient et que l'on peut donc mesurer avec le minimum d'erreurs statistiques.

On vérifie (1) que les théories classiques de la physique des aérosols permettent d'expliquer nos résultats expérimentaux.

On déduit de nos mesures que l'aérosol radioactif se répartit de la façon suivante : une première partie plus ou moins importante, dépendant de la concentration en particules, reste sous forme de fraction libre ( $r < 10^{-7}$  cm) une seconde se fixe sur les particules de rayon inférieur à  $2 \cdot 10^{-5}$  cm. Il est à remarquer que, en chantiers, et ceci est important en radioprotection, il n'y a pratiquement pas de radioactivité fixée sur de grosses particules ( $r < 1 \mu\text{m}$ ).

#### 5. CHARGE ELECTRIQUE DES AEROSOLS PORTEURS DE $^{214}\text{Po}$

Dans les conditions de la mine laboratoire hors activité, on a mesuré la fraction d'aérosols chargés électriquement porteurs de  $^{214}\text{Po}$ . On utilise pour cela un ensemble de capteurs de Zeleny selon une méthode mise au point par RENOUX (5).

Au cours d'une première série d'expériences, on démontre que l'ensemble de l'aérosol radioactif chargé électriquement, représente environ 30 % du total de l'ensemble de l'aérosol radioactif. Dans ces mêmes expériences, on observe, après captation complète des ions  $^{214}\text{Po}$ , l'apparition d'une ionisation des particules primitivement neutres par effet couronne (1).

En analysant la radioactivité collectée par l'électrode centrale des tubes de Zeleny selon la méthode décrite par THOMAS (6), on obtient la répartition cumulée des ions  $^{214}\text{Po}$  en fonction de leur mobilité électrique (Fig. 4). On confirme la double distribution des particules radioactives : il n'y a pas d'ions dont la mobilité soit comprise entre  $8 \cdot 10^{-1} \text{ cm}^2\text{s}^{-1}$  et  $2 \cdot 10^{-3} \text{ cm}^2\text{s}^{-1}$ .

Dans ce cas également, on a appliqué avec succès les équations de BRICARD et BILLARD (7) (8) et vérifié théoriquement les résultats expérimentaux concernant la fraction libre de  $^{214}\text{Po}$  chargée ou neutre (1).

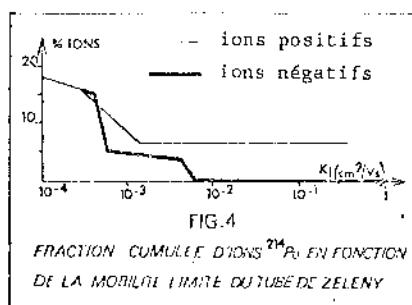

## 6. CONCLUSION

Dans la mine d'uranium laboratoire du CEA, on évalue quantitativement l'influence de la différence de pression entre la mine et l'atmosphère sur le dégagement en radon.

Une étude expérimentale et théorique basée sur la physique des aérosols et l'électricité atmosphérique a permis de mieux connaître l'aérosol des mines d'uranium hors activité et dans les chantiers. Les fractions libres des descendants à vie courte en radon ont été déterminées, une méthode de mesure a été sélectionnée pour être appliquée aux chantiers exploités.

On a vérifié la validité de différents modèles théoriques concernant la formation des noyaux de condensation radioactifs, la concentration des particules ultrafines radioactives et les ions radioactifs porteurs de  $^{214}\text{Po}$  (RaA).

## REFERENCES

- (1) Ph. DUFORT  
Thèse d'Université  
Brest 1976
- (2) J.Y. BARZIC  
Thèse de 3ème cycle  
Brest 1975
- (3) Ph. DUPOURT, G. MADELAINE, A. RENOUX  
Chemosphere, 4, (5), 283-288, 1975
- (4) J.W. THOMAS, L. HINCHLIFFE  
Aerosol Science, 3, 387-397, 1972
- (5) A. RENOUX  
Thèse  
Paris 1965
- (6) J.W. THOMAS  
Health Physics, 23, 783-789, 1973
- (7) J. BRICARD, P. GIROD, J. PRADEL  
J. de Physique, 26, 141, 1965
- (8) P. BILLARD  
Rapport interne CEA

EXTERNAL GAMMA-RADIATION AND OPERATOR PROTECTION  
IN THE MINING AND TREATMENT OF HIGH-GRADE URANIUM ORE

G.J. Wenk

The Australian Mineral Development Laboratories  
Flemington Street, Frewville, South Australia 5063

## 1. INTRODUCTION

Amdel has investigated aspects of radiation protection in the mining and processing of uranium ore from a high-grade deposit in the Northern Territory, Australia, in order to assist in the formulation of the design specifications for plant and equipment.

To achieve radiological safety, there is a need to examine what happens to the uranium and its daughter products during each phase of the operations. At most uranium mines and treatment plants, attention is mainly directed to radon and its daughter products since control of gamma exposure is not generally a problem with maximum dose-rates in working areas being about 1 mrem/h or less. However, with the high-grade ores it is also necessary to pay attention to the external gamma-radiation levels, and so calculations and measurements of gamma dose-rates for high-grade uranium ore and its associated products have been considered for radiation protection planning.

## 2. GAMMA DOSE-RATE CALCULATIONS

For external doses around the mine and plant near active units (i.e. tanks, stockpiles, mills etc.), only gamma-radiation usually needs to be considered and the inverse square range law approximation is not valid. The dose-rate resulting from different configurations of sources can be quite complex, and the fall-off of dose-rate with range,  $r$ , no longer follows a simple law.

The calculations of the radiation flux due to a distributed source, i.e. a linear, surface, or volume source, as a function of distance, makes use of the fundamental principle that any distributed source can be treated as a summation of point sources (e.g. Ref. (1)).

Because of the great variation that exists in the parameters involved, it was decided to set up mathematical models based on the following concepts.

- a. The configuration is taken to be as close as possible to the real situation. When the dose-rates can only be calculated with difficulty, the mine or plant source is represented by a source of different shape, so that the approximate configuration provides an easier means of calculating the dose-rates. For example, a plane disc can be used for plane surfaces; a truncated right-circular cone can be used for points on the axis of a cylinder.
- b. Material is generally assumed to be mixed homogeneously within the source. An exception is any settling tank, where a definite settled part is assumed to be beneath clear water or solution. Within this stipulated source the active material is taken to be evenly distributed.
- c. Self-absorption of the source is determined by the absorption coefficients selected for each gamma energy and by the material distribution.
- d. The equilibrium of uranium and daughter products is assumed to be secular. This may often be correct, but it can vary from one part

- of the orebody to another, and can change at each stage of processing. Where uranium has been extracted to leave radium, we are assuming radium to be in secular equilibrium with its daughter products.
- e. The gamma-ray energy has been divided into two groups based on the spectrum given in Ref. (2). This gives an equivalent of 1.5 photons at 0.5 MeV and 0.75 photons at 1.55 MeV for each U-238 disintegration. In one example considered, the gamma-ray spectrum treated as one mean energy gives a total dose-rate 7.5% lower, but dividing the spectrum into three or four energy groups makes no significant difference (less than 0.8%).
  - f. Shielding is assumed to be present. Generally, 6 mm steel walls have been taken for the tanks, which could have a transmission of about 90% (i.e. 60% for the uncollided flux, but multiplied by a factor of 1.5 to allow for build-up). Results given in Ref. (3) for 'shallow and medium' shielding have been used.
  - g. The field positions have been chosen in the horizontal plane of maximum surface dose-rate. This ensures that the calculations are on the conservative side for safety considerations. There may be higher surface dose-rates at surfaces above or directly underneath some sources (e.g. maintenance access-ways under settling tanks) and these are looked at separately.
  - h. Range laws of the gamma-radiation flux are determined and vary (as expected) from:  $\phi \propto r^0$  very close to a source, to:  $\phi \propto r^{-2}$  distant from a source. Approximations are used to simplify these calculations, e.g. by using equivalent plane discs for plane surfaces, or interpolation in families of plots for curved cylindrical surfaces.
  - i. Gamma-radiation flux is converted to exposure rates (measured in roentgens, R, per hour) in air at NTP. In this case, a whole body exposure of 1R can be assumed to give a body dose (absorbed) of 1 rad, or dose equivalent of 1 rem.

### 3. COMPARISON BETWEEN CALCULATED AND MEASURED DOSE-RATES

Gamma dose-rate measurements were made at Amdel (with ratemeters accurate to  $\pm 10\%$ , or  $\pm 0.1$  mrem/h at low values) during pilot plant tests on 8.5%  $U_3O_8$  ore. These are shown below, together with dose-rates (in brackets) calculated according to the above criteria.

Condition	Measured (mrem/h)		Equivalent plant condition
	Side surface	1 m away horizontal	
Ore (in 44-gall. drum)	18 (14)	0.9 (0.7)	Ore
Leaching, initial (in 40-gall. tank)	8.0 (7.6)	-	Slurry feed
Leaching, after 10 hrs	2.5	-	Leaching tank
Partly washed, settled	7.0	0.6	-
Fully washed, settled	8.5 (6.5)	0.6	CCD tank
Fully washed, stirred	7.5	0.6	-
Pregnant liquor (in beaker)	0.05	-	Preg. liquor

Estimates of the gamma dose-rates on large areas of ore have been calculated assuming an infinite slab of ore, selected values being as follows:

Grade of $U_3O_8$ (% by wt)	30	10	2.5	1	0.5	0.1
Dose-rate (mrem/h)	73	26	6.7	2.7	1.34	0.27



Geologists working on a high-grade orebody confirm that these are good approximations to their measurements (Ref. (4)), and accept that the calculated values provide a satisfactory basis for predicting exposures.

#### 4. EXAMPLES OF TYPICAL SITUATIONS

Potential exposures have been considered in several situations of mining and treatment operations (e.g., around stockpiles, in crushing and grinding areas, and near pipes and conveyor belts). Examples of some other situations are presented here. The worst conditions likely to occur as specified in the preliminary mining and metallurgical designs were considered.

##### 4.1 Open-Cut Mine and Tailings Disposal Areas

Gamma dose-rates at an open-cut mine have been calculated assuming infinite slabs of ore, values being as presented above. Simple allowances can be made for different geometrical arrangements, such as a 30%  $U_3O_8$  face on a 10%  $U_3O_8$  floor giving respective contributions of 36.5 and 26 mrem/h and a total of 62.5 mrem/h along the intersection.

From the calculated values, it can be estimated that a large slab of 0.94%  $U_3O_8$  ore would give a surface dose-rate of 2.5 mrem/h and an operator working on it for 40 hours/week would receive a whole body dose of 5 rem/year.

Using such data, mine and stockpile operator schedules can be planned, and special shielding provided on equipment, in order to fulfil radiation protection requirements.

We can treat the tailings in a similar way, but we consider them to be on average the original grade of  $U_3O_8$  with the  $U_3O_8$  removed while retaining all the radium originally present. For example, a 2.5%  $U_3O_8$  grade ore will give tailings with a dose-rate of 7.2 mrem/h on the surface; this can be reduced to a negligible level through a soil embankment one metre thick.

Examination of some Australian uranium tailings dams, several years after operations stopped, has shown classification of the tailings. Some slimes gave dose-rates up to 7 times the average amount in some areas.

##### 4.2 Cab of an Ore-Truck

We have considered the case of a rear-dump truck carrying 30%  $U_3O_8$  ore in the tray filled only to the top of the sides, and standing on 10%  $U_3O_8$  ore.

Using actual experimental gamma-radiation transmission measurements for the truck in question, estimates were made of radiation contributions the driver would receive from different directions.

A summary of the situation shows that with no extra shielding, the total dose-rate would be 29.5 mrem/h. With special shielding of 5 cm steel behind and 3 cm steel below the cab, this is reduced to 6.8 mrem/h. It would be appropriate to make dose-rate measurements on a truck on site with ore of known grade before the truck is finally modified.

##### 4.3 Vicinity of Leaching and CCD Plant

We have considered the tanks specified below as cylindrical sources, and assumed an average ore grade of 2.5%  $U_3O_8$ . Gamma dose-rates calculated in

the horizontal plane of maximum radiation, and for end-on positions are summarised.

	Dose-rates (mrem/h)			
	At the Side		Above cover	Under metal tank
	On surface	3 m away		
Neutral Slurry Tank (6m OD, 4m depth of 60% solids slurry)	3.6	0.9	5.7	-
Leaching Tank, no extraction (4m OD, 3.75m depth of 60% solids slurry)	3.2	0.6	5.0	-
CCD Tank, last tank, lowest absorption (11m OD, equivalent to 0.7m depth of 50% solids below a 2.3m depth of solution)	3.6	1.4	0	5.7
Tailings Neutraliser Tank (3m OD, 2.75m depth of 50% solids)	2.3	0.3	3.6	-

Summation of the surface dose-rates will show if some groupings of tanks are unsuitable. For example, in the space between two CCD tanks close together, the dose-rate can be approximately 7 mrem/h, and it may be undesirable to increase this with another active tank nearby.

#### 4.4 Dose-Rate Contours around Plant Layout

With any grouping of active units, the radiation field can be determined from the surface dose-rate of each unit, its range law, and position. A computer program has been used to give contour plans of the integral dose-rate around plant layouts in order to improve the layout for radiation protection requirements. For example, contours for a specified arrangement of such plant units, covering an area of 87 m x 48 m, was plotted. The positions of the tanks were spread out, covering 126 m x 68 m, so that pathways with dose-rates below 2.5 mrem/h could be made between every pair of units.

### 5. CONCLUSIONS

High-grade uranium ores pose particular problems with external gamma-radiation not encountered with low-grade ores. Relatively simple calculation procedures have been established and shown to estimate the gamma dose-rates in the mining and processing of such ore to a sufficient accuracy for planning protective measures.

The potential exposures can be examined while designs are being formulated. Equipment can be specified, procedures adopted, and plant layout improved to give acceptable radiation protection to operators in advance of final design and construction.

### 6. REFERENCES

- (1) FITZGERLAD, J.J., BROWNWELL, G.L., and MAHONEY, F.J. (1967). *Mathematical Theory of Radiation Dosimetry*; New York: Gordon and Breach.
- (2) URQUHART, D.F. (1973). *Gamma-ray spectra of uranium and thorium ores by high resolution Ge(Li) spectrometry*. AAEC Report TM634.
- (3) PRICE, B.T., HORTON, C.C., and SPINNEY, K.T. (1957). *Radiation Shielding*; London: Pergamon Press.
- (4) RANDALL, M.H., (1976), Private Communication, Queensland Mines Ltd.

$^{210}\text{Pb}$  AND  $^{210}\text{Po}$  URINE CONCENTRATION IN SUBJECTS  
WORKING IN RADON SPA

F. Breuer<sup>o</sup>, G.F. Clemente<sup>oo</sup>, A. Renzetti<sup>oo</sup>,  
G. Santori<sup>oo</sup>

<sup>o</sup>DISP-CNEN-C.P. 2400-00100 ROMA (ITALY)

<sup>oo</sup>Laboratory of Radiation Toxicology CSN-  
Casaccia-CNEN-C.P. 2400-00100 ROMA (ITALY)

### I. INTRODUCTION

Radon decay products were considered as the main contributors to the radiation lung exposure of subjects exposed to abnormal levels of Radon and daughter products in the atmosphere. In case of uranium miners many efforts have been made to correlate this exposure with the Pb-Po $^{210}$  concentration in bone, blood and urine of the exposed people (1-12). The high exposure, due to Radon and daughter products, found in some Italian radon spa suggests a research program designed to assess the Pb-Po $^{210}$  levels and their metabolism in some exposed subjects.

Furthermore, the differences in some environmental factors (as dust content, humidity, AMAD etc) between mines and spa can give important differences in both the metabolic behaviour of Radon daughters and the resulting radiation doses.

### 2. METHODS

Some radon spa have been selected in the Ischia island (Naples, Italy) according to different levels of exposure and few workers of each radon spa have been followed up. The urine samples of each subject have been collected for a period of 2 days in May, July and October 1976. The yearly working period for radon spa is approximately of 6-7 months, from April to October.

The Radon and daughters have been measured in the spa atmosphere by means of the techniques described in ref. 13 and the corresponding exposures in Working Level Months (WLM) have been evaluated. The analytical procedure employed to determine Pb- $^{210}$  and Po- $^{210}$  has been described previously (14-15). The samples were wet ashed in nitric acid and sulfuric acid and a coprecipitation of Polonium is obtained with manganese dioxide. The Po- $^{210}$  plated on silver disc is measured by means of solid state detector alpha spectrometry; the Pb- $^{210}$  was calculated from the Po- $^{210}$  ingrowth in the sample by repeating the Po- $^{210}$  analysis 3-5 months after the initial analysis. The Po- $^{210}$  values were corrected for decay and ingrowth from Pb- $^{210}$  to obtain the concentration at the sampling time. The chemical yield of any chemical analysis is tested by using the Po-208 as an internal standard. The Pb-Po $^{210}$  mean value (referred to urine samples) in the blank is 0,045 pCi/l; the Po- $^{210}$  concentration in urine for non exposed Italian subjects is in the range 0.25 - 0.60 pCi/l (15).

### 3. RESULTS AND DISCUSSION

In table I are reported the Pb-Po $^{210}$  urinary concentrations for 6 subjects

TABLE I

$^{210}\text{Pb}$  -  $^{210}\text{Po}$  urinary concentration (pCi/l)  $\pm 2\sigma$  for some of the spa workers sampled.

Subject No	$^{210}\text{Po}$ Urinary Concentration		$^{210}\text{Pb}$ Urinary Concentration	
	may	july	may	july
1	4.3 $\pm$ 0.2	5.5 $\pm$ 0.3	-	4.6 $\pm$ 0.8
2	4.1 $\pm$ 0.6	1.9 $\pm$ 0.3	1.6 $\pm$ 1.0	1.7 $\pm$ 0.5
3	2.1 $\pm$ 0.1	1.6 $\pm$ 0.2	-	1.7 $\pm$ 0.5
4	2.2 $\pm$ 0.1	2.1 $\pm$ 0.2	0.0 $\pm$ 0.4	2.2 $\pm$ 0.5
5	1.2 $\pm$ 0.1	1.0 $\pm$ 0.2	-	1.5 $\pm$ 0.4
6	0.89 $\pm$ 0.14	1.8 $\pm$ 0.2	0.76 $\pm$ 0.36	1.2 $\pm$ 0.3

TABLE 2

$^{210}\text{Pb}$ - $^{210}\text{Po}$  skeletal burdens, WLM exposure, working period and skeletal dose for some of the spa workers sampled.

Subject No	Skeletal Burden(nCi)		Exposure (WLM)	Working period (yrs)	Dose to Skeleton (rem/y)
	$^{210}\text{Po}$	$^{210}\text{Pb}$			
1	30	40	348	26	40
2	25	33	°	°	34
3	11	14.7	200	15	15
4	15	20	12	25	20
5	7	9.3	3.7	32	9.5
6	7	9.3	270	20	9.5

°Unclear working history

among the 15 spa workers sampled. The data referred to the October sampling and to the other subjects will be reported during the oral presentation. An analysis of all the available data seems to indicate a quite constant Po-210 excretion, almost independent upon the recent exposure, and a Pb-210 excretion increasing as a function of recent exposure. Such a result could indicate a fast clearance for the Pb-210 (formed by the inhaled Radon daughters) lung content, due to the recent exposure, and a Po-210 excretion practically attributable to the skeletal burden only. This hypothesis is in good agreement with the physical characteristics of the aerosol typical of radon spa (very low AMAD, high humidity, absence of dust).

As a consequence the metabolic pathway of Pb-Po210 in spa workers seems to be completely different from the one obtained in Uranium miners, where a significant part of the Po-210 excretion is caused by the slow clearance of the activity contained in the lung, thus permitting the decay of Pb-210 to Po-210 and the Po-210 accumulation in the lung.

Assuming a Po/Pb ratio in human bone equal to 0.75, obtained from experimental data on miners (9), and a long-live component biological half-time for Pb-210 in human bone of 5000 days (16), the biological half-time for the Po-210 skeletal burden has been calculated and resulted to be of about 400 days. The daily Po-210 total excretion for each subject has been obtained from the Po-210 urinary concentration (table 1) on the basis of the daily urinary excretion (17) and of a 10% fractional Po-210 urinary excretion (18-19). Thus, the Po-210 skeletal burden for each subject, estimated by using the daily total excretion and the biological half-time, are reported on table 2; the Pb-210 skeletal burdens (table 2) are calculated on a Po/Pb ratio equal to 0.75 (9), as reported before. In table 2 are also given the exposures in WLM, evaluated on the basis of both the measurements performed in the spa atmosphere during working periods and the working history of the subjects. A significant correlation ( $r=0.77$ ) has been found between WLM and urinary Po-210 excretion in all subjects. The doses to the skeleton (table 2) have been estimated according to the hypothesis and the formula given by Blanchard (9), and using a skeleton weight of 5000 g (17) and the skeletal Po-210 burdens reported in table 2.

The lung dose was not evaluated, owing to the uncertainties regarding the relationship between exposure and dose also in the case of Uranium miners. The average annual exposure can be obtained on the basis of both the WLM and the working period given in table 2.

The skeletal doses (table 2), and the average annual lung exposure are exceeding in some cases those recommended by ICRP for an occupationally exposed population (20), thus showing the importance of the exposure due to the radon spa.

#### REFERENCES

- (1) Djuric, D., et al., Polonium in the urine of miners as a measure of exposure to Radon, vol. II, p. 431, Radiological Health and Safety in Mining and Milling of Nuclear Materials, IAEA, Vienna (1964)
- (2) Inouye, T. et al., The level of Polonium in urine of Japanese Uranium miners, vol. II, p. 425, Radiological Health and Safety in Mining and Milling of Nuclear Materials, IAEA, Vienna, (1964)

- (3) Archer, V.E., et al., Urine and tissue content of Pb-210 and Po-210 in Uranium miners, p. 553, *Diagnosis and Treatment of Deposited Radionuclides* (Kornberg, H.A., Norwood, W.D., Eds), Excerpta Medica Foundation, Dordrecht (1968)
- (4) Black, S.C., et al., Correlation of radiation exposure and Pb-210 in uranium miners, *Health Phys.* 14 (1968) 81
- (5) Blanchard, R.L. et al., Blood and skeletal levels of Pb-Po210 as a measure of exposure to inhaled Radon daughter products, *Health Phys.* 16 (1969) 585
- (6) Raabe, O.G., Concerning the relationship of Pb-210 and inhalation exposure to Radon, *Health Phys.* 18 (1970) 733
- (7) Holtzmann, R.B., Sources of Pb-210 in Uranium miners, *Health Phys.* 18 (1970) 105
- (8) Holgye, Z., Probleme der exkretionsanalyse von Po-210 bei bergleuten in der Uraninindustrie, *Strahlentherapie* 140 5 (1970) 573
- (9) Blanchard, R.L., Moore, J.B., Body burden, distribution and internal dose of Pb-210 and Po-210 in a Uranium miner population, *Health Phys.* 21 (1971) 499
- (10) Novak, L.J., Panov, D., Po-210 in blood and urine of Uranium mine workers in Yugoslavia, *Amer. Ind. Hyg. Assoc. J.* 33 (1972) 192
- (11) Cohen, N., et al., Pb-210 concentrations in the bone, blood and excreta of a former Uranium miner, *Health Phys.* 24 (1973) 601
- (12) Blanchard, R.L., et al., Pb-210 blood concentration as a measure of Uranium miner exposure, *Health Phys.* 25 (1973) 129
- (13) Sciocchetti, G., Assessment of airborne radioactivity in the Italian mines, Proc. of the meeting on Personal Dosimetry and Monitoring suitable for Radon and Daughter Products, Elliot Lake, Canada, October 4-8, 1976, to be published by OECD
- (14) Eakins, J.D. Morrison, R.T., The determination of Po-210 in urine by coprecipitation with manganese dioxide, *AERE report R-7923* (1975)
- (15) Santori, G., Renzetti, A., Metodi per la determinazione di Pb-Po210 in campioni biologici, Proc. of the meeting of AIFSPR, Pisa October 27-29, 1976, to be published
- (16) Lloyd, R.D. et al., Pb-210 studies in beagles, *Health Phys.* 28 (1975) 575
- (17) Report of the Task Group on Reference Man, ICRP publication 23, Pergamon Press, Oxford (1975)
- (18) Report of Committee IV on Evaluation of Radiation Doses to Body Tissues from Internal Contamination due to Occupational Exposure, ICRP publication 10, Pergamon Press, Oxford (1968)
- (19) Globel, B., et al., Aufnahme und Ausscheidung der natürlichen Radionuklide Pb-210 und Po-210 durch den Menschen, *Strahlentherapie* 131 (1966) 218
- (20) Report of Committee II on Permissible Dose for Internal Radiation, *Health Phys.* 3 (1960) 12

CONFORMITE' DES CHOIX DE PROJET AVEC LES OBJECTIFS DE PROTECTION RADIOLOGIQUE POUR UNE USINE DE FABRICATION DE COMBUSTIBLES A PLUTONIUM.

A. Cardinale - P. Ottati : Agip Nucleare - Milan - Italie

\*\*\*\*\*

1. Classification des conditions d'accident

Le projet d'une installation nucléaire doit forcément se baser sur des critères de sécurité qui protègent soit le travailleurs soit la population résidant aux alentours contre les risques indus venant des radiations produites par l'installation en condition d'opérations normales et en cas d'accident. Suivant les méthodologies actuelles, surtout dans le cas des reacteurs nucléaires, qui sont les installations ayant la plus grande diffusion, on fixe des critères globaux d'acceptabilité(1)(2), associant la fréquence des accidents possibles aux valeurs maximales de rejet de matériel radioactif, de sorte que le risque global venant de l'installation, c'est-à-dire le terme

$f_i R_i$  ( $f_i$  = fréquence;  $R_i$  = Rejet), soit limité à une valeur déterminée, qui représente le risque acceptable pour l'installation. Evidemment, puisqu'il n'est ni possible ni pratique de calculer la fréquence de chaque accident prévu, on utilise une classification des conditions accidentales par catégories qui rassemblent les accidents en bandes de fréquence assez larges.

En ce qui concerne une usine de fabrication d'éléments combustibles à oxydes mixtes U-Pu, une des classifications possibles est la suivante(3):

- Categorie 1 - Conditions d'opérations normales et transitoires d'opérations: Elle comprend toutes les conditions de fonctionnement normales de l'usine, p. ex. déplacement du matériel, frittage, récupération des déchets, remplacement des filtres et des gants etc.

- Categorie 2 - Accidents avec fréquence modérée: Elle comprend les accidents qui peuvent se produire pendant le fonctionnement de l'usine, la fréquence globale étant de quelques-uns par an(1-10). Les accidents peuvent provoquer un rejet de Pu à l'intérieur de la zone contrôlée mais il n'y a aucun rejet de Pu au dehors. Une action de protection peut se rendre nécessaire, mais l'usine ne doit pas être arrêtée.

- Categorie 3 - Accidents ayant une basse probabilité: Elle comprend les accidents qui ont la probabilité globale de se produire seulement quelques fois pendant la vie de l'installation( $10^{-1}$ - $10^{-2}$  événements globaux/an). Ces accidents peuvent provoquer l'arrêt de l'usine pour remise en état de travail.

- Categorie 4 - Accidents limites: Elle comprend des accidents non prévisibles mais qui doivent être pris en considération puisque leur conséquences pourraient causer des rejets considérables de matériel radioactif. La probabilité globale de ces accidents est d'environ  $10^{-6}$  événements/an. Comme désormais on accepte normalement des accidents ayant une probabilité sensiblement inférieure à  $10^{-6}$  événements/an sont à considérer "incroyables" et on ne les prend donc pas en considération, en ce qui concerne la définitions du critère global d'acceptabilité. Dans les paragraphes suivants, nous nous limitons à considérer seulement les implications venant de la classification dans des catégories accidentales pour la protection radiologique des personnes qui travaillent à l'intérieur de l'usine.

2. Objectifs de protection radiologique proposés pour l'intérieur d'une usine plutonium.

On considère que l'absorption de doses de la part des travailleurs soit principalement due à inhalation de Pu, à la suite de la contamination de la zone de travail. Suivant la classification donnée au paragraph 1, on considère, pour la protection des travailleurs, les catégories 1 et 2 qui se rapportent, respectivement, aux conditions d'opérations normales et transitoires d'opérations et aux accidents ayant une fréquence modérée. Le critère fondamental proposé est donné par la limitation, dans la phase de projet de l'usine, de la contamination de l'air, à l'intérieur de la zone contrôlée, à 1/3 de la CMA pour les travailleurs ( $2 \cdot 10^{-12}$  Ci/m<sup>3</sup>) pour les deux catégories 1 et 2. Sur la base de l'expérience de fabrication de combustibles U-Pu, il est raisonnable de supposer que des contaminations anormales de l'air puissent se vérifier chaque année à deux différents niveaux (10CMA e 100CMA), tandis que le niveau normal ne dépasse pas 0,1CMA(4). Si l'on considère 2000 h de travail par an, il est possible d'établir le nombre d'heures par an pendant les quelles les dites contaminations peuvent se vérifier. En effet il résulte:  $x_1 \cdot 0,1 \text{ CMA} + x_2 \cdot 10 \text{ CMA} + x_3 \cdot 100 \text{ CMA} \leq 2000 \cdot 1/3 \text{ CMA}$  avec la condition accessoire:  $x_1 \cdot 0,1 \approx x_2 \cdot 10 \approx x_3 \cdot 100$ .

Il est possible de proposer les objectifs suivants:

Catégorie 1  $\left\{ \begin{array}{l} \text{conditions d'opérations normales} \quad x_1 = 1978 \text{ h/an à } 0,1 \text{ CMA} \\ \text{transitoires d'opérations} \quad x_2 = 20 \text{ h/an à } 10 \text{ CMA} \end{array} \right.$

Catégorie 2 - Accidents de fréquence modérée  $x_3 = 2 \text{ h/an à } 100 \text{ CMA}$

Ces valeurs pourront être utilisés pour la définition, au cours de la phase de projet, de certains caractéristique du système de ventilation, du confinement primaire et du système de contrôle de la contamination de l'air.

3. Répercussions des objectifs de protection radiologique sur les systèmes de ventilation et de contrôle de la contamination atmosphérique.

Pour analyser les implications des objectifs de protection radiologique considérés, il faut examiner un cas concret. On considère, à l'intérieur d'une usine de fabrication de combustibles à Pu, une cellule "chaude", isolée, en ce qui concerne la ventilation, par rapport aux autres cellules. La répartition homogène dans l'espace de la contamination correspond à un cas idéal assez bien réalisé lorsque la source d'émission est de grande dimension ou le renouvellement de l'air est suffisant. On admet que les bouches d'introduction de l'air et celles d'aspiration soient disposés de façon que la totalité du volume soit ventilée. Au cas où un événement imprévu causerait une augmentation de la concentration de Pu dans l'air de la cellule pour manque de confinement, si l'émission peut être arrêtée par des opérations simples qu'on puisse considérer de routine, il serait possible de schématiser la variation de la contamination selon le temps (5):

$$C = \frac{a}{RV} (1 - e^{-Rt}) \quad 0 < t \leq T \quad \left. \begin{array}{l} \text{où } C = \text{concentration dans l'air (Ci/m}^3\text{)} \\ a = \text{émission (Ci/h)} \\ V = \text{volume de la cellule (m}^3\text{)} \\ R = \text{renouvellement de l'air par heure} \\ t = \text{temps écoulé depuis le début de l'émission} \end{array} \right\}$$

$$C = \frac{a}{RV} e^{-R(t-T)} \quad T < t < \infty$$

et T-temps nécessaire pour détecter la contamination et pour arrêter l'émission



$$\text{d'où l'on obtient : } \int_0^{\infty} C dt = \frac{a}{RV} \left[ T + \frac{2}{R} e^{-RT} - \frac{1}{R} \right]$$

Si l'on considère que ces types d'événements peuvent se vérifier plusieurs fois au cours d'une année il en résulte une contamination annuelle, donnée par  $\sum_{i=1}^n a_i \left[ \frac{1}{RV} \left( T + \frac{2}{R} e^{-RT} - \frac{1}{R} \right) \right]$ , qui est égale, pour chacune des deux

classes d'événements anormaux qu'on a considéré au paragraphe précédent, à :  $4 \cdot 10^{-10}$  (Ci h/m<sup>3</sup> an). A l'intérieur de la même classe il est raisonnable de penser que la variation de la concentration avec le temps suit à peu près la même loi, donc  $\sum_{i=1}^n a_i = n\bar{a}$ . On peut donc, optimiser les caractéristiques des systèmes de ventilation et de contrôle de la contamination, tout en tenant fixe la valeur de la contamination annuelle de l'air dans la cellule. Tel qu'un exemple on peut considérer une cellule ayant un volume de 1000 m<sup>3</sup>. Sans entrer dans le détail du problème du contrôle de la contamination du Pu dans l'air, on suppose qu'on puisse choisir parmi trois différents systèmes dont la sensibilité soit, respectivement, de 5, 10 et 20 CMA x h. On peut considérer que le temps T est dû à l'addition d'un temps T<sub>1</sub> nécessaire pour la détection et d'un temps T<sub>2</sub> nécessaire pour arrêter l'émission. On suppose que le temps T<sub>1</sub> soit le même pour tous les événements et, dans le cas qu'on étudie, il est considéré égal à 0,4 h, temps nécessaire, selon une estimation prudente, pour le remplacement d'un gant. On peut donc considérer la série de valeurs T suivante:

<p>Catégorie 1</p> <p>T<sub>1</sub><sup>1</sup> = 0,9 h</p> <p>T<sub>2</sub><sup>1</sup> = 1,4 h</p> <p>T<sub>1</sub><sup>2</sup> = 2,4 h</p>	<p>Catégorie 2</p> <p>T<sub>1</sub><sup>1</sup> = 0,5 h (pour 5 CMA x h)</p> <p>T<sub>2</sub><sup>1</sup> = 0,5 h (pour 10 CMA x h)</p> <p>T<sub>2</sub><sup>2</sup> = 0,6 h (pour 20 CMA x h)</p>
---	--

En ce qui concerne la ventilation, il est raisonnable de choisir entre les valeurs R suivantes : 5, 10 et 15 Renouv/h. Le nombre d'événements accidentaux correspondant à chaque cas peut être défini, selon une estimation prudente, en supposant que la durée totale de l'événement soit T +  $\mathcal{F}$ , où  $\mathcal{F}$  est le temps dans lequel la concentration de Pu redescend à la valeur de fond (0,1 CMA) entre 10%; Pour les deux catégories on a respectivement:

$$R \mathcal{F}_1 = 4,5 \qquad R \mathcal{F}_2 = 6,8$$

En table 1 on illustre les valeurs de n<sub>1</sub><sup>1</sup> et n<sub>2</sub><sup>1</sup> et de  $\bar{a}_1$  et  $\bar{a}_2$  qui correspondent aux différentes valeurs du nombre de renouvellement/heure et de sensibilité de détection considérées.

Sensibilité de détection	R = 5				R = 10				R = 15			
	n <sub>1</sub> <sup>1</sup>	$\bar{a}_1$	n <sub>2</sub> <sup>1</sup>	$\bar{a}_2$	n <sub>1</sub> <sup>1</sup>	$\bar{a}_1$	n <sub>2</sub> <sup>1</sup>	$\bar{a}_2$	n <sub>1</sub> <sup>1</sup>	$\bar{a}_1$	n <sub>2</sub> <sup>1</sup>	$\bar{a}_2$
5 CMA x h	11	0,25	1	3,2	15	0,34	2	5	17	0,42	2	7
10 CMA x h	9	0,18	1	3,2	11	0,28	2	5	12	0,38	2	7
20 CMA x h	6	0,14	1	4,8	7	0,24	2	4	7	0,36	2	5,6

Table 1: Nombre de pannes par an et valeurs moyennes d'émission de Pu ( $\mu$ Ci/h) pour les deux classes considérées.

Sans baisser l'assurance concernant la contamination annuelle de l'air de la cellule, on peut donc optimiser le choix du nombre de renouvellements/heure et du système de contrôle de la contamination dans l'air. Un nombre de renouvellements/heure plus bas comporte l'exigence d'assurer un nombre

plus bas de pannes et par conséquent un meilleur confinement primaire (boîtes à gants). On obtient le même résultat si la sensibilité du système de contrôle est inférieure. Les valeurs de la table 1 peuvent, donc, être utilisées pour établir les niveaux de qualité de certains composants de l'usine.

#### 4. Evaluation du niveau de qualité du système de ventilation des boîtes à gants.

Pour effectuer cette évaluation il est nécessaire de fixer certains choix du projet, à partir des hypothèses du paragraphe précédent. De plus, il est nécessaire de fixer le nombre des boîtes à gants qui sont à l'intérieur de la cellule. On assume d'avoir effectué les choix suivants:

$R = 10$  Renou/h      sensibilité de détection  $\cdot 10$  CMA x h  
d'où :  $n_1 = 11$ ,  $\bar{a}_1 = 0,28 \mu\text{Ci/h}$        $n_2 = 2$        $\bar{a}_2 = 5 \mu\text{Ci/h}$   
De plus on assume que la cellule comprenne 4 boîtes à gants, ayant un volume de  $\sim 10 \text{ m}^3$  chacune. Les boîtes à gants ont un taux de fuite de  $3 \cdot 10^{-3}$  volumes/heure (6) et la concentration d'aérosols à l'intérieur est de  $10^{-3} \text{ g/m}^3$  particules dans le domaine respirable, ce qui représente 1% de la valeur de saturation (7). L'arrêt du système de ventilation des boîtes à gants peut provoquer la suppression et l'émission de radioactivité dans la cellule. Suivant les hypothèses données, l'émission de Pu sera égale à  $3 \cdot 10^{-5} \text{ g/h}$ . Si le plutonium est Pu-239 a  $2 \mu\text{Ci/h}$ .

Une panne de ce type est comprise dans la catégorie 2, pour laquelle on peut accepter 2 pannes par an au maximum, avec une émission moyenne de  $5 \mu\text{Ci/h}$ . Puisque dans la cellule on a 4 boîtes à gants il faut garantir qu'un accident de suppression ne se vérifie qu'une seule fois par an pour chaque boîte.

#### - Bibliographie

- (1) - Renato Zambrini: "Sulla caratterizzazione dei siti nucleari"-Sicurezza Nucleare e Protezione Sanitaria 1-Notiziario CNEN n°3, marzo 1975;
- (2) - USAEC- Rasmussen et al: "Reactor Safety study- WASH 1400-August 1974; Draft
- (3) - ANSI N 287: "Criteria for siting, design and operation of plants for the Manufacture of mixed oxide (U-Pu) fuels"-july 1974-Draft;
- (4) - Recycle Fuels Plant - License Application - Westinghouse Nuclear Fuel Division - July 1973;
- (5) - J. P. Perotin, B. Werderer: "La contamination radioactive des ateliers et laboratoires" - Note Cea n°1408(2)- février 1971;
- (6) - Safe Handling of plutonium - Safety Series n°39 - IAEA 1974;
- (7) - Considerations in the assessment of the consequence of effluents from mixed oxide fuel fabrication plants - BNWL 1697 UC-41 - June 1973.

DIX ANS D'EXPERIENCE DANS LA FABRICATION  
DES ELEMENTS COMBUSTIBLES AU PLUTONIUM

H. BAILLY, M. GANIVET, H. GUILLET, G. MAGAUD, J. R. PAJOT, J. L. VIALARD  
Commissariat à l'Energie Atomique  
Cadarache

---

## 1. INTRODUCTION

Le fonctionnement des réacteurs à Neutrons Rapides de la Filière Française, Rhapsodie, Phénix et ultérieurement Super-Phénix, nécessite la mise en oeuvre de quantités importantes de plutonium pour la fabrication des éléments combustibles.

Les éléments combustibles de ces réacteurs se présentent sous forme d'assemblages composés essentiellement d'un faisceau de tubes en acier, remplis d'un empilement de pastilles frittées en oxyde mixte d'uranium et de plutonium. Leur fabrication est réalisée dans les installations du CEA, à Cadarache, à l'intérieur du Complexe de Fabrication des Eléments Combustibles au Plutonium, qui comprend un atelier de fabrication et un laboratoire d'analyses et de retraitement de déchets.

Depuis plus de 10 ans, cette installation a traité la presque totalité du plutonium civil français, soit environ 4 t de plutonium. Son fonctionnement est assuré par environ 140 agents du CEA.

La mise en oeuvre progressive de quantités de plus en plus importantes de plutonium a pu être réalisée grâce à l'évolution des équipements et des procédés, tout en poursuivant une amélioration constante de la sécurité et de la protection des opérateurs.

Les risques d'origine nucléaire auxquels sont soumis les opérateurs pendant la transformation du plutonium en éléments combustibles sont essentiellement : le risque de contamination, le risque d'irradiation et le risque d'accident de criticité.

## 2. RESULTATS D'EXPLOITATION DU COMPLEXE DE FABRICATION

Les résultats d'exploitation sont donnés ci-après, pour la contamination et pour l'irradiation.

### 2.1 Incidents de contamination

Le confinement du plutonium est réalisé classiquement par l'utilisation des boîtes à gants que l'on appellera "BAG" dans la suite du texte. La BAG est une enceinte étanche, maintenue en dépression par rapport à l'atmosphère, munie de gants par l'intermédiaire desquels s'effectue le travail. Un incident de contamination correspond à une rupture locale de l'étanchéité avec dispersion d'aérosols d'oxyde de plutonium dans le local de travail. Un tel incident survient le plus fréquemment au niveau du gant, barrière la plus fragile, très sollicitée au cours du travail.

La contamination qui résulte de cet incident atteint l'opérateur au niveau de ses vêtements de protection ou au niveau cutané et peut atteindre essentiellement les poumons par la voie respiratoire. La fréquence et la gravité de ce type d'incident sont des éléments d'appréciation importants pour le fonctionnement d'un atelier de fabrication. Le tableau 1 indique l'évolution de la fréquence de ces incidents pour l'ensemble du Complexe de Fabrication pour la période 1966-1975.

TABLEAU N° 1  
EVOLUTION DE LA FREQUENCE DES INCIDENTS DE CONTAMINATION

	66	67	68	69	70	71	72	73	74	75
Fréquence rapportée à un individu	1,25	0,42	1,24	1,00	1,01	1,64	1,92	1,18	0,97	0,53
Même fréquence rapportée à 100 kg de Pu traités	2,08	0,89	0,52	0,50	1,48	0,53	0,49	0,30	0,14	0,08

### 2.2 Incidents de contamination ayant entraîné une contamination interne

Les incidents de contamination ayant entraîné une contamination interne significative ont été assez rares jusque vers 1971. Dans les cinq dernières années ils se situent au niveau de 2 % environ du total des incidents de contamination.

La dose d'irradiation annuelle correspondante est en moyenne pour les 4 dernières années de l'ordre de 10 % de la limite annuelle internationale autorisée, avec un point maximal situé à 27 % de cette limite, comme indiqué dans le tableau n° 2.

TABLEAU N° 2

EVOLUTION DE LA DOSE D'IRRADIATION INTERNE INDUITE AU NIVEAU DU  
POUMON, RAPPORTEE A LA LIMITE ANNUELLE INTERNATIONALE AUTORISEE  
(15 000 mrem)

Années	72	73	74	75
Pourcentage d'individus concernés	3	5	10	10
Dose moyenne par individu concerné (%)	10	5	7	6
Dose autorisée				
Dose maximale reçue (%)	20	13	26	27
Dose autorisée				

On peut constater que depuis 1971, année à partir de laquelle ont été réalisées des productions à caractère industriel, portant sur des quantités annuelles de Pu supérieures à 300 kg, la fréquence rapportée à 100 kg traités a été divisée par un facteur 5. Pendant cette même période le nombre d'incidents n'a pas augmenté de manière significative alors que la production était multipliée par 4 et les incidents ayant entraîné une contamination interne restent dans des limites très faibles.

### 2.3 Irradiation

Le risque d'irradiation est dû essentiellement aux rayonnements X et Y des isotopes du plutonium, de l'américium et aux produits de fission à l'état de traces et, en présence de masses de Pu importantes, aux neutrons de fission spontanée ou résultant de réactions ( $\alpha, n$ ). La surveillance permanente de l'irradiation subie par le personnel est assurée par le port constant à la poitrine, aux poignets et aux doigts, pendant la durée du travail en zone contrôlée, de films dosimètres ou de détecteurs adaptés au type de rayonnement prépondérant.

Ces films donnent la dose reçue mensuellement par l'opérateur. Le tableau n° 3 indique l'évolution de la dose reçue, en valeur absolue et rapportée à 100 kg de plutonium traités pour les cinq dernières années, les valeurs antérieures étant trop faibles pour être représentatives.

TABLEAU N° 3

EVOLUTION DE L'IRRADIATION EXTERNE RAPPORTEE A LA LIMITE ANNUELLE  
AUTORISEE POUR L'ENSEMBLE DU CORPS (5000 mrem) ET POUR 100 KG  
DE Pu TRAITES

Années	71	72	73	74	75
Dose moyenne par agent (%)	13	14	9	10	8
Dose autorisée					
Dose en (h x rem) pour 100 kg de Pu traités	30	27	17	10	8

La dose moyenne par agent a diminué en valeur absolue d'environ 50 % et, rapportée à 100 kg de Pu traités, elle est divisée par 4. Les valeurs maximales constatées n'ont jamais dépassé 80 % de la dose limite annuelle autorisée.

### 3. ACTIONS D'AMÉLIORATION DES CONDITIONS DE TRAVAIL

Les résultats indiqués ci-avant ont pu être atteints grâce aux améliorations apportées aux conditions de travail et à une formation continue du personnel. Les points essentiels sur lesquels s'est développée l'action d'amélioration peuvent être indiqués ci-après.

#### 3.1 Diminution de la fréquence des incidents

- Aménagement rationnel des lignes de fabrication, avec généralisation de transferts sans rupture de charge entre les différentes BAG ou lignes de fabrication.
- Limitation du nombre de points d'entrée des produits de départ et de sortie des déchets.
- Utilisation de gants de BAG bien adaptés à chaque poste de travail, ayant une bonne tenue au vieillissement sous irradiation, accompagnée d'un programme de changement de gants.
- Mécanisation des opérations en BAG, lorsque cela est possible.
- Maintien d'une propreté intérieure rigoureuse et éventuellement confinement secondaire des produits à l'intérieur de la BAG.

#### 3.2 Amélioration de la surveillance de la contamination atmosphérique

L'exposition de l'opérateur à une contamination atmosphérique est d'autant plus limitée qu'il peut réagir rapidement et correctement.

Aussi, afin de se prémunir contre un défaut d'étanchéité non immédiatement détectable par l'opérateur, un équipement de surveillance et d'alarme a-t-il été mis en service dans les locaux soumis à un tel risque. La multiplication des points de prélèvements, le choix judicieux des emplacements auprès des postes de travail, permettent d'obtenir une surveillance suffisante des zones de travail.

Cependant, la mise en oeuvre de plutonium issus des réacteurs LWR, qui autorisent un fort taux de combustion, entraînant une augmentation importante de l'activité des isotopes du plutonium, Pu 238, Pu 240, Pu 241, nous incite à poursuivre l'effort d'amélioration en ce domaine et à rechercher, outre une surveillance constante de l'ambiance, une certaine diminution du temps de séjour de l'opérateur dans le local de travail, par des moyens divers tels par exemple, la conduite à distance des appareils.

### 3.3 Diminution des doses d'irradiation

La limitation des doses reçues est obtenue par la mise en place sur les panneaux des BAG de protections biologiques, écrans en feuilles de plomb ou panneaux de polyéthylène. Ces aménagements limitent le niveau de l'irradiation locale et ambiante.

Par ailleurs, toutes les améliorations mentionnées plus haut ont évidemment une influence sur la dose reçue par l'opérateur : propreté des BAG, changements de gants fréquents, mécanisation ou automatisation, regroupement des masses de matières fissiles dans des stockages en ligne protégés.

### 4. CRITICITE

Au delà des risques indiqués ci-avant, se situe le risque d'accident de criticité qui conduirait à des irradiations très importantes des opérateurs placés à proximité.

La sûreté vis-à-vis de ce type d'accident repose sur des études préalables, conduites au niveau de la conception et du dessin des équipements en prenant en compte toutes les conditions accidentelles envisageables. Après autorisation de mise en service, délivrée par les Commissions compétentes, la sécurité de l'exploitation repose essentiellement sur la qualité du personnel, sa connaissance détaillée et approfondie des règles et consignes de criticité et sur son sens des responsabilités. En effet, bien qu'un système informatique centralisé tienne à jour l'état permanent des stocks de matières fissiles par poste de travail, et puisse aider l'opérateur dans le choix de ses décisions, chaque transfert de matières fissiles est placé sous la responsabilité directe de l'opérateur qui l'exécute. Un tel système, pratiqué et amélioré depuis plus de 10 ans, couvre en années normales, environ 20 000 transferts de matières fissiles sans que l'on ait constaté d'erreur notable.

L'ensemble des résultats acquis depuis plus de 10 ans au cours du fonctionnement de cet atelier industriel, nous a aidé dans la conception d'un atelier de capacité plus importante destiné à la fabrication des assemblages combustibles de Super-Phénix, en adoptant comme un des principaux objectifs une nouvelle diminution des risques encourus par le personnel. Tout permet de penser que ce but sera atteint.

PARTICLE SIZE AND SOLUBILITY CHARACTERISTICS OF AEROSOLS  
IN Pu PROCESSING AREAS AND IN BWR TYPE POWER REACTORS

P. Kotrappa, I.S. Bhat, V.D. Vashi,  
C. Suryanarayanan, and S. Chandramouli  
Health Physics Division  
Bhabha Atomic Research Centre  
Bombay 400 085, INDIA.

## 1. INTRODUCTION

Evaluation of airborne radioactivity in the working environment is important in assessing the inhalation hazards to an occupational worker. For meaningful evaluation of such hazards one has to know not only the concentration of radionuclides in air, but also the particle size distribution and the solubility characteristics. Present work gives these characteristics for airborne radionuclides found in the working environment of a Pu processing area and a BWR type power reactor.

## 2. PLUTONIUM PROCESSING AREAS

### 2.1 Particle size Distribution

ICRF task group on lung dynamics (1) states that aerodynamic particle size distribution characterised by activity median aerodynamic diameter (AMAD) has to be known for predicting the deposition of inhaled material in various compartments of the respiratory tract. It has been shown that a two stage HASL cyclone sampler can be used (2, 3) for measurement of the aerosol parameter, AMAD. The method consists of taking two samples. The first one is taken on a filter paper following a half inch cyclone at a flow rate of 9 lit/min and the second one is taken on a filter paper at the same flow rate. A theoretical curve is used to calculate the value of AMAD.

As the cyclone method has an advantage of providing both the concentration of airborne Pu and the AMAD of Pu aerosol, measurements were instituted on a routine basis in an industrial scale Pu reconversion laboratory attached to a fuel reprocessing plant. The laboratory provides a variety of operations giving rise to airborne Pu. Over a period of two years (1973-1975), a total of 173 samples showing significant Pu activity were analysed. Results are shown in Table 1.

Mean AMAD ( $\mu\text{m}$ )	Range of concentration ( $\mu\mu\text{Ci}/\text{m}^3$ )	Mean concentration ( $\mu\mu\text{Ci}/\text{m}^3$ )	No. of samples	Comments
4.4	0.1 to 1.0	0.90	18	Normal
6.8	1.0 to 2.0	1.64	18	Normal
6.8	2.0 to 5.0	3.31	53	Special
7.3	5.0 to 10.0	7.26	44	Special
6.9	10.0 to 20.0	13.37	14	Special
8.3	20.0 to 100.0	43.45	16	Maintenance
9.8	100 to 1500	543.00	10	Maintenance



TABLE 1 Activity Median Aerodynamic Diameter (AMAD) and the Concentration of Airborne Pu in the Working Environment of Pu Reconversion Laboratory.

Samples commented as 'normal' were those collected during normal operations. Those commented as 'special' were taken during operations such as glove changing, minor decontaminations, ventilation failures etc. Those commented as 'maintenance' covered major operations such as repairing of glove box equipments, major decontamination etc.

Results indicate that AMAD values tend to increase with increasing concentrations. In the range of concentrations (2 to 20  $\mu\mu\text{Ci}/\text{m}^3$ ) most likely to encounter, AMAD values tend to be about 7  $\mu\text{m}$ . This is quite large compared to 1.5  $\mu\text{m}$  tacitly assumed in the derivation of currently used MPC levels (2). For such aerosols MPC can be upgraded by a factor of about 2.5. The range of values reported in this work generally agree with the other workers (2).

## 2.2 Solubility Characteristics of Pu Aerosols.

Because of the close correspondence (4) between in-vitro dissolution of aerosols in lung serum simulant to in-vivo dissolution in the lower respiratory tract, in-vitro solubility studies assume significance. Such studies have several distinct uses - (a) in case of accidental exposures, treatment of the person depends upon this property, (b) in case of known low level exposures, it is useful in calculating the material and dose commitments, (c) to decide upon whether to use MPC values for soluble or insoluble Pu.

The procedure adopted is somewhat similar to the static method reported earlier (4) Air sample collected on a glass fibre filter paper was sandwiched between the two clean glass fibre papers and the entire sandwich was mounted in a perspex holder. The holder along with the sample was immersed in 70 ml of the serum simulant contained in a 100 ml beaker. At regular intervals, the simulant was replaced by fresh solution. The solution removed was subjected to chemical separation and Pu estimation. The amount of Pu activity per unit volume of the simulant solution removed at each interval was estimated. Finally, the fraction of original activity eluted per day was calculated. Counting of samples was done for a duration sufficient to provide a coefficient of variation of less than 5%. Studies were conducted at room temperatures (25° C to 30° C).

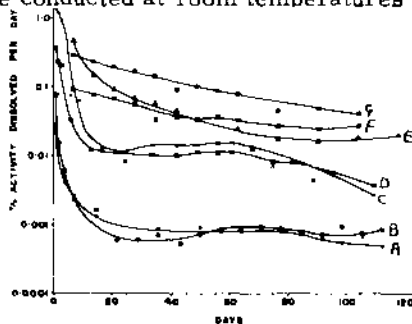

Figure 1. Solubility of Pu aerosols in lung serum simulant. A and B are for  $\text{PuO}_2$  aerosols collected from a glove box. C, D, E, F and G are for aerosols, collected from the working environment.

Figure 1 gives the results. Following conclusions can be reached: a) Air samples collected from a glove box handling  $\text{PuO}_2$  show the least solubility (b) Air samples collected from working areas indicate a long term solubility rates between 0.03 and 0.05 percent per day. Such solubility rates correspond to solubility half lives of about 1700 days and 1000 days respectively. Solubility half life is defined as the number of days needed to dissolve 50% of the material at a particular solubility rate. These half lives are somewhat larger than the range of half life (500 to 1000 days) quoted for the lung elimination half life for insoluble Pu aerosols. (c) All the samples indicate higher solubility rates in the beginning and decrease to a steady low value after 100 days.

### 3. BWR TYPE POWER STATION AT TARAPUR

Studies relating to the measurement of aerodynamic particle size distributions of aerosols found in different working areas of Tarapur Atomic Power Plant have been reported earlier (5). Present studies relate to the measurement of soluble fractions of various radio-isotopes in lung serum simulant. Particulate air samples collected on glass fibre filter paper were left in contact with the lung serum simulant maintained at a temperature of 37°C. After allowing a contact period of about six hours, the undissolved and dissolved activities were estimated by gamma spectrometry (for 60 Co, 134 + 137 Cs and 140 Ba) and by chemical separation and counting (for 90 Sr and 141 + 144 Ce). The results were analysed to arrive at the percent activity dissolved in the lung serum simulant for various isotopes. The undissolved fraction appeared to dissolve very slowly and such long term solubility rates will be studied later. Table 2 gives the results.

Sampling location	Percentage of radionuclide extracted from air filters by lung serum simulant				
	$^{60}\text{Co}$	$^{134} + ^{137}\text{Cs}$	$^{89+90}\text{Sr}$	$^{141+144}\text{Ce}$	$^{140}\text{Ba}$
<u>I-Set</u>					
1. Radwaste Building Operation gallery.	3.30	54.30	79.80	0.64	6.60
2. Radwaste Building Conveyor area	2.8	37.7	77.6	0.50	32.2
3. Reactor Building 200' Elevation	40.2	98.3	100.0	6.34	83.9
<u>II-Set</u>					
4. Reactor Building Dry well 125' Elevation	3.7	74.0	73.30	Not analysed	
5. Reactor Building top 200' Elevation	90.4	97.8	94.9	Not analysed	

TABLE 2 Solubility of Particulate Air Activity in Lung Serum Simulant. Air Samples collected in the working Atmospheres of BWR Power Reactor at Tarapur.

Following conclusions can be reached from the present study. (a) The soluble fractions can be different for the same isotope for air samples collected at different locations (b) The  $^{60}\text{Co}$  in reactor building top is much more soluble compared to locations 1 and 2. (c) The  $^{134} + ^{137}\text{Cs}$ , usually considered as a soluble alkali element is soluble upto 50% only, for airborne activity found in locations 1 and 2. (d) The  $^{140}\text{Ba}$ , though expected to behave similar to  $^{90}\text{Sr}$ , is seen to have much lower solubilities (e) such solubility data help in understanding the fast clearance phase of lung deposited radionuclides in the occupational workers.

---

#### 4. ACKNOWLEDGEMENTS

This work was carried out under a partial support from a research contract No. 1449/RB with the International Atomic Energy Agency. Authors are grateful to Mr. S.D. Soman for his interest and encouragement in this work.

#### REFERENCES

- (1) MORROW, P.E., et. al., TASK GROUP ON LUNG DYNAMICS, Health Physics 12: 173 (1966).
- (2) KOTRAPPA, P., et. al., HASL cyclone as an instrument for measuring aerosol parameters for new lung model, Proc. of III Int. Cong. of IRPA, CONF-730907-P2, 1226 (1974).
- (3) MENON, V.B. et.al., Health Physics 28 : 497 (1973)
- (4) KANAPILLY, G.M. et. al., Health Physics 24 : 497 (1973).
- (5) KOTRAPPA, P., et. al., Dose commitment to the lung from inhalation of radiocobalt in power reactor operation, Proc. of III Int. Cong. of IRPA, CONF-730907-P2, 1232 (1974).

ASPECTS DE RADIOPROTECTION LORS DE L'EXPLOITATION ET  
DU DEMANTELEMENT DES INSTALLATIONS UTILISEES LORS DE  
LA PRODUCTION D'ACTINIUM EN PROVENANCE DE RADIUM IRRADIE

J.P. Deworm, G. Dumont, G. Fieuw, J. Marlein  
Centre d'Etude de l'Energie Nucléaire (CEN/SCK)  
Boeretang 200, 2400 Mol, Belgique.

H. Spriet  
BelgoNucléaire Waste, Boeretang 200, 2400 Mol, Belgique.

## 1. INTRODUCTION

1.1. L' $^{227}\text{Ac}$  était obtenu par irradiation dans un flux thermique de 3 à  $4.10^{14} \text{ n.cm}^{-2}.\text{s}^{-1}$  pendant 2 cycles de 21 jours dans le réacteur à Haut flux BR2. Les problèmes de radioprotection lors de l'exploitation étaient liés à la manipulation de quantités importantes d'émetteurs alpha de très haute toxicité. Chaque cycle de traitement consistait dans la séparation d'environ 70 Ci  $^{226}\text{Ra}$ , 40 Ci  $^{227}\text{Ac}$  et 100 Ci  $^{228}\text{Th}$  et dans le conditionnement de deux capsules de 40 à 70 Ci de  $^{226}\text{Ra}$  pour l'irradiation (1,2). Les opérations de *conditionnement* et de *séparation* pour la production d' $^{227}\text{Ac}$  étaient effectuées dans deux boîtes alpha-étanches ( $\alpha_1$  et  $\alpha_2$ ), leur volume était respectivement de 7 et 5  $\text{m}^3$ . Chaque boîte était installée dans une des deux chambres, qui constituaient l'ensemble de la cellule blindée 1000 Ci-MeV. Les boîtes étaient reliées entre-elles par un soufflet rigide à travers un mur de blindage, qui séparait les deux chambres. L'atmosphère des boîtes était purifiée en radon ( $^{220}\text{Rn}$ ,  $^{222}\text{Rn}$ ) par adsorption sur des trappes à charbon actif et refroidies à l'azote liquide. La cellule blindée elle-même était munie d'un système de ventilation pourvu de filtres absolus.

1.2. L'*exploitation* des installations de production se répartissait sur trois périodes :

- la première de 1969 à 1971 lors de la production de 300 Ci d' $^{227}\text{Ac}$  et 750 Ci de  $^{228}\text{Th}$
- une seconde de 1971 à 1972 avec une révision complète des installations. Une fuite importante ( $100 \text{ l.h}^{-1}.\text{m}^3$  par rapport à  $1 \text{ l.h}^{-1}.\text{m}^3$ ) exigeant des réparations. Les améliorations apportées à l'installation diminuaient le rejet par la cheminée de  $2.10^{-5} \text{ Ci.s}^{-1}$  à  $2.10^{-8} \text{ Ci.s}^{-1}$
- une troisième de 1973 à 1974 d'exploitation avec production de 620 Ci d' $^{227}\text{Ac}$ , 1700 Ci de  $^{228}\text{Th}$  et recyclage de 925 Ci de  $^{226}\text{Ra}$ .

## 2. ASPECTS GÉNÉRAUX DU DEMANTELEMENT DE L'INSTALLATION

### 2.1. Principes généraux

La solution admise sur le plan de sécurité était la transformation de la cellule blindée dans une zone de travail alpha, permettant l'intervention en scaphandre. Dans cette zone étaient exécutés le démontage préalable, la réduction des tôles par découpage au chalumeau plasma et le conditionnement final par enrobage des déchets dans du béton dans des fûts de 400 l.

Avant tout démontage, lorsque l'installation possédait encore ses protections et son équipement complet il avait été procédé aux travaux d'évacuation du petit matériel, de la décontamination de l'intérieur des boîtes (facteur de réduction moyen 10) et aux contrôles de la contamination résiduelle et du taux de rayonnement.

## 2.2. Méthodes et organisation du travail

### 2.2.1. Découpage par chalumeau plasma

Le découpage de la tôle des boîtes à l'aide d'un chalumeau plasma était retenu ; en effet la vitesse importante de découpe permettait de diminuer le temps d'exposition des scaphandriers.

La fumée provenant de la torche exigeait un changement du régime de ventilation (de 24 renouvellements par heure à 88). La fumée, formée de particules dont 88 % avaient un diamètre moyen pondérable inférieur à 1,5  $\mu\text{m}$ , nécessitait une protection des filtres absolus par un préfiltre amovible. Des incendies limités, dus à l'inflammation de la paraffine, employée pour l'isolation des conducteurs électriques à l'intérieur des boîtes, étaient éteints au moyen d'extincteurs portatifs à neige carbonique.

### 2.2.2. Équipement et sécurité des scaphandriers

Les techniques employées et une planification des opérations avaient permis de réduire au maximum l'exposition externe et interne des scaphandriers.

#### 2.2.2.1. Les techniques employées :

- Le scaphandre utilisé était composé d'une combinaison de vinyle autoextinguible d'une seule pièce et non récupérable. Il était alimenté en air comprimé et filtré.
- Lors de l'emploi de la torche plasma un poncho en amiante ou en coton incombustible protégeait le scaphandre.
- L'exposition externe était déterminée par dosimétrie (Dil, film, stylos dosimètres). Chaque scaphandrier était muni de deux ensembles de dosimètres, l'un à l'intérieur et l'autre à l'extérieur du scaphandre. La règle générale consistait à limiter la dose corporelle inférieure à 2000 mrem.
- L'exposition interne était contrôlée par une mesure du mucus nasal après chaque intervention. Lors d'un dépassement ou niveau d'investigation (1000 dpm en  $\alpha$ ), des prélèvements biologiques étaient effectués. Chaque scaphandrier subit une mesure de la contamination au niveau des poumons.
- La teneur en radon de l'atmosphère des différentes parties de l'installation était contrôlée par un système de moniteurs (1).

#### 2.2.2.2. La planification :

- La durée de chaque tâche était de l'ordre de 10 à 20 minutes en fonction du taux de rayonnement. Chaque entrée de scaphandriers était précédée d'une instruction à l'aide de photos détaillées.

- Chaque tâche était exécutée pour des raisons de sécurité par deux personnes.
- Les travaux étaient guidés de l'extérieur par un opérateur qui suivait le travail en cours à travers une baie vitrée. Cet opérateur était en liaison permanente par interphone avec les scaphandriers.

### 3. CONCLUSIONS

Aucun incident n'était noté durant le démantèlement des deux boîtes alpha. La durée des opérations était respectivement 150 h pour  $\alpha_1$  et 120 h pour  $\alpha_2$ .

Doses en mrem inférieures à	Cumulatif en %		Analyse musc. nasal inférieure à	Cumulatif en %	
	$\alpha_1$	$\alpha_2$		$\alpha_1$	$\alpha_2$
500	22	19	10 dpm	34	57
1000	45	44	20 dpm	55	74
1500	71	77	50 dpm	73	85
2000	89,8	100	100 dpm	84	91
			500 dpm	84	98
			1000 dpm	3	1
Dose moyenne mrem	1080	1050	maximum dpm	10.000	1280
Dose maximum	2100	1960			
Dose totale en hommes-mrem	94	45	nombre total d'analyses	185	104
Nombre de personnes	58	42			

TABLEAU 1 Doses corporelles et contamination du personnel d'intervention.

Le tableau 1 indique la distribution des doses corporelles reçues par le personnel qui avait travaillé dans des champs de rayonnement variant entre 0,3 et 3 R.h<sup>-1</sup>, avec un maximum de 100 R.h<sup>-1</sup>.

Seulement 3 et 1 % des analyses du mucus nasal étaient supérieures à 1000 dpm. Aucune contamination interne n'était décelée ni par les analyses des prélèvements biologiques ni par la mesure de la contamination au niveau des poumons.

Nous reterons particulièrement la souplesse obtenue par l'emploi de la torche plasma lors du démantèlement de ces installations contaminées par des radio-éléments très radiotoxiques sous un champ de rayonnement important.

#### REFERENCES

- (1) J.P. CLWORM, G. FIELOW "Problèmes de radioprotection posés lors de la production de quantités importantes d' $^{227}\text{Ac}$ ." VI<sup>e</sup> Congrès international de la Société Française de radioprotection Bordeaux 27-30 mars 1972 p. 109
- (2) L.H. BAFISLE, A.C. DEMILDI, D. HUYS, A. DRICISSART, J. ROOSE  
Gram scale production of  $^{227}\text{Ac}$  from irradiated radium.  
Deuxième symposium international sur l'énergie d'origine radio-isotopique OCDF Madrid 29/5 - 1/6/1972. Compte rendu p. 95.

## LE DECLASSERMENT DES INSTALLATIONS NUCLEAIRES

par : A. CREGUT - C.E.A./IPSN  
M. JACQUEMIN - C.E.A./IPSN

## 1. NIVEAUX DE DECLASSERMENT

Il est entendu que le déclassement implique l'arrêt définitif de l'installation et change la situation juridique.

Le combustible, ou la matière radioactive traitée, ainsi que les déchets produits en exploitation courante ont été au préalable enlevés par les moyens habituels de l'installation.

On distingue trois stades de déclassement, caractérisés chacun par deux paramètres a) l'état physique de l'installation ; b) la surveillance nécessaire.

## Niveau 1 : fermeture sous surveillance

- a) l'installation est décontaminée, mais n'est pas modifiée ; l'atmosphère reste conditionnée par une ventilation appropriée.
- b) l'accès dans le bâtiment est limité et contrôlé ; une surveillance de la radioactivité à l'intérieur et à l'extérieur est assurée, des inspections périodiques sont effectuées pour vérifier la bonne conservation de l'installation ; l'étanchéité du confinement est contrôlée périodiquement.

## Niveau 2 : libération partielle et conditionnelle de l'emplacement

- a) le confinement primaire est ramené au volume minimal et son étanchéité est renforcée par des moyens mécaniques. La protection biologique est prolongée pour entourer entièrement la première barrière, toutes les parties démontables sont enlevées et peuvent être stockées à l'intérieur du confinement primaire. Le bâtiment étanche et sa ventilation peuvent être modifiés en vue d'une autre utilisation.
- b) la surveillance se réduit à des contrôles localisés et espacés, et à des inspections externes du confinement. L'installation reste sur un site nucléaire ; sa nouvelle utilisation est soumise aux règles d'accès et de travail en vigueur sur le site.

## Niveau 3 : libération totale et inconditionnelle

- a) tous les matériaux dont l'activité résiduelle dépasse les limites admissibles pour un libre usage sont enlevés.
- b) aucune surveillance n'est plus exercée. L'emplacement peut ne plus être site nucléaire.

Le choix du niveau de déclassement peut être déterminé par des considérations économiques, par les exigences des autorités, par la pression du public, par le besoin de récupérer totalement l'emplacement ou de le céder à un tiers pour un usage non nucléaire.



Il n'est pas obligatoire, pour arriver au niveau 3, de passer successivement par les deux premiers. Mais, notamment dans le cas des réacteurs, il sera en fait utile de passer par le niveau 1 et d'y rester un temps suffisant pour permettre la décroissance de l'activité résiduelle et faciliter ainsi le passage au niveau 3.

## 2. LE DECLASSEMENT ET SA MISE EN OEUVRE : EQUIPEMENTS ET TECHNIQUES CONCERNES.

Lorsque le niveau choisi pour le déclassement d'une installation conduit à son démontage et à son démantèlement, les travaux à réaliser ne sont pas fondamentalement différents de ceux qui couvrent les opérations d'entretien ou d'intervention. Toutefois, les difficultés sont accrues par la présence :

- de pièces très lourdes à décontaminer, démonter, découper et manutentionner en actif (4 à 500 tonnes pour une cuve de PWR par exemple).
- de très grandes quantités de matériaux actifs et contaminés à conditionner, transporter et stocker (3 à 5000 tonnes de graphite, 100 à 1500 tonnes d'acier de structure, 2000 à 18000 m<sup>3</sup> de béton).
- de quantités importantes d'effluents à traiter et à évacuer.

Les opérations prennent alors un caractère industriel dont le rendement, la sûreté et la sécurité reposent sur l'existence d'équipements spécialisés et la maîtrise de techniques appropriées.

Les méthodes et techniques connues et les équipements spécialisés nécessaires peuvent se classer comme suit :

### 2.1. Décontamination

- par jets d'eau haute pression et faible débit.
- par procédés chimiques.
- par meulage, rabotage et sablage.

### 2.2. Découpage

- à l'arc.
- au plasma.
- à l'explosif par charge creuse.
- au marteau piqueur.
- à la perforatrice.
- à la lance thermique.
- mécanique (scie, cisaille et vérin).
- au laser.

### 2.3. Démontage à distance

- par télémanipulateur.
- par téléopérateur.

### 2.4. Manutention à distance

- par engins télécommandés.

### 2.5. Conditionnement pour transport et stockage

- traitement de fixation, de contamination.
- réduction de volume (compactage par presse, compacteur etc...).
- conditionnement des matériaux (résine, bitume, béton etc...).

### 2.6. Transport

- par hotte de manutention.
- par château de transport.
- par véhicule spécialisé.

### 2.7. Traitement des effluents et déchets

- par les procédés déjà connus.
- par des procédés particuliers pour certains matériaux (brûlage du graphite, épuration du sodium etc...).

### 2.8. Stockage particulier

- béton activé par exemple.

### 2.9. Protection

- cabine blindée "déplaçable".
- bouclier biologique standard "déplaçable".
- installation transportable telle que sas personnel.
- cabine de décontamination, etc...

## 3. EXPERIENCE EN FRANCE

Le nombre des installations mises à l'arrêt définitif en France est relativement restreint. Toutefois, la diversité des unités concernées et les études et travaux qui ont été réalisés à l'occasion de ces arrêts ont apporté une contribution significative à la connaissance des problèmes liés au déclassement et ont souligné quelques unes des difficultés à surmonter.

Les installations qui ont été traitées sont :

- pour les réacteurs de puissance  
G1 et EdF 1 de la filière UNGG.
- pour les réacteurs d'expérimentation  
Pégase, Peggy et Minerve du type piscine  
Zoë, Et2 du type D20

- pour les usines
  - le pilote d'extraction du plutonium du Centre de Fontenay-aux-Roses.
  - l'extraction d'uranium du Centre du Bouchet.
- pour les cellules
  - Attila (unité pilote de retraitement du combustible par voie sèche).
  - Elan II B (unité de fabrication de sources de strontium).

La situation de ces installations en prenant comme base de référence les niveaux de déclassement tels que définis par l'Agence Internationale de l'Energie Atomique est à ce jour la suivante :

- au niveau 1 : G1, EdF 1, Pégase (1), Attila (1), et Elan II B (1).
- au niveau 2 : EL2.
- au niveau 3 : Peggy, Minerve (en cours de réinstallation sur le Centre de Cadarache).
  - l'usine pilote d'extraction du plutonium de Fontenay-aux-Roses.
  - l'usine d'extraction d'uranium du Bouchet.

En fonction des installations considérées, on peut d'ores et déjà tirer les enseignements suivants :

- pour les réacteurs de puissance :
  - la possibilité du démantèlement total existe malgré les difficultés liées à la très grande quantité de matériaux actifs et contaminés qui sont mis en oeuvre. Il semble toutefois nécessaire d'améliorer les équipements de découpage et manutention aussi bien pour les aciers de fortes épaisseurs que pour les bétons de protection biologique.
  - Il faut en outre s'attacher à réduire les quantités de déchets en développant des procédés tels que l'incinération du graphite pour les réacteurs de la filière UNGG.
- pour les usines et cellules, deux problèmes délicats sont à souligner :
  - la récupération des émetteurs alpha au cours des décontaminations et le stockage des déchets produits.
  - On peut noter la solution originale du retour à la mine d'origine d'une très grande quantité des déchets de très faible activité provenant de l'usine du Bouchet.
  - Il faut aussi évoquer les études de principe sur la faisabilité du déclassement aux divers niveaux d'un PWR de 1200 MWe qui ont permis d'estimer le coût probable de chacune de ces solutions.

(1) On étudie actuellement les possibilités de reconversion de ces installations.

MEASUREMENT of ENVIRONMENTAL  $\gamma$ -RADIATION and  
ESTIMATION of DOSE EQUIVALENT RATE

I. Urabe, T. Tsujimoto, K. Yamasaki, T. Yoshimoto, K. Okamoto, and K. Katsurayama  
Research Reactor Institute, Kyoto University  
Kumatori-Cho, Sennan-Gun, Osaka, Japan

N. Itakura, Y. Nakashima  
Faculty of Engineering, Nagoya University  
Furo-Cho, Chikusa-Ku, Nagoya, Japan

## 1. INTRODUCTION

From the view point of health physics, it is the important problems to determine the  $\gamma$ -radiation energy spectra and to estimate the absorbed doses in organs. Though many investigations on the terrestrial  $\gamma$ -radiation and on the absorbed dose in several organs have been made, only a little have been reported on the dose equivalent rate caused terrestrial  $\gamma$ -radiation, and almost of these researches have been obtained being calculated numerically. To estimate dose equivalent rates in human organs placed in natural environment, true energy spectra of the radiation with energy up to 3 MeV at the place of interest must be evaluated. In the various unfolding techniques of pulse-height distributions obtained NaI(Tl) scintillation detector, true energy spectra of  $\gamma$ -radiation could be estimated by the iterative technique using the response matrix. The present paper includes a evaluation of true photon energy spectra due to environmental  $\gamma$ -radiation, and an estimation of dose equivalent rates in testes, ovaries, and bone marrow in some radiation fields after Jones' results.

## 2. EXPERIMENTAL

### 2.1. Measurements

Pulse-height distributions were measured in some environments by using a scintillation spectrometer with  $3''\phi$ spherical NaI(Tl) crystal encapsuled in almiruc with 0.8 mm thick. Measurements were carried out in the field and in the laboratory at Research Reactor Institute of Kyoto University. The detector was placed at one meter from the ground surface in the field, or from the floor in the laboratory whose wall was made of concrete. A pulse-height analyzer recorded pulses due to  $\gamma$ -radiation of the energy range between 0 and 3 MeV, which covered the entire range of the terrestrial  $\gamma$ -radiation.

Pulse-height distributions observed using a NaI(Tl) scintillation spectrometer do not generally show the true photon energy spectra incident on a detector, because of complex interactions in a NaI(Tl) detector even for mono-energetic photons. To obtain the true energy spectra, pulse-height distributions must be unfolded by using the response function or the response matrix of the whole measuring system. The pulse-height distributions were divided into 34 histograms, whose energy division was chosen as 0.02 MeV obtained between 0 and 0.1 MeV and as 0.1 MeV above 0.1 MeV. The 34 x 34 response matrix of the system was used to unfold observed pulse-height distributions into the true energy spectra by using iterative technique. Exposure rates can be evaluated on the basis of the true photon energy spectra.

### 2.2. Dose Equivalent Rate

After the exposure rates caused by environmental  $\gamma$ -radiation were obtained,

absorbed dose in each organ have been determined by using the relation between absorbed dose in each organ evaluated with the aid of a realistic phantom and that in air (exposure) at the point of interest. Some experiments and calculations have been made to determine the relation between absorbed dose rates and exposure rates. Experimental measurements of organ absorbed dose rates have been reported by Jones, who used a human phantom consisting of tissue-like materials and bones. Rad/roentgen conversion factors were reported in his study for 11 photon energies ranging up to 1.25 MeV. His measurements, however, were not involved the energy above 1.25 MeV. Therefore, Jones' results were extrapolated up to 3 MeV, taking into consideration of other studies, in order to include the entire energy range of environmental photons. After the determination of the relation between absorbed dose rates in testes, ovaries, and bone marrow and exposure rates for wide energy range, absorbed dose rates were obtained for each organ of human body of interest. The procedure includes the determination of absorbed doses for each energy width in the spectra obtained in the environments using rad/roentgen conversion factors as above mentioned, and summing up these absorbed doses obtained. Since quality factor (QF) for electrons originating from photon irradiation is chosen as one, a dose equivalent can be referred to an absorbed dose rate derived here.

### 3. RESULTS and DISCUSSION

#### 3.1. Observed Pulse-height Distributions and True Photon Spectra

Typical pulse-height distributions observed in the field and in the laboratory were shown in Fig. 1. As is evident from the figure, clear difference was found between the two. The peak at about 0.66 MeV in the field was considered due to cesium-137, one of the fallout nuclides. On the other hand, the result obtained in the laboratory showed a little weak intensity below 0.2 MeV. Pulse-height distributions obtained in the field and in the laboratory were analyzed with the aid of response matrix. The results were shown in Fig. 2. As can be seen from the figure, the true spectra consist of components due to primary  $\gamma$ -radiation and scattered ones from both natural occurring and fallout radionuclides.

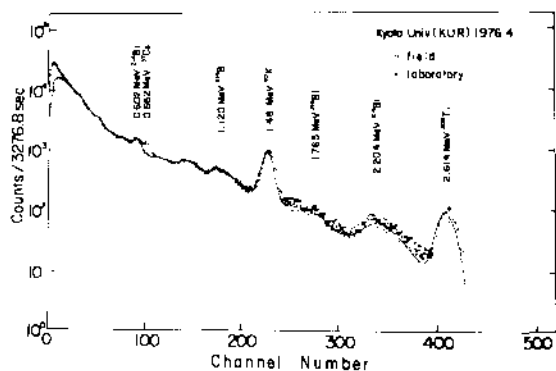

Fig. 1. Observed Pulse-height Distributions

#### 3.2. Exposure Rates and Dose Equivalent Rates

Exposure rates due to the environmental  $\gamma$ -radiation were obtained on the basis of the true spectra. These results were shown in Fig. 3. Exposure rates obtained in the field and in the laboratory were 5.5 and 4.5  $\mu$ R/h, respectively. One of main causes of the above difference seems to be due to absorption or scattering of the terrestrial  $\gamma$ -radiation by the building.

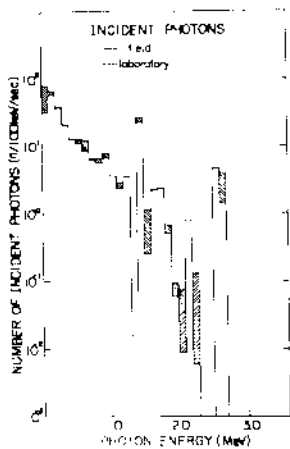

Fig. 2. Energy Spectra of Incident Photons.

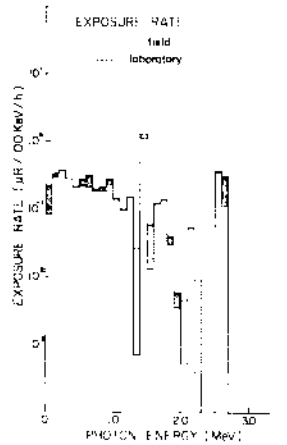

Fig. 3. Energy Spectra of Exposure Rate.

Generally speaking, there were much photons arising from potassium-40 contained in the concrete floor and wall in the laboratory than in the field covered with lawn. But the results obtained here were contrary to this expectation. This seems to be owing to potassium amounted artificially to grow the lawn. Another cause was due to shielding of  $\gamma$ -radiation arising from the fallout radionuclides. Exposure rate due to cesium-137 was roughly estimated with the aid of these results obtained here, and found to be 0.1-0.2  $\mu$ R/h.

Dose equivalent rates in testes, ovaries, and bone marrow determined from the exposure rates as a function of photon energy were shown in Figs. 4, 5, and 6.

Dose equivalent rates in each organ obtained in the field were 4.0, 3.5, 4.3, and in the Laboratory 3.4, 3.0, 3.7  $\mu$ rem/h, respectively. And the ratio of rem/roentgen in each organ could be determined to be 0.73, 0.64, 0.78, and 0.74, 0.65, 0.80, respectively. The ratios of rem/roentgen at various field did not change remarkably in spite of the difference appeared in the spectra. In many studies on human exposure, a few have mentioned absorbed dose in human organs in relation to environmental  $\gamma$ -radiation. Investigations on absorbed doses in relation to environmental  $\gamma$ -radiation field have been made by Bennet, and O'Brien. Bennet have estimated absorbed doses after obtaining the depth-dose distributions around the body resulting from the uniform distributions of uranium-238 series, thorium-232 series, potassium-40, and the plane and exponential distributions of cesium-137 in the soil. Bennet's results were different



Fig. 4. Energy Spectra of Dose Equivalent Rate in Testes.

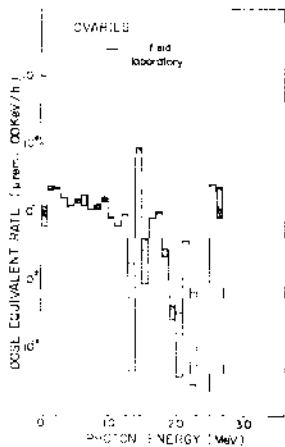

Fig. 5. Energy Spectra of Dose Equivalent Rate in Ovaries.

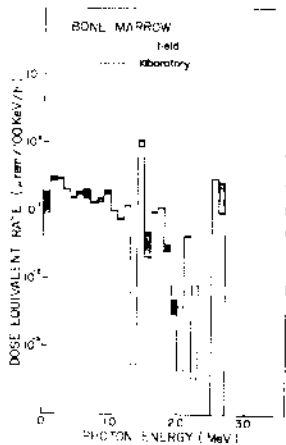

Fig. 6. Energy Spectra of Dose Equivalent Rate in Bone Marrow.

slightly from the results obtained in the present study for the ratios rem/roentgen. Main sources of the differences might be in way of evaluation of  $\gamma$ -ray field and in extrapolation of rad/roentgen conversion factor above 1.25 MeV. The calculation obtained with the aid of 3-dimensional Monte Carlo code have reported by O'Brien. The dose to each of 34 organs and groups of organs irradiated isotropically with mono-energetic photons from 0.02 MeV to 10 MeV were calculated. O'Brien's results were lower than those of Jones, Bennet, and the present study. Further studies will be necessary for discussion on the difference in the conversion factors. To estimate the gonadal dose, the rad/roentgen conversion factor was recommended by the UNSCEAR as 0.6. However, the present results show slightly higher compared with that.

#### CONCLUSION

Energy spectra caused by  $\gamma$ -radiation were obtained in the natural environments and in the laboratory. Dose equivalent rates in testes, ovaries, and bone marrow were estimated in the field and in the laboratory, respectively. Though the conversion factors obtained here were slightly larger compared with that of UNSCEAR, unique conversion factor rem/roentgen in each organ may be used to obtain the dose equivalent rates in testes, ovaries, and bone marrow after measurements of absorbed dose in air.

#### REFERENCES

- (1) BECK, H.U., et al., U.S.At.Energy Comr.Rep. HASL-150.
- (2) MINATO, S., KAWANO, M., J.Geophys.Res. 7 (1970) 5825.
- (3) JONES, A.R., Health Phys. 12 (1966) 663.
- (4) BENNET, B.G., Health Phys. 19 (1970) 757.
- (5) O'BRIEN, K., SANNA, R.S., Health Phys. 30 (1976) 71

IN SITU MEASUREMENTS WITH A Ge(Li)-SPECTROMETER  
AROUND A NUCLEAR POWER STATION.

R.R. Finck, K. Lidén and R.B.R. Persson

Department of Radiation Physics, University of Lund,  
Lund, Sweden

### 1. INTRODUCTION

The development of large Ge(Li)-detectors with high energy resolution has not only made it possible to measure small amounts of artificial radionuclides in the natural radiation background but also offered a possibility to record very low exposure levels. Already in 1972 we started to build a mobile laboratory for Ge(Li)-spectrometry measurements in the field. This equipment was devoted to studies of the influence of nuclear power plants on the radiation field in their environment (1). Barsebäck Nuclear Power Station is situated about 17 km from Lund. This is a convenient distance for regular excursions from our Institute at the University. A network of measuring points was set up before the first reactor was started and the background levels were studied very carefully. After reactor startup in 1975 measurements have been performed at various distances from the reactor and at various occasions.

### 2. EQUIPMENT

Fig 1 shows the closed end coaxially drifted Ge(Li)-detector mounted on a tripod. The detector is set vertically beneath the cryostat in order to minimize shielding of the primary radiation field from ground deposited radionuclides. The preamplifier power is derived from NiCd-batteries with 8 h capacity. They are, however, normally charged from the generator. High voltage for the detector bias is obtained from an incapsulated battery package. As soon as the pulse height distribution is recorded in the analyzer core memory a preliminary evaluation is performed. Normally the data is transferred to paper tape for computer analysis at the laboratory in Lund. It is thus possible to calculate the amount of radionuclides deposited on ground in  $\text{Bq/m}^2$  ( $\text{nCi/m}^2$ ); and also to calculate the exposure contribution from each radionuclide in  $\mu\text{R/h}$  or absorbed dose rate in air  $\mu\text{Gy/s}$  ( $\mu\text{rad/h}$ ).

### 3. MEASUREMENTS

The background radiation field in the vicinity of Barsebäck Nuclear Power Plant was studied in 1974 when the plant was under construction. The reactor was started in January, 1975. No significant influence from the reactor operations was observed in measurements of ground activity concentrations carried out since the startup. Table 1 shows the results from measurements on a grass-covered area bordering the reactor fence line. The activity concentration of I-131 has been less than  $7 \text{ Bq/m}^2$  ( $0.2 \text{ nCi/m}^2$ ) until October, 1976.



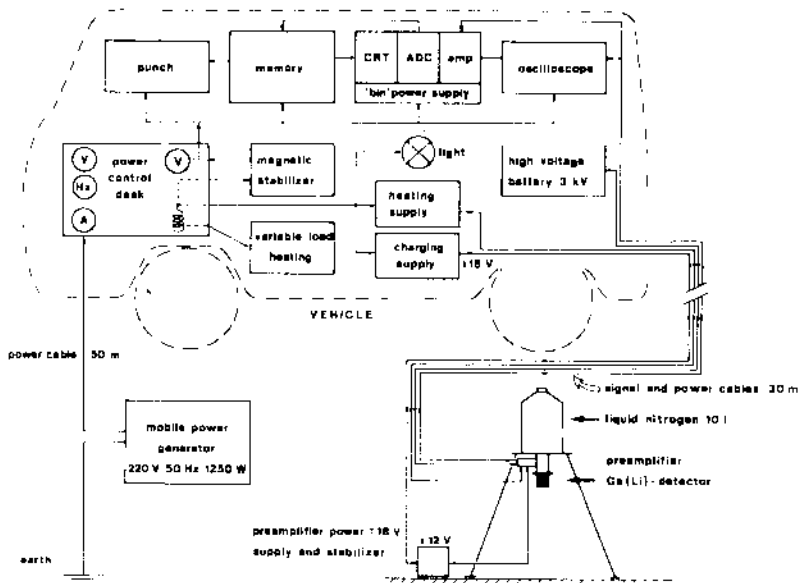

Fig 1. System diagram of field Ge(Li) gamma spectrometric equipment.

Year of measurement	Activity concentration, Bq/kg				
	238 U	232 Th	40 K	137 Cs	
1974	14 <sup>+</sup> <sub>-1</sub>	17 <sup>+</sup> <sub>-1</sub>	555 <sup>+</sup> <sub>-7</sub>	5.9 <sup>+</sup> <sub>-0.4</sub>	
1975	14 <sup>+</sup> <sub>-1</sub>	17 <sup>+</sup> <sub>-1</sub>	551 <sup>+</sup> <sub>-7</sub>	5.9 <sup>+</sup> <sub>-0.4</sub>	
1976	13 <sup>+</sup> <sub>-2</sub>	14 <sup>+</sup> <sub>-2</sub>	518 <sup>+</sup> <sub>-15</sub>	5.2 <sup>+</sup> <sub>-0.7</sub>	

TABLE 1 Activity concentrations in soil under a grass-covered area just outside the fence line of Barsebäck Nuclear Power Plant. The activity concentrations, including overall uncertainty limits, are given in Bq/kg (1 Bq = 0.027 nCi).

### 3.1 Fall-out Measurements

In measurements performed during the period October, 22 - November, 2 1976 fresh fission products were recorded at places in the vicinity of Barsebäck, Lund and Ljungbyhed (42 km north of Lund). The variation in surface area concentration of these fission products at the three places was very small. We therefore believe that they are originating from a Chinese nuclear explosion in the atmosphere of September, 26 1976. Fig 2 shows a pulse height distribution recorded in situ 1 m above ground at Barsebäck. Peaks in count rate due to natural radionuclides are indicated at the top of the figure and at the bottom are shown the fission products. Table 2 gives the area concentration of the main fission products recorded.

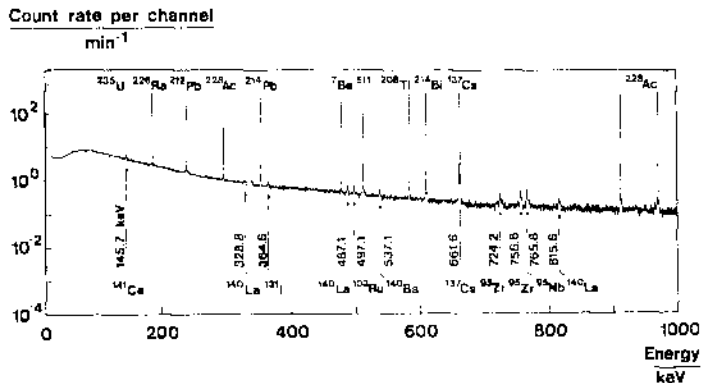

Fig 2. *In situ* pulse height distribution recorded at Barsebäck on 28 October 1976 with the Ge(Li) detector 1 m above ground. Counting time = 5 h.

	Bq/m <sup>2</sup>	nCi/m <sup>2</sup>
Ce-141	140 ± 20	3,7 ± 0,5
I-131	41 ± 7	1,1 ± 0,2
La-140	130 ± 15	3,5 ± 0,4
Ru-103	44 ± 7	1,2 ± 0,2
Zr-95	96 ± 20	2,6 ± 0,5
Nb-95	48 ± 10	1,3 ± 0,3

TABLE 2 Surface activity concentrations in Barsebäck 29 October 1976.

### 3.2 Radiation Field Measurements

Due to our carefully performed background studies before reactor startup we have been able to record an additional photon fluence near the power plant. A significant increase was detected in the 511 keV peak at 250 m from the reactor which was proportional to the power output of the generator. Further measurements revealed that this is due to N-16 ( $T_{1/2} = 7.2$  s) and C-15 ( $T_{1/2} = 2.45$  s) which are produced in the reactor water by the (n,p) and (n, $\alpha$ ) reactions on C-16 and O-18 respectively. Scattered radiation from the high energy gamma rays of 5 - 7 MeV, produced in the decay of these radionuclides contributes significantly to the environmental radiation in the neighbourhood of a power station (2).

### 3.3 Measurements of Xe-133 Release

We have also recorded a test release of Xe-133 from the Barsebäck II reactor. The detector was placed at ground level in the direction of wind 200 m from the base of the 110 m release stack. A total activity of 260 GBq (7 Ci) was released through the stack during a time interval of 4.5 min. The detector recorded the full energy absorption peak at 81 keV and a large continuum of scattered radiation below this energy. From the measurements it was possible to estimate the minimum detectable release rate for Xe-133.

The minimum detectable release rates for Xe-133 at 110 m and wind speed of 6 m/s (lofting plume) are estimated to be about 30 MBq/s (0.8 mCi/s) assuming a continuous release for a period of 1 hour and 10 MBq/s (0.3 mCi/s) during 6 hours release time. These values, however, depend directly on wind speed and are also sensitive to the shape and movement of the plume. The minimum detectable activity rates correspond to exposure rates at the detector of 0.05  $\mu$ R/h and 0.02  $\mu$ R/h respectively.

At this short distance from the release stack the geometry of the plume normally is quite simple and the distance to the ground is approximately equal to the stack height. At greater distances from the stack the shape and height of the plume depend very much on weather conditions and thus complicate the calculations of plume activity concentration. But a possibility exists to estimate an approximate effective distance to the plume from the ratio of count rate obtained in the full energy peak from primary photons to the count rate in the low energy continuum obtained from air-scattered photons. Normally, however, estimation of exposure rate at ground level is of the main interest. The direct calculation of exposure rates is done from measurements of primary and scattered radiation at the detector. This can be made more accurate than the activity calculations of the plume since no knowledge of source-detector distance is necessary in converting the pulse height distribution to exposure rate.

#### REFERENCES

- (1) FINCK R.R., LIDEN K., PERSSON R.B.R.  
In Situ Measurements of Environmental Gamma Radiation by the use of a Ge(Li)-spectrometer.  
Nucl. Instr. Meth. 135 (1976) 559
- (2) LOWDER W.M., RAFT P.D., de PLANQUE BURKE G.  
Determination of N-16 Gamma Radiation Fields at BWR Nuclear Power Stations.  
Report HASL-305 (1976)

MEASUREMENTS OF NATURAL RADIOACTIVITY AND EMANATION POWER OF  
COAL-FUELED POWER PLANT WASTES USED IN BUILDING INDUSTRY

Jerzy Pensko and Zofia Stpiczynska  
Institute of Nuclear Research, 05-400 Swierk-Otwock, Poland

## 1. INTRODUCTION

Fly-ash and slag, the waste products of fossil-fueled power plants, are valuable raw materials for making concrete and sintered fine aggregate which are used for house constructing. Such materials among other trace elements contain uranium and thorium with their daughter products, as well as potassium-40 which are main radioactive components of these wastes. Therefore, the radioactivity control of fly-ash and slag should make the main point of utilizing these wastes in building industry. Such control is necessary for the estimation and control of future population exposure level. In addition to cosmic-rays there are two main sources of human radiation exposure indoors: gamma-ray external whole body irradiation originating from the walls and lung tissues exposure by alpha-rays emitted by radon daughters present in the inhaled air. Thus, for proper estimation of this kind of radiation hazard to the population two kinds of information are required: the knowledge of the concentration of main natural gamma-ray emitters in coal-fueled power plant wastes and the values of the radon emanation power from fly-ash and slag samples.

## 2. METHODS

Natural radionuclides present in coal fuel are in radioactive equilibrium but during the combustion of coal and flotation processes of wastes some radionuclides can be eliminated from the ash or slag thus causing some disturbances in equilibrium conditions. It is however not difficult to prove that the practical radioactive equilibrium within radionuclides from  $^{226}\text{Ra}$  to  $^{210}\text{Pb}$  and from  $^{228}\text{Th}$  to  $^{208}\text{Tl}$  respectively is established approx. 1 month after the formation of coal-fueled power plant wastes. As the contribution of all precursors of  $^{226}\text{Ra}$  and  $^{228}\text{Th}$  in the indoor gamma radiation field and whole body dose is negligible the main attention was paid to  $^{214}\text{Bi}$  and  $^{208}\text{Tl}$  which emit high energy gamma radiation of 1.764 MeV and 2.614 MeV, respectively. These radionuclides also determine the concentrations of  $^{226}\text{Ra}$  and  $^{228}\text{Th}$  in the samples investigated and are easily measured with a 3-chan-

nel scintillation gamma-ray spectrometer.

For calibration of the spectrometer 3 kinds of standard sources were prepared:  $^{40}\text{K}$  standard was made using KCl pure p.a. the activity of which was estimated from literature data (1),  $^{214}\text{Bi}$  standard was prepared using the uranium ore in which the concentration of  $\text{U}_3\text{O}_8$  in equilibrium with daughters was estimated to be  $0.471 \pm 0.002\%$  and  $^{208}\text{Tl}$  standard was made using the  $\text{ThO}_3$  pure p.a. in which the  $^{208}\text{Tl}$  activity was experimentally estimated to be  $0.0967 \pm 0.0004 / \mu\text{Ci g}^{-1}$ . The standard sources were spread uniformly in  $\text{SiO}_2$  pure p.a., the volume of which was  $2000 \text{ cm}^3$ . The same volume of all samples was kept during the measurements. The concentrations /in  $\mu\text{Ci g}^{-1}$ / of  $^{40}\text{K}$ ,  $^{214}\text{Bi}$  and  $^{208}\text{Tl}$  in the samples under investigation were determined using the following equations:

$$A_K = 52.31 \frac{N_K}{m_p} \exp[-a/m_p - m_w]$$

$$A_{Bi} = 20.72 \frac{N_{Bi}}{m_p} \exp[-a/m_p - m_w] \quad /1/$$

$$A_{Tl} = 4.65 \frac{N_{Tl}}{m_p} \exp[-a/m_p - m_w]$$

where  $N_K, N_{Bi}, N_{Tl}$  are the counting rates estimated for  $^{40}\text{K}$ ,  $^{214}\text{Bi}$  and  $^{208}\text{Tl}$  gamma-ray total absorption peaks / $10^{-3}$  cps/,  $m_p$  is the mass of sample /g/,  $m_w$  is the mass of standard /g/ a is an experimentally determined factor for the correction of the self-absorption effect / $a = 2.7 \cdot 10^{-6} \text{ g}^{-1} \pm 2.6\%$ ./

The numerical coefficients in equations /1/ represent the calibration factors and are expressed in  $10^3 \text{ pCi/cps}$ . The sensitivity of the method was determined to be

$$A_K = 1.7 \text{ pCi g}^{-1} \pm 23\%$$

$$A_{Bi} = 0.5 \text{ pCi g}^{-1} \pm 17\%$$

$$A_{Tl} = 0.09 \text{ pCi g}^{-1} \pm 12\%$$

These values were obtained for /2/ the sample and background measuring times equal to  $5 \cdot 10^4 \text{ s}$ .

In coal-fueled power plant wastes  $^{222}\text{Rn}$  is present in the form of a noble gas which could migrate through these porous media to the atmosphere. For the estimation of the emanation coefficient, which is defined as the ratio of migrating  $^{222}\text{Rn}$  to the  $^{226}\text{Ra}$  content in the sample, the material investigated was placed in an air-tight glass container 22 cm in diameter and  $6000 \text{ cm}^3$  in volume. Radon diffusing from the sample into the air inside the container become uniformly distributed in the air volume through the gap in the doubly ground glass plate which divided the container in two parts. The application of a doubly ground glass plate made it possible to separate air-radon from the sample-radon while transferring the air sample into the measuring chamber by vacuum technic.

The emanation coefficients were estimated for thick samples the optimal thickness of which was found to be approx. 9 cm. This was assessed by estimating the diffusion factor which for the power plant fly-ashes amounted to  $8.5 \cdot 10^{-6} \text{ cm}^2 \text{ s}^{-1}$ . The estimated diffusion factor proved to be very small compared for example with the soil for which it was found to be approx.  $5 \cdot 10^{-2} \text{ cm}^2 \text{ s}^{-1}$  (2). All fly-ash and slag samples were dried at  $105^\circ\text{C}$  before placing inside the container and air-radon samples were measured after 4 days. Radon was measured in an electrostatically operated cylindrical steel chamber /3000  $\text{cm}^3$ / in which alpha-ray scintillations were counted by a photomultiplier and typical electronic equipment(3). The sensitivity of our new radon measuring system was  $50 \text{ pCi m}^{-3}$  and this figure could be lowered if necessary being about two orders of magnitude greater than that for typical measurements. The calibration factor estimated by means of a standard radium solution was found to be  $1.8 \cdot 10^{-2} \text{ cps/pCi}$ .

### 3. RESULTS

The application of the above methods permitted the determination of radiological parameters of coal-fueled power plant wastes. All ash samples were taken from each funnel of electro-filters 6 times daily during the optimal load of an electric generator. Slag samples were taken similarly from the slag tank. The radioactivity was estimated separately for averaged samples taken from each of 3 areas of fly/ash fall. The measurement results of sporadically taken samples from 10 big coal-fueled power plants are shown in Table 1. Table 2 presents condensed results obtained for one big coal-fueled power plant from which 108 waste samples were taken systematically during the whole year 1976. In the table the results of air absorbed dose rate computations for various geometrical conditions of irradiation were also included.

The distribution of natural radionuclide concentrations in fly-ash and slag samples taken from 10 big coal-fueled power plants under investigation shows that the radioactive properties of these wastes depend mainly on the class of the coal burned /Tab.1/ and on the combustion processes. Very small fluctuations in the radioactivity concentrations in the wastes originated from the same power plant investigated during the whole year /Tab.2/ confirmed this conclusion. The emanation power of fly-ash and slag samples is very low and nearly identical for both materials. The emanation coefficient does not exceed in this case 1.6%. From

Table 2 it can be seen that the highest contribution in the indoors gamma-ray field have short-lived decay products of  $^{226}\text{Ra}$ .

	Radio-nuclide	Concentration, pCi/g		Emanation Coefficient, %	
		Range	Mean	Range	Mean
FLY-ASH	$^{40}\text{K}$	12.4 - 20.6	16.9	0.20 - 1.16	0.54
	$^{214}\text{Bi}$	1.7 - 3.9	2.6		
	$^{208}\text{Tl}$	0.32 - 0.70	0.58		
	$^{222}\text{Rn}$				
SLAG	$^{40}\text{K}$	10.6 - 18.2	13.3	0.24 - 1.53	0.70
	$^{214}\text{Bi}$	1.0 - 3.6	1.8		
	$^{208}\text{Tl}$	0.34 - 0.57	0.46		
	$^{222}\text{Rn}$				

Table 1. Radiological features of grate wastes produced by selected coal-fueled big power plant.

	Radio-nuclide	Concentration, pCi/g		Air dose-rate / $\mu\text{rad}/\text{h}/$ at geometry		
		Range	Mean	$2\pi$	$3\pi$	$4\pi$
FLY-ASH	$^{40}\text{K}$	10.4 - 48.0	22.5	3.6	5.4	7.2
	$^{214}\text{Bi}$	1.9 - 16.5	6.4	10.1	15.1	20.2
	$^{208}\text{Tl}$	0.5 - 2.9	1.1	2.8	4.2	5.6
	All			16.5	24.7	33.0
SLAG	$^{40}\text{K}$	6.1 - 60.2	17.3	2.8	4.2	5.6
	$^{214}\text{Bi}$	0.5 - 12.4	4.3	6.9	10.4	13.8
	$^{208}\text{Tl}$	0.2 - 4.0	1.2	3.3	5.0	6.0
	All			13.0	19.6	26.0

Table 2. Radiological features of grate wastes produced by 10 different big coal-fueled power plants and calculated air absorbed dose-rate for various geometry of irradiation.

#### REFERENCES

- (1) Lederer, C.M., Hollander, I.M., Perlman, I. "Table of Isotopes" Sixth Edition. John Wiley and Sohn, Inc., 1968.
- (2) Serdjukova, A.S., Kapitanov, J.T. "Izotopy radona." Moskva, Atomizdat, 1975.
- (3) Peňsko, J., Wochna, M. "Semiconductor Detection System for Rn-222 Determination in Atmospheric Air". Proceed. of Intern. Symposium on Nuclear Electronics and Radioprotection, Toulouse, March 4-8, 1968.

## REQUIREMENTS FOR TRITIUM MONITORING

M. W. Carter and A. A. Moghissi

Georgia Institute of Technology  
Office of Interdisciplinary Programs  
Atlanta, GA 30332

## 1. INTRODUCTION

Tritium is an interesting and important radionuclide due to its characteristics, production and distribution, uses, and behavior, especially its biological behavior. It represents the radioactive species of hydrogen and is given the special designation, tritium, along with its sister nuclides, protium and deuterium. The decay of tritium is by emission of a beta particle with a maximum energy of 18 keV and an average energy of 5.7 keV. These features, along with its relatively long half-life of 12.3 years, are important in the detection, measurements, and effects of this radionuclide.

Tritium is produced by several reactions in nature and is one of several radionuclides which are not only naturally occurring but are produced in abundance by man. It results from ternary fission and several other important processes of the present and projected nuclear industry. Several reviews contain relevant information on production and behavior of tritium including an excellent report by Jacobs (1) and the books by Evans (2) and Moghissi and Carter (3).

## 2. TRITIUM MONITORING

Systematic programs for monitoring of tritium have been in existence for several decades. The original efforts were directed towards the measurement and distribution of naturally occurring tritium and the understanding of its environmental behavior. When it was later produced and used widely in research activities, emphasis shifted to the health physics aspects related to its production and applications. Nuclear weapons tests resulted in the large production of tritium and its introduction into the environment. This is especially true for those thermonuclear tests which were conducted in the atmosphere. The monitoring program of the IAEA (4) has covered environmental tritium for several years, notably to measure tritium in precipitation.

Monitoring programs in and around the nuclear power reactors and other facilities are required by the U. S. regulatory agencies such as Nuclear Regulatory Commission and Environmental Protection Agency. An example of a thorough tritium monitoring program is given by Krieger, *et al.*, (5) and an example of monitoring for tritium in various chemical forms in a luminous dial painting operation has been presented by Moghissi, *et al.* (6).

The bioassay for tritium determination usually involves analysis for this radionuclide in urine samples. Schieferdecker (7) has reviewed the radio-bioassay program conducted by a large nuclear research center.

## 3. COLLECTION AND ANALYSIS

There are a number of important considerations which must be evaluated in establishing practicable and effective monitoring requirements for tritium.



One major requirement is the availability of adequate procedures for collection and analysis of tritium samples. The adequacy refers to the sensitivity and economics of the procedures.

On-line monitoring procedures are usually impractical unless other radionuclides are not present and the fluctuation of background radiation is small as compared to the radiation resulting from expected levels of tritium. In this case both ionization chambers and internal proportional counters are useful. The latter detection devices can tolerate comparatively more interferences than the former because of their pulse height discrimination capability. An excellent review of this subject and others related to tritium measurement methodology was prepared by NCRP (8).

Because tritium can appear in the environment in various chemical forms, the collection, the analysis and the hazard evaluation must take this peculiarity of tritium into account. For the purposes of collection and analysis we shall group tritium compounds into water, elemental hydrogen and the remaining compounds, which are usually organic.

Collection of water from air is carried out on a routine basis either by passing through a bubbler containing water or by freezing (8). Occasionally rechargeable adsorbers such as molecular sieves are also used. If low-level tritium measurements are required bubblers should not be used because a dilution by a factor of 10-100 reduces the sensitivity accordingly.

Collection of hydrogen from air is almost exclusively done by the Ostlund method (9) which consists of the addition of hydrogen carrier and its oxidation and collection on a palladium catalyst deposited on an adsorber.

Collection of other compounds from air depends upon the nature of the compounds and the requirements of the monitoring program. For example, particulates can be collected on a filter, whereas methane can be oxidized and collected as water (8). The collection of water and biota for tritium analysis does not pose any special problem except a complete isolation to avoid readily occurring moisture exchange with the atmosphere. Most routinely used analytical techniques for tritium require the conversion of the tritiated compound to pure water. Purification of water or urine can be done by distillation or azeotropic distillation. This latter technique is also useful for separation of water from biota (10). It consists of addition of benzene to be followed by refluxing of the mixture. Subsequent to the removal of water (and benzene) the remaining organic fraction can be oxidized (8) and the resulting water processed.

The analysis of water for tritium is usually carried out by liquid scintillation counting. Dioxane based mixtures are only of historical importance or may be useful in specific cases. The development of emulsions has increased the sensitivity of liquid scintillation counting and has decreased the cost of analysis. Due to the expense of the instrument it should be recognized that the mixture of water and scintillation liquid must be optimized in terms of the product of efficiency and water content to accommodate economic requirements of the measurement. For example, an optimized liquid scintillation system should be capable of incorporating 10 ml of water in a 25 ml vial (10:15) resulting in an efficiency of 22-25% with a background of 6-8 counts per minute. The optimum for urine is about 8:17 with a slightly reduced efficiency. The background for raw urine is variable and constitutes the major reason for sensitivities for urine which are inferior by a factor of 10 as compared to water.

#### 4. FREQUENCY OF MONITORING

Until recently rules of thumb have been used to establish requirements for the frequency of monitoring. ICRP (10) recommends monitoring frequencies related to the half-life of the radionuclide such as to permit an average dose estimate extended over a year. ICRP also recommends monitoring of the exposure via the critical pathway. To accommodate these requirements one needs to know the critical pathway and the approximate turnover rate of the medium which is being monitored. For example, tritium bioassay, if done quarterly, has very little chance of estimating the annual tritium dose because the biological half-life of tritium is 10 days. It can be readily demonstrated that the accuracy of the estimation of the average concentration of tritium in any medium is related to its effective turnover rate in that medium. The effective turnover rate is defined as the combination of the decay half-life of 12.3 years and the turnover rate of tritium in that medium. It is thus evident that either a continuous sampling is necessary or a knowledge of the turnover rate of tritium is required before an adequate monitoring program can be established.

#### 5. DOSIMETRY

Tritium exposures are compared to standards for soluble material incorporated into the body and for immersion. The soluble material may be inhaled, ingested, or obtained through skin absorption. A route of much lesser significance may be the introduction of organic forms of tritium from industrial sources and minor sources produced in the environment. Conversely a route of considerable significance is the ingestion of tritiated food stuff grown in a contaminated environment (11).

The exposures to humans from tritium taken into the body are dependent upon the time integrated energy deposited per unit weight of tissue. Therefore, we are interested in the form, intake, distribution, and residency pattern for all the body's tritium. Although precise equations have been developed which adequately describe tritium kinetics in the human body (12), because the input parameters for these data are unknown a dosimetry based on dynamic values may be associated with large errors.

Whereas the occupational exposure to tritiated water can be adequately described by an exponential function, such a function can not be used to estimate the radiation dose from tritiated compounds or the dose resulting from environmental release of tritium, although the released tritium may have been tritiated water. The reason lies in the conversion of tritiated water to tritiated organic compounds which follow different effective turnover rates than tritiated water. A dosimetry based on the turnover rate of tritiated water under these conditions may lead to a considerable underestimation of the dose. Because it can be assumed that under static equilibrium conditions no preference is given to any one of the hydrogen isotopes, a continuous sampling system can be used to estimate the average tritium concentration over an extended period such as one year and thus concentration (C) can be applied to calculate the dose (H) using the following equation which is based on static equilibrium conditions:

$$H \text{ (mrem/year)} = 0.1 Q \text{ (quality factor)} \cdot C \text{ (nCi/l)}$$

There has been some confusion in the terminology of various tritiated compounds. For example, the terms "loose water tritium" and "bound water tritium" have been used to describe aqueous and non-aqueous tritium, respectively, although the latter contains no water (13). In addition to tritiated

water there are several other forms of tritium. Tritium atoms association with organic and inorganic compounds should be appropriately termed organically and inorganically bound tritium. In both cases, certain hydrogen atoms are exchangeable and thus these atoms exchange with hydrogen atoms of water. Because of the complexity of the subject it would be impractical to distinguish among these forms of tritium for the purpose of dosimetry. It is, however, important to use terms which are consistent with the scientific terminology in describing the categories of tritium which occur in environmental and biological samples. We suggest the use of two categories, namely, aqueous and non-aqueous.

## 6. CONCLUSIONS

Effective and practical techniques for the collection, preparation, and measurement of tritium in environmental and biological systems are available for use. These methods are relatively simple to use and produce information and data which can be used in comprehensive tritium monitoring programs. Continuous samplers for collection of tritium from air or streams should be used whenever practicable. The sampling frequency for discrete samples should be about the same as the effective turnover rate of tritium in the medium which is being sampled. Obviously, if the expected dose is small, less frequent sampling is adequate. A dosimetry based on tritium dynamics requires analysis of non-aqueous forms of tritium.

## REFERENCES

- (1) JACCBS, D. G., Sources of Tritium and Its Behavior Upon Release to the Environment, U. S. Atomic Energy Commission, Washington, D.C. (1971).
- (2) EVANS, E. A., Tritium and Its Compounds, John Wiley & Sons, New York (1974).
- (3) MOGHISSI, A. A., CARTER, M. W., Tritium, Messenger Graphics, Phoenix, Arizona (1973).
- (4) International Atomic Energy Agency, Tritium and Other Isotopes in Hydrological Cycle, IAEA, Vienna (1967) and subsequent volumes of the same series.
- (5) KRIEGER, H. L., GOLD, S., KAHN, B., Reference 3, pp. 557-564.
- (6) MOGHISSI, A. A., TOERBER, E. D., REGNIER, J. E., CARTER, M. W., POSEY, C. D., Health Physics 18, 225 (1970).
- (7) SCHIEFERDECKER, H., Reference 3, pp. 737-749.
- (8) National Council on Radiation Protection and Measurements, "Tritium Measurement Techniques," NCRP, No. 47.
- (9) OSTLUND, H. G., MASON, D. S., Tellus, 26, 1 (1974).
- (10) International Commission on Radiological Protection, "Principles of Environmental Monitoring Relating to the Handling of Radioactive Materials" ICRP, No. 7.
- (11) KIRCHMANN, R., KOCH, G., ADAMS, V., van den HOEK, Reference 3, pp. 341-349.
- (12) MOGHISSI, A. A., PATZER, R. G., CARTER, M. W., Reference 3, pp. 314-322.
- (13) BOGEN, D. C., WELFORD, G. A., Health Physics 30, 203 (1976).

## A FIVE CHANNEL AREA MONITOR FOR GAMMA RAYS

A.R. Jones  
Atomic Energy of Canada Limited  
Chalk River Nuclear Laboratories  
Chalk River, Ontario, K0J 1J0, Canada

## 1. INTRODUCTION -

An area monitor should permit dose rate estimates both by someone occupying an area and by a supervisor remote from it.

Since dose-rates generally vary over a wide range in the same area, an area monitor should be furnished with detectors at different places to avoid larger uncertainties in the dose rate estimate. If people can occupy the area while there is a danger of abnormal dose rates, there should be meters and alarms at the detector locations.

The response of the area monitor should be fast enough to alert those in the monitored area before they are significantly exposed. At the same time, the statistical precision must be adequate for estimating dose rates, bearing in mind other sources of error.

For reliable operation, the monitor must have reliable power supplies, preferably operable for limited periods without line power. To test operation of all parts of the monitor a convenient method of exposing the detectors to radiation is needed.

These considerations shaped the design of the monitor whose description follows.

## 2. DESCRIPTION

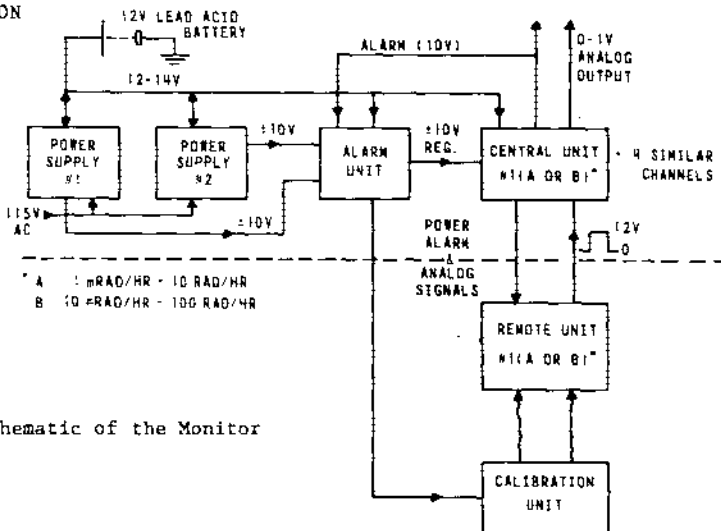

Figure 1. Schematic of the Monitor

Figure 1 is a schematic of the monitor and Figure 2 is a photograph of the different units which make up the monitor.

The units shown above the dotted line in Figure 1 are rack mounted in the plug-in modules illustrated in Figure 2.

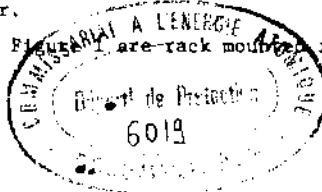



Figure 2. The Components of the Monitor

The two identical power supplies supply both + and -10 V, regulated, to the other units and keep a 12 V standby battery (Gel type lead acid) charged. Either power supply can fail in the short or open circuit modes without affecting operation. Line power can fail for up to 8 hours while the standby battery supplies energy even if all the five channels are in the 'alarm' condition.

The alarm unit:

- monitors the two power supplies and indicates when one of them has failed or if line power has failed.
- emits an audible alarm when any of the channels alarm. Five LED lamps are used to show which channel (or channels) is alarming. The alarm signals are reset from a switch on this unit.
- contains a switch for exposing the remote unit to the beta source in its calibration unit.

The central units receive the pulses from the remote units (containing a GM counter) and provide an analog signal proportional to the logarithm of the mean pulse repetition rate over a range of four decades. In the low range version the range is 1 mrad/h - 10 rad/h and in the higher range one 10 mrad/h - 100 rad/h. (The unit of dose engraved on the meter scale is 1 rad = 0.01 gray). A five channel area monitor can be composed of low or high range channels or a mixture of both. The two versions have the same circuits but the meter scales are differently engraved. For safety, the low and high range channels have different connectors to prevent connecting a low range remote unit to a high range local unit or vice versa.

The analog output signals are provided by a logarithmic count rate circuit. The smoothing time constant (T) is controlled so that it is inversely proportional to the dose rate (D)

$$T = \frac{a}{D} = \frac{b}{n} \quad (1)$$

where n is the average repetition rate of the pulses from the detector which is proportional to the dose rate. The statistical fluctuation of a counting rate circuit is given by the relation (1)

$$\text{Standard Deviation} = \frac{100}{\sqrt{2Tn}} \% \quad (2)$$

$$= \frac{100}{\sqrt{2b}} \% \quad (3)$$

which is independent of the dose rate. The importance of the varying time constant is that it allows the use of a single GM counter as a detector over a wide range without loss of statistical precision. It does mean very slow response at low dose rates but at higher dose rates the response is acceler-

ated so that people working near the detectors are not significantly exposed during the response period.

The analog output from the central units is available to drive external recorders, alarm circuits or a computer. It also drives a meter in the central unit and one in the remote unit. A variable alarm level can be set to trip at any point on scale. The alarm output (a 10 volt signal) is connected to the alarm unit and to the remote unit where a red lamp is energized.

The remote units contain GM counters (ITT type 3G70 or 3G500) which have the maximum sensitivity for their range consistent with low counting losses (10% at full scale). Each unit has a high voltage supply for the Geiger counter to avoid the need for high voltage cable connections and to insulate each channel against the effects of failure in another. The output pulse from the GM counter cathode after amplification to 12 V is transmitted to the central units which have a threshold between 3 and 7 V which is safely below the GM counter pulse while providing good immunity to noise.

The low and high range units only differ in the GM counter used.

The calibration units contain a 3.7 MBq  $^{90}\text{Sr}/^{90}\text{Y}$  source mounted in a wheel which is normally positioned to shield the GM counter (and any personnel working on the monitor) from the beta rays emitted. The wheel can be rotated on a remote command from the alarm unit to expose the GM counter to the source. Between the detector and source there is an aluminum wedge whose position can be adjusted to obtain a desired output from the monitor.

### 3. PERFORMANCE

Figure 3 shows the energy dependence of each GM counter. It was measured in counts/Roentgen and energy dependent factors were used to convert the exposure to dose. The factors have been previously derived from measurements made with a realistic phantom (2). It can be seen that above 0.1 MeV the sensitivity of the filtered counters is approximately constant.

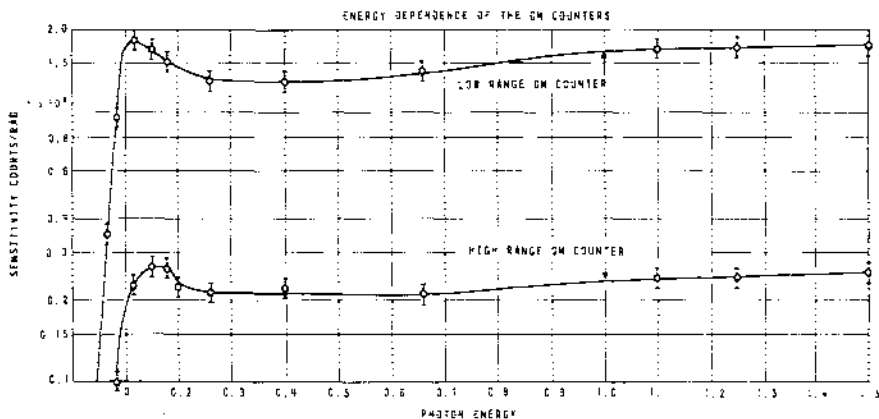

Figure 3. Energy Dependence of the GM Counters

The temperature dependences of the central and remote units were tested separately because it is likely that the remote units could be exposed to a wider temperature range. No change in response was observed in the central or remote units over the range  $-30^{\circ}$  to  $+50^{\circ}\text{C}$ . To avoid temperature dependence in this range the logarithmic element in the central unit is thermostatically controlled. Exposure of both units to relative humidity in excess of 90% produced no change in response either.

Linearity of both high and low ranges was checked over the scale range. In addition the analog output is also proportional to the logarithm of the dose rate for one decade below the bottom of scale.

Both high and low range units were subjected to continuous exposure at 10,000 R/h and in both cases an off-scale indication was maintained.

The statistical precision of the monitor was tested by exposing the remote unit at various rates and sampling the output in a random manner while each rate was held constant. The results are shown below.

Standard Deviation in %		
Indicated Dose Rate	Calculated s.d.	Measured s.d.
2.2 mrad/h	13.4	15
34	13.4	9
410	10.1	7
3.2 rad/h	3.9	4

The standard deviation was calculated using equation (3) with an additional fixed time constant of 0.2 s. The fixed time constant provides some additional precision at high dose rates without adding any appreciable delay (in comparison with human reaction time).

The response time is not defined by a simple time constant because it is changing during the transient from one dose rate to another (3). The table below shows the response time to 80% of the final reading for instantaneous changes from one dose rate to another. Also given is the dose absorbed during the response period.

Transient From To (mrad/h)	Time to reach 80% of final reading (Seconds)	Dose absorbed during response (mrad)
1 10	32	0.09
1 100	4.3	0.11
1 1000	0.32-1	0.09-0.28
1 10000	0.32-1	0.9-2.8

These measurements were made with the low range unit. The response times are similar for the high range unit but the absorbed doses are ten times higher. It can be seen that the response is very slow at the lower end of the scale but the dose absorbed while the monitor is responding is trivial.

#### 4. ACKNOWLEDGEMENT

I wish to thank D. Enns, B. MacDonald and W.F. Richter for their help in developing the monitor.

#### REFERENCES

- (1) W.J. Price. Nuclear Radiation Detection. McGraw-Hill. p. 67 (1964)
- (2) A.R. Jones. Proposed Calibration Factors for Various Dosimeters at Different Energies. Health Physics 12, p. 663. (1966)
- (3) A.R. Jones. A Linear Counting-Rate Circuit with Constant Statistical Precision. Nuclear Instruments and Methods 126, p. 313. (1975)

## A TRANSPORTABLE MONITOR FOR TRITIATED WATER VAPOUR

R.V. Osborne and A.S. Coveart  
Atomic Energy of Canada Limited  
Chalk River Nuclear Laboratories  
Chalk River, Ontario, K0J 1J0, Canada

## 1. INTRODUCTION

Measuring tritiated water vapour (HTO) at CANDU nuclear power stations and around experimental heavy water reactors is complicated by the presence of gamma radiation and noble gas radionuclides - both fission and activation products. The monitor described in this paper has been designed to complement portable and fixed monitors (1), (2), (3), by providing a compromise between transportability and reduced response to radioactive noble gases. Other features in the monitor desired by users are: the ability to measure down to 0.1 maximum permissible concentrations ( $0.1 \text{ (MPC)}_a$ ,  $1 \mu\text{Ci/m}^3$  or  $37 \text{ kBq/m}^3$ ), battery operation for at least 30 minutes, a response rapid enough for "sniffing" HTO leaks, robust construction suitable for the industrial conditions of a power station, and ease of operation - i.e., few controls or adjustments. Additionally, the monitor uses, where possible, components and sub-assemblies from other monitors to simplify both design and maintenance.

## 2. DESIGN OF TRITIUM DETECTOR

The currents from four 1.3 litre ionization chambers are combined to give a signal proportional to the concentration of tritiated water vapour (HTO) in sampled air as shown at the top of Figure 1. Ionization chamber #1, through which part of the sampled air passes, responds to HTO activity plus noble gas activity plus local gamma radiation. Water vapour is removed from the other part of the sampled air (as described below) and this air passes through ionization chamber #2, identical in geometry to #1, which therefore responds to the noble gas activity plus local gamma radiation. Sealed ionization chambers #3 and #4, concentric with #1 and #2 respectively respond only to the local gamma fields. The sizes of chambers #1 and #2 are adjusted so that the currents from them resulting from noble gas activity are equal. The sizes of the chambers #3 and #4 are adjusted so that their currents resulting from gamma radiation are equal to those from #1 and #2 respectively. By polarizing the chambers as shown in Figure 1, the net current from the combination is equal to that caused by only the HTO in #1. Four chambers are needed rather than two for this double cancellation because a concentric arrangement is required for satisfactory cancellation of the signal from gamma radiation but identical dimensions and geometry are required for satisfactory cancellation of the signal from what may be a varying mixture of noble gas radionuclides.

Desiccants have been used for many years to obtain HTO-free signals for subtraction purposes but the capacity of the desiccant has limited the sampling time (see, for example, reference 4).

A continuous stream of dried sample air is obtained for this monitor as shown in the lower part of Figure 1. The sample air stream, after passing through the glass fibre air filter (and, if needed, a charcoal-loaded filter for iodine) and ion trap, divides in two parts: one going through pump P1 to the sampling chamber #1, the other going through one of the molecular sieve columns which are part of a commercially-available drier for compressed gases (5). When the solenoid valves V1 and V2 are open in the "a" direction (see



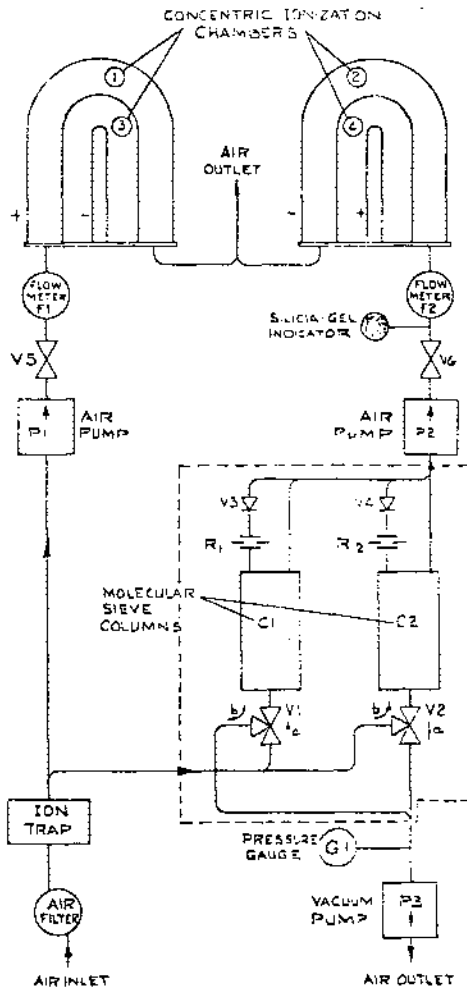

Figure 1. Flow Schematic of the Tritiated Water Vapour Monitor

Figure 1) then the wet air passes through column C1 to air pump P2 and on to the ionization chamber #2. The vacuum pump (P3) is connected to column C2 so that dried air from C1 flows through the check valve V4 and the flow-limiting orifice R2 thereby purging water from the sieve in C2. After 30 s, the solenoid valves V1 and V2 switch to the other direction ("b"), the sampled air is dried by the column C2 and some of the dried air is used to purge column C1. The valves continue to alternate in this manner. The continuous drying capability is maintained because the volume of air purging the column is greater than the volume that is dried since the pressure of the purging air is lower than that of the air when it is dried. Purging to a vacuum pump rather than compressing the sampled air as was originally proposed (6) to attain the pressure change is mechanically simpler. The orifices R1, R2 and the vacuum pump P3 have been selected so that a purging flow between 4 l/min and 20 l/min ensures that the dew point of a dried air flow of 5 l/min is not greater than  $-40^{\circ}\text{C}$ . If the sampled air is nearly saturated with water vapour (i.e., the dew point is  $\sim 20^{\circ}\text{C}$ ) then with an output dew point of  $-40^{\circ}\text{C}$  over 99% of the water vapour is removed. However if the sampled air is fairly dry (e.g., has a dew point of  $-20^{\circ}\text{C}$ , which is 5% relative humidity at  $20^{\circ}\text{C}$ ) then the purge flow and pressure have to be more critically controlled to attain a dew point closer to  $-70^{\circ}\text{C}$ , the minimum attainable with the particular orifices and vacuum pump used. Flow meters F1 and F2, valves V5 and V6, and pressure gauge G1 are provided so that the operating conditions can be monitored and adjusted. The silica gel capsule in the dry air line indicates a gross failure of the drying system. Such indication is important since the method is not fail-safe against drying failure. With chamber flows of 5 l/min the response time constant is  $\sim 20$  s.

When line-power fails, the vacuum pump is inoperative but air continues to be pumped to the ionization chambers. Valves V1 and V2 are de-energized and open both sieve columns to the sample air. Drying therefore continues up to the capacity of the sieve.

The gamma cancelling ability of this arrangement of ionization chambers has been detailed elsewhere; cancellation of 98% of the signal is practical (1). A similar cancellation is attainable for the gaseous radionuclides. Hence a gamma field of 1 mR/h ( $\sim 70$  pC/(kg·s)) causes a response equal to that from 0.2 (MPC)<sub>a</sub> of HTO. The net response to 100  $\mu\text{Ci}/\text{m}^3$  (3.7 MBq/ $\text{m}^3$ ) of a noble gas is equivalent to 0.4 - 2.0 (MPC)<sub>a</sub> of HTO depending upon the particular nuclide. This response is greater than that attained by the installed monitor noted in the introduction (3) which allows monitoring of HTO in the presence of noble gases concentrations two orders above the tritium but is adequate for many applications. For instance this continuous drying method has been successfully operated for two years at one of the CANDU nuclear power stations.

### 3. ELECTRICAL DESIGN

Two output signals are derived from the net ionization current; a seven-decade logarithmic signal which is supplied to a chart recorder with scale  $0.1 - 10^6$  (MPC)<sub>a</sub> and to a remote readout connector, and a digital signal which is supplied to a display with 0.01 (MPC)<sub>a</sub> as the least significant digit. Updating of the digital display may be at predetermined intervals, 6, 60 and 300 s, or at any one of these depending upon the magnitude of the ionization current. An alarm high level may be dialled in digitally for any concentration within the operating range and is tripped digitally. A low alarm level is tripped if zero digital signal is sensed in any updating period. All the supply voltages are derived from a 12 V rechargeable battery; normally the battery floats on the line-powered supply but if the line is removed then the battery is capable of supplying the monitor for several hours. All derived supplies, and the purge and ionization chamber pressures are monitored by a fault detection circuit which drives an audible alarm.

Any detected fault is identified on a display panel and the trace on the recorder is also modulated to indicate when the fault occurred. The only controls accessible to the casual user are display and alarm test push-buttons and a display reset push-button.

The amplifiers are sufficiently stable that only infrequent (less than weekly) adjustment of the amplifier zero is required even when measuring concentrations of the order of 0.1 (MPC), with other radiations absent. Since the electronic time constants are only a few seconds the overall response time constant is determined by the sampling time constant.

The complete monitor weighs 150 kg, mainly owing to the weight of the pumps, drier, battery, and carriage which is mounted on 20 cm diameter wheels for easy transport over uneven floors.

#### 5. ACKNOWLEDGEMENT

We appreciate the assistance of B.A. MacDonald in detailing the mechanical and electrical design of the monitor and the co-operation of R.K. Mohindra in operating the prototype drying unit at the Douglas Point Nuclear Power Station.

#### REFERENCES

- (1) OSBORNE, R.V. and COVEART, A.S. A Portable Monitor for Tritium in Air. Nucl. Instr. and Meth. 106, 181-187 (1973).
- (2) OSBORNE, R.V. and COWPER, G. Detection of Tritium in Air with Ionization Chambers. AECL-2604 (1966) (Atomic Energy of Canada Limited, Chalk River, Ontario).
- (3) OSBORNE, R.V. Central Tritium Monitor for CANDU Nuclear Power Stations. IEEE Trans. Nucl. Sci. NS-22, 676-680 (1975).
- (4) National Council on Radiation Protection and Measurements, NCRP Report No. 47 (1976). (P.O. Box 30125, Washington, D.C., 20014, U.S.A.)
- (5) Puregas Heatless Dryers, General Cable Corporation, Colorado, U.S.A.
- (6) OSBORNE, R.V. Monitoring Reactor Effluents for Tritium: Problems and Possibilities. p. 496 in TRITIUM, Moghissi, A.A. and CARTER, M.W., Eds (Messenger Graphics, Phoenix, Arizona, U.S.A.) (1973).

TRITIUM CONTAMINATION MEASUREMENT  
- A SIMPLE AND SATISFACTORY METHOD

G. D. Whitlock

Hughes Whitlock Ltd., Wells House,  
Pixifields Estate, Cradley, Malvern, England.

1. INTRODUCTION

Tritium surface contamination is difficult to measure because of the very low energy of its pure beta emission (18.6 KeV Max.). In practical terms this means that one has to be able to detect particles with a range of 1.5 mm in air and  $2\mu$  in a material of unit density. Furthermore, the tritium may be in the form of a thin film or a thick film, containing fluorescent, chemiluminescent, or volatile components. To be satisfactory for radiological protection purposes the measuring instrument should be able to detect all forms. The Whitlock Tritium meter described in this paper has this capability. It also has the ability to measure other more energetic betas, electron capture, X-rays and soft gamma rays.

2. DEFINITIONS

2.1 A Thin Source is presumed to be a molecular layer of Tritium contamination evenly distributed over a perfectly smooth surface. 2.2 A Thick Source is similarly distributed and uniformly active but  $8\mu$  or greater in thickness.

2.1 A Thin Source

A Thin Source in a vacuum produces a spectrum of emission/energy as shown in Fig. 1

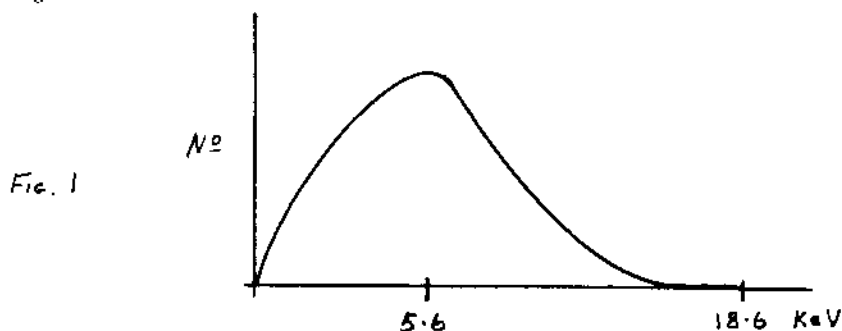

In air the max. range of the max. energy (18.6 KeV) beta is approximately 4 mm. Taking geometry into account, where the mean angle of emission is in the region of  $30^\circ$  to the surface, then the mean range of the max. energy betas is approx. 1.5 mm. These factors apply to all energies of beta particles emitted and the result is a very degraded spectrum as in Fig. 2(A). This shows the spectrum in air of beta particles emitted from a surface.

Fig. 2

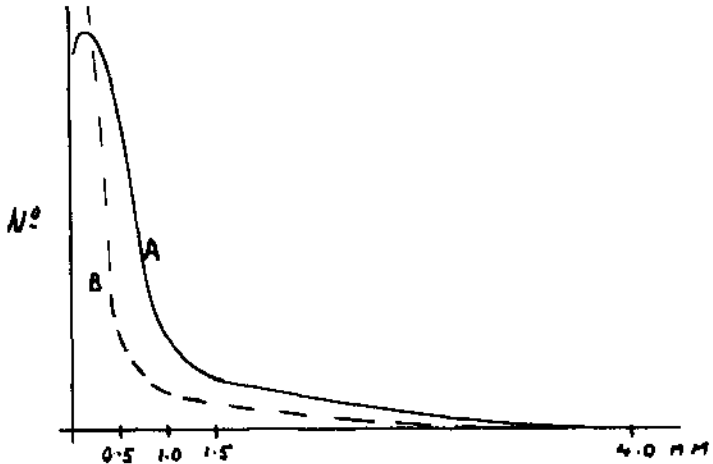

## 2.2 Thick Sources

Thick Sources present an even further degraded spectrum because of self absorption. Though the max. range of the max. energy betas is  $8\mu$  in a material of unit density the main range of max. energy particles is only  $2\mu$ . The spectrum of betas originating from  $8\mu$  below the surface is overlapped by the spectra of betas from other "layers" of activity closer to the air interface. The resulting spectrum of betas in air approximates to Fig. 2(B). In both cases the feature to note is the very small number of betas with a range  $> 1.0$  mm.

## 3. PRACTICAL CONSEQUENCES

### 3.1

The sensitive area of the radiation detector has to be very close to the source ( $< 1$  mm) almost irrespective of the activity present.

### 3.2

Surface scratches  $> 2\mu$  in depth are potentially infinitely thick sources of  $^3\text{H}$  contamination and require the detector to be even closer to the source.

### 3.3

A distance variation of as little as 0.025 mm (1 thou. inch) can significantly affect the measurement.

## 4. THE INSTRUMENT SPECIFICATION

A Whitlock Tritium meter (WTM) is capable of measuring Tritium surface contamination with a sensitivity of  $10^{-4}\mu$  Ci/cm<sup>2</sup> integrated over 100 cm<sup>2</sup> in a measuring time of 10 seconds. It consists of a thin large area (100 cm<sup>2</sup>) windowless plastic scintillator viewed by two 30 mm dia. photomultipliers in coincidence. Associated discriminators

amplifiers, digital display timer and H. V. supply are powered by re-chargeable batteries. The whole area of the detector is maintained at a distance of  $0.5 \text{ mm} \pm 0.025 \text{ mm}$  from the surface being measured by a disposable rubber molding. This molding also forms a sealing ring to exclude light, when a partial vacuum of half an atmosphere is developed in the measuring area, by manual operation of the single action vacuum pump incorporated in the body of the instrument.

## 5. THE INSTRUMENT IN USE

The instrument in use is placed on a smooth metal plaque provided as an accessory. The vacuum pump handle is released and a vacuum is established which keeps the instrument firmly in position. Under the measuring conditions now established, where the area, pressure and all important distance are kept constant, the instrument is switched on and several 10 second measurements are taken initially, to determine the background for the area, within reasonable statistics. Depressing the pump lever releases the vacuum, resets the scaler and allows the instrument to be positioned on the surface to be measured. Release of the pump lever provides a vacuum and starts a one or 10 second measurement of contamination. As each measurement is of 100 cm<sup>2</sup>, large areas of laboratory working surfaces can be surveyed very rapidly. It has been shown that to obtain meaningful measurements with any detector the distance factor must be kept within very close tolerances. If this requirement cannot be met, say on floor or door handle surfaces, direct surface measurements cannot be made without the risk of a false negative. In these circumstances another accessory enables the instrument to measure wipes or smears.

## 6. SMEARS

Smears consisting of 50 mm dia. filter papers or aluminium discs are wiped over the contaminated surface, placed active side uppermost in a 1 mm deep recess provided and measured with the instrument. Assuming 10% of the contamination has been removed by the smear some compensation can be made by smearing ten times the normal wipe area or increasing the measurement time to 100 secs. When measuring smears the safest presumption is that the activity is being presented in a thick source form, particularly if a liquid spill has been wiped. It is interesting to measure both sides of the filter paper after wiping liquid contamination as it is often found that a small amount of activity can be detected on the side which has not been in contact with the wiped surface. This can give some indication of the total absorbed activity.

## 7. COMPARISON WITH LIQUID SCINTILLATION COUNTING

### 7.1 Instrumentally

Instrumentally the electronics are very similar apart from compactness and battery operation of the Tritium meter (WTM) and the 3 channel capability of the liquid Scintillation Counter (LSC). The major difference is apparent when one can take a representative sample of surface contamination to the LSC to obtain the advantage of the  $4\pi$  geometry and the elimination of air absorption. This advantage is partially counter-balanced by chemical interference (quenching) of the scintillation process and a small possibility of self absorption. The WTM measures smears on site and information is immediately available for decisions.

## 7.2 Fluorescent Compounds

Fluorescent Compounds do not affect the WTM because the photomultipliers only receive light photons "piped" to them by total internal reflection. Furthermore both photomultipliers have to detect a photon within the pre-set coincidence time for an event to be recorded. Fluorescence of sufficient intensity to introduce photons through minor imperfections in the plastic scintillator surface in significant numbers would be visible to the naked eye. In LSC the fluorescence is inserted in the optical system. From then on it is the same in both instruments and the number of false events detected depends upon the timing of the coincidence circuits.

## 7.3 Chemiluminescence

Chemiluminescence is generated when certain chemicals are introduced into the liquid scintillation "cocktail" and false positives can be obtained from chemical "whiteness" in paper smear material. This situation is not possible with the WTM.

## 7.4 Thin and Thick Source Identification

Only the WTM is capable of measuring contamination directly on surfaces but it is interesting to note that in Fig. 2 the spectrum of energies emanating from a thick source is displaced to the left of that obtained from a thin source. This is similar to the spectral shift caused by different levels of quenching in an LSC. The degree of quenching can be measured by channels ratio techniques. The WTM can be fitted with pushbutton selected channels and the ratio of two successive measurements in "infinity" and "window" modes of counting would show whether a thick or thin source was being measured.

## 7.5 The Presence of Volatile Tritium

The presence of volatile Tritium or outgassing from the surface is indicated by the WTM by gross variability of count on successive measurements of the same surface area. During measurement the WTM produces a vacuum of  $\frac{1}{2}$  atoms. in the measuring "chamber" and if under these circumstances the surface contamination changes to gaseous activity the geometry and air absorption characteristics drastically change. This phenomena is sometimes exhibited when measuring wet smears and if successive measurements are carefully recorded it may be possible to determine diffusion characteristics or quantify the volatile fraction. The LSC cannot give these indications.

## 7.6 Smears vs. Direct Measurements

The shortcoming of smears measured by either LSC or WTM is related to the nature of the surface being wiped. If the surface is covered with a large number of small scratches a large proportion of the activity could be deposited at the bottom of each miniature valley.

## 8. CONCLUSION

The Whitlock Tritium Meter provides a simple and satisfactory answer to the complex problem of measuring Tritium surface contamination for radiological protection purposes.

## MONITEUR POUR LA DETECTION EN CONTINU DU TRITIUM DANS LES EFFLUENTS LIQUIDES

S. DESCOURS, P. GUERIN, A. HADDAD  
Service de Protection et des Etudes d'Environnement  
Centre d'Etudes Nucléaires de Grenoble  
Commissariat à l'Energie Atomique  
85 X 38041 GRENOBLE CEDEX (FRANCE)

### 1. INTRODUCTION

Dans un but de radioprotection, un système de détection du tritium a été étudié pour pouvoir suivre en continu la concentration en tritium dans les effluents liquides. Ce système peut être mis en oeuvre à la sortie d'une canalisation de rejet d'eau susceptible de contenir du tritium et par exemple, sur un écoulement d'égout.

Le principe adopté est celui de la détection de scintillations sur des sphères de scintillateur plastique autour desquelles passe, après filtration, le liquide à mesurer. Ces scintillations sont vues par deux photomultiplicateurs dont le circuit électronique comporte deux voies de mesure pour la différenciation entre tritium et autres émetteurs  $\alpha$ ,  $\beta$ ,  $\gamma$ .

### 2. DESCRIPTION DU MONITEUR

La figure 1 montre le schéma de principe du moniteur, schéma qui fait ressortir les éléments suivants :

- les scintillations prenant naissance au sein de la cellule sont vues simultanément par les deux photomultiplicateurs couplés à un circuit électronique de coïncidence
- l'ensemble -cellule et photomultiplicateur- est confiné dans un blindage de plomb
- le circuit hydraulique de l'effluent comporte un système de filtration et un débitmètre
- par un jeu de vannes, on peut faire circuler de l'eau propre à travers la cellule pour décontamination.

#### 2.1. Caractéristiques de la cellule

A l'intérieur du blindage de plomb (5 cm) est aménagé un espace pour recevoir un panier parallélépipédique en plexiglas contenant les sphères de scintillateur plastique : ces sphères de diamètre compris entre 0,6 et 0,8 mm sont du type NE 102 A de Nuclear Entreprise commercialisées par NUMELEC-FRANCE. Ce panier rempli de sphères sur une épaisseur de 30 mm environ est disposé en regard de deux ouvertures circulaires munies de plaques de plexiglas face aux photomultiplicateurs (type EMI 9635 QB).



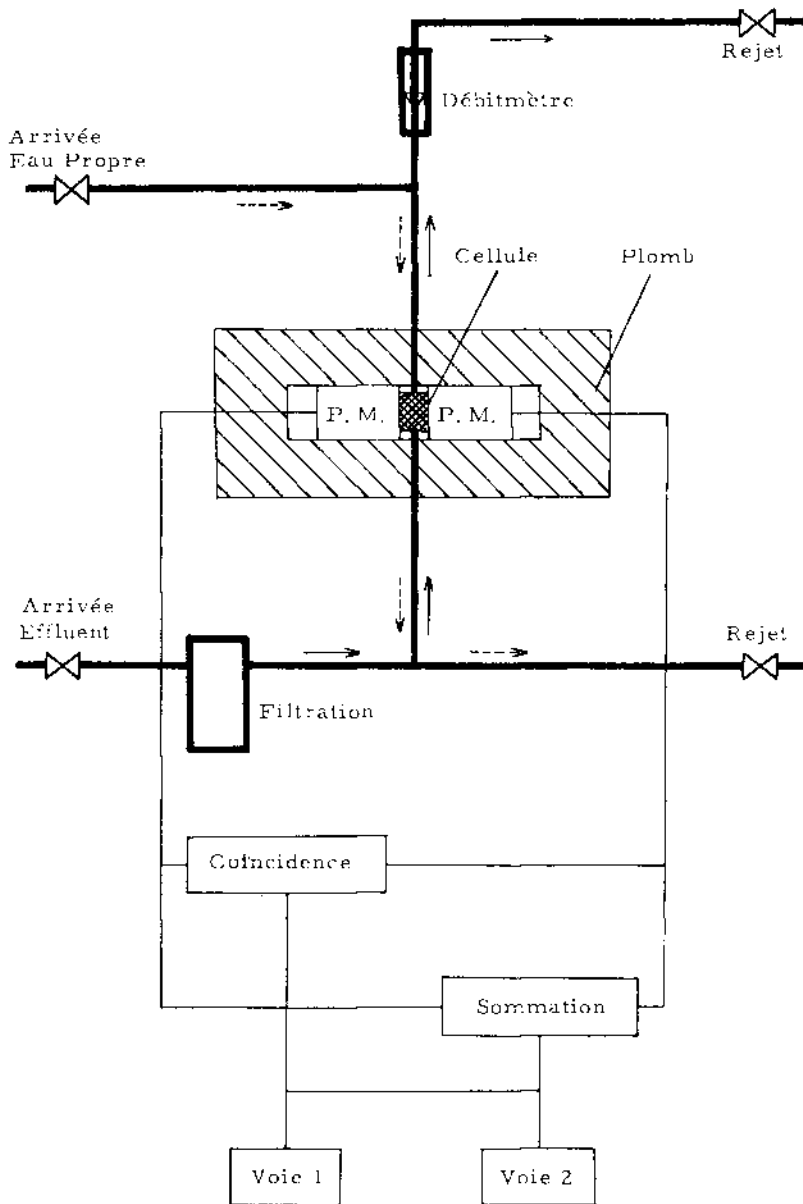

Figure 1 : Schéma de principe du moniteur

## 2.2. Circuit électronique

Le circuit électronique adopté est celui utilisé couramment en scintillation liquide avec un système de coïncidence et deux amplificateurs indépendants : ceci définit deux voies de mesures distinctes appelées "tritium" et " $\alpha, \beta, \gamma$ " permettant de discriminer le tritium des autres contaminants par réglage des seuils et des gains.

## 2.3. Circuit hydraulique

Il est prévu sur le circuit hydraulique un système de filtration pour éviter tout dépôt de particules dans la cellule : deux filtres de type cartouche FILTRO (pores de 150  $\mu\text{m}$  et 5  $\mu\text{m}$ ) ont montré, en fonctionnement normal continu sur un circuit d'écoulement d'égout, que pendant une période d'au moins 7 jours, aucun colmatage n'était sensible avec un débit moyen de 0,75 l. mn<sup>-1</sup>. Pour des cas très particuliers de liquides très chargés ou colorés, il est prévu d'ajouter un système de décolmatage automatique ou de distillation en continu. Pour pouvoir éventuellement rincer la cellule pour décontamination, un jeu de vannes permet de faire circuler de l'eau propre dans la cellule.

## 3. RESULTATS DE FONCTIONNEMENT

Avec de l'eau propre et en l'absence de tritium, le bruit de fond du moniteur est de 8 imp. mn<sup>-1</sup> dans la voie "tritium" et 18 imp. mn<sup>-1</sup> dans la voie " $\alpha, \beta, \gamma$ ". Pour une eau contaminée à  $3 \cdot 10^{-3}$  Ci. m<sup>-3</sup> en tritium (1 CMA Population), l'on obtient 30 imp. mn<sup>-1</sup> dans la voie "tritium". Le seuil d'alarme pouvant être fixé au double du bruit de fond, sera donc sensiblement de 1/4 CMAP. Avec de l'eau contaminée à raison de  $10^{-5}$  Ci. m<sup>3</sup> en <sup>144</sup>Ce, les résultats obtenus sont les suivants : 38 imp. mn<sup>-1</sup> dans la voie "tritium" et 300 imp. mn<sup>-1</sup> dans la voie " $\alpha, \beta, \gamma$ ". Suivant la contamination en tritium mesurée, le circuit de rinçage avec de l'eau propre permet une décontamination plus ou moins rapide de la cellule : environ 4 mn pour une mesure de 1 CMAP et 20 mn pour 10 CMAP.

INSTRUMENTAL METHOD FOR MEASUREMENT OF  $^{131}\text{I}$  IN MILK

G. K. Riel, D. P. Coveil, E. I. Cordeva and D. L. Love  
 Naval Surface Weapons Center  
 White Oak, Silver Spring, Maryland 20910

## SUMMARY

A prototype detector for radiiodine in milk has been tested using aqueous solutions of  $^{131}\text{I}$ . Extrapolation of the test results indicate that a detector with a 0.25 liter sample volume can measure  $^{131}\text{I}$  in milk to 0.5 picocuries per liter, with no chemical processing of the sample. Beta gamma coincidence counting keeps the background low. In this experiment we evaluated the counting efficiency, the accidental coincidence rate, and the cosmic ray coincidence background.

## 1. INTRODUCTION

This instrumental method is intended to replace radiochemical procedures for the analysis of  $^{131}\text{I}$  in milk. To compete with these procedures (1) (2), we must identify the  $^{131}\text{I}$  by its radiation instead of its chemical properties, reject other sources of radiation and achieve an efficiency for radiiodine so that a sensitivity of 0.5  $\mu\text{Ci l}^{-1}$  is achieved. We use beta gamma coincidence counting to achieve these goals. All  $^{131}\text{I}$  beta decays are accompanied by a suitable gamma photon, and 81% are in coincidence with the 364 KeV gamma (3).

## 2. DETECTOR

The short range of beta particles in milk makes efficient detection difficult. To overcome this difficulty, we use 167 rods of Pilot "B" plastic scintillator 0.25 cm diameter by 9 cm long, Fig. 1. These rods were mounted in a cup which held the sample. They were viewed at one end by a phototube. The volume of the cup, about 130 cc, was approximately equally divided between rods and sample. The cup, beta detector, and sample assembly was inserted into the 5.1 cm diameter x 7.6 cm deep well of a 12.7 diameter x 12.7 cm high NaI(Tl) gamma scintillation detector.

## 3. COUNTING SYSTEM

We assembled the beta gamma coincidence counting system from standard nuclear instrument modules. Important parameters were the beta and gamma energy windows, the coincidence (time) window, and the beta signal delay. The beta detector has a faster rising signal than the gamma detector. Therefore, we delayed the beta signal to maximize the coincidence rate, Fig. 2. To obtain maximum counting efficiency we had to set the energy windows to include some low energy noise. Thus, the gamma detector counted about 1.5 counts for each  $^{131}\text{I}$  decay, and the beta detector counted about 2 counts for each decay. We were able to lower the threshold to a gamma rate of 14 and a beta rate of 70 counts per  $^{131}\text{I}$  decay before any increase in the coincidence rate was seen. Setting the gamma window on the main peak gave an order of magnitude reduction in the single event rate at a cost of a factor of three in the coincidence rate. The same window on the beta channel cut the coincidence rate to 7% of the rate with the normal threshold. The coincidence (resolving time) window was normally 50 nsec. At 35 nsec and less, coincidence events were lost. Upper Level discriminator signals from beta and gamma channels were counted in coincidence to measure the cosmic ray event rate. Figure 3 shows the cosmic ray event rate as a function of energy. Extrapolating this rate to the  $^{131}\text{I}$  window yields 15  $\text{cpm (MeV)}^{-1}$ , or 9  $\text{cpm}$  in the 600 KeV window.

## 4. RESULTS

Figure 4 shows the coincidence rate as a function of time. The disintegration rate of  $^{131}\text{I}$  is plotted as a solid line. Coincidence counting efficiency,

the ratio of the counts to the disintegrations, is 10%.

### 5. EXTRAPOLATION TO FULL SIZE DETECTOR

Our goal for the measurement of  $^{137}\text{I}$  in milk is a lower limit of detection (LLD) of  $0.5 \text{ pCi l}^{-1}$ . Pasternack and Harley (4) [For further discussion see Bowman and Swindle (5)] define LLD as:

$$\text{LLD} = \gamma(k_\alpha + k_\beta) (C_{B+S} + C_B)^{1/2} \quad (1)$$

where:

$\gamma$  converts units of Cs to units of LLD

$k_\alpha = 1.645$  (5% chance of false detection)

$k_\beta = 1.287$  (93% confidence of true detection)

$C_{B+S}$  is the count during the measurement

$C_B$  is the background count, measured for the same time

$$\text{LLD} = 0.5 \text{ pCi/l}$$

$\gamma$  is defined by the detector volume (V), counting time (T) and detection efficiency ( $\epsilon$ ):

$$\gamma = (\text{pCi/DPM})(\text{VTE})^{-1} = (0.22 \text{ VT})^{-1} \quad (2)$$

$$C_B = \frac{(\text{LLD})}{\gamma} = 0.11 \text{ VT} \quad (3)$$

Therefore:

$$C_B/T \leq 1.41 \times 10^{-3} \text{ V}^2/T = 5.5 \times 10^{-2} \text{ V} \quad (4)$$

Solving (4) with various values of VT yields Table I.

TABLE I  
Parameters of detector to measure  $^{137}\text{I}$  in milk at  $0.5 \text{ pCi l}^{-1}$

Active Volume liters	Counting Time Minutes	Background Rate CPM
0.25	1600	0.13
0.25	1300	0.10
0.25	720	0.05
0.50	1440	0.48
0.50	900	0.25
0.50	360	0.10

### 6. DISCUSSION

Realization of the detector described in Table I rests on three conditions:

- (1) Maintain  $\beta$  efficiency.
- (2) Maintain the same gamma efficiency while increasing the well volume to accommodate the larger detector.
- (3) Keep the coincidence background rate to that specified by the detector volume and counting time.

Let us assess the chances of meeting these requirements.

- (1) Our experience with scintillator rods indicates that light may be collected satisfactorily up to a length to diameter ratio of 100. To stay within this, we limit the length of the rods to 20 cm, while keeping the diameter the same (0.25 cm) as in the prototype.
- (2) The NaI(Tl) well detector for gamma needs a well volume of 0.5 liter to accommodate an active volume of 0.25 liter. We obtain most of this by increased length. The diameter increased only 11% over the prototype. This represents only a 4% loss of  $^{137}\text{I}$  photons (6).

(3) Lieshout, et al (7) discuss sources of background in large NaI(Tl) detectors. These may be separated into internal, various gamma and cosmic rays. Detection by the beta detector of a source internal to the gamma detector is very unlikely, and the internal background of the beta detector is very low. Penetration of both detectors by a gamma photon is unlikely, and the beta detector's efficiency for gamma is low. Thus, the principal coincidence background will be cosmic rays.

May and Marinelli (8) discuss the components of the cosmic ray background and their effect on the background of a low level scintillation detector. The ionizing component is readily detected in an anticoincidence guard. This is the major component, and in this laboratory we have achieved over 90% reduction in cosmic ray background with such a guard (9). The neutral component while penetrating the guard is unlikely to cause a coincidence count. However, a neutron may be captured in a plastic rod. The beta detector would detect such an event, and the resulting 2.2 MeV gamma photon has a high probability of being detected by the gamma detector. The upper energy cutoff, set at about 0.8 MeV for  $^{131}\text{I}$  will reject most of the neutron capture gamma photons.

Thus to control background we have the techniques of coincidence, anti-coincidence and energy resolutions. With these we expect to achieve a cosmic background event rate close to 0.1 CPM.

#### 7. CONCLUSION

Our tests with a prototype  $\beta$ - $\gamma$  coincidence detector for  $^{131}\text{I}$  in milk indicate that a lower limit of detection of 0.5 pCi $l^{-1}$  is feasible. Replacing present chemical techniques with this instrumental method has significant economic advantages. The speed of this detector in measuring higher  $^{131}\text{I}$  concentrations would be valuable in an emergency situation.

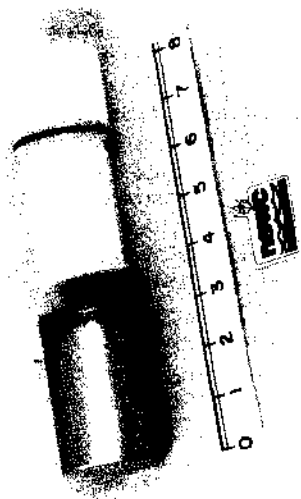

Figure 1  
BETA DETECTOR

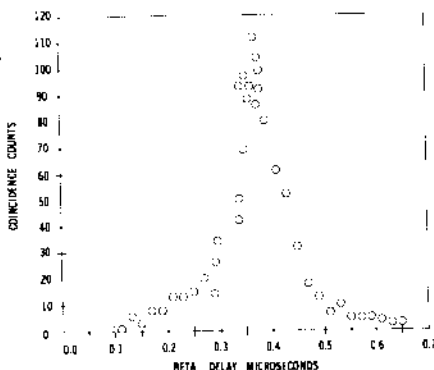

FIG. 2 COINCIDENCE COUNTING RATE V.S. BETA DELAY USING 35 NANOSECONDS RESOLVING TIME AND 0.5 MINUTE COUNTING TIME.

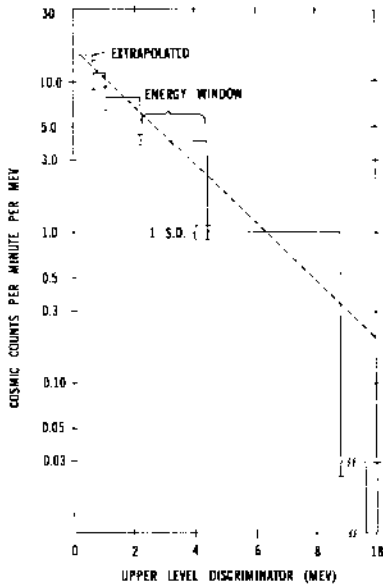

FIG. 3 COSMIC RAY COINCIDENT EVENT RATE V.S. UPPER LEVEL DISCRIMINATION (DIFFERENTIAL SPECTRUM DETERMINED FROM INTEGRAL DIFFERENCES)

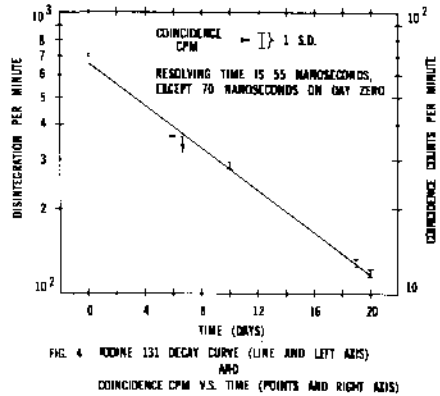

FIG. 4 RADIUM 131 DECAY CURVE (LINE AND LEFT AXIS) AND COINCIDENCE CPM V.S. TIME (POINTS AND RIGHT AXIS)

#### REFERENCES

1. IAEA 1973 "Control of Iodine in the Nuclear Industry" Technical Report No. 148, Vienna.
2. Radiation Management Corporation, 1976 "High Sensitivity Radiochemical  $^{131}\text{I}$  Measurement in Milk" 3508 Market Street, Philadelphia, PA 19104
3. National Academy of Sciences, National Research Council, 1964 "Nuclear Data Sheets".
4. Pasternack, B. S. and Harley, N. E. 1971 "Detection Limits for Radionuclides in the Analysis of Multi-Component Gamma Ray Spectrometer Data" Nuclear Instruments and Methods, 91 No. 3, 533.
5. Bowman, W. B. II, and Swindle, D. L. 1976 "Procedure Optimization and Error in Analysis for Several Laboratory Routines in Determining Specific Activity" Health Physics, 31, 355.
6. IAEA 1973 "Radiation Protection Procedures" Safety Series No. 38, Vienna.
7. Lieshout, R. Van, Wapstro, A. E., Ricci, R. A. and Girgis, R. K., 1965 "Scintillation Spectrum Analysis" in "X-ray Spectrometry", Sieghahn, North Holland, Amsterdam.
8. May, R. and Marinelli, L. D., 1964, "Cosmic-Ray Contributions to the Background of Low-Level Scintillation Spectrometers in the Natural Radiation and Environment" University of Chicago Press.
9. Bowman, W. B. II and Swindle, D. L. 1976 "Procedure Optimization and Error Analysis for Several Laboratory Routines in Determining Specific Activity" Health Physics, 31, 355.

SOME REGULARITIES OF FORMATION OF THE NEUTRON SPECTRA  
OUTSIDE THE SHIELDING OF PROTON ACCELERATORS

Alejnikov V.E., Gerdt V.P., Komotchkov M.M.  
Joint Institute for Nuclear Research, Dubna, USSR

Neutron energy spectra are known to be the basis for obtaining the most of radiation quantities of neutron fields. The authors (1-4) have been the first to systematize neutron spectra outside the shielding of high energy accelerators. To our mind it needs further development. On the one hand, the improvement of measurement methods and spectra unfolding and, on the other hand, increasing information on spectra for various shielding configurations, its composition and the upper limit of the neutron energy range made it necessary to continue such development. In this case one can provide some regularities in spectra formation. Both aspects of the problem are considered here.

An essential feature in the neutron spectrum obtaining is spectra unfolding, i.e. solving the system of integral equations of the following form (3,4)

$$\int_{E_{\min}}^{E_{\max}} K_i(E) \Phi(E) dE = N_i, \quad (I)$$

where  $\Phi(E)$  is differential flux density (spectrum) of neutrons ( $n \cdot cm^{-2} \cdot c \cdot MeV$ );  $N_i$  is the counting rate of the detector with the  $i$ -th moderator (ppc);  $K_i(E)$  is the response function of the  $i$ -th detector as a function of neutron energy  $E$  ( $p \cdot cm^2 \cdot n^{-1}$ );  $E_{\min}$ ,  $E_{\max}$  are energy interval, where neutron spectra are obtained. In our calculations we assumed  $E_{\min} = 10^{-8}$  MeV and  $E_{\max} = 10 E_0$ , where  $E_0$  is the upper limit of the neutron energy range. Such a choice of  $E_{\max}$  is convenient for using the *a priori* information on the existence of the neutron spectra limit  $E_0$  (see below).

Six detectors have been used ( $i=1+6$ ). Five of them composed a Bonner spectrometer with such response functions as

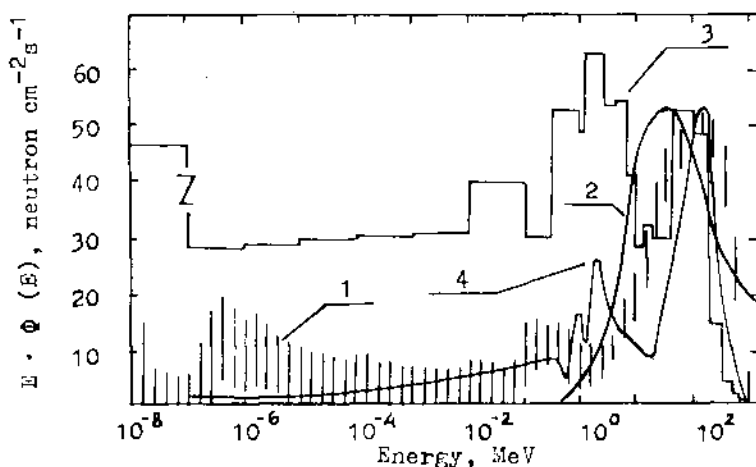

Fig.1. "Hard" neutron spectra: 1 - outside the uniform concrete shielding of the JINR synchrocyclotron (8); 2 - outside the earth shielding of the CERN proton synchrotron (2) (rel.un.); 3 - outside the side shielding of the 800 MeV proton accelerator of the Los-Alamos meson factory, calculated in (9) (rel.un.); 4 - outside the concrete shielding of 500 g/cm<sup>2</sup> thickness for falling neutrons, emitted from the target at an angle of 70° to the 18.2 GeV proton beam, calculated in (10).

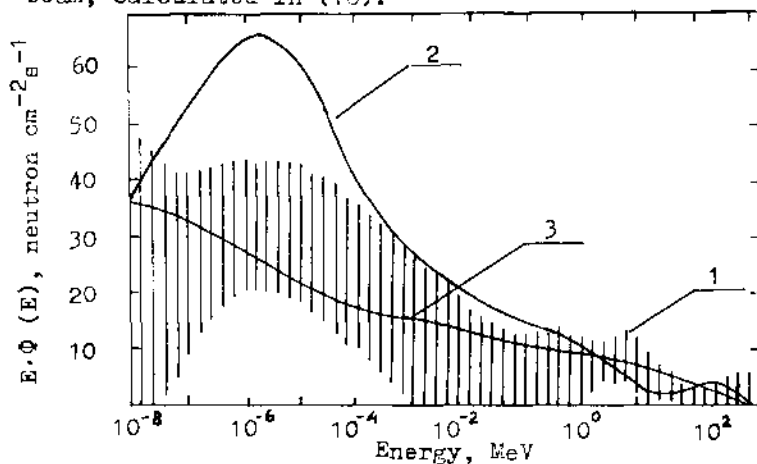

Fig.2. "Soft" neutron spectra: 1,2 - outside the shielding of the JINR synchrocyclotron with openings (8) (the curve is drawn across middle points of the uncertainty region); 3 - outside the steel shielding of the 7 GeV synchrotron (2).



in (4), where we used the statistical regularization method (5-7) to unfold the neutron spectra. The sixth one was a carbon detector, it registered neutrons in accordance with the reaction  $^{12}\text{C}(n,2n)^{11}\text{C}$ , its cross-section is assumed to be constant at energies  $E \gg 20$  MeV and equal zero at  $E < 20$  MeV. Thus at  $i=6$  the measured quantity in eq.(I) is the neutron flux  $\Phi_0$  at the energy of  $E > 20$  MeV. Note that the application of the data obtained by a carbon detector in the form of integral equation (I) is more consistent than that applied in the method of ref.(4), where the spectra parametrization in the high energy range  $E > 20$  MeV was used. Besides we considered the upper limit of the neutron energy range  $E_0$  now in the framework of the statistical regularization method. The proper spectrum limitation can be given in the form of the integral equation

$$\int_{E_0}^{E_{\max}} \Phi(E) dE = \alpha \Phi_0, \quad (\text{II})$$

which together with eq.(I) was used to unfold the spectrum by the statistical regularization method. In equation (II)  $\alpha$  is a sufficiently small value.

Fig.1 shows the neutron energy distributions outside the uniform shielding of high energy proton accelerators. For visual evidence the spectra were normalized to the maximum value of the function  $E \Phi(E)$  in the high energy neutron range. The analysis of measurement results and calculations of neutron energy distributions outside the uniform shielding of accelerators reveal that for majority of neutron spectra  $\Phi(E)$  the function  $E \Phi(E)$  has maximum in the high energy range. Maximum of the most "hard" spectra is localized nearby  $\sim 100$  MeV. The maximum localization of the function  $E \Phi(E)$  outside the uniform side shielding of accelerators depends weakly on the maximal proton energy and depends mainly on the shielding-source geometry.

Holes and slits in the shielding are responsible for considerable increasing the part of low energy neutrons in the spectrum due to the scattering radiation passing through these openings. Fig.2 shows neutron spectra outside the shielding of accelerators with openings. The analysis of these "soft"

spectra does not allow to make any particular conclusions about regularities in their formation due to large errors of unfolding, but all "soft" spectra are of the same behaviour.

For the further analysis of spectra formation outside the shielding of accelerators it is necessary to reduce the uncertainty of the unfold spectrum. It can be achieved in two ways. The first is to increase the measurement information, i.e. to use additional detectors. The second way is to investigate and consequently take into account new *á priori* information about the form of the unfolding spectra.

#### REFERENCES

- (1) WEINSTEIN, M.S. et al. Preprint, HASL-223 (1970)
- (2) THOMAS, R.H. Neutron Monitoring for Radiation Purposes, vol.1, IAEA, Vienna, 327 (1973)
- (3) ALEINIKOV, V.E., GERDT, V.P., KOMOTCHKOV, M.M. Neutron Monitoring for radiation Protection Purposes, vol.1, IAEA, 31 (1973)
- (4) ALEINIKOV, V.E., GERDT, V.P., KOMOTCHKOV, M.M. Trudy IV Vsesoiuznogo sovescania po uskoriteliam zariajennyh chastic Nauka, M., 1975. Preprint JINR, P16-8176, Dubna, 1976
- (5) TURCHIN, V.F., KOZLOV, V.P., MALKEVICH, M.S. Uspechi fiz. nauk, 102, 345 (1970)
- (6) TUROVCEVA, L.S., TURCHIN, V.F. Preprint IPM, 30, Moskva, 1975.
- (7) TUROVCEVA, L.S., Reshenie obratnykh nekorrektnykh zadach metodom statisticheskoi reguljarizacii. Preprint IPM, Moskva, 1975
- (8) ALEINIKOV, V.E., GERDT, V.P., KOMOTCHKOV, M.M. Preprint JINR, P16-9870, Dubna, 1976
- (9) ISRAEL, H.I., COCHRAN, D.R.F. In Proc. Second Intern. Conf. on Accelerator Dosimetry and Experience, Stanford, California, 341 (1969)
- (10) GELFAND, E.K., MANKO, B.M., SEROV, A.J., SYCHOV, B.S. Trudy RTI, 22, 242 (1975)

## NEUTRON SPECTRA FROM A SAGITTAIRE MEDICAL ACCELERATOR\*

G. R. Holeman<sup>#</sup>, K. W. Price<sup>#</sup>, L. P. Friedmant, and R. Nath<sup>o</sup><sup>#</sup>-Health Physics Division, Yale University, New Haven, Conn., 06520, U.S.A.<sup>+</sup>-Health Physics, Yale-New Haven Hospital, New Haven, Conn. 06504, U.S.A.<sup>o</sup>-Department, Therapeutic Radiology, Yale University, School of Medicine, New Haven, Conn., 06510, U.S.A.INTRODUCTION

The THERAC 40/Sagittaire is an electron linear accelerator designed for radiotherapy purposes and delivers electrons between 7 and 32 MeV and 25 MeV x-rays. Dosimetry of the mixed photon-neutron field is of interest both from the patient dose and the occupational shielding design considerations. One of the outstanding problems in neutron measurements has been the unavailability of reliable neutron energy spectra at various locations in the vicinity of the treatment area. This results in uncertainties in assigning appropriate quality factors. Previous studies of the neutron fields from accelerators of this type (1,2) have used silicon diodes which require large exposures and thus are time consuming. In these referenced studies, conversion of neutron fluxes to absorbed doses were calculated utilizing a conversion factor based on a Cf-252 neutron spectrum. In addition, a quality factor of 10 was assumed. The technique used in this work may be applied at significantly lower photon doses with adequate sensitivity for neutrons outside of the treatment field. A neutron energy spectrum is obtained and individual maximum dose conversion factors and appropriate quality factors are applied to each energy group and summed, yielding a total neutron dose equivalent.

METHODS

A Bonner Spectrometer (3) was used as the method of measuring photoneutrons in this work. It consisted of the bare detector, a 0.03 in. thick cadmium cap, and six polyethylene moderating spheres (2,3,5,8,10 and 12 in. in diameter). The detector consisted of a set of four lithium fluoride thermoluminescent dosimeter chips, two Harshaw TLD-600 ( ${}^6\text{LiF}$ , ~ 95.6%  ${}^6\text{Li}$ ) and two Harshaw TLD-700 ( ${}^7\text{LiF}$ , ~ 99.99%  ${}^7\text{Li}$ ). The chips measured  $1/8 \times 1/8 \times 0.035$  in. The TLD-700 and TLD-600 are both sensitive to photons, while the TLD-600 is many times more sensitive to thermal neutrons than is the TLD-700. Thus, the photon contribution to the TLD-600 may be subtracted, leaving only a thermal neutron response. A set of four TLD chips is placed at the center of each sphere and measures thermal neutrons produced as a result of moderation of the incident neutron spectrum.

The method of determining the neutron spectrum from this type of spectrometer by an iterative technique has been discussed elsewhere by O'Brien (4). The response matrix which relates the incident neutron energy in a given detector-sphere geometry to thermal neutrons at the sphere center, was based on calculations (5,6,7). In order to compute absorbed dose and dose equivalent from a neutron flux measurement, the maximum dose and dose equivalent conversion factors utilized were those of the Health and Safety Laboratory (6,7). This spectrometer has been thoroughly evaluated at the Yale Health Physics Division (8) using known test spectra and was found to be a reliable low resolution spectrometer system.

The thermoluminescent dosimeters (TLD-600 and TLD-700) were calibrated for photon response using 0.662 MeV photons (Cs-137) and 6 MV x-rays. The TLD were also calibrated for thermal neutron response using a calibrated plutonium beryllium (PuBe) neutron source. It was observed that the maximum deviation of the neutron sensitivities of all the chips may vary as much as 7% from the mean for the TLD-700 and 10.7% for the TLD-600. Gamma sensitivities for the TLD-700 varied as much as 23%, and 25% for the TLD-600. The percent standard deviations of the aggregate neutron sensitivities were 3.0%

\* This work supported in part by NCI Grant No. CA-16359.

for the TLD-700 and 4.7% for the TLD-600. Gamma sensitivities had standard deviations of as much as 13.2% for the TLD-700 and 13.8% for the TLD-600. Therefore, each chip was individually calibrated for neutron and photon sensitivity to correct for this variation. The neutron spectrum from PuBe is well known, with an average neutron energy of 4.1 MeV (9). Each individual chip was numbered and placed at the center of each sphere, used bare, and covered with cadmium. Each detector assembly was exposed to the PuBe source, and a calibration of the system was made. This calibration was performed by forcing the iteration technique to yield a total number of neutrons equal to the known source output. The resultant neutron energy spectrum had a peak at 3.9 MeV, very near to the published average of 4.1 MeV (9).

## MEASUREMENTS

All measurements were made with the Sagittaire operating in the 25 MV photon mode. Neutron fluxes were measured for the standard field size of 10x10 cm at several distances from the beam axis. It was found that the measured neutron spectra were the same with or without a phantom in the beam. Therefore, a phantom was not placed in the beam for measurements of neutron spectra and dose rates in the treatment room. Neutron spectra measurements were made inside and outside the shielding door of the treatment room. In addition, measurements were made at various perpendicular distances from the beam axis at the height of the isocenter. The data for the neutron spectrum just inside the shielding door were accumulated for 2997 photon rads with the beam directed into the floor. The data for the neutron spectra outside the door were based on integrated patient photon doses of 85,479 and 26,770 rads. Figure 1 is a comparison of a spectrum measured inside the shielding door and two separate measurements of spectra outside the door. Although the neutron spectra measurements suffer from poor energy resolution, it is apparent that neutron intensities and doses are reduced in passing through the door, and the neutron spectrum "hardens" to various degrees. The two measured spectra outside the door have the same general shape but are quantitatively different. This variability results from the fact that for these measurements, the spectrometer was exposed to the neutron field over a week when the accelerator was being operated under normal conditions. Since the gantry angle, field size and other irradiation parameters vary dramatically, it is not surprising that the measured spectra are slightly different in two separate runs.

Measurements inside the treatment room were taken at perpendicular distances of 0.5, 1.2 and 4.8 meters from the beam axis. The resulting neutron spectra obtained are shown in Figure 2. The integrated fast neutron flux varies with the inverse square law when the distance from the target is used rather than the distance from the beam axis. This would indicate that the major source of photoneutrons is the target and collimator assembly. Slow fluxes do not vary significantly with the distance from the beam axis and contribute only a small fraction to the total neutron dose equivalent throughout the treatment room.

## DISCUSSION

Each neutron spectrum measured was converted to absorbed dose rate and dose equivalent rate by utilizing maximum values of fluence to dose conversion factors (7) and the appropriate quality factor at each energy interval of the spectrum. The resultant total absorbed dose rates (rad/min) at various locations within and outside the treatment room are given in Table I. As would be expected, the neutron doses decrease as one moves away from the beam axis. The total neutron dose equivalent outside the shielding door varied from  $1.04 \times 10^{-7}$  rem/min to  $1.39 \times 10^{-8}$  rem/min of beam "on" time. In all measurements the neutron doses were a small fraction of the photon on axis treatment dose rate of 400 rad/min..

Table I also presents the neutron dose rates for slow ( $<0.1$  KeV), fast ( $>0.1$  KeV), and total. The slow neutron dose rate is uniform throughout the room. The fast neutron dose rate follows the inverse square law when compared to distance from the target.

Previous studies (9) indicate a calculated quality factor of 7.3 for PuBe neutrons. Using PuBe neutrons and TLD as the detector in the Bonner Spectrometer, a quality factor of 7.3 was inferred from measurements at a source to detector distance of 50 cm. This good agreement between PuBe neutron quality factors provided confidence in determination of average quality factors for the accelerator produced neutrons. Table I presents the quality factors as they vary with distance from the Sagittaire target. At 4.8 meters the quality factor and dose rates are high due to the influence of backscatter from the wall.

Wilenzick et al (1) have measured the fast neutron absorbed dose with silicon diodes. The results are plotted as the ratio of neutron rad/min to central axis photon rad/min versus distance from the beam axis. In another series of measurements, silicon diodes were placed at various distances from the beam axis and neutron rad doses determined (2). Plotted in Figure 3 are the results of both of the above mentioned references, along with the dose determinations of the present work. The ratios of the neutron absorbed dose to the central axis photon absorbed dose are plotted versus the perpendicular distance from the beam axis. Values outside of the direct beam vary from the other published data. This is most likely due to the dose conversion factors used in converting from neutron fluence to dose. In using Cf-252 as a dose calibration source, an average neutron energy of 2.35 MeV exists (10). In the present work, individual maximum dose conversion factors were applied to each energy group of the unfolded neutron spectra. In all cases the neutron spectra peaked at less than 1 MeV neutron energy. This would yield a somewhat lower value of the total neutron doses, especially as the distance from the beam axis is increased. However, it was felt that agreement was good in light of the poor resolution of the spectrometer system.

#### REFERENCES

- (1) R.M.Wilenzick, P.R.Almond, G.D.Oliver, Jr. and C.E.DeAlmeida, "Measurements of Fast Neutrons Produced by High-Energy X-Ray Beam of Medical Electron Accelerators", *Phy. Med. Biol.* 18 (1973) 393.
- (2) J.R.Marbach, "Neutron Leakage From the Sagittaire Linear Accelerator at the University of Indiana at Indianapolis" (Personal Communication) (1975).
- (3) R.L.Bramblett, R.I.Ewing and T.W.Bonner, *Nucl. Instrum. Meth.* 9 (1960)1.
- (4) K.O.Brien, R.Sanna and J.McLaughlin, First Symposium on Accelerator Radiation Dosimetry and Experience USAEC-Conf-651109 (1965) 346.
- (5) S.A.McGuire, A Dose Monitoring Instrument for Neutrons from Thermal to 100 MeV, USAEC Report LA-3435 (1965).
- (6) J.E.McLaughlin, ERDA HASL (Personal Communication) ( 1968).
- (7) M.S.Weinstein, K.O'Brien and P.Rajnal, Procedures for Estimating the Errors in Neutron Spectra from Bonner Multisphere Measurements USAEC HASL Report No. Tm-69-4 (1969).
- (8) G.L.Watkins and G.R.Hoeman, "The Evaluation of an Iterative Technique's Use in Unfolding Neutron Spectra Data", *Health Physics* 15 (1968) 535.
- (9) D.Nachtigall, "Average and Effective Energies, Fluence-Dose Conversion Factors and Quality Factors of the Neutron Spectra of Some ( $\alpha,n$ ) Sources", *Health Physics* 13 (1967) 213.
- (10) Californium-252, Its Use and Market Potential, USAEC (1969).

SAGITTAL NEUTRON DOSE RATES AND SPECTRA QUALITY FACTORS							
Neutron Dose Rates*							
W. Range	Beam Size	Rad/min			R <sub>eq</sub> /min		Quality Factor
From Target to Detector		Slow	Fast	Total	Slow	Fast	
1.16	10x10 cm	8.100x10 <sup>-3</sup>	9.830x10 <sup>-2</sup>	1.049x10 <sup>-1</sup>	1.905x10 <sup>-3</sup>	8.371x10 <sup>-1</sup>	8.563x10 <sup>-1</sup>
1.64	15x10 cm	8.28x10 <sup>-3</sup>	8.07x10 <sup>-2</sup>	8.89x10 <sup>-2</sup>	2.040x10 <sup>-3</sup>	6.09x10 <sup>-1</sup>	6.89x10 <sup>-1</sup>
2.24	10x10 cm	8.22x10 <sup>-3</sup>	3.589x10 <sup>-2</sup>	4.391x10 <sup>-2</sup>	1.98x10 <sup>-3</sup>	2.878x10 <sup>-1</sup>	3.07x10 <sup>-1</sup>
4.8	10x10 cm	6.12x10 <sup>-3</sup>	1.123x10 <sup>-1</sup>	1.735x10 <sup>-1</sup>	1.63x10 <sup>-3</sup>	9.818x10 <sup>-1</sup>	1.142x10 <sup>-1</sup>
Inside Accelerating Tank	10x10 cm	1.892x10 <sup>-3</sup>	1.213x10 <sup>-1</sup>	3.163x10 <sup>-1</sup>	5.036x10 <sup>-4</sup>	9.332x10 <sup>-1</sup>	1.41x10 <sup>-1</sup>
Outside Accelerating Tank							
55,479 rad	Variable	8.940x10 <sup>-6</sup>	1.307x10 <sup>-2</sup>	4.201x10 <sup>-2</sup>	2.49x10 <sup>-7</sup>	2.716x10 <sup>-1</sup>	5.990x10 <sup>-1</sup>
73,773 rad	Variable	1.610x10 <sup>-7</sup>	3.623x10 <sup>-3</sup>	6.232x10 <sup>-3</sup>	7.330x10 <sup>-7</sup>	6.192x10 <sup>-1</sup>	6.98x10 <sup>-1</sup>
2.0		3.44x10 <sup>-11</sup>	5.32x10 <sup>-7</sup>	5.36x10 <sup>-7</sup>	1.35x10 <sup>-11</sup>	5.85x10 <sup>-1</sup>	6.6x10 <sup>-1</sup>

\* based on Maximum Tube Conversion Coefficients. † based on 400 phasings per min at 100 meters from target.

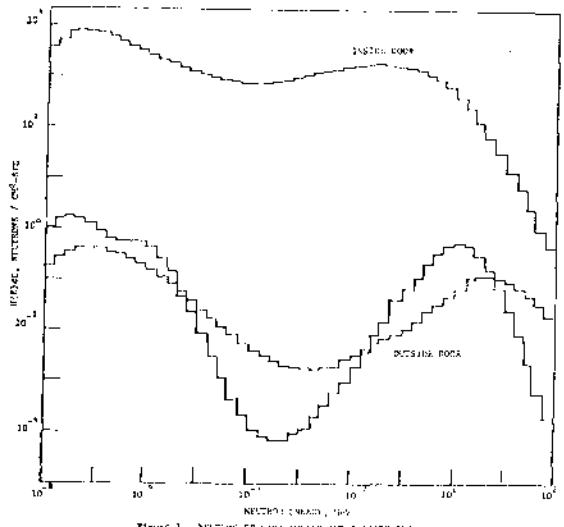

Figure 1. NEUTRON SPECTRA INSIDE AND OUTSIDE STORAGE TANK

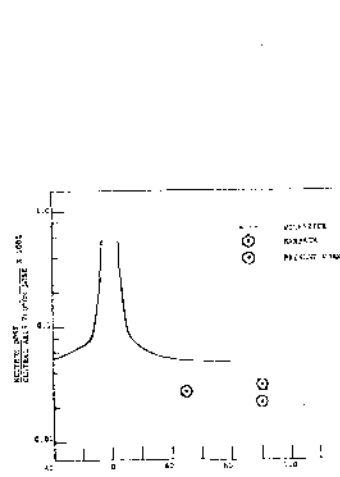

Figure 3. RATIO OF NEUTRON DOSE TO FAST NEUTRON DOSE

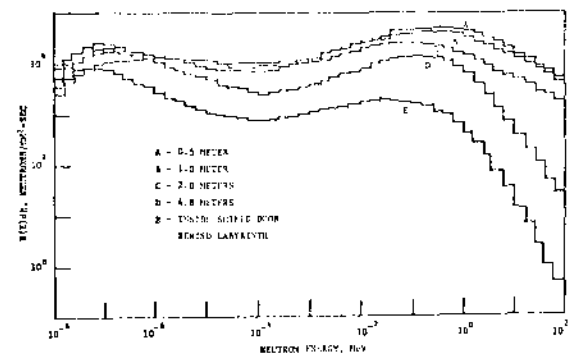

Figure 2. NEUTRON SPECTRA AT VARIOUS CIRCULAR DISTANCES FROM THE BEAM AXIS

MEASUREMENTS AND CALCULATIONS OF NEUTRON SPECTRA  
FOR IRRADIATION OF A PHANTOM

V.E. Aleinikov, V.P. Bamblevsky, M.M. Komochkov  
Joint Institute for Nuclear Research, Dubna, USSR  
B. Dörschel, K. Prokert, V. Schuricht, G. Streubel  
Technical University Dresden, GDR

## 1. INTRODUCTION

For the interpretation of neutron detector readings in order to determine the absorbed dose in the human body it is necessary to know the spectral distribution of the neutron fluence. The various reactions of the neutrons with the nuclei in the body change the incident spectrum. Therefore, the possibility of an exact neutron dosimetry depends on the determination of the neutron spectrum in the body or in a phantom.

## 2. RESULTS OF EXPERIMENTAL DETERMINATION OF NEUTRON SPECTRA

Investigations were carried out for the following spectra:

- spectrum of the incident neutrons,
- spectrum at the surface of a water phantom (elliptical cross section with axis of 24 and 36 cm, respectively, and a height of 60 cm), and
- spectra in this phantom at depths of 4 and 12 cm, respectively.

The phantom was irradiated in the neutron beam (radius 20 cm) of the fast impulse reactor IBR-30 (1) of the JINR Dubna at the 10 m base in channel 6 (power 15 kW, impulse frequency 5 Hz, moderator 40 mm H<sub>2</sub>O). The beam vertically struck the centre of the phantom parallel to the small axis.

The spectra determinations based on the activation method(2). For neutron energies  $E > 0,7$  MeV all spectra were determined by an iteration method (3,4) using activation rates of threshold detectors. The spectrum of the incident fast neutrons also was calculated from these values by unfolding with the aid of the statistical regularization method (5). Results are given in Fig. 1. The spectra of intermediate neutrons ( $1,46$  eV  $< E < 10^4$  eV) result from the flux densities measured at different resonance energies using a set of 11 resonance detectors (In,

Dy, Au, Sm, W, La, Mn, Cu, Y, Na, Cl). The spectrum of thermal neutrons ( $E < 0,2$  eV) was determined from the activation rates of Au detectors. In the range between the three groups (fast, intermediate and thermal) the spectra must be interpolated. The spectrum of the incident neutrons also was determined by the method of statistical regularization using activation rates of In detectors which were irradiated in five polyethylene moderator spheres with diameters between 2 and 12 1/2 inches (6).

The complete spectrum of the incident beam measured with different methods is demonstrated in Fig. 2. For comparison also a spectrum is given measured by the time-of-flight method (1). Fig. 3 gives spectra at the surface of the phantom and inside the phantom. One can see the influence of the phantom on the neutron flux density and the energy distribution. As the result of scattering processes the part of thermal neutrons has strongly increased. A re-increasing of the fast neutron fraction is remarkable in the depth of 12 cm.

### 3. RESULTS OF THEORETICAL INVESTIGATION OF NEUTRON SPECTRA

Theoretical investigations of neutron fields at the surface and inside the described phantom were performed on the base of a three-dimensional Monte-Carlo code assuming a similar incident neutron spectrum. The calculations show that with increasing depth in the phantom the fraction of thermal neutrons increases and for intermediate and fast neutrons the fraction of the low energy part decreases.

If the energy distribution of the intermediate neutrons is described by an  $1/E^\alpha$ -spectrum, the parameter  $\alpha$  decreases with increasing depth in the phantom (Fig. 4). In the range of fast neutrons the mean energy  $\bar{E}$  remarkably increases for depths up to 14 cm and then slightly decreases (Fig. 4). This effect can be based on the increasing influence of fast neutron reactions on the field composition in depths above 14 cm.

A comparison between the calculated and measured spectrum of reflected neutrons is given in Fig. 3 which shows a good agreement of both curves.



#### 4. CONCLUSIONS

The experimental and theoretical investigations have been shown that the spectrum of the incident neutrons and the spectra at the surface or in several depths of the phantom are very different, because the various interactions of the neutrons depend in a different manner on the neutron energy. Therefore, only the knowledge of the neutron spectrum permits to calculate the fluence and the absorbed dose from a detector reading. It is then possible to determine the absorbed dose for interesting depths in a phantom or in the human body.

#### REFERENCES

- (1) GOLIKOV, V.V., et al., Preprint P2-4985, JINR, Dubna 1971
- (2) STREUBEL, G., et al., Kernenergie 20 (1977) 49
- (3) ARCIPIANI, B., et al., Nucl. Instr. Meth. 108 (1973) 301
- (4) DIERCKX, R., Nucl. Instr. Meth. 105 (1972) 1
- (5) ALEINIKOV, V.E., et al., Preprint P16-9621, JINR, Dubna 1976
- (6) ALEINIKOV, V.E., et al., Preprint P16-9123, JINR, Dubna 1975
- (7) DÖRSCHEL, B., Kernenergie 19 (1976) 161

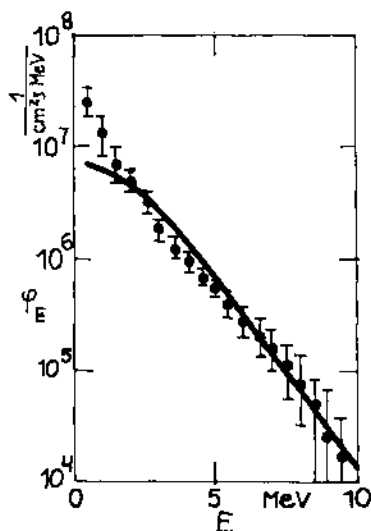

FIG. 1. Fast neutron spectrum  $\phi_E$  of IBER-30  
 — iteration method (2)  
 - - - statistical regularization method (5)

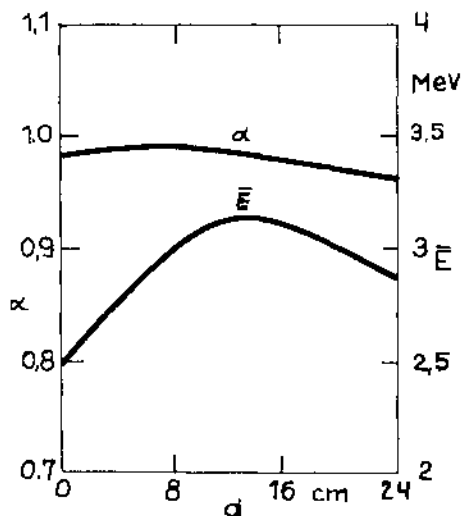

FIG. 4. Spectrum parameter  $\alpha$  and mean energy  $\bar{E}$  of fast neutrons  $\bar{E}$  at several depths  $d$  inside the phantom (7)

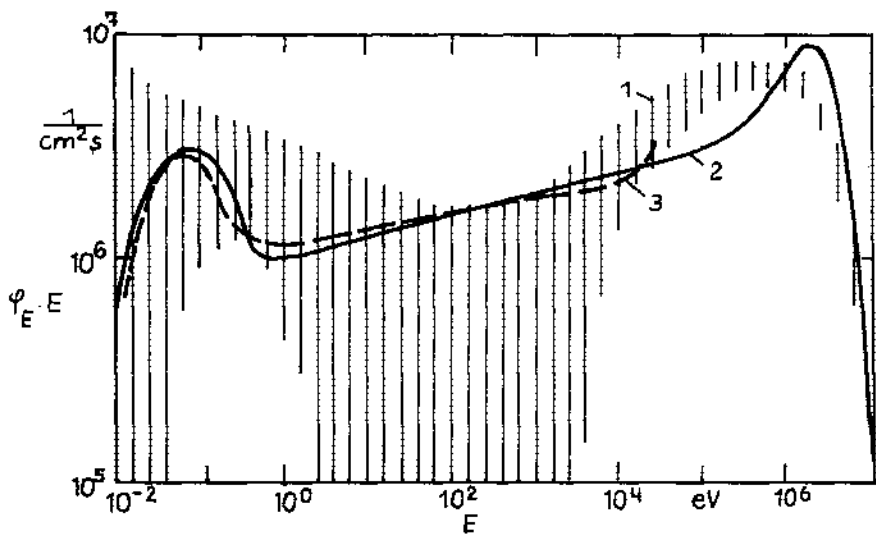

FIG. 2. Neutron spectrum  $\varphi_E$  (multiplied by E) of IBR-30

- 1 - results of the JINR
- 2 - results of the TU (2)
- 3 - results after GOLIKOV (1)

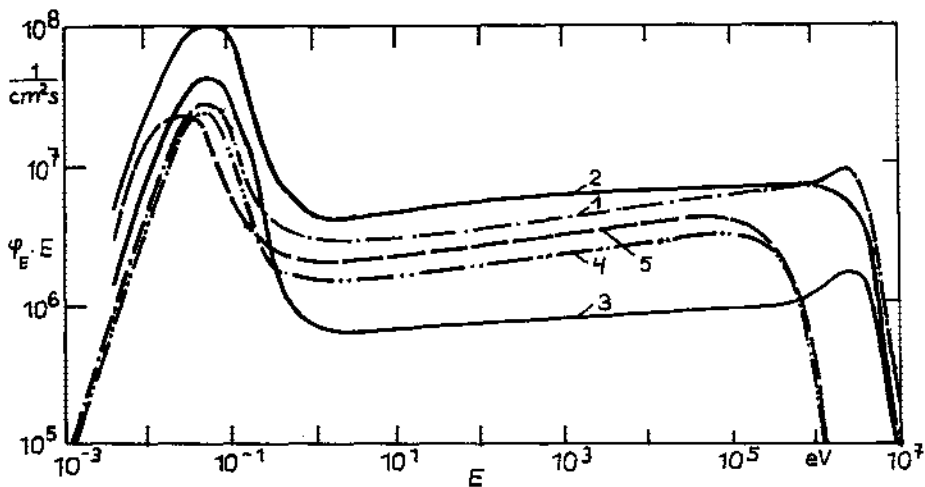

FIG. 3. Neutron spectra  $\varphi_E$  (multiplied by E) for irradiation of a phantom at IBR-30

- 1 - at the surface of the phantom
- 2 - inside the phantom, depth 4 cm
- 3 - inside the phantom, depth 12 cm
- 4 - reflected neutrons
- 5 - reflected neutrons (calculated (7))

SPECTROMÉTRIE NEUTRONIQUE PAR SCINTILLATION LIQUIDE :  
 PROBLÈMES POSÉS PAR L'INTERPRÉTATION DU SPECTRE EXPÉRIMENTAL

V. D. Nguyen<sup>\*</sup>, M. Chemtob<sup>\*</sup>, J. J. Broers<sup>\*\*</sup>, B. Hogeweg<sup>\*\*</sup>,  
 B. Davigne<sup>\*</sup>, R. Scullé<sup>\*</sup>

## 1. INTRODUCTION

Le processus physique prédominant dans la détection des neutrons par un scintillateur organique est la diffusion élastique des neutrons sur les protons. Cette diffusion donne naissance à un spectre continu de protons de recul qui, à leur tour, délivrent par scintillation une distribution d'impulsions lumineuses accessible expérimentalement. La connaissance de la fonction de réponse en énergie du scintillateur permet de convertir cette distribution des impulsions en spectre énergétique des protons de recul, et d'en déduire ensuite le spectre neutronique incident.

La réponse en énergie du scintillateur aux protons de recul n'est pas linéaire ; par contre, elle est linéaire pour les électrons issus de la diffusion Compton produite dans le scintillateur par les rayonnements gamma. Cette dernière réponse linéaire rend possible l'étalonnage en énergie de l'analyseur, à l'aide de sources gamma connues.

Ainsi, pour déduire le spectre des protons de recul, à partir de la distribution des impulsions, il faut établir au préalable la relation entre les énergies de protons et des électrons donnant des impulsions lumineuses égales.

Cette étude n'aborde pas les problèmes posés par la seconde diffusion des neutrons sur les noyaux d'hydrogène, par les effets de paroi, et par la production des noyaux lourds de recul. Elle considère seulement l'incidence de la relation qui permet de calculer l'énergie du proton à partir de l'énergie de l'électron sur la détermination du spectre neutronique et sur le calcul du kerma à partir de ce spectre.

## 2. TECHNIQUE DE MESURE

La technique de mesure utilisée est celle, devenue classique, de la discrimination des formes des impulsions délivrées par un scintillateur organique NE 213 suivant le type des particules incidentes (1). La durée qui sépare le début et la fin de l'impulsion est convertie en signal analogique. La distribution de ces signaux est répartie en deux groupes, correspondant respectivement aux impulsions produites par les neutrons et par les gamma. L'utilisation d'un seuil permet d'isoler le groupe neutron, et la mise en coïncidence entre les signaux de la voie "temps" avec les signaux linéaires sortant de la onzième dynode du photomultiplicateur donne une discrimination correcte neutron - gamma.

La gamme d'énergie des neutrons explorée par cette technique avec un scintillateur cylindrique NE 213 de 5 x 5 cm s'étend de 0,5 MeV à 18 MeV environ.

\* Département de Protection - Service de Protection Sanitaire -  
 Commissariat à l'Énergie Atomique - BP n° 6 - 92260 FONTENAY AUX ROSES  
 (France)

\*\* R & P - Institutes of the Organisation for Health Research -  
 Radiobiological Institute - 151 Lange Kleiweg RICSWICK 2.N. (Pays-Bas)

### 3. METHODE DE TRAITEMENT

Les distributions expérimentales des impulsions ainsi obtenues représentent les impulsions lumineuses provenant des protons de recul et des particules alpha produites par les réactions  $^{12}\text{C}(n, \alpha)^9\text{Be}$  et  $^{12}\text{C}(n, n')^9\text{C}$ . Cette présente étude néglige les perturbations provenant des alpha.

La méthode de traitement comprend trois étapes.

#### 3.1. Conversion du spectre des impulsions en spectre protonique

La distribution des impulsions est convertie en distribution énergétique des protons, en utilisant la relation entre l'énergie d'un électron et celle d'un proton donnant des impulsions lumineuses égales. Cette relation est ajustée analytiquement sous deux formes différentes.

- Forme exponentielle couramment utilisée :  $E_e = \alpha \frac{E_p^3}{\beta}$

dont les valeurs de  $\alpha$  et de  $\beta$  sont égales à :

neutrons d'environ 5 MeV :  $\alpha = 0,1439$        $\beta = 1,666$   
neutrons d'environ 15 MeV :  $\alpha = 0,2162$        $\beta = 1,883$

- Forme polynomiale :  $E_e = E_p (A_3 \frac{E_p^2}{\beta} + A_2 \frac{E_p}{\beta} + A_1) + A_0$

de 0 à 14 MeV

$$A_3 = 7,186 \cdot 10^{-3}$$

$$A_2 = 1,642 \cdot 10^{-2}$$

$$A_1 = 0,188$$

$$A_0 = 0$$

de 14 à 18 MeV

$$A_3 = 0$$

$$A_2 = 0$$

$$A_1 = 0,6722$$

$$A_0 = 1,2115$$

Le raccordement entre ces deux parties doit être fait de telle façon que la dérivée soit constamment continue.

#### 3.2. Lissage et dérivation du spectre protonique

Cette étape consiste en un traitement classique de données.

#### 3.3 Conversion en spectre neutronique

La fonction dérivée du spectre protonique est convertie en spectre neutronique par la fonction de conversion de TOMS (2), (3), (4). Cette fonction tient compte de l'efficacité de détection des neutrons, de la correction des effets de paroi et de la double diffusion des neutrons sur les noyaux d'hydrogène.

### 4. RESULTATS

Les mesures ont été faites dans des faisceaux collimatés de neutrons mono-énergétiques de 5,3 MeV et 14,8 MeV. Pour chacune de ces énergies, le scintillateur est placé dans l'air en espace libre, et ensuite dans l'eau à des profondeurs de 10 cm et de 20 cm.

La méthode de traitement est identique pour tous les spectres sauf pour la conversion de l'énergie électron en énergie proton (Figure 1). Dans le tableau 1, les résultats de la colonne (E) sont obtenus par la rela-

tion exponentielle et ceux de la colonne (P) par la relation polynomiale.

Figurent également dans ce tableau, les nombres de protons calculés sur les spectres protoniques pendant la durée des mesures, les fluences neutroniques et les doses kerma (5) calculées sur les spectres neutroniques. Les nombres totaux de protons sont identiques pour les deux modes de conversion (E) ou (F), ce qui est évident puisqu'ils ont été obtenus à partir des mêmes distributions d'impulsions ; seules leurs répartitions énergétiques diffèrent. La répercussion de ces différences est constatée dans les valeurs des fluences neutroniques et des doses kerma. Elle est d'autant plus importante que la gamme d'énergie considérée est plus étendue; l'écart en terme de dose (kerma) est supérieure à 20 % pour les neutrons de 14,8 MeV, alors qu'il reste inférieur à 5 % pour les neutrons de 5,3 MeV.

## 5. CONCLUSION

Il semblerait donc plus intéressant d'adopter la méthode d'ajustement polynomial de la relation de conversion d'énergie électron en énergie proton. Elle évite non seulement la distorsion sur les spectres obtenus, mais aussi elle rend plus simple l'exploitation des données.

## REFERENCES

- (1) COLVETI, R.D., MARINO, S.A., RODGERS, R.C. NYO-2740-8 (1971).
- (2) JONES, D.W., ELAINE TOMS, M., NPL 7324 (1971)
- (3) ELAINE TOMS, M., IAEA Transactions on Nuclear Science, NS 17, 3 (1970)
- (4) BENEZECH, G., et coll., communicat. privée, DSX/SESTR, Cadarache (1974)
- (5) CASWELL, R.S., COYNE, J.J., RANDOLPH, M.L., Basic Physical Data for Neutron Dosimetry, ECR 5629e, (1976).

Point de mesure	Nombre de protons ( $10^6$ )		Fluence neutronique ( $10^6$ n.cm <sup>2</sup> )		Kerma ( $10^{-3}$ rad)		Ecart en % sur kerma
	(E)	(F)	(E)	(F)	(E)	(F)	
Faisceau collimaté 5,3 MeV							
dans l'air	4,62	4,63	1,46	1,52	6,70	6,97	- 3,9
10 cm d'eau	3,84	3,85	1,21	1,20	5,49	5,48	0,2
20 cm d'eau	1,55	1,57	0,47	0,45	2,11	2,03	4
Faisceau collimaté 14,8 MeV							
dans l'air	5,53	5,53	2,98	2,44	19,98	15,84	26,2
10 cm d'eau	7,50	7,51	3,56	3,10	23,56	19,66	19,8
20 cm d'eau	7,43	7,43	3,50	3,03	22,87	18,95	20,7

TABLEAU 1 - Résultats comparés des deux méthodes

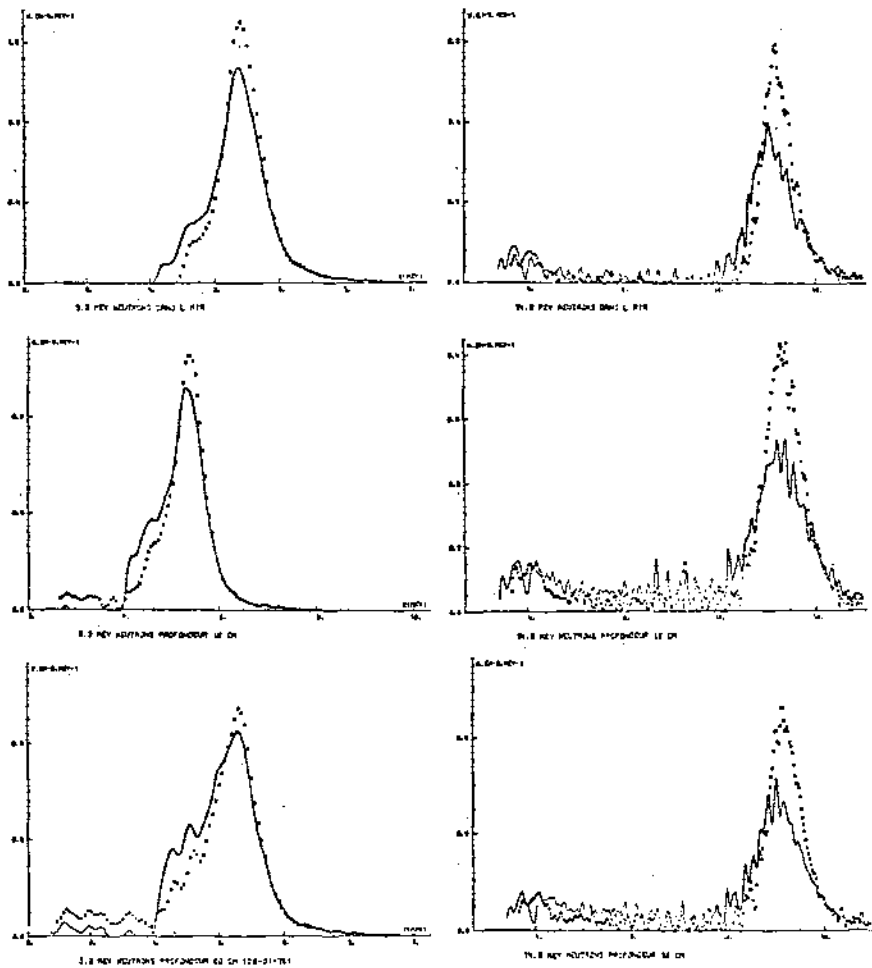

Figure 1 - Spectres neutroniques .... méthode (S) ——— méthode (P)

COMPARATIVE STUDIES OF  
PLUTONIUM INVENTORIES IN SOILS AND MARINE SEDIMENTS

Anker Aarkrog  
Research Establishment Risø  
DK-4000 Roskilde, Denmark

### 1. INTRODUCTION

The rapid growth in the worldwide use of nuclear energy and concern for the safety of man and his environment have led in recent years to increasing interest in the long-lived transuranium nuclides. Plutonium is of special importance in this context because, compared to other transuranics, it is already created in substantial amounts in present reactors, and in breeder reactors it will occur in large quantities. Plutonium is already present in the environment. The global inventory from worldwide fallout has thus been estimated at  $(325 \pm 36)$  kCi  $^{239,240}\text{Pu}$  (1); and Windscale has discharged approx. 10 kCi into the Irish Sea (2). Minor amounts of  $^{239,240}\text{Pu}$  have been released to local environments as a result of the nuclear-weapon incidents at Palomares in Spain and at Thule in Greenland.

The present study estimates the plutonium inventories at Thule from the B-52 accident in 1966 and in Danish soils and sediments from nuclear weapons testing. A further aim of the study was to compare the vertical distributions of  $^{239,240}\text{Pu}$  and  $^{137}\text{Cs}$  in soils and sediments.

### 2. MATERIAL AND METHODS

The Thule samples consisted of 3 cm thick core samples collected by a 135 mm diameter coring tube (Model EAPS) out to a distance of 16 km from the point of impact where the B-52 plane crashed (3). The EAPS was also used to collect sediment samples from inner Danish waters. The soil samples were collected down to a depth of 50 cm from locations distributed throughout Denmark (4). All common types of Danish soil were represented. Uncultivated as well as cultivated soils were collected from each location. The uncultivated samples were analyzed in depth sections of 0-10 cm, 10-20 cm, 20-30 cm and 30-50 cm, and the cultivated in 0-20 cm (the ploughing layer), 20-30 cm and 30-50 cm sections.

The radiochemical plutonium analysis followed the classical procedure (5) adapted to 10 g. aliquots of dried material. Cesium-137 was measured by Ge(Li)- $\gamma$ -spectroscopy.

### 3. RESULTS AND DISCUSSION

The vertical distribution in soils as well as in sediments of  $^{239,240}\text{Pu}$  and  $^{137}\text{Cs}$  was with good approximation described by exponential regression lines. Similar observations have been made for the contamination of sediments in the Irish Sea (2) and of a single sample of sandy loam soil from the USA (6). The exponential distribution facilitated the estimates of the total integrated activity amounts in the soil and sediment columns as:

$$A \int_0^{\infty} e^{-kx} dx = \frac{A}{k} \quad (x: \text{sample depth})$$

### 3.1. Estimate of the plutonium inventory at Thule

The horizontal distribution of the Pu-activity at Thule followed an exponential expression:

$$\text{mCi } ^{239,240}\text{Pu km}^{-2} = 460 e^{-0.28R} \quad (R: \text{distance in km from point of impact})$$

Taking land area into consideration, the inventory in the marine sediments at Thule was estimated at 25-30 Ci  $^{239,240}\text{Pu}$ . Table 1 shows that the half-depth of the activity was constant (~ 2 cm) out to a distance of 10 km from the point of impact, whereafter it increased and approached the half-depth in fallout-contaminated sediments (~ 5 cm). As the contamination at Thule is the result of a single release of plutonium and not, as is the case for fallout Pu, of several releases distributed over decades, it was expected that the half-depths would differ as observed.

Distance in km from point of impact	Regression equation $\text{mCi } ^{239,240}\text{Pu km}^{-2} \text{ cm}^{-1}$	Number of locations	Integrated mean deposition ( $d \rightarrow \text{cm}$ ) $\text{mCi } ^{239,240}\text{Pu km}^{-2}$
16 - 17	$0.5 e^{-0.2 d}$	2	2.5
9 - 11	$9 e^{-0.3 d}$	2	30
2 - 4	$12 e^{-0.3 d}$	6	40
0 - 1	$210 e^{-0.3 d}$	3	700

TABLE 1. The vertical distribution of  $^{239,240}\text{Pu}$  in marine sediments collected in 1974 at Thule, Greenland ( $d$  is the depth of the sample in cm). Each location was represented on average by 5 sample sections, the maximum sampling depth being 15 cm.

### 3.2. Plutonium and $^{137}\text{Cs}$ in Danish sediments and soils

Danish marine sediments contained the same amount of Pu as the uncultivated soils (Table 2). From the measurements of  $^{90}\text{Sr}$  deposition in Denmark (4), and from the observed ratio between  $^{239,240}\text{Pu}$  and  $^{90}\text{Sr}$  in nuclear weapons debris (1), the accumulated mean level in Denmark was estimated at  $1.3 \text{ mCi } ^{239,240}\text{Pu km}^{-2}$ , which is compatible with the actual observations. Cultivated soils apparently contained less  $^{239,240}\text{Pu}$  than this level. Some plutonium may thus have been removed from the arable land during the cultivation of the soil. This was unexpected as  $^{90}\text{Sr}$  and  $^{137}\text{Cs}$  were only little depleted in cultivated soils (4). Further studies are, however, necessary before any firm conclusions may be drawn. It appeared that the penetration of plutonium was greater than that of  $^{137}\text{Cs}$  in sediments as well as in soils. This agrees with the observations of other authors (2), (6). The half-depths of Pu and  $^{137}\text{Cs}$  were apparently less in sediments than in soil samples. This may be an artifact, because the HAPS corer used for the sediments only works in soft materials, where the penetration depth of the radionuclides may be less as a consequence of a higher ion exchange capacity than that, e.g., of sandy soils.



Sample type	Nuclide	Regression equation $\text{mCi km}^{-2} \text{ cm}^{-1}$	Number of locations	Integrated mean deposition ( $d \rightarrow \infty$ ) $\text{mCi km}^{-2}$
Marine Sediments from inner Danish waters	$^{239,240}\text{Pu}$	$0.2 e^{-0.15 d}$	5	1.3
	$^{137}\text{Cs}$	$2.4 e^{-0.18 d}$		15
Uncultivated Danish Soils	$^{239,240}\text{Pu}$	$0.13 e^{-0.10 d}$	8	1.3
	$^{137}\text{Cs}$	$11 e^{-0.12 d}$		92
Cultivated Danish Soils	$^{239,240}\text{Pu}$	$0.07 e^{-0.09 d}$	10	0.8
	$^{137}\text{Cs}$	$10 e^{-0.11 d}$		91

TABLE 2. The vertical distribution of  $^{239,240}\text{Pu}$  and  $^{137}\text{Cs}$  in marine sediments and soils collected in 1975 in Denmark (4). The sediment samples consisted on average of 4 depth sections, the maximum sampling depth being 21 cm. The samples of uncultivated and cultivated soils consisted of 4 and 3 depth sections respectively, the total sampling depth being 50 cm (8 is the depth of the sample in cm).

### 3.3. An anomalous vertical activity distribution

One of the soil samples collected from uncultivated soils in Denmark showed an unexpected distribution of the activity (Table 3). In contrast to the other samples, the radionuclide levels in this sample did not decrease with increasing sampling depth. More than half of the activity in the soil column was in fact found from 30-50 cm, and some activity may have penetrated even deeper than 50 cm. It was remarkable that the Pu/Cs and Pu/Sr ratios did not vary with sampling depth. Thus, even under anomalous circumstances, plutonium

Unit	0-10 cm	10-20 cm	20-30 cm	30-50 cm	0-50 cm
$\text{mCi } ^{239,240}\text{Pu km}^{-2}$	0.81	0.75	0.90	2.64	5.1
$\text{mCi } ^{137}\text{Cs km}^{-2}$	30	32	44	118	223
$\text{mCi } ^{90}\text{Sr km}^{-2}$	5.7	6.4	8.5	22	43
$^{239,240}\text{Pu}/^{137}\text{Cs}$	0.027	0.023	0.020	0.022	0.023
$^{239,240}\text{Pu}/^{90}\text{Sr}$	0.14	0.12	0.11	0.12	0.12

TABLE 3. The vertical distribution of  $^{239,240}\text{Pu}$ ,  $^{137}\text{Cs}$  and  $^{90}\text{Sr}$  in an anomalous sample of Danish uncultivated soil collected in Jutland in 1975 (4).

may be closely related to the  $^{137}\text{Cs}$  as well as to the  $^{90}\text{Sr}$  activity levels. The sample was taken from a meadow in a stream valley with run-off from neighbouring hillsides. This may explain why the  $^{239,240}\text{Pu}$  and  $^{137}\text{Cs}$  levels were 2-3 times higher than expected. Had the entire soil column acted as other Danish soils, we would have seen a decreasing Pu/Sr ratio with increasing sampling depth. The relatively high  $^{137}\text{Cs}$  and  $^{239,240}\text{Pu}$  concentrations at this location may be due to a selective mobilization of these nuclides, perhaps influenced by the high organic matter content in the environment. Further studies of this location may clarify the situation.

#### 4. CONCLUSION

The Pu levels in marine sediments and soil decreased exponentially with increasing sampling depth. The half-depth of the Pu deposit in sediments from a single release was approx. 2 cm. Plutonium from fallout showed a half-depth of approx. 5 cm in marine sediments and of 7 cm in soils. Sediments contained the same integrated Pu levels as untouched soils, and the levels agreed with the total deposit of plutonium, i.e.  $1.3 \text{ mCi km}^2$ . The Pu/Cs ratio was nearly constant down through the sample column, perhaps with a slight tendency to an increase with sample depth. In fallout-contaminated sediments the mean Pu/Cs ratio was approx. 0.09, in uncultivated soils 0.019, and in cultivated soils 0.01.

#### REFERENCES

- (1) HARDY, E.P., KREY, F.W. and VOLCHOK, H.L., "Global Inventory and Distribution of Fallout Plutonium", HASL-250 (1972)
- (2) HEINERINGTON, J.A., JEFFERIES, D.F. and LOVETT, M.B., "Some Investigations into the Behaviour of Plutonium in the Marine Environment", Proc. Symp. on Impacts of Nuclear Releases into the Aquatic Environment" p. 193, Olanemi, Finland (1975)
- (3) AARKROG, A., "Environmental Behaviour of Plutonium Accidentally Released at Thule, Greenland", Health Phys. (1977) In press.
- (4) AARKROG, A. and LIPPERT, J., "Environmental Radioactivity in Denmark in 1975", Risø Report 345 (1976)
- (5) TALVITTE, N.A., "Radiochemical Determination of Plutonium in Environmental and Biological Samples by Ion Exchange", Analyt. Chem. 43, 1827 (1971)
- (6) HARDY, E., "Depth Distributions of Global Fallout  $^{90}\text{Sr}$ ,  $^{137}\text{Cs}$  and  $^{239,240}\text{Pu}$  in Sandy Loam Soil in HASL-286, pI-2 (1974)

## Pu-241 AND Am-241 IN THE ENVIRONMENT

E. Holm<sup>1</sup> and R.B.R. Persson<sup>2,3</sup><sup>1</sup>International Laboratory of Marine Radioactivity, IAEA,  
Musée Océanographique, Monaco<sup>2,3</sup>Radiation Physics Department, Lasarettet, 221 85 Lund, Sweden

## 1. INTRODUCTION

The global inventory of plutonium isotopes indicates that the highest activity is represented by Pu-241 of which about 6000 kCi have been released by the atmospheric nuclear weapons tests as world-wide fallout (1,2). Another 2000 kCi of Pu-241 might be locally deposited near the test sites (3). Pu-241 is a rather short-lived beta emitting radio-nuclide which decays with a half-life of about 13 years to Am-241 which is long-lived (half-life 458 years) and is an alpha-emitter. Thus, due to the decay of fallout Pu-241 the activity of Am-241 in the environment will increase with time and reach the same activity-level as Pu-239 (2000 kCi) in about 70 years. A small amount of Am-241 is, however, present in the fabricated weapons but in the fallout it is mainly derived from the decay of Pu-241. In the effluent from nuclear reprocessing plants the Pu-241/Pu-239+240 activity ratio as well as the Am-241/Pu-239+240 activity ratio can be much higher than that in fall-out from nuclear explosions. Some observations also indicate that americium from reprocessing plants might be more easily available to biota than that originating from nuclear weapons tests (4). In the thermonuclear test explosion 'Ivy Mike' November 1952, the Pu-241/Pu-239+240 activity ratio was reported to be as high as 28 (5).

## 2. SAMPLING ANALYSIS AND MEASUREMENTS

Samples of lichen (*Cladonia alpestris*) have been collected since 1961 from the Lake Roge district in central Sweden (62.3 N, 12.4 E). A standardized technique using a frame over an area of 0.25 m<sup>2</sup> was employed. The samples had previously been analyzed for Pu-238 and Pu-239+240 (6). We have also analyzed one sediment sample collected in July 1975 from the Irish Sea, and one sediment sample collected during 1970 from the Bikini Atoll (Bravo Crater). These sediment samples had been analyzed previously for Pu-239+240 and Am-241 (4) and now about one year later also have been analyzed for Pu-241. The analysis of Pu-241 is performed by separating the Am-241 which is derived from the previously electroplated Pu-241. The Am-241 has been analyzed in the samples by ion-exchange separation in a nitric-acid/methanol medium (7). All samples were electroplated and counted with surface barrier detectors connected to a multi-channel analyzer and the activities of Pu-241 and Am-241 were corrected to the date of collection. The radiochemical yield of the radiochemical separations was monitored by addition of Pu-236 for Pu-isotopes and Am-243 or Cm-244 for Am-isotopes.

## 3. RESULTS AND DISCUSSION

The activities of Pu-241 and Am-241 lichen corrected to the date of collection during 1961-1975 are given in Fig. 1 together with the Pu-239+240 values determined previously (6). The activity concentrations of all plutonium isotopes in lichen show maxima for the period 1963-1966 of

about 4000 pCi per kg dry weight for Pu-241 and 300 pCi per kg dry weight for Pu-239+240. These maxima are caused by the larger nuclear weapons tests during 1961-1962.

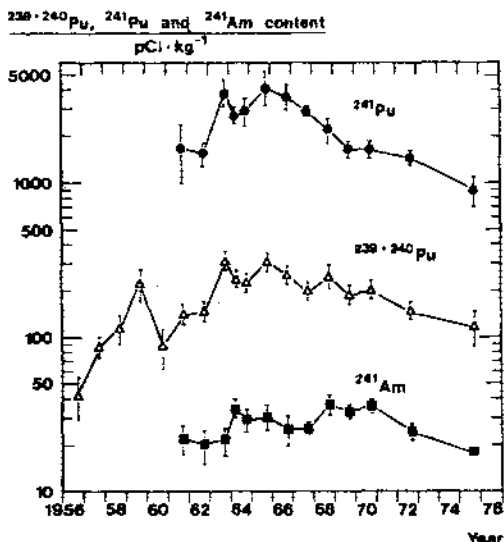

Fig. 1 The temporal variation of the activity-concentrations of Pu-241, Pu-239+240 and Am-241 in lichens collected in central Sweden.

Because most Am-241 is mainly formed in situ by the decay of Pu-241 it does not show a corresponding maximum. The maximum activity concentration of Am-241 appears much later (1968-1970) and is then about 35 pCi/kg dry weight. The activity ratios Pu-241/pu-239+240, Am-241/Pu-239+240 and Am-241/Pu-241 in lichen are presented in Fig. 2. The Pu-241/Pu-239+240 activity-ratio decreases from about 14 in 1964 to about 7 in 1975 which is mainly due to the physical decay of Pu-241. The Am-241/Pu-239+240 activity ratio shows a quite irregular pattern during the period 1961-1963 which is probably due to the presence of Am-241 in the fallout during this period. After 1967 this ratio increased to a more stable value of about 0.17 in the lichen carpet. The Am-241/Pu-241 activity ratio in lichen rises smoothly to a value of about 0.023 in 1970 but then decreased slightly. This might be an indication that Am-241 is more easily accessible in the lichen plant than Pu-241.

The biological mean residence time for plutonium in the lichen carpet was estimated previously as  $6 \pm 0.5$  years by using a simple compartment model for the area contained in the lichen carpet (1). The deposition-rate of Am-241 was estimated by using the Am-241/pu-241 activity-ratio of surface air and the Pu-241 deposition curve derived previously (1,5). For Am-241, however, one also has to take the in situ build up into consideration and the biological mean residence time for americium in the lichen was estimated as  $3 \pm 1$  years.

The activity levels and activity-ratios for sediments, lichen and global fallout are summarized in Table 1.

Environmental sample	Pu-239+240	$\frac{\text{Pu-241}}{\text{Pu-239+240}}$	$\frac{\text{Am-241}}{\text{Pu-239+240}}$	$\frac{\text{Am-241}}{\text{Pu-241}}$
Global fallout	1.0 $\pm$ 0.1*	7.0 $\pm$ 1.0	0.24 $\pm$ 0.02	0.034
Reindeer Lichen	0.12 $\pm$ 0.03***	8.0 $\pm$ 1.0	0.16 $\pm$ 0.02	0.02
Bikini sediment	83 $\pm$ 3**	8.2 $\pm$ 0.5	0.58 $\pm$ 0.02	0.077
Windscale sediment	110 $\pm$ 4***	22 $\pm$ 2	2.0 $\pm$ 0.1	0.09

(\*) nCi/m<sup>2</sup>

(\*\*\*) nCi per kg dry weight

Table 1. The activity content and various activity ratios of Pu-239+240, Pu-241 and Am-241 in various types of environmental samples. (Activity corrected to Oct. 1975).

#### REFERENCES

- (1) HOLM, E., PERSSON, R.B.R. Radiochemical studies of Pu-241 in reindeer lichens. Health Phys. (submitted Aug. 1976).
- (2) KREY, P.W., et al. "Mass isotopic composition of global fallout plutonium in soil", p. 671, Transuranium Nuclides in the Environment, IAEA, Vienna (1976).
- (3) WRENN, McD. E. "Environmental levels of plutonium and the transplutonium elements", p. 89, EPA Plutonium Standard Hearings Washington D.C., WASH-1359 (1974).
- (4) BEASLEY, T.M., FOWLER, S.W., Plutonium and Americium: Uptake from contaminated sediments by the Polychaete *Neris diversicolor*. Marine Biol. 38 (1976) 95.
- (5) THOMAS, C.W., PERKINS, R.W. "Transuranium elements in the atmosphere". Rpt. BNWL-1881, UC-48, Battelle Pacific NW Lab., Richland, Wash., USA (1974).
- (6) HOLM, E. PERSSON, R.B.R. Fallout plutonium in Swedish reindeer lichens. Health Phys. 29 (1975) 43.
- (7) HOLM, E., FUKAI, R. Determination of americium and curium by using ion-exchange in nitric-acid/methanol medium for environmental analysis. Talanta 23 (1976) 853.
- (8) NETHERINGTON, J.A., et al. "Environmental and public health consequences of the controlled disposal of transuranic elements to the marine environment", p. 139, Transuranium Nuclides in the Environment, IAEA, Vienna (1976).
- (9) LIVINGSTON, H.D. et al. Pu-241 in the marine environment by a radiochemical procedure, Earth and Plan. Sci. Lett. 25 (1975) 361.
- (10) NOSHKIN, V.E., et al. "Transuranics and other radionuclides in Bikini Lagoon: Concentration data retrieved from aged coral sections". UCRL-75785, Lawrence Livermore Lab., Calif. USA (1975).

By analyzing profiles of lichen carpet and soil layers the accumulated area content of Am-241 was determined to be  $210 \pm 20$  pCi/m<sup>2</sup> in 1972; the corresponding value for Pu-241 was  $7800 \pm 900$  pCi/m<sup>2</sup>.

The results of present investigations indicate that Am-241 was present in the environment from nuclear weapons tests prior to 1960, though the U.S. and U.S.S.R. tests series in 1961-1962 comprise the major input. In 1975 about 15-20% of the Am-241 in the lichen carpet originated from direct fallout and 80-85% are derived by in situ build up from Pu-241.

Activity ratios of <sup>241</sup>Pu and <sup>241</sup>Am

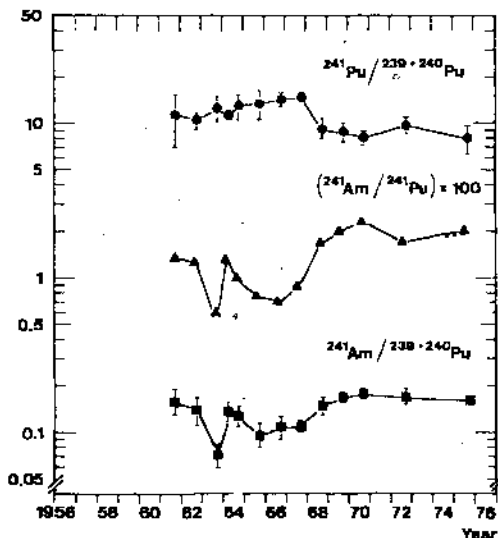

Fig. 2 The temporal variation of the activity-ratios Pu-241/Pu-239+240, Am-241/Pu-241 and Am-241/Pu-239+240 in lichen carpets.

Results of the analysis of the Windscale sediments give an activity ratio for Pu-241/Pu-239+240 of  $22 \pm 2$ , in good agreement with the activity ratio in the effluent which is reported to be about 10-100 (8). The corresponding ratio for the IAEA intercalibration samples AG-I-1 (seaweed) and SW-I-2 (seawater) which are collected in the same area as the sediment sample is about 30 (9). For the Bikini sediment samples a lower value of the Pu-241/Pu-239+240 activity ratio was found. In 1976 this was  $8.2 \pm 0.5$ , and, corrected for physical decay to 1954 it became 25. This is slightly less than the value 3 which has been observed in coral sections from the same place (10).

ENVIRONMENTAL MONITORING FOR SOME  
TRANSURANIUM ELEMENTS

J. Sedlet and N. W. Golchert  
Occupational Health and Safety Division  
Argonne National Laboratory Argonne, IL 60439, U.S.A.

## 1. INTRODUCTION

Knowledge of contemporary environmental levels of transuranium elements is necessary as baseline information if the future impact of nuclear fuel plants and power reactors is to be evaluated. The chemical behavior of these elements at low concentrations in the environment is also important in hazard prediction. This paper describes methods used by our group for the analysis of environmental materials for several transuranium elements and summarizes the results for the past several years. In some cases comparison with natural uranium and thorium was useful, and their concentrations were also determined. The detailed data are given in a series of annual reports (1).

## 2. RADIOCHEMICAL PROCEDURES

Measurements were made by alpha-particle spectrometry, except for some uranium fluorometric analyses, with the use of radiotracers to determine the chemical recovery by isotope dilution. Where possible, isotopic alpha emitters were used as tracers. Exceptions were:  $^{234}\text{Th}$  for thorium isotopes;  $^{239}\text{Np}$  or  $^{238}\text{Pu}$  for  $^{237}\text{Np}$ ; and  $^{243}\text{Am}$  for Cf and Cm isotopes.  $^{243}\text{Am}$  was used for Am, Cf, and Cm since these actinides were separated together under conditions where they behave quantitatively the same. Although  $^{239}\text{Np}$  was initially used as a tracer for  $^{237}\text{Np}$ , it was found that Np could be separated with Pu so that both elements could be determined by alpha spectrometry with  $^{238}\text{Pu}$  tracer without separating them from each other.

Water was analyzed by coprecipitating the transuranium elements and Th with  $\text{CaF}_2$  after reduction with sodium bisulfite. The  $\text{CaF}_2$  was dissolved in 8N  $\text{HNO}_3$ -saturated  $\text{Al}(\text{NO}_3)_3$  solution, and the solution passed through a Dowex-1 ion exchange column to adsorb Th, Pu, and Np. The Th was eluted with concentrated HCl, and the Pu and Np either eluted together with dilute HCl-HF solution, or the Pu eluted by reduction with  $\text{NH}_4\text{I}$  solution and then the Np with dilute HCl-HF. The initial column effluent and washings were evaporated nearly to dryness, the acidity adjusted to pH 2 with  $\text{NH}_4\text{OH}$ , and the trivalent actinides extracted into a solution of Aliquat 336 in xylene and re-extracted into dilute acid.

Soil, air particulates, vegetation, and bottom sediment were leached by treatment with hot mineral acids, including HF. The insoluble material was filtered, ashed, and the acid treatment repeated. The solution was made 8M in  $\text{HNO}_3$  and the separation described above performed with one change. Prior to the extraction step, the evaporated  $\text{Al}(\text{NO}_3)_3$  solution was made 10N in  $\text{NH}_4\text{NO}_3$  and the U extracted into ethyl acetate. The trivalent actinides were then extracted with Aliquat 336.

The separated elements were electrodeposited onto Ag or Pt disks from  $\text{NH}_4\text{Cl-HCl-H}_2\text{C}_2\text{O}_4$  solution ( $\text{pH} \sim 2$ ) and counted with an alpha spectrometer that used a surface barrier silicon diode detector. Beta counting was used to measure the yield when  $^{239}\text{Np}$  and  $^{234}\text{Th}$  were used as tracers.

### 3. RESULTS

Concentrations of several nuclides in air from the same location (near ANL) are shown in Table 1. The values are averages of monthly samples; the uncertainties are the standard errors of the mean, and are a measure of the range in the monthly concentrations.

Year	$^{239,240}\text{Pu}$	$^{238}\text{Pu}$	$^{232}\text{Th}$	U (nat)
1972	$27 \pm 5$	$2.2 \pm 0.4$	-	-
1973	$13 \pm 3$	$0.7 \pm 0.3$	$15 \pm 2$	$88 \pm 10$
1974	$32 \pm 7$	$0.7 \pm 0.1$	$14 \pm 2$	$74 \pm 7$
1975	$18 \pm 4$	$0.5 \pm 0.2$	$15 \pm 1$	$77 \pm 6$
1976	$6.1 \pm 0.8$	$0.6 \pm 0.2$	$16 \pm 1$	$65 \pm 5$

Table 1 Average Pu, Th, and U Concentrations in Air ( $\text{aCi/m}^3$ )

The concentrations of all nuclides varied appreciably from month to month. Variations in the  $^{239,240}\text{Pu}$  concentrations reflected changes in fallout from nuclear tests; each year a maximum was observed in the spring and a minimum in the fall. Concentrations of Th and U also showed large monthly variations, about a factor of 10, but in a less orderly fashion. Their average annual concentrations have been quite constant, as would be expected for naturally-occurring materials. The solids content of air varied by about a factor of four, with a minimum in December or January and a maximum in July.

The amount of Pu in air from resuspension of surface material is of interest in assessing the long-term inhalation hazard. To obtain the resuspension factor [ $\text{conc/m}^3(\text{air})/\text{conc/m}^2(\text{surface})$ ] from the data, the air concentration must be corrected for the fallout contribution. If this contribution is not known, it is reasonable that factors calculated for Th and U would more accurately represent Pu resuspension than values calculated from Pu concentrations alone. In Table 2, the "corrected" factor for Pu is calculated with the assumption that the resuspended Pu in the airborne solids has the same concentration as the top 5 cm of soil. On this basis, about 2% of the airborne Pu was due to resuspended soil. The factors obtained for Th, U, and "corrected" Pu are in reasonable agreement with each other, and with reported factors of  $10^{-9}$  to  $10^{-10}$  for aged depositions (2).

Nuclide	Air Concentration ( $\text{aCi/m}^3$ )	Soil Concentration ( $\text{nCi/m}^2$ )	Factor ( $\text{m}^{-1}$ )
$^{232}\text{Th}$	14	180	$0.8 \times 10^{-10}$
Uranium (nat)	74	780	$1.0 \times 10^{-10}$
$^{239,240}\text{Pu}$ (corrected)	0.70	1.2	$5.8 \times 10^{-10}$
$^{239,240}\text{Pu}$ (total)	32	1.2	$2.7 \times 10^{-8}$

Table 2 Resuspension Factors for Th, U, Pu (1974)



Plutonium in soil and grass is shown in Table 3. The results, averages of 8 to 30 samples each year, are similar to those obtained by others at similar northern latitudes. In terms of deposition, grass contained about  $10^4$  less Pu than soil from the same locations. The sampling and sample treatment methods do not permit the calculation of meaningful uptake factors since the soil was sampled down to 30 cm (50-90% of the Pu was in the first 5 cm), the grass was washed with water and oven-dried before analysis, and perhaps not all the surface Pu was removed.

Year	Soil ( $\mu\text{Ci}/\text{m}^2$ )		Grass ( $\text{pCi}/\text{m}^2$ )	
	$^{239,240}\text{Pu}$	$^{238}\text{Pu}$	$^{239,240}\text{Pu}$	$^{238}\text{Pu}$
1972	$1.8 \pm 0.2$	$0.27 \pm 0.03$	$0.32 \pm 0.15$	-
1973	$2.5 \pm 0.3$	$0.20 \pm 0.03$	$0.13 \pm 0.04$	-
1974	$1.9 \pm 0.4$	$0.13 \pm 0.04$	$0.25 \pm 0.08$	$0.02 \pm 0.03$
1975	$2.2 \pm 0.3$	$0.17 \pm 0.05$	$0.13 \pm 0.05$	$< 0.01$

Table 3 Plutonium Content of Soil and Grass

The surface deposition of Pu for the past several years averaged about  $7 \text{ pCi}/\text{m}^2/\text{month}$ , but shows pronounced spring peaks which correlate with atmospheric nuclear detonations. The annual depositions ranged between 4 and  $25 \text{ pCi}/\text{m}^2$  from 1973 to 1976. The total deposition for these four years was only about 2.5% of the total soil inventory.

Table 4 gives average concentrations of several transuranics in surface water during 1975 near Argonne National Laboratory. Waste water, after treatment and analysis, is discharged into Sawmill Creek, which flows into the Des Plaines River, which in turn empties into the Illinois River. Very small but measurable amounts were found in Sawmill Creek, but these concentrations were not detectable as to origin in the larger streams. The Pu concentrations in the Des Plaines and Illinois Rivers ( $0.5 \pm 0.3 \text{ fCi/l}$ ) are the same as found in other bodies of water in the area, including Lake Michigan, and may represent the solubility of fallout Pu in natural water systems.

Nuclide	Sawmill Creek	Des Plaines River	Illinois River
$^{237}\text{Np}$	$42 \pm 12$	$< 0.5$	$< 0.5$
$^{238}\text{Pu}$	$< 2.6$ (*)	$< 0.5$	$< 0.5$
$^{239,240}\text{Pu}$	$9.4 \pm 1.3$	$0.7 \pm 0.2$	$0.3 \pm 0.1$
$^{241}\text{Am}$	$4.3 \pm 0.7$	$< 0.5$	-
$^{242}\text{Cm}/^{252}\text{Cf}$	$< 1.2$ (*)	$< 0.5$	-
$^{244}\text{Cm}/^{249}\text{Cf}$	$4.5 \pm 0.8$	$< 0.5$	-

\* Average of many samples, some containing less than the detection limit.

Table 4 Transuranium Nuclides in Surface Water (fCi/l), 1975

Environmental concentrations of a few transuranics are adequate to study some of their properties. For example, information on the solubility of Np and Pu in Sawmill Creek water is given in Table 5. These samples were acidified to  $0.1\text{N HNO}_3$  and filtered through cellulose paper immediately after collection. The results show that much of the Pu can be readily filtered,

and therefore much of the Pu actually released into waste water may be removed in treatment. The results are consistent with the known solubilities of the most stable oxidation states of these two elements. The total Pu release cannot be judged on the basis of water concentration alone, and Np, at the same release level, may be more important dosimetrically than Pu because of its greater solubility in aquatic systems.

Location *	<sup>237</sup> Np		<sup>239,240</sup> Pu	
	Water	Residue	Water	Residue
Below	6.7 ± 1.1	1.2 ± 0.4	5.8 ± 1.1	10.9 ± 1.2
Below	3.3 ± 0.8	< 1	2.0 ± 0.7	2.4 ± 0.5
Below	185 ± 9	1.6 ± 0.6	5.5 ± 1.0	21.5 ± 2.2
Below	149 ± 7	< 1	2.9 ± 0.7	3.0 ± 0.7
Below	183 ± 8	3.8 ± 0.9	9.4 ± 1.3	19.3 ± 2.1
Above	< 1	< 1	< 0.5	0.6 ± 0.5
Percent (avg)	> 90	< 10	36	64

\* Above and below the waste water outfall.

Table 5 Distribution of Np and Pu between Water and Residue (fCi/l)

The distribution of Pu and U between bottom sediment and the overlying water are compared in Table 6. The U concentrations are in their natural ranges. Pu is evidently easier to detect in the sediment than in water. Since sediment can accumulate Pu over a period of time, it is a very sensitive indicator of aquatic contamination, and can be useful in covering time periods during which no water samples were collected.

Location	U (nat)		<sup>239,240</sup> Pu		<sup>238</sup> Pu	
	Water	Sediment	Water	Sediment	Water	Sediment
Sawmill Creek	1700	1400	9	19	< 2	0.7
Des Plaines River	1400	1500	0.7	25	< 2	1.3
Illinois River	1100	3500	0.2	1.0	< 2	< 0.1

Table 6 U and Pu in Water (fCi/l) and Bottom Sediment (fCi/g)

Plankton in this case is not a useful indicator of Pu contamination, as shown by the data in Table 7. No difference between locations was detected, and the Pu is attributed to fallout only.

Location	U (nat)		<sup>239,240</sup> Pu		<sup>238</sup> Pu	
	Water	Sediment	Water	Sediment	Water	Sediment
Above Outfall	390 ± 40		24 ± 1		< 0.1	
Below Outfall	310 ± 30		13 ± 1		0.8 ± 0.7	
Below Outfall	620 ± 40		16 ± 1		0.2 ± 0.2	

Table 7 U and Pu in Sawmill Creek Plankton (aCi/g)

#### REFERENCES

- (1) GOLCHERT, N. W., DUFFY, T. L., and SEDLET, J., Environmental Monitoring at Argonne National Laboratory, U.S.E.R.D.A. Reports ANL-76-29 (1975), ANL-75-18 (1974), ANL-8078 (1973), ANL-8007 (1972).
- (2) BENNETT, B. G., Plutonium and the Transuranium Elements, U.S.A.E.C. Report WASH-1359 (1974), pp. 132-133.

## FALL-OUT PLUTONIUM IN AUSTRIAN SOIL SAMPLES

K. Zwiwek, F. Steger  
Austrian Atomic Energy Research Organization Ltd.  
Research Center Saibersdorf, Austria

## 1. INTRODUCTION

The total amount of  $^{239}\text{Pu}$  produced in nuclear tests until 1974 was estimated to about 320 KCi (1). This activity has been released into the atmosphere and distributed with global fall-out accompanied by small amounts of  $^{238}\text{Pu}$  in the ratio of 0,02 to 0,04 (2). Additionally a quantity of  $^{238}\text{Pu}$  was injected into the stratosphere from a satellite (SNAP 9A) which burnt up reentering the atmosphere using this radionuclide as a power source. Extensive investigations about  $^{239},^{238}\text{Pu}$  concentrations in surface air showed that the main part of  $^{239}\text{Pu}$  activity is found on the southern hemisphere (3). For geographic latitudes at  $45^{\circ}\text{N}$  a fall-out deposition of  $\approx 2 \text{ mCi } ^{239}\text{Pu}/\text{km}^2$  was reported (4). Profile studies (4 - 6) demonstrated that under environmental conditions at least 80 % of Pu remained insoluble and was fixed in a layer down to a depth of 10 cm.

The aim of our work was to perform a survey on fall-out concentrations in Austrian soil samples under specific conditions of a mountain region with areas strongly differing in altitude and in the amount of mean annual rainfall.

Furthermore the analytical procedure used for radiochemical determination of plutonium should be tested on various soil samples.

## 2. EXPERIMENTAL TECHNIQUES

The soil samples were collected from an area of  $10 \times 10 \text{ cm}$  to a depth of 5 to 10 cm. Air dried aliquotes of 50 g were sieved to remove large stones and were spiked with a small quantity of  $^{235}\text{Pu}$  to check the Pu recovery for each analysis. The samples were heated in a muffle furnace at  $450^{\circ}\text{C}$  to destroy organic materials and then leached with 200 ml half concentrated nitric acid boiling for 3 hours.  $\text{NaNO}_2$  was added to get Pu in tetravalent state (7). After cooling the suspension was centrifuged and the separated liquor extracted with 25% tridodecylamine in xylene. The organic phase was washed with 10 N hydrochloric acid to remove thorium completely. Plutonium was stripped together with uranium from the amine phase with a dilute hydrochloric/hydrofluoric acid mixture. After repeated evaporations to dryness a nearly white residue was obtained. Plutonium was taken up in slightly acidic ammonium chloride solution for electrodeposition on stainless steel disks (8). Alpha spectrometric measurements were carried out with a silicon surface barrier detector, with a counting time of 40,000 sec the detection limit for the counter (i.e. 4 times statistical error of the background measurements) was about 15 fCi (9). Measurements of chemical blanks, however, showed that in practice a detection limit of only about

50 fCi/sample could be reached. Therefore with 50 g samples and a mean recovery for Pu of  $32,6 \pm 15,9 \%$  (arithmetic mean from 20 analysis with added  $^{235}\text{Pu}$ )  $^{239}\text{Pu}$  concentrations of 3 fCi/g soil could be determined.

### 3. RESULTS

Typical Pu concentrations in Austrian soil samples were presented in table 1:

TABLE 1  
 $^{239}\text{Pu}$  concentrations in Austrian soil samples

sample no.	Location	height above sea level (m)	annual rainfall (mm)	fCi $^{239}\text{Pu}$ /g
19	Seibersdorf	200	600 - 700	$14 \pm 2^*$
31	Reisenberg	200	600 - 700	$15 \pm 2$
22	Wolkersdorf	200	600 - 700	$8 \pm 2$
21	Zwettl	300	600 - 700	$8 \pm 1$
11	Dürfl	250	700 - 800	$14 \pm 2$
6	Kremsmünster	400	800 - 900	$8 \pm 1$
9	Asperg	400	800 - 900	$7 \pm 1$
4	Pöngg	800	900 - 900	$8 \pm 1$
5	Bad Aussee	700	1000 - 1250	$26 \pm 5$
7	Fertisau	1200	1250 - 1500	$13 \pm 7$
17	Ennsalpe	1000	1250 - 1500	$58 \pm 4$
2	Almsau	750	1500 - 2000	$20 \pm 3$
1	Ödsee	750	2000 - 2500	$100 \pm 12$
3	Hinterstoder	750	2000 - 2500	$70 \pm 8$
8	Gariassstein	1700	1250 - 1500	$48 \pm 5$
13	Schwarzenau	1500	1500 - 2000	$163 \pm 22$
16	Gsiesertal	1700	1500 - 2000	$107 \pm 7$
14	Stallersattel	2200	1500 - 2000	$142 \pm 13$
15	Haidacher Alm	1900	2000 - 2500	$161 \pm 10$

\*): statistical error of accounting for  $^{239}\text{Pu}$  and  $^{238}\text{Pu}$

These values differ from 3 to 163 fCi  $^{239}\text{Pu}$ /g soil, depending on the location from where the samples were taken. These results correlated with the total amount of annual rainfall and with height above the sea level can be distinguished in three categories. The estimated  $^{239}\text{Pu}$  deposition was found to be:

region I: (altitude  $< 1000$  m, annual rainfall 600 - 900 mm)  
plane areas in eastern part of Austria with low rainfall:  
 $1,2 \pm 0,2$  nCi/k<sup>2</sup>

region II: (altitude  $< 1200$  m, annual rainfall 1250 - 1500 mm)  
mountain region with high rainfall:  
 $5,1 \pm 1,5$  nCi/k<sup>2</sup>

region III: (altitude 1500 - 2500 m, annual rainfall 1250 - 2500 mm)  
alpine regions with extremely high rainfall:  
 $15,3 \pm 2,9$  mCi/km<sup>2</sup>

The recorded  $\alpha$ -spectrum of some samples with high <sup>239</sup>Pu concentrations additionally showed <sup>238</sup>Pu in the ratio of  $0,03 \pm 0,01$  which is typical for fall-out deposition. As a typical example the  $\alpha$ -spectrum of soil sample no.14 is presented in Figure 1.

#### REFERENCES

- (1) HARDY, E.P., P.W. KREY, H.L. VOJCHÖK, Nature 241, 444 (1973)
- (2) "Ionizing Radiation Levels and Effects", Rep. of United Nations Scientific Committee on the Effects of Atomic Radiation, Vol. I, p.54, New York (1972)
- (3) VOJCHÖK, H.L., Health and Safety Laboratory, Rep. HASL-227 (1970)
- (4) DESORTOLI M.C., P. GASLIONE, Health Phys. 17, 701 (1969)
- (5) KREY P.W., E.P. HARDY, Health and Safety Laboratory, Rep. HASL-235 (1970)
- (6) McLENDON H.R., Health Phys. 28, 347 (1975)
- (7) VESELSKY J.C., Int. J. Appl. Rad. Isot. 27, 499 (1976)
- (8) IRLWICK K., H. SORANTIN, Österr. Studienges. f. Atomenergie, Rep. SGAE-2388 (1974)
- (9) STEGER F., E. ERBANICH, E. LOVRANICH, A. HEFNER, Österr. Studienges. f. Atomenergie, Rep. SGAE-2397 (1974)

#### ACKNOWLEDGEMENT

The authors are indebted to the Austrian Federal Ministry of Health and Environmental Protection for financial support of this work.

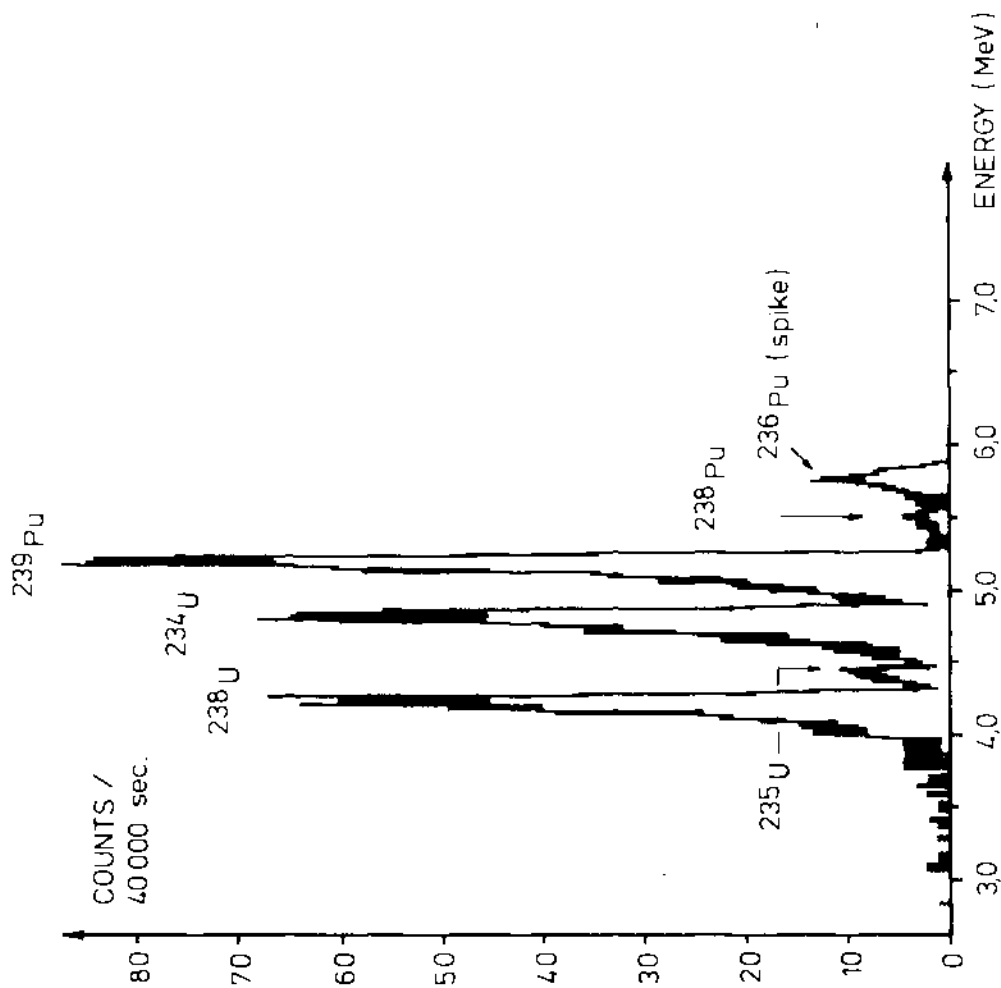

## PLUTONIUM IN BALTIC SEDIMENTS

Kristiina Simola, T. Jaakkola and J. K. Miettinen  
 Department of Radiochemistry, University of Helsinki, Finland  
 A. Voipio and L. Niemistö  
 Institute of Marine Research, Helsinki, Finland

Marine sediments accumulate the bulk of plutonium produced by nuclear tests. The nuclear power industry will form an additional source of plutonium. It is important to determine the present "background" levels of plutonium in sediments and to compare the accumulation rate in the Baltic with that in other areas of the world.

In the Baltic Sea the younger Post-Glacial sediments covering the glacial deposits are unevenly distributed (1). This makes it difficult to obtain samples representing the whole of the Baltic Sea, and our results based on only a few cores have to be considered preliminary.

Plutonium was determined on four sediment cores collected from the Baltic Sea in 1974 and 1975 by the Institute of Marine Research, Helsinki, the Institute of Radiation Protection, Helsinki and Tvärminne Zoological Station, University of Helsinki. The sampling sites are indicated in Fig. 1. Two of the samples were from oxygenated coastal sediment with benthic life (I, Tvärminne, 26 m deep and II, Håstholmsfjärden, 11 m deep). The two other cores

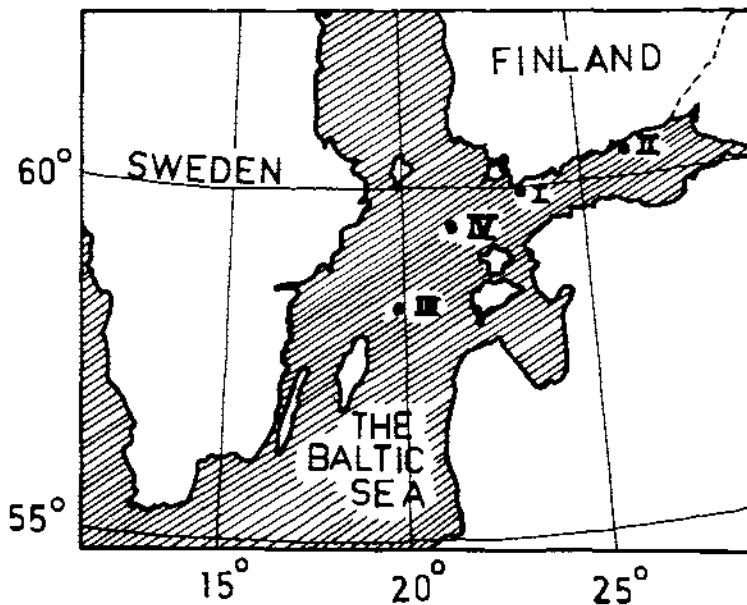

Fig. 1. Locations of sediment samples analysed for plutonium:

- I Gulf of Finland, Zoological Station, University of Helsinki (59°50'N; 23°15'E)
- II Gulf of Finland, Håstholmsfjärden (60°22'N; 26°22'E)
- III Baltic Sea, Fårö (58°00'N; 19°54'E)
- IV Baltic Sea, Teili (59°25'N; 21°39'E)

were collected from deep basins in the Baltic (III, Fårö, 183 m deep and IV, Teili, 164 m deep) where the bottoms were anoxic, with no benthic life, and where the rate of sedimentation is rather high. The samples were taken with a gravity corer which consists of a plexiglass tube surrounded by a stainless steel body and the sediment cores were split into transverse sections of 0.8, 1.8 or 2.8 cm thick with a special sectioning apparatus (2).

Plutonium was separated from samples using anion exchange technique and electrodeposited onto platinum disc for determination of  $\alpha$ -activity (3,4). The accuracy of method was tested by making 12 parallel determinations on a homogenized surface sediment sample. The mean value was  $186 \pm 14$  pCi/kg dry wt ( $-1\sigma$ ).

The Pu-239,240 content of the sediment cores is presented in Fig. 2 as pCi/kg dry wt in the different core sections. The highest plutonium concentrations are found near the surface, at depths of 0-8 cm. In all cores the plutonium concentration decreases sharply at a depth of about 6-8 cm, but differences are evident between the profiles.

In profiles I and II (Ivärminne and Hästholmsfjärden) a rather broad maximum can be seen. The concentrations are about 170 pCi/kg dry wt down to the depth of 6-8 cm. In 1970 the concentration of Pb-210 : Po-210 was determined on a sediment core from Ivärminne area (Storfjärden). The concentrations were found to be fairly uniform in the uppermost 5 cm of the sediment. This was attributed to bioturbation and to the effect of wave action on the sediment surface during strong winds. In core IV (Teili) a rather sharp maximum can be seen between 2 and 6 cm (370 pCi/kg dry wt). The rate of sedimentation has recently been determined on a Teili core by the Pb-210/Po-210 technique (6). On the basis of these datings, the 1963 sediment layer was found at the depth of 44 mm from the 1974 sediment surface. This is in good agreement with our present results, which indicate that the maximum plutonium concentration was at that depth.

Both Fårö and Teili (samples III and IV) are separate basins, where the sedimentation is also dependent on horizontal transport of material from areas with non-deposition or erosion. Ivärminne and Hästholmsfjärden represent areas where the sediments show considerable terrestrial influence.

Table 1 shows activities per unit area. The integrated values in the four cores ranged from  $1.2-3.3$  mCi/km<sup>2</sup>. These values can be regarded as the cumulative fallout of plutonium.

Maximal deposition rate of plutonium from fallout was measured in 1963. In New York it was  $0.6$  mCi Pu-239/km<sup>2</sup> (7). The cumulative deposit of Pu-239,240 in New York city in 1973 was  $2.6$  mCi/km<sup>2</sup> (7). The values recorded from soil collected 1970-71 was in northern latitudes at  $40-50^{\circ}$ N  $2.2-0.5$ ,  $50-60^{\circ}$ N  $1.3-0.2$  and  $60-70^{\circ}$ N  $1.6-1.0$  mCi/km<sup>2</sup> (8).

The value measured by Noshkin in the sediments of Buzzard's Bay ( $41^{\circ}$ N,  $70^{\circ}$ W) was  $2.3$  mCi/km<sup>2</sup> (9) and the values Koide et al. from the sediments of Santa Barbara and Soledad basins to which crustal materials are carried by wind were  $4.5$  and  $5.0$  mCi/km<sup>2</sup>, resp. (10). On the whole, our results (Table 1) are in good agreement with the cumulative deposit in New York city and Noshkin's value from Buzzard's Bay sediment.

When the possible hazards to human health are considered, attention should be paid to pathways by which plutonium can pass. First, sediment dredged from the bottom can be inhaled as windborne dust. Second, the gastrointestinal pathway may become significant if man consumes bottom animals



as his staple food. However, this seems unlikely in the Baltic Sea area. Anyhow, plutonium food-chains seem to lead to reduction of the concentration, when passing from lower to higher trophic levels (12).

ACKNOWLEDGEMENT

This investigation was partially supported by Contract OB E(11-1)-3011 from the US Energy Research and Development Administration.

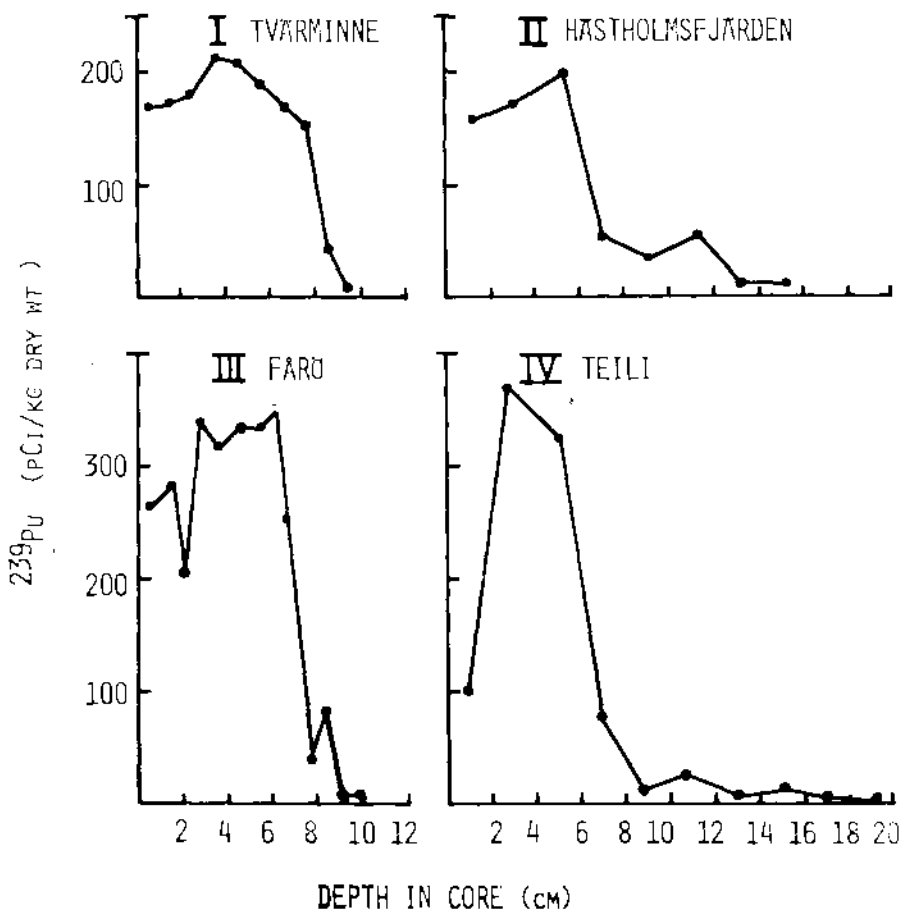

Fig. 2. Vertical distribution of the  $^{239,240}\text{Pu}$  concentrations found in four marine sediment core samples from the Baltic Sea.

Table 1. Amounts of  $^{239,240}\text{Pu}$  per unit area in different sections of cores from bottom sediments and the integrated mean sediment loads.  
 $1 \text{ mCi/km}^2 = 100 \text{ fCi/cm}^2$ .

Sample depth in core (cm)	$^{239,240}\text{Pu}$ concentrations (fCi/cm <sup>2</sup> )			
	I Hävärminne	II Loviisa	III Pärö	IV Teili
0-2	44 <sup>+2</sup>	47 <sup>+3</sup>	18 <sup>+1</sup>	11 <sup>+1</sup>
2-4	94 <sup>+4</sup>	59 <sup>+3</sup>	23 <sup>+2</sup>	67 <sup>+4</sup>
4-6	92 <sup>+4</sup>	72 <sup>+5</sup>	35 <sup>+2</sup>	68 <sup>+5</sup>
6-8	86 <sup>+4</sup>	29 <sup>+2</sup>	29 <sup>+3</sup>	35 <sup>+3</sup>
8-10	15 <sup>+1</sup>	18 <sup>+2</sup>	10 <sup>+1</sup>	7 <sup>+1</sup>
10-12		25 <sup>+2</sup>		15 <sup>+2</sup>
12-14		7 <sup>+0.3</sup>		1 <sup>+0.5</sup>
14-16		5 <sup>+1</sup>		11 <sup>+3</sup>
16-18				0
18-20				1 <sup>+0.4</sup>
The integrated values	3.3 mCi/km <sup>2</sup>	2.5 mCi/km <sup>2</sup>	1.2 mCi/km <sup>2</sup>	2.4 mCi/km <sup>2</sup>

#### REFERENCES

- (1) IGNATIUS, K. and NIEMISTÖ, L., Sediments and sedimentation in the Baltic. (In Finnish with English summary) Luonnon Tutkija 1971: 72-80
- (2) NIEMISTÖ, L., A Gravity corer for studies of soft sediments, Merentutkimuslaitoksen julkaisu No 238 (1974)
- (3) Procedures Manual, US AEC, Health and Safety Laboratory, HASL-300 (1972) E-PU-06-10
- (4) HAKANEN, M. and JAAKKOLA, T., Determination of plutonium in biological samples. Unpublished results.
- (5) KAURANEN, P. and MIETTINEN, J.K.,  $^{210}\text{Pb}$  and  $^{210}\text{Po}$  in some aqueous ecosystems and food chains. Dept of Radiochemistry, Univ of Helsinki, At (1-30)-3446. Ann.Rep. (1971)
- (6) HÄSÄNEN, E., NIEMISTÖ, L. and VOIPIO, A., Unpublished results.
- (7) HARDY, E.P., Plutonium and other transuranium elements, sources, environmental distribution and biomedical effects, WASH-1359, US AEC, Dec. 1974
- (8) HARDY, E.P., KREY, P.W. and VOLCHOK, H.L., Nature 241 (1973) pp. 444-5
- (9) NOSHKIN, V.E., Health Physics 22 (1972) p. 537
- (10) KOIDE, M., GRIFFIN, J.J. and GOLDBERG, E.D., Journal of Geophysical Research 80, No 30 (1975) pp. 4153-62
- (11) MIETTINEN, J.K., JAAKKOLA, T. and JÄRVINEN, MARJA, Plutonium isotopes in aquatic foodchains in the Baltic Sea, Proceedings of International Symposium on Radiological Impacts of Releases from Nuclear Facilities into Aquatic Environments, IAEA, Otaniemi, Finland, 30 June - 4 July 1975

## PLUTONIUM AND AMERICIUM IN THE FOODCHAIN LICHEN-REINDEER-MAN

T. Jaaakola, M. Hakanen, Marja Keinonen, Helena Mussalo and J.K. Miettinen  
Department of Radiochemistry, University of Helsinki, Finland

The atmospheric nuclear tests have produced a worldwide fallout of trans-uranium elements. In addition to plutonium measurable concentrations of americium are to be found in terrestrial and aquatic environments. Results of the investigations on transfer of plutonium along the foodchain lichen-reindeer-man have been published earlier (1,2).

In the present study the metabolism of plutonium in reindeer was investigated by analyzing plutonium in liver, bone and lung collected during 1963-1976. To determine the distribution of plutonium in reindeer all tissues of four animals of different ages were analyzed. To estimate the uptake of plutonium from the gastrointestinal tract in reindeer, the tissue samples of elk were also analyzed. Elk which is of the same genus as reindeer does not feed on lichen but mainly on deciduous plants, buds, young twigs and leaves of trees and bushes. The composition of its feed corresponds fairly well to that of reindeer during the summer time.

Studies on behaviour of americium along the foodchain lichen-reindeer-man were started by determining the Am-241 concentrations in lichen and reindeer liver. The Am-241 results were compared with those of Pu-239,240.

The plutonium contents of the southern Finns whose diet does not contain reindeer tissues were determined by analyzing autopsy tissue samples (liver, lung and bone). The southern Finns form a control group to the Lapps consuming plenty of reindeer tissues. Plutonium analyses of the placenta, blood and tooth samples of the Lapps are performed presently.

For separation of plutonium and americium the samples were dried and wet-ashed by  $\text{HNO}_3\text{-HCl}$ . Pu-242 and Am-243 were used as tracers for yield determination. Plutonium was isolated by anion-exchange and electrodeposited on a platinum disc from a dilute  $\text{HNO}_3$ -solution. For separation of americium the anion- and cation-exchange techniques combined with HDEHP extraction or  $\text{BiFO}_4$ -coprecipitation were used (3). Americium was electrodeposited from a  $\text{NH}_4\text{C}_2\text{O}_4$ -oxalic acid solution. Alpha spectra of Pu and Am were determined using a surface barrier semiconductor-detector and a 256-channel pulse-height analyzer.

Maximal concentrations of Pu-239,240 and Am-241 in lichen (sp. *Cladonia*) 220-240 and 40 pCi/kg dry wt. resp., were found in 1964 (Fig. 1). Comparison to Pu-239,240 concentrations in surface air, determined in the United Kingdom by Cambray et al. (4), indicates a short residence time for these radio-nuclides in lichen. The maximal concentration of plutonium in air as well as in grass and birch leaves (100 pCi/kg dry wt.) occurred in 1963 (Fig. 1).

Am-241 is a daughter nuclide of Pu-241 which decays with a half-life of 14.9 a to Am-242. In fresh fallout the Pu-241/Pu-239,240 activity ratio was about 15 in 1963 (5). According to this study this ratio in lichen was 12.0-2.3 in 1963, 10.9-1.8 in 1965 and 7.7-3.7 in 1974. In 1963 the Pu-241 concentration in lichen was 2400 pCi/kg dry wt. The activity ratio Am-241/Pu-239,240 in lichen increases by time. It was about 0.15 in 1965 and 0.25 in 1973. This increase is probably mainly due to the Am-241 produced by decay of Pu-241 in the lichen and does not indicate a higher retention of americium by lichen compared with that of plutonium. It has been estimated that the activity ratio Am-241/Pu-239,240 of integrated fallout on the earth's surface will be at its maximum, 0.42, about the year 2040 (6).

The highest Pu-239,240 concentration measured in reindeer was 56 pCi/kg fresh wt. It was found in the liver of a 12-13 year old reindeer slaughtered in 1973 (Table 1). In general, the plutonium content of liver is higher in old animals which have lived during the period of high plutonium content in lichen. In some cases, however, the high concentrations are likely due to exceptionally high contribution of lichen to the diet of reindeer (Table 1). The major part of plutonium in reindeer occurs in liver. Skeleton contains usually 20-30% of the body burden. Only 1-10% occurs in lung (Fig. 2).

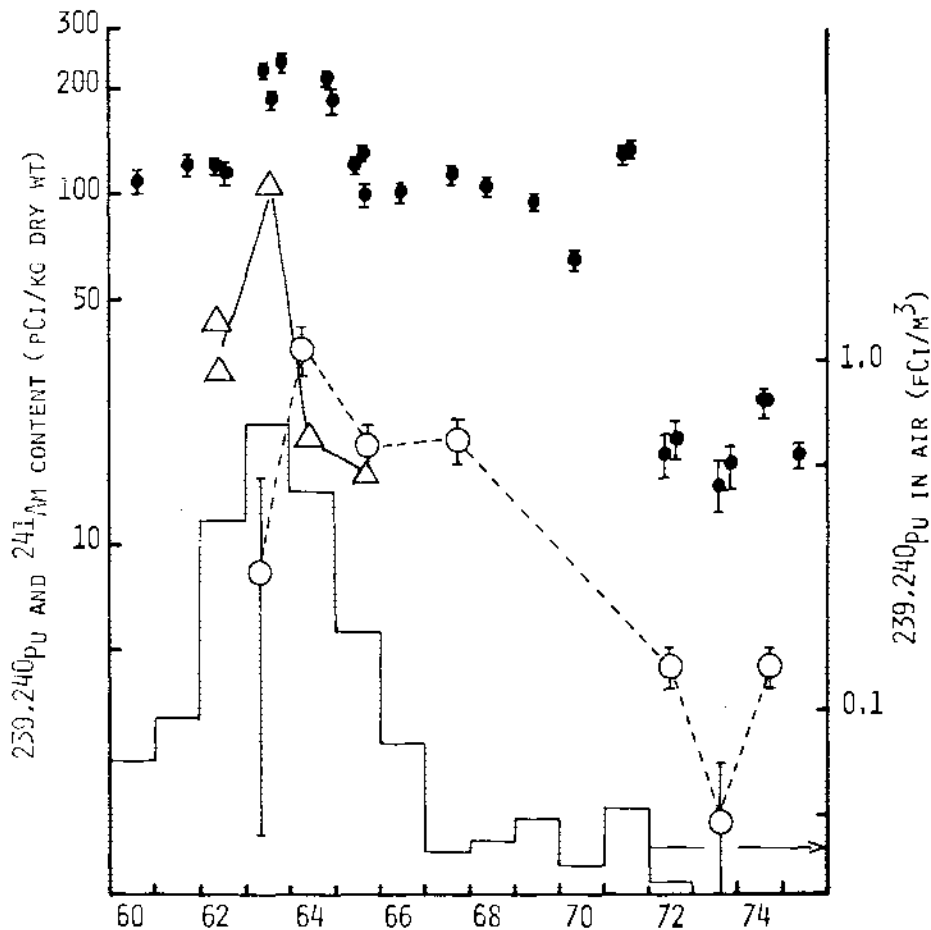

FIGURE 1  $^{239,240}\text{Pu}$  (●) and  $^{241}\text{Am}$  (○) in lichen and  $^{239,240}\text{Pu}$  in birch leaves and grass (△) in Finnish Lapland during 1960-1975. Standard deviation of radioassay (one  $\sigma$ ) is indicated. In addition the  $^{239,240}\text{Pu}$  concentrations in air measured at Chilton, United Kingdom are indicated (Cambray et al. Ref. 4)

Sampling year	No of animals	Age years	pCi/kg fresh wt	
			mean	(min-max)
1963-64	5	3.5-5	11.4	(3.5-31.3)
1965-66	5	1.5-4	7.7	(1.6-18.6)
1967-68	33	2-8	11.6	
1971-72	6	2-4	3.9	(2.4-5.5)
1973	3	3-6	2.1	(1.6-2.4)
1973	1	12-15	55.6	
1974	6	3-13	3.1	(0.6-7.1)
1975	10	3-8	2.8	(0.4-8.2)
1976	6	1.5-3	1.2	(0.7-2.4)
1976	2	1-6	29.9	(23.3-31.4)

Table 1. Pu-239,240 in reindeer liver in Finnish Lapland during 1963-1976. Standard deviation of the radioassay (one  $\sigma$ ) is indicated.

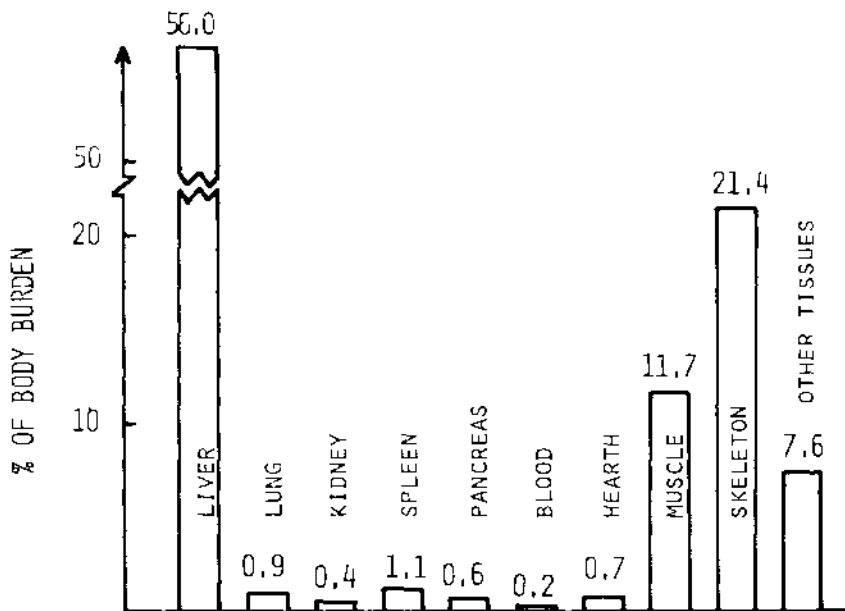

FIGURE 2 DISTRIBUTION OF  $^{239,240}\text{Pu}$  IN REINDEER; AGE 13.5 YEARS, SLAUGHTERED IN NOVEMBER 1974

In 1964-1966, the plutonium concentration in the lung of reindeer was only slightly higher than in that of elk. Instead, the plutonium concentration in the liver of reindeer was 10-50 times, and in bone 5-20 times higher than in those of elk apparently due to the greater dietary uptake of plutonium by reindeer. Assuming that reindeer feeds about 600 kg of lichen (dry wt.) during eight winter months the total dietary intake in its life-time was estimated. The ratio of the sum of plutonium in reindeer liver and bone of reindeer to the total dietary intake was  $5 \times 10^{-7}$ . This gives a rough estimate

Year	Animal		pCi/kg fresh wt		$^{241}\text{Am}/^{239,240}\text{Pu}$
	Age years	sex	$^{241}\text{Am}$	$^{239,240}\text{Pu}$	
1974	13.5	♂	$1.2 \pm 0.1$	$7.1 \pm 0.2$	$0.16 \pm 0.02$
1975	8	♀	$1.3 \pm 0.2$	$8.2 \pm 0.6$	$0.17 \pm 0.02$
1976	2	♂	$0.8 \pm 0.1$	$2.4 \pm 0.1$	$0.20 \pm 0.04$
1976	3	♀	$0.3 \pm 0.1$	$1.3 \pm 0.1$	$0.22 \pm 0.09$
1976	4	♀	$4.5 \pm 0.1$	$28.3 \pm 1.2$	$0.15 \pm 0.01$
1976	6	♀	$5.4 \pm 0.2$	$31.4 \pm 1.3$	$0.17 \pm 0.01$

Table 2. Am-241 and Pu-239,240 in reindeer liver in Finnish Lapland during 1974-1976. Standard deviation of the radioassay (one  $\sigma$ ) is indicated.

for the absorption of plutonium from the diet. The value for the uptake of plutonium from the gastrointestinal tract in man, given by the ICRP is  $3 \times 10^{-5}$  to  $10^{-4}$  (?).

The concentrations of Am-241 in reindeer liver are given in Table 2. The ratio Am-241/Pu-239,240 was quite constant, 0.18-0.03 (mean value of 6 animals). This is slightly lower than the values 0.22-0.25 reported for integrated fallout in soil in 1973 (6).

In 1975 the dietary Pu-239,240 intake of the Lapps was 10 pCi for men and 16 pCi for women. Based on the Am-241 concentrations in reindeer it was estimated that the corresponding values for Am-241 intake were 2 pCi/year and 1 pCi/year for men and women, resp.

The mean values of Pu-239,240 content in liver, bone and lung of southern Finns (13 subjects) were 0.52, 0.20 and 0.03, resp. Assuming that all plutonium is in these tissues, the body burden of Pu-239,240 varied from 0.44 to 1.02 pCi being 0.75 on the average. The radiation dose due to the  $\alpha$ -radiation of Pu is for the southern Finns 0.3, 0.2 and 0.02 mrem/year for liver, bone and lung, resp.

#### ACKNOWLEDGEMENT

This investigation was supported by the Contract No CE B(11-1)-3011 from the US Energy Research and Development Administration.

#### REFERENCES

- (1) JAAKKOLA, T., MIETTINEN, J.K., TULIKOURA, J. and MESSALO, HELENA, Paper presented at the Third European Congress of the International Radiation Protection Association, Amsterdam, The Netherlands, 13-16 May, 1975
- (2) HOLM, E. and PERSSON, R.B.R., (Proc. Symp. San Francisco, 1975) IAEA, Vienna (1976) 435
- (3) NAITO, K., report UCRL-8748, Chemistry-General, IID-4500 (1959)
- (4) CAMBRAY, F.S., EAKINS, J.D., FISHER, E.M.R. and PIRSON, D.H., A.E.R.E.-R 7832 (1974)
- (5) Global Atmospheric Pu-239 and Pu Isotopic Ratios for 1959-1970, US AEC Report HASL-273 (1973) III
- (6) KREY, T.W., HARDY, E.P., PACHUCKI, C., ROURKEY, F., COLUZZA, J., and BENSON, W.K., (Proc. Symp. San Francisco, 1975), IAEA, Vienna (1976) 671
- (7) The Metabolism of Compounds of Plutonium and other Actinides, ICRP Publication 19 (1972)

## PLUTONIUM CONTENTS IN THE COASTAL ENVIRONMENT OF JAPAN

A. Yamato, M. Kinoshita and Y. Kurokawa

Power Reactor and Nuclear Fuel Development Corp.  
Tokai works, Tokai, Ibaraki-Ken, 319-11 Japan

## 1. INTRODUCTION

The Japan islands are situated in a band with much fallout (2) from 25°N to 45°N in Northwest Pacific Ocean and it is important to investigate environmental radioactivity. In many radioactive nuclides in the environment, most of them were introduced by atmospheric nuclear tests, recently plutonium has become to be paid much attention as a toxic transuranic alpha-emitter (3), and Sr-90 is also one of the most important beta emitters, and is widely distributed in the environment. Few reports were published about contents of plutonium in the environment and fallout amounts in Japan. (1) The objects of this study are to survey amounts of Pu-239 and Sr-90 in the Japan islands and to establish characteristic distribution and relations between them in miscellaneous environmental samples.

## 2. METHOD AND MATERIALS

Sample collection and preparation.

Soil: Soil samples were collected by pushing a 8cmϕ×10cm depth cylindrical sampler into the ground, in Ibaraki prefecture, then dried at 110°C, and sifted out larger grain than 2mm.

Vegetation : Some vegetables and pasture grass were collected and removed the root, then ashed in a furnace at 550°C.

Sediment : Sediment samples were collected using dredges around Japan islands, especially many samples from off-shore of Ibaraki pref.. They were treated in the same way with soil.

Fish and seaweeds : These samples were collected in the area of off-shore of Ibaraki pref.. Treatment of them were same with vegetations.

Determination of Pu-239,240 (6); Plutonium seawater and spiked Pu-236 was coprecipitated with Fe(OH)<sub>3</sub>, then the precipitation was collected and dissolved with 8N nitric acid. Other samples with Pu-236 spike were boiled with nitric acid to leach the plutonium, filtered off the residue then adjusted the concentration of nitric acid to 8N. Plutonium was purified through anion exchanger, with the acidity of 8N HNO<sub>3</sub>, 10N HCl-0.1N HI sequentially, then electrodeposited on a stainless steel disc and determined by means of alpha-spectrometry with Si-SSD connected to a pulse height analyzer.

Determination of Sr-90;

Strontium-90 was leached from samples by boiling with nitric acid then precipitated from the leachant with oxalic acid. Strontium fraction was purified through many precipitation steps. The purified strontium solution was kept for two weeks to grow Y-90, then Y-90 was separated and the beta activity was measured. An aliquot of stable strontium was added to all samples prior to the analysis, and the recovery was measured by atomic absorptiometry. Recovery of yttrium carrier was also measured.

## 3. RESULTS AND DISCUSSION

The contents of Pu-239,240 and Sr-90 in the samples collected on land are

listed in TABLE-1.

sample	Pu-239,240 (pCi/kg-fresh)*			Sr-90 (pCi/kg-fresh)			Pu/Sr ratio (%)
	average (range)	samples	ratio to soil	average (range)	samples	ratio to soil	
Soil	18.5 (2-49)	21	-	495 (76-1450)	29	-	3.7
Pasture grass	204 (43-193)	6	0.011	38 (20-60)	5	0.077	0.54
Spinach	93 (18-160)	3	0.005	27 (25-29)	3	0.055	0.34
Cabbage	9.5 (6-13)	2	0.0005	7.1 (5-9)	2	0.014	0.13
Chinese cabbage	10.3 (0.2-33)	9	0.0006	36 (6-33)	6	0.032	0.06

TABLE 1. Plutonium-239,240 and Strontium-90 contents in environmental samples.

\*; Unit of Pu-239,240 in soil is pCi/Kg-dry.

The range of Pu-239,240 contents is wide as from 1.4 to 49 pCi/Kg-dry, the reason of this wide range may concern with the composition of the soil which is mixture of sandy part, red clay part and others. A typical profile of Pu-239,240 and Sr-90 in these soil is shown in FIG. 1. About 75% of Pu-239,240 is maintained in top 10 cm layer of the soil, and less amounts of Pu-239,240 is immigrated into deeper layers.

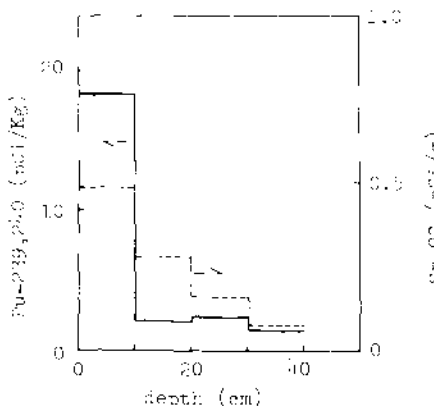

FIG. 1. Typical profile of Pu-239,240 and Sr-90 in soil.

On the other hand, only about 50% of Sr-90 is kept in top 10cm layer and residual part of Sr-90 is incorporated into deeper layers.

Both Pu-239,240 and Sr-90 in plants are also determined. Rather higher contents of Pu-239,240 is gained in such leafy plants as pasture grass and spinach, as a trend, on the contrary lower values are found in cabbage and chinese-cabbage. The percentage of Pu-239,240 concentration in plants to that in soil is calculated to be higher values of  $5-11 \times 10^{-3}$  in such leafy plants and lower values of  $5-6 \times 10^{-4}$  in cabbaged ones. The percentages of Sr-90 are rather constant values in the range of  $1-8 \times 10^{-2}$ .



The reason of the difference of those values could explain as follows. Strontium is assimilated into plants with calcium which is abundant in environment and one of the indispensable elements for plants, on the contrary plutonium may be not essential element for them, moreover strontium is easily soluble in water, but plutonium is not. Therefore, the important pass of the contamination by fallout Pu-239,240 to plants is deposition or adsorption onto the leaves of plants than other passes such as absorption of Pu-239,240 from soil. The ratios of Pu-239,240 to Sr-90 in plants are ranged from 0.06 to 0.54%. Plutonium-239,240 and Sr-90 in marine environment are also investigated, and the results are set in TABLE 2.

sample	Pu-239,240 (pCi/Kg-fresh)			Sr-90 (pCi/Kg-fresh)			Pu/Sr (%)
	contents average (range)	samples	ratio to seawater	contents average (range)	samples	ratio to seawater	
Sea water	0.69 (0.3-1.2)	6	-	0.27 (0.16-0.42)	31	-	0.23
Flounder (fillet)	15.8 (9-31)	6	25	0.56 (0.3-1.1)	6	2.1	2.8
Anchovy (whole)	30.7 (15-86)	11	50	0.69 (0.2-1.8)	11	2.6	4.4
Wakame	113 (21-194)	4	180	3.1 (2.2-4.6)	4	11	3.5
Hijiki	228 (120-330)	5	370	2.1 (1.4-2.8)	5	7.9	11
Sediment*	15.6* (4-64)	93	$2.5 \times 10^4$	4.5* (0.4-13)	55	17	350

TABLE 2 Plutonium-239,240 and Strontium-90 in marine samples.

\*; Sediment is analyzed in dry base, and the unit is pCi/Kg-dry for both Pu-239,240 and Sr-90.

Sea weeds indicated higher contents of Pu-239,240 than fish. Concentration factors for Pu-239,240 and Sr-90 of these samples were shown in the fourth and seventh columns of TABLE 2. One of the most important reservoirs of Pu-239,240 in the marine environment is sediment and the concentration ratio to seawater is attained to the highest value of  $2.5 \times 10^4$ , this value can be compared with Kd value reported by Hijiiri et al (4), and percentage to Sr-90 was 340 indicated largest value. The reason why Pu-239,240 is concentrated in sediment is that if the chemical form of the fallout Pu-239,240 is insoluble particles of Pu<sub>2</sub>O<sub>3</sub> and have

about 10 Å diameter (5), the sinking velocity in seawater could be calculated by Stokes' equation to be about 2000 m/yr. Therefore most of plutonium is settled on the bottom especially such shallow water area within very short time after it is introduced into marine environment. The contents of Pu-239 in sediment collected around Japan islands are shown in FIG. 2.

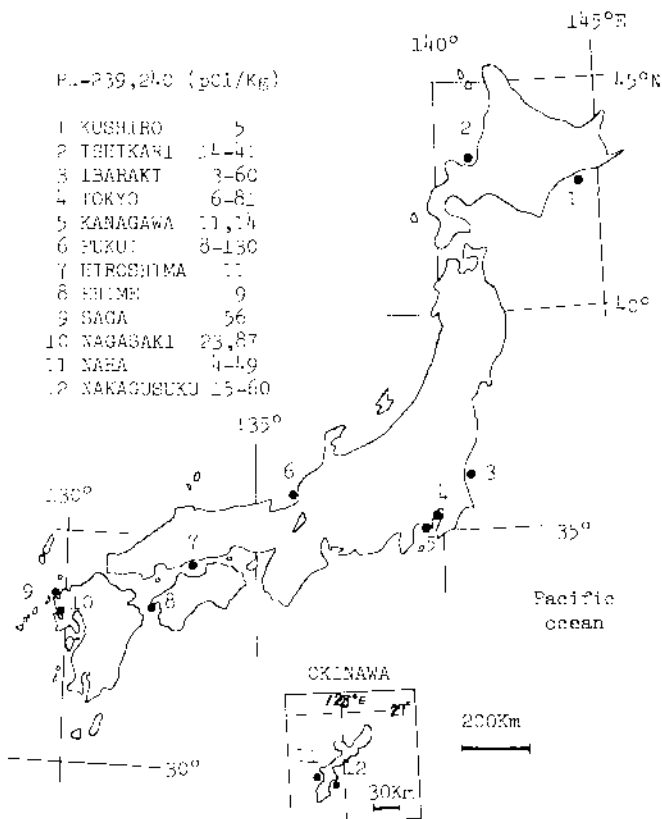

FIG. 2 Plutonium-239,240 and Sr-90 in shallow water sediment around Japan.

#### REFERENCES

- (1) Sakamoto M. et al, IAEA-EM-148/54 P 171 (1971) ; Miyake Y. et al, Pap. Met. Geophys. 26 1 (1975) ; Imakuma Y. et al, FNCI-75-02, 195 (1975)
- (2) Hardy E.P. et al, HASL-250 (1972)
- (3) Proc. Symp. Transuranium Nuclides in the Environment. IAEA-EM-199 (1976)
- (4) Pillai K.C. et al, IAEA-EM-199/27 (1976)
- (5) Sill C.W., Health Phys. 29 619 (1975)
- (6) Suzuki S. et al, Determination of picocurie amounts of plutonium. IAEA Proc. Series 821/PUB/159 35(1967)

## MEDICAL EXPOSURE : GROWTH WITH RESTRAINTS

R. E. Ellis B.Sc. Ph.D.

Department of Medical Physics,  
University of Leeds,  
EnglandINTRODUCTION

The demand for examinations and investigations involving the use of X-rays and radioactive isotopes is increasing both in the technologically developed countries as well as those countries where medical facilities are limited to the major population centres. The annual growth in the latter countries reflects the demand for improved medical care and is controlled mainly by the rate of providing new X-ray and isotope equipment. Such growth is to be encouraged; yet in all countries there is an awareness that medical exposure to radiation needs controlling and if possible reducing so that the incipient risks are minimised as the benefits of modern health care accrue.

This review of published and unpublished information presents the trends in demand for medical exposure and places priority to some of the areas in which restraints should be applied to control the growth of the population exposure and indicates the order of the risks and the benefit.

X-RAY FACILITIES AND GROWTH RATE

In technologically developed countries the number of X-ray facilities may be about one unit per several thousand of the population. For example, a W.H.O. report ( 1 ) gives one per thousand in the U.S.A. and in the U.K. there are 1148 departments of radiology with an average of about 7 X-ray units per department (excluding dental units) which is 1 X-ray Unit per seven thousand population. By contrast the W.H.O. reports for Eastern Mediterranean countries one X-ray unit per 72,000 and in Burma there is one unit per 143,000 of the population. Therefore there is a range of about 100 to one in facilities and this is reflected in the film consumption of 2.46 films per person/year in the U.S.A. to 0.063 films per person year in the Eastern Mediterranean countries, (a factor of about 40 to one). The effect of the variation of the frequencies of examination in various countries may be seen from the results of recent surveys of the population genetically significant dose and mean marrow dose estimates which are shown, in increasing frequency order per thousand of the population, in Tables 1 and 2. Even so particular practises, for example mass screening of the stomach in the Japan studies, may introduce particularly high exposures; in a similar way greater emphasis in some countries on the need to reduce the doses during examinations may lead to lower population doses (e.g. Japanese 1969 and 1974 studies), or at least to less than a proportionate increase when the frequency of examination increases (See Tables 1 and 2).

The annual rate of growth of radiological examinations in the early 1960's has been shown to be about 2 - 6% in the technologically developed countries, however, recent information ( 2 ) for the late 1960's and early 1970's would indicate that for many countries this annual rate of growth has increased to between 5 and 15% (Table 3). The rate in Japan would appear to have slowed down even though some important examinations from a dose viewpoint have continued to increase considerably, e.g., the frequency/1000 of barium enema examinations has risen from 19 to 86 to 108 in the years 1959, 69 and

74 respectively so also have abdomen, lumbar and sacral spine and dental examinations.

The increase in radiology goes with an increase in many aspects of medical care as is seen in Figure 1 based on tests carried out in the National Health Service of the U.K. Radiology and Pathology would appear to have increased at the same rate in the U.K.

#### RADIOISOTOPE FACILITIES AND GROWTH RATE

An even greater growth rate is occurring in the use of radioactive isotopes in clinical medicine for diagnostic purposes. In contrast to the X-ray situation the annual frequency of examination in most countries is only about 10 investigations per thousand (Table 4). However, the rate of growth in some technically developed countries is such that a doubling of the number of investigations is occurring every two to three years i.e. an annual rate of growth of 26 - 41%. More information is required to get a world wide view. An illustration of the way in which the growth of a specialty is linked with the installation of new equipment is given in Figure 2. The number of imaging procedures in the U.K. increased as the number of scanners and  $\gamma$ -cameras were installed.

The conclusion from these data is that considerable growth is occurring in both X-ray and radioisotope investigations both in technologically advanced as well as in developing countries, therefore appropriate restraints must be applied in both the conduct of the examinations as well as in the dose per examination so that the population doses are kept to the minimum.

#### WHAT ARE THE BEST AVAILABLE RESTRAINTS?

Education is the key to all the possible restraints and the three groups that need educating in different ways are:-

- 1) the clinicians who originate the requests for the examination.
- 2) the general public who are the patients and their relatives.
- 3) the medical, scientific and technical staff who undertake the investigations and examinations.

#### 1. The Clinicians

The three questions that need to be asked are; is the examination necessary? is there an alternative test not involving radiation and finally has the examination been conducted recently elsewhere?

The control of those requests that are ordered as a routine by junior doctors or as a medico-legal safeguard is difficult but all senior radiologists agree that there are clinically avoidable examinations. The answer would appear to be that radiologists should persuade their colleagues to introduce a system of reviewing the practice of their junior staff and teaching about this problem in the medical curriculum. Ultrasound scanning is one of the important alternative tests available and its use particularly in obstetrics should reduce the number of X-ray examinations undertaken during pregnancy to investigate the foetus.

In a U.K. survey in 1973 (3) the percentage of deliveries X-rayed was 22.7%, however, in 1976 a survey in Yorkshire with a population of 3.5 million showed only 8% were X-rayed. In this region during the period 1972-76 sixteen

ultrasonic B scan apparatus were installed each of which is capable of supporting the work involving about 3,500 pregnancies. It is vital that a more extensive use of ultrasonic scanning is made to replace X-ray investigations of the mother and foetus. In the Yorkshire Survey it is also interesting to note that in Obstetric Abdomen X-ray examinations only one in eight patients have 2 films all others only one and in Pelvimetry examination only one in three have 2 films. This is a marked reduction to the practice in 1957 when one in three had 2 films for Obstetric Abdomen and everyone (on average) had two films in Pelvimetry.

The transfer of films from one hospital to another does not appear to be an easy system to introduce in the U.K. It would be interesting to know whether this is easier in a country with more private practice in radiology.

## 2. The Public

The public need to be conversant with the principle that it is undesirable to irradiate an early embryo or foetus. The 10 day rule has focussed attention on the need to ask the question as to whether the patient is likely to be pregnant or not.

Examinations are still being carried out when the first indications of pregnancy are seen on the films or are reported too late by the patient (4). In the Yorkshire Survey 88% of the hospitals were working the 10 day rule for women in the 15 to 50 year age groups who were reporting for X-ray examinations. The introduction of this system into radioisotope departments is however less advanced. The half life of the isotopes does however make it of less significance but for some short lived radiopharmaceuticals and for all therapy using radioisotopes the question of pregnancy is important (5).

## 3. The Radiologist and his staff

The radiological staff need to study and implement, in the following priority order, ways of:-

- a) Reducing the number of films taken per examination, including retakes.
- b) Reducing the dose given to each film by using the fastest screen film combination that is appropriate.
- c) Reducing the dose given in each fluoroscopic screening session by using minimum exposure periods and well maintained image intensifiers.
- d) Reducing the field size.
- e) Reducing the gonad dose by using gonad shields.

### a) Reducing the number of films

The best method of reducing the dose is to cancel the examination altogether but usually the radiologist must, as has been shown in the section on the clinician, consider the possibility of reducing the number of films per examination by a careful assessment of the needs of the examination and the way that alternative methods of investigation, such as ultrasound or isotope investigation, may be substituted. The introduction of CT scanning of the head has enabled in many centres a reduction to 20-40% of the numbers of

carotid angiograms, ventriculograms and brain isotope scans.

A recent British Institute of Radiology Survey (3) has drawn attention to the fact that one patient in seven who undergoes X-ray examination has at least one film spoiled and retaken. The principal cause is an exposure fault which accounts for about two thirds of the spoiled films and one fifth due to positioning faults. Many of the exposure faults were with films taken with portable radiographic equipment and this raises the question of the desirability of providing automatic exposure control in new X-ray apparatus which has estimated to add 17-20% of the cost of the total installations. More complex automatically programmed equipment designed to eliminate most operator errors, as distinct from incorrectly positioning of the patient, would add 27-30% of the cost of the complete installation. The saving in the genetically significant dose would be about 5% if all retakes were eliminated.

#### b) Reducing the dose per film

The introduction of rare earth intensifier screens is yet another step in the production of faster screen film combinations which allows the examinations to be conducted with about half the radiation doses. The Yorkshire Survey in mid 1976 shows however that only very few of these rare earth screens have been purchased in the U.K. Out of 40 departments, 23 had no rare earth screens, 8 between 1 and 5%, 5 between 5 and 10%, 3 between 10 and 15% and only 1 department had 25% of their total cassettes converted. The principal cause of this slowness to take advantage of this considerable reduction in dose is the estimated cost of £110 per pair of screens. Larger departments may have 50 to 100 cassettes and the B.I.R. estimated that the cost would be £1.5 million over the whole of the U.K. Some 90 per cent of the genetically significant dose from diagnostic radiology in the U.K. is estimated to be from radiography so that a total of 12 mrad for a population of 55 million might be reduced to 6 mrad, a net saving of 330,000 man rad each year. As the National Radiological Protection Board have indicated this is a cost of about £4.5 per man rad. A similar calculation based on the fact that about 60% of the per caput mean bone marrow dose is from radiography (excluding photofluorography) shows that the mean marrow dose could be reduced by 7.5 mrad - a net saving of 410,000 man rad i.e. a cost of less than £4 per man rad. These costs per man rad reduced are low compared with the calculations of the cost to reduce the dose to occupationally exposed workers of between \$10 - 250 (6).

#### c) Reducing the dose in fluoroscopy

The image intensifier was heralded as the means of reducing dose to the patient during fluoroscopic examinations by a factor of 10 but as radiologists took advantage of being able to conduct their examinations under normal lighting conditions the average X-ray tube current reverted to the 2-3 mA that was used previously before image intensifiers were available. Subsequently with television display and automatic brightness controls some radiologists and their electronic maintenance staff have ignored the need to keep the radiation dose rate down and X-ray tube currents have tended to increase. This trend has been well demonstrated by Gustafsson (7) who reports that in barium enema examinations the energy imported has increased by a factor of two between 1960 and 1974. It is necessary to reverse this trend. The other problem is that as the intensifier tubes age their efficiency decreases and X-ray tube currents up to 6 mA may be required to get sufficiently bright images. The aim should be to replace these intensifiers as soon as the mean X-ray tube current during an examination exceeds 2-3 mA. The new techniques of pulsed fluoroscopy with electronic retention of the

visual image should be a means of decreasing these doses by a factor of five.

An illustration of the high doses delivered in cardiac catheterisation and the way that these correlate with the exposure in mA x sec is shown in Figure 3.

#### d) Reducing the field size

The risk of inducing deleterious effects is obviously a function of the fraction of the body irradiated and therefore the need to reduce beam size to the minimum needs to be encouraged. The surveys in the U.S.A. have shown that the beam area in terms of the film area have reduced from 1.9 to 1.2 in the years 1964 to 1970.

#### e) Reducing the gonad dose

The greatest reduction in gonad dose occurs when the gonads are shielded from the direct radiation beam. However, shields cannot often be used in examinations of the pelvis in women. The overall reduction in the genetically significant dose by the use of gonad shields has been estimated to be about 20% and therefore their use should be encouraged.

### THE STAFF IN NUCLEAR MEDICINE

The need to use the minimum activity per investigation consistent with satisfactory information needs emphasising. Most investigations can be undertaken within the Category II of the W.H.O. recommendations (8) i.e. An organ dose of 0.25 - 2.5 rad or a whole body dose of less than 500 mrad. One of the exceptions is the use of  $^{131}\text{I}$  for thyroid uptake tests. Now that 'in-vitro' T3 and T4 tests are available to assess thyroid function the practice of measuring  $^{131}\text{I}$  uptake should be discontinued. This would result in a reduction by one third of the gonad doses received by the public from the diagnostic use of radioisotopes.

### BENEFITS AND RISKS

The justification of the use of X-rays and radioactive isotopes in clinical tests is in the benefit that obviously occurs when it is the direct means leading to the diagnosis or a measure of the progress of a clinical condition. What is more open to question is the requirement for those examinations which are complementary to others not involving radiation. It is therefore necessary to attempt to quantify the benefits as well as the potential risks.

The benefits of public mass surveys have been reported e.g. in the U.K. 1968 chest survey of 4.3 million people the following cases were diagnosed: 17,569 pulmonary tuberculosis, 3,503 lung cancers, 10,161 cardiac abnormalities and 3,741 pneumoniosis. In a similar survey in Japan in 1968 covering 40 million people some 44,500 cases of pulmonary tuberculosis were diagnosed. Based on available data on risks at high doses this irradiation was estimated to cause 46 leukaemias and 7 lung cancers (9). Kitabatake (10) has also studied the mass surveys for cancer of the stomach in Japan during 1973 involving 2.2 million people in which 2,423 gastric cancers were identified, of whom 1042 were expected to survive more than 5 years. The risks from radiation induced cancers in these people was estimated as 30 leukaemias and 15 abdominal cancers over the next 25 years - an overall risk of 20 per million compared with about 1 in a thousand of gastric cancer.

The tissues of the body particularly at risk are the ovaries and testes from a genetic viewpoint and the bone marrow, thyroid, breast and lung from a somatic risk. The radiological tests contributing 60-95% of the doses to these organs and tissues are examinations involving the abdomen pelvis and hips for the gonads; barium meals and enemas and examinations of the chest and spine for the bone marrow; head, dorsal spine and chest for the thyroid; chest and urography for the breast; and chest and dorsal spine for the lungs. (Based on the report by Bengtsson (11)).

To assess the risk from low doses, 1 to 10 rad, it is necessary to use the data derived from high dose (100-2000 rad) data summarised by UNSCEAR (12). This unavoidably leads to unknown errors. By expressing the dose received by each irradiated group by the collective dose to a particular tissue at risk i.e. the sum of the products of dose x number of people exposed, it is possible to illustrate the known risks in terms of the number of excess leukaemias and cancers detected for the various collective doses to known groups. This is shown in Figure 4 and it represents the total of our knowledge of long term risks from medically irradiated groups.

There is a considerable spread of values but nevertheless they can be used to estimate the range of deleterious effects. For example, if the per caput bone marrow dose is 50 mrad in a population of 60 million the annual collective dose to the bone marrow would be 3 million manrad. The risk in terms of excess cases of cancer would be estimated to be in the range 10-100 i.e. a risk of 1 in a million.

Obviously groups can only be used to study exact values of risk if they are of sufficient size and followed long enough and Table 5 gives the values deduced by Goss (13) of the size of groups necessary to obtain a 95% probability of the increased risk being identified with a 5% significance. A number of such groups need particular study especially those involving children and where repeated studies may be undertaken e.g. children with orthopaedic handicaps, foetal irradiations, patients with chronic kidney or intestinal disorders.

It is only by constant rigorous care that the radiation dose to the public from medical radiology will be minimised and in this way the risks remain small compared with the benefits.

- 1) Gomez Crespo G et al Proc 3rd IRPA Washington 1973 1133-1138 USAEC CONF 730907 P2.
- 2) Puijlaert CBAJ in Symposium Otaniemi Aug.1972, Thieme-Verlag Stuttgart 1974.
- 3) Royal Commission on Environmental Pollution 6th Report Sept '76 207-211 HMSO Cmdd 6618
- 4) Neumeister K. SAAS der DDR Report SAAS 203. 1976
- 5) Ellis et al. Brit. J. Radiol. 1977 (in press)
- 6) I.C.R.P. Publication 22 Pergamon Press Oxford 1973
- 7) Gustafsson M IRPA Congress Amsterdam 1975
- 8) WHO Report WHO/RHL/73.1 Geneva 1972 Abstracted in B.I.R. Bulletin Vol.1, 2,4-6 1975.
- 9) Kitabatake T et al Radiology 109, 37-40, 1973
- 10) Kitabatake T et al Strahlentherapie 146 (3) 352-358, 1973
- 11) Bengtsson G et al Swedish Institute of Radiation Protection SSI 1976-013, 1976
- 12) United Nations Scientific Committee on Effects of Atomic Radiation 1972 II
- 13) Goss S Health Physics, 29, 715-721. 1975



Year		Exam/10 <sup>3</sup>	GSD mrad
72	India	35	1.1
72	Taiwan	53	3-4
72	Iraq	150	52
73	Puerto Rico	542	46
70	Romania	560	28.5
70	U.S.A.	669	20
74	Japan	1099	17.8
72	Netherlands	1186	28
71	Switzerland	1350	42.9
74	FRG Hamburg	1530	41

Table 1  
Annual Frequency of X-ray Examination  
and G.S.D.

	%/y	Period
Netherlands	8½	1960-70
Sweden	6-8	1972
Sweden	2 <sup>+</sup>	1955-74
Sweden	6 <sup>x</sup>	1955-69
Sweden	20 <sup>x</sup>	1969-74
U.S.A.	7	1972
France	10	1987
Germany	10	1968
Belgium	15	1965-70
U.K.	5 <sup>*</sup>	1960-71
Japan	10	1959-69
Japan	3	1969-74

- <sup>+</sup> Excluding dental exams.  
<sup>x</sup> Dental exams. only.  
<sup>\*</sup> Units of practice not exams.

Table 3  
Annual Rate of increase in  
Radiological examinations

Year		Exam/10 <sup>3</sup>	m.m.d. mrad
57	U.K.	375	32
64	U.S.A.	498	83
70	U.S.A.	559	103
74	Sweden	650	90
60	Netherlands	680	30
69	Japan	641	189
74	Japan	729	127

Table 2  
Annual Frequency of X-ray Examination  
and population mean marrow dose

Year		Exam/10 <sup>3</sup>
73	U.K.	2.0 <sup>+</sup>
73-74	Denmark	9.6
73	G.D.R.	8.0
74	G.D.R.	9.9
68	Sweden	6.0
74	Sweden	11.4
74	FRG (Berlin)	13.9
75	FRG (Berlin)	32.3

<sup>+</sup> Imaging only

Table 4  
Annual Frequency  
of Radioisotope investigations

	Collective Dose man rad	
	Children	Adults
Cancers	310,000	100,000
Leukaemia	310,000	100,000
Thyroid <sup>+</sup>	700,000	-
Breast <sup>x</sup>	-	420,000
Lung		4M
Others	310,000	12M
	<sup>+</sup> incidence	<sup>x</sup> female

Table 5  
Size of collective dose to detect risk  
(95% probability at 5% level)  
Follow up Children 10y Adults 20y.

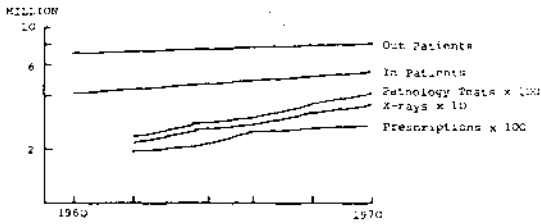

Fig.1  
X-ray and pathology tests of patient attendance in the National Health Service (from Medicine and Society, Office of Health Economics (1972))

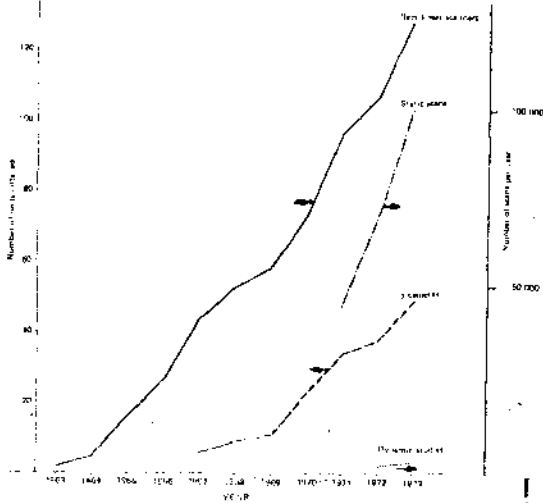

Fig.2  
Number of scanners and v-cameras installed in the United Kingdom 1963-1973, and total number of static scans and dynamic studies carried out 1971-1973

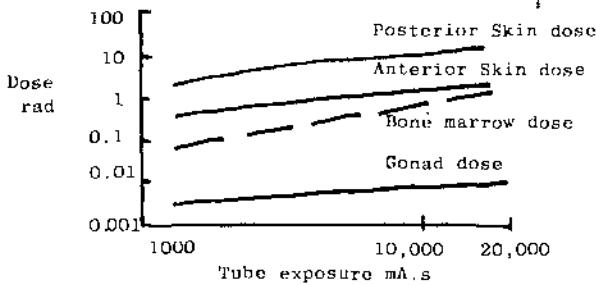

Fig.3  
Dose measurements in cardiac catheterisation

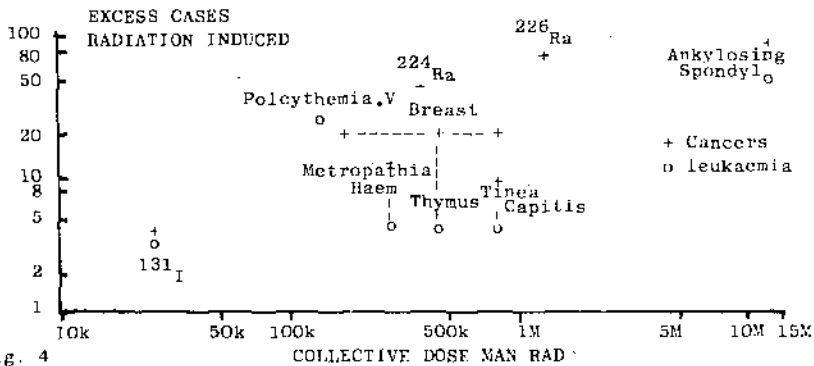

Fig. 4

MEASUREMENTS OF RADIATION DOSES IN DIAGNOSTIC  
APPLICATIONS OF TC-99m

H. Frischauf, K. Kletter, R. Nowotny.

1st Dept. of Medicine, University of Vienna and Inst. f. Radiumforschung  
u. Kernphysik, Vienna, Austria.

1. INTRODUCTION.

The radiation burden induced by incorporation of radioactive substances was hitherto determined mainly by calculation /1/. Such an approach is based on certain assumptions regarding geometrical and kinetic data of the organs under investigation. In particular a simplified approximation for the size and shape of the organs /2/ and their relative positions must be adopted. Furthermore a conception must be formed for the kinetics of the radionuclide or the labeled compound, i.e. distribution and localisation, metabolic turnover and excretion. It is evident that these simplifying and generalizing assumptions may cause gross errors in the evaluated dose. Thus it is difficult to judge on the influence of geometrical variations particularly in children /4/ since dose is calculated on the basis of a "standard man". With respect to kinetic parameters normal and pathological changes of metabolism and excretion can produce large deviations in dose from the estimate /3/. As it seems desirable to limit the number of assumptions in the determination of radiation exposure we tried to devise a method for an individual measurement. We used TLD as dosimeters for their small size, high sensitivity, mechanical stability and tissue equivalency. Technetium-99m was chosen as radionuclide for this study because of its numerous diagnostic applications and a simple decay scheme.

2. METHODS.

The dosimeters were lithium fluoride (TLD-100, Harshaw) chips (1/4" x 1/4" x x 0,035") and rods (1 mm  $\phi$  x 6 mm). They were calibrated in a standardized geometry with Tc-99m the activity of which was determined in a dose-calibrator to  $\pm 5\%$ . A Remcal-Nuclear phantom from Alderson was taken for standardization measurements. Dose measurements were made on patients who were referred for scintigraphy of the liver (10 cases) and the thyroid (7 cases). Uptake and distribution of activity in the organs investigated were determined by a Pho-Gamma-III camera and a linear scanner. The phantom was filled with water. Activity was administered to only one of the following volumes: liver, spleen, thyroid and trunk. A variable thickness of adipose tissue was simulated by several layers of vaseline. Surface dose was measured with chips while rods were inserted into the various volumes. Dosimeters at the surface were arranged in a grid around the body thus covering the organs of interest. This grid was composed of squares with 4 cm length each for liver and spleen, 2 cm for the thyroid resp. Besides dosimeters were located on the phantom and on patients in a variable distance from the organ under investigation to evaluate the contribution to dose from other parts of the body. The position of the dosimeters in relation to the organs was established by markers in the scintigram. Scintigraphy of liver and spleen was performed by application of 4-8 mCi Tc-99m-sulfur colloid, of the thyroid by 2-3 mCi Tc-99m pertechnetate. Dosimeters on the patient were positioned according to percussion findings. In some cases also the scans taken some minutes after application of the radioisotope were referred to. Dosimeters were fixed in the described pattern around liver and spleen or thyroid. Positions distant to the organs were the acromion for the trunk and the thigh. In thyroid studies additional dosimeters were placed over heart, stomach, kidneys and groins. Time period of measurement was 6-24 h.

### 3. CALCULATIONS AND RESULTS.

For the evaluation of the patient dose we correlated the values of dosimeters in the same position relative to the organ on the patients and on the phantom. In the calculation it was assumed that in scintigraphy of liver and spleen the organ dose is induced by three components: activity in the liver, activity in spleen and a nearly homogeneous distributed activity in the rest of the body. Results of measurement on the phantom indicated that accumulation in spleen and trunk is of little influence on dose values in positions close to the liver. Thus liver dose was determined first from these data. Next the dose values from the acromion area were corrected for contribution from liver activity and an estimate for the trunk dose was found in this way. Finally the splenic dose was calculated after correction for activity in liver and trunk.

With pertechnetate total body dose was evaluated from data of precordial region and acromion. Then the surface dose at the thyroid was corrected for trunk dose contribution and the thyroid dose due to accumulation in the thyroid itself could be determined. Total dose to the thyroid results from this plus the total body dose. Contributions from salivary glands and stomach need not be considered separately.

This regime yielded the following results: the liver dose in the phantom amounts to 0,21 rd/mCi, splenic dose to 1,0 rd/mCi and thyroid dose to 5,0 rd/mCi. These data do not take into account the decrease of the dose near the boundary of the organs and/or body surface. Since dimensions of the liver are larger than absorption half thickness for Tc-99m the resulting error for the total liver dose is small. Homogeneous distribution of activity in the trunk produces dose contributions in the different organs from 0,025 to 0,035 rd/mCi, average surface dose on the trunk was found to be 0,010 rd/mCi. Dose contribution to the spleen by the liver activity was 0,015 rd/mCi, vice versa 0,010 rd/mCi.

(The volumes of the phantom organs were measured to: liver 1650 ml, spleen 130 ml, thyroid 23 ml and trunk (including head) 24 l.)

The data given in table 1 and 2 show a greater decrease of surface doses with increasing thickness of vaseline for positions near the centre of the organ rather than near the contours according to a greater relative change in mean organ depth. Comparison of count rates obtained from the phantom and from patients with the gamma camera demonstrates imperfections in the anatomic imitation. In particular the liver is positioned rather superficially in the phantom. As a consequence all liver data were corrected for a covering layer of 2 cm tissue. Additional corrections were applied due to individual size and weight of the patient.

Table 1

	1	3	5	7	9	11	13	15	17	19
1	20	29	29	26	23	20	17	10	6	9
1(2)	18	28	26	23	20	20	16	-	-	-
1(4)	17	27	25	23	17	28	17	-	-	-
3	26	64	69	57	36	35	23	22	8	13
3(2)	26	51	57	49	29	27	21	-	-	-
3(4)	23	37	43	37	27	25	20	-	-	-
5	17	30	37	35	24	19	15	10	6	10
5(2)	16	29	35	33	23	20	23	-	-	-
5(4)	16	26	30	29	21	17	14	-	-	-

Integral dose at surface of phantom (mrđ/mCi). Activity in the liver. Figures in brackets indicate the thickness of simulated fat in cm.

The arrangement of dosimeter corresponds to a grid of squares (length 4cm). For the positions of dosimeter cf. fig. 1. Each second row and column is given.

Table 2

	13	15	17	19	1	3
2	17	96	252	104	17	6
2(2)	-	78	174	87	-	-
2(4)	-	74	157	78	-	-
3	39	104	476	218	18	10
3(2)	-	78	339	165	-	-
3(4)	-	70	224	146	-	-
4	17	61	139	131	10	7
4(2)	-	52	113	113	-	-
4(4)	-	48	96	87	-	-

Integral dose at surface of phantom (mrđ/mCi) Activity in the spleen. For details see table 1.

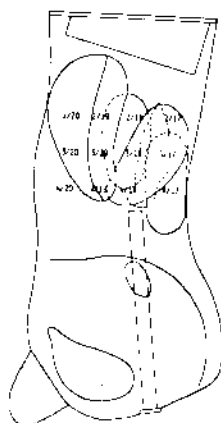

Table 3

Pat.	$\bar{D}$ liver (rd/mCi)		$\bar{D}$ spleen (rd/mCi)	
	measured	calc.	measured	calc.
1	0,14(0,12-0,16)	0,11	0,08(0,05-0,12)	0,08
2	0,18(0,15-0,22)	0,16	0,07(0,04-0,10)	0,09
3	0,15	0,13	-	-
4	0,17(0,14-0,20)	0,15	0,11(0,06-0,15)	0,11
5	0,16(0,14-0,18)	0,11	0,08(0,05-0,13)	0,08
6	0,27(0,16-0,35)	0,20	0,24(0,18-0,30)	0,20
7	0,09(0,08-0,10)	0,09	0,04(0,02-0,06)	0,05
8	0,11(0,09-0,13)	0,14	-	-
9	0,15(0,13-0,18)	0,11	0,17(0,14-0,21)	0,20
10	0,19(0,15-0,21)	0,15	0,15(0,10-0,19)	0,17

Average dose in rd/mCi (range in brackets)  $^{99m}\text{Tc}$  liver and spleen after i.v. application of  $^{99m}\text{Tc}$ -sulfur colloid. For details see text.

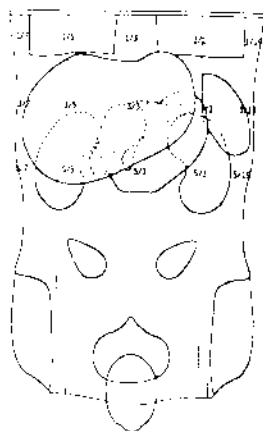

Table 4

Pat.	$\bar{D}$	
	th(rd/mCi)	tb(rd/mCi)
1	0,15(0,11-0,18)	0,025
2	0,14(0,13-0,16)	0,020
2+	0,04(0,03-0,06)	0,022
3	0,15(0,13-0,16)	0,020
3+	0,07(0,06-0,09)	0,020
4	0,08(0,06-0,011)	0,023
5	0,11(0,09-0,13)	0,027
6	0,39(0,35-0,41)	0,020
7+	0,07(0,05-0,09)	0,025

Average dose (rd/mCi) to thyroid (th) and total body (t.b.) after i.v. application of  $^{99m}\text{Tc}$ -pertechnetate. (+) Patients whose thyroid was blocked.

Fig. 1: Position of dosimeters on the phantom. Above: leftside view. Bottom: front view.

Table 3 and 4 give dose values for the patients which were calculated from their surface doses. Conventionally calculated dose values for liver and spleen were obtained by an estimate for accumulation in these organs via count rates from the gamma camera according to /1/. The data for specific absorption given by /2/ for a heterogeneous phantom were used. For the patient no.3 in table 3 only a few dosimeters were evaluable because of positioning difficulties. Patient no.8 was splenectomized (no value for the spleen is given). In patient no.6 the extremely slim constitution may be responsible for the high dose which has not been corrected for. Calculated uptake in this case was found to be higher than 100% of applied activity. The increased scatter in the spleen data may be caused by the easy displacement of this organ within the abdominal cavity. Table 4 gives dose values for the thyroid and total body after application of pertechnetate. For two patients (no.2 and 3) the measurements were repeated after blocking the thyroid. The radiation doses were significantly lower, similarly as in a patient who was examined under thyroid suppression only. Case 6 who exhibited a noticeable high dose burden suffered from definite hyperthyroidism.

#### 4. DISCUSSION.

The direct determination of radiation dose in patients after the administration of radioactive substances has to our knowledge been rarely accomplished. To some extent this might be caused by the fact that uncertainties introduced by geometrical factors are hardly reduced. In these preliminary studies we used a more realistic phantom instead of the "standard man" geometry. We have chosen simple diagnostic procedures concerning the tracer kinetics to verify the usefulness of this approach. The data obtained show good agreement with the values reported in literature. Water as a phantom material is a fairly good general substitute for tissue except for bone and lung. Ground cork was chosen as an equivalent for lung tissue. The phantom provides no facilities for the simulation of bone.

The most important contribution to errors is introduced by the geometrical conditions whereas errors resulting from dosimetry have little effect on the accuracy of measurements. Variation in the depth of the organs was corrected for while size and shape were not considered. Additional studies will hopefully allow a further correction for these sources of error.

An exact description of tracer kinetics in the application of this method is not necessary. It is sufficient to know about the approximate distribution of tracer material to estimate the contribution to the surface dose from various organs. The essential interest of this method is based on the fact that one has not to rely on any kind of kinetic model or data. Therefore it can be expected that this method will yield more reliable data in cases of complex tracer kinetics and will provide a measurement of radiation exposure in individual patients.

#### Literature.

- 1a) Levinger R, M. Bormann : J. Nucl. Med. (MIRD) Suppl. 1, 9 (1968)
- 1b) Elliot W.H., G.L. Brownell, A.R. Reddy: Phys. Med. Biol. 13, 219 (1968)
- 2) Snyder W.S., H.L. Fisher, jr, Mary R. Ford, G.G. Warner: J. Nucl. Med. (MIRD) Suppl. 3, 7 (1969)
- 3) Smith E.M.: Radioactive Pharmaceuticals 6, 649 (1966)
- 4) Kereiakes R.A. et al: Health Physics 11, 999 (1965)
- 5) Smith E.M.: Nuclear Med. 6, 231 (1965)

Radiation Protection Aspects of  $^{131}\text{I}$  Treatment

P.C. van der Pol, radiotherapist  
 Leyenburg Hospital, Dept. of Radiotherapy and Nucl. Med.  
 Leyweg 275, The Hague-2033, Netherlands.

## 1. INTRODUCTION.

Therapy of the thyroid gland with  $^{131}\text{I}$  for hyperfunction, ablation and cancer is a very common procedure since 1942. Bland et al. (1) mentioned that between 1942 and 1970 already 300.000 patients had been treated with  $^{131}\text{I}$ . In the Netherlands the yearly number of  $^{131}\text{I}$ -doses is about 900. The usual dose is + 10 mCi, given orally.

The ICRP provides calculations and recommendations for the normal adult. For the standard man the weight of the thyroid gland is 20 grams, the uptake of iodine 30% and the effective half-life of  $^{131}\text{I}$  is 7.5 days. Recommendations and regulations with regard to the treatment of diseases of the thyroid gland with  $^{131}\text{I}$  are not uniform over the world.

Particularly there is no unanimous opinion over how long a patient, after a certain dose of  $^{131}\text{I}$ , is to be kept in the controlled area of the dedicated ward in a hospital. In America a patient with the given dose of 30 mCi  $^{131}\text{I}$  or less is sent home and not hospitalized. At the end of 1976 the Government of Western Germany published a new regulation: depending on the given dose and the situation at home patients are dismissed from the hospital at the level of 2 mCi, measured at the neck. Under special conditions and instructions patients can be sent home with a remaining dose of 2 - 8 mCi.

At this moment there are in the Netherlands no rules or regulations to cope with this situation.

But, even when one has chosen a standard remaining dose in the neck of the patient, it will always be necessary to perform measurements on the individual patient to see when this standard for dismissal from the hospital is reached or is expected to be reached within certain limits. For the latter procedure it is necessary to get from the individual patient several measurements after oral dose of  $^{131}\text{I}$  and to construct on semilog paper a line that crosses at a certain point the chosen level for dismissal. With this line the  $T_{\frac{1}{2}}^{\text{eff}}$  can be found.

## 2. EFFECTIVE HALF LIFE TIME.

This is the combination of the physical desintegration of the  $^{131}\text{I}$  isotope and the biologic metabolism and excretion of the element. The  $T_{\frac{1}{2}}^{\text{eff}}$  under diagnostic circumstances is extensively studied ( $T_{\frac{1}{2}}^{\text{effD}}$ ). This in contradiction with the  $T_{\frac{1}{2}}^{\text{eff}}$  under therapeutic conditions ( $T_{\frac{1}{2}}^{\text{effT}}$ ). In fact, there are very few publications with data on  $T_{\frac{1}{2}}^{\text{effT}}$ , and usually the period, wherein measuring of the remaining dose in the neck of the patients were done, was short (5 - 10 days). From computed data of Creutzig et al.

(2) it is clear that already over a period of 7 days after respectively diagnostic and therapeutic oral dose of  $^{131}\text{I}$  the  $T_{\frac{1}{2}}^{\text{effT}}$  is half a day longer than  $T_{\frac{1}{2}}^{\text{effD}}$ , whilst also the uptake under therapy is higher than during diagnostic period. The publication of Joyet et al. (3) gives information over  $T_{\frac{1}{2}}^{\text{effT}}$ . Hamilton and Werner (4) took measurements over a period of 4 weeks. Their mean dose was 4 mCi (2 - 7 mCi) and they studied in 4 groups the effects of concomittant antithyroid drugs.

A good knowledge of  $T_{\frac{1}{2}}^{\text{effT}}$  is necessary with regard to radiation protection in the controlled area of the hospital as well as to the period after dismissal of the patient in his own surroundings.

With a long  $T_{\text{eff}}$  the patient is a gamma source and the excretion of the  $^{131}\text{I}$  is low. Is the  $T_{\text{eff}}$  short, then the excretion and the contamination risks become important.

At the same time the hospital ward as well as the patient are involved. They want to know the expected hospitalisation time after certain oral therapeutic dose  $^{131}\text{I}$ .

Before one can give an answer to this question one has to agree on what will be the acceptable value of the remaining activity in the thyroid gland of the patient at the moment of dismissal.

A long period in the hospital is expensive and may lead to greater radiation risks for the nurses, whereas a patient with high rest thyroid values is put back in the community as a gamma source and potential beta contamination source.

From the point of view of radiation protection the latter situation forms the basis for limitations in the determination of the moment of dismissal. To reach this point the help of a mathematical model is needed.

### 3. MATHEMATICAL MODEL.

The yearly permitted exposure for a radiological worker is 5 Rem. For the population at large this exposure is one tenth, e.g. 0,5 Rem a year. This gives a permitted continuous exposure per day of  $0,5 : 365 = 1,37 \text{ mRem}$ . In this model 1 Rem is stated 1 R. In the literature a point source of 2 mCi  $^{131}\text{I}$  gives an exposure varying from 0,22 - 0,265 mR per hour at one meter. The tissue half value layer for the gamma radiation of  $^{131}\text{I}$  is 6,2 cm (5). It is recognised that the thyroid is not a point source, but the overlying tissue is very thin.

If a remaining dose of 2 mCi in the neck of the patient is taken as standard before dismissal then this dose will give an exposure of 12 mR per hour at one meter. During a night of 8 hours the partner receives 4 mR. Analysis of the data of Buchan and Brindle (5) gives an exposure of 1 mR per 2 mCi for every member of the family during the day. The partner is per 24 hours exposed to  $2 + 1 = 3 \text{ mR}$ . When different circumstances as single and double beds are taken into account, an exposure of 4 mR per 24 hours is reasonable. With a  $T_{\text{eff}}$  of 7 days and dismissal at 2 mCi the partner receives:

4 mR on the 1st day, the 2nd day 3,5 mR, the 3rd day 3,2 mR, the 4th day 3 mR, the 5th day 2,75 mR, the 6th day 2,5 mR and the 7th day 2 mR.

The sum of the 1st week is 21 mR (50%), 2nd week is 10,5 mR (25%), 3rd week 5,25 mR (12,5%) and the 4th week 2,625 mR (6,25%).

The sum of the 1st and 2nd week is 31,5 mR (75%); the sum of the 1st, 2nd and 3rd week is 36,75 mR (87,5%). The sum of 4 weeks is 39,38 mR (93,75%).

The exposure that is allowed to the partner as member of the population

is in:

1 week	: 7 x 1,37 mR = 9,59 mR - received 21 mR = 2,19 times
2 weeks	: 14 x 1,37 mR = 19,18 mR - received 31,5 mR = 1,64 times
3 weeks	: 21 x 1,37 mR = 28,77 mR - received 36,75 mR = 1,38 times
4 weeks	: 28 x 1,37 mR = 38,36 mR - received 39,38 mR = 1,03 times

The average is 1,54 times permitted exposure over a period of 4 weeks.

The other family members stay well below this exposure. From the data of Buchan and Brindle one can see however that the mean age of the girls at home is 14,3 years and of the boys 17,5 years; in fact younger than 18 years. Based upon this reasoning a remaining dose of 2 mCi  $^{131}\text{I}$  in the thyroid of the patient becomes standard for dismissal from the controlled area of the hospital. In the special wards the patients are almost self supporting, and with special instructions the nurse exposure is kept well below permitted levels.



#### 4. MEANS OF MEASURING.

The detector used is a PW 4119 with a 7,5 cm cristal diameter. The collimator is 22,5 cm long and the opening at the end is 10,5 cm. The patient sits at 100 cm distance from the cristal. Counting time for background and patient is 5 minutes each. Corrections for dead time are made. Calibration with a standard-source is done.

#### 5. PATIENT DATA.

On the patients in the group non-malignant thyroid diseases sent for  $^{131}\text{I}$  treatment, as consequently as possible measurements of the remaining dose in the neck were done at 1, 2 and 3 weeks after oral dose. Given doses of  $^{131}\text{I}$  vary between 5 and 30 mCi. The severity of the disease of the individual patient was not considered and the investigations were done to get useful information for radiation protection. Of the 102 patients treated, 97 had useful data. The dose-groups of 5, 6, 8, 10, 12, 15, 16, 20, 25 and 30 mCi consisted of 3 or more patients each. For the doses of 7,5, 18 and 24 mCi there was one patient only. The total number of measurements was 335, with a mean number of 3,45 per patient. From the data of every individual patient a linear plot was fitted on semilog paper. The fitted line was extrapolated to time = 0. The value found on the y-axis is called effective dose and also noted in percentage of oral dose. The time constant and  $T_{\frac{1}{2}}^{\text{eff}}$  were calculated. The cross-point of the fitted line with the 2 mCi level was noted.

#### 6. COMPUTATION OF DATA.

The data in every dose-group were collected and a new mean curve was fitted for that dose. On the 2 mCi level there was a spread of dismissal times and on the y-axis a spread in effective dose. The data of both factors were fed into the computer and standard deviation as well as 70, 80, 90 and 95% borders were calculated. With regard to radiation protection the latter was the most interesting, because the aim was to find the safest dismissal time.

The dismissal times and their limits on the x-axis were plotted on semilog paper against dose-groups (y-axis) and it was possible to make a new fit with these data. The result is a graph that shows the relationship between every dose and mean safe dismissal time.

#### 7. DISCUSSION.

It is clear that discussion is possible on the point of setting the dismissal dose on 2 mCi. So calculations were made for the levels between 1,5 and 5 mCi. At the 4 mCi dismissal level the exposure to family members other than the partner plays a role. From the point of radiation protection one must see a patient with a high  $T_{\frac{1}{2}}^{\text{eff}}$  as a long standing gamma radiation source and a patient with a short  $T_{\frac{1}{2}}^{\text{eff}}$  as a limited gamma radiation source but a high risk for contamination because of rapid excretion of the  $^{131}\text{I}$ . It is to be kept in mind that during the time between excretion and contamination the  $T_{\frac{1}{2}}^{\text{phys}}$  is 8 days. It is also clear that under different household circumstances and good instructions to the patient the dose of dismissal can be adapted.

#### 8. CONCLUSIONS.

Measurements of gamma radiation at the neck of patients treated with  $^{131}\text{I}$

for benign thyroid diseases were done with the purpose to come to rational planning in the special rooms for treatments with open sources in the hospital. This planning has proved to be useful for accepting new patients for treatment and to inform these patients about the expected duration of hospitalisation after oral dose  $^{131}\text{I}$ . Dismissal of the individual patient is accomplished on the data for his own curve. It seems necessary to come to calculate the risk of contamination at home for patients with a short  $T_{effT}$ .

#### 9. TABLE.

For the 2 mCi level is found:		average time	-	70% safe	-	90% safe	
oral dose	5 mCi	-	3,2 days	-	5,4 days	-	6,4 days
	6 mCi	-	4,8 days	-	7,0 days	-	8,1 days
	7 mCi	-	6,2 days	-	8,5 days	-	9,6 days
	8 mCi	-	7,4 days	-	9,7 days	-	10,8 days
	9 mCi	-	8,5 days	-	10,8 days	-	12,0 days
	10 mCi	-	9,5 days	-	11,8 days	-	13,0 days
	12 mCi	-	11,1 days	-	13,5 days	-	14,9 days
	14 mCi	-	12,5 days	-	14,9 days	-	16,2 days
	16 mCi	-	13,7 days	-	16,2 days	-	17,5 days
	18 mCi	-	14,8 days	-	17,2 days	-	18,6 days
	20 mCi	-	15,8 days	-	18,2 days	-	19,6 days
	22 mCi	-	16,6 days	-	19,1 days	-	20,6 days
	25 mCi	-	17,8 days	-	20,3 days	-	21,8 days
	30 mCi	-	19,5 days	-	22,0 days	-	23,5 days

#### 10. REFERENCES.

- (1) BLAIR, W.A., HAYS, M.T., Graves disease in the male. Archives of Internal Medicine 129 (1962) 33.
- (2) CREUTZIG, H., HUNDESHAGEN, H., Ist eine Dosisberechnung für die Radiojodtherapie möglich? 15 5 (1976) 233 Nucl Med.
- (3) JOYET, G., MILLER, M., Essai de dosage rationnel du traitement radioactif des hyperthyroïdes par  $^{131}\text{I}$ . Méthode de dosage et résultats statistiques, Annales Radiol. 2 12 (1962) 21.
- (4) HAMILTON, H.B., WERNER, S.C., The effects of sodium iodide, 6 propylthiouracil and 1-methyl-2-mercaptoimidazole during radioiodine therapy of hyperthyroidism, J. Clin. Endocrin. 12 8 (1952) 1083.
- (5) Radioact. Isotop. in Klinik und Forschung, Strahlentherapie, Sonderband 11 (1974) 197.
- (6) BUCHAN, R.T.C., BRINDLE, J.M., Radioiodine therapy to out-patients, the radiation hazard, 41 12 (1971) 973.

MESURE PAR THERMOLUMINESCENCE DE LA DOSE  
GAMMA DELIVREE A L'UTERUS IN VIVO  
DANS UNE THERAPEUTIQUE A L'IODE 131 DE  
LA MALADIE DE BASEDOW

B. PHILIPPON et J. BRIERE

Centre de Médecine Nucléaire, Service du Pr BERGER  
Hôpital Cardiologique, 59, Bd Pinel, 69003 LYON

Service des Isotopes, Hôpital de Bellevue, 42000 St ETIENNE

## I. INTRODUCTION

Jusqu'à la récente publication de J.S. ROBERTSON et C.A. GORMAN (1), une incertitude règne sur l'ordre de grandeur des doses délivrées aux ovaires dans les thérapeutiques par l'iode 131 de la maladie de Basedow ; on peut citer les valeurs extrêmes de 0.05 rad/mCi administrées (2) et 4 rad/mCi (3) administrées.

La détermination directe est impossible. Nous avons pensé qu'une mesure de la dose gamma, possible par les dosimètres thermoluminescents, serait une approximation valable de cette même dose délivrée aux ovaires, ces organes entretenant avec les organes sources de l'irradiation des relations anatomiques semblables. La simplicité de la thérapeutique à l'iode 131 tend à la faire étendre aux malades en âge de procréer. Des Basedowiennes typiques, avant la thérapeutique, ont donc été sollicitées en vue de l'introduction in utero, à titre expérimental et volontaire, de stérilets porteurs de dosimètres au fluorure de lithium et au sulfate de calcium/dysprosium.

## 2. PATIENTS ET METHODES

Les 10 malades étudiées constituent une série relativement homogène de basedowiennes, la table 1 résume leurs paramètres thyroïdiens utiles dans la dosimétrie :

- pourcentage  $T_f$  de fixation ( $\bar{M} = 75,9 \% \pm 8,6$ )
- constante d'excrétion rénale des iodures  $r_1$ , calculée classiquement suivant  $r_1 = r_2 \cdot (1 - T_f) / T_f$  (4), où  $r_2$  représente la constante de captation thyroïdienne des iodures.
- constante  $r_3$  de sortie thyroïdienne des hormones ( $\bar{r}_3 = 0,21 \% / \text{hr}$ ).

Toutes ces valeurs sont déterminées sur les courbes de fixation des malades. Les doses imposées à la thyroïde sont calculées par la formule de MARINELLI (8) et sont identiques (8000 rads).

Malade	1	2	3	4	5	6	7	8	9	10	$\bar{M} \pm \sigma$
$T_f \%$	71	83	85	84	66	80	87	66	67	70	75,9 ± 8,6
$r_1 \% / \text{h}$	10	34	9	16	47	20	16	25	8	28	22 ± 12
$r_2 \% / \text{h}$	0.12	0.14	0.41	0.18	0.44	0.13	0.20	0.17	0.19	0.18	0.21 ± 0.11

Table 1 : paramètres thyroïdiens des malades étudiées.

Les dosimètres utilisés sont des micro-rods de 1 x 6 mm de  $\text{LiF}$  et de  $\text{CaSO}_4 : \text{Dy}$  (MR LiF6 et MR  $\text{CaSO}_4 : \text{Dy}$  - TELETYPE ISOTOPIES), mesurés par un lecteur 7 300.9 de même marque. La répétitivité des mesures est de  $\pm 6\%$  pour les MR LiF 6 et  $\pm 8\%$  pour les MR  $\text{CaSO}_4 : \text{Dy}$ . Leur étalonnage est effectué par irradiation sous une source étalon de  $^{137}\text{Cs}$  modèle LMRI ECDB.3 délivrant  $1 \text{ R} \cdot \text{hr}^{-1}$  à 1 m. La réponse moyenne est convertie en rads dans les tissus mous (5). Les dosimètres sont fixés à l'intérieur d'un tube souple scellé de polystyrène d'épaisseur 0,6 mm, lui-même fixé sur un stérilet en cuivre, et l'ensemble introduit in utero avant l'administration de la dose thérapeutique. Ils sont retirés un mois plus tard.

La formule de LÖEVIINGER montre que le pourcentage de dose bêta transmis à travers cette épaisseur est inférieur à 9% (pour la transition de 0,606 MeV de l'I 131). Compte tenu également de la diminution de réponse des dosimètres aux électrons de basse énergie (6) et de la localisation des dosimètres in utero, on a estimé pouvoir négliger cette contribution; la dose mesurée est assimilée à la dose gamma seule.

Des mesures sur un fantôme corporel conforme aux recommandations du MIRD (7) ont été réalisées à cet effet: 20 dosimètres implantés dans des localisations anatomiques différentes ont été irradiés dans le fantôme en milieu équivalent-tissus par  $100 \text{ mCi}$  d'I 131 répartis, soit dans la thyroïde, soit dans le corps entier. On a ainsi déterminé expérimentalement les doses gamma absorbées par unité d'activité cumulée ( $S_1$ ).

### 3. RESULTATS

La table 2 montre les résultats des mesures de  $S_1$  sur fantôme

	1	2	3
Organe source (r)	thyroïde	corps entier	corps entier
Organe cible (v)	ovaire	ovaire	thyroïde
$S_1$ rad/ $\mu\text{Ci} \cdot \text{hr}$ mesurée (FLI)	$(8.6 \pm 0.4) 10^{-8}$	$(3.7 \pm 0.3) 10^{-6}$	$(2.8 \pm 0.2) 10^{-6}$
$S_1$ calculée (S) $\beta + \gamma$	$(4.1) 10^{-8}$	$(11) 10^{-6}$	$(9.7) 10^{-6}$
$S_1$ calculée (S) $\gamma$ seul <sup>t</sup>	$(4.1) 10^{-8}$	$(5.2) 10^{-6}$	$(3.9) 10^{-6}$

Table 2 : Valeurs expérimentales des doses absorbées  $S_1$  par unité d'activité cumulée dans le cas de l'isote 131.  
(suivant  $S_1 = \bar{D} (v \cdot r) \cdot mv/Ar = \Sigma A \Delta t \cdot l$ ) (8).

Dans la mesure 1, la distance thyroïde-mammaire est prise égale à 44 cm dans la fantôme, contre 57 cm dans les calculs du MIRD (9) (7). La fraction absorbée  $\gamma$  mesurée est donc plus élevée. Pour les mesures 2 et 3, les valeurs expérimentales sont respectivement 72 et 71 % de la valeur gamma calculée.

Les résultats de la table 3 représentent la dose gamma mesurée délivrée à l'utérus. La dose moyenne mesurée est de 0,15 rad/mCi administré.

Malade	Activité administrée mCi	Dose $\gamma$ mesurée rads	Dose $\gamma$ mesurée rad/mCi	Dose $\beta + \gamma$ calculée (1)	Dose $\gamma$ calculée
1	6.5	0.57	0.09	0.21	0.18
2	3.18	0.22	0.07	0.18	0.15
3	4.7	1.53	0.33	0.30	0.24
4	5.5	1.18	0.21	0.18	0.12
5	3.94	0.93	0.24	0.33	0.29
6	11.9	1.71	0.14	0.20	0.17
7	3.07	0.39	0.13	0.17	0.13
8	3.67	0.63	0.16	0.25	0.23
9	4.2	0.36	0.09	0.22	0.18
10	3.6	0.28	0.08	0.23	0.21
$\bar{\gamma}$	5.06		0.15	0.22	0.19
$\pm$	2.03		0.06	0.05	0.05

Table 3 : Doses gamma mesurées in utero par les MRLIF6 comparées aux calculs de ROBERTSON et GORMAN (1).

On compare ces résultats avec les doses Betty de la référence (1). La moyenne des valeurs mesurées vaut 0,70 fois (+0,34) la moyenne des valeurs calculées. Il existe une corrélation significative entre nos mesures et les calculs ( $r = 0.67 - p < 0.05$ ). On a également comparé les valeurs obtenues simultanément suivant le  $CaSO_4 : Dy$  et le FLi, sur 7 malades seulement. La moyenne des 7 mesures par le  $CaSO_4 : D$  est de  $0.27 \pm 0.10$  rad/mCi pour  $0.14 \pm 0.05$  pour les mêmes mesures par le FLi, soit un rapport moyen ( $CaSO_4/FLi$ ) de  $1.98 \pm 0.45$ . Le coefficient de corrélation entre les 2 types de mesures vaut 0.8 ( $p < 0.05$ ).

## DISCUSSION

L'écart entre  $CaSO_4$  et  $CaF_2$  s'explique par la surestimation de la dose mesurée due à la non-linéarité de la réponse du premier aux énergies inférieures à 100 KeV. Dans ce cas, seul, le  $F_{Li}$  est utilisable en pratique.

En ne considérant que les mesures effectuées avec le  $F_{Li}$ , nous avons pu comparer les résultats aux calculs de (1). Les discordances observées s'expliquent aisément par le schéma compartimental adopté pour le calcul ne peut pas refléter avec exactitude la multiplicité des paramètres biologiques qui interviennent. Ceci justifie d'ailleurs une tentative de détermination expérimentale de la dose gamma.

Les résultats obtenus présentent une dispersion relativement faible. On peut leur accorder une certaine confiance. Les valeurs d'irradiation gammaïque dues à l'utilisation thérapeutique de l'isotope  $^{131}I$  chez les jeunes femmes ne constituent donc pas un obstacle à cette indication.

## REFERENCES

- (1) J.S. ROBERTSON - D.A. BURMAN gonadal radiation dose and its genetic significance in radioiodine therapy of hyperthyroidism *J. Nucl. Med.* 17 - 828,835, 1977
- (2) H.N. WELLMAN - RT ANGLER : radioiodine dosimetry and the use of radioiodines other than  $^{131}I$  in thyroid diagnosis. *Scandin. Nucl. Med* 1,356 378,1971
- (3) Physicians Desk Reference for Radiology and Nuclear Medicine - Meredith, A.J., 1975 p. 82
- (4) G. JOYET : la teneur initiale à la course de fixation thyroïdienne - *Ann. Radiol.* 7 : 149-178, 1964
- (5) H. JOFFRE - L. FAGES : coefficients d'atténuation et d'absorption massique en énergie. *ILA R.* 3857
- (6) B. PHILIPPON - J. BRIERE : Détermination de la dose absorbée dans un milieu aqueux congelé par  $F_{Li}$ ... communication au 9<sup>e</sup> congrès international de la S.I.R.P. Saclay 23,26 mars 1976
- (7) W.S. SAYDER - M.R. FORD - S.G. WARNER - H.L. FISCHLER *M.I.R.D. pamphlet n° 5*
- (8) W.S. SAYDER - M.R. FORD - G.G. WARNER - S.S. WATSON *M.I.R.D. pamphlet n° 11*
- (9) MARINELLI, L.D. QUIMBY (Jr.) and HINE, G.J. - Dosage determination with radioactive isotopes. II Practical considerations in therapy and protection. *Amer.J. ROENTGEN* 59 : 260. 1948

## EVALUATION OF RADIATION DOSES FROM RADIOACTIVE DRUGS

Jerome A. Halperin and G. Richard Grove  
U. S. Food and Drug Administration  
5600 Fishers Lane  
Rockville, Maryland 20857

I. Regulation of Drugs in the United States.

The Food, Drug, and Cosmetic Act enacted by the U. S. Congress in 1938 established a requirement that new drugs (drugs not generally recognized as safe) be demonstrated to be safe and require an approved New Drug Application (NDA) before they can be shipped in interstate commerce (marketed). In 1962, the Act was amended to require that new drugs be demonstrated to be both safe and effective before a New Drug Application would be approved for marketing. Effectiveness must be demonstrated through adequate and well-controlled investigations, including clinical investigations, conducted by experts qualified to conduct such studies. The 1962 Amendments created a legal instrument called the Notice of Claimed Investigational Exemption for a New Drug, commonly referred to as the IND, in order that the drug could be shipped in interstate commerce for the purpose of conducting the required investigations. The IND has another important purpose--it establishes requirements for protection of human subjects in clinical research from unreasonable and unnecessary risk.

Between 1963 and 1975, radioactive drugs were exempted by FDA from the new drug requirements, i.e., requirements for INDs and NDAs, and were subject to regulations by the U. S. Atomic Energy Commission, now the U. S. Nuclear Regulatory Commission. The exemption was partially terminated in 1971 and was fully terminated in July 1975. All radioactive drugs are now subject to requirements for INDs and NDAs with the exception of (1) certain radioactive drugs for research uses which are generally recognized as safe and effective and which may be used only within prescribed limits of radiation and pharmacological doses and under the purview of Radioactive Drug Research Committees and (2) sealed sources used in brachytherapy and teletherapy which are subject to the Medical Devices Amendments of 1976. These latter categories are outside the scope of this paper.

II. Evaluation of Diagnostic Radioactive Drugs.

There are three major considerations which characterize evaluation of diagnostic radiopharmaceutical drug products (RDP):

1. A RDP usually does not elicit a pharmacologic response, hence evaluation of its safety is primarily related to adequate estimation of the radiation absorbed dose rather than the pharmacologic toxicity.
2. It is considered to be effective if its use results in information leading to a decision as to the presence or absence of disease or abnormality.
3. Its diagnostic value is a function of its biodistribution and the character of its emitted radiation. The nature and extent of change of such distribution by the disease or abnormality is of utmost importance. Thus, investigation should demonstrate both the normal and pathologically altered biodistribution and how the altered distribution is determined in patients.

## A. Preclinical Studies.

Prior to introduction of the radioactive drug into humans, sufficient evidence from preclinical studies conducted in animals must be available to establish reasonable safety. The preclinical studies generally should include biodistribution, pharmacology, toxicology and radiation dosimetry.

It is recognized that only trace chemical quantities of radionuclides are used in most radiopharmaceutical procedures and that for Diagnostic RDPs the absolute amount of the radioactive element is generally well below the levels known to elicit a physiologic or pharmacologic response. Thus, the chemical toxicity of other components of the RDP may be of greater importance than the toxicity of the radionuclide itself. In general, the following preclinical studies are required:

Acute toxicity testing in two animal species to determine the LD<sub>50</sub> of the stable form of the RDP.

Subacute (2-3 weeks) testing in two species, one rodent and one non-rodent, at several dose levels providing adequate margins of safety relative to the equivalent maximum clinical dose.

Chronic toxicity, carcinogenicity, ophthalmic toxicity and reproduction-teratology studies are not generally required for investigation of diagnostic RDPs, however, any or all can be a requirement for any specific radioactive drug, depending upon its chemical constituents, dose, and intended use.

The preclinical studies are required to determine the biodistribution, translocation, and the route and extent of excretion of the RDP. Such information is essential for meaningful dosimetry calculations. Generally, the concentration of the RDP is measured at selected time intervals in all major organs and tissues so that the organ/tissue receiving the highest dose can be identified. Frequently, the organ/tissue receiving the highest dose is not the organ/tissue of primary interest to be imaged, e.g., in bone imaging with <sup>99m</sup>Tc labeled phosphate compounds, the bladder receives a considerably higher dose than the skeleton.

The system of radiation absorbed dose calculations that is used extensively is the one set forth by the Medical Internal Radiation Dose (MIRD) Committee of the Society of Nuclear Medicine. Sponsors of INDs or NDAs are required to submit complete dosimetry information including the equations used with numerical substitutions for all calculations. The calculations must be based upon the highest dose of the radionuclide to be administered and must document all assumptions concerning biodistribution and effective half-lives. Calculations must be shown for the target organ, organ receiving highest absorbed dose, whole body, lens of eye, gonads, active blood-forming organs, and any other organs which may receive significant absorbed doses, e.g., gastrointestinal tract, kidneys, etc. Further, calculations must be shown for trace radiocontaminants including radioactive daughter products.

## B. Clinical Studies.

Clinical studies in humans may proceed when the required preclinical studies have been completed. Initial clinical studies (Phase I) are designed to



demonstrate normal biodistribution, organs receiving maximum concentration of the RDP, biological half-life, routes of excretion, and optimum imaging or sampling tissue. Phase I studies are normally carried out in a small number of normal or diseased patients; the number of normal subjects should be limited to that number necessary to obtain normal biodistribution and metabolic data. Usually children and pregnant or lactating females are excluded although these categories may be studied if it is anticipated that the RDP may be used in these groups.

In determining the optimal dose range for diagnostic RDPs, the radiation absorbed dose should be kept as low as practicable. An adequate number of usable particles or photons should be available to ensure statistically meaningful images or counting results with the instrumentation likely to be employed clinically. Imaging time per view (or sample counting time) must be kept within reasonable limits to prevent image degradation due to patient motion.

While limitations on maximum radiation absorbed doses do not exist, a general working guideline is that if the expected radiation absorbed doses to the whole body and critical organs do not greatly exceed the occupational maximum permissible doses (5 Rem-whole body, 15 Rem-thyroid) and if the sponsor has shown that the proposed doses are not excessive, the studies may be allowed to proceed. In rare instances, such as in the case of  $^{131}\text{I}$ -19-iodocholesterol for adrenal gland scanning, which in females can result in significant doses to the ovaries, the benefit from such a diagnostic procedure must clearly outweigh the potential risk from the radiation exposure and the sponsor of the proposed study must clearly justify the potential superiority of the proposed procedure over existing diagnostic modalities.

Clinical studies in Phases II and III are designed to establish the efficacy of the RDP in controlled clinical trials and its clinical safety in both controlled and ongoing trials. Normals are not used in these phases. Effectiveness is demonstrated by the ability of the RDP to image or otherwise show the presence of disease or abnormality by comparison with radiographic findings, other nuclear medicine procedures or similar RDPs or other clinical procedures.

Radiation dosimetry calculations for Phases II and III studies must include the complete information as described under preclinical studies above, but be based on the human experience obtained in the Phase I clinical trials.

### III. Evaluation of Therapeutic Radioactive Drugs.

A therapeutic radioactive drug product is intended to produce a therapeutic effect through deposition of energy from ionizing radiations in a specific organ or tissue.

#### A. Preclinical Studies.

Preclinical studies of therapeutic RDPs must consider the possible differences in biodistribution of the product between diagnostic (trace quantities) and therapeutic doses of the chemical constituent and must consider the possible pharmacological toxicity of the drug moiety. Evaluation of the radiation toxicity should include the study of two animal species over a sufficient dosage range to allow determination of radiation effects. Long-term

follow-up study may be necessary to properly evaluate radiation effects.

### B. Clinical Studies.

Phase I clinical studies are designed to obtain human biodistribution data utilizing trace quantities of the therapeutic RDP and are normally conducted in normal volunteers and then in patients with the disease for which the drug is intended to determine any differences in biodistribution. Such studies, intended to permit projection of absorbed radiation doses to intended target organs/tissues, critical organs, and other organs expected to receive significant doses, include blood clearance rates, excretion, and organ distribution studies. Evaluation of bone marrow distribution may be particularly important as the radiation dose to the marrow may be the limiting toxicity.

A reasonable starting dose may be the lowest dose expected to produce a therapeutic response. It may be increased until a dose which produces the desired therapeutic toxicity without inducing disabling toxicity is found.

Phases II and III studies must have clearly defined therapeutic end-points by which effectiveness can be evaluated. Compilation of data relating to safety of the RDP continues, with particular reference to radiation toxicity to the organs of primary interest and critical organs, especially bone marrow and gonads.

### IV. Labeling.

Official (approved by FDA) labeling of both diagnostic and therapeutic radioactive drug products includes complete directions to the physician for proper use of the product. Such labeling includes a recommended amount (pharmaceutical dose expressed in  $\mu\text{Ci}$  or  $\text{mCi}$  of activity of the radionuclide component of the RDP) or range for those diagnostic or therapeutic procedures for which the RDP has been shown to be safe and effective.

As with non-radioactive drugs, FDA continues to follow the experience in use of the drug after marketing. If circumstances show that doses originally approved should be changed (increased or decreased) as a result of clinical experience or the introduction of more sophisticated measuring instrumentation, the official labeling may be modified. Similarly, if newer RDPs are introduced which show improvement over existing RDPs in terms of greater diagnostic or therapeutic effectiveness at the same radiation absorbed dose, or equal effectiveness at lesser doses, FDA may initiate action to withdraw approval of the older RDP, or certain indications for that RDP, on the basis of relative safety.

### V. Conclusion.

Radiation absorbed doses from radioactive drug products are thoroughly and carefully evaluated by the Food and Drug Administration in the determination of the safety and effectiveness of the product for its intended uses prior to approval for marketing.

## RISK ESTIMATION OF RADIATION EXPOSURE IN EARLY PREGNANCY

K. Neumeister, S. Wässer

Staatliches Amt für Atomsicherheit und Strahlenschutz  
der DDR und Kinderklinik der Karl-Marx-Universität Leipzig,  
DDR

The biomedical effects of radiation exposure (occupational, by measures in X-ray diagnosis, nuclear medicine or radiotherapy) to low doses in early pregnancy have been the subject of numerous scientific investigations. There are not any uniform ideas as yet on necessary conclusions. In particular discussion is focused on the dose range between 1.5 and 10 R with respect to inducing malformations, functional disorders, carcinomas, increased morbidity rate and genetic damages.

For the GDR, an advisory centre for problems of interruption or non-interruption of pregnancy after radiation exposure in early pregnancy has been established, headed by the author, by the Nuclear Safety and Radiation Protection Board of the GDR, Berlin. Of its work, 56 medical opinions shall be analysed. Out of these, 37 cases relate to the period from 1970 to 1975, before the establishment of this advisory centre. For the medical opinion a detailed anamnesis as to occupation, family and individual case of the married couple was compiled. Special attention was paid to questions about hereditary diseases, malformations in the family, and about noxae which could also induce foetal damage. The dates of conception and foetal radiation exposure were determined as exactly as possible. Finally the foetal dose was calculated or measured by means of a phantom. The results are as follows: In 15 cases (examinations after the 6th week) pregnancy should have been suspected. In almost all cases, the indications for X-ray examination had been made carefully. Possibilities for gonad protection, however, were not always made use of. The individual determination of the foetal dose showed that highly different exposures result from the technique applied in radiography or fluoroscopy and from individual body size (Table 1). In 5 cases pregnancy was interrupted (Table 2). In 2 cases out of these, the interruption was performed on application of patients for fear of radiation damage, despite proper information (foetal dose 0.1 - 1 R). In 3 cases the application was made by ourselves (foetal dose 10.2 - 20 R). In 1 case a pathological-anatomical examination of the foetus was possible. The finding was an underdeveloped foetus without any indications of external or internal malformations (foetal dose in the 16th week = growth period: 10.2 R).

Within a programme of postnatal medical care, 19 children of the cases in Table 1 and at an age of between 10 months and 7 years 1 month could so far be subjected to a single-time thorough check-up. The findings deviating from normal ones are listed in Table 3. The results are as follows: The process of pregnancies was normal. There were all indications

of full development at the time of birth. Deviations from date of birth were within the range of reference. Physical and mental development of all children was normal within the period of investigation. There were no chronic disturbances of health. The haemogram was within normal values. There were no differences between these children and their brothers and sisters. In 37 per cent of cases there was a reduced weight at birth compared with reference values. In the carporadiogram, 37 per cent of children showed a bone development at the lower limit of reference. In 74 per cent of cases there was an increased proneness to infections. 21 per cent of children had malformations (4/19). These findings could be observed also at foetal doses around 1 R in the 1st to 6th week (Table 3). The small number of cases investigated so far makes it seem too early to comment on the question whether these effects are induced by radiation. Nevertheless, the effects observed have - mostly, however, in casuistic communications after higher doses - been described as radiation-induced in literature. For the time being, we wish to make these reservations also in assessing the malformations found. In 3 cases (talipes calcaneus and valgus) the time of irradiation (3rd - 7th week) would be suited to induce such a malformation, but the very small doses should be noted (0.5 - 1 R). In the 4th case (myelomeningocele lumbosacralis), however, there was an exposure to 5 R, but the time (2nd week) does not correspond to the differentiation of organs. All malformations found could be surgically corrected.

From the present findings, we may draw the following conclusions:

- 1) The considerable individual differences of foetal doses in comparable X-ray examinations (Table 1) call for an exact calculation of foetal exposure in each individual case. The establishment of an advisory centre in the GDR has proved a success.
- 2) The findings so far made (Table 2) support our recommendation to advise an interruption at foetal exposures of more than 10 R.
- 3) It is intended to subject all children, if possible, after radiation exposure in utero, to regular examinations over several years to obtain further information (cp. Table 3) on whether it is necessary to change the assumed value of 10 R. (Problems of carcinoma induction, morbidity increase a.o.)
- 4) The rule of X-raying women's abdomina only in the first week after menstruation should be observed more than before.
- 5) In the physicians' training in radiation protection in the GDR, special seminars on problems of radiation exposure in pregnancy have been introduced to improve prophylactic work.

The programme is being continued throughout the GDR.

Tab. 1 Foetal doses at radiation exposures in early pregnancy  
(56 cases / By January 15, 1977)

Type of radiation exposure	Number of examinations <sup>1)</sup>	Foetal dose
Thorax	7	0.1 - 0.2 R
Lumbar spine	9	0.2 - 1.2 R
Pelvis	6	0.2 - 0.5 R
Tract of etomach and intestine	13	0.1 - 18 R (1)
Colon contrastive agent	1	2.5 R
Cholecystogram	13	0.2 - 6 R
I.v. pyelogram	9	1 - 8 R
Pelvis-leg arteriogram	1	1 R
Leg venogram	2	1 R
Aortogram	1	3.5 R
Hysterosalpingogram	3	1.2 - 8.6 R
Isotope nephrogram (J <sup>131</sup> hippurate / Hg <sup>197</sup> neohydrine)	1	1 - 7 R (?)
Telecobalt therapy in case of lymphogranulomatosis	1	20 R
Occupational exposure (X-ray diagnostics)	3	1 R

<sup>1)</sup> in various cases there were combinations of several X-ray examinations

Tab. 3 Findings in children after radiation exposure in utero

Foetal exposure	n	Decreased weight/size at birth <sup>1)</sup>	Caporadio-gram: lower limit of reference	malformations	Increased proneness to infection
1 R	13	4 (0.31)	4 (0.31)	3 (0.23)	10 (0.77)
2 R	2	1 (0.50)	2 (1.0)	-	1 (0.50)
3 R	2	1 (0.50)	-	-	1 (0.50)
5 R	1	1	1	1	1
7 R	1	-	-	-	1
total	19	7 (0.37)	7 (0.37)	4 (0.21)	14 (0.74)

<sup>1)</sup> < 3,000 g / < 49 cm / birth date  $\pm$  10 d around the date calculated  
Decrease by  $\bar{X}$  = 300 g (100 - 600 g)  
Shortening"  $\bar{X}$  = 2 cm

Tab. 2 Medical opinions on radiation exposure in early pregnancy

Name	Age		Anamnesis	Foetal Date	Radiation exposure		Inter- ruption	Special features	Pathological-anatomical findings/ age of foetus at this time
	Female	Male			Type	Dose			
H.P.	27	33	without	2nd	i.v. pyelogram	5 R	no	myelomeningocele lumbosacralis	-
J.L.	27	29	without findings	4th-6th week	cholecysto- gram	1 R	no	talipes calcaneus	-
J.H.	19	18	without findings	8th week	X-ray of stomach	1 R	yes (applica- tion of patient)	-	no examina- tion
C.U.	22	28	without findings	6th week	right ankle joint	0.1 R	yes (applica- tion of patient)	-	no examination
J.W.	16	24	without findings	16th week	thorax, cholecysto- gram i.v. pyelogram	10.2 R	yes	small, slen- der woman	male foetus: 230g, 20.5cm, no internal and external malformations (6th month)= underdeveloped foetus
K.L.	32	36	without findings	7th week	cholecysto- gram, X-ray of stomach	18 R	yes	unfavourable screening conditions	embryotomy / no examination
M.B.	21	23	without findings	1th week	telecobalt therapy at lymphogranu- lomatosis	20 R	yes	-	no examination

## RISK-BENEFIT DISCREPANCIES IN RADIODIAGNOSTIC MEDICINE

ALBERT HALM, F.I.R.  
 Prince of Wales Hospital  
 SYDNEY, 2031. AUSTRALIA

## 1. INTRODUCTION

Ionizing radiation is of immense benefit to mankind, but as a consumer commodity it is often overused and abused in a variety of "justifiable" ways. In the technically advanced countries, like Australia, the maximum annual rate of increase in the number of x-ray examinations may exceed the I.C.R.P. estimates of 15 per cent. I feel that the International Radiation Protection Association should be concerned with these genetic levels which are likely to double the radiobiological effects in human populations. In terms of the risk-benefit valuations, x-ray investigations of clinical significance are invariably justifiable, but the expanding non-productive procedures must not be condoned. You may also find it paradoxical that most modern x-ray apparatus is now capable of enormous reductions in exposures without loss of clinical detail and yet, the genetic doses of the population are increasing.

In this presentation I hope to emphasize: (a) that radiation used in medicine is the only man-made source to which the population of the world is deliberately exposed at this point in time; (b) that the biological risks from present levels of irradiation are not commensurate with the diagnostic benefits achieved; (c) that it is not in the best interest of Radiation Protection to minimize or underestimate the harmful biological effects from low-dose radiation.

## 2. RADIATION RISKS AND DIAGNOSTIC BENEFITS

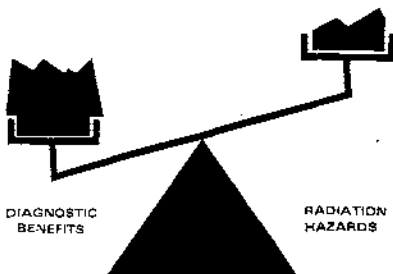

Fig. 1. In justified radiographic investigations the diagnostic benefits far outweigh the radiation risks.

It would be presumptuous of me to dwell on the potential risks from low level radiation; the subject has been well researched and adequately documented by experts. However, I do not agree with the statement that there is no direct evidence of known harmful biological effects to individual human beings or to population groups, at low doses and low dose rates of radiations (IRPA-1975). On the other hand, it must be reiterated that the diagnostic gains derived from legitimate exposures to radiation are so enormous as to make medical practice without radiology unthinkable.

According to the I.C.R.P. (Public.15/16): "Any deliberate exposure to radiation, should be justified by the benefits expected to result from the procedures necessitating the exposure". The implied assumption is that medical practitioners generally, are trained to differentiate between or recognise the value of specific diagnostic x-ray investigations. Unfortunately, medical

curricula in many countries are limited in this respect. However, no restrictions are placed on inexperienced junior medical officers to prevent ill-considered requests for high exposure examinations in our public hospitals. The tendency towards frequent repeat and progress examinations on young, long term patients is hardly justifiable practice. We also endanger future generations by indiscriminately exposing young female patients to radiation without proper regard to their menstrual cycle. The responsibility is firmly on the clinician, the radiologist and the radiographer respectively, but females in early pregnancy are inadvertently irradiated in ever-increasing numbers. The most reprehensible aspect is that many of the investigations are often non-urgent, elective studies which can be delayed to a more appropriate time of the cycle.

The I.C.R.P. standards of radiation protection are determined on the prudent assumption that there is NO threshold level of safety and the biological effects increase linearly with the accumulated dose. However, some of our radiologists contend strongly that there IS a threshold dose below which no biological effects occur - and they tend to ignore the potential cumulative dose. To my knowledge few of our radiologists make an effort to monitor fluoroscopic sessions nor are radiographic exposures recorded routinely for individual dose assessments. Under these circumstances few of us are in a position to state dogmatically that the radiobiological risks are insignificant and the derived diagnostic benefits worthwhile.

### 3. THE MPD AND ITS POTENTIAL EFFECTS

It is now universally recognised that all radiation at whatever level is deleterious and the risk of injury is proportional to dose. However in the early years, after the discovery of x-rays, the lethal effects of radiation were not appreciated and operators suffered the latent consequences.

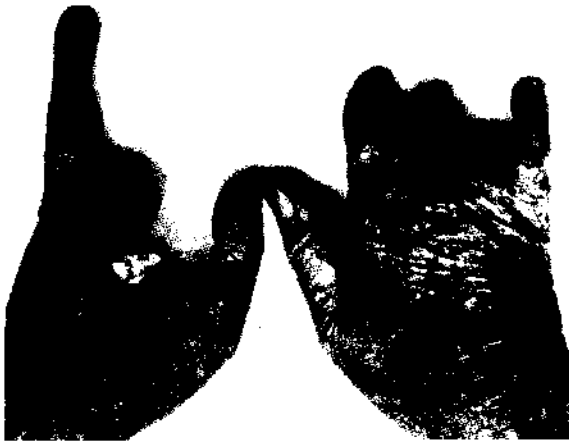

FIG. 2: The ravages of lethal X-radiation preserved for posterity.

Fig.2 shows the remains of the hands which belonged to James N. Young, an Australian pioneer in diagnostic radiography.

Subsequently, the I.C.R.P. set Maximum Permissible Doses for both radiation workers and individuals in the population. However, over the years the MPD was diminished dramatically, Slides Nos. 3 & 4; it is still doubtful if present dose levels provide the safety margin being sought. In any event, the MPD is based on the average biological response of the population to a mean value

of radiation. It is not a dose which takes into consideration radiosensitive individuals within the population. These people are at risk everytime they submit to diagnostic radiation, even if the exposures do not exceed the MPD for the population. It is imperative that we devise a system whereby patients in the high-risk category can be identified prior to complex radiography. The clinician would then be in a position to balance effectively the diagnostic benefits and the radiation risks involved. The MPD is not a criterion of safety as some of us tend to interpret it.



#### 4. TECHNOLOGICAL ADVANCES AND PATIENT DOSE

In most of the developed countries the medical profession has unimpeded accessibility of, and recourse to highly sophisticated x-ray equipment, which is invariably designed to economize on radiation. Perhaps the most characteristic of the new equipment is the caesium-iodide image intensifier with a complex optic system coupled to television monitors. This apparatus is capable of a dose reduction of 90 per cent as compared to conventional fluorography, and it also yields unprecedented dynamic detail. It is therefore not surprising that the image intensifier is used so extensively and for such protracted screening sessions. For sheer simplicity, but more essentially for economic reasons many radiologists throughout the world use fluoroscopy where lower dose radiography would suffice. There is also an increasing tendency on the part of clinicians to request a series of complex, high dose investigations and arrive at a potential diagnosis by the process of elimination. Dr. J. McClenahan, U.S.A., charges that many doctors order "veritable panoramas of x-ray views as a tangible manifestation of their concern

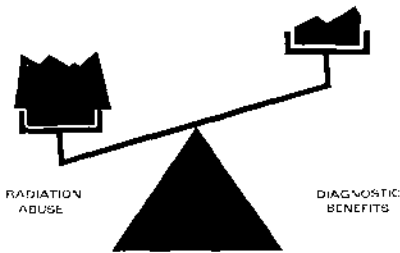

Fig. 3. Panoramic radiography can be more contributive to radiation abuse than diagnostic benefits.

used routinely or competently by the radiographers. A U.S.A. survey in 1970 found that gonad shields were used in only 18 of a sample of 992 male abdominal examinations (1). This may not be a general reflection of neglect to protect patients in our care, but I feel that all disciplines can exert more effort and influence to improve the situation. One fact has emerged, technical perfection is powerless to diminish the patient's dose without our collective concern.

#### 5. PROFESSIONAL JARGON AND STATISTICAL DATA

There seems to exist an inherent reluctance among sections of radiation workers to acknowledge the harmful effects of low level radiation in man. Yet, it has been proven that lethal effects occur in experimental animals, but the evidence is inadmissible in relation to humans. I fail to comprehend why we accept biological, biochemical and behavioural hypotheses based on animal work and practice unreasonable caution where the findings of x-rays are concerned. Many physicists readily declare that "all radiation at whatever level is deleterious to health" and they affirm just as readily that "there is no direct evidence of known harmful effects to humans from low dose irradiation". This is surely an unnecessary contradiction and hardly conducive to effective radiation protection. Would it not be more reasonable to state, "there is no direct evidence that harmful effects do not occur from low dose irradiation", seeing that all radiation is deleterious to health?

It is perhaps regrettable that the experts responsible for radiation safety criteria are so remote from the practical realities of the x-ray department. This impression is gained on every occasion when radiographers attend conferences of this kind and find discussions invariably based on laboratory experiences. Another disheartening feature to anyone concerned with radiation

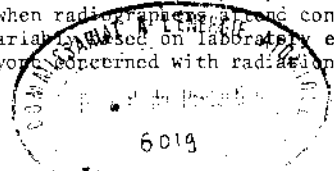

protection is the voluminous statistical information being published on the "surface dose, skin dose, bone marrow dose, gonadal dose, genetically significant dose, population dose, cumulative dose, etc., etc.". The dose calculations for even the simplest examination of a specific area are irreconcilably different. As a radiographer I am frequently intensely embarrassed that I cannot provide reliable information on dosages and yet, I persist in exposing patients to radiation. Knowledgeable patients are becoming concerned about the harmful effects of radiation and medical and paramedical personnel often ignore enquiries or ridicule individuals who question the necessity for radiography.

## 6. SUMMARY AND CONCLUSION

This communication is based on a limited survey conducted among my senior colleagues in major teaching hospitals in Australia and selected centres in New Zealand, England and Germany. To all who participated I express my sincere appreciation. It should be stressed that none of the participants were aware that some of the material will be used in this presentation.

It bears reiteration that a 30-40 per cent reduction in the population dose from medical radiation can be achieved without detracting from existing diagnostic standards. This means that the price for the quality of our radiology in terms of biological hazards, is too excessive. This is a message that can be relayed from this Congress to medical schools and biology classes in high schools throughout the developed countries. Our doctors and patients must develop a greater awareness of the radiation risks from frequent and repetitive examinations. Risk-benefit assessments should certainly be routine practice prior to any deliberate exposure to radiation. At present radiation protection and control is rather lax in Australia, and there is a need to instill in radiology and radiography students an enthusiastic awareness of their responsibilities. The Radiation Safety Officers, who are invariably physicists, also bear a responsibility for the fact that conscious efforts are not being made in x-ray departments to enforce many of the principles contributive to dose reduction. Thought should be given to augment the MPD so that radiosensitive individuals are given more security and protection.

It appears obvious that the accessibility to sophisticated apparatus is likely to increase the population dose from diagnostic radiation and the level is already exceeding that from background sources. This means that radiological exposures are now doubling the biological effects experienced hitherto from natural radiation. The problem of the professional jargon and information used and disseminated by the Association should be resolved. Its pronouncements should be clear and purposeful even to my level of intellect. In conclusion I feel it is important to be concerned with possible radiation hazards of massive proportions at some distant point in time, but low dose radiation is presenting a problem now and it demands our attention.

## BIBLIOGRAPHY

- (1) Health Physics Society News Letter, July, 1975, August, 1973.
- (2) HALL, A., "Radiation Abuse and Its Effects", The Radiographer, June, 1976.
- (3) BIESENDORF, M., "Low-Level Ionizing Radiation and Man", Search-Aug., 1975.
- (4) PAYNE, J. T. & Associates, "A Survey of the Benefits & Risks in the Practice of Radiology", Critical Reviews - Clinical Radiology, Vol.7/Issue 1 1975.
- (5) DELRYMPLE, G. V. & Associates, "Medical Radiation Biology", Saunders U.S.A., 1973.

THE PROBLEMS OF RADIATION SAFETY OF POPULATION AND  
ENVIRONMENTAL PROTECTION RELATIVE TO OPERATION OF  
NUCLEAR POWER STATIONS

D. I. Gusev, N. G. Gusev, A. D. Turkin  
Institute of Biophysics of the Ministry of Public Health  
of the USSR, Moscow

V. D. Turovsky  
Ministry of Public Health of the USSR, Moscow,

Union of the Soviet Socialist Republics

The report presents an estimation of the effect of gaseous-aerosol discharges and liquid effluents from nuclear power stations (NPS) on the radiation situation in the environment. Evaluation and prediction of the population radiation doses are given. Hygienic and ecological aspects of radioactive waste disposal from NPS and discharge of thermal waters into the cooling ponds are considered.

NPS	Type, power MW(e)	Radio- nuclide	Actual releases, Ci / year			Ci/MW (e).year		
			1973	1974	1975	1973	1974	1975
Novo-Voronezhsk NPS	WWR-440x2	IRG	2140	2056	24785	3.83	3.28	43.4
		<sup>131</sup> I	0.026	0.023	0.010	1.2(-4)*	9.4(-6)	4.5(-5)
		<sup>90</sup> Sr	1.0(-4)	1.0(-4)	3.0(-4)	3.0(-5)	5.3(-5)	
		<sup>137</sup> Cs	0.044	0.092	0.153	6.3(-6)	5.1(-6)	2.6(-5)
		<sup>144</sup> Ce	6.0(-4)	1.7(-3)	5.8(-3)	1.1(-6)	2.7(-6)	1.0(-5)
		<sup>60</sup> Co	9.0(-4)	1.9(-4)	4.3(-3)	1.6(-6)	3.0(-7)	7.5(-6)
Kola NPS	WWR-440x2	IRG	300	1050	1530	1.3	3.4	5.1
		<sup>131</sup> I	0	0	1.0(-3)	0	0	3.6(-6)
		<sup>137</sup> Cs	0	0	1.2(-5)	0	0	4.0(-8)
		<sup>110m</sup> Ag	0	0	1.3(-3)	0	0	4.3(-6)

\* 1.2(-4) means  $1.2 \cdot 10^{-4}$

TABLE 1 Gaseous-aerosol releases from Novo-Voronezhsk and Kola NPS (1)

Provision of radiation safety of the population and protection of the environment from radioactive contamination make up an essential part of the programme on nuclear energy development in the USSR. Their problems are being solved by many various research specialists and practical workers of Ministry of Public Health and Ministry of Energetics and Electrification.

The main directions in this field are: improvement in the design of nuclear reactors with the aim of reducing releases of radioactive substances into the atmosphere and cooling ponds; siting NPS at places with favorable natural conditions contributing to reduction of radiation exposure of the population and the environment; regulation of radiation safety standards and sanitary requirements to environmental protection compulsory in designing, building and operating nuclear power stations; improvement of the methods of handling and burial of liquid and solid radioactive wastes providing fulfillment of hygienic and ecological requirements to radiation protection of soil and surface and ground waters; regular dosimetric control of the environment near NPS. In addition wide scientific studies on radionuclide transfer through the environmental media and aquatic and terrestrial biological chains are performed and the models of dispersion of gaseous-aerosol discharges and liquid discharges from NPS are specified in order to improve sanitary regulations, to determine the size of a sanitary-protective zone around NPS, to estimate and predict population radiation doses with due account for future development of nuclear energy. The hygienic and ecological evaluation of thermal discharges from NPS into the water at various regions of the country are made and economical use of thermal waters from NPS is investigated.

As it follows from the experience gained at operating NPS the greatest risk to the population and the environment comes from gaseous-aerosol discharges. The latter contain radionuclides mostly of world-wide distribution with large half-life such as carbon-14, krypton-85, strontium-90, iodine-129, cesium-134 and -137, plutonium-238 and -241, americium-241 and some others. Radionuclides with half-lives of several months and some tens of days belong to the group of mostly regional distribution. In the discharges from NPS radionuclides of this group include the majority of kryptons and xenons, iodine-132 and -136, strontium-89, zirconium-95, niobium-95, ruthenium-103 and -106, argon-40, neptunium-239 and a group of activated products of corrosion: chrome-51, manganese-54, ferrum-59 and cobalt-59 and -60. The group of radionuclides of mostly local distribution includes essentially iodine-131 and relatively short-lived components of the discharges.

Depending on the reactor type and the condition of its active core the summary quantities of the radiative discharges and the ratio of individual radionuclides in them can essentially vary. Table 1 lists actual and normalized aerosol releases from two NPS with aerial water-cooled and water-moderated reactors-440 (WWR-440) for 1973-1975.

Such insignificant releases from NPS provide complete radiation safety of the population and prevent the environment from contamination. Even if the site of Novo-Voronezhsk NPS incorporates other two non-serial reactors whose releases

are more significant than those from WWR-440 contamination of the air and aerosol fallout on the soil at this region do not differ from the corresponding values of the control region. This can be illustrated by Table 2:

Radio-nuclide	Fallout, mCi/km <sup>2</sup> .year			Concentration in the air, 10 <sup>-17</sup> Ci/l		
	2.5 km	4-6 km	50 km	0.5 km	4 km	50 km
141+144Ce	50	53	70	19.3	19.3	18.0
137Cs	16	16	28	7.2	6.2	5.6
90Sr	2.0	1.5	2.4	0.47	0.43	0.33
95Zr+95Nb	0.85	0.77	1.1	0.54	0.42	0.34
103+106Rn	7.5	5.0	12.0	3.7	3.5	2.8
	4.1	3.7	4.7	2.16	1.94	1.92

Distance from the stack: 0.5 km - the site, 4 km - the dwelling place, 50 km - the control point - the city of Voronezh.

TABLE 2 Density of aerosol fallout and their average annual concentrations in the air near N-V NPS (1974)

It is seen from Table 2, that around the N-V NPS both aerosol concentrations in the near-surface air and density of radionuclide fallout (within the measurement error) do not differ from the world-wide fallout levels. At control region of the city fallout density and the concentrations are even somewhat exceed the similar values observed near NPS. It is explained by the precipitation effect of radionuclides on the usual industrial aerosols. The calculated doses to individuals from the population living near NPS do not exceed 2 mrem/year.

Near the Kola NPS concentrations of radionuclide mixture (nearly altogether due to world-wide fallout) do not exceed: in the air -  $4 \cdot 10^{-17}$  Ci/l, in the grass -  $1.1 \cdot 10^{-9}$  Ci/kg of wet weight, in the pine-needle -  $0.9 \cdot 10^{-9}$  Ci/kg of dry weight. The annual radiation doses to the population from discharges of the Kola NPS do not exceed 1 mrem/year.

In the programme of atomic energy development in the USSR much attention is given to the building of large NPS with high-power uranium-graphite reactors (in Russian they are called RBMK-1 000). The Leningrad NPS with two reactors of this type and the Kursk NPS have been put into operation, preoperational work at the Chernobylsk NPS has been nearly completed. The experience gained at operation of the Leningrad NPS shows that discharges from RBMK-1 000 are within the established MPD (maximum permissible discharge's). E. g. in 1974 the summary annual discharge was: of radioactive noble gases - 63 000 Ci, of iodine-131 - 4.8 Ci, of <sup>89</sup>Sr + <sup>90</sup>Sr - 0.14 Ci and of the sum of other long-lived aerosols - 3.3 Ci. The average annual concentration in the air the boundary of the sanitary-protective zone (3 km from the stack) was: for

-radioactive aerosols -  $4.1 \cdot 10^{-17}$  Ci/l; for strontium-90 -  $0.03 \cdot 10^{-17}$  Ci/l and for cesium-137 -  $0.15 \cdot 10^{-17}$  Ci/l. Fallout density of strontium-90 and cesium-137 on the soil at the site of the Leningrad NPS was 2.6 and 0.59 mCi/km<sup>2</sup> respectively, and in the range of 3-10 km from the site - 1.60 and 0.59 mCi/km<sup>2</sup>.year respectively. At the control region (40 km from the site) these values were 1.45 and 0.59 mCi/km<sup>2</sup>.year respectively.

These data make it possible to conclude that the radiation situation at the inhabited regions near NPS operating in the USSR is quite safe. The gaseous-aerosol discharges from the Soviet NPS do not exceed the normal values of discharges from NPS with reactors of the same type (though the utilization factor of nuclear reactors for electricity production at NPS in the USSR is higher than at foreign NPS).

The experience gained at operating NPS allowed the authors (1) to make predicted evaluations of radiation exposure of the population in the USSR to gaseous-aerosol discharges of all NPS, which will be put into operation to 1980. The calculation was made for full nominal reactor power of WWR with 650 MW (e) and RBMK with 10 500 MW (e) (the averaged utilization factor  $k = 0.75$ ).

The physical bases of the model for calculating individual a population doses and calculation equations are given in details in (1). These calculations consider external -irradiation from the cloud, radiation exposure from radionuclides deposited on the soil and internal irradiation from inhaled and digested radionuclides. The calculation results are given in Table 3.

Critical organ	D, mrem/year		D <sub>p</sub> , man-rem/year		
	WWR	RBMK	WWR	RBMK	The sum
The whole body	2.9	3.1	287	1096	1383
Bones	4.0	3.1	520	902	1422
Thyroid (infants younger than 1 year)	8.6	141	447	$1.7 \cdot 10^4$	$1.7 \cdot 10^4$
Lungs	0.003	$6 \cdot 10^{-5}$	0.16	0.005	0.16
Gastrointestinal tract	2.5	0.036	227	10	237

TABLE 3 Predictive evaluations of individual (D) and population (D<sub>p</sub>) doses from gaseous-aerosol discharges of NPS in the USSR in 1980

Individual doses are determined for the population living at the distance of 1.5 km from NPS. Radiation doses for the whole body will be as small as about 3 mrem/year even in these conditions. The main contribution to radiation exposure will co-

me from radionuclides of iodine-131 (digestive intake) and of cesium and strontium. Population doses obtained in these calculations make it possible to estimate the risk of late radiation effects on the population as a result of the use of atomic energy in comparison to unfavourable effects from contamination of the environment due to burning the organic fuel at thermal power stations. These estimations are given by the Soviet authors in ref. (2, 3).

Recently in the USSR much work has been done on developing radiation safety criteria for NPS on the base of collective radiation doses to the population at various distances from NPS. Considering future siting NPS and nuclear thermal stations near large cities and in the densely populated regions the permissible collective doses will be probably taken as important hygienic criterion for restricting irradiation of large population groups (when individual doses are within the established limits). This criterion is also necessary for evaluating the social cost of the detriment caused by radiation accidents.

Development of hygienic requirements and criteria for handling all liquid and solid radioactive wastes produced at NPS is directed at preventing contamination of surface water, ground water soil as well as flora and fauna. In the USSR we use the method of handling all liquid radioactive wastes directly at the site of NPS by evaporating and ion exchange. The wastes in concentrated form are stored in specially designed capacities surrounded by wells for controlling ground water radioactivity. According to the existing plans radioactive wastes of intermediate levels of activity will be solidified by bitumizing and stored in special burial grounds. For this purpose salt content of the wastes, physical and chemical behaviour of radionuclides and the rate of their leaching from bitumized blocks into the water of various kinds were carefully studied.

In the USSR with the view of protecting the environment from radioactive contamination the lower limit of radionuclide concentration in water and solutions classified as "radioactive wastes" has been established (5). All wastes with radionuclide concentration exceeding the permissible concentration (PC) in water specified by "The radiation safety standards (NRB-76)" are considered as liquid radioactive wastes. In this case PC is permissible concentration for the drinking water consumed by population. This requirement of the State Sanitary Surveillance provides protection of the cooling reservoir from contamination by radionuclides since discharge of low-active effluents into them is permitted only if the wastes are not classified as radioactive. The principles and criteria used for controlling sea- and fresh water cooling reservoirs at the site of NPS are given in details in ref. (7, 8).

In contrast to some other countries in the USSR it is not allowed to utilize water which cools turbine condensers at NPS for diluting radioactive wastes to lower their radionuclide concentration at the place of discharge. This practice is based on the statement that unfavourable influence on the flora and fauna of the water reservoir used for discharge of radioactive wastes, on its bottom and littoral is finally determined by the summary radioactivity of discharged radionuc-



rides rather than by their concentration in the discharged water alone. This statement was derived from estimates of the collective radiation doses to the population consuming fish and other industrial products obtained from contaminated waters.

In conclusion it should be noted that the point of view of radiation safety the thermal component of radioactive wastes discharged from NPS into the cooling ponds is of much importance. A great deal of special studies on this problem has been performed on fish and bottom invertebrates in both aquariums and directly in natural conditions with additions of radionuclides into the water (8, 9). It has been established that increase of the water temperature by 5-8° C which occurs near those places where thermal water is discharged from NPS results in the increase of accumulation rate practically of all radionuclides and some chemical elements in the tissues of hydrobionts. It was also observed that non-equilibrium accumulation coefficients of cesium-137, cobalt-60, ferrum-59, chrome-51, antimony-125, phosphorus-32, zinc-65, iodine-131 are increased in fish muscles by 2-5 times. In experiment the accumulation coefficient of mercury-203 trichloride in fish was 15 times more at water temperature +25° C than at +17° C. And it was 5 times more at +17° C than at +3° C. It may result, however, not only from the increase of radionuclide accumulation rate but also from the change of physical and chemical condition of radionuclides under the influence of heat.

A three-fold safety factor with allowance for the heating effect on radionuclide accumulation coefficients in industrial hydrobionts is introduced in the USSR for determining permissible radionuclide contamination levels in the water of cooling ponds. A quota of the radiation dose which makes up 5% of permissible radiation dose to the critical organ in individuals is allotted for the cooling reservoirs.

These strict requirements to the protection of cooling ponds at NPS are brought about by unlimited economical utilization of their water. Amateur and industrial fishing is allowed in them, those are fish-farms at some of them, then water is used for irrigation, etc.

#### REFERENCES

- (1) БУРНАЗЯН А.И. и др. IAEA Rep. 36/351. Austria, Salzburg, 1971.
- (2) САУРОВ М.М. и др. IAEA Rep. 36/347. Austria, Salzburg, 1977.
- (3) ILYIN L.A., KNIZHNIKOV V.A., BARKHUDAROV R.M. A relative risk estimation of excessive frequency of malignant tumors in population due to discharges into the atmosphere from fossil-fuel and nuclear power stations (4th Int. Conf. IRPA Rep. N 410 Paris, 1977).
- (4) ГУСЬЕВ Д.И. и др. IAEA Rep. 36/349-III. Austria, Salzburg, 1977.
- (5) Основные Правила Работы с Радиоактивными Веществами и Другими Источниками Ионизирующих Излучений. N 958-72 (ОСН-72). Москва, Атомиздат, 1973.
- (6) Нормы Радиационной Безопасности (НРБ-76). Москва, "Медицина" (1976).

- (7) ГУСЕВ Д.К. Гигиенические критерии к оценке загрязнения радионуклидами прибрежных морских вод. *Impact of Nuclear Releases into the aquatic Environment*, IAEA, Vienna, (1975) 363-373.
- (8) ГРОМОВ Д.И. и др. "Принципы и критерии гигиенической оценки водосмыв-охлаждителя АЭС". В сб. Тр. научно-технической конференции стран СЭВ по радиационной безопасности АЭС (СССР, Усти-над-Лабем, 1975). Прага (1976).
- (9) ГРОЧЕВ М.К. "Влияние температуры воды на накопление, распределение и выведение кобальта-60 у рыб". В сб. Тезисы докладов Всесоюз. конф. по радиэкологии. Москва (1977).

## LIMITATION OF RADIOACTIVE EMISSIONS FROM REPROCESSING PLANTS

H. Monka\*, H. Edelhäuser\*\*, D. Hesel\*, P. Schmidtlein\*,  
G. Schwarz\*, O. Wagner\*

\* Professorial Chair for Reactor Technology  
Rheinisch-Westfälische Technische Hochschule, Aachen

\*\* Federal Ministry of the Interior, Bonn

## 1. INTRODUCTION

Nowadays in nuclear power plants of modern design the emission rates can, with justifiable expenditure, be kept sufficiently low. Tab. 1 shows the emission rates to the atmosphere expected in the vicinity of a nuclear power plant with a light water reactor in the Federal Republic of Germany and the resulting radiation exposure in the maximum of the concentration. The emission rates from nuclear power plants are kept low essentially by leak-proof fuel - elements. In reprocessing plants this barrier has to be destroyed, so the only way to keep the emissions low is by retention facilities.

## 2. RADIATION EXPOSURE IN THE VICINITY OF REPROCESSING PLANTS

Tab. 2 shows the release rates of a reprocessing plant for 4 different cases with different retention factors. Case 1 corresponds to values for plants built till this date (1), while case 2 shows the release rates which at the moment are being discussed with reference to the first large reprocessing plant in the Federal Republic of Germany (2). Cases 3 and 4 show values for an ever higher retention than in case 2. The doses resulting from the releases as shown in Tab. 2 are summarized for all four cases in tabs. 3 and 4. While in case 1 the limits given by the German Radiation Protection Decree from Oct. 1976 (3) for the total body (30 mrem/a) and for the thyroid, (90 mrem/a) are almost reached or even exceeded respectively, the values given in case 2 are well within the limits. Cases 3 and 4 mean another step towards the demand of the radiation protection decree, to keep the doses as low as feasible.

## 3. COLLECTIVE DOSES DUE TO EMISSIONS FROM REPROCESSING PLANTS

The dose limits existing up to now take care of the limitation of individual doses. Nowadays attempts are made to evaluate the effects of the emissions on large population groups by collective doses. The collective doses caused by the emissions specified in case 2 are summarized in tab. 5 for different nuclides and affected areas (regional and global). The high contribution of C 14 to the total body dose and of Kr 85 to the skin dose, is especially noticeable. The collective doses are, as seen in fig. 2, essentially influenced by the period of intergration.

In order to introduce the collective doses as another criterion for

the limitation of radioactive emissions, it is necessary to make an evaluation of the resulting detriment. According to a principle used in many areas of environmental protection in the Federal Republic of Germany, all subsequent detriments have to be paid for by the person or institution that causes them. It is therefore necessary to relate a monetary value to the radiation detriment in order to have a basis for comparison with the expenditure for the retention facilities, (4). Rough estimations for that are given in (5) and (6). According to these estimations a reduction of the emissions from case 1 to case 3 as shown in Tab. 2 seems to be suitable.

#### 4. FUTURE RADIATION EXPOSURE DUE TO GLOBALLY DISTRIBUTED RADIONUCLIDES

Due to the worldwide extension of nuclear energy and a consequently increasing emission, an increase of the doses from globally distributed radionuclides is caused. Figs. 3, 4 and 5 (7) show the expected doses from some globally distributed radionuclides. The doses due to C 14 and Kr 85, if they are not retained, will hardly be accepted by the population. The release of C 14 is mainly due to the reprocessing of high temperature reactor fuel-elements (8).

#### 5. SUMMARY

The demand for retention of radionuclides in reprocessing plants exceeding the assumptions made in case 1 may now be concluded either from the individual- or from the collective doses. With regard to radiation protection it would seem sensible to retain 90% of H 3, 80% of C 14, 90% of Kr 85, and 99,5% of Iodine in reprocessing plants, while the emission rate of the aerosoles should be less than  $3 \cdot 10^{-6}$ . In the Federal Republic of Germany the first steps have now been taken with the limitation of the Kr 85 emission from a single plant to  $10^6$  Ci/a (2).

#### REFERENCES

- (1) Oak Ridge National Laboratory (1970) ORNL-4451
- (2) Empfehlungen der SSK, Bundesanzeiger Jahrgang 27, No. 132, July 1975
- (3) Strahlenschutzverordnung, Bundesgesetzblatt Z 1997 A, S. 125, 1976
- (4) International Commission on Radiological Protection, Publication 22
- (5) Lindell, B. (1976) Health Physics, Vol. 31, pp. 265 - 272
- (6) USNRC Federal Register, vol. 40, No. 137, May 3, 1975
- (7) Bonka, H. et al. (1975), JJI 1220
- (8) Bonka, H. et al. (1973), Kerntechnik, No. 7

Nucleide	Exposure pathway	Design water reactor				Pressurized water reactor			
		Intake	Body burden	Skirt	Bone	Intake	Body burden	Skirt	Bone
H3	Inh	3E-4	3E-4	3E-4	3E-4	3E-4	3E-4	3E-4	3E-4
C14	Inh	1E-4	1E-4	1E-4	1E-4	1E-4	1E-4	1E-4	1E-4
K85	Inh	1E-4	1E-4	1E-4	1E-4	1E-4	1E-4	1E-4	1E-4
Sr89	Inh	1E-4	1E-4	1E-4	1E-4	1E-4	1E-4	1E-4	1E-4
Sr90	Inh	1E-4	1E-4	1E-4	1E-4	1E-4	1E-4	1E-4	1E-4
I131	Inh	1E-4	1E-4	1E-4	1E-4	1E-4	1E-4	1E-4	1E-4
Cs134	Inh	1E-4	1E-4	1E-4	1E-4	1E-4	1E-4	1E-4	1E-4
Cs137	Inh	1E-4	1E-4	1E-4	1E-4	1E-4	1E-4	1E-4	1E-4
Pu238	Inh	1E-4	1E-4	1E-4	1E-4	1E-4	1E-4	1E-4	1E-4
Pu239	Inh	1E-4	1E-4	1E-4	1E-4	1E-4	1E-4	1E-4	1E-4
Am241	Inh	1E-4	1E-4	1E-4	1E-4	1E-4	1E-4	1E-4	1E-4
Am242	Inh	1E-4	1E-4	1E-4	1E-4	1E-4	1E-4	1E-4	1E-4
Cm244	Inh	1E-4	1E-4	1E-4	1E-4	1E-4	1E-4	1E-4	1E-4
Total									

Tab. 1. Radiation exposure due to airborne releases at the maximum of the concentration of the ground level around light water reactors in West design (1000 MWt) in the Federal Republic of Germany (2 x 3 km<sup>2</sup> area) of an emission height of 200 m; 100% CO<sub>2</sub>.

Nucleide	Activity in repository (Bq)	Case			
		Case 1	Case 2	Case 3	Case 4
H3	7 E 5	7 E 5	10 E 4	17 E 4	100 E 3
C14	500	1500	1500	1500	100 E 3
K85	12 E 7	12 E 7	12 E 7	12 E 7	100 E 3
Sr89	1 E 7	1 E 7	1 E 7	1 E 7	1 E 90 E 7
Sr90	100 E 4	100 E 4	100 E 4	100 E 4	1000 E 0 E 4
I131	32	100 E 0 E 2	700 E 1 E 6	200 E 1 E 6	1000 E 0 E 2
Cs134	5 E 8	5 E 8	3 E 8 E 4	3 E 8 E 4	5 E 8 E 5
Cs137	1 E 8	1 E 8	3 E 8 E 3	3 E 8 E 3	1 E 90 E 1
Pu238	1 E 6	1 E 6	1 E 6	1 E 6	1 E 6
Pu239	1 E 5	1 E 5	1 E 5	1 E 5	1 E 5
Am241	1 E 5	1 E 5	1 E 5	1 E 5	1 E 5
Am242	1 E 5	1 E 5	1 E 5	1 E 5	1 E 5
Cm244	1 E 5	1 E 5	1 E 5	1 E 5	1 E 5

Tab. 2. Activity come to a reprocessing plant for LWR-fuel elements and emission rates for airborne releases at different retention factors (RF): Capacity 1500 t/a, cooling time of fuel elements 200 d.

Nucleide	Exposure pathway	Case				Case 2			
		Intake	Body burden	Skirt	Bone	Intake	Body burden	Skirt	Bone
H3	Inh	4.2	4.2	4.2	4.2	4.2	4.2	4.2	4.2
C14	Inh	0.93	0.93	0.93	0.93	0.93	0.93	0.93	0.93
K85	Inh	0.41	0.41	0.41	0.41	0.41	0.41	0.41	0.41
Sr89	Inh	0.01	0.01	0.01	0.01	0.01	0.01	0.01	0.01
Sr90	Inh	0.01	0.01	0.01	0.01	0.01	0.01	0.01	0.01
I131	Inh	0.01	0.01	0.01	0.01	0.01	0.01	0.01	0.01
Cs134	Inh	0.01	0.01	0.01	0.01	0.01	0.01	0.01	0.01
Cs137	Inh	0.01	0.01	0.01	0.01	0.01	0.01	0.01	0.01
Pu238	Inh	0.01	0.01	0.01	0.01	0.01	0.01	0.01	0.01
Pu239	Inh	0.01	0.01	0.01	0.01	0.01	0.01	0.01	0.01
Am241	Inh	0.01	0.01	0.01	0.01	0.01	0.01	0.01	0.01
Am242	Inh	0.01	0.01	0.01	0.01	0.01	0.01	0.01	0.01
Cm244	Inh	0.01	0.01	0.01	0.01	0.01	0.01	0.01	0.01
Total									

Tab. 3. Rad of an exposure due to airborne releases of the maximum of the concentration of ground level of a reprocessing plant with different retention factors (RF = 10<sup>-3</sup>) of an emission height of 200 m.

Nucleide	Exposure pathway	Case				Case 2			
		Intake	Body burden	Skirt	Bone	Intake	Body burden	Skirt	Bone
H3	Inh	4.2	4.2	4.2	4.2	4.2	4.2	4.2	4.2
C14	Inh	0.93	0.93	0.93	0.93	0.93	0.93	0.93	0.93
K85	Inh	0.41	0.41	0.41	0.41	0.41	0.41	0.41	0.41
Sr89	Inh	0.01	0.01	0.01	0.01	0.01	0.01	0.01	0.01
Sr90	Inh	0.01	0.01	0.01	0.01	0.01	0.01	0.01	0.01
I131	Inh	0.01	0.01	0.01	0.01	0.01	0.01	0.01	0.01
Cs134	Inh	0.01	0.01	0.01	0.01	0.01	0.01	0.01	0.01
Cs137	Inh	0.01	0.01	0.01	0.01	0.01	0.01	0.01	0.01
Pu238	Inh	0.01	0.01	0.01	0.01	0.01	0.01	0.01	0.01
Pu239	Inh	0.01	0.01	0.01	0.01	0.01	0.01	0.01	0.01
Am241	Inh	0.01	0.01	0.01	0.01	0.01	0.01	0.01	0.01
Am242	Inh	0.01	0.01	0.01	0.01	0.01	0.01	0.01	0.01
Cm244	Inh	0.01	0.01	0.01	0.01	0.01	0.01	0.01	0.01
Total									

Tab. 4. Radiation exposure due to airborne releases of the maximum of the concentration of ground level of a reprocessing plant with different retention factors (RF = 10<sup>-3</sup>) of an emission height of 200 m.

Nucleide	Emission (Ci)	Area (km <sup>2</sup> )	Total dose (mSv/a)		Collective dose (man·mSv/a)		Dose (mSv/a)
			World	FRG	World	FRG	
H3	7 FA	12	7	7	7	7	7
C14	500	70	500	500	500	500	500
K85	12 E 7	12	12	12	12	12	12
I131	32	70	32	32	32	32	32
Cs134	5 E 8	70	5 E 8	5 E 8	5 E 8	5 E 8	5 E 8
Cs137	1 E 8	70	1 E 8	1 E 8	1 E 8	1 E 8	1 E 8
Pu238	1 E 6	70	1 E 6	1 E 6	1 E 6	1 E 6	1 E 6
Pu239	1 E 5	70	1 E 5	1 E 5	1 E 5	1 E 5	1 E 5
Am241	1 E 5	70	1 E 5	1 E 5	1 E 5	1 E 5	1 E 5
Am242	1 E 5	70	1 E 5	1 E 5	1 E 5	1 E 5	1 E 5
Cm244	1 E 5	70	1 E 5	1 E 5	1 E 5	1 E 5	1 E 5
Total							

Tab. 5. Collective doses by an emission over the rest of a reprocessing plant due to case 2 as stated in table 2.

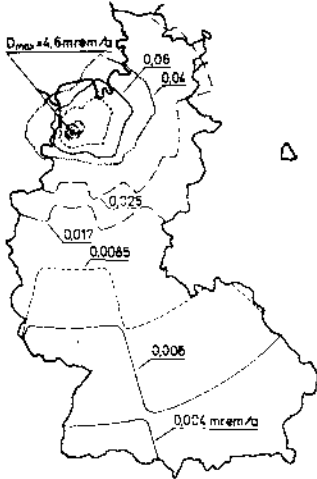

Fig. 1: Radiation exposure of the skin due to Kr 85 released from a reprocessing plant in the northern part of Germany,  $E_{Kr85} = 1.2E8$  Ci/a (Assumption: Radionuclides remain in dispersion sector)

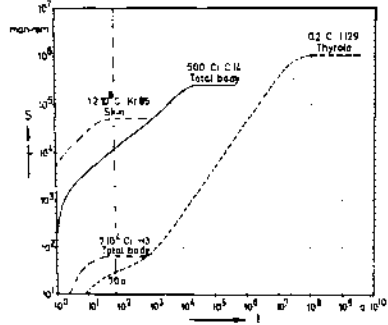

Fig. 2: Cumulative doses by a release over one year of  $^{137}Cs$ ,  $^{125}I$ ,  $^{137}Cs$  and  $^{129}I$  for case 2 as listed in table 2 in dependence of integration time (World population  $10^9$ )

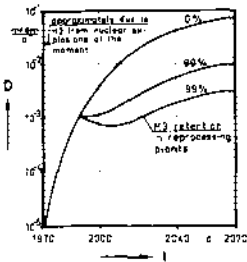

Fig. 3: Expected radiation exposure of the total body in the northern hemisphere due to globally distributed  $^{137}Cs$  from nuclear power plants and reprocessing plants

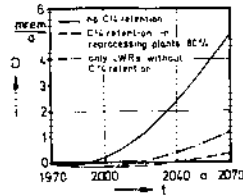

Fig. 4: Expected radiation exposure of the total body in the northern hemisphere due to globally distributed  $^{14}C$  from nuclear power plants and reprocessing plants (including future increase of  $CO_2$  concentration)

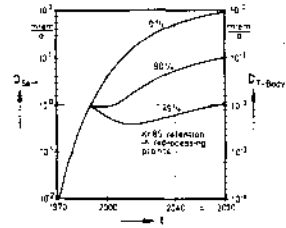

Fig. 5: Expected radiation exposure of the sun and the total body in the northern hemisphere due to globally distributed  $^{137}Cs$  from nuclear power plants and reprocessing plants

## IMPLICATIONS OF COLLECTIVE DOSE EVALUATION TO LIMITING REACTOR RELEASES

R. H. Clarke

Central Electricity Generating Board, Berkeley Nuclear Laboratories,  
Berkeley, Gloucestershire, UK.

## ABSTRACT

The currently accepted criterion of a given annual dose at the site boundary is used to set atmospheric release levels from a notional reactor and the associated collective doses are compared for this reactor at sites with differing real population distributions. It is concluded that while the dose to the most exposed individual must be at an acceptable level, the reactor design should have an operational radioactive release rate set also by taking account of the collective dose over a limited dose or distance range.

## 1. INTRODUCTION

Although the ICRP has suggested dose limits both for the most exposed individual members of the public and for the population as a whole (1,2), up to the present time the criteria for the release of radioactive effluents from nuclear installations have been set almost entirely by considerations of the potential doses received by the most highly exposed individuals. These individuals are taken to be at the point of closest approach to, or distance of maximum effluent concentration from, a nuclear site. ICRP has now suggested (3) the use of new concepts in support of its "as low as readily achievable" recommendation. These new concepts involve the estimation of the total detriment to the population which at present, because of the assumption of a linear dose-response relationship, is proportional to the collective dose.

In this paper the currently accepted criterion of a given dose at the site boundary has been used to determine annual atmospheric release levels from a notional reactor design. The resulting collective doses are compared between existing UK nuclear sites which have differing population distributions, and as a function of the reactor design variables, stack height and distance to the site boundary.

## 2. METHODS OF CALCULATION

The notional reactor used for these calculations was assumed to be operating with defective fuel cladding so that noble gases are continuously discharged to atmosphere through a stack following a delay period of several hours during which radioactive decay is assumed to occur. The annual whole body cloud- $\gamma$  doses which result as a function of distance from the reactor were computed using the WERLIE code (4). The mean frequencies of occurrence of the various Pasquill atmospheric stability categories were taken, together with data for the mean windspeeds around typical CEB coastal sites, from Meteorological Office data (5).

Having obtained the spatial distribution of individual doses, in order to estimate collective doses, a population density distribution is required for each site under consideration. The population distribution over the whole of the UK has been established in matrix form for collective dose calculations based upon the 1971 UK Census data which is available in geocoded

format for wards and civil parishes. For this work a population density matrix has been set up with a spatial resolution of 1.5 km, which is adequate for collective dose calculations. In Fig. 1 the population density matrix has been used to give the cumulative population as a function of distance from the five representative existing CEB nuclear sites chosen for this study.

### 3. ILLUSTRATIVE EXAMPLES OF COLLECTIVE DOSES

In Fig. 2 the annual whole body collective dose is given as a function of distance from each of the five sites considered. At each site the notional reactor is assumed to be discharging noble gases continuously from a 50 m stack and the collective doses are presented per unit of exposure (mrad) received by the most exposed individual at the site boundary, which is taken to be 400 m from the stack. It is seen from Fig. 2 that the collective dose characteristics of current UK nuclear sites vary considerably, both in the absolute values of total collective dose and in the rate of accumulation of collective dose. At the Hartlepool site, the collective dose within 10 km is half of the total accumulated over the whole country while at Wylfa half the total collective dose is accumulated beyond 100 km from the site. In general the lower collective doses are from the more remote sites and the collective doses do tend to finite limits partly because of radioactive decay of the noble gases. However other calculations have shown that similar results can be obtained for long-lived activity and in such cases the more remote sites accumulate a larger contribution to collective dose from distances beyond 100 km.

In Fig. 3 the total collective doses of Fig. 2 are presented as a function of the individual doses received, arranged in ascending order of contribution to the total collective dose. At Hartlepool, the largest contribution to collective dose comes from a population group receiving doses up to 10% of the dose received at the site boundary, whereas at Dungeness the majority of the collective dose is integrated over individuals receiving doses of less than 0.02% of the site boundary dose. Thus it is seen that not only are the collective doses very different between sites for the same release, but the number of individuals exposed to a given dose rate varies more widely. In Figs. 4 and 5 annual collective dose profiles are produced for Hartlepool and Dungeness which demonstrate the different spatial distribution of contributions to collective dose; the surfaces are normalised so that they each have the same vertical height for the population cell receiving the highest collective dose and the scaling factor is 8.3 times greater for the Dungeness surface than that for Hartlepool.

Finally in Fig. 6, the results of collective dose calculations are presented as a function of the height of release and distance to the site boundary when the release rate is set so as to keep the dose constant at the site boundary. This demonstrates the major defect in the concept of limiting reactor releases solely on consideration of the dose received by the critical group, in that the collective dose can vary by two orders of magnitude for different sites, stack heights or site boundary distances and these collective doses may be accumulated at dose rates which are not insignificant compared with that received by the most exposed individual.

### 4. CONCLUSIONS

For the same reactor release, but at sites with differing population distributions, it has been shown that there are significant differences both in the collective doses and in the number of individuals receiving doses in any given dose range. If the criterion for setting reactor releases is the



dose received by the most exposed individual, then the designer has freedom to increase both stack height and distance to the site boundary, in order to meet the criterion. This can increase both the collective dose and the number of individuals exposed to doses lower than, but near, the dose limit. While it is accepted that the most exposed individual must not be subjected to undue risk, a collective dose assessment for a given site is a useful indication of its radiological impact. If a collective dose limit were to be incorporated into safety criteria, it would appear that sites with large close-in populations would have more restrictive release limits than sites with low population densities over wide areas.

5. REFERENCES

- (1) ICRP2, Report of Committee II, para. 53-71 on "Permissible Dose for Internal Radiation", Publication 2, Pergamon Press (1959).
- (2) ICRP9, para. 70-85 of Recommendations of the ICRP, Publication 9, Pergamon Press (1966).
- (3) ICRP22, "Implications of the Commission Recommendations that Doses be kept as low as readily achievable", Publication 22, Pergamon Press, (1973).
- (4) Clarke, R.H., "The WEERIE program for assessing the radiological consequences of airborne effluents from Nuclear Installations", Health Physics, 25, 267-280 (1973).
- (5) Smith, F.B., "A Pasquill Stability Map of the UK", Unpublished Meteorological Office results (1976).

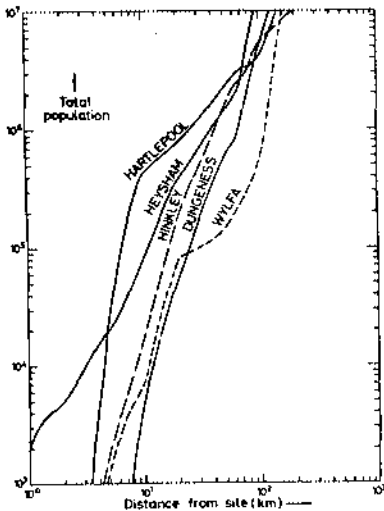

FIG.1 Cumulative Population Around Existing CEBG Nuclear Sites.

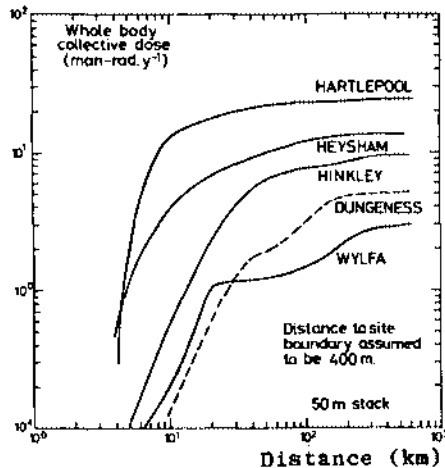

FIG.2 Whole Body Collective Dose per Year per mrad per Year at the Site Boundary for a Continuous Release of Mixed Noble Gases

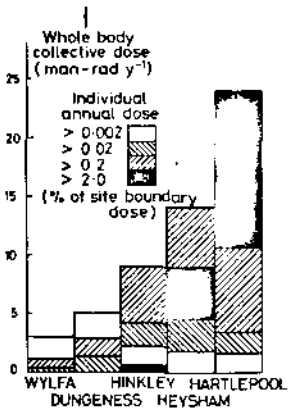

FIG. 3 Whole Body Collective Dose per Year per mrad per Year at the Site Boundary, Ranked in Order of Contribution from Individual Doses Received

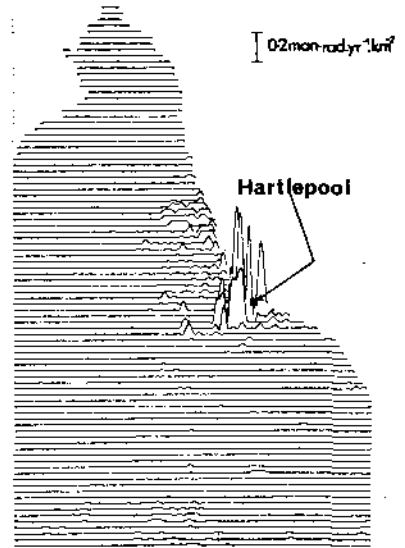

FIG. 4 Collective Dose profile around Hartlepool Site in NE England per mrad.y<sup>-1</sup> at the site boundary.

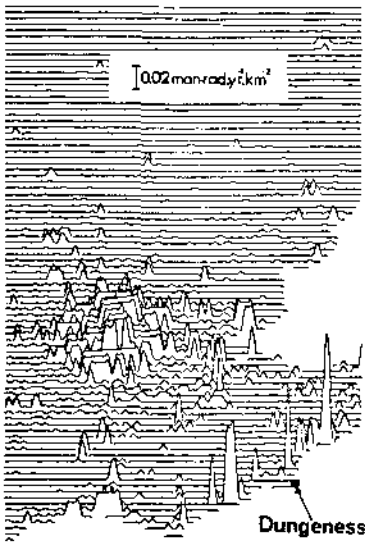

FIG. 5 Collective Dose profile around Dungeness site in SE England for the same release as used in Fig. 4.

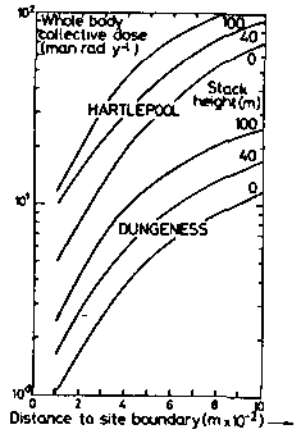

FIG. 6 Whole Body Collective Dose per Year per mrad per Year at the Site Boundary as a Function of that Distance and Height of Release for Noble Gases.

CONCEPTS FOR THE CALCULATION OF RADIATION EXPOSURE IN THE  
ENVIRONMENT OF NUCLEAR PLANTS FOR PLANNING AND SURVEILLANCE PURPOSES

H.D. Brenk, K.J. Vogt

Jülich Nuclear Research Centre, Central Department for  
Health Physics

and

K. Brüssermann, G. Schwarz

Chair for Reactor Technology of the RWTH Aachen  
(Aachen Institute of Technology)

## 1. INTRODUCTION

In connection with the release of radioactive substances from nuclear plants, the following requirements are to be met in respect of the assessment of radiation exposure of persons in the environment of the plant:

- For the purpose of planning and licencing of nuclear plants, the release rates of radioactive substances are to be limited to such a degree that the dose limit values specified in radiation protection regulations are not exceeded on any site. In doing so, account must be taken of pre-exposure and migration of radionuclides in the environment. This requirement involves the calculation of environmental maximum annual doses (EMAD) for individuals.
- During the operation of nuclear plants it is necessary to calculate the radiation exposure resulting from the annual releases measured for the year of reference. This application requires the calculation of environmental dose commitments (EDC) on the basis of annual releases for persons living in the vicinity of the plant.
- In connection with the long-term prediction of the environmental impact caused by the entire nuclear industry, problems will also arise in conjunction with the local and regional development of the nuclear power industry.

## 2. CALCULATION OF RADIATION EXPOSURE USING THE EXAMPLE OF INGESTION

### 2.1 Description of the Transfer of Nuclides in Food Chains by Means of Multi-Compartment Models

The calculation of the ingestion dose involved in the consumption of contaminated terrestrial food is based on the compartment model shown in fig. 1.

Sources /comp. 7/ of the environmental contamination under consideration are fallout and washout in connection with releases of waste air or sprinkler irrigation in connection with the discharge of activity into bodies of water. This may result in a radiation exposure of man by the transfer of nuclides into the food chain.

This transfer is divided into two main pathways. The first one begins with the direct deposition on soil vegetation /1/ and reaches man either directly via vegetables etc. or indirectly via animal products such as milk, meat, etc. /2/. The other pathway essentially involves the transfer from the ground surface /4/ into the soil /5/ and from there through the uptake by

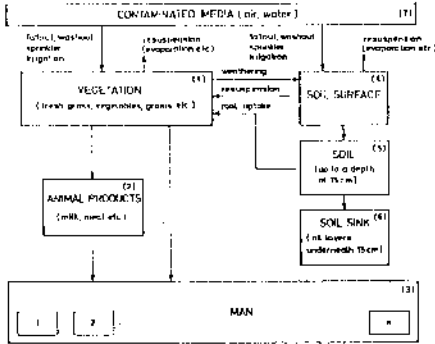

Fig. 1  
Radiation exposure model by ingestion of radioactively contaminated food

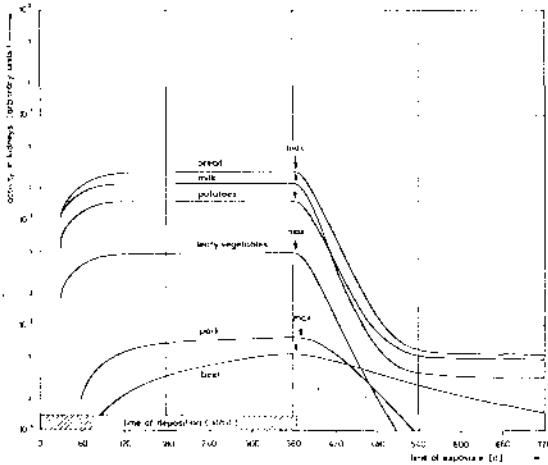

Fig. 2  
Sr 90 activity of the kidneys due to ingestion of contaminated food as a function of exposure time for a contamination period of 12 months (The biological half-life of Sr in the kidneys is 16 days)

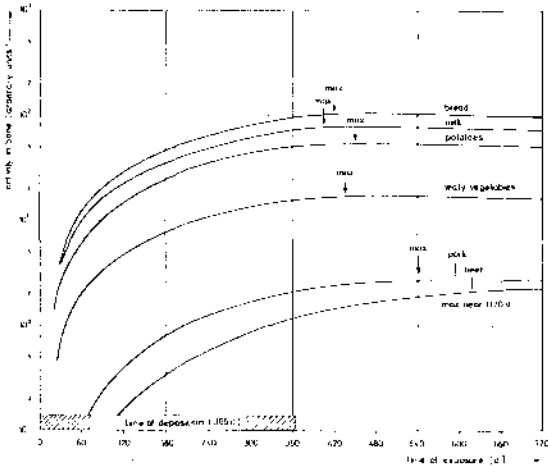

Fig. 3  
Sr 90 activity in the bone due to ingestion of contaminated food as a function of exposure time for a contamination period of 12 months (The biological half-life of Sr in bone is  $1.8 \times 10^4$  days)

roots into plants /1/, from where the nuclides may likewise get into the food chain. Since part of the radionuclides involved (e.g. Sr 90, Cs 137) stay in the upper soil layer /5/ for rather long periods of time, there will be an accumulation in this layer, leading to a long-term contamination of the food chain, which may be effective far beyond the lifetime of individual installations.

For describing the activity transfer in the environment according to fig.1, the first approximation is based on a system of linear differential equations of first order (1), (2).

The solution of this system of equations is illustrated in fig. 2 and 3, where the time-dependent activity courses of Sr 90 in the kidneys and the bone due to ingestion via various kinds of food pathways are plotted, assuming constant deposition on the upper soil layer and on vegetation for a period of twelve months.

The basic difference between fig. 2 and fig. 3 is the different residence time of Sr 90 in the organ affected. Due to the rapid removal in the kidneys, the activity inventory chiefly follows the contamination by direct deposition. It is superimposed by the activity supply through the roots. As a rule, the curves reach their maximum at the end of the contamination period.

The activity course in the bone gives a quite different picture. Due to the long biological half-life of Sr 90 in the bone, the organ activity for all food pathways follows the environmental contamination with considerably greater delay. None of the maximum values is reached before the end of the deposition period.

The activity inventory then remains almost constant because the removal from the organ takes place at an extremely slow rate.

## 2.2 Calculation of Doses

### 2.2.1 Correlation between Dose Commitment and Maximum Annual Dose

The individual organ doses can be calculated with the aid of the time-dependent activity courses in the organs affected.

Investigations have shown that the identity of the dose commitment and the maximum annual dose, as stated by LINDELL (3), is also applicable in the present case of ingestion of radionuclides with due regard to possible accumulation effects in the soil. Consequently, this identity does not only apply to the transfer of nuclides in the human organism (resulting in internal doses), but is also applicable when including nuclide migration in the environment on the assumption that the transfer of nuclides is independent of the level of activity and that all effects of second order are negligible. This means: EMAD = EDC. In all other respects, the conditions according to (3) are applicable.

### 2.2.2 Dose Conversion Factors

As explained in more detail in another context (1), (2), it is of advantage for practical application to define the ingestion dose in the following form

$$D = g \cdot N \cdot S \cdot Q$$

g ingestion dose conversion factor in rem/Ci

N ingestion utilization factor in  $\pi^2$

S sedimentation factor, e.g. fallout factor in  $\pi^{-2}$

Q annual amount of release in Ci

The individual factors can be calculated according to (1) and (2), where the values in question are already listed for a number of nuclides, organs and types of food pathways.

The ingestion dose conversion factor ( $g$ ) in rem per orally ingested amount of activity in Ci exclusively describes the transfer and distribution in the human organism, whereas the ingestion utilization factor ( $N$ ) represents a measure for the transfer of nuclides in the biosphere from contaminated soil up to the oral activity ingestion with food. For illustration purposes, this factor may be interpreted as the effective area, which is the origin of the volume of activity ingested with food and is essentially dependent on the transfer data of the respective food pathway. Furthermore, the two factors  $g$  and  $N$  also depend on the age of the person exposed, on the duration of exposure or utilization and on the release time of the installation. The product  $S \cdot Q$  specifies the annual mean of surface contamination in Ci/m<sup>2</sup>.

### 3. CONCLUSIONS

Owing to the identity of environmental dose commitment (EDC) and environmental maximum annual dose (EMAD), both problems (licensing of new installations or routine inspection of a plant already in operation) can be handled according to the same computer model for calculating radiation exposure, i.e. it is of no consequence whether the concept of maximum annual dose or the concept of dose commitment is applied. The values specified in (1) and (2) have been determined for the calculation of environmental dose commitment.

Prediction calculations to determine the radiation exposure of individual persons caused by the entire nuclear industry must be based on maximum annual doses.

On the assumption of a certain status of expansion in nuclear industry being frozen during the prediction period for the time of average human life expectancy, it will be possible to calculate a person's radiation exposure at the end of his life using the maximum annual dose. This offers a criterion for assessing whether or not the momentary status of nuclear industry will still be acceptable for individual persons at the end of their lives.

For practical calculation purposes this means: Even in this case, the calculation of dose commitments may be based on dose conversion factors in the same way as in connection with the two problems discussed before.

The doses calculated in this manner are sufficiently conservative.

### REFERENCES

- (1) BRENN, H.D., Ein anwendungsbezogenes Konzept zur Berechnung der Umweltbelastung durch Abluftemissionen kerntechnischer Anlagen für Standorte in der Bundesrepublik Deutschland (Will be published)
- (2) BRENN, H.D., VOGT, K.J., Dosisfaktoren zur Berechnung der Strahlenexposition durch radioaktive Abluft kerntechnischer Anlagen Jül 1381, Jan. 77
- (3) LINDELL, B., Assessment of Population Exposures, IAEA-SM-172/B, Aix-en Provence 1973

Estimated radiological effects of the normal discharge of radioactivity from nuclear power plants in The Netherlands with a total capacity of 3500 MWe

G. van der Lugt, H. Wijker, N.V. KERMA, Arnhem, The Netherlands

## 1. Introduction

In the last few years there has been much discussion in The Netherlands about the installation of three nuclear power stations which, together with the two existing plants, would total up capacity to 3500 MWe.

To get an impression of the risk involved for the population from such a program the SEP (Co-operative Electricity Generating Companies) was asked by the government to make a risk analysis of the entire fuel cycle. This risk analysis was completed in 1975 (1).

Part of the analysis consisted in an estimation of the radiological effects due to the normal discharge of radioactivity from the power plants.

Calculations were carried out for the two existing plants (a 54 MWe BWR and a 470 MWe PWR) and for 1000 MWe PWR's and BWR's on four additional potential sites. These sites were chosen in such a way that consideration of other possible sites in the country should give no divergent information.

In this paper the underlying principles and some of the results of this partial risk analysis are given. Details and full argumentations are given in (1).

## 2. Discharges

Most of the discharge figures used in the calculations are taken equal to the existing or expected license discharge limits. The isotopic compositions are taken in a conservative manner from experiences with the existing plants. The figures for the 1000 MWe plants to be built are given in table 1.

## 3. Exposure of the population

The exposure of the population has been calculated, taking into account several forms of exposure given in table 2. The doses for a site in the centre of the country are given as an example. For comparison of the doses of different organs the ratios of the acceptable limits for the public can be used. If compared with the whole body dose, the lung dose has to be divided by 3, the skin dose by 6 and the thyroid dose by 3 for children and by 6 for adults; taking into account the population and dose distributions, the average factor appears to be 4. The risk appears to be determined by the whole body dose.

The dispersion of gaseous effluents has been calculated with the model MIKRO, which uses the gaussian plume model, variation of wind speed with height, maximum mixing heights, plume rise, rainout, radioactive decay during transport.

- Some remarks can be made about the different forms of exposure:
- to 1) Individual and population doses are calculated, using the yearly meteorological parameters of the meteorological station nearest to the site under consideration. The real population density (1971-1974) is used, counted in 192 regions formed by 16 radii and 12 circles up to a distance of 100 km. For the external  $\gamma$ -radiation a shielding factor 1/3 is used. The beta radiation of the effluents gives a skin dose.
  - to 2) The particulates are assumed to be insoluble and lung doses are calculated using the 1959 ICRP-2 model.
  - to 3) Contamination of the ground is calculated by assuming no removal other than by radioactive decay.
  - to 5) The population dose from milk consumption is estimated using the real distribution of grassland around the sites. The contamination of the grass is calculated as a function of distance and direction, taking into account a removal half life of 12 days. The given dose is caused by the direct consumption (average delay about 4 days) of the milk (about 20% of the total production).
  - to 6) The dose caused by contaminated vegetables and fruit appeared to be negligible.
  - to 7) Considering the fact that part of the water used as drinking water comes from outside the country (Rhine), the dose via the drinking water pathway is estimated in the same way as stated under 8.
  - to 8) The population dose caused by the HTO discharge via the ventilation stack is estimated very conservatively by assuming that all HTO discharged is washed out with the rainwater above the country and that every inhabitant takes up 0.4 m<sup>3</sup>/year of this contaminated water via the food.
  - to 9) The site taken as an example is one of the few sites where part of the cooling water reaches drinking water basins.
  - to 10) The dispersion of radionuclides in rivers, coastal parts and estuaries of the North Sea is calculated and the specific activity of the fish is determined using concentration factors from literature. Using the amounts of this fish consumed in the country an estimation is made of the total population dose.
  - to 11) The Fievo site is situated on the Ysselmeer and the fish caught in this lake is processed in the food for porkers and hens. Therefore the dose caused by eating the resulting meat and eggs is estimated using very conservative pathway parameters.

Remark: The discharge of C-14, about 10 Ci/a per 1000 Mwe, has not been included in the tables. The aspect of C-14 contamination by food consumption is in consideration, the collective dose for the Dutch population is estimated to be a few manrem/year.

#### 4. Conclusions

From the results of the calculations for the different sites it could be concluded that the collective whole body dose received by the Dutch population as a result of the normal discharges from nuclear power plants with a total capacity of 3500 Mwe is less than 70 manrem per year (the doses caused by the indivi-



dual plants vary from 3 to 30 manrem). The natural background delivers 1 500 000 manrem/year to the Dutch population.

Using the conservative linear dose-effect relation and the risk figures of the BEIR-report (1972), which neglects possible repair effects at low dose rates, the risk of 70 manrem/year can be estimated to be in the order of one case of leukaemia in 500 years and one death caused by some other type of cancer in 80 years, whereas the "natural" incidence of these diseases in our country is 1000 and 25 000 to 50 000 per year respectively. Based on a mutation doubling dose of 100 rem, recently suggested as a reasonable approximation, the number of genetic deficiencies will be 1 per 3000 years in the first generation (equilibrium value 1 per 300 years, natural incidence 19 000 per year). This means that even in our densely populated country the normal effluents from the power plants cause a completely negligible (if any) risk for the population.

The dose to the workers inside the plant is expected to be much higher, maybe as high as about 2000 manrem per year for the five plants, which means a 30 times as high risk to a smaller group of persons, so that any possible repair by the immune system will sort out less effect than in the case of population exposure. Therefore much attention is paid to dose reduction during maintenance operations in the power plants. The fact that reduction of the discharge of radioactivity from the plant can increase the dose inside the plant may more than counterbalance the reduction of radiation effect to the public.

#### References

- (1) Risico-analyse van de splijtstofcyclus in Nederland; N.V. Samenwerkende Elektriciteits- en productiebedrijven (summary in English available)

Table 1 Discharges via the ventilation stack for a 1000 MWe plant (Ci/a)

noble gases <sup>1)</sup>	I-131	other halogens <sup>2)</sup>	particulates <sup>3)</sup>	tritium
20 000	0.5	2.0	0.2	10 or 100 <sup>4)</sup>

1) 10% Kr-85; 75% Xe-135; 15% Xe-135

2) 90% I-133; 10% I-135

3) 9% Mo-99; 5% Co-58; 20% Cr-51; 20% Mn-54  
5% Sb-124; 20% Co-60; 20% Fe-59; 1% Cs-137

4) 100 Ci/a for a PWR, 10 Ci/a for a BWR

#### Liquid effluents from a 1000 MWe plant

All nuclides <sup>1)</sup> (except H-3)	5 Ci/a
H-3	100 Ci/a BWR 1000 Ci/a PWR
1) 7% Mn-54; 20% Co-58; 20% Co-60; 10% Sr-89; 0.5% Sr-90; 10% I-131; 10% Cs-134; 15% Cs-137; 5% Ba-140-La-140; 2.5% rest	

Table 2 Exposure forms and population doses for a 1000 MWe PWR at the Flevo-site  
(centre of the country)

ref. nr.	dis-charge point	effluent	transport	exposure form	population dose (manrem/year)				
					whole body	lung	thyroid	skin	
1	ventilation stack	noble gases	atmosphere	external radiation	.7	.7	.7	8	
2		particulates	atmosphere	inhalation		.07			
3		particulates	deposition on ground	external radiation	2.8	2.8	2.3	2.8	
4		halogens	atmosphere	inhalation			3.0		
5		halogens	deposition on grass	milk consumption			48		
6		halogens	deposition on vegetation	vegetables and fruit			.3		
7		tritium	rainout and wash out	drinking water	<1.6	<1.6	<1.6	<1.6	
8		tritium	rainout and wash out	food	<5	<5	<5	<5	
9		cooling	fission and corrosion products	waterways	drinking water	3.1	.7	.5	
10				food pathways	fish	2.2	.6	.01	
11				food pathways	meat and eggs	2.4	.6		
12			tritium	waterways	drinking water	2	2	2	2
total dose					20	14	64	19	
comparison with whole body dose					20	5	16	3	

## COLLECTIVE POPULATION RADIATION EXPOSURE FROM WASTE DISPOSAL FROM A FUEL REPROCESSING PLANT

D. F. Jefferies and N. T. Mitchell  
Fisheries Radiobiological Laboratory, Lowestoft, Suffolk, UK  
J. A. Hetherington  
Scottish Development Department, Edinburgh

### 1. INTRODUCTION

The most important pathways to public radiation exposure from controlled discharges of liquid radioactive waste from the nuclear power programme in the UK are due to fuel reprocessing operations. In this respect, the predominant radio-nuclides which go to make up the effluent released from British Nuclear Fuels Ltd, Windscale into the Irish Sea under joint authorization of the Department of the Environment and the Ministry of Agriculture, Fisheries and Food are caesium-137 and -134. In the marine environment caesium behaves in an essentially conservative fashion and though some associates with sediment, most stays in the water and disperses from the area of discharge off the Cumbrian coast as this water moves through the Irish Sea and mixes with further distant waters, mainly those around the mainland of Scotland.

These waters support important fisheries and the nonconsumption of fish thus provides one of the critical pathways for Windscale discharges. Because of the extent of the area through which radiocaesium of Windscale origin can be detected, the size of the fish stocks and the large population consuming them, consideration of this pathway should not be restricted to the dose to the critical group of most highly exposed people. In these circumstances, where large populations are exposed to low doses the ICRP recommends that the control procedure should take into account the integrated collective dose as well as the dose to the critical group. Assessment of collective dose is essential not only in relation to the control of the genetically effective dose but also because it forms an essential component of the optimization procedure required to meet the principle of keeping doses as low as reasonably achievable (1, 2).

### 2. THE DISTRIBUTION OF RADIOCAESIUM IN BRITISH ISLES COASTAL WATERS AND NEARBY

Radiocaesium nuclides form part of the low-level radioactive liquid waste which is discharged from Windscale into the north-east Irish Sea. After discharge the caesium mixes with the sea water which is transported through the Irish Sea in a northerly direction so that most of the radioactivity is eventually removed via the North Channel. A small amount is carried southwards, as has been shown by surveys from this laboratory during which caesium at higher than fallout levels and attributable to Windscale has been detected in the Celtic Sea and the Bristol Channel. Once out beyond the North Channel the water begins to mix with the north-east Atlantic water. However, surveys for caesium have shown that the rate of mixing is slow, with most of the water from the Irish Sea moving in a well defined path northward along the west coast of Scotland and into the North Sea (3). The hydrography of the North Sea is complex; caesium entering from the north-west is found at varying concentrations throughout much of it and can still be detected in the water flowing out into the Norwegian Sea. Details of concentration are reported elsewhere (3, 4). On the present evidence dilution factors in the Irish Sea relative to the immediate vicinity of the release point are about 20 to 30 to the North Channel and

10 to 20 to Anglesey. Between the North Channel and Cape Wrath there is a dilution of about 5 to 10 and a further small dilution between there and the northern North Sea. However, due to variations in the rate of release of radiocaesium from Windscale and to short-term variation in the pattern of water movement, these factors are likely to change especially at the greater distances from Windscale. The times of transit between the points referred to are long, for example about 0.5-1 year from the Cumbrian coast to the North Channel and a similar time scale to Cape Wrath. These times are comparable to the radioactive half life of caesium-134 and the concentrations of this radionuclide at distance are therefore being reduced significantly by radioactive decay.

### 3. THE CALCULATION OF COLLECTIVE DOSE

The formal definition of collective dose rate is

$$S = \int_0^{\infty} H N_H(H) dH$$

where  $N_H(H)$  is the population spectrum in dose rate and  $N_H(H) dH$  the number of individuals receiving a dose in the range  $H$  to  $H + dH$ . A more directly applicable formulation is given by the summation

$$S = \sum_j H_j N_j$$

where  $H_j$  is the per caput dose rate in population group  $j$  of size  $N_j$ . When applied to internal irradiation from the consumption of fish containing radioactivity  $H = k W_j C_j$ , where  $W_j$  is the mean consumption rate of population  $j$  and  $C_j$  the mean concentration in their intake of fish. The constant of proportionality,  $k$ , relates the rate of intake of each radionuclide to dose and may be obtained from ICRP II (5).  $W_j$  may be replaced by  $Q_j/N_j$  where  $Q_j$  is the total catch of fish consumed by population  $N_j$  and the above equation reduces to

$$S = \sum k Q_j C_j$$

The collective dose for any given population may be computed therefore by using the statistics on fish landings compiled by ICES (6) together with the measurements of radioactivity in fish samples. For the present purposes data on fish landings have been corrected to take account of the non-edible fraction such as bone and viscera. This probably leads to an overestimate of the amounts consumed because no allowance has been made for other wastage. On the other hand, no allowance has been made for the contribution to the human diet from the more tenuous routes which begin with "industrial fish" stocks which are used to produce fish meal and provide feedstock for cattle, pigs and poultry, etc.

In view of the size of the area over which caesium from Windscale is detectable the calculation of collective dose might at first sight seem to require the measurement of radiocaesium in a large number of samples of fish. Whilst in practice the fish stocks are surveyed as comprehensively as possible with special attention to those responsible for most of the dose, it is possible to make reasonable estimates of the concentration in fish from a knowledge of the concentrations of radiocaesium in water and the concentration factors for the nuclide between fish and water. This approach has been used to supplement the direct measurements on fish and especially to take account of the contributions from fish stocks which are difficult of access such as some of the landings made by other countries.

#### 4. RESULTS AND DISCUSSION

The Western European shelf waters in which Windscale-derived radiocaesium can be detected have been fished by a number of European countries in addition to the UK, notably the Republic of Ireland, France, Belgium, the Netherlands, Denmark, West Germany, Norway and the USSR. The more distant waters around Scotland, the North and Norwegian Seas are also fished by a number of different countries.

Collective doses from radiocaesium in 1974 and 1975 have been calculated separately for the UK and for other Western European nations, notably those listed above. The results are shown in Table 1. Most of the dose is due to caesium-137 but account has also been taken of the contribution of caesium-134. Also shown is the average *per capita* dose rate for the countries concerned and these have been related to the population dose limit adopted by the UK (7) for the control of radiation exposure from waste disposal operations. This limit was set on mainly genetic considerations at 1 rem per person in 30 years, that is equivalent to 33 mrem per person per year, and is used rather than any current ICRP limit. The only relevant advice from the Commission is a higher overall limit of 5 rem per generation but this is not specific to waste disposal.

Population (and size)	Collective dose rate, man rem/yr		Mean per caput dose			
			m rem/person/ yr		% of UK max.	
	1974	1975	1974	1975	1974	1975
UK (5.5 x 10 <sup>7</sup> )	4.8 x 10 <sup>3</sup>	8.3 x 10 <sup>3</sup>	0.09	0.15	0.24	0.45
Other W European nations (1.4 x 10 <sup>8</sup> )	3.8 x 10 <sup>3</sup>	5.7 x 10 <sup>3</sup>	0.03	0.04	0.08	0.12

TABLE 1 Collective dose rates of Windscale radiocaesium discharges through the fish consumption pathway, 1974-75

The difference in collective doses between 1974 and 1975 is mainly due to an increase in the discharge rate of radiocaesium from Windscale during 1974. Due to the time it takes for caesium to reach the more distant water masses and the time lag in it working its way through the food chain to the fish eaten by man, little effect of this increased discharge was seen in 1974. The full effect of the higher rate of discharge in the distant waters such as the North and Norwegian Seas has even yet to be seen. However, because the contribution to total collective dose from these areas is small, the total collective dose may not increase even when the higher rate of discharge does eventually reflect in these more distant waters. By that time it is expected that measures which have been taken to reduce discharges will be taking effect with the result that the rate of fall in the contribution to total dose from the Irish Sea stocks will be greater than the rate of increase of that from the more distant areas.

In addition to providing the means of quantifying the genetically effective dose from this discharge of radiocaesium and of demonstrating compliance with national policy

objectives on average population dose, assessment of the integrated population dose is needed in order to demonstrate that the philosophy of keeping doses "as low as is reasonably achievable" is being honoured. An essential piece of information when coming to a scientifically based decision concerning the reduction of discharges is how far reduction is cost-effective and therefore justified on radiological/economic grounds; furthermore, it provides a logical basis for choice of the best means of achieving any desired reduction. Decisions to reduce the rate of discharge are bound to cost money; they are likely also to result in higher doses being received by the people who will operate the effluent treatment equipment and handle the caesium reconcentrated from the effluent. Before embarking on a programme to reduce discharges it should be ascertained that the costs of so doing (including those associated with the integrated dose to the operators) are not out of proportion to the savings in the detrimental cost associated with not discharging the waste.

The detrimental cost of discharging may be calculated by assuming a linear relationship between dose and effect as recommended by ICRP. This permits an estimate to be made of the total damage in terms of radiation-induced deaths attributable to the discharge in the exposed population. The total damage may be translated into financial terms by considering how much it is deemed that society is prepared to pay in order to avoid death. This last figure is not an easy one to arrive at, involving as it does the quantification of pain, suffering and life itself but is necessary to provide a sound scientific/economic basis for a waste management policy. Shepherd and Hetherington (2) have discussed the question of the cost appropriate to the prevention of one man rem of exposure to the general public and deduced a figure of £50 per man rem. When applied to the discharge of radiocaesium from Windscale during 1975, for example, when the total collective dose was about  $1.4 \times 10^4$  man rem the total detrimental cost was approaching £1 M. This figure provides a context in which the cost of methods of effluent treatment and caesium extraction facilities may be viewed. Any treatment process whose discounted capital plus annual running costs significantly exceed this amount would be difficult to justify economically whereas any measure costing significantly less would merit further investigation to see how its costs compared with the detrimental cost savings from its use.

#### REFERENCES

- (1) ICRP-22. Implications of Commission recommendations that doses be kept as low as readily achievable, ICRP Pub. 22, Pergamon Press, Oxford (1973)
- (2) SHEPHERD, J. G., HETHERINGTON, J. A., Observations on the use of cost-benefit analysis in the control of radioactive waste disposal, Tech. Rep. MAFF Fish. Lab. (17) (1975)
- (3) JEFFERIES, D. F., PRESTON, A., STEELE, A. K., Distribution of caesium-137 in British coastal waters, Mar. Pollut. Bull. 4 (1973) 118
- (4) JEFFERIES, D. F., Further studies on the distribution of radiocaesium in British coastal waters. To be published.
- (5) ICRP-2. Report of Committee II on Permissible Dose for internal Radiation, Pergamon Press, Oxford (1959)
- (6) Bull. Stat. de Pêche Mar., International Council for the Exploration of the Sea, Denmark
- (7) ANON., The Control of Radioactive Wastes, Cmnd 884, HMSO, London (1959)

## EFFLUENTS RADIOACTIFS ET ENVIRONNEMENT DES CENTRALES NUCLEAIRES

J.J. MARTIN - Département de Radioprotection  
Ph. ROLLIN - Département Exploitation

ELECTRICITE DE FRANCE - Service de la Production Thermique  
3, Rue de Messine 75008 - PARIS

## 1. INTRODUCTION

Les effluents radioactifs des centrales nucléaires d'Electricité de France font l'objet d'un contrôle à la source. On va décrire les méthodes appliquées sur les huit tranches actuellement en service et qui seront utilisées sur les quinze tranches en cours de construction.

Des mesures dans l'environnement sont exercées simultanément par l'Exploitant nucléaire et le Service Central de Protection des Rayonnements Ionisants (S.C.P.R.I.) du Ministère de la Santé. Le calcul de la dose supportée par le public est présenté en soulignant le caractère volontairement majorant de cette évaluation.

## 2. CONTROLE DES EFFLUENTS

Les méthodes appliquées pour les effluents gazeux et liquides sont légèrement différentes, les premiers étant rejetés en continu avec l'air de ventilation, les seconds transitant par un réservoir de contrôle avant rejet.

## 2.1. Effluents gazeux

Les effluents gazeux sont constitués essentiellement par l'air de ventilation qui est contaminé par les fuites des circuits actifs. Les vidanges de réservoirs de gaz actifs dans les PWR ou du circuit primaire dans les réacteurs graphite-gaz ne contribuent que pour une faible part aux rejets, en raison de la réduction d'activité apportée par la décroissance radioactive.

Tous les effluents gazeux transitent par des cheminées, en nombre le plus réduit possible, où l'on s'attache à avoir un débit relativement constant. Il existe cependant quelques cas de cheminées affectées aux rejets de gaz carbonique où le débit est intermittent. Chaque cheminée est équipée (Figure 1) de prises isocinétiques réparties selon un diamètre de la cheminée. L'air prélevé passe simultanément à travers une chambre compensée qui donne une mesure continue  $\beta$  globale des gaz filtrés (étalon de référence : 85 Kr), et un ensemble de deux filtres, un filtre papier retenant les aérosols et un piège charbon fixant les produits volatils. Le charbon est un charbon de houille imprégné à l'iodure de potassium, de 3 cm d'épaisseur, traversé par l'air à une vitesse inférieure à 0,5 m/s ; on s'est assuré que son efficacité était meilleure que 90 % pour les formes pénétrantes de l'iode et une utilisation continue d'une semaine. Un compteur GM placé au-dessus des filtres donne une indication de l'activité déposée sur les filtres et une alarme en cas d'évolution importante au-dessus du niveau d'équilibre obtenu avec les descendants solides des gaz rares à vie courte qui sont piégés par le filtre. Il faut noter que le piège charbon retient également temporairement les gaz rares. Le filtre et le piège sont changés chaque semaine et mesurés en laboratoire.

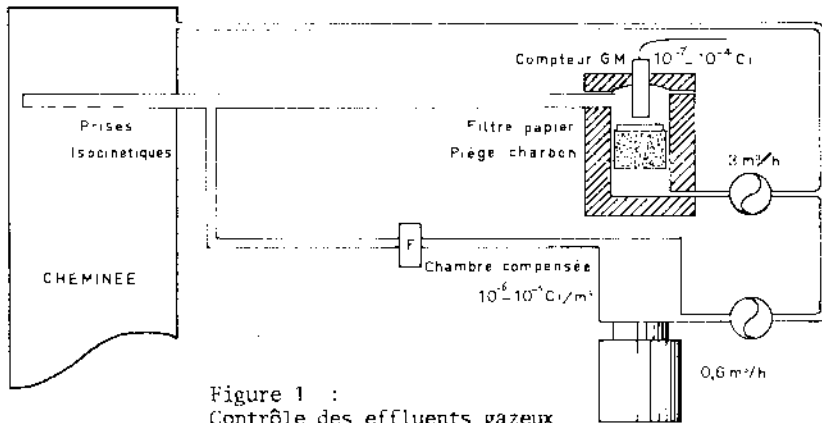

Figure 1 :  
Contrôle des effluents gazeux

## 2.2. Effluents liquides

Tous les effluents liquides actifs ou susceptibles de contamination sont collectés après traitement dans des réservoirs de contrôle. Lorsqu'un réservoir est plein, on procède à l'homogénéisation du contenu par brassage, puis au prélèvement d'un échantillon qui est mesuré au laboratoire.

Lorsque l'on dispose du résultat de cette mesure, le réservoir peut être vidangé au débit approprié pour que, compte tenu du débit du cours d'eau au moment du rejet, l'activité volumique dans le cours d'eau après dilution supposée parfaite de l'effluent ne dépasse pas la valeur fixée par l'autorisation de rejet.

## 2.3. Mesure

Les échantillons prélevés sont analysés au laboratoire de la centrale :

- le filtre aérosols en  $\beta$  global (étalon  $^{90}\text{Sr} + \text{Y}$ ), éventuellement en spectrométrie  $\gamma$ ,
- le piège charbon en spectrométrie  $\alpha$ ,
- l'eau des réservoirs en  $\beta$  global, éventuellement en spectrométrie  $\gamma$  avec mesure spécifique du  $^{90}\text{Sr}$ , et en tritium.

Chaque trimestre, un échantillon de chaque type (filtre, piège, eau) est adressé au Département de Radioprotection d'Electricité de France pour analyse contradictoire et contrôle de la qualité des mesures faites par la centrale. De plus, chaque mois, un échantillon est adressé au S.C.P.R.I. qui exerce un contrôle indépendant de celui de l'exploitant nucléaire.

Chaque mois, la centrale établit un état des rejets d'effluents gazeux et liquides qui est adressé au Département de Radioprotection et au S.C.P.R.I.

Les résultats des rejets des années 1971 à 1976 sont reportés aux tableaux 1 et 2.



TABLEAU 1 - Rejets gazeux des centrales nucléaires

Centrales	CHINON		ST.LAURENT		BUGEY		CHOOZ	
	GR	APV	GR	APV	GR	APV	GR	APV
1971	4,2	18	3,4	47			6,6	n.m.
1972	12	610	3,9	140	0,8	0,7	31	24
1973	2,8	42	5,0	37	3,1	9,6	20	160
1974	2,1	18	4,3	20	4,5	21	1,5	12
1975	6,0	31	3,5	17	5,3	24	2,7	410
1976	4,9	20	2,9	13	3,1	9	4,9	47

TABLEAU 2 - Rejets liquides des Centrales nucléaires

Centrales	CHINON		ST.LAURENT		BUGEY		CHOOZ	
	$\beta$	$^3\text{H}$	$\beta$	$^3\text{H}$	$\beta$	$^3\text{H}$	$\beta$	$^3\text{H}$
1971	2	n.m.	2,2	n.m.			34	700
1972	3	"	9,4	"	0,1	n.m.	12	1800
1973	3,3	"	7,3	"	1,6	"	8,2	1900
1974	0,4	"	4,2	400	60	820	8,6	3300
1975	0,7	150	4,7	700	14	240	8,6	2500
1976	0,6	100	3,0	500	3,6	200	2,6	1900

GR : gaz rares (kCi) - APV : aérosols et produits volatils (mCi)

$\beta$  : activité  $\beta$  globale des liquides (Ci) -  $^3\text{H}$  : tritium (Ci)

n.m. : non mesuré

### 3. ENVIRONNEMENT

Autour de chaque centrale, Electricité de France et le S.C.P.R.I. procèdent aux prélèvements suivants, pour mesures séparées dans leurs laboratoires :

- aérosols à la limite du site sous les vents dominants,
- eau de pluie à la limite du site sous les vents dominants,
- eau de rivière et sédiments en amont et en aval du site,
- eau de la nappe phréatique (E.D.F. seulement)
- lait prélevé dans les fermes proches (E.D.F. seulement)
- végétaux sous les vents dominants (E.D.F. seulement).

A ces prélèvements systématiques s'ajoutent des prélèvements adaptés à la nature du site et de fréquence variable : eau de boisson, poissons ... Des mesures supplémentaires destinées à faire le point zéro des sites, préalablement à leur mise en service, sont confiées à des laboratoires extérieurs des Universités ou du Commissariat à l'Energie Atomique.

Jusqu'à ce jour, autour des sites en service, seuls les prélèvements d'eau de rivière et de sédiments permettent de mettre en évidence une contamination significative apportée par les rejets de la Centrale. L'activité volumique, ajoutée à l'eau de rivière est, au plus, de l'ordre de la moitié de la radioactivité pré-existante véhiculée par la rivière, et inférieure au millième de la concentration maximale admissible (C.M.A.P.) dans l'eau de boisson pour les personnes du public (tableau 3), lorsque celle-ci peut être déterminée avec précision.

TABLEAU 3 - Activité volumique en rivière Hors Tritium ( $10^{-9}$  Ci/m<sup>3</sup>)

Cours d'eau	LOIRE		RHONE		MEUSE	
	CHINON & ST. LAURENT		BUGEY		CHOIZ	
	1975	1976	1975	1976	1975	1976
Centrales						
Activité en amont	5,5	6,2	6,9	3,8	4,5	5,2
Activité ajoutée	0,5	0,33	1,0	0,5	2,5	1,6
C.M.A.P.	100(1)	100(1)	11 000(2)	2400(2)	9000(2)	6400(2)

(1) - Valeur prudente pour un mélange inconnu

(2) - Valeur tenant compte de la composition des effluents

#### 4. EVALUATION DES DOSES

A partir des mesures détaillées sur les effluents, il est possible de calculer les doses supportées par le public du fait des rejets, à défaut de pouvoir les déterminer directement dans l'environnement. L'évaluation tient compte des différentes voies possibles d'irradiation : immersion dans le nuage de gaz rares à l'endroit habité le plus exposé, inhalation d'air contaminé au même emplacement, consommation de lait contaminé par les dépôts sur les herbages et du fait de l'abreuvement de la vache en eau de rivière contaminée, consommation d'eau de rivière en tant qu'eau de boisson, consommation de poissons vivant en aval de la centrale, consommation de légumes irrigués.

A titre d'exemple, la dose à l'organisme entier de la personne cumulant ces différentes irradiations a été évaluée en 1975 pour les centrales de CHOIZ et de BUGEY, respectivement à 0,5 et 1 millirem par an.

#### 5. CONCLUSION

Les contrôles exercés par Electricité de France sur les rejets de ses centrales nucléaires montrent que la dose évaluée de manière majorante pour les personnes du public est inférieure au centième de la dose résultant des rayonnements naturels. Les contrôles exercés par le Ministère de la Santé constituent une garantie pour le public que ces rejets resteront aussi bas que possible.

EVALUATION DES DOSES COLLECTIVES ET COMPARAISON  
DES DOSES INDIVIDUELLES MOYENNES ET MAXIMALES RESULTANT  
DES RISQUES D'INGESTION DE LAIT FRAIS ORIGINAIRE D'UNE  
REGION SOUMISE A L'INFLUENCE DE REJETS ATMOSPHERIQUES CONTINUS

A. GARNIER  
Département de Protection  
Commissariat à l'Energie Atomique  
BP N° 6, 92 260 Fontenay-aux-Roses, France

## 1. INTRODUCTION

L'évaluation des doses collectives concernant un groupe de population donné nécessite, par rapport à celle des doses aux individus des groupes critiques, un complément d'information et des méthodes nouvelles.

On se propose, ici, à titre d'exemple, d'évaluer dans des conditions moyennes, l'ordre de grandeur des doses collectives dues à l'ingestion pouvant résulter de rejets unitaires continus et affectant une zone de rayon donné entourant le point de rejet ; et, en même temps, de situer les niveaux moyens et extrêmes des doses individuelles, par rapport à ceux concernant les groupes critiques. Contrairement à l'étude d'un site particulier, pour lequel on peut disposer de toutes les informations détaillées, celle d'un cas général repose nécessairement sur des données moyennes, mais dont la variabilité peut être cernée dans une certaine mesure suivant certains scénarios.

En ce qui concerne la contamination des produits agricoles, on peut se baser sur les pourcentages moyens des surfaces occupées par rapport à la superficie totale.

Diverses hypothèses sont alors possibles :

- supposer les cultures uniformément réparties
- imaginer des schémas d'utilisation des surfaces permettant de calculer des niveaux moyens et extrêmes de la contamination des cultures, selon leur emplacement par rapport à la source de pollution.

Aux stades de la collecte et de la distribution des produits, des hypothèses identiques peuvent également conduire à une évaluation de la variabilité des niveaux résultants, complétant celle des niveaux moyens.

Prenons pour exemple, le cas des produits laitiers originaires d'une zone où existerait un rejet continu d'iode  $^{131}$  ( bien que, en fait, le risque de contamination par ingestion de lait soit surtout à considérer en cas de rejet accidentel ).

## 2. CALCUL DE LA CONTAMINATION MOYENNE DES PRODUITS

La relation entre la contamination du lait à la production  $C_{Lp}$  ( $Ci\ l^{-1}$ ) et la contamination atmosphérique au niveau du sol à la distance  $x$  de la source  $\chi(x)$  ( $Ci\ m^{-3}$ ) est :

$$C_{Lp} = \bar{C}(x) \times 1,22 \cdot 10^3$$

avec les hypothèses suivantes :

- vitesse apparente de dépôt :  $10^{-2}$  m.s<sup>-1</sup>
- vie moyenne effective de l'iode <sup>131</sup>I sur l'herbe : 7 jours
- fraction de la contamination retenue par la partie comestible de la plante : 0,25
- surface broutée par la vache :  $100 \text{ m}^2 \text{ j}^{-1}$
- fraction de la quantité ingérée par jour sécrétée par litre de lait : 0,008.

Pour le calcul des doses individuelles au groupe critique, il suffirait de calculer  $C_{L \text{ max}}$  correspondant à la distance  $x_{\text{max}}$  de concentration maximale  $C_{\text{max}}$ . Pour l'évaluation des doses moyennes individuelles ou des doses collectives, concernant un groupe de population donné, une autre démarche est nécessaire : d'une part, le lait est produit en des zones différemment contaminées. D'autre part, une importante fraction de la production laitière ( 72% en France ) est collectée, et la partie de cette collecte destinée à la consommation humaine est traitée par les usines afin d'obtenir des laits et produits frais standardisés, dont la consommation est environ de 0,2 l par personne et par jour en moyenne ( en France ), le complément de la ration étant apporté par des laits concentrés et en poudre.

Il en résulte évidemment que les niveaux de contamination du lait consommé par l'individu du groupe critique, d'une part, ou l'individu de la population dans son ensemble, d'autre part, sont très différents.

Essayons d'évaluer les concentrations moyennes d'iode <sup>131</sup>I dans le lait produit dans une zone de 50 kilomètres de rayon autour d'un point de rejet. D'après les données nationales françaises, la surface toujours en herbe ( STH ) représente 22,4% de celle du territoire, et la production moyenne est de 22,8 hl/ha, soit, pour la zone considérée, environ 405 000 tonnes par an, dont la collecte pourrait être effectuée par au moins dix établissements différents ( d'après les chiffres fournis par l'étude de la structure des établissements laitiers ). La contamination du lait dépend donc de la localisation des zones de production et de ramassage. Trois cas de figure peuvent être envisagés pour calculer tout d'abord les valeurs moyennes et extrêmes de la concentration qui résulterait d'un mélange total, selon que la surface toujours en herbe occupe un secteur ( cas 1 ), un cercle autour de la source ( cas 2 ) ou une couronne circulaire à la limite du périmètre étudié ( cas 3 ).

Trois cas peuvent être considérés respectivement comme moyen, défavorable, et favorable, en raison des niveaux de concentration pris en compte.

La concentration moyenne  $\bar{C}_{Lp}$  en <sup>131</sup>I dans la production cumulée en fonction de la distance à la source jusqu'à 50 km est calculée dans ces trois cas ( pour une hauteur de rejet de 100 m, et des conditions de diffusion atmosphérique moyennes ).

Les valeurs trouvées en cas de mélange total, exprimées en Ci l<sup>-1</sup> par Ci s<sup>-1</sup> rejeté, sont les suivantes :

Cas 1 :  $3,3 \cdot 10^{-6}$   
 Cas 2 :  $8,4 \cdot 10^{-6}$   
 Cas 3 :  $1,2 \cdot 10^{-6}$ .

Mais en réalité, un certain nombre d'établissements ( peut être une dizaine ) participent à la collecte. Supposons que les 10% les plus contaminés soient ramassés par le même établissement : la limite de ramassage se situe à 15,8 km dans le cas 1 ( secteur ) et à 7,5 km dans le cas 2 ( cercle ), d'où les concentrations moyennes dans le 1/10ème le plus contaminé :

Cas 1 :  $1,35 \cdot 10^{-5}$  Ci l<sup>-1</sup> par Ci s.<sup>-1</sup> rejeté  
 Cas 2 :  $2,8 \cdot 10^{-5}$  " " "

soit respectivement quatre fois plus et 3,3 fois plus que précédemment ( dans le cas 3, un calcul identique n'aurait aucun sens ). La concentration du 1/10ème le plus contaminé du cas 2 est 23 fois plus élevée que la concentration moyenne dans le cas 3, et 8,5 fois plus élevée que la concentration moyenne dans le cas 1 en cas de mélange total.

### 3. VALEURS PROPOSEES

Pour le calcul des doses individuelles et collectives résultant de l'ingestion d'iode 131 par la population dans son ensemble, on pourrait proposer un intervalle de  $3 \cdot 10^{-6}$  à  $3 \cdot 10^{-5}$  Ci l<sup>-1</sup> par Ci. s<sup>-1</sup> rejeté, soit  $10^{-5}$  Ci l<sup>-1</sup> par Ci.s<sup>-1</sup> avec un facteur d'incertitude de 3 dans l'un ou l'autre sens : c'est le 1/100ème de la valeur calculée à la distance de concentration maximale avec un coefficient de dilution atmosphérique de l'ordre de  $10^{-6}$  s.m<sup>-3</sup>.

Par Ci an<sup>-1</sup> rejeté, les valeurs correspondantes seraient de l'ordre de 0,1 à 1 pCi l<sup>-1</sup>, avec une moyenne de 0,3.

Le schéma proposé peut également rendre compte, approximativement, de l'influence de la variabilité régionale de la proportion des surfaces toujours en herbe ( STH ). Par exemple, dans le cas où la STH serait de 2,24%, soit le 1/10ème de la moyenne nationale, et située à proximité immédiate de la source, la concentration moyenne du lait serait égale à celle du 1/10ème le plus contaminé ; et dans celui où la STH serait de 100%, la concentration serait égale à celle résultant du mélange de la production cumulée jusqu'à la distance de 50 km.

Toutes ces estimations moyennes reposent sur l'hypothèse suivant laquelle les vitesses de dépôt et les facteurs de transfert seraient uniformes. Il est bien évident que la variabilité régionale des concentrations dépend des variations concomitantes des différents paramètres, mais on peut les négliger en première approximation dans le cas général, lorsqu'il s'agit de rejets continus.

### 4. CALCUL DES DOSES A LA THYROIDE

La production laitière moyenne, en France, d'une zone de 50 km de rayon est de  $4,05$  Mhl.an<sup>-1</sup>, dont environ 14% sont consommés sous forme de lait et produits frais, à raison d'environ 0,2 l par personne et par jour, par  $7,8 \cdot 10^5$  consommateurs de toutes classes d'âge habitant ou non la région de production. Connaissant la répartition moyenne de la population par classes d'âges, d'après les statistiques nationales, et l'évolution.

des consommations d'après divers résultats d'enquêtes, on a adopté pour le calcul les valeurs suivantes des consommations moyennes de lait frais.

Classe d'âge N	nZ	P ( l j <sup>-1</sup> )	nP
0 - 1 an	1,66	0,55	0,91
1 - 2 ans	1,67	0,47	0,78
3 - 9 ans	13,08	0,35	4,58
10 - 14 ans	8,05	0,27	2,18
15 - 19 ans	8	0,2	1,6
20 ans	67,54	0,15	10,1
	-----		-----
	100		20,15

d'où résulte une moyenne pondérée de 0,2 l j<sup>-1</sup>. Les paramètres radiobiologiques évoluent avec l'âge de telle façon que le produit  $f_w T \frac{E}{m}$  varie de 0,18 pour le nourrisson à 0,025 pour l'adulte. La dose collective résultant de l'ingestion du lait produit dans la zone contaminée est

$$D_{coll} = \bar{C} \times 2,7 \cdot 10^{10} \times 7,8 \cdot 10^5 \sum_N \frac{n_N P_N (f_w T \frac{E}{m})}{100} N$$

soit

$$\frac{D_{coll}}{\bar{C}} = 2,3 \cdot 10^{14} \text{ pers. rem an}^{-1} \text{ par Ci l}^{-1}$$

ou, par Ci an<sup>-1</sup> rejeté, une dose collective de l'ordre de 73 personnes-rem par an ( dont 10 à la classe d'âge de 0 à 1 an ), avec une variabilité d'un facteur 3 dans l'un ou l'autre sens selon la structure de la production et de la collecte. Les doses individuelles moyennes sont inférieures à 0,1 mrem an<sup>-1</sup> pour l'ensemble ( de 0,03 pour l'adulte à 0,8 pour la classe 0 - 1 an ) toujours affectés du même facteur 3, alors que la dose à l'individu du groupe critique dans les conditions précédemment indiquées va de 3,8 mrem an<sup>-1</sup> pour l'adulte à 100 mrem an<sup>-1</sup> pour le nourrisson.

## 5. CONCLUSION

Cet exemple montre la marche à suivre pour évaluer le degré de protection ( supérieur à deux ordres de grandeur ) dont bénéficie la population dans son ensemble par l'application du critère de limitation basé sur la dose à l'individu le plus exposé du groupe critique.

ESSAIS IN SITU DES PIÈGES A IODE

R. SCHNEPF

ELECTRICITE DE FRANCE - DEPARTEMENT DE RADIOPROTECTION  
6, Rue Ampère SAINT-DENIS (France)1. - INTRODUCTION

La nécessité de limiter les rejets de matières radioactives dans l'environnement a conduit à la mise en place, dans les centrales nucléaires, de dispositifs d'épuration des effluents gazeux et liquides.

En ce qui concerne les effluents gazeux, ces dispositifs sont constitués de filtres absolus (rétention des aérosols) d'une part, et de pièges à iode d'autre part.

Afin de s'assurer du bon fonctionnement de ces appareils, un certain nombre de dispositions ont été adoptées, permettant d'en réaliser des essais représentatifs "in situ".

La présente communication a pour objet, après un bref rappel du problème de l'iode, de présenter la méthode d'essai in situ employée en France pour tester l'efficacité des pièges à iode rencontrés dans les centrales nucléaires.

2. - RAPPELS SUR L'IODE

L'iode radioactif qui serait relâché par une installation nucléaire conduirait à une irradiation interne des populations par deux voies.

- la voie "inhalation" qui concerne les personnes respirant l'air du panache pendant son passage

- la voie "ingestion" dont le vecteur essentiel est la consommation de produits laitiers frais contaminés pouvant concerner des populations autres que celles présentes sous le panache.

Ainsi, un rejet de 1 Ci d'iode <sup>131</sup>I, réparti sur 1 heure, peut induire, à courte distance de l'installation, une irradiation de la thyroïde du nourrisson de 10 mrem par la voie inhalation et 2000 mrem par la voie ingestion.

Compte tenu de l'importance de ces irradiations, et de celle de la quantité d'iode susceptible d'être rejetée en cas d'accident en l'absence de dispositifs d'épuration, de tels dispositifs sont indispensables.

Leur efficacité doit être effective et permanente, ce qui impose, pour s'en assurer, des essais réels périodiques dans des conditions d'utilisation analogues à celles d'un accident. C'est pourquoi il est imposé d'effectuer des tests in situ jugés représentatifs de l'efficacité de ces dispositifs.

3. - METHODE DE TEST UTILISEE

La méthode consiste en :

- une injection d'iode <sup>127</sup>I stable tracé à l'iode <sup>131</sup>I dans les circuits dont les pièges sont à tester

- deux prélèvements pendant le temps de cette injection ; l'un de ces prélèvements est effectué en amont du piège à iode, l'autre en aval ; l'iode contenu

est retenu sur des charbons de prélèvement

- une mesure des quantités d'iode ainsi recueillies

Le rapport des concentrations moyennes des prélèvements amont et aval donne une estimation de l'efficacité moyenne du piège pendant l'essai.

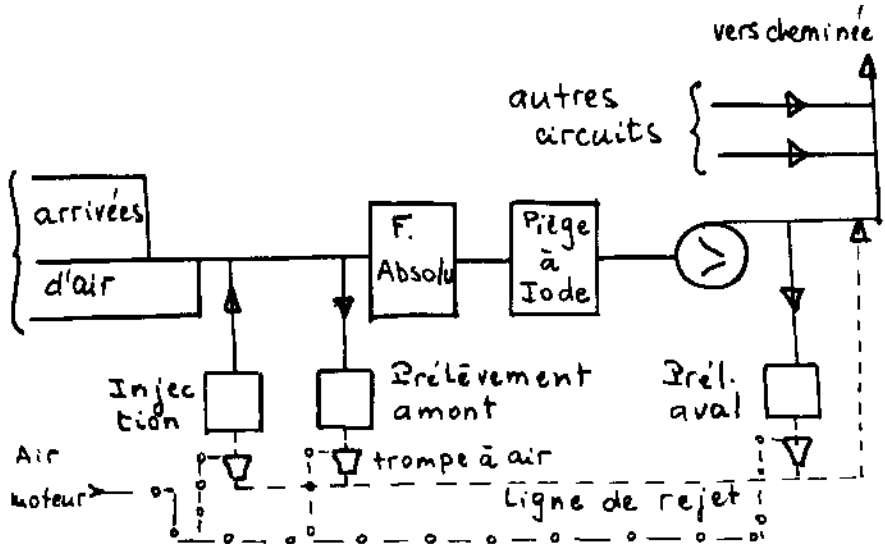

De nombreux paramètres physiques (humidité relative, température, vitesse de passage, temps de contact) ayant une influence importante sur l'efficacité des pièges à iode, il convient que ces paramètres aient, au cours de l'essai, une valeur voisine de celle qu'ils auraient en cas d'accident.

#### 4. - APPLICATION PRATIQUE

Du principe même de la méthode, il découle la nécessité des dispositifs ci-après :

##### 4.1. Dispositif d'injection

Ce dispositif est constitué de deux prises, l'une destinée à l'injection d'iode  $^{127}$ , dont la concentration dans le fluide est représentative de la concentration qu'il y aurait en iode  $^{131}$  lors d'un accident réel, l'autre destinée à l'injection d'iode  $^{131}$  utilisé en traceur radioactif.

Le dispositif d'injection doit être implanté de manière à respecter les critères suivants :

- obtention d'une bonne homogénéisation fluide-iode au droit du prélèvement amont et dans le piège
- facilité de raccordement sur le générateur d'iode utilisé par l'expérimentateur (utilisation d'un type normalisé de piquage mis en place sur un tronçon de gaine facilement accessible).



#### 4.2. Dispositif de prélèvement amont

L'échantillon recueilli à travers ce dispositif doit être représentatif du fluide incident sur le piège ; l'implantation doit donc être telle que :

- il n'y ait ni dilution, ni perte d'iode entre le prélèvement et le piège à tester
- l'écoulement ne soit pas perturbé de façon à ne pas prélever dans une "zone morte"
- le point de prélèvement soit d'un accès facile et muni d'un raccord de type normalisé.

Ces considérations conduisent à choisir si possible des points de prélèvement situés très près du piège à iode à tester.

#### 4.3. Dispositif de prélèvement aval

A travers ce dispositif, il faut recueillir un échantillon représentatif de l'ensemble de la veine fluide ayant traversé le filtre, notamment lorsqu'il est constitué de plusieurs éléments filtrants, ce qui est généralement le cas.

Le point de prélèvement aval doit donc :

- être tel qu'il n'y ait pas de dilution entre la sortie des pièges et le point de prélèvement
- être situé suffisamment loin de l'ensemble filtrant afin de laisser aux veines fluides ayant traversé les différents éléments filtrants un parcours suffisant pour l'obtention d'un mélange satisfaisant
- être facilement accessible et muni d'un raccord de type normalisé.

Ces remarques conduisent fréquemment au choix d'une implantation au refoulement des ventilateurs d'extraction.

#### 4.4. Rejets

Il est nécessaire, pour des raisons de sûreté, de maintenir la source d'iode en dépression ; de ce fait, elle est soumise à une extraction d'air qui présente un risque de contamination.

D'autre part, les prélèvements amont et aval sont épurés de l'iode qu'ils contiennent par les charbons de prélèvements, mais ne doivent pas être rejetés dans les locaux en raison des aérosols et gaz rares qu'ils peuvent contenir.

Les circuits à tester doivent donc être équipés de points de rejets qui, ne devant pas perturber les injections ou les prélèvements, sont choisis en aval du circuit testé.

### 5. - DESCRIPTION SOMMAIRE DU MATERIEL

#### 5.1. Source d'iode

L'ensemble générateur d'iode est contenu dans une boîte hermétique maintenue en dépression. La génération se fait par passage d'air sur des paillettes. Par réaction chimique préalable, l'opérateur peut générer de l'iode moléculaire (I<sub>2</sub>) ou de l'iodure de méthyle (ICH<sub>3</sub>)

## 5.2. Prélèvements

Les lignes de prélèvement comprennent un charbon de prélèvement, un compteur volumétrique, un robinet de réglage et une trompe à air.

## 6. - PROCEDURE PRATIQUE

Le schéma d'enclenchement d'un essai in situ est alors le suivant :

- mise en service du piège à iode et stabilisation au régime nominal
- mise en service de l'injection et des prélèvements
- recueil des charbons de prélèvement et comptage

## 7. - RESULTATS OBTENUS A E.D.F.

Les valeurs des efficacités vis-à-vis de ICH.3 observées lors des derniers essais in situ réalisés à E.D.F. figurent dans le tableau ci-après :

Centrale	Type de réacteur	Circuit	Efficacité
BUGEY	Graphite Gaz	Vidange réacteur (piège n°2)	4 900
ST.LAURENT 1	Graphite Gaz	Vidange réacteur (piège n°2)	770
ST.LAURENT 2	Graphite Gaz	Vidange réacteur (piège n°1)	200
CHINON 2	Graphite Gaz	Vidange réacteur (piège Sud)	250
CHINON 3	Graphite Gaz	Vidange réacteur	460
CHOOZ	Pressurisé	Ventilation de la caverne des auxiliaires	300
FESSEMEIL	Pressurisé	Ventilation du bâtiment des auxiliaires	150
		Ventilation du bâtiment de combustible 1	110
		Ventilation du bâtiment de combustible 2	
		Ventilation des périphériques 1	
		Ventilation des périphériques 2	

## 8. - CONCLUSION

La mise en œuvre de ces essais est souvent délicate pour le premier test d'un circuit donné. (choix des emplacements, obtention des conditions nominales de fonctionnement, calcul de la quantité d'iode I31 à injecter).

Néanmoins, quand l'essai est au point, il permet une estimation satisfaisante de l'efficacité du dispositif d'épuration.

Sa périodicité annuelle permet de détecter les vieillissements inévitables des pièges, et leur remplacement en temps utile.

PRODUCTION AND EMISSION OF CARBON-14 FROM NUCLEAR POWER STATIONS  
AND REPROCESSING PLANTS AND ITS RADIOECOLOGICAL SIGNIFICANCE

H. Bonka, K. Brüssermann, G. Schwarz, U. Willrodt

Professorial Chair for Reactor Technology  
Rheinisch-Westfälische Technische Hochschule Aachen

1. INTRODUCTION

up to 4 years ago C 14 was not recognized as a radionuclide with consequences within the nuclear fuel cycle (1), (2), (3), (4). New investigations have shown that the radiation exposure from this isotope is not negligible when compared to the other emissions from nuclear facilities.

2. PRODUCTION OF C 14 IN NUCLEAR POWER REACTORS AND EMISSION FROM NUCLEAR FACILITIES

In nuclear power reactors C 14 is mainly produced due to (n,  $\gamma$ )-reactions with C 13, (n, p)-reactions with N 14 and ( $\gamma$ ,  $\alpha$ )-reactions with O 17. Other possible reactions with their threshold energies are illustrated in Fig. 1 (1). The most important nuclides out of which C 14 is produced are present in the reactor-materials and in the atmosphere around the reactor pressure vessel.

The C 14 production, due to the C-, N- and O-impurities listed in Tab. 1, the oxygen content of the coolant and of the air around the reactor pressure vessel in Light Water Reactors (LWR) and the carbon of the graphite moderator in High Temperature Reactors (HTR), is estimated in the affected parts of the facilities. The results for plants with 1000 MW<sub>e</sub> full load capacity are shown in Tab. 2. In contrast to reference (2) these new estimations for Liquid Metal Fast Breeder Reactors (LMFBR) are based on the assumption that the sodium layer between reactor core and reactor tank is greater in this reactor type. Furthermore a C 14-production by ternary fission seems to be possible (5), although an estimation of this content is nowadays very difficult because of the uncertain fission yields. A rough estimation indicates the values listed in Tab. 2. As can be seen from this table the main production of C 14 is caused by the N-impurities in the fuel and the graphite, and by the oxygen in the water and the fuel-elements.

The emissions from nuclear facilities are estimated assuming that the C 14 in the coolant of the reactor, and the C 14 entering the reprocessing plant (RP) during the leaching of the fuel elements is totally emitted from the respective facility especially as the chemical form of CO<sub>2</sub> via the stack of a HTR-reprocessing plant with assumed grind-burn-leach head-end. The emission data of LWR and RP for LWR-fuel elements are verified in the meantime by several measurements (6), (7), (8), (9). It is interesting that C 14 of BWR (6) and RP (9) is found as CO<sub>2</sub> in the waste air, whereas hydrocarbons such as CH<sub>4</sub> and C<sub>2</sub>H<sub>6</sub> are mainly found in PWR (7), (8). The waste water emission from LWR seems to be about 1% of the total C 14 release (10), (11).

### 3. RADIATION EXPOSURE DUE TO C 14 FROM NUCLEAR FACILITIES

The radiological significance of C 14 can be seen from Tabs. 3 and 4, where the radiation exposure of this nuclide is compared to that of other isotopes. These values are estimated with the emission data of Tabs. 5 and 6 and are valid for the maximum concentration in air, Fig. 2. To assess the exposure in a conservative manner, the contaminated foodstuffs are stipulated to be produced at the specific site, C 14 being in the chemical form of CO<sub>2</sub>. By means of a specific activity model the dose conversion factor for the ingestion of this isotope is assessed at 42 rem m<sup>3</sup>/Ci s for the total body, the dose of the natural content of C 14 in the total body being 1.41 mrem/a with a corresponding CO<sub>2</sub> air concentration of 325 ppm. The results indicate that C 14 is the most important radionuclide for the total body radiation exposure in the vicinity of LWR. It is also significant for RP, especially those for HTR-fuel-elements with grind-burn-leach head-end. Therefore it seems to be doubtful if it is possible to allow a release of the total C 14 O<sub>2</sub> from a large re-processing plant for HTR-fuel elements in the future. Many problems will also arise in connection with the reprocessing of nitride fuel elements (12) for LMFBR, in which the production rate will be about 10<sup>4</sup> Ci/a for 1000 MW<sub>e</sub> installed power capacity.

The collective dose is important as a further criterion for the radiological significance of C 14, the dose for the first pass exposure being about 1000 man-rem with a stipulated emission of 500 Ci and present population density. The contribution of the same amount of globally distributed C 14 to the collective dose depends on the integration time - see Fig. 3 - and will be about 2 · 10<sup>5</sup> man-rem for a stipulated population of 1 · 10<sup>10</sup> human beings. Regarding the total body the collective dose by C 14-emissions as shown in Tab. 6 will be of more significance than those of all other nuclides (13).

The meaning of globally distributed C 14 for the collective dose is also illustrated by the future radiation exposure, see Fig. 4, which is estimated with a prognosis of the installed nuclear power capacity according to reference (14). About two thirds of this future dose is caused by emissions from HTR-RP, a total release of C 14 being stipulated. If it is possible to retain about 80% of this isotope in RP and to finally store this amount, the dose due to globally distributed C 14 will be in acceptable limits.

### 4. SUMMARY

In nuclear power reactors with 1000 MW<sub>e</sub> full load capacity C 14 will be produced at rates of 10 to 100 Ci/a according to the reactor type. The yearly emission rate for LWR is assessed at 10 Ci, for HTR at 0.1 Ci and for LMFBR at 1 Ci. The corresponding RP for 40,000 MW<sub>e</sub> installed nuclear reactor capacity may release about 500, 3000 and 100 Ci/a according to the nitrogen impurities in the fuel elements and the coolant of the reactor type. This C 14 will significantly influence the radiation exposure of the population.

The present work was sponsored by the Federal Ministry of the Interior.

## REFERENCES

- (1) Bonka, H., Schwarz, G., Kippe, H.-B. "Contamination of the environment by carbon-14 produced in high temperature reactors" Kerntechnik 15 No. 7 (1973) 297
- (2) Bonka, H., Brüssermann, K., Schwarz, G. "Umweltbelastung durch Radiokohlenstoff aus kerntechnischen Anlagen", Reaktortagung, Berlin (April 1974) 454
- (3) Pohl, R. O. "Nuclear Energy: Health impact of carbon-14" Laboratory of Atomic and Solid State Physics, Cornell University, Ithaca, New York (1975)
- (4) Fowler, T. W. et al. "Public health considerations of carbon-14 discharges from the light-water-cooled nuclear power reactor industry" USEPA, ORF/TAD-76-5 (1976)
- (5) Andreev, V. N., Nacopakin, V. G., Rogov, V. I. "Long-range particles with  $^{14}\text{C}$  in ternary fission of  $^{235}\text{U}$  by thermal neutrons", Sov. J. Nucl. Phys. 8, No. 1 (1969)
- (6) Kunz, C. O., Mahoney, W. E., Miller, T. W. " $^{14}\text{C}$  gaseous effluents from boiling water reactors", ANS Meeting, New Orleans (June 1975)
- (7) Kunz, C. O., Mahoney, W. E., Miller, T. W. " $^{14}\text{C}$  gaseous effluents from pressurized water reactors", 8. Midyear Topical Symposium, Knoxville, CONF-741018 (Okt. 1974)
- (8) Schwibach, J., Riedel, H., Institut für Strahlenhygiene des Bundesgesundheitsamtes Neuherberg (private communication)
- (9) Schüttekopf, H., Kernforschungszentrum Karlsruhe (private communication)
- (10) Kahn, B., Krieger, H. L., Gold, H. E. "Radionuclide release at a BWR nuclear power station", Transactions of the American Nuclear Society, Boston 14, No. 1 (1971) 326
- (11) Gans, I., Institut für Wasser-, Boden- und Luft hygiene des Bundesgesundheitsamtes, Berlin (West), (private communication)
- (12) Giacchetti, G., Sari, G., Walker, C. T. "Actinides and fission products distribution in Fast Breeder nitride fuel" Nuclear Technology 28 (1976) 216
- (13) Bonka, H. et al. "Limitation of radioactive emissions from reprocessing plants", 4. IRPA congress Paris (1977) 280
- (14) Bonka, H. et al. "Zukünftige radioaktive Umweltbelastung in der Bundesrepublik Deutschland durch Radionuklide aus kerntechnischen Anlagen im Normalbetrieb", Jül 1220 (1975)

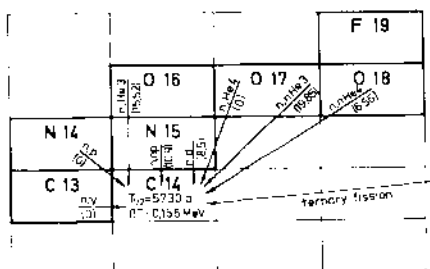

Fig 1 Neutron reactions leading to C-14 with the threshold energies in MeV

Reactor type	Impurities [ppm] or [vol.]										
	Coolant			Fuel			Fuel elements				
	C	N	O	C	N	O	C	N	O	O	
BWR	5	-	-	50	6	-	770	80	1500	-	-
PWR	5	-	-	50	6	-	770	80	1500	-	-
HTGR	CC 3 ppm CO 1 ppm O 4.0%	-	-	CC 3 ppm CO 1 ppm O 4.0%	50	6	-	-	5	-	-
LMFBR	20	1	-	50	6	-	1000	1000	30	-	-

Tab. 1 C, N and O-impurities used to calculate the rate of C-14 production in the different nuclear reactor types  
1) Graphite  
2) In the volume of voids similar impurities as in the coolant

Specification	Reactor type						
	BWR	PWR	HTR	LMFBR			
Core surface area (m <sup>2</sup> )	51.4	51.3	4.3	-			
Core volume (m <sup>3</sup> )	4.8E-7	4.8E-7	5.4E-7	1.2E-6			
Coolant	H <sub>2</sub> O	H <sub>2</sub> O	NaK	NaK			
Core pressure (MPa)	16	16	16	16			
Fuel element	Cladding	Fuel	Uranium	Uranium	Uranium	Uranium	
			Enrichment (%)	3.5	3.5	3.5	3.5
			Length (cm)	387	387	387	387
			Outer diameter (cm)	2.5	2.5	2.5	2.5
			Inner diameter (cm)	1.9	1.9	1.9	1.9
Release from reactor	100	100	100	100			
Released from reprocessing plant	100	100	100	100			
Stored with cladding	100	100	100	100			

Tab 2. Yearly production of Cl<sup>136</sup> in different reactor types (1000 MW<sub>e</sub>, full load) and emission rates of nuclear power plants and reprocessing plants.

Organ	Radiation exposure [mrem/a]							
	Nuclear power plant				Reprocessing plant			
	BWR	PWR	HTR	LMFBR	LWR	HTR	LMFBR	
Total dose	0.14	0.15	0.22	0.04	3.2	13.6	1.3	
St. 1	0.17	0.18	0.25	0.12	7.8	21.1	3.7	
St. 2	5.8	3.5	0.04	0.1	50.2	63.8	41.3	
St. 3	0.14	0.15	0.02	0.04	4.1	14.1	4.1	
St. 4	0.58	0.17	0.02	0.04	5.2	15.8	4.6	

Tab 3. Maximum possible radiation exposure due to gaseous releases from nuclear power plants (1000 MW<sub>e</sub>) and reprocessing plants (40000 MW<sub>e</sub>) full load in the maximum of the concentration. Emission height: Nuclear power plant: 100 m, X=3E-1 s/m<sup>2</sup>; Reprocessing plant: 200 m, X=1E-7 s/m<sup>2</sup>.

Nuclide	Release rates [Ci/a]			
	BWR	PWR	HTR	LMFBR
H-3	30	20	10	1
C-14	10	10	10	1
K-85	700	700	20	1000
Kr-88	30	50	80	50
Sr-89	1E-3	1E-3	-	-
Sr-90	1E-4	1E-4	3E-4	9E-3
I-131	10	10	3E-4	9E-3
Xe-133	2500	2500	50	7000
Cs-134	1E-4	1E-4	-	-
Cs-137	2E-4	2E-4	-	-
α-rays	1E-5	1E-5	-	1E-5

Tab 5: Expected radioactive effluents from a nuclear power plant (1000 MW<sub>e</sub>) to the atmosphere.

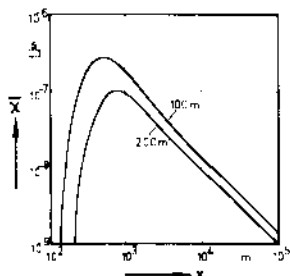

Fig 2. Average long time diffusion factor X near ground level in the main wind direction near Frankfurt for a release height of 100m and 200m.

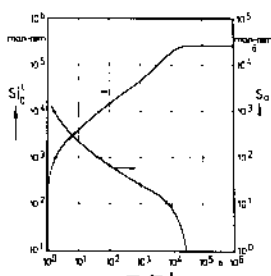

Fig 3. Collective dose S<sub>0</sub> dependence of integration time S<sub>0</sub><sup>1</sup> and yearly collective dose S<sub>0</sub> by a release of 500 Ci Cl<sup>136</sup> (World population 10<sup>9</sup>).

Nuclide	Release rates [Ci/a]		
	LWR	HTR	LMFBR
H-3	3E4	6E4	1E5
C-14	5E2	3E3	1E2
Kr-85	2E6	2E6	5E3
Sr-89	0.1	0.1	0.1
Sr-90	0.1	0.1	0.1
I-131	0.2	0.2	0.16
Xe-133	1E6	1E6	1E6
Cs-134	0.1	0.1	0.1
Cs-137	0.1	0.1	0.1
Pu-238	0.03	0.028	0.053
Pu-239	0.005	2E-5	0.017
Pu-240	0.002	5E-5	0.02
Am-241	0.001	2E-5	0.01
Cm-243	0.01	0.005	0.018
Cm-244	0.012	0.005	0.006

Tab 6: Expected radioactive effluents from reprocessing plants (40000 MW<sub>e</sub>) full load. H-3 and Kr-85 retention 90%, iodine retention 99.5%. Decay time: 200a.

Nuclide	Organ	Exposure pathway	Radiation exposure [mrem/a]							
			Nuclear power plant				Reprocessing plant			
			BWR	PWR	HTR	LMFBR	LWR	HTR	LMFBR	
H-3	T-Body	Inh	8E-6	3E-6	1E-5	1E-5	0.02	0.26	0.16	
H-3	T-Body	Ing	8E-6	3E-6	1E-5	1E-5	0.02	0.26	0.16	
C-14	Skin	Inh	5E-5	5E-5	5E-5	5E-5	0.01	0.01	0.01	
C-14	T-Body	Ing	0.18	0.18	0.18	0.18	2.1	12.6	0.42	
Kr-85	T-Body	Inh	7E-5	7E-5	7E-5	7E-5	0.04	0.07	0.02	
Kr-85	Skin	Inh	8E-3	8E-3	8E-3	8E-3	0.01	0.01	0.01	
Kr-85	T-Body	Ing	4E-3	7E-3	0.1	7E-3	0.01	0.01	0.01	
Kr-85	Skin	Inh	7E-4	1E-3	2E-3	7E-4	0.01	0.01	0.01	
Sr-89	Bone	Inh	3E-6	3E-6	3E-6	3E-6	9E-6	9E-5	9E-5	
Sr-89	Bone	Ing	3E-6	3E-6	3E-6	3E-6	0.02	0.02	0.02	
Sr-90	Bone	Inh	9E-5	9E-5	9E-5	9E-5	0.03	0.03	0.03	
Sr-90	Bone	Ing	5E-3	5E-3	5E-3	5E-3	1.5	1.5	1.5	
Xe-133	Skin	Inh	0.02	0.02	3E-4	0.06	0.06	0.06		
Xe-133	T-Body	Inh	9E-3	9E-3	9E-3	9E-3	0.03	0.03	0.03	
I-129	Thyroid	Inh	-	-	-	-	0.02	0.02	0.01	
I-129	Thyroid	Ing	0.03	0.01	9E-5	3E-3	0.02	0.01	0.02	
I-131	Thyroid	Inh	6.6	3.3	0.02	0.6	7.0	3.5	3.9	
I-131	Thyroid	Ing	6.5	6E-7	-	-	2E-4	2E-4	2E-4	
Cs-134	T-Body	Ing	1E-4	1E-4	-	-	0.03	0.03	0.03	
Cs-137	T-Body	Inh	7E-7	7E-7	-	-	1E-4	1E-4	1E-4	
Cs-137	T-Body	Ing	1E-4	1E-4	-	-	0.02	0.02	0.02	
Pu-238	Lung	Inh	4E-5	4E-5	-	-	9E-5	0.3	0.56	
Pu-238	Bone	Inh	4E-5	4E-5	-	-	9E-5	0.2	0.4	
Pu-239	Lung	Inh	5E-6	5E-6	-	-	2E-5	0.03	0.4	
Pu-239	Bone	Inh	5E-6	5E-6	-	-	2E-5	0.03	0.4	
Pu-240	Lung	Inh	7E-6	7E-6	-	-	2E-5	0.04	0.35	
Pu-240	Bone	Inh	8E-6	8E-6	-	-	2E-5	0.04	0.4	
Am-241	Lung	Inh	2E-6	2E-6	-	-	0.02	0.02	0.19	
Am-241	Bone	Inh	1E-6	1E-6	-	-	5E-6	0.1	0.1	
Cm-242	Lung	Inh	1E-6	1E-6	-	-	1E-4	0.35	0.3	
Cm-242	Bone	Inh	5E-6	5E-6	-	-	5E-6	0.01	0.4	
Cm-244	Lung	Inh	4E-6	4E-6	-	-	0.02	0.05	0.11	
Cm-244	Bone	Inh	3E-5	3E-5	-	-	0.18	0.04	0.09	

Tab 7. Maximum possible radiation exposure due to gaseous releases from nuclear power plants (1000 MW<sub>e</sub>) and reprocessing plants (40000 MW<sub>e</sub>) full load in the maximum of the concentration.

Emission height: Nuclear power plant - 100 m, X=3E-1 s/m<sup>2</sup>; Reprocessing plant - 200 m, X=1E-7 s/m<sup>2</sup>.

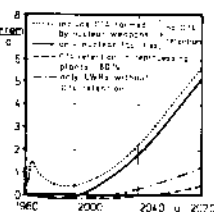

Fig 4. Expected radiation exposure of the total body in the northern hemisphere due to globally distributed Cl<sup>136</sup> from nuclear power plants, reprocessing plants and nuclear effluents during the increase in Cl<sup>136</sup> concentration.

## GLOBAL IMPACT OF CARBON-14 FROM NUCLEAR POWER REACTORS

A. A. Moghissi and M. W. Carter

Georgia Institute of Technology  
Office of Interdisciplinary Programs  
Atlanta, GA 30332

## 1. INTRODUCTION

Although the importance of carbon-14 as an environmental pollutant was clearly recognized during the time of atmospheric weapons testing, its significance as a potential contributor to the population dose resulting from releases from nuclear power reactors has been recognized only recently. Because of certain differences between the environmental behavior of carbon-14 produced by nuclear detonations and that from nuclear power reactors, the available information on weapons-produced carbon-14 is not necessarily directly applicable to certain considerations of carbon-14 from reactors. Unfortunately a large number of papers dealing with carbon-14 produced by power reactors were based on somewhat speculative values caused by the lack of measured data.

A review by Kelly, et al. (1) summarizes the available data. The estimates for production rates from reactors deviate by two orders of magnitude. These differences are not solely based on the nature of the reactors but also on the lack of measured data. In a recent paper, Pohl (2) has made an assessment of the health impact of carbon-14. Although the paper has not been published it has been used in various hearings in the U.S.

## 2. PRODUCTION OF CARBON-14

The major carbon-14 producing nuclear reactions in the nuclear power reactors, along with their respective cross sections, are as follows:

N-14 (n, p) C-14	1.8 b
O-17 (n, α) C-14	0.235 b
C-13 (n, γ) C-14	0.09 mb
N-15 (n, d) C-14	$2.5 \times 10^{-7}$ b
O-16 (n, He-3) C-14	$5 \times 10^{-8}$ b
U-235 (n, f)	$< 10^{-10}$ b
Pu-239 (n, f)	$< 10^{-10}$ b

In light water reactors the first two reactions are dominant, whereas in graphite moderated reactors the third reaction should also be considered.

Carbon-14 production in fuel is dominated by its nitrogen content. Industry accepted values for the maximum allowable nitrogen content of fuel is about 200 ppm. Routine measurements of nitrogen are limited to compliance with this limit (1). Due to the essentially unknown nature of the nitrogen content of the fuel, cladding and other materials subject to neutron irradiation, the pertinent calculations in the following discussion are based on a nitrogen value of 100 ppm. It is the authors' judgment that this value is probably too high and represents the upper limit of probable values. If, in the future, lower values are found to be more appropriate the predicted global burdens can be reduced accordingly.

The following data are normalized for the production, in Ci per giga watt (electric) per year (GWEA):

	PWR	BWR	HTGR
Fuel and cladding, Ci/GWEA	75	87	600
Coolant and moderator, Ci/GWEA	15	15	
Fuel irradiation, kWA/gM	37	33	95
Efficiency (elec./therm), %	33	33	38

There are additional sources of carbon-14 relative to the operation of the PWR. This reactor type occasionally uses hydrazine during certain phases of operation, resulting in carbon-14 production in addition to the values reported above. This practice is gradually being discontinued and hopefully will be stopped.

The production of carbon-14 from heavy water reactors is somewhat similar to that of HTGR. The production values depend upon the filling of annulus which is generally either nitrogen or carbon dioxide. As expected carbon-14 production is considerably higher if nitrogen is used. In the following discussion carbon-14 production of heavy water reactors is assumed to be similar to that of HTGR. The lack of adequate information for this type of reactor is particularly unfortunate because it is expected that it will find increased popularity in the future.

### 3. ATMOSPHERIC CONCENTRATION OF CARBON-14

Due to the large inventories of carbon-14 and carbon in the atmosphere, it has become customary to express the environmental burden of carbon-14 in terms of pCi/gC. The specific activity of "modern carbon" is estimated to be  $6.13 \pm 0.03$  pCi/gC (4). The atmospheric weapons testing added 6-10 MCi carbon-14 to the atmosphere (4). The average annual production rate is about 0.03 MCi. These values are useful because they show the magnitude of the carbon-14 production from nuclear power reactors as compared to its natural production.

The natural equilibrium of carbon-14 has been disturbed by the combustion of fossil fuels. The so-called "Suess effect" has diluted the carbon-14 of the atmosphere and will continue this process in the future.

The carbon content of the atmosphere prior to the Suess period was about  $0.6 \times 10^{18}$  g (5). This, along with the previously reported value of 6.1 pCi/gC, results in an atmospheric equilibrium value of 3.7 MCi. The total global inventory is considerably higher, although most of it is dissolved in the upper layer of the oceans.

### 4. PROJECTED CONCENTRATIONS OF CARBON-14

From the foregoing, it becomes evident that a prediction of carbon-14 concentrations must consider the production of carbon-14 as well as that of carbon-12. A prediction for the combustion of fossil fuel is therefore necessary in order to evaluate the environmental impact of carbon-14. According to Rotty (6) in 1974 the production of carbon dioxide from sources other than fossil fuel combustion constituted less than 5% of the total carbon dioxide production. This proportion should be valid for the foreseeable future. This fraction will be neglected because uncertainties associated with other factors far exceed the uncertainty in this term.

The projection of energy production is based on an increase of 3.5% per year as predicted by Machta (5). The contribution of nuclear energy is assumed



to be about 25% by the year 2000. This is identical to the projections used by Magno, et al. (7). It is our belief that a slower energy production growth rate in the U.S., Western Europe and Japan will be more than offset by the increased requirements of other countries. We have also used Machta's model to predict the removal of carbon dioxide from the atmosphere. We have, however, disregarded the deep ocean and the biosphere because of their minor contribution to the removal of carbon dioxide. Based on these assumptions it is estimated that by the year 2000 the electrical energy production from nuclear reactors will be 3,060 GWE and will increase to about 10,000 GWE by the year 2020. Cumulative discharge of carbon-14 would be about 7 MCi by the year 2000 and about 40 MCi by 2020. These values correspond to concentrations above the background of 4.2 pCi/gC by the year 2000 and 16.5 pCi/gC by 2020, based on a nitrogen content of 100 ppm in the fuel.

#### 5. ENVIRONMENTAL IMPACT OF CARBON-14 RELEASE

The values calculated above are considerably above values reported by others. The reactor release data obtained by Kahn, et al. (8) and others (1) are clearly in the order of 10-20 Ci/GWEA. Although the assumption of 100 ppm of nitrogen is probably too high, it can not explain the difference between the measured and predicted values. Much more probable is the possibility that in light water reactors that portion of carbon-14 which is produced in the coolant is released whereas the fraction produced in the fuel remains in the fuel structure and is released during the fuel reprocessing. If this hypothesis proves to be correct, carbon-14 becomes much like krypton-85 in that remedial actions could be applied only at fuel reprocessing plants. One should consider that a reduction by one order of magnitude of the global burden would be quite easily achieved by requirements which are probably easily achieved in fuel reprocessing plants. The only exceptions to the above consideration are the heavy water reactors. It is probable that recovery systems for those reactors must be installed at the reactor site.

Another subject of considerable interest is the local dose caused by carbon-14 release. Scattered measurements indicate that PWR releases are predominantly in the form of methane and ethane. Because the adsorption of these compounds by the biosphere is small, they must be oxidized before they would have a significant impact on the local environment. The oxidation of methane occurs, however, with a half time of more than one year (9), and thus is too slow to permit any local impact. Releases from BWR are predominantly in the form of carbon oxides. Any local carbon-14 problems around BWR's will be influenced by the presence of carbon which may result from combustion of fossil fuels. Therefore, it may be advisable to place a fossil power plant downstream from a nuclear power plant. This application of Suess effect would be also useful for other nuclear installations.

This rather simple principle is certainly not universally recognized. Pohl (2) apparently disregards the importance of the specific activity concept. Although carbon dioxide production may have deleterious effects on climate or other environmental parameters, it is clearly beneficial to the mitigation of effects from the production of carbon-14.

#### 6. POPULATION DOSE

The dosimetry assumes an equal specific activity in the atmosphere and the biosphere including humans. The following equation may be used to calculate the dose, H, in mrem/year:

$$H = 0.93 F \cdot C$$

F is the fraction of carbon in the body or the organ of reference and C is the specific activity in pCi/gC. Based on this equation, the total body dose of carbon-14 by the year 2000 would be 0.7 mrem/year above the natural background and would increase to 2.8 mrem above that level by the year 2020. These levels would be about 0.1 and 0.4 respectively, if carbon-14 were effectively collected at fuel reprocessing plants.

The purpose of this discussion has been to indicate trends in the production of carbon-14 and to estimate the associated population dose. Corrective measures are suggested which could be effective in reducing the population dose. Clearly, additional data are needed which hopefully will indicate a smaller dose to the population than indicated in this paper. The authors realize that the assumptions used to calculate projected environmental impact of carbon-14 release may be overly conservative.

#### REFERENCES

- (1) KELLY, G. N., JONES, J. A., BRYANT, P. M., MORLEY, F., "The Predicted Radiation Exposure of the Population of the European Community Resulting from Discharges of Krypton-85, Tritium, Carbon-14 and Iodine-129 from the Nuclear Power Industry to the Year 2000," DOC.V/2676/75, Luxembourg (1975).
- (2) POHL, R. O., "Health Impact of Carbon-14," submitted to Nuclear Regulatory Commission.
- (3) American Society for Testing Materials Annual Book of ASTM Standards, part 45, "Nuclear Materials" (1975).
- (4) United Nations Scientific Committee on the Effects of Atomic Radiation, United Nations (1972).
- (5) MACHITA, L., in Carbon and the Biosphere, U.S. Atomic Energy Commission (Conf-720510) (1973) pp. 21-31.
- (6) ROTTY, R. M., "Global Carbon Dioxide Production from Fossil Fuels and Cement," Institute for Energy Analysis, Oak Ridge, TN (1976).
- (7) MAGNO, P. J., NELSON, C. B., ELLET, W. H., Proceedings of the 13th Air Cleaning Conference, San Francisco, CA (1974).
- (8) KAIN, B., et al., "Radiological Surveillance Studies at a Pressurized Water Nuclear Power Reactor," Report RD 71-1, U.S. Environmental Protection Agency, Washington, D.C. (1971).
- (9) WOFSEY, S. C., in Annual Review of Earth and Planetary Sciences, Annual Reviews, Palo Alto, CA (1976) pp. 441-469.

A PRACTICAL GUIDE FOR RADIOLOGICAL SURVEILLANCE OF THE ENVIRONMENTAT FEDERALLY-OWNED NUCLEAR SITES IN THE USA

JP CORLEY and DA WAITE

BATELLE

Pacific Northwest Laboratories

RICHLAND, WASHINGTON 99352

DR ELLE

Division of Safety, Standard and Compliance

U.S. Energy Research and Development Administration

WASHINGTON, DC 20555

The variety, complexity, and staff resources of nuclear facilities operated for the U.S. Energy Research and Development Administration (USERDA) made a completely uniform environmental surveillance program both unwarranted and unwise. Some commonality of treatment of common surveillance problems is required for comparable evaluations of site management and adequate public information. The USERDA Division of Safety, Standards and Compliance has sponsored the preparation of an Environmental Surveillance Guide to achieve this purpose.

Key features of the Guide include the following :

1. Environmental pathway analysis, with emphasis on identification and monitoring of critical pathways for population exposure.
2. General program design and performance criteria, including designation of environmental dose levels requiring specific monitoring.
3. Guidance for data analysis and statistical treatment, including values below minimum detectable levels.
4. Guidance on quality assurance for environmental programs.
5. Advices on data display and documentation.
6. A review of U.S. measurement techniques and equipment, with performance criteria and comparisons.

Although the Guide is addressed specifically to USERDA sites, the principles and methods are generally applicable to all nuclear facilities.

This paper is based on work performed under U.S. Energy Research and Development Administration Contract No. AT (45-1)-1830.

CARACTERISTIQUES DES GRANDES REGIONS NATURELLES DE L'IRAN  
EN VUE DE LA MISE EN PLACE D'UN PROGRAMME NUCLEAIRE

N. Rouhanizadeh et Dj. Moghimi  
Institut des sciences et techniques nucléaires  
de l'université de Téhéran - Iran-

INTRODUCTION

Dans un pays comme l'IRAN, décidé dans la prochaine décennie à assurer un important programme de développement industriel, l'immensité des ressources pétrolières ne doit pas faire oublier leur épuisement inéluctable. C'est pourquoi notre pays a décidé de jouer la carte du nucléaire, et ce le plus tôt possible de façon à assurer la relève de ses ressources énergétiques naturelles, tout en évitant de les gaspiller trop vite.

Afin de mettre en place cet important programme nous avons essayé dans cet exposé de résumer les informations nécessaires à la connaissance de notre pays et au choix des sites des centrales nucléaires.

1. CARACTERISTIQUES PHYSIQUES DE L'IRAN

1.1. Géographie

Limité au nord par l'U.R.S.S. et la MER CASPIENNE, au sud par le GOLFE PERSIQUE et la MER D'OMAN, à l'est par l'AFGANISTAN et le PAKISTAN, à l'ouest par l'IRAK et la TURQUIE, L'IRAN possède une superficie de 1 645 000 km<sup>2</sup>.

On peut classer ses différents reliefs en 3 catégories :

-1) Régions montagneuses, composées de 4 chaînes

- chaînes septentrionales
- chaînes occidentales et australes
- chaînes centrales
- chaînes orientales

-2) Plaines intérieures

-3) Montagnes internes et plaines côtières

Rivières

: impropres à la navigation, seule la partie inférieure de la rivière KARUN est navigable par les petits bateaux.

4 régions selon la direction des rivières.

-1) Région Caspienne

Rivières : ARAS - KOLRA - SENID RUD - HARAZE - ATRAK et GORGAN qui convergent vers la mer Caspienne

-2) Région du Golfe Persique et Mer D'Oman

Rivière KARUN grossie de la DEZE et qui rejoint l'ARVAND RUD

-3) Région du lac REZAYEH

TALKHEH - RUD, ZAMENEH - RUD, SIMENEH - RUD, NAZLOU - RUD, et REZAYEH.

-4) Région des lacs et mers intérieures

KARANDJ et DJAJ-RUD, ZAYAN-RUD qui se jette dans le GIOV-KHUNI, KORE et HALIK-RUD.

## -5) Région Orientale et N.E

Petites rivières comme HARI-RUD et BIRMANDE qui alimentent le lac de HAMOUL et d'autres petits lacs (aux frontières de L'AFGANISTAN).

### 1.2. Géotectonique

L'IRAN entre les Alpes et L'HIMALAYA, est situé dans la partie médiane d'une ceinture de plissements aux dimensions immenses puisqu'elle s'étend de L'OCEAN ATLANTIQUE jusqu'à L'OCEAN PACIFIQUE et sépare les plates formes du Nord (ORASIA) et du Sud (GONDOVANA).

M.ECHTECLINE a fait d'importantes recherches géologiques (1968) ; nous rappellerons ici brièvement les résultats principaux :

- 1) Du point de vue géotectonique la partie centrale de L'IRAN est plus active que les deux zones de L'ELBOURZ et du ZAGROS.
- 2) les zones miogéosynclinales de L'ELBOURZ et du ZAGROS forment une cuvette dans laquelle les sédiments maritimes se sont entassés.
- 3) Au point de vue géologique le centre de L'IRAN ressemble pour une grande partie aux montagnes de L'ELBOURZ.
- 4) Les plissements de la période paléozoïque ont été pratiquement instantanés sauf en quelques zones peu étendues.
- 5) Dans la dernière phase du Précambrien et pendant le Paléozoïque L'IRAN tout entier était solidaire de La plate-forme arabe.

### 1.3. Sismologie

L'IRAN est une région au caractère sismique fortement marqué comme le montre l'analyse de l'activité sismique passée de L'IRAN.

Une analyse plus précise durant les 76 dernières années conduit à distinguer quatre grandes régions sismotectoniques : la zone active du ZAGROS, L'IRAN CENTRAL, ELBOURZ et les chaînes de KOPPEH DAGH.

L'examen de la carte sismotectonique mise au point par Monsieur BERBERIAN (Organisation de Géologie de L'IRAN), après des recherches accumulées pendant plus de cinq années, met en évidence des directions de compression N.E-S.W, le sens des mouvements des failles et le mécanisme originel des tremblements de terre ; on y voit aussi les séismes enregistrés dont la magnitude atteint couramment 6 voire 7.

### 1.4. Le Climat

- 1) Cotes australes et Mer Caspienne : climat type méditerranéen.
- 2) Montagnes occidentales : climat tempéré.
- 3) Plateau central : 2 régions aux climats désertique et semi-désertique.

Parmi les facteurs qui déterminent le climat, deux exercent une influence fondamentale en IRAN ; ce sont altitude et direction des plissements montagneux.

#### Température

3 grands groupes de villes selon la température :

- 1) Celles dont la moyenne varie de 9° en hiver à 42° en été au Sud
- 2) Celles dont les moyennes varient de -10° en hiver à 24° en été au bord de la CASPIENNE.

#### Les précipitations

3 régions sont à considérer :

- 1) Région sèche (250 à 300 mm d'eau par an) (Région Sud)
- 2) Région humide (200 à 600 mm) (Région Est et Ouest)
- 3) Région pluvieuse : montagnes du Nord-Ouest et du Sud-Est (300 à 1.000 mm) (Région Nord).

## 2. RESSOURCES NATURELLES ET ACTIVITES HUMAINES

### 2.1. Sources d'énergie

-1) Le Charbon : (époque tertiaire et période jurassique). Son exploitation s'est développée ces dernières années en raison de la demande industrielle.

On prévoit que la consommation annuelle en charbon et en coke pour la sidérurgie atteindra 5 à 7 millions de tonnes en 1981.

- mines de KERMAN dans le Sud-Est qui sont les plus riches réserves.
- mines de SARGROUDE au bord de la route TEHERAN-RACHTE.
- Centres de ZIRAB et GHAHRUD.

### -2) Gaz naturel :

AGHA-DJARI et ses environs constituent le centre le plus important d'exploitation du gaz qui est ensuite traité à la raffinerie de BIDE-BOLANDE (7 millions de m<sup>3</sup>).

-3) Pétrole : La part la plus importante du revenu national. Ressources situées dans les régions montagneuses du ZAGROS près du GOLFE PERSIQUE et à l'intérieur particulièrement aux environs de GOM.

De 60 millions de m<sup>3</sup> par an de brut exploité en 1962, on est passé à 340 en 1973.

Notons le très vaste réseau d'oléoducs destinés au transport du pétrole jusqu'aux raffineries (ADADAN, TEHERAN, KERMANCHAH, MASJED..) et jusqu'aux ports (MAHE, SHAHAR, KHARKH et MEHREGAN).

### 2.2. Ressources minières

- 1) Minerai de fer : au Sud du pays, environ 1.200 millions de tonnes en réserve.
- 2) Minerai de cuivre : on extrait environ 1.000 tonnes par an en 3 régions (Bord Occidental, Bord Oriental, Nord de l'AZERBAIDJAN).
- 3) Autres minerais : 5,5 millions par an de tonnes de Pierre à chaux, 2,5 millions de tonnes de chromite et 220.000 tonnes de minerai de zinc et de plomb.

### 2.3. Ressources en eau

En raison de son implantation géographique, le pays manque naturellement de ressources en eau.

Les barrages : MOHAMMED REZA SHAH, SHABANOU, FARAH, AMIR KABIR, SHAH ABBAS ARASSE, FARAHNAZE, PAHLAVI ...

### 2.4. Industries

- 1) Sidérurgie : Installation d'ARYAMEH à ISFAHAN ; capacité : 600.000 tonnes pour la 1ère tranche, à 2, 5 millions pour la 2ème et 4 millions pour la 3ème.
- 2) Chimie et pétrochimie : production évaluée annuellement à plus de 0,2 millions de tonnes.

- engrais chimiques, à GHIRAZ (9.500 tonnes d'urée et de nitrate d'ammonium).

- industries chimiques à GHAFOUR (5.500 tonnes de soufre, ammoniac, acide sulfurique et phosphorique, phosphate d'ammonium et super-phosphate)

-pétrochimie à KHARK (600 tonnes de soufre, 6.500 barils de gaz liquide par jour) et ABADAN (PVC, soude...)

-3) Biens d'équipement : production d'automobiles (TEHERAN), tracteurs (TABRIZ), machines industrielles et mobilier (TEHERAN, ISFAHAN, tabriz, et MACHAD)

-4) Industries alimentaires : riz, thé, huile, conserves (villes de la MER CASPENNE), sucre (800 000 tonnes par an), produits laitiers, pâtisseries, boissons non alcoolisées...

## 2.5. Economie Rurale

### -1) Activité zootechnique

Environ 19 millions d'hectares de pâturages de qualités différentes

38,5 millions de moutons et de chèvres :

- élevage migrant : moutons et chèvres

- élevage stable : chèvres et moutons

- élevage de vaches (batif ou scientifique)

Autres élevages : chameau, cheval, âne, mule (pour le travail des champs) volailles (élevage traditionnel dans les villages et élevage intensif pour satisfaire la consommation).

### -2) Agriculture

Jusqu'à ces dernières années, la production de l'IRAN était essentiellement agricole : - riz, coton, thé, arbres fruitiers au bord de la CASPIENNE.

- céréales : Est et Ouest du pays

- arbres fruitiers.

Cette activité diminue ces dernières années au profit de l'industrie.

## 2.6 Population

18,9 millions d'habitants en 1966, 33,5 millions en Novembre 1976.

Plus de 48% des habitants vivent dans les villes (TEHERAN 4,4 Millions de personnes).

Densité : 12 Habitants au km<sup>2</sup> en 1966 et 19 Habitants en 1976.

Les régions du Nord et du Centre sont les plus peuplées, la partie Sud est à peu près désertique.

Rapportée à la surface cultivée, la densité de la population atteignait 365 habitants au km<sup>2</sup> en 1976.

## CONCLUSION

L'IRAN est, un pays riche sur le plan des ressources du sous-sol beaucoup plus que sur le plan des richesses du sol qui ne se prêtent guère qu'à l'élevage et à une agriculture modeste.

Les richesses naturelles donc l'implantation humaine et les besoins énergétiques sont diversifiés ; certaines régions possèdent une main d'oeuvre abondante de toute qualification et des besoins importants en énergie qui justifient la production d'énergie électrique produite entre autres par des centrales nucléaires.

Le choix du site prend une importance considérable : nous espérons, dans cet exposé, avoir rassemblé les informations de base utiles à ces études de site.

INTERET DE L'ASSOCIATION DES METHODES PHYSIQUES  
ET BIOLOGIQUES POUR L'EVALUATION DE LA DOSE ET  
DE SA REPARTITION DANS LES CAS D'IRRADIATION  
GLOBALE AIGUË ACCIDENTELLE

H. Jammet \* \*\*\* E. Strambi \*\* R. Gongora \* J.C. Nénot \*\*\*

## 1. INTRODUCTION

Lors d'irradiation accidentelle, il est nécessaire pour établir le pronostic et pour poser les indications thérapeutiques de connaître la dose et sa répartition. En effet, le pronostic et les indications thérapeutiques sont très différents selon le niveau de dose et le caractère homogène ou hétérogène de la répartition.

L'accident est par définition imprévisible et contrairement aux irradiations thérapeutiques pour lesquelles les paramètres physiques, géométriques, chronologiques de l'irradiation sont préétablis et parfaitement contrôlés, ces paramètres sont aléatoires dans les cas d'irradiation accidentelle. Généralement les caractères d'émission (nature et énergie des rayonnements) sont connus d'emblée ou peuvent être reconnus lors de la reconstitution de l'accident. Les paramètres géométriques source - sujet sont plus difficiles à reproduire. Enfin, la durée d'exposition est souvent mal appréciée.

Aussi les méthodes de dosimétrie physique sont elles parfois insuffisantes pour fournir la totalité des données nécessaires à l'évaluation de la dose et de sa répartition.

Il est donc indispensable de recourir aux méthodes biologiques qui sont fondées sur l'analyse des effets, eux-mêmes en rapport direct avec les doses délivrées.

Nous nous proposons de montrer l'efficacité de l'association de méthodes physiques et de méthodes biologiques en nous appuyant sur plusieurs cas d'irradiation accidentelle globale aiguë, suivis dans le Service de Radiopathologie de la Fondation Curie.

Trois accidents ont été retenus : le premier survenu à VINCA, en 1958, le deuxième survenu à MOL, en 1965, le troisième survenue en ITALIE, en 1975 (13 Mars 1975)

Lors du premier accident, 6 sujets ont été irradiés par des neutrons et des photons gamma provenant d'une réaction nucléaire. La géométrie source - sujet permet de considérer l'irradiation comme homogène. Les doses ont été comprises entre 200 et 500 rads. Nous ne retiendrons de ce cas que quelques données hématologiques.

\* Service de Radiopathologie de la Fondation Curie - Institut du Radium - 26 rue d'Ulm - 75005 Paris (France).

\*\* C.N.E.N. - Viale Regina Margherita 125 - 00198 Roma (Italie).

\*\*\* I.P.S.N. - Département de Protection C.E.A. - Boîte postale n°6 - 92260 Fontenay-aux-Roses (France).



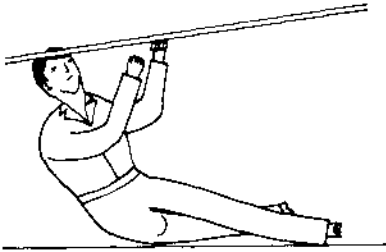

Cas n° 1

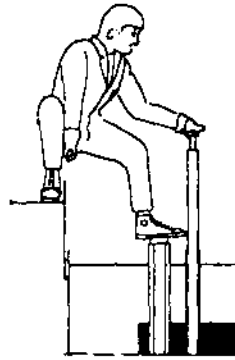

Cas n° 2

Fig. 1 Position des sujets lors de l'exposition

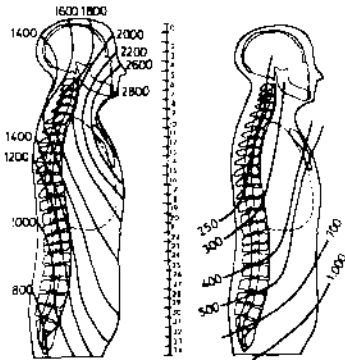

Cas n° 1

Cas n° 2

Fig. 2 Isodoses dans le plan sagittal médian

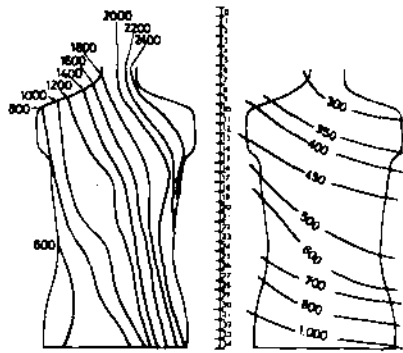

Cas n° 1

Cas n° 2

Fig. 3 Isodoses dans le plan frontal médian

Organe	Cas n° 1	Cas n° 2
Cerveau (1/2 droite / 1/2 gauche)	1600-2000 / 1200-1600	200-300 / 200-300
Hypophyse	1800	330
Pharynx-oesophage	2000-2200	
Thyroïde	2000-2200	300
Coeur	1400-2000	400-450
Rate	2000	400
Foie	1200-1400	400-500
Colon transverse	1000-1800	450-500
Surrénales (droite / gauche)	800 / 1600	350-400 / 350-400
Reins (droit / gauche)	800 / 1600	400-500 / 400-500
Bonades	1600	> 1100

Tableau 1

Comparaison des doses absorbées au niveau de différents organes des cas 1 et 2

Cas n° 1		Cas n° 2	
Intervalle de dose (rad)	Pourcentage de moelle concernée	Intervalle de dose (rad)	Pourcentage de moelle concernée
400-800	13	200-300	16
800-1200	33,3	300-350	17
1200-1600	33,7	350-400	11
1600-2000	4,45	400-500	8
2000-2400	13,5	500-1000	48
2400-2800	1,3		
2800-3200	0,75		

Tableau 2

Comparaison des doses absorbées au niveau des territoires médullaires des cas 1 et 2

Lors du deuxième accident, un sujet a été irradié par neutrons et par photons gamma, par un flash de criticité. L'irradiation était hétérogène; la dose moyenne était de 550 rads. L'évolution clinique s'est déroulée sur plusieurs mois et des investigations physiques et biologiques très complètes ont pu être effectuées.

Lors du troisième accident, un sujet a subi une irradiation par photons gamma d'une source de  $^{60}\text{Co}$ . Il s'agissait d'une irradiation hétérogène; la dose moyenne était de 1 200 rads. L'évolution a été rapide et la mort est survenue le treizième jour.

Nous désignerons au cours de l'exposé par sujet n° 1 l'accidenté d'ITALIE et par sujet n° 2 l'accidenté de MOL.

## 2. DOSIMETRIE PHYSIQUE

La géométrie source - sujet est reconstituée par l'interrogatoire, par l'analyse des circonstances, et éventuellement par la répétition des gestes sur le lieu de l'accident.

Ainsi pour le sujet n° 1 (figure 1) le bras et l'épaule gauches, la face antéro-latérale gauche du cou et l'extrémité céphalique étaient très proches de la source. A l'inverse, pour le sujet n° 2 c'est le membre inférieur gauche qui était très proche de la source. On va donc observer, dans ces deux cas, une très grande hétérogénéité de distribution des doses.

Les conditions d'exposition sont reproduites en utilisant un fantôme muni de dosimètres. Le fantôme du type Rando est constitué d'un matériau équivalent aux tissus mous pour les rayonnements photoniques et comporte un squelette réel et des poumons en matériau équivalent. Ce fantôme est constitué de 31 tranches comportant des emplacements destinés à recevoir 320 dosimètres. Les dosimètres utilisés sont des dosimètres thermoluminescents et des plaquettes de FLI - Téflon.

Les résultats sont rapportés d'une part à la surface et d'autre part au niveau des divers territoires de chacune des tranches du fantôme.

Les mesures externes montrent pour le sujet n° 1 une importante hétérogénéité de répartition avec grande prépondérance cervico-thoracique antéro-latérale gauche. Chez le sujet n° 2, la répartition est également très hétérogène, mais la distribution des doses est très différente. La dose maximale au niveau du oeil gauche diminue de bas en haut, d'avant en arrière et de gauche à droite.

Les mesures internes permettent d'évaluer la répartition de la dose avec une très grande précision. Les courbes isodoses construites à partir de ces mesures permettent d'appréhender d'une manière synthétique la répartition des doses et dans les deux cas présents l'hétérogénéité et les différences de distribution.

Dans le plan sagittal médian (figure 2) on observe pour le sujet n° 1 que la dose est maximale au niveau de la moitié antérieure du cou et décroît d'avant en arrière. Cette distribution explique l'évolution clinique dominée par une nécrose pharyngée précoce. Pour le sujet n° 2 on observe essentiellement que les vertèbres cervicales et les huit premières vertèbres dorsales ont reçu une

dose inférieure à 300 rads, ce qui explique que la survie ait été possible malgré la dose moyenne de 550 rads.

Dans le plan frontal médian (figure n°3) on observe pour le sujet n°1 que la dose est supérieure à 1000 rads pour la quasi totalité du tronc, qu'elle atteigne 2 400 rads au niveau de la partie latérale gauche du cou. Pour le sujet n°2 les doses au niveau du tronc se répartissent entre 1 000 rads pour la partie inférieure de l'abdomen et 300 rads pour la partie supérieure du thorax.

Les doses organe sont établies à partir des mesures effectuées à l'aide du fantôme (tableau n°1). On constate pour le sujet n°1 que pratiquement toutes les doses sont supérieures à 1 200 rads, de telle sorte que malgré l'hétérogénéité de la répartition, le pronostic est fatal. Pour le sujet n°2 au contraire, les doses pour la plupart des organes, sont comprises entre 200 et 500 rads, ce qui permet de discuter des chances de survie.

Il est primordial de considérer les doses délivrées aux territoires médullaires (tableau n°2). Leur niveau et leur répartition conditionnent la survie du sujet et orientent la thérapeutique. Dans le premier cas, 87 % de la moelle a reçu une dose supérieure à 800 rads et 13 % une dose comprise entre 400 et 800 rads entraînant une aplasie médullaire précoce. Dans le second cas, les doses délivrées au niveau du rachis cervical et des premières vertèbres dorsales sont comprises entre 200 et 300 rads. Le pourcentage de moelle concernée par ces doses est de 16 %.

L'apport de la dosimétrie physique a été dans ces deux cas fondamental quoiqu'inégal.

Dans le deuxième cas, la bonne détermination des caractéristiques d'émission, la bonne connaissance de la géométrie source - sujet, et la durée quasi-instantanée de l'exposition ont permis une évaluation dosimétrique physique très précise.

Dans le premier cas les caractéristiques d'émission étaient également bien connues; la géométrie source - sujet était assez bien définie en raison de l'exiguïté du lieu d'exposition et du caractère très limité des gestes effectués par le sujet; mais une incertitude demeurait quant à la durée d'exposition.

La dosimétrie physique a donc fourni avec une grande précision les débits de dose et la répartition topographique. Toutefois, la détermination des doses absolues a nécessité l'apport des données biologiques.

### 3. DOSIMETRIE BIOLOGIQUE

Toutes les données cliniques et biologiques sont intéressantes à considérer en vue de l'évaluation de la dose. Mais parmi ces dernières les données hématologiques et chromosomiques sont fondamentales; elles sont le témoin très précis des doses délivrées. Par ailleurs, certaines des manifestations cliniques et biologiques sont très précoces et leur étude permet d'acquiescer très rapidement, avant même qu'aient été pratiquées la reconstitution physique de l'accident, les notions essentielles pour l'établissement du pronostic et les prévisions thérapeutiques.

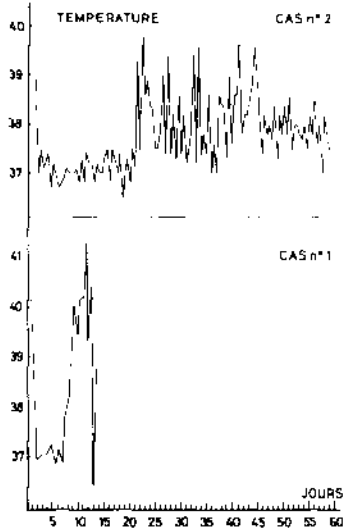

Fig. 4 Evolution thermique

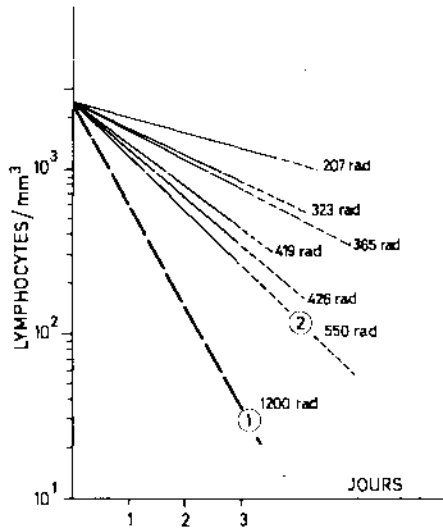

Fig. 5 Chute initiale des lymphocytes

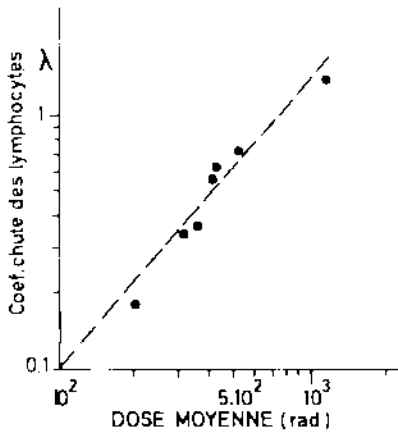

Fig. 6 Relation entre la chute initiale des lymphocytes et la dose

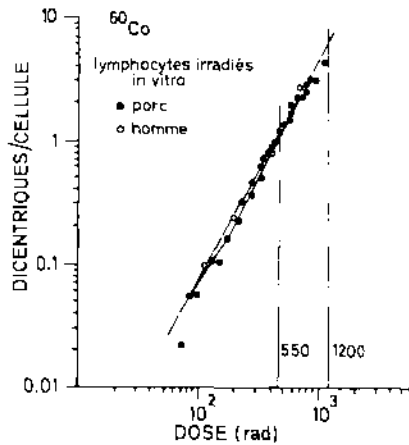

Fig. 7 Relation entre le nombre de dicentriques et la dose, après irradiation in vitro chez l'homme (d'après BIOLA et col.) et chez le porc (d'après HAAG et col.)

Les signes généraux traduisent le degré de gravité. Les signes locaux renseignent sur le caractère homogène ou hétérogène de la répartition de la dose.

L'évolution clinique se déroule en quatre phases :

- une phase de choc initial caractérisée par des nausées et des vomissements survenus dès la 30<sup>ème</sup> minute pour le sujet n°1 et à la 2<sup>ème</sup> heure pour le sujet n°2 et par une hyperthermie;
- une phase de latence qui a été de 9 jours pour le sujet n°1 et de 3 semaines pour le sujet n°2;
- une phase critique caractérisée par une asthénie intense conduisant à la prostration, par l'existence de céphalées, d'obrubilation, d'hyperthermie (41,3° pour le sujet n°1);
- une dernière phase qui est, soit une phase de rémission, soit une phase terminale.

L'intensité de la phase initiale et la durée de la phase de latence traduisent la gravité de l'irradiation. Les courbes de température (figure n°4) témoignent des différentes phases évolutives et de leurs durées respectives.

Les signes cliniques locaux témoignent également du niveau de dose par leur délai d'apparition et leur intensité, et renseignent, en outre, sur la répartition topographique de la dose.

Ainsi, les données cliniques permettent d'apprécier, dans une large mesure, l'importance de l'irradiation et de juger son caractère homogène ou hétérogène, mais elles n'autorisent pas une évaluation quantitative de la dose.

Parmi les données biologiques, nombreuses sont celles qui, comme les données cliniques, reflètent le niveau d'irradiation. L'expression quantitative de ces données permet, pour certaines d'entre elles, d'établir des relations précises avec les doses. Les plus intéressantes sont médullaires, hématologiques, chromosomiques.

Pour les deux sujets, sur de multiples prélèvements médullaires pratiqués au cours des premiers jours, la moelle était totalement déserte. Pour le sujet n°2 toutefois, des ponctions plus tardives effectuées au niveau de différents territoires médullaires ont confirmé le caractère aplasique de tous les territoires sauf de la région cervicale, ce qui confirmait le caractère hétérogène de la répartition des doses et le niveau inférieur à 200 rads au niveau de la moelle cervicale.

Toutes les lignées des éléments figurés sont affectées, mais c'est l'analyse des modifications relatives aux granulocytes et surtout aux lymphocytes qui permet une évaluation dosimétrique précise.

Le taux des polynucléaires neutrophiles subit deux types de modifications importantes.

Dans les heures qui suivent l'exposition on observe un pic. Ce phénomène a été enregistré pour le deuxième sujet. Le taux absolu des granulocytes totaux était de 16 100 par  $\text{mm}^3$  à la 6<sup>ème</sup> heure; le taux des granulocytes neutrophiles était de 12 500 par  $\text{mm}^3$ . Pour le sujet n°1 le pic initial n'a pu être enregistré mais le taux des polynucléaires neutrophiles était de 7 500 par  $\text{mm}^3$  dès le 2<sup>ème</sup> jour.

Par la suite, la chute du taux des granulocytes neutrophiles est rapide. Le taux de 100 granulocytes est atteint dès le 10ème jour pour le sujet n°1 et le 21ème jour pour le sujet n°2. Pour ce dernier, le taux minimal est de 14 granulocytes au 23ème jour. Les pentes de chute comparées pour tous les sujets exposés lors des trois accidents s'ordonnent en fonction de la dose.

La chute du taux des lymphocytes est très précoce. Pour le sujet n°2 le taux minimal était de 140 par  $\text{mm}^3$  ; il a été atteint au 4ème jour. Pour le sujet n°1 on observe, dès le troisième jour un taux inférieur à 100 par  $\text{mm}^3$ .

Comme pour les granulocytes les pentes de chute des lymphocytes pour les sujets exposés au cours des trois accidents s'ordonnent en fonction de la dose (figure n°5). La représentation sur une échelle Log/log de la pente de chute en fonction de la dose (figure n°6) semble correspondre à une relation linéaire. Ainsi la précocité, la sensibilité, la forme de la réponse du taux des lymphocytes autorise, dès le premier jour, une évaluation précise du niveau de la dose délivrée.

La fréquence des altérations chromosomiques des lymphocytes sanguins après exposition aux rayonnements ionisants est fonction de la dose. La comparaison des données numériques des deux sujets avec des courbes de référence obtenues à partir de lymphocytes du porc et de l'homme irradiés *in vitro* par le rayonnement photonique du cobalt 60 (figure n°7) a conduit à une évaluation de la dose moyenne de 1200 rads dans le premier cas et de 550 rads dans le second cas.

#### 4. CONCLUSION

Lors d'une exposition accidentelle à une source de rayonnements ionisants, la dosimétrie physique fournit toujours les débits de dose. Elle permet de préciser la répartition topographique lorsque la géométrie source - sujet est bien connue. Elle peut enfin conduire à la détermination précise des doses lorsque la durée d'exposition est en outre bien définie. C'est le cas pour le sujet n°2.

Mais souvent ces derniers paramètres sont mal connus et les données biologiques sont alors d'un intérêt majeur. Les signes cliniques généraux initiaux rendent compte immédiatement du degré de gravité. Les signes cliniques locaux attestent du caractère homogène ou hétérogène de la répartition.

Les données médullaires et hématologiques générales permettent d'apprécier le degré de gravité; la pente de chute des lymphocytes et l'étude des anomalies chromosomiques, notamment la fréquence du nombre de dicentriques par cellule permet une évaluation très précise de la dose moyenne.

Ainsi les méthodes physiques et biologiques apparaissent complémentaires et leur association permet l'évaluation très précise des doses et de leur répartition.

## REMERCIEMENTS

Les auteurs tiennent à exprimer leur gratitude et leurs remerciements à tous les médecins et scientifiques qui leur ont apporté sans mesurer leur peine une aide précieuse :

- Messieurs V. PRODI et L. LEMBO, R. BOULENGER,
- Madame N. PARMENTIER, Messieurs M. CHEMTOB et G. PORTAL,
- Monsieur R. LE GO, Madame M.T. DOLOY et Monsieur J.L. MALARBET,
- Messieurs G. ASTALDI, A. FAVINO et M. FAES,

ainsi que le Laboratoire d'Analyses Médicales et le Laboratoire Hématologique de la Fondation Curie, les Laboratoires du Département de Protection - IPSN - CEA, les Laboratoires médicaux et hospitaliers français et étrangers.

## RADIATION INJURY FROM ANALYTICAL X-RAY EQUIPMENT

I.S.Sundara Rao, P.S.Lyer, A.Kannan, S.P.Zaparde and G.Subrahmanian  
Division of Radiological Protection  
Bhabha Atomic Research Centre  
Trombay, Bombay-400 085  
India.

## 1. INTRODUCTION

During the last two decades there has been a considerable increase in the use of analytical X-ray equipment in research centres and industries in India. The energy range of X-rays generated by these machines is less than 25 Kev and these X-ray tubes are provided with negligible inherent filtration. As a result, the exposure rates near the tube windows are extremely high. Most of these low energy radiations will be absorbed within the first few millimetres of tissue (1). If the absorbed dose to the skin is sufficiently high, there is a distinct possibility of formation of significant dermatitis, which if present for sometime, can lead to skin cancer.

Several reports of injury caused by radiations from X-ray analytical equipment have been reported (2). This paper presents two cases of inadvertent acute exposure to low energy radiation from X-ray crystallography units. The paper also analyses the possible causes of these accidents. Based on our experience accumulated during the radiation protection surveys of such X-ray analytical equipment, several measures to avoid recurrence of such incidents and also to reduce radiation hazards in routine work are recommended.

## 2. CASE I

This is a case of radiation burn in the inner forearm of the right hand caused by acute exposure from an X-ray crystallography unit. The incident occurred on August 9, 1974.

## 2.1. History

Mr. N, aged 37 years and his colleague were working with an X-ray crystallography unit. The unit has two beam windows at  $180^\circ$  to each other and both were 'ON' simultaneously. It is intended that whenever only one beam is used the other should be closed by inserting a lead shutter. On the forenoon of the day of this incident, it was told that Mr. N had closed the beam on the right side as only the left beam was used. After lunch, the work was resumed and while manipulation of the experimental set-up, both hands were used. The work was continued



for about 15 minutes when it was suddenly realised that the shutter of the right beam was not present and that the inner forearm of the right hand was receiving radiation exposure from the direct beam.

A blood count, taken on the next day was found to be normal and there were no biological symptoms during the first week. After about 14 days, an elliptically shaped wound of major and minor axis 5 and 3 cm respectively, had developed. The wound was 5 mm deep. As per the prescription of the local physician, antibiotic ointment was applied on the wound which healed after about three months.

Corresponding to the wound area, a white elliptical patch still remained when observed in January 1976. Mr. N had no other symptoms at this time and no numbness in the affected region. Pigmentation has started from the fringes to about 2 mm inside this area. Surrounding the white patch an area of about 20 cm x 5 cm from the centre of the forearm towards the ankle has a darker appearance. There was epilation in this area initially with no subsequent hair growth. Mr. N recalled that he was holding his right hand in a stationary position at about  $45^{\circ}$  to the beam for nearly 2 to 3 minutes and that this particular exposed region had developed into a wound subsequently. The elongated shape of this patch is in conformity with the oblique incidence. The regions which got exposed during the remaining time when the hand was not stationary might have got lesser dose resulting only in change of skin colour.

## 2.2. Dosimetry

The dosimetry was performed by reconstructing the incidence. Mr. N's right hand would have been at about 15 cm from the window of the tube through which the beam was emerging. The exposure rate was measured at this place using a calibrated soft X-ray ionisation chamber and found to be 4,444 R per minute. Considering the Roentgen-to-rad conversion factor as 0.9 for skin, the dose rate would be 4000 rads per minute. For an exposure time of 2-3 minutes, the skin dose would have been 8,000 to 12,000 rads.

## 3. CASE II

### 3.1. History

This was a case of severe skin reaction on the inner three fingers of the left hand reported in July, 1972. Mr. K, aged 36 years, noticed some changes in the skin of his fingers and experienced burning sensation associated with pain in the fingers. He developed blisters on the left index finger and raised patches on the middle and ring fingers. During this acute phase, the patient was given oral antibiotics and skin ointment containing antibiotics and hydrocortison. A clinical examination early in August, 1972 revealed a healed scar of about 1 1/2 cm x 1 cm on the medial aspect of the left index finger while raised patches of 2 x 1 cm with slight depigmentation were seen on the middle and ring fingers. Marked pigmentation was noticed on the distal phalanges extending to the middle phalanges on the left hand and on the index finger on the right hand.

An investigation established that Mr. K was in the habit of holding a 5 cm fluorescent screen strip in the beam to locate its position and size, and to align the camera. The image on the screen due to

uncollimated beam is brightly visible even at a distance of one meter without darkening the room, whereas the small image due to a collimated beam could be observed only in close proximity in a darkened room. Mr.K used to remove the collimator during alignment and replace the collimator into the camera with the beam still 'ON'. In this process, his left hand fingers, particularly his index and middle fingers were in the direct beam. The diameter of the beam at the finger position was about 3 cm.

### 3.2. Dosimetry

The exposure rate was measured to be about 22,000 R per minute at 25 KV and 20 mA. It was established by mock exercises that in the process of inserting the collimator into the camera, Mr.K's fingers were in the direct beam for 3-4 seconds in each of the 4 or 5 occasions when he used the new unit after installation. These operations would have resulted in a dose in the range of 4000-6500 rads to the index finger. The thumb had been shielded by the index finger and no dermatitis was seen on the thumb. The dose to the middle and ring fingers on the left hand was estimated as 1000 rad. He also used to hold the fluorescent screen with his right hand and this explains the pigmentation seen on the right index finger.

## 4. RADIATION SAFETY

A significant reason for such incidents is the low standard of radiation safety features built into many of the X-ray analytical equipment(3,4). In this connection 59 X-ray analytical units of different makes as seen in Table 1 were studied. Of these, 52 units are used for crystal structure determination, 3 for thermal expansion study, 2 for study of diffraction from metals and alloys and 2 for studies of soils and clays. 56 of these had manual control, 2 automatic and 1 semi-automatic. 38 units had single targets and 21 had multitargets. The availability of radiation safety features is detailed in Table 2. A majority of these units do not have interlocking systems or radiation barriers.

It is to be pointed out that in both the incidents discussed here, the units were of the same make. No distinctive warning light which will glow when the X-ray beam is 'ON' was interlocked to the high tension. Also, electrical or mechanical interlocks which will ensure that the shutter will be in position for blocking any unused beam were absent. Incorporation of the above features in addition to a radiation alarm monitor and an interlocking device to prevent the entry of any part of the body into the direct beam and education of the working personnel regarding awareness of radiation hazards will definitely help to reduce unnecessary exposure from X-ray analytical equipment.

TABLE 1. Number of X-ray analytical units of different manufacturers

S.No.	Manufacturer	No. of units
1.	Radon House (Indian make)	31
2.	Philips	19
3.	General Electric	3
4.	Rich Seibert	3
5.	Picker	1
6.	Ray Max	1
7.	Other	1
Total		59

TABLE 2. Availability of radiation safety facilities

S.No.	Radiation safety facility	Available	Not Available
1.	Beam trap	45	14
2.	Safety shutters	46	13
3.	Temporary shielding	54	5
4.	Interlocking system	15	44
5.	Barrier	14	45
6.	Lead glass for viewing	44	15
7.	Warning indicators	38	21
8.	Radiation symbols	30	29
9.	Radiation survey instruments	19	40
10.	Film badge service	16	43

#### REFERENCES

1. URBACH, F., FORBES, P.D. "The acute and chronic effects of ionizing radiation on skin", Radiation safety in X-ray Diffraction and Spectroscopy, USDHEW Publication No.(FDA) 72-8009, Washington (1971).
2. INDELL, B., "Occupational hazards in X-ray analytical work", Health Physics 15 (1968) 481.
3. STERN, B.E., "AURPO Survey of safety devices on X-ray crystallography/diffraction sets", Health Physics 20 (1971) 358.
4. ROBERTSON, M.K., "Safety features of X-ray diffraction equipment in New Zealand", Health Physics 24 (1973) 547.

## ETUDE D'UN CAS DE CONTAMINATION PAR UN MELANGE DE RADIONUCLÉIDES

L. Jeanmaire<sup>\*</sup>, J.C. Harduin<sup>\*\*</sup>, P. Beau<sup>\*</sup>, H. Frossard<sup>\*\*\*</sup>, J.C. Nénet<sup>\*</sup>,  
 J. Ballada<sup>\*</sup>, M.L. Daburon<sup>\*</sup>, R. Gros<sup>\*</sup>, F. Patti<sup>\*</sup>, G. Odilon<sup>\*\*</sup>,  
 L. Cappellini<sup>\*</sup>, M. Garret<sup>\*</sup>

## 1. INTRODUCTION

Au cours d'une réparation effectuée sur les tuyauteries d'une cellule de dissolution de combustible irradié, un ouvrier s'est blessé à travers ses gants avec les barbes d'un tuyau antérieurement contaminé.

Dès son arrivée au service médical, il a reçu du DTPA en intraveineux et en application locale, avant décontamination aussi grande que possible de la main. Au 22<sup>ème</sup> jour, une intervention chirurgicale a permis d'enlever la plus grande partie de la contamination de la blessure.

## 2. RADIONUCLÉIDES IDENTIFIÉS

Le tableau 1 montre les 16 radionucléides mis en évidence dans les excréta (urines et selles), le corps entier ou le tissu contaminé de la blessure. Tous les éléments n'ont pas été mesurés régulièrement, mais les rapports ont été déterminés entre chaque élément et un élément de référence qui possède des caractéristiques physiques, chimiques ou biologiques comparables, et qui a été mesuré pendant plusieurs mois.

## 3. URINES

L'élimination de plusieurs nucléides importants a été suivie régulièrement. Chaque injection de DTPA augmente l'élimination du plutonium, des autres émetteurs  $\alpha$  et du  $^{144}\text{Ce}$ , mais reste sans action sur le  $^{90}\text{Sr}$ . L'élimination des transplutoniens est plus forte que celle du plutonium durant les cinq premiers jours ; ensuite, elle est inférieure.

## 4. MAIN

Des mesures d'émetteurs  $\gamma$  ont été faites sur la main, avant et après exérèse ainsi que sur les tissus provenant de l'opération. Les résultats du tableau 2 montrent que l'activité résiduelle après l'opération ne dépasse pas 1 % de la quantité initiale, et que les pourcentages retrouvés dans les tissus sont les mêmes pour la plupart des radionucléides. La composition relative aurait donc peu évolué entre le 13<sup>ème</sup> et le 23<sup>ème</sup> jour.

Les émetteurs  $\alpha$  ont été mesurés dans les tissus après séparation chimique. Le tableau 3 montre les résultats des mesures dans les tissus et les urines jusqu'au moment de l'opération chirurgicale. Les pourcentages des divers émetteurs sont différents dans la main et dans les urines, mais globalement ils correspondent à la composition de la solution indiquée par l'exploitant. Deux remarques essentielles peuvent être formulées : le plutonium a diffusé moins facilement hors de la blessure que le curium et l'américium ; le DTPA a eu une action efficace.

\* Département de Protection - Service de Protection Sanitaire -  
 Commissariat à l'Energie Atomique - BP n° 6 92260 FONTENAY AUX ROSNES.

\*\* Laboratoire d'Analyses Médicales - Centre de la Hague

\*\*\* Service Médical du Travail - Centre de la Hague BP n°209 50107 CHERBOURG.

## 5. CORPS ENTIER

La spectrométrie  $\gamma$  in vivo (main exclue) a permis de mettre en évidence par ordre de difficulté croissante, le  $^{137}\text{Cs}$ , le  $^{95}\text{Zr}$  et le cérium. Par contre, le ruthénium n'a pas été vu.

## 6. INTERPRÉTATION DES MESURES D'EXCRETION

Pour évaluer les charges des organes critiques et les doses engagées, nous pouvons rassembler dans une première catégorie les isotopes du plutonium, du cérium, et les transplutoniens dont l'excrétion est modifiée par l'administration de DTPA.

Pour les émetteurs  $\alpha$  du plutonium, la démarche suivie a consisté à faire des bilans comparatifs successifs entre les quantités excrétées et les quantités restant au niveau de la porte d'entrée, en tenant compte de la poursuite ou de l'arrêt du traitement médical. L'évaluation de la charge osseuse a été faite à partir des valeurs de l'excrétion urinaire obtenues à distance du traitement en utilisant le modèle d'excrétion urinaire de DURBIN.

Dans le cas de  $^{241}\text{Pu}$ , émetteur  $\beta$ , on a retenu que, dans la solution contaminante, il avait une activité vingt-six fois plus élevée que la somme des activités des émetteurs  $\alpha$ .

Pour les transplutoniens, les proportions observées dans la solution contaminante étant retrouvées dans l'ensemble des tissus excisés + urines jusqu'à l'excision, on a admis que ces proportions étaient respectées dans le tissu osseux et on en a déduit les charges correspondantes.

Dans le cas du cérium, on a suivi la démarche adoptée pour le plutonium. Le résultat de spectrométrie du corps entier, main exclue, est en assez bon accord avec les valeurs de la charge sanguine initiale déduite de l'excrétion urinaire à distance du traitement; on a retenu selon la C.I.P.R. 10 que 30 % de cette valeur de la charge sanguine se fixe dans l'os.

La seconde catégorie est représentée par  $^{89}\text{Sr}$  et  $^{90}\text{Sr}$  pour lesquels on a supposé un passage rapide de la porte d'entrée au sang. Sur cette base, les résultats de l'excrétion urinaire et les données de la C.I.P.R. 20 sur le métabolisme des alcalins terreux ont permis d'évaluer la charge sanguine initiale.

## 7. CONTAMINATION GLOBALE

Il nous a semblé intéressant d'estimer les quantités totales de chacun des radionucléides ayant pénétré dans l'ensemble de l'organisme, et de calculer les rapports de ces valeurs à celles de la solution initiale. Le tableau 5 montre que pour le plutonium, le cérium, le zirconium et le strontium les rapports sont groupés entre 4 et 14. Le césium se détache avec un rapport égal à 100. Compte tenu de toutes les imprécisions de ces déterminations, on peut estimer que la première série de valeurs est constante, et que la contamination initiale a été provoquée par l'équivalent de 1/100 de microlitre de la solution. Pour le césium, on constate, sans pouvoir l'expliquer de façon satisfaisante, que la contamination initiale correspond à un volume dix fois plus grand. En effet, si l'on admet que le césium a pénétré préférentiellement dans la blessure, entre la contamination et la première décontamination externe, un phénomène analogue aurait dû se produire pour le strontium; et ce n'est pas le cas. Comme autres hypothèses, on peut imaginer une contamination antérieure par le césium, ou une composition différente de celle admise pour le tuyau contaminé; en réalité ces deux hypothèses paraissent peu vraisemblables.

## 8. CONCLUSION

Au plan analytique comme au plan dosimétrique, le problème essentiel dans une contamination de ce type est donc constitué par les isotopes du plutonium et les transplutoniens qui ne sont pas tous directement mesurables et qui délivrent à eux seuls, près de 99 % de la dose à 1'05, dont 56 % pour les émetteurs  $\alpha$  du Pu, 28 % pour le  $^{241}\text{Pu}$ , et 16 % pour les transplutoniens. La comparaison de la composition de la solution contaminante, avec les résultats observés chez le sujet contaminé permet, seule, de déterminer les limites de la contamination pour ceux des radionucléides qui ne sont pas accessibles directement à la mesure.

Les résultats détaillés seront publiés dans un rapport C.F.A.

Groupe	Elément chimique	Radioisotope	Rapports au jour $t_0$
Alcalin	Cs	137	
Alcalino terreux	Sr	90 - 89	$^{89}\text{Sr}/^{90}\text{Sr} = 1,7$
Terres rares	Ce	144 - 141	$^{141}\text{Ce}/^{144}\text{Ce} = 0,05$
	Pm	147	$^{147}\text{Pm}/^{144}\text{Ce} = 0,5$ (urine) = 0,6 (tissus)
	Y	91	$^{91}\text{Y}/^{144}\text{Ce} = 0,3$ (urine) = 0,3 (tissus)
			$^{103}\text{Ru}/^{106}\text{Ru} = 0,33$
Divers	Ru	106 - 103	
	Zr et Nb	95 95	$^{95}\text{Zr}/^{95}\text{Nb} = 0,8$
Transuraniens	Pu	239 - 240	
		238	$^{238}\text{Pu}/^{239}\text{Pu} + ^{240}\text{Pu} = 0,176$
		241	$^{241}\text{Pu}/^{239}\text{Pu} + ^{240}\text{Pu} = 20$
	Am	241	Am/Cm = 0,26 (main) = 0,33 (urine) = 0,29 (solution)
			$\alpha \text{ Pu}/\text{autres } \alpha$ : variable (cf. Tableau 4).
		Cm	242

TABLEAU 1 Eléments mis en évidence - Rapport au jour  $t_0$

Élément	Main (avant exérèse)	Tissus excisés		Main (après exérèse)		Élimination			
	nCi à J <sub>13</sub>	nCi à J <sub>23</sub>	% éliminés	nCi à J <sub>57</sub>	% restants	de J <sub>13</sub> à J <sub>22</sub>	de J <sub>22</sub> à J <sub>57</sub>	total nCi	total %
<sup>141</sup> Ce	12	7,65	79	non visible					
<sup>141</sup> Ce	230	180	78	1,36	0,64	21,5	6	27,5	12
<sup>103</sup> Pu	11,5	7,8	80	non visible					
<sup>106</sup> Pu	34,5	27,5	80	non visible					
<sup>137</sup> Cs	3,6	0,54		0,18					
<sup>95</sup> Zr	113	82,3	83	0,725	0,94				
<sup>95</sup> Zr	139	100		1,345					

\* on a tenu compte de la décroissance physique depuis J<sub>13</sub>

TABEAU 2 Mesures des éléments émetteurs  $\gamma$  concernant la main

	Main tissu excisé		Urine de J <sub>13</sub> à J <sub>22</sub>		Total		Solution %
	nCi	%	nCi	%	nCi	%	
alpha du Pu	10,1	71	4,6	42	14,7	59	59
<sup>242</sup> Cm	3,2	23	4,8	44	8,0	32	32
<sup>241</sup> Am	0,86	6	1,6	14	2,4	10	9
Total	14,16		11,0		25,1		100

TABEAU 3 Emetteurs  $\alpha$  retrouvés à J<sub>22</sub>

Composition solution (Ci l <sup>-1</sup> )	Élément	Main (tissu excisé)	Élimination urine	Corps (sans main)	Organisme (total)	Total Org solution $\times 10^6$
4,3	Pu ( $\alpha$ )	10	4,6	5-10 (estimé)	20-25	5 à 6
100	<sup>141</sup> Ce	180	410	400 ± 100 %	600 à 1400	6 à 14
180	Zr - Nb	180		500 à J <sub>0</sub>	700	1
10	Cs	0,5		1000 à J <sub>0</sub>	1000	100
30	<sup>106</sup> Pu	34,5			?	
15 ?	<sup>90</sup> Zr	0,03		100 à J <sub>0</sub> (estimé)	100	7

TABEAU 4 Estimation en nanocuries de divers radionucléides introduits dans l'organisme. Equivalents de ces quantités en volume de la solution initiale

A PROPOS D'UN CAS DE CONTAMINATION PAR INHALATION  
ACCIDENTELLE D'OXYDE DE  $^{239}\text{Pu}$  = ANALYSE DE L'EPURATION PULMONAIRE

P. BEAU<sup>\*</sup>, J.C. HARDUIN<sup>\*\*\*</sup>, H. FROSSARD<sup>\*\*\*</sup>, J.C. NENOT<sup>\*\*</sup>

## 1. INTRODUCTION

Après inhalation de particules d'oxyde de  $^{239}\text{Pu}$ , on considère habituellement que l'épuration de l'appareil respiratoire s'effectue selon les processus systématisés dans le modèle de dépôt et d'élimination pulmonaire du "Task Group on Lung Dynamics" de la CIPR (1). Du point de vue quantitatif, ce modèle distinguant 3 classes de composés selon leur degré de transférabilité, l'oxyde de  $^{239}\text{Pu}$ , peu transférable, prend les caractéristiques de la classe Y. L'épuration par voie digestive étant importante pour cette classe de composés, on a la possibilité par l'analyse des fèces de suivre l'évolution d'une contamination et d'en apprécier l'importance. En effet, cet examen reflète l'épuration de tous les compartiments de l'appareil respiratoire et, en particulier, à distance de la contamination, de la fraction à période d'élimination longue, l'excrétion du Plutonium par voie biliaire étant comparativement faible.

Le modèle pulmonaire retient la valeur de 500 j pour la période correspondant à la rétention à long terme d'un composé de la classe Y. Cette valeur permet, dans la pratique, de faire une évaluation de la dose engagée au poumon lorsque la surveillance du sujet contaminé sur une durée encore trop limitée et le nombre trop restreint d'analyses n'autorisent pas à calculer une valeur de cette période correspondant à l'épuration pulmonaire propre à la personne considérée.

Dans le cas de contamination unique par inhalation de  $^{239}\text{Pu}$  que nous présentons, la surveillance de l'épuration de l'appareil respiratoire par l'analyse des fèces a pu être poursuivie pendant 600 jours ce qui nous a permis d'étudier l'épuration pulmonaire du sujet.

## 2. ANALYSE DES RESULTATS

La méthode de surveillance a consisté à obtenir du sujet 3 selles correspondant à l'excrétion de 3 jours consécutifs. L'examen des résultats montre la grande irrégularité de l'excrétion journalière du Plutonium (tableau). Nous avons donc travaillé sur les valeurs moyennes qui figurent en regard des résultats élémentaires. Les 4 derniers résultats correspondent également à la moyenne de l'excrétion de 3 jours successifs.

En considérant l'ensemble des résultats moyens, on constate, à côté des résultats qui varient peu entre eux, l'existence de trois points discor-

\* IPSN - Département de Protection - Commissariat à l'Energie Atomique - BP 6 - 92260 FONTENAY AUX ROSES (France)

\*\*\* Laboratoire d'Analyses Médicales et Service Médical du Travail  
CEA Centre de La Hague - BP 209 - 50007 CHERBOURG (France)



dants. Le premier est le résultat à J+12, anormalement élevé pour cette date. Il peut s'agir soit d'une variation aléatoire de l'excrétion journalière soit de la fin de la période d'épuration rapide puisque celle-ci se poursuit théoriquement sur une dizaine de jours (2). Le second résultat discordant à J+197, également élevé, ne semble pouvoir être relié qu'à une variation aléatoire de l'excrétion sachant qu'il ne peut correspondre à une période courte, ni même à une période intermédiaire, une telle composante n'étant plus significative au delà de 100 j (3). Enfin le dernier point obtenu, à J+606, est extrêmement bas. Il est le seul point que l'on possède depuis J+411, venant à la suite d'une série de résultats qui, mis à part celui de J+197, diffèrent peu entre eux depuis J+41.

Dans ces conditions pour évaluer la période d'élimination pulmonaire à long terme, nous avons été amenés à faire deux régressions linéaires. La première en excluant le résultat à J+12 conduit à une période de 132 jours qui est plus faible que les valeurs habituellement rencontrées (courbe 1 de la figure). La seconde conserve le point à J+12, mais élimine le résultat à J+606 en attendant qu'un nouvel examen vienne confirmer ou infirmer la tendance donnée par ce point. Cette seconde régression conduit à une période de 470 jours (courbe 2 de la figure). En comparant les deux régressions, on voit que les deux hypothèses jouent peu sur les activités initiales car les ordonnées diffèrent de moins d'un facteur 2. Par contre l'écart observé entre les périodes modifie considérablement la dose engagée au poumon. Aussi pour ne pas courir le risque de la sous-estimer, avons nous retenu pour l'évaluation dosimétrique la période de 470 jours. La charge pulmonaire à vie longue déduite des valeurs de la régression est d'environ 14 nCi.

### 3. CONCLUSION

On voit que l'interprétation des données radiotoxicologiques en vue d'individualiser par rapport à un modèle, les différentes phases de l'épuration pulmonaire d'un sujet contaminé est difficile. Même avec des résultats à long terme, l'interprétation est malaisée, car la signification de certains résultats n'est pas claire. De plus, le fait de ne pas connaître la granulométrie des particules inhalées augmente la difficulté de l'interprétation.

### REFERENCES

- (1) "Task Group on Lung Dynamics" Report., Health Phys., 12, 2 (1966) 173; et ICRP Publication 19, Pergamon Press 1972
- (2) MENOUX, B., BEAU, P., NENOI, J.C., Communication n° 361 ce Congrès AIRP 1977
- (3) WATTS, L., Health Phys., 22, 1 (1975) 53

Tableau : Résultat d'excrétion fécale

Date j	Excrétion journalière pCi	Valeurs moyennes pCi
j j+1 j+2	735 4000 525	
j+10 j+12 j+13	51 40 47,2	46
j+40 j+41 j+42	10,50 3 3,50	5,7
j+56 j+57 j+58	18,40 2 1,55	7,32
j+75 j+76 j+77	7,40 11 4,30	7,6
j+96 j+97 j+98	11 7,40 2,75	7
j+197 j+248 j+414 j+606		28,5 7,7 6 0,17

# ACTIVITE FECALE EN PCI/J

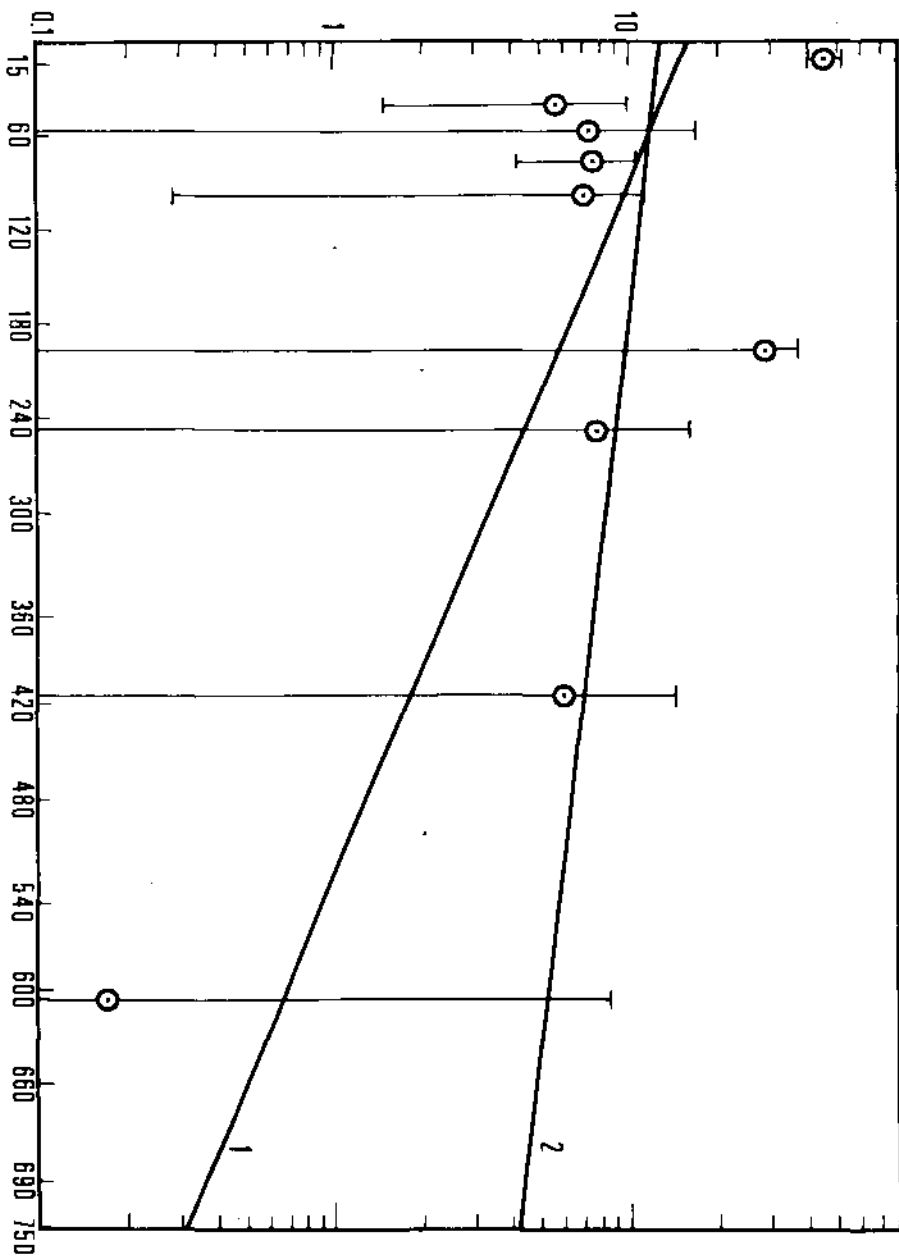

A RADIATION CONTAMINATION INCIDENT INVOLVING  
STRONTIUM 90 IN A PRIVATE HOME

A.W. Fleischmann  
Officer in Charge  
Radiation Branch  
Health Commission of  
New South Wales  
Lidcombe N.S.W. 2141  
Australia

and

J.C.H. Button  
Head, Health and Safety  
Section  
Australian Atomic Energy  
Commission  
Lucas Heights N.S.W. 2234  
Australia

## 1. INTRODUCTION

In October 1975 a private electronic service contractor, operating in his home workshop, drilled a hole through a Strontium 90 (15 mCi) capsule while attempting to clear a collimating hole. The capsule was part of a glass bottle thickness gauge and the contractor was engaged to improve the performance of the electronic portion of the equipment. An examination of the source container and beam collimating hole had indicated to him that part of the problem was due to accumulated lubricant in the collimator having hardened as a result of "bombardment by beta particles" to use his own words. Normal solvents would not remove the material.

Four days passed before he realised that he had damaged the source and informed the authorities. The subsequent contamination was found to be spread over himself, his wife, the family pet (a dog), the workshop and living area of the home, furniture, carpets, garden and paths around the home.

Four officers from the Health Commission of New South Wales and a further four from the Australian Atomic Energy Commission (A.A.E.C.) took a total of four weeks to clean the house to the stage where it could again be occupied. A considerable volume of workshop equipment, furniture and personal belongings could not be decontaminated on site and were removed for later treatment. Much of this has now been stored for ultimate disposal.

In December 1976 the service contractor was fined a total of \$300 for possessing and handling a radioactive substance without having a license under the New South Wales Radioactive Substances Act.

## 2. CONTAMINATION

Degrees of contamination were measured in the workshop area, the living area and outside of the house.

### 2.1 Workshop

This room is about 4 metres x 4 metres and an adjoining office/library is about 4 metres x 3 metres. An open staircase leads from the workshop to the living area of the house. An open doorway joins the workshop to the office area.

External beta radiation fields up to 5 millirads per hour were measured initially in the centre of the workshop. Contamination levels, in the workshop, in excess of 300 derived working levels (where 1 DWL =  $10^{-4}$   $\mu\text{Ci cm}^{-2}$ ) were found on the main work bench and adjacent floor area. The surface beta dose rate on this bench was around 200 millirads per hour. The rest of the workshop was contaminated to levels considerably below these and varied between 10 and 50 DWL.

Levels in the office/library were generally around 1 DWL and, after removal of the contaminated carpet and a small number of other items, this area would be used as a "clean" area and a charge barrier was established in the doorway to the workshop.

## 2.2. Living Area

This area includes a lounge room, dining room, kitchen, bedroom, bathroom, toilet and laundry. The stairs from the workshop enter this area in the dining room.

The highest contamination level was found on an area of carpet in the lounge room where the level rose to 250 DWL and the surface dose rate was 250 mrad/hour. Isolated areas in the bedroom gave 120 DWL (about 100 mrad/hour) and 80 DWL (70 mrad/hour) in the kitchen.

Generally contamination was found on virtually every object in the house and varied between 1 and 10 DWL.

## 2.3. Clothing

The clothing worn by the serviceman on the occasion of the first meeting with Health Commission officers had areas that were contaminated to 250 DWL. This included his cardigan, trousers and shoes.

His wife's clothing was considerably less contaminated and did not exceed 20 DWL. Even this was only in some small areas and the overall contamination level was around 5 DWL.

## 2.4. Persons

The serviceman's hair was reading approximately 20 DWL, his hands 4 DWL and his mouth 1 DWL. He is in the habit of putting the side of his hand to his mouth and this would account for much of the strontium-90 there.

His wife showed almost no contamination and the family dog was slightly contaminated on the fur and paws. This could be removed by clipping the fur and washing the paws.

After showering and washing the serviceman's hair dropped to a contamination level of under 1 DWL and the only other contamination that could be detected was a slight amount under the finger nails.

Close clipping and scrubbing removed this to a degree where it could no longer be detected.

### 3. PROCEDURES

3.1 Because of the high degree of contamination of the house and workshop it was imperative to remove the serviceman and his wife to allow decontamination procedures to proceed without interruption.

The need for medical surveillance of both persons made it a convenient solution to place both in an isolated ward of a large hospital in Sydney.

3.2 As mentioned earlier (section 2.1.) a change area was provided between the workshop and the office area. This suited the team working in that particular part of the house.

The team working in the living part of the house established a change area at the front door and proceeded through the house room by room.

This scheme, although ideal, had a number of weaknesses that rapidly became obvious. These included:

3.2.1 the only toilet and washroom was near the rear of the house and members of both teams frequently had to pass through contaminated areas to reach these points

3.2.2 the telephone was in the kitchen and there was a frequent need for persons to pass through contaminated areas to either make or to receive telephone calls

3.2.3 the teams generally changed into work clothing in the garage next to the house and put on overshoes, gloves, respirators at the change area. This area was clearly visible from the street and caused some inconvenience to the teams, particularly after the incident became known and both newspapers, radio stations and television channels became interested.

3.3 To allow some movement through the house and to prevent spread of the contamination, plastic sheeting was spread over the entire floor area and over the more heavily contaminated furniture items.

3.4 The main equipment used included:

3.4.1 vacuum cleaner with absolute filter, borrowed from the Australian Atomic Energy Commission.

3.4.2 Nuclear Enterprises Contamination Monitor types PCM3 and PCMS with type DP2R probes.

3.4.3 Mini Instruments scintillation meter type 540 with Mullard MX168 tube (actually a geiger unit).

3.4.4 Copious amounts of plastic bags, plastic sheets, cotton waste, detergent, carpet cleaner, buckets and general cleaning material.

3.4.5 protective clothing; overalls, overshoes, gloves, respirators (borrowed from the A.A.E.C.).

3.5 The criteria for deciding that an area was clean was that recommended by the International Commission on Radiological Protection (I.C.R.P.)(1) namely, a fixed contamination level of  $10^{-4}$   $\mu\text{Ci}/\text{cm}^2$  which is 1 D.W.L. and which was equivalent to a count rate of 40 counts per second (40 c.p.s.) on the P.C.M.3.

3.6 In most cases the level could be reduced to below 1 D.W.L. by simple vacuum cleaning aided by some rubbing in more stubborn spots.

In the case of the workshop bench, paint stripper had to be used and even then some contamination remained (about 4 D.W.L. as against an original level of around 130 D.W.L.). The bench was then dismantled and classified as waste.

The workshop floor was covered with old linoleum and after this was removed the contamination level could soon be reduced to an acceptable amount.

In the living area a number of soft furniture items, small parts of the carpet, some bedding material and a quantity of clothing had to be removed for disposal.

The majority of workshop tools and some books also had to be removed.

3.7 After four weeks of work and following the removal of numerous sacks of goods the home could again be declared fit for occupancy. Some of the goods removed were later cleaned in the A.A.E.C. decontamination facility but a large quantity was classified as waste.

#### 4. OVERALL LESSONS LEARNT

4.1 The most fundamental lesson is to be prepared for incidents of this type which may occur at any time, take an enormous amount of staff, time and equipment to rectify and the need to have a basic emergency procedure as well as a stock of suitable decontamination equipment.

4.2 Our Branch was very fortunate, and grateful, to be so near to an Atomic Energy Research Establishment, which is well equipped with decontamination equipment and expertise. That establishment also has a first class medical physics section which was able to carry out, and interpret, the whole body counting and bioassay procedures. Unfortunately time does not permit me to elaborate on the medical aspects. (2,3)

It is difficult to imagine how we could have managed these procedures on our own, as well as the decontamination task, with our own staff which comprises five scientific officers and relatively limited equipment.

4.3 The need for greater control over the movement and general possession of radioactive substances was clearly demonstrated. It should, however, be noted that the person referred to as a service technician is in fact a highly qualified engineer with an honours degree in electrical engineering and considerable experience in nucleonics.

The lesson to be learnt is that qualifications alone do not prevent incidents of this type from occurring. The real preventative lies more in the methods of control, supervision and implementation of a licensing or registration scheme.

#### REFERENCES

- (1) I.C.R.P. Publication 2 "Report of Committee 2 on Permissible Dose for Internal Radiation".
- (2) I.C.R.P. Publication 10 "Report of Committee 4 on Evaluation of Radiation Doses to Body Tissue from Internal Contamination due to Occupational Exposure".
- (3) I.A.E.A. Technical Report Series No. 142 "Inhalation Risks from Radioactive Contamination".



## A CASE OF FELONIOUS USE OF RADIOACTIVE MATERIALS

Edgar D. Bailey  
Martin C. Wukascn

Texas Department of Health Resources  
Austin, Texas (USA)

Introduction

On January 31, 1974, the Radiation Control Branch, Texas Department of Health Resources (the Agency), was notified by a telephone call from the step-father of a young boy that the boy's father had exposed the son to radioactive materials on several occasions in 1972 and that the exposures had resulted in radiation burns on the thighs, ankle, and thumb. In accord with Agency policy, the step-father was asked to put his accusations in writing. On February 4, 1974, the Agency received a letter from the step-father in which he identified the father and the name of the father's company, outlined the time, places, and methods used in the exposures, and the symptoms and injuries of the child. The name of the plastic surgeon who had made the diagnosis of radiation injury was also given. Attached to the letter were a list of sixteen doctors who had examined and/or treated the child in the previous year and a half, and sketches of the sources, handling tools, and the radiation survey meter that the child had seen.

Following the receipt of the letter and its attachments, the Agency telephoned a physician who had performed numerous medical examinations of radiation injury victims and asked him to talk to the physicians who had seen the boy. He was requested to examine the boy if in his judgment the previous diagnosis of radiation injury had merit. The physician, who at the Agency's request had been sent a copy of the letter, said that the plastic surgeon who had made the diagnosis was extremely qualified to recognize such an injury since he had performed plastic surgery on many cancer patients who had undergone radiation therapy.

Although a check of the Agency's radioactive materials licensing files did not reveal that a license had ever been issued in the father's name or in the name of the father's company as given to us by the step-father, one of the Agency's inspectors recognized the father's name. He recalled having met the father during an inspection of a license issued in the name of a different company. A review of that company's license file revealed that the company had been first licensed on November 18, 1971, to possess and use a sealed source containing one curie of <sup>137</sup>Cs for oil and gas well logging.<sup>1</sup> By two subsequent amendments, authorization had been granted to possess and use a maximum of two sealed sources each containing two curies of <sup>137</sup>Cs.<sup>2,3</sup> The review also confirmed that the father, a petroleum engineer, was the only named user on the license.

Shortly after these discoveries, the physician that the Agency had contacted concurred in the diagnosis of radiation injury following his examination of the boy.

On February 7, 1974, the Agency, realizing that the laws<sup>4</sup> and regulations<sup>5</sup> concerning radiation were inadequate to deal with what was felt to be a felony crime, notified the District Attorney in Houston, Harris County, Texas, of the allegations and the Agency's findings up to that time.

Upon review of the Agency's findings and the medical history of the boy, the District Attorney decided that a felony had been committed and assigned an Assistant District Attorney from his Special Crimes Bureau to lead the District Attorney's investigation and prosecution of the case.

Investigative Phase

From this point on all aspects of the Agency's investigation were coordinated with the District Attorney's office, and the investigation, discovery of witnesses, and the development of evidence were approached very cautiously. The Agency was acutely aware of the fact that none of its inspectors had had any experience or training in the investigation of criminal offenses and strove to conduct the investigation carefully. All proposed investigative actions were approved by the District Attorney's office in order to protect the admissibility of any evidence that the Agency might uncover.

Likewise, the Assistant District Attorney assigned to the case realized that the District Attorney's staff lacked experience in the fields of health physics, radiation effects, and the regulations, procedures, and practices of a radioactive materials regulatory program and had minimal knowledge of how radioactive sources were manufactured or how they were used in the oil and gas well logging industry.

Because both the Agency and the District Attorney's office each realized its own limitations, the files of each agency were opened to the other agency and the findings, plans, and ideas of each were freely and carefully discussed.

During the investigative phase, which began with the notification of the District Attorney's office and continued up to and during the trial, the investigation of possible sources of evidence were divided by categories of people being questioned. The District Attorney's staff questioned and developed evidence from the victim, his family, and doctors who had examined or treated the victim while the Agency's inspectors interviewed source manufacturers and oil and gas well loggers. While this pattern of investigation developed, there was never any formal division of effort nor was any such division ever discussed; it just occurred.

It should be noted that during this time, the Agency outwardly maintained a normal relationship with the father. In particular, the routinely scheduled inspection was performed and the radioactive material which he was licensed to possess and use was not impounded or confiscated until after he had transferred the material to another company and had asked that his license be terminated. While it may seem rather strange not to have impounded or confiscated the radioactive material prior to that time, an unusual circumstance regarding his storage location allowed the Agency to do it without further jeopardizing his son. The only authorized storage location for the radioactive material was at another licensee's facility, and that licensee had agreed to notify the Agency immediately if the father came to get the sources.

### Indictment and Trial Phase

On May 2, 1974, a grand jury indicted the father on five felony counts involving the use of radioactive material:

1. Assault with intent to murder.
2. Castration.
3. Disfigurement.
4. Assault with intent to maim.
5. Intentionally causing injury to a minor.

The same day the father was arrested. Bail was set at \$50,000.00, but was later reduced to \$10,000.00, and he was released on bond.

The case was heard in the 179th District Court of Harris County, Texas, by a six-man, six-woman jury beginning March 31, 1975. During the course of the trial, the prosecution presented sixteen witnesses including the boy, his mother, his younger brother, two present and one former Agency staff members, a plastic surgeon, a radiologist, a pediatric urologist, a pediatric endocrinologist, a radiation biophysicist, a psychiatrist, a radiation pathologist, a dermatologist, a source manufacturer, and a drilling and oil well service contractor. The defense presented seven witnesses including the defendant, two medical records clerks, a neighbor, an oil well supply contractor, a psychiatrist, and a health physicist.

From trial testimony, it was determined that the father and mother of the boy were married in December 1955 and that out of this marriage there were two children, the victim and a younger brother. The parents were divorced in May 1970 but remarried in July 1970 and were subsequently divorced again in February 1971. The mother of the boy had married the boy's step-father in December 1971. The terms of the divorce permitted the father visitation rights with the two boys on two weekends each month, normally the first and third weekends.

Evidence introduced at the trial indicated that on at least five and possibly as many as eight occasions between April 1972 and October 1972, the father irradiated the son by placing the <sup>137</sup>Cs sources on or near the boy's body. The exposures occurred during weekend visitations.

The first known irradiation occurred in April 1972 while the boy, age 11, was visiting the father's apartment. On this occasion, the boy was left alone in the apartment to watch television after being told to listen to the television only with earphones. Inside each earphone, the boy found a "little metal cylinder." In court, he identified "dummy" sources that had been prepared as resembling the cylinders he had seen.

During the victim's first visit with his father in July 1972, he was asked to drink a glass of orange juice with a pill dissolving in it. Shortly afterwards, he went to sleep on the couch in the den. Upon awakening, he found two cylinders in a pair sock under the cushion or which he had been sleeping. At this time, he also saw a source handling tool on a nearby end table. The following morning the boy was nauseous, and vomited.

At the second visit during July 1972, the child was again given orange juice with a dissolving pill in it. Because there was a party in the apartment, the boy was sent to sleep in the bedroom. Upon awakening the next morning, he heard a rattling noise in the pillow. A medicine bottle containing three metal cylinders was found in the pillow. The father and younger brother were found to be sleeping in another apartment. Again the boy was nauseous. About this time, the boy's thighs had developed what was then believed to be a rash.

The next known exposure occurred during August 1972. By this time, the lesions on the boy's thighs had become more serious, and he was under the care of a doctor. During the visit, the boy was instructed to lie on a couch while the father and younger brother went out. He found a sock with two cylinders in it under the cushion of the couch. After the father's return, the boy saw the father carry the sock at arm's length out to his car.

The last known exposure occurred at a visit during a visitation in October 1972. Again the child was given orange juice with a dissolving pill in it before going to bed. When he awoke, he found a sock with two cylinders in it draped over his legs. The father was found sleeping in his car.

The lesions on the boy's thighs and legs became progressively worse and he was under continual doctor's care. The causative agent for the lesions could not be determined, and they failed to respond to treatment. Finally in December 1973, a plastic surgeon was called upon to perform skin grafts. Upon examining the lesions, he diagnosed the injury as "... radiation necrosis. Necrosis ulceration due to radiation."<sup>6</sup>

The lesion on the boy's ankle (Figure 1) revealed "... deep indolent ulceration..."<sup>7</sup> and "... a terdon which was dead due to the effects of the radiation there."<sup>8</sup> The lesions on the boy's thighs (Figure 2) showed extensive ulceration and scarring with telangiectasia.

Following diagnosis of the causative agent as radiation (and it should be noted that the diagnosis was made prior to any knowledge of the possibility that the boy could have been exposed), testicular biopsy revealed that the right testicle had been replaced with fibrous tissue and that the left testicle was a small, hard, non-functioning testicular body. Further medical testing revealed that he had no functioning testis<sup>9</sup> which "in the medical term... is castrated"<sup>10</sup> and that as a result, "he will need testosterone replacement for the rest of his life."<sup>11</sup>

Chromosomal analyses were performed by expert witnesses for both the prosecution and the defense. The testimony of the prosecution's witness revealed that six multihit aberrations including three reciprocal translocations (identifiable only by karyotypic analysis) were noted in 200 lymphocytes studied. Although the defense witness' analysis showed only three multihit aberrations at the time of the trial, his analysis had not included karyotyping since he had less than three weeks to perform his analysis prior to presenting his testimony. Subsequent re-evaluation which included karyotyping has shown perfect agreement. It is interesting to note that the prosecution's witness obtained her sample of blood approximately four years post-irradiation, and the defense's witness obtained his sample a year later.<sup>12</sup>

Following the conclusion of testimony, the charges of assault with intent to murder, assault with intent to maim, and intentionally causing injury to a minor were dropped by the prosecutor. The last two which had been felonies under the old penal code were dropped because the new Texas penal code<sup>3</sup> had reduced these offenses to misdemeanors. The assault with intent to murder was dropped because the prosecution felt that it was unable to prove beyond a reasonable doubt that the father's intention was to kill the boy rather than just injure him, and that if convicted on that count, the decision would be subject to reversal by the appellate court.

On April 16, 1975, the case went to the jury. After deliberating ten hours, the jury on April 17, 1975, returned a verdict of guilty to the charge of castration. Since the father, as permitted under Texas law,<sup>4</sup> had selected at the onset of the trial for the jury to assess the punishment if convicted, the jury was then sent out to set the punishment. After deliberating only an hour, the jury assessed the maximum punishment for the offense, ten years in prison and a fine of \$5,000.00. On May 16, 1975, the sentence was formally pronounced, and the father's visitation rights with that son were revoked.

#### Post-Conviction Developments

Prior to the trial, the boy had undergone eleven plastic surgery operations and faces the possibility of several more as he matures. In addition to the testosterone replacement medication to prevent eunuchism with resulting obesity and to retain masculine characteristics, he faces an undetermined increased likelihood of developing leukemia.

Following the pronouncement of sentence, the father filed an appeal with the Court of Criminal Appeals of Texas, the final appellate court in Texas for criminal cases. Texas law permits persons sentenced to prison terms of less than fifteen years and a day to post an appeal bond and remain free until the appeal is heard. The father posted a \$10,000.00 bond and is now free pending appeal. The Court of Criminal Appeals of Texas is expected to review the case by June 1977.

Although the father and mother are presently involved in litigation regarding child support, the father still has visitation rights with the younger brother, albeit the visitation must occur in the mother's home or at such other places as she designates under her supervision.

#### Conclusions

This type of criminal case presents unique problems for the prosecutor because it involves dealing with the aura of mystique and fear that surrounds anything radioactive in the eyes of the ordinary layman. To people used to seeing the immediate results of an assault on an individual, the concept of an assault which results in observable injury only after a latent period of weeks, months, and even years following the assault and may be cumulative in effect is difficult to comprehend. The prosecution has to learn a new vocabulary and new physical concepts and must rely upon the use of expert witnesses from outside the normal law enforcement and prosecution organizations. In this particular case, no witnesses from the established law enforcement or prosecution organizations were called to testify. The payment of fees of expert witness and thereby the quality of their expert testimony, can be a major concern; however, in this particular case almost all of the prosecution's expert witnesses declined to accept their professional fees.

To the Radiation Control Regulatory Agency, the criminal nature of the case posed problems due to its staff's lack of training and experience in criminal law and criminal investigation procedures and techniques. The Radiation Control Agency must cooperate closely with the prosecution in the investigation, the preparation of exhibits, and the discovery of expert witnesses. It must also be willing to devote a large amount of staff, time, and a significant amount of travel and per diem money throughout what can be an extended period of time. Normally the people assigned to such an investigation should be persons with a broad base of training and experience and numerous personal contacts among the Agency's licensees.

While this particular case has been successfully prosecuted and we feel will be upheld in the appeals court, it has raised six significant questions:

1. Does the licensing procedure to obtain radioactive materials need to be more stringent so that a vigorous examination is made of the applicant's background and actual necessity to possess radioactive materials?
2. Since the injuries went unrecognized for a long period of time even though the boy was seen by numerous respected doctors would the cause of death have been identified if a lethal exposure had occurred and the boy had died prior to the development of lesions?
3. Along that same line, have there been other, perhaps unnoted, intentional criminal uses of radioactive materials?
4. How many apparently "crank" calls regarding radiation have been summarily disregarded without adequate investigation into the accusations?
5. Do the laws concerning the possession and use of sources of radiation need to be rewritten to include specific penalties for their criminal use, especially considering the normal statute of limitations that exists for assaults with other weapons?
6. Are present criminal laws adequate to deal with the radiation-induced leukemias and other cancers that may appear years after the exposure? Suppose in this case, the father's conviction is overturned on appeal and the child later develops and dies from leukemia, should not he be indicted on some murder charge? The American prohibition against double jeopardy seems to rule out further indictment.

\* The authors know of no other conviction, or even indictment, for the intentional criminal use of a source of radiation and would appreciate any other indictments and/or convictions being brought to their attention.

Acknowledgments - The authors wish to express their deepest appreciation to Michael J. Hinton and Cheryl Fariss of the office of the District Attorney, Harris County, Texas, for their total cooperation and support throughout this incident and the preparation of this paper. The continued support and advice of Vincent P. Collins, M.D., in this case and many other radiation injury incidents is greatly appreciated. We would also like to express our appreciation to Thomas D. Cronin, P.D., for granting permission to use his photographs in this paper.

#### REFERENCES

1. Texas State Department of Health Radioactive Material License No. 8-1655, dated November 18, 1971, Texas Department of Health Resources, Austin, Texas.
2. Texas State Department of Health Radioactive Material License No. 8-1655, Amendment No. 1, dated March 17, 1972, Texas Department of Health Resources, Austin, Texas.
3. Texas State Department of Health Radioactive Material License No. 8-1655, Amendment No. 2, dated August 2, 1972, Texas Department of Health Resources, Austin, Texas.
4. Texas Radiation Control Act, Article 4590f, Revised Civil Statutes, State of Texas.
5. Texas Regulations for Control of Radiation, Texas Department of Health Resources, Austin, Texas.
6. State of Texas vs. Kerry Andrus Crocker, 179th District Court of Harris County, Texas, Court Transcript (Case No. 212, 734), p. 815.
7. *Ibid.*, p. 818.
8. *Ibid.*, p. 817.
9. *Ibid.*, p. 1076.
10. *Ibid.*, p. 1077.
11. *Ibid.*, p. 1079.
12. Stewart C. Bushong, personal communication (telephone), January 12, 1977.
13. Texas Penal Code as revised, effective January 1, 1974.
14. Article 37.07, Texas Code of Criminal Procedures.



Figure 1. Lesion on Leg near the ankle

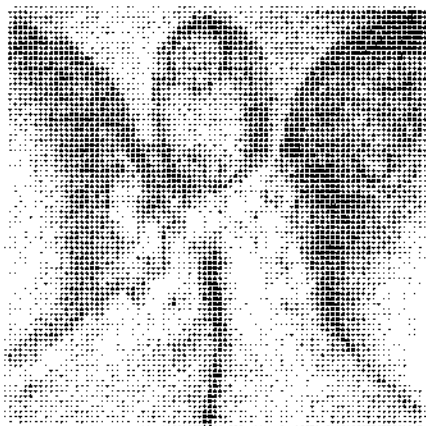

Figure 2. Lesions on Thighs and Perineum

THE VALUE OF RECONSTRUCTION OF RADIATION INCIDENTS

G.C. JARDINE  
N.T. HARRISON

National Radiological Protection Board, Scottish Centre.

Radiation incidents resulting in severe somatic damage, thankfully rare, are always the subject of detailed scientific investigation.

Incidents resulting in radiation exposure at lower dose levels, with perhaps less immediate significance should also be treated in a similar manner to ensure that a factual and accurate record of the incident and the resulting personal exposure to radiation is compiled.

Employers in the United Kingdom have a legal obligation to keep radiation dose records on behalf of their employees and if these records are to be meaningful and accurately reflect the employees dose then incidents must be investigated and a reconstruction carried out.

Under normal operating conditions in the workplace a controlled and defined radiation area exists and a personal monitor which measures the dose at or near the surface of the body will achieve, in a very high percentage of cases, an adequate assessment of average whole body dose.

Under incident conditions this control breaks down and a situation may be produced where the worker is exposed inadvertently to intense and variable radiation fields. In normal but more specifically in these incident conditions a highly complex relationship between the radiation field and the dose to the organs and tissues of the worker's body exists. Dose rates will vary as a function of distance and time and the dose delivered to individual organs will depend on the type and energy of the radiation, the orientation of the worker relative to the radiation field and the distortion of the field due to scattering or absorption of the primary radiation by material located in the radiation area. Consequently the personal monitor may no longer give an accurate assessment of dose.

It is because of such doubts about the exposure of a worker that reconstruction of incidents are so important and of such value. A good reconstruction will give early notice of the severity of the incident, assessment of both organ and average whole body dose and a first prediction of possible biological effect which may be important from a medical standpoint. The last is particularly relevant in irradiation of the male gonads where doses of the order of 25 rems are sufficient to warrant medical counselling on a very emotive aspect of radiation exposure.

The value and success of a reconstruction depends solely on first hand information available to the investigator. Experience has shown that speed in arranging such interviews is essential and that even relatively short delays can lead to serious omissions and inaccuracies in relevant detail. In any employment where much of the work is repetitive, detail is easily confused or may be completely forgotten or may be considered irrelevant after a short period of time.

Information regarding the incident reconstruction should be first hand and be taken not from one or two but from every worker involved. Individual statements should be taken and careful corroboration and cross-referencing of all relevant facts carried out. In framing the questions, care should be taken not to lead the interview and the questions should demand a descriptive answer as opposed to a bland affirmative or negative. On completion of the interviews careful assimilation of the statements will enable any contentious facts to be singled out for clarification or rejection.

Using the information derived from the interviews, a replica of the incident situation should be set up. The sources of radiation can be identified and radiation measurements made to determine important high dose rate regions. The incident situation should then be re-enacted as described with all the persons involved, not once but several times until all are agreed that the description and re-enactment is accurate and self-consistent. Experience has shown that this procedure leads to the most accurate recall and documentation of the incident. It is certainly not unique but in practice it has been found to be a very successful method.

Several repeats of the re-enactment are necessary to enable body movements, positions relative to the radiation source and a framework for averaging the corresponding times and distances to be established.

If it is shown from the reconstruction that a substantial variation in dose to different organs of the body is likely, an estimation of absorption in tissue of the particular radiation quality must be carried out using a phantom of tissue equivalent material to enable an estimate of dose at varying depths within the body to be made.

In calculation of depth doses to various organs the following depths below the front surfaces of the body are normally assumed.

Part of Body	Depth (mg/cm <sup>2</sup> )
Red bone marrow	2000
Male gonads	400-1000
Female gonads	7000
Eye lenses	300
Skin	5-10

Using the information from the reconstruction, dose equivalents should be calculated:-

- (i) for the whole body (average);
- (ii) for the region of the body surface on which any personal monitor is worn;
- (iii) to identify organs of maximum dose and dose in excess of erythema threshold;
- (iv) for the gonads if not included in (iii).

Where the average whole body dose appears on calculation to be significant, a sample of blood should be taken for chromosome aberration analysis.

Personal dosimeters if worn by the workers provide an important point of reference and the dose assessed from the personal dosimeter should be compared to that calculated from the reconstruction. If a personal monitor is not available for a comparison then it may be necessary to use the additional information from biological dosimetry or an estimate of dose from a clinical symptom.

If the agreement is good, the reconstruction may be confidently used to predict organ doses which may in fact prove to be clinically more significant than the average whole body dose and warrant additional special entry in the recipient's radiation dose record.

A recent incident investigated by the Scottish Centre of the National Radiological Protection Board occurred in a large fabrication workshop when a radiographer was accidentally irradiated while close to an X-ray tube.

An initial exposure dose of 200 R was predicted theoretically for the man whose film badge, when processed indicated a dose equivalent of 3.9 rems. Since the film badge dose appeared to be completely inconsistent with the exposure details a reconstruction to establish its validity as an indication of average whole body, organ and extremity dose was considered essential.

It was established during the search interview that the radiographer, though relatively stationary during the exposure had his back towards the X-ray tube thus shielding his film badge which was worn on the lapel of his overall.

Detailed re-enactment, followed by dose rate, energy and tissue absorption measurements resulted in a calculated dose for the body region covered by the film badge, of 3.5 rems. Thus, confident of the reconstruction, the maximum skin dose, mean bone marrow, gonad and average whole body doses were calculated to be 115, 60, 7 and 16 rems respectively.

In a blood sample sent for chromosome aberration analysis no dicentric were found giving an estimate of average whole body dose of zero rems. with a 95% confidence limit of 15 rems. The average whole body dose from the physical reconstruction, is not entirely inconsistent with the result from chromosome aberration analysis, but it indicated that the calculated value is probably a maximum.

Reconstruction may be summed up briefly as a method of ensuring good documentary evidence and the best possible estimate of dose equivalent for radiation incidents. The value of reconstruction is its ability:-

- (i) to overcome the deficiency of personal monitors in abnormal situations;
- (ii) to make a comprehensive assessment of dose;
- (iii) to identify organs of maximum exposure;
- (iv) to provide early indication of doses likely to be of clinical significance;

- (v) to record officially specific organ doses, thus adding more meaning to radiation dose records and to long term statistical studies on exposure to radiation;
- (vi) to document information which in the event of future litigation may be of special importance or significance to both employer and employee.



## DERIVED ERLs FOR INHALATION OF ALPHA-EMITTING AEROSOLS

H. F. Macdonald

Central Electricity Generating Board, Berkeley Nuclear Laboratories,  
Berkeley, GL13 9FB, UK.

Emergency dose limits recommended recently by the Medical Research Council (MRC) and improved dose-intake data for transuranic radionuclides enable limits for accidental exposure of the public to alpha-emitting fuel aerosols to be evaluated.

## 1. INTRODUCTION

Current arrangements at CEGB nuclear power stations for the initial assessment of inhalation hazards following a reactor accident leading to a release of radioactivity to the environment are based on the total  $\beta/\gamma$  count rates of air samples collected by mobile emergency survey teams (1). These measurements are made in the field and reported back to the emergency control centre by radio; they are followed up rapidly by detailed  $\gamma$ -spectrometric analyses of the air samples at the station district survey laboratory. In addition, the total  $\alpha$  count rates of the air samples are measured at this time in order to eliminate the remote possibility of a significant  $\alpha$ -hazard associated with actinide isotopes in the absence of a greater hazard due to the  $\beta/\gamma$  emitting fission products. A derived  $\alpha$  action level, expressed in  $\text{dpm}/\text{m}^3$ , is used and represents the airborne concentration of an assumed mixture of  $\alpha$ -emitters which if inhaled for a period of four hours would result in a dose commitment to the critical group in the exposed population no greater than the Emergency Reference Levels (ERLs) of dose recommended by the MRC (2). The period of four hours is selected as a realistic time within which to assess the severity of a release and initiate appropriate countermeasures.

## 2. INHALATION DOSES FROM THE TRANSURANICS

Dose-intake data for transuranic radionuclides inhaled as 1  $\mu\text{m}$  AMAD particles have been given in two recent reports (2,3); these considered doses to selected human body organs due to ingestion and inhalation of  $^{239}\text{Pu}$  and  $^{242}\text{Cm}$ , based upon the latest ICRP lung and GI tract models for the transuranics (4). The results of similar calculations of the adult inhalation doses to lung and bone for a more complete range of actinide isotopes are presented in Table I (5); these data also assume inhalation of a 1  $\mu\text{m}$  AMAD aerosol and lung clearance parameters appropriate to Class W (soluble) and Class Y (insoluble) compounds.

Isotope	Adult Dose per $\mu\text{Ci}$ Inhaled (rems/ $\mu\text{Ci}$ )			
	Soluble (Class W)		Insoluble (Class Y)	
	Lung	Bone	Lung	Bone
$^{238}\text{Pu}$	30	1400	300	510
$^{239}\text{Pu}$	28	1540	280	590
$^{240}\text{Pu}$	28	1540	280	590
$^{241}\text{Pu}$	0.012	31	0.89	13
$^{241}\text{Am}$	30	1600	300	600
$^{242}\text{Cm}$	25	31	80	4.5
$^{244}\text{Cm}$	31	806	284	280

TABLE I Dose Intake Data for Transuranic Radionuclides (5)

Although the dose distribution will vary with the particle size, the results for a 1  $\mu\text{m}$  AMAD aerosol are considered appropriate here since the variations are relatively small, being less than a factor of 2 for particles in the range 0.5-2  $\mu\text{m}$  AMAD in the worst case of insoluble Class Y compounds (3). The bone doses given are for a skeletal mass of 7000 g, with a Quality Factor of 10 and a Distribution Factor of 5 in accordance with current ICRP practice, and the data of Table I are in good agreement with other recently reported actinide dose-intake data (2,3,6).

As the transuranics are deposited primarily on bone surfaces, rather than throughout the volume of mineral bone, the relevant tissues are the endosteal surfaces for which the ERL of dose is 30 rem, the same as that for the lung (2). An estimate of the endosteal dose was obtained by increasing the bone doses of Table I by a factor of 3; this is equivalent to the use of a Distribution Factor of 15 and yields endosteal doses consistent with recent estimates by Thorne and Vennart (7). Further, as young children might form the critical group in the population, appropriate rems/ $\mu\text{Ci}$  inhaled were estimated from Table I; for the lung and  $^{212}\text{Po}$  irradiation of bone, where the dose is delivered over a few hundred days, the adult rems/ $\mu\text{Ci}$  values were increased by a factor of 10 for the reduced mass of the child's organs. Combined with a breathing rate approximately one-third of that of an adult, this leads to a net increase in the dose commitment by a factor of 3 for exposure of young children in the first year of life.

In the case of bone irradiation by the long lived actinides, where the dose is delivered essentially uniformly over the assumed 50 year integration period, the adult rems/ $\mu\text{Ci}$  inhaled values were increased by only a factor of 3 to allow for the reduced skeletal mass of children during the early years post-intake. With the reduced breathing rate mentioned above, this leads to similar dose commitments for exposure of adults and young children.

### 3. EVALUATION OF DERIVED ERLS

Total  $\alpha$  count rates equivalent to an ERL for Magnox and advanced gas-cooled reactor (AGR) fuels at zero and 1000 days cooling evaluated using the dose-intake data discussed above are presented in Table II. The fuel irradiation histories assumed were 4 GWd/T at 2.7 MW/T, and 18 MWd/T at 13 MW/T for Magnox and AGR respectively and the values quoted assume a four hour exposure as noted earlier. The total  $\alpha$  values equivalent to an ERL tend to increase with fuel burn-up, or on progressing from Magnox to AGR, but exhibit a reverse trend with increasing cooling time of the irradiated fuels. These effects arise from the increased build-up and subsequent decay of the relatively less radiotoxic, shorter lived isotopes of curium.

Cooling Period (days)		Total $\alpha$ Count $\equiv$ ERL (4 hour) dpm/m <sup>3</sup>			
		Magnox		AGR	
		Adult	Child	Adult	Child
Bone Class W	0	1.4x10 <sup>4</sup>	1.3x10 <sup>4</sup>	2.1x10 <sup>4</sup>	1.7x10 <sup>4</sup>
	10 <sup>3</sup>	2.9x10 <sup>3</sup>	2.9x10 <sup>3</sup>	3.0x10 <sup>3</sup>	3.0x10 <sup>3</sup>
Lung Class Y	0	1.7x10 <sup>5</sup>	5.0x10 <sup>4</sup>	1.9x10 <sup>5</sup>	5.6x10 <sup>4</sup>
	10 <sup>3</sup>	6.6x10 <sup>4</sup>	2.0x10 <sup>4</sup>	6.5x10 <sup>4</sup>	2.0x10 <sup>4</sup>
Bone Class Y	0	3.7x10 <sup>4</sup>	3.6x10 <sup>4</sup>	5.6x10 <sup>4</sup>	5.2x10 <sup>4</sup>
	10 <sup>3</sup>	7.1x10 <sup>3</sup>	7.1x10 <sup>3</sup>	7.6x10 <sup>3</sup>	7.6x10 <sup>3</sup>

TABLE II Total  $\alpha$  Count Rates Equivalent to an ERL for Irradiated Reactor Fuels

For completeness, total  $\alpha$  count rates equivalent to an ERL for unirradiated natural and enriched uranium fuels were evaluated; here the situation is complicated by the chemical toxicity of uranium which limits its intake in a soluble form by inhalation to 2.5 mg/day(8). Assuming a four hour exposure, this gives total  $\alpha$  ERLs of  $1.2 \times 10^3$  and  $2.7 \times 10^3$  dpm/m<sup>3</sup> for natural uranium and 2.5% <sup>235</sup>U enriched fuels respectively. For inhalation of insoluble material the lung dose is limiting, due to the much shorter biological half-life of uranium in bone compared with the higher actinides, and the corresponding  $\alpha$  ERL for a four hour exposure is  $2.4 \times 10^4$  dpm/m<sup>3</sup>.

The data of Table II show that the limiting  $\alpha$  ERLs for irradiated fuels are set by the inhalation doses to bone from long-cooled fuel particulates for both soluble (Class W) and insoluble (Class Y) materials. In the latter case, the ERL based on the dose to a child's lung is a factor of 2-3 times less restrictive than that set by the bone dose; this somewhat unusual result for insoluble material arises from the extremely long radioactive and biological half lives of the plutonium isotopes involved. These are principally <sup>241</sup>Pu and its <sup>241</sup>Am daughter, which account for  $\sim 50\%$  of the bone dose for the fuels considered here; <sup>239</sup>, <sup>243</sup>Pu, and for the higher burn-up AGR fuel the <sup>238</sup>Pu daughter of <sup>242</sup>Cm, are the other main contributors to the bone doses.

In contrast, for the unirradiated fuels there is more than an order of magnitude difference between the derived ERLs for material inhaled in soluble and insoluble forms. This is due to the relatively low specific activity of unirradiated low enrichment uranium fuels and the consequent limitations imposed by chemical toxicity.

Although any release of actinides in a reactor accident is likely to occur in an insoluble form in the chemical sense, this does not necessarily imply that they will behave as insolubles in the ICRP sense. Current radiobiological evidence on the transportability of inhaled transuranics, notably isotopes of plutonium, suggests that in some situations they can exhibit anomalously high solubility, particularly if inhaled as micron or sub-micron aerosols (9). In view of this uncertainty it is suggested that an emergency action level should be based on the soluble bone dose data of Table II; bearing in mind the possible equal importance of the dose to liver noted by MRC (2,3), and that the ERLs of dose refer to individual organs irradiated separately, this leads to a derived  $\alpha$  ERL of  $\sim 1.5 \times 10^3$  dpm/m<sup>3</sup> for a four hour exposure. This is only marginally greater than the value of  $1.2 \times 10^3$  dpm/m<sup>3</sup> for unirradiated natural uranium fuel discussed earlier.

#### 4. CONCLUSION

The occurrence of a significant airborne  $\alpha$ -hazard due to the actinide isotopes, in the absence of a more limiting hazard associated with the  $\beta/\gamma$  emitting fission products, is considered unlikely in most postulated reactor accident situations. The effects of the actinide content of fuel are only likely to be important in specialised circumstances, such as incidents resulting in the generation of fuel aerosols without preferential release of the more volatile fission product isotopes. Based upon the total  $\alpha$  levels equivalent to an ERL presented here, an appropriate derived  $\alpha$  ERL is  $10^3$  dpm/m<sup>3</sup>, ( $170 \text{ Bq m}^{-3}$ ) for a four hour exposure period; this value is equally applicable to incidents involving both unirradiated and irradiated reactor fuels.

This paper is published by permission of the Central Electricity Generating Board.

#### REFERENCES

1. MACDONALD, H.F., BALLARD, P.J. and THOMPSON, I.M.G. IAEA-SM-215/1, (1977).
2. MRC, "Criteria for controlling radiation doses to the public after accidental escape of radioactive material". HMSO, London (1975).
3. MRC, "The toxicity of plutonium". HMSO, London (1975).
4. ICRP, Publication 19. Pergamon Press (1972).
5. BAILEY, M.R. Private communication of unpublished data (1976).
6. McSWENEY, T.I. and HALL, R.J. BNWL-1846 (1975).
7. THORNE, M.C. and VENNART, J. Nature, 263 555, (1976).
8. ICRP, Publication 6. Pergamon Press (1964).
9. MOLE, R.H., BNKS Journal, 15 203, (1976).

## GROUND CONTAMINATION FOLLOWING AN ACCIDENTAL RELEASE

J. O. Corbett

Central Electricity Generating Board, Berkeley Nuclear Laboratories,  
Berkeley, Gloucestershire, UK.

Summary: Some long-term problems of ground contamination are discussed. It is concluded that the release of a plausible mixture of fission products from a reactor to the atmosphere can lead to  $\gamma$ -ray doses from the ground comparable in significance with the initial inhalation hazard, if no counter-measures are taken.

## 1. INTRODUCTION

For reactors operated by the CECB, the emergency plans concerning hazards to the general public are aimed first at obtaining a rapid assessment of dosage that may arise through inhalation. Later on, measurements of ground contamination are made over a wider area of country to establish the possible need for a temporary ban on certain foodstuffs. The greatest individual doses arise potentially from I-131 in milk, but the priorities for action place inhalation hazards first, because prompt evacuation may be needed in order to avoid them. In some cases ground contamination can give rise to additional radiation dosage accumulating over periods of several years, so that further countermeasures may be required on a less urgent time scale. In this paper we discuss the nature and implications of some of these long-term hazards.

## 2. CRITERIA FOR EMERGENCY ACTION

In the UK, the possible need for action to protect the public after an accidental release is assessed on the basis of Emergency Reference Levels (ERLs) of dose to the various organs of the body (1): where these doses are unlikely to be exceeded, action is deemed unnecessary. For practical purposes derived ERLs of more readily measurable quantities are used. In particular, ground contamination levels are specified for the nuclides I-131, Cs-137, Sr-89 and Sr-90, assuming that dosage to the thyroid, whole body and bone marrow respectively, occurs through the consumption of milk from cows grazing on contaminated pasture. These derived levels are appropriate criteria for deciding whether control of milk supplies is necessary.

The time for which such restrictive measures must continue is highly relevant to their practicability and cost. Contamination in milk from I-131 and Cs-137 can be effectively avoided by a ban of a few weeks duration, because of the short half-life of I-131 and the low rate at which caesium is transferred to vegetation once it has become fixed in the soil. Contamination with Sr-90 is more persistent, but strontium is unlikely to be released in significant proportions from a reactor accident because of its low volatility.

Significant dosage can also arise through  $\gamma$ -irradiation from nuclides on the ground. Here Cs-137 is of special importance on account of its long half-life (30 y) and its tendency to become fixed in the soil (2). A deposit of  $1 \mu\text{Ci}/\text{m}^2$  Cs-137 can give an exposure of 0.6 Roentgens in air at 1 m above ground in the 50 years following deposition (3), which may be compared with the 0.6 rem whole body dose (to a six months old child) that may arise from the same nuclide through the milk chain. The essential difference is the time for which the hazard persists, so that either decontamination or many years restriction of access would be required in order to avoid  $\gamma$ -ray dosage from deposited Cs-137. Other nuclides that may be released and lead to significant  $\gamma$ -dosage are Cs-134, Ru-106 and Ru-103, but their shorter half-lives result in a less persistent hazard.

A third mechanism for radiation dosage from ground contamination is resuspension as a respirable aerosol, which is mainly of concern in the case of long lived actinides. Although this complex process is hard to treat satisfactorily, a recent model (4), which allows a rate of resuspension gradually falling to a constant residual level, may be tentatively applied. It then appears that  $\mu\text{Ci}/\text{m}^2$  Pu-239 on the ground would give 10 rem to the child's lung over a few weeks, and a lung dose of 0.1 rem per lifetime to each succeeding generation. On this basis the possibility of contaminating significant areas with plutonium is well outside the range of accidents normally considered credible for a gas-cooled thermal reactor.

### 3. IMPLICATIONS FOR REACTOR ACCIDENTS

To put these matters in perspective, we now consider a hypothetical release. All the volatile and 1% of the non-volatile fission products are released from 1 kg of oxide fuel irradiated for 1000 days at 20 Mw/t in a thermal reactor. The released materials are dispersed in average atmospheric conditions (neutral stability, Pasquill Category D, with 5 m/s wind speed) and dry deposition takes place with a deposition velocity of 3 mm/s. From these assumptions it is possible to calculate the extent of areas where doses in excess of the ERL may arise by the various routes. Some of the release data and the results of the calculations are shown in Tables 1 and 2; the accumulation of  $\gamma$ -exposure with time is shown in Figure 1.

Nuclide	ERL ( $\mu\text{Ci}/\text{m}^2$ )	Release (Ci)
Sr-89	190	4.9
Sr-90	6.6	0.46
Ru-103	-	760
Ru-106	-	280
I-131	1.8	550
Cs-134	11	34
Cs-137	18	60

TABLE 1: Derived ERLs for ground contamination\*, and activities of main nuclides released.

\* From Reference 1, except for Cs-134.

Criterion	Route	Downwind (km)	Area (ha)
30 rem Lung	Inhalation <sup>†</sup>	0.72	5.2
30 rem Thyroid		0.60	3.6
30 rem Thyroid	Milk <sup>†</sup>	8.3	460
10 rem Whole Body		0.65	4.3
10 rem Bone marrow		0.06	0.05
15 R $\gamma$ -exposure	Ground- $\gamma$	0.52	2.8
Same, Cs-137 only		0.35	1.4

<sup>†</sup> Dose to 6 months old child

TABLE 2: Extent of areas where ERLs may be exceeded.

The calculated areas fall into three groups. The largest area is for an ERL of I-131 through milk. Secondly, the areas for caesium isotopes through milk,  $\gamma$ -irradiation from the ground, and the early inhalation hazard are all roughly similar in size. Finally, strontium contamination is relatively limited in extent. In some circumstances higher rates of deposition can be expected, increasing the importance of ground contamination relative to inhalation doses. For example, if the deposition velocity is raised to 10 mm/s, the area contaminated above the ERL for  $\gamma$ -exposure is increased by

a factor of three, and a similar increase results from the addition of fallout at the fractional rate of  $1/10^4$  per second.

In this example, the  $\gamma$ -irradiation from the ground is of special interest, because it is the only predicted source of significant dosage that is not effectively avoided by emergency action based on temporary evacuation and the control of food supplies. It is mainly of concern in areas where frequent access is required by a large number of people, and would be of particular relevance if a release from an urban sited reactor led to the contamination of neighbouring industrial plant. In this case, large-scale decontamination might be required in order to restore safe working conditions.

The principal conclusion to be drawn from this work is that a release of fission products from a reactor can lead in the long term to  $\gamma$ -ray doses from the ground that are comparable in significance with the initial inhalation hazard, if no countermeasures are taken. Accidents in which other long-term effects would become important are less readily envisaged.

ACKNOWLEDGMENT This paper is published by permission of the Central Electricity Generating Board.

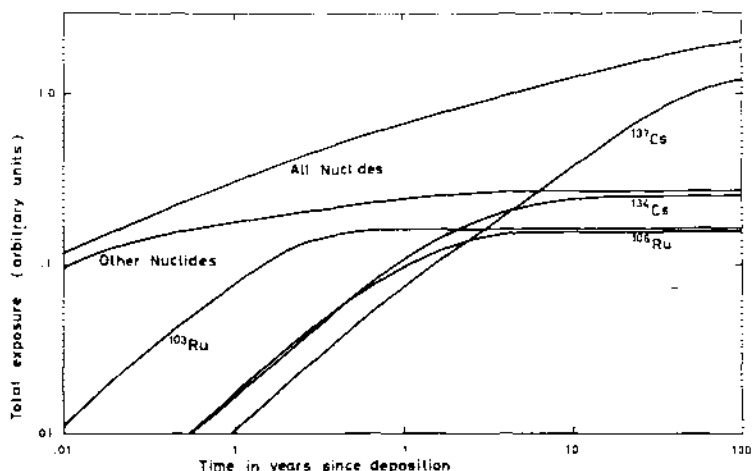
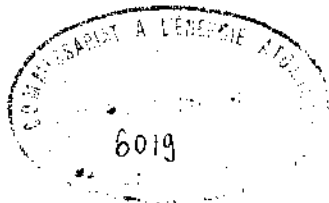

FIG. 1. Accumulation of  $\gamma$ -Ray Exposure with Time.

#### REFERENCES

1. MEDICAL RESEARCH COUNCIL, "Criteria for controlling radiation doses to the public after accidental escape of radioactive material", HMSO, London (1975).



2. J.R. BEATTIE, "Radiological significance of caesium 137 releases from Mark II and Mark III gas-cooled reactors", AERE Report No. SRD R11 (1972).
3. J.O. CORBETT, "The significance of ground contamination following an accidental release of radioactivity", CEGB Report No. RD/B/N3865, (1977).
4. W.G.N. SLINK, "Some aspects of the resuspension problem", BNWL Report No. BNWL-1930, Part III (1975) 199.



EVALUATION DES RISQUES PRESENTES PAR LES TRANSPORTS DEMATIERES RADIOACTIVES - CAS DE L'UF6

P. MAITRE - T. MESLIN - P. PACÈS - A. RAGGENBASS

Commissariat à l'Energie Atomique  
DPE/LSEES

B.P. n° 6 92260 Fontenay-aux-Roses, France

-:-:-:-:-:-:-:-:-:-:-:-

## 1. INTRODUCTION - RESUME

L'étude sur l'évaluation des risques présentés par le transport des matières radioactives est une tentative pour aborder ce problème dans l'optique d'une minimisation de l'exposition du public, compte tenu des contraintes socio-économiques, telle que la préconise la C.I.P.R. dans sa publication n° 22.

Un modèle visant à évaluer la sûreté des transports et permettant de suggérer un certain nombre de mesures de protection supplémentaires est créé ; et utilise en particulier certaines méthodes statistiques telles que l'analyse des données ou les arbres d'événements.

Dans un premier temps, on applique ce modèle au cas du transport de l'Hexafluorure d'Uranium.

## 2. PRESENTATION DU PROBLEME - OBJECTIFS

L'objectif général de l'étude consiste à mettre au point un outil et une méthode applicable à tous les types de transport et s'inscrivant dans le cadre de l'évolution de la sûreté des transports de matières radioactives.

Cet objectif revêt plusieurs aspects : analytique, prévisionnel et décisionnel.

On vise en effet à fixer la connaissance des risques liés aux accidents dans les différents modes de transports utilisés.

Il s'agit de décrire les différents accidents pouvant survenir et d'évaluer le risque associé à l'aide d'indicateurs pertinents.

A l'aide des résultats ainsi obtenus et en tenant compte de l'évolution des transports dans les prochaines années, on est en mesure de proposer certaines politiques de protection raisonnablement envisageables compte tenu des contraintes techniques et de discuter de leurs efficacités relatives.

## 3. METHODOLOGIE

Compte tenu des objectifs fixés, nous nous proposons d'élaborer un modèle physique qui permette d'évaluer au mieux le risque sur la base des données et des techniques effectivement disponibles. Une phase préliminaire d'analyse du système des transports met en évidence les variables pertinentes entrant dans le modèle : trafic, mode de transport, type de conteneur, parcours, etc... (cf. fig. 1).

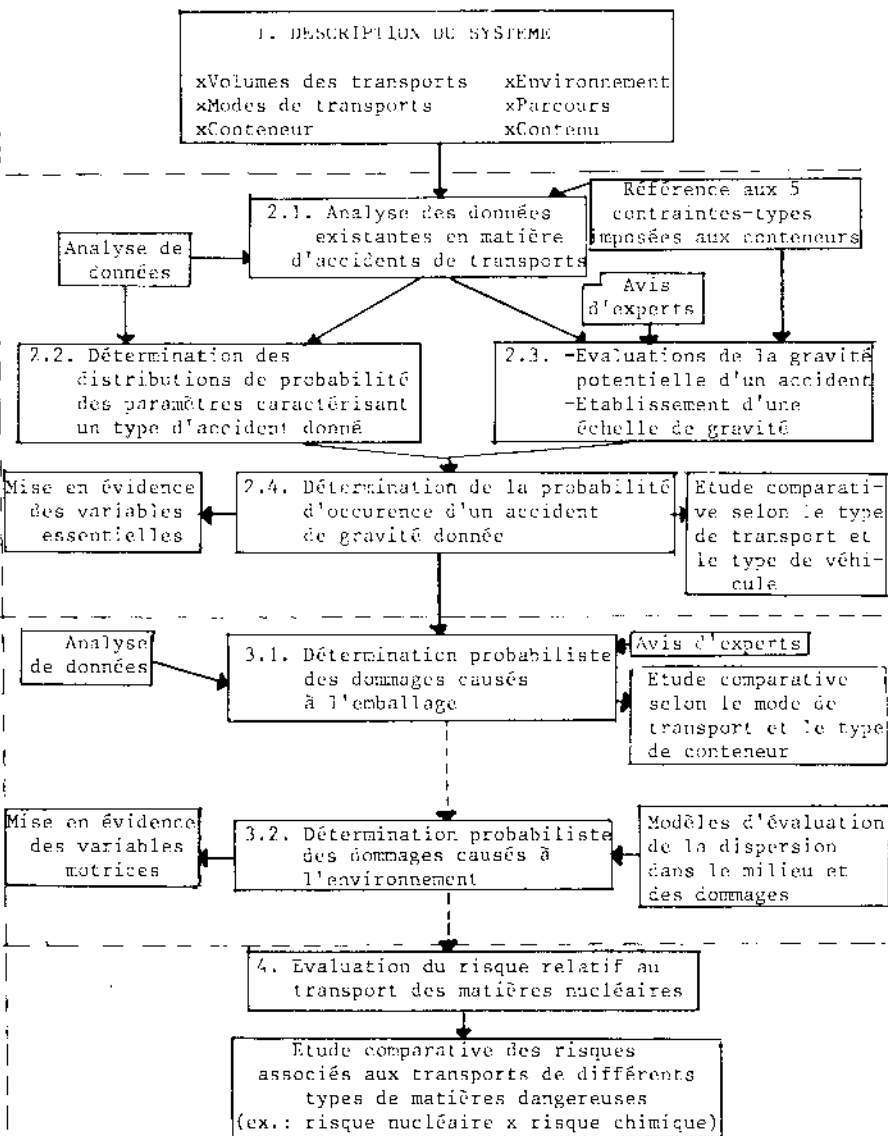

FIGURE 1 : ORGANIGRAMME FONCTIONNEL DE LA METHODE

Les données statistiques à la base de cette étude sont essentiellement celles des fichiers d'accidents (route, chemin de fer) obtenus auprès du Ministère des Transports, de la SNCF, de la Direction de la Protection Civile.

Le problème de l'évaluation du risque à partir de ces fichiers est décomposé en trois étapes au cours desquelles, outre les techniques classiques d'analyse statistique des données, on fait appel en particulier à la technique des arbres de défaillances ou d'événements (représentation schématisée déductive d'une séquence d'accidents).

### 3.1. La description du processus accidentel

Le but est de déterminer successivement pour un mode de transport donné (une catégorie de véhicule, un type de conteneur, un parcours) :

- la probabilité d'occurrence d'un accident (quelconque)
- la probabilité, sachant qu'un accident est survenu, qu'il soit d'un certain type (feu, collision...) et d'une certaine "gravité".

### 3.2. L'évaluation des conséquences

Elle correspond à l'estimation des quantités suivantes :

- la probabilité qu'un accident d'une certaine gravité potentielle occasionne pour le conteneur des dégâts de niveau donné, c'est-à-dire en particulier, donne lieu à une ouverture du conteneur.
- la probabilité, connaissant les conditions d'ouverture du conteneur, de relâchement dans l'environnement d'une certaine quantité de matière radioactive
- la probabilité que ce relâchement occasionne des dommages et finalement un détriment donné.

### 3.3. L'évaluation du risque

L'expression du risque est la somme des conséquences ( $C_i$ ) pondérées par les probabilités associées ( $P_i$ )

$$R = \sum_i P_i C_i$$

## 4. RESULTATS - APPLICATION AU CAS DE L'UF6

Les résultats actuellement disponibles ne portent que sur la première phase de l'élaboration du modèle et sont propres aux accidents routiers et ferroviaires.

Les paramètres décrivant les efforts subis par les conteneurs et permettant d'analyser la gravité de l'accident sont choisis en fonction des tests de résistance fixés par l'AIEA : Impact, Ecrasement, Perforation, Feu et Immersion.

Nous obtenons des distributions de probabilités de différents paramètres exprimés à l'aide d'indicateurs physiques que sont l'énergie mise en jeu, la vitesse, la durée du feu...

L'analyse des données, en particulier, des conséquences des accidents, nous permet d'une part d'obtenir des échelles de gravité en 5 points pour chacun des paramètres et d'autre part une agrégation des 3 paramètres propres au choc.

Enfin, on étudie le comportement des citernes industrielles dans différentes situations d'accidents de transport, ce qui permet d'extrapoler au comportement de certains conteneurs de matières radioactives face aux mêmes contraintes.

Le travail est effectué pour le transport de l'Hexafluorure d'Uranium, en tenant compte des trafics actuels et futurs (1980), des modes de transports (1er et route), de la nature du conteneur (citerne industrielle de 14 t) et de la spécificité de l'UF<sub>6</sub> quant à sa nature chimique.

La supériorité du Chemin de fer sur la route est démontrée, particulièrement vis à vis des risques d'incendie, lesquels par ailleurs se sont révélés être les plus redoutables dans le cas de l'UF<sub>6</sub>.

#### 5. CONCLUSION - PERSPECTIVES

La mise au point d'un tel modèle est une étape décisive dans la connaissance des risques en matière de transports.

L'étude de l'UF<sub>6</sub> constitue la première application de ce travail, et déjà une étude plus systématique de l'ensemble des transports nucléaires est en cours, en même temps que de nouvelles données doivent permettre d'enrichir le modèle et d'affiner ses résultats.

--:--:--:--:--:--:--:--:--

## EXTERNAL RADIATION EXPOSURE OF THE PUBLIC

Comparison of contributions  
from  
nuclear power stations, nuclear research centers and dwelling houses  
in  
the Federal Republic of Germany

J. Mehl  
Federal Ministry of Interior, Bonn

## 1. INTRODUCTION

In order to keep releases of radioactive substances in air and water from nuclear power stations "as low as practicable" a dose limit of 5 mrem per year to critical groups of the population was proposed for planning purposes by the USAEC (1) in 1971. Since then similar restrictive standards have been established by other countries including the Federal Republic of Germany (2) and considerable efforts are made involving high costs for design, construction, operation, maintenance and inspection as well as for administrative control to meet these standards.

Where such restrictive standards apply proper sense of perspective may be questioned unless the same attention is paid to all cases where either doses originating from other activities of man may exceed 5 mrem per year to a critical group or where groups larger than a critical group may receive doses in the order of 5 mrem per year.

In the following contributions to external radiation exposure of the public from nuclear power stations, nuclear research centers and dwelling houses in the Federal Republic of Germany are compared in order to provide a basis for judgement.

## 2. NUCLEAR POWER STATIONS AND NUCLEAR RESEARCH CENTERS

Annual (1972-1975) releases of radioactive noble gases in air from nuclear power stations and nuclear research centers (3, 4, 5) are listed in table 1. The annual doses from external gamma-radiation in the environment of the Gundremmingen nuclear power station in 1973 (6) are shown in figure 1. In spite of the higher than normal release in 1973 (due to fuel element leakage) offsite doses are well below 5 mrem per year and well below 1 mrem per year in occupied regions. The doses apply to the unprotected man staying the full time of a year at points for which the dose values are given.

The annual doses from external gamma-radiation in the environment of the Karlsruhe research center (5) are shown in figure 2. The gamma-doses are primarily due to a fairly constant release of about  $10^5$  Ci/a Ar-41. The larger values of annual releases of noble gases given in table 2 are mainly due to larger variation of Kr-85 releases which have no effect on the gamma-dose. The dwelling house nearest to the center is an isolated forester's house at a distance of about 2 km northern the central point. The annual gamma-dose at this point is well below 2 mrem per year. At the nearest

house of a village south-west of the central point the external gamma-dose is also below 2 mrem per year.

A detailed list of the maximum annual doses in the environment of nuclear power stations and nuclear research centers of the Federal Republic of Germany (7) is given in table 2. The doses apply to an unprotected man or child staying full time of a year at the most unfortunate point even though this place is in fact unoccupied in all cases.

From these data it becomes obvious that the maximum effective dose due to external gamma radiation from releases of radioactive substances in air from nuclear installations of the Federal Republic of Germany to individual members of the public is well below 1 mrem per year.

The total annual collective doses from operation, maintenance and repair, and inspection received by local and contractor staff in nuclear power stations of the Federal Republic of Germany are listed in table 3 (8). The average annual collective dose per station is about 500 manrem per year.

### 3. DWELLING HOUSES

In 1972 the Federal Ministry of Interior initiated large scale measurements of gamma-doses inside and outside dwelling houses. The primary objective of these measurements was to receive information on the effect of radioactivity in building material on the doses received by individuals and by the general public. This survey was supplemented by numerous analyses of building materials concerning the radionuclide composition and concentration.

In the following the term "excessive dose" is used for the difference  $D_i - D_e$ , where  $D_i$  is the dose measured in living rooms of a house and  $D_e$  is the dose measured outside the house. Positive values of the excessive dose are obtained if  $D_B > D_e (1 - 1/n)$ , where  $D_B$  is the dose contribution to  $D_i$  from sources in the building material used for construction of the house and  $1/n$  is the fraction of  $D_e$  left as a contribution to  $D_i$  from sources outside the house.

In table 4 are listed the arithmetic averages of all excessive doses found in each of the 11 states and city states of the Federal Republic of Germany (see fig. 3), the population of each state and the contribution of the excessive doses to the collective dose of the population of each state. The data are based on about 30 000 measurements in houses and about 25 000 measurements outside houses (9). The average excessive dose is highest in the Saarland (36.4 mR/a) followed by Rhineland-Palatinate (30.5 mR/a) and Hesse (25.9 mR/a). The lowest values were found in Hamburg (0.46 mR/a) and Slesvig-Holstein (2.6 mR/a). The effect of the excessive doses of the various states to the weighted mean excessive dose of the population as a whole (15.86 mR/a) can be seen from the contributions of each state to the collective dose. Comparison of these contributions to the collective dose with the contributions to the collective doses from workers of nuclear power stations (see table 3) may be of interest.

The states and city states are for administrative purposes divided into 559 urban and municipal districts. In order to provide more detailed information

on the distribution of the excessive doses the average excessive doses of these districts is shown in figure 4. The density of values covering the area of the Federal Republic of Germany permits the identification of isodose areas. The values listed in figure 4 are the average excessive doses in mR/a which apply to the respective area. The highest value (75 mR/a) applies to a region near Koblenz where extensive use of pumice stone for house construction is made, followed by a region near Saarlouis (50 mR/a) where extensive use of slag stone is made. The population of the Saarlouis district is 207 000 but there are other districts in the Saarland where the excessive dose is nearly as high with a population of several 100 000. The situation in the region near Koblenz is very similar, in this case the high excessive doses apply to districts with a population of 500 000. In some regions east from the Bavarian forest at the border line to Czechoslovakia where the doses outside of houses are fairly high (up to 130 mR/a) negative values of the "excessive dose" are obtained, this means that, in general, in these regions the shield-effect of the house walls is larger than the effect of the radioactive substances in the material used for house construction. Similar effects have been observed in some urban districts where the dose measured outside houses was high when basalt was used for the construction of streets. Therefore, the monitors were instructed to perform measurements outside houses above natural ground and in due distance from houses and roads.

It should be noted that all excessive doses referred to so far have still been averages over population groups of at least 10 000 persons, so that there is still left the answer to the question concerning the maximum excessive dose to individuals in one dwelling house. The largest value reported so far is 600 mR/a. The house was constructed by its owner using slag from a (phosphate-) fertilizer producing factory, where he was employed. More frequently excessive doses up to 300 mR/a have been found. The number of such cases is certainly higher than the number of cases where individuals may receive a dose of the order of 1 mrem/year from the release of radioactive substances in air from nuclear installations.

#### 4. CONCLUDING REMARKS

From a detailed analysis of the results obtained from dose-measurements in dwelling houses of different age in the Saarland it was found that in houses constructed since 1900 the gonad dose is in the average 25% higher than in houses built before 1900. This corresponds to an increase of the gonad dose by 18 mrem per year and is primarily due to the increasing use of slag stones for house construction in this region. It should also be mentioned that in a dwelling house where walls were lined with uranium glazed flagstones a beta-dose rate of 1.5 mR per hour was measured (10) and that in this paper no reference is made to the additional internal doses from radon emanating from radium in building material.

I should now leave the decision to you, where in your country efforts aiming at the reduction of radiation doses from activities of man to levels as low as practicable should be increased, if doses of this order of magnitude are considered to be of real concern!

## 5. REFERENCES

- 1 ) USAEC  
Proposed rule making  
Federal Register, Vol. 36, No. 111, June 1971
- 2 ) Federal Ministry of Interior  
Radiation Protection Ordinance  
BGBl I, 2905-2995, 1976
- 3 ) Winkelmann, I. Endrulat, H. J. , Haubelt, R. , Westpfahl, U.  
Summary of data on the release of radioactive substances in air from  
nuclear power stations in the Federal Republic of Germany  
Report STH-2/76, Federal Bureau of Health, Neuherberg/München
- 4 ) Vogt, H. J. , Heinemann, K.  
Release of radioactive substances and radiation exposures at the  
nuclear research center Jülich  
1972: Report ZSt 170/1973                    1974: Report ZSt 209/1975  
1973: "        ZSt 189/1974                    1975: "        ZSt 231/1976  
Nuclear research center Jülich
- 5 ) Kiefer, H. , Koelzer, W.  
Annual report of the division of radiation protection and safety  
1972: Report KFK 1818/1973                    1974: Report KFK 2155/1975  
1973: "        KFK 1973/1974                    1975: "        KFK 2266/1976  
Nuclear research center Karlsruhe
- 6 ) Huber, O. , Eickelpasch, N.  
Radiation exposure in the environment from the release of radioactive  
substances in air from the nuclear power station Gundremmingen  
Report STH-3/75, Federal Bureau of Health, Neuherberg/München
- 7 ) Federal Ministry of Interior  
Environmental radioactivity and radiation exposure - Annual reports  
1973 and 1974  
Federal Ministry of Interior, Bonn
- 8 ) J. Mehl  
Radiation exposure of radiation workers in nuclear power stations of  
the Federal Republic of Germany (1968-1976)  
Report RSII3/1977, Federal Ministry of Interior, Bonn
- 9 ) Federal Ministry of Interior  
Exposure of the public from natural sources  
Report        /1977, (in print), Federal Ministry of Interior, Bonn
- 10) Ludwig, F. , Kunz, H.  
Radioactivity and radiation exposure from uranium glazed flagstone  
lining of walls  
Proceedings of the 8<sup>th</sup> Annual Meeting of the Fachverband für Strahlen-  
schutz, Helgoland, 1974



Table 1:

Release of radioactive noble gases from nuclear power stations  
and nuclear research centers of the Federal Republic of Germany

A Nuclear power stations

Station	1972 Ci/a	1973 Ci/a	1974 Ci/a	1975 Ci/a
Kahl	-	480	1 000	380
Gundremmingen	11 000	23 500	4 200	7 400
Lingen	5 100	2 600	9 500	35 200
Obrigheim	3 200	2 900	14 000	8 000
Stade	2 450	2 600	900	1 300
Würgassen	590	560	50	120
Biblis A	-	-	50	1 700

B Nuclear research centers

Center	1972 Ci/a	1973 Ci/a	1974 Ci/a	1975 Ci/a
Karlsruhe	213 500	131 300	103 000	139 200
Jülich	460	970	1 400	720

Table 2:

Maximum annual doses from releases of radioactive substances in air in the environment of nuclear power  
stations and nuclear research centers of the Federal Republic of Germany (1974)

Station	$\gamma$ -submersion	$\beta$ -submersion	iodine-inhal.	iodine-ingest.	average gonad dose	average gonad dose
	mrem/a	mrem/a	mrem/a (child)*	mrem/a (child)*	mrem/a 0 - 3 km	mrem/a 0 - 20 km
<u>A Nuclear power stations</u>						
Kahl	0.2	0.09	0.001	0.3	0.004	< 0.001
Gundremmingen	0.7	0.2	0.02	7	0.02	0.004
Lingen	0.7	0.09	< 0.001	0.003	0.03	0.003
Obrigheim	0.6	2.6	0.001	2.7	0.02	0.003
Stade	0.01	0.01	0.001	0.4	< 0.001	< 0.001
Würgassen	0.02	0.02	0.001	0.3	< 0.001	< 0.001
Biblis A	< 0.001	< 0.001	< 0.001	0.002	< 0.001	< 0.001
<u>B Nuclear research centers</u>						
Center						
Karlsruhe	13	3.7	0.025	55	< 0.45	< 0.1
Jülich	0.4	0.3	0.25	35	< 0.2	< 0.02

\* Critical pathway: grass - cow - milk - child (assumed but not valid)

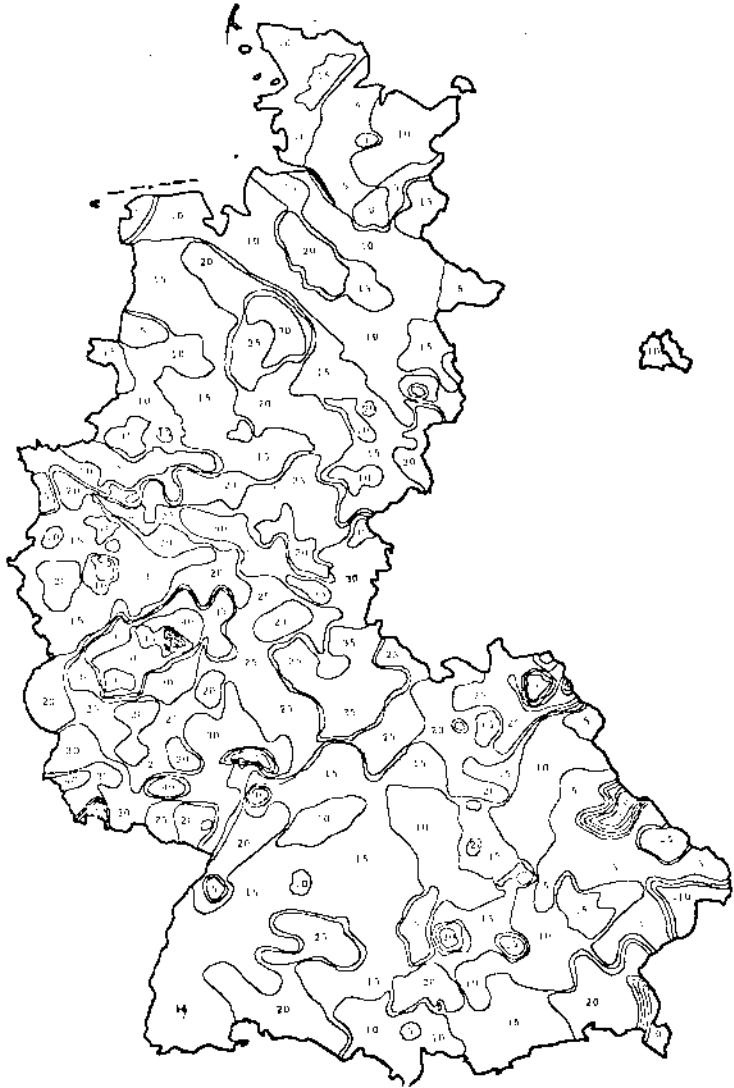

Fig. 4: Results of gamma-dose measurements inside ( $D_i$ ) and outside ( $D_e$ ) houses: District averages of the excessive dose ( $D_i - D_e$ ) in mR/a

VARIATIONS DE LA DOSE DUE A L'IRRADIATION NATURELLE  
DANS LA REGION PARISIENNE

J.M. Guézengar, A. Bouville, C. Madelmont  
Département de Protection - Service de Protection Sanitaire  
COMMISSARIAT A L'ENERGIE ATOMIQUE  
R.P. 6 - 92260 FONTENAY AUX ROSES (FRANCE)

### 1. INTRODUCTION

Une campagne d'évaluation de l'irradiation externe d'origine naturelle à laquelle sont soumises les populations a été effectuée à Paris et dans les départements limitrophes ainsi que dans les départements de l'Essonne, du Val d'Oise et des Yvelines, pendant une période de trois mois. Cette étude a été réalisée en liaison avec les Services de la Météorologie Nationale et n'a pu être menée à bien que grâce à la collaboration bénévole de leurs correspondants.

Une seconde campagne de mesures, portant sur une période d'un an (de décembre 1975 à novembre 1976), a été effectuée afin de comparer les résultats de deux types de dosimètres ( $^{90}\text{Sr}$  et  $\text{LiF}$ ), d'estimer les erreurs que pourraient apporter les variations climatiques et la durée d'exposition, enfin d'évaluer l'influence de la hauteur du point de mesure.

### 2. MOYENS ET METHODES

La mesure des doses d'irradiation externe a été faite durant la première campagne au moyen de dosimètres radiothermoluminescents au sulfate de calcium qui se présentaient sous la forme de petits cylindres d'environ 2 cm de longueur et de 0,5 cm de diamètre, enfermés dans un étui en matière plastique. Chaque dosimètre était accompagné d'un questionnaire fournissant divers renseignements sur le lieu d'implantation et son environnement.

Sur 300 dosimètres distribués, tant aux correspondants de la Météorologie qu'à un certain nombre d'agents du C.R.A., 263 ont pu être récupérés ; 98 avaient été placés à l'extérieur des habitations et 165 à l'intérieur des habitations.

Dans la deuxième campagne 40 dosimètres au fluorure de lithium et 240 dosimètres au sulfate de calcium ont été répartis en 11 points pour des durées d'exposition de 2, 4 et 6 mois.

### 3. RESULTATS OBTENUS : PREMIERE CAMPAGNE DE MESURES

#### - Dosimètres placés à l'extérieur des habitations

La distribution des doses enregistrées par les dosimètres placés à l'extérieur des habitations est représentée sur la figure 1 (courbe A) ; elles varient entre 46 et 102 millirads par an ; l'histogramme obtenu peut être assimilé, sans trop d'erreur, à une courbe "normale". Les doses absorbées par ces dosimètres représentent l'irradiation totale et tiennent par conséquent compte :

- de l'irradiation due au rayonnement cosmique dont la variation pour ces différents lieux (en fonction d'une altitude variant de 20 à 200 m) est très faible, et peut être considérée égale à 30 millirads par an ;

- de l'irradiation tellurique qui dépend de la nature géologique du sous-sol : le bassin parisien, de formation tertiaire non affectée ou conditionnée par l'orogénèse pyrénéo-alpine, est a priori peu radioactif ;
- de la radioactivité artificielle due essentiellement aux retombées des essais nucléaires atmosphériques, dont l'importance est négligeable devant les composantes de l'irradiation naturelle. Ces résultats sont évidemment influencés par l'environnement immédiat du dosimètre (proximité d'un mur en pierre, d'un trottoir asphalté, etc.).

#### - Dosimètres placés à l'intérieur des habitations

Les doses absorbées par les dosimètres placés à l'intérieur des habitations sont influencées par la nature des matériaux de construction ; elles varient entre 44 et 164 millirads par an et leur distribution (figure 1 - courbe B) est ajustée par une courbe "log. normale".

### 4. RESULTATS OBTENUS : DEUXIEME CAMPAGNE DE MESURES

#### - Comparaison des types de dosimètres

En chaque emplacement un dosimètre au sulfate de calcium et un dosimètre au fluorure de lithium ont été exposés pour deux périodes de six mois, la comparaison des résultats ne fait pas ressortir de différences statistiquement significatives dans les valeurs obtenues. Les moyennes des doses enregistrées ont été de 66 et 67 millirads par an respectivement pour les dosimètres au sulfate de calcium et les dosimètres au fluorure de lithium. Les deux types de dosimètres donnent par conséquent des résultats équivalents. Les dosimètres au  $CaSO_4$  peuvent être utilisés pour une étude ultérieure éventuelle parce qu'ils sont plus sensibles que les dosimètres au  $LiF$  et permettent par conséquent des temps d'exposition plus courts.

#### - Effets de la période d'exposition

En vue d'estimer les erreurs que pourraient apporter les variations climatiques, les résultats obtenus pour 6 périodes successives de 2 mois d'exposition ont été comparés. Une différence significative de l'ordre de 13 % n'a été observée que pour les périodes d'exposition de juin-juillet et d'octobre-novembre, les valeurs obtenues étant moins élevées.

Bien que la première de ces deux périodes soit marquée par des conditions climatiques particulières (température et durée totale d'insolation exceptionnellement élevées) une hypothèse ne peut être écartée : le développement des dosimètres a eu lieu au mois d'août dans des conditions de lecture inhabituelles. La seconde période, octobre-novembre, a été caractérisée par un nombre de jours de pluie important et la saturation en eau du sol peut expliquer que les doses enregistrées soient plus faibles.

#### - Effets de la durée d'exposition

La comparaison de l'influence de la durée d'exposition a également été étudiée. L'écart le plus important est obtenu en comparant les résultats des dosimètres restés 6 mois et la somme des résultats des 3 dosimètres restés en place 2 mois chacun : la différence est en moyenne de 5 %, le résultat le moins élevé étant celui obtenu pour les dosimètres ayant subi une exposition de 6 mois. A titre de comparaison l'écart moyen entre les résultats des dosimètres exposés 4 mois et la somme des résultats des 2 dosimètres restés en place 2 mois chacun est de 3 %. Ces différences peuvent être expliquées par la présence à la lecture d'un bruit de fond de l'appareillage dont l'influence est

d'autant plus grande que la dose à mesurer est plus petite donc que l'exposition est plus courte.

#### - Effets de la hauteur du point de mesure

Sur 3 des 11 points d'exposition les dosimètres ont été placés à des hauteurs différentes (0,5 m - 1 m - 1,50 m et 2 m) dans le but d'étudier l'influence de la hauteur du point de mesure. Les moyennes enregistrées dans ces 3 emplacements sont, toutes hauteurs confondues, de 61, 71 et 93 millirads par an. Dans les deux premiers emplacements les différences observées ne sont pas statistiquement significatives, mais dans le troisième emplacement, où les valeurs observées sont les plus élevées, les différences sont significatives et l'écart enregistré entre les doses absorbées par les dosimètres placés à 0,50 m et celles observées par ceux placés à 2 m sont de 10 %. Cela peut être dû à l'hétérogénéité de la contamination du sol en cet endroit.

#### 5. CONCLUSION

Les résultats obtenus au cours de la première campagne permettent de voir que les moyennes arithmétiques des doses absorbées par les dosimètres placés à l'extérieur et à l'intérieur des habitations sont pratiquement identiques et égales à 73 millirads par an. Ce résultat est très comparable à l'estimation de la moyenne mondiale (80 millirads par an). Il faut également noter que l'influence des matériaux de construction se fait sentir par une plus grande variabilité des résultats obtenus à l'intérieur des habitations.

Les résultats obtenus au cours de la seconde campagne permettent de noter que les dosimètres au sulfate de calcium donnent les mêmes résultats que les dosimètres au fluorure de lithium, mais il peuvent être utilisés de préférence étant donné leur sensibilité. Les variations saisonnières sont inférieures à 10 %. L'influence de la durée d'exposition se traduit par un écart de 5 % pour une exposition de 2 à 6 mois et de 3 % pour une exposition de 2 à 4 mois. Ces différences, inférieures à l'incertitude qu'apporte l'erreur de lecture des dosimètres, peuvent être utilisées comme facteurs correctifs tenant compte de la durée d'exposition. La variation enregistrée en fonction de la hauteur du point de mesure n'est pas sensible pour 2 emplacements, pour le troisième elle est de 10 % entre 0,50 m et 2 m.

Ces études ont pu être menées à bien grâce à l'appui des équipes dirigées par MM. MONET (Laboratoire de surveillance atmosphérique - CEN/Saclay), FAGES (Laboratoire de statistiques et d'études économiques et sociales - CEN/Fontenay-aux-Roses), PORTAL (Section technique d'instrumentation et de dosimétrie - CEN/Fontenay-aux-Roses).

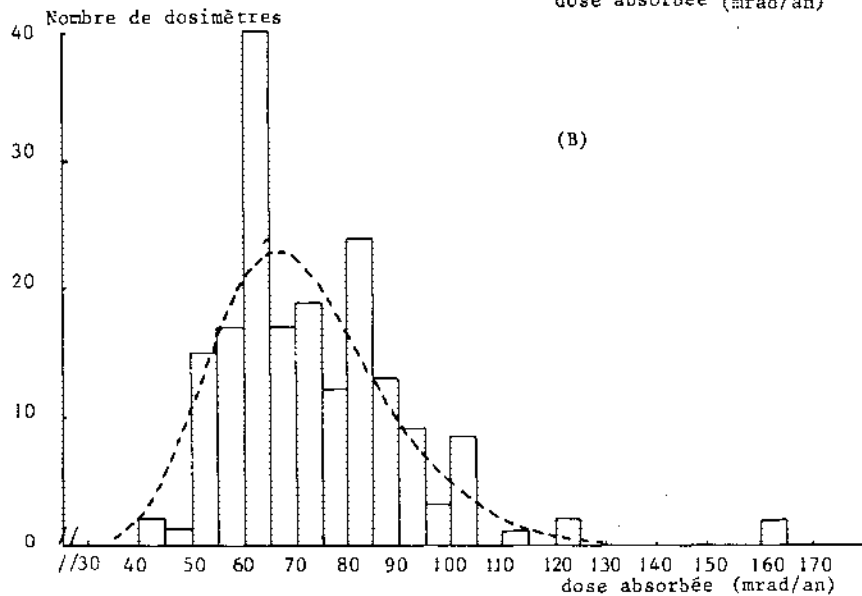
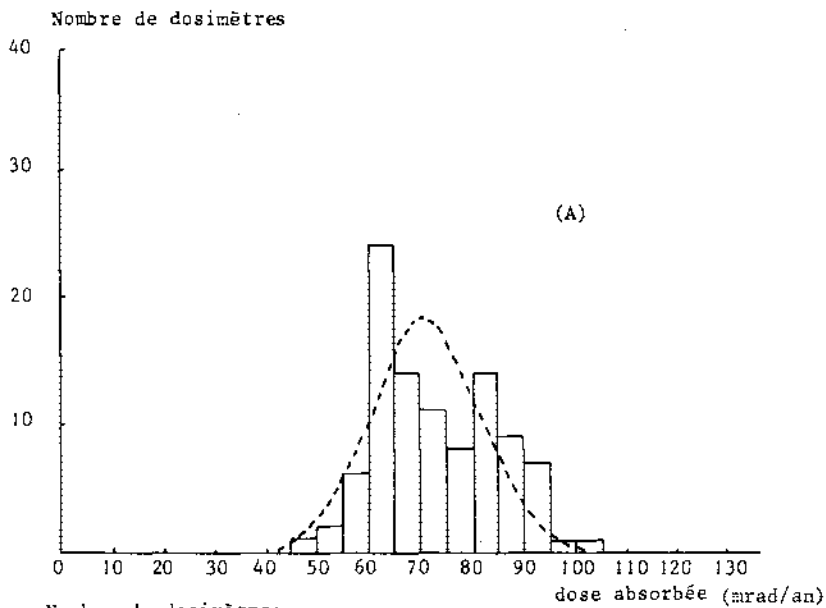

Figure 1 - Distribution des doses absorbées par les dosimètres placés dans la région parisienne à l'extérieur (A) et à l'intérieur (B) des habitations.

RADIATION LEVELS FROM NATURAL SOURCES  
IN THE ADULT POPULATION OF BAGHDAD

S. A. M. Al-Hashimi

N. S. Al-Banna

Atomic Energy Commission  
Nuclear Research Institute  
Health Physics Department  
Tuwaitha, Baghdad,

## 1. INTRODUCTION

The bulk of the natural radiation to which human are exposed is generated by  $^{40}\text{K}$  and  $^{226}\text{Ra}$  and decay daughters of the last element. These radio-nuclides have always been present in human body and its environment in low but variable concentrations.

The body burden in human resulting from environmental materials, has been considered by many investigators (1-5).

An evaluation of the total body Dose-Equivalent received, requires measuring the concentration of those corporations present in both human body and environment.

This paper also presents the results of studies on natural background radiation dose values to which Baghdad population are exposed.

## 2. METHODS

### 2.1. Body Radioactivity Measurements

The measurements of  $^{40}\text{K}$  and  $^{226}\text{Ra}$  content of man were carried out in the conventional iron room equipped with 23 cm dia x 10 cm thick NaI(Tl) crystal and analyzer (6). The phantom calibration of the whole-body counter for  $^{40}\text{K}$  and  $^{226}\text{Ra}$  was carried out regularly before each set of measurements.

### 2.2 Environmental Radioactivity Measurements

Environmental samples were collected weekly from different sites of Baghdad City.

Water samples were evaporated to minimum volume and also sealed to prevent

losses of radon.

The same vessels with calibrated amounts of  $^{40}\text{K}$  and  $^{226}\text{Ra}$  were used as a measured standards. The scintillation detector employed was well-type NaI(Tl), 5 cm dia x 6 cm deep crystal.

Samples of aerosol were also regularly collected. Each filter paper was sealed in a suitable container to achieve an equilibrium.

Measurements were performed three weeks after sampling to ensure equilibrium of the decay chain. The standard time of measurement was equal to 4000 sec.

The natural radioactivity content was determined through the peak at 1.46 MeV of  $^{40}\text{K}$  and 1.76 MeV of  $^{214}\text{Bi}$  for potassium and radium respectively.

### 3. RESULTS AND DISCUSSION

Using the methods described, we measured about 1200 males and females, 11 to 60 years of age. Normal students and professionals were selected in three groups according to their life conditions.

Calculations were made to establish equations for predicting body K in gK/Kg as a function of age and weight with an error of about  $\pm 6\%$  :-

$$\begin{aligned} &= 2.51 - 0.0178 \times \text{Age (yr)} \\ \text{(male)} &= 2.95 - 0.0150 \times \text{Weight (Kg)} \\ &= 2.23 - 0.0217 \times \text{Age (yr)} \\ \text{(female)} &= 2.71 - 0.0179 \times \text{Weight (Kg)} \end{aligned}$$

No correlation was found to exist between K and height. These results are agreed with data reported in (7,8). A representative normal K body content is about 0.19% and 0.16% in males and females respectively. The total body activity is 0.12  $\mu\text{Ci}$ , therefore, the total dose per yr in the majority will be about 20 mrem. However, these data are comparable to those in the literature (9,10).

The concentration of  $^{226}\text{Ra}$  by sex and age in decades was also measured. The obtained range was found to be 0.00-2.80 n Ci/Kg bone. The inter-quartile range 0.00-0.90 n Ci/Kg and the mean value  $\pm$  standard deviation



was  $0.151 \pm 0.182$  and  $0.226 \pm 0.313$  n Ci/Kg for male and female respectively. These figures are comparatively high relative to the data given in the literatures (1,11,12). The levels reported here are of the same order of magnitude for human skeleton reported for sites having high  $^{226}\text{Ra}$  concentration (11). We can give no explanation for the high  $^{226}\text{Ra}$  content in females skeletal, except the wide deviation of measuring. The concentration of  $^{226}\text{Ra}$  was not significantly correlated with age in either sex.

The average Dose-Equivalent for  $^{226}\text{Ra}$  may be expressed by the modified Spiers and Burch equation (1). It was found that the Dose-Equivalent in the mixed population presented in this study was 123 and 184 mrem/yr for male and female respectively. These figures are significantly higher than those reported for the countries with normal natural radioactivity (1,13).

The other side of this study has been made to obtain some data on the transfer of radionuclides through different environmental means.

The contribution of drinking water to the  $^{226}\text{Ra}$  intake was averaged as 3.8 p Ci/li. This figure is approximately high when compare with the data for Germany (0.03-0.34 p Ci/li) (14), but it appears average (0-5.8 p Ci/li) if compared with the data for USA (11,15).

The aerosol concentration of  $^{226}\text{Ra}$  per unit weight was also reported as  $(0.27-3.3) \times 10^{-4}$  p Ci/li which is about 0.033% lower if compared with the values assumed by ICRP, 1959.

The mean air dose-rate at 1 m above the ground was calculated for different sites to yield a value of 20 uR/hr. A value of 5 uR/hr thus obtained for the cosmic ray contribution was also included, which were very close to the values reported (3,13).

Therefore, the calculated total annual Dose-Equivalent values due to naturally occurring radionuclides in the body was about 200 mrem, and external radiation of 175 mrem.

#### 4. CONCLUSIONS

We have outlined in this paper the suitability of measuring the content of some radionuclides in the human body. Even though the data given is

rather scanty, it seems, however, possible to give a preliminary figure of Dose-Equivalent to which the population naturally exposed.

Observing the given data, it can be noted that they are rather high if compared with the values assumed by the current ICRP, 1959 permissible levels.

#### REFERENCES

- (1) SPIERS, F.W., " Radioisotopes in the human body", Academic Press, 1968.
- (2) OSBURN, W.S., Health Phys. 11, 1275 (1965).
- (3) DE BORTOLI M.C. and GAGLIONE P., Health Phys. 17, 701 (1969).
- (4) BORIVOVJ HAVLIK, Health Phys. 19, 617 (1970).
- (5) CHANG, T.Y. et al., Health Phys. 27, 385 (1974).
- (6) AL-HASHIMI, S. et al., 1st. Asian Regional Congress on Radiation Protection, Bombay (India), 15-20 Dec. (1974).
- (7) HUGHES, D. et al., Clini. Sci. 32, 503 (1967).
- (8) DELWAIDE, P.A., Int. J. of Appl. Rad. and Isot. 20, 623 (1969).
- (9) ANDERSON, E.C., Brit. J. of Rad. (Suppl. 7), 27 (1957).
- (10) ANDRASI, A. and FEHER, I., Kernenergie 12, Heft 4 (1969), Budapest.
- (11) LUCAS, H.F., Jr., ANL-6297, p 55, July-Dec. (1960).
- (12) DE BORTALI, M. and GAGLIONE, P., Health Phys. 22, 43 (1972).
- (13) CARDINALE, A. et al., Health Phys. 20, 285 (1971).
- (14) NUTH, H. et al., Health Phys. 2, 239 (1960).
- (15) IVAN KOBAL, et al., Health Phys. 27, 381 (1974).

MESURE DE RADIUM DANS LES TISSUS BIOLOGIQUES  
DANS LE SITE RADIOACTIF DE RAMSAR (IRAN)

B.Khademi et C.Levain

School of Public Health, University of Tehran, Iran

Introduction

Nous avons débuté l'étude de la zone radioactive de Ramsar (nord de l'Iran) il y a environ 10 ans. En premier lieu, les eaux minérales ont été étudiées et nous avons trouvé deux catégories de sources:

- non-radioactives dont la concentration en radium de l'eau est inférieure à 5 pCi/l.
- radioactives dont la teneur en radium varie de 2000 à 10000 pCi/l. (plus de 50 sources)

Dès lors, nous avons commencé une étude plus complète de la région sur la teneur en radium du sol, des produits alimentaires qui poussent dans cette zone, des animaux et des os des hommes. Cette étude est menée en collaboration avec le "Service de Protection Sanitaire" du Commissariat à l'Énergie Atomique (Fontenay-aux-Roses, France) et avec le "Health and Safety Laboratory" (New-York, U.S....).

La zone actuellement considérée comme fortement radioactive a une surface d'environ  $1 \text{ km}^2$ , sur laquelle vivent plus de 2000 personnes. Dans l'avenir peut-être découvrirons-nous une zone beaucoup plus étendue.

Dans cette communication, nous présenterons les résultats de mesures de concentration de radium dans les tissus biologiques, mais avant tout nous donnons une description des champs d'expérience.

Description des champs d'expérience

Dans la zone considérée comme fortement radioactive, la radioactivité d'environnement et la radioactivité du sol sont très inhomogènes. Elles varient entre 200 et 15000 c/s pour la première et entre 17 et 900 pCi/g pour la seconde. Pour l'étude de transfert de radioactivité jusqu'à l'homme, nous avons choisis trois champs:

n°	tissus	lieu	pCi Ra-226 /g de cendre	lab.
1	os mouton	Téhéran témoin	0.07± 0.01	Téhéran
2	" "	Ramsar témoin	0.08± 0.02	"
3	os mouton	champ n°1	0.51± 0.16	"
4	" "	champ n°2	0.41± 0.15	"
5	chair mouton	Téhéran témoin	0.05± 0.01	"
6	" "	Ramsar témoin	0.05± 0.01	"
7	chair mouton	champ n°1	0.08± 0.01	"
8	" "	champ n°2	0.07± 0.01	"
9	poule <sup>x</sup>	Téhéran témoin	0.08± 0.02	"
10	"	Ramsar témoin	0.08± 0.02	"
11	poule	champ n°1	1.37± 0.12	CIA France
12	"	champ n°2	1.39± 0.12	Téhéran
13	dents hum.	Téhéran témoin	0.01	"
14	dent f.60a.	champ n°1	0.4 ± 0.1	CIA France
15	dents enfants	champ n°2	0.15± 0.02	Téhéran
16	" "	champ n°2	0.158± 0.014	ESL

x partie comestible de la poule

tableau n°1: Concentration de <sup>226</sup>Ra dans les tissus biologiques  
de Ramsar 1974-1976

lieu de prélèvement	sexe	age	pCi Ra-226 /g de cendre	pCi Ra-226 /g de calcium
Téhéran	M	52	0.02± 0.01	0.07± 0.01
Téhéran	F	55	0.02± 0.01	0.06± 0.03
Ramsar	M	50	0.04± 0.07	0.12± 0.20
Ramsar	F	20	0.04± 0.01	0.18± 0.03
Ramsar	S	55	0.02± 0.02	0.09± 0.08
Ramsar	F	60	0.02± 0.01	0.09± 0.01
Ramsar	M	60	0.04± 0.01	0.14± 0.05

tableau n°2: Concentration de <sup>226</sup>Ra dans les vertèbres humains  
analysés par Dr. I. Pisenne (H.SL) 1976

- champ n°1. de radioactivité moyenne (2000)c/s) mais avec des points très radioactifs jusqu'à 10000c/s. Dans ce champ se trouvent deux maisons, un poulailler, un jardin potager, quelques orangers plus un bain thermal très riche en radium-226. Quatre moutons ont été élevés dans ce jardin. A leur nourriture normale, on a ajouté chaque jour 100ml d'eau radioactive à 4000pCi/l soit 400pCi/j.
- champ n°2. plus radioactif (de 2000 à 15000c/s) avec de très grandes variations. Sur ce terrain, se situent une école primaire de 200 élèves, la maison des instituteurs, une autre maison, deux jardins potagers, deux poulaillers, des orangers et de la prairie.
- champ n°3. de radioactivité plus faible (500 c/s en moyenne) et assez homogène ne contient que des cultures: légumes et fruits.

Ce nombre restreint de champs d'expérience a cependant déjà permis d'obtenir de nombreux résultats sur les produits alimentaires cultivés et consommés. Nous ne discuterons ici que les résultats concernant les êtres vivants.

### Résultats et discussion

La méthode d'émanation du gaz radon a été utilisée à Téhéran pour la mesure du radium-226.

Le tableau n°1 montre la concentration de radium dans quelques tissus des êtres vivants de la région considérée. L'os de mouton du champ n°1 contient plus de radium que celui du champ n°2, sans doute à cause de la composition différente de sa nourriture (plus 400pCi/j). Pour les deux moutons, les os contiennent 6 ou 7 fois plus de radium que ceux des zones non-radioactives. En ce qui concerne la chair des moutons, celle du champ n°1 est seulement un peu plus riche en radium que celle du champ n°2 qui elle-même ne diffère pas du témoin. La partie comestible des poules élevées sur les champs n°1 et 2 contiennent 17 fois plus de radium que celle des poules témoins.

Des dents humaines ont aussi été étudiées. La femme de 30 ans a toujours vécu dans le champ n°1 et sa dent contient 40 fois plus de radium que les dents témoins. Les dents du champ n°2 appartiennent à 10 enfants (de 6 à 8 ans) de l'école. Tous ces enfants ne vi-

vent pas toute la journée dans la zone radioactive et cependant la concentration en radium trouvée est 15 fois supérieure à celle des témoins.

Le tableau n°2 rapporte les résultats fournis par Dr. I. Eisenne du "Health and Safety Laboratory" de New-York. Dr. Eisenne a analysé les vertèbres d'habitants de Ramsar et de Téhéran. L'analyse trouve une déficience en calcium pour les sept échantillons. Les habitants de Ramsar ne vivent pas exactement sur le site radioactif mais consomment les produits de la région. Pour tous ces habitants, le nombre de picocuries de  $^{226}\text{Ra}$  par gramme de calcium est supérieur à celui des témoins de Téhéran.

Les thyroïdes d'animaux ont été étudiées pour connaître l'absorption de la radioactivité, par Dr. Hiddleworth de l'Université de Tennessee. Seuls les résultats des animaux témoins nous sont parvenus à ce jour: il n'y a pas de radium dans les thyroïdes des moutons et vaches témoins.

L'étude de la région de Ramsar se poursuit afin de connaître les modes de transfert du radium de la terre aux plantes et à l'homme.

## THE EFFECTS OF URANIUM MINING ON ENVIRONMENTAL GAMMA RAY EXPOSURES

Lewis M. Cook  
Bradley W. Caskey  
Martin C. Wukasz, P.E.

Texas Department of Health Resources  
Austin, Texas (USA)

### 1. INTRODUCTION

Uranium mining has been conducted by several companies in south Texas since the mid 1950's after deposits were discovered on the surface. Most of the ore removed since the early 1960's has come from depths of 20 to 50 meters, and is mined by the open-pit method. This process leaves piles of waste rock and the deep pit at abandonment. This waste rock, termed overburden, can contain enough uranium and progeny to produce gamma ray exposure rates greater than the 0.5 rem per year limit required by the Texas Department of Health Resources (TDHR) for non-occupationally exposed persons.

After a south Texas land owner announced his plans to build a home on an overburden pile, it was decided to perform radiation surveys of abandoned mines in the area. This report contains results of 21 such surveys.

### 2. DESCRIPTION OF MINING AND SURVEY TECHNIQUES

The south Texas uranium deposits occur in isolated pockets as "roll front" deposits. The boundaries between barren sandstone and mineralized rock are sometimes sharp and oftentimes indistinct. The concentrations of uranium can range several thousand fold in distances from one meter to several tens of meters in both vertical and horizontal directions. The distinction between ore and rock to be wasted is, therefore, based upon economic rather than physical considerations.

Before a deposit can be mined, it is necessary for the area, grade and thickness of the ore to be determined by obtaining gamma ray logs of holes drilled in and around the area to be mined. Prior to any mining, the topsoil in the area of the pit and overburden piles may be removed and stockpiled. The overburden is then removed and piled near the pit. As the ore is approached, the uranium content of the removed rock is continually checked. When the grade exceeds the lower limit for milling, the ore is brought to the surface and piled upon the ore pad, an area prepared for that purpose. Next, the ore is loaded onto trucks and shipped to the mill. Historically, the mines were abandoned at this point.

The last material taken from the mine prior to ore removal contains uranium concentrations just below the mill cutoff limit. The elevated radiation levels on the top of the overburden pile can exceed 200 microRöntgen per hour ( $\mu\text{R/hr}$ ). Our regulatory limit of 0.5 rem per year corresponds to 57  $\mu\text{R/hr}$  above background. If the ore is incompletely removed from the ore pad, it, too, will have high radiation levels.

As practiced prior to the adoption of land reclamation rules by the Texas Railroad Commission, mining left the land with the overburden piled at or near its angle of repose and, as the rock was frequently lacking necessary nutrients for plant growth, the piles were barren. The radiation levels often exceeded 0.5 rem per year also, but the land was considered wasted and of no value as residential property. Water which collected in the pits was often unfit for consumption due both to high dissolved solids content and radioactivity (1). The adoption of practices complying with standards governing the levels of radiation and land reclamation by mining companies is restoring the agricultural and residential value of newly mined areas.

The survey procedure developed by the TDHR uses 25 x 25 mm sodium iodide detectors in a commercially available instrument. The meters have been calibrated in  $\mu\text{R/hr}$  by the US Environmental Protection Agency (EPA), which loaned us two of the instruments used in the survey, and by the authors for later calibration of the EPA and the TDHR instruments. The measurements were taken at 0.6 meter nominal heights, usually every 90 meters on parallel lines placed 100 meters apart. Due to the rough nature of the terrain, it was often necessary to alter either the direction or spacing of the lines, and occasionally the spacing between measurements. A survey of the Smith Mine is shown in Figure 1 as an example.

Surveyed mines include those most recently mined as well as some of the older mines. The mines omitted from this survey were omitted because of legal disputes, the fact that mining was in progress, or for time constraints.

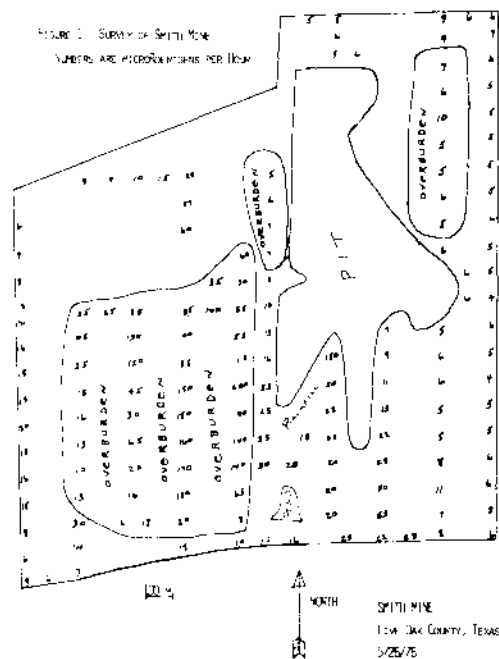

TABLE 1. INDIVIDUAL MINE DATA

MINE NAME	Number of Measurements	% $\geq 62 \mu R/hr$	Backfill Slope Red. Covering Normal Bg.	CAUSE
Korzekwa #1 & 2	85	38		BG, P, OS
Salen	125	21	*	OB, OP
Molan #1	59	44		OB, OP, P, BG
Koppin	80	9	*	OB, OP
Weddington	157	13	*	OB, P
Felder #1, 2, 3	458	27	*	OB, OP
Law	132	1.3	*	P
Ryan	37	21	*	OB, BG
Gillette Group	224	4.5	*	OB
McGrady	172	0.6	*	OB
Wright	77	0	*	OB
Fzell	70	0	*	OB
Stodtje	157	3	*	OB, OP
Manke	113	3.5	*	OB, OP
Pawelek	105	5	*	OP, OB
Smith	151	13	*	OB
Wilson #5	40	18	*	OB, OP
Becker	83	0	*	OB
Esse	115	3.5	*	OP, OB
Brown	109	0	*	OB
Kotzko	58	0	*	OB
All Mines	2393	10		
Old Mines	708	24		
New Mines	1684	4		
No Reclamation	901	21		
Partial Reclamation	490	2		

### 3. RESULTS AND CONCLUSIONS

High gamma ray exposure rates (in excess of 62  $\mu R/hr$ ) were found on 16 of 21 mined areas surveyed. The causes believed responsible for these high levels are: mineralized overburden (15 of 16); ore pads (8 of 16); mineralized rock in the pit (4 of 16) and background levels over 62  $\mu R/hr$  (3 of 16).

The mines surveyed are listed in Table 1 in approximate chronological order of the first date of mining. The oldest mine surveyed is the Korzekwa #1 mine dug in 1958 or 1959. The Felder mines were begun in 1969 and are the most recent of the mines considered 'old' for this study. The youngest mine is the Kotzko, mined in 1976 and surveyed as reclamation work was being completed. The group considered 'new' includes all mines dug to feed a mill opened in 1972, as well as new mines of other companies. The efficiency of the new mill was greater than that of the other two in the area. That, along with the increase in the prices of uranium, resulted in a lower mill cutoff limit and a correspondingly lower radiation level in the wasted rock. Most of the recent mining has also included some land reclamation, including reducing the steepness of the overburden piles, covering them with stockpiled topsoil, and wasting the ore pad into the pit. Topsoil depth on the overburden piles is related to topsoil depths prior to mining, usually zero to three meters. The surveyed areas are listed in Table 1, with the number of measurements, percent of measurements exceeding 62  $\mu R/hr$ , four columns to indicate if any backfilling of the pit, slope reduction of the overburden, covering of the overburden, and normal background existed. An asterisk (\*) means 'yes'. The column labeled 'Cause' contains the reasons for the high readings in order of frequency at that mine. In this column 'BG' means the background exceeded 62  $\mu R/hr$  in at least one spot, 'OB' means the overburden exceeded the limit, 'OP' means the ore pad exceeded it, and 'P' means there was mineralized rock accessible in the pit exceeding the 67  $\mu R/hr$  limit plus an assumed normal 5  $\mu R/hr$  background.



Totals for all mines, those classified as 'old', 'new', those with no reclamation, and those with partial reclamation are also listed. Partial reclamation means reducing the slopes of the overburden piles and covering them with whatever topsoil existed. Backfilling was not considered to be reclamation.

The data in Table 2 is a summary of the survey data. The frequency of readings falling within each of the indicated ranges (each one fifth of a decade on a logarithmic scale) for all mines, and for the four classifications of mines, is shown. The histograms in Figure 2 are for the cases of no reclamation and partial reclamation and are from the Table 2 data. An obvious difference exists in the distribution of radiation levels between the two classifications. Radiation levels are considerably higher for the case of no reclamation. Reclamation efforts without regard to the radiation levels (as the reclamation has been done in the past) are very successful in reducing the gamma ray exposure rates on abandoned uranium mines, but are not completely successful in reducing them to below the regulatory maximum. Mines abandoned without reclamation efforts present potential radiation hazards to persons who may occupy homes built there. The hazard stems from the direct gamma ray exposures and from the radon emanating from the mineralized rock. It should be emphasized that our limit on radiation levels of 57  $\mu\text{R}/\text{hr}$  above background resulting from uranium ore may not provide sufficient protection from radon to occupants of buildings which may be built upon that land (2).

Similar results are obtained by comparing the 'old' to 'new' mines, but nearly the same two groups of mines are being compared, as can be seen from close inspection of Table 1.

Current requirements for reclamation by both Texas agencies regulating uranium mining include sloping the overburden piles to reduce erosion; covering the piles to provide shielding and reduce slightly the radon emanation; planting grasses to reduce erosion; removing all traces of ore from the ore pad; and contouring the land to drain rainfall runoff into the pit reducing the dissolved mineral content (and thereby the radioactivity) and allowing silt to cover the pit bottom.

TABLE 2. STATISTICAL SUMMARY OF SURVEY MEASUREMENTS

CRITERION	DOSE RATE ( $\mu\text{R}/\text{HR}$ )														
	0-5	6-9	10-15	16-25	26-39	40-62	63-99	100-138	159-251	252-398	399-631	632-999	1000-1500	1591-2520	2521-UP
All Mines	4.6	29.8	27.8	15.5	7.5	5.1	3.2	3.3	2.3	0.6	0.1	0.0	0.04	0.04	0.04
Old Mines	0.4	6.9	16.8	21.6	15.6	10.5	7.5	7.2	6.4	1.8	0.4	0.0	0.1	0.0	0.1
New Mines	6.4	38.6	31.6	12.9	4.0	2.7	1.4	1.7	0.5	0.1	0.0	0.0	0.0	0.1	0.0
No Reclamation	2.9	11.4	16.2	21.7	14.4	9.8	6.9	7.1	5.6	1.4	0.3	0.0	0.1	0.0	0.1
Partial Reclamation	5.6	40.9	34.6	11.7	3.3	2.3	1.0	1.3	0.2	0.1	0.0	0.0	0.0	0.1	0.0

Other reclamation possible includes totally backfilling the pits, usually an expensive alternate unless the material comes from an adjacent pit. Weakly mineralized rock could be stockpiled separately and covered. This would allow future milling without more mining, should it become economical.

#### 4. SUMMARY

Uranium mining has resulted in radiation levels at some abandoned uranium mines exceeding regulatory limits. On approximately one-tenth of the mined area of south Texas, radiation levels exceed 0.5 rem per year. In three instances, levels exceed 5 rem per year. Although no one is believed to be receiving exposures in excess of 0.5 rem per year now, the area being mined is increasing, and so is the State's population. Individuals occupying a dwelling built on an area exceeding our limits could receive excessive lung exposures from radon as well as gamma ray exposures exceeding 0.5 rem per year.

Radiation levels on mines can be reduced through reclamation efforts on the part of the mining company. One of the most effective methods is to cover the overburden piles with dirt or rock not containing significant concentrations of uranium and its progeny and by wasting the ore pad into the pit.

FIGURE 2. FREQUENCY OF OCCURRENCE OF GAMMA RAY EXPOSURE RATES FOR THE CASES OF PARTIAL RECLAMATION AND NO RECLAMATION OF MINED AREAS.

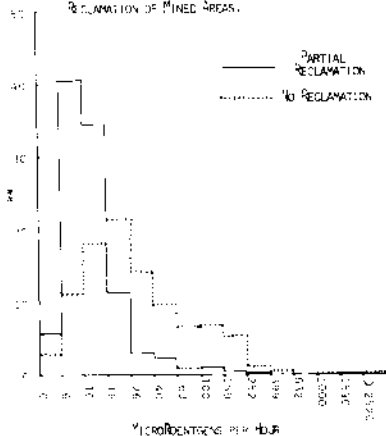

While covering the mineralized overburden with topsoil effectively reduces the gamma ray dose rate, it is insufficient protection against radon 222 emanation unless the cover is several meters thick. This is not always possible using locally available topsoil for cover.

#### 5. ACKNOWLEDGEMENTS

The writers would like to thank the personnel of the Compiasta Project for their cooperation during the surveys and Mr. Abel Chapa of the El Paso County Health Department for assisting in some of the surveys.

#### 6. REFERENCES

- Wekasch, M.D. and Cook, T.M., 1972. 'Environmental Surveillance in South Texas' in The National Radiation Environment II, p. 845 (U. S. ERDA CONF - 720805 p. 2).
- Fitzgerald, J.D.; Guimond, R.J.; and Shaw, R.A.; November 1976. 'A Preliminary Evaluation of the Control of Indoor Radon Daughter Levels in New Structures' U. S. EPA.

## HIGH NATURAL RADIOACTIVITY OF BORED WELLS AS A RADIATION HYGIENE PROBLEM IN FINLAND

O. Castrén, V. Asikainen, M. Aramäki and Kristina Stenstrand  
Institute of Radiation Protection, P.O. Box 268, Helsinki 10, Finland

### 1. INTRODUCTION

The highest concentrations of natural radioactivity in ground water in Finland have been found in wells bored in rock (1,2). Bored wells are often used as alternatives to ordinary wells in places where the quantity or quality of the water is insufficient. These wells are typically situated on outlying farms or on the outskirts of population centres where no municipal distribution net exists. The highest concentrations found so far in bored wells are 1.2  $\mu\text{Ci/l}$  (45  $\text{Bq/l}$ ) of radon-222, 256  $\text{pCi/l}$  (9.5  $\text{Bq/l}$ ) of radium-226 and 14.9  $\text{mg/l}$  of uranium.

On the sole basis of the old maximum permissible concentrations of ICRP (3), the most serious problem would seem to be the high radium levels. However, the obsolescence of the old MPC for radium has been widely admitted, and recently a proposal was made that would mean revising the value upwards by a factor of about 50 (4). A more serious problem has proved to be the high radon concentrations in the air of dwellings where radon-rich household water is used, as suggested by Gosell and Prichard (5). The purpose of the present work is to find a rough preliminary estimate for the extent of the problem in Finland. The estimate is based on the measurements of radon in water. Results of the analyses of water samples collected in 1975-76 and results of chromosome analyses of some of the residents are also presented.

### 2. TRANSFER OF RADON FROM WATER TO AIR

An important parameter necessary in the interpretation of the water results is the ratio of the average radon concentration in a person's breathing air to that in the household water. In the following, this quantity is called the transfer coefficient from water to breathing air. Only radon originating from water is included in the numerator and it is implied that the averages are taken over a time that is long enough to include all normal variations.

Measurements of radon in air were performed in 7 dwellings each of which had a radon concentration in water of over 50  $\text{nCi/l}$  (1.9  $\text{Bq/l}$ ). The scintillation chamber method was used. Because the transfer coefficient is highly dependent on the person's contact with water, the measurements were aimed at determining two concentrations. The first, representing situations where contact with water is extensive, was determined by simply measuring the concentration in the bathroom or sauna after letting about 100 litres of water run to the drain. The second, representing the rest of the time spent indoors, was determined in cooperation with the residents. A series of 5 to 7 evacuated chambers were left with them and instructions given to take samples from the places where they would normally be during the day. As a rule, measurements were made on three days, one of which was a day of high water consumption. Most samples were taken from the bedroom, sitting-room or kitchen. The resulting concentration ratios together with the arithmetic means are shown in Table 1.

Dwelling no.	Radon in tap water		Concentration ratio during	
	nCi/l	kBq/l	contact with water	other time spent indoors
1	520	19.2	$11.5 \cdot 10^{-4}$	$0.05 \cdot 10^{-4}$
2	150	5.6	23.3 "	0.38 "
3	140	5.2	19.3 "	0.27 "
4	180	6.7	41.0 "	0.80 "
5	140	5.2	19.8 "	0.97 "
6	59	2.2	23.3 "	0.66 "
7	1200	44.4	6.75 "	0.93 "
Mean:			$20.7 \cdot 10^{-4}$	$0.68 \cdot 10^{-4}$

TABLE 1 Ratio of concentrations of radon in breathing air and household water

The results for individual dwellings may be biased by the reactions of the residents. Thus the low value in the last column of dwelling no.1 is clearly the result of the residents' efforts to keep the concentration low by efficient ventilation. In one case (no.4) the well was given up after the first measurement. All houses except nos.2 and 5 were of wood.

The transfer coefficient from water to breathing air can be calculated as the mean of the two concentration ratios given in Table 1 by weighting them with the time spent daily in each situation. For the purposes of the survey, transfer coefficients were calculated for two groups of people using the means given in Table 1. The first group, consisting of persons performing household duties as a full-time job, housewives and small children, was assumed to spend 21 hours a day indoors and one hour of it in contact with water. The second group, consisting of all other residents, was assumed to spend 14 hours indoors and 20 min of it in places where water is used extensively. The transfer coefficient for the first group, which was assumed to amount to one third of the population, is accordingly  $(20 \cdot 0.6 + 1 \cdot 21) \cdot 10^{-4} / 24 = 1.4 \cdot 10^{-4}$ . For the second group, the effect of contact with water is minor and the transfer coefficient is about  $0.6 \cdot 10^{-4}$ .

### 3. RESULTS OF CHROMOSOME ANALYSES

About 3700 leukocytes from 10 people were analysed cytogenetically. The results are shown in Table 2. Groups nos.1, 2 and 3 represent residents of dwellings 1, 2 and 7 of Table 1, respectively.

Group no.	Radon in air pCi/l	Bq/l	Time a	Number of people	Unbalanced exchanges (dic+R <sub>1</sub> )	Balanced exchanges (t + inv)	Single breaks (ace + m <sup>1</sup> )
1	40	1.5	15	3	4/1506	5/1506	18/1506
2	15	0.6	10	5	0/1258	0/1258	2/1258
3	100	3.7	8	2	3/1000	1/1000	7/1000

TABLE 2 Chromosome aberrations in some radon-exposed groups

For obvious reasons, the exposure data are very approximate. However, in groups 1 and 3 with more exposure the frequency of radiation specific

aberrations (dicentric and rings) is seen to be higher than that found normally in reference populations (1/3000 - 1/4000).

#### 4. SURVEY DATA ON RADON AND RADIUM IN THE WATER OF BORED WELLS

The radon results from the 193 bored wells analysed in 1975-76 are presented in Table 3. Higher concentrations can be found in the region of Helsinki than in other parts of the country. For comparison, the mean radon concentration in a total of 600 ordinary ground water samples analysed so far is 1.7 nCi/l (63 Bq/l), the most likely value being about 1 nCi/l (40 Bq/l). The radium results from the 238 bored wells analysed in 1975-76 are presented in Table 4.

Location	Number of wells				
	<1 nCi/l	1-10 nCi/l	10-100 nCi/l	100-1000 nCi/l	>1000 nCi/l
Helsinki and Vantaa	4	12	65	29	0
Other parts of Finland	11	56	30	7	1

TABLE 3 Radon in the water of bored wells in Finland. Results from 193 samples. Not all wells are in regular use.

Location	Number of wells				
	<1 pCi/l	1-3 pCi/l	3-10 pCi/l	10-100 pCi/l	>100 pCi/l
Helsinki and Vantaa	28	22	32	32	0
Other parts of Finland	75	20	17	12	2

TABLE 4 Radium-226 in the water from bored wells in Finland. Results from 238 samples. Not all wells are in regular use.

The distribution of the radon concentration in tap water versus the number of users is presented in Table 5. Most of the bored wells supplying water to more than 200 users each have been analysed. For the second and third rows, sufficient statistical data are not available and the results represent only samples analysed to date. As an order of magnitude it can be estimated that the total number of users in these groups is between 100 000 and 200 000.

Type of usage	Number of users				
	<1 nCi/l	1-10 nCi/l	10-100 nCi/l	100-1000 nCi/l	>1000 nCi/l
Waterworks, more than 200 users	5100	8000	6100	0	0
Small waterworks, schools, factories etc.	120	330	210	10	16
Private households	30	160	470	170	0

TABLE 5 Radon in the tap water from bored wells

## 5. NATIONAL ESTIMATES FOR THE EXTENT OF THE RADON PROBLEM

For comparison it is useful to express the annual radon daughter exposure in terms of working level months (WLM) used in the monitoring of mines. If radon is in equilibrium with daughters, a continuous average concentration of 1 pCi/l corresponds to 0.5 WLM/a. Assuming the average equilibrium factor to be 0.5, the best estimate would perhaps be 0.25 WLM/a.

The normal ambition levels for the limitation of radon concentration in air are 1-2 pCi/l in the air of dwellings and 4 WLM/a in mining work. For the radon concentration in air to be lower than 1.5 pCi/l, the concentration in water should be less than 10 pCi/l. According to Table 3, there is reason to believe that about 40 percent of the bored wells in Finland would not satisfy this criterion. On the other hand, 4 WLM/a corresponds to 16 pCi/l. For the higher exposed group of users this would mean that the concentration in water should be less than about 110 pCi/l. Approximately 8 percent of the bored wells in Finland would not conform to this ambition level. If the protection level of users is compared with that of the miners, it should be borne in mind that some of the users may live under the influence of the well for longer than the miner's working years and are possibly exposed as early as their childhood.

Auxier (6) has used 100 WLM as lung cancer doubling dose in discussing the ambition level for the radon exposure in buildings. According to the data of the present study, it can be estimated that more than 10 000 users of water from bored wells may receive 100 WLM in 40 years, if the present situation remains unchanged. In practice, this is seldom the case, even if nothing is done to prevent the exposure. Most bored wells are relatively young (less than 20 years), and for this reason only very few people may already have received 100 WLM. In some of the cases found to date, remedial action to reduce future exposure has already been successful.

## 6. REMEDIAL ACTION

During the measurements in dwellings it was found that people who know about the radon content of the water could lower the concentration in the air by an order of magnitude by changing their habits of water use. It is also technically easy to remove radon from water using an aerator. In the typical case of small private wells it may, however, be difficult to find an economically feasible solution. In population centres the most efficient solution is probably the extension of the municipal distribution net to the areas of private well users.

## REFERENCES

- (1) KAHLIN, H., "Radon-222 concentration of some water samples determined with gamma-spectrometric measurements", Report SFU-A14, Helsinki 1961.
- (2) KAHLIN, H. and ASTIKAINEN, M., "Natural radioactivity of ground water in the Helsinki area", Report SFU-A19, Helsinki 1973.
- (3) Recommendations of the International Commission on Radiological Protection, ICRP Publication 2 (1959).
- (4) THORNE, Y.C. and WENNER, J., The toxicity of  $^{90}\text{Sr}$ ,  $^{226}\text{Ra}$  and  $^{222}\text{Rn}$ , *Nature* 203, 555 (1976).
- (5) GUSELL, THOMAS P. and PRICHARD, HOWARD V., The technologically enhanced natural radiation environment, *Health Phys.* 28, 491 (1975).
- (6) AUXIER, J.A., Respiratory exposure in buildings due to radon progeny, *Health Phys.* 21, 119 (1976).

## RADIUM IN VEGETABLE GARDENS

J.G. Hollins

National Research Council of Canada  
Ottawa K1A 0R6

The contamination of soil in a town in which the refining of radium and uranium has been carried out for 40 years has raised the question of the maximum concentration of radium that may be permitted in the soil of a domestic vegetable garden.

The soil may be contaminated with all the members of the uranium series, but radium is likely to make the major contribution to the dose commitment of people who eat vegetables grown in this soil. Work on the uptake of the four long-lived radionuclides of the uranium series by red kidney beans showed that the concentration of radium in the roots was two to three times lower than that of the other nuclides, but the upward transport of radium was between 50 and 200 times greater<sup>1</sup>. This evidence is consistent with the observation of Mayneord<sup>2</sup> that the contribution of radium to the alpha activity of plants is much greater than that of thorium.

An evaluation of the maximum permissible concentration of radium in soil requires knowledge of the transfer of radium from soil to plants, the gastrointestinal absorption of radium from food, the rate of consumption of food, the maximum permissible amount of radium in the body, and the retention of radium by the body.

A Belgian study<sup>3</sup> of the uptake of radium by plants grown in contaminated fields provides data most pertinent to our concerns. Effluents from a factory that extracted radium from uranium ores for 40 years discharged into a stream that from time to time overflowed its banks. Land that was being developed for agriculture was flooded with contaminated water when dikes were breached during heavy rains. The concentration of radium by plants grown on this land, expressed as the ratio of the concentration of radium in dry plant to that in dry soil, is used here as the best estimate of the transfer of radium from soil to plant.

The gastrointestinal absorption of radium from food was found to be 20% in a four-year old boy<sup>4</sup>. An absorption of 20% has also been reported in elderly people<sup>5</sup>. Other observations on adult males have been extremely variable, ranging from zero to 60%<sup>4</sup>.

Estimates of the annual consumption of food by Canadians have been taken from the reports of Statistics Canada<sup>6</sup>.

The maximum permissible body burden of 0.1  $\mu\text{Ci } ^{226}\text{Ra}$  for occupationally exposed people was established by an advisory committee of the United States' National Bureau of Standards in 1941<sup>7</sup>. It was based on a study that began in 1932. Subsequent investigations of cases involving dial painters, radium chemists, and patients treated with radium have not affected this standard<sup>8</sup>. In 650 cases studied up to 1970, no radiation injury was detected in people with a residual body burden of less than 0.5  $\mu\text{Ci } ^{226}\text{Ra}$ . Following the International Commission on Radiological Protection, we may take 0.01  $\mu\text{Ci } ^{226}\text{Ra}$  as the maximum permissible body burden for people who are not occupationally

exposed.

An exponential equation for the retention of radium by man, a refinement of the equation given in ICRP Publication 10A, has been used to calculate the daily uptake of radium for various periods of time that would lead to a body burden of 10 nCi  $^{226}\text{Ra}$ . The exponential equation was used for simplicity of computation of the values used in the present work. It graduates the data as well as the function given in ICRP Publication 20, giving the same values of retention and time integrals. Daily uptakes of radium were calculated that would lead to a body burden of 10 nCi at the end of a period of contamination, or averaged over the duration of the period of contamination.

The daily rate of uptake,  $U$ , during a period of  $s$  days, followed by a period of uptake at the normal dietary rate,  $N$ , that would lead to an average body burden of 10 nCi during 50 years was also calculated and it is presented in Figure 1.

FIGURE 1

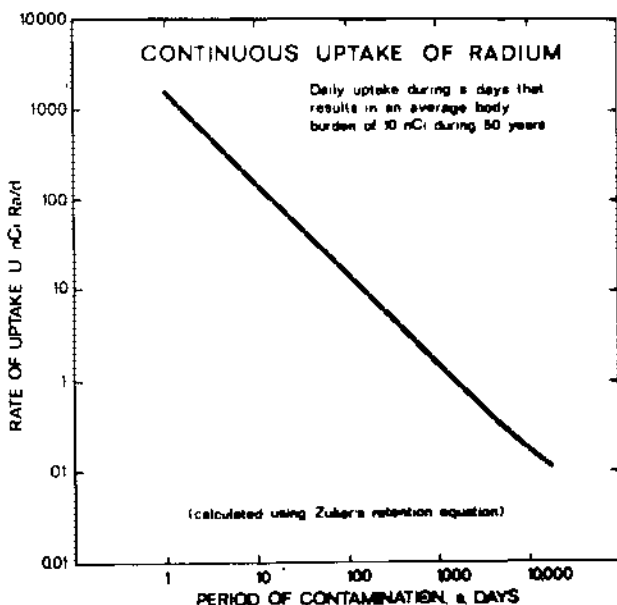

The variation with time of the body burden of radium during and after various initial periods of contamination is illustrated in Figure 2. Each of these patterns of contamination results in the same integrated activity of 200  $\mu\text{Ci}$ -days, although the body burdens at the end of 20,000 days vary by a factor of 5.



FIGURE 2

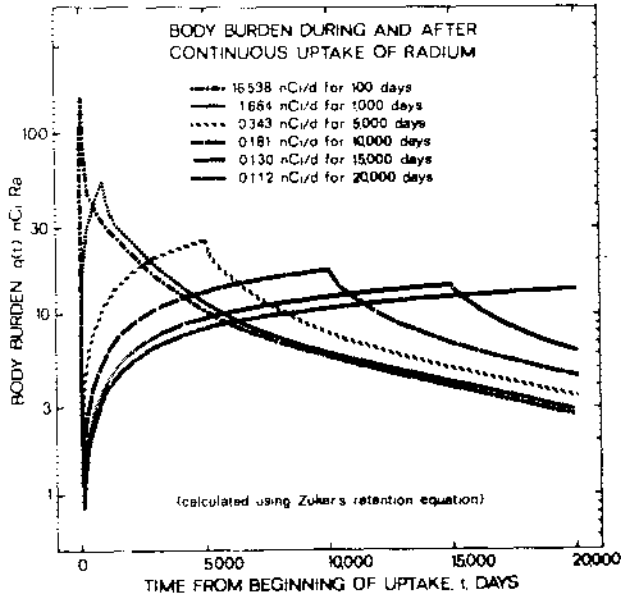

The following assumptions were made in order to calculate the concentration of radium in soil that will lead to an average body burden of 10 nCi during 50 years due to consumption of vegetables grown in the soil:

- the ratio of concentrations of radium in dry vegetable and dry soil is 0.025 for potato tuber and 0.25 for other vegetables.
- the ratio of fresh weight to dry weight for potatoes is 4.5 and for other vegetables is 11<sup>9</sup>.
- the average Canadian consumes 69 kg of potatoes a year and 86 kg of other vegetables, including tomatoes, a year.
- gardeners grow enough potatoes to satisfy their annual consumption and enough other vegetables to satisfy their consumption for 15 weeks a year.
- the gastrointestinal absorption of radium is 20%.

The annual uptake of radium, A nCi, is given by

$$A = G(W_p \times F_p \times C_p \times S + W_v \times F_v \times C_v \times S)$$

where S is the concentration of radium in soil in nCi/kg,  
 $W_p$  and  $W_v$  are the annual consumption per capita of domestically-grown potatoes and other vegetables,  
 $C_p$  and  $C_v$  are the concentration factors,  
 $F_p$  and  $F_v$  are the ratios of dry to fresh weight, and  
 $G^D$  is the gastrointestinal absorption of radium.

The concentration of radium in soil is thus

$$S = \frac{A}{G(W_p \times F_p \times C_p + W_v \times F_v \times C_v)}$$

and substituting the values given in the assumptions above,

$$S = 5.3 \times A \text{ nCi/kg dry soil.}$$

Consider, as examples, three cases of contamination for total periods of 50 years:

- contaminated food for 25 years,  $S = 360 \text{ nCi/kg}$
- contaminated food for 5 years,  $S = 1.7 \text{ } \mu\text{Ci/kg}$
- contaminated food for 1 year,  $S = 8.2 \text{ } \mu\text{Ci/kg}$ .

These examples illustrate the way in which the permissible concentration of radium in soil may vary depending on the duration for which a vegetable garden is to be used. The most stringent condition would be the use of a garden for 50 years, which requires contamination of the soil of less than 220 nCi/kg.

There are many approximations in these calculations, but the results provide a clear idea of the scale of the problem of contamination of vegetable gardens by radium. The calculated concentrations of radium in soil depend on the accuracy of estimation of 5 quantities: A, which in turn depends on the retention equation, C, F, G, and W. The variability of the data on the retention of radium about the fitted equation given in ICRP 20 is between 10 and 20%. In a controlled experiment with healthy men<sup>10</sup>, the coefficient of variation of radiation dose due to internal contamination with radiocobalt was 20%. This measure of biological variability will be used as the accuracy of the calculated uptake of radium that results in a given dose commitment. The accuracies of the other variables are also estimated to be about +20%, which leads to an accuracy of +45% for the concentration of radium in soil. This estimated accuracy may perhaps be put in context by remembering the somewhat arbitrary factor of 10 that is applied to the permissible occupational burden to obtain a permissible burden for people who are not occupationally exposed.

#### References

1. D'Souza, T.J. and Mistry, K.B. *Radiation Botany* 10 293-295 (1970).
2. Mayneord, W.V., Turner, R.C., and Radley, J.M. *Nature* 187 208-211 (1960).
3. Kirchmann, R., Lafontaine, A, Cantillon, G, and Boulenger, R. Rapport du CEN de Mol, Belgique BLG 477 (1973).
4. Mayneord, W.V. The hazards to man of nuclear and allied radiations, a second report to the Medical Research Council, London 73-79 (1960).
5. Maletskos, C.J., Keane, A.T., Telles, N.C., Evans, R.D. Delayed Effects of bone-seeking radionuclides, Utah 29-49 (1969).
6. Statistics Canada, Catalogue 32226 (1975).
7. Curtiss, L.D. et al, U.S.N.B.S. Handbook 27 (1941).
8. Evans, R.D. *Health Physics* 27 497-510 (1974).
9. Spector, W.S., editor. *Handbook of Biological Data* 187 (1956).
10. Letourneau, E.G., Jack, G.C., McCullough, R.S., and Hollins, J.G. *Health Physics* 22 451-459 (1972).

POPULATION DOSE DUE TO TERRESTRIAL RADIATION  
AND DUE TO NATURAL RADIONUCLIDES IN PHOSPHATE FERTILIZERS  
IN THE URBAN REGION OF ERLANGEN/FRG

H.Pfister, G.Philipp, and H.Pauly

Institut für Radiologie der Universität Erlangen-Nürnberg  
Krankenhausstraße 12, D-8520 Erlangen

## 1. INTRODUCTION

Phosphate fertilizers are known to contain the natural radionuclides of the uranium series with specific activities which exceed the respective values in common soils by a factor of up to 50. In addition, radionuclides of the thorium series and, in mixed fertilizers,  $^{40}\text{K}$  may be present (1). Because of their extensive use in nearly all agricultural and greenland areas phosphate fertilizers may contribute to the external exposure of the population. Although estimates have shown that this additional external exposure should be negligibly small on the average (1), a more detailed quantitative analysis seems to be desirable which takes into account regional variations of both the additional and the natural exposure with sufficient accuracy and, thus, makes it possible to compare them to exposures due to other small environmental sources. As an example of such an analysis this investigation is restricted to the urban region of Erlangen/FRG with a total area of 76.78 km<sup>2</sup>, about 42% of which is agricultural or horticultural land, and a total population of 100500.

## 2. METHODS

### 2.1 Exposure due to phosphate fertilizers

The specific activities of  $^{226}\text{Ra}$ ,  $^{232}\text{Th}$  and  $^{40}\text{K}$  in the phosphate fertilizer species used in agricultural and horticultural areas in Erlangen have been determined by gamma ray spectrometry. From the relative amounts of the various fertilizer species and from the total mean annual phosphate nutrient supply in both types of areas and by assuming homogeneous distribution of the fertilizers in the soil down to 20 cm depth the mean exposure rates due to the gamma radiation of the natural radionuclides in phosphate fertilizers in 1 m above agricultural and horticultural land could be calculated. The calculation method which takes into account attenuation of the gamma radiation in soil and air and the build-up effect in the soil is described elsewhere (2). With realistic estimates of the mean and maximum annual residence times of the members of the population in the respective areas the mean and the maximum annual doses of the population due to phosphate fertilizers are obtained.

In addition, mean and maximum annual doses to individuals due to occupational exposure from radionuclides in phosphate fertilizers were determined from direct exposure rate and personal dose measurements in the respective working fields, e.g. in a fertilizer storeroom.

### 2.2 Exposure due to terrestrial radiation

Because of lack of detailed data the terrestrial population exposure has been determined starting from extensive exposure rate measurements over the

whole urban region of Erlangen by use of plastic scintillation dose rate meters (3) and, in a preliminary additional measurement series, of LiF dose meters. Exposure rate measurements were also done in a great number of dwellings and occupational buildings of all types.

To derive the range and the mean value of the terrestrial exposure of members of the population from the local exposure rate profile the results of the outdoor measurements were first grouped into the relevant locations "free land" (including forests, greenland, parks, gardens etc.) and "urban environment" (including habitats, streets, places and, especially, the inner city). All "free land" results were averaged to one mean exposure rate value, whereas, for the "urban environment", mean values were obtained from locally averaged results weighted by the residence or the occupational population densities. The mean exposure rates in dwellings and occupational buildings have been calculated by taking into account the relative portions of the various building types.

By taking into account mean annual residence times of working and unemployed persons at the various locations, indoors and outdoors, the mean value and the maximum range of the annual dose of members of the population due to the terrestrial radiation in Erlangen could be estimated. Allowance has been made for a cosmic radiation contribution of  $1 \mu\text{R/h}$  to the readings of the dose rate meters. All doses are obtained in mrem/y by applying a gonad and bone marrow/air dose-conversion factor of 0.6 (4) and a quality factor of 1.

The overall accuracy of the exposure rate measurements was about  $\pm 10\%$ . Some uncertainty of the absolute values may be given by the approximation for the cosmic ray contribution, but should not exceed widely the accuracy range estimated.

### 3. RESULTS

Table 1 shows the additional exposure rates and annual doses to gonads and bone marrow of members of the population and single individuals due to phosphate fertilizers in the urban region of Erlangen.

Table 1

	Exposure rate in $\mu\text{R/h}$	Annual dose in mrem	
		mean	max.
Population:			
agricultural areas	0.004	$2.5 \cdot 10^{-3}$	$1.5 \cdot 10^{-2}$
horticultural areas	0.021		
Individuals:			
occupational	10	11	45

In Table 2 the local exposure rate ranges and the mean exposure rates of members of the population together with maximum range due to the terrestrial radiation in Erlangen are summarized.

The mean annual dose of members of the population due to the terrestrial radiation in the urban region of Erlangen was calculated to be 33 mrem with a maximum range of 15 to 49 mrem.

Table 2

Locations	Exposure rate in $\mu\text{R}/\text{h}$		
	local	averaged	
		mean	range
"Free land"	2.9 - 5.7	4.7	2.9 - 5.7
"Urban environment"	2.7 - 11.0	-	3.4 - 7.7
residence density weighted	-	4.7	-
occupational density weighted	-	5.2	-
inner city	4.0 - 11.0	5.9	4.0 - 11.0
Dwellings	2.2 - 8.3	5.3	2.2 - 8.3
Occupational buildings	3.0 - 11.0	6.5	3.0 - 11.0

#### 4. CONCLUSIONS

The results show that the contribution of the gamma radiation of the radionuclides in phosphate fertilizers to the mean population exposure in the urban region of Erlangen is only 0.05 to 1.0% of the exposure due to the terrestrial radiation. This confirms more quantitatively our previous estimates (1). For some individuals, working in a fertilizer storehouse, however, the exposure due to phosphate fertilizers reaches 33 to 136 % of the terrestrial exposure.

The results of this study may serve as a quantitative basis for the evaluation of regional radiation risks due to other small environmental radiation sources and, especially, for their relative contributions to the additional radiation risk of the population.

This study has been supplied by the "Bundesministerium des Innern" of the Federal Republic of Germany.

#### REFERENCES:

- (1) PFISTER, H., G. PHILIPP, and H. PAULY: Rad. and Environm. Biophys. 12, 247-261 (1976)
- (2) PFISTER, H., G. PHILIPP, and H. PAULY: in preparation
- (3) Dose rate meters "Typ MAB 601" and "Typ MAB 603", Münchner Apparatebau Kimmel KG., 8012 Ottobrunn/FRG
- (4) United Nations: Report of the UNSCFAR: Ionizing radiation: Levels and Effects, Vol. I, p.38. New York 1972

EVALUATION DE LA DOSE A L'HOMME RESULTANT DE LA PRESENCE DE RADIONUCLIDES NATURELS DANS LES ENGRAIS PHOSPHATES D'ORIGINE MINERALE.

R. Kirchmann<sup>1</sup>, R. Boulenger<sup>2</sup>, J. Colard<sup>3</sup> et A. Lafontaine<sup>3</sup>

<sup>1</sup>Centre d'Etude de l'Energie Nucléaire, Mol, Belgique

<sup>2</sup>Contrôle-Radioprotection, ASBL, Bruxelles, Belgique

<sup>3</sup>Institut d'Hygiène et d'Epidémiologie, Bruxelles, Belgique

## 1. INTRODUCTION

Le phosphore est un élément majeur indispensable à la croissance des végétaux aussi l'Agriculture fait-elle appel aux engrais phosphatés sous diverses formes, depuis le début du siècle.

L'application d'engrais phosphatés d'origine minérale est la plus répandue en Belgique, environ 140.000 tonnes de  $P_2O_5$  en 1975, à titre de comparaison, les scories basiques ont été utilisées à concurrence d'environ 75.000 tonnes  $P_2O_5$ /an.

Il est bien connu que les phosphates minéraux contiennent de l'uranium et ses descendants dont le  $^{226}Ra$ . En raison de cet emploi généralisé des engrais phosphatés d'origine minérale, il nous a paru intéressant de rechercher l'incidence de cet apport sur la contamination des produits agricoles et d'évaluer la contribution de ces radionuclides à la dose d'irradiation interne de l'homme.

## 2. METHODE EXPERIMENTALE

Une quarantaine d'échantillons de phosphates naturels et d'engrais phosphatés de diverses origines, fournis par les services du Ministère de l'Agriculture, ainsi qu'une douzaine d'échantillons de scories basiques provenant des principaux producteurs belges et luxembourgeois ont été analysés afin d'en connaître les teneurs en  $^{226}Ra$  et en U naturel.

### 2.1. Techniques de mesures

La mesure du  $^{226}Ra$  de ces échantillons a été réalisée par spectrométrie gamma. Afin d'éviter un déséquilibre au niveau du radon-222 qui est gazeux, l'échantillon à mesurer est placé dans un flacon étanche adapté au cristal NaI(Tl) utilisé, en outre on complète le remplissage par du charbon actif.

La mesure de l'uranium est effectuée selon les méthodes d'analyse par activation: des échantillons de 2 g environ sont irradiés pendant 15 min. dans un flux de  $1.10^{14}$  n.cm<sup>-2</sup>.s<sup>-1</sup>. La fission de  $^{235}U$  fournit de nombreux radionucléides à partir desquels peut s'effectuer le dosage. On a choisi le  $^{140}Ba$ - $^{140}La$ , relativement facile à mesurer par spectrométrie  $\gamma$  grâce au pic de haute énergie du  $^{140}La$  (1,6 MeV - 95%). La présence dans les échantillons de  $^{139}La$  qui forme du  $^{140}La$  au cours de l'activation ainsi que les fortes activités de  $^{47}Ca$  et  $^{45}Sc$  obligent à effectuer une séparation chimique en vue d'isoler le  $^{140}Ba$ . Un délai de deux à trois jours entre la séparation chimique et la mesure permet d'obtenir en équilibre partiel du  $^{140}La$  sur lequel on effectue la mesure au moyen d'un cristal NaI (Tl) 3" x 3".

ces mesures ont été effectuées en 1966.

## 2.2. Résultats

Les valeurs limites et moyennes résultant de l'analyse des divers types d'engrais phosphatés sont indiqués dans le tableau 1. A noter que les phosphates naturels analysés ont des teneurs assez constantes à l'exception cependant des phosphates provenant de Kola dont les teneurs sont beaucoup plus faibles. Les produits préparés ont des teneurs variables en radionucléides naturels mais la plupart des "super" accusent des teneurs en  $^{226}\text{Ra}$  atteignant encore 75% de celles des phosphates bruts; Les teneurs en U naturel des "super" variant entre 40 et 80% de celles des phosphates bruts.

Engrais	P <sub>2</sub> O <sub>5</sub> (%)	$^{226}\text{Ra}$			$^{238}\text{U}$		
		pCi.g <sup>-1</sup>			ppm		
		min.	max.	moyenne	min.	max.	moyenne
Phosphate naturel	33	<2,2	44	36,5	4,8	190	108,4
Super simple	18	22	27	25,2	44,9	86,4	62,7
Super double	40	18	19	18,7	60,7	149	110
Bicalcique	40	<3,7	2,3	2,7	24,3	45,8	36,0
Scories	15	0,2	0,6	0,52	0,6	4,1	1,9

TABLEAU 1 Teneurs en  $^{226}\text{Ra}$  et en  $^{238}\text{U}$  observées dans des échantillons d'engrais phosphatés.

Quant aux scories basiques, les résultats d'analyse ont montré qu'elles contiennent, en moyenne, 70 fois moins de  $^{226}\text{Ra}$  que les phosphates minéraux d'origine naturelle.

## 3. TRANSFERT DE $^{226}\text{Ra}$ DANS LA CHAÎNE ALIMENTAIRE, ACTIVITÉS INGERÉES ET DOSE RESULTANTE.

L'apport annuel, aux terres cultivées, de  $^{226}\text{Ra}$  et  $^{238}\text{U}$  provenant de l'application d'engrais phosphatés d'origine minérale, est estimé dans le tableau 2.

Engrais	Quantités appliquées (kg.ha <sup>-1</sup> )	$^{226}\text{Ra}$ (pCi.ha <sup>-1</sup> )	$^{238}\text{U}$ (g.ha <sup>-1</sup> )
Super simple (18%)	412,5	10,4	25,9
Super double (40%)	187,5	3,5	20,6
Bicalcique (40%)	187,5	0,5	6,7
Phosphate naturel (33%)	225	8,2	24,4

TABLEAU 2 Estimation de l'apport annuel de  $^{226}\text{Ra}$  et  $^{238}\text{U}$  sur base d'une application de 75 unités P<sub>2</sub>O<sub>5</sub>.ha<sup>-1</sup> comme fumure d'entretien.

Des études antérieures ont montré (1) que le radium migre très peu dans le sol, on peut donc admettre qu'il reste dans la zone d'application : couche labourée (0-50 cm) et horizon superficiel des prairies (0-10 cm). Si l'on considère le cas d'application de "super" simple, la teneur en  $^{226}\text{Ra}$  est respectivement de 2,4 pCi/kg de sol labouré et de 13 pCi/kg sol de prairie.

En utilisant les valeurs du facteur de passage sol-plante (1), la contamination de divers aliments d'origine végétale a été calculée et figure dans le tableau 3. Par ailleurs l'apport en  $^{226}\text{Ra}$  à l'herbe résultant de l'application annuelle de "super" simple est estimé être de 0,6 pCi/kg matière sèche. Or le rapport observé R.O. (lait/herbe) est de 0,01 (2) ce qui permet d'estimer le niveau de contamination du lait produit par les vaches pâturant l'herbe ayant 0,6 pCi/kg matière sèche, à  $10^{-3}$  pCi  $^{226}\text{Ra}/\text{l}$ .

Etant donné que l'exportation du  $^{226}\text{Ra}$  par la production végétale est très faible (< 0,1%/an), on peut considérer qu'après 50 années consécutives d'application, les teneurs du sol, des végétaux et du lait seront 50 fois plus élevées.

L'ingestion annuelle de  $^{226}\text{Ra}$  provenant de ces produits agricoles est indiquée dans le tableau 3, cette ingestion étant basée sur le régime alimentaire moyen de la population belge (3).

Aliment	Quantité consommée (kg.an <sup>-1</sup> .individu <sup>-1</sup> )	Teneurs en $^{226}\text{Ra}$ (pCi/kg Mat.fraîche)		Ingestion annuelle pCi $^{226}\text{Ra}$	
		Après 1 an d'applicat.	Après 50 ans d'applicat.	Après 1 an d'applicat.	Après 50ans d'applicat.
Lait	131,4	0,001	0,05	0,13	6,6
Légumes	56	0,17	8,5	9,5	476
Pommes de terre	122	0,01	0,5	1,2	61
Céréales (grains)	81	0,036	1,8	2,9	146
Total				13,7	690

TABLEAU 3 Estimation de l'ingestion annuelle de  $^{226}\text{Ra}$  provenant d'aliments produits sur un sol sableux, légèrement humifère, recevant une fumure annuelle d'entretien de 75 unités  $\text{P}_2\text{O}_5 \cdot \text{ha}^{-1}$ , sous forme de superphosphate simple.

Selon les données de la C.I.P.R. pour l'exposition continue des travailleurs, la CMA eau est de  $10^{-7}$  Ci  $^{226}\text{Ra}/\text{m}^3$  ce qui correspond à une ingestion journalière de 220 pCi soit 80 nCi par an; une ingestion continue de  $^{226}\text{Ra}$  à ce niveau conduit, après 50 ans, à une dose effective à 1'os de 30 rem/an. La C.I.P.R. recommande pour la population dans son ensemble le 1/30 de la valeur de l'exposition professionnelle, soit donc une ingestion maximale admissible de 2,7 nCi par an dans le cas présent.

L'ingestion annuelle de 690 pCi de  $^{226}\text{Ra}$  provenant d'aliments (tableau 3) représente environ 25% de niveau admissible recommandé par la C.I.P.R. pour la population et correspond à une dose individuelle de 250 mrem/an à 1'os.



#### 4. DISCUSSION ET CONCLUSION.

Les ingestions de  $^{226}\text{Ra}$  mentionnées dans le tableau 3 sont relatives aux aliments produits dans une zone sablonneuse mais dans le cas d'apport d'engrais phosphaté, en quantité égale, à un sol brun acide, par exemple, le niveau de contamination des aliments sera environ 9 fois plus faible en raison de la fixation plus intense du  $^{226}\text{Ra}$  par le sol, diminuant ainsi la disponibilité de transfert vers le végétal.

En ce qui concerne la contribution relative des divers aliments considérés, on constate que la contribution la plus élevée est constituée par les végétaux consommés comme tels (légumes et farine); la contribution due aux tubercules de pommes de terre est moins prononcée et celle due à la consommation de lait représente environ 1% de l'activité totale ingérée.

A titre de comparaison, l'ingestion annuelle de  $^{226}\text{Ra}$  par le régime alimentaire, évaluée par Michelson (4) pour la diète totale de quatre villes des Etats-Unis est de 1100 pCi; le maximum étant de 1600 pCi et le minimum de 800 pCi. En Allemagne (5), Muth estime l'ingestion journalière à 3 pCi soit une valeur analogue à celle des Etats-Unis.

En conclusion, contrairement aux scories basiques, les engrais phosphatés préparés à partir des phosphates minéraux contiennent par "carry-over" une quantité non négligeable de  $^{226}\text{Ra}$ , ce qui peut entraîner une augmentation de l'exposition de la population notamment par transfert le long de la chaîne alimentaire de ce radionucléide ostéotrope.

#### REFERENCES

- (1) KIRCHMANN, R., LAFONTAINE, A., CANTILLON, G., BOULENGER, R. "Etude du cycle biologique parcouru par la radioactivité", BLG 477 (fév.1973).
- (2) KIRCHMANN, R., VAN DEN HOEK, J., VAN PUYMBROECK, S., "Rapport observé, en conditions naturelles, entre les teneurs de l'herbage et du lait en radiostrontium et en radium". Actes du Congrès International sur la radioprotection du milieu devant le développement des utilisations pacifiques de l'Energie Nucléaire. Toulouse 357-367 (1967).
- (3) CANTILLON, G.E. "Archives belges de Médecine Sociale" Médecine du Travail et Médecine Légale, n°1 (1968).
- (4) MICHELSON, I. "Radium-226 in the total diet", Health Physics 5 229 (1961).
- (5) MUTH, H., RAJEWSKY, B., HANTKE, H.J., AURAND, X. Health Physics 2 239 (1960).

## RADIATION EXPOSURES IN THE FLORIDA PHOSPHATE INDUSTRY

W.A. Mills, R.J. Guimond, and S.T. Windham  
Office of Radiation Programs  
U.S. Environmental Protection Agency  
Washington, D.C. 20460

### 1. INTRODUCTION

Studies of natural uranium and thorium in phosphate ores produced in the United States indicate that concentrations of these natural materials range from about 10 to 400 ppm and 2 to 20 ppm, respectively (1,2). In the rich marine phosphite deposits of Florida, uranium is present in concentrations in the range 100-150 ppm. Uranium daughters in the phosphate ores, at least through radium-226, are usually in secular equilibrium.

The purpose of present studies of this industry by the U.S. Environmental Protection Agency is to assess the radiological impact of phosphate mining, processing, use, and related activities. The study includes an evaluation of the effectiveness of controls and, in areas where controls appear to be insufficient, the development of appropriate standards and guides. This paper summarizes findings to date.

### 2. OVERVIEW OF THE INDUSTRY'S OPERATIONS

In 1974, the total U.S. production of marketable phosphate rock was about 46 million tons with approximately 80 percent coming from the Florida phosphate industry (3). Consequently, the large scale operations of this industry in one regional area may lead to several types of impact on the environment. At present, the domestic marketable phosphate rock production accounts for about 40 percent of the total world production.

The standard mining practice in Florida is to strip the overburden and mine the phosphate matrix. Approximately 5000 acres of land are mined per year in Florida. At the beneficiation plant, the matrix is processed to upgrade its  $P_2O_5$  concentration. The output materials from this operation are marketable phosphate rock, sand tailings and slimes. These materials are produced in a 1:1:1 ratio. Table 1 lists the uranium, thorium, and radium-226 activities for these materials.

TABLE 1: Natural Radioactivity Concentrations in Florida  
Phosphate Mine Products and Wastes (pCi/gm)

Material	Ra-226	U-238	Th-230	Th-232
Marketable Rock	42	41	42.3	0.44
Slimes	45	44	48	1.4
Sand Tailings	7.5	5.3	4.2	.89

Mined-out areas are used for the disposal of sand tailings and slimes, in addition to overburden. Several Florida slime ponds have discharges to the environment. Since most of the radioactivity in the beneficiation wastes is present in the slimes, the concentration of radium-226 was determined for slime. The concentration of dissolved radium-226 was less than 5 pCi/liter at all facilities. The undissolved radium-226 concentration ranged from 10 to 2000 pCi/liter and was highly dependent on the total suspended solids in

the slimes. Although no chemical process is used to treat the discharge from the slime ponds, concentrations of radium-226 in effluents were all less than 3 pCi/liter. The reduction of total radium-226 from the raw slime to the effluent ranged from 92 percent to greater than 99.9 percent. This was primarily due to the removal of suspended solids by settling.

Marketable phosphate rock from Florida is processed into two major products, fertilizers in "wet process" phosphoric acid plants and elemental phosphorus in electric furnace plants. In the "wet process" phosphoric acid plant, phosphate rock is mixed with 93 percent sulfuric acid. This reaction produces phosphoric acid and gypsum. Following the reaction in the attack vessel, the mixture is filtered and the separated gypsum is pumped to a large pile where it is allowed to dewater. Since approximately 4 metric tons of gypsum are produced per ton of phosphoric acid, a large phosphoric acid plant would produce about 2.5 million metric tons of gypsum per year (4). Approximately one percent of the radium-226, 60 to 80 percent of the thorium-230, and 80 percent of the uranium in phosphate rock are dissolved by this acid process.

Table 2 lists the average radioactivity concentrations for the fertilizer products and phosphogypsum by-product of several wet-process type facilities in Florida. Phosphoric acid samples were found to contain from 50,000 to 100,000 pCi/liter uranium-238 and less than one pCi/liter radium-226. The concentration of uranium appears to vary directly with the concentration of  $P_2O_5$ .

TABLE 2: Natural Radioactivity Concentrations in Materials Produced from Florida Phosphates (pCi/gram)

Material	Ra-226	U-238	Th-230	Th-232
Normal Superphosphate	21.3	20.1	18.0	0.6
Diammonium Phosphates	5.6	63	65	0.4
Concentrated Superphosphate	21	58	48	1.3
Monoammonium Phosphates	5	55	50	1.7
Phosphoric Acid*	<1	25.3	28.3	3.1
Gypsum	33	6	13	0.3

\*29 percent acid.

Each "wet process" phosphoric acid plant incorporates a large cooling pond (~500 acres) of contaminated water for recycle in the facility. During periods of excess rainfall it becomes necessary to discharge water from these ponds to nearby streams. Raw process water was found to contain approximately 50 to 90 pCi total radium-226 per liter and approximately 400 to 2000 pCi/liter of uranium-238. To prepare process water for discharge to the environment, the pH must be increased from 1.5-2.0 to 6-9. To accomplish this, slaked lime is normally added. Our studies have shown that this treatment is highly effective in removing radionuclides from the effluent. Radium-226 reductions of greater than 96 percent were observed, with similar reductions in uranium and thorium. As a result of the effectiveness of this treatment, the Agency's permits for phosphoric acid plants usually stipulate an acceptable pH range of 6-9 for treated effluent which ensures minimization of radioactivity discharges.

In the thermal (electric furnace) processing of phosphate rock, silica and coke are added; this mixture is reduced to form elemental phosphorus. Ferrophosphorus and calcium silicate slag by-products are also formed in the

process. Most of the uranium and radium-226 activities in the input phosphate rock are transferred to slag.

### 3. RECLAIMED LAND USE

Approximately 100,000 acres of land have been mined for phosphate rock in Florida. To date, about 25,000 acres of the mined lands have been reclaimed for residential and commercial development, farming, and grazing (5). It is estimated that about 1000 structures have been built on these lands. Since reclaimed lands are composed of overburden, leach zone material, matrix, sand tailings, and/or slimes, they frequently contain radium-226 concentrations substantially higher than the 0.1 to 3 pCi/gram typical of U.S. soils. Concentrations up to 98 pCi/gram have been measured in these reclaimed soils. However, radium-226 concentrations in the reclaimed land soils generally range between 10 to 30 pCi/gram to depths greater than 20 feet. A considerable quantity of radon-222 is produced. This radon-222 diffuses to the ground surface and through the foundations of structures leading to build-up of short-lived radon daughters. Average indoor radon daughter levels over a one-year period were obtained for several structures selected at random on reclaimed land and on land distant from the phosphate region. These data are summarized in Table 3.

TABLE 3: Percentage Range of Radon Daughter Levels

<u>Reclaimed Land (n=13)</u>	<u>Nonreclaimed Land (n=9)</u>
0.05 to 0.1 WL : 38%	0.05 WL : -0-
0.01 to 0.05 WL : 31%	0.01 to 0.05 WL : 22%
0 to 0.01 WL : 31%	0 to 0.01 WL : 78%

We believe that the potential excess lung cancer risk associated with the higher levels, warrant additional studies to define the scope and magnitude of this problem. Based on the assumption that excess lung cancers will double per 60 CWLM exposure, we can associate the highest annual average working level observed, of 0.1 WL for continuous occupancy and an average lifetime (70+ years), with a 6 to 10 times increase in lung cancer. The estimate of the doubling dose is based on the excess cancer observed in uranium miners. If, as seems likely now, the doubling dose is lower for a general population, the estimated health risk would be proportionately greater, possibly by as much as a factor of 2.

### 4. PRINCIPAL EXPOSURE PATHWAYS

There are numerous pathways which could cause exposure to the public due to operation of the Florida phosphate industry. These include exposures resulting from effluents, emissions, ground waters, using the industry's products and by-products, living and working on reclaimed land, and working in the industry. The normal effluents from phosphate mine slime ponds and phosphoric acid plants are readily controllable to limit total radium-226 discharges to surface waters to less than 3 to 4 pCi/liter. It is highly unlikely that such discharges would result in excess radium-226 concentrations greater than 0.5 pCi/liter downstream. However, accidental failure of slime pond dikes could significantly increase the radium-226 concentrations at user points.

Many shallow well water supplies in Central Florida contain radium-226 concentrations greater than the limit of 5 pCi/liter radium-226 and radium-228 contained in EPA's Safe Drinking Water Regulations. However, it is uncertain to what extent the levels are due to the natural presence of uranium in phosphate ores or to operations of the industry.

Data collection and evaluation of air emissions from elemental phosphorus and phosphoric acid plants are incomplete. However, there are some preliminary indications that significant quantities of Po-210 may be emitted from these facilities due to volatilization during calcining or furnace operations.

Workers in the phosphate operations come in close contact with large amounts of phosphate ores, products, and wastes along with inhalation of dust generated by unloading, crushing, drying, and other activities. The highest potential exposures were observed in areas of high dust concentrations in and around the phosphoric reactor vessel. It has been estimated that direct gamma dose equivalents for workers range from 30 to 300 mrem/yr (6). The maximum potential dose equivalent rate to the lungs is about 5 rem/yr. However, using corrections for occupancy this dose equivalent rate is reduced by at least a factor of ten. We do not believe workers in the phosphate industry are being exposed at levels greater than radiation protection guides for the general population. However, we do see a need for more prudent "good housekeeping" measures, particularly with respect to dust levels in various operations.

Population exposures to the indoor radon daughters in structures appear to be the most significant public health problem, and efforts are being made to develop radiation protection guidelines to control exposures to this source. As an interim measure we have provided the State of Florida a screening level which allows continued land development without a significant health impact. This interim guideline is based on a gamma exposure of less than 10  $\mu$ R/hr (including background) which can be associated with a guesstimate of a radon daughter level less than 0.01 WL.

Other aspects of the industry which require further study include the impact of using by-product slag and gypsum for construction materials, the uptake of radionuclides by crops due to fertilizer use or growing on reclaimed lands, evaluating control technologies to limit indoor radon daughter levels, and assessing the impact of recovering uranium fuel from phosphate materials. Efforts are being made to complete scoping of the radiological impact of this industry and to controlling this impact when necessary.

#### REFERENCES

- (1) MENZEL, R.G. "Uranium, Radium, and Thorium Control in Phosphate Rocks and their Possible Radiation Hazard," J. Agr. Food Chem., Vol. 16, No. 2, pp 231-234 (1968).
- (2) GUYMOND, R.J., WINDHAM, S.T. "Radioactivity Distribution in Phosphate Products, By-Products, Effluents, and Wastes, ORP/CSD-75-3, USEPA, Washington, D.C. (August 1975).
- (3) STOWASSER, W.F. "Phosphate Rock," 1974 Bureau of Mines Mineral Yearbook, preprint, USDoI, Washington, D.C. (1976).
- (4) SLACK, A.V., ed. "Disposal or Use of Gypsum," Phosphoric Acid, Vol. 1, Part III (1968).
- (5) OFFICE OF RADIATION PROGRAMS: "Preliminary Findings - Radon Daughter Levels in Structures Constructed on Reclaimed Florida Phosphate Land," Technical Note ORP/CSD-75-4, USEPA (September 1975).
- (6) WINDHAM, S.T., PARTRIDGE, J., HORTON, T. "Radiation Dose Estimates to Phosphate Industry Personnel," EPA-520/5-76-014, USEPA, Montgomery, Alabama (1976).

## RADIOLOGICAL CONTROLS FOR CONSTRUCTION MATERIALS

M.C. O'Riordan and G.J. Hunt  
National Radiological Protection Board  
Harwell, Didcot, Oxon, England

## SUMMARY

The building industry requires large quantities of low-cost raw materials, and industrial or extractive by-products are increasingly used as substitutes for natural aggregates. This practice may be beneficial in many ways, but it can also create radiological problems.

These problems are reviewed with particular reference to British experience. This relates especially to the question of phosphogypsum (a by-product of the manufacture of high-grade fertilizers from uraniferous phosphate rock) in which radium activity concentrations can be of the order of 20 pCi/g. The need for radiological controls is explored in relation to the expected increment in whole-body and lung doses as a result of using such material in credible configurations in typical housing stock.

The difficulties of effecting controls in such a large and diverse operation as the building industry are examined, and the impact of such controls is assessed.

## 1. INTRODUCTION

The construction industry in the UK uses enormous amounts of materials. In recent years, about 200 M tonnes per year of sand and gravel, crushed rock, cement, brick, and gypsum were required (1)(2). As a result, quarries and pits and mines scar the countryside, and there are adverse effects on agricultural production and amenities, although these are minimised as far as possible by planning conditions. At the same time, other industries produce large quantities of solid wastes, probably about 100 M tonne per year (3), which present disposal difficulties. Chief among these are the coal, electrical power, china clay, metallurgical and phosphate industries.

Natural aggregates are conserved and overall environmental effects mitigated by the use of wastes for construction purposes. There can also be economic and technical benefits from such practices including saving in energy consumption (4). About a quarter of the wastes are indeed utilized, and uses deserving research and development or increased application have been identified (3).

## 2. BUILDING MATERIALS

The radioactivity content of materials used in the construction of habitable buildings markedly influences the radiation doses to which persons are subjected. This refers both to external irradiation and to the inhalation of airborne radioactivity. Mean activity contents of traditional building materials and of materials with established usage that contain wastes are given in Table 1. Values are only indicative in most instances, because sampling is not complete. The lightweight blocks examined were made mainly from the wastes generated at coal-fired power stations.

Material	No. of samples	Mean activity content pCi g <sup>-1</sup>		
		<sup>40</sup> K	<sup>226</sup> Ra	<sup>232</sup> Th
Granites	7	3.0	2.4	2.2
Sand and Gravel	10	0.9	0.1	0.2
Cement	6	4.2	0.6	0.5
Bricks	25	19	1.4	1.2
Natural Gypsum	73	3.8	0.6	0.2
Lightweight blocks	10	10	1.6	0.7

TABLE 1 Activity content of building materials (5)(6)

From the evidence available, the activity contents of these blocks appear to be comparable to those of traditional materials such as bricks; consequently, the doses incurred because of their utilization are no different from those historically incurred.

### 3. PHOSPHOGYPSUM

In recent years, the UK building industry has shown interest in utilizing waste phosphogypsum. This material is a by-product in the manufacture of phosphoric acid from sulphuric acid and phosphate rock by the wet acid process. The calcium sulphate may be obtained in various degrees of hydration, but dihydrate is exclusively produced in the UK (7). The process may be represented by the equation:

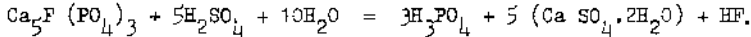

About 2 M tonne of phosphogypsum is produced each year. Virtually all of it is dumped at present, 80% by slurry pipeline to seas and estuaries and 20% dry on land.

Phosphate ores imported into the UK are mainly sedimentary in origin and have relatively high contents of uranium and its decay products. Mean activity contents of the phosphate rock and of phosphogypsum arisings are listed in Table 2.

Material	No. of samples	Mean activity content pCi g <sup>-1</sup>		
		<sup>40</sup> K	<sup>226</sup> Ra	<sup>232</sup> Th
Phosphate rock	31	5.9	38	1.3
Phosphogypsum	60	1.1	17	0.5

TABLE 2 Activity content of phosphate rock and phosphogypsum (5)(6)

The <sup>226</sup>Ra content is well above the normal values for building materials, whereas the <sup>40</sup>K and <sup>232</sup>Th values are about the same. It is possible therefore to assess the situation in terms of the extra dose resulting from the excess <sup>226</sup>Ra content of phosphogypsum compared with the materials in Table 1. So as to accommodate reasonable variations in the activity contents of the ores from the principal exporting countries, an excess <sup>226</sup>Ra content of 25 pCi g<sup>-1</sup> was considered for the radiological evaluation described below; this implies about 42 pCi g<sup>-1</sup> in the ore if radium followed the behaviour of calcium in the foregoing equation.

For over 30 years, phosphogypsum had been used in the UK to make hemihydrate for plastering and for plasterboard (3) but production ceased around 1970 due to difficulties in controlling the qualities of the  $\beta$ -hemihydrate produced. Because of the nature of these applications and the limited utilization of the waste, this practice did not arouse radiological concern.

New interest centred on the manufacture of glass-reinforced gypsum (GRG) and plaster blocks for internal walling from the  $\alpha$ -hemihydrate. This crystalline form of the hemihydrate could also be used for making board. In the manufacture of  $\alpha$ -hemihydrate by continuous process, phosphogypsum had a direct cost advantage over natural gypsum, and many of the impurities causing technical difficulties with the  $\beta$  form could be eliminated (7).

GRG is a patented material with excellent mechanical properties; for some applications, the use of  $\alpha$ -hemihydrate instead of  $\beta$ -hemihydrate results in a stronger product. It also has excellent fire resistance and would partly compete with asbestos cement products thus reducing a proven hazard. GRG can be made into sheet form or into a wide range of components. The blocks can be made to exact dimensional standards and would require no further surface treatment before decorating; thus the costs of plastering could be eliminated and productivity in home building greatly improved. There are also possibilities for the use of phosphogypsum in the manufacture of cements.

#### 4. ASSESSMENT

In assessing the radiological implications of using phosphogypsum, the dose increases resulting from its liberal use in a typical house were determined (9). The model chosen was a two-storey three-bedroom centre terrace house with a floor area conforming to national guidelines on space in the home. This type of house provides some 30% of the accommodation in the UK (10). It was assumed that over 4.2 tonnes of phosphogypsum was used to replace all the non-lead bearing conventional partitions, and that all the ceilings were made of phosphogypsum plasterboard. Measurements and calculations of the beta- and gamma-ray dose rates were made, and the radon emanation from the phosphogypsum components was determined.

With a nominal excess of  $25 \text{ pCi g}^{-1} \text{ }^{226}\text{Ra}$  in phosphogypsum compared to the conventional materials, the excess beta-ray dose to the superficial tissues, less than 20 mrad in a year, could be dismissed. The increase in gamma-ray dose to the occupants of the model house, 0.03 rad in a year, roughly equals the regional variations in average dose within the UK, and the increase in radon daughter exposure, 0.04 WLM in a year, is well within the range of natural variations. On the basis of an estimate of 10% for the rate of market penetration by phosphogypsum, the increase in average gonad dose after a generation would be less than 1% of the national average, given the rate of replacement of housing in the UK.

In view of the advantages offered by phosphogypsum, the proposed uses were deemed acceptable, but because of the speculative nature of the estimate of future usage, it was considered prudent to record production, utilization, and activity contents and also to review the developing situation periodically. This qualified acceptance required the elaboration of a system of reporting and reviewing to which the term controls is applied.

#### 5. CONTROLS

The structure of the proposed controls is as follows. For building components such as blocks, boards, partitions, ductings, and mouldings, manufacturers would provide a physical description. For each product line, they would also provide the annual production rate and geographical destination, radioactivity contents to an agreed testing schedule, and recommended



finishes. Phosphogypsum to be used as a constituent in cement would also be controlled but with a less elaborate physical description.

Apart from the radioactivity measurements, which would be relatively infrequent and inexpensive, manufacturers would not incur any significant costs in complying with the controls, since all the data required for radiological purposes would be available for commercial and technical reasons.

As for the controlling authority, no difficulties in monitoring the situation on a voluntary basis are envisaged because of the compact structure of the phosphoric acid industry in the UK and the degree of cooperation existing between building material producers and government agencies.

The burden of such controls both on producers and on the controlling authority is likely to be light in this instance if the proposals come to fruition.

#### REFERENCES

- (1) DEPARTMENT OF THE ENVIRONMENT, Monthly statistics of building materials and components, No. 18, August 1976. London, DOE.
- (2) ARCHER, A.A., "Sand and gravel as aggregate". London, HMSO (1972)
- (3) GUTT, W., et al. "A survey of the locations, disposal and prospective uses of major industrial by-products and waste materials", CP 19/74, Watford, Building Research Establishment (1974)
- (4) SMITH, M.A., "The economic and environmental benefits of increased use of pfa and granulated slag", CP 41/75, Watford, Building Research Establishment (1975)
- (5) HAMILTON, E.I., The relative radioactivity of building materials. Am. Ind. Hyg. Ass. J. 32 (1971) 398
- (6) NATIONAL RADIOLOGICAL PROTECTION BOARD, HPMR Reports, (1973-1976)
- (7) GUTT, W., SMITH, M.A., Utilization of by-product calcium sulphate. Chem. & Ind., July (1973) 610
- (8) MONOPOLIES COMMISSION, "Plasterboard. A report on the supply of plasterboard". London, HMSO (1974)
- (9) O'RIORDAN, M.C., et al. "The radiological implications of using by-product gypsum as a building material". NRPB-R7, Harwell, National Radiological Protection Board.
- (10) GOVERNMENT STATISTICAL SERVICE, Social Trends, No. 7, London HMSO (1976)

CONCENTRATION OF RADON (RN-222), THORON (RN-220) AND  
THEIR DECAY-PRODUCTS INSIDE BUILDINGS - MEASURING  
DEVICES AND PRELIMINARY RESULTS

A. Wicke, J. Porstendörfer, H.C. Scheibel, A. Schraub  
Institut für Biophysik, Leihgesterner Weg 217,  
D-6300 Giessen, West-Germany

## 1. INTRODUCTION

Many attempts have been made to evaluate the concentrations of radon, thoron and their daughters in our natural radiation environment in respect for estimating the resulting adsorbed dose. Especially there is an increasing interest about conditions inside houses, because you know that there are generally higher concentrations compared with outdoors (1-5). Some of these publications show, that the actual amount of radon and thoron present in the room-air depends upon the exhalation of the construction materials, the geometry of the room, the ventilation-rate and outdoor concentrations. A few of these parameters are influenced by meteorological variables (5-8).

Our interest is to carry out a series of measurements of radon, thoron and their daughters in- and outside of certain buildings and to study the main factors influencing it such as exhalation, ventilation and aerosol conditions. Parallel we try to describe the situation by an appropriate model (9), which is based upon the calculations of HULTQVIST (1). If this model is applicable in general, it is possible to compute the concentrations of the radioactive aerosol as well as the resulting absorbed dose (15,16). One must only know the meteorological and aerosol conditions, the properties of the construction materials and the geometry of the room.

## 2. THEORETICAL CONSIDERATIONS

Our calculations show, that the inside concentration of thoron is rather independent from outdoor conditions, in contrast to radon. Radioactive equilibrium does not exist between radon and its decay-products, because there is always a great deposition of the unattached daughters upon the walls. The fraction of the free atoms is only important for ThA ( $f=100\%$ ) and PaA ( $f=2-12\%$ ). The difference between the concentration of RaR and RaC (RaC') for usual ventilation conditions ( $0.1 - 1.5 \text{ h}^{-1}$ ) is very small as well as the difference between ThB and ThC (ThC') (5-15%).

## 3. EXPERIMENTAL ARRANGEMENT

### 3.1 Radon-222

The concentration of Pn-222 was determined by adsorption of the air to be examined at cooled activated charcoal ( $-78^\circ\text{C}$ ).

	$e_{Rn}$ [ $\frac{pCi}{h \cdot m^2}$ ]	$v$ [ $h^{-1}$ ]	$c_{RaA}$ [ $\frac{pCi}{l}$ ]	$c_{RaC}$ [ $\frac{pCi}{l}$ ]	$c_{ThC}$ [ $\frac{pCi}{l}$ ]	D [mrad/a]	
						T- B	P
Po1	145	1.1 0.1	0.25 2.80	0.13 1.10	0.06 0.24	46	39
Wi1	245	0.7	0.60	0.28	0.24	71	123
Rs1	145	0.4 2.4	0.30 0.15	0.05 0.03	0.19 0.03	27	65
Hi1	250	0.06 0.5	2.50 1.0	0.90 0.38	0.10 0.10	57	49
Bo1	280	0.3	1.50	0.5	0.17	52	45
St1	105	0.5	0.60	0.1	0.1	30	37

TABLE 1 Preliminary results

Subsequent desorption by heating (450°C) was followed by transferring the Rn-222 into a scintillation cell ("Lucas-Chamber", (10)). After three hours (Rn-222 in secular equilibrium with its short-lived daughters), the scintillation pulses were detected by a phototube and counted by a scaler. The detection limit of this method is about  $10^{-14}$  Ci/l.

### 3.2 Radon-220

The concentration of Rn-220 was measured using a large-surface flow-type scintillation chamber (11). An alpha-alpha coincidence arrangement only detects such pulses which belong to the decay of ThA.

### 3.3 Radon-Daughters

To measure Rn- and Tn-daughters separately (RaA, PaC', ThC') we use a surface-barrier detector for alpha-spectroscopy (12). The radioactive aerosols were deposited on a membrane-filter (air-flow 3.8 m<sup>3</sup>/h) and simultaneously detected by a collimated surface-barrier detector (900mm<sup>2</sup>). The system has an energy-resolution between 200 - 250 keV and an efficiency of 6%.

### 3.4 Ventilation

Looking at the theoretical results, ventilation is one of the most important parameters. We realized to measure the air-exchange by filling the room up to 1% CO<sub>2</sub>. The slope of the decrease of concentration with time was used to determine the ventilation rate (13).

### 3.5 Exhalation

We only measured the exhalation of Rn-222. The method was such, that we put a small chamber with fresh charcoal on the wall to gather the exhaling Rn-222 (14). After one hour the accumulated radon was desorbed by the previous mentioned method. The detection limit of this method is about 10 pCi/m<sup>2</sup>.h.

## 4. RESULTS

We studied the conditions in- and outdoors at several sites. Each room was observed for at least four days to regard daily variations. For dose estimations we take the assumptions of JACOBI (16) at a mean ventilation of 0.5 air-changes per hour. A survey over the most important results is shown in table 1.

#### REFERENCES

- (1) HULTQVIST, B., Kungl. Sven. Vet. Handl. Fj. Ser., Band 6, Nr. 3 (1956).
- (2) DUGGAN, M.J., D.M. HOWELL, Int. J. Appl. Radiat. Isot. 19 (1968) 865.
- (3) TOTH, A., Health Phys. 23(1972)281.
- (4) GEORGE, A.C., in: The Natural Radiation Environment II, Proceedings, Houston, Texas, 1972, 741.
- (5) STEINHÄUSLER, F., Health Phys. 29(1975)705.
- (6) GABRYSH, A.F., F.J. DAVIES, Nucleonics 13, No 1(1954)50.
- (7) JONASSEN, N., Health Phys. 29(1975)216.
- (8) KRISIUK, E.M., S.I. TARASOW, V.P. SHAMOV, N.I. SHALAK, E.P. LISACHENKO, L.G. COMELSKI, Report of the Research Institute for Radiation Hygiene, Leningrad, 1971.
- (9) WICKE, A., J. Porstendörfer, Proceedings of IRPA Amsterdam 1975, C 13.
- (10) LUCAS, H.F., Rev. Sci. Inst. 28, No 9 (1967)680.
- (11) BOGEN, J., M. SAPPOCK, C. SCHUMANN, Arch. Met. Geophys. Biokl., Ser. A, 21(1972), 171.
- (12) MARTZ, E.D., D.F. HOLLEMAN, D.E. McCURDY, K.J. SCHIAGER, Health Phys. 17(1969)131.
- (13) GEORCII, H.W., Arch. Met. Geophys. Biokl., Ser. B, 5(1954)191
- (14) MECUMI, K., T. MARMURO, J. Geophys. Res. 77(1972)3052.
- (15) JACOBI, W., Health Phys. 23(1972)3.
- (16) JACOBI, W., in: Die natürliche Strahlenexposition des Menschen, Thieme 1974, Stuttgart, 118.

This paper was prepared in connection with work under the research project 603, sponsored by the Bundesministerium des Innern.

## THE RADIOLOGICAL TESTING OF PRODUCTS WHICH IRRADIATE THE PUBLIC

M.D. Hill and A.D. Wrixon  
National Radiological Protection Board  
Harwell, Didcot, Oxon, England

### 1. INTRODUCTION

Radiological protection tests play an important part in the work of the National Radiological Protection Board in advising manufacturers, distributors and government departments on the acceptability of products which can lead to exposure of the public to ionising radiations. The Board's approach to testing and two examples of its application are described in this paper.

### 2. THE ROLE OF TESTING IN DECISION - MAKING

Radiation doses from any product which irradiates the public must not exceed appropriate ICRP Dose Limits. This is an overriding requirement but the proper application of the ICRP system of dose limitation to decisions on whether a product is acceptable involves two processes: justification by risk-benefit analysis and optimisation so that doses from the product are as low as is reasonably achievable. An acceptable product is one which has been both justified and optimised. Risk-benefit analysis involves assessments of the doses expected from the product when it is in normal use and when it is accidentally damaged or abused. Consumer products are effectively outside any form of centralised control after sale to the public; for this reason potential doses as a result of some form of recovery after disposal by their original user must also be considered. Rigorous but realistic testing provides the basic information needed for these assessments. The principal role of testing in optimisation is to obtain information on a range of comparable products. Data of this kind can indicate the design features necessary to minimise risks, and are thus useful when formulating radiological protection standards for products.

### 3. APPROACH TO TESTING

In addition to measurements of external radiation dose rates and source leakage in normal conditions, tests should include evaluation of a product's performance under adverse temperature, mechanical and corrosion conditions. These tests can be designed in two ways: they can either simulate the damage likely to be suffered by a product in the environment in which it is used, or they can simulate the environment itself. There are problems inherent in both methods and usually a combination of the two is used. Where little or no information is available it is necessary to make some assumptions about the types of accident which could occur, and the adverse environmental conditions which are likely to be encountered. The Board's approach is to develop tests on a case-by-case basis since flexibility is essential when dealing with a wide range of products and environments.

### 4. TEST PROGRAMMES AND RESULTS

#### 4.1 Ionisation Chamber Smoke Detectors

The test programme for ionisation chamber smoke detectors (ICSDs) can be divided into two parts; three tests are related to normal use and the remainder to credible accidental damage or abuse (1). The tests intended to simulate adverse environmental conditions and accidental damage are summarised in Table 1. Each test is carried out on a separate detector or

source/holder combination to avoid the difficulty of interpreting the results of combined tests.

Type of test	Parameters	Part of detector tested	Damage or environment simulated
1. Temperature	-25°C to +100°C	Source and holder	Damage due to ambient temperature variations
2. External pressure	25 kPa to 100 kPa	Source and holder	Pressure variations during air transport
3. Impact	0.5 kg from 0.5 m	Whole ICSD	Damage from accidental blows
4. Drop	From 10 m	Whole ICSD	Accident during installation or servicing
5. Puncture	1 g from 1 m	Source and holder	Damage due to tampering with source
6. Vibration	5 - 60 Hz	Whole ICSD	Damage due to ceiling vibration
7. SO <sub>2</sub> Corrosion	16 days exposure	Source and holder	Corrosion in industrial atmosphere
8. Humidity	10 days exposure	Source and holder	Corrosion in non-industrial atmosphere
9. Special test: Fire	1. 600°C 2. 1200°C	)Source, holder )and parts of )detector )housing	1. Typical domestic fire 2. Hot industrial fire

TABLE 1 Test Programme for ICSDs

The majority of ICSDs now available use <sup>241</sup>Am foil sources. Measurements have confirmed that external radiation levels are very low, even for the highest activity detectors (100 µCi <sup>241</sup>Am). Preliminary wipe tests of sources and inactive parts of ICSDs have shown that amount of removable contamination are very small if suitable precautions are taken during manufacture. In general, the temperature and mechanical tests caused no increase in the amounts of removable activity on sources and their surroundings. After exposure to sulphur dioxide only the high activity ICSDs gave more than 5 nCi on wiping.

In the 600°C fire test the results of wipes over the sources range from an undetectable amount of activity to several hundred nanocuries (see Table 2). There is a clear correlation between the amounts of removable activity and the source holder material, stainless steel and aluminium holders giving much more satisfactory results than brass or tin-plated ones. In most cases the ICSD debris was not contaminated and no activity became airborne.

The results of this exploratory test programme have provided information which will be valuable in establishing criteria for acceptance of ICSDs. The 600°C fire test, with a requirement that not more than 5 nCi activity should be detectable in the debris and removed by wiping the source and

Holder material	Pre-test wipe (nCi)	Post-test wipe (nCi)	Comments
Stainless	NDA - 1.0 NDA	NDA - 3.0 97 - 345	Fire retardant ABS plastic housing caused higher leakage
Aluminium	NDA - 1.3	0.01 - 4.3	
Tin plated mild steel or brass	NDA - 0.2	10 - 409	
Brass	NDA - 0.06 0.08	12 - 15 120	Solder used for fixing foil contributed to higher leakage

NDA = no detectable activity ie, less than 10 pCi

TABLE 2 Results of 600°C Fire Test on ICSDs with <sup>241</sup>Am Foil Sources

holder after the test, has become one of the bases used by the Board for acceptance of ICSDs and is recommended for general use.

#### 4.2 Radioluminous Compasses

In contrast to the extensive testing programme devised for ICSDs, when the Board carried out a systematic survey of compasses which are or have been available to the United Kingdom public, only external dose rates and removable activities were measured. The results of these simple tests were sufficient to enable the Board to make a number of recommendations on design features of compasses which would reduce doses to the public from these devices in both normal and accident conditions. These recommendations are:

- If radioluminous paint is used it should be sealed (with varnish) and covered with transparent material. This reduces dose rates and prevents loss of activity (the latter can be a problem with paints containing <sup>3</sup>H).
- In the case of paints containing <sup>147</sup>Pm the transparent cover should have a thickness equivalent to at least 50 mg cm<sup>-2</sup> (0.4 mm perspex). This thickness is sufficient to reduce dose rates to acceptable levels.
- Luminising with gaseous tritium light sources (GTLs) is preferable to using radioluminous paints. If GTLs are used they should be inaccessible. Covering GTLs reduces the external dose rate and minimises the possibility of accidental breakage.
- Paints containing <sup>226</sup>Ra should no longer be used. Because of the external  $\gamma$ -radiation and high radiotoxicity of <sup>226</sup>Ra, it should no longer be used in radioluminous paints.
- The use of non-radioactive luminous paints should be encouraged.

#### REFERENCES

- (1) HILL, M.D., WRIXON, A.D. and WILKINS, B.T., Radiological Protection Tests for Products which can lead to Exposure of the Public to Ionising Radiation, National Radiological Protection Board, NRPB R42 (1976)



## QUALITY CONTROL WORKSHOPS IN NUCLEAR MEDICINE

Peter Paras, Donald R. Hamilton and  
Richard J. Van Tuinen

U.S. Food and Drug Administration  
Bureau of Radiological Health  
5600 Fishers Lane  
Rockville, Maryland 20857

## 1. INTRODUCTION

The United States Food and Drug Administration's (FDA) Bureau of Radiological Health (BRH) has begun a program to improve the degree of quality control in nuclear medicine. This program is designed to incorporate the quality control activities of several professional organizations with the programs of certain accreditation and governmental agencies. There is also an effort being made to implement quality control programs in medical institutions through the development and presentation of workshops. These workshops are primarily directed to the practicing nuclear medicine technologist but have had success in reaching the physician and health physicist as well.

## 2. BACKGROUND INFORMATION

In nuclear medicine, the interpretation of static images and dynamic function studies is often critically dependent upon the quality of the images and data generated by the equipment and techniques used. This dependence exists because significant changes in the condition of the patient frequently are reflected as very subtle changes in the images barely above the threshold of detectability. Suboptimal equipment or techniques may cause these subtle changes to fall below the threshold and pass unnoticed by the physician. For this reason it is essential that nuclear medicine equipment and procedures be maintained at an acceptable level of performance at all times.

Because of these needs, authorities such as the Joint Commission on Accreditation of Hospitals, the United States Public Health Service and the Social Security Administration having responsibility for delivering good health care in the U.S.A. have recognized the importance of conducting "quality assurance" procedures by requiring that measures be installed and recorded regularly in support of accreditation or licensure of nuclear medicine services. Also, other government agencies and professional organizations have recognized the need for quality assurance test procedures in nuclear medicine and have encouraged voluntary implementation.

This encouragement has helped identify the need and now effort has begun to be directed towards the standardization of test procedures and the delineation of adequate programs for the administration of a quality assurance program in a clinical nuclear medicine facility. Furthermore, efforts have been directed towards the development of an implementation mechanism to encourage adoption of quality assurance procedures in clinical nuclear medicine facilities throughout the United States.

Quality assurance in nuclear medicine is important from at least two viewpoints: (1) reliability of diagnostic information, and (2) legal

requirements having to do with accreditation or licensing. It is involved in three broad areas: instrumentation, clinical and laboratory procedures and patient records. Complete failure of an instrument is, of course, immediately apparent; however, the gradual degradation of diagnostic information through equipment malfunction cannot be ascertained without specific testing procedures. Evaluation of every aspect of the performance of the scintillation camera, for example, is a complex process requiring the use of sophisticated test equipment and time consuming procedures. In this case, for daily evaluation of camera performance by the nuclear medicine technologist, test procedures are needed which are relatively simple and can be performed quickly. These procedures should provide an index of the overall quality of camera operation, rather than an explicit identification of malfunctioning components which will assume optimal instrument performance.

### 3. QUALITY CONTROL WORKSHOP

To address these problems, the BRH has initiated a short term training program for implementation of quality assurance in nuclear medicine directed primarily to technologists. The program is presented in the form of workshops consisting of seminars and classroom instruction followed by demonstrations and supervised "hands on" experience in quality control test procedures.

Clinical nuclear medicine activities requiring quality control have been grouped into areas and categories, as follows:

- A. Area of imaging instrumentation:
  - 1. Scintillation cameras
  - 2. Rectilinear scanners
- B. Area of radioisotopes:
  - 3. Handling, control and calibration
  - 4. Radipharmaeetical preparations
- C. Area of in vitro tests:
  - 5. Instrumentation and procedures
- D. Area of advanced instrumentation
  - 6. Computer utilization and interface
  - 7. Emission tomography systems

A two-day workshop is designed for each category. Instruction materials and specific self-explanatory protocols (cook-book type); for each procedure and type of instrument are developed for use by participants; attending the workshops. The pertinent materials for each category are published in the form of a manual by the BRH and will be periodically revised to reflect new developments and input from concerned professional organizations.

The responsibility of the administration of each workshop is vested in a local workshop director selected for his knowledge of nuclear medicine and his interest in quality control. He is assisted by the workshop coordinator, who will, if necessary, visit the workshop location prior to the program. The coordinator is responsible for selecting the geographical location, assigning priorities, soliciting the workshop director and participating in the instruction. The local workshop director is responsible for announcing and directing the workshop, for securing adequate physical facilities, and for suggesting faculty for all parts of the workshop.

The BRH coordinates the overall effort of the nationwide series of workshops and arranges individual workshops through the assistance and participation of FDA's Regional Radiological Health Representatives and the Society of Nuclear Medicine.

### 3.1 QUALITY CONTROL OF SCINTILLATION CAMERAS WORKSHOP

The initial regional workshops (Denver, Colorado) served as a pilot study for the quality control protocols and workshop format and helped their development into a more polished format prior to national distribution. At the same time the manual was also tested for completeness according to the needs of the participants, reviewed by professional organizations, edited and then published in final form. Topics covered in the manual are as follows: introduction to quality control of scintillation cameras, evaluation of scintillation camera performance, history and evolution of the scintillation camera, introduction to scintillation camera operation, daily quality control tests flow sheet, apparatus for quality control procedures, image recording media for scintillation cameras, preparation guide for Cobalt-57 flood phantom, construction guide for a parallel line equal spacing (PLES) phantom, and protocols for quality control procedures for specific scintillation cameras.

The workshop program notes that qualitative measurement tests of three parameters can furnish an adequate index, in most cases of scintillation camera performance. These parameters are: (1) uniformity, (2) spatial distortion, and (3) resolving power. The relatively simple procedures adopted by BRH require only 15 minutes and are included in the manual as protocols. A suitable source and a proper transmission bar phantom are the only requirements. The source may be either a point source or a disk source, preferably made from either technetium-99m or cobalt 57 for procedures using radiopharmaceuticals emitting low energy photons. Any transmission phantom which can cover the field of view can be used in combination with the source. Commercially available phantoms which are satisfactory for this assessment include the 90° bar quadrant phantom, Nine-Duiley phantom, and the parallel line equal spacing (PLES) phantom developed by BRH. Instructions for constructing a PLES phantom are included in the workshop manual.

The two-day program has been designed to meet all the needs for an adequate review of all procedures in this area. The first day consists of seminars and discussions of materials contained in the workshop manual while the second control procedures on scintillation cameras similar to those in their own institutions. Each participant is asked to perform the tests under the supervision of one of the workshop faculty, usually in combination with a technologist from the

participating hospital.

Letters are sent to attendees after the program to determine the effect of the workshops on their quality control program at their home institution.

### 3.2 QUALITY CONTROL OF RADIOPHARMACEUTICALS AND RADIONUCLIDE HANDLING

The BRH, through a contract, arranged for pilot workshops and followed the usual pattern of drafting, reviewing and editing of the workshop manual. Topics covered in the manual are as follows: radionuclide generators, quality control of radionuclide calibrators, quality control procedures for radiopharmaceuticals, handling of radioxenon, and radiation safety in nuclear medicine.

The workshop program covers radionuclide generators from aspects of physical design and operation, calculation of yields and activity, and eluate contamination. The section on dose calibrators discusses tests of accuracy, geometry and linearity while the portion on radiopharmaceuticals reviews microbiological testing, chromatography and related tests. The xenon section provides information on various breathing systems, collection and disposal of the gas, and patient procedures. Radiation safety concerns itself with exposure control, personnel monitoring, use of syringe shields, and handling of contamination and radioactive waste. Recommendations for testing of radiopharmaceuticals and dose calibrations are provided in the manual and laboratory protocols are provided separately for "hands-on" experimentation.

### 3.3 OTHER WORKSHOPS

The remaining workshops in the list are in various stages of design and development. The quality control workshop on rectilinear scanners has had the pilot programs presented and the manual is being reviewed. The workshop on in vitro procedure is under contract and pilots are being planned.

## 4 RESULTS

The message of initiating a quality control program for scintillation cameras and subsequently the extension of the concept to other areas of nuclear medicine has been successfully transmitted through these workshops. Our desire to motivate individuals through education to adopt the procedures voluntarily has been fulfilled and follow up surveys have indicated a wide acceptance of the recommended practices and adoption of quality control programs in nuclear medicine departments.

## TWO SUCCESSFUL ACTION PROGRAMS FOR DOSE REDUCTION IN DIAGNOSTIC RADIOLOGY

Richard E. Gross

Bureau of Radiological Health, Food and Drug Administration

Rockville, Maryland 20857

## 1. INTRODUCTION

A paper reviewed (in a rapporteur session) at the Third International Congress of the International Radiation Protection Association, at Washington, D.C., examined the health physicists' role in the health care environment, stressing their potential for effecting exposure reduction through close working relationships with other health and allied health professionals.(1) This paper reports on two programs that demonstrate the success of such an approach.

Diagnostic x-ray examinations include three separate tasks:

1. selection of the patient,
2. performance of the examination, and
3. interpretation of the results.

Of course, physicists can have their greatest impact by improving the performance of the examination. Selection of the patient and interpretation of a properly conducted examination are the responsibility of the physician or radiologist.

The two programs discussed here were developed to help radiation control agencies at the Federal, State, and local levels to efficiently manage their efforts to reduce unnecessary exposure from dental and breast x-ray examinations.

## 2. DENTAL EXPOSURE PROBLEM

In 1972 a pilot study was conducted to identify the causes of high exposure in dental radiology and to test an educational approach for reducing unnecessary exposure (2). Survey data were collected on 110 x-ray units (72 dental offices) selected at random. The data showed that many offices overexposed films and reduced developing time. About one-third of the offices used sight development instead of the recommended time-temperature processing technique. Dental consultants visited the offices 2 months after the surveys to present findings and demonstrate needed improvements in radiographic practice. In 1973, a followup survey was conducted to determine the effectiveness of the consultation visits. Mean exposure per film was 542 mR in 1972 and 340 mR in 1973. This reduction of approximately 38 percent indicates the effectiveness of an educational approach to achieve significant reduction in unnecessary radiation exposure.

## 3. THE DENTAL EXPOSURE NORMALIZATION TECHNIQUE (DENT) PROGRAM

This exposure reduction and quality assurance program was developed through a joint State/Federal effort (3). A health agency sends cards containing thermoluminescent dosimeters (TLD's) to all dental x-ray facilities within its jurisdiction. These dosimeters are exposed by the dentists and returned for analysis. Facilities that show excessive exposure are then visited to demonstrate the changes in exposure and processing necessary to produce diagnostic quality radiographs with minimum patient exposure.

#### 4. RESULTS OF DENT

Currently, 37 Federal, State, and local radiation control agencies, responsible for about two-thirds of the dental machines in the U.S., use the DENT program. Twelve of these have completed followup visits in facilities showing excessive exposure. Data reported by nine of these agencies show that approximately 43 percent of the machines evaluated by TLD's were visited because of high exposures. As a result of the followup surveys, the nine radiation control agencies were able to achieve an average exposure reduction of 240 mR per film, or approximately 41 percent. Furthermore, the dentist who follows the surveyor's recommendations for exposing and processing the films will, in general, produce consistently good diagnostic radiographs. Recently the American Academy of Dental Radiology endorsed DENT as an effective exposure reduction and quality assurance program (4).

#### 5. THE MAMMOGRAPHY EXPOSURE PROBLEMS

Several events led to our current concern with exposure from mammography. First was the public awareness of breast cancer after publicized mastectomies on public figures; and the subsequent increase in the use of mammography. Another event was a study of mammographic exposure levels and techniques in Eastern Pennsylvania (5).

Mammography facilities, including 45 hospitals, 23 private radiology, and 2 clinics, were surveyed during routine State compliance inspections. Low energy dosimeters were used to measure the exposure from a single cranio-caudal view, using the technique factors normally employed by the facility for a "medium-density, medium-sized" breast. Mean exposure for the various types of image receptors ranged from 1 to 24 R. Five facilities were apparently overexposing and underdeveloping films, with a resultant mean exposure of 39 R per film, and a high of 47 R. The study concluded that approximately three-fifths of the surveyed facilities had not optimized their mammographic procedures for the x-ray energies and for image receptor development utilized.

This study has brought to light two problems. One, in many cases the exposure per film is unnecessarily high and, two, even if the exposure appears acceptable, the image quality may not be optimal. The second problem is a big one and will require a major cooperative effort on the part of several categories of the health profession to solve. There is still considerable debate regarding the appropriate x-ray energy spectrum for a given image receptor and even regarding which structures in the breast must be visualized.

Using an approach similar to that of the DENT program, we are working to correct the first problem, that of reducing unnecessarily high exposures. Although mammography is more complicated than dental radiography because of difficulties in soft tissue visualization and the large variety of image receptors and x-ray generating equipment, we have demonstrated through pilot tests that a program similar to DENT will be productive when applied to mammography.

#### 6. THE BENT PROGRAM

The BENT (Breast Exposure: Nationwide Trends) program is conducted in the same manner as DENT (6). By contacting and obtaining the support of the

local physicians through the radiological and other medical societies, their cooperation results in high response rates and return of the questionnaire and dosimeters. Once support is obtained, physicians are mailed a questionnaire which is used to identify facilities that conduct mammographic examinations. Those responding affirmatively are asked to identify the number of x-ray units used for mammography and answer some questions regarding the number and age of patients examined.

Then the health agency sends the dosimeter cards to those facilities that conduct mammography exams. The dosimeters are exposed and returned for analysis. Facilities that show either excessive exposures or abnormally low exposures are visited to further evaluate the x-ray unit and image processing system and recommend changes in the mammographic techniques as required.

### 7. RESULTS OF BENT

At the close of 1976 the BENT program initiated trials in 5 States. The results can be summarized as follows:

#### Preliminary BENT Data (4 States)

	<u>All Image Receptors</u>	<u>Direct Exposure Film</u>	<u>Film/Screen Combinations</u>	<u>Xero-radiography</u>
No. of units	401	75	187	139
Percent of units	100	18	47	35
Mean Exposure (R)*	1.5	3.2	0.62	1.8
Minimum Exposure (R)	0.03	0.3	0.03	0.18
Median Exposure (R)	0.51	1.5	0.40	1.1
Maximum Exposure (R)	16.6	16.6	5.0	6.9

\*Exposure is expressed as Roentgens free-in-air at the skin entrance site (6 cm. above the tabletop or equivalent plane) for a single cranio-caudal view.

Followup visits of those facilities with exposures near the minimum and maximum values are still being conducted. Typically, in those cases where the exposures were unusually high, some mistakes were being made with the technique which probably provided a darker than usual image or the exposure was high because of improper film processing, using a very low kVp (26 or less), or insufficient filtration in the x-ray beam. For those cases where the exposures were abnormally low, the radiologists tended to be unhappy with the images and in many cases the image quality was significantly improved by reducing the beam quality for film mammography or by increasing the exposure (for Xerox systems) to a somewhat more normal level.

As a result of the initial trials, the BENT program has been shown to be an effective method for identifying facilities that are using exposures that seem to be inappropriate for mammographic examinations. It results not only in a reduction of exposures that are too high, but also in an improvement of the image quality for those situations where the images might be inferior for the purpose of diagnosis of early breast cancer. The cooperation from the radiologists who have been visited in the program thus far has been encouraging and lead us to believe that the BENT program will be as successful as the DENT program.

## 8. CONCLUSIONS

This paper has reviewed two educational programs that have been successful in reducing significant amounts of unnecessary radiation in the conduct of diagnostic x-ray examinations. The widespread use of these programs will result in a significant reduction of exposure to the population, resulting in better health care. Efforts must continue on an even broader scale to identify the causes of unnecessary radiation exposure and then develop and implement solutions that will eliminate unproductive radiation exposure.

## REFERENCES

1. Gross, R., M. Marks, M. Audet, and J. Benson. "The Role of the Health Physicists in Reducing Medical Radiation." Proceedings of the International Congress of the International Radiation Protection Association (3rd), held at Washington, D.C. on 9-14 September 1973. National Technical Information Service, U.S. Department of Commerce, Springfield, Virginia 22151.
2. Crabtree, C. L., D. N. Johnson, and J. Gibbs "Nashville Dental Project: An Educational Approach for Voluntary Improvement of Radiographic Practice." DHEW Publication (FDA) 76-8011, Supt. of Documents, GPO, Washington, D.C. 20402, 1975.
3. Division of Training and Medical Application "Dental Exposure Normalization Technique (DENT) Instruction Manual." Bureau of Radiological Health, Rockville, Md. 20852, 1975.
4. AADR Newsletter, Vol. 3, No. 4, September 1976, Medical College of Georgia, Augusta, Georgia 30902.
5. Bicehouse, H. J. "Survey of Mammographic Exposure Levels and Techniques Used in Eastern Pennsylvania." Proceedings of the Seventh Annual National Conference on Radiation Control-Assuring Radiation Protection, pp. 136-143. Superintendent of Documents, U.S. GPO, Washington, D.C. 20402, February 1976.
6. Jans, R., et al. "Pilot Tests of a Mammography Quality Assurance Program." Presented at Health Physics Society Annual Meeting, San Francisco, California, June 27-July 2, 1976.



MASS HEALTH PHYSICS SURVEY TECHNIQUES FOR REDUCTION  
OF POPULATION EXPOSURE THROUGH QUALITY ASSURANCE IN  
DIAGNOSTIC RADIOLOGY

Dale E. Starchman, Ph.D., Ronald G. Johnson,  
Ph.D., David L. Hykes, M.S., and Willard J.  
Howland, M.D. Department of Radiology of the  
Northeastern Ohio Universities College of  
Medicine, 2600 Sixth Street, S.W., Canton,  
Ohio 44718 U.S.A.

## 1. INTRODUCTION

Diagnostic exposures of patients contribute more to the genetically significant dose than do all other man-made medical and industrial exposures combined (1, 2, 3). Historical evolution of U.S. legislation stems from concerns about nuclear weapons hazards associated with fissionable materials. This origin gave rise to the phenomenon of virtually unlimited authority and resource availability for regulations involving even minuscule quantities of fission products, with virtually no federal emphasis on medical exposure of patients. State regulation of x-rays modeled after federal non-medically oriented programs, emphasized personnel protection with only token patient oriented regulations. Only recently, largely through the efforts of the Bureau of Radiological Health, have priorities begun to be re-oriented to reflect recognition that subjecting a patient to 1 rem from diagnostic x-rays has much the same effect on the genetically significant dose or carcinogenesis as subjecting a reactor operator to 1 rem from fission products. DNA changes do not respect legislative intent.

In maximizing benefit/cost in routine annual radiation surveys of diagnostic x-ray facilities, we have developed procedures which emphasize the reduction of patient as well as personnel exposure by reducing repeated radiographic procedures and by reducing required fluoroscopy time, which in a sense represents a repetition of previous fluoroscopy time. We apply these procedures to more than 300 medical diagnostic x-ray units in more than 50 radiology facilities ranging from single unit private offices to several 500-700 bed hospitals. The procedures include traditional items required for compliance with State and National requirements and recommendations. In addition, ionization systems are used to determine linearity of exposure per mAs over the entire range of times and currents available on each unit, and the accuracy of kVp is determined over the operating range of each unit. Resolution and other operating parameters are evaluated. The comprehensive survey system requires less than 1½ hours per radiographic or fluoroscopic unit.

## 2. DEVELOPMENT

Each survey and calibration includes procedures required to demonstrate compliance with recognized standards provided by the ICRP and NCRP as well as legal regulations. These will not be described in this presentation. In addition, parameters are measured which have a direct bearing on radiographic quality and hence on the radiographic re-take rate (4, 5). These techniques have been developed over a period of 6 years (6, 7, 8, 9, 10, 11). Measurements of linearity of exposure with time and current utilize an ionization chamber which has been shown not to be dose rate dependent over the range encountered with diagnostic radiology units. Measurements of kVp accuracy are made with the RMI Wisconsin Test Cassette based on the Ardran Crooks method (12, 13, 14, 15). Determination of focal spot sizes are made using the RMI Wisconsin X-Ray Focal Spot Test Tool.

## 3. LINEARITY OF EXPOSURE WITH TIME AND CURRENT

It is assumed in any radiographic examination that exposure is linear with indicated time and current. If one uses 100 mA and 1/10 sec or 200 mA and 1/20 sec, the mAs is the same and the exposure should be the same at a fixed kVp. If time is held constant, exposure should change linearly with mA. If current is held constant, exposure should change linearly with time. We have measured exposure per mAs for all combinations of time and current possible on each unit which will result in more than 1 mAs. The mR/mAs should be a constant. The results on the 150 fixed radiographic units, eliminating portables are shown in Table 1.

Table 1 Distribution of Maximum Variation of mR/mAs

<u>Maximum percent variation of mR/mAs from mean of extremes</u>	<u>percent of 150 units with corresponding % variation</u>
+ 1 - 10%	38%
- 11 - 20%	31%
21 - 30%	15%
31 - 40%	7%
41 - 50%	6%
51% or more	3%
	<hr/>
	100% = 150

New units are not accepted if variation exceeds  $\pm 10\%$ .

## 4. ACCURACY OF kVp

The authors have now tested a total of 150 stationary radiographic x-ray units using the test cassette. The results are shown in Table 2.

Table 2 Summary of kVp Measurement Results for 101 Stationary Radiographic Units

Nominal kVp	Fraction Within $\pm 5\%$	Fraction Within $\pm 10\%$
60 kVp	95/145 = 66%	127/145 = 88%
80 kVp	108/147 = 73%	134/147 = 91%
100 kVp	102/140 = 73%	135/140 = 96%
120 kVp	86/131 = 66%	122/131 = 93%
Total Measurements:		
	391/563 = 69%	518/563 = 92%

New units are not accepted if variation exceeds  $\pm 5\%$ .

#### 5. FOCAL SPOT SIZE

The authors have now tested a total of more than 50 stationary radiographic units using the focal spot tool. Preliminary analysis shows that approximately half of all the focal spots are exactly as indicated by manufacturer and that approximately 90% have an actual/indicated ratio between 0.9 and 1.0 for both large and small focal spots.

#### 6. CONCLUSION

It is possible within an acceptable cost/benefit range to perform all traditional survey items as well as determination of the three major parameters affecting radiographic x-ray unit performance: linearity of exposure with time and current, kVp accuracy, and focal spot size determination. These measurements are being performed on an annual basis on more than 150 stationary diagnostic x-ray units each year. Frequency distributions given above provide a foundation on which to base expected variations and acceptance criteria.

#### REFERENCES

- (1) National Council on Radiation Protection and Measurements, Basic Radiation Protection Criteria, NCRP Report No. 39 (National Council on Radiation Protection and Measurements, Washington, 1971).
- (2) United Nations Scientific Committee on the Effects of Atomic Radiation Reports of the United Nations Scientific Committee on the Effects of Atomic Radiation, General Assembly Official Records: Seventeenth Session, Supplement No 16 (A15216) (United Nations, New York, 1962).
- (3) Gonad Doses and Genetically Significant Dose from Diagnostic Radiology. U.S. 1964 and 1970. DHEW Publication (FDA) 76-8034 (April 1976).
- (4) R.J. Mazzaferro, S. Balter, and M.L. Janower: The Incidence and Causes of Repeated Radiographic Examinations in a Community Hospital. *Radiology* 112, 71-72, July 1974.

- (5) A Study of Retakes in Radiology Departments in two large Hospitals by Burnett, Mazzaferro and Church. DHEW Publication (FDA) 78-8016 (July, 1975).
- (6) D.E. Starchman and R.G. Johnson: Expanded Role of Health Physics Survey in Evaluating Operations and Radiation Safety of Medical X-Ray Units. Presented at the July, 1974 Annual Meeting of the Health Physics Society, Houston, Texas. Abstract published in Health Physics, December, 1974.
- (7) D.E. Starchman, R.G. Johnson and W.J. Howland: A Technique for Rapid Determination of mR/mAs Variation in Acceptance and Calibration of Diagnostic X-Ray Units. Presented at the August, 1975 Annual Meeting of the American Association of Physicists in Medicine, San Antonio, Texas. Abstract published in Medical Physics May/June, 1975.
- (8) James J. Vucich, Quality Assurance: A Fundamental whose Time Has Come. Proceedings of the Society of Photo-Optical Instrumentation Engineers, Vol. 70 Medicine IV (1975).
- (9) D.E. Starchman: Field Testing and Analysis of Diagnostic X-Ray Unit Performance and Quality Control. Seminar presented at Bureau of Radiological Health, Rockville, Maryland, November 21, 1975. Available as 1½ hour videotape and in transcript form from HEW.
- (10) D.E. Starchman and R.G. Johnson: Methods and Results of Survey of kVp Accuracy and of Exposure Linearity for 100 Radiographic Units in U.S.A. Hospitals, presented at the Fourth International Conference on Medical Physics, Ottawa, Canada July, 1976. Abstract published in Conference Proceedings.
- (11) D.E. Starchman, R.G. Johnson, D.L. Hykes, and W.J. Howland: The Role of kVp Accuracy of Diagnostic X-Ray Units and Other Performance Parameters in Quality Assurance. Proceedings of the Society of Photo-Optical Instrumentation Engineers, Vol. 96, Optical Instrumentation in Medicine V(1976).
- (12) D.E. Starchman, R.G. Johnson and W.J. Howland: Determination of Exposure Linearity with Indicated Time and Current for Diagnostic X-Ray Units. Radiology, February, 1977.
- (13) G.M. Ardran & H.E. Crooks Brit. J. Rad. Vol 41(1968).
- (14) G.M. Ardran & H.E. Crooks Brit. J. Rad. Vol 45 (1970).
- (15) Giarrantano, et. al. Med. Phys. Vol. 3, No. 3,(1976).

PATIENT EXPOSURES IN SWEDISH DIAGNOSTIC RADIOLOGY\*

G. Bengtsson, P-G. Blomgren, K. Bergman and L. Åberg

National Institute of Radiation Protection

Fack, S-104 01 Stockholm, Sweden

1. INTRODUCTION

Reviews (1) or collections (2,3) of articles dealing with medical exposure of patients indicate a wealth of reports in the area. Why should you care to read another one?

A) You are interested in the methods to be used for assessing population exposures. So were we. In particular we paid much attention to the sampling inaccuracy in the mean dose to a small group of patients.

B) You wish to reduce the patient dose. We discuss here realistically possible reductions, and the role of collective radiation risk in assigning priorities for such reductions.

C) You want to know the radiation risk to Swedish patients. Probably not, unless you are Swedish (We are!). But you might be interested in a very broad survey, comparing genetic and somatic doses, encompassing all important types of examinations and a large number of hospitals. If you are of a speculative kind, you might conjecture that some trends may be applicable to your own country.

D) You dream of a simple way of monitoring radiation risk to patients. Sorry, there probably is no such goodie. But we discuss why not and suggest a simple monitoring system indicating long-term cancer risk within a factor of 3 up or down at all but a few types of examinations.

May we have your attention? We then regret that the restricted format prohibits presentation of most of the details. A detailed preliminary report is available (4), giving several references to related studies.

2. WHAT IS THE DOSE TO A SINGLE PATIENT ?

The actual dose to a patient in an x-ray examination depends not only on physical factors such as radiation quality or screen-film sensitivity, but also on factors related to the patient such as his weight, and to the personnel such as the experience of the doctor performing a fluoroscopy. It is extremely difficult to assess the total patient dose unless one resorts to direct measurements on series of patients. We measured doses to about 1000 Swedish patients in 13 hospitals, and additionally several photofluorographic and dental installations. The measurements comprised radiation quality, exposure-area product and doses to a few parts of the body where dosimeters could be placed. Calculations yielded energy imparted as well as doses to the thyroid, mammae, lungs, bone marrow, ovaries and testes. These calculations are based on assumptions about projections, field sizes, patient positioning etc which may be strongly in error as far as the individual patient is concerned. The energy imparted should be subject to the least uncertainty, about  $\pm 15\%$ . The mean dose to the organ of an individual patient could in many cases be off by more than a factor of two.

\* Work supported by the Swedish Cancer Society

### 3. WHAT IS THE MEAN DOSE TO A GROUP OF PATIENTS?

When the mean organ dose to a group of patients is assessed the sampling errors tend to be very large, since there are considerable management difficulties in extending the measurements to more than 10 or 20 patients, and the standard deviation of individual organ doses is sometimes above 100 %.

We concluded that we were interested in two types of mean doses to a group of patients. One is the true arithmetic mean which describes the actual irradiation of the group and is relevant e. g. to risk assessment.

The other is the "typical" patient dose which may be more useful in comparative studies. We found that the use of the arithmetic mean of the two middle quartiles as a "typical" dose facilitated significantly, in most cases, the comparison of doses between two groups. The middle quartile mean was closely approximated by the geometric mean. Some care in its employment is required, however, since the arithmetic mean was up to 4 times above the middle quartile mean and proving differences less than a factor of 2 requires considerable effort.

### 4. POSSIBLE REDUCTION OF PATIENT DOSES

We have compared the arithmetic mean doses to groups of patients examined under different conditions, e. g. at different hospitals (Table 1).

Examination	Ratio of "highest" and "lowest group"				
	Energy imparted	Mean absorbed dose to			
		Thyroid	Mammae	Ovaries	Testes
Hip					3.7
Pelvis	3.0				10
Lumbar spine	3.5		6.2	4.3	26
Urography			14		17
Stomach	5.1	8.2	5.0	14	
Colon		4.0		3.5	13
Hysterosalpingography	4.6			3.2	
Gall bladder			11	4.3	>7
Dorsal spine			3.4		
Lung (full size)		6.6			
Lung(photofluorography)	6.0				
Lung plus heart			3.1		
Cervical spine		4.5			
Dental intraoral	23	7.5		>60	>60

TABLE 1. Highest observed ratios of the radiation load to patient groups examined under different conditions e. g. different hospitals or personnel. All patients were not studied for all types of radiation doses. Only ratios of 3 or above are entered.

In principle, it should in most cases be possible for all groups to attain the lowest dose observed for any group. There is little probability that this dose is too low to give sufficient information, since almost all of the radiology is supervised by well trained radiological specialists. Thus it can be safely concluded that there is much room for dose reduction. Often the overall radiation level can be reduced, as indicated by the energy

imparted. Frequently, careful attention to shielding can significantly reduce the dose to various organs involved. Using already available techniques, the energy imparted, thyroid dose, mammary dose and ovary dose to the Swedish population could probably be reduced to about one-half, and the testes dose to less than one-third of the present average level. The collective risk can be used in assigning priorities for this reduction. We have, for instance, given much weight to dose reductions in photo-fluorography which was very dominant regarding cancer risk.

#### 5. WHAT IS THE RADIATION RISK TO THE SWEDISH POPULATION?

We have estimated the collective doses to the Swedish population from all types of medical and dental examinations in 1974.

A very crude risk estimate (Table 2) based on recent data (1,5) indicates a risk of about 10 radiation induced cancer deaths annually per million inhabitants, and about the same number of individuals born with serious genetically related injuries. (The latter could be a significant overestimate (6).) This would represent an addition of less than 1 per cent to the normal risks.

Organ	Mean annual collective dose per individual, mGy	Assumed number of injuries per million man-gray	Annual harm commitment, injuries per million individuals
Thyroid	0.75	1000	0.75
Mammae	0.54	6000	3.2
Lungs	0.64	2000	1.3
Bone marrow	0.92	3000	2.8
Ovaries	0.68		
Testes	0.65		
Whole body	1.00	15000	15
Genetically significant dose	0.4-0.8	15000	6-12

TABLE 2. Estimates of collective dose and risk to the Swedish population from all medical exposures 1974. The injuries referred to are the total number of induced cancers which lead to death, and in the case of genetic injury the total number of future children born with serious genetically related injuries.

A cancer risk estimate along the same lines indicates the following risk of cancer death per million examinations: 10 to 50 at some less frequent examinations such as cardiovascular angiography and further at the following examinations in order of increasing risk: urethrocytography, small intestine, head, stomach, lumbar spine, pelvimetry, lung photo-fluorography, colon, retrograde pyelography, urography, cerebral angiography and doreal spine; below 0.1 at single dental exposures and examinations involving femur, lower legs and arms; 1 to 10 at all others. No examinations yielded a risk estimate between 0.1 and 1.

#### 6. MONITORING RADIATION RISK TO PATIENTS

As we have stressed before, any estimates of radiation doses and risks to patients not being based on direct measurements are subject to many errors. The perspective of devoting man-years to patient measurements is, however, discouraging. Can simplified relations relax the measurement burden?

We discuss below two possibilities. For completeness, we also wish to mention without any comments, that the overall mean value of energy imparted to patients per unit film area was  $0.39 \text{ J/m}^2$ , excluding dental, photofluorographic and image intensifier camera film.

#### 6.1. Exposure-area product and bone marrow dose.

The active bone marrow is distributed over almost the whole body. In a crude approximation it is uniformly distributed over a certain projected body area, and its mean dose can be given as a certain fraction of the entrance dose. The mean marrow dose would then be proportional to the exposure-area product. This approximation seems to bear little relation to reality. Surprisingly enough, detailed calculations at lung exposures and dental exposures yielded a marrow dose within 20 % of that given by the approximation, and cruder estimates indicated an approximation within a factor of 2 at all types of examinations except those involving the lumbar spine, stomach or gall bladder as well as urographies. Crude estimates indicated that at lumbar spine examinations one-half of the constant of proportionality applicable to most examination types would apply, and at urographies one-fifth.

#### 6.2. Energy imparted and cancer risk.

The cancer risk calculated using the assumptions in Table 2 was for each of the various types of examination compared with the energy imparted. (Alternatively, the exposure-area product could be used yielding about the same degree of approximation.)

Examinations of the extremities again seemed to bear relatively little radiation risk. All other types of examinations yielded a risk of 0.0001 cancer deaths per joule, within about a factor of 3 up or down. Any closer tentative risk estimate is hardly justified, bearing in mind the uncertainty of the basic estimates of cancer risk per unit absorbed dose.

In contrast, the ratio of gonad dose and energy imparted extended over a range of 3 decades, as compared to the 1 decade range of the cancer risk ratio. The energy imparted or exposure-area product are thus poor indicators of genetic risk.

#### REFERENCES

- (1) UNSCEAR (United Nations Scientific Committee on the Effects of Atomic Radiation). Report 1972. Radiation levels and effects, Vols. I and II, United Nations, New York (1972)
- (2) IAEA. Population dose evaluation and standards for man and his environment. (STI/PUB/375) Proceedings. International Atomic Energy Agency, Vienna, (1974)
- (3) IRPA. Third international congress of the international radiation protection association. (CONF - 730907 - P 1) USAEC, Oak Ridge, Tennessee (1974)
- (4) BENGTESSON, G, et al., Patient exposures in Swedish diagnostic radiology. Report SSI:1976-013, National Institute of Radiation Protection, Stockholm (1976)
- (5) BEIR (Advisory Committee on the Biological Effects of Ionizing Radiations). The effects on populations of exposure to low levels of ionizing radiation, National Academy of Sciences - National Research Council, Washington, D.C. 20006, (1972)
- (6) ROYAL COMMISSION ON ENVIRONMENTAL POLLUTION (Chairman Sir Brian Flowers). Sixth report: Nuclear power and the environment. HMSO, London (1976)



RADIATION EXPOSURE OF THE ITALIAN POPULATION DUE TO MEDICAL  
DIAGNOSTIC EXAMINATIONS IN 1975

S. Benassai, M. Curatolo, F. Dobici  
CNEN, Direzione Centrale per la Sicurezza Nucleare e la  
Protezione Sanitaria, Roma, Italia

P. L. Indovina, L. Pugliani, P. Salvadori  
Laboratorio delle Radiazioni, Istituto Superiore di  
Sanità, Roma, Italia

## 1. INTRODUCTION

Radioprotection in diagnostics and therapy is a serious problem: since no radiation dose limits are generally fixed for medical procedures; therefore, in this field more than any other care must be taken to reduce contributions to the total dose due to causes which are uncalled for or beyond control. To this end, systematic inspections are needed, on the one hand, to point out possible apparatus and protection deficiencies. On the other hand, pedagogical campaigns must be carried out so that users and patients appreciate this matter in its real importance: users, in pursuing the desired benefits, should pay utmost attention to minimizing the risk of harmful radiation effects; patients should be aware of the risks associated with radiation in order to avoid incessant examination when no clear indication for this exists. In addition, adequate regulations must be established to eliminate undue exposure, without limiting the physician's judgement.

In order to meet these ends the Italian authorities responsible for radioprotection recently started two research projects. On the inspection side, with BRH assistance the Istituto Superiore di Sanità and the CNEN adapted the NEXT program to national requirements: in such a way a substantial improvement in X-ray diagnostic techniques and methodology could be achieved. On the educational side, in addition to other promoting steps, they started an investigation of X-ray and radiopharmaceutical use in diagnostics, in order to ascertain their real importance and, consequently, to intervene in eliminating possible misuse. A first inquiry concerned radiation exposure of the Italian population due to medical diagnostic examinations in 1974: results, presented at the Levico Terme AIFSPR Congress in 1975, are now in press in Health Physics. Subsequently, another investigation referring to 1975 was started on the same subject, preliminary results of which are here discussed.

It should be kept in mind that, as a consequence of serious lack of organization, it is really difficult for the diagnostic

centers to answer the questions properly, according to the radio protection requirements. Therefore, results are in some sense uncertain, representing an order of magnitude more than an accurate evaluation of the genetically significant dose to the Italian population in 1975. Furthermore, it should be considered that in the X-ray dose estimates average current available values were used (sometimes implemented through experimental "ad hoc" measurements), since it is neither realistic nor desirable to measure doses in each procedure.

## 2. X-RAY DIAGNOSTICS

Through an inquiry at the major X-ray film manufacturers, a consumption of 80,000,000 films in 1975 was ascertained (dental films excluded), with an 8% increase compared with 1974 (0.7% is the estimated corresponding increase in population). On the other hand, a questionnaire regarding number and type of X-ray examinations carried out in 1975 was sent to Regional Authorities who distributed it to the X-ray diagnosis centers.

Seven out of twenty regions, representative of about 30% of the Italian population, answered the questionnaire. Of these regions one provided data concerning more than 99% of examinations carried out, another contributed only 10%, while the remaining regions supplied informations on about 35% of examinations estimated. Therefore, even if examinations reviewed made up only 12% of the total, the geographical distribution qualifies them as a representative sample (the 10% contribution from one region being discarded).

On these grounds Table 1 was compiled: about a 28 mrem contribution to the genetically significant dose for the Italian population in 1975 results, a 10.5% increase compared with that of 1974.

Table 1

Examination	Contribution to genetically significant dose/mrem
Cardio-vascular apparatus	0.003
Gastro-intestinal apparatus	5.64
Urinary apparatus	2.98
Respiratory apparatus	0.06
Skeletal apparatus	15.25
Obstetric and Gynaecological X-rays	4.05
Dental X-rays	0.02
TOTAL	28.00

### 3. DIAGNOSTIC USE OF RADIOPHARMACEUTICAL

In order to estimate the contribution to the genetically significant dose from the use of radioisotopes in nuclear medicine, appropriate questionnaires were sent out to approx 700 known users of diagnostic radiopharmaceuticals practising in Italy (in vitro and therapeutical uses were excluded from polling) with the scope of obtaining informations regarding type and number of examinations performed.

About 15% of questionnaires was returned. Because of the low number of answers obtained a sampling method was used in acquisition of data concerning the distribution of patients according to their sex and age; in this view data relative to about 85,000 patients and constituting about 17% of the total patient bulk were evaluated as a representative fraction and taken into account.

The evaluation of the number of examinations performed in 1975 was effected taking advantage of the availability of data concerning the investigation relative to 1974; the increase in the examinations performed in 1975 in comparison to 1974 was estimated by a sampling method too. There appeared to be an increase of about 23%.

As for the calculation of the gonad dose received by the patients for every  $\mu\text{Ci}$  of administered radioisotope, reference was made to the ICRP data, or those reported in other recent studies.

It can be estimated that in 1975 about 490,000 persons were subjected to radioisotope diagnostic examinations which contribute to the genetically significant dose with a total value of 0.57 mrem.

Moreover some interesting problem of radiation protection arises because of the fact that the same type of examination may be performed by the use of different techniques. The circumstance along with the fact that the dosage of a given radioisotope varies from user to user are of major importance with regard to the dose received by the patient and, consequently, with regard to his protection and the genetical dose. A comparison of data relative to 1974 and to 1975 indicated in some cases a tendency to perform examinations in order to reduce the dose received by the patient: this is the case, for example, of thyroid and renal scanning, by substituting with  $^{99\text{m}}\text{Tc}$  respectively  $^{131}\text{I}$  and  $^{203}\text{Hg}$  or  $^{203}\text{Hg}$ .

From the answers obtained, the most used techniques are thyroid and iodineuptake, radio renogram, liver scan, brain scan, whereas the greatest contribution to the total relation load comes from pancreatic scan, thyroid uptake and scan, brain scan.

#### 4. CONCLUSIONS

From the foregoing evaluations it can be concluded that for 1975 radiographic examinations and radiopharmaceutical use on the whole contribute to the Italian population genetically significant dose to the extent of about 28.5 mrem. In this evaluation fluoroscopy, in addition to some specialistic examinations, is not taken into account. A rough estimation leads to a 2.5 mrem contribution for fluoroscopy, taking into account the moderate diffusion of this technique in the country, frequently associated with brilliance intensification.

Therefore, the genetically significant dose to the Italian population due to diagnostic medicine examinations in 1975 can be said to be of the order of 31 mrem. From this value one can deduce that in Italy, as in other countries, radioprotection in medicine is a true problem, so that many efforts are necessary to cut down undue exposure. In particular, unnecessary repetition of examinations must be avoided, this being frequent when a patient changes from one physician to another or from one diagnostic center to another. That is why national authorities, in addition to the above-mentioned steps, are urging that X-ray doses, as in the case of radioisotopes, be compulsorily recorded on the radiation personal medical card, so that all previous examinations are accurately listed.

NATIONWIDE EVALUATION OF TRENDS IN X-RAY EXPOSURE  
OF MEDICAL PATIENTS IN ISRAEL

A. Donagi, Y. Leser\*, M. Nave and A. Lichter

Research Institute for Environmental Health,  
Ministry of Health and Sackler School of  
Medicine, Tel-Aviv University, Israel

A national surveillance program of X-ray machines in Israel is carried-out by the Israeli Ministry of Health since 1965. The surveillance system covers all diagnostic, therapeutic and dental X-ray machines in the country.

Until recently the surveillance program was designed and performed for the purpose of pointing out equipment not complying with the appropriate Israeli radiation hygiene standards. Simultaneously, exposure of the personnel was evaluated and preventive measures taken. In the last years it was concluded that in addition to the routine measurement of standard parameters it is essential to include in the survey-routine additional parameters, directly relevant to the exposure of the patient himself.

Following a careful investigation of possible techniques to achieve this goal the NEXT program was found to be the most suitable one.

The NEXT (Nationwide Evaluation of X-ray Trends) program was initiated in 1971 by the Bureau of Radiological Health (BRH) of the United States Public Health Service (USPHS). Participation of Israel in this project began in 1974.

One of the major goals of the NEXT program is to supply the users with reliable information concerning exposure-doses given to a "standard" patient, throughout performance of radiographic examinations. To meet these needs the BRH developed an Organ Dose Index System (ODIS), which incorporates specific computer program based on technical information and measured data.

Data are collected as follows:

During the inspection of representative X-ray machines (selected on a statistical basis) the inspector determines which of the standard diagnostic procedures included in the NEXT schedule, if any, are performed. The most frequent procedure, routinely carried-out by the machine is chosen. The X-ray operator is asked to set the technique (milliamperage, kilovoltage, exposure time, target-to-film distance, collimation, etc.) relevant to this procedure for a patient possessing certain standard anthropometrical characteristics (1, 2). A standard testing-device, especially designed for this project, is used for measuring the physical parameters concerning the specific procedure. All the measurement results, as well as technical and other data, are recorded on a special form. This information is transferred to the BRH and fed into a computer system, where organ dose and skin entrance exposure indexes are calculated.

---

\*Present address: Medical Physics Institute, Radiotherapy Division,  
Beilinson Hospital, Petah Tiqva, Israel.

Procedure	No. of Surveys	Exposure Parameters					Dose Indexes			
		KVP	mAs	HVL mmAl	Source Film Distance inches	Beam Size inches	Skin Entrance Exposure mR	Surface Exposure Integral Rxc <sup>2</sup>	Ovarian Dose Index mrad	Testicular Dose Index mrad
Chest P.A.	30	60-105 (55-125)	5-50 (3-50)	1.3-5.6	64-86 (35-120)	10x10 - 29(circ.) (11x14 - 27x32)	3-75 (3-75)	3-200	<0.5-4	<0.5
Abdomen (KUB) A.P.	55	56-105 (60-95)	32-320 (25-150)	1.6-4.7	36-48 (29-49)	10x13 - 18x25 (11x14 - 23x27)	170-2000 (100-750)	90-2050	20-160	1-940
Lumbo- Sacral Spine A.P.	32	60-90 (60-95)	30-240 (30-200)	1.4-3.4	39-48 (29-73)	5x12 - 19.5(circ.) (6x12 - 34(circ.))	220-1600 (100-1500)	75-800	25-140	<0.5-32

TABLE 1: Ranges of Exposure Parameters and Dose Indexes, Observed in Various Facilities in Israel (compared to "Post-Edit Criteria").

Procedure	First Quartile mR	Median mR	Third Quartile mR	Mean mR
Chest P.A.	14 (11)	17 (16)	21 (26)	17 (22)
Abdomen (KUB) A.P.	390 (380)	528 (530)	659 (730)	593 (600)
Lumbo-Sacral Spine A.P.	395 (450)	511 (700)	735 (1100)	641 (810)

TABLE 2: Weighted Values for Exposure at Skin Entrance, by Type of Examination, as Calculated in Israel (Compared to the Values Obtained in U.S.A. (3)).

During the period August 1974 - May 1976, 102 various X-ray tubes were surveyed in Israel within the framework of the NEXT program. The most common diagnostic procedure for each of the tubes was investigated. In some cases, two procedures per machine were investigated. All together about 150 projections were included in the project. At this stage of the program no investigation of dental machines was carried-out.

The investigations were performed in about fifty various medical institutions, which were selected among about 200 non-dental institutions spread all over the country.

The main findings, collected and measured throughout this stage of the NEXT program are summarized in Table 1. The table also includes the ranges of NEXT Post-Edit Criteria, which are used as indexes for evaluating the reliability of the results.

Table 2 presents the weighted median indexes by type of examination (in the brackets, relevant values, measured during the years 1972-1975 by the BRH in the USA, are given; these values were taken from a recent communication (3)).

It could be seen from Tables 1 and 2 that both the exposure-parameters and the standard patient radiation doses are quite widely dispersed (there is a considerable dispersion among the various institutions and even among the machines and tubes at the same institute). Throughout the investigations it was realized that the considerable spread of the various results stems from inherent variations in the irradiation and development equipment (e.g. type of machine, filtration, film, grid, intensifying screen, etc.), as well as from differences in the working methods (e.g. collimation, darkroom procedures, etc.). The considerable spread of the testicular doses measured throughout abdomen A.P. radiographs, could be explained also by the fact that the testes might or might not be located within the primary beam.

Table 2 shows also that the weighted median indexes, calculated for chest P.A. and abdomen A.P. procedures in the Israeli facilities are quite similar to those obtained in the USA. However, comparison of the same indexes for the lumbosacral A.P. procedure, shows that Israeli values are considerably lower than those of the USA. This difference could be explained by the fact that considerable collimation is common for this procedure in Israel. (Comparison of actual beam sizes with the "Post-Edit Criteria" in Table 1 confirms this point).

Table 3 presents few examples whereby the NEXT project contributed for the improvement of radiation hygiene. Exposure parameters as well as skin doses observed before and after the introduction of a specific change are indicated.

Facility Identification	Procedure	Type of Investigation	KVP	mAs	Skin Entrance Exposure mR	Type of Modification
K 1	Abdomen A.P.	Before Modif.	81	160	1570	Tube was replaced
		After Modif.	73	160	750	
H 8	Skull Lat.	Before Modif.	66	120	325	Universal screen was replaced by High Speed screen
		After Modif.	66	60	170	
H 6	Abdomen A.P.	Before Modif.	80	150	1220	Manual development was substituted by automatic development
		After Modif.	65	100	590	
K 7	Lumbo-Sacral Spine A.P.	Before Modif.	70	160	1600	Manual development without heating was replaced by development with heating
		After Modif.	70	80	670	

TABLE 3: Examples of Modifications, Adopted for Reduction of Patient Dose.

It could be concluded that the NEXT program besides being a useful tool for providing up-to-date statistical data regarding average exposure levels of the diagnostically investigated population, helps in pointing out extreme cases where modifications might be most useful. At present, the possibility of including some of the NEXT techniques as a control method complementing the national routine surveillance system, is being investigated.

#### REFERENCES

- (1) SHAVER, J.W., HARDIN, C.M. and LUBENAU, M.S., Nationwide Evaluation of X-ray Trends, in: Quality Control in Medical X-Ray, DHEW Publication (FDA) 74-8002 (1973).
- (2) NATIONWIDE EVALUATION OF X-RAY TRENDS: Organ Dose Index System-Instruction Manual for NEXT Participants, DHEW Publication (FDA) 77-8006 (1976).
- (3) BRH-Private Communication (April 1976).



ORGAN DOSES AND INTEGRAL DOSES IN X-RAY DIAGNOSIS  
OF THE CHEST AND OF THE HEAD

H.Pauly, Th.Schmidt, and G.Hasl

Institut für Radiologie der Universität Erlangen-Nürnberg  
Krankenhausstraße 12, D-8520 Erlangen

## 1. INTRODUCTION

The basis for the evaluation of the somatic risk due to the exposure in x-ray diagnosis is the knowledge of the organ doses and the integral doses in the patient and the knowledge of their frequency and distribution in the population. The dose measurements presented in this paper are concerned with the dose distribution and the integral doses (energy imparted) of standard x-ray examination of the chest and of the head by radiographic films. These types of examination are most frequently done in diagnostic radiology. They probably contribute to a large degree to the radiation exposure and to the somatic risk due to diagnostic radiology.

## 2. EXPERIMENTAL SEKTION

### 2.1 X-ray generator

The radiation source was a x-ray tube P 125/20/40 (Siemens AG., Erlangen, West Germany). The voltage was generated by a two peak generator (Ergophos 2, Siemens AG., Erlangen, West Germany). The maximum voltage respectively short time tube current is according to the manufactures 125 kV and 100 mA. The inherent filtration of the x-ray tube and the light beam localizer was equivalent to 2 mm Al.

### 2.2 Phantom

The dose distribution was measured in an Alderson-Man-Phantom corresponding to an "average man" with a mass of 73.5 kg and a length of 175 cm. The phantom, developed for radiation therapy, allowed the measurement of the dose distribution in a three dimensional network with a width of mesh of 3 cm in transversal and 2.5 cm in axial direction. For one exposure from 200 to 1000 LiF dosimeters were distributed in the phantom.

### 2.3 Dosimetry

Cylindrical LiF-rods of 6 mm length and 1 mm diameter from Harshaw Company, Solon, Ohio, USA, were used. The rods were introduced into a special cylindrical detector holder from lucite of 25 mm length and a diameter of 6 mm. The LiF-rods enclosed in lucite were calibrated for all radiation qualities used by comparison with a thimble ionizing chamber (Siemens Universaldosimeter), calibrated at the "Physikalisch-Technische Bundesanstalt" in Braunschweig, West Germany. The tissue dose was measured by recording the LiF-thermoluminescence of the dosimeter using the Harshaw 2000 instrument.

## 2.4 Evaluation of the mean organ dose and the total energy imparted (integral dose)

The mean organ or tissue doses and the total energy imparted (integral dose) for each of the four types of x-ray radiographs (see Table 1) were obtained from the corresponding three-dimensional dose matrix in the phantom by integration of the equation  $dE_D = \rho D dV$ , where  $dE_D$  is the energy imparted to the material in the volume element  $dV$ ,  $D$  is the absorbed dose and  $\rho$  is the density of the material in this volume element. The integral extends over the volume  $V$  of the organ, the tissue, or over the "total body", taking into account the different volumes and densities  $\rho$  of the three types of tissue equivalent material - soft tissue with  $\rho = 0.985 \text{ g cm}^{-3}$ , lung tissue with  $\rho = 0.32 \text{ g cm}^{-3}$ , and bone tissue with  $\rho = 1.45 \text{ g cm}^{-3}$  - and their distribution in the irradiated part of the body. For practical reason the integration was replaced by the sum over sufficient small volumes of the size of the mesh of the matrix,  $3 \text{ cm} \times 3 \text{ cm} \times 2.5 \text{ cm}$ , and the energy imparted to the material in the corresponding small volume.

## 2.5 Accuracy and precision

The relative accuracy of the absorbed dose  $D$  measured with a LiF-detector is 2.5% due to the uncertainty given in the calibration documents of the "Physikalisch-Technische Bundesanstalt" for the ionization chamber used for calibration of the LiF-detectors. There are variations in the sensitivity in repeated usages of the LiF-detectors and the dependence of their sensitivity on photon energy and beam direction and due to errors in calibration and reading. The precision of our repeated dose measurements in terms of the relative standard deviation was 7%. The error of the measurement of the distance between focus and patient is negligibly. The reproducibility of the tube output due to errors in high voltage, current and time of the x-ray generator was 10%.

The relative accuracy of the evaluation of the mean organ or tissue doses and of the total energy imparted  $E_D$  due to the replacement of the integral of  $dE_D = \rho D dV$  over a specified volume by a sum over volumes of about  $3 \text{ cm} \times 3 \text{ cm} \times 2.5 \text{ cm}$  and due to the irregular boundaries of the lung tissue and bone tissue in the exposed part of the phantom was estimated to be 3.5%.

The relative overall accuracy as well as the overall precision in terms of relative standard deviation was about 13%.

## 3. RESULTS

Table 1 gives energy imparted to the total body  $E_D$  in mJ for the different projections together with the condition of the exposure specified in the first column.

In Table 2 the energy imparted to the total body  $E_D$  for the radiographic examination of the chest for two beam qualities are given and compared with data obtained from the literature after "normalization" these literature data to the conditions given in Table 1. Beside the total energy imparted Table 2 gives data for the energy imparted to the thyroid as well as the mean dose  $\bar{D}$  in the thyroid. The agreement between the data from the literature obtained by Monte Carlo calculation and our data obtained by measurement are good in case of the energy imparted to the total body. They differ more in case of the dose (and energy) in the thyroid because of the location of this small organ near the field edge and the corresponding known strong variation of the dose with small variations of the distance of the thyroid to the field edge (6). Considering this effect the agreement between the data for

the thyroid is good.

Table 1

	SSD cm	mAs Product	Field Size <sup>c</sup> cm x cm	Entrance Exposure <sup>d</sup> mR	E <sub>D</sub> <sup>e</sup> mJ
Skull LAT <sup>a</sup>	100	50	24 x 30	260	3.5
Skull PA <sup>a</sup>	95	50	24 x 30	280	2.1
Chest PA <sup>a</sup>	95	30	35 x 35	175	16
Chest PA <sup>c</sup>	120	8	35 x 35	40	

a: 75 kV, 2 mm Al, HVL 2.3 mm Al, no Grid

b: 120 kV, 4 mm Al, HVL 5.5 mm Al, W S/50 Grid

c: at the film

d: free in air

e: preliminary values

Table 2

HVL mm Al	Body or Organ	Energy Imparted		
		Lit. 4 <sup>b</sup>	Lit. 5 <sup>b</sup>	Ours Measurements
2.3	Total Body	13.7 mJ	-	16 mJ
	Thyroid	0.30 μJ	0.63 μJ	1.0 μJ
		( $\bar{D}^a = 15 \mu\text{J/kg}$ )	(32 μJ/kg)	( $\bar{D} = 50 \mu\text{J/kg}$ )
5.5	Total Body	5.0 mJ	-	6.0 mJ
	Thyroid	0.29 μJ	0.80 μJ	0.32 μJ
		(14 μJ/kg)	(39 μJ/kg)	( $\bar{D} = 16 \mu\text{J/kg}$ )

a:  $\bar{D}$  mean organ dose, 1 μJ/kg = 0.1 mrd,

b: extrapolated from lit.4 and 5

The investigation is supported by a grant from the European Commission for the project: Organ and tissue doses in diagnostic radiology, a contribution to the somatic radiation exposure of the population of the Federal Republic of Germany.

#### REFERENCES

- (1) Population Exposure to X-rays, U.S., 1970.  
U.S.Department of Health, Education, and Welfare, HEW Publication  
(FDA) 73-8047 (1973)
- (2) Porretti, G.G., F.Ionesco-Parca und W.Lanz:  
Erhebung über die Strahlenbelastung der Schweizer Bevölkerung infolge  
röntgendiagnostischer Untersuchungen (1971).  
Radium-Institut der Universität Bern, Schweiz
- (3) Pauly, R., Th.Schmidt, and G.Easl:  
in press
- (4) Kramer, R. und C.Drexler:  
Zum Verhältnis von Oberflächen- und Körperdosis in der Röntgen-  
diagnostik.  
Vortrag auf der 7.wissenschaftlichen Tagung der Deutschen Gesell-  
schaft für Medizinische Physik, Heidelberg 1976. Medizinische Physik,  
Bd.2, Heidelberg: Dr.A.Hüttig Verlag
- (5) Organ Doses in Diagnostic Radiology. U.S.Department of Health, Edu-  
cation, and Welfare, HEW Publication (FDA) 76-8030 (1976)

ABSORBED DOSE TO THE PATIENT BY COMPUTERIZED WHOLE BODY X-RAY  
TOMOGRAPHY

O.Krauss and H.Schuhmacher  
Deutsches Krebsforschungszentrum Heidelberg  
Institut für Nuklearmedizin  
(Direktor: Prof.Dr.K.E.Scheer)  
Abteilung Strahlenschutz und Dosimetrie

## 1. INTRODUCTION

Patient absorbed doses by computerized X-ray tomography (CT) of the skull using an EMI-Scanner have been published by Perry and Bridges, Linke et al., and Nemeec and Roth (1,2,3). We have determined absorbed dose values from a Delta-Scanner by thermoluminescence dosimetry (TLD) in an Alderson phantom over a period of several months. In addition to our published results concerning single scan investigations of brain, lung, liver and kidneys (4), we now present dose distributions arising from multiple scan investigations of the brain and the abdomen. The standard deviation of the dose values given is less than 10%.

Every scan consists of two body cross sections each 13 mm thick. During a standard investigation the distance between consecutive scans is adjusted to 26 mm. The X-rays are generated at a fixed potential of 120 kV and an anode current of 30 mA. Filtration by the tube housing is consistent with a 3 mm Al layer. An additional 3 mm Al filter can be applied. The exposure in the central axis of the Delta-Scan amounted to 1620 mR/Scan without and 1240 mR/Scan with additional filtration. The following results have been normalized to these exposures.

## 2. RESULTS AND DISCUSSION

Fig.1 shows the integral dose values in the irradiated cross sections from one standard brain investigation consisting of six scans. On the right hand side the tissue dose distribution is given for the cross section containing the eyes. The maximum tissue doses arise at the back of the head, the X-ray tube moving on the lower semicircle and the phantom lying in supine position. With respect to the eyes this situation is advantageous in brain scanning in contrary to the spinal cord. The absorbed dose administered to the eyes is 0,6-0,7 rd. In the region of the thyroid gland (SD) the absorbed dose due to scattered radiation amounts to 25 mrd. In this case the tube is operated without additional filter. Therefore the entrance doses are considerably higher than in investigations of the trunk where the additional filter is used. An additional investigation using contrast media doubles all values, of course. Fig. 2 and 3 refer to the trunk. Fig. 2 gives the integral doses for the upper and the central irradiated cross sections from an investigation consisting of nine scans. The absorbed doses listed originate from scattered radiation and have been measured at the site of the eyes (A), thyroid gland (SD), ovaries (C) and testis (T) or at the central body axis. Towards

the head the dose decreases more slowly than in the opposite direction due to the lower absorption by the lung tissue. As for the integral doses in the irradiated region of the abdomen one would expect a significantly lower value for the outer cross sections compared with the central one (no.24) because in this case scattering contributes from one side only. The difference is, however, small because of the lower mass of the waist layer. The difference between the integral doses in the head and the abdominal cross sections does not correspond to the relatively big mass differences and must be explained by the stronger absorption of the less filtered X-radiation used in brain scans.

In fig.3 the isodose curves for the central abdominal cross section is shown (no.24 in fig.2). The entrance and exit doses are also given. The comparison of the entrance dose values from head and trunk investigations show a marked reduction in the case of the abdomen due to the stronger filtration used. As mentioned before, the high dose for the spinal cord is caused by the supine position of the patient and the upward direction of the X-ray beam. For this reason a ventral beam direction should be recommended. This would reduce the radiation burden for the spinal cord to about one third.

The FWHM of the beam profile varies from 3,5-4 cm (4). Therefore the dose in the overlapping regions of a standard investigation (scan distance 26 mm) is more than twice as high as the peak dose of a single scan (fig.4). At even smaller scanning steps the regions of overlap get broader. The peak values are more than three times as high as in a single scan if every dose profile overlaps with the one after the next as is the case at a step width of about 13 mm. This should be borne in mind when using a smaller step width.

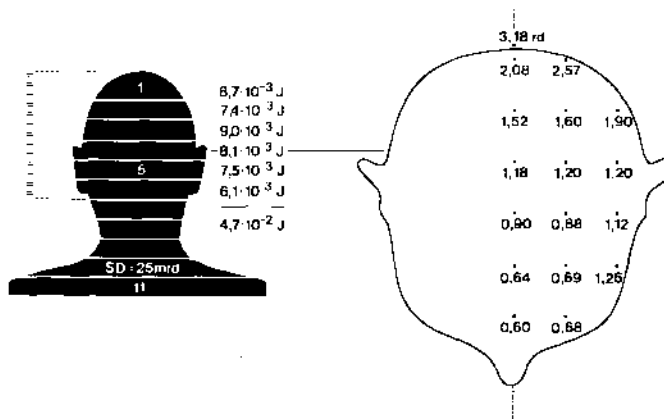

Figure 1 Integral and absorbed doses for a standard brain investigation with six scans (hatched region). Filtration: 3 mm Al. The integral doses are given in Joule ( $1 \text{ rd g} = 10^{-5} \text{ J}$ ). The tissue dose distribution for the cross section containing the eyes are given in Rad. The masses of the head sections are: 647 g (no.1), 602 g (no.5), 481 g (no.6).

Alderson Woman Phantom	Absorbed Dose(mrd)	Integral Dose(J)
A	1	
SD	3	
	14	
	27	
	64	
	158	$9,3 \times 10^{-3}$
		$10,3 \times 10^{-3}$
	132	
	43	
O	20	
T	4	

Figure 2 Integral and absorbed doses for a standard abdominal investigation with nine scans (hatched region). Filtration: 6 mm Al. The integral dose to the whole investigated region is of the order of 0,1 J (1 rd g =  $10^{-20}$ ). The masses of the abdominal phantom sections are: 1081 g (no.20), 819 g (no.24), 1382 g (no.28). For further details see text.

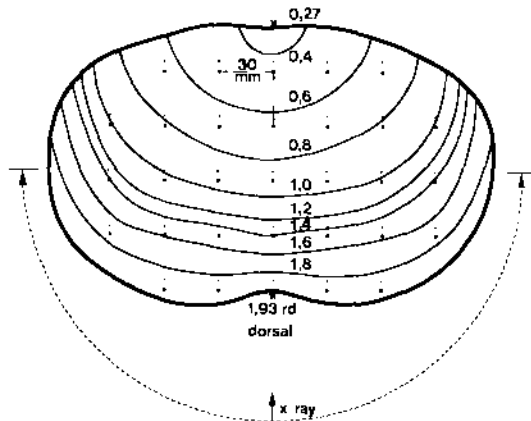

Figure 3 Isodose curves in the central region of a standard abdominal nine scan investigation (cross section no.24 in fig.2). Filtration: 6 mm Al.

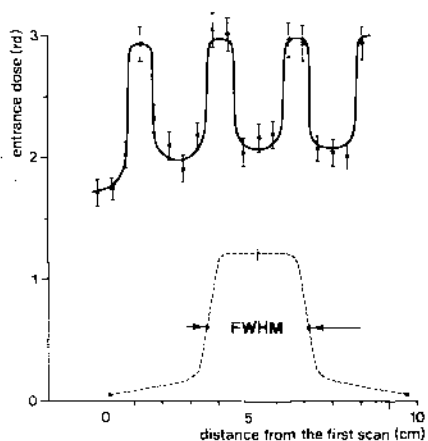

Figure 4 Entrance dose profile of a standard abdominal investigation with nine scans compared with a single scan profile. Filtration: 6 mm Al. FWHM of a single profile is 3,5-4 cm. Error bars denote one standard deviation.

### 3. CONCLUSION

The absorbed dose by a standard CT investigation is at least as high as by conventional radiography caused by the lower dose gradient in tissue and the enhancement factor described above by multiple scan investigations. For this reason future developments in CT technology should emphasize constructions reducing the dose to the patient considerably.

### REFERENCES

- (1) Perry, B.J., Bridges, C., Computerized transverse axial scanning (tomography): Part 3. Radiation dose considerations, *Brit.J.Radiol.* 46 (1973), 1048.
- (2) Linke, G., Pauli, K., Pfeiler, M., Zur Strahlenbelastung des Patienten bei der Computertomographie (Computerized axial tomography), *Electromedica* 1 (1976), 15.
- (3) Nemec, H.W., Roth, J., Untersuchungen zur Strahlenbelastung des Kopfes bei der computerisierten axialen Tomographie, "Medizinische Physik", Bd.2, p.143, (Lorenz, W.J., Ed), Hüttig, Heidelberg (1977).
- (4) Krauss, O., Schuhmacher, H., Mensch-Phantommessungen mit Thermolumineszenz-Dosimetern (TLD) zur Bestimmung der Strahlendosis des Patienten bei der Ganzkörper-Computertomographie, *Radiologe* 16 (1976), 288.

### ACKNOWLEDGEMENTS

We thank Dr.G.Wolber for useful discussions and the aid in translating the paper. The technical assistance of Mr.W.Wiesner and Mr.H.-J.Zabel is greatly acknowledged.



PATIENT DOSE IN DIAGNOSTIC X-RAY EXAMINATIONS:  
USE OF THE RANDO PHANTOM AND A DESK-TOP COMPUTER

Stewart C. Bushong, Benjamin R. Archer and Sharon A. Glaze  
Baylor College of Medicine  
Houston, Texas  
U.S.A.

## 1. INTRODUCTION

Patient dose during diagnostic x-ray examination is receiving ever more attention from radiation scientist. Methods of estimating patient dose are becoming more sophisticated and analyses of possible radiation responses are becoming more precise. This paper reports several techniques developed to measure patient dose during x-ray examination and the results of application of these techniques to representative examinations.

## 2. THE RANDO PHANTOM

The Alderson Rando Phantom (Alderson Research Laboratories, Inc.) is a standard device used for radiation therapy dosimetry studies. The phantom can be equally valuable at diagnostic energy levels if one is aware that dosimeter position within the phantom can influence the measurement of dose.

The Rando Phantom consists of a human skeleton encased in tissue equivalent Rando plastic (mass density = .985 gm/cm<sup>3</sup>,  $\bar{Z} = 7.30$ ) molded to the shape of the human body and sliced into transverse sections. A coating layer of Rando plastic is applied to each of the section faces and this coating produces discontinuities. Each phantom section is drilled with 5 mm diameter holes which are filled with "Mix D" plugs.

The Alderson Rando manual suggests placing disk type TLD's into a shallow counterbore in the section face above a shortened hole plug.

Since the coating thickness of each section face was approximately equal to the TLD thickness, a study was undertaken to determine if the suggested positioning of the TLD's would result in erroneous dose measurement.

TLD's were positioned mid-way in a phantom section surrounded by equal amounts of "Mix D" plug. An equal number of dosimeters were placed in atop a shortened plug within the coating layer of Rando plastic.

The absorption properties of the coating layer in a lung section result in as much as a 39% error in dose measurement if the dosimeter is located within the coating layer.

### 3. DESK-TOP COMPUTER PROCESSING

Computer programs were designed for analyzing data obtained using lithium fluoride dosimeters and the Rando phantom. The Wang 720 system has been used to calculate the sensitivity and maintain the exposure history of up to 1,000 dosimeters. The programs also compute the dose to each following experimental irradiation. The system consisted of a Wang 720-C desk top programmable calculator, a Wang 729 random access magnetic tape cassette memory unit and a Wang 702 IBM printer/plotter. The analysis is divided into two programs.

The first program calculates and maintains a history of the radiation response of each TLD. The second program has two segments. Part A calculates a conversion factor (nanocoulombs to millirads) from data supplied by irradiation of control dosimeters to known dose. Part B applies this conversion factor to calculate the dose received by each experimental dosimeter. Finally, the program replaces each TL reading on magnetic tape with the recorded dose. These stored values can be readily accessed for statistical evaluation or interfaced with other interpretative programs.

### 4. PATIENT DOSE

These procedures have been applied to the measurement of patient dose during various representative x-ray examinations. For each procedure, the Rando phantom was loaded with TLD dosimeters as previously described. Radiographic and fluoroscopic factors as normally employed in our hospital were set. In some instances multiple radiographic exposures were necessary in order to provide for adequate dosimeter response from dital dosimeters. The results show entrance exposures ranging from 1500 mR for a KUB exam to less than 50 mR for a PA chest. Fetal doses from near zero to 700 mrad per view were measured.

A NEW CONCEPT OF ESTIMATION OF DOSES RECEIVED  
BY PATIENTS DURING X-RAY EXAMINATIONS

Jerzy Jankowski  
Institute of Occupational Medicine  
Lodz, Poland

## 1. INTRODUCTION

The diagnostic X-ray examinations are the main source of population dose of ionizing radiation. The doses received by individual patients in the course of diagnostic investigations may vary from being about equal to the average doses received annually from natural sources to 50 times as high. The factors which influence the dose received by the body of patient during medical X-ray exposure may be divided into two general categories: anatomical and physical. The anatomical factors are mainly height and weight of patient. The physical factors are: X-ray tube current /mA/, the exposure time, the distance between the target of X-ray tube and the entrance surface of the patient, X-ray tube potential waveform, beam filtration and field size. Because of these reasons it is difficult to compare the hazard of patients even in the situation when the exposure at the body surface of patient in the direct beam and energy of radiation are identical because different per cent of volume of the body can be irradiated. Also if we use the exposure at the body surface and the surface of irradiated field /1/ the relationship between the effect and dose can not be compared because the different volume of the bone marrow could be irradiated. For these reasons it was decided to estimate the mean weighted dose at the body surface of a patient and to use this value as a parameter for comparing of the hazard from different diagnostic X-ray examinations.

## 2. METHOD

During X-ray examination the patient was dressed in a special waistcoat made from very thin foil in which the thermoluminescence dosimeters were fixed. The TL dosimeters

were located along two axis from the front and from the back of the patient making the cross and covering the whole trunk. Additional belts from foil with doseimeters were fixed to the leg and hand and also to the head. In this way about 50 doseimeters were located on the body surface. The fixing of doseimeters on the body surface was made in such a way that the characteristic points were in the same place in every case. The separate set of doseimeters was used for men and for women. Considering that the doses in the point outside the direct beam were very small the same set of doseimeters was used from a few to tens of patients for the given X-ray examination /2/. The doseimeters of the Polish production were used, made from lithium fluoride as the tablets with diameter 4,5 mm and 0,54 mm thick /3/. The dose from 1 mR up to about 1000 R could be measured. Having the dose at the body surface for every part of the body and the surface of this part of the body /Reference Man//4/ the mean weighted dose at the body surface of a patient was calculated. As the "weight" the per cent of the body surface for given part of the body was taken. The parameters of X-ray tube such as kV, mA, time exposure, filtration and FSD were noted. The weight, the height and age of patients were noted as well.

### 3. RESULTS

Using the method described above the measurements were made for the following X-ray examinations: chest fluorography /684 patients/, mass miniature radiography /600 patients/, tomography /55 patients/, urography /50 patients/, cholecystography /62 patients/, cholangiography /20 patients/, lumbo-sacral spine /130 patients/, cervical spine /198 patients/, head /211 patients/.

For every examinations the measurements were made for five X-ray tube and then the mean value for every type of examination was calculated. The table 1 gives the results for chest fluorography, urography and lumbo-sacral spine.

The table 2 gives the results for mean values for all of examinations. As it can be seen the patients received the highest doses during urography. It is also seen /table 1/ that doses depend very strongly on technical work of

physicians or technicians.

Type of X-ray tube	The mean weighted exposure on the body surface /mR/		The mean exposure /mR/			
			from entrance beam		from exit beam	
	women	men	women	men	women	men
<u>Chest fluorography</u>						
XD-12	30,0	30,0	82,0	81,0	8,6	5,2
TUR D-700	28,0	20,0	83,0	154,0	17,5	13,0
XD-12	6,0	6,2	27,0	32,0	2,0	3,2
XD-12	11,9	8,8	88,9	74,0	3,5	4,1
The mean value	16,5	16,0	66,7	80,0	5,8	5,9
The mean error	5,7	5,6	15,8	23,7	2,8	2,1
<u>Urography</u>						
XD-12	1343	1312	7850	8690	221	223
TUR D-300-1	585	984	4440	5880	67,2	84,0
Durolux	982	1420	6500	8900	109	138
XD-12	1360		8300		154	
Durolux	2130	1672	15600	12528	266	216
Philips		517		4500		98
The mean value	1335	1276	8950	8100	168	154
The mean error	242	314	2090	1170	31,7	23,8
<u>Lumbo-sacral spine</u>						
XD-12	394,0	324,0	3085	3178	34,0	68,0
XD-12	191,0	169,0	1696	1491	30,2	25,7
Multax 320	57,9	50,0	619,2	444,8	6,8	7,5
Durolux	423,2	493,0	3869	3366	42,5	26,3
TUR D-700	136,2	169,2	1117	1390	27,0	23,5
The mean value	254,9	252,9	2208	2070	32,2	31,6
The mean error	72,8	96,8	619	548	5,9	10,0

TABLE 1 The doses received by patients during some X-ray examinations

Type of examination	The mean weighted exposure on the body surface /mR/	
	women	men
Chest fluorography	16,5 ± 5,7	16,0 ± 5,6
Mass miniature radiography	103,1 ± 42,2	91,3 ± 33,0
Tomography	917,0 ± 412,0	852,0 ± 363,0
Urography	1335,0 ± 242,0	1276,0 ± 314,0
Cholecystography	376,1 ± 66,6	314,8 ± 47,2
Cholangiography	509,0 ± 63,4	459,0
Lumbo-sacral spine	294,9 ± 72,8	252,9 ± 96,8
Cervical-spine	165,1 ± 48,9	100,9 ± 19,0
Head	151,7 ± 38,3	136,8 ± 43,6

TABLE 2 The mean weighted exposure on the body surface

REFERENCES

- /1/ CAMERON, J.E., Health Physics, 21, 879, /1971/
- /2/ JANKOWSKI, J., Distribution of Dose Exposure at the Body Surface of Patients During Some X-Ray Examinations. Digest of the Fourth International Conference on Medical Physics., Ottawa, July, /1976/
- /3/ NIEWIADOMSKI, T., JASIŃSKA, M., RYBA, E. Nukleonika 11, 535, /1973/
- /4/ Report of the Task Group on Reference Man ICRP No 23, Pergamon Press, Oxford, /1975/.

THE MEAN ACTIVE BONE MARROW DOSE  
TO THE ADULT POPULATION OF THE UNITED STATES  
FROM DIAGNOSTIC RADIOLOGY\*

B. Shleien, T. T. Tucker and D. W. Johnson  
Food and Drug Administration, Bureau of Radiological Health  
Rockville, MD 20857

The use of radiation in the healing arts is recognized as the largest man-made component of radiation dose to the United States population. Several investigations have been published on the magnitude of the gonad and the genetically significant dose from medical radiation to the United States population (USPHS76). This paper summarizes information on mean active bone marrow doses to adults from diagnostic radiography, fluoroscopy and dental radiography as practiced in the U.S. in 1970. It presents an estimate of the mean per capita active bone marrow dose for the total adult population and illustrates the effect of age on per capita radiation dose. While mean active bone marrow doses for children are not estimated in this presentation due to insufficient data, an estimate is made of the effect of the lower rate of use of diagnostic x-rays (except dental) in children on the per capita dose to the entire population. Comparisons are made with the results of the 1964 U.S. x-ray survey and similar studies from other nations. A detailed description of this study has been published (Sh77).

Estimates of mean active bone marrow doses in this study are based on an empirical model and computer program previously published (E175). Briefly, the method makes use of experimental measurements of the ratio of skin exposure to bone marrow cavity exposure made under various exposure conditions with a phantom similar to "standard man;" a conversion factor from exposure to absorbed dose in a cavity containing marrow; a standardized model for the distribution of active bone marrow in an adult; and, a computer program combining the parameters above with x-ray machine technical information. The U.S. Public Health Service X-Ray Exposure Survey of 1970 (USPHS73) provides information on the rate of diagnostic medical and dental x-ray examinations, x-ray exposure, machine technical parameters, and age and anthropomorphic characteristics of patients. Similar information was gathered in 1964, but with less reliability because of a smaller sample size. In 1970, 21,500 households were sampled representing approximately 67,000 persons. Follow-up questionnaires were sent to 12,213 facilities to obtain details of machine characteristics, projection, distance, kVp, mA, exposure time, film size, collimation, grid, and screen for each film taken during an examination. Although the sample size is small (approximately 0.04 percent of diagnostic medical x-rays performed in 1970), the method of sampling is such that it is representative of the total U.S. population.

The mean active bone marrow doses for specific examinations and projections were determined on a per film and per examination basis. Only doses per film are presented here because of space limitations. These are found in Table 1, column 2. In examinations that include fluoroscopy, subtotals for the scan, spot films, and radiographic portions are indicated.

\* This paper represents the views of the authors and may not represent the official views of the Food and Drug Administration.

TABLE 1.  
MEAN ACTIVE BONE MARROW DOSE  
Per Film for Selected Examinations (1970 and 1984) Adults

Examination	View	1970		No. of examinations	1984		No. of determinations
		Mean active bone marrow dose per film (mrad) <sup>(a)</sup>	S.E. (b)		Mean active bone marrow dose per film (mrad) <sup>(a)</sup>	S.E. (b)	
Skull	AP	27	1.7	91	22	2.0	63
	PA	14	0.8	167	15	2.2	55
	Lat	17	1.0	738	16	1.5	134
Cervical Spine	AP	19	3.3	245	16	1.7	89
	Lat	9	1.9	202	5	0.6	83
	Ob*	15	3.7	142	6	1.3	43
Chest, Posteroanterior	PA	43	0.5	759	62	0.6	44
Chest, Radiographic	PA	4.5	0.7	1454	3.5	0.3	677
	Lat	17	0.4	768	5.5	0.9	266
Thoracic Spine	AP	20	14	88	91	12	29
	Lat	20	11	73	11	20	3
Ribs	AP	56	4.8	57	73	17	21
	PA	40	9.1	27	-	-	(c)
	Ob*	61	6.5	55	46	8.5	72
Upper GI Series	AP	75	4.1	776	55	4.3	115
	PA	72	2.8	338	58	3.0	222
	Lat	75	4.5	339	52	4.2	63
	Coll	60	1.9	589	44	7.1	206
	Scap	157	7.3	115	161	22	114
	Spot film AP	4.8	0.4	147	5.7	0.3	744
	Spot film PA	7.2	0.4	146	5.1	0.3	192
Lumbar Spine	AP	13	1.3	47	4.2	0.4	35
	Lat	11	0.4	385	5.7	2.3	460
	Ob*	103	6.5	183	96	17	64
Lumbar Spine	AP	51	7.6	274	62	15	77
	Lat	51	5.6	87	103	21	74
	Ob*	102	18	20	-	-	(d)
Left Shoulder	AP	120	8.0	37	63	5.3	28
	PA	54	5.7	84	58	6.6	45
Left Shoulder	PA	41	2.6	268	41	3.8	114
	Lat	35	7.7	25	18	5.6	17
	Coll	34	7.5	206	39	5.7	78
	Scap	29	12	18	34	7	4
	Spot film AP	1.2	0.1	31	7	3.5	5
	Spot film PA	1.6	0.4	10	-	-	(d)
	Spot film Ob*	3.6	2.8	17	0.3	0.9	4
Abdomen, KUB	AP	92	6.2	157	112	6.6	74
	PA	48	7.5	74	-	-	(d)
Barium-Grota	AP	123	5.1	263	97	5.0	91
	PA	115	6.9	164	91	5.9	114
	Lat	231	26	79	165	24	20
	Ob*	104	8.0	156	123	13	34
	Scap	268	45	31	279	40	28
	Spot film AP	15	1.5	42	8.4	0.9	78
	Spot film PA	27	5.6	3	14	1.6	38
Hip	AP	91	6.4	5	46	9.7	13
	Lat	28	1.5	84	8	1.8	114
	Ob*	79	1.7	758	74	2.6	331
Lumbosacral Spine	AP	79	4.2	115	70	11	18
	Lat	97	8.0	116	92	11	43
	Ob*	181	13.0	131	167	17	51
Pelvimetry	AP	83	8.1	51	84	5.3	77
	AP	170	23	24	-	-	(d)
	Lat	333	51	9	-	-	(d)
Pelvis	AP	69	4.1	53	75	5.0	52
	AP	79	2.4	55	35	3.4	42
	Lat	44	4.0	46	46	5.5	23
Femur	AP	14	4.3	19	-	-	(d)
	Lat	7.0	1.7	11	-	-	(d)
Dental	Anterior teeth	2.9	0.1	243	3.4	0.1	133
	Posterior teeth	0.5	0.1	4897	1.1	<0.1	2576

(a) Based on calculated skin exposures with Patient No. 16 in x-ray beam. Thus, the resultant dose includes backscatter and assumes all patients approximately "standard man."

(b) Standard error of the Mean (S.E.) equals  $\frac{\text{Standard Deviation}}{\sqrt{n}}$ .

(c) Based on laboratory determination of exposure with several representative types of RBG equipment weighted by estimated use of type.

(d) Not determined - less than ten sample films.



The estimated adult annual per capita mean active bone marrow dose to the U.S. population in 1970 was 103 mrad. Interestingly, examinations having the highest examination rates for adults (radiographic Chests and Dental examinations) contribute only about 3 percent each to the total annual adult per capita mean active bone marrow dose because of their relatively low doses per individual examination. The highest annual per capita doses are due to Upper G I Series and Barium Enemas. Although the annual per capita dose is the same, it results from different reasons; an Upper G I Series having approximately twice the examination rate, but a little over half the mean active bone marrow dose per examination. Other examinations, besides Upper G I Series and Barium Enema, making significant contributions to the dose are IVP, Lumbar Spine, and Lumbosacral Spine. These five examinations account for almost 68 percent of the total annual adult per capita dose.

If the contribution of examinations from specific body areas is considered, examinations of the head and neck (including dental examinations) contribute 6 percent of the total annual adult per capita dose; examinations of the thorax 12 percent; examinations of the upper and lower abdomen about 39 percent each; and examinations of the pelvic area 4 percent. From the point of view of examination type, radiographic procedures contribute 79.8 mrad to the annual per capita mean active bone marrow dose (or 77 percent); fluoroscopic scans and spot films account for 20.3 mrad (or 20 percent) and dental examinations 2.9 mrad (or 3 percent).

The annual per capita mean active bone marrow dose to adults in 1964 is estimated to have been 83 mrad. Thus, an increase (statistically significant at 1.64 S.E.) of 23 percent in the annual per capita dose occurred between 1964 and 1970. This increase is, for the most part, due to an increase in doses associated with radiographic procedures of the abdominal region. In turn the increase in dose per examination is attributable to an increased exposure per film (Sh77), the mean number of films per examination having remained relatively constant during the two periods. It has been hypothesized (Sh77) that the increased dose per film in 1964 relative to 1970 is due to increased use of grids and/or increased use of grids having a higher grid ratio.

Assuming that the mean active bone marrow dose does not vary for a particular x-ray examination above the age of 15, one can use the product of the age specific examination rate and mean active bone marrow dose per examination to obtain an estimate of the per capita mean active bone marrow dose associated with an age group. This varied from an annual per capita mean active bone marrow dose of 55 to 151 mrad for the 15-24 year old and 65 + age groups respectively.

Changes in x-ray examination rate with age modified by the relative magnitude of the dose both influence the contribution of specific examinations to the age-specific dose. In the younger age groups, 15-24 and 25-34 years of age, Lumbar and Lumbosacral Spine examinations contribute the most to the per capita mean active bone marrow dose. Upper G I Series and Barium Enema are highest contributors beginning in age group 35-44 and continuing thereafter.

Although mean active bone marrow doses are not available for the population group below age 15, there are some salient facts relevant to this group that are pertinent to understanding radiological practices in the U.S. This age group represents 29 percent of the total population, experiences 25 percent

of all dental examinations performed, 5 percent of all radiographic examinations (excluding examinations of the extremities), and 2 percent of all fluoroscopic procedures. The lower rates of radiographic and fluoroscopic examinations in this age group would reduce the annual per capita mean active bone marrow dose to the entire U.S. population by at least 25 percent (to approximately 77 mrad) of that estimated exclusively for the adult U.S. population, assuming that the mean dose per examination was the same in all age groups. One would expect that skin exposures for this age group are somewhat lower and indeed this is the case (Sh77). However, the effect of a different distribution of active bone marrow in children, with significant quantities of this substance in the extremities, and different ratios of skin to bone marrow site exposure for children make it impossible at present to verify the above estimate.

Population mean active bone marrow doses from diagnostic radiology to national population groups in terms of the annual per capita dose, range from 30 mrad (Netherlands 1964) to 189 mrad (Japan 1969) (Sh77). The mean annual per capita dose of 103 mrad to the adult population of the U.S. is numerically similar to the annual per capita radiation doses to the whole body (130 mrads) and bone marrow (86 mrads) from natural radiation.

#### References

- El75 Ellis, R. E., Healy, M. J. R., Shleien, B. and Tucker, T. T., 1975, "A System for Estimation of Mean Active Bone Marrow Dose," Food and Drug Administration, Bureau of Radiological Health, HEW Publication (FDA) 76-8015.
- Sh77 Shleien, B., Tucker, T. T. and Johnson, O. W., 1976, "The Mean Active Bone Marrow Dose to the Adult Population of the United States," Food and Drug Administration, Bureau of Radiological Health, HEW Publication (FDA) 76-8013.
- USPHS73 U.S. Public Health Service, 1973, "Population Exposure to X-Rays, U.S. 1970," Food and Drug Administration, HEW Publication (FDA) 73-8047.
- USPHS76 U.S. Public Health Service, 1976, "Gonad Doses and Genetically Significant Dose from Diagnostic Radiology, U.S. 1964 and 1970," Food and Drug Administration, HEW Publication (FDA) 76-8034.

A NEW METHOD TO ASSESS THE GONADAL DOSES  
IN WOMEN DURING RADIATION TREATMENT

M.S. AGRAWAL and G.C. PANT

Centre of Radiotherapy and Radiation Medicine  
Institute of Medical Sciences, Banaras Hindu  
University, Varanasi - 221 005, I n d i a

1. INTRODUCTION

In recent times, the survival rates of cancer patients have improved considerably reflecting the increasing public awareness, better radiotherapeutic techniques and the multidisciplinary therapeutic approach. Moreover, a sizeable portion of this populace is in the child bearing age group and consequently, the gonadal doses received by these patients need special attention. Male gonadal shields have been described by Jackson et al. (1) and Gleen and Johnson (2) in an attempt to reduce the radiation doses. Almond et al. (3) and Villafana (4) have attempted to assess the foetal doses. The relative inaccessibility of the ovaries renders direct measurement of gonadal dose difficult. Novotny and Tarakanath (5) have described a method to assess the ovary dose as the percentage of the tumour dose. In the present study, a relatively simple method is described to assess the ovary dose during radiotherapy.

2. MATERIALS AND METHODS

The upper margin of the pubic symphysis is taken as the reference point for measurements. The measurements were done on a human mannequin phantom with Li<sub>2</sub>B<sub>4</sub>O<sub>7</sub>.Mn (6) and a TLD Reader described by Gangadharan et al. (7) on an Eldorado-6 Cobalt-60 teletherapy unit.

The dosimeters (gelatine capsules containing Li<sub>2</sub>B<sub>4</sub>O<sub>7</sub>.Mn powder) were kept at the two ovary positions and the reference point in the phantom. The phantom was put in the treatment position and given an exposure by a fixed field size. The distance 'd' between the lower edge of the field and the reference point was kept constant. The dose recorded by the dosimeters at the reference point and the gonads were measured. For a fixed field size, the doses at the reference point and ovaries were measured for varying values of 'd'. Similarly, the experiment was repeated for various values of 'd' varying the field sizes and the doses at the ovaries and the reference point were measured.

For a fixed field size, the ratio of the mean dose recorded by the gonads and the reference point was found out for various values of 'd' and is plotted as a function of 'd' in Figure 1.

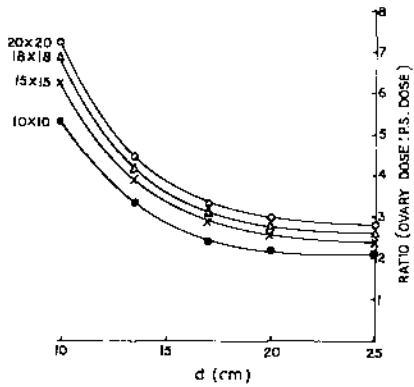

Fig.1 - The ratio of the mean dose recorded by the gonads and the reference point as a function of 'd' for various field sizes.

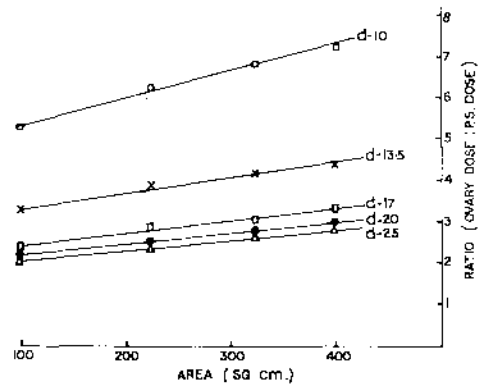

Fig.2 - The ratio of the mean dose recorded by the gonads and the reference point as a function of area for various values of 'd'.

Similarly, for a fixed value of 'd', the ratio of the mean dose of gonads to the reference point is also plotted as function of area in figure 2.

For posterior field treatment, a point opposite to pubic symphysis is marked on the posterior skin and this serves as the reference point. Figures 1 and 2 stand true for the posterior field treatment also.

### 3. RESULTS

Figure 1 relates the observed ratios of the radiation doses at the ovary and the reference point to 'd' for various port sizes. Similarly, Figure 2 gives the relationship between the area of the port and the dose ratio of ovary to the reference point for various values of 'd'. With the help of the figures 1 and 2, the ratio of the doses at ovary and the reference point can be found out - for the treatment conditions. Once this ratio is known, the ovary dose can be assessed easily by measuring the doses at the reference point in actual treatment conditions.

### 4. CONCLUSION

A simple method for assessment of ovary doses during radiotherapy is described. The ovary doses can be assessed by simply measuring the dose at pubic symphysis during radiotherapy.

### REFERENCES

1. Jackson, H.L. et al., Radiology, 96 (1970), 181
2. Gleen, D.W. and Johnson, R.E., Radiology, 104 (1972), 214
3. Almond, P.R. et al., Am. J. Roent., 108 (1970), 197
4. Villafana, T., Health Physics Society, VII Mid Year Topical Symposium (1973)
5. Novotny, J. and Tarakanath, M.S., Strahlentherapie, 152 (1976), 191
6. Murthy, B.K.S. et al., Proc. TLD Seminar, Bombay (1970)
7. Gangadharan, P. et al., Proc. IAEA/WHO Symp. Rad. Prot. Monitoring, Bombay (1968), 307.

NEW RESULTS REGARDING GONADAL EXPOSURE  
IN UROLOGIC X-RAY DIAGNOSTICS

R. Barke

Radiological Clinic of the Medical Academy  
"Carl Gustav Carus", 8019 Dresden / GDR

1. INTRODUCTION

The importance of Radiodiagnosis as a dominant factor for the exposure to ionizing radiation is generally accepted. The estimation of the genetic significant dose of the population produced by Roentgenology is of great interest and means a request of WHO.

The base for any statistical review is in every case the measuring of the individual gonadal exposure in patients undergoing an examination in the X-ray department.

2. IMPORTANCE OF I.V.UROGRAPHY

In the different types of X-ray examination it is only a small number, which causes the main part of genetic dose. I.v. urography belongs to those procedures of essential importance for gonadal exposure. It is the most practised examination in urologic X-ray diagnosis, and SAELLENTAG (1) regards it to be the procedure with the highest gonadal exposure in conventional diagnostic.

In statistical reviews from different countries we find that the share of i.v. urography in the genetic significant dose produced by Radiology is of varying percentage (2):

Great Britain	12 %
USA	13 %
Sweden	15 %
GFR	8 %

In i.v. urography the gonadal exposure of men may be defined relatively exact, where as the exposure of the ovaries must be estimated from indirect measuring. A reliable reference method is not yet available. The factor for reducing the exposure dose of the testicles when using lead protectors is about 30 : 1. Previous statistical reviews are not suitable to be the base for a comprehensive estimation of the GSD produced by Radiodiagnosis.

It is necessary to gain new results of measuring for all those examinations for which a high genetic radiation exposure must be expected.

Own experiences with condensor chambers and TLD let us prefer the latter for further investigations.

#### REFERENCES

- (1) SEELENTAG, W.: Zur Frage der genetischen Belastung der Bevölkerung durch die Anwendung ionisierender Strahlen in der Medizin - Teil II  
Strahlentherapie 105 (1958) 169 - 195
- (2) GURSKY, S.: Ermittlung der Strahlenbelastung in der Röntgendiagnostik  
Rad.diagn. 15 (1974) 405 - 426
- (3) EWEN, K. - SCHMITT, G. - KAUFMANN, H.: Gonadenexpositionen bei drei röntgendiagnostischen Standarduntersuchungen  
Fortschr.Röntgenstr. 116 (1972) 803 - 817
- (4) MOHR, H.: Über Messungen der Gonadendosis bei Patienten in der Röntgendiagnostik  
Strahlentherapie 106 (1958) 80 - 84

iciency of some modifying factors (used filmsizes resp. field sizes, distance of field border to the testicles, influence of radiation energy which must be varied according to body weight - tables in poster session -).

#### 4. RESULTS

In 65 men, using X-ray protectors (2 mm resp. 1 mm lead) for the testicles the gonadal dose amounted to 23 mR on an average for the complete urography.

The doses for a single exposure were

- 0,4 mR per minimum for the small sized exposition of the kidneys (great distance of X-ray beam to the testicles)
- about 4,5 mR for exposures of the uropoetic system in large format
- about 10 mR for a radiograph of the urinary bladder.

In urographies under the same standard conditions but without any protectors for the testicles the gonadal dose increased up to more than 850 mR.

In female patients the ovarian dose amounted to 1 500 mR on an average. As it is impossible to carry out direct measuring in patients the use of tables (determined for Radiotherapy) and mathematic operations are necessary. Thus we obtain results within a wide range (800 - 2 400 mR!).

#### 5. SUMMARY AND CONCLUSION

Exact measuring of gonadal dose is the base for determination of the GSD produced by X-ray diagnosis.



In previous communications the values for gonadal exposure in i.v. urography differ within wide ranges. We find results of measuring from 14 mR (3) up to 1 000 mR (ZUPPINGER 1961) or even 2 630 mR (4).

### 3. MATERIAL, METHODS

To define the GSD of our own population it was necessary to gain actual results of measuring the gonadal exposure. Reasons therefore were additionally:

- Methods of X-ray examination for urology changed (more contrast medium, more exposures pro patients, better X-ray protection).
- Progress in radiological technic, especially referring to the sensibility of the imaging systems resulted in better conditions for a lower dose exposure.

In 130 patients undergoing i.v. urography the X-ray dose for the gonads was evaluated by means of condensor chambers (PTB Condiometer) and in several cases by TLD. Male patients were examined using a special X-ray protector (2 mm lead) for testicles and a 45 mm condensor chamber. Only in a few cases the gonadal dose without X-ray protector was determined. In female patients the exposure dose of the ovaries was estimated from measuring the surface dose, and in some cases by intravaginal application of TLD detectors.

I.v. Urography in all cases was performed under standard conditions recommended by the Radiological Society of the GDR. The efficient dose was - if possible - measured for each single exposure within one examination. Thus it was possible to define the ef-

## RADIOPROTECTION OF PATIENTS IN RADIOTHERAPY: THE GONADAL DOSES RESULTING FROM TREATMENTS AT ELECTRON ACCELERATORS.

F.Nuesslin and E.Hassenstein  
 Medizinische Hochschule Hannover, Abteilung Strahlentherapie,  
 Karl-Wiechert-Allee 9, D-3000 Hannover.

### 1. INTRODUCTION

Since the time electron accelerators have been used in radiotherapy for several kinds of malignant diseases the survival rates were enhanced significantly. Therefore, it is necessary to draw even more attention on the radioprotection of the patient, particularly, when children or young patients are treated.

The dose absorbed by the patient in regions outside the primary beam may be separated in three components, the leakage radiation of the accelerator, the stray radiation from the treatment room and the scatter in the patient. All parts interfere in a complicated manner. So, it is necessary to study the influence of some factors on the dose distribution in the whole body of the patient. In this paper results will be presented when varying the following parameters: the beam quality, the beam energy, the protection effect of lead shielding, the spatial orientation of the phantom and the field size. Due to the fact that betatrons and linear accelerators are the machines most frequently used in radiotherapy centers today, the secondary radiation field of either accelerator type was investigated.

### 2. METHOD AND RESULTS

In a systematic study dose profiles were measured in a phantom of polystyrene (75x25x20 cm) using LiF-dosimeters. The maximum lateral distance to the beam axis was 50 cm, the distance between the measuring points was 6 cm. The phantom was fixed on the treatment couch and it was irradiated with the gantry being in vertical position. Experimental details are given elsewhere (1).

#### 2.1 Measurements at the betatron

The phantom was irradiated at a 45 MeV betatron (Siemens) with 45 MV X-rays, 10 MeV, 18 MeV and 45 MeV electrons. Adequate compensating filters and scattering foils were used for beam flattening. The X-ray field size was 10x10 cm at 100 cm SSD, the electron field was defined by a cone of 12 cm diameter at 120 SSD. The results are summarized in table 1.

#### Beam quality and energy

Due to the small side scattering of high energy photons  $D^e(x)$

falls more rapid with the lateral distance  $x$  than in the case of the electron beam of the same energy: at 45 MeV the ratio of the slopes  $d\log D/dx$  is about 3. However, with respect to the maximum dose in the beam center axis the dose at the X-ray field edge is 20 times as high as for the electron beam. At large lateral distances this difference is smoothed. Comparing the dose distributions at different electron energies the slopes of the profiles do not change, whereas the relative dose decreases with primary beam energy.

energy	lead (mm)	$D_{10}^e$ (%)	$D_{40}^e$ (%)	$D_C^c$ (%)	$D_{40}^c$ (%)	$d\log D/dx$
45 MV X	0	28	1	63	0.65	0.046
45 MV X	1	16	0.35	80	0.28	0.055
45 MeV $e^-$	0	46	13	2.6	0.32	0.017
45 MeV $e^-$	1	28	5.7	3.7	0.22	0.020
18 MeV $e^-$	0	27	8.7	1.2	0.12	0.017
18 MeV $e^-$	1	20	4.5	1.2	0.05	0.022
10 MeV $e^-$	0	12	3.1	0.73	0.02	0.022
10 MeV $e^-$	1	5.4	0.5	0.73	0.007	0.034

Tab.1: Dose profiles at the betatron.  $D_x^e$  =relative dose normalized at the field edge;  $D_x^c$  =relative dose normalized at the beam center line;  $x$  : lateral distance to the field edge.

#### Protection effect of lead shielding

Dose distributions were measured with the phantom covered with lead sheets of 1 to 3 mm thickness against stray and leakage radiation outside the primary beam. The penetrating power of the radiation measured by means of the HVL in lead was found to decrease by a factor up to 0.3 over the whole lateral distance. The efficacy of the lead shielding depends on the distance from the field edge, mainly. At high energies the build-up is shifted from the phantom into the lead cover causing a rise in dose near the field edge. At greater distances, however, a dose reduction by an amount up to 0.35 was found by covering with 1 mm Pb, only. Because with greater depths in the phantom corresponding to the localization of the female gonads the phantom scatter becomes dominant, protection with lead is more effective in the treatment of male patients.

#### Spatial orientation of the phantom

The dose in the phantom measured at greater distances to the beam center line varies significantly with the orientation of the treatment couch. As expected from the technique of beam generation in this betatron dose minima were observed in the plane normal to the electron orbit. The maximum values in the electron and in the photon mode were measured in the plane of the electron orbit at opposite directions. By positioning the patient properly it is possible to reduce the gonadal dose to 1/2 of the value obtained at the  $0^\circ$ - and  $180^\circ$ - direction, respectively.

## Field size

A variation of the field size modifies the dose profiles significantly in the electron mode, only. The influence of the field size becomes important with decreasing electron energy and increasing lateral distance.

## 2.2 Measurements at the linear accelerator

A second series of dose profiles were measured at the Clinac-18 (Varian) using flattened beams of 10 MV X-rays, 6 MeV and 18 MeV electrons. The field size was  $10 \times 10 \text{ cm}^2$  at 100 cm SSD. In the electron mode a cone was used. Some results are given in table 2.

energy	lead (mm)	$D_{10}^e$ (%)	$D_{40}^e$ (%)	$D_0^c$ (%)	$D_{40}^c$ (%)	$d \log D / dx$
10 MV X	0	29	3.0	25	0.75	0.046
10 MV X	1	10	0.55	39	0.22	0.042
18 MeV $e^-$	0	12	0.8	12	0.12	0.038
18 MeV $e^-$	1	9.5	0.75	6.5	0.05	0.038
6 MeV $e^-$	0	1.2	0.13	22.5	0.03	0.032

Tab.2: Dose profiles at the linac. Same symbols as in tab.1.

## Beam quality and energy

Comparing the photon beams of both accelerators the dose profiles of the linac are less steep, but with respect to the center axis maximum dose the dose at the field edge is more favourable. This is a consequence of the quite different beam energies, mainly. Contrarily, the profiles at 18 MeV electron energy show an inverse behaviour. Compared to the betatron the dose at the field edge is now about 10 times higher. This may be caused by the different construction of the electron cones used at either accelerator.

## Protection effect of lead shielding

In the photon mode the HVL of the leakage and stray radiation spectrum decreases with the distance to the field edge by more than  $1/4$ , whereas at electron radiation the HVL varies over the same distance by  $1/2$ , only. The dose sparing effect of 1 mm lead covering the phantom amounts up to about  $1/3$ .

## Spatial orientation of the phantom

Because the electrons in the Clinac-18 are deflected by a  $270^\circ$ -magnet before hitting the bremsstrahl target the leakage radiation in the photon mode has maxima both in the  $0^\circ$ - and in the  $180^\circ$ -direction of the treatment couch. The difference in the dose at large distances to the primary beam with the couch being parallel or normal to the tube axis, respectively, amounts to about a factor 2. In the electron mode,

particularly, at 6 MeV incident energy, in the 180 direction the dose profile decreases surprisingly slow, probably indicating an additional leakage radiation component from the clystron.

### 3. DETERMINATION OF THE GONADAL DOSES

One of the aims of these measurements was to estimate the gonadal load of a patient treated at either accelerator type. Therefore, the dose absorbed by the gonads during treatment was measured using the man-like Alderson-Rando phantom.

region	energy	$D_{\text{f}} (\%)$	$D_{\text{m}} (\%)$	$D_{\text{f}} (\text{mGy})$	$D_{\text{m}} (\text{mGy})$
mediastinum	45 MV X	1.5	2.0	68	90
	10 MV X	2.0	2.4	90	110
	45 MeV e <sup>-</sup>	3.0	2.0	135	90
	18 MeV e <sup>-</sup>	0.5	0.9	23	41
paraaortal lymph	45 MV X	4.0	1.0	180	45
	10 MV X	6.0	4.0	270	180
nodes	45 MeV e <sup>-</sup>	1.5	0.7	68	32
	18 MeV e <sup>-</sup>	0.3	0.2	14	9

Tab.3: The gonadal load resulting from treatments at accelerators. Relative doses are normalized against the maximum dose. Last two columns: Gonadal load resulting irradiation with 45 Gy maximum dose for female (f) and male (m) patients, respectively.

Table 3 shows the gonadal load measured at two different field localizations. The figures given in the last two columns are doses absorbed by the gonads during a radiation treatment with 45 Gy maximum dose. Comparing these data to the values estimated on the basis of the dose distribution measurements no remarkable discrepancies were found.

#### REFERENCE

- (1) NUSSLIN, F., HASSENSTEIN, E. 'Die Gonadenbelastung bei der Strahlentherapie gutartiger Erkrankungen', Strahlentherapie 151 5 (1976) 409

## RADIATION PROTECTION OF THE HUMAN EMBRYO IN X-RAY EXAMINATIONS

W. Herstel

Institute of Radiopathology and Radiation Protection  
 Department of Radiology, University Hospital Leiden - Holland

## 1. INTRODUCTION

Shortly after the discovery of X-rays, in November 1895, it became known that this radiation provokes biological effects. These effects have been and are still the subject of extensive studies (1,2,3). An important question which remains to be answered is whether the results obtained from animal experiments can be applied to irradiation of human beings. Up to now, however, more is known about the results of exposures to high radiation doses than to low radiation levels such as normally occur in the diagnostic use of X-rays. During examinations of the abdominal area the dose at the embryo can be of the order of 0.5 to 10 rad. This is rather low compared with radiotherapy. For the sake of radiotherapy the radiation dosimetry has been centered to the individual patient, whereas the physics of radiodiagnostics was directed towards general trends such as the improvement of image systems and the protection of the patient. Generally pregnant women should not be exposed to X-radiation, but sometimes this is unavoidable due to the patient's condition. Sometimes a woman is unaware that she is pregnant. In all these cases the dose delivered to the embryo or the foetus should be as small as possible.

## 2. METHOD

The radiation dose received by the embryo or the foetus was determined under realistic circumstances. The incident radiation was measured during a large number of clinical examinations using a flat ionisation chamber in front of the X-ray source. This flat ionisation chamber was coupled to a diagnostic dosimeter ('Diamentor') which actually measures the surface integral of the radiation exposure. The results of these measurements is expressed as the product of exposure and surface, thus in  $Rxcm^2$ . During the examinations the fluoroscopic image was recorded on videotape thus enabling us to reproduce the situation when afterwards the same irradiations are repeated on a human body phantom. The body phantom, which was used for the estimation of the embryonic dose, was built from a statistical study undertaken for the clothing industry. It has the shape of the human body, and it has transparent plastic walls (4 mm thick) and it contains a complete skeleton. In the pulmonary region the lungs are simulated by fillings consisting of a mixture of sawdust and polystyrene grains. The other body tissues are simulated by water. The first specimen was constructed by Beekman and Weber (4). For the measurements in the uterine region a 3.5 cc. ionisation chamber was used connected with a Pitman dosimeter. The abdomen of the phantom used for the estimation of the embryonic radiation dose is 23 cm thick. A much thicker phantom (28 cm masonite) is used for estimating the foetal dose during intrauterine transfusion, which are normally carried out after the 28th week of pregnancy.

## 3. RESULTS

The results of these measurements are given in fig. 1 and 2 and in table 1. Fig. 1 illustrates the distribution of the exposure-surface product (XSP) of two types of examinations. Table 1 gives the XSP and the embryonic dose (ED) for a group of examinations. Fig. 2 shows the gradual reduction of the foetal dose during intrauterine transfusions in eight successive years (period 1966-1974). There were at least ten transfusions per year.

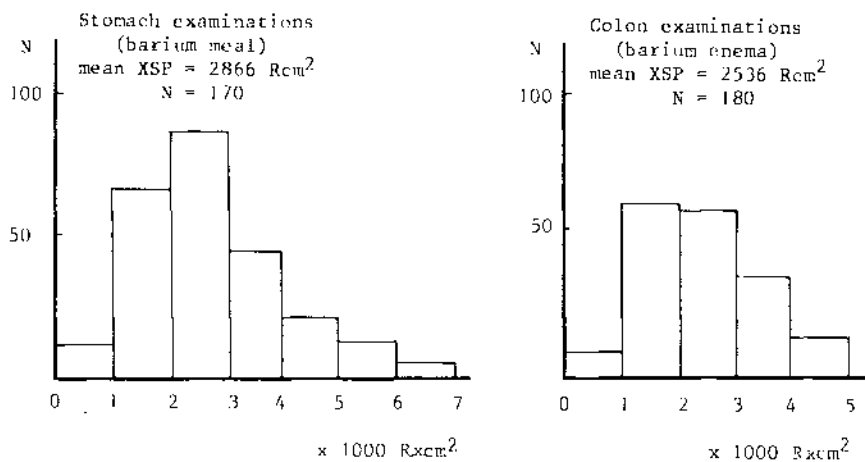

FIG. 1. Histograms showing results of two types of examinations  
XSP = exposure-surface product

examination	XSP(Rcm <sup>2</sup> )	ED(mrad)	examination	XSP(Rcm <sup>2</sup> )	ED(mrad)
thorax	33	1	intravenous	2881	848
galbladder	536	7	pyelography		
stomach	2866	57	salpingography	330	720
colon	2536	1443	lumbar spine	1306	1163

TABLE 1. Exposure-surface product (XSP) and embryonic dose (ED) for various clinical examinations

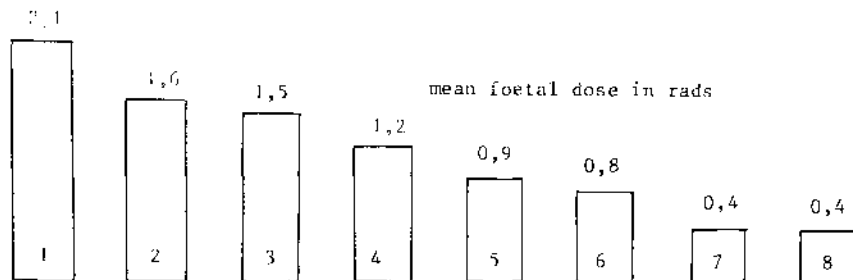

FIG. 2. Gradual reduction of foetal dose during intrauterine transfusions during eight successive years

#### 4. COMMENTS AND RECOMMENDATION

When no phantom measurements can be carried out, approximate values of the embryonic dose (mrad) can be found in table 2 which is standardized for an exposure at the skin of 1 R, square fields FSD = 100 cm and irradiation from behind (PA-direction).

region		thorax	waist	abdomen	femur
field (cm <sup>2</sup> )		20 x 20	20 x 20	20 x 20	10 x 10
kV	mm Al				
75	2.6	2.8	9.6	41.7	26.3
85	2.9	4.6	14.6	81.5	31.6
95	3.4	5.6	24.8	108.1	42.1

TABLE 2. Estimation of the embryonic dose

When the X-ray source is in front of the patient, the embryonic dose will be 10 to 20 times higher. The X-ray tube should be mounted beneath the examination couch. Female patients in the child bearing age should be examined in the first week of the menstrual cycle. (5,6)

#### 5. REFERENCES

1. RUSSEL L.B., W.L. RUSSEL, Radiation hazards to the embryo and foetus, Radiology 58, (1952) 369
2. RUGH R., X-ray induced teratogenesis in the mouse and its possible significance to man, Radiology 99, (1971) 433
3. LAWS J.W., Implementation of "The 10 day rule", Clin.Rad.27 (1976)42
4. BEEKMAN Z.M., Genetically significant dose from diagnostic roentgenology, Thesis Leiden 1962
5. HERSTEL W., L'influence de la position du tube de rayons X sur la dose-gonades et le rayonnement diffusé, Annales de Radiologie 8,65,7
6. HERSTEL W., Diagnostic X-ray Exposure and the Human Embryo, University of Leiden (1974)
7. BRUWER A., If you are pregnant, or if you think you might be..., Editorial, American Journ.Roentgenology (1976) 696

#### 6. WARNING AT X-RAY DEPARTMENTS

One of the ways to protect the fetus is to draw the attention of female patients entering the department (7). We use the warning shown below.



#### IMPORTANT

if you are pregnant ...  
or think you may be  
please say so



MEASUREMENT OF THE GONAD DOSE OF INFANTS DURING X-RAY EXAMINATION OF THE  
HIP

N. Vana

Atomic Institute of the Austrian Universities,  
Schüttelstrasse 115, 1020-Vienna, Austria

and

P. Krepler and Ch. Harraneck

St. Anna-Children's Hospital

Kinderspitalgasse 6, 1090-Vienna, Austria.

1. INTRODUCTION

As the consequence that in most parts of Europe, at least 1% of dysplasia of the hip without severe dislocation do not show any clinical symptoms in early infancy even in repeated careful examination (1), the number of X-ray screening to detect these cases for early prophylactic treatment increases in the last years. During these radiological examinations of the hip joints a special lead shield of 1.5 mm Pb with a fenestration can be used to protect the gonads (2). This window allows the determination of all parts of skeleton to make a correct diagnosis while all other parts, especially the gonads, are safely shielded. To improve protection against scattered radiation an additional lead shield is used beneath the tests while examining boys. To check the effectiveness of this gonad protection direct dosimetric studies on the patient during X-ray examinations were performed.

2. METHODS AND MEASUREMENTS

The measurements of radiation dose were done with LiF (TLD-100) extruded chips and  $\text{CaF}_2:\text{Dy}$  (TLD-200) crystals with dimensions  $6.35 \times 6.35 \times 0.9 \text{ mm}^3$ . The read out of the thermoluminescence dosimeters was performed with a modified EG & G system using a special selected program for the heating cycle (3) the dosimeters were calibrated in the radiation field of a Co-60 source under the consideration that the requirements for electron equilibrium in a tissue equivalent material (polyethylene) are satisfied. The exposure TL-response of the LiF-dosimeters was measured between 1 mR and 100 mR and of the  $\text{CaF}_2:\text{Dy}$  dosimeters in the region of 50  $\mu\text{R}$  to 70 mR (4). In the Co-60 radiation field the standard deviation of the measurements was in the exposure range of about 10 mR, 5% for the LiF-dosimeters and 4.5% for the  $\text{CaF}_2$ -dosimeters. Because of the large fluctuation of the non radiation induced thermoluminescence in the exposure region below 1 mR the standard deviation increases to 25% for the LiF- and to 10% for the  $\text{CaF}_2$ -dosimeters.

Since our examinations were not performed in a Co-60 radiation field, but with diagnostic X-rays, the measured exposures had to be corrected for the relative sensitivities of the thermoluminescence dosimeters. At energies below 100 keV the sensitivities of TLD-100 and TLD-200 increases compared to Co-60 radiation. The energy dependence of both the dosimeters was measured with a monochromator and the filtered bremsstrahlung from a gold target excited by electrons from a Van de Graaff accelerator (4) the final sensitivity correction factors for the dosimeters were estimated

with so called tandem measurements. During all examinations one TLD-100 and one TLD-200 dosimeter wrapped in a black plastic foil (polyethylene 5.35 mg/cm<sup>2</sup>) were attached to the skin in front of the X-ray diagnostic machine as well as on the rear side. Therefore both dosimeters are exposed simultaneously in the same diagnostic X-ray energy region and indicate the identical exposure. From the ratio the different energy response of both dosimeters - the thermoluminescence light emitted from the LiF and the CaF<sub>2</sub> is different in its intensity - the effective energy of the X-ray spectrum at the site of the dosimeter can be inferred. The measured energy response of the dosimeters allows the estimation of the correction factor for the both dosimeters. The correction factor of TLD-100 was estimated about 1.3, the correction factor of TLD-200 varies from 8.5 to 10. Due to the uncertainty in the correction factor the standard deviation of the measurements with CaF<sub>2</sub> as well as with LiF increased to 10% in the 10 mR region and up to 20% in the exposure region below 1 mR. Finally, a factor of 0.9; rad per R was used for the conversion from exposure to tissue dose.

### 3. GONAD DOSE

#### 3.1. Testicle dose

The examinations of the hip were performed with diagnostic X-rays generated at 50 kV and 65 kV. In the consequence of the different thickness of the several patients the parameters of the X-ray generator had to be varied in general. The focus-film distance was 100 cm. For measuring the testicle dose the dosimeters wrapped in a black plastic foil were attached behind the scrotum. During the X-ray examinations the scrotum was shielded with an additional 1 mm lead protection at the flanks and the rear to reduce scattered radiation.

Generator parameters		Dose	Range
kV	m As	mrad	mrad
65	2.5	0.15±0.08	<0.02-0.35
50	6.3-8	0.23±0.2	<0.02-0.65

TABLE 1 Dose behind the scrotum, testicle dose

The maximum exposure measured with displaced scrotum protection was 0.65 mrad.

#### 3.2. Estimation of the ovary dose

TLD-200 dosimeters wrapped in black plastic foil were attached at the end of a rubber tube and put into the rectum of the patient up to about 7 cm above the anus. 2 cm from the dosimeter a lead mark was fixed which was generally shielded by the 1 mm lead gonad protection during the X-ray examination. The correction factor of the dosimeters could be calculated from the effective energy determined from tandem measurements on the skin in front of the X-ray machine as well as on the rear side. Depending on the position of the dosimeters and the variations of the X-ray adjustments the absorbed dose in the rectum varies between 0.4 and 1 mrad. The mean absorbed dose was determined to be 0.6 ± 0.3 mrad.

Generator parameter		Dose	Range
kV	m As	mrad	mrad
65	2	0.55 0.3	0.4 - 1
65	2.5	0.7 0.11	
50	6.3 - 8	0.6 0.3	0.3 - 1

TABLE 2 Measured dose in the rectum, ovary dose.

### 3.3. Dose using high intensifying screen-film combinations

During a lot of examinations high intensifying screen-film combinations (Trimax alpha 4 screen together with Trimax XM-film) was performed. Using this combination the detail visibility was not influenced and after adjustment to 60 kV and 1 mAs the same grade of blackening was obtained as in the former examinations. The mean dose measured in the rectum was  $0.12 \pm 0.04$  mrad and the dose at the scrotum varied from values of an elevated background to 30  $\mu$ R - 70  $\mu$ R.

### 4. CONCLUSION

These measurements of the testicles and ovaries doses of young infants during X-ray examination of the hip show that the used simple fenestration method is an effective gonad protection. Additional one can reduce most effectively the gonad dose by using high intensifying rare earth screen-film combinations. The gonad dose obtained for one X-ray photograph of the hip with high intensifying screens for girls is equivalent to the natural radiation dose of 1/2 day and for boys of 1/10 - 1/3 day.

### REFERENCES

- (1) SCHWÄGERL, W., KREPLER, P., FLAMM, CH., Vergleichende klinische und röntgenologische Untersuchung zur Erfassung von Hüftdysplasien im Säuglingsalter, Z. Orthop. 113 (1975) 19
- (2) KREPLER, P., Ein spezieller Gonadenschutz für Hüftvergleichsaufnahmen bei Säuglingen, RÖ-Blätter 29 (1976) 309
- (3) VANA, N., AIGINGER, H., TSCHELIESNIG, P., Low Dose Measurements with Thermoluminescence Dosimetry, AIAU-Report 7501, 1975
- (4) VANA, N., AIGINGER, H., ERATH, W., Measurements of Doses in the 1 mrad Range by Means of LiF, CaF<sub>2</sub> and CaSO<sub>4</sub> Dosimeters and Determination of the Energy Response of LiF and CaF<sub>2</sub>, 4th International Congress of the IRPA, Paris 1977, Comm.N 371

## PATIENT DOSES IN PAEDIATRIC RADIOLOGY

M. Fitzgerald\* , A . R. Chrispin + and Miss M. Riocreux+.

\* Radiation Physics Department, St. Bartholomew's Hospital, London

+ Department of Paediatric Radiology, The Hospital for Sick Children  
Great Ormond Street, London.

It is well known that medical irradiation makes the greatest contribution to the genetically significant dose arising from man-made sources of radiation. Little information has appeared in the literature in recent years regarding the contribution made by paediatric radiology.

A survey is currently in progress to assess the doses received by children undergoing diagnostic radiology in a modern, well equipped paediatric xray department in which rare- earth intensifying screens are used. The survey was designed in two parts, the first dealing with direct radiography only and the second with examinations involving indirect radiography and fluoroscopy.

In the first part, lithium fluoride powder dosimeters were used to measure the incident dose at the centre of each xray field on each of approximately 1000 patients. Details of the child's weight and height, the depth of the body cross-section being examined and the separation of the gonads from the field centres were recorded, together with the xray factors and the field sizes used.

Preliminary results from the survey of direct radiography are presented giving details of the skin doses received and their variation with examination type, age and size.

#### Acknowledgement.

It is a pleasure to acknowledge the patience of the radiographers at the Hospital for Sick Children who were largely responsible for the recording of the data.

## Notes



**ASSOCIATION INTERNATIONALE DE RADIOPROTECTION  
INTERNATIONAL RADIATION PROTECTION ASSOCIATION**

**IV<sup>e</sup> CONGRÈS INTERNATIONAL  
IVth INTERNATIONAL CONGRESS**

**RECUEIL  
DES COMMUNICATIONS**

VOLUME 4 - Vendredi 29 avril

---

**PROCEEDINGS**

VOLUME 4 - Friday April 29th

---

**PARIS 24-30 AVRIL 1977**

BASIC PRINCIPLES FOR THE LIMITATION OF  
RELEASES OF RADIOACTIVE SUBSTANCES INTO THE ENVIRONMENT

Bo Lindell

National Institute of Radiation Protection  
Stockholm, Sweden

## 1. INTRODUCTION

The expansion in the generation of nuclear power has justified a revision of the principles for the limitation of releases of radioactive substances into the environment. An advisory group of experts to the International Atomic Energy Agency have reviewed the concepts and criteria which would be of use in the decision-making by national authorities. Their report will be published by the Agency. The author has been asked to summarize the basic concepts and criteria. It is inevitable that any attempt to summarize advices in such a difficult field will be subjective and may inadvertently deviate from the carefully balanced document summarized. This summary, therefore, only serves as an introduction to a discussion and a call for attention to the document expected from the IAEA. Those who are interested should look for the original document.

The development of a new approach for setting discharge limits for radioactive substances should not be taken to imply that the previous practice has been unsatisfactory under the conditions it has been used. On the contrary, the past practice has been quite appropriate in the situation where the number of installations emitting radioactive substances has been small.

This situation, however, has changed. The number of nuclear installations is increasing to the extent that it becomes important to consider not only local but also global exposures. The nuclear debate forces national authorities to compare the environmental and health effects of all the various sources of energy. The practice of making "safe" estimates of environmental radiation doses introduces a bias in comparative cost-benefit analyses, which means that previous margins of safety might be removed. There is also a need to extrapolate the trend of expansion in nuclear power generation into the future and assess the future doses which will inevitably follow as the consequence of the assumed expansion rate unless a new release policy is formulated.

## 2. BASIC PROTECTION CRITERIA AND PRINCIPLES

The policy of the IAEA is to conform with the dose limitation system of the International Commission on Radiological Protection (ICRP). The basic recommendations of the ICRP were published in ICRP Publication 9 in 1966, but are expected to become superseded by new recommendations to appear in 1977 in ICRP Publication 26. The development in basic policy was illustrated in ICRP Publication 22 (1973), where the Commission stressed the importance of the recommendation to keep all radiation doses as low as it is reasonably achievable.

There are three major conditions which should be fulfilled before an installation which emits radioactive substances into the environment is accepted. These are

- (a) The ICRP dose limits for individual members of the public shall be respected,
- (b) As any radiation exposure may involve some degree of risk, the expected harm should be balanced by benefits which justify the practice causing the exposure, and
- (c) All doses should be kept as low as it is reasonably achievable, social and economic considerations taken into account.

Conditions (b) and (c) presuppose assumptions on the dose-response relationship. The available information has been reviewed from time to time by the United Nations Scientific Committee on the Effects of Atomic Radiation (UNSCEAR) and in some ICRP reports.

### 3. THE CHOICE OF RELEASE LIMITS

In past practice, condition (a) above has been the main basis for the derivation of release limits. The derived limit for release has been the limit which has resulted in the ICRP dose limit for individual members of the public just being reached in the critical group.

The limit actually set by the authorities, the authorized operational limit, has often been chosen lower than the derived limit, either by the application of a safety factor due to uncertainties in the adopted environmental model or simply because of no demonstrated need for higher values.

In the procedure now recommended, condition (a) may still be the limiting factor in the setting of the authorized operational limit. It is pointed out, however, that it is essential to take account of both long-lived environmental contamination and expected future radiation sources when limiting the discharges of present practices.

Condition (c) calls for optimization of releases. The method of determining the optimal level of radiation protection is called differential cost-benefit analysis or cost-effectiveness analysis. Ideally, the authorized operational limit should be set equal to the optimal release level, provided that condition (a) will still be met. In practice, insufficient information may not always make an optimization process possible.

Condition (b) calls for a cost-benefit assessment of the practice in relation to alternative practices, in order to establish whether the practice is justified. The justification of a practice which may result in radiation exposure is beyond the scope of the procedures discussed here. It should be noted, however, that cost-benefit analyses will usually have to be carried out in situations where benefit and risk are not shared by the same individuals. This is only appropriate under the boundary condition that no individual is exposed to unacceptable risks, *i.e.* under condition (a).



#### 4. LIMITS BASED ON DOSES TO INDIVIDUAL MEMBERS OF THE PUBLIC

Experience has shown that, when radioactive substances are released into the environment, a few radionuclides and exposure pathways will be more important than others and will be responsible for most of the highest doses to individuals. These radionuclides and pathways are called "critical" and the group of individuals which, because of common characteristics such as age, sex, location, food habits etc. receive the highest doses is called the critical group.

The discharge rates from a nuclear installation usually vary with time. In addition, the characteristics of many environmental pathways show pronounced seasonal variations. It is therefore necessary to select a long enough time, usually one year, as the averaging period for the limitation of the release rate.

The derived annual limit of release<sup>1)</sup> is a release which, if repeated indefinitely, would result in annual doses in the critical group equal to the ICRP annual dose limits for individual members of the public. This means that the annual limit of release is a release which would cause a dose commitment in the critical group equal to the ICRP annual dose limit. The dose commitment is the infinite time integral of the average dose rate caused by a practice (e.g. one year's release) in a specified population (in this case the critical group). If the dose commitment is to be related to the ICRP dose limit, which is strictly a dose equivalent limit, it is the dose equivalent commitment that should be limited:

$$H_C^C = \int_0^{\infty} \dot{H}(t) dt < ADL$$

In this expression  $H_C^C$  is the dose equivalent commitment for the critical group from one year's release,  $\dot{H}(t)$  the dose equivalent rate in the critical group and ADL the ICRP annual dose (equivalent) limit.

The above formula would apply to the dose in the organ which is critical in relation to the radionuclide under consideration, provided that one radionuclide dominates the exposure. With this limitation, the release could continue indefinitely without the ADL being exceeded in the future. There is one additional condition, however. The ICRP ADL is intended to limit the total doses from all manmade sources of radiation with the exception of doses given to patients in medical procedures. Each critical group may receive exposures from several sources. The ADL is therefore not "available" or appropriate to use as the basis for the limitation of the contribution from any one single source. The authorities will need to take possible other exposures, including those from future sources, into account. This calls for the application of a "safety factor".

There is an additional complication in that some radionuclides have extremely long half-lives. They may therefore cause large dose commitments even though the maximum future annual dose will be quite small.

<sup>1)</sup> formerly referred to as the "capacity of the environment"

For such long-lived radionuclides it would not be realistic to assume a continued practice over a time period sufficient to cause a steady-state situation with the annual dose equal to the dose commitment from one year of practice. It would therefore be unnecessarily restrictive to limit the releases on the basis of the full dose commitment from one year's release. The appropriate limitation may be achieved by limiting the time integral of the dose equivalent rate in the critical group over a time ( $\tau$ ) equal to the estimated duration of the practice:

$$\int_0^{\tau} \dot{H}(t) dt < ADL$$

For controlling the annual dose in the critical group, the integration should be carried out over the foreseen operational time of all nuclear installations substantially contributing to the exposure of the relevant critical group. The integral is sometimes referred to as the "incomplete" dose commitment. Because of the long-term dispersion of the long-lived radionuclides, however, this approach is often of more importance in the case of global contamination than for local exposures.

The movement of radionuclides from the source can be described by environmental models of varying complexity. In "systems analysis", the assessment is based on compartment models, in which the rates of transfer of radioactive substances are specified by constants or by time functions. By using systems analysis it is possible to predict environmental contamination levels and dose rates for various segments of the population as a function of time.

In most practical cases, however, it is sufficient to know the dose commitment of a given release, i.e. the time integrals rather than the time functions.

If the movement of radionuclides in the environment is described by a non-feedback transfer model, knowledge of the transfer factors as defined by UNSCEAR will suffice for the assessment of the time integrals. In general, these transfer factors are defined as quotients between time-integrals of quantities linearly related to dose, in different compartments; for example:

$$f_{uv} = \frac{\int_0^{\infty} C_v(t) dt}{\int_0^{\infty} C_u(t) dt}$$

where  $f_{uv}$  is the transfer factor relating compartments  $u$  and  $v$  and  $C_u(t)$  and  $C_v(t)$  are the concentrations in the compartments at time  $t$ .

In the case of continuous release at a constant rate, the same transfer factors would cover the steady state condition, so that

$$C_v = f_{uv} C_u$$

In the aquatic environment, predicted concentrations in the receiving water mass are converted by use of the appropriate concentration factors to concentrations in critical environmental materials. These factors are known for a wide range of materials and radionuclides from actual operational situations, or have been determined experimentally or by stable nuclide analysis in steady state conditions. For atmospheric releases, after calculation of concentrations in air, estimates may have to be made of the relationship between concentration in ground-level air and activity levels in vegetation and in food products derived from grazing animals.

The end result of a critical pathway analysis can be summarized by a set of factors  $f_{jklm}$ , relating the discharge from source  $k$  to the resulting dose commitment from nuclide  $l$  in organ  $m$  of individuals in group  $j$ :

$$H_{jklm}^D = f_{jklm} R_{kl}$$

In the simplest case, only one source  $k$  and one critical nuclide  $l$  have to be considered, and the critical group  $j^*$  is the one giving the lowest value of the quotient  $ADL_m / f_{j^*klm}$ . Provided that annual values may be used for the  $f$ -factors, the derived annual release limit  $R_{kl}^*$  may then be calculated as

$$R_{kl}^* = ADL_m / f_{j^*klm}$$

If there are more than one source and several nuclides which contribute significantly to the exposure of the critical group, the release values will have to satisfy the following condition for all organs  $m$ :

$$\sum_k \sum_l f_{j^*klm} R_{kl} < ADL_m$$

with  $j_m^*$  denoting the critical groups for each organ  $m$  in respect to the combined release of the various nuclides from the various sources.

The actually permitted releases will normally be far below the values corresponding to the ICRP dose limits. It is therefore as a rule advantageous to use simplified assessment procedures that under-estimate the permissible release values.

The calculation is complicated by the fact that ICRP in its Publication 9 refers its dose limits to "critical organs". The release limit will therefore be based on the organ dose and the group where the quotient of  $\sum_k \sum_l f_{j^*klm} R_{kl}$  and  $ADL_m$  is highest.

If this recommendation were to be changed, along the lines suggested by Jacobi, so that only one dose limit ADL were to apply to a weighted whole body dose

$$H_{WB} = \sum_m w_m H_m$$

then the release values  $R_{kl}^*$  satisfying the dose limit conditions would, with a margin of safety  $\alpha$  given by

$$\sum_k \sum_l \sum_m w_m^2 j^m(klm) klm R_{kl}^* = ABW$$

where  $j^m(klm)$  indicates the population group receiving the highest dose in organ  $m$  due to nuclide  $l$  and source  $k$ .  $R_{kl}^*$  will not uniquely determine anyone release limit value but is part of any set of release values which, combined, will constitute a release at the limit. The fact that  $j^m(klm)$  implies addition of weighted organ doses in different critical groups brings in a margin of safety but the selection of the highest organ doses irrespective of critical group greatly simplifies the calculation.

With a very large number of sources distributed all over the world, the global contamination could conceivably become a problem and it would be prudent to make the above assessments also for the whole world population as the critical group.

The global per caput dose rate  $\dot{H}_m$  in organ  $m$  may be assessed as

$$\dot{H}_m = \frac{1}{N} \sum_k (S_1^c)_k Z_k$$

under steady state conditions, if  $N$  is the world population,  $(S_1^c)_k$  is the collective dose equivalent commitment per unit of practice of source  $k$  (e.g. the production of 1M/year of electric energy), and  $Z_k$  is the rate of practice of source  $k$ .

The use of the collective dose commitment as a tool for deriving the future per caput dose rate in the whole world population is not based on any biological assumptions but is simply a mathematical step in the calculation of an average. The collective dose commitment may be written as

$$S^c = \int_0^{\infty} \dot{S}(t) dt$$

where the collective dose rate  $\dot{S}(t)$  may be derived as

$$\dot{S} = \int_0^{\infty} R N_{\underline{H}}(\dot{H}) d\dot{H}$$

where  $N_{\underline{H}}(\dot{H})$  is the population spectrum in dose rate. It is essential that the integration is carried out in full, without any cut-off value of the individual dose rates  $\dot{H}$ , as long as the continued summation adds significantly to the integrated value.

For long-lived radionuclides the steady state condition will never be reached and it will suffice to calculate the incomplete collective dose commitment, integrating over the estimated use period of nuclear power. The value of 500 years has been used in some assessments.

## 5. LIMITATION BASED ON OPTIMIZATION PROCEDURES

For cost-benefit assessments and cost-effectiveness assessments it is necessary to make some assumption regarding the dose-response relationship for radiation-induced harm. At the low doses of radiation that would occur below the dose limits, the only risk is that of late stochastic effects such as the induction of cancer and genetic disease. It is the normal practice in radiation protection to adopt the assumption that the risk of such effects is proportional to the increment of dose.

ICRP defines radiation health detriment in a population as the mathematical expectation of harm, taking into account not only the probability of each type of deleterious effect but also the severity of the effects.

The detriment  $G_{k1}$  of a unit practice of a source  $k$  may be written

$$G_{k1} = \sum_j N_j \sum_i p_{ijk} g_{ij}$$

with  $p_{ijk}$  being the probability of an individual suffering the effect  $i$ , the severity of which is expressed by a weighting factor  $g_{ij}$ , and  $N_j$  being the number of persons in each population group  $j$ . The probabilities  $p_{ijk}$  will be proportional to the average dose in each group  $j$  (assuming in this example whole body exposure):  $p_{ijk} = r_{ij} H_{jk}$ , where  $r_{ij}$  is a risk factor.

The values of  $r_{ij}$  and  $g_{ij}$  may depend upon, for example, the age structure in each population group, but it is often possible to assume a common set of values  $r_i$  and  $g_i$  for all groups. The detriment may then be assessed as

$$G_{k1} = \sum_j \sum_i N_j H_j r_i g_i = \sum_j S_j \sum_i r_i g_i = S \sum_i r_i g_i$$

If the doses are different in different organs, the total detriment will consist of the sum of detriments caused by the irradiation of a number of organs. Each component of the detriment, however, is proportional to the collective dose in the corresponding organ.

For comparison with benefits when assessing the justification of a source, or with costs involved in the reduction of a given exposure level, it is convenient to assign a monetary value to the collective dose unit. This could be attempted using different approaches, such as to give a value to the sum  $\sum r_i g_i$  by actually assessing the impact on society by the deleterious effects of concern, or by observation of the values society is actually willing to pay to reduce collective doses in given practices. Several assessments of the cost equivalent of one manrem have been published in the literature, with values ranging from £ 10 to £ 1000. Recently the US Nuclear Regulatory Commission set an interim value of \$ 1000 on the benefit derived from eliminating one manrem whole body dose from environmental exposures caused by nuclear installations.

The optimal level of protection is reached when the additional cost of achieving further reduction in the collective dose commitment from a given source or set of sources outweighs the decreased cost to society

of the detriment arising from the eliminated doses. Or, in other words, a further reduction in collective dose commitment is only reasonable if it can be achieved at a lower cost per manrem than a reference value such as one of those mentioned above.

If the authorized operational release limit is set on the basis of an optimization assessment it is necessary to remember the boundary condition that the individual dose limits must be respected. It is only on this condition that the inequities in the distribution of benefits and detriments to different population groups can be accepted.

The principles discussed here are generally applicable and could well be applied also in the limitation of non-radioactive pollutants. If these are not controlled and evaluated at the same level of ambition as the radioactive pollutants, there will be a continued bias in comparison of the environmental and health effects from radioactive and non-radioactive pollutants and of the sources causing the pollution.

#### REFERENCES

- (1) INTERNATIONAL ATOMIC ENERGY AGENCY. Report of Advisory Group to Consider Principles for Establishing Limits for the Release of Radioactive Material into the Environment. IAEA, Vienna. To be published.
- (2) INTERNATIONAL COMMISSION ON RADIOLOGICAL PROTECTION. Recommendations of the ICRP. Publications 9 (1966), 22 (1973) and 26 (1977). Pergamon Press, Oxford.
- (3) UNITED NATIONS SCIENTIFIC COMMITTEE ON THE EFFECTS OF ATOMIC RADIATION. Reports to the UN General Assembly, 1958, 1962, 1969, 1972 and 1977. United Nations, New York.
- (4) JACOBI, W.: How shall we combine the doses to different body organs? Commission of the European Communities, International Symposium of Aviemore, 2-6 June, 1974. EUR 5397e(1975).

DOSE-EFFECT RELATIONSHIPS FOR LIFE SHORTENING, TUMORIGENESIS,  
AND SYSTEMIC INJURIES IN MICE IRRADIATED WITH  
FISSION NEUTRON OR  $^{60}\text{Co}$  GAMMA RADIATION

E. J. Ainsworth, R. J. M. Fry, F. S. Williamson,  
P. C. Brennan, S. P. Stearner, V. V. Yang,  
D. A. Crouse, J. H. Rust, and T. B. Borak

Division of Biological and Medical Research  
Argonne National Laboratory  
Argonne, Illinois 60439

## 1. INTRODUCTION

This presentation summarizes new information on life-span studies and pathological changes, which include late injury in the immune and vascular systems, after fission neutron or gamma irradiation. The objectives of these studies are: (1) to provide data on dose-response relationships for carcinogenesis, life shortening, and other late diseases or injuries that may be used for predictive modeling for radiation risk assessment; and (2) to increase understanding of late radiation effects on cell populations in relation to life-shortening diseases. Several interim reports of results from this JANUS Program have appeared previously (1-3), but new data and analyses are presented here.

## 2. MATERIALS AND METHODS

B6CF<sub>1</sub> mice (C57B1/6 x BALB/c) were exposed singly to either fission spectrum neutrons from the JANUS reactor or  $^{60}\text{Co}$  gamma radiation at ~ 115 days of age. When the effects of protracted (fractionated) doses were assessed, the first fractionated dose was given at ~ 115 days of age. Details of radiation facilities, dosimetry, dose rates, and experimental protocols have been published elsewhere (1-3) and are given below, as needed. The energy distribution of fission neutrons from JANUS has a flux average of 0.85 Mev. Although the midline tissue doses (MTD) for neutrons presented here and previously are based on a factor of 0.80 to convert tissue kerma in air to MTD, new information indicates a better estimate for an active 30-gm mouse is 0.85. Also, the dose-weighted linear energy transfer at the midline has a mean of 73 keV/ $\mu$  with 94% of the energy deposited in a 1-micron tissue sphere from event sizes greater than 10 keV/ $\mu$ . Comprehensive literature citations are provided elsewhere (1-3), so only recent references are included in this paper.

## 3. RESULTS

### 3.1. Single-Dose Response: Excess Mortality Rates

Mortality data for females are shown in Fig. 1. Mortality rate is approximated by the reciprocal of the mean survival time (4), and excess mortality rate, i.e., the difference between irradiated and control animals, is plotted as a dependent variable on log-log coordinates. At the neutron doses of 20, 80, and 240 rad, excess mortality showed a slope, 0.6, significantly lower than unity, which indicates a departure from strict total-dose dependence. A similar slope was observed for males. The effect of neutrons on excess mortality decreases with increasing dose. Consequently, if linear coordinates are used, effects at low doses will be underestimated by linear extrapolation of results from high doses. The slope may change to 1.0 at doses below 20 rad, but Mole (5) has used a continuously bending curve, consistent with a slope of < 1.0, to describe the responses of selected leukemias in man (6).

Although many cellular responses to neutrons show total-dose dependence over a broad range (5), dose-response curves of less than 1.0 have been reported for mutations in wasp oocytes (7) and for mammary tumors in rats (8). We have commented previously on factors that may contribute to the slope of the neutron dose-response curves we observe (1-3). The excess mortality after single gamma doses of 90, 268, or 788 rad appeared approximately total-dose dependent, slope  $\sim 1.2$  for both sexes; the data for females are shown in Fig. 1.

### 3.2. Excess Mortality Rates after Protracted Doses

Strictly quadratic dose dependence was observed for mice and dogs given duration-of-life gamma irradiation (4). Approximately quadratic kinetics, slope 1.7, prevailed when protracted gamma doses were administered in 24 weekly fractions over 23 weeks (Fig. 1). Quadratic kinetics were not expected to extend to a weekly dose of 35 gamma rad (845 rad) based on the previous observation that linear kinetics prevailed in this mouse strain when weekly doses of this magnitude or higher were administered in  $\sim 56-70$  hrs/wk for duration of life (4). Additionally, excess mortality produced by fractionated doses of 35 rad/wk was quite similar to values obtained when the same approximate weekly doses were administered for duration of life (4). Consequently, either weekly exposures of 45-min duration are more effective than when the similar weekly dose is administered in  $\sim 56-70$  hrs, or some portion of the dose sustained in duration-of-life exposures contributes little to life shortening.

When a total dose of 240 neutron rad is administered in 24 fractions of 10 rad over 23 weeks, the excess mortality is higher than when the same single dose was given (Fig. 1). This phenomenon, referred to as "enhancement," also occurred in males when total fractionated doses of 80 or 240 rad were given. Enhancement has been observed previously for life shortening (1,9), cancers (1,10,11), or mutations (12), but the dose range over which the phenomenon occurs is undefined.

Based on excess mortality or life shortening, RBE will be a function of dose after single or protracted exposures. After single doses between 20 and 240 neutron rad, RBE for life shortening conforms to a slope of  $-0.5$  (5,8) and RBE ranged from  $\sim 2-8$  (1). Under conditions of dose protraction we estimate RBE at 10-12, based on similar excess mortality following weekly doses of 3.3 neutron and 35 gamma rad (1). Higher RBE values are expected at lower fractionated doses.

### 3.3. Total-Dose Dependence under Conditions of Protracted Irradiation

Total-dose dependence, the linear term in the linear-quadratic relationship,  $\alpha D + \beta D^2$ , was evaluated for both fission spectrum neutrons and gamma radiation; similar total fractionated doses were given by irradiating animals 3 times/wk, once/wk, once/wk at a dose rate reduced 8-fold, or once/4 wks. Results in Table 1 show that decreasing the instantaneous dose rate per fraction by a factor of  $\sim 8$  had no significant effect on life shortening for either radiation quality (comparison between groups B and E). When the total doses of either radiation were given in 6 fractions (group H), the life-shortening effects differed slightly but significantly from the effects produced by either 24 or 72 dose fractions. In the case of neutron-irradiated mice, somewhat less life shortening was produced by 6 fractions of 40 rad in comparison with the other groups; and in the case of gamma radiation, 6 fractions of 140 rad produced more life shortening than did the other fractionation schedules. The linear term in the linear-quadratic model fails to account for departures observed from total-dose dependence under conditions of



fractionated neutron or gamma exposure. This emphasizes the importance of the interaction term  $\theta$  in the Sacher model (4).

#### 3.4. Relationship of Protraction Period to Life Shortening; Preliminary Results

Age at the time of irradiation influences sensitivity to the life-shortening effects of single doses of neutron or gamma radiation (1). Little is known, in relation to age or protraction period, about changes in sensitivity that occur during protracted irradiation. Preliminary mortality data are now available from an experiment in which the same total fractionated doses were administered over approximately 20% (23 wks) and 50% (59 wks) of the remaining life expectancy from 115 days of age (Table 2). Also, the weekly dose used for 59-wk exposures was continued for the duration of life to assess the effect of the incremental dose received after 59 weeks. Comparisons of mean survival time for animals exposed 59 weeks and for duration of life showed that radiation doses sustained after 59 weeks produces very little effect on survival time. The life shortening produced by duration-of-life exposure, at a given weekly dose level, can be produced by a lower total dose administered in 59 weeks. Comparisons between 23- and 59-week irradiations indicate that the increase in the irradiation period from 23 to 59 weeks lengthens the mean survival time to a greater extent in gamma- than in neutron-irradiated animals. These preliminary results are consistent with the hypotheses that: (1) doses sustained late in the life-span of the mouse contribute little to life shortening; (2) at doses below 417 rad, doses interact rather additively during the first 23 or 59 weeks; and (3) over the dose range studied, increasing the period of protraction produces more of a sparing effect on survival time for gamma- than for neutron-irradiated animals.

#### 3.5. Pulmonary and Harderian Gland Tumors

Determination of tumor responses is critical since excess cancer mortality may constitute the principal hazard at "low radiation doses." Consequently, cause-of-death judgments are made in our experiments so that relationships between excess mortality rates and excess cancer rates can be determined. Excess cancer rates constitute a more sensitive endpoint than does excess mortality. After a fractionated dose of 80 neutron rad, female mice showed no significant enhancement of life shortening (Fig. 1), but excess mortality rate from lethal pulmonary tumors was higher over the major portion of remaining life expectancy (Fig. 2). Differences in total incidence of lethal pulmonary tumors are difficult to demonstrate between irradiated and control animals, but appearance time and age-specific mortality are influenced markedly by dose and by neutron dose fractionation (Fig. 2). In contrast, both total incidence and appearance time of Harderian gland tumors are influenced in females by dose, radiation quality, and by neutron dose fractionation (Fig. 3). Based on incidence alone, the RBE at a single neutron dose of 20 rad is  $\sim 17$  (3). When fractionated doses of 80 neutron and 417 gamma rad were compared, the RBE was increased considerably due to the sparing effect of gamma dose fractionation. The point emphasized is that estimates of excess cancer risk must consider total incidence, appearance time, and the degree of malignancy of various tumor types.

#### 3.6. Immune and Vascular Responses

The immune, hematopoietic, and vascular responses are used as model systems to evaluate relationships between early tissue injury and late radiation effects in rapidly and slowly turning over tissues. Evaluations of cellular immune function in aged and aged-irradiated animals were based on the ability of transplanted lymphoid cells to induce the graft-versus-host (GVH) reaction

in vivo (Table 3). Mice that received fractionated neutron doses (group B, Table 1) tended to show a reduced capacity at all sample times to induce GVH reaction compared with aged controls or animals which received a single neutron dose. In contrast, gamma dose fractionation produced some sparing effect in comparison with the single doses. Qualitatively similar results, i.e., enhancement with fractionated neutron doses and sparing with gamma dose fractionation, were obtained in parallel studies which used spleens from the same donor mice to evaluate the response of splenic lymphocytes (in culture) after mitogenic stimulation with phytohemagglutinin and bacterial lipopolysaccharide. Late radiation effects on the vasculature are studied by light and electron microscopy and by alterations in vascular function. Vascular deterioration was observed which may contribute to degenerative diseases such as glomerulosclerosis and predisposition to cardiovascular accidents or arteriosclerosis. Coronary artery degeneration was prominent in both controls and irradiated animals at 18 months of age. Based on morphologic criteria, which include degeneration of smooth muscle, the extent of fibrosis, and accumulation of matrix, coronary artery damage was enhanced by neutron dose fractionation at neutron doses of 80 and 240 rad; conversely, gamma dose fractionation reduced the injury. The RBE under conditions of fractionated exposure (24 doses over 23 weeks) is estimated at  $\sim 10$  based on similar injury after weekly doses of 10 neutron and 112 gamma rad. The role played by vascular injury and degenerative diseases after "low" radiation doses has not been studied comprehensively. The present findings may be of interest to those concerned with vascular damage following radiation therapy.

#### 4. CONCLUSIONS

Predictive models are essential for estimation of excess risk of cancers or other deleterious late effects of low- and high-LET radiation at dose levels where epidemiological data for man are incomplete and where dose levels are too low for direct confirmation by animal experiments. Models must benefit from human data, from results with experimental animals, at least in a qualitative mode, and from some understanding of critical biological events at the molecular, cellular, and tissue levels. Although reliable methods for quantitative extrapolation of risk estimates from experimental animals to man remain a challenge, animal experiments provide data needed to test existing models, formulate new models, and increase understanding of pathogenesis of late effects. Some results presented here are consistent with existing models, viz. RBE for life shortening is inversely related to dose and conforms to a slope of  $-0.5$ , and excess mortality after protracted gamma irradiation follows quadratic kinetics. However, other findings depart from expectations from existing models, viz. a slope of  $0.6$  rather than  $1.0$  describes the relationship between neutron dose and excess mortality between 20 and 240 rad, and enhanced effects of neutron dose fractionation must be considered in formulation of new predictive models. The observation that dose-response kinetics for excess mortality after neutron irradiation departs from expectations derived from short-term cellular responses emphasizes the myriad biology interposed between energy deposition, tumorigenesis and/or other events that culminate in death of an animal.

#### 5. ACKNOWLEDGMENTS

In large measure the JANUS Program and results presented here result from a Divisional effort. Essential encouragement, guidance, and constructive criticism was provided by G. A. Sacher. Other important direct contributors were K. H. Allen, C. A. Bedwell, E. J. B. Christian, R. J. Flynn, C. A. Fox, T. E. Fritz, D. Grahn, G. L. Holmblad, J. S. Hulesch, E. G. Johnson, Jr., D. L. Jordan, W. T. Kicksels, L. S. Lombard, V. A. Ludeman, M. Miller, C. M. Poole, K. A. Rettman, A. R. Sallase, C. J. Smyros, E. F. Staffeldt, J. E. Trier, S. A. Tyler, and a cadre of Animal Care Specialists. This work was supported by the U. S. Energy Research and Development Administration.

Table 1: Total-Dose Dependence for Life Shortening (LS) and Mean Survival Time (MST) after Fractionated Doses of Fission Neutron or Gamma Radiation

Group	No. Fractions <sup>a</sup> X Dose/Fraction <sup>b</sup>	% Life Shortening and Mean Survival Time (+ Standard Error)				
		Males		Females		
		% LS	MST <sup>c</sup>	% LS	MST <sup>c</sup>	
Neutron <sup>f</sup>	A	72 x 3.3	36	546 ± 16	40	505 ± 15
	B	24 x 10.0	39	518 ± 14 <sup>d</sup>	41	499 ± 13
	E	24 x 10.0	36	544 ± 14	41	495 ± 12
	H	6 x 40.0	33	572 ± 14	37	528 ± 12 <sup>e</sup>
Gamma <sup>f</sup>	A	72 x 11.7	16	711 ± 15 <sup>d</sup>	18	690 ± 19 <sup>d</sup>
	B	24 x 34.9	19	691 ± 14	20	673 ± 16
	E	24 x 36.0	18	697 ± 14	18	687 ± 14
	H	6 x 140.0	22	666 ± 14	24	641 ± 14

<sup>a</sup>Exposure schedule: 3 doses/wk (M,W,F) for A; 1 dose/wk for B, E; 1 dose/4 wks for H; total exposure time was ~ 143 hrs for E and 18 hrs for all other groups. <sup>b</sup>Dose rate/fraction was 0.22 rad/min for neutron groups A, B, H, and was 0.028 for E; dose rate/fraction was 0.78 rad/min for gamma groups A, B, H, and 0.10 for E. <sup>c</sup>Mean survival times from 115 days of age for all sham-irradiated controls are 850 ± 7 days for males and 840 ± 7 days for females. <sup>d</sup>Differs significantly (P = < 0.05) from group H based on analysis of variance. <sup>e</sup>H group differs significantly only from pooled results from A, B, E groups. <sup>f</sup>Mean total fractionated doses were 240 neutron and 845 gamma rad.

Table 2: Effect of Dose Protraction over 23 or 59 Weeks or for Duration of Life on Mean Survival Time in Female B6C<sub>1</sub>F<sub>1</sub> Mice<sup>a</sup>

Total Dose	Dose/Fraction <sup>b</sup>		Mean Survival Time (Days) <sup>c</sup>		
	23 wks	59 wks	23-wk	59-wk	Duration-of-Life
40 fn	1.7	0.7	767	800	785
160 fn	6.7	2.7	588	603	640
417 γ	17.3	6.9	772	845	817
1918 γ	80	32	451	619	639

<sup>a</sup>Preliminary results based on the first 2-3 replicates that entered the experiment; mortality among sham-irradiated controls is not yet sufficient to estimate mean survival time. <sup>b</sup>24 doses over 23 wks or 60 doses over 59 wks; weekly doses given in 45 min; the weekly dose used for 59-wk exposure was continued for duration of life.

Table 3: Late Effects of Irradiation on Capacity to Initiate Graft-Versus-Host Reaction: Changes in spleen weight at 6 days produced in supralethally irradiated C<sub>3</sub>H mice<sup>a</sup> injected intravenously with 5 x 10<sup>6</sup> lymph node cells from aged or aged-irradiated B6CF<sub>1</sub> mice.

B6CF <sub>1</sub> Donors Days after:		C <sub>3</sub> H Spleen Weights (mg) <sup>b</sup>				
Last Fract. Dose	Single Dose	Aged Controls	240 rad Neutron		807 rad Gamma	
			Single	Fractionated	Single	Fractionated
1	169	76 ± 2	80 ± 5	69 ± 3	72 ± 6 <sup>d</sup>	89 ± 2 <sup>c</sup>
15	183	80 ± 6	84 ± 4	72 ± 4	73 ± 6	81 ± 5
63	231	86 ± 4	-	80 ± 6	88 ± 3	87 ± 3
139	307	77 ± 4	75 ± 4	63 ± 2 <sup>c</sup>	64 ± 3 <sup>c</sup>	72 ± 5
163	331	96 ± 4	88 ± 4	80 ± 5 <sup>c</sup>	84 ± 4 <sup>c</sup>	81 ± 1 <sup>c</sup>
258	426	96 ± 3	95 ± 3	86 ± 5	88 ± 4	96 ± 3
365	563	103 ± 2	111 ± 3 <sup>d</sup>	98 ± 4	97 ± 3	102 ± 6

<sup>a</sup>Mean spleen weight in C<sub>3</sub>H mice 6 days after irradiation was 38 ± 1 mg.

<sup>b</sup>Means ± standard error for 5-13 mice/point. <sup>c</sup>Differs significantly (P < 0.05) from controls. <sup>d</sup>Differs significantly from fractionated dose (24 fractions in 23 wks).

#### REFERENCES

- (1) AINSWORTH, E.J., et al., "Life shortening, neoplasia, and systemic injuries in mice after single or fractionated doses of neutron or gamma radiation", Biological and Environmental Effects of Low-Level Radiation, Vol. 1, pp. 77-92, IAEA, Vienna (1976).
- (2) FRY, R.J.M., AINSWORTH, E.J., Radiation injury: some aspects of the oncogenic effects, Fed. Proc. (in press; 36 5, March, 1977).
- (3) FRY, R.J.M., et al., "The effect of pituitary isografts on radiation carcinogenesis in the mammary and Harderian glands of mice", Biological and Environmental Effects of Low-Level Radiation, Vol. 1, pp. 213-226, IAEA, Vienna (1976).
- (4) SACHER, G.A., "Dose, dose rate, radiation quality, and host factors for radiation-induced life shortening", Aging, Carcinogenesis, and Radiation Biology (SMITH, K.C., Ed), pp. 493-517, Plenum, New York (1976).
- (5) KELLERER, A.M., ROSSI, H.H., RBE and the primary mechanism of radiation action, Radiat. Res. 47 (1971) 15.
- (6) MOLE, R.H., Ionizing radiation as a carcinogen: practical questions and academic pursuits, Brit. J. Radiol. 48 (1975) 157.
- (7) VON BORSTEL, R.C., "Partial-target mutagenesis and carcinogenesis", Biological and Environmental Effects of Low-Level Radiation, Vol. 2, pp. 361-371, IAEA, Vienna (1976).
- (8) SHELLABARGER, C.J., et al., "Rat mammary carcinogenesis following neutron or X-radiation", Biological Effects of Neutron Irradiation, pp. 391-401, IAEA, Vienna (1974).
- (9) STORER, J.B., Late somatic effects of ionizing radiation in mice as a function of dose, dose rate, and radiation quality, Radiat. Res. 59 (1974) 313.
- (10) LUZ, A., et al., "Estimation of tumour risk at low dose from experimental results after incorporation of short-lived bone-seeking alpha emitters <sup>224</sup>Ra and <sup>227</sup>Th in mice", Biological and Environmental Effects of Low-Level Radiation, Vol. 1, pp 171-181, IAEA, Vienna (1976).
- (11) ULLRICH, R.L., et al., The influence of dose and dose rate on the incidence of neoplastic disease in R/M mice after neutron irradiation, Radiat. Res. 68 (1976) 115.
- (12) BATCHELOR, A.T., et al., The reversed dose rate effect with fast neutron irradiation of mouse spermatogonia, Mutation Res. 4 (1967) 229.

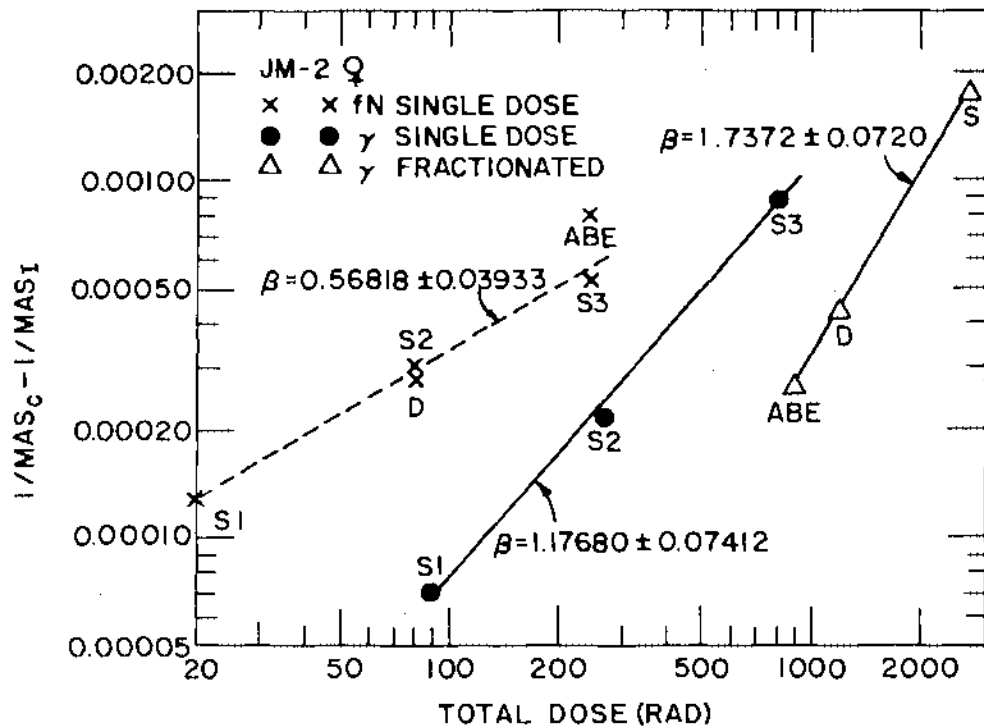

Fig. 1. Dose-response relationships for excess mortality rate in B6CF<sub>1</sub> male mice given single or fractionated doses of fission neutron or gamma radiation. Sample sizes ranged from 155-380 for single doses and 132-156 for fractionated doses. Results were pooled in groups that received 72- and 24-dose fractions (A,B,E) over 24 wks. Results from 5 groups of sham-irradiated controls, 849 animals, were also pooled.

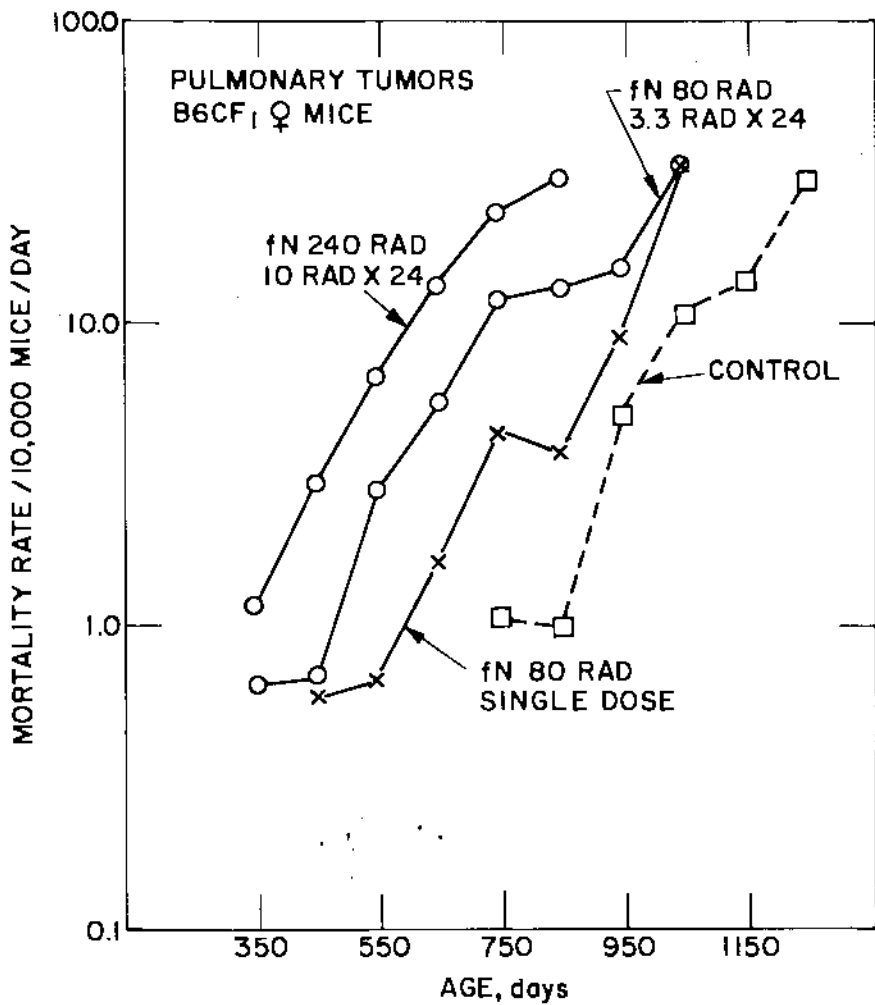

Fig. 2. Mortality rate from lethal pulmonary tumors in control and neutron-irradiated mice.

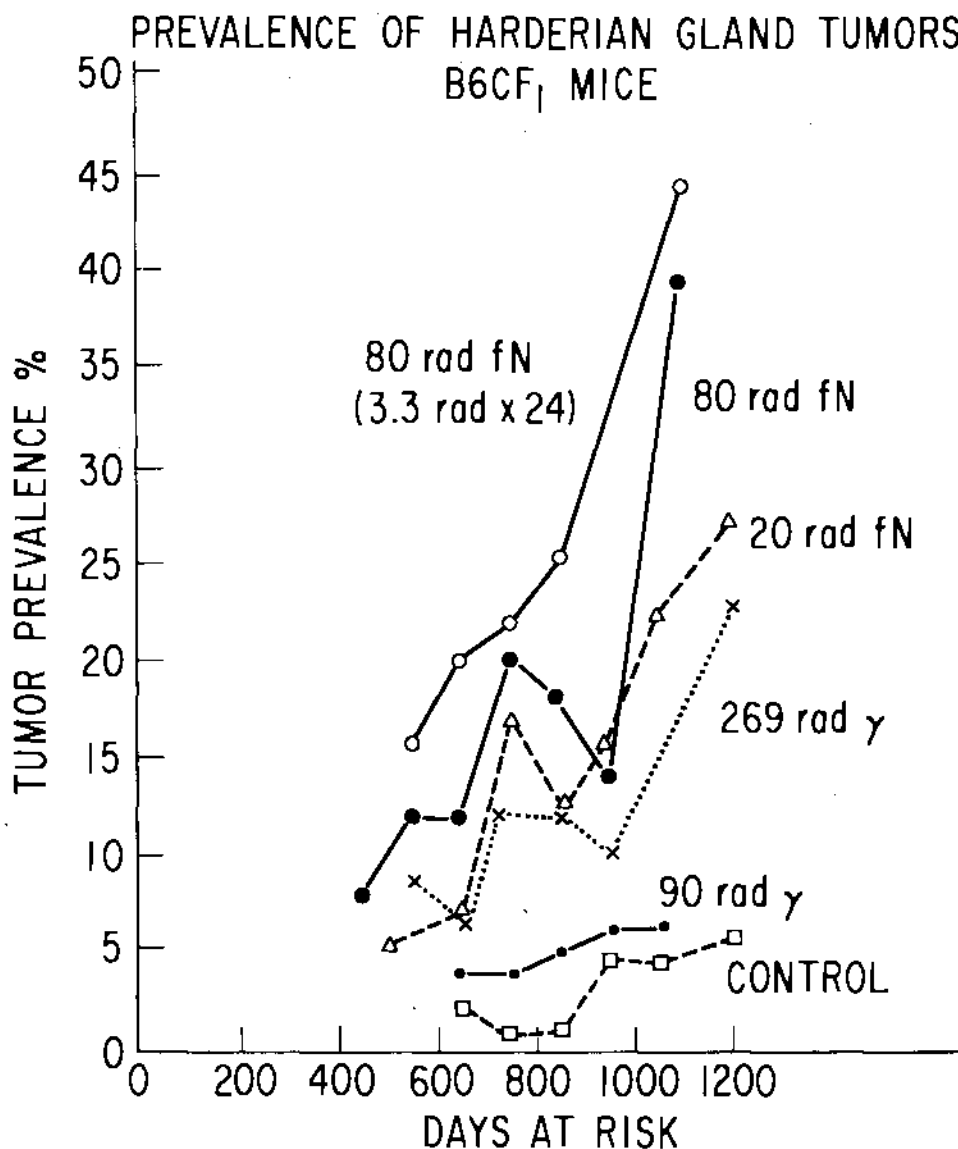

Fig. 3. Prevalence of Harderian gland tumors in control, neutron, and gamma-irradiated mice. Data presented elsewhere show that the fraction of the tumors which were the cause of death was affected also by dose, fractionation, and radiation quality (2).

ETUDE DES EFFETS D'IRRADIATION GAMMA CHRONIQUE ET CONTINUE A FAIBLE DEBIT DE DOSE SUR LA LONGEVITE DES SOURIS NUES ATHYMIQUES ET HETEROZYGOTES

H. METIVIER\*, R. MASSE\*, D. NOLIBE<sup>^</sup>, G. PORTAL\*\*\*, J. LAFUMA\*

\*C.E.A. - DPr/LTE - BP 561 - 92542 MONTROUGE CEDEX

\*\*C.E.A. - STEP/STID - BP 6 - 92260 FONTENAY AUX ROSES

-----

## I. INTRODUCTION

Parmi les effets tardifs des irradiations à faible dose et faible débit de dose, deux phénomènes sont en général évoqués : une diminution de la durée de vie nettement distincte des phénomènes de vieillissement accélérés (1), une augmentation de l'incidence tumorale (2) (3). D'une manière générale il est admis (4) (5) que la protraction de dose diminue considérablement le raccourcissement de la durée de vie. Cet effet résulte d'au moins deux facteurs : l'aptitude à la restauration cellulaire et la diminution de l'effet en fonction de l'âge (6). Les effets cancérigènes sont en général attribués à des mutations somatiques initiales combinées avec d'autres événements survenant en plusieurs étapes dans le tissu ou la tumeur prend naissance (7). Si cette hypothèse peut rendre compte de certaines observations elle ne permet de comprendre précisément ni la stricte interrelation du vieillissement et de l'action cancérigène : dans les séries de souris irradiées (3) la survie médiane est identique chez les animaux porteurs de tumeurs et les animaux indemnes ; ni le fait que les tumeurs induites dans ces lignées se font essentiellement dans les lignées cellulaires déjà susceptibles de donner ces tumeurs chez les témoins (3).

Dans l'expérimentation que nous présentons nous nous efforçons d'analyser la part possible revenant aux phénomènes cellulaires létaux et celle revenant à l'induction tumorale *sensu stricto* dans un lot d'animaux irradiés ne présentant pas de différence de survie par rapport aux témoins.

## 2. MATERIEL ET METHODES

340 souris Swiss hétérozygotes pour le gène nu (207 femelles, 133 mâles) et 222 souris nu athymiques ont été utilisées dans la proportion de un témoin pour deux irradiés. L'irradiation chronique a lieu 23 heures sur 24 heures, dans une quasi obscurité, une heure par jour les animaux sont éclairés durant les soins d'animerie. Les animaux irradiés sont déposés en quatre couronnes recevant 0,9-1,2-1,3-2,5 rads/jours. Les souris témoins sont dans la même pièce mais protégées de l'irradiation par un collimateur d'une part, et un mur de béton de 30 cm d'autre part. La dose délivrée dans la zone témoin est de 6,5 mrad/jours.

La dosimétrie est effectuée cage par cage à l'aide de dosimètres radiothermomoluminescents au fluorure de lithium.

Les souris classiques font l'objet d'un examen journalier et sacrificiels lorsque moribondes, autopsiées et les prélèvements fixés au Bouin Hollande, l'examen histologique est pratiqué selon les méthodes usuelles, les tumeurs à malignité suspecte ont été identifiées par greffe chez l'animal compatible.

Chez la souris nude les examens histologiques ne sont pratiqués qu'à titre de contrôle, les causes de mort en milieu conventionnel ont été analysées (8). Dans notre élevage les causes essentielles sont l'hépatite virale et les infections à mycoplasma.



TEMOINS	IRRADIEES
52%	75%

TABLEAU 1

NOMBRE MOYEN DE CANCERS PAR ANIMAL CANCEREUX	
TEMOIN	1,18
IRRADIEES	1,39

TABLEAU 2

0,9 rads/J (324-495 rads)	RAS	CANCERS
	24%	76% 1,26/animal
2,5 rads/J (900-1375 rads)	15%	85% 1,41/animal

TABLEAU 3

	TEMOINS	IRRADIEES
<u>SARCOMES</u>	57,5	50,8
Myo. Sarc. + Fibro. Sarc	17,5	8,5
Angio. Sarc.	7,5	6,8
Hemato. Sarc.	32,5	35,6
<u>CARCINOMES BRONCHIOLO-ALVEOLAIRES</u>	37,5	33,9
<u>CARCINOMES (autres)</u>	5	15,2

TABLEAU 4

CARCINOMES

	SARCOMES (HSA)	KBA	CARC.
0,9 rads/J (324-495 rads)	52 (36)	39	9
2,5 rads/J (900-1375 rads)	46 (29)	29	25

TABLEAU 5

	TEMOINS	IRRADIEES
CUTANES ET ANNEXES	2	9
DIGESTIF		4
SURRENALES		3
OVARIENS		2

TABLEAU 6

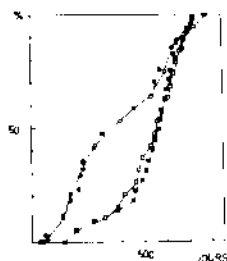

Fig. 1

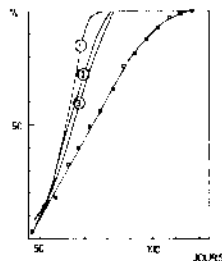

Fig. 2

### 3. RESULTATS

#### 1) Souris Swiss hétérozygote pour le gène nu

a/ L'examen de la figure 1 montre que la durée de vie n'est pas modifiée par une irradiation chronique comprise entre 0,9 et 2,5 rads/jours pour chaque sexe - survie moyenne des femelles sous irradiations 550 jours (495-1375 rads) - survie moyenne des mâles sous irradiations 360 jours (324-900 rads). L'espérance de vie maximum étant identique quelles que soient les conditions d'irradiation et de sexe; la différence moyenne entre sexe est liée à une différence de comportement. L'irradiation ne semble pas également modifier de comportement.

b/ Le tableau 1 montre par contre que l'incidence tumorale particulièrement élevée chez cette espèce (52% chez les animaux témoins) augmente d'environ 50% puisqu'elle atteint 75% chez les animaux irradiés (toutes doses regroupées). Le nombre moyen de cancers par animal est porté de 1,18 à 1,39 (tableau 2). En faisant intervenir la dose délivrée on s'aperçoit que l'incidence tumorale, ainsi que le nombre moyen de cancers par animal passe de 76% (1,26/animal) à 85% (1,4/animal). Si la dose délivrée varie de 0,9 à 2,5 rads/jours (tableau 3). Toutefois ces résultats doivent être actuellement pris avec certaines réserves étant donné le faible nombre d'animaux observés au niveau 2,5 rads/jour.

c/ La répartition des types tumoraux (toutes doses réunies) montrent une assez grande stabilité (tableau 4), exceptés le triplement des carcinomes extrapulmonaires. La décomposition en fonction des doses (tableau 5) souligne mieux que l'irradiation a rendu plus sensible la lignée K, avec l'apparition de cancers digestifs, ovariens et des glandes surrénales (tableau 6).

#### 2) Souris nue athymique

La survie moyenne des souris nues athymiques non irradiées est de 73 jours quel que soit le sexe dans nos conditions expérimentales. L'irradiation délivrée après 44 jours (sevrage de la souris nue) réduit la survie moyenne à 65 jours (0,9 rad/jours, soit une dose moyenne totale égale à 19 rads) ou à 61 jours (2,5 rads/jours, soit une dose moyenne totale égale à 43 rads). Ceci correspond à une baisse de 30 à 40% si on l'exprime en baisse de survie à partir de 44 jours (figure 2).

### 4. DISCUSSIONS

En conclusion ces premiers résultats donnent l'esquisse d'une réponse à l'effet des faibles doses de rayonnement  $\gamma$ ; Ils indiquent surtout qu'une approche théorique peut être effectuée au moyen de la souris nue. Cet animal est particulièrement sensible aux agressions. Il doit cette sensibilité à son déficit en T lymphocytes.

La comparaison des résultats de survie entre souris nues et souris hétérozygotes montre que les phénomènes de restauration ne doivent pas être systématiquement recherchés à l'échelle cellulaire. En effet, dans le modèle souris nue, la restauration fait défaut à faible dose et faible débit de dose or, on sait que la mort chez ces animaux est due à l'épuisement du stock non renouvelable des cellules B engagées dans la production d'anticorps (9). Donc, au moins pour le système des B lymphocytes, les cellules irradiées ne restaurent pas fonctionnellement. L'absence de ce phénomène chez les hétérozygotes même pour des doses cumulées beaucoup plus élevées suggère que la restauration est le fait d'une compensation tissulaire et non cellulaire par

engagement de nouveaux pools. Si on retient l'hypothèse que vieillissement et cancer sont intimement liées on peut de la même manière concevoir l'augmentation des tumeurs chez les hétérozygotes irradiées. La nature des tumeurs en effet n'est différente chez les irradiés et les témoins que pour certains types non dominants. Les cellules qui sont à l'origine des tumeurs spontanées traduisent le vieillissement de tissus qui ont plus ou moins engagé leurs réserves du fait d'altérations létales et sublétales des cellules qui les constituent. Un vieillissement général de l'animal ne peut être évoqué puisque aucune différence de durée de vie n'est observée chez les animaux irradiés et témoins. Le phénomène d'induction tumorale qui sous entend une mutation somatique n'est semble-t-il nécessaire que pour les carcinomes non représentés chez les témoins. Au minimum si l'on s'en tient à la mutation somatique on doit admettre que cet effet n'affecte qu'un nombre limité de lignées dont l'évolution spontanée conduit aux mêmes types de mutations ce qui restreint assez notablement l'intérêt prédictif de la théorie. Les résultats observés suggèrent que ce sont les facteurs du contrôle tissulaire qui sont essentiellement à l'origine des effets observés.

#### REFERENCES

- (1) ANDERSON, R.E., SCALETTI J.V., HOWARTH, J.L., *Exp. Geront.* 7 (1972) 289.
- (2) LESHER, S., SACHER G.A., GRAHN D., HAMILTON K., SALLESE A., *Survival of mice under duration-of-life exposure to gamma rays. II Pathologic effects*, *Rad. Res.* 24 (1965) 239.
- (3) UPTON A.C., RANDOLPH M.L., CONKLIN J.W., KASTENBAUM M.A., SLATER M., MELVILLE G.S., CONTE F.P., SPROUL J.A., *Late effects of fast neutrons and gamma-rays in mice as influenced by the dose rate of irradiation induction of neoplasia*, *Rad. Res.* 41 (1970) 467.
- (4) SILINE G., METALLI P., "Radiation and Ageing". In : *Proceedings of a colloquium held in Semmering Austria* (P.J. LINDOP, G.A. SACHER ed.), (TAYLOR et FRANCIS, Ltd., Red Lion Court, Fleet Street, London, E.C.4.), (1966) 207.
- (5) LANGHAM W.H., "Radiobiological Factors in Manned Space Flight", *National Academy of Sciences, National Research Council, Washington, D.C.*, (1967) 157.
- (6) SPALDING J.F., JOHNSON O.S., ARCHULETA R.F., TIETJEN G.L., *Dose-rate effect on life-shortening in mice*, LA-UR-14-1037 (1974) 1.
- (7) CURTIS H.J., *Stomatic mutations in radiation carcinogenesis. Proceedings of a Symposium on Radiation Induced Cancer*, (1969) IAEA-SM-118/10, 45.
- (8) EATON G.J., OUTZEN H.C., CUSTER R.P., JOHNSON F.H., *Husbandry of the "nude" mouse in conventional and germfree environments*, *Lab. animal Science*, 25 3 (1975) 309.
- (9) SABOLOVIC D., *Lymphocytologie, Thèse de Doctorat d'Etat, Nancy*, (1973) 182p.

#### Remerciements

Ce travail a pu être réalisé grâce à l'assistance technique de Mesdames L'HULLIER et BEAUVALLET pour la partie histologique et celle de Monsieur BLANCHARD pour la partie dosimétrique.

#### Légendes des Figures

1. Survie des souris hétérozygotes 0 mâles, □ femelles, témoins.  
● mâles, ■ femelles, irradiées.
2. Survie des souris nues athymiques 0 témoins - 1 : 2,5 rads/J - 2 : 1,3 rads/J - 3 : 0,9 rads/J.

EVOLUTION AU LONG COURS DE LA REPRISE IMMUNITAIRE  
CHEZ LE RAT IRRADIE A DOSE MOYENNE ET FORTE.

J.L. Malarbot, M. Veyrat, R. Le Gô, J. Prudhomme,  
L. Genest, L. Casteinau.

Département de Protection  
Section de Radiopathologie  
Centre d'Etudes Nucléaires  
Fontenay-aux-Roses - 92260

## 1. INTRODUCTION

Plusieurs populations de lymphocytes intervenant dans les phénomènes immunitaires, et l'irradiation entraînant rapidement une lymphopénie d'importance variable selon la dose, il peut être intéressant de vérifier que les lymphocytes non détruits par l'irradiation, conservent leurs capacités fonctionnelles, l'irradiation n'intervenant alors, que par son effet létal et ne perturbant pas de manière importante les réponses immunologiques. Pour ce faire, des irradiations à différentes doses ont été entreprises et les réactions immunes ont été testées après stimulus antigénique.

## 2. MATERIELS ET METHODES.

### 2.1 Irradiation et immunisation.

Des rats mâles de souche Wistar, pesant environ 300 grammes et âgés de 10 semaines, sont soumis à une irradiation globale homogène au Cobalt 60 à un débit de 25 rads/minute.

L'immunisation est réalisée par injection intrapéritonéale de 1 ml d'hématies de mouton lavées soit 10 milliards de cellules. Elles est pratiquée 1, 2, 3, 4 semaines et 2, 3 mois après irradiation. La réponse immune est observée du 3ème au 6ème jour après immunisation, en utilisant les rates de 5 animaux irradiés et d'autant de témoins.

### 2.2 Préparation des lymphocytes.

Les rates sont prélevées sur les animaux préalablement saignés. Elles sont découpées et broyées finement en eau physiologique. Après élimination des débris tissulaires par centrifugation lente et 2 lavages, un culot cellulaire très riche est obtenu.

### 2.3 Séparation sur gradients de densité.

Un gradient de densité est fait dans un tube à hémolyse par superposition de Ficoll 8%\* et de Contrix 28\*\* à la densité

---

\* Ficoll 400 P.M. 400.000

\*\* Contrix 28 = Sol. 60% de Iotalamate de méthylglucamine.

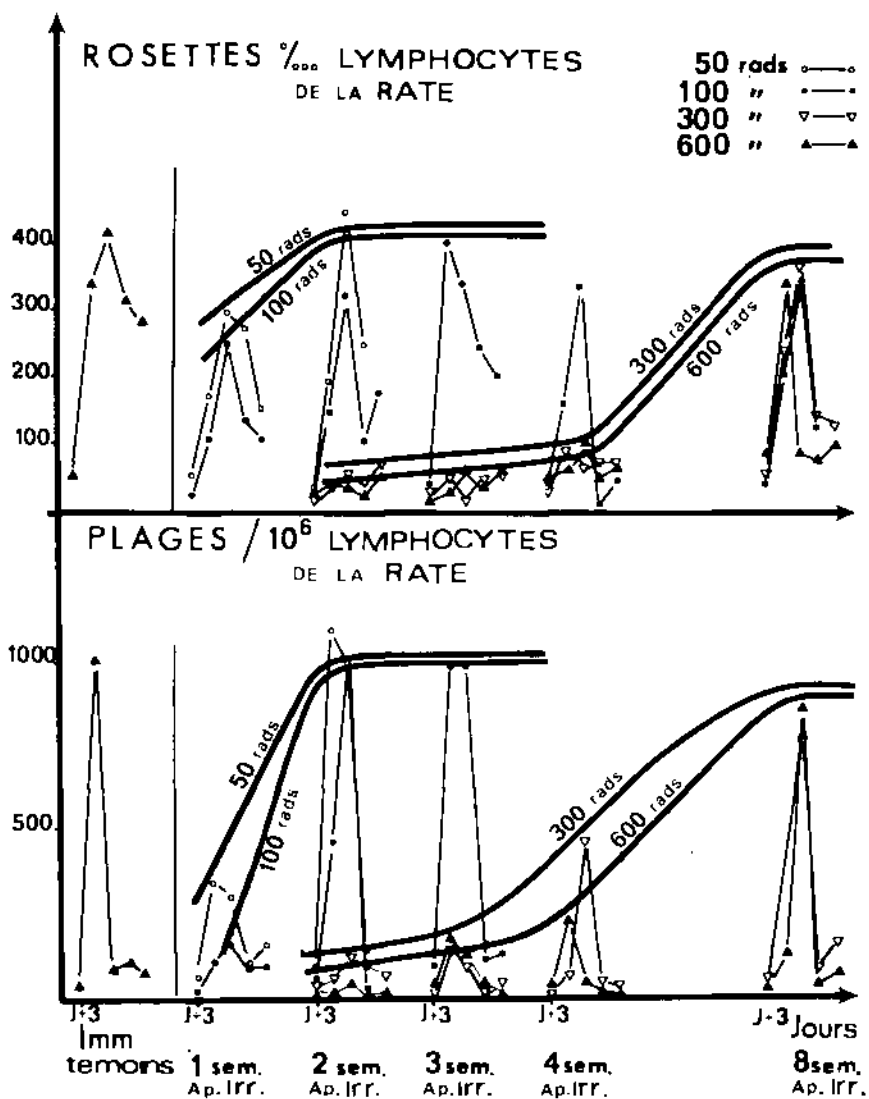

Action de l'irradiation  $\gamma$  à différentes doses sur la réponse immunitaire déclenchée par injection d'érythrocytes de mouton chez le rat, et testée du 3<sup>ème</sup> au 4<sup>ème</sup> jour par la méthode des rosettes immunes et des plages d'hémolyse.

Courbes point par point et interprétation schématique de la réponse à son maximum,

(Imm. 1 sem. ap. irr. - Immunisés 1 semaine après irradiation).

finale de 1.063, 1.071, 1.079, 1.109. Le culot cellulaire, déposé sur le gradient, est centrifugé 20 minutes à 4500 g. Les anneaux obtenus aux interfaces des gradients sont recueillis et lavés 3 fois. Ils sont numérotés de 1 à 4 en partant de la plus faible densité.

#### 2.4 Technique des rosettes immunes.

Les rosettes immunes sont réalisées en mettant en contact 0,2 ml d'hématies de mouton lavées (60.000/ $\mu$ l) et 0,2 ml de lymphocytes (8.000/ $\mu$ l) soit 1 lymphocyte pour 7 hématies. Le mélange est centrifugé à 100g pendant 3 minutes, puis remis en suspension par agitation lente pendant 10 minutes. Le dénombrement des rosettes (un lymphocyte entouré d'au moins 4 hématies) est effectué en cellule de Malassez et rapporté à 10.000 lymphocytes.

#### 2.5 Technique des plages d'hémolyses.

Selon la technique de Jerne, 3ml d'une gélose molle (0,6% d'Agar dans du milieu de Eagle) mélangée à 0,1ml d'hématies de mouton (20%) et à 0,1 ml de lymphocytes, sont coulés sur une gélose dure (1,4% d'Agar) et mis à l'étuve à 38° pendant deux heures, puis recouverts de complément de cobaye au 1/3 durant 30 minutes. Les résultats de la lecture à la loupe binoculaire sont exprimés en nombre de plages par million de lymphocytes.

### 3. RESULTATS.

#### 3.1 Séparation sur gradients de densité.

Différents tests ont été pratiqués sur les cellules des anneaux:

- mesure du volume cellulaire.
- vitesse de migration électrophorétique
- détection des immuno-globulines de surface.

Avec l'augmentation de densité, le volume cellulaire diminue, de même que la vitesse de migration, le pourcentage de cellules à immunoglobulines de surface et de cellules formant des plages d'hémolyse.

Cette séparation entraîne un enrichissement en lymphocytes B des couches légères et en lymphocytes T des couches lourdes. Aussi, nous nous sommes intéressés particulièrement aux anneaux 2 et 4, le 3 ayant des réactions voisines du 4 et l'anneau 1 contenant des débris cellulaires et étant peu fiable.

#### 3.2 Evolution des rosettes immunes et des plages d'hémolyse.

Les rosettes n'apparaissent pas avant le 3ème jour après immunisation, culminent au 4ème ou 5ème jour, pour redescendre rapidement ensuite. Seul, l'anneau 2 sera considéré, les cellules de l'anneau 4 ne formant que très peu de rosettes. La courbe montre que le nombre maximum des rosettes est abaissé même après des irradiations de 50 à 100 rads. Aux doses de 300 et 600 rads, la réponse reste effondrée jusqu'à la 4ème semaine. La restauration de la réponse se fait en 2 semaines à 50 et 100 rads et en 2 mois à 300 et 600 rads.

Avec les plages d'hémolyse, l'évolution est très similaire à celles des rosettes avec, cependant, une dépression plus accentuée la 1ère semaine à 50 et 100 rads.

#### 4. CONCLUSION

L'irradiation entraîne des désordres d'autant plus importants dans la réponse immunitaire que la dose est plus élevée. Ces désordres sont qualitatifs puisqu'une partie des cellules impliquées dans la réponse immune ne peut réagir. Il s'y ajoute un facteur quantitatif pour les fortes doses qui induisent une lymphopénie importante pendant 2 à 3 semaines. Ainsi l'irradiation intervient à la fois sur l'effectif des cellules lymphocytaires et sur la capacité des cellules survivantes à répondre à un stimulus antigénique.

## PROTECTIVE ASPECT OF MITOTIC DIVISION DELAY

V.G. Tyazhelova, I.G. Akoev  
 Institute of Biological Physics, Acad. Sci. USSR,  
 Pushchino, Moscow Region, USSR, 142292

In mammalian cells under small dose irradiation an unspecific complex of reactions develops involving inhibition of DNA synthesis and cell division, decrease of the common level of endogenous thiols and accompanied by an increase in radiosensitivity of the whole organism (1). The high doses of irradiation cause blocking of cell division. The end of the cell delay period in the radiosensitivity system in time coincide with the heightened radioresistance of the organism. For example, the periods of higher resistance to repeated irradiation of mice were observed for haemopoietic death on the 8th - 14th day after irradiation (2,3). This permitted us to discuss the protecting role of cell division delay.

In order to use in practice the cell division delay it is necessary to know its temporal regularities for each stage of the cell cycle. As defined by the analysis of the experimental data on mitotic activity of rodent small intestine epithelium, the block duration increases with the dose. This indicates that the cells need more and more time to restore their structure and function. Each cell cycle stage of the tissue under study has its characteristic limit values of block duration. The revealed regularity is expressed as follows:

$$T_i(D) = t_i + T_{lim_i} (1 - \exp(-A_i D))$$

$$t_1 = T_h, T_{lim_1} = 10 \text{ hs}, A_1 = 0.0034 \quad \text{for stage } G_2,$$

$$t_2 = 5.5 \text{ hs}, T_{lim_2} = 27 \text{ hs}, A_2 = 0.0017 \text{ for stage } S,$$

$$t_3 = 13.5 \text{ hs}, T_{lim_3} = 42 \text{ hs}, A_3 = 0.0012 \text{ for stage } G_1 \quad (4).$$

As for the haemopoietic system, there are no such detailed data on temporal changes in the mitotic index. We can be guided only by the maximal times of depletion of marrow and the data on beginning of restoration of blood leucocyte kinetics (on the 35th day - for humans, on the 20th day - for dogs, on the 12th - 20th day - for rats, on the 8th - 14th day - for mice) (3,5).

By calculation of mitotic activity data we obtained the cell survival curves for different stages of cell cycle and showed that the shoulder on the survival curve is observed as long as the stage becomes longer. As the stage duration reaches its maximum the cells die, this pointing to the protective character of stage elongation (6).

All the aforesaid supports our earlier suggestion that the organism "widely uses" the time factor for a more optimal repair of injury since the rate of repair changes little (7,8). However, the time factor has limitations. It is due to that inhibition



of all vital functions except the repair process cannot last an extended time. Besides, it is known that the prolonged blocking of mitotic division results in depletion of the tissue and in break of its function.

During the mitotic delay the cell system seems to be in isolation from the necessities of the organism because of break of the connections with supernal control levels. This viewpoint is supported by the analysis of biochemical changes in the cell. These changes are directed to repairing the intercellular structure and do not enable the cell to fulfil its function.

At this period the cells lose their glycogen almost completely, the lipase activity decreases appreciably, a sharp drop in the activity of alkaline and acidic phosphatase is observed the succinate dehydrogenase activity reduces to a minimum. At the recovery stage the succinate dehydrogenase activity rises and becomes higher than that in the control. By that time the nucleoli and the nucleous membranes are normalized and most of the mitochondria recover. By the end of mitotic delay the alkaline and acidic phosphatase are highly active which coincides in time with the maximal and supernormal development of agranular reticulum. The intracellular structure is characterized by a great number of free ribosomes and hypertrophy of the Golgi complex producing lysosomes. The development of granular plasmatic reticulum is minimal, its recovery correlates with the start of cell regeneration (8).

The fact that the cell division delay takes place when the organism is affected by ACTH, corticosteroids, radioprotectors also testifies to its protecting role.

Another positive feature of cell division delay was revealed when modelling the recovery process in tissue (9). It was proposed that some quantity of cells repair during the mitotic delay, start to divide thus contributing to cell repopulation. The computations showed that some values of mitotic blocks extend the stability zone of cellular repopulation thus permitting higher values of feedback coefficient to be used. Due to that the initial level of the stationary state is reached with higher accuracy. The stability zone is extended at relatively small blocking time values whereas at great values it sharply narrows. It is found for the white and red blood systems as well as for intestinal epithelium that their experimental values of mitotic block duration extend the stable zone (9).

Thus, inspite of the fact that the cell division delay causes temporal depletion of the functioning tissue it is still positive for the final stage of tissue recovery since it provides higher accuracy of homeostasis.

#### REFERENCES

- (1) KALENDO, G.S. "On possibility of adaptational syndrom-stress on the cellular level and its role in response of the cell to irradiation". *Uspekhy sovremennoi biologii*, 73, NI; 59-80 (1972).
- (2) KOVALEV, V.P., PLOTNIKOVA, F.D., FIDUS, L.Kh. "Study of restoration of mammalian critical systems responsible for different forms of radiation death". *Radiobiologiya*, 11, N 2, 195-200 (1971).

- (3) AKOEV I.G. "Problems of postirradiation recovery". M., Atomizdat (1970)
- (4) TYAZHELOVA, W.G., SAWELYEV, A.P., AKOEV, I.G. "Quantitative analysis of curves of postirradiation mitotic activity as a method for studying the process of intracellular repair" *Studia biophysica*, 42, (1974) 87-98.
- (5) KILLMAN S.A. "Radiation effects on the myelocytic cell renewal system" in Manual on Radiation Haematology, IAEA Vienna, (1971) 89-98.
- (6) TYAZHELOVA V.G. "Theoretical and model description of repair of cell system depending on age of mitotic cycle phase and damage degree", *Studia biophysica*, 46, I (1974) 1-8.
- (7) AKOEV I.G. "Some results of theoretical analysis of radiation injury of organisms" *Izvestiya AN SSSR, N I*, (1976) 41-51.
- (8) TOKIN I.B. "Problems of radiational cytology", Leningrad, "Meditsina" (1974).
- (9) TYAZHELOVA V.G., AKOEV I.G. "Model description of proliferating tissue recovery as a two-level hierarchical system" *Studia biophysica* (in print).

RADIOBIOLOGICAL EFFECTS OF JOINT ACTION OF ALPHA  
RADIATION /Po 210/ AND QUARTZ DUST IN THE RATS  
RESPIRATORY AND RENAL SYSTEM

D. Panov, V. Višnjić, Lj. Novak, M. Kilibarda  
Institute of Occupational and Radiological  
Health, Beograd  
Yugoslavia

## 1. INTRODUCTION

Casarott studied in an extensive study pathohistologic changes in the lungs and kidneys of rats after intratracheal application of Po 210 /1,2/. He found in the lungs a moderate hyperplasia of perivascular and peribronchial lymphatic tissues and in the kidneys serious nephrosclerotic changes after  $10 \mu\text{Ci}/\text{kg}$  Po 210 application. Changes point to early and progressive reduction of cortical blood circulation.

Yuile and coll /3/ studied carcinogenic effect of polonium 210 on the rats lungs. They found increased frequency of lung cancer in relation to the control group of rats. Radford and Hunt /4/, Rajewski and Stahlhofen /5/ and Lorant /6/ point out possibility of polonium 210 influence from tobacco et etiopathogenesis of bronchogenic cancers in smokers. J.B. Little and W.F. O'Toole /7/ found in experimental animals increased frequency of lung cancers after joint application of polonium 210, benzpyrene and hematite. Since workers in uranium mines are exposed to the effect of several factors /alpha activity, radioactive and quartz dust etc/ we intended to establish to which extent these factors have synergistic effect.

## 2. METHODOLOGY

Examination have been done in 30 adult female rats, of "Wistar" race. The animals were divided into four groups of per 20 rats. The first group was subjected to intratracheal application of neutral solution of polonium 210 of  $1 \mu\text{Ci}$  per animal and to 50 ng of quartz dust suspension in saline suspension /dispersion  $1-3 \mu$ /.

The second group received only 50 mg of quartz dust suspension. The third group received only polonium 210 solution of the same activity. The fourth group was the control one.

After 7 months of application the rats were killed. The lungs and kidneys were taken for analysis. The following analyses were done:

Polonium 210 content, collagen content and pathohistologic changes. For polonium 210 determination a method after Black/3/ was used.

### 3. RESULTS OF INVESTIGATIONS

In table 1. polonium 210 content in the rat lungs and kidneys is presented. Results of investigations showed that even 7 months of application a considerable amount of polonium 210 has been found in these organs, i.e. higher concentrations were found in the lungs of the first group /Po 210+SiO<sub>2</sub>/, but in the second they were higher in the kidneys /Po 210/. Results of investigations clearly show that presence of quartz dust in the lungs influences increased polonium 210 retention.

Group	nCi/g ±	standard deviation
	lungs	kidney
Po 210 + SiO <sub>2</sub>	46 ± 15	60 ± 42
Po 210	25 ± 9,5	79 ± 14

Table 1. Polonium 210 concentrations in the rat lungs and kidneys

In table 2. collagen values in the lungs of the rats are given. From statistical analyses of gained values it can be seen that collagen content in the lungs of exposed groups is significantly increased in relation to the control group.

Group	Hydroxyproline	Collagen	t test	P
Po 210 + SiO <sub>2</sub>	4,10±0,35	30,81±2,59	15,63	0,001
SiO <sub>2</sub>	4,42±0,35	33,00±2,57	16,91	0,001
Po 210	1,91±0,17	14,26±1,34	10,90	0,001
Control	0,32±0,10	6,14±0,17	-	

Table 2. Hydroxyproline and collagen content in the rat lungs

It is interesting to emphasize that collagen content in the second group /SiO<sub>2</sub>/ is some what higher /4,42±0,35/ than in the first group /Po 210+SiO<sub>2</sub>/ although pure polonium 210 has fibrogenic effect in the lungs in relation to the control group.

Pathohistologic changes in the lungs and kidneys were very expressive. Because of shortage of space these changes will be given very consisely. Changes pointed out that silicotic process in the rat lungs due to joint application of quartz dust and polonium 210 have in the basis nodular character but with expressed diffuse lung fibrosis.

Malignant alteration in the lungs was considerable more frequent /5 cases at 17 examined rats in the group Po 210+SiO<sub>2</sub>, 1 case at 19 rats in the group who received pure polonium 210, and in the group of rats with pure quartz dust and the control group malignant alterations were not evident./

In the rat kidneys who received polonium 210 glomerulotubular lesions were found. These changes were more expressed in the group of rats who received polonium 210 and SiO<sub>2</sub>. In a smaller number of cases lighter sclerotic changes have been noticed in the kidney interstitium.

## CONCLUSION

Joint action of polonium 210 and quartz dust have been studied in the respiratory and renal system of the rats.

Results of investigations pointed to expressive fibrogenic effect of Po 210 - and SiO<sub>2</sub> in the rat lungs in relation to the control group of the rats, and pathohistologic changes pointed out more frequent malignant alterations in the group of rats who received Po 210 + SiO<sub>2</sub> in relation to the other groups of rats.

Glomerulo-tubular lesions with lighter interstitial sclerosis have been occurred in the kidneys.

REFERENCES:

- 1/ Casarett W.G.  
Pathology of single Intravenous Doses of Polonium  
Radiation Research Supplement 5, 246-321(1964)
- 2/ Casarett W.G.  
Pathology of Multiple Intravenous Doses of Polonium  
Radiation Research supplement 5, 322-346(1964)
- 3/ Yuile C., Berke H, and Hull T.  
Lung Cancer Following Polonium 210 Inhalation in Rats  
Radiation Research 31, 760-774 (1967)
- 4/ Radford P.E., and Hunt R.V.  
Polonium 210 a volatile radioelement in Cigar  
Science, 143, 247-249 (1964)
- 5/ Rajewski B. and Stahlhofen W.  
Polonium 210 activity in the Lungs of Cigarette  
Smokers  
Nature 209, 1312 - 1313 (1966)
- 6/ Lorant H.  
Is polonium 210 the Cancer inducing Factor in excessive  
Cigarette Consumption  
Med. Klin. (Munich) 59, 1106-1107 (1964)
- 7/ John B. Little and William F. O'Toole  
Respiratory Tract Tumors in Hamsters Induced by Benzo (a)  
pyrene and <sup>210</sup>Po - Radiation  
Cancer research 34, 3026-3039, November (1974)
- 8/ Black C.S.  
Low Level Polonium Determination of Tissue and Urine  
The University of Rochester Atomic Energy Project  
UR - 403 New York (1956)

ETUDE AU MOYEN DES SPECTRES CELLULAIRES DE REPARATION  
ERYTHROCYTAIRE ET DU REMODELAGE DES RETICULOCYTES  
APRES IRRADIATION TOTALE.

A. Le Gô, R. Le Gô, J.L. Malarbet, J. Prudhomme, L. Genest.

Département de Protection  
Section de Radiopathologie  
Centre d'Etudes Nucléaires  
92260 Fontenay-aux-Roses.

La réponse érythrocytaire à toute stimulation est faite de cellules de taille très supérieure à la normale. La maturation et la destinée de ces macrocytes ont fait l'objet de nombreux travaux centrés sur deux problèmes : leur durée de vie et leur remodelage en présence ou en l'absence de rate. A la suite des travaux de NEUBERGER et NIVEN en 1951, et sur la base de données isotopiques, la durée de vie des macrocytes est apparue le plus souvent raccourcie, mais de façon variable selon les auteurs. Cependant, plus récemment, les travaux de GANZONI, confirmés par ceux de COME, accordent au remodelage des macrocytes une place plus importante qu'à l'hémolyse totale précoce et soulignent le rôle de la rate dans ce phénomène.

Nous avons, dans un travail antérieur, abordé le problème de la macrocytose radio-induite par l'analyse mathématique des courbes de distribution de volume érythrocytaire (ou spectres érythrocytaires). Nous avons appliqué la même méthodologie à l'étude du remodelage des macroréticulocytes, avec une modification technique, destinée à minimiser l'effet Coulter : la pré-fixation des érythrocytes par le formol.

## 1. MATERIEL ET METHODE.

### 1.1 Spectres érythrocytaires.

La chaîne d'enregistrement comprend un Coulter-Counter couplé à un sélecteur-analyseur d'amplitude (SA 40 d'Intertechnique). Les données numériques, en mémoire dans le sélecteur, sont sorties sur ruban de papier par l'intermédiaire d'une télécopie et sont ainsi directement accessibles au traitement sur ordinateur. Le spectre érythrocytaire normal du rat a un aspect bimodal qui disparaît ou s'atténue fortement après fixation des cellules par le formol neutre à 10% dans du PBS (Figure 1)

### 1.2 Schéma expérimental.

6 rats Sprague Dawley âgés de 2 mois ont été mis en expérience. Une injection de Fe-59 (3 micro Ci de citrate de fer en solution aqueuse par animal) a été faite pour marquer les normoréticulocytes avant irradiation. Quatre jours plus tard, les animaux ont été irradiés aux gamma du Co 60, à la dose sublétales de 725 rads. Le même jour, l'activité sanguine du Fe-59 a été mesurée pour servir de point de référence dans la suite de l'étude.

A partir de la 3<sup>ème</sup> semaine après l'irradiation, et jusqu'à la 11-12<sup>ème</sup> semaine, un contrôle hématologique hebdomadaire a été fait sur le sang recueilli par ponction d'une veine caudale.

### 1.3 Estimation de la production érythrocytaire.

La production "théorique" est basée sur le taux de réticulocytes au jour J, en tenant compte du temps de maturation estimé au préalable "in vitro" sur un échantillon sanguin maintenu à 37°C. Par extrapolation, en supposant une évolution exponentielle de la production, on a calculé la production entre deux jours de prélèvement : production théorique différentielle et par sommation la production théorique cumulée depuis le début de la réparation sanguine.

La production "observée" est basée sur les données du spectre érythrocytaire. En tenant compte de la disparition physiologique basée sur une durée de vie moyenne de 65 jours (expériences préliminaires) et de la disparition par hémorragie, mesurée par l'activité du Fe-59, l'effectif des normocytes restant de J-0 a été estimé et le spectre érythrocytaire correspondant a été construit. En soustrayant ce spectre J-0 pondéré du spectre du jour, est obtenu le spectre de production entre J-0 et J, dont on déduit la production cumulée depuis J-0. La soustraction de deux spectres consécutifs a fourni de même l'estimation de la production différentielle sur une semaine (Figure 2).

## 2. RESULTATS.

### 2.1 Evolution hématologique après irradiation.

L'anémie est maximum entre J-21 et J-28. Après une phase de réparation rapide, jusqu'au 42ème jour, suit une phase de réparation plus lente.

La réticulocytémie. On observe 2 vagues de réticulocytose :  
- la première, entre J-21 et J-42, correspond à la phase de réparation rapide avec production de macroréticulocytes.  
- la deuxième, au-delà de J-42, correspond à la production de normoréticulocytes.

Le volume globulaire moyen subit un accroissement important entre J-21 et J-35, suivi d'une réduction de  $12.2 \pm 4.8$  microns entre J-35 et J-56.

### 2.2 Evolution des spectres de production différentielle.

(c'est à dire de la production hebdomadaire entre deux prélèvements successifs).

La Figure 3 montre que la macrocytose est maximale dans les premiers jours de la réparation sanguine, avec un VGM double de la normale. Puis intervient une réduction de taille qui progresse régulièrement vers la normalisation obtenue vers J-70. Tous les spectres, à partir de J-42, ont un aspect biphasique avec : une onde positive qui correspond à l'apparition de nouvelles cellules et une onde négative qui correspond à une disparition cellulaire. Cette onde négative se situe toujours dans la zone des plus grands volumes et indique que les cellules de plus grande taille disparaissent et ne sont pas remplacées par des cellules de taille équivalente. Il faut remarquer à ce propos, que la disparition de macrocytes peut relever de 2 mécanismes : soit la destruction totale, soit le remodelage qui les fait passer dans une classe de volumes inférieurs. Dans ce cas, les macrocytes remodelés viennent se classer dans l'onde positive, qui fournira alors une surestimation de la production réelle dans la période considérée.

Ceci est très important dans l'interprétation des résultats ultérieurs.



2.3 Comparaison entre "production théorique" et "production observée". Elle est illustrée par la Figure 4. Production cumulée (courbes supérieures): en dépit de l'approximation des calculs, les deux estimations concordent bien jusqu'à J-56. Puis la production observée est inférieure à la production théorique; il faut souligner que cette dernière ne tient pas compte de la mortalité cellulaire, alors que le spectre normalisé sur la numération du jour, est affecté par celle-ci. Il est donc très vraisemblable que la divergence entre les deux estimations à partir de J-56 est due à la mort prématurée des macrocytes aux environs du 42ème jour, soit les 2/3 de la normale (MILETTE ou CARD). Production différentielle: il existe à J-42 et à J-56, une différence importante entre les deux types d'estimation au profit de l'estimation sur spectre. Le remodelage des macrocytes aboutissant à une surestimation de la production sur spectre, il semble que ce soit là l'explication de cette divergence, puisque dans le même temps les productions cumulées théorique et observée concordent assez étroitement. Cette explication est d'autant plus tentante que le VGM subit parallèlement une décroissance assez brusque.

#### CONCLUSION.

Les spectres érythrocytaires permettent de suivre l'évolution spontanée de la réparation post-anémique, en évitant les inconvénients inhérents aux manipulations et aux transfusions de cellules marquées.

Les résultats obtenus semblent indiquer que les macrocytes de réparation subissent des phénomènes de remodelage, mais quelle que soit l'importance de ce remodelage, la durée de vie de ces macrocytes paraît raccourcie. Ces résultats concilient donc les différentes hypothèses avancées sur la maturation et la cinétique des macrocytes de réparation.

#### REFERENCES.

- NEUBERGER A., NIVEN J.S.F - Haemoglobin formation in rabbits (J. Physical - London 1951, 112 : 292 - 310).
- GANZONI A., HILLMAN R.S, FINCH C.A.- Maturation of the macroreticulocyte (Brit. J. Haematol. 1969, 16 : 119).
- CARD R.T, VALBERG L.J., - Characteristics of shortened survival of stress reticulocytes. (Am. J. Physiol 1967, 213 : 560).
- MILLETTE R.L., GLOWACKI - In vivo maturation of reticulocytes transfused into a normal rabbit (Nature - 1964, 204 : 1207 - 1209).
- LE GO A., LE GO R., MALARBET J.L., PRUDHOMME J.- Intérêt pratique des spectres érythrocytaires au cours des états de réparation post-anémique. (Nouv. Rev. Fr. Hématol. 1972, 12 139 - 158).

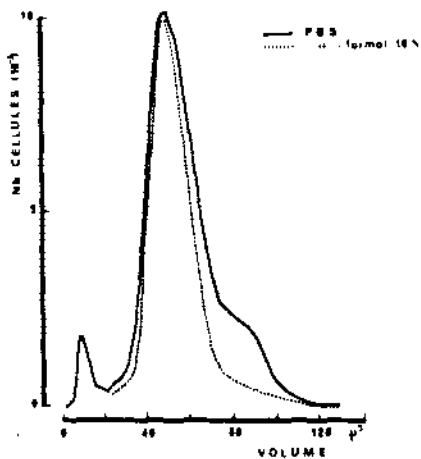

**Fig. 1** Atténuation de l'effet Coulter par préfixation des érythrocytes en PBS-Formol 10%

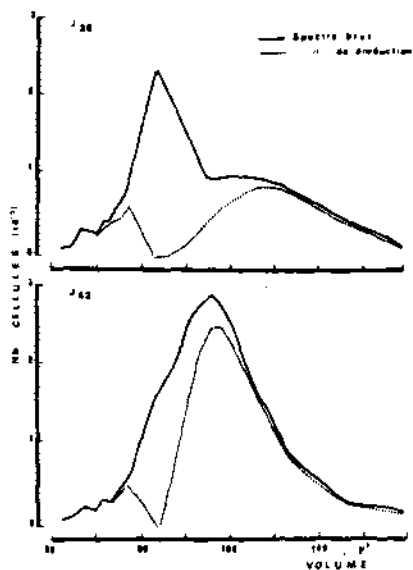

**Fig. 2** Spectres de "production" entre J0 et J1 (=spectre brut défilé des normocytes présents avant irradiation).

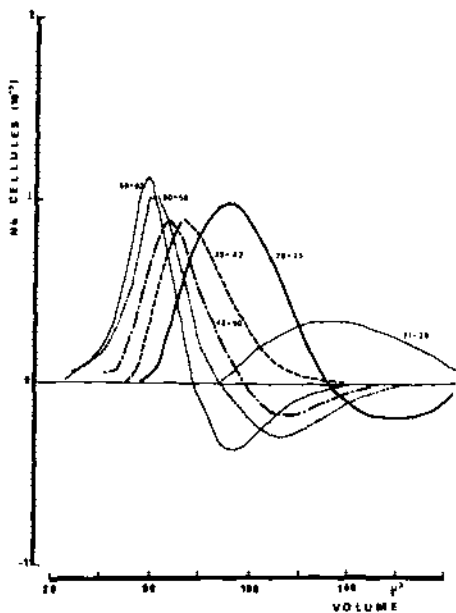

**Fig. 3** Spectres de la production entre 2 jours de prélèvement (notés en regard des courbes) traduisant l'apparition (ou de positive) et la disparition (ou de négative) de cellules d'un volume donné.

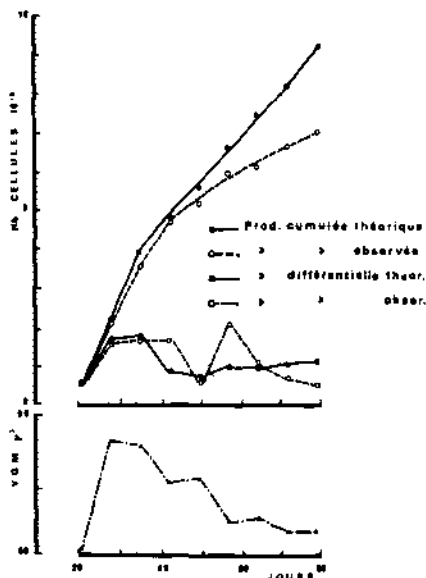

**Fig. 4** Comparaison entre "production théorique" (estimé par réticulocytémie) et production observée (estimé sur spectres) rapportées à l'évolution du VGM.

ESSAIS DE TRAITEMENT DES IRRADIATIONS ABDOMINALES  
AIGUES CHEZ LE PORC.

F. DABURON

Laboratoire de Radiobiologie Appliquée - C.N.R.Z. -  
78350 JOUY -en-JOSAS (Section de Radiopathologie -  
Département de Protection -Centre d'Etudes Nucléaires de  
FONTENAY -aux-ROSES 92260 FONTENAY -aux-ROSES.

1 - INTRODUCTION.

Peu de recherches ont été entreprises sur un éventuel traitement des irradiations abdominales aiguës et à des doses susceptibles d'entraîner un syndrome gastro-intestinal. Le porc semble un bon modèle expérimental, dans l'optique d'une extrapolation à l'Homme, à cause notamment :

- de l'anatomie du tube digestif (disposition et volumes respectifs des différents segments).
- de la physiologie digestive (animal omnivore - les taux d'enzymes des cellules de l'épithélium intestinal sont comparables (2)).
- du taux de renouvellement de l'épithélium intestinal (4,5 - 5,5 jour contre 5 à 6)(4).
- de son volume corporel qui permet des comparaisons étroites en ce qui concerne la dosimétrie radiologique.
- de la possibilité d'expérimenter en simulation hospitalière avec une alimentation parentérale continue (cathéter jugulaire à demeure) et alimentation entérale continue (sonde stomacale à demeure).

2 - METHODOLOGIE

- Animaux : PITMAN MOORE adultes pesant entre 35 et 65 kg.

- Conditions d'irradiation (3) : L'installation comprend 8 sources de  $^{60}\text{Co}$  de 800 Ci chacune. L'animal est placé éveillé dans un hamac; 2 plaques de plomb de 7,5 cm d'épaisseur protègent sa partie antérieure à partir d'un plan transverse passant par l'appendice xyphoïde, permettant ainsi la survie de 10% de la moelle osseuse après 800 rads et 5% après 1250 rads(3). Le débit de dose moyen de 80 r/min. et la dose absorbée au plan médian des animaux de 40 rads/min. en moyenne. Les doses absorbées ont varié de 800 à 1700 rads.

- Traitement - Réanimation

<u>Dose</u>	<u>Régime</u>	<u>Traitement</u>	<u>Observations</u>
800 rd.	Diète hydrique	Antibiotiques généraux	0 -10 jours
950 rd.	-id -	- + perfusions légères.	si hyperthermie. si anorexie prolongée
1000rd.	2 litres d'eau/j. par fraction de 100 ml	Alimentation parentérale continue <sup>x</sup> Antibiotiques	10 jours si hyperthermie.
1100- 1175-1250 rd.	-id-	Alimentation parentérale continue <sup>x</sup>  -continue <sup>xx</sup> - + antibiothérapie générale Pansements gastrointestinaux et antibiothérapie locale Alimentation entérale continue <sup>xxx</sup>	1er au 5 ème jour.  6 ème au 18 ème jour 2ème au 12 ème jour 2 ème au 15 ème jour  15ème au 21ème jour
1350-1700 rd.	-id -	Alimentation parentérale continue Antibiothérapie générale Pansements gastrointestinaux et antibiothérapie locale	10-15 jours selon survie

Pour un porc de 50 kg et par jour :

x vol. 1750 ml - 1200 cal.	4 g N	(Na 63 meq-K 41 meq-Ca 151 meq- P 405 meq.                 )
xx vol. 1750 ml - 1700 cal.	10 g N	
xxx vol. 2500 ml - 2300 cal		aligoholosides - acides gras à chaine moyenne -protéines du lait - pectine - minéraux -vitamines.

- Greffes d'intestin : 6 animaux irradiés à 1250 rads ont subi une greffe d'intestin (jéjunum + iléon) à partir d'un frère compatible pour le système majeur SL A, 4 heures après exposition ; pour 7 autres porcs la greffe a été réalisée après 13- 21 jours d'alimentation parentérale. Après les greffes, les deux groupes d'animaux ont reçu une réanimation parentérale respectivement de 15 jours et 10 jours.

### 3 - RESULTATS

#### a) Cinétique de la restauration intestinale (2).

Aspect qualitatif des lésions

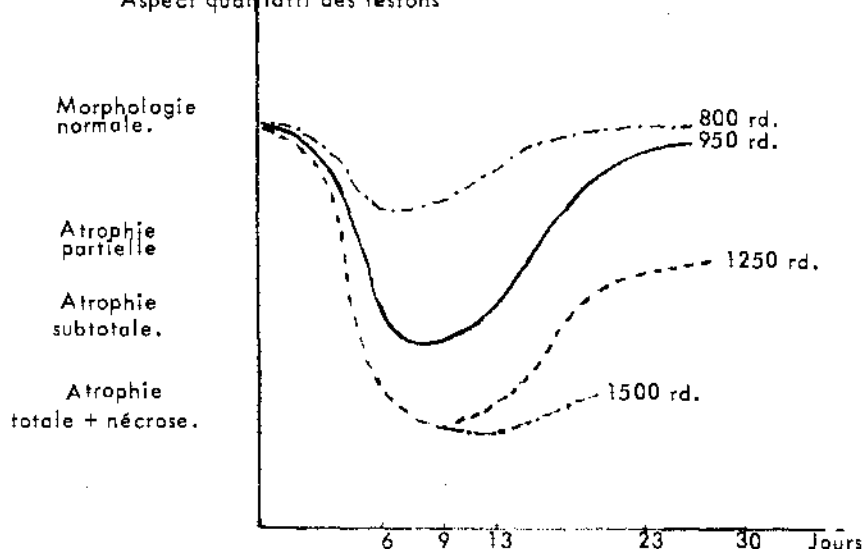

#### b) Survie en fonction des doses et des traitements.

Dose	SURVIE EN JOURS		Nombre d'animaux	OBSERVATIONS
	Voieurs limites	médiane		
800 rads	Survie prolongée (>1 an)		8	6 animaux survivants plus de 100 jours ont été sacrifiés pour convenance.
950 rads	7 - 367	66	14	- id -
1000 rads	7 - 200	120	10	morts naturelles
1100-1250 rads	45-200	75	6	- id -
1250 rads	7 - 36	24	8	Pas d'alimentation entérale(1) continue.
1350-1500 rads	7 - 20	14	4	- id -
1600-1700 rads	6 - 8	7	4	Sujets non traités.
1690-1700 rads	8 -16	10	4	Sujets traités.
1250 rads	3-25	10	6	Greffe d'intestin précoce(1)
1100 rads	16-46	25	7	Greffe d'intestin retardée (13 à 21 jours)
	(3 -30 opès greffe)			
Témoins	3 -360	21	35	Greffe d'intestin sans immunosuppression(5).

## DISCUSSION

La dose limite d'irradiation abdominale chez le porc, compatible avec une longue survie ( $> 1$  an) est proche de 1000 rads. Après 1100 rads on peut atteindre 200 jours et après 1175 un peu plus de 70 jours. Macroscopiquement on ne note pas pour ces doses de lésions intestinales importantes, bien qu'on décèle microscopiquement une atrophie partielle accompagnée le plus souvent d'une entérite exsudative. Au delà de 1250 rads, la survie ne dépasse pas 1 mois et les lésions intestinales sont intenses (atrophie subtotale et même totale, inflammations, ulcérations, infarctissements). Si la cause de la mort apparaît nettement liée aux atteintes intestinales après 1250 rads, il n'en est pas de même après 1100-1175 rads ; mais pour ces dernières doses et si la survie des sujets est suffisamment longue on voit à l'autopsie une atrophie pancréatique intense et une atrophie rénale bilatérale (en 6 mois le poids des 2 reins baisse de 40%). Cette sclérose rénale ne semble pas retentir de façon dramatique sur les animaux, tout au moins du point de vue du volume d'urine et des taux sanguins d'urée et de créatinine. Par contre, l'atrophie pancréatique est vraisemblablement responsable des problèmes de maldigestion et de malnutrition conduisant les sujets à une anorexie définitive : les porcs perdent 20% de leur poids dans les 10 -15 jours qui précèdent leur mort.

Enfin la greffe d'intestin, si elle est bien supportée du point de vue opératoire par des individus irradiés à forte dose, ne paraît pas avoir d'influence bénéfique sur la survie.

## CONCLUSION

On ne peut donc espérer faire vivre plus de quelques mois des porcs irradiés sur l'abdomen à des doses dépassant 1100 rads ; si l'intestin paraît capable de récupérer une certaine capacité fonctionnelle malgré l'installation d'une atrophie définitive, les radiolésions rénales et surtout pancréatiques semblent être les facteurs critiques de la survie.

## BIBLIOGRAPHIE

- 1- F. DABURON, G. CHOMETTE, H. GARNIER, J. REMY, P. A. VILLIERS, P. NIZZA.  
Strahlentherapie 146, (6), 1973, 718 -733.
- 2- F. DABURON, G. CHOMETTE, J. REMY, P. A. VILLIERS, J. C. GREGOND, Y. TRICAUD, M. SEVIGNAC et J. HAAG.  
Biol. Gastroenterol. (Paris) 1975, 8, 321 -338.
- 3- J. MAAS, M. VAIMAN, H. GAILLARD, P. NIZZA, C. CHENUT  
Strahlentherapie, 144 (4), 1972, 457-476.
- 4 - J. C. MESLIN, F. DABURON  
A paraître .Annales de Biologie Animale, Biochimie, Biophysique, 1977.
- 5 - M. VAIMAN, H. GARNIER, A. KUNLIN, J. M. HAY, R. PARC, F. BACOUR, P. H. FAGNIEZ, P. A. VILLIERS, J. LECOINTRE, Marie-Françoise BARA et P. NIZZA.  
Transplantation, 14 (5), 1972, 541 -550.

DECORPORATION OF  $^{241}\text{Am}$  AND  $^{252}\text{Cf}$  BY Ca-DTPA FROM RAT, SYRIAN AND  
CHINESE HAMSTER

A. Seidel

Kernforschungszentrum Karlsruhe, Institut für Strahlenbiologie,  
7500 Karlsruhe, Postfach 3640, Federal Republic of Germany

## 1. INTRODUCTION

Considerable differences have been observed between animal species with regard to the retention of transuranium elements in the liver: They are retained with a very long biological half-life by Syrian and Chinese hamster (1), dog and man, whereas in rats, the most widely used laboratory animal for decorporation studies, an exceptionally rapid natural excretion from the liver takes place (references see 2) together with a very good mobilization of radionuclides by chelating agents. Our study deals with the question of the degree at which the results obtained with rats can be extrapolated to other animal species. In this respect, only few data exist (e.g. 3).

## 2. METHODS

Animals were 12 - 15 weeks old female rats (Heiligenberg strain, 175 - 205 g), Syrian hamsters (80 - 105 g) and Chinese hamsters (25 - 30 g). They were injected intraperitoneally with monomeric  $^{241}\text{Am}$ - or  $^{252}\text{Cf}$ -citrate. A single intraperitoneal injection of Ca-DTPA (diethylenetriaminopentaacetate) was administered 24 hours after the radionuclides; the chelate dosage is indicated in Table 1 and Figure 1. These animals were sacrificed 8 days after radionuclide administration. Repeated Ca-DTPA injections ( $30 \mu\text{mol}\cdot\text{kg}^{-1}$  intraperitoneally) were given on the 4., 11., 16..... 81. day after  $^{252}\text{Cf}$  injection and the animals were sacrificed on the 88. day. The radionuclides in the organs were assayed by liquid scintillation counting (4) and calculation of skeleton radioactivity by multiplying by 20, 23 and 34 the radioactivity in one femur of rats, Syrian and Chinese hamsters, respectively (5).

## 3. RESULTS

Deposition of  $^{241}\text{Am}$  and  $^{252}\text{Cf}$  in control animals on the 8. day and of  $^{252}\text{Cf}$  on the 98. day can be seen in Tables 1 and 2; for comparison, deposition of  $^{241}\text{Am}$  has also been determined in control animals on the 71. day: In skeleton, it amounts to 18, 30 and 19 % of the dose and in the liver to 2, 27 and 39 % for rats, Syrian and Chinese hamsters, respectively. Both radionuclides are retained in the skeleton with a long biological half-life with only minor differences between animal species, whereas in the liver the species differences already mentioned can be seen.

With few exceptions, more  $^{252}\text{Cf}$  than  $^{241}\text{Am}$  can be mobilized by DTPA (Table 1). The removal of both radionuclides from the skeleton is somewhat lower in Chinese hamster as compared to rats and Syrian hamsters. In the liver, the DTPA effectiveness is virtually the same for rats and Chinese hamsters but lower for Syrian hamsters (Table 1), though both hamster species behave similarly as far as radionuclide retention is concerned. The more detailed study of the dose effect

Species	Radio-nuclide	Chelate dose (umol·kg <sup>-1</sup> )	Skeleton	n	Liver	n
Rat	241Am	0	22.5 ± 1.1	7	40.4 ± 2.0	7
		30	18.0 ± 0.6 (80)	8	22.8 ± 3.5 (56)	8
		1000	22.8 ± 0.9 14.3 ± 0.7 (63)	7 7	35.3 ± 0.8 3.8 ± 0.3 (11)	7 6
	252Cf	0	43.5 ± 0.9	11	11.1 ± 0.5	11
		30	30.2 ± 0.8 (69)	4	3.7 ± 0.2 (33)	4
		1000	25.9 ± 0.6 (60)	6	1.7 ± 0.1 (15)	6
Syrian hamster	241Am	0	32.4 ± 1.1	5	34.4 ± 1.2	6
		30	23.4 ± 1.0 (72)	8	24.7 ± 2.2 (72)	8
		1000	26.6 ± 1.1 19.9 ± 1.2 (75)	8 8	33.2 ± 2.2 12.0 ± 2.2 (36)	7 6
	252Cf	0	39.5 ± 1.2	9	9.8 ± 0.4	9
		30	27.4 ± 3.1 (59)	6	5.5 ± 0.7 (56)	6
		1000	23.7 ± 1.1 (60)	10	2.8 ± 0.6 (29)	10
Chinese hamster	241Am	0	26.2 ± 1.2	6	38.4 ± 1.7	6
		30	24.5 ± 1.7 (94)	7	19.3 ± 1.3 (50)	7
		1000	20.6 ± 2.0 15.8 ± 1.3 (77)	5 6	35.0 ± 3.6 5.8 ± 1.1 (16)	5 6
	252Cf	0	29.1 ± 0.7	5	11.4 ± 1.5	5
		30	24.0 ± 1.1 (82)	6	3.9 ± 0.2 (34)	5
		1000	19.0 ± 0.03 (65)	6	1.7 ± 0.1 (15)	6

TABLE 1 Removal of 241Am and 252Cf from rodents by Ca-DTPA, injected 24 hours after radionuclides. Values in % of radionuclide dose, those in brackets represent % of control. Arithmetic means ± S.E.; n = number of animals per group, sacrificed 8 days after radionuclide injection.



Species	Skeleton		Liver	
	0.9 % NaCl	Ca-DTPA	0.9 % NaCl	Ca-DTPA
Rat	41.1 ± 1.3	20.9 ± 0.6 (51)	1.89±0.13	0.36±0.03 (19)
Syrian hamster	40.7 ± 1.7	23.7 ± 0.6 (58)	7.70±0.97	2.28±0.35 (30)
Chinese hamster	31.1 ± 0.9	16.4 ± 0.8 (53)	12.54±0.94	0.66±0.09 (5)

TABLE 2 Removal of  $^{252}\text{Cf}$  from rodents by 12 Ca-DTPA doses (30  $\mu\text{mol}\cdot\text{kg}^{-1}$  on the 4., 11....8<sup>th</sup>. day). Values in % of radionuclide dose, those in brackets represent % of control. Arithmetic means  $\pm$  S.E., 5 - 8 animals per group, sacrificed 35 days after  $^{252}\text{Cf}$  injection.

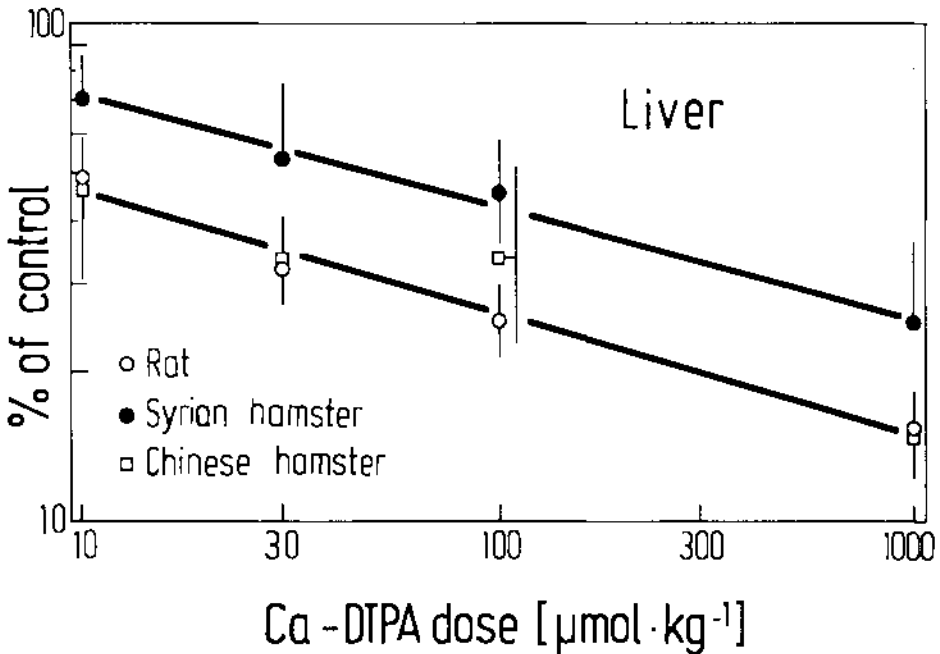

FIG. 1 Removal of  $^{252}\text{Cf}$  from rodent liver by Ca-DTPA, injected 24 hours after  $^{252}\text{Cf}$ . Geometric means with fiducial limits ( $P = 0.05$ ), on the average 7 animals per group, sacrificed 8 days after  $^{252}\text{Cf}$ .

function for the removal of  $^{252}\text{Cf}$  confirms (Figure 1) that the response of rat and Chinese hamster liver is identical, whereas about ten times more DTPA must be administered in order to remove the same fraction of  $^{252}\text{Cf}$  from Syrian hamster liver. It should be noted that in all species the dose effect functions are linear on the double-logarithmic scale and that their slopes are identical. There are only negligible species differences with regard to the removal of  $^{252}\text{Cf}$  from skeleton by chronic DTPA administration (Table 2). However, the mobilization of  $^{252}\text{Cf}$  from Chinese hamster liver is even higher than from rat liver.

#### 4. DISCUSSION

Our data indicate that results of decorporation studies with rats can also be valid for other animal species. This holds for the skeleton and, which is surprising, also for the liver. In spite of the considerable differences between the rat and Chinese hamster with regard to the biological half-life of  $^{241}\text{Am}$  and  $^{252}\text{Cf}$  in the liver, the effectiveness of a single DTPA administration is the same in both animal species. As far as the dose effect function for the removal of  $^{252}\text{Cf}$  from Syrian hamster liver is concerned, it is at least linear to that for rats and parallel to the latter on a double logarithmic scale. It might have been expected that radionuclide mobilization is especially easy from an organ with a rapid natural radionuclide excretion like rat liver; the results after chronic DTPA administration show, however, that the  $^{252}\text{Cf}$  fraction, which can be mobilized from Chinese hamster liver is even higher than that from rat liver. Obviously, the assumption of an inverse proportionality between the biological half-life of a radionuclide in an organ and the degree of its mobilization by DTPA cannot be generalized. Almost complete removal of  $^{241}\text{Am}$  by chronic DTPA administration has also been achieved from dog liver (3). Since the liver is one of the critical organs after incorporation of actinides, these and our findings support the usefulness of chronic DTPA treatment.

#### REFERENCES

- (1) BROOKS, A.L., MEAD, D.K., PETERS, R.F., Lovelace Foundation Report LF-45 p. 240, Albuquerque (1973)
- (2) ICRP Publication Nr. 19, Pergamon Press, Oxford (1972)
- (3) LLCYD, R.D., McFARLAND, S.S., TAYLOR, G.N., WILLIAMS, J.L., MAYS, C.W., Radiat. Res. 62 (1975) 97
- (4) SEIDEL, A., VOLF, V., Int. J. Appl. Radiat. Isotopes 23 (1972) 1
- (5) SEIDEL, A., submitted for publication in Health. Phys.

## MEDICAL MODIFICATION OF HUMAN ACUTE RADIATION INJURY

Niel Wald, M.D. and Joseph A. Watson, Ph.D.  
Graduate School of Public Health, University of Pittsburgh,  
Pittsburgh, Pa., U.S.A.

In weighing the benefits and risks of utilizing nuclear energy, there must be a continuing reassessment as nuclear technology develops and changes. The health effects of radiation accidents, a most important part of the risk, must also be reevaluated as our medical ability grows to modify and ameliorate the consequences.

As part of a recent reactor safety study (1), we reviewed the pertinent human experience (including atomic bomb victims, radiation accident cases and radiation therapy cases) associated with useable exposure, effect and treatment information. Some large animal experimental data were used where important gaps in information required it.

The acute somatic effects of human exposure to ionizing radiation occur in a relationship to the magnitude of exposure which is non-linear. That is, the responses which can be recognized as manifestations of clinical injury do not appear unless the absorbed radiation dose is above a certain level. Beyond that level a variety of malfunctions become apparent, the most characteristic of which will be described below. This apparent "threshold" is a result of the end point chosen, i.e., clinically manifest injury, and does not mean that damage detectable by other criteria has not occurred at lower levels of exposure.

When man is exposed to a large single short-term (seconds to a few hours) whole body exposure to ionizing radiation, the resultant injury is expressed as a complex of clinical symptoms, signs and laboratory findings which are collectively termed the acute radiation syndrome. The exposure is almost invariably to external penetrating radiation. Accidental external and/or internal radionuclide contamination alone does not usually occur at high enough radiation levels for a long enough time to produce this kind of clinically apparent response. Acute clinical effects of a combination of external penetrating exposure with radionuclide contamination have been seen in one nuclear weapons test and in a few industrial "criticality" accidents in reactor research and fuel processing operations.

#### Dose-Mortality Curves for Whole Body Short Term Exposure

The production of nuclear weapons during World War II was the major stimulus for the development of quantitative information about the mortality to be expected in humans exposed to brief bursts of high dose radiation. Both information concerning the effects of various forms of radiation therapy on patients and the results of the growing body of animal experimentation were utilized for this purpose. Subsequently information became available concerning radiation effects on otherwise normal individuals from the Hiroshima and Nagasaki populations exposed to nuclear weapons in 1945 and relatively small number of individuals involved in radiation accidents in the growing nuclear industry.

General agreement developed that the most useful single piece of radiobiological information was the quantity of radiation exposure which would be lethal to 50% of an untreated human population within 60 days. This information was generally extrapolated from animal dose-response experiments and some human data as it became available. There was a general consensus that the LD<sub>50/60</sub> was 450 R, as reported by Warren and Bowers in 1950 (2). (This corresponds roughly to 300 rads midline absorbed dose). Both the

concept and the quantitative data have undergone many refinements and reevaluations since that time. Since direct experimental information on normal humans cannot be obtained for ethical reasons, the subject remains incompletely resolved, with continuing attempts to infer the most likely answers from new data made available by radiation accident or therapy cases. This paper represents one such attempt.

Over the years there have been several definitive reviews of the subject such as that of UNSCEAR in 1962 (3) and NCRP Committee 42 in 1974 (4). The advent of human space travel led to a new effort at risk assessment for crew members who might inadvertently encounter radiation exposure from solar storms. This was evaluated by a National Academy of Sciences space radiation study panel chaired by Langham (5), and more recently reviewed by Lushbaugh (6).

Two newer studies of radiation therapy patients have also been used in arriving at human dose-response information for lethality. These are the leukemia patients treated by Thomas et al at the University of Washington, Seattle (7), and the Ewing's sarcoma patients given radiation therapy by Rider and colleagues at the Ontario Cancer Institute, Princess Margaret Hospital in Toronto (8).

In the analysis of the lethality data it was considered that a dose-response relationship based on the absence of any treatment would be somewhat unrealistic and less than useful in evaluating the health hazards of radiation accidents. For this reason dose-response relationships were developed for three levels of treatment: minimal, supportive and heroic.

"Supportive" treatment has been used to indicate inclusion of "reverse" isolation (measures to protect patient from pathogenic bacteria and viruses in his environment, such as the use of sterile garments and masks by entering personnel, sterilization of all objects in patient's room, use of portable or permanent laminar air-flow systems, etc.), copious antibiotics and transfusions of whole blood packed cells, or platelets. "Minimal" therapy was used to indicate the absence of any of these measures. "Heroic" therapy was used to indicate extraordinary procedures such as bone marrow transplantation or lung lavage.

The mortality curves shown in Figure 1 are drawn from the fortunately limited amount of pertinent human experience. The  $LD_{50/60}$  doses for the three levels of treatment are 340, 510 and 1050 rads, respectively. The curves developed for these three levels of clinical management obviously are not based on large numbers of cases studied under ideal conditions. Rather, they are the best interpretations we can make of the various clues obtained from the available human data. The reasoning for the specific features of each curve are given below.

Curve A ("Minimal" treatment): It is considered that lethality might occur in rare instances beginning at about 150 rads, in spite of the absence of any fatalities in the Marshall Islanders (9) who supply the first actual data point at about 175 rads. This conservative approach was based on the recognition that the exposure in the Marshallese was protracted to approximately 50 hours which may have ameliorated some of its effects. The selection of 250 rads as an  $LD_{10}$  is based largely on the clinical observations in Rider's series of Ewing's sarcoma patients (8). In the absence of the supportive therapy that they received, it appeared likely that several more fatalities would have occurred and therefore, that somewhat lower exposures would also be lethal to some. When  $LD_{10}$  and  $LD_{100}$  points were connected to form Curve A, an  $LD_{50}$  or 340 rads resulted. Accepting the uncertainty of  $\pm 10\%$  suggested by NCRP Report 42 (4), this provides a range of 314-374 rads, which overlaps the best estimate figure of the Biomedical

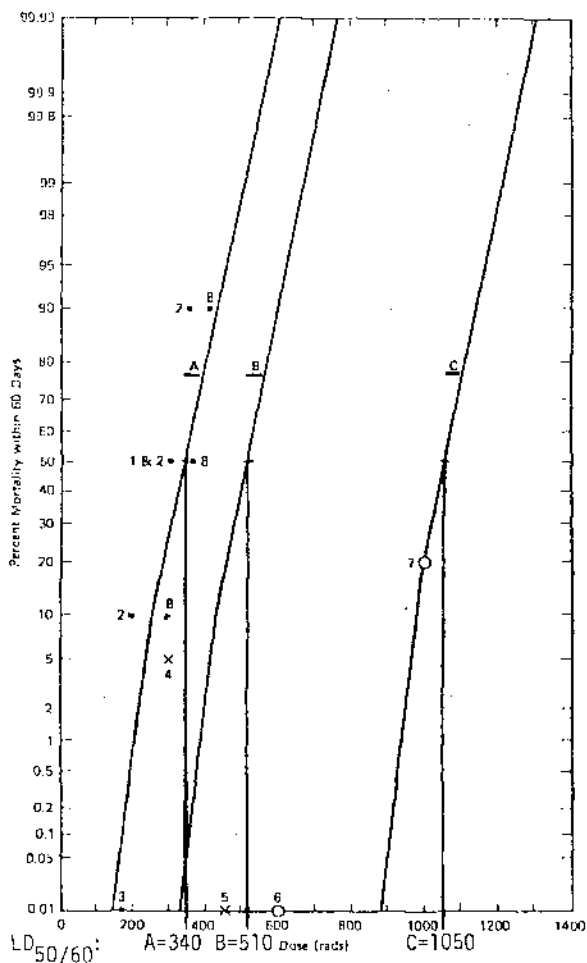

Figure 1

Estimated dose response curves which provide the basis for predicting the exposure levels that would produce 50% mortality in 60 days with minimal treatment (curve A), supportive treatment (curve B), and heroic treatment (curve C). Origin of data points: 1: NCRP Report 42 (4) (converted to rads using factor given in report); 2: Langham (5) (Table 12, estimate for "normal man?"); 3: Marshall Islanders (9) (protracted exposure); 4: radiation therapy series, 22 patients (8); 5: clinical group III accident patients (12) (with newer cases added); 6: Pittsburgh accelerator accident patient (13,14); 7: 37 leukemia patients (7); 8: "best estimate" of the Biomedical and Environmental Assessment Group, BNL (10).

and Environmental Assessment group at Brookhaven National Laboratory (10) and the UNSCEAR Report of 1962 (3) at 360 rad, and is close to the 300 rad suggested in NCRP Report 42 (4) and NAS document 1487 (5). In addition, it provides a span of 230 rads from LD<sub>50</sub> to LD<sub>95</sub> which is in fairly close agreement with the span of about 200 rads found experimentally in dogs (11) and other animals. Finally, it is in keeping with the analysis of statistical features of radiation injury in NCRP Report 42 (4) which suggests that the LD<sub>5</sub> in large animals and man is about half the LD<sub>50</sub>.

Curve B ("Supportive" treatment): Assumptions used in the development of this curve included that the shape would be likely to be approximately the same as Curve A and that the effect of therapy in the experimental dog studies cited above suggest that a factor of approximately 1.5 increase in the LD<sub>50</sub> exposure is obtainable by supportive therapy. In addition, evaluation of Rider's patients (8) (data point 4) showed only one fatality in the post-irradiation period in 22 cases, and that was related to an accidental fall complicated by radiation effects. Another supportive therapy data point, (data point 5) was located on the basis of the lack of mortality in Group III accident patients (12) having a mean exposure of at least 450 rads but less than 600 (4). Curve B gave an LD<sub>50/60</sub> of 510 rads.

Curve C ("Heroic" treatment): The same curve shape was used for Curve C as in the preceding ones. The main data points were the 600 rad Pittsburgh accelerator accident patient (data point 6) who survived following syngeneic bone marrow transplantation (13,14) and the therapy series of Thomas, et al. (7) (data point 7) which showed a post-irradiation period mortality of only 20% in the 37 leukemic patients treated with 1000 rads of whole body irradiation followed by allogeneic bone marrow transplantation in the past two years. The severe illness which justified this form of therapy suggests that the latter data point is conservative for normal individuals. An LD<sub>50/60</sub> of 1050 rads was derived from Curve C.

### Specific Organ Involvement

Because of the possibility of external exposure to part but not all of the body, or the inhalation or ingestion of radionuclide contamination, the potential for fatal effects of localized radiation injury of certain key organs requires some consideration. The bone marrow, lungs and gastrointestinal tract are organs of particular importance.

Bone Marrow: Damage to the bone marrow is, of course, the predominating event in the production of the hematologic form of the acute radiation syndrome. The sequence of events has been reviewed in detail in many publications (15-17).

When bone marrow damage is produced by external sources of irradiation, the lymphoid tissue is also severely damaged, resulting in a further enhancement of the reduction of defenses against infection. Also, the vascular system is damaged under such circumstances, enhancing the hazard of bleeding. In the event of bone marrow irradiation by the incorporation of radioactive isotopes of elements with predilection for the bone or marrow cells, e.g. <sup>90</sup>Sr, <sup>198</sup>Au or <sup>32</sup>P, the additional damage accompanying external irradiation may be relatively reduced. However, if the dose is sufficiently high, the marrow aplasia alone may produce the characteristic radiation-induced pancytopenia with its clinical consequences.

Lungs: Radiation injury to the lungs may result from intense irradiation from external sources and/or from internally deposited radionuclides. The injury is evidence by an early stage of radiation pneumonitis and a late stage of pulmonary fibrosis. The magnitude of the injury and its time course are related to the total radiation dose, dose rate, fraction of the lung

irradiated, and the condition of the lung before exposure. The effects of lung irradiation have been reviewed recently by Hahn (18).

There are virtually no data concerning the acute effects of inhaled radionuclides in man; however, dogs show qualitatively similar pulmonary effects and the doses required to produce them are consistent in many species, probably including man. Canine studies suggest that the rate of dose accumulation is the critical parameter for lethality and morbidity (18). Dogs show 100% morbidity after cumulative doses of 5000 rads or more from internally deposited radionuclides, and mortality following doses three to four times greater. The resultant dose response relationship is in reasonably good agreement with the available human experience. It suggests that pulmonary morbidity can reasonably be estimated by assuming a 100% incidence after 6000 rads and a 5% incidence after 3000 rads.

Gastrointestinal Tract: Fatal radiation-induced gastrointestinal injury and its clinical evidences result from the disruption of the normal proliferation of the intestinal epithelial lining. Reduction of the relatively radiosensitive stem-cell population results in a diminished flow of new cells required to line this high turnover system. However, lethal damage is produced only by radiation doses in the kilorad range (16) because there are a number of protective mechanisms enhancing the tolerance of the intestine to acute radiation damage (19).

Internal radionuclide contamination of gastrointestinal tract occurs after ingestion or inhalation. The dose to any particular segment of the tract is a function of the residence time of the contaminant in that segment, and the lower large intestine is therefore a region of major concern. No acute gastrointestinal injury from internal radionuclide contamination has been reported in humans so animal studies are the basis for current information.

Studies of Sullivan and Cross (1) indicated that internal irradiation from ingested beta emitting radionuclides can produce acute injury to the lower large intestine in dogs. An acute dose on the order of 3500-5000 rads at a critical depth in intestinal tissue is required for early lethality. Lower doses on the order of 2500-4000 rads cause significant morbidity and delayed death.

#### Modification of Radiation Injury by Medical Intervention

Bone Marrow: The most dramatic evidence of the effect of medical intervention is provided by the work on bone-marrow transplantation of Thomas and co-workers (7). In preparing leukemic patients for grafting, a 1000 rad midline tissue dose of total body  $^{60}\text{Co}$  irradiation was administered in less than four hours. In the majority of the 70 cases reviewed, bone marrow from an identical twin or closely matching sibling, administered immediately subsequent to the irradiation, grew successfully in the recipient. Although there were many subsequent fatalities due to recurrent leukemia, graft vs. host syndrome and infections, the evidences of the classical gastrointestinal syndrome did not occur in these individuals. Also, the classical changes associated with the hematologic form of the acute radiation syndrome did not materialize.

Another significant series is that of Rider who treated at least 22 Ewing's sarcoma patients with 300 rads whole body  $^{60}\text{Co}$  exposure delivered in a 15 minute period (18). Clinical management of these patients included a pre-treatment anti emetic, hospitalization through the 48 hour prodromal symptom period and subsequent discharge for outpatient observation until about 3 weeks postexposure when the signs of pancytopenia resulted in re-admission. In the management of the pancytopenia, the general approach was

to utilize barrier nursing; antibiotics for infections on their recognition, not prophylactically; and transfusions of red cells, platelets and, rarely, white cells when indicated. As previously noted, only one accident-related fatality occurred post-irradiation in 22 cases.

In view of the paucity of human data regarding treatment effectiveness, reliance has been placed, in particular, in dog studies (11,20) designed at evaluating the extent of improvement in mortality which active treatment can make possible. They suggest that supportive therapy can raise the LD50 by a factor of about 1.5. The utilization of more heroic treatment techniques such as bone marrow transplantation may increase the LD50 even further, by a factor of 3 or more.

Lungs: Another heroic treatment measure, lung lavage, has been proposed and utilized as a treatment technique for individuals accidentally exposed to relatively insoluble radionuclides. The initial canine studies (21) led to the use of the method of Kylstra et al. (22) in a human  $^{239}\text{Pu}$  inhalation accident patient (23).

A possible mortality incidence of approximately 0.5% can be inferred from the series in which this treatment was applied to patients with various types of severe obstructive lung disease (22). This must of course, be weighed against the risk of the potential presence of internal radioactive emitters in the lung in the intermediate or long term. Although there is little human data with which to judge the efficacy of the treatment, it has been suggested that it may reduce lung radioactivity by as much as 50 percent. In high level exposure this could be an effective and worthwhile result. For its optimal usage one would have to call on one of the few chest physicians who has had active experience with the technique.

Gastrointestinal Tract: Since the development of the classical GI syndrome requires that the functional efficiency of both the gastrointestinal and hematopoietic systems be altered (16), heroic treatment of the bone marrow injury may reduce mortality from the intestinal changes produced by total body external irradiation. When ingested radionuclides are the source of gastrointestinal radiation exposure, the gradual dose buildup in the intestinal tract provides adequate time to initiate the use of mild laxatives to accelerate excretion of contaminated ingesta. Such supportive treatment, which reduces the average intestinal dose by a factor of from 2 to 4 (24), is suggested for individuals receiving significant inhalation and/or ingestion exposure.

#### Availability of Medical Intervention

In considering the availability of medical modification for human acute radiation injury, we concentrated on the possible accidental exposures arising from nuclear industry operations rather than the catastrophic affects of the use of nuclear weapons. It was considered inconceivable that a serious industrial or reactor accident in the United States would not result in the mobilization of medical resources throughout the country to aid the exposed population. In view of the relatively slow tempo of the development of the manifestations of acute radiation injury in individuals whose exposure is within the range where treatment may increase survival, transportation to appropriate medical facilities within seven to ten days post-exposure is considered feasible. On this basis the availability of facilities for both supportive and heroic treatment was investigated.

Supportive measures including strict reverse isolation procedures, adequately managed major antibiotic therapy with appropriate microbiological laboratory support, and the ready availability of blood and blood products or transfusion can be found in most large acute medical and surgical hospitals.



One index of the availability of such services is an ongoing program in renal transplantation. Another index about which more quantitative information was obtainable was the approval program for the residency training of internal medicine residents (25). In 1975 there were 433 such approved programs, 90% of which were in hospitals affiliated with teaching institutions. These are generally large hospitals with an aggregate average daily census of 92,373 patients, so we estimated that each hospital could care for at least 5 to 10 severely irradiated people. On this basis, it was estimated that 2,500 to 5,000 people could receive adequate supportive treatment.

For the category of heroic treatment, the major demand would probably be for bone marrow transplantation. Our investigation showed that in 1975 there were 8 medical centers in the United States performing such transplantations on a regular basis while an additional 12 hospitals had newly started programs. It was estimated that each center might handle 5 such patients, providing a total of 50 to 150 people with such heroic treatment.

It is of interest to put the availability of these medical services into perspective in relation to the potential need. In the worst nuclear power reactor accident postulated in the Reactor Safety Study (1), corresponding to a probability of about  $10^{-9}$  per/reactor-year, the number of people receiving an exposure in the range of 350 to 550 rads and requiring active supportive treatment would be about 5,000. The number of exposures above this magnitude, where the need for heroic treatment would be anticipated, turned out to be zero in the study computations. Thus, it would appear that the facilities available for medical modification of acute radiation injury resulting from nuclear reactor accidents in the United States should be adequate to provide the necessary care for the exposed population.

#### REFERENCES

- (1) REACTOR SAFETY STUDY, Appendix VI, "Calculation of reactor accident consequences", WASH-1400 (NUREG-75/D14), U.S. Nuclear Regulatory Commission, Washington, D.C. (1975)
- (2) WARREN, S., BOWERS, J.Z., The acute radiation syndrome in man, *Ann. Int. Med.* 32 (1950) 207
- (3) UNSCEAR, Report of the United Nations Scientific Committee on the Effects of Atomic Radiation, United Nations, New York (1962) 123
- (4) NATIONAL COUNCIL ON RADIATION PROTECTION AND MEASUREMENTS, Radiological factors affecting decision-making in a nuclear attack, NCRP Report No. 42, Washington, D.C. (1974)
- (5) LANGHAM, W.H. (Ed.). Radiobiological factors in manned space flight, NAS-NRC Publication 1487, Washington, D.C. (1967)
- (6) LUSHBAUGH, C.C. "Human radiation tolerance", Ch. 10, *Space Radiation Biology and Related Topics* (TOBIAS, C.A., TODD, P., Eds), Academic Press, New York (1974)
- (7) THOMAS, E.D., et al., Bone-marrow transplantation, *New Eng. J. Med.* 292 (1975) 832 and 895
- (8) RIDER, W.D., HASSELBACK, R., The symptomatic and hematologic disturbance following total body irradiation of 300-rad gamma-ray irradiation. Guidelines to radiological health, U.S. Department of Health, Education and Welfare, Washington, D.C. (1968) 139.
- (9) CRONKITE, E.P., et al., Some effects of ionizing radiation on human beings, TID 5358, U.S. Atomic Energy Commission, Washington, D.C. (1956)
- (10) BIOMEDICAL AND ENVIRONMENTAL ASSESSMENT GROUP, Brookhaven National Laboratory, Personal communication, 1975
- (11) PERMAN, V., CRONKITE, E., BOND, V., The regenerative ability of hemopoietic tissue following lethal irradiation of dogs, *Blood* 19 (1962) 738
- (12) THOMA, G.E., Jr, WALD, N., The diagnosis and management of accidental radiation injury, *J. Occ. Med.* 1 (1959) 421

- (13) THOMAS, E.D., et al., Isogeneic marrow grafting in man, *Exptl. Hematol.* 21 (1971) 16
- (14) WALD, N. "Radiation injury", pp. 67-72, *Textbook of Medicine* (BEESON, P.B., MCDERMOTT, W., Eds), W.B. Saunders & Co., Philadelphia (1975)
- (15) WALD, N., THOMA, G.E., Jr, BROUN, G., Jr, Hematologic manifestations of radiation exposure in man, *Progr. in Hematol.* III (1962) 1
- (16) BOND, V.P., FLIEDNER, T.M., ARCHAMBEAU, J.O. *Mammalian Radiation Lethality*, Academic Press, New York (1965)
- (17) INTERNATIONAL ATOMIC ENERGY AGENCY. *Manual on Radiation Haematology*, Vienna (1971)
- (18) HAHN, F.F., Estimates of mortality due to radiation pneumonitis and pulmonary fibrosis after exposure to radionuclide releases in hypothetical light water reactor accidents, *Inhalation Toxicology Research Institute Report*, Lovelace Foundation, LF-5D (1975)
- (19) HAGEMANN, R.F., CONCANNON, J.P., Time/dose relationships in abdominal irradiation: A definition of principles and experimental evaluation, *Brit. J. Radiol.* 48 (1975) 545
- (20) CRONKITE, E.P., BOND, V., Diagnosis of radiation injury and analysis of the human lethal dose of radiation, *U.S. Armed Forces Medical Journal* 11 (1960) 249
- (21) PFLEGER, R.C., et al., Bronchopulmonary lavage for removal of inhaled insoluble materials in the lung, *J. Dis. Chest* 56 (1969) 524
- (22) KYLSTRA, J.A., et al., Volume-controlled lung lavage in the treatment of asthma, bronchiectasis, and mucoviscidosis, *Am. Rev. Respiratory Dis.* 103 (1971) 651
- (23) MCCLELLAN, R.O., et al., Recovery of  $^{239}\text{Pu}$  following bronchopulmonary lavage and DTPA treatment of an accidental inhalation case, *Health Phys.* 23 (1972) 426
- (24) NOLD, M.M., HAYES, R.L., COMAR, C.L., Internal radiation dose measurements in live experimental animals II, *Health Phys.* 4 (1960) 86
- (25) DIRECTORY OF APPROVED RESIDENCIES, 1974-75. *Am. Med. Assoc.*, Chicago (1975) 160

## CLINICAL EXAMINATIONS OF THE HUMAN SKIN EXPOSED TO LOW-LEVEL IRRADIATION

U. Lenz and W. Schüttmann

National Board of Nuclear Safety and Radiation Protection of the GDR, Berlin

## 1. INTRODUCTION

Some publications, e.g. the BEIR-Report (1), mention as possible somatic effects of low-level irradiation neoplasms, opacities of the lens, impairment of fertility, life shortening. In this connection effects to the skin are frequently not specified. This estimation might induce the opinion that the low-level irradiation may be without importance to the human skin. This idea must be rejected for several reasons, not least for the fact that the mechanisms leading to damage of the skin are only inadequately known. Another reason is the circumstance that the maximum permissible dose for hands, fore-arms, feet and ankles and with that also for the skin of these parts according to the recommendations of ICRP (2) are 75 rems in a year, a somewhat higher value compared with the then tolerance dose recommended for the first time in the 20's (3). In practice, the hands are those parts of the body in which the dose limits are frequently utilized to the full. Not seldom, they are furthermore overexposed at some special places of work. On these conditions the accumulated working lifetime dose at the hands may reach the value of 3,000 rems. This dose is within the range of the carcinogenic effects of ionizing radiation regarding the human skin (4,5,6,7,8). We observed skin cancers of the hand in persons occupationally exposed to X-rays in the mentioned range (9). In some cases these carcinomas were situated in areas of the skin without typical signs of radiodermatitis, in accordance with similar observations published by other authors (1,4).

The above mentioned observations and reflections made us study the problem of irradiation effects to the human skin in the low-level range by means of clinical methods, other than done by authors who tried to clear up this question by way of questionnaires (10). We intended especially to find objective methods revealing early changes before the development of macroscopically detectable typical radiation induced abnormalities. Furthermore, the results of our examinations should indicate whether the recommendations of ICRP (2) for the maximum permissible dose for the hand must be revised or not. The examinations have been performed at the Dermatological Department of the National Board of Nuclear Safety and Radiation Protection.

## 2. MATERIALS, METHODS AND RESULTS

The investigation has been done with two collectives, first with patients irradiated therapeutically for benign degenerative diseases of single joints and second with occupationally exposed persons.

## 2.1. Examination of therapeutically irradiated persons

50 patients with a degenerative disease of a single joint (elbow, shoulder, knee or hip) were irradiated with four fractions in the course of one month. The total doses on the irradiated fields were between 200 and 1,200 rads. The examination took place from 6 months to two years after the last irradiation. The symmetrical region of the joint of the other side served for control. Furthermore, 50 healthy persons without any radiation exposure were examined in the same manner, at a time the joints of both sides.

The following methods have been used:

- Macroscopic findings of the skin
- Capillary microscopy, especially the assessment of the connection between arterial and venous side
- Function tests for capillary reaction
  - . Intracutaneous adrenaline test (assessment of the capillaries' contractility)
  - . Intracutaneous histamine test (assessment of the capillaries'
    - a) ability for dilatation (area of erythema)
    - b) permeability (area of wheal)
  - . Capillary resistance according to NESTROW
- Measurement of the skin pH.

As expected, the macroscopic findings were unobvious. The microscopic examination of the capillaries detected only in four cases, all with a dose of more than 800 rads, some changes indicating the beginning of irreparable alterations of the vessels. Besides discrete morphologic deviations of some single capillaries there was a special elucidation of the capillary bed in all, perhaps caused by a beginning rarefaction of the vessels. The measurement of the skin pH did not give any positive results. Among the several function tests only the histamine test yielded a positive finding. It showed a reduction of the histamine induced erythema area compared with the different controls, but only in skin fields irradiated with more than 800 rads. The significance of this finding was less than 5 per cent. It indicates a certain restriction of the capillaries' ability for dilatation. The test finding corresponds somewhat with the deviations found by capillary microscopy. The results of the histamine test are not very clear-cut so that the function tests in all are not suitable screening methods to detect early radiation induced reactions of the skin.

## 2.2. Examination of occupationally exposed persons

Up to now, a selected group of 45 occupationally exposed persons (reactor physicists, radiochemists, roentgenologists, X-ray technicians) with special hand exposures has been examined by means of the following methods:

- Macroscopic findings of the skin
- Dactyloscopy (printing method and macrophotography)
- Capillary microscopy (assessment of the perionychium)
- Thermography of the hands by means of liquid crystals (contact thermography)
- In cases of deviating findings in capillary microscopy additionally exploratory excision and histologic investigation.

The examined persons did not show any macroscopically detectable deviations. Also the dactyloscopy did not reveal any changes. In 13 cases (about 30 per cent of all examined persons), working in the fields of X-ray diagnostics, nuclear medicine, nuclear physics and radionuclide production, anomalies were uncovered by capillary microscopy. The duration of exposure of these 13 persons was between 8 and 25 years. There were no radiation accidents in the case histories of these persons; but some of them reported on occasional hand contaminations. In some cases dosimetric estimations by sampling measurements have been possible. The established doses are between about 1,000 and 3,000 rads. In the other cases no hints to much higher doses could be obtained. The capillary changes at the perionychium were somewhat different among the 13 persons. Mostly, the changes were more developed on the right hand than on the left one, especially on the second and third finger. The changes of the vessels covered poor contouring, disintegration of the palisade-like arrangement of the capillaries, retraction of the arterial and venous sides of the vessels, development of discrete ectasias or obliterations. Frequently, budding out of single capillaries could be seen in the proximal areas of the perionychium.

The thermographic investigation of the 13 persons with capillary anomalies revealed in eight cases remarkable discrepancies. The distal phalanxes showed surprisingly hyperthermic areas, still more with the help of dynamic function tests. In these areas the recalescence time after measured cooling down of the hands was distinctly shortened. It is difficult to interpret this finding. It corresponds with similar pictures at the early stage of acute radiation damage of the skin. Perhaps it represents the early capillary response to irradiation before the definite involution of the vessels bed.

In all 13 persons with capillary microscopic findings an exploratory excision in the most affected area was performed. The histologic investigation aimed especially at changes of the epidermis and at reactions of the vessels and of the connective tissue in the corium. All cases had more or less typical findings. There were alterations of the vessels in the form of wall fibrosis, constricted or dilated lumina, endothelial swelling, perivascular infiltrations. In addition to the changes of the vessels the corium repeatedly presented swollen, denucleated, partially degenerated fibers. In three cases nuclear pyknosis and polymorphism could be seen in the epidermis, always in addition to distinct changes in the corium. These three persons showed also the most severe alterations in capillary microscopy.

Despite the until now small number of cases, the results of the histologic investigation make it possible to classify the detected changes in three categories with regard to their extent:

- I: Changes only of vessels in the upper corium
- II: Changes of vessels and connective tissue in the corium
- III: Changes both in the epidermis and the corium.

So far, our investigation has the result that the earliest response of the skin to low-level-irradiation has to be seen

in the alterations of the vessels in the corium. Typical changes of the cells in the epidermis are to be found only at a later date or after a greater exposure. There is a good correlation between the capillary microscopic and the histologic findings. Therefore the capillary microscopy seems a suitable screening method for the detection of early radiation induced skin reactions. Our investigation will be continued in consideration especially of a better dosimetric evaluation of the examined persons. We hope to get in this way some further information with regard to the dose-effect-relation of the described changes.

### 3. CONCLUSIONS

The results of the presented investigation call for several consequences. These consequences concern the methods of medical and dosimetric supervision of radiation workers with a special exposure of the hands. Furthermore they contribute to the discussion on the interrelation between the changes in the epidermis and the alterations of the corium especially with respect to the carcinogenic effects of the ionizing radiation. The most important consequence concerns the recommendations for the maximum permissible dose. The described changes have been caused by a chronic long-time exposure with a total dose in the range which can be achieved also by a lifelong exposure within the limit of 75 rems in a year. This limit value seems the only one which enables the development of somatic damage including carcinogenesis. Therefore, this limit should be revised. This demand has already been made by other sides. 1971, for example, a British forum of experts (11) concluded a discussion on this topic with the statement that the dose limit of 75 rems in a year is unacceptable and that the lower limit given by ICRP for skin, namely 30 rems in a year, should apply to all parts of the body. Considering the results of our investigation we would like to support this suggestion.

### REFERENCES

- ( 1) Report of the Biological Effects of Ionizing Radiations, National Research Council, 1972
- ( 2) ICRP Publication No. 9, Pergamon Press, 1966
- ( 3) SCHÖTTMANN, W., Zur Geschichte der Strahlenschutzgrenzwerte, Report SAAS 201, 1976
- ( 4) MOLE, R.H., Radiation induced tumors - human experience, Brit.J.Radiology 45 (1972) 613
- ( 5) PEGUM, J.S., Radiation induced skin cancer, Brit.J. Radiology 45 (1972) 613
- ( 6) ROWELL, N.R., Discussion remarks, Brit.J.Radiology 45 (1972) 610
- ( 7) EMMET, E.A., Occupational skin cancer: a review, J.occup. Med. 17 (1976) 44
- ( 8) Medical News, J.Amer.med.Ass. 235 (1976) 1823
- ( 9) ARNDT, D., et al., Plattenepithelcarcinom der Haut mit Todesfolge bei einem beruflich strahlenexponierten Stomatologen, Berufs-Dermatosen 23 (1975) 201
- (10) ELLIS, R.E., Radiation dose and minimal reactions in chronically irradiated skin, Brit.J.Radiology 45 (1972) 612
- (11) Special report No 6, Radiobiology forum on radiological protection and the skin, Brit.J.Radiology 45 (1972) 617

CHROMOSAL ABERRATION IN PERSONS  
OCCUPATIONALLY EXPOSED TO X-RAYS

M. Kilibarda, B. Marković, D. Panov  
Institute of Occupational and  
Radiological Health, Beograd  
Yugoslavia

## 1. INTRODUCTION

A general development as well as more and more extensive use of electronics and nuclear energy result in increased number of persons exposed to ionizing radiations. Therefore, it becomes necessary to make a precise defining of biological effects of radiations during periodical medical examinations in those persons. The analysis of chromosome aberrations in peripheral blood lymphocytes represent one of the best of biological parameters for evaluation of damages effected by radiations. Those investigations are performed in the patients prior and after radiotherapy (1,2), in the persons who had undergone X-Ray diagnostic examinations (3), in the persons who have been exposed to ionizing radiations occupationally (4,5,6), and in the persons who had been irradiated accidentally (7).

## 2. MATERIAL AND METODOLOGY

The investigations have been carried out in the group of 100 persons exposed to ionizing radiations occupationally and in the group of 20 persons who represented a control group. The analysis of chromosomes in peripheral blood lymphocytes were carried out after a modified method by Moorhead et al. (8). The culture was incubated for 48 hours.

Number of cells that has been analysed depends both on metaphase frequency and chromosome quality. In the most cases there have been analysed 100 of cells.

### 3. INVESTIGATION RESULTS

All examined persons, who had been exposed to ionizing radiations occupationally, have been divided into three groups.

The first group included 46 of X-Ray technicians and 4 persons of the other professions. All persons of this group have been divided into subgroups to their exposure duration. The investigations results showed that the highest frequency of aberrant cells was found to be present in the persons having exposure duration higher than 21 years.

In Table 2 there are presented the results of frequency of chromosome aberrations in 21 of phthisiologists. As the table indicates there are no increased frequency of chromosome aberrations in relation to exposure duration. This can be explained by the fact that for ten years past, the practice of phthisiologists involves the diascopic examinations very rarely which results in their insignificant exposure to ionizing radiations.

For the third group (Table 3) there are presented the results of examinations in 29 of radiologists. All of them have been engaged in ambulance-polyclinic services for X-Ray diagnostics. They have been divided into three subgroups to their exposure duration. These investigations results indicated to significant frequency of chromosome aberrations in the subgroup having exposure duration higher than 11 years.

### 4. SUMMARY

The group of 100 persons exposed to ionizing radiations have been examined. The results of these examinations in relation to the control group showed a significant frequency of chromosome aberrations in radiologists, and in X-Ray technicians it was found to be of lower value, and in the phthisiologists it was insignificant.



The presented results bring up to the conclusion that the investigations of chromosome aberrations represent one of biological tests that permits an early finding of damages effected by ionizing radiations.

Occupation	Years of exposure	Number of persons	Number of analysed cells	Number of aberrant cells		Examined persons having values higher than in control group	
				No	%	No	%
X-Ray technicians	6-10	12	1200	41	3,4	5	41,6
	11-15	15	1330	45	3,4	5	33,3
	16-20	9	887	38	4,3	4	44,4
	more than 21	10	921	41	4,4	7	70
Other professions	4-18	-	389	41	10,5	3	75
Controls	-	20	1756	39	2,2	1	5

Table 1. Frequency of chromosome aberrations in X-Ray technicians

Occupation	Years of exposure	Number of persons	Number of analysed cells	Number of aberrant cells		Examined persons having values higher than in control group	
				No	%	No	%
Phtisiologist	11-15	8	803	29	3,6	3	37,5
	16-20	7	604	22	3,6	2	28,5
	more than 21	6	511	24	4,7	2	33,3
Controls	-	20	1746	39	2,2	1	5

Table 2. Frequency of chromosome aberrations in phtisiologists

Occupation	Years of exposure	Number of persons	Number of analysed cells	Number of aberrant cells		Examined persons having values higher than in control group	
				No	%	No	%
Radiologist	6-10	9	875	28	3,2	1	11,0
	11-15	13	1261	50	3,9	7	53,8
	more than 16	7	736	49	6,2	6	85,7
Controls	-	20	1746	39	2,2	1	5

Table 3. Frequency of chromosome aberrations in radiologists

REFERENCES:

1. Tunkl, M., Radiation effects of J-131 on human chromosome, M.sc. dissertation, Zagreb (1966)
2. Court-Brown W.M., Buckton K.E., Langlands A.O.: Int. Journ. Rad. Biol. 13, 2, 155 (1967)
3. Pendić B., Lovrić Lj.: Bulletin of transfusion 26, 41 (1970)
4. Lsebok Z., Stark K.: Magy Radiol. 22, 331, (1970).
5. Sasaki M., Ottoman R.E., Norman A.: Radiology 81, 652 (1963).
6. Brandon W.F., Saecomanno G.: Radiat. Res. 52, 204(1972)
7. Pendić B., Djordjević O.: Jugoslav. Physiol. Farmacol. Acta 4, 231 (1968)
8. Moorhead P.S., Nowell, P.C., Mellnan W.J., Battips D.M., Hungerford D.A.: Exp.Cell. Res. 20, 613 (1960)

UTILISATION DES ANALYSES CHROMOSOMIQUES POUR L'ESTIMATION  
D'UNE DOSE D'IRRADIATION ACCIDENTELLE CHEZ L'HOMME.

M.T. Doloy, R. Le Gô, G. Ducatez, J. Lepetit, M. Bourguignon.

Département de Protection  
Section de Radiopathologie  
Centre d'Etudes Nucléaires  
92260 Fontenay-aux-Roses.

La physiologie particulière des lymphocytes rend ces cellules parfaitement adaptées à l'évaluation des dommages chromosomiques radioinduits lors d'une irradiation corporelle globale et aigue :

- conservation telles quelles des anomalies chromosomiques radio-induites dans les lymphocytes pendant plusieurs semaines grâce à l'absence d'activité mitotique spontanée.
- homogénéisation de la population lymphocytaire dans le sang.
- facilité de prélèvement et d'irradiation expérimentale in vitro.
- possibilité d'observer telles quelles les anomalies chromosomiques radio-induites, dans l'organisme ou in vitro, lors de la première division des lymphocytes en culture (48 heures).
- similitude d'induction des anomalies chromosomiques dans les lymphocytes irradiés in vivo ou in vitro, constatée lors d'expériences sur animaux.

Le présent rapport présente la comparaison entre des dommages produits dans les lymphocytes irradiés in vitro et les dommages observés chez des sujets soumis à une irradiation corporelle aigue globale. L'estimation de dose déduite de cette comparaison est confrontée à celle fournie par la dosimétrie physique.

#### 1. MATERIEL ET METHODE.

La technique de culture de lymphocytes (culture de 48 heures) a été précédemment décrite(1). Des échantillons de sang de sujets normaux ont été soumis à température ambiante au rayonnement gamma du Cobalt 60, à un débit de 50 rads/min. pour les doses inférieures à 1000 rads et 100 rads/min. au delà. La mise en culture a eu lieu dans les 30 minutes suivant la fin de l'irradiation. L'effet de 11 doses comprises entre 25 et 1800 rads a été étudié. Au minimum 250 cellules ont été examinées pour chacune des doses, sauf pour les deux plus fortes pour lesquelles le taux de mort cellulaire était très important. La dose de 400 rads a été particulièrement bien étudiée dans le but de vérifier l'influence de divers facteurs sur l'induction d'anomalies. Pour chaque cellule, les chromosomes ont été comptés et les anomalies directement observables au microscope, notées (dicentriques, anneaux, fragments).

L'irradiation corporelle a été globale pour tous les cas présentés dans ce rapport. Elle a été relativement homogène dans les 9 premiers cas et nettement hétérogène dans les autres

cas (Tableau 3). Pour chaque cas, une estimation de la dose moyenne observée a pu être calculée d'après les dosimètres individuels ou la reconstitution chronométrée de l'accident. Chaque examen chromosomique a porté sur 250 cellules à l'exception de l'examen n° 14 où seulement 50 cellules ont pu être analysées. Le délai entre l'irradiation et le prélèvement n'a pas dépassé une semaine en règle générale et a été au plus de 4 semaines. La durée d'exposition n'a pas dépassé une heure; à l'exception du sujet 10, exposé pendant 4 heures.

## 2. RESULTATS.

Les résultats de l'irradiation de sang in vitro (tableau 1) a permis l'établissement de courbes et de relations dose-effet (tableau 2) pour les 3 types d'anomalies chromosomiques considérés. L'effet radio-induit ayant tendance à se saturer aux très fortes doses, les résultats correspondants à des doses supérieures à 800 rads n'ont pas été prises en considération pour la recherche des relations dose-effet, effectuées par la méthode des moindres carrés, en pondérant chaque valeur du nombre moyen d'anomalies par cellule, par l'écart-type de cette valeur.

Les distributions du nombre d'anomalies par cellule suivent de très près la loi de Poisson pour les dicentriques et les "dicentriques plus anneaux" mais s'écartent de cette loi pour les fragments, dont l'origine en effet, est multiple.

Le report de la fréquence d'anomalie observée pour chaque sujet ainsi que l'écart type de cette valeur sur les courbes dose-effet, permet de définir un créneau de dose qui aurait produit le même effet, administré in vitro. Dans l'ensemble ces estimations de dose sont compatibles avec les données de la dosimétrie physique et avec les syndromes hématologique ou clinique .

## 3. CONCLUSION.

Ces résultats viennent confirmer la possibilité d'établir une dosimétrie biologique en cas d'irradiation aigue pour des doses d'une dizaine de rads et au-delà. Seul le nombre de cellules nécessaires à l'examen, limite le niveau de dose étudié. Un tel dosimètre semble le mieux adapté aux cas d'irradiation corporelle homogène où la notion de dose moyenne absorbée intéresse tout particulièrement le clinicien. Cependant, en cas d'irradiation hétérogène la distribution du nombre d'anomalie par cellule peut fournir une confirmation sur l'hétérogénéité de dose.

La longue stabilité de la fréquence des anomalies chromosomiques dans les lymphocytes des sujets 6 et 11, montre la possibilité d'utiliser cet examen en tant que dosimètre biologique pendant plusieurs semaines voire plusieurs mois après une irradiation aigue.

## REFERENCE

- (1) BIOLA M.T. et Coll. "Biological effects of neutron irradiation" AIEA 1974 - 221.

Dose	Nombre cellules	Dicentriques			Dicent. + Anneau			Fragments		
		Nombre observé	$\bar{x}$ -anomal. par cellule	$\sigma^2$	Nombre observé	$\bar{x}$ -anomal. par cellule	$\sigma^2$	Nombre observé	$\bar{x}$ -anomal. par cellule	$\sigma^2$
0	1400	0	0		0	0		11	0.008	0.002
25	305	3	0.001	0.006	5	0.016	0.007	6	0.020	0.009
50	300	6	0.02	0.008	8	0.026	0.009	9	0.03	0.012
100	316	25	0.079	0.015	28	0.088	0.017	23	0.07	0.017
200	539	137	0.25	0.021	138	0.29	0.023	72	0.13	0.018
400	2421	1834	0.76	0.017	2060	0.85	0.019	1420	0.59	0.018
600	250	408	1.63	0.071	454	1.82	0.078	286	1.14	0.079
800	250	637	2.55	0.10	718	2.87	0.11	453	1.81	0.10
1000	267	966	3.62	0.059	1092	4.09	0.11	531	1.99	0.11
1200	287	1385	4.83	0.22	1576	5.49	0.13	287	3.24	0.13
1500	100	683	6.83	0.19	770	7.70	0.21	100	4.92	0.29
1800	50	406	8.12	0.35	443	8.86	0.37	50	5.5	0.4

Tableau 1. Irradiation expérimentale in vitro.

	$Y = a D^n$			$Y = a D + b D^2$			
	$a \cdot 10^5$	n	$\chi^2$	$a \cdot 10^4$	$\bar{a} \cdot 10^4$	$b \cdot 10^6$	$\bar{b} \cdot 10^6$
Dicentr.	3.47	1.677	0.01	4.304	0.827	3.636	0.194
Dicentr. + Anneau	2.96	1.721	0.0146	5.453	0.821	3.950	0.192
Fragm.	3.82	1.58	0.03	3.051	1.378	2.680	0.325

Tableau 2. Relations dose-effet.



SUJET	1	2	3	4	5	6	7	8	9	10	11	12	13	14	
<u>RAYONNEMENT</u>															
Nature	X	γ	γ	γ	γ	γ	γ	γ	γ	γ	γ	γ	γ	γ 90% n10% div.	
Source		192 Ir	192 Ir	192 Ir	192 Ir	60 Co	60 Co	60 Co	60 Co	192 Ir	192 Ir	192 Ir	60 Co		
Activité (Ci)		50	75	75	75	80000	80000	7500	7500	14	60	60	-	réact	
<u>EXPOSITION</u> (homogénéité)															
	++	++	+	+	+	+++	+++	+	+	---	--	-	---	---	
<u>ESTIMATION DOSE</u> (rads)															
•Dicentriques	0	40	25	40	17	92	60	28	17	40	110	25	1200	490	
Créneau dose {		25	12	25	0	78	45	12	0	25	95	12	1170	430	
		50	35	50	25	100	70	35	25	50	120	35	1210	450	
•Dic. - Anneaux	17	45	25	38	17	100	70	27	25	45	110	25	1200	480	
Créneau dose {		0	32	12	25	0	85	55	12	12	32	100	12	1150	425
		25	70	35	50	25	110	85	35	35	70	125	35	1200	535
•Fragments	25	22	22	25	0	100	40	0	16	80	120	-	1300	500	
Créneau dose {		0	0	0	0	70	17	-	0	40	100	-	1250	440	
		50	40	40	45	120	60	-	30	100	140	-	1350	600	
•Dosimétrie physique {		5	15	20	20	2	100	70	10	8	50	10		550	
			80	80	3				14	10	200	40			
Syndrôme hématologique	0					++	++				++	+	++++	++++	

Tableau 3 - Irradiation accidentelle globale.

EARLY DETECTION OF RADIATION-INDUCED CELL MEMBRANE  
ALTERATIONS BY LECTIN-BINDING

Tamara Kubasova, Lilla Csáky, G.J.Köteles, I.Varga and  
L.R.Sztanyik

"Frédéric Joliot-Curie" National Research Institute for  
Radiobiology and Radiohygiene, H-1775 Budapest 22, Hungary

1. INTRODUCTION

In recent years considerable amount of new data have accumulated concerning the structure and function of cell membranes. The fluid mosaic model /1/ reflects a highly complex and flexible entity which might change rapidly upon external or internal effects. The various receptors are integral parts of plasma membranes and play decisive roles in the reaction of the cell against its environment. Recently, we have demonstrated /2/ that ionizing radiation induces a temporary disturbance on the surface structure of human fibroblasts as detected by the H-3-Concanavalin A binding capacity of these cells. Preliminary data have suggested that similar phenomena can be observed in blood cells /3/. Therefore, a more detailed investigation was initiated to reveal whether this observation would lead to development of a new method to detect the effect of radiation on the cell membranes.

Our present data suggest that in vitro lectin-binding tests can be applied successfully to reveal surface alterations of blood cells obtained from in vivo irradiated mice.

2. MATERIALS AND METHODS

CFLP mice of 20-25 g weights were whole body x-irradiated with 50, 100, 250 and 500 R /THX-200 x-ray apparatus, 180 kV, 15 mA, S.S.D. 60 cm, 0,5 mm Cu, 25,5 R/min/. Blood samples of 3 animals per each time point were collected 0,5, 1, 2, 3, 6 and 24 hours after irradiation. Blood cells were separated by Ficoll density gradient centrifugation. Isolated fractions enriched in lymphocytes and erythrocytes were incubated with H-3-Concanavalin A at 37°C for 10 and 30 minutes respectively /3H/G/-Concanavalin A, New England Nuclear, 40,9 Ci/mM; 5 µg/ml; 4,8 µCi/ml/. The cells were washed after incubation with phosphate buffered saline and smears were prepared for autoradiography /dipping method, Ilford Nuclear Research emulsion Type G5; exposition for two weeks at 4°C, fixation and staining with 5% Giemsa solution/. Grains were counted in 100 cells for each dose and time point.

### 3. RESULTS AND DISCUSSION

The in vitro H-3-Concanavalin A binding capacities of mouse peripheral lymphocytes at various time points after in vivo whole body x-irradiation with different doses are demonstrated on Table I. The amount of the bound lectin changed upon the effect of irradiation within a few hours. At lower doses /50 and 100 R/ an initial increase was followed with a deep decrease after 3 hours. Higher doses /250 and 500 R/ resulted only in the inhibition of lectin receptors. The data obtained 24 hours after irradiation suggest that the receptors regained their full binding capacities.

The same tendency of the H-3-Concanavalin A binding was observed after x-irradiation of isolated mouse spleen lymphocytes, when measured by liquid scintillation /3/. In the latter case, however, no depression below the unirradiated control level was observed.

In the presence of 0,4 M alpha-methyl-D-glucoside, an inhibitor of concanavalin A binding to the plasma membrane, the cells bound appr. 30% of the lectin amount when compared to the uninhibited cells. It is interesting to note that the radiation-induced inhibition of receptor activity reduced the lectin binding to the same extent.

A less striking alteration of lectin binding was found in the erythrocytes. Only about 30-35% of the circulating erythrocytes were labelled by H-3-Concanavalin A. This fraction, however, was extended upon irradiation during the first 3 hours. Doses up to 250 R elevated the labelling index, while higher doses did not change it. Work is in progress to study in more details the lectin binding of erythrocytes and other blood elements, e.g. thrombocytes, which seem to have a high affinity to H-3-Concanavalin A.

In conclusion, a rapid and temporary alteration of H-3-Concanavalin A receptors in the plasma membranes of mammalian blood cells was demonstrated as an effect of ionizing radiation. The directions and extents of the receptor changes depend on the radiation doses. Further experiments are planned to elucidate whether the phenomenon can be used as an early indicator of radiation effects.

#### REFERENCES

- /1/ Singer, S.J. and Nicolson, G.L./1972/ Science, 175, 720.
- /2/ Kőteles, G.J., Kubasova, T. and Varga, L./1976/ Nature, 259, 507.
- /3/ Csáky, L., Kubasova, T., Kőteles, G.J. and Varga, L./1976/ Proc. 12th Meeting of the European Society for Radiation Biology, Budapest, Hungary.



TABLE I

H-3-Concanavalin A Binding in vitro of Mouse Peripheral Lymphocytes After Various Doses of in vivo X-Irradiation

Time in hours after irradi- ation	Doses in R			
	50	100	250	500
Unirradiated control	4,8 $\pm$ 0,4			
0,5	2,9 $\pm$ 0,2 /60/	3,6 $\pm$ 0,2 /75/	4,7 $\pm$ 0,4 /98/	5,8 $\pm$ 0,5 /121/
1	6,6 $\pm$ 0,3 /138/	8,0 $\pm$ 0,3 /167/	3,4 $\pm$ 0,2 /71/	1,5 $\pm$ 0,3 /31/
2	5,1 $\pm$ 0,3 /106/	10,4 $\pm$ 0,7 /217/	4,7 $\pm$ 0,2 /98/	1,0 $\pm$ 0,1 /21/
3	2,6 $\pm$ 0,2 /54/	1,8 $\pm$ 0,2 /38/	1,5 $\pm$ 0,1 /31/	1,5 $\pm$ 0,1 /31/
6	1,2 $\pm$ 0,2 /25/	1,4 $\pm$ 0,2 /29/	1,7 $\pm$ 0,1 /35/	2,6 $\pm$ 0,2 /54/
24	5,5 $\pm$ 0,4 /114/	5,8 $\pm$ 0,4 /121/	4,3 $\pm$ 0,6 /90/	4,4 $\pm$ 0,4 /92/

The average number of grains per cell, the S.E. and the values in percentage of the unirradiated control are tabulated.

**ASPECTS OF CHELATION CHEMISTRY OF  
TRANSURANIUM ELEMENTS FOR THEIR REMOVAL FROM BODY**

M.B. Hafez, H.M. Roushdy and N. Hafez

Radiation Protection department and  
National center for Radiation Research and  
Technology. Atomic Energy Establishment  
Cairo . Egypt.

**1 - INTRODUCTION**

As a result of increasing use of plutonium and other transuranium elements in peaceful and defence purposes, probability of deposition of these elements within the body is increasing. This review includes a quantitative aspect of chelation between transuranium elements and polyaminopolycarboxylic acids.

**2 - METABOLISM OF TRANSURANIUM ELEMENTS :**

The metabolic behaviour of transuranium elements in the body depends on a number of chemical and biological factors such as the influence of pH of the contaminated elements, its valency or dilution with isotopic and nonisotopic carrier, age and if the compound is in ionic or colloidal state

**3 - DECONTAMINATION OF TRANSURANIUM ELEMENTS :**

Therapy for transuranium contamination is done by increasing the radio element extraction from the body through the use of chelating agent. This has been proved to be the most promising approach (1). The polyaminopolycarboxylic acids, in particular, have been used as decontaminating agents in view of their superiority to other organic chelating agents.

**4 - CHELATION OF TRANSURANIUM ELEMENTS :**

The transuranium elements, neptunium, plutonium, and americium exist in aqueous solutions in four possible oxidation states MIII, MIV, MV, MVI. Trivalent plutonium and americium are relatively stable in solution of medium acidity, . At a pH of about seven, however, the first small quantities of the hydrolysis product  $M(OH)^{++}$  appears, and at only slightly higher pH, either basic salts or the hydroxides precipitate. Pentavalent states are existed as oxy-ion  $MO_2^+$  in aqueous solutions. Hexavalent ions, are relatively stable in aqueous solution and exist as oxy-ion. Tetravalent plutonium is easily hydrolysed and polymerised

Depending upon the cation's charge, its size and electronic configuration, each cation can saturate a certain number of donor atoms. This number is called co-ordination number. The trivalent transuranium cations complexes exhibit co-ordination number 6, the ligands occupy the corners of an octahedron in the center of which the central atom stands, while tetravalent ions offer coordination number 8 which has cubic arrangement(2). The stability of a 1:1 chelate formed by reaction of an aquated ion ( $M^{+n}$ ) with a polyaminopolycarboxylate ( $Y^{-x}$ ) according to the equation.



is given by the magnitude of the formation constant

$$K = (MY^{n-x}) / (M^{+n})(Y^{-x})$$

A number of such values, expressed in logarithmic form, are summarised in table. Comparisons among various chelating agents for individual cations reflect upon stability of such properties of the ligand as structure, steric limitations, basicity, and a number of possible rings. Of greater interest, however, are comparisons among the various metal ions for a given chelating agent. In all instances, a generally regular increase in stability with increasing atomic number ( or decreasing crystal radius ) from  $Np^{+3}$  to  $Am^{+3}$  is found. The bonding in these chelates is purely electrostatic. The absence of extensive covalent bonding in such complexes is dictated both by electronic configurations of the cations and by their large size. Shielding of the 5f electrons is sufficient to render them sterically unavailable for extensive bond formation and thereby distinguish them from the d electrons of the regular transition metal ions. Participation of available 6d orbitals in bond formation is a possibility, but against this must be cited that rare earth metal compounds have ionic properties.

The present investigation intends to find a suitable chelating agent for transuranium elements decontamination. For this purpose the stability constants of some transuranium complexes with polyaminopolycarboxylic acids have been chosen (3) The stability constant of the chelates is taken as a

comparative measure of the effectiveness of the chelating agent. The collected data are grouped in table 1. From the analysis of these results the following conclusions may be reached.

Chel. agent	Stability constant			
	PuIII	PuIV	NpV	AmIII
EDTA	18.0	23.2	10.2	18.3
DCTA	18.8	23.9	10.6	19.1
DTPA	19.3	24.4	11.2	19.6
TTHA	18.8	24.1	10.9	18.9

- (1) Tri and tetravalent cations formed 1:1 soluble complexes
- (2) The pH at which the complex is formed slightly varies as the ionic radius as well as the number of the coordinating groups decreases.
- (3) The stability constant, for the same chelating agent, increases from plutonium to americium.
- (4) The stability constant increases as the number of donor atoms increases i.e in the order EDTA, DCTA, TTHA, and DTPA.
- (5) The polyaminopolycarboxylic acids can readily chelate freshly tri and hexa valent colloides, As the age time increases, solubilisation becomes more difficult and hence longer contact time is necessary. No appreciable chelation of tetravalent state could be obtained.

In case of chelation of transuranium elements IN VIVO, several factors must be taken into consideration such as calcium ion which present in large quantity in serum and other extracellular fluids, can be also chelated, the penetrability of polyaminopoly-carboxylic acids into cells differs from one chelating agent to another, and the free metal ions form complexes with polyproteins, polypeptides and polynucleic acids existed in body. These complexes

dissociate too slowly to be influenced by the chelating agent.

#### 5 - CONCLUSION

The diethylenetriaminepentaacetic acid (DTPA) and the triethylenetetraaminhexaacetic acid (TTHA), from the chemical point of view, can be recommended for transuranium elements decontamination. This is due to their high stability in aqueous solution. Further additional quantitative studies should concentrate to evaluate the toxicity and therapeutic range of DTPA and TTHA administered over an extended period. However further studies should investigate these two chelating agent INVIVO as regards the relationship of the effectiveness of DTPA and TTHA to different biological parameters such as space, level, number of doses and time of administration.

#### REFERENCES

- 1) CATSCH, A. and SEIDL, D., " Diagnosis and treatment of radioactive poisoning, IAEA, Vienna ( 1963 ) .
- 2) HOARD , J.L., SMITH, G.S. and LIND, M. " In advances in the chemistry of the co-ordination compounds" (edited by KIRSCHNER, S. ) , 296, Macmillan, New York ( 1961 )
- 3) GEL'MAN, A.D., " Complex compounds of Actinide elements" translated from Russ., consultant Bureau, New York(1962)

IRPA IVth INTERNATIONAL CONGRESS, PARIS, FRANCE 1977

DTPA RESEARCH AT THE UNIVERSITY OF UTAH

Charles W. Mays, Glenn H. Taylor, Ray D. Lloyd, Susan S. McFarland,  
Darrell R. Fisher, Scott E. Calder, and Jerald Boseran

Radiobiology Laboratory, University of Utah Medical Center  
Salt Lake City, Utah, U.S.A. 84132

(Supported by USERDA Contract EY-76-C-02-119)

1. INTRODUCTION

This paper summarizes some of our recent research. Further details are given in the references. DTPA (diethylenetriaminepentaacetate) is an effective chelating agent for removing transuranic elements from the body. Ca-DTPA (calcium trisodium DTPA) is the form most commonly used but, unfortunately, it also depletes the body of zinc and manganese, which are essential for cellular division [1,2]. Thus, Ca-DTPA can be toxic under certain conditions. Zn-DTPA (zinc trisodium DTPA) does not deplete the body of Zn or Mn and, consequently, is much safer than Ca-DTPA. We have been particularly concerned with both the safety and the efficacy of these chelates.

2. TOXICITY OF Ca-DTPA

We were surprised to find that when the recommended daily dose of Ca-DTPA for humans (1 g Ca-DTPA/70 kg man/day, or 30  $\mu$ mole Ca-DTPA/kg/day) was injected into three adult beagles in 5 fractions per day (6  $\mu$ mole Ca-DTPA/kg each 4 to 5 hours), all of the dogs died after 4 to 9 days of continual therapy with severe degeneration of the intestinal lining [3]. The effect was much less severe in four other dogs from the same experiment, injected once a day with about 30  $\mu$ mole Ca-DTPA/kg for 8 days, although some anorexia, emesis, and diarrhea were noted [3]. The finding of increased toxicity of Ca-DTPA with increased frequency of administration has also been confirmed in rats [4]. The effect of Ca-DTPA on the fetus is much more severe than on the adult [5-8]. Scaling from mice and rats to humans, with a metabolic model based on the rate of replenishment of zinc from the diet, we predicted that human fetal toxicity might occur at the presently used daily dose [9]. To test this prediction in a large experimental animal, we gave two pregnant beagles daily intravenous injections of 30  $\mu$ mole Ca-DTPA/kg from 15 days after mating until the end of pregnancy. In the first litter, 4 pups died soon after birth with gross and histological evidence of brain damage. The only surviving pup showed marked evidence of mental retardation. In the second litter, 2 pups died soon after birth with similar evidence of brain damage; one living pup appears to have hydrocephalus and has grown to only 1/3 of normal body weight; while the remaining 3 pups appear to be grossly normal, although subtle damage may exist. All pups had albino fur at birth, which gradually regained normal color (black, brown, tan, and white) after cessation of Ca-DTPA therapy. No harmful effects were seen in the pregnant adult dogs. The question remains unanswered as to the effect of a single injection of Ca-DTPA on the fetus of a large animal. However, Sikov et al. [8] found that 1 or 2 injections of Ca-DTPA were sufficient to kill the rat fetus. We suggest that Ca-DTPA should not be given to a woman who might be pregnant unless the option of a therapeutic abortion is carefully considered.

### 3. SAFETY OF Zn-DTPA

Because daily injections of 30  $\mu\text{mole Zn-DTPA/kg/day}$  are now in use for the removal of  $^{241}\text{Am}$  from man, it is important to continue testing the safety of repeated administration of this chelating agent. We have observed no toxicity in 5 adult beagles given daily injections of 33 to 360  $\mu\text{mole Zn-DTPA/kg}$  each day continually now for over 3.5 years. In pregnant mice, daily injections of 12,000  $\mu\text{mole Zn-DTPA/kg/day}$  for 5 consecutive days were required to produce demonstrable toxicity to the fetus [10].

### 4. EFFECTIVENESS IN RADIONUCLIDE REMOVAL

We agree with our French [11] and German [12-14] colleagues, that for maximum effectiveness, chelation treatment should start as soon as possible after radionuclide contamination.

Initial chelation of plutonium. We recently injected intravenously 0.1  $\mu\text{Ci/kg}$  of monomeric  $^{239}\text{Pu}$  citrate with traces of photon emitting  $^{237}\text{Pu}$  into 4 groups, each containing 4 young adult beagles. The initial treatment shown in the following tabulation, began 30 minutes after plutonium injection, while the subsequent treatment was 34  $\mu\text{mole Zn-DTPA/kg/day}$ , either in 1 injection per day (groups A, C, and D) or in 5 fractions per day at 4 to 5 hour intervals (group B).

Group	Initial therapy at 30 minutes	$\Sigma$ Pu ret. $\pm$ S.D. at 14 days	
		Total body	Liver
A	30 $\mu\text{mole Ca-DTPA/kg}$	19.1 $\pm$ 3.2	5.4 $\pm$ 1.1
B	300 $\mu\text{mole Zn-DTPA/kg}$	22.7 $\pm$ 4.2	4.3 $\pm$ 1.8
C	300 $\mu\text{mole Zn-DTPA/kg}$	25.7 $\pm$ 3.0	4.7 $\pm$ 2.9
D	34 $\mu\text{mole Zn-DTPA/kg}$	47.9 $\pm$ 2.4	14.7 $\pm$ 3.8
No DTPA, from Stover et al. [15]		87 $\pm$ 2	34 $\pm$ 5

Groups A, B, and C were not statistically different in retention from each other ( $P > 0.2$ ), whereas they were all significantly lower than group D ( $P < 0.01$ ). Either 30  $\mu\text{mole Ca-DTPA/kg}$  or 300  $\mu\text{mole Zn-DTPA/kg}$  provided good initial decorporation (groups A, B, and C), but subsequent therapy every 4 to 5 hours was not significantly better than the same total DTPA injected once each day (group B vs. C).

Protracted chelation of plutonium. Fourteen young adult beagles were injected intravenously with 0.9  $\mu\text{Ci/kg}$  of polymeric  $^{239}\text{Pu}$  to which tracer amounts of photon-emitting  $^{237}\text{Pu}$  had been added at the final stage of the polymerization process. The excretion and distribution results suggest that some of the  $^{237}\text{Pu}$  was metabolized as monomeric Pu and some as polymeric Pu, simulating a mixture of soluble and insoluble plutonium, such as might be encountered in a typical accident. Beginning 2 hours after Pu administration, 4 dogs were given daily injections of about 30  $\mu\text{mole Zn-DTPA/kg}$ , and 4 were given weekly injections of 30  $\mu\text{mole Ca-DTPA/kg}$ , dosages and frequencies that have been used in humans and which have proved safe in beagles. At 64 days later,  $^{237}\text{Pu}$  retention in the liver and non-liver tissue (mainly skeleton) averaged, respectively, 52% and 35% in the untreated dogs; 30% and 18% in the dogs injected weekly with Ca-DTPA; and 20% and 13% in the dogs injected daily with Zn-DTPA [16]. Daily injections of Zn-DTPA were significantly better than weekly injections of Ca-DTPA in chelating Pu and in preventing its translocation to bone.

Chelation of  $^{241}\text{Am}$ . Four young adult beagles were injected intravenously with 0.3  $\mu\text{Ci/kg}$  of monomeric  $^{241}\text{Am}$  in citrate solution. Fourteen days

later, daily administration of 33  $\mu\text{mole Zn-DTPA/kg/day}$  was started.  $^{241}\text{Am}$  retention in the liver decreased from 43% at the start of therapy to 1% at 2 months of chelation, and was undetectable at 1 year. Retention in non-liver tissue (mainly skeleton) decreased from 46% at the start of therapy to 24% at 2 months of chelation to 13% at 1 year, and 7.5% at 3 years. The removal rate was similar whether the daily Zn-DTPA was injected once a day (2 dogs) or in 5 fractions per day (the other 2 dogs). Also, the removal rate was not increased in additional dogs given Zn-DTPA in daily doses 11 and 150 times higher [17]. For treatments started 14 days after  $^{241}\text{Am}$  injection in our beagles, daily doses of 30  $\mu\text{mole/kg/day}$  of Ca-DTPA or Zn-DTPA have proved equally effective in  $^{241}\text{Am}$  removal, although oral zinc and manganese supplements were required to minimize the toxicity of protracted Ca-DTPA therapy.

## 5. DISCUSSION

For initial treatment, DTPA should enter the bloodstream as quickly as possible to intercept the transuranic atoms before they deposit in tissue. It is particularly important to prevent deposition in bone. Ca-DTPA dissociates more readily than Zn-DTPA [1] and, therefore, much more Zn-DTPA than Ca-DTPA is required to provide equal chelation of transuranic elements from the bloodstream. To achieve maximum removal from the body, the initial treatment should be followed by protracted chelation, preferably by Zn-DTPA, because of its safety in repeated administration.  $^{241}\text{Am}$  is normally retained with a biological half-time of about 10 years in the beagle liver [18]. Thus, the rapid removal of  $^{241}\text{Am}$  from the liver by DTPA suggests that the chelation of "firm" deposits takes place mainly within cells rather than in the bloodstream. Only a very small fraction of the DTPA need enter cells for the number of chelate molecules to exceed greatly the available number of transuranic atoms. It is often asserted that water-soluble compounds, such as DTPA, cannot cross the lipid layers of the cell membrane. But we respectfully point out that cells can engulf extracellular material and fluid by the process of pinocytosis. Pinocytosis occurs in all cells, and is particularly active in the phagocytic cells, such as the pulmonary macrophages of the lung, the osteoclasts of the bone, and the Kupffer cells of the liver. Once inside the cell, the DTPA may remain for days. This gives abundant time for the calcium in Ca-DTPA to be replaced by other metals, such as zinc, and this may account for the similarity in effectiveness of Ca-DTPA and Zn-DTPA in the removal of "firm" deposits of transuranic elements from tissue.

## 6. RECOMMENDATIONS FOR HUMAN THERAPY

Chelation therapy is a rapidly moving field, and we expect future advances from new techniques, new drugs, or their combination with DTPA. However, the following, in our opinion, will provide safe and effective therapy for removal of transuranic elements. For the non-pregnant adult, the initial treatment should be 30  $\mu\text{mole Ca-DTPA/kg}$ . Treatment should start as soon as possible after known or suspected contamination, and be given by intravenous injection, subcutaneous injection, or aerosol inhalation --- whichever can be administered most quickly. An alternative initial treatment would be 300  $\mu\text{mole Zn-DTPA/kg}$  injected intravenously. Excreta should be collected every few hours and quickly assayed to derive an estimate of body burden. If additional therapy seems likely to reduce the calculated risk enough to justify the inconvenience of this therapy, daily intravenous (or subcutaneous) injections of 30  $\mu\text{mole Zn-DTPA/kg/day}$  should continue until modification or discontinuation of therapy is appropriate.



## REFERENCES

- (1) Catsch, A., Dekorporierung Radioaktiver und Stabiler Metallionen, Karl Thiemig Verlag, Munich (1968) 25
- (2) Gabard, B., The influence of diethylenetriaminepentaacetate on the synthesis of DNA, RNA, and proteins in the regenerating rat liver, *Biochem. Pharmacol.* 23 (1974) 901
- (3) Taylor, G. N., et al., Increased toxicity of  $\text{Na}_2\text{CaDTP}$  when given by protracted administration, *Health Phys.* 27 (1974) 285
- (4) Planas-Bohne, F., and Lohbreier, J., "Toxicological studies on DTPA", in *Diagnosis and Treatment of Incorporated Radionuclides*, IAEA, Vienna (1976) 505
- (5) Bömer, H., Metabolismus und Toxizität therapeutischer Chelatbildner, *Strahlentherapie* 142 (1971) 349
- (6) Fisher, D. R., et al., Ca-DTPA toxicity in the mouse fetus, *Health Phys.* 29 (1975) 780
- (7) Fisher, D. R., et al., Ca-DTPA-induced fetal death and malformation, *Teratology* 14 (1976) 123
- (8) Sikov, M. R., et al., Teratologic effectiveness and fetal toxicity of DTPA in the rat, *Battelle Pacific Northwest Annual Report BNWL-1950*, Pt. I (1975) 138
- (9) Mays, C. W., et al., Estimated toxicity of Ca-DTPA to the human fetus, *Health Phys.* (1976) 247
- (10) Brummett, E. S. and Mays, C. W., Teratological studies of Zn-DTPA in mice (submitted for publication)
- (11) Pasquier, C. and Ducoussou, R., "Traitement d'urgence des radiocontaminations internes", in *Diagnosis and Treatment of Incorporated Radionuclides*, IAEA, Vienna (1976) 553
- (12) Catsch, A., "Removal of transuranic elements by chelating agents", *ibid.*, p. 295
- (13) Volf, V., "Plutonium decorporation in rats", *ibid.*, p. 307
- (14) Seidel, A., "Removal of  $^{252}\text{Cf}$  and  $^{241}\text{Am}$  from the rat by means of Ca-DTPA and Zn-DTPA", *ibid.*, p. 323
- (15) Stover, B. J., et al., "Retention of  $^{239}\text{Pu(IV)}$  in beagles", in *Radio-biology of Plutonium* (Stover, B. J. and Jee, W. S. S., Eds.) J. W. Press, Univ. of Utah, Salt Lake City (1972) 149
- (16) Lloyd, R. D., et al., Plutonium decorporation in beagles with Ca-DTPA or Zn-DTPA (submitted to *Health Physics*)
- (17) Lloyd, R. D. et al., Decorporation of  $^{241}\text{Am}$  in beagles by DTPA, *Radiat. Res.* 62 (1975) 97
- (18) Lloyd, R. D. et al., Americium studies in beagles, *Health Phys.* 18 (1970) 149

EFFICIENCY OF DECONTAMINATION OF  $^{169}\text{YbCl}_3$  BY DTPA ADMINISTERED  
BY VARIOUS ROUTES AND METHODS IN MICE

A. Naharin  
Soreq Nuclear Research Centre  
Yavne, Israel

### 1. INTRODUCTION

DTPA is known to form, in vivo, a stable complex with heavy metals such as the lanthanides and actinides. DTPA is one of the most efficient chelating agents at our disposal because of the stability of its complexes. Consequently, treatment with DTPA can hasten the clearance or decontamination of many radionuclides from the body. The quickest clearance is achieved when the chelation with DTPA occurs in vitro, or outside the body (99% during the first 24 h)(1). This is not the case for in vivo chelation, or when time elapses between the contamination and the introduction of the chelant. The clearance efficiency of DTPA is inversely proportional to the time lapse (2,3).

The rapid disappearance from the blood of the DTPA complex, although very convenient for diagnostic purposes, may prove less desirable when decontamination is necessary. Thus, the clearance of the contaminant may be more effective when the presence of DTPA in the circulation is prolonged.

The purpose of this work was to find a method of treatment with DTPA which offers more effective decontamination of heavy radioactive metals. The administration of contaminant and DTPA, by different routes and time schedules, was examined in order to determine the availability of DTPA in the biological system and its protective efficiency.

### 2. METHOD

Nine experimental groups of 20 female ICR mice each, were injected with 3  $\mu\text{Ci}/0.02 \text{ mg}/0.1 \text{ ml}$  of  $^{169}\text{YbCl}_3$  and 0.05 mg/0.1 ml DTPA by various routes. Each experimental group was divided into 4 test groups of 5 mice each. One untreated mouse was added to each test group to serve as a control for external contamination. All groups were injected with both the contaminant and DTPA in various combinations of 4 routes of administration:~ intravenous (IV), intraperitoneal (IP), intramuscular (IM) and subcutaneous (SC).

The clearance measurements were carried out by whole body counting on a 3" NaI crystal. To avoid geometrical errors, the animals were pressed gently to the bottom of the counting container. The first body burden reading was taken immediately after injection and then after 2, 6 and 24 hr and after 3, 7, 14 and 28 days. After the last measurement, all animals were sacrificed for distribution studies in the following tissues and organs: blood, spleen, G.I. tract, liver, kidneys, lungs and the remaining carcass. The fur was also measured for external contamination correction.

### 3. RESULTS AND DISCUSSION

Figures 1 and 2 describe the results obtained from the 9 experimental groups. It can be seen that in all groups and control as well, the contaminant is generally eliminated quickest when administered by the IV route. With very few exceptions, the sequence of clearance efficiency was

IV, IP, IM and SC. Figure 1, which demonstrates the dependence of clearance efficiency on time, shows in all 4 routes (a,b,c,d) that the time lapse between contamination and the administration of DTPA is the major factor in the efficiency of decontamination. The removal of the isotope is about ten times more efficient when DTPA is intravenously injected immediately after contamination than when it is administered 24 hr later ((a) 3,6 in Fig. 1). This is well understood as DTPA can pass through the capillaries into the intra-cellular fluid, but is not able to penetrate cells (4).

The highest rate of clearance occurs when DTPA is chelated in vitro with the contaminant (Fig. 2), regardless of the route of administration (a2, b2, c2 and d2). However, as this artificial combination of contaminant and DTPA could not conceivably occur in an actual laboratory accident, these excellent results have no practical bearing and must be regarded only as general knowledge. It can be seen that in all 4 routes, the high rate of elimination drops very quickly during the first hours after DTPA injection and gradually comes to its lower stable rate, after approximately 24 hr.

Group No. 7 provides data on the effect of DTPA administration at the same site as the contamination. Here, the removal rate of the IM injection (c7) is even better than that of the IV injection (a7), as well as the other routes (5). The reason for this can be found in the relatively slower absorption and distribution via the IM route compared with the others, thus creating better in vivo chelating conditions for DTPA.

The results of the preventive experiment (No. 8), where DTPA was administered before  $^{135}\text{YbCl}_3$ , were disappointing. However, this could be partly explained by the rapid chelation of DTPA with calcium, iron (as transferrin) and other minerals in the circulation (6), thus, reducing its availability for chelation with the isotope.

In experiment No. 9, 4 doses of DTPA were injected 2, 6, 24 and 72 h after  $^{135}\text{YbCl}_3$  in all 4 routes. Although, it has already been established that multiple injections of a chelating agent contribute significantly to the removal of the contaminant from the body (2), it can be seen from Fig. 2 that the 4 repetitions of the dose did not succeed in removing the isotope as well as a single dose of DTPA given immediately after the contamination (Fig. 1, a3).

#### REFERENCES

- (1) FOREMAN, H. and HAMILTON, J.B., UCRL-1351 (1951)
- (2) PALMER, H.K., CROOK, G.H. and NELSON, I.C., BNWL-SA-1915 (1968a)
- (3) PALMER, R.E., NELSON, I.C. and CROOK, G.H., Health Phys. 15 (1968) 187
- (4) FOREMAN, H., Metal binding in medicine, Proc. Conf., Philadelphia, Pa. (1958)
- (5) MENOT, J.C. et al., Health Phys. 20 (1971a) 167, ORNL-tr-2491
- (6) TAYLOR, D.M. and SOKBY, F.D., Phys. Med. Biol. 7 (1962) 83

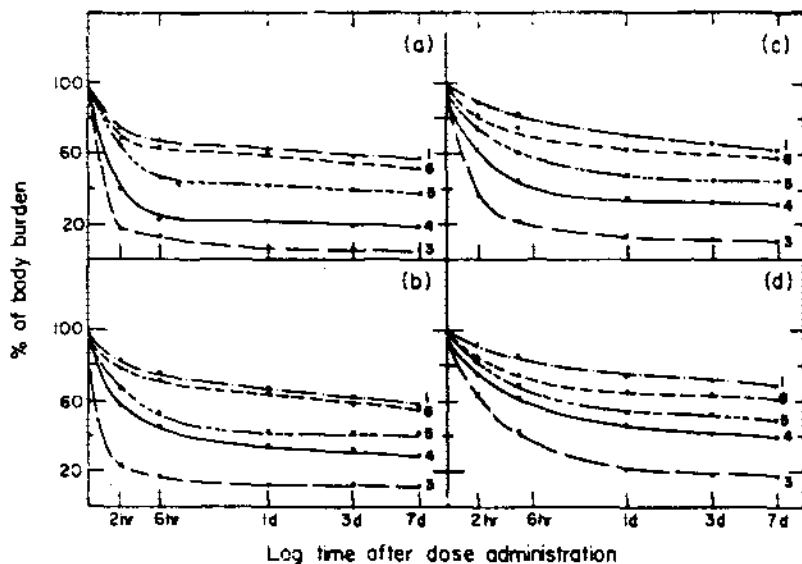

Fig. 1:  $^{169}\text{YbCl}_3$  decontamination efficiency influenced by the time of DTPA treatment in various routes of administration in mice.  
 (a) Intravenous (b) Intraperitoneal (c) Intramuscular  
 (d) Subcutaneous  
 (1) Control,  $^{169}\text{YbCl}_3$  only (2) DTPA treatment immediately after Yb (3) DTPA treatment 15 min. after Yb  
 (4) DTPA treatment 60 min. after Yb (5) DTPA treatment 24 hr. after Yb

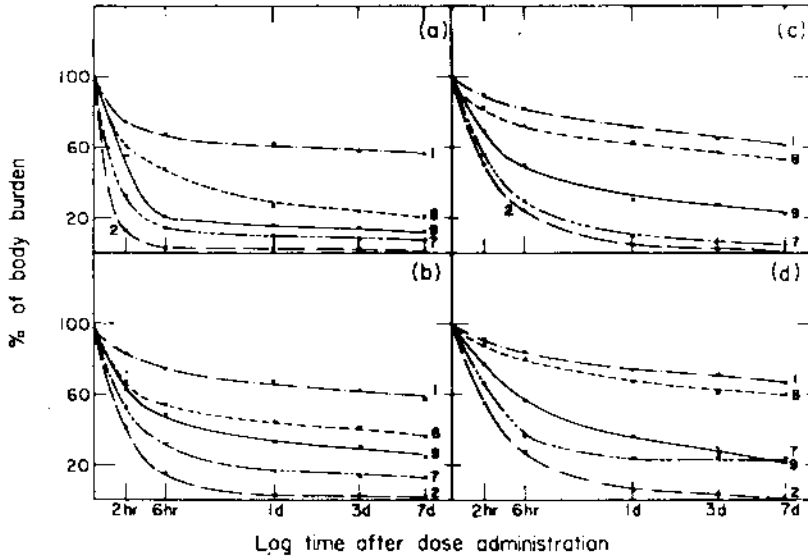

Fig.2: Comparison between the efficiency of several methods of  $^{169}\text{YbCl}_3$  decontamination by DTPA in various routes of administration in mice. (a) Intravenous (b) Intraperitoneal (c) Intramuscular (d) Subcutaneous  
 (1) Control,  $^{169}\text{YbCl}_3$  only (2) Yb + DTPA in vitro  
 (7) DTPA injected in same site as Yb (8) Preventive group, DTPA before Yb (9) Repeated doses of DTPA

REMOVAL OF PLUTONIUM FROM RATS BY PROLONGED ADMINISTRATION OF  
CHELATING AGENTS

W. Volf and E. Gemenetzi

Kernforschungszentrum Karlsruhe, Institut für Strahlenbiologie,  
7500 Karlsruhe, Postfach 3640, Federal Republic of Germany

In our previous work (1) we investigated the effect of single chelate doses and suggested the combination of calcium diethylenetriaminepentaacetate (Ca-DTPA) with desferrioxymine-B methane sulfonate (DFOA) for early decorporation of  $^{239}\text{Pu}$ . The present data concern the efficacy of prolonged chelate administration as a function of the time elapsed since  $^{239}\text{Pu}$  citrate injection, the choice and dosing of chelating agents, and the rate and duration of their administration. Results obtained can be summarized as follows:

1. An early initiated treatment, continued for a month, involving an equivalent of the commonly employed human chelate dose (Tab. 1):
  - 1.1 Prolonged administration of a combination of Ca-DTPA and DFOA was superior to the use of either of these two chelating agents alone.
  - 1.2 The chelate combination could be replaced after the first two injections by zinc diethylenetriaminepentaacetate (Zn-DTPA) without recouction of the overall decorporation effect.
  - 1.3 The first two chelate injections virtually exerted the same effect as prolonged chelate administration; they prevented more than 90 % of injected  $^{239}\text{Pu}$  from deposition in the bone and liver.
  - 1.4 The effect of only one single chelate injection was, however, substantially less, although a chelate combination was injected immediately after  $^{239}\text{Pu}$  incorporation.
2. Treatment initiated 4 days post  $^{239}\text{Pu}$  injection and continued for another 5 days, involving varying amounts of Zn-DTPA (Fig. 1):
  - 2.1 Decorporation of  $^{239}\text{Pu}$  increased with increasing amount of Zn-DTPA; this was most pronounced as far as  $^{239}\text{Pu}$  in the bone is concerned.
  - 2.2 When Zn-DTPA was administered only once a week, the decorporation effectiveness was in general less pronounced than that after the same total weekly chelate dose had been divided into two or more fractions.
  - 2.3 A continuous subcutaneous infusion of Zn-DTPA was in general not more effective than single daily injections of the same chelate amount.
  - 2.4 When the number of Zn-DTPA fractions per week was decreased and, simultaneously, the total chelate dose per week was increased, an equal decorporation effect was achieved.

3. Treatment initiated 4 days post  $^{239}\text{Pu}$  injection and continued for 1 or 4 weeks, involving 5 injections of varying amounts of Zn-DTPA per week
- 3.1 With  $30 \mu\text{mol}\cdot\text{kg}^{-1}$  Zn-DTPA the decorporation of  $^{239}\text{Pu}$  was least pronounced and could be significantly improved by protraction of treatment only as far as  $^{239}\text{Pu}$  in the liver is concerned.
- 3.2 With  $100 \mu\text{mol}\cdot\text{kg}^{-1}$  Zn-DTPA the contents of  $^{239}\text{Pu}$  in the skeleton, liver and kidneys decrease: by 50, 80 and 75 %, respectively, after 4 weeks of treatment, as compared with controls. This is significantly better than the effect of treatment continued for 1 week only.
- 3.3 With  $1000 \mu\text{mol}\cdot\text{kg}^{-1}$  Zn-DTPA the best decorporation results were achieved in the skeleton and liver after one week of treatment. There was surprisingly no further improvement due to protraction of treatment so that after 4 weeks of treatment the  $^{239}\text{Pu}$  removal from the skeleton and kidneys was equal and in the liver even smaller than after administration of  $100 \mu\text{mol}\cdot\text{kg}^{-1}$  Zn-DTPA.

#### CONCLUSION

- a. When a prolonged treatment can be initiated early after  $^{239}\text{Pu}$  incorporation, the effect of the first few injections is most important.
- b. If delays occur, Zn-DTPA becomes the treatment of choice, since it can be administered at higher doses which entail a higher reduction of  $^{239}\text{Pu}$  contents in the organs than can be obtained by the human Ca-DTPA dose.
- c. A sufficiently long period of administration and fractioning of the weekly, rather than of the daily Zn-DTPA dose seem to be the most important factors influencing the effectiveness of a delayed prolonged chelate treatment of incorporated  $^{239}\text{Pu}$ .

#### REFERENCE

- (1) VOLFF, V., "Diagnosis and Treatment of Incorporated Radionuclides" IAEA, Vienna (1976), p. 307.

Treatment schedule <sup>a</sup>		N	Percentage of injected <sup>239</sup> Pu dose <sup>b</sup>		
Injection 1-2	Injection 3-6		Skeleton	Liver	Kidneys
Controls		24	50.6 ± 0.9	4.0 ± 0.1	0.35 ± 0.01
Ca-DTPA	Ca-DTPA	6	11.0 ± 2.7	0.49 ± 0.08	0.061 ± 0.009
DFOA	Zn-DTPA	6	5.4 ± 1.7	0.67 ± 0.08	0.13 ± 0.01
Ca-DTPA+DFOA	Ca-DTPA+DFOA	6	3.6 ± 0.5	0.41 ± 0.03	0.070 ± 0.010
Ca-DTPA+DFOA	Zn-DTPA	6	3.3 ± 0.4	0.27 ± 0.01	0.050 ± 0.010
Controls		14	57.7 ± 1.7	4.1 ± 0.1	0.33 ± 0.0*
Ca-DTPA+DFOA <sup>c</sup>	-	6	3.2 ± 0.4	0.36 ± 0.02	0.10 ± 0.0*
Ca-DTPA+DFOA <sup>d</sup>	-	10	7.7 ± 1.1	0.55 ± 0.06	0.15 ± 0.02

TABLE 1. Organ retention of <sup>239</sup>Pu affected by repeated administration of chelating agents, beginning early after <sup>239</sup>Pu incorporation.

<sup>a</sup> Chelating agents (30 μmol·kg<sup>-1</sup> each) were injected i.p. at 1.5 min and on days 1, 8, 15, 22 and 29 after i.v. injection of <sup>239</sup>Pu citrate. Rats were sacrificed 36 days after <sup>239</sup>Pu administration.

<sup>b</sup> Arithmetic means ± S.E.; N - number of animals

<sup>c</sup> Only two chelate injections, at 1.5 min and on day 1 post <sup>239</sup>Pu

<sup>d</sup> Only one chelate injection, at 1.5 min post <sup>239</sup>Pu



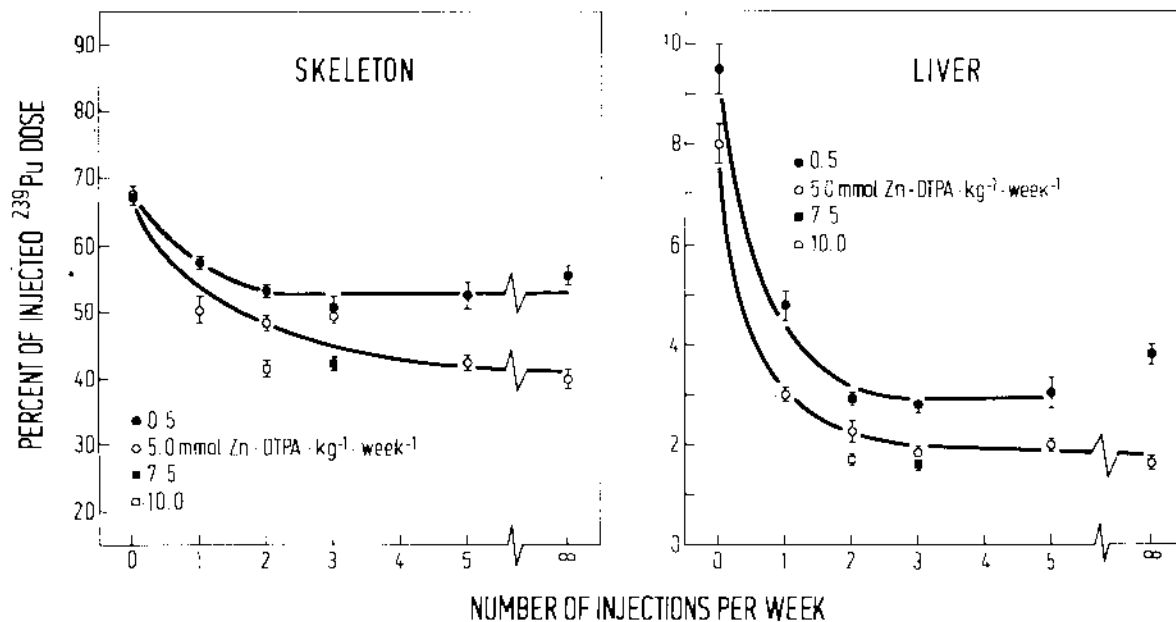

Fig. 1. Organ retention of  $^{239}\text{Pu}$  as a function of the total Zn-DTPA dose and its fractioning. Zn-DTPA was injected or infused s.c. on days 5 to 9 after i.v. injection of  $^{239}\text{Pu}$  citrate. Rats were sacrificed 15 days after  $^{239}\text{Pu}$  administration. Values are geometric means  $\pm$  S.E., on the average 6 rats per group.

EFFECT OF DECONTAMINATION TREATMENT IN PROPHYLAXIS  
OF IRRADIATION AT CONDITIONS OF RADIOCONTAMINATION  
OF NORMAL AND DAMAGED SKIN

K.Milivojević, D.Stojanović, P.Marković\*  
A.Živanović and J.Stajić

Medical Protection Laboratory of the  
Boris Kidrič Institute of Nuclear  
Sciences, Vinča-Belgrade, Yugoslavia

\*Radiation Protection Laboratory IBK and  
Physics Department University of Kragujevac

## 1. INTRODUCTION

The main goal of an adequate decontamination treatment for different types of contamination, is to prevent or decrease harmful effects of radionuclides on tissues, systems and organism. In this paper the decontamination efficiency of normal and damaged skin, contaminated with  $^{137}\text{Cs}$  is studied by estimating the absorbed doses from beta radiation after performed decontamination. The contribute to the absorbed dose from gamma radiation was neglected in this study.

## 2. EXPERIMENTAL

White male rats weighing about 200 g were used. Number of animals in each group was 20. During the experiment the animals were in narcosis with urethane or ether. Conditions of damage: Thermal burn was made on shawed skin between scapulae by use of Deshevy thermocautery at temperature of  $600^{\circ}\text{C}$ . The circular area after burn was two  $\text{cm}^2$  and together with immediate neighborhood represented 1% of the whole surface of the rats skin. On the shawed skin between scapulae a full thickness of the skin, 8 mm in diameter was excised with a special circular perforator. Conditions of contaminations: On normal skin and damaged skin  $40 \mu\text{Ci } ^{137}\text{CsCl}$  was applied. Decontamination treatment was applied 10 and 30 minutes and one hour and the method was based on rinsing with means for decontamination. Techniques of measurement: Quantities of the absorbed radiocesium was measured directly by a modified scintillation counter for small experimental animals.

The dose rate at the moment where decontamination was performed, taken to be  $t = 0$ , was calculated by using the following formula(1):

$$D = 2,13 \cdot \bar{E} \cdot A \text{ rad/h.}$$

The integral absorbed dose for some time  $t$  afterwards was obtained from the expression(1):

$$D = 73,8 \cdot \bar{E}_\beta \cdot A_0 \cdot T(1 - \exp \frac{-0,693 t}{T}) \text{ rad}$$

where  $T_{\text{eff}}$  is the effective half time of elimination, to for rats taken to be: 5,7 days for body(2) and, one day for skin(3)  
 $\bar{E}_\beta$  - the average energy of the beta radiation and  $A_0$ -specific activity at  $t = 0$ .

### 3. RESULTS AND DISCUSSION

Efficiency of decontamination evaluated on total body burden of radiocesium and residual radioactivity in the decontaminated region is given in table 1.

Absorp- tive area	Time of contact (min)	Means	A c t i v i t y		Efficiency decontami- nation
			body	local	
Normal skin	60	Untreated	1,33±0,21	98,67±0,21	-
		Water	1,42±0,65	6,20±1,38	92,38±2,03
		Deterg.Badd	2,02±1,02	1,03±0,31	96,95±1,33
Excised Skin	10	Water	54,70±6,90	6,91±1,46	38,39±6,90
		Saline	55,91±7,17	5,49±1,19	38,60±7,17
	30	Water	86,08±2,77	7,76±2,08	6,16±2,77
		Saline	79,92±6,18	5,18±0,74	14,90±6,18
Thermal burn	30	Untreated	21,12±4,61	78,88±4,61	-
		Water	28,31±8,03	32,78±6,30	38,91±8,03
		1% soap	27,57±6,78	36,83±8,99	36,60±8,99

TABLE 1 Effect of external decontamination, in per cent of radioactivity applied (Contamination with  $^{137}\text{CsCl}$ ).

The calculated doses as a function of the contamination duration, the means used for decontamination and other parameters is given in table 2.

Absorptive area	Time of contact (min)	Means for decontamination	Time after decont. (days)	Doses in rads body(g) local	
Normal skin	60	Untreated	t = 0	0,001	7,2
			1	0,020	125,6
			30	0,190	251,2
		Water	t = 0	0,001	0,5
			1	0,023	7,9
			30	0,201	15,8
		Detergent Badd	t = 0	0,002	0,1
			1	0,034	1,3
			30	0,285	2,6
Skin wound	10	Water	t = 0	0,1	0,7
			1	1,4	
			30	11,6	
	Saline	t = 0	0,1	0,5	
		1	1,4		
		30	11,6		
	30	Water	t = 0	0,1	0,8
			1	2,1	
			30	17,7	
Saline	t = 0	0,1	0,5		
	1	1,9			
	30	16,0			
Thermal burn	30	Untreated	t = 0	0,02	7,7
			1	0,47	
			30	3,98	
		Water	t = 0	0,03	3,2
			1	0,63	
			30	5,34	
		1% soap	t = 0	0,03	3,6
			1	0,61	
			30	5,20	

TABLE 2 Absorbed beta doses in cases of external decontamination (Contamination with  $^{137}\text{CsCl}$  ).

These results were obtained by assuming the uniform distribution of radiocesium an approximation accepted in radiotoxicology. On table 3 is given the distribution of radiocesium and calculated beta doses.

Tissues and organs	Specific activity ( $\mu\text{Ci/g}$ )	Doses in rads	
		t=0	t = 30 d
Blood	0,0153	1,4	1,4
Muscles	0,0333	3,2	3,1
Heart	0,2784	27,0	26,2
Kidneys	0,3320	32,4	31,3
Liver	0,1707	16,5	16,1
Spleen	0,1473	14,3	13,9

TABLE 3 Distribution of radiocesium and absorbed beta doses/g of fresh tissue.

Our experimental results, given in table 3, show that the above approximation might be too crude, and that it might be necessary to estimate doses and corresponding risks, separately for different organs and tissues. The work on the risk estimate, including radiopathological states and radiosensitivity of different tissues, is underway.

#### REFERENCES

- (1) NEWBERY, G.R., Proc. of Symp. Atomic Energy Establishment, Winfrith, 1963, 44.
- (2) BULDAKOV, L.A., MOSKALEV, J.I., Problemi raspredelenija i eksperimentalnoj ocenki dopustimih urovnei  $^{137}\text{Cs}$ ,  $^{90}\text{Sr}$  i  $^{106}\text{Ru}$ , Gos. Atomizdat, Moskva (1968).
- (3) Personal data.

## A MICROPROCESSOR CONTROLLED TL DOSIMETRY SYSTEM

E.F. Shrader, B.M. Shoffner, A. Szalanczy, and J. Chamberlain  
Harshaw Chemical Company, Solon, Ohio U.S.A. 44139

## 1. INTRODUCTION

The use of thermoluminescent dosimetry for personnel radiation monitoring has in the past few years gained increasing acceptance. The application of thermoluminescent dosimetry (and its limitations) is well known. The increase of its use has now placed the burden on the technology of deployment of the technique. When large numbers of people are to be served these problems now become of paramount importance. The deployment, retrieval, evaluation and recording of data must be easy, reliable, accurate and inexpensive. The first commercially available automatic system was the Harshaw Model 2271 (1) introduced in 1971. Since its introduction it has achieved wide acceptance. In this system the TL material was not handled directly but instead was carried in a reusable vehicle (card) as a direct replacement for the packaged dosimetry films. The reading instrument identified the card and measured the TL response as cards were automatically loaded from the cartridge into the reading instrument. The choice of a limited number of parameters was provided the operator in the form of front panel switches and knobs. The Model 2276 TLD System shown in Fig. 1 is a second generation automatic system embodying much of the earlier technology but extending the versatility of the earlier system in a manner to be described.

## 2. TL DOSIMETER DESCRIPTION

As many as four TL dosimeters are mounted in a card shown in Fig. 2. The TL materials are the choice of the user at time of card construction. The TL materials are encapsulated between teflon films approximately 0.04mm thick. This combination when suitably filtered provides for measurement of penetrating and nonpenetrating gamma radiation and by differences, slow neutrons. The card carries a machine-readable bar code identification\* together with its Arabic numeral equivalent.

## 3. MODEL 2276 SYSTEM DESCRIPTION

The Model 2276 system shown in Fig. 1 consists basically of three components, the Model 2276T Transport Module, the Model 2276L Logic Module and the Model 2000B Integrating Picoammeter. The system is capable of performing five sequential functions when appropriately programmed; (1) loading a card into the transport module from a cartridge (2) exposing each dosimeter to a known amount of radiation (3) subjecting each dosimeter to an initial heat cycle (4) subjecting each dosimeter to a readout heat cycle and finally (5) discharging the card into a receiving cartridge. As shown in Fig. 3 the transport mechanism, here shown open, consists of a large circular table into which are set six card carriers. Using a Geneva movement each card carrier can be carried into six successive positions; one for each of the five above functions plus one additional for manual loading and unloading of cards. Each card carrier itself can be rotated through six positions by means of a second Geneva movement and planetary gear arrangement. Four of the six positions correspond to proper placement of each of the four dosimeters. The remaining two positions are

\*The bar code is known as CODABAR, a product of Monarch Marking Systems, Pitney Bowes



Figure 1 The Model 2276 Dosimetry System

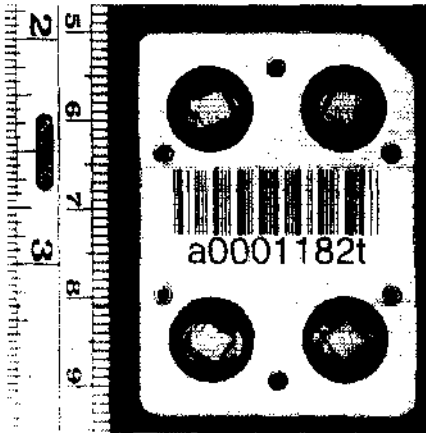

Figure 2 The 2276 Dosimeter Card

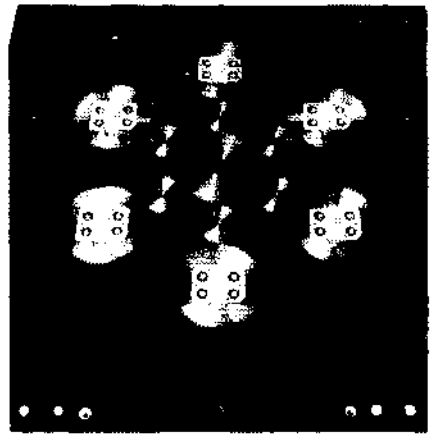

Figure 3 The Card Transport Mechanism

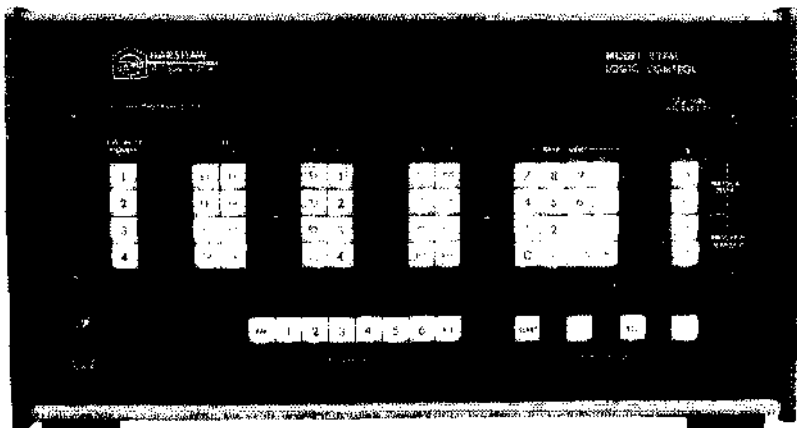

Figure 4 The 2276L Control Panel

passed through i.e., not used. In position #1 of the table a card from the cartridge is transferred to the carrier. In traveling from position #1 to position #2 the card identification is optically scanned and decoded. In position #2 the desired dosimeters can be given a programmable radiation exposure. Position #3 is provided with a "hot finger" so that, if desired, a pre-read heat cycle can be applied e.g. to empty low temperature TL traps. Position #4 is equipped with a "hot finger" and phototube so that the TL can be measured. In position #5 the mechanism lifts the card from the carrier and inserts it into the receiver. Position #6 at the front of the instrument provides for manually loading and unloading cards from the carrier.

All motions are motor driven and monitored by optical sensors. There are sufficient "hardwired" logic interlocks in the Transport Module to prevent mechanical damage but otherwise all operations are controlled by the Logic Module acting on sensor indications of system status.

#### 4. SYSTEM OPERATION

The Model 2276L Logic Module is a microprocessor (16 bit) based system which allows great flexibility in system operation including remote programming from another computer. The control panel of the Module is shown in Fig. 4. The "Program Control" keys allow the selection of the dosimeters to be processed and the sequence of operations to be followed. The LED associated with each key indicates the operational status. The LED associated with the dosimeter currently being processed blinks on and off. The cycle functions which can be selected are EX (expose the dosimeter), PR (preheat the dosimeter), RD (read the dosimeter) and TR (unload the card and transmit the information). A second cycle is provided if it is desired to calibrate the card after a normal readout cycle without removing the card from instrument. Numerical information concerning the status of the system is shown in the LED numerical display. The I.D. of the card in any one of the four positions will be displayed by pushing the appropriate key in the DATA SELECT column labeled I.D.

The parameters of the functions EX, PR and RD can be selected by the operator. The available EX (expose) function parameter is the time duration of the exposure of the card to the radiation source. There are two parameters for the PR (preheat) function. They are the temperature and the time duration.

The parameters of the RD (read) function describe the time vs temperature cycle to which the dosimeter is subjected. The temperature rises rapidly to an initial value  $T_{INIT}$  then increases linearly with time at a rate,  $T_{RT}$  until the temperature reaches a temperature  $T_{MAX}$  at which value the temperature is held constant until the end of cycle (12 seconds in duration). The value of each parameter can be displayed by pushing the appropriate TIME or TEMP key in the DATA SELECT bank. It is possible to enter a new value for any particular parameter in the following manner; display the parameter to be changed; put the instrument in Panel Mode by pushing the PAN key of the PROGRAM SELECT bank; choose the new value by keying it in from the DATA ENTRY numerical keyboard (this value will be displayed) followed by pushing the ENTER key. It is possible to store up to six programs by pushing first the store program (SP) key followed by one of the Program Select keys. There is built into the instrument a representative program which may be recalled by pushing the NORM key of the Program Select bank. The stored programs may not be recalled or parameters changed when the system is in START mode, i.e., is processing dosimeters.



Having selected the operating program the system is started by pushing the System Control START key. The system automatically initializes itself and begins loading cards from the cartridge when the cycle sequence is begun. When the card is unloaded the I.D. and associated TL data is transmitted to an output device (TTY) or computer via an EIA RS-232C compatible link. The sequence may be stopped by pushing the STOP key which causes the loading to cease but continues operating until the instrument is emptied of cards. The operation of the STOP key results in stopping the instrument immediately after the heat cycle in progress while the operation of the HOLD key stops the operation after completion of function in progress for all dosimeters on a card. There are performance tests available. The operation of the Background (BG) key will integrate the dark current for the Read cycle without a card present. The Sensitivity key (SENS) permits integration of phototube current excited by light from an internal radioactively stimulated phosphor. The operating cycle sequence and parameters may be transmitted to an output device by operating the IF key of the Program Transfer group.

## 5. SYSTEM PERFORMANCE

A low background is achieved by using a thermoelectrically cooled photomultiplier which is in close optical coupling with the TL dosimeter. A typical background is 500mR exposure equivalent. The reproducibility of the TL reading for a given dosimeter exposed to 100mR is approximately 1.0% (standard deviation). The throughput is 60 cards/hour reading all four dosimeters (assuming the read function is the rate limiting factor).

Table 1 is a typical data output format and Table 2 is the program output format.

TABLE 1 DATA OUTPUT FORMAT

000009592	1=1309	1	2=1186	1	3=0766	1	4=0747	1
000006441	1=0687	1	2=0757	1	3=0941	1	4=0648	1
000008793	1=1078	1	2=1137	1	3=0733	1	4=0631	1

The first column in Table 1 is the card identification number followed by the response of each dosimeter (four digits plus a range digit).

TABLE 2 PROGRAM OUTPUT FORMAT

```
DS=1234. C1=PRT. C2=. AUX 1=000 2=000 3=000 4=000
TIME EX=10.0 PR=10.0 R1=01.0 R2=10.0
TEMP PR=100 INTT=250 RT=30.0 MAX=300
```

In Table 2 the dosimeters to be read are listed together with the cycle sequence. The parameters labeled AUX are reserved for special options. The temperatures are in degrees celsius and the times in seconds.

(1) Cox, F.M., Lucas, A., Health Physics, Pergamon Press 27, 339 (1974)

PRELIMINARY RESULTS ON THE USE OF A HIGH OUTPUT AUTOMATIC  
READER FOR PERSONAL RADIOTHERMOLUMINESCENT DOSIMETERS

G. PORTAL - R. PRIGENT - Ph. BLANCHARD - R. CHENAULT

COMMISSARIAT A L'ENERGIE ATOMIQUE  
Département de Protection  
Service Technique d'Etudes de Protection  
Section Technique d'Instrumentation et de Dosimétrie  
Centre d'Etudes Nucléaires de Fontenay-aux-Roses - France

A new automatic reader for TL personal dosimeters has been recently constructed in our laboratory. It is a very fast model, able to read 10 complete badges in one minute. It is linked to a mini-computer to improve the accuracy of the measurements and to obtain an instantaneous processing of the information. This reader is described and performances are given.

### 1. THE INDIVIDUAL DOSIMETER PGP 1 (fig. 1)

The dosimeter comprises :           1) sensitive elements  
  2) a box  
and :                                   3) a drawer.

#### 1.1. The sensitive elements

We have chosen magnesium activated lithium fluoride containing Na as stabilizing element. This TL material has been previously studied in our laboratory (1). Due to the absence of intermediate energy traps, this special kind of LiF can be reused without regeneration if preheating treatment is used to empty the low temperature traps. Under these conditions such a phosphor can be adopted for large scale monitoring without any difficulty.

LiF-Mg (Na) is pressed in the form of small discs (diameter 4.5 mm - thickness 0.8 mm) containing no binding agent (2).

The dosimeter can be equipped with :

- two sensitive elements for non-discriminating detection (3)

or : - four sensitive elements for discriminating detection.

#### 1.2. The Drawer

This is the conveyor system. It is designed to keep the pellets in the box during use, and to move them to various working positions during the readings. It consists of a light metal strip with four holes in which the pellets are placed. The drawer is inserted through a slit at one end of the box.

#### 1.3. The box

Contains different filters :

- 20 mg.cm <sup>-2</sup> of polyethylene or paper	(determination of skin dose)
- 320 mg.cm <sup>-2</sup> of plastic	(determination of body dose)
- 1 mm of copper	} energy and incidence determination
- 1 mm of lead	

The two first filters are used to determine skin and body doses; the two remaining filters furnish information on :

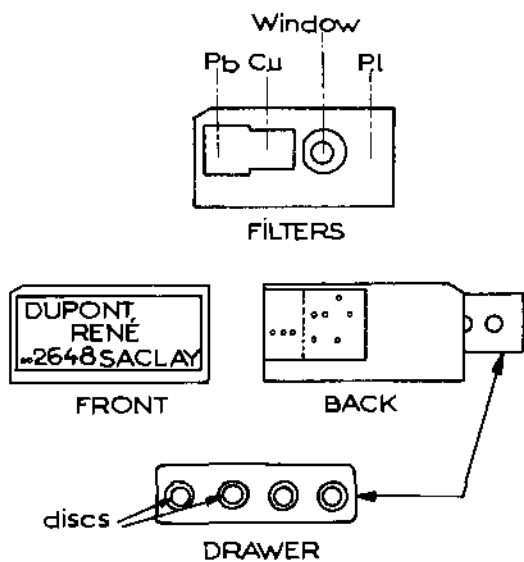

FIG 1  
TL DOSIMETER PGP<sub>1</sub>

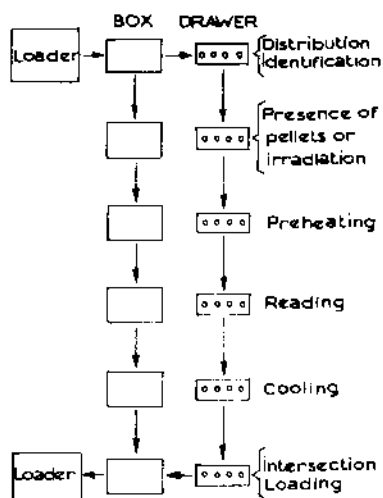

FIG 2  
Operations in the reader

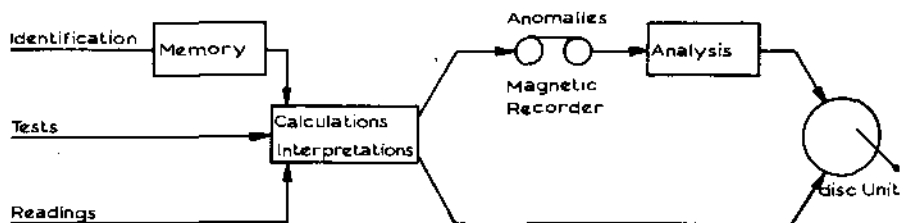

FIG 3  
Information treatments

Identification	(X+γ)dose	(B+X+γ)dose	Th.Ndose	Tests		
				Presence	Heating	Voltage
387839	000225	000390	000000	+++	+++	+++
122543	000050	000050	000000	+++	+-	+++

FIG 4  
Results

- the thermal neutron dose ( $^{7}\text{LiF}$  pellet)
  - the energy of X rays
- and : - an estimation of incidence of irradiation.

## 2. THE READER (fig. 2)

### 2.1. Operations

It is a fully automatic system. The badges, stored in a loader, are fed, one every 6 seconds, onto a mechanical conveyor assembly which carries out the following operations :

- extraction of the drawer and reading of identification,
- verification of the presence of the detectors (or irradiation),
- preheating on a hot plate kept at a constant temperature of 160°C,
- heating on a hot plate kept at a temperature of 260°C and reading,
- cooling of the pellets,
- insertion of the drawer into the box,
- stacking of boxes in another loader to facilitate their storage.

### 2.2. Heating

To obtain fast readings constant temperature heating systems have been chosen for the preheating and heating stages. The four pellets are heated at the same time. If required only two pellets can be read, the two others being used for integration.

### 2.3. Reading

The four detectors are read at the same time by four photomultipliers equipped with four light guides water cooled.

## 3. INFORMATION TREATMENT (fig. 3)

### 3.1. Individual sensitivity correction

The automatic reader can be equipped with beta  $^{90}(\text{Sr} + \text{Y})$  sources to check the individual sensitivity of the pellets; this information is stored in the memory of the mini-computer. When reading the dosimeters, the computer takes into account the individual sensitivity of each element. Such a system improves the accuracy of the measurements and lowers the price of the detectors for it suppresses selection for the manufacturer.

### 3.2. Tests

The reader itself tests the following parameters :

- presence of four pellets,
- heating temperature,
- low and high voltage.

### 3.3. Results (fig. 4)

After reading and interpretation, the results are normally stored on a disc Unit. If the computer detects some defects or anomalies, the corresponding results are stored on a magnetic recorder and they must be analysed by an operator before storage in the disc unit. The results of the tests are reported in a document which is then sent to the customer. With these controls, consultation of the document provides complete assurance that measurements have been carried out in good conditions. An example of this document is given in fig. 4.

### 3.4. Performances

This automatic reader has recently been made operational, and we provide below only a first evaluation of its performances :

- speed of reading : 10 dosimeters in a minute
- reproducibility :  $\pm 3$  p.cent
- minimum detectable dose : 10 mrad  $\pm 3$  mrad
- maximum detectable dose : 1 000 rads
- reuse of the badges : about 50 times before recalibration  
: 200 to 300 total reuse.

This automatic reader will be used, in the near future, for large scale routine dosimetry of people not directly involved in work associated with radioactive risks.

It can be used also for environmental measurements with different adjustments. In this condition the minimum detectable dose corresponds to :  
1 mrad  $\pm$  0.5 mrad.

### REFERENCES

- (1) PORTAL, G., BLANCHARD, Ph., TRIGENT, R., CHENAULT, R., "Automatic Rapid Reading System for TL Personal dosimeters", IV Intern. Conf. Lumin. Dosimetry, Krakov, Poland, 27-31 Août 1974
- (2) Obtained from DESMARQUEST et C.E.C.. Z.I. 1, 27 000 EVREUX, FRANCE
- (3) "Technical recommendations for the use of TL dosimetry....."C.C.E. Radioprotection-3, EUR 5 358, 1976

## THE RESPONSE OF SOME THERMOLUMINESCENT MATERIALS TO NEUTRONS

R. MEDIONI\* - G. PESCAVRE\*\* - F. SPURNY\*\*\* - G. PORTAL\*

\* Département de Protection, STEP/STTD, Commissariat à l'Énergie Atomique

B.P. N° 6 - 92260 FONTENAY-aux-ROSES - France

\*\* S.P.R. - Centre de VALDUC - B.P. 14 - 21120 IS-sur-TILLE - France

\*\*\* Radiation Dosimetry Institut, Czechoslovak Academy of Sciences, PRAGUE

## 1. INTRODUCTION

Thermoluminescent materials are very often used for gamma dosimetry. However, they exhibit a response to neutrons and in mixed fields therefore, the results given by these dosimeters must be corrected.

This correction is a function of the detector, of its environment and varies with the neutron energy ( $E_n$ ). We present here the results obtained recently in our laboratory for monoenergetic neutrons and compare with those those we obtained with polyenergetic neutrons (1).

## 2. NEUTRON SOURCES AND DETECTORS STUDIED

## 2.1. Neutron sources

- polyenergetic sources :
  - thermal neutrons (pool reactor TRITON)
  - Pu-Be source (10 Ci)
  - $^{252}\text{Cf}$  source.

The fluence rate of these sources has been determined by activation measurements or by the manganese bath method.

- monoenergetic neutrons :

Experiments were carried out near a number of installations : Van de Graaff generators (5 MeV at Cadarache (Cad), 4 MeV at Bruyères-le-Châtel (D 3) and 3 MeV at the G.S.F. in Munich (G.S.F.)), the neutron generator of the R.D.I. in Prague (R.D.I.) and the SAMES accelerator of STEP at Fontenay-aux-Roses (F.A.R.).

In the first two cases the neutron fluence has been determined with the aid of a directional counter; the energy and fluence at the irradiation point have been recalculated according to known data (2), (3). At Prague the reaction  $^{56}\text{Fe}(n,p)^{56}\text{Mn}$  has been used. For calculating the kerma value we have referred to (4).

The irradiations at Munich were made during the ENDIP experiments organized in 1975 by EURATOM and the neutron doses considered here are the preliminary results obtained by the Munich team (5)(6). At Fontenay many methods have been used, among others a T.E. chamber.

## 2.2. Thermoluminescent detectors studied

These were powdered forms of the following :

- $\text{CaSO}_4$  : Dy
- $^7\text{LiF}$  : Mg (99,95 %  $^7\text{Li}$ )
- nat $^6\text{LiF}$  : Mg
- $\text{Al}_2\text{O}_3$

$E_n$ (MeV)	Place	$\text{CaSO}_4$		$^7\text{LiF}$		$\text{natLiF}$		$\text{Al}_2\text{O}_3$	
		PI	AI	PI	AI	PI	AI	PI	AI
0.252	Cad			$1.3 \pm 0.4$	$0.9 \pm 0.3$	$6.1 \pm 0.8$	$5.9 \pm 0.6$		
0.350	"					$5.9 \pm 1.6$	$6.2 \pm 1.8$		
0.716	"	$0.5 \pm 0.2$	$0.2 \pm 0.1$	$1.6 \pm 0.2$	$1.2 \pm 0.3$	$3.0 \pm 0.4$	$1.6 \pm 0.2$		
1.4	B 3			$0.9 \pm 0.1$	$0.8 \pm 0.1$	$1.7 \pm 0.2$	$1.7 \pm 0.2$	$0.9 \pm 0.2$	$0.8 \pm 0.1$
2.1	GSF		$0.4 \pm 0.2$	$1.4 \pm 0.3$	$1.5 \pm 0.4$	$2.1 \pm 0.4$	$2.3 \pm 0.5$		
2.2	Cad	$1.5 \pm 0.2$	$0.4 \pm 0.1$	$2.2 \pm 0.3$	$1.3 \pm 0.4$	$2.5 \pm 0.4$	$1.7 \pm 0.3$		
3	B 3	$1.8 \pm 0.3$		$2.3 \pm 0.3$		$2.2 \pm 0.5$		$1.8 \pm 0.3$	
3.3	FAR	$1.8 \pm 0.3$	$1.1 \pm 0.2$	$2.1 \pm 0.3$	$1.5 \pm 0.3$	$2.8 \pm 0.3$	$1.9 \pm 0.2$	$1.9 \pm 0.4$	$1.1 \pm 0.3$
5.25	GSF	$5.1 \pm 1.3$	$3.3 \pm 1.0$	$3.9 \pm 1.2$	$2.9 \pm 1.1$	$4.3 \pm 1.3$	$2.4 \pm 0.9$	$5.0 \pm 2.5$	$2.2 \pm 0.9$
7	B 3	$7.3 \pm 1.7$	$3.0 \pm 1.4$	$7.3 \pm 1.3$	$3.6 \pm 1.8$	$7.5 \pm 1.5$	$3.0 \pm 1.1$	$7.5 \pm 1.4$	$2.5 \pm 1.1$
14.7	RDI	$24.2 \pm 1.2$	$9.8 \pm 0.8$	$25.2 \pm 1.2$	$10.2 \pm 0.5$	$32.6 \pm 2.3$	$13.5 \pm 0.4$	$37.6 \pm 2.3$	$17.1 \pm 0.5$
15.1	GSF	$27.6 \pm 2.9$	$10.4 \pm 1.4$	$25.3 \pm 3.3$	$10.6 \pm 1.6$	$28.6 \pm 3.2$	$11.2 \pm 1.4$	$38.6 \pm 4.1$	$19.8 \pm 2.0$
$^{252}\text{Cf}$	FAR	$3.1 \pm 2.4$	$1.1 \pm 1.4$ $- 1.1$	$5.3 \pm 0.9$	$2.6 \pm 1.4$	$9.3 \pm 1.7$	$5.7 \pm 1.4$	$3.4 \pm 0.8$	$1.3 \pm 1.4$ $- 1.3$
PuBe	"	5.6	$3.3 \pm 1.4$	6.4	$5.6 \pm 1.4$	8.7	$7.5 \pm 1.4$	5.4	$1.1 \pm 1.4$ $- 1.1$
* 1h	"		$2.1 \pm 2.8$ $- 2.1$		$8.8 \pm 1.4$		$1580 \pm 140$		$1.7 \pm 1.3$

\* For thermal neutrons the tabulated value is k.

TABLE 1 - RELATIVE RESPONSE OF TLDs TO NEUTRONS ( $k \times 10^{-2}$ )\*

They were irradiated in polyethylene tubes (3.9 mm internal diam.; wall thickness 1.1 mm; referred to as P1) and aluminium tubes (3.1 mm internal diam.; wall thickness 0.9 mm; referred to as A1).

### 2.3. Dosimeter evaluation

The detectors are evaluated using a LDT 20 (Saphymo Strat) reader standardized in our laboratory using a  $^{60}\text{Co}$  source. The emitted signal is translated in terms of dose of gamma  $^{60}\text{Co}$  in a unit tissue volume.

### 2.4. Gamma exposure measurements

Two methods have been used to determine the gamma exposure associated with the neutron beam at the irradiation point.

- photographic emulsion : according to the method described by Bewley (7) the emulsion is enclosed in a lead sheath.
- Geiger-Muller counter (Philips 18509) under tin and lead shields (8) with an additional  $^6\text{LiF}$  shield.

The neutron response of these dosimeters is very slight and has been considered here as negligible.

## 3. THERMOLUMINESCENT DOSIMETER NEUTRON RESPONSE.

### 3.1. Results

We define the relative response (k) by :  $k = \frac{L - X}{D_N}$

where L is the dosimeter reading, X is the dose in a unit tissue volume due to gamma only,  $D_N$  is the neutron dose (tissue kerma) and k expresses the neutron response in terms of gamma  $^{60}\text{Co}$ .

Table 1 presents the results obtained. The powders irradiated under aluminium yield results approaching the intrinsic response. However the relative response obtained under polyethylene more closely represents current practice.

### 3.2. Discussion

In general, the relative response of TLD's increases with the neutron energy ( $E_n$ ); the calculated kerma values for the same materials show a similar trend. Comparison of these two results enables interesting conclusions to be drawn regarding the thermoluminescent yield (9).

In the case  $E_n < 3$  MeV the intrinsic responses are inferior to 0.02. All the detectors, except of course  $\text{natLiF}$ , can therefore be used for gamma measurements in a mixed field almost without correction. For higher energies and polyenergetic sources (Cf, Pu-Be) corrections are necessary and become increasingly important with increasing values of  $E_n$ . This trend is most marked in  $\text{Al}_2\text{O}_3$  and has suggested an application (10) for total dose measurements in mixed gamma and 14.7 MeV neutron fields.

Table 1 also shows that the influence of recoil protons (i.e. the difference between the responses obtained using the polyethylene and aluminium containers) is not negligible especially for high values of  $E_n$ . In this case therefore, it would be desirable to use non-hydrogenous containers.

---

The authors acknowledge that this study has been partly sponsored by EURATOM contract N° 065-72-01-PSTC.



#### REFERENCES

- (1) SPURNY, F., MEDIONI, R., PORTAL, G., "Proc. 2nd Symp. on Neutron dosimetry in biology and medicine" (BURGER, G., Ed; EUR 5273 d-e-f, EURATOM 1975) vol. 1, p. 495.
- (2) Nuclear Data Tables. Volume 11, Number 7, June 1973. Academic Press New-York.
- (3) Atomic Data and Nuclear Data Tables. Volume 15, Number 1, January 1975. Academic Press New-York.
- (4) ICRU Report 13, Neutron fluence, spectra and kerma (ICRU, Washington 1969).
- (5) SCHRAUDE, H., MORHART, A., SCHRAUDE, G., BURGER, G. "Basic Physical data for neutron dosimetry" EUR 5629e (1976) 243.
- (6) BURGER, G., GSF MUNICH. Private communication (1976).
- (7) BLUM, E., BEWLEY, D.K., HEATHER, J.D., Phys. Med. Biol. 18 (1973) 226.
- (8) WAGNER, F.B., HURTS, G.S., Health Physics 5 (1961) 20.
- (9) SPURNY, F., MEDIONI, R., PORTAL, G., Nucl. Instr. and Meth. 138 (1976) 165.
- (10) SPURNY, F., KRALIK, M., MEDIONI, R., PORTAL, G., Nucl. Inst. and Meth. 137 (1976) 593.

ABSORPTION OF X-RAYS WITH ROENTGEN DIAGNOSTIC ENERGIES  
IN THERMOLUMINESCENCE DOSEMETERS

P. Kragh

Institut für Strahlenhygiene des Bundesgesundheitsamtes  
8042 Neuherberg/München, Bundesrepublik Deutschland

## 1. INTRODUCTION

Thermoluminescence dosimeters (TLD) are recently preferred in experiments for the measurement of gonade doses caused by the radiation exposure in Roentgen diagnostics (1,2). They are smaller and less fragile than condenser chambers. Another advantage is the wide range of exposure, i.e. for measurements near the edge of the field, where the expected dose is difficult to estimate. A disadvantage is the high energy dependence of some detector materials. Thus,  $\text{CaF}_2$ -dosimeters have more rarely been applied than the relatively energy-independent but less sensitive  $\text{LiF}$  dosimeters. However, for radiation qualities in the Roentgen diagnostic field with voltages between 40 and 130 kV and filtrations with 1.5 to 3 mm Al this energy dependence is not very effective.

In the past, little attention was paid to the effect of the detector material on the attenuation of the energy flux density of the radiation within the detector and its vicinity. The attenuation of the energy flux density in the detector material influences the response as a function of energy and the response as a function of radiation direction.

## 2. EXPERIMENTAL DETERMINATION OF THE ENERGY DEPENDENCE

The measurements were carried out with the HARKSHAW dosimeter Type No. 2000. The detectors, TLD 100 ( $\text{LiF}$ ) and TLD 200 ( $\text{CaF}_2$ ), are rods ( $1 \times 1 \times 6 \text{ mm}^3$ ) and ribbons ( $1/8 \times 1/8 \times 0.035 \text{ in}^3$ ).

For the determination of the energy dependence, rods were calibrated for several photon energies and radiation directions vertical to the longitudinal axis. Energy spectra with small energy distributions were produced by heavy filtration of the radiation (3). The response as a function of energy is marked by crosslets in Figure 1.

In order to determine the directional dependence, ribbons were calibrated for two different orientations in the radiation. The quotient of the response for the two orientations in dependence of the tube voltage is marked by crosslets in Figure 2.

## 3. CALCULATION OF THE CALIBRATION FACTOR

The calibration factor was calculated with Monte Carlo Methods from the energy absorption coefficient and the total attenuation coefficient of the detector materials (4,5). For the calibration the spectra of Mika and Reiß (6) were used. Figure 3 gives the results of calculations both for parallel X-ray beams (direction distributions 1 and 3) and for isotropic radiation (direction distribution 2) as a function of the tube voltage. Isotropic distributions are difficult to realize in experiments. Because the satisfying agreement of measurements and calculations in Figure 1 and 2, corresponding measurements were omitted.

## 4. RESULTS

For radiation qualities used in Roentgen diagnostic, the dependence of the dosimeter response from tube voltages above 50 kV (Figure 3) is small. Much more critical is the orientation of the detector in the radiation field (Figure 2 and 3).

FIG. 1: DOSEMETER RESPONSE RELATING TO THE DOSEMETER RESPONSE AT THE ENERGY OF  $CO_{60}$  MEASURED IN AIR

Thickness of the dosemeter: 1 mm

Calculations: —

Measurements: +

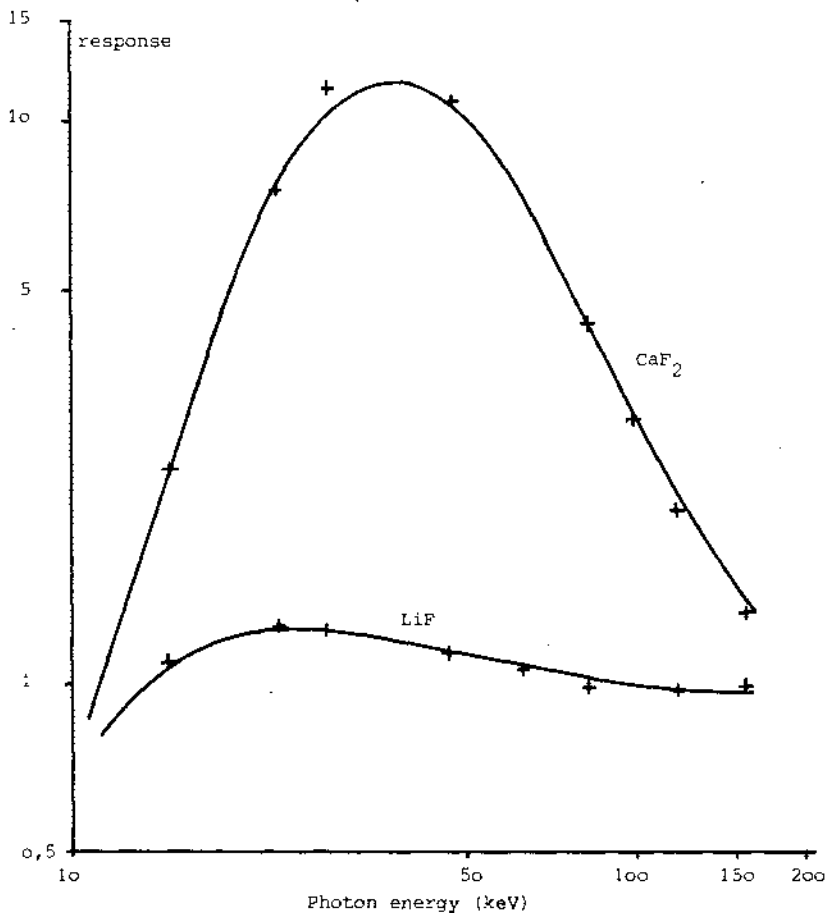

Generally, the detectors are calibrated in parallel X-ray beams and not under conditions practically used. Furthermore, when doses are measured at a patient during X-ray examination, in most cases neither the spectrum nor the direction distribution of the radiation at the measuring spot are exactly known. It might also be difficult to fix the detector every time at the measuring spot with the same orientation. For measurements under these conditions it can be expected that the response is similar to that for the isotropic radiation field. The mean relative errors due to the direction dependence were calculated for LiF detectors to be approx. 3% and for CaF<sub>2</sub> detectors to be approx. 10%. The errors due to the dependence from the radiation quality are of the same magnitude.

FIG. 2: RELATION OF THE DOSEMETER RESPONSES AT RIBBONS (3,2mmx3,2mm x0,9mm) FOR TWO DIFFERENT ORIENTATIONS IN THE RADIATION FIELD AS A FUNCTION OF THE TUBE VOLTAGE

Filtration: 1,5 mm Al  
 Orientation 1: → □  
 Orientation 2: → ▽  
 Calculations: —  
 Measurements: +

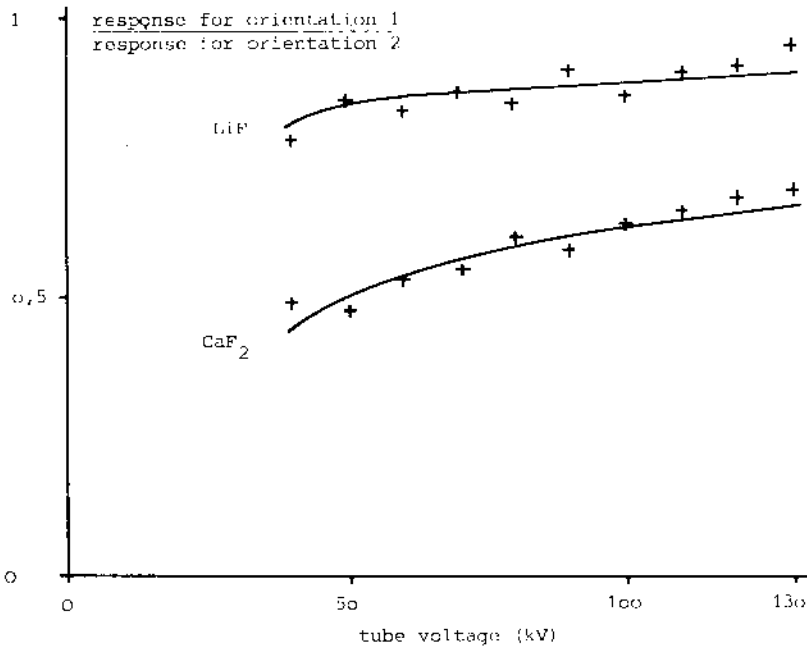

References:

- (1) KOHN, I.A., HEUYSKENS, Chr.J.: Gonadendosen bei Männern als Folge der Röntgendiagnostik, Bericht des Internationalen Reaktorinstituts Delft, Nr. 190-75-05(1975)
- (2) HASMAN, A., GROOTHEDDE, R.T.: CaSO<sub>4</sub> (Dy) Thermoluminescent dosimeters for the determination of gonadal doses, Acta Radiologica Therapy Physics Biology 14(1975)369 ff
- (3) DREXLER, G., GOSSRAU, M.: Spektren gefilterter Röntgenstrahlung für Kalibrierzwecke, GSF-Bericht S 45(1968)
- (4) FRANK, M., STOLZ, W.: Festkörperdosimetrie ionisierender Strahlung, Verlag Chemie GmbH, Weinheim/Bergstr. (1969)
- (5) McMASTER, W.H.: Compilation of X-ray cross sections, UCRL-50174 Sec. II, Rev.1, Lawrence Radiation Laboratory, University of California, Livermore (1969)
- (6) MIKA, N., REISS, K.H.: Tabellen zur Röntgendiagnostik, Siemens AG, Erlangen Teil I(1969), Teil II(1973)

FIG. 3: DOSEMETER RESPONSE FOR RIBBONS (3,2mmx3,2mmx0,9mm) AS A FUNCTION OF THE TUBE VOLTAGE AT FILTRATION WITH 3 mm AL RELATING TO THE RESPONSE FOR THE RADIATION WITH 120 kV TUBE VOLTAGE AT DIRECTION DISTRIBUTION 1

Direction distribution 1:  $\rightarrow \blacksquare$   
 Direction distribution 2:  $\rightarrow \blacksquare$   
 Direction distribution 3:  $\rightarrow \square$

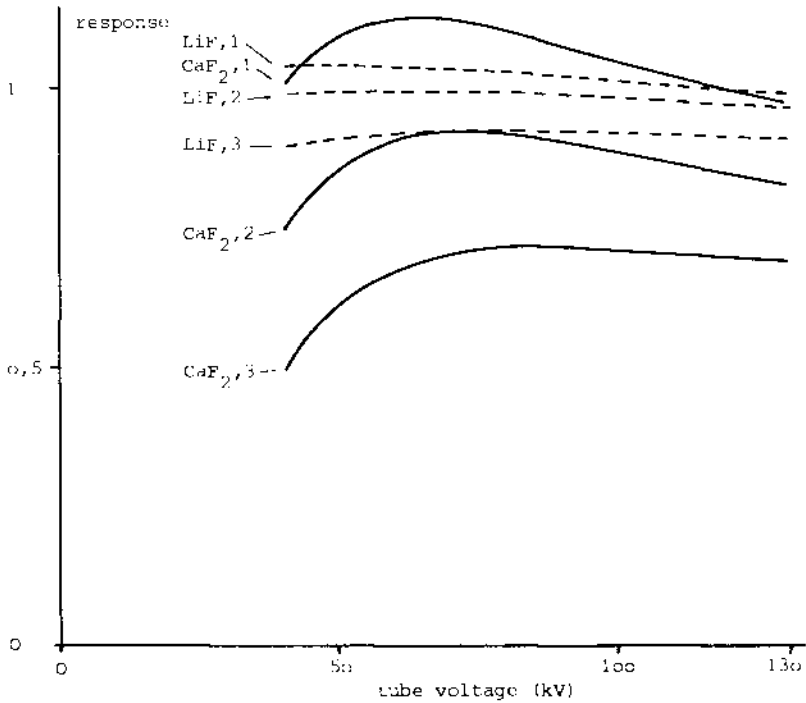

TLD and RPL Dosimeter Performance Criteria for Environmental Monitoring based on Type Tests and Long-Term Experience

E. Piesch, B. Burgkhardt

Health Physics Division, Karlsruhe Nuclear Research Center

Fed. Rep. Germany

1. INTRODUCTION

Since 1966, solid state dosimeters have been applied for the monitoring of the environment at more than 250 field sites at the Karlsruhe Nuclear Research Center [1]. After exposure periods up to 6 years, the reproducibility of measurement (2σ value) for the background level of 60 mR/a was found to be in the order of + 4 mR/a with phosphate glasses, + 4 mR/a for a 4 weeks period with CaF<sub>2</sub>:Dy and ± 6 mR/a for a dose rate measurement [2].

Although dosimeter systems with higher accuracy may be applied now, the properties of different TLD readers even of one type is not comparable because of variations either in the PM dark current or in the reproducibility, which may vary by more than a factor 100 and a factor 4, respectively. Accuracy in the low dose range is mainly affected by the zero roading of unexposed detectors, the uniformity and constancy of the detector response after repeated measurements, the post-exposure treatment, the annealing method applied as well as by the period of exposure and the fading.

Therefore, a well founded type test programme has been performed to collect data about the actual state of the art in TL and RPL dosimetry focussing on the problem of selection and application of a suitable dosimeter system. The quality of a system is mainly based on the properties of the individual reader to such an extent that results of other laboratories with the same type of reader or the application of evaluation techniques of the current literature cannot replace an extended performance test with each reader or dosimeter system.

2. REPRODUCIBILITY

For an application in environmental monitoring, measurements are made during exposure periods of several days up to a year which requires accuracy over the mR dose range. The reproducibility found for measurements using only a single dosimeter are presented in Fig. 1 as a function of exposure for four of the seven different dosimeter systems investigated (s. Table 1), based on the maximal deviation within a batch of 10 dosimeters after individual detector calibration. The lower detection limit D<sub>L,DL</sub> defined here as the equivalent exposure for the 3σ value of the dark current deviation was found to be 0.2, 2 and 8 mR for LiF:Mg,Ti detectors and 10 mR for phosphate glasses. For exposures higher than 100 × D<sub>L,DL</sub> a sufficient

DOSIMETER SYSTEM	TLD SYSTEM						
	1	2	3	4	5	6	7
READER	PITMAN HARSHAW JSHIBA						
TYPE	1395	1397	2200	1392	1393	1394	1395
MATERIAL	CaF <sub>2</sub> :Dy	CaF <sub>2</sub> :Dy	CaF <sub>2</sub> :Dy	CaF <sub>2</sub> :Dy	CaF <sub>2</sub> :Dy	CaF <sub>2</sub> :Dy	CaF <sub>2</sub> :Dy
SIZE (mm)	3 x 3 x 0.9	3 x 3 x 0.9	3 x 3 x 0.9	3 x 3 x 0.9	3 x 3 x 0.9	3 x 3 x 0.9	3 x 3 x 0.9
EXPOSURE PERIOD	24h	24h	24h	24h	24h	24h	24h
REGENERATION METHOD	YES	YES	YES	NC	NO	YES	YES
DARK CURRENT							
σ	16.9	5.6	4.6	7.8	7.5	-	-
MAX. mR	40.13	7.1	4.1	4.8	10.65	-	-
ZERO-DOSE READING							
σ	19.7	48	55	50	55	7.8	1.8
MAX. mR	1.9	3.3	2.7	6.1	12.4	48.93	6.1
READER STABILITY							
σ	0.02	4.3	0.6	3.0	2.6	0.16	7.3
MAX. %	±0.002	±0.7	±1.5	±3	±4	±0.25	±4.2
LONG-TERM STABILITY							
σ	3.3	3.8	3.2	3.4	4.8	0.33	2.2
MAX. %	46.1	7.3	2.7	46.5	25.9	4.1	44.2
REPRODUCIBILITY							
100% D <sub>L</sub>	15	7.3	4.2	-	-	2.0	3.6
100% D <sub>L,DL</sub>	4.3	1.9	7.3	1.0	7.6	1.2	1.0
MAX. 100% D <sub>L</sub>	25	3.7	7.1	-	-	2.5	4.9
MAX. 100% D <sub>L,DL</sub>	7.5	2.9	3.4	4.2	8.4	1.7	1.7
READER LINEARITY							
MAX. %	±5.5	±2	±5	-	-	±0.4	±4
BATCH UNIFORMITY							
σ	9.4	2.5	7.7	7.4	2.9	0.6	1.9
LOWER DETECTION LIMIT							
D <sub>L</sub> mR	0.7	2	8	4.5	7.5	10	40
D <sub>L,DL</sub> mR	0.04	0.4	1.6	0.26	0.77	10	20
FADING AT 70% D <sub>L,DL</sub>	26%	26%	23%	-	5%	1.5%	7.4%

± max. deviation of pre-dose due to washing treatment

Table 1: Dosimetric Properties of TLD and RPL Systems

short-time reproducibility has been found between 1.5 % and 7 %.

On the other hand, the degree of conformity among 10 repeated measurements or annealing treatments found with a single detector represents the long-term reproducibility under practical conditions (Fig. 2). For a dosimeter system the  $1\sigma$  values vary from 1 % to 5 % showing relatively low deviations within a batch of 10 dosimeters. For the different dosimeter systems (Fig. 3), however, a significant scattering of the  $3\sigma$

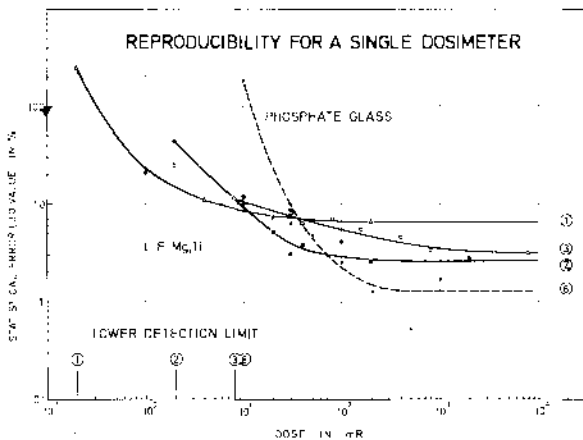

Fig. 1: Reproducibility vs. exposure

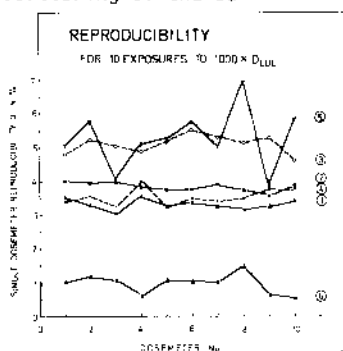

Fig. 2: Long-term reproducibility

values has been found depending on the reader (system No. 1,2,3), on the annealing treatment (system No. 2,4) or on the detector material (system 4,5).

### 3. SENSITIVITY

To investigate the effect of the sensitivity of detector material and reader on the long-term stability in the lower dose range, the  $3\sigma$  deviation of the dark current as well as the zero reading of unexposed dosimeters after repeated measurements and annealing, respectively, are of interest (Fig. 4). Especially for high sensitive TLD readers, for which the zero reading may be extremely higher than the dark current, both values must be subtracted from the dosimeter reading. Annealing

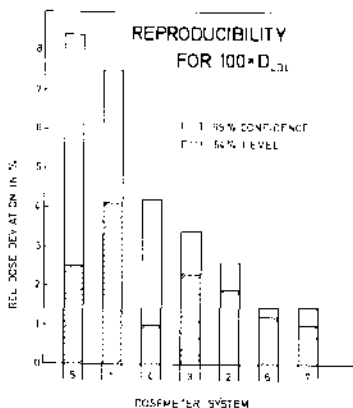

Fig. 3: Short-term reproducibility

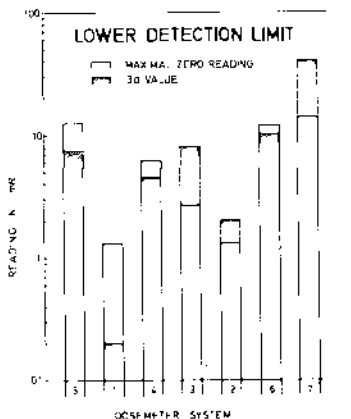

Fig. 4: Lower detection limit

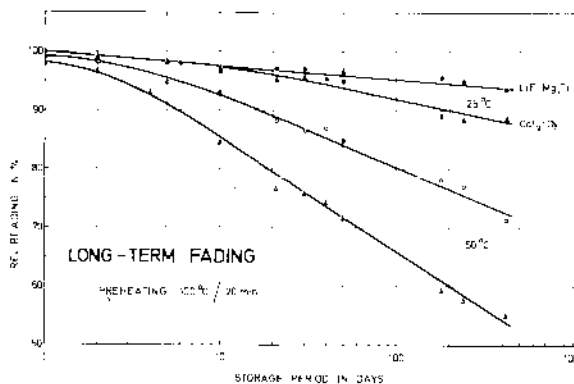

Fig. 5: Fading related to 1 day storage at 25°C

humidity in the environment may influence the stability of the dose reading. The dependence of fading on storage time and temperature is presented in Fig. 5 for LiF:Mg,Ti and CaF<sub>2</sub>:Dy ribbons [3]. Improvements in the temperature and period of post-irradiation treatment before evaluation may reduce the fading, for instance after 50 days at 50°C practically to zero for LiF:Na,Mg (see Fig. 6) or for LiF:Mg,Ti and even for CaF<sub>2</sub>:Dy [4] to values in the order of 5%. On the basis of such preheating treatment, additional calibration exposures for the correction of the field fading may be avoided and errors minimized.

#### 5. DOSIMETRIC PROPERTIES

The properties of the dosimeter systems investigated are presented in Table 1 based on the results of 10 dosimeters or exposures. The maximal statistical error of the measurement with a single dosimeter (reproducibility) is found to be in the order of 2.5% to 25% for 10 x D<sub>LOL</sub> or between 3% and 9% for the measurement of 30 mR depending mainly on the individual reader. Further errors arise from the uncertainty for the individual dosimeter calibration of 1% to 4% (1σ value), the subtraction of the zero dose in the order of 1.2 mR to 20 mR and the non-linearity of the reader (s. Fig. 7).

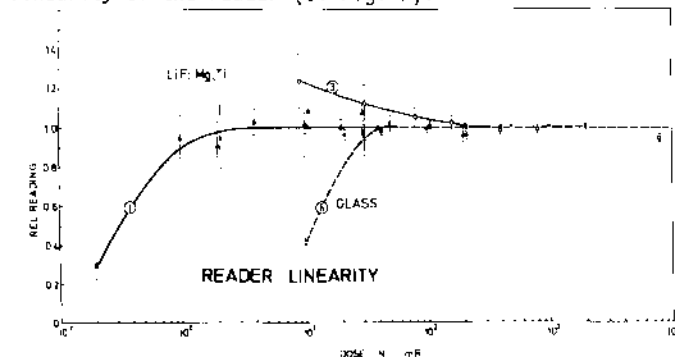

Fig. 7: Reader linearity vs. dose

treatments must be applied for system 4 and 5 to yield zero readings below 3 mR, otherwise apparent doses up to 10 mR will be indicated. In phosphate glass dosimetry, on the other hand, the maximal error due to pre-dose subtraction is in the order of 10 mR mainly arising from the washing treatment.

#### 4. FADING

During long-term field exposures, variations with both temperature and

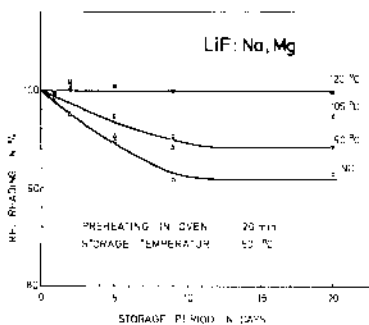

Fig. 6: Reduction of fading of LiF:Na,Mg pellets



In addition, appropriate methods of calibration and interpretation must be applied to reduce systematic errors due to additional non-field exposures or environmental effects. For instance field exposures behind a Pb shielding or laboratory exposures with similar dose rates of 10  $\mu\text{R/h}$  may be used to correct for flight doses or for the individual fading during the field exposure [5].

## 6. CONCLUSION

The paper discusses difficulties concerning the selection of appropriate dosimeter systems for an application in environmental monitoring among others, variations found in the reproducibility and sensitivity even of TLD readers of the same type.

But even with the best system, there is a principal uncertainty of measurement, if an increase in the natural background dose must be estimated. This uncertainty is primarily given by the amount of background dose and the remaining statistical errors of the dosimeter system [6]. For the measurement of low exposures with a single dosimeter an overall uncertainty of at least 10 % should be considered. Variation with both time and space of the natural background dose in the order of 15 % may increase the measuring errors and thus the smallest detectable dose contribution due to the release of radionuclides from nuclear plants. The sensitivity of the dosimeter system does not improve the uncertainty but affects the exposure period which may be at least 1 week for  $\text{CaF}_2:\text{Dy}$ , but more than 3 months or 1 year for  $\text{LiF}:\text{Mg,Ti}$  and phosphate glasses.

## 7. REFERENCES

- [1] Burgkhardt B., Piesch E., Winter M.: Proc. IRPA Congress Washington 1973, p. 394
- [2] König L.A., Piesch E., Winter M.: Proc. Jahrestagung des Fachverbandes für Strahlenschutz, Helgoland, 1974, p. 615
- [3] Burgkhardt B., Piesch E., Herrera R.: Proc. Int. Conf. Lumin. Dosimetry, Sao Paulo, 1977
- [4] Burgkhardt B., Piesch E.: Nuc]. Instr. and Meth., in preparation
- [5] ANSI Publication N545-1975
- [6] Piesch E.: Kerntechnik 19, No 2, 1977

STABILITE DE DIVERS SULFATES DE CALCIUM RTL DESTINES AUX MESURES  
D'ENVIRONNEMENT

S. LORRAIN\* - R. PIAGGIO BONSI\* - G. PORTAL\*

\*Département de Protection, STEP/STID, Commissariat à l'Energie  
Atomique - B.P. N° 6 - 92260 FONTENAY-aux-ROSES - France -

## 1. INTRODUCTION.

Les doses dues aux radiations de l'environnement sont faibles; on entreprend les mesures sur des temps longs, fonction aussi de la sensibilité du détecteur. Il est indispensable que ce dernier intègre alors la réponse exploitable, sans pertes.

Les sulfates de calcium activés au Dysprosium (Dy) ou au Thulium (Tm) ont été choisis à cet effet, parce que ce sont des matériaux RTL très sensibles. Divers auteurs ont cependant signalé leur instabilité qui peut entraîner, en six mois, une perte de 7 % de l'information, d'après T.YAMASHITA et al. (1), voire même 30 %, d'après V.MELDAHL, (2).

Leur emploi comme dosimètre a nécessité la mise au point d'une méthode de détermination des stabilités. Une mesure directe valable exige un grand délai, souvent incompatible avec les conditions d'expérience; on l'effectue par contre, à posteriori dans tous les cas.

L'idée d'accélérer les processus de "fading" par élévation de la température conduit à étudier la décroissance thermique de la RTL. L'expérience montre qu'elle obéit toujours initialement à une loi exponentielle, caractéristique d'une évolution cinétique du 1er ordre; l'identification phénoménologique au modèle de J.T.RANDALL et M.H.P. WILKINS (3) se justifie. La  $\frac{1}{2}$  vie du pic dosimétrique définissant la stabilité du dosimètre RTL, s'obtient indirectement, en passant par le calcul de l'énergie d'activation E et du facteur de fréquence S, selon la méthode des décroissances isothermes, appliquée par certains auteurs à d'autres matériaux RTL (4) (5).

Ce travail concerne 3 sulfates de calcium de différentes origines : 2 sont préparés au laboratoire ( $\text{CaSO}_4$ , Dy et  $\text{CaSO}_4$ , Tm); le 3ème étant du ( $\text{CaSO}_4$ , Dy) commercial.

## 2. RAPPELS THEORIQUES.

Par interaction avec les atomes du cristal, les rayonnements nucléaires libèrent des porteurs de charges ( $e^-$ , trous) qui diffusent dans le sillage des trajectoires à l'intérieur de canaux d'excitation. La particularité du matériau RTL est de fixer à l'état métastable une partie de ces charges mobiles, dans des sites privilégiés ainsi excités à des niveaux d'énergie discrets (pièges). L'apport de chaleur (phonons) comme en TL - ou de lumière (photons) comme en E.E.P.S. - chasse ces porteurs bloqués vers des centres de recombinaison luminogènes, d'ionisation opposée, qui préexistent dans le cristal (activateur) à des niveaux énergétiques intermédiaires, de la bande interdite. Ils sont alors le siège de transition électronique radiative (phosphorescence), à la condition que l'énergie initiale qui leur est communiquée soit supérieure à celle de la bande caractéristique du cristal la plus proche du piège de départ (bande de conduction - BC - ou bande de valence - BV).

Les énergies d'activation thermique ( $E_i$ ) des porteurs retenus dans un même piège sont supposées réparties selon une distribution de BOLTZMANN-MAXWELL, par analogie à la théorie cinétique des gaz. La probabilité p

(s<sup>-1</sup>) qu'a l'e<sup>-</sup> (ou le trou) de quitter son piège de profondeur E(eV) à la température T(°K) est donnée par :

$$P(T) = S \exp.(-E/kT) \quad (I)$$

dans laquelle k est la constante de BOLTZMANN et S, un paramètre caractéristique du piège, appelé facteur de fréquence.

A chacun des pics de la courbe de TL (glow curve) est associé un type de pièges, donc des valeurs particulières de E et de S.

Si on irradie un matériau RTL qu'on maintient ensuite à la température fixe T, un intervalle de temps  $\Delta t$ , le nombre de porteurs de charge restant piégés est donné par :

$$N = N_0 \exp.(-P(T) \cdot \Delta t) \quad (II)$$

N, N<sub>0</sub> étant les nombres d'e<sup>-</sup> (ou de trous) piégés aux temps t et t<sub>0</sub> (origine des temps). La méthode consiste à suivre la décroissance thermique relative de la RTL du pic principal, à plusieurs températures fixes. L'analyse des courbes obtenues montre, qu'à toute température, celles-ci résultent de la superposition de 2 exponentielles élémentaires à paramètres d'amplitude constants, mettant ainsi en évidence la présence de 2 niveaux d'énergie E<sub>1</sub> et E<sub>2</sub>. C'est-à-dire que l'on a :

$$(N/N_0) = (N_1/N_0) \exp(-p_1 \cdot \Delta t) + (N_2/N_0) \exp. (-p_2 \cdot \Delta t) \quad (III)$$

La partie expérimentale est traitée en détails dans (6).

### 3. RESULTATS.

Nous avons utilisé la méthode d'ajustement exponentiel par les moindres carrés, avec pondération des mesures; celle-ci permet une sérieuse compensation de l'erreur statistique. Nos résultats sont rassemblés dans les tableaux ci-joints.

### 4. CONCLUSION.

La méthode des décroissances isothermes de la RTL a permis de montrer que les pics dosimétriques habituels des CaSO<sub>4</sub> activés au Dy ou au Tm résultent du recouvrement de 2 niveaux d'énergie voisins et qu'on peut disposer de matériaux à faible fading adaptés aux mesures de l'environnement.

L'étude, à l'ordinateur, de la propagation théorique et statistique de l'erreur expérimentale, jusqu'à celle de E et de S, est en cours; elle doit nous donner les limites et les possibilités de principe optimales, de la méthode; nous envisageons de l'appliquer ensuite à d'autres matériaux RTL utilisés au laboratoire. La détermination empirique de la reproductibilité des résultats indique que les valeurs annoncées de E et de S sont connues respectivement à 3 et 30 % près. Notre but est d'améliorer cette précision. Il existe aussi une différence entre les stabilités des sulfates, nettement en faveur des sulfates activés au Dy, comparativement à celui dopé au Tm quia la singularité d'inverser l'ordre des niveaux E<sub>1</sub> et E<sub>2</sub> du Dy.

Nos résultats sont relatifs à la première utilisation, du produit neuf. Nous cherchons à voir par ailleurs l'évolution éventuelle de ces caractéristiques, avec les réutilisations répétées successives (irradiation suivie de recuit).

### REFERENCES

- (1) YAMASHITA, T., NADÁ, N., ONISHI, H. and KITAMURA, S., Calcium sulfate activated by thulium or dysprosium for thermoluminescence dosimetry. Health Physics, 1971, 21, 295 - 300.
- (2) MEJDAHL, V., Dosim. techniques in thermoluminescence dating Risø Report n° 261, Danish Atomic Energy Commission, 1972

- (3) RANDALL, J.T. and WILKINS, M.H.P., Phosphorescence and electron traps  
Proc. R.Soc. (London) A, 1945, 184, 366 - 407
- (4) ZIMMERMAN, D. and CAMERON, J.R., Thermal decay of TLD-100. Investigation of TL radiation dosimetry. Progress report US AEC-Contract AT 11-1-1105, 1963
- (5) SPURNÝ, Z. and NOVOTNÝ, J., Fading in thermoluminescent dosimetry, Proc.Third Int. Conf.Lumin.Dos., RISO-rep 249-Danish AEC, vol.1,p.132 Roskilde, 1971
- (6) PIAGGIO-BONSI, R., LOHRAIN, S., PORTAL, G., Etude de la stabilité des pièges dans le  $\text{CaSO}_4$  : Dy RTL pour les mesures d'environnement-VIIIème Congrès International de la S.F.R.P. 23-26 mars 1976-SACLAY-FRANCE-

T (°C)		$N_1 / N_0$	$N_2 / N_0$	$P_1 (h^{-1})$	$P_2 (h^{-1})$
170	a)	0,155	0,850	62	3,1
	b)	0,161	0,834	50,8	3,15
	c)	"	"	"	"
150	a)	0,163	0,850	15,1	0,45
	b)	0,158	0,832	15,4	0,53
	c)	0,107	0,898	12,2	0,35
140	a)	0,162	0,823	6,4	0,19
	b)	"	"	"	"
	c)	0,102	0,900	5,5	0,15
130	a)	0,155	0,850	2,5	0,075
	b)	0,148	0,845	2,0	0,081
	c)	0,106	0,892	1,9	0,069
120	a)	0,152	0,845	0,77	0,021
	b)	0,150	0,848	0,80	0,03
	c)	0,104	0,904	0,50	0,02
110	a)	0,151	0,848	0,20	0,0052
	b)	0,165	0,830	0,19	0,0065
	c)	0,109	0,906	0,22	0,0068

Nous donnons, dans le tableau ci-dessus, les résultats obtenus pour :

a) le  $\text{CaSO}_4$  : Dy FAR - b) le  $\text{CaSO}_4$  : Dy Commercial - c) le  $\text{CaSO}_4$  : Tm FAR -

Matériau	Energie d'activation (eV)		Facteur de fréquence ( $\times 10^{14} s^{-1}$ )		Demi-vie à 20°C (ans)		$T_M$ du pic (°C) calculée	
	$E_1$	$E_2$	$S_1$	$S_2$	Niv.1	Niv.2	Niv.1	Niv.2
( $\text{CaSO}_4$ , Dy) <u>FAR</u>	1,39	1,53	1,5	2,3	123	20 105	220	260
<u>Commercial</u>	1,36	1,47	0,5	0,5	110	8 590	220	260
<u><math>\text{CaSO}_4</math>, Tm</u>	1,46	1,38	8,0	0,03	360	4 050	215	280

Finalement, les caractéristiques théoriques trouvées pour les niveaux dosimétriques doubles ( $E_1$  et  $E_2$ ) des  $\text{CaSO}_4$ :Dy (ou Tm) sont groupées ci-dessus.

**CaSO<sub>4</sub>: Dy**

**FIG 3 COURBES DE DECROISSANCE THERMIQUE**

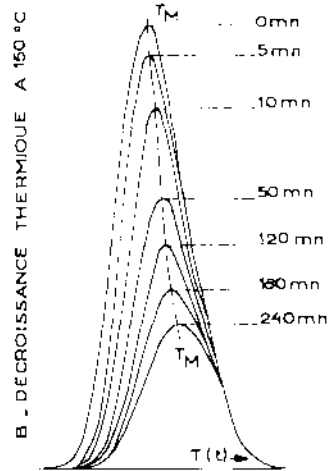
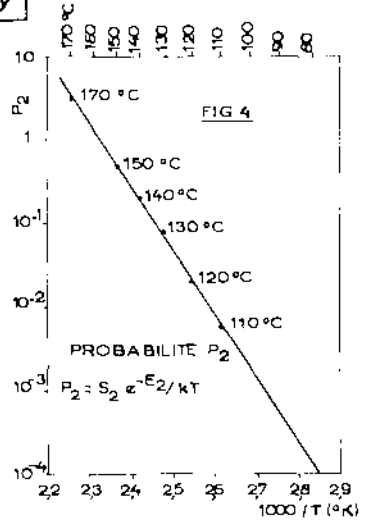
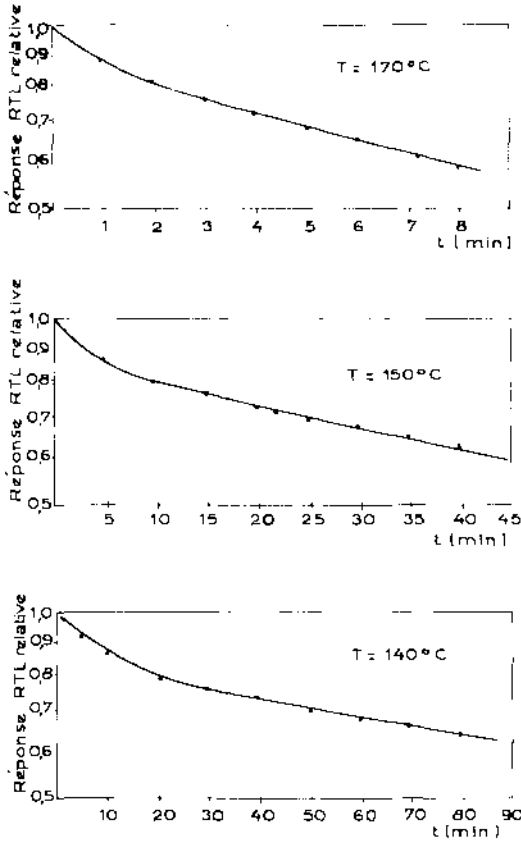

**FIG1 SPECTRE RTL**

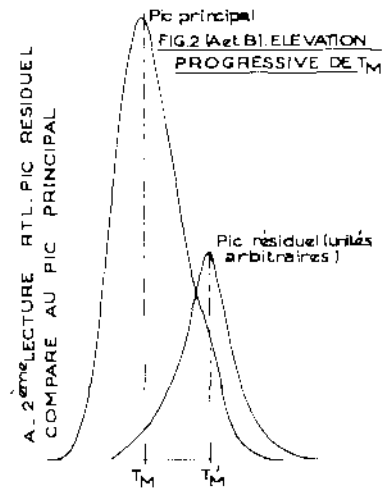
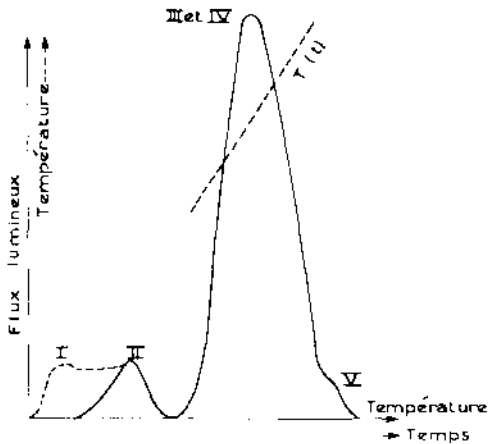

MEASUREMENTS OF DOSES IN THE 1mrad RANGE BY MEANS OF LiF, CaF<sub>2</sub>  
AND CaSO<sub>4</sub> DOSIMETERS AND DETERMINATION OF THE ENERGY RESPONSE<sup>2</sup>  
OF LiF AND CaF<sub>2</sub>

N.Vana, H.Aiginger and W.Erath

Atomic Institute of the Austrian Universities,  
Schüttelstrasse 115, 1020-Vienna, Austria

Dosimetric measurements in the millirad and submillirad region are of growing interest for the evaluation of environmental doses as well as for the evaluation of the doses obtained during an individual procedure of X-ray diagnostics(1,2). TL-dosimeters offers a special advantage for both purposes as they are of small size and therefore do not irritate the persons whose radiation hazard has to be monitored. Additionally the small size of these dosimeters offer a high position sensitivity which is advantageous especially for the above mentioned application in personnel dosimetry.

Application of LiF(TLD-100) and CaF<sub>2</sub>:Dy(TLD-200) dosimeters in the millirad and submillirad region have been tested. Extruded chips of TLD-100 and single crystals of TLD-200(6,35 x 6,35 x 0,9 mm<sup>3</sup>) were used. A modified EG & G-reader with increased sensitivity was utilized for the evaluation of the dosimeters. In preparing the dosimeters for measurements in the above mentioned dose range a special annealing cycle was necessary. At first the TLD-200 crystals were annealed for half an hour at 450° in a special oven, after this time the temperature was decreased with a temperature gradient of 30°/h. At the temperature of 430° the TLD-100 chips were inserted in the oven. After approximately 12 hours a temperature of 80° was obtained. Both types of dosimeters remain for 5 hours at this temperature. The reproducibility of the annealing cycle is of outmost importance for the reproducibility of the sensitivity in the low dose region.

The relative TL-response as a function of the radiation dose was measured with co-60 gamma radiation. During the measurements electron equilibrium in air or in polyethylene has been established. The detection limit (net signal = 3 X standard deviation of the non radiation induced TL-signal) is 1 mR for TLD-100 and 50 µR for TLD-200 (Fig.1).

The energy response of the two types of dosimeters used was determined in the energy range from 10 keV to 1,25 MeV. For the region between 10 keV and 50 keV monochromatic x-rays were obtained by means of a Bragg-monochromator. The Bragg-monochromator - a commercially available x-ray spectrometer - reflects selectively monochromatic x-rays from a continuous bremspectrum of a tungsten x-ray tube. The energy resolution obtained was 2 - 4%. The photon flux at the dosimeter was measured with a Ge(Li)-semiconductor detector. From this

photon flux the actual exposure of the dosimeters has been calculated. Above 50 keV the filtered bremsstrahlung from a thick gold target of a Van de Graaff accelerator was used for the determination of the energy response. The spectrum of the filtered bremsstrahlung was measured by means of a Ge(Li)-semiconductor spectrometer system. A Cs-137 source (662 keV) and a Co-60 source (1,25 keV) was used to obtain the respective points of the response curve.

The response function derived was normalized to the response of Co-60 for the free air measurements. The response function of the dosimeters covered with polyethylene to establish electron equilibrium is normalized to the dosimeter response for Co-60 (4m source detection distance, 6 mm thick polyethylene). Fig.2 shows the energy dependence of the response of TLD-100, TLD-200 and of the relation: response TLD-200/response of TLD-100 from the free air measurements. At approximately 35 keV the maximum sensitivity occurs:  $1,3/\pm 1\%$  for TLD-100,  $12,7 \pm 7\%$  for TLD-200 and  $9,5 \pm 6\%$  for the response relation TLD-200/TLD-100.

Fig.3 shows the energy dependence of the response of TLD-100 between 10 keV and 250 keV for electron equilibrium in air and in tissue equivalent polyethylene.

The calibrated TLD-200 dosimeters were used for environmental dosimetry. Fig.4 presents the readings of the dosimeters exposed for 1 to 6 hours to the natural background radiation. The slope of the regression line is the environmental dose rate of  $11,0 \pm 1,5$   $\mu$ R/h at the respective laboratory site.

The physical and dosimetric properties of homemade  $\text{CaSO}_4:\text{Dy}$  have been investigated especially the dependence of the light-output, the sensitivity and the detection limit on the Dy-concentration (Table 1). The influence of the fading can be reduced by preannealing for 1/2 hour at 140°C. Therefore only the main glow peak at 210°C remain for the dosimetric evaluation.

Dosimeter	Sensitivity	Detection limit (mrad)	Fading % in the 1 month
TLD-100	1 .	1	3
TLD-200	50,8	0,05	12
$\text{CaSO}_4:\text{Dy}(0,1\%)$	30,6	0,1	4
$\text{CaSO}_4:\text{Dy}(0,2\%)$	33,7	0,2	20
$\text{CaSO}_4:\text{Dy}(0,5\%)$	41,1	0,3	17

TABLE 1 Dosimetric properties of the TLD-materials used

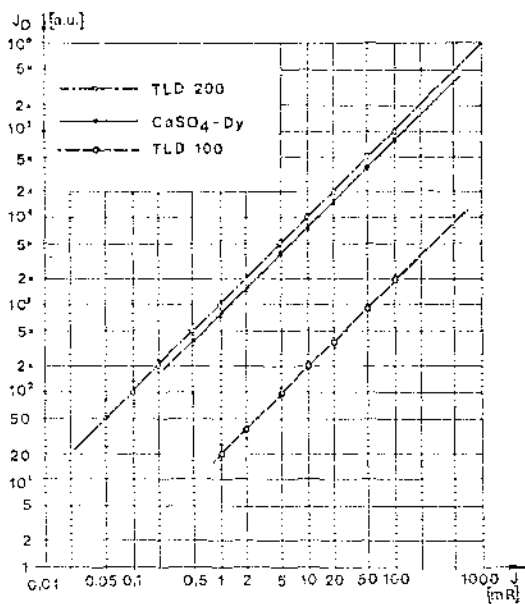

FIG 1 Relative TL-response

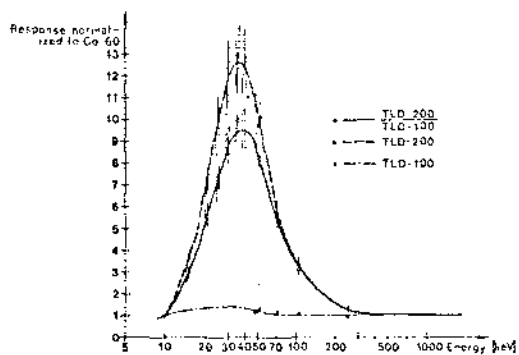

FIG 2 Photon energy dependence of response free air



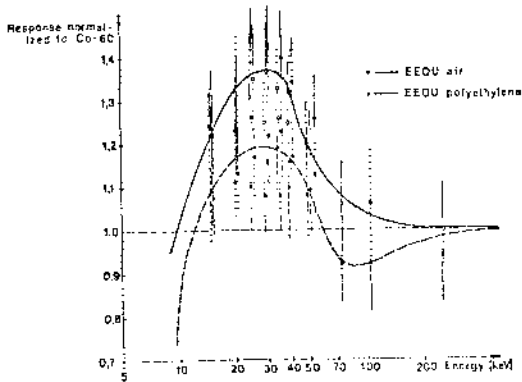

FIG 3 Photon energy dependence of TLD-100

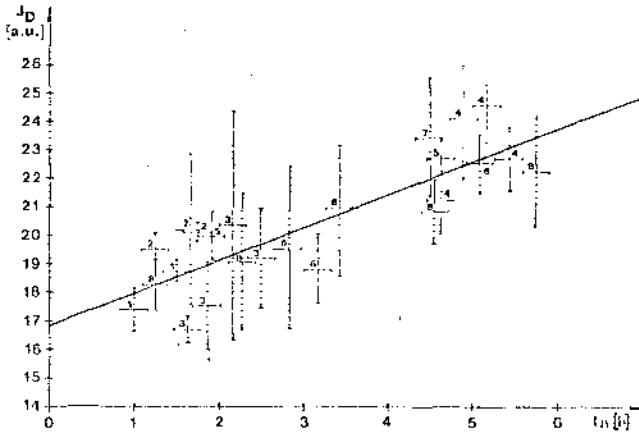

FIG 4 Enviromental dose determination

#### REFERENCES

- (1) VANA N., KREPLER P., HAVRANECK Ch., Measurement of the gonad dose of infants during x-ray examination of the hip. 4th International Congress of the IRPA, paris 1977, Comm.370
- (2) WANECK R., VANA N., LECHNER G., Strahlenbelastung des medizinischen Personals bei angiographischen Untersuchungen. AIAU Report 76110, 1976

A TWO TEMPERATURE READOUT OF THERMOLUMINESCENT LiF,  
ITS PROPERTIES AND USES FOR PERSONNEL DOSIMETRY

M. Marshall, J.A. Douglas, T. Budd and W.C. Churchill

Environmental and Medical Sciences Division,  
Atomic Energy Research Establishment,  
Harwell, Didcot, Oxfordshire,  
OX11 0RA, United Kingdom

1. INTRODUCTION

Lithium fluoride is used extensively as a thermoluminescent dosimeter for ionising radiations. As the material is heated a glow curve is produced consisting of a series of peaks. The peaks normally used for dosimetry (peaks 3, 4 and 5) are read out by heating to a temperature about 240°C. However it is well known that there are higher temperature peaks which can be read out at temperatures about 300°C. For radiations with high LET (Linear Energy Transfer) these peaks are more prominent than for gamma radiation (1, 2). In particular, the response of  ${}^6\text{LiF}$  to thermal neutrons depends on the  ${}^6\text{Li} (n, \alpha) {}^3\text{H}$  reaction where the high LET products substantially enhance the high temperature peaks.

When using  ${}^6\text{LiF}$  to detect thermal neutrons the effect of gamma-rays is normally subtracted using a similar detector of  ${}^7\text{LiF}$  which is insensitive to thermal neutrons. However this use of two detectors, physically similar, can lead to confusion, particularly in routine use. Busuoli et al (3) have read out the low and high temperature peaks in  ${}^6\text{LiF}$  separately and hence obtained thermal neutron and photon doses from the one detector. Another application of the high temperature peaks has been for the re-estimation of gamma-ray dose in  ${}^7\text{LiF}$  (4).

This work is concerned with the response of the low and high temperature peaks to gamma-rays, X-rays and thermal neutrons at low doses. The methods of readout and analysis will be described. Its use in routine albedo dosimetry and other applications of this phenomenon in personnel dosimetry will be discussed.

2. METHOD

Extruded LiF chips of TLD-600 and TLD-700 (The Harshaw Chemical Co) 3.2 x 3.2 x 0.9 mm are used throughout this work. They are annealed at 400°C for 1 hour, cooled at a few degrees Celsius per minute and followed by 16 hours at 80°C.

The reader is a Toledo (D.A. Pitman Ltd) which has been modified so that a TLD can be read out at two temperatures in one cycle. The readout cycle (in a nitrogen atmosphere) consists of a preheat (135°C, 16s), a low temperature read (240°C, 16s) and a high temperature read (300°C, 16s) followed by cooling in the reader to about 100°C (20s). In each part of the cycle the temperature rises rapidly to a plateau at the indicated value. The high temperature read is obtained using the Toledo anneal facility with an external circuit to count the pulses from the internal analogue-to-digital converter.

The two readout temperatures and times are those used in this work, but they may be changed slightly to optimise the separation of the high and low

temperature peaks.

### 3. RESPONSE

The ratio of the two readouts has been determined experimentally for gamma-rays, X-rays and thermal neutrons in TLD-600 (Table 1). Similar results are obtained for TLD-700 (apart, of course, from thermal neutrons).

Radiation	$\frac{300^{\circ}\text{C readout}}{240^{\circ}\text{C readout}}$
Radium $\gamma$ -rays	0.056 $\pm$ 0.001
X-rays: 148 keV (170) *	0.087 $\pm$ 0.006
109 keV (125)	0.097 $\pm$ 0.006
87 keV (100)	0.108 $\pm$ 0.007
61 keV (70)	0.104 $\pm$ 0.006
48 keV (55)	0.112 $\pm$ 0.007
30 keV (35)	0.099 $\pm$ 0.006
Thermal neutrons	0.544 $\pm$ 0.020

\* X-rays: Mean energy keV (Peak energy keV)

TABLE 1 Comparison of Responses at 240°C and 300°C in TLD-600

These ratios depend on the annealing conditions and in particular on the rate of cooling from 400°C. Higher rates of cooling (up to  $\sim 100^{\circ}\text{C}$  per minute) increase the sensitivity of the normal dosimetry peaks (5) but have a much smaller effect on the high temperature peaks. However if the ratios are expressed in terms of the ratio for gamma-rays then this ratio-of-ratios has been found to be constant.

The relative increase of the 300°C readout for X-rays compared with gamma-rays is surprising and is not obvious in the work of Busuoli et al (3).

### 4. DOSE MEASUREMENT IN MIXED FIELDS

For a mixture of two known components (e.g. neutrons and gamma-rays using  $^6\text{LiF}$ ) we have two simultaneous equations with two unknowns. The solution for the neutron dose,  $N$ , can be written as

$$N = \frac{H - R_p L}{C_{NH} (1 - 1/S)} \quad \text{mrem}$$

where  $H$  and  $L$  are the 300 and 240°C readouts respectively,  $R_p$  and  $R_N$  are the ratios, respectively, of photon and neutron sensitivities (300/240°C),  $S = R_N/R_p$  and  $C_{NH}$  is the sensitivity of the 300°C readout to thermal neutrons in counts per mrem.

The uncertainty of the value of  $N$  can be calculated by partial differentiation of the above expression, with respect to the various parameters, and combining the standard deviations in quadrature

$$\text{i.e.} \quad \sigma_N^2 = \left(\frac{\partial N}{\partial H}\right)^2 \sigma_H^2 + \left(\frac{\partial N}{\partial R_p}\right)^2 \sigma_{R_p}^2 + \dots$$

When the photon energy is unknown the effect on  $R_p$  of the photon energy will increase the uncertainty.

## 5. ONE AND TWO TLD READOUT IN ALBEDO DOSIMETRY

Experimental measurements have been made using albedo neutron dosimeters of the Harvey type (6) on phantoms around facilities handling plutonium. The apparent neutron doses and their uncertainties are given in Table 2 for the one and two chip systems.

Phantom No.	$\gamma$ Dose (mrad)	Neutron Dose (App. $\gamma$ mrad 240°C)	
		1 Chip	2 Chip
1	70	242 $\pm$ 57	240 $\pm$ 13
2	360	515 $\pm$ 109	571 $\pm$ 32
3	1590	108 $\pm$ 70	0 $\pm$ 20
4	210	66 $\pm$ 30	91 $\pm$ 11
5	1820	12673 $\pm$ 2275	13111 $\pm$ 550
6	60	174 $\pm$ 44	197 $\pm$ 10
7	80	304 $\pm$ 67	356 $\pm$ 16
8	140	144 $\pm$ 41	186 $\pm$ 11
9	120	481 $\pm$ 98	476 $\pm$ 21

TABLE 2 Comparison of Dose Calculations by the 1 and 2 chip systems

Although generally not as precise as the two chip system the one chip method is adequate for personnel dosimetry. To correct the apparent neutron dose to the true neutron dose for an albedo dosimeter requires a knowledge of the local spectrum and appropriate calibration factors.

More recent work than the above has shown that with bare chips thermal neutron fluences of  $2 \times 10^6 \text{ cm}^{-2}$  can be measured to a precision of 10% (1 standard deviation) in a gamma-ray field of 1 rad. For an albedo dosimeter this is equivalent to about 1 rem of 1 MeV neutrons. Doses of 100 mrem can be measured with a precision of about 30%.

## 6. DISCUSSION

The variation of the 300/240°C readout ratio with photon energy is interesting and will be investigated further for two reasons. Firstly it will help in the understanding of the mechanisms of thermoluminescence in LiF and secondly it shows promise as a method of estimating radiation quality using one TLD of  $^7\text{LiF}$ . The latter can be used to correct the low temperature readout for the energy response of LiF and to indicate the radiation quality of an exposure where this is not known, e.g. in personnel dosimetry using TLD badges for beta-gamma dose estimation.

The precision of the two temperature readout can probably be improved by optimising the times and temperatures of readout and by studying the variation in the 300/240°C readout ratios with various annealing conditions.

## 7. CONCLUSIONS

A two temperature readout of  $^6\text{LiF}$  can be used with sufficient precision for albedo dosimetry in personnel neutron monitoring. Similarly it can be used

for measuring thermal neutron flux in a mixed neutron-gamma-ray field ( $2 \times 10^6 \text{ n cm}^{-2}$  with a relative standard deviation of 10% in the presence of 1 rad of gamma-rays). Experiments to improve the precision are in progress.

The ratio of the high to low temperature peaks in thermoluminescent LiF is dependent on photon energy and will be investigated further.

#### REFERENCES

- (1) AYYANGAR, K., REDDY, A.R., BROWNELL, G.L., "Some studies on thermoluminescence from lithium fluoride and other materials exposed to neutrons and other radiations", p525, Proceedings of the Second International Conference on Luminescence Dosimetry. USAEC-ORNL Conf-680920 (1968).
- (2) MASON, E.W., "The effect of thermal neutron irradiation on the thermoluminescent response of CON-RAD Type-7 Lithium Fluoride", Phys. Med. Biol. 15 1 (1970) 79.
- (3) BUSUOLI, G., et al, "Mixed radiation dosimetry with LiF (TLD-100)", Phys. Med. Biol. 15 4 (1970) 673.
- (4) LINSLEY, G.S., MASON, E.W., "Re-estimation of dose in LiF", p157, Proceedings of the Third International Conference on Luminescence Dosimetry, Riso Rept. No. 249 (1971).
- (5) BRADBURY, M.H., NWOSU, B.C.E., LILLEY, E., "The effect of cooling rate on performance of thermoluminescent dosimeter crystals (TLD-100) and LiF crystals", J. Phys. D: Appl. Phys. 9 (1976) 1009.
- (6) HARVEY, J.R., HUDD, W.H.R., TOWNSEND, S., "Personnel dosimeter for measuring the dose from thermal and intermediate energy neutrons and from gamma and beta radiation", p199, Neutron Monitoring for Radiation Protection Purposes, STI/PUB/318, IAEA, Vienna (1973).

THERMOLUMINESCENT BETA DOSIMETRY FOR ROUTINE  
PERSONNEL MONITORING

L. Benkő, Gy. Uchrin, T. Biró  
Institute of Isotopes of the Hungarian Academy of Sciences

## 1. INTRODUCTION

Thermoluminescent dosimetry is gradually receiving acceptance for extremity dosimetry because of its advantageous properties compared with classical methods (1). The production and application of radioisotopes and the handling of nuclear fuel materials require the measuring of doses also in very inhomogeneous beta fields of a wide energy range. Thin LiF or LiF in teflon with a thickness of about 10 mg/cm<sup>2</sup> together with a versatile reader have been mainly used for such purposes (2). Some of the readers, e.g. Victoreen Model 2800 used for our routine personnel gamma dosimetry, are suitable only for chip, rod and bulb dosimeters. Our work was aimed at developing a dosimeter, adaptable to the Victoreen Model 2800 Reader, fulfilling the basic requirements for routine beta dosimetry.

## 2. EXPERIMENTAL RESULTS

The read-out of the dosimeters was carried out by the LiF-Anneal program of the reader that includes a preheat to 120 °C, integration between 120 and 250 °C and a heat treatment at 340 °C.

<sup>147</sup>Pm, <sup>204</sup>Tl and <sup>90</sup>Sr-<sup>90</sup>Y sources (Amersham type PHC.26, TEC.23 and SIC.106) were used for beta calibration. The beta dose rates were determined by an extrapolation chamber with an error of ±5%. The dosimeters were irradiated in a perspex cylinder with an I.D. of 8 cm, at a distance of 10 cm.

The sensitivity of the dosimeters to X- and gamma-rays was measured using standard X-ray spectra and a standardised <sup>60</sup>Co source, in the National Bureau of Metrology, Budapest.

### 2.1. Beta sensitivity of hot pressed dosimeters

The TL response of several types of LiF and CaF<sub>2</sub>:Mn hot pressed dosimeters have been investigated. The results are presented in Table 1 and Fig.1.

### 2.2. Some properties of a thin CaSO<sub>4</sub>:Dy detector

The results obtained with a CaSO<sub>4</sub>:Dy detector developed by us are shown in Table 1 and Fig. 1. The CaSO<sub>4</sub>:Dy crystals prepared as in Ref. (3) were ground into a powder with grain size of about 30 μm and incorporated into a heat-resistant resin. A layer as thin as about 10 mg/cm<sup>2</sup> of this mixture was fixed on to an Al disc, Ø6x0.5 mm in size, which served as a holder. The detectors were ready to use after a 5 min heat treatment at 300 °C.

The accuracy of the measurements at 100 mrd is better than +20%, taking into account, beside the usual errors, a one

month fading effect and the dose and heat history of twenty times one rd irradiations, too.

The minimal detectable dose is 5 mrd; for practical purposes the detector may be regarded as energy independent.

Material		TL response	
		per mR in $^{60}\text{Co}$ field	per mrd in Sr-Y field
LiF	b	1.50	1.56
	c	1.92	2.00
	d	1.00	0.90
	e	0.52	0.48
CaF <sub>2</sub> :Mn	e	1.48	1.24
	f	0.66	0.58
CaSO <sub>4</sub> :Dy on Al disc	a	0.56	0.93

TABLE 1. TL response of several dosimeters (symbols a-g refer to Fig. 1)

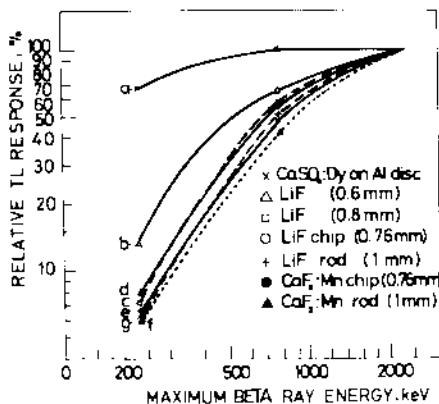

FIG. 1. Sensitivity to beta radiation

### 2.3. Application for mixed beta-gamma fields

In order to extend the use of our CaSO<sub>4</sub>:Dy detector for the monitoring of mixed beta-gamma fields, a special combination of dosimeters and filters was developed (Fig.2). The three-element dosimeter is placed in a small perspex casing and can be worn using an adhesive tape or can be fixed to a perspex ring.

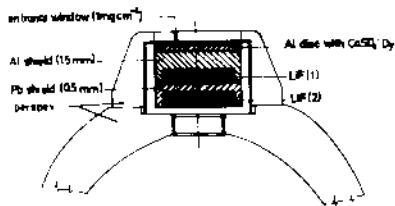
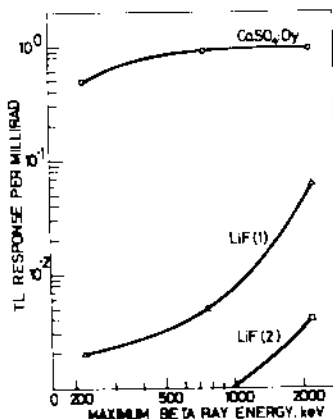

FIG. 2. The three-element dosimeter

FIG. 3. Beta sensitivity of the three-element dosimeter



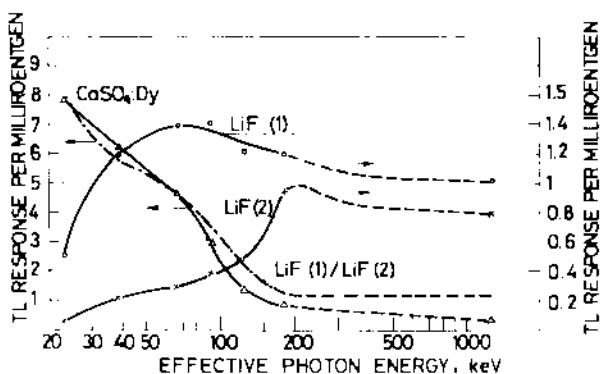

FIG. 4. Gamma sensitivity of the three-element dosemeter

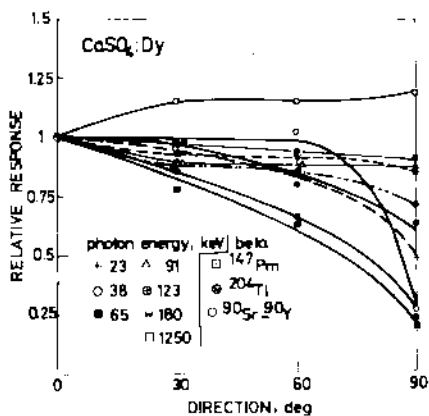

FIG. 5. Directional response of the CaSO<sub>4</sub>:Dy element

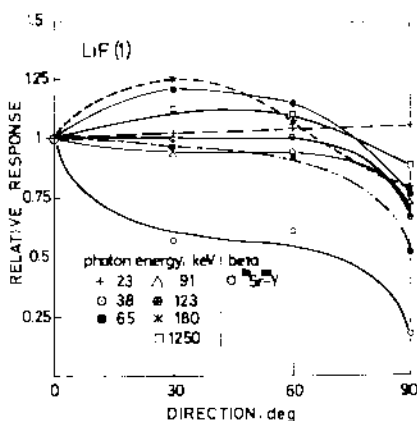

FIG. 6. Directional response of the LiF (1) element

The LiF dosemeters (Victoreen Model 2600-53) and the filters were chosen in such a way that the contribution of low energy photons and hard gamma rays to the TL response of CaSO<sub>4</sub>:Dy detector could be evaluated. The beta and gamma sensitivity of the three-element set is given in Fig. 3 and Fig. 4.

The directional response of each dosemeter in the three-element set was investigated and the results obtained for CaSO<sub>4</sub>:Dy and LiF(1) are presented in Fig. 5 and Fig. 6.



### 3. DISCUSSION

The development of extremity dosimeters is still in progress because of the difficulties of the dose measurement of low energy radiation. The importance of the dose distribution from the viewpoint of health physics requires in many cases not only an energy independent dosimetry but also the knowledge of the radiation quality. This could be the case in a mixed beta-gamma field. A combination of TL dosimeters with appropriate filters can meet such requirements (4).

The three-element dosimeter set developed by us is suitable for dose measurement in pure beta fields with an accuracy of  $\pm 10\%$  if  $E_{\max}$  is higher than 500 keV; the accuracy is  $\pm 20\%$  for  $E_{\max}$  values not exceeding 200 keV.

The LiF dosimeters, used in the set, practically do not respond even to high energy beta radiation; their response to gamma radiation differ significantly in the low energy range. The photon energy below 100 keV can easily be estimated on the basis of ratio of their responses. The knowledge of the gamma radiation quality allows to correct the response of the  $\text{CaSO}_4:\text{Dy}$  detector for the gamma contribution in the dose and to calculate the true beta dose. In the case when low energy gamma radiation is excluded, the three-element dosimeter is suitable for simultaneous measurements of beta and gamma doses.

Recently, personnel working under well known radiation conditions were supplied with dosimeter sets. The experiences collected in the practice may lead to further improvement of our routine extremity dose monitoring.

### REFERENCES

- (1) ATTIX, F. H., Health Phys. 22 (1972) 287
- (2) Measurement of short range radiations. TRS No. 150. IAEA, Vienna 1973
- (3) YAMASHITA, T. et al., Health Phys. 21 (1971) 295
- (4) Radiological protection-3. Commission of the European Communities, EUR 5358e, 1975

## DOSIMETRIC RESPONSE OF SOME BIOCHEMICALS USED AS LYOLUMINESCENT DOSIMETERS

K.V. Ettinger, R.W. Rowe, J.R. Mallard, A. Takavar and J. Sephton

Department of Medical Physics,  
University of Aberdeen, Aberdeen AB9 2ZD, Scotland U.K.

### 1. INTRODUCTION

Early investigations into the feasibility of dosimetry of ionizing radiations by lyoluminescence (1) concentrated entirely on saccharides. However, the biologically more important compounds: amino acids, proteins and nucleic acids have all been found to emit light on dissolution in distilled water or other solvents following irradiation and are also suitable for dosimetry. Like saccharides they can be closely tissue equivalent and they lend themselves particularly to studies of dose-dependent biological effects of radiation. Also to be welcomed, is the potential these materials display for ultraviolet dosimetry.

The general method of lyoluminescence dosimetry and read-out apparatus have been described previously (2).

### 2. DOSE RESPONSE TO GAMMA RADIATION

Of more than twenty amino acids in whom lyoluminescence was measured (3) the most sensitive were found to be glutamine, glutamic acid, threonine, valine and phenylalanine, whose dose response curves are illustrated in fig. 1.

Proteins (simple proteins: protamine, protamine sulphate; glycoproteins: egg albumin, bovine albumin, human albumin; enzymes: lysozyme, alkaline phosphatase, trypsin, pepsin) displayed similar dose responses (4) shown here in fig. 2.

The response of nucleic acids (in the form of sodium salt) is also linear with no sign of saturation below 400 krad. However, in antibiotics streptomycin, gentamycin and oxytetracycline the dose response is more like a saturating exponential, levelling off at around 300 krad.

Enhancement of light yield may be obtained by dissolution of the irradiated biochemicals in solutions of luminol, lucigenin or lophine. In amino acids magnifications of several thousand times were recorded which should enable detection of doses as low as 5 rad in the absence of interfering factors. An example of such interference is the presence in some samples of spurious response, even in the absence of irradiation. This is probably caused by impurities and products of decomposition.

### 3. RESPONSE TO UV RADIATION

It was found that both proteins and nucleic acids exposed to polychromatic UV radiation in the wavelength range 180 to 370 nm, but principally at 254 nm, emitted light on dissolution in proportion to the incident energy fluence up to a limiting fluence varying between 2 and 3 J.cm<sup>-2</sup> according to the material (5). Compare figs. 4 and 5. Sensitization by luminol was again observed and was shown to be linearly dependent on concentration, at least in the range 0 - 8 x 10<sup>-9</sup> mole.ml<sup>-1</sup>. However, the magnification at these concentrations was only several tens of times, but greater enhancement is certainly possible and should permit measurement of energy densities of the order of 1 mJ.cm<sup>-2</sup>.

#### 4. STABILITY OF LIGHT YIELD

Given a linear response to dose in the region of interest, the radiation effect in a solid state dosimeter must be stable to changes of temperature and atmosphere and over considerable periods of time, in order to be of use for practical dosimetry.

In amino acids the stability of light output following storage of the irradiated materials in a desiccator at room temperature has been monitored for well over a year. Valine, which is typical of the amino acids shows losses of the order of 20% per year (6). Isothermal annealing at a variety of temperatures for both short and long periods was found to slightly increase the emission. The atmospheric humidity certainly has an effect on the stability of light output, but an exposure to a very humid (90%) environment was required for many days before a significant (10%) drop in the light yield was observed. Day-light has little or no effect.

Proteins are, however, slightly sensitive to the UV component of day light. Of the proteins, protamine sulphate displayed the most constant lyoluminescence, with no decay evident after several weeks of storage at the room temperature.

UV-irradiated proteins displayed relatively rapid exponential decays of light yield, the half-times varying between tens and hundreds of hours, depending on the biochemical. In nucleic acids, on the other hand, there was a two component decay indicating the presence of two light emitting species. The initial decay is swift, with a half-time of some tens of minutes, but is succeeded by an essentially constant level of light yield for many days. Bleaching of light emitting species by visible light was observed in pepsin but not in trypsin.

#### 5. DISCUSSION

It would appear that the source of excitation leading to the emission of light are reactions of free radicals, induced by radiation in solid state. The radicals react in the solution and singlet molecular oxygen is generated in the process. Its characteristic emission has been identified by us in the spectra of lyoluminescence. In the absence of dissolved oxygen lyoluminescence disappears (6). It is, nevertheless, doubtful if transitions of the singlet molecular oxygen can explain all the features of LL spectra. (7).

ESR studies of free radicals (e.g.(8)) indicate behaviour which is consistent with the observed dose response and stability measured by means of lyoluminescence; in particular the formation of two radical species in DNA is reported, one of which decays in a few minutes, the other being relatively stable (8, 9). The Arrhenius plots of the kinetics of decay of stored radiation effect (log of light yield vs. 1/T) indicate the presence of two distinct processes, with different activation energies.

In luminol solution the radiation products catalyse an intensely chemiluminescent oxidation and in this process, which is not yet fully understood, peroxides may be involved as well as free radicals.

The detectability of the radiation damage in dry amino acids, proteins and nucleic acids by means of lyoluminescence is greater by many orders of magnitude than by any other available technique including ESR.

#### 6. CONCLUSIONS

Clearly, amino acids, proteins and nucleic acids have considerable potential for highly tissue equivalent lyoluminescence dosimetry of high

energy and UV radiations as well as for fundamental radio- and photo-chemical investigations.

By use of the appropriate biochemical, accurate determination of UV action spectra for biological tissues such as skin and cornea would be possible. For all radiations, lyoluminescence dosimetry has the particular advantages of simplicity, versatility and low cost. Similarity of the composition of tissues to the chemical composition of dosimetric biochemicals offers a degree of tissue equivalence not attained in other methods of solid state dosimetry. The lyoluminescent materials can be used as dosimeters for neutron irradiations and even for pi-meson beams. In the latter case, most of the pion energy is transferred to the medium in interactions with C,O and N nuclei. Using biochemicals as lyoluminescent phosphors there is no difficulty in matching the content of these elements with that of soft tissues.

The phenomenon of lyoluminescence can also find applications outside the field of dosimetry e.g. in the monitoring and assay of pharmaceuticals for free radicals and degradation following various preparation techniques and storage.

This work was supported by the National Radiological Protection Board. (U.K.)

REFERENCES

- (1) K.V. Ettinger and N.A. Atari. Proc. Fourth Int. Conf. Luminescence Dosimetry, Cracow 1974. T. Niewiadorski ed. Inst. Nucl. Phys. Cracow 1974. pp. 417-439.
- (2) N.A. Atari, K.V. Ettinger and J.H. Fremlin Radiat.Effects 17,450. 1973.
- (3) D.I. Thwaites, M.Sc. Thesis, University of Aberdeen, 1975.
- (4) J.P. Sephton, M.Sc. Thesis, University of Aberdeen, 1976.
- (5) R.W. Rowe, M.Sc. Thesis, University of Aberdeen, 1976.
- (6) A. Takavar, Lyoluminescence Lab. Report 1975.
- (7) G. Suchan and K.V. Ettinger "On the mechanism of carbohydrate lyoluminescence" Lyoluminescence Lab. Rept. 1976.
- (8) G. Castelain, J. Depireux and A. Müller. Int.J.Rad.Biol. 8,157. 1964.
- (9) J. Duchesne. Proc.Symp. on the Biological Effects of Ionizing Radiation at the Molecular Level. I.A.E.A.Vienna, 1962.

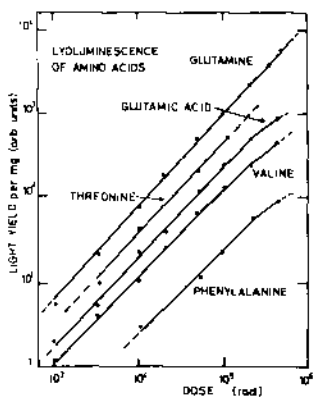

Fig. 1

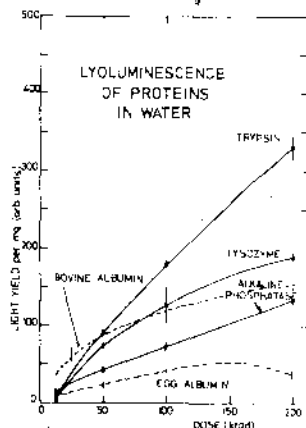

Fig. 2

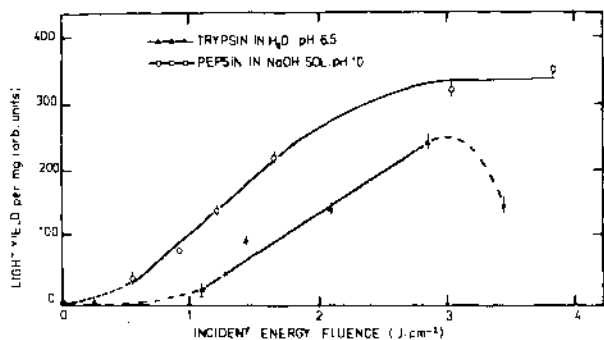

Fig. 3

LYOLUMINESCENT RESPONSE OF PROTEINS TO UV RADIATION

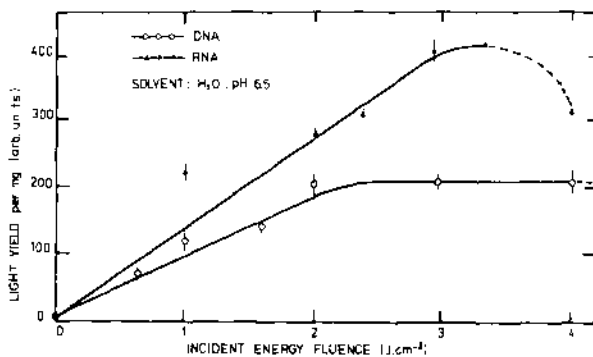

Fig. 4

LYOLUMINESCENT RESPONSE OF NUCLEIC ACIDS TO UV RADIATION

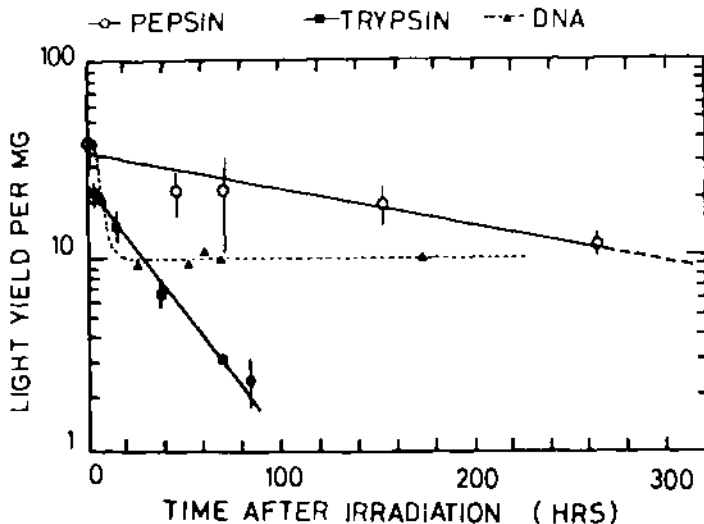

Fig. 5

Decay of free radicals in UV irradiated materials

LYOLUMINESCENCE DOSIMETRY WITH SENSITIZERS

K.V. Ettinger, A. Takavar, J.R. Mallard and G. Buchan  
 Department of Medical Physics,  
 University of Aberdeen, Scotland, U.K.

1. INTRODUCTION

It is known, that on dissolution of irradiated organic solids in water, peroxides, including hydrogen peroxide, can be found in the solution. An extremely sensitive technique of measuring minute traces of hydrogen peroxide is available (1,2,3) and has been applied to various analytical procedures (4). This technique is based on the use of luminol, (5-amino-2,3 dihydro-1,4 -phthalazinedione). The mechanism of action of luminol is still not fully understood, particularly in the case of irradiated materials. One of proposed models is shown in fig. 1.

Another sensitizer, lucigenin (N,N - dimethyl-9,9-biacridinium dinitrate) has properties similar to luminol (4,5).

We have investigated a technique of lyoluminescence dosimetry in which irradiated materials were subsequently dissolved in alkaline solutions of luminol. The emitted light was measured and integrated in a way identical with that used for lyoluminescence dosimetry in pure water (7).

2. EXPERIMENTAL

Among the materials which can be used with sensitizers are: melezitose, rhamnose, sucrose, trehalose dihydrate and aminoacids (valine, phenylalanine, cystine, threonine and glutamine).

The light enhancement in comparison with dissolution in pure water is very high and is a function of the concentration of sensitizer (Figs. 2,3 and 4). It is advisable to use water equilibrated with air because of the dependence of the light yield on the dissolved oxygen pressure (fig. 5).

The light yield is a function of temperature; fortunately for solutions of luminol there is a plateau in the range of room temperatures (fig. 6) which makes it possible to use these solutions without the need for better temperature stability than 1-2 degrees centigrade.

The light yield vs. radiation dose curves are shown in figs. 1, 7,8 and 9. The exact shape of the dose curve has not been established with satisfactory accuracy, and in particular the deviation from strict linearity appears to depend on the concentration and, perhaps, type of sensitizer. This deviation is, however, small and can be neglected in the range of doses up to 1 krad.

3. LIMIT OF SENSITIVITY

The limit of the sensitivity in measurements done with the aid of sensitizers is set by the presence of self-glow caused by an oxidation of luminol or lucigenin by the dissolved oxygen. This self-glow is a function of concentration of sensitizer and it appears that at very low concentrations of luminol the useful sensitivity limit is in the vicinity of 1 rad, frequently even lower. The self-glow changes with the alkalinity of the solution approximately in the same way as the light enhancement (figs. 10 and 11).

#### 4. SENSITIZED LYOLUMINESCENCE PHOSPHORS

The most promising technique, as yet, uses specially prepared lyoluminescent materials containing minute amounts of sensitizer. This can be achieved by crystallisation of a saccharide from a solution containing a small amount of added sensitizer.

Because of the nature of molecular lattices, it becomes incorporated in the precipitate. During dissolution the sensitizer is present "where the action is" i.e. close to the dissolving material, and causes strong light emission. After dissolution, however, the concentration of sensitizer in the bulk of the solution is too low to cause any trouble with the self-glow.

Using this technique a very high sensitivity was obtained, well below 1 rad. It is important to observe that many samples of saccharides and amino acids contain trace quantities of oxidants or other impurities causing spurious emission of light, even in the absence of irradiation. It is therefore necessary to check the lyoluminescent phosphors for the presence of these impurities by performing a blank check, before using them for dosimetry. It is also recommended to purify the luminol powder.

The luminol solutions and "luminolized" phosphors emit light centered on approx. 425 nm; the emission of lucigenin is in the vicinity of 495 nm. It permits use of an uncooled bi-alkali photomultiplier in the reader.

All other features of high sensitivity lyoluminescent dosimetry, like energy response, integrating properties, stability etc. are the same as for the lyoluminescence technique employing pure water as a solvent.

This work was performed with the support of the National Radiological Protection Board.

#### 5. REFERENCES

- (1) W.V. Mayneord, W. Anderson, K.D. Evans and D. Rosen. Radiat.Res. 3.379.1955.
- (2) M.A. Konstantinova-Schlezingher ed. "Fluorimetric Analysis", Engl. transl. from Russian. IPST, Jerusalem, 1965.
- (3) J. Kroh "Chemiluminescencja w fazie ciekłej" L.T.N. Zdz., 1960.
- (4) J.P. Auses, S.L. Cook, J.T. Maloy Analytic Chem. 47.244. 1975.
- (5) K.D. Gundermann "Chemiluminescenz organischer Verbindungen" Springer Verlag, Berlin, 1968.
- (6) J.R. Totter in "Bioluminescence in Progress", F.H. Johnson and Y. Haneda eds. pp. 23-33. Princeton University Press, Princeton N.J. 1966.
- (7) K.V. Ettinger and N.A. Atari. Proc. Fourth Int. Conf. Luminescence Dosimetry, Cracow 1974. T. Niewiadomski ed. Inst. Nucl. Phys. Cracow, 1974. pp. 417-439.

# CHEMILUMINESCENCE OF LUMINAL

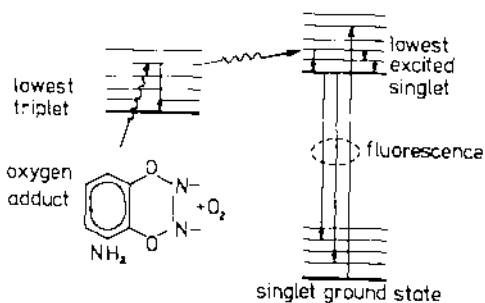

FIG. 1

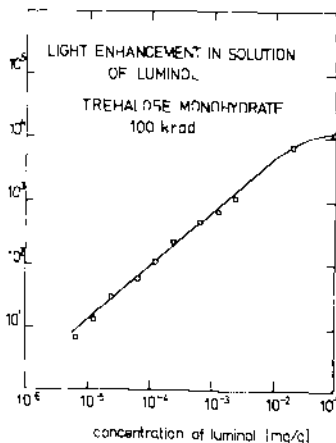

FIG. 2

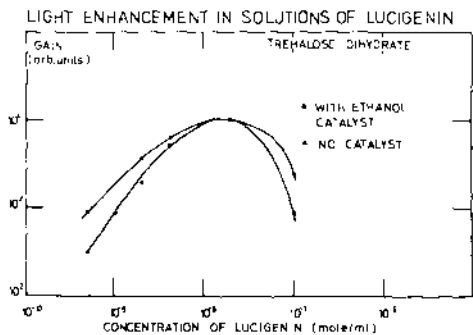

FIG. 3

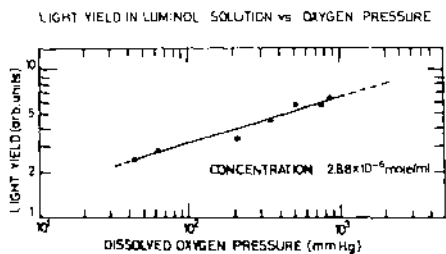

FIG. 5

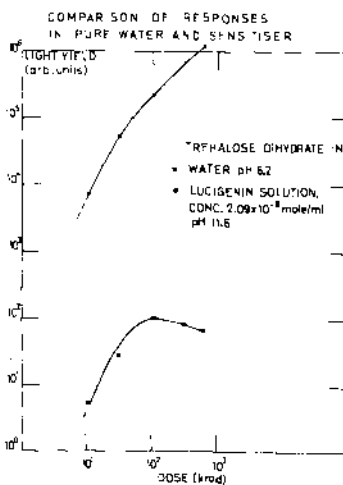

FIG. 4



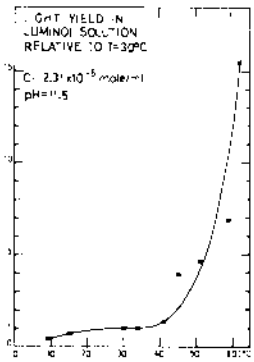

FIG. 6

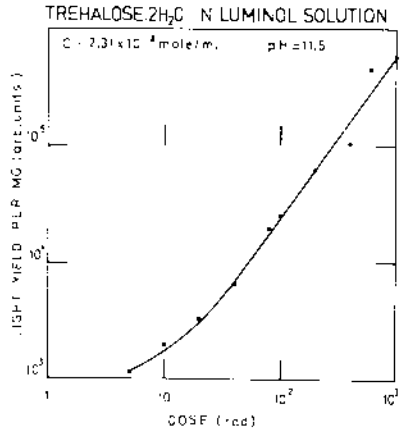

FIG 7

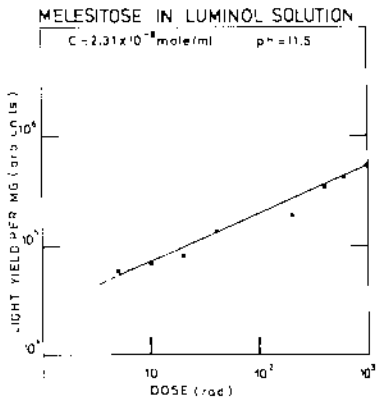

FIG. 8

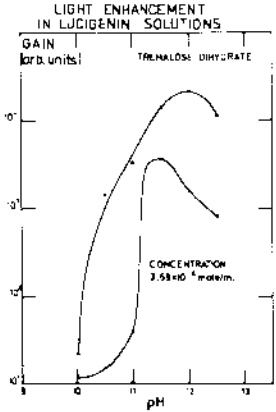
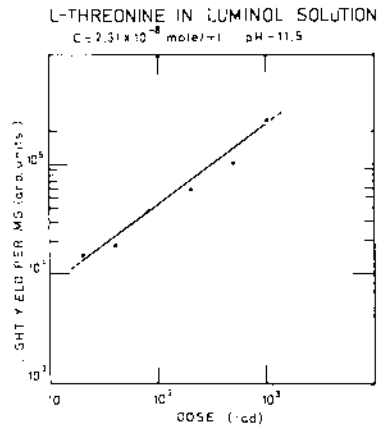

FIG. 10

FIG. 9

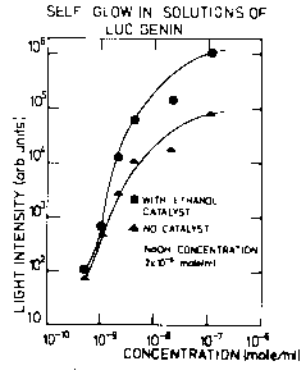

FIG. 11

PERSPECTIVES FOR USING LYOLUMINESCENCE IN PHOTON AND FAST  
NEUTRON FIELDS

K.J. Puite  
Association Euratom-ITAL, Wageningen, The Netherlands

### 1. INTRODUCTION

Dosimetry in the field of radiation protection should be performed with simple but reliable measuring systems. In this respect thermoluminescent dosimeters have already found wide application (1). In 1973 and 1974 dose measurements have been reported making use of the effect of lyoluminescence (2,3). This phenomenon has been observed when for instance saccharides, after being exposed to ionizing radiation, are dissolved in water. As the sample dissolves a light signal appears, which is a measure of the absorbed dose in the materials.

The lyoluminescence technique has also been studied at our institute with special attention paid to the behaviour of lyoluminescent material irradiated with low energy X-rays and fast neutrons. Thermoluminescent materials are in general not useful here (4,5). The results described certainly offer perspectives for future application of lyoluminescence in the field of radiation protection.

### 2. METHODS

The apparatus used for measuring the lyoluminescence (LL) signal is shown in fig. 1. A glass cup containing 15 mg of the sample is placed above the closed shutter of a photomultiplier. The cup is covered with a light tight rubber membrane. After opening of the shutter 4 ml of distilled water is injected through the membrane into the cup. The light signal which appears as the sample dissolves gives a peak during the first seconds. The integrated light output over a period of ten seconds is measured. The sensitivity of the reading system is checked regularly using a  $^{14}\text{C}$  light source. A number of saccharides as mannose, xylose and trehalose dihydrate have been tested. The mannose ( $\text{C}_6\text{H}_{12}\text{O}_6$ ) samples from Baker and BDH showed the highest sensitivity and these have been used for the measurement reported here.

### 3. MEASUREMENTS IN PHOTON FIELDS

The LL dose response curve of mannose for  $^{60}\text{Co}$  gamma rays shows supra-linearity above 300 rad and reaches a maximum at 100 krad. The dose curve below 300 rad is given in fig. 2. A linear signal versus dose relationship is compatible with the measured data. The reproducibility of the measurements, being  $\pm 3.5\%$  for doses above 200 rad, decreases at low doses. Measurements are in progress to read doses in the 100 mrad to 10 rad dose range by making use of a more sensitive LL material, an increase of the weight of the material and an optimal choice of the cup material and photomultiplier. The energy dependence of mannose has been measured down to an effective energy of 40 keV. The data are given in fig. 3, together with the theoretical curve. The energy dependence of mannose is less than that of the thermoluminescent material LiF. The fading of the LL signal at room temperature has been followed during one year. When the LL signal is plotted against the logarithm of time a straight line is obtained. During the first week following 48 h after exposure the fading amounts to 6%.

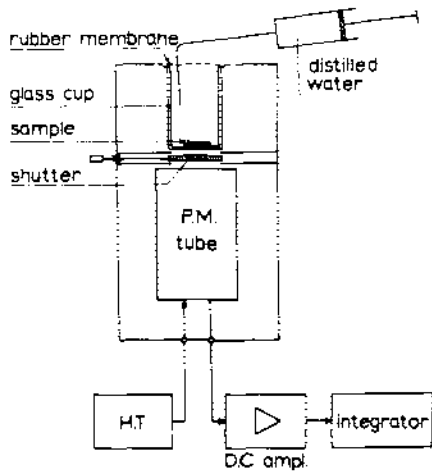

Fig. 1 Diagram of the read out system for lyoluminescence

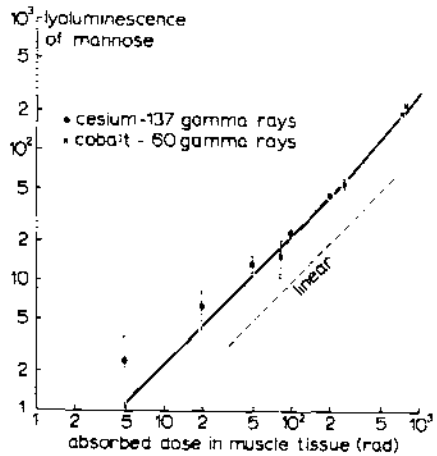

Fig. 2 Lyoluminescence dose response curve of mannose (BDH) for gamma rays at relatively low doses

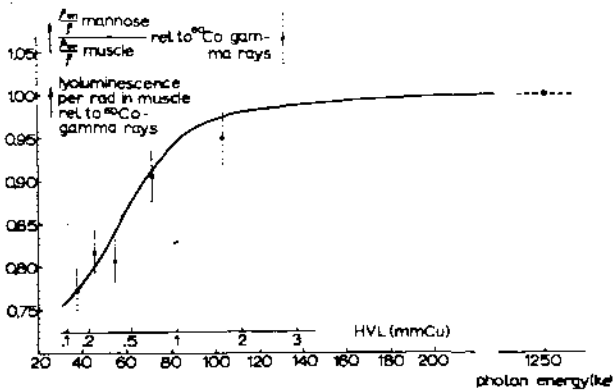

Fig. 3 Energy dependence of mannose for photons measured in X-ray beams with known effective energies at an exposure of 3 kR

#### 4. MEASUREMENTS IN FAST NEUTRON FIELDS

The dose response curves for neutrons having a degraded fission spectrum, 5.3 MeV neutrons and 15 MeV neutrons are parallel to the  $^{60}\text{Co}$  gamma curve for doses above 100 rad. After correction for the gamma contamination of the neutron beams the LL signal per rad in ICRU muscle tissue has been calculated (see Table 1). Using the kerma ratio of mannose and ICRU muscle tissue also the effectiveness of neutrons in mannose relative to  $^{60}\text{Co}$  gamma rays has been calculated. These data show a decrease at higher LET and are in general agreement with data obtained with the Fricke dosimeter (6,7) and with ESR measurements on alanine powder (8) for various neutron energies.

neutron energy	lyoluminescence per rad in ICRU muscle tissue relative to $^{60}\text{Co}$ gamma rays	effectiveness of neutrons relative to $^{60}\text{Co}$ gamma rays
degraded fission spectrum, average energy 1.7 MeV	$0.24 \pm 0.02$	$0.34 \pm 0.03$
5.3 MeV	$0.45 \pm 0.05$	$0.63 \pm 0.07$
15 MeV	$0.60 \pm 0.04$	$0.74 \pm 0.05$

Table 1. Neutron data of mannose.

#### REFERENCES

- (1) Technical recommendations for the use of thermoluminescence for dosimetry in individual monitoring for photons and electrons from external sources. Radiological Protection - 3 (Commission of the European Communities, ed.), EUR 5358 e, 1975
- (2) ATARI, N.A., ETTINGER, K.V. and FREMLIN, J.H., Radiation Effects 17 (1973) 45
- (3) ETTINGER, K.V. and ATARI, N.A., Proc. Fourth Int. Conf. on Luminescence Dosimetry (T. Niewiadomski, ed) Institute of Nuclear Physics, Krakow (1974) 417
- (4) BASSI, P., BUSUOLI, G. and RIMONDI, O., Int. J. appl. Radiat. Isotopes 27 (1976) 291
- (5) SPURNY, F., MEDIONI, R. and PORTAL, G., Nucl. Inst. and Meth. 138 (1976) 165
- (6) GREENE, D. and MILES, J. Int. J. appl. Radiat. Isotopes 27 (1976) 239
- (7) LAW, J., Phys. Med. Biol. 19 (1974) 643
- (8) SIMMONS, J.A. and BEWLEY, D.K., Rad. Res. 65 (1976) 197

STUDIES ON THE CHARACTERISTICS OF NUCLEAR TRACK SPARK COUNTING  
Hiroshige Morishima, Tacko Koga, Takeo Niwa, Hiroshi Kawai and  
Yasushi Nishiwaki\*.

Atomic Energy Research Institute, Kinki University, 3-4-1,  
Kowakae, Higashi-Osaka City, Osaka, Japan.

\* at present at the International Atomic Energy Agency,  
Vienna, Austria.

## 1. INTRODUCTION

The fission track counting method using polycarbonate sheet is known to be very effective for neutron monitoring. The detection unit consists of a track detector foil placed in contact with a thin layer of fissile material. When the unit is irradiated with neutrons, fission fragments from the fissile material layer produce scars or tracks on the detector foil. The detector foil is then etched by suitable chemical treatment to enlarge the tracks to etch-pits, which are visible under an ordinary optical microscope. However visual track counting is a tedious and time-consuming job. Automatic spark counting of etched track on the surface of the foil was initiated by Cross W. G. and Tommasino L., and is applied for neutron monitoring of some nuclear institutes or plants (1)-(4). We have investigated spark counting characteristics of above system using polycarbonate detector foils of different thickness and aluminized polyester sheets of different aluminium thickness for an electrode.

## 2. FISSILE TARGET PREPARATION

This layer of natural uranium and thorium as fissile targets for neutron detection were prepared by electroplating on stainless steel plates of 33 mm diameter (electrodeposited area of 24 mm diameter). As the fissile target for fast neutron monitoring  $^{232}\text{Th}$ ,  $^{238}\text{U}$ ,  $^{237}\text{Np}$  etc. may be used. Since the price of  $^{237}\text{Np}$  is high, and natural uranium contains a small amount of fissile nuclide  $^{235}\text{U}$ , thorium is suitable. Uranium and thorium electroplatings (10-1000  $\mu\text{g}$ ) were carried out using ammonium oxalate solution as electrolyte and ethanol at electric current density of 300 mA for uranium and 100 mA for thorium per 4.5  $\text{cm}^2$ , respectively, in a water bath at 80°C for 3 hours. And then the target discs were rinsed sufficiently. Electroplating efficiencies of uranium (500  $\mu\text{g}$ ) and thorium (500  $\mu\text{g}$ ) were about 90% and 70%, respectively at optimum electric current density.

## 3. SPARK COUNTING

Five kinds of detector foils were used for comparison, namely, Makrofol KG 5  $\mu\text{m}$ , 10  $\mu\text{m}$  and 20  $\mu\text{m}$  thick made by Bayer company in West Germany, Panlite 18  $\mu\text{m}$  thick made by Teijin company in Japan, and Lumirror 6  $\mu\text{m}$  thick made by Toray company in Japan. Makrofol KG and Panlite foils were polycarbonate and Lumirror was polyester. The foil was first placed in contact with a fissile target described above. This unit was exposed to neutrons in the UTR-B reactor (1 watt) operated at Kinki University, Osaka, Japan. The maximum thermal neutron flux in the center of the graphite in routine operation at 1 watt was about  $1.2 \times 10^7$  n/cm<sup>2</sup>.sec. The fast neutron flux was about one tenth of thermal neutron flux. However, the thermal neutron flux in the upper part of the graphite, where samples were irradiated, was about

$5 \times 10^5$  n/cm<sup>2</sup>.sec. A gold foil was irradiated with each detector foil in the reactor in order to compare and ascertain the thermal neutron flux. For the detection of fast neutron, thorium electroplated disc was used instead of uranium and calcium metaphosphate was irradiated with the unit for comparison.

After irradiation the detector foil was separated from the fissile material and immersed in a 30% KOH solution at 60°C for 20 minutes for etching. After drying, the etched detector foil was placed between the two electrodes for spark counting. One of the electrode is a copper disc of 26 mm diameter and the other is an aluminized polycarbonate sheet with the aluminized side facing the etched detector foil. The thickness of aluminium layer on the sheet is 98 Å. To punch the unperforated etch-pits on the foil, a punching voltage of about 1000 volts for Makrofol KG 10 µm thick is applied between the two electrodes. Sparks arise through the etch-pits of the detector foil. Each spark evaporates aluminium and produces a hole in the aluminized sheet, covering an area much larger than the size of the hole on the detector foil. This aluminium evaporation prevents multiple sparking through the same hole of the detector foil. As the rate of sparks during punching is too high to count with an ordinary scaler, the etched and punched detector foil is again placed on another new aluminized sheet and the sparks are counted with an ordinary scaler at a lower counting voltage.

#### 4. LINEARITY

The relation between spark count and number of fissions was approximately linear until spark counts of 700 per 4.5 cm<sup>2</sup> as shown in Fig.1. Deviation from the linear line above 700 counts may be ascribed to the resolution of scaler used.

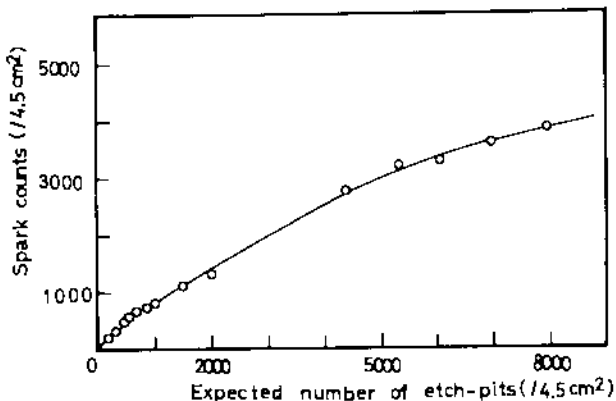

Fig.1 Relation between expected number of etch-pits and spark counts.

## 5. COMPARISON OF DETECTOR FOILS

Spark efficiencies were examined for five detector foils of different thickness as shown in Table 1. Optimum punching and counting voltages increased as the thickness of detector foils increased. It was found that spark efficiencies decreased abruptly after the foil thickness exceed 10  $\mu\text{m}$ .

Foil	Thickness ( $\mu\text{m}$ )	Punching voltage (V)	Counting voltage (V)	Spark efficiency (No of etch-Pits: 1000-2000) (%)
Makrofol KG	5	800	500	100
Lumirror	6	700	500	74
Makrofol KG	10	1000	550	77
Parlite	18	1300	800	28
Makrofol KG	20	1300	800	8.4

Table1 Comparison of detector foils.

## 6. COMPARISON OF ALUMINIZED SHEETS

Aluminium hole sizes and spark efficiencies for Makrofol KG of 10  $\mu\text{m}$  thick were examined for aluminized sheets of different aluminium thickness (27.3 - 287  $\text{\AA}$ ). Aluminium hole diameter decreases from 196  $\mu\text{m}$  (for sheets of 27.3  $\text{\AA}$ ) to 146  $\mu\text{m}$  (for sheet of 237  $\text{\AA}$ ) as the aluminium thickness increases. Spark efficiencies slightly increase several percent as the aluminium thickness increases (Fig.2).

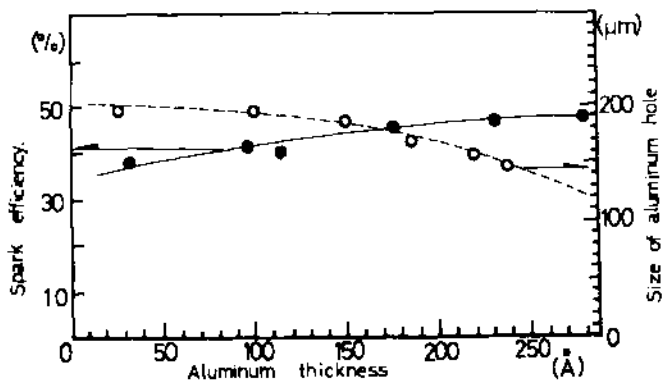

Fig.2 Relation between aluminum thickness of electrode and spark efficiency and size of aluminum hole.

## 7. CONCLUSION

As spark efficiency increases as detector foil thickness decrease, it seems that the thinnest Makrofol KG of 5  $\mu\text{m}$  thick is the best. But this is so delicate for handling that Makrofol KG of 10  $\mu\text{m}$  thick is considered to be suitable. Lumirror of 6  $\mu\text{m}$  thick is stronger than Makrofol KG of 5  $\mu\text{m}$  thick and can be used instead.

As for aluminized sheets, increase of spark efficiency is slight as the thickness of aluminium layer on the sheet increases. So any aluminized sheets are considered to be suitable, since aluminium thickness of sheets does not largely influence upon sparking characteristics.

## 8. REFERENCES

- (1) Tommasino L. and Cross W. G., Electrical detection of fission fragment tracks for fast neutron dosimeter, *Health Physics* 35 (1968) 196
- (2) Cross W. G. and Tommasino L., A rapid reading technique for nuclear particle damage tracks in thin foils, *Radiation effects* 5 (1970) 85
- (3) Prêtre S., Personal neutron dosimeter, based on automatic fission-track and spark counting, for routine and emergency use, Neutron monitoring for radiation protection purpose Vol.II, International Atomic Energy Agency, Vienna (1973) 99
- (4) Nishiwaki Y., Kawai H., Morishima K., Koga I., Okada Y., Techniques of spark counting etched nuclear tracks on plastic foils for neutron monitoring, *ibid.* (1973) 117



NEUTRON DOSIMETRY BY THE SPARK-REPLICA COUNTER  
WITH AND WITHOUT ETCHING

L. Tommasino

Lab. Dosimetria e Biofisica  
CNEN, Casaccia, Rome-Italy

## 1. INTRODUCTION

A combination of a fissile radiator and an insulating foil in which to record damage tracks represents a convenient fast neutron dosimeter. The spark-replica technique for the rapid counting of etched fission fragment holes in plastic films has removed the practical difficulties of determining low neutron doses (1). Since these neutron dosimeters provide either rad or rem response and are sensitive, simple and inexpensive, they are used in several laboratories throughout the world. On the other hand, application to measuring neutron doses by these counters is possible only for track densities lower than 3000 tracks per square cm, which corresponds to a fast neutron dose of about 10 Rads when Th radiators are used. Other drawbacks arise when good reproducibility is desired, since troublesome etching conditions are required. Furthermore these dosimeters can not provide dose measurements at the time of the exposure and dose rate evaluations when the neutron flux is time dependent, since chemical etching is required before the track detection.

This paper describes a new spark-replica counter, which helps to overcome these difficulties and avoids chemical etching, by counting electrical breakdowns initiated by fission fragment in thin film capacitors. The property that makes thin film capacitors suited for detection is that fission fragments induce breakdowns at fields distinctly lower than those due to the application of field only (2).

## 2. THE DETECTOR AND THE EXPERIMENTAL PROCEDURES

The detecting element is a thin film capacitor with a few hundreds Angstroms dielectric film and at least one electrode with thickness less than about 1000 Å. In such devices, high electrical fields are obtained at low applied voltages so that breakdowns cause limited destruction. Each breakdown produces by evaporation a hole through the insulator and through the thin electrode thus avoiding the short-circuit (3).

Fig. 1 shows how simple the breakdown detection equipment is. A resistor larger than 10 KΩ is usually placed between the power source and the capacitor to prevent large destruction by propagating breakdowns (3). This resistor can be replaced by any Geiger-Müller-type quenching circuit, capable of fast removal of the voltage from the capacitor at the time of the breakdown.

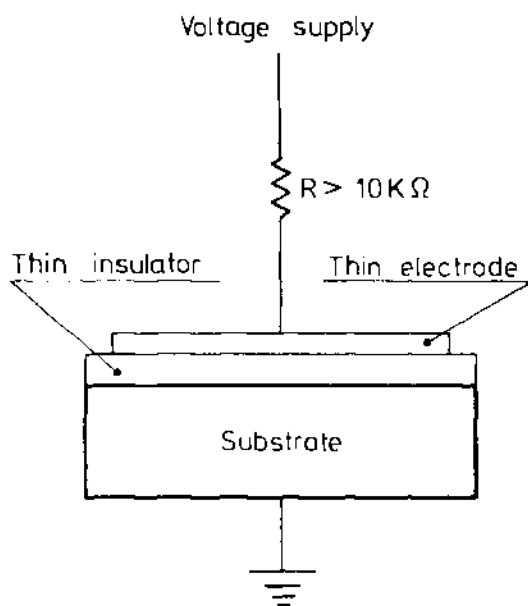

FIG. 1 Basic circuit for breakdown counting with a thin film capacitor

The electrical pulses produced by the breakdowns can be counted directly by a scaler and the evaporated spots can be observed by a reflection optical microscope. The thin film capacitors used here consisted of a degenerate p<sup>+</sup> silicon substrate with a thermally grown silicon dioxide film and a thin aluminum top electrode. The fission fragment irradiations were carried out by a thin planar <sup>252</sup>Cf source.

### 3. RESULTS

In a 380-Å-thick silicon dioxide capacitor with 150-Å-thick Al top electrode, breakdowns started occurring at applied fields above 8MV/cm. When the capacitor was irradiated with fission fragments, breakdowns occurred at relatively low electric fields. The fission fragment breakdown number versus the applied voltage, after a first steep rise, reached a plateau and it lied mostly in a range below the voltages for purely electric fields breakdowns.

At a plateau voltage of 29.5 volts the breakdown counting was equal, within statistics, to the number of the fission fragments crossing the SiO<sub>2</sub> film, as determined by counting damage tracks in a polycarbonate foil. At this applied voltage and up to 10<sup>5</sup> events per square cm of the capacitor area, there was a good proportionality between the breakdown counting and the number of fission fragments crossing the detector. The average diameter of the evaporated spots on the Al electrode was about 5 microns. With the increase of the number of breakdowns a decrease of the sample capacitance is registered, which indicates that the detector area decreased. When the breakdown counts were corrected by the capacitance losses this proportionality was extended up to millions of events per square cm of the detector area.

### 4. CONCLUSIONS

Apart from the detecting element, the thin film breakdown detector is similar to the spark-replica counter of etched-through tracks (1). With the track counter the breakdowns occur in the gas of etched holes in a few microns thick plastic film and each breakdown evaporates an aluminum spot with an average diameter larger than about 100 microns. In this case the fission fragment counting could be carried out only up to spot densities of a few thousands per square cm, which spot densities are two order of magnitude lower than those which can be detected with thin film capacitors.

For the thin film capacitors such those used here, non-shortening breakdowns cause collapse of the sample voltage within a microsecond to less 10-20 V (4). For samples between 300 and 3000 Å with breakdown voltages between 25 and 250 V, a pulse of at least a few volts is obtained at each breakdown. Such pulses do not require amplification and can be counted directly by a scaler. When compared with the track spark counter which require chemical etching before the detection, the thin film capacitors present fast time response.

A fissile radiator such a  $^{238}\text{U}$ ,  $^{232}\text{Th}$  or  $^{237}\text{Np}$  foil can be placed against the thin electrode for the detection of neutron-induced fission fragments. A simple neutron detector is thus obtained with the only requirements of a thin film capacitor, a power supply of a few tens of volts and a scaler. By modern miniaturization and processing techniques, these components could be packaged in a compact pocket-sized detecting system, which might be highly valuable for alarm neutron detection and dosimetry.

#### REFERENCES

- (1) CROSS, W.G., TOMMASINO, L., Radiat. Eff. 5 (1970) 85
- (2) TOMMASINO, L., et al., J. Appl. Phys. 46 (1975) 1484
- (3) KLEIN, N., GAFNI, H., IEEE Trans. Electron Dev. ED-13 (1966) 281
- (4) SOLOMON, P., D. Sc. Thesis, Technion-Haifa (1974)

PREPARATION AND DOSIMETRIC PROPERTIES OF BeO DISCS  
USING THERMALLY STIMULATED EXOELECTRON EMISSION

K.B.S. Murthy, C.M. Sunta and S.D. Soman  
Health Physics Division  
Bhabha Atomic Research Centre  
Bombay-400 085, India

## 1. INTRODUCTION

Dosimetry studies using beryllium oxide discs are carried out by a number of workers. After irradiation, the thermoluminescence (TL) or thermally stimulated exo-electron (TSE) output of the disc is used to find out the dose of irradiation. The TSE output of BeO discs is generally known to be quite high and doses of the order of tens of micro-roentgens can be read.

Our observations show that the density and micro-structure of the BeO discs play a significant role in the TSE output. Gemmage (1) has studied the behaviour of the BeO discs obtained from 'Brush Beryllium Co.' These discs were heated at 1450°C for nearly 600 hours, soaked in water for 100 hours and dried at 600°C for 3 hours. This treatment (2) has been reported to be essential to get high TSE sensitivity and a reasonable stability of the response to radiation exposure. These discs will be referred to as 'ORNL' discs in this paper. In our laboratory, we are making BeO discs using the cold compacting and sintering techniques. It has been possible to get increased density, larger grain size and reduced porosity. This has led to better TSE response. The dosimetric properties of these BeO discs are given in this paper.

## 2. PREPARATION OF BeO DISCS

Beryllium oxide powder obtained from 'Berylco'- U.S.A. is mixed with 1 wt.% carbowax in benzene and dried. Cold compacts are made at a pressure of 790 Kg/cm<sup>2</sup> in a 2.54 cm dia. Thickness of the cold compacts is approximately two mm. Then these are sintered at 1500°C for two hours in vacuum in a platinum wound tubular furnace. (Initial heating upto 500°C is slow to remove the binder). Finally these are resintered in air at 1400°C for 24 hours. This resulted in a density of about 2.2 gms/cm<sup>3</sup>. These BeO discs are designated 'BARC-I'.

To increase the density and the grain size in the discs designated 'BARC-II', the following procedure is adopted. The above mentioned BeO powder is dissolved in 1:1 dilute sulphuric acid at 80°C till a saturated solution is obtained. BeSO<sub>4</sub> crystallises on cooling the above solution. BeO is prepared on decomposition and calcination of BeSO<sub>4</sub> at 1000°C for three hours in air. By using this oxide and adopting the same sintering treatment as earlier, BeO discs of density 2.6 gms/cm<sup>3</sup> are obtained. Finally both types of discs (BARC-I and BARC-II) are annealed at 1400°C for 24 hours, soaked in water for 15 hours and heated at 500°C for one hour. This improved their sensitivity and also a more uniform level of response is achieved.

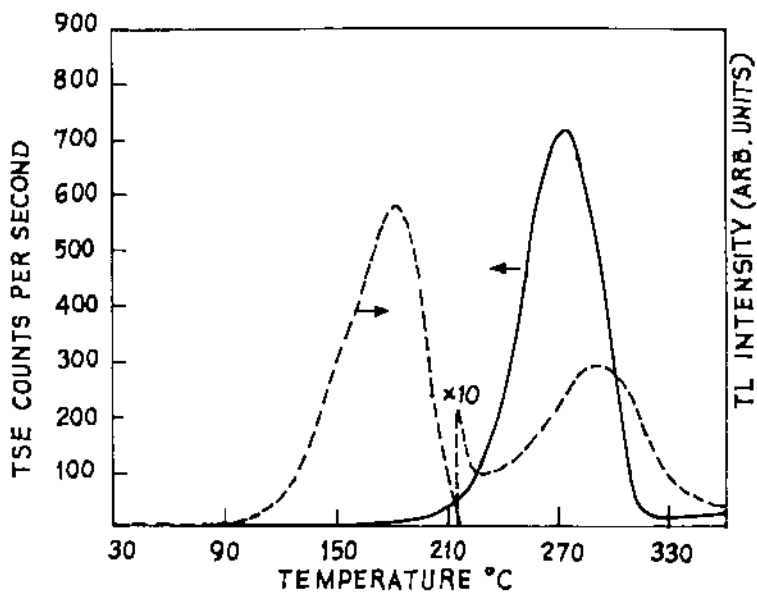

FIG.1-TSE AND TL OUTPUT OF BeO (SOLID CURVE: TSE, BROKEN CURVE: TL)

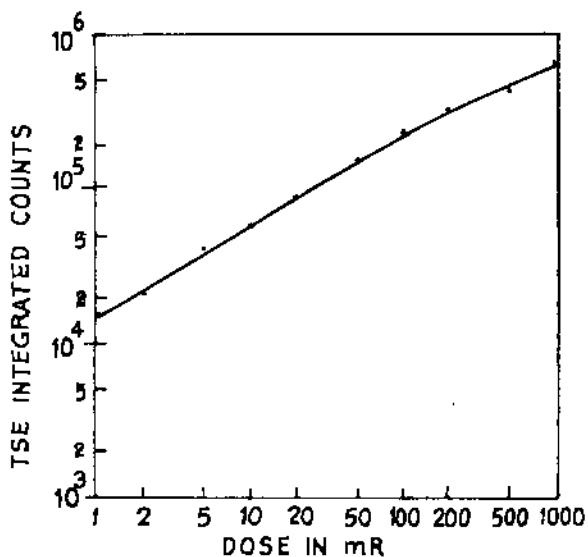

FIG.2- TSE COUNTS VS DOSE

### 3. TSEE DETECTOR

To study the TSEE phenomenon, we developed a counter, the details of which are reported in an earlier paper (3). Basically, it is a gas-flow counter operated in the Geiger-Müller region. A photomultiplier tube is mounted on the counter cathode opposite the heater position. Simultaneous TL and TSEE of samples can be recorded by this.

### 4. RESULTS

It can be seen from Table 1 given below that BARC-I and II discs have smaller grain size as well as lesser density when compared to the BeO discs obtained from ORNL. Also the TSEE output of the ORNL discs is more stable with respect to time. The higher TSEE sensitivity as well as stability are due to larger grain structure and density. Unlike the laborious treatments given to BeO discs (ORNL) to improve upon density and grain size, it is possible to reasonably increase the density and grain size in BARC-II discs compared to BARC-I by using activated BeO powder (4).

S.No.	Type of BeO disc	Density gms/cm <sup>3</sup>	Mean grain size ( $\mu$ m)	No. of TSEE counts per sq. cm. area of disc (Dose: 20 mR <sup>60</sup> Co gamma)
1	BARC-I	2.2	2	39 x 10 <sup>3</sup>
2	BARC-II	2.6	7	64 x 10 <sup>3</sup>
3	ORNL	2.8	20	93 x 10 <sup>3</sup>

TABLE 1 Values of the density, mean grain size and TSEE output of the different BeO discs.

In case of the lower density discs made by us (BARC-I), the TSEE sensitivity has fallen down by a factor of 2 to 3 in a period of nine months. But the sensitivity of the ORNL discs is fairly constant during the same period. The second batch of BeO discs with larger grain size and higher density (BARC-II) has improved sensitivity by a factor of 1.6 compared to BARC-I disc and is also fairly stable over a period of time.

4.1. Figure 1 shows the TL and TSEE output of the BeO disc. The TL glow curve is taken when the BeO disc is given a <sup>60</sup>Co gamma dose of 170R and the TSEE curve with a dose of 20 mR. For small doses there is no TL response as in case of TSEE and therefore, a high dose was to be given to record the TL glow curve. The heating rate used to record both the curves is 25°C per minute. It can be noticed that both the TL and TSEE peaks are located almost at the same temperature (275°C) whereas there is no TSEE peak corresponding to the TL peak at about 180°C.

Figure 2 shows the TSEE output versus dose curve for the BeO disc. The TSEE output is not linear in relation to the dose because at the higher count rates, counting losses become considerable. Also, when the electron density

is very high, the surface charge repels the electrons. This can be improved by keeping a grid above the disc maintained at a small positive potential to accelerate the electrons into the counting volume. We are presently engaged in providing this facility so that we can get better results.

4.2. Doses as low as 40  $\mu$ R can be read with BARG-II as well as ORNL discs.

4.3. A tribo-peak in case of TSE is observed about 60°C earlier to the TSE peak. If the discs are not handled carefully, the tribo is an interfering factor. Particularly when the disc receives jerks while handling, the tribo is increased.

#### ACKNOWLEDGEMENTS

The authors are grateful to Dr. A.K. Ganguly for his keen interest, encouragement and many discussions. Thanks are due to Dr. S.V.K. Rao and Mr. R. Bhat (Metallurgy Division, BARC) for preparation of the sintered BeO discs and to Dr. R. Krishnan and Mr. G. Eswara Prasad (Metallurgy Division, BARC) for scanning electron microscopy studies and discussions during the course of this work.

#### REFERENCES

- (1) GAMAGE, R.B. and CHEKA, J.S. "A Practical TSEE Dosimetry system based on BeO ceramic", Fourth International Symposium on Exo-Electron Emission and Dosimetry, Liblice 1973, 247.
- (2) Personal Communication of Gamage, R.B. (1975).
- (3) MURTHY, K.B.S., SUNTA, C.M. and JAIN, V.K. "Counter for thermally stimulated exo-electron studies", Indian J. of Pure & Appl. Physics 12 10(1974) 685-688.
- (4) PRASAD, G.E. and MOORTHY, V.K. "Development of crystallinity and morphology in beryllia powders during calcination and sintering", Transactions of The Indian Ceramic Society 29 3(1970) 61-71.



EXOEMISSIVE PROPERTIES OF A MIXTURE OF ALUMINIUM OXIDES IN  $\alpha$   
AND  $\beta$  PHASES : DOSIMETRY APPLICATIONS

M. PETEL\* - G. HOLZAFFEL\*\*

\* Commissariat à l'Energie Atomique, Département de Protection  
Service Technique d'Etudes de Protection, Section Technique  
d'Instrumentation et de Dosimétrie - B.P. N° 6 - 92 260  
FONTENAY-aux-ROSES - France -

\*\* Physikalisch-Technische Bundesanstalt, Institut Berlin -  
West Germany -

### 1. INTRODUCTION

In general, exoemissive materials are ionic crystals. The exoelectrons emitted from their surfaces are usually detected using a particle counter. The use of these non conductive materials produces a discontinuity in the electric field between the sample and the anode which disturbs the normal function of the detector. As such, these materials are unsuitable for radiation dosimetry since one obtains poor reproducibility.

During the last decade these difficulties have been eliminated by mixing the microcrystalline exoemitter with a powdered electrically conductive material. The most frequently used is graphite. This technique has expedited the use of reproducible exodosimeters (1,2,3).

However the realization of solid compact dosimeters by the classical procedures of compression and sintering the mixture of exoemitter and graphite, presents technological problems which are difficult to resolve.

In order to eliminate these difficulties we have replaced powdered graphite by a material having a good ionic conductivity -  $\beta$ -aluminium oxide ( $\text{Na}_2\text{O} \cdot 11 \text{Al}_2\text{O}_3$ ). The major advantage of this material is that it may be sintered (4). Our preliminary results have already been published elsewhere (5,6). We have mixed this ionic conductor with  $\alpha$ -aluminium oxide (Merck), an excellent exoemitter, which we have studied for a number of years (3,7).

### 2. MATERIALS AND METHODS

These experiments have been carried out using the TSEE\* detector and sample preparation methods described in (3). The exodosimeter comprise :

- 1) An exoemissive material : Anhydrous aluminium oxide (Merck-extra pure). This is converted to the  $\alpha$ -phase by heating in air at 1200°C (8).
- 2) A conductive material : This has been chosen after studying different  $\beta$ -aluminium oxides. The results obtained enabled selection of the following two types.

- (a)  $\beta$ -aluminium oxide ALCOA superground
- (b)  $\beta$ -aluminium oxide C.G.E. 1/30

### 3. RESULTS

Merck  $\alpha$ -aluminium oxide without addition of a conductive material (graphite or  $\beta$ - $\text{Al}_2\text{O}_3$ ) shows T.S.E.E. characteristics disturbed by electrical discharge phenomena (fig.1). These cause a deterioration of the detector anode. On the contrary, addition of  $\beta$ - $\text{Al}_2\text{O}_3$  (50 % by weight) enables one to obtain a response which is in every respect identical to that obtained with a mixture

---

\* Thermally Stimulated Exoelectron Emission.

of  $\alpha$ -Al<sub>2</sub>O<sub>3</sub> and graphite (3,7). These results demonstrate that graphite can be replaced by  $\beta$ -Al<sub>2</sub>O<sub>3</sub>.

The T.S.E.E. glow curves of the two  $\beta$ -aluminium oxides we have studied (Alcoa and C.G.E.) are shown in figures 2 and 3.

After sample preparation, triboemission is eliminated by a thermal pre-treatment at 700°C in the detector (Methane gas).

The characteristics obtained with the C.G.E. samples show a much weaker background noise than those seen with the Alcoa material. With the former the "signal to noise" ratio is increased by one order of magnitude.

In order to confirm these promising results we have studied the T.S.E.E. response as a function of the dose as seen in fig. 4. The behaviour shown is in accordance with that previously demonstrated using the  $\alpha$ -Al<sub>2</sub>O<sub>3</sub> - graphite mixture (3). We have obtained a linear response over the dose range 10<sup>-1</sup> to 10<sup>2</sup> rads (log-log plot slope 45°).

The above results have been obtained using microcrystalline aluminium oxides. Our present studies are directed towards the use of sintered exodosimeter pellets. Using the latter, preliminary results show a sensitivity\* comparable to that of the powder mixtures. However, the solidity of these dosimeters is still insufficient and must be improved. Furthermore, to gain the optimum exoemissive characteristics of these pellets, it will be necessary to study their behaviour after different thermal treatments in vacuum and controlled gas atmospheres. This work is now in progress.

#### 4. ACKNOWLEDGEMENT

The authors gratefully acknowledge Messrs Wicker and Desplanches of the Division des Matériaux du Centre de Recherche of the Compagnie Generale d'Electricité (C.G.E.) MARCOUSSIS (France) for supplying numerous  $\beta$ -aluminium oxide preparations and for their helpful discussions.

#### REFERENCES

- (1) KRAMER, J., Z. angew. Phys. 20, 411 (1966)
- (2) KRIKS, Thesis, Technische Universität Berlin, PTB Report PTB-FMRB-48 (1973)
- (3) PETEL, M., Thesis, Université Paul Sabatier, Toulouse, n° 318 (1976) Rapport CEA-R-4754 (1976) (France)
- (4) KENNEDY, J.H., SAMMELS, A.F., J.Electrochem.Soc.Electrochemical Science and Technology, Vol.119, N°12, 1609-1613 (1972)
- (5) HOLZAPFEL, G., PETEL, M., Brevet n° 76-27983, BREVATOME (France) Sept.76
- (6) PETEL, M., HOLZAPFEL, G., 5th International Symposium on Exoelectron and Dosimetry - ZVIKOV-PODHRADI- Oct.1976
- (7) HOLZAPFEL, G., PETEL, M., RODIERE, M., 4th Internat.Conf.Luminescence Dosimetry, Cracow 1974, 541-550
- (8) HOLZAPFEL, G., CRYSSOU, E., Proc.Third Internat.Conf.Luminescence Dosimetry, Risø Denmark 1971, Report n° 249

---

\* Sensitivity : the sensitivity of an exodosimeter is expressed by the number of electrons emitted from its surface by a unit dose.

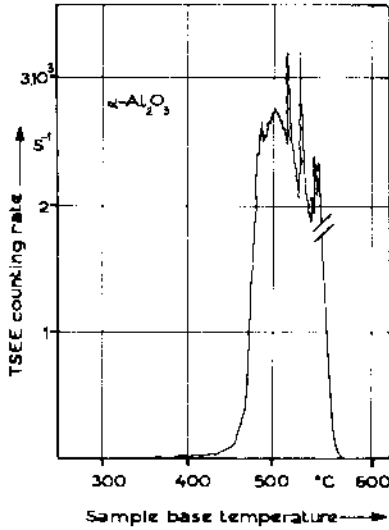

**FIG I** TSEE glow curve of  $\alpha$  alumina without any admixture

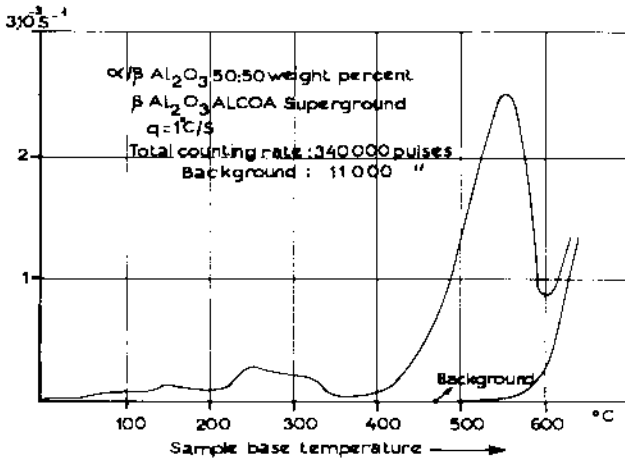

**FIG II** TSEE glow curve of  $\alpha/\beta$  alumina mixture ( $\beta$  alumina ALCOA superground)

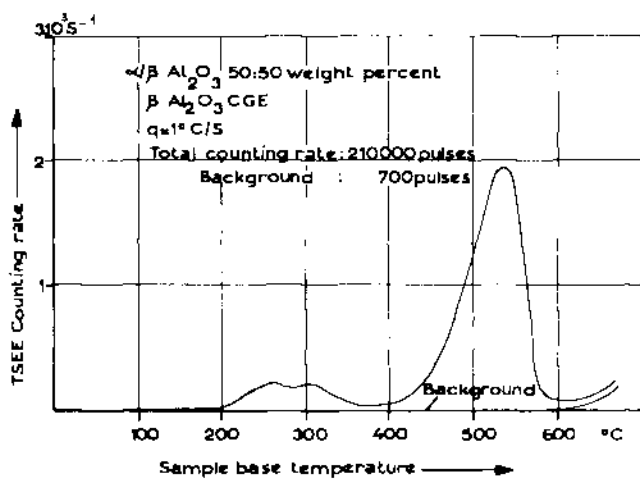

**FIG III** TSEE glow curve of  $\alpha/\beta$  alumina mixture ( $\beta$  alumina CGE)

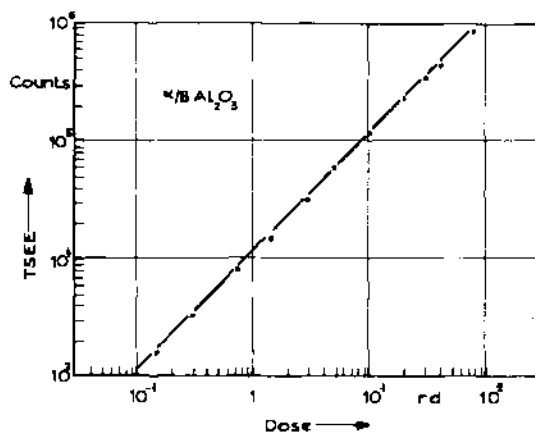

**FIG IV**  $\alpha/\beta$  alumina mixture:  
TSEE response versus increasing doses

AUTOMATISATION DU CARYOTYPE AU MOYEN D'UN APPAREILLAGE  
SPECIALISE DE TRAITEMENT D'IMAGES.

R. Le Gô, P. Saint-Jean, N. Khochtinat, B. De Cosnac.

Département de Protection  
Section de Radiopathologie  
Centre d'Etudes Nucléaires  
92260 Fontenay-aux-Roses.

Les Analyses Chromosomiques (AC) touchent actuellement un champ très vaste dans diverses disciplines médicales : Pédiatrie, Génétique, Cancérologie.....

L'estimation des dommages au niveau des chromosomes a pris en Radiopathologie, rang de Dosimétrie Biologique, grâce à des courbes de référence établies par irradiation in vitro des lymphocytes sanguins. Mais l'application de ce "dosimètre chromosomique" tend à s'étendre maintenant à des nuisances diverses : toxiques industriels, produits organiques déversés dans les eaux, etc....

Devant cette demande croissante, qu'il est impossible de satisfaire même dans le domaine médical, et ceci, du fait de la lourdeur de la technique des AC, le Service de Radiopathologie du CEA (Institut de Protection et Sécurité Nucléaire Département de Protection) a cherché à mettre au point un système destiné à accélérer les A.C, en introduisant dans leur déroulement des phases automatiques où l'ordinateur reste contrôlé par le Biologiste.

Le système d'automatisation comporte : un Automate, et un Logiciel de Calculateur.

L'Automate Spécialisé de Traitement d'Image est un ensemble de numérisation et reconnaissance de forme. Il comporte un microscope, auquel est soumis une des mitoses sélectionnées pour l'analyse. Une caméra TV balaye l'image et son signal, écrité par un seuil choisi, est numérisée et stockée dans une mémoire MOS de 32 K, après compression des blancs. L'image décompressée et recodée en analogique peut être vérifiée sur un moniteur Vidéo.

Le fichier-image stocké, comporte l'équivalent d'une grille de 400 points 300 lignes, codés sur 16 niveaux de gris.

L'Automate comporte plusieurs fonctions:

Une fonction de découpe automatique, par laquelle il délimite dans le fichier global, ce qui appartient à une seule image de chromosome. Le petit sous-fichier ou "vignette", cadrant ce chromosome, peut alors être transmis au calculateur associé, qui reçoit en outre les résultats du traitement fait par l'A.S.T.I. : surface du chromosome, surface pondérée, coordonnées d'encadrement, coordonnées dans le fichier global.

La mise en oeuvre de la fonction de découpe, peut être automatique ou manuelle : dans le mode automatique, le calculateur demande la transmission d'une vignette, reçoit le signal de fin de transmission et effectue sur ce sous-fichier les traitements de son logiciel, puis il demande la transmission de la vignette suivante..... jusqu'à la fin du fichier global.

Le mode manuel, met en oeuvre un spot lumineux (vecteur) actionné par le moyen d'un manche à balai, ce qui permet de désigner à la main, l'image à transmettre, ou bien de l'effacer du fichier par masquage temporaire. Le vecteur peut également introduire une frontière découpant une image en 2 parties indépendantes.

Le Logiciel actuellement en cours d'élaboration traite les images transmises par l'ASTI et en recherche les points caractéristiques permettant d'établir l'index centromérique de chaque chromosome. En cours de traitement, la détermination du centromère peut être vérifiée et corrigée sur l'écran de visualisation.

Lorsque tous les chromosomes de l'image ont été traités, le logiciel effectue une première classification automatique, et dessine sur écran un caryotype.

Il désigne également un fac-simile de l'image de mitose, telle qu'elle est vue au microscope, et en numérotant chaque chromosome.

Le logiciel en cours de développement, est un langage conversationnel, permettant d'introduire aisément les corrections nécessaires d'un caryotype proposé, afin de le rendre définitif.

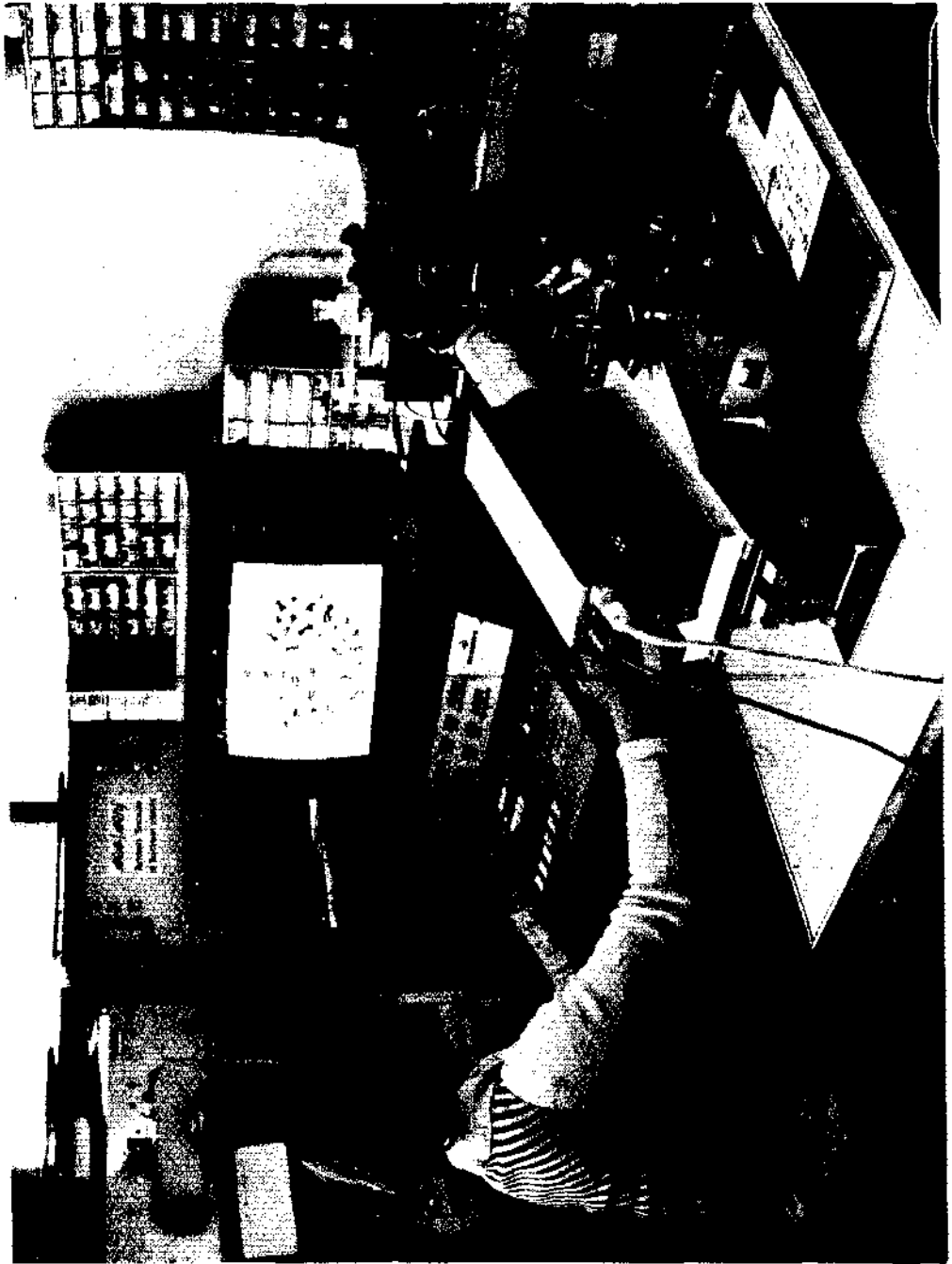

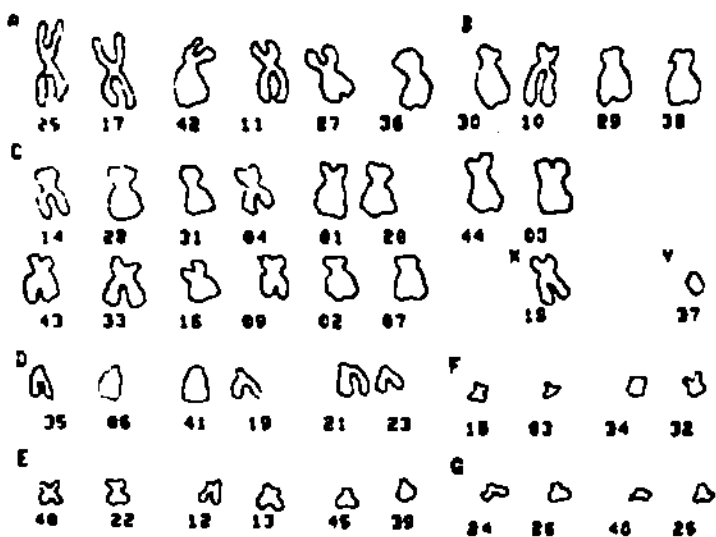

Caryotype produit par le programme après redressement des images, recherche du centromère et classement. Les numéros d'identification sont les mêmes que ceux du fac-similé.



Fac-similé de l'image microscopique des chromosomes produit par l'ordinateur après recherche des contours, et mise en place homologue dans le fac-similé.



THE EFFECT OF RADIOPROTECTORS AND IONIZING RADIATION  
ON THE cAMP SYSTEM

Yu.B.Kydryashov, A.S.Sobolev, A.N.Orekhov, Yu.Yu.Chirkov,  
E.N.Goncharenko

Moscow State University, 117234, U.S.S.R.

Studies on the radioprotection effect mechanism have led us to a concept of "increased radioresistance background" developed by the moment of irradiation (1969). It was revealed that one of the background components consists in a rise of the level of endogenous radioprotectors - biogenic amines. However, later stages of the radioprotection effect mechanism have not been sufficiently investigated. In this connection, of interest is a hypothesis of the important role of the cAMP system in the mechanism of amino-thiole radioprotection effect put forward by Langendorff (1970). The present paper provides evidence on changes in the cAMP system induced by various radioprotectors and ionizing radiations.

Such radioprotectors as serotonin, histamine and dopamine resulted in a sharp increase of cAMP concentration 1.5 minutes after the administration to Wistar male rats. Addition of the same protectors at the maximum radioprotective concentrations to adenylylate cyclase (AC) preparations proved to be highly conducive to the cAMP production by the above enzyme. In most instances, amines had no effect on the activity of cyclic nucleotide phosphodiesterase (PDE) (Table 1). AET and MEA treatment produced an increase of cAMP concentration in the tissues under study (with the peak being 10-15 min. after treatment), however the activity of AC was not affected, PDE activity being, in some cases, somewhat increased (Table 1). We suggested that an increase of cAMP level under the action of aminothioles in vivo proceeds indirectly, being induced by synthesized and released endogenous amines (Table 2, see also Mundy et al., 1961; Kulinsky, 1970).

We have observed a marked AC activation caused by amine concentrations accumulated in the tissues after MEA and AET administration. The hypothesis that the effect of sulfur-containing

Table 1

The effect of radioprotectors on the cAMP system

Radioprotector <sup>a)</sup>	Control	MEA	AET	Serotonin	Histamine	Dopamine
Tissue	cAMP (pmol per 1 mg of tissue) <sup>b)</sup>					
spleen	3.9±0.2	10.4±0.4 <sup>c)</sup>	7.8±0.4 <sup>c)</sup>	7.6±0.3 <sup>c)</sup>	7.0±0.2 <sup>c)</sup>	6.2±0.3 <sup>c)</sup>
small intestine	1.3±0.1	1.7±0.1 <sup>c)</sup>	1.8±0.1 <sup>c)</sup>	2.2±0.1 <sup>c)</sup>	2.0±0.1 <sup>c)</sup>	1.7±0.1 <sup>c)</sup>
liver	1.4±0.1	2.8±0.1 <sup>c)</sup>	2.5±0.1 <sup>c)</sup>	2.4±0.1 <sup>c)</sup>	1.9±0.1 <sup>c)</sup>	2.2±0.1 <sup>c)</sup>
	AC activity (pmol of cAMP formed per 1 mg of protein per min)					
intestinal mucosa	42.6±1.9	36.7±3.2	41.7±8.5	66.5±6.7 <sup>c)</sup>	68.4±6.8 <sup>c)</sup>	81.4±7.4 <sup>c)</sup>
spleen	14.9±1.3	16.1±3.5	15.0±2.0	19.2±1.3 <sup>c)</sup>	28.2±3.0 <sup>c)</sup>	26.0±3.3 <sup>c)</sup>
liver	9.0±1.0	7.4±1.3	9.3±1.1	12.6±1.1 <sup>c)</sup>	14.2±1.3 <sup>c)</sup>	1.8±1.5 <sup>c)</sup>
	PDE activity (pmol of cAMP hydrolyzed per 1 mg of protein per min)					
spleen	10.2±0.7	11.3±1.0	12.3±0.6 <sup>c)</sup>	10.2±0.6	11.3±0.2	6.7±0.2 <sup>c)</sup>
intestinal mucosa	10.5±0.3	12.3±0.6 <sup>c)</sup>	11.9±0.5 <sup>c)</sup>	10.0±0.4	10.7±0.2	10.6±0.4
liver	88.2±2.4	86.5±4.3	95.2±5.4	89.2±2.3	110.9±2.2 <sup>c)</sup>	78.6±3.4

a) In vivo (injection): MEA bitartrate - 400 mg/kg, AET Br·HBr - 250 mg/kg, serotonin creatinin sulfate - 400 mg/kg, histamine base - 106 mg/kg, dopamine ·HCl - 90 mg/kg; i.p. in all cases. In vitro (experiments with enzymes): MEA and AET -  $5 \cdot 10^{-3} M$ , biogenic amines -  $5 \cdot 10^{-4} M$ ;

b) 15 min after radioprotector injection; in spleen - 1.5 min after biogenic amine injection;

c)  $P < 0.05$

radioprotectors on the cAMP system is mediated by biogenic amines is supported by the following evidence: 1. sulfur-containing radioprotectors activate the synthesis and increase the level of biogenic amines; 2. in appropriate concentrations biogenic amines can activate AC; 3. the cAMP system responds faster to amine injection (1.5 min after injection ad maximum) than to a sulfur-containing radioprotector (10-15 min after injection ad maximum). Radioprotector-induced initial events in the organism cells may

take the following course: 1. sulfur-containing radioprotector activates the synthesis and release of biogenic amines; 2. injected or endogenously synthesized amines are bound by receptors; 3. AC is being activated; 4. cAMP concentration is increased in the cell; 5. in response to an increase of the cAMP level protein kinases are activated, this effect not being modulated by radioprotectors (as was shown in separate experiments). Final cAMP-caused effects (changes in the processes of DNA biosynthesis, cell division, etc.) are believed to be directly involved in the mechanism of their radioprotective action (Bacq, 1965; Langendorff, 1970). The idea of cAMP system involvement in radioprotective effect mechanisms, the fundamentals of which were laid in Langendorff's work (1970), enables one to reduce various radioprotector effects to one common cause.

Table 2.  
Content of endogenous amines ( $\mu\text{g/g}$ ) in rat tissues  
15 min after radioprotector injection

Radio- protec- tor ( $\mu\text{g/kg}$ )	Serotonin		Histamine		Dopamine	
	small intestine	spleen	liver	small intestine	spleen	
MEA(400)	$3.8 \pm 0.3^a$	$5.2 \pm 0.3^a$	-	$18.0 \pm 0.6^a$	$19.6 \pm 0.8^a$	
ABT (250)	$4.1 \pm 0.4^a$	-	$12.4 \pm 0.7^a$	-	-	
Cystamine (180)	$5.0 \pm 0.3^a$	$5.4 \pm 0.3^a$	$15.1 \pm 1.2^a$	$19.4 \pm 1.2^a$	$19.4 \pm 0.3^a$	
Control	$2.5 \pm 0.1^a$	$3.4 \pm 0.1$	$9.3 \pm 0.7$	$12.4 \pm 0.2$	$15.9 \pm 0.3$	

a)  $p < 0.01$

The existence of a variety of cAMP system controlled biochemical processes, essential to the cell, calls for investigations of the effect of ionizing radiations of the above cell regulation system since its disfunction may be one of the reasons of the cell death. Changes in the cAMP system reactivity were proved as a result of the experiment 24 hrs after irradiation. The reactivity was evaluated by a response to isoproterenol - an AC activator (Table 3). Some decrease of stimulated AC activity (1 hr after irradiation) and a drop in the PDE activity developing with time after irradiation were recorded (Table 2). It is suggested that an increased response to isoproterenol is probably due to a drop

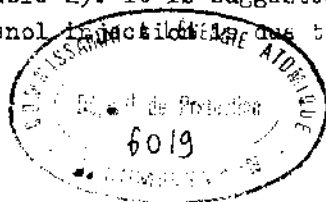

in PDE activity.

The data obtained give reason to believe that irradiation induces a disturbance of the normal cAMP reactivity which affects the correct response to the signal received by the cell from the exterior.

Table 3

Effect of X-ray irradiation (800 rad)  
on mouse liver cAMP system

	: Control :	Time after irradiation		
		: 1 hr :	: 3 hrs :	: 24 hrs
cAMP (pmol per 1 mg of tissue)				
-isoproterenol	1.1 $\pm$ 0.1	1.2 $\pm$ 0.1	1.3 $\pm$ 0.1	1.2 $\pm$ 0.2
+isoproterenol <sup>a)</sup>	7.0 $\pm$ 0.7	6.8 $\pm$ 0.7	7.1 $\pm$ 0.7	11.6 $\pm$ 1.0 <sup>b)</sup>
AC activity (pmol of cAMP formed per 1 mg of protein per min)				
basal activity	39.0 $\pm$ 1.8	35.9 $\pm$ 3.1	37.8 $\pm$ 2.6	38.8 $\pm$ 1.6
glucagon 10 ug/ml	199.9 $\pm$ 8.1	165.7 $\pm$ 6.8 <sup>b)</sup>	173.1 $\pm$ 11.2	212.8 $\pm$ 14.6
PDE activity (pmol hydrol. cAMP per 1 mg of protein per min)				
	12.5 $\pm$ 0.2	11.7 $\pm$ 0.5	10.6 $\pm$ 0.6 <sup>b)</sup>	9.5 $\pm$ 0.3 <sup>b)</sup>

a) 250 mg/kg, 2 min before decapitation

b) P < 0.05

## TO THE ACTION MECHANISMS OF BIOPROTECTORS

L.V.Alekseeva, A.A.Kudryavtzeva, V.G.Tyazhelova, I.G.Akov  
 Institute of Biological Physics, Acad.Sci.  
 USSR, Pushchino, Mosc Region, USSR,  
 142292

The analysis of the data on the action of the means of chemical protection enabled one to propose a general way of realization of the protective action of different radioprotectors (1). On the other hand, a large scatter of natural individual differences in radioresistance of a uniform population of animals (2) made one to search for physiological mechanisms responsible for these differences. To do this, two physiological states of the females markedly differing in their radioresistance were investigated. Mouse, rat and guinea-pig females proved to be more radio-sensitive in the state of active secretion of estrogens and more radioresistant (about two times) in the state of active secretion of progesteron and subliminal secretion of sex hormones (in metaestrus and diestrus) (3,4).

The studies of some metabolic and energetic processes in tissues of the females associated with the sex cycle phases have shown that in more resistant states the activity of G-6-P-D increases and the respiration of the mitochondria occurs at a low-energy level that promotes the recovery processes. At the same time the proliferative activity of all regenerating tissues of the organism decreases. The radiosensitive phases of the females have shown a decrease in activity of G-6-P-D, activation of LDH and a transition of the mitochondria to the high-energy state (activation and expenditure of reductive equivalents). At the same time an increase in the proliferating activity of different tissue systems was observed (5).

These metabolic states were modelled by means of adaptogens. It was found that the injection of ginseng and eleuterococcus over prolonged periods (a month) affects the activity of the above enzymes and energy-dependent reaction of mitochondria respiration in opposite directions. On subsequent irradiation the both adaptogens increased the survival by 20-25%. Probably more essential was not the directivity of the activation but the fact itself of activation of glycolysis and Krebs cycle on the one hand, and pentose shunt on the other. The activation of one direction of metabolism is followed by the activation of the other one. Adaptogens exert the protective action only when injected repeatedly over prolonged periods. During this time a gradual development of metabolic and energetic processes enhancing the resistance of the animals occurs.

Progesterons and estrogens responsible for significant changes in the radioresistance of the female organisms associated with the sex cycle were tested as means of chemical protection. The estrogens exert no protecting effect. On the contrary, they cause an increase in the death percentage. Progesteron proved to be a good protector. When irradiating the males 35-40 min after injection of progesteron the survival increased to 90-95% as compared to

48-50% in control. When injected to the mice 10 days before irradiation, estrogen as many other biochemical and pharmacological preparations can exert the protective effect. Despite the fact that in 48 hrs there are no traces in the organism they have time to exert the activating effect on the adaptive system and to decrease the percentage of animal death.

When injecting ACTH - adaptation hormon-15 and 30 min before irradiation, the survival rate of male mice increased to 90% as compared to 50% in control.

Upon injecting ACTH 1, 2 and 24 hrs before irradiation no protection effect was observed, the death of the animals increased. The injection of ACTH 4 hrs before irradiation gave the best result. Here survived 100% mice as compared to 48% in control.

Changes in the radioresistance were modelled also by modifying the intermediates of the Grebs cycle in order to store the energy-rich compounds for the postirradiation repair. As protectors potassium salt of the succinic and glutamic acids was tested. The protection effect did not exceed the values peculiar to bioprotectors - the survival increased to 80% as compared to 50% in control.

Hence, the bioprotectors exerting a general effect on the animal organism such as ACTH and progesteron proved to be most effective. Biological compounds causing particular limited changes of metabolism and cellular energetics such as adaptogens, Crebs cycle modifiers, the compounds activating the ACTH secretion and development of the general nonspecific resistance were found to be less effective.

#### REFERENCES

- (1) AKOEV, I.G., LACUN, M.A. Radiobiologiya, 6, (1966) 891.
- (2) AKOEV, I.G. "Problems of Postirradiation Repair", M.Atomizdat, (1970).
- (3) ALEKSEEVA, L.V., KUDRYAVTZEVA, A.A. "Peculiarities of the Radiosensitivity associated with the Sex" Radiobiologiya, number 6, v.I4 (1974), 932.
- (4) ALEKSEEVA, L.A., KUDRYAVTZEVA, A.A. "Application of Hormones as Protectors" VINITI N1858-74.
- (5) AKOEV, I.G., ALEKSEEVA, L.V. in "Theoretical Preconditions and Models of Radiation Damage of the Organism", Pushchino (1975) 151-170.

CHROMOSOME DAMAGES INDUCED BY LOW RADIATION DOSES.  
PROTECTION AND SENSIBILIZATION

E. E. GANASSI

Institute of Biological Physics, Acad. Sci. USSR,  
Pushchino, Moscow Region, USSR, 142292

The radiation-induced chromosomal structural changes are a final result of the development and interaction of many processes. One of the approaches to shed some light on the nature of these processes is a study of quantitative regularities of chemical modification of radiation damage.

The present communication is dealt with the modification of radiation damage of chromosomes at different stages of the cellular cycle. The experiments were carried out on plant and mammalian cells - seedlings of *Vicia faba* and *Crepis capillaris* and Chinese hamster fibroblasts (strain B-11d11 FAF-28) irradiated with X- or  $\gamma$ -rays at a dose rate of 20 r/min in the dose range 25 to 800 r. The chromosomal aberrations were analyzed in anaphases, early telophases or in metaphases. The material was irradiated at different stages of the cellular cycle and fixed at the times determined from radioautographic data. To study the regularities of the increase in the radiation damage caffeine ( $10^{-5}$  -  $10^{-2}$ M), chloramphenicol ( $7 \cdot 10^{-3}$ M), hydroxy-urea ( $10^{-3}$ M) were introduced before or at different times after irradiation. The experimental results showed that the increase of the damage appreciably depends on the stage of the cellular cycle, the value of radiation damage, and the time of introduction after irradiation.

So, the studies on the effect of modification on seedlings have shown that chloramphenicol induces an increase of the damage at all stages of the cellular cycle whereas caffeine increases the damage at S and G<sub>2</sub> stages and produces no sensibilizing effect at G<sub>1</sub> stage (1). The degree of the increase of the radiation damage within one stage of the cellular cycle depends on the value of radiation damage and decreases as the radiation dose increases.

The treatment with these substances causes levelling off of the radiosensitivity within the cellular cycle. For example, chloramphenicol levels the differences in the radiosensitivity of the cellular stages of *Vicia faba* seedlings whereas in the absence of chloramphenicol the cellular stages differ in radiosensitivity 1.5-2 times. The effect of caffeine on mammalian cells substantially smooths the difference in the radiosensitivity in G<sub>2</sub> and S stages that in the absence of the modifying agent differ in the yield of chromatid aberrations by one order of magnitude.

The studies of time parameters of the modification have shown that the increase of the damage at different stages of the cellular cycle can occur in different time intervals. So, in G<sub>1</sub> and G<sub>2</sub> stages the increase of the damage is possible both just after irradiation and at distant times whereas in S stage the modification period is limited by a narrow time interval after irradiation (2). This was found for both plant and mammalian

cells (3). The time parameters of the modification can be different for various compounds. For example, when irradiating the seedlings of *Vicia faba* at the postsynthetic stage of the cellular cycle it was found that chloramphenicol increases the damage throughout one hour after irradiation; caffeine acts in this time interval and is also capable of increasing the damage, when introduced at the end of the G<sub>2</sub> stage whereas hydroxy-urea increases the yield of the damages only at distant intervals and exerts no effect when introduced just after irradiation.

While studying the decreasing effect of MEA (10<sup>-3</sup>M), AET (10<sup>-3</sup>M), thymidine (10<sup>-3</sup> - 10<sup>-2</sup>M), adenosine (10<sup>-3</sup>M), it was found that the efficiency of modification also depends on the stage of the cellular cycle, value of radiation damage and the time of introduction. It was also shown the possibility of postradiation protection by means of DNA synthesis precursors. In this case the time parameters of the postradiation modification differ for various stages of the cellular cycle and correspond to the time intervals determined when studying the dependence of the postradiation increase of the damage on the time of introduction. The treatment with the protectors causes the levelling of the radiosensitivity throughout the cellular cycle as in the case of increase of the damage but at a low level of damage. Using the combined effect of MEA and AET before irradiation and caffeine and chloramphenicol after irradiation it was found that the protective action does not result in changes of the value of primary damage. The combined effect of MEA before irradiation and precursors of DNA after irradiation induce a substantial increase of the protective action as compared to the action of each compound taken separately. The analysis of the found regularities of the radiation damage modification enabled one to conclude that potential damages to the chromosomes induced by relatively low doses of radiation are retained over prolonged periods and the end yield of chromosomal aberrations depends on the repair and its modification.

The scheme of step-by-step formation of chromosome structural damages including enzymatic repair of their potential damages is proposed (3).

#### REFERENCES

- (1) GANASSI, E.E. et al. Study of modifying action of caffeine and chloramphenicol on radiation-induced chromosome damage in *Vicia faba* roots, *Radiobiologia* 13, 4 (1973) 606
- (2) GANASSI, E.E. et al. Studies of time characteristics of the irradiation damage modification of *Vicia faba* seedling chromosomes, *Genetica* XII, 4 (1976) 12
- (3) GANASSI, E.E. "Repair of chromosome radiation damages", *Studia biophysica* 53 (1975) 171



PROTECTIVE EFFECT OF HIGH CONCENTRATIONS OF VITAMIN C ON  
THE RADIATION RESPONSE OF CHINESE HAMSTER OVARY CELLS.

\*M. K. O'Connor, \*O.J. F. Malone, \*M. Moriarty,

†S. Mulgrew.

\* College of Technology, Kevin Street, Dublin 8, Ireland.

o Federated Dublin Voluntary Hospitals, Meath Hospital, Dublin 8.

† St. Luke's Hospital, Dublin 6, Ireland.

## 1. INTRODUCTION

Many chemical and physical agents have been studied with a view to determining their influence on the radiation response of mammalian cells (1, 2). Such studies have been undertaken to obtain safe reliable methods of altering radiosensitivity, and to acquire understanding of the processes involved in the development of radiation damage. The agents most frequently studied include oxygen, known radiosensitisers, metabolic inhibitors and cytotoxic drugs (1, 2, 3). Toxicity and related problems renders manipulation of many of these substances *in vivo* difficult. In contrast many substances, including common metabolites and metabolic intermediaries, whose importance in ordinary physiology is well established, have not been well studied from the point of view of their influence on radiation response. Thus while radiation protection may serve as an example of action against modern hazards, the biological base from which its practice arises is deficient in the above area. In this paper the influence of Vitamin C on the survival of irradiated CHO cells is described. A radioprotective effect is observed which may be relevant in vivo.

## 2. MATERIALS AND METHODS

The methods used are fully described elsewhere (4, 5) and are only summarized here. Chinese Hamster Ovary Fibroblasts (CHO - Clone A) grown on plastic tissue culture flasks, in Ham's F - 10 medium supplemented with 15 per cent calf serum, were used throughout. During experiments, freshly harvested cells were seeded in new flasks. After one day medium containing Vitamin C was added. Three days later radiations took place or the cells were harvested. Three hours after irradiation the cultures were removed from Vitamin C containing medium, trypsinised and reseeded at an appropriate concentration for assay of viability by cloning. Following six days incubation the clones were stained and all macroscopic colonies scored as viable. Radiations were carried out on a Stabilipan Unit (250 kVp; 190 rads/min).

Vitamin C was assayed using a modification of the method of Densen and Bowers (5, 6). The patients examined had presented for treatment of skin tumours. Biopsy specimens of normal tissues adjacent to the tumour were analysed for Vitamin C levels. Six grams of Vitamin C per day was administered to one group of patients for 7 days before assay.

## 3. RESULTS AND DISCUSSION

Fig. 1 A shows the effect of incubating CHO cells for 3 days in various concentrations of Vitamin C on cell yield. Levels up to 0.1 mg/ml have little influence. Above this the yield drops dramatically, and at 0.3 mg/ml is less than the number inoculated. Despite this, Fig. 1 B shows that the cells still attached to the flask after 3 days have not had



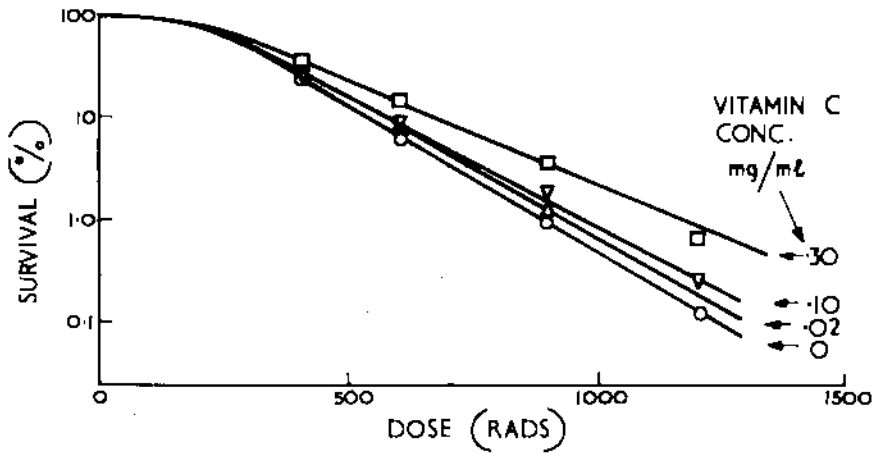

Fig. 2. Survival Curves for cells grown for 3 days in medium containing Vitamin C at the concentration indicated.

The concentrations of Vitamin C specified in the figures is that in the medium. Table 2 illustrates that tissue levels may be brought into a range that overlaps the medium concentrations at which a protective effect is observed. However the plasma level remains relatively low even in cases given large oral doses of the Vitamin. The table indicates that the levels of the Vitamin *in vivo* are susceptible to manipulation. Further work is needed to clarify whether tissue, or plasma, levels determine the magnitude of the protective effect to be expected.

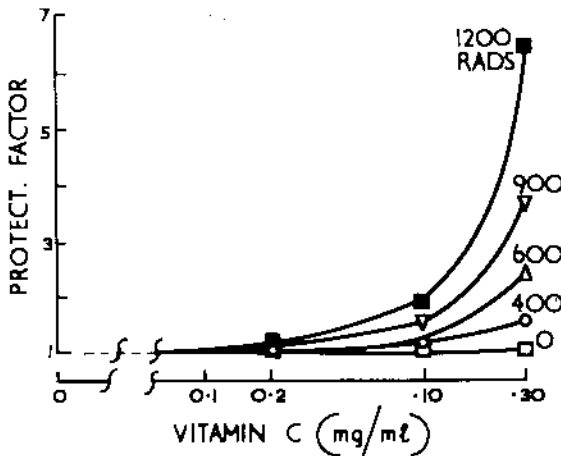

Fig. 3. Protection Factor as a function of Vitamin C concentration for various radiation dose levels.

Vit.C Conc. mg/ml.	n	D <sub>0</sub>
0.00	3.7	155
0.02	3.5	160
0.10	2.9	170
0.30	2.4	2.5

Table 1. Survival Curve Parameters.

REGIME	No. of Patients	Vitamin C Level mg/ml	
		Plasma	Normal Tissue
Home/Hospital Diet	38	0.004	0.045
Home/Hospital Diet	10	0.009	-
6 g Daily Vit.C		0.015	0.115

Table 2. Plasma and Tissue Levels of Vitamin C.

#### ACKNOWLEDGEMENTS

This work was supported by the Council of the European Communities Biology/Health Protection Programme, and the St. Lukes Cancer Research Fund. We also acknowledge the encouragement of Mr. J. K. Taaffe, and the assistance of Mr. P.A. Coughlan with dosimetry. M. O'Connor is in receipt of a postgraduate training grant from the Department of Education, Dublin.

#### REFERENCES

- (1) ADAMS, G.E. *Cur. Top. Rad. Res.* 7 (1972) 293.
- (2) DERTINGER, H., and JUNG, H. *Molecular Radiation Biology*, English Universities Press, London (1969).
- (3) BACQ, Z. M. *Chemical Protection against Ionizing Radiation*, Thomas, Springfield (1965).
- (4) O'CONNOR, M.K., MALONE, J.P. MORIARTY, M.K. MULGREW, S., *Brit. J. Radiol.* (submitted).
- (5) MORIARTY, M., MULGREW, S., MALONE, J.F., and O'CONNOR M.K., *Irish J. Med. Sci.* (in Press).
- (6) DENSEN, K.W., and BOWERS, E.F., *Clin. Sci.*, 21 (1961) 157.
- (7) SCHWERDT, P.R., and SCHWERDT, C.E., *Proc. Soc. Exp. Biol. Med.*, 148 (1975) 1237.
- (8) OMURA, H., TOMITA, Y., NAKAMURA, Y., MURAKAMI, H., *J. Faculty Agric. Kyshu University*, 18 (1974) 181.
- (9) ALA-KETOLA, L., VARIS, R., KIVINILTY, K., *Strahlentherapie*, 148 (1974) 643.
- (10) BACQ, Z.M., and FISCHER, P., *Radiat. Res.*, 7 (1957) 365.
- (11) SINCLAIR, W.K., *Cur. Top. Radiat. Res.*, 7 (1972) 264.

MODIFICATION OF RADIOSENSITIVITY OF DNA-MEMBRANE  
COMPLEXES IN MAMMALIAN CELLS BY MEANS OF PROTECTORS

N.B.Strazhevskaya, V.A.Struchkov, R.B.Strelkov,  
M.Ya.Ronin, A.Ya.Chizhov  
Institute of Biological Physics, Acad.Sci. USSR,  
Pushchino, Moscow Region, 142292, USSR;  
Brain Research Institute, USSR Academy of Medical  
Sciences, Moscow.

Besides DNA itself, the DNA-membrane complex of mammalian was found to contain firmly bound RNA, nonhistone proteins and lipids (1). This complex is shown to be stable *in vitro* to RNAase, pronase, proteinase K, trypsin, sodium dodecylsulfate, EDTA. However, when treated with phospholipase C or 35% ethanol this complex destroys to release DNA subunits with the molecular weight of  $1-2 \cdot 10^8$  daltons. The DNA-membrane complex of mammalian cells is suggested to consist of DNA subunits of  $1-2 \cdot 10^8$  dalton (about 400 subunits per one chromosome) connected with each other by lipoprotein linkers (2). Irradiation *in vivo* acts analogously with ethanol and phospholipase C: it destroys the lipoprotein linkers and releases the DNA subunits from the DNA-membrane complex, this reaction being accompanied by a very high radiation-chemical yield ( $10^5$  lipid molecules and  $10^4$  NHP per 100 eV). Therefore in the DNA-membrane complex there are specific nondeoxyribonucleotide linkers - the critical sites of a lipid nature - which are primarily damaged by radiation (2).

The physico-chemical criterion of nativlty of DNA-membrane complex is elastoviscosity which we measured on the Struchkov capillary elastoviscosimeter (3). We suggest the rapidly changes in elastoviscosity of the DNA-membrane complex in irradiated rat tissues (minutes after irradiation) to be responsible for survival of cells and the organism as a whole (4). We stated the postirradiation recovery of DNA elastoviscosity in spleen of mice irradiated with sublethal doses of 150 and 600 rad (5). The protector AET, when introduced to mice during irradiation at a dose of 150 rad, produces a marked radioprotective effect on DNA: the DNA elastoviscosity of protected mice was recovered on the third or fourth day after irradiation whereas that of non-protected - only after 14 days. The spleen of irradiated mice restored its normal weight slower than DNA its elastoviscosity.

Recently we proposed a new method of radioprotection of mammalian organisms including humans by means of a hypoxic gas mixture containing 10% oxygen and 90% nitrogen (HGM-10) (6). HGM-10 inhaled during irradiation increases survival of the animals (mice, rats, guinea pigs, dogs, monkeys). In this connection it was interesting to determine the efficiency of radioprotection of HGM-10 at the level of the DNA-membrane complex. The experiments were carried out on spleen and brain of rats. HGM-10 was found to have a pronounced radioprotective effect on elastoviscosity of DNA of rat spleen and brain upon the action of radiation at different doses (50, 200, 500, 900 rad) (7).

Simultaneously with the biochemical studies we investigated the radioprotective effect of HGM-10 on the frequency of chromosomal aberrations of monkey bone marrow and on the mitotic index of human skin cells produced by local irradiation with 100-200 rad (7). By the test "chromosomal aberrations" the coefficient of protection for bone marrow at a dose of 100 rad was 9.1 and, compared to the norm, the mitotic index for human skin cells was 3.5 and 5.5 times higher under the conditions of radioprotection with HGM-10 at doses 100 and 200 rad respectively.

Based on the facts that HGM-10, adrenaline and AET themselves produce prolonged but reversible changes in the DNA-membrane complex structure (4,7,8), these protectors are suggested to have a molecular mechanism of action. It is probable that radioprotectors and HGM-10 transfer the DNA-membrane complex into a radioresistant form by physiological mechanisms. We are now studying the nature of this transfer which is not only interesting from the theoretical viewpoint but also important for optimization of the method of radioprotection of human organism which we have already begun to use since 1975.

#### REFERENCES

- (1) STRAZHEVSKAYA N.B., STRUCHKOV V.A., KRASICHKOVA Z.I., KRUGLOVA N.L., *Studia biophysica*, 55, 73 (1975).
- (2) STRAZHEVSKAYA N.B., STRUCHKOV V.A., *Radiobiologiya* 17, No 2, (1977).
- (3) STRUCHKOV V.A., *Biofizika*, 7, 538 (1962).
- (4) STRAZHEVSKAYA N.B., STRUCHKOV V.A., *Radiobiologiya*, 2, 9, (1962).
- (5) STRUCHKOV V.A., STRAZHEVSKAYA N.B., SUSLIKOV V.I., *Radiobiologiya*, 12, 3, 435 (1972).
- (6) STRELKOV R.B., *Methods of Protection of Mammalian from Ionizing Radiation* (1971). Author Certificate on the Invention No 389549.
- (7) STRELKOV R.B., STRAZHEVSKAYA N.B., KOSICHENKO L.P., CHIZHOV A.Ya., RONIN M.Ya., KUZIN A.M., *Doklady AN SSSR*, 232, No 2 (1977). in press.
- (8) STRAZHEVSKAYA N.B., STRUCHKOV V.A., KALENDO G.S., *Radiobiologiya*, 6, 6,783 (1966).
- (9) STRELKOV R.B., *Methods of Protection of the Patient Organism from the By-Action of Ionizing Radiation in Distant Radiotherapy. Methodic Recommendations*. Moscow (1975).

## THE EFFECT OF CHEMICAL PROTECTION ON THE POSTIRRADIATION RECOVERY OF SYSTEMS RESPONSIBLE FOR "MARROW" OR "INTESTINAL" SYNDROMES IN MAMMALS

E.D. Plotnikova

Institute of Biological Physics, Acad. Sci. USSR, Pushchino,  
Moscow Region, I42292, USSR

The process of recovery of the whole organism of mice after total-body irradiation with sublethal doses has been studied by the method of split-dose irradiation with "marrow" or "intestinal" death as criteria. Male and female 12-16 week-old mice F<sub>1</sub> (CBA x C57BL) were used. Whole-body exposure to <sup>137</sup>cesium gamma rays was performed at a dose rate of 450 R/min. The second irradiation (with 3-7 doses) was given at intervals of 1 to 30 days after the first dose of 350 R or 500 R without protection or 595 R following an i.p. injection of 350 mg/kg of cysteamine-S-phosphate.

In order to study the rate of recovery the residual injury was estimated (as the difference between isoeffective doses under single or split-dose irradiation).

A comparison between the patterns of haemopoietic endogeneous CFU recovery and the whole organism recovery with "marrow" death as a criterion was done. In both cases the postirradiation recovery curves are undulating. A characteristic feature of both processes is the maximal rate of recovery within the first 24 hours. As to the population of haemopoietic stem cells, it can be interpreted by the transition of the quiescent (G<sub>0</sub>) part of the cell pool to the proliferative state. During several successive days the decrease of the residual injury level is slower, but also equal in both cases, in the interval from 4-5 to 15-16 days after irradiation the curves diverge and subsequently the difference disappears again.

Our survival data obtained from the study of "intestinal" death we compared with the data of Withers and Elkind concerning the dynamics of recovery of CFU in the small intestine. In both cases the postirradiation recovery curves are undulating and completely coincident. The small intestine crypt proliferative pool does not contain such a great fraction of quiescent cells as the haemopoietic stem cell pool. So the maximal recovery rate within the first 24 hours after irradiation in this case might be related with greater repair of sublethal cell damage. The strict coincidence of the pattern of whole organism radiosensitivity changes concerning the "intestinal" death with the pattern of crypt CFU number changes allows us to consider the crypt CFU as a substrate of the whole organism recovery for the case of the gastro-intestinal syndrome.

The divergence of analogical curves in the case of the haemopoietic syndrome in our opinion may be interpreted by the superposition of the secondary rise of residual injury in the gastro-intestinal system to the recovery process in the haemopoietic system.

Thus according to our own and reference data the postirradiation

recovery process appeared to be complex involving three stages with different cell mechanisms as a basis:

1) Rapid recovery within the first 24 hours owing to sublethal damage repair in stem cells and also by activation (in the haemopoietic system) of the quiescent cell fraction.

2) Whole repair to the initial level due to repopulation of the stem cell pool.

3) Overshot and successive undulations of radiosensitivity near the control level due to regulatory processes in stem cell pools. The different rates of recovery form a characteristic feature of the considered process. The gastro-intestinal system recovers 1,3 times more quickly than the haemopoietic system, this, apparently contributes to a greater relative radioresistance of the gastro-intestinal system (the LD 50/7 is 1,2 times greater than the LD 50/8-20).

So, the response of the organism of mammals to irradiation under moderate exposure is essentially determined by the recovery process.

In the radiation protection experiments the residual doses in the case of haemopoietic system were counted in per cents to the dose of 350 R in the control and protected animals, because the DRF was 1,7. After irradiation of protected mice with a dose of 595 R the residual injury within the first 24 hours (the first stage of recovery) is mainly the same as under irradiation of unprotected mice with a dose of 350 R. In subsequent days (the second stage of recovery) the decrease in residual injury in protected and unprotected mice is the same.

During the third stage the recovery of the protected animals leaves slightly behind the recovery of the unprotected mice and the undulations of corresponding curves are not quite synchronous. The recovery of gastro-intestinal system was studied under irradiation with the same dose. But because the DRF for the intestinal death is only 1,3 the residual doses were counted in per cents to a dose of 460 R in protected animals versus 350 R in unprotected.

After irradiation of protected mice with a dose of 595 R the residual injury becomes equal to that of unprotected animals irradiated with a dose of 350 R within the first stage of recovery. During the second stage the residual injury disappears in both cases. The subsequent dynamics of recovery was studied up to the 8th days, when the residual injury is quite different in protected and unprotected mice.

The sharp decrease of residual injury within the first 24 hours may be accounted for by that the action of the protector consists in either decreasing the primary damage during the exposure or enhancing the recovery process in stem cells of the corresponding system. The protection does not influence the second stage of the recovery process, which means, that the proliferation rate of survived stem cells is not changed.

In the third recovery stage of gastro-intestinal system of protected animals there was not registered a secondary rise of residual injury on the 7th-9th days, as in unprotected animals. A more early overshoot in this stage of haemopoietic recovery was also noted in protected mice.

The reason of this later phenomenon might be the of superposition of the secondary rise residual injury in gastro-intestinal system



to the pattern of haemopoietic recovery in unprotected animals. As the protection eliminates this secondary rise, it is naturally, that the residual injury following the pattern of haemopoietic stem cell recovery.

Thus, the observed differences in the recovery curves of protected and unprotected animals additionally confirm the cell mechanism of mammalian radiation death.

ETUDE EXPERIMENTALE DES DIFFERENTS EFFETS OBSERVES  
APRES INHALATION DE RADIOELEMENTS EMETTEURS ALPHA.  
RELATION DOSE - EFFET.

M. MORIN, R. MASSE, J.C. NENOI, H. METIVIER  
D. NOLIBE, J.L. PONCY, J. LAFUMA

CEN-FAR, DP<sup>r</sup>, SPTE  
B.P. n° 6 - 92260 FONTENAY AUX ROSES

L'étude commencée il y a six ans sur l'induction de cancers par l'inhalation de radioéléments émetteurs alpha chez près de 1.500 rats est maintenant totalement exploitable.

Nous ne rappellerons pas les techniques d'inhalation (1) et de traitement histopathologique des échantillons (2); ces méthodes ont été décrites dans de précédentes publications. Les radioéléments utilisés ont été les Plutonium 239 et 238 (oxyde et nitrate), l'Américium 241 (oxyde et nitrate), le Curium 244 (nitrate) et le thorium 227 (chlorure)(3).

Nous observons une différence selon que le radioélément inhalé se trouvait dans le poumon sous forme particulaire ou sous forme monodispersée.

Sous forme particulaire, le radioélément a une rétention pulmonaire longue et élevée, mais n'a que peu d'influence sur les autres organes; sous forme monodispersée au contraire, son temps de séjour dans le poumon est court, mais la contamination générale est importante.

Il est évident que, dans le premier cas, nous obtenons surtout des cancers pulmonaires, alors que dans le second cas, nous observons en plus l'apparition de cancers dans le squelette et les autres organes.

La dispersion rapide du 238 Pu, du 241 Am et du 244 Cm, sous la forme d'oxyde ou de nitrate, entraîne pour une même dose totale un débit de dose élevé qui raccourcit la durée de vie de l'animal et empêche le développement des tumeurs pulmonaires dont l'apparition est assez tardive. Les cancers osseux, qui ont tendance à métastaser dans l'organisme et particulièrement dans le poumon, apparaissent plus rapidement que les cancers pulmonaires; au contraire les cancers des tissus mous apparaissent tardivement et nous en trouverons davantage chez les animaux ayant reçu de faibles doses d'irradiation et ayant de ce fait une durée de vie plus longue, donc plus proche de celle des animaux témoins.

A titre d'exemple, on observe, avec le Nitrate d'Américium-241, que par rapport à la dose pulmonaire, celles des autres organes sont:

os = 0.25, foie et rein=0.1, tissus mous=0.02

- TABLEAU 1 -

Tableau 1 - Cancers pulmonaires (320 cancers)

Type histologique des tumeurs	ELEMENTS DIFFUSIBLES							NON DIFFUSIBLES	
	227 <sup>Th</sup>	238 <sup>Pu</sup>		241 <sup>Am</sup>			244 <sup>Cm</sup>	239 <sup>Pu</sup>	
	Chlorure	Oxyde	Nitrate	Oxyde	Nitrate	Nitrate + Tabac	Nitrate	Oxyde	Nitrate
1. Bronchiolo-alvéolaire (pneumocytaires II)	2	4	4	40	44	11	4	58	11
2. Bronchogénique (épithélioïde)	2	4	3	22	32	11	3	45	13
3. Sarcome	0	0	0	15	2	0	3	7	0
Incidence des cancers par rapport au nombre de rats "at risk"	17% (23)	50% (16)	58% (12)	78% (99)	52% (244)	81% (27)	37% (27)	85% (108)	80% (30)
Dose moyenne (en rad)	300	655	1295	1045	850	1165	385	3920	2975

Dans ce tableau, nous exprimons nos pourcentages en fonction du nombre de rats "at risk", c'est à dire des rats mourant après l'apparition du premier cancer. Nous ne tenons pas compte ainsi des rats morts très jeunes à la suite d'une infection. Pour un même élément, plus la dose d'irradiation est élevée, moins on trouve de cancers bronchioloalvéolaires, tandis que le nombre de cancers bronchogéniques augmente.

Les types histologiques dépendent aussi de la souche de rats utilisée. Par exemple, la fréquence des sarcomes après inhalation d'actinides est de 17% chez les Wistar et seulement de 2,5% chez les Sprague Dawley. La fréquence des sarcomes chez le rat semble d'ailleurs être liée à un caractère familial, on les trouve souvent groupés dans une même fratrie.

La localisation des tumeurs dépend peu de la distribution de dose. On trouve 0,3% de cancers des voies respiratoires supérieures avec les actinides qui se déposent dans le poumon profond, alors qu'avec le radon qui se dépose dans les voies supérieures on trouve seulement 5% de ce même type de cancer, ce qui représente tout de même un assez faible pourcentage par rapport aux autres formes de cancers (4).

- TABLEAU 2 -

Tableau 2 - Cancers extrapulmonaires (139 Cancers)

	ELEMENTS DIFFUSIBLES						NON DIFFUSIBLES	
	<sup>238</sup> Pu		<sup>241</sup> Am			<sup>244</sup> Cm	<sup>239</sup> Pu	
	Oxyde	Nitrate	Oxyde	Nitrate	Nitrate + Tabac	Nitrate	Oxyde	Nitrate
Sang	2	2	5	3	2	1	0	1
Os	0	4	14	19	8	1	0	1
Tissus Mous	3	1	18	40	13	1	1	0
Incidence des cancers par rapport au nombre de rats " at risk ".	55%	58%	37%	29%	88%	18%	3%	10%

Nous constatons sur ce tableau la très faible incidence de cancers extrapulmonaires chez les animaux ayant inhalé du Plutonium 239, et, nous retrouvons, comme dans le tableau précédent, le pourcentage très élevé de cancers avec le tabac + américium.

Après inhalation d'éléments diffusibles, 1/3 des cancers extrapulmonaires sont toujours des cancers osseux.

Avec le Plutonium-238 et le Curium-244, un second tiers est composé de cancers du sang, alors qu'avec l'Américium-241, ce second tiers se compose de cancers de la peau et de l'appareil urogénital.

L'inhalation supplémentaire de tabac multiplie considérablement les risques de cancers. Dans le poumon, le pourcentage passe de 12% pour l'Am-241 nitrate seul à 71% si on ajoute du tabac; de même le pourcentage dans les autres organes passe de 9% en nitrate seul à 74% avec le tabac dont 40% dans l'appareil urogénital qui semble particulièrement sensible à l'action combinée du tabac.

ETUDE CINETIQUE DES PHENOMENES.

1 - Evolution de la morphologie des cancers.

La mort des animaux à des temps différents pour une même dose nous a permis de constater le caractère évolutif des tumeurs pulmonaires. On observe

toujours, indépendamment de la dose, une succession d'images morphologiques qui se déroule dans le temps. L'apparition des carcinomes malins correspondant à 100% du temps d'évolution, les papillomes ou adénomes bénins apparaissent après 85% de ce temps et les adénomatoses ou les métaplasies ne sont vues qu'après 70% de ce même temps.

Le même animal peut présenter les trois étapes en différents points de son poumon. Plus la dose est élevée et plus la séquence se déroule rapidement. Chez les témoins, on observe la même séquence mais infiniment plus lente. L'irradiation se comporte donc comme un " accélérateur " d'une évolution naturelle, accélération liée à l'importance de la dose.

## 2 - Répartition des tumeurs parmi les groupes d'animaux.

Chez les témoins, tous les cancers observés l'ont été sur des animaux dont la durée de vie a été longue par rapport à la moyenne du groupe. Quand la dose d'irradiation augmente, on observe d'abord un nombre croissant de tumeurs parmi les animaux mourant parmi les plus jeunes, puis aux fortes doses, on observe de nouveau que seuls les animaux les plus âgés présentent de nouveau des cancers. Ce fait est dû à un phénomène de létalité précoce lié à la dose et dont l'action est d'autant plus importante que la dose est plus élevée.

De toute façon, on passe toujours par un effet maximum après lequel si on augmente la dose d'irradiation on ne fait que diminuer et même supprimer l'apparition des cancers; le terrain semble alors " stérilisé " et les cellules cancéreuses ne peuvent plus s'y multiplier. Cette dose à effet maximal est variable selon le radioélément. Elle se situe en dessous de 500 rads pour l'oxyde d'Américium-241, le nitrate de curium-244 et le thorium; entre 500 et 1.000 rad pour le Plutonium-238 oxyde ou nitrate, de 500 à 5.000 rad pour le nitrate d'Américium, enfin, à partir de 1.000 rad pour le Plutonium-239.

Cependant, il existe une autre composante importante qui est la sensibilité individuelle. Dans chaque série, quelques rats, morts très tôt (250 à 300 jours) présentaient des cancers déjà très évolués malgré la faible dose reçue.

## 3 - Taille des tumeurs.

T étant la taille des tumeurs pulmonaires, nous avons  $T_1 \leq 3$  mm de diamètre,  $T_2 = 3$  mm à 5 mm,  $T_3 \geq 5$  mm jusqu'à un lobe,  $T_4 \gg$  un poumon.

N 0 ou N 1 indique la présence ou non de métastases (et non d'invasions) pulmonaires dans les ganglions; P 0 ou P 1 représente l'envahissement ou non de la plèvre et du médiastin. Nous avons enfin M 0 ou M 1 selon que nous trouvons ou non des métastases pulmonaires dans les autres organes, M 2 étant employé dans le cas de plusieurs cancers de même type dans les poumons d'un même rat. (Tableau 3)

- TABLEAU 3 -

	EMETTEURS ALPHA PARTICULAIRES	EMETTEURS ALPHA EN SOLUTION
Incidence des $T_4$ et $T_3$ par rapport aux cancers totaux	53/ 134 40%	27/ 105 25%
Incidence des métastases ganglionnaires par rapport à $T_4$ et $T_3$	26/ 53 50%	4/ 27 15%
Incidence des envahissements de la plèvre par rapport à $T_4$ et $T_3$	37/ 53 70%	26/ 87 95%

Nous avons une différence de taille des tumeurs pulmonaires selon que les radioéléments émetteurs alpha ont été inhalés sous forme de particules ou sous forme de solution. Si nous calculons la moyenne des tailles pour les Plutonium-239 et 238 (forme particulaire), on obtient un indice  $T = 2.5$ , alors que pour l'Américium (solution) la moyenne de l'indice est 1.9. Les cancers sont plus gros après une inhalation de particules qu'après une inhalation de solution.

Quant la dose croît, la durée de la vie des animaux est raccourcie, et, d'autre part l'apparition des cancers est accélérée. La combinaison des deux mécanismes explique l'évolution de la taille des tumeurs suivant la dose. La vitesse de l'évolution de la taille passe par un maximum, puis décroît aux doses les plus élevées.

De même, l'invasion pleurale croît avec la dose car elle semble liée à la taille des tumeurs. Par contre, les métastases ganglionnaires sont liées à la fois à la dose et aussi au fait que le radioélément a été inhalé sous forme particulaire.

On observe aux plus faibles doses, qu'il existe un certain pourcentage d'animaux très sensibles qui présentent des cancers très précoces, très invasifs et métastasants dans les ganglions lymphatiques.

Tous ces phénomènes dynamiques et qualitatifs permettent de penser que la relation entre la dose et la fréquence des cancers ne peut pas être représentée par une fonction mathématique simple.

#### RELATIONS DOSES-EFFETS POUR LES DOSES INFERIEURES A 5.000 RAD.

Nous regardons ici le nombre de cancers supplémentaires par nombre

d'animaux " at risk ".

Pour le poumon et l'os, on n'a pas tenu compte de la fréquence naturelle qui est très faible (1 0/100), pour les cancers des tissus mous une correction a été faite tenant compte de la durée de vie des animaux et de la fréquence naturelle qui représente environ 1/3 des tumeurs observées pour la dose la plus faible (3 rads):

Poumon	=	141/166	pour	3.200	rad
		120/224	"	1.000	rad
		13/50	"	350	rad
		12/120	"	150	rad
Os	=	6/15	pour	750	rad
		28/130	"	350	rad
		4/42	"	160	rad
		3/56	"	110	rad
		2/103	"	35	rad
Tissus mous	=	20/64	"	25	rad
(19 organes)		27/276	"	3	rad

Ces données montrent qu'avec des transplantations inhalés sous forme soluble, le risque réel n'est pas seulement le cancer du poumon ni l'ostéosarcome mais aussi l'augmentation de fréquence des cancers de tous les organes. Ceux-ci reçoivent une dose plus faible, mais leur nombre étant élevé, c'est leur somme qui constitue une part importante du risque.

#### ACTION D'UN CO-FACTEUR ( le tabac ).

Dans cette expérience, trois groupes d'animaux ont été utilisés: un groupe important a inhalé du Nitrate d'Américium-241, un autre a inhalé de la fumée de cigarettes, le troisième a inhalé la somme des deux contaminants.

Le dispositif d'inhalation de fumée de cigarettes est constitué par une enceinte étanche, remplie avec de la fumée de cigarette (1 cigarette pour 50 litres). Les animaux restent dans l'enceinte 4 fois quinze minutes par jour et ceci pendant quatre mois. Ce dispositif favorise la composante gazeuse de la fumée de cigarettes au détriment de la phase particulaire.

Les résultats obtenus ont été:

- Tabac seul : 1 cancer extra pulmonaire pour 30 rats,
- Américium seul : poumon : 56 cancers pour 120 rats  
: os : 16 cancers pour 120 rats  
: tissus mous : 36 cancers pour 120 rats.
- Américium + Tabac : poumon : 22 cancers pour 30 rats  
: os : 8 cancers pour 30 rats  
: tissus mous : 13 cancers pour 30 rats.

soit chez les animaux Américium + Tabac : 43 cancers au lieu des 28 que l'on aurait dû observer avec la somme des deux toxiques.

Cet effet synergique est certainement dû à la combinaison des mécanismes d'action cancérigène des deux éléments et non à la simple additivité de probabilité de mutation.

Le tabac a, de plus, un effet sur les métastases: pour un même nombre de cancers chez des animaux n'ayant été soumis qu'à l'inhalation d'Américium-241, on aurait dû avoir pour le poumon 0.01 au lieu de 3 observés, pour le squelette 5 au lieu de 7 et pour les tissus mous 1,3 au lieu de 7.

### CONCLUSION.

Les radiations alpha ont un double effet: un effet de type initiation et un effet de type promotion. L'effet promotion qui fait intervenir une notion de vitesse de croissance semble être l'effet le plus important. Les radiations accélèrent la dynamique de phénomènes latents dans l'organisme.

La forme physico-chimique, particules ou solutions, sous laquelle se trouve le radionucléide inhalé intervient sur le phénomène "dommage-dose". La forme particulaire favorise l'extension et l'invasion des tumeurs malignes spécialement vers les chaînes ganglionnaires.

Une dose élevée augmente la vitesse d'apparition des cancers et favorise leur croissance, mais intervient aussi sur la morphologie des tumeurs; nous avons plus de cancers bronchioalvéolaires avec les faibles doses d'irradiation et plus de cancers bronchogéniques avec de fortes doses. Un autre facteur très important est la sensibilité individuelle. L'importance de ce facteur apparaît très nettement avec les faibles doses pour lesquelles ce sont souvent les animaux très sensibles qui sont porteurs de cancers. Ce facteur semble aléatoire et rend improbable l'assimilation de la relation dose-effet à une fonction linéaire.

Des résultats obtenus avec le tabac, on peut prévoir que la combinaison de l'action des radiations avec celles de certains co-facteurs chimiques aboutira à un effet de synergie importante; donc, si nous voulons dans ces cas établir des limites de sécurité valables, il nous faut connaître, pour chaque polluant le mécanisme par lequel il peut intervenir sur l'apparition des cancers.



BIBLIOGRAPHIE.

- (1) NENOT J.C., MORIN M., LAFUMA J.  
Etude morphologique et thérapeutique des contaminations respiratoires par certains actinides en solution.  
Health Physics. 20 (1971) 167
- (2) LAFUMA J., MASSE R., METIVIER H., NOLIBE D., NENOT J.C., MORIN M.  
PERRAULT R., CHAMEAUD J., SKUPINSKI W.  
Etude expérimentale des polluants radioactifs inhalés: I - Données actuelles, II - Inventaire lésionnel, III - Validité du modèle animal. Relations dose-effet.  
Communication faite au Colloque sur les réactions bronchopulmonaires aux polluants atmosphériques - Font à Mousson - Janvier 1974
- (3) MULLER W.A., NENOT J.C., DABURON M.L., LAFUMA J.  
Metabolic and dosimetric Studies after inhalation of <sup>227</sup>Rn in rats with regard to the Risk of Lung and Bone Tumors  
Rad. and Environm. Biophys. 11, 309-318 (1975)
- (4) CHAMEAUD J., PERRAULT R.  
- Communication personnelle -

EFFET DE L'ETAT IMMUNITAIRE SUR LES CANCERS PULMONAIRES  
INDUITS PAR L'OXYDE DE PLUTONIUM

D. NOLIBE, H. METIVIER, R. MASSE, J. LAFUMA

C.E.A. - DPr/LTE - BP 561 - 92542 MONTROUX CEDEX

-----

Les tumeurs pulmonaires induites par contamination n'affectent, pour une dose donnée, qu'un pourcentage variable des animaux (1) (2). Il est donc possible d'envisager l'existence de facteurs individuels conduisant à la définition d'une population à haut risque. Parmi les mécanismes supposés, l'état immunitaire de l'animal peut être une cause importante dans le développement des tumeurs. En effet une immunosuppression favorise les cancers transplantés (3) ou induits par des virus (4). Par contre les résultats obtenus lors de l'induction par des cancérogènes chimiques sont contradictoires (5) (6). En déprimant de manière définitive (thymectomie) ou transitoire (azathioprine) ou, au contraire, en stimulant les capacités immunitaires (BCG) nous avons analysé quelles pouvaient être les conséquences sur l'incidence, le type cellulaire et l'invasivité des tumeurs pulmonaires radioinduites par l'oxyde de plutonium.

MATERIEL ET METHODES

Les rats femelles et mâles sont de souche Wistar "out bred" élevés en milieu conventionnel. Les conditions d'empoussiérage par l'oxyde de plutonium ( $^{239}\text{PuO}_2$ ) ont été précédemment décrites (7). La dose délivrée aux poumons est estimée en rads.

Les animaux thymectomisés sont opérés moins de 24 heures après la naissance, l'absence de thymus est contrôlée histologiquement à l'autopsie. Soixante dix animaux thymectomisés et contaminés sont comparés à deux lots témoins soit uniquement thymectomisés (17 animaux) soit exposés mais non thymectomisés (43 animaux + 195 animaux (2) utilisés en raison de la parfaite similitude des deux lots).

Les modifications temporaires de l'état immunitaire des animaux ont été réalisées en soumettant les animaux pendant quatre mois, à dater du jour de l'inhalation, soit à un immunodépresseur : azathioprine (Imurel-Wellcome) 5 mg/kg, per os tous les dix jours, soit à un immunostimulant : BCG lyophilisé (Pasteur) 0,4 mg/kg tous les 15 jours. Le BCG est administré soit par voie sous cutanée (43 animaux dont 3 sont encore vivants) soit par voie intratrachéale (39 animaux). Ces animaux sont comparés à des lots témoins recevant les mêmes traitements, sans plutonium.

Les diagnostics de pathologie pulmonaire sont effectués à partir des poumons coupés in toto. Les métastases ainsi que les cancers extrapulmonaires sont décelés à l'autopsie et confirmés histologiquement. La taille des tumeurs pulmonaires ( $T_1 \leq 2$  mm,  $T_2$  2 à 5 mm,  $T_3 > 5$  mm ou plusieurs et  $T_4$  un poumon) l'invasion de la plèvre ou des ganglions locaux sont définies histologiquement pour chaque tumeur pulmonaire observée.

RESULTATS

1) Incidence des tumeurs

Les résultats obtenus figurent sur le tableau I. Le pourcentage d'animaux portant soit des cancers thoraciques, y compris sarcomes lymphatiques, soit des cancers extrathoraciques est exprimé par rapport au nombre d'animaux

à compter de l'apparition du premier cancer (animaux "at risk"). Afin de contrôler l'homogénéité des groupes, doses et survies moyennes sont calculées pour chaque lot.

L'immunodépression définitive ou temporaire augmentent l'incidence tumorale de manière non équivoque pour les doses élevées (> 5000 rads). Par contre l'augmentation observée à dose moyenne est d'interprétation plus délicate en raison de la survie accidentellement trop faible du groupe témoin. L'augmentation observée pourrait être en relation avec la survie moyenne supérieure dans le lot traité. A faible dose (< 1000 rads) aucun effet n'est mis en évidence.

L'action d'un immunostimulant type BCG produit dans les mêmes conditions un accroissement du nombre de tumeurs pulmonaires. Ce résultat est particulièrement net lorsque le BCG est délivré localement par voie intra trachéale : incidence augmentée de 50% bien que la survie moyenne ait diminuée d'un facteur 2.

L'accroissement du nombre de tumeurs extra pulmonaires très significatif dans chaque lot lorsque le temps de survie est suffisamment long (doses moyennes et doses faibles) doit être interprété en fonction des résultats obtenus chez les témoins (tableau 2).

Ceux-ci montrent une augmentation significative des tumeurs extrapulmonaires spontanées après immunodépression et à moindre degré après immunostimulation répétée par voie générale.

## 2) Type cellulaire

L'analyse histologique des tumeurs pulmonaires apparues dans les différents lots (tableau 3) indique chez les animaux immunodéprimés, une augmentation du pourcentage de tumeurs épidermoïdes et sarcomateuses au dessus de 1000 rads. A faible dose on ne note qu'une augmentation des sarcomes.

Le BCG n'entraîne également que peu de modifications, à l'exception de la fréquence plus élevée de sarcomes.

## 3) Invasivité

Pour des doses et des temps de survie comparables on enregistre un accroissement de la taille et du pourcentage de cancers pulmonaires envahissant la plèvre et les ganglions locaux (tableau 4). Cette action est valable pour les deux types de tumeurs étudiées. L'invasion ganglionnaire augmente de plus de 100% après thymectomie ou azathioprine et demeure en relation avec l'accroissement de la taille des tumeurs. L'introduction du BCG par voie cutanée favorise de façon comparable l'invasivité des tumeurs pulmonaires étudiées.

## DISCUSSION

Il a été montré qu'un certain nombre de tumeurs induites chimiquement portaient des "néoantigènes", de ce fait leur développement pouvait être en partie sous contrôle immunitaire. Un tel processus a été vérifié dans le cas d'adénomes pulmonaires induits par le benzanthracène (8). Les résultats obtenus après inhalation d'oxyde de plutonium montrent également qu'une déficience immunitaire, même pendant une période limitée de la phase de latence, favorise l'apparition de tumeurs pulmonaires. Cette augmentation de l'incidence tumorale est mise en évidence aux doses moyennes et fortes, mais non à dose faible.

On peut penser que l'ablation thymique (9) de même que l'azathioprine (10) simulent les processus naturels de vieillissement immunologique et favori-

sent la croissance tumorale en déprimant principalement l'immunité à médiation cellulaire.

Outre cette action sur l'incidence des tumeurs pulmonaires induites par le rayonnement  $\alpha$ , thymectomie et immunosupresseurs favorisent l'apparition de tumeurs sarcomateuses probablement par un processus de stimulation antigénique chronique.

L'augmentation de l'incidence sous l'action des immunosupresseurs est accompagnée d'une modification des types cellulaires et une augmentation de l'invasivité. La fréquence plus élevée des tumeurs épidermoïdes peut s'expliquer par les différences d'antigénicité (6) tandis que l'augmentation des tumeurs lymphoïdes est liée à une stimulation antigénique classique.

Parallèlement on note un accroissement de l'invasivité mesurée par la taille, l'envahissement pleural ou ganglionnaire. Ce dernier point nous paraît particulièrement significatif en raison du rôle cytotoxique joué par les ganglions satellites des tumeurs (11).

Les effets facilitants obtenus après immunostimulation sont à rapprocher des travaux de BALNER (12) montrant que le BCG favorise le développement de tumeurs antigéniques. Par ailleurs les meilleurs résultats obtenus lorsque le BCG est en contact direct avec les lésions tumorales pourrait expliquer la plus faible invasivité observée lorsque la stimulation est locale. Toutefois l'incidence demeurant élevée, cette inhibition peut être également due aux modifications du tissu pulmonaire induits par l'injection intra trachéale du BCG. En particulier le passage lymphatique de cellules tumorales ou la migration des macrophages vers les ganglions pourraient être modifiés dans de telles conditions.

Ces résultats laissent penser que l'apparition de tumeurs n'obéit pas à un phénomène aléatoire en seule relation avec la dose, des facteurs individuels peuvent modifier l'incidence et la capacité invasive des tumeurs observées.

#### REFERENCES

- (1) LAFUMA J., NENOT J.C., MORIN M., MASSE R., METIVIER H., NOLIBE D., SKUPINSKI W., Respiratory carcinogenesis in rats after inhalation of radioactive aerosols of actinides and lanthanides in various chemical forms, "Experimental lung cancer carcinogenesis and bioassays, KARBE E., PARK J.F., Springer Verlag Berlin (1974) 443-453.
- (2) METIVIER H., MASSE R., NOLIBE D., LAFUMA J., 239PuO<sub>2</sub> aerosol inhalation with emphasis on pulmonary connective tissue modifications., Inhaled Particles and Vapours IV. Proceedings of 4<sup>th</sup> International Symposium on Inhaled Particles and Vapours - Edinbourg 22-26 Sept. (1975) Pergamon Press Oxford (sous presse).
- (3) CERILLI G.J., TREAT R.C., The effect of antilymphocyte serum on the induction and growth of tumor in the adult mouse, *Transplantation* 8 (1969) 774-782.
- (4) ALLISON A.C., FRIEDMAN R.M., Effects of immunosuppressants on Shope rabbit fibroma, *J. Natl. Cancer Inst.* 36 (1966) 859-864.
- (5) MILLER J.F.A.P., GRANT G.A., ROE F.J.C., Effect of thymectomy on the induction of skin tumours by 3-4 benzopyrene, *Nature* 199 (1963) 920-922.
- (6) BALNER H., DERSJANT H., Neonatal thymectomy and tumor induction with methylchloranthrene in mice, *J. Natl. Cancer Inst.* 36 (1966) 513-521.
- (7) METIVIER H., RATEAU G., MASSE R., NOLIBE D., Description d'un dispositif permettant la contamination d'animaux de laboratoire par inhalation

d'aérosols radioactifs, Note CEA-N-1722 (1974) 14p.

- (8) TRAININ N., LINKER-ISRAELI M., SMALL M., BOIATO-CHEN L., Enhancement of lung adenoma formation by neonatal thymectomy in mice treated with 7-12 dimethylbenzanthracene or urethan. Int. J. Cancer, 2 (1976) 326-336.
- (9) DABROWSKI M.P., Further studies on the properties of lymphocytes from aging neonatally thymectomised rats., Transplantation 18 (1974) 531-537.
- (10) OTTERNESS G., HAN CHANG Y.J., Comparative study of cyclophosphamide, 6-mercaptopurine, azathiopurine and méthotrexate. Relative effects on the tumoral and the cellular immune response in the mouse., Clin. Exp. Immunol., 26 (1976) 346-354.
- (11) FISHER B., SAFFER E., FISHER E.R., Studies concerning the regional lymph node in cancer. IV. Tumor regional inhibition by regional lymph node cells. Cancer 33 (1974) 631-636.
- (12) BALDWIN R.W., PIMM M., BCG immunotherapy of rat tumors of defined immunogenicity., Natl. Cancer Inst. Monogr., 39 (1973) 11.

Remerciements.

Nous remercions Mesdames BEAUVALLET et L'HULLIER et Monsieur DISCOUR pour leur assistance technique.

TREITEMENT APRES P <sub>0</sub>	LOT	ANCIENNETÉ "AT RISK"	DOSE MOYENNE (rads)	SURVIE MOYENNE (Jours)	% ANCIENNETÉ AVEC CANCERS NON THYMOCTOMIE	CANCERS THYMOCTOMIE
C	A*	27	9500	386	0	18
	B*	40	7700	486	2	47
	C*	24	600	730	8	33
THYMECTOMIE	A	15	11800	590	7	57
	B	24	2100	830	12	82
	C	18	150	590	22	28
IMUREL	A	12	10600	420	0	75
	B	8	7300	670	12	21
	C	17	440	640	4	35
SC	A	5	6600	470	0	83
	B	8	2000	740	12	82
	C	13	530	720	4	31
BCG	A	6	8400	140	0	67
	B	9	1700	590	11	78
	C	20	780	810	10	20

\*lot A = 5000 rads, \* lot B 1000-5000 rads, \* lot C = 1000 rads.

TABLEAU 2

TREITEMENT APRES P <sub>0</sub>	LOT	POURCENTAGE CANCERS PULMONAIRES	% DES DISTALMENTS TYPES	EPID.	SR. ALV.	SABC
C	A	22	69	31	0	16
	B	31	82	52	16	16
	C	9	32	58	11	11
THYMECTOMIE	A	11	82	9	9	9
	B	7	54	23	23	23
	C	5	20	60	20	20
IMUREL	A	9	28	22	0	0
	B	8	50	50	0	0
	C	9	32	32	33	33
SC	A	6	67	33	3	3
	B	8	25	50	25	25
	C	4	25	75	0	0
BCG	A	4	50	50	0	0
	B	7	43	67	0	0
	C	5	20	80	0	0

TABLEAU 3

TUMEURS	ANNUITE		MORTALITE SDS (Jours)	ANCIENNETÉ AVEC CANCERS (en %)
	MORTS	VIVANTS		
0	27	3	846	7
THYMECTOMIE	11	6	810	27
IMUREL	12	6	766	17
SC, BCG	23	1	813	13
ET, BCG	23	2	823	9

TABLEAU 2

TREITEMENT APRES P <sub>0</sub>	TARE	SURVIE MOYENNE	DOSE MOYENNE	TAILLE MOYENNE P. CENTRALE	INVASION (en %)	CANGLIONNAIRES
0	Epid.	490	4800	2,6	48	16
	Sr. Alv.	666	3200	1,8	26	73
THYMECTOMIE	Epid.	500	8300	1,3	68	32
	Sr. Alv.	695	2700	2,4	38	24
IMUREL	Epid.	320	3300	2,7	83	42
	Sr. Alv.	695	4400	2,4	67	31
SC	Epid.	410	4900	1,6	86	57
	Sr. Alv.	695	2700	2,7	67	33
BCG	Epid.	564	3900	2,7	50	33
	Sr. Alv.	495	3200	1,9	30	0

TABLEAU 4

THE ROLE OF ANIMAL TOXICITY STUDIES IN THE  
EVALUATION OF HUMAN HEALTH RISKS FROM  
INTERNALLY DEPOSITED TRANSURANICS

Roy C. Thompson

Biology Department  
Battelle, Pacific Northwest Laboratories, Richland, WA 99352 USA

The extrapolation of animal data to man has always been a problem for those concerned with human biology. Especially if one is interested in the effects of toxicants, opportunities for direct observation in man are usually limited, and approval of planned experiments employing human subjects is difficult to obtain. In no case are these limitations more restrictive than for transuranic elements, for which no life-threatening effects have yet been demonstrated in man. This lack of human experience is coupled with a massive public concern over possible future effects of transuranics, which contrasts sharply with the general public apathy toward a multitude of present environmental pollutants of clearly established toxicity.

This concern for the transuranics and for other radionuclides has prompted the expenditure of many millions of dollars (and francs and marks and pounds and roubles) on studies to investigate their toxicity in animals. Results of these studies are extensive, and still accumulating, but in many quarters there is now a reluctance to accept these results as relevant to the prediction of human effects. Thus we find that estimates of health effects from transuranics, in the United States at least, are based primarily on the estimates of cancer risk vs. radiation dose as compiled in the BEIR Report (1). The BEIR Report estimates of bone cancer risks are derived from human experience with radium and external X-irradiation; the lung cancer risks are derived from human experience with radon and radon daughters in mines and from external X- and neutron-irradiation. The BEIR Report relates bone cancer risk to average radiation dose to bone, which is not pertinent to transuranic distribution, and relates lung cancer risk to bronchial radiation dose, which is also not pertinent to transuranics. I would argue that the extensive animal data on actual effects of transuranic elements -- whatever the problems of interspecies extrapolation -- are more apt to provide meaningful predictions than are the human data.

Part of the problem with animal data may be that they are less convincing to the general public because the uncertainties are more obvious. It is clear to everyone that a man is not a mouse. It is not so clear to everyone that when one calculates an average radiation dose to lung, this in no way describes the pattern of exposure from inhaled plutonium. It is also true, I believe, that the radiation protection fraternity is less familiar, and therefore less comfortable, with interspecies extrapolation than with esoteric dose calculations -- even if these doses are calculated for the wrong tissues.

The problem of extrapolation between species has received much attention in other fields. It has recently commanded increased attention in the specific area of internally deposited radionuclide effects (2). Very often, however, such efforts focus on quantitative conclusions, to the neglect of qualitative wisdom. I would maintain that it is more important to gain a general impression in which one has complete confidence, than a specific "answer" in which one has little confidence.

From animal studies with transuranics, I believe we have gained at least two "general impressions" in which we can have confidence. One of these is that the transuranics are, indeed, very carcinogenic when inhaled or injected, and that extreme precautions are therefore justified in efforts to prevent human exposure. The other is that the effects seen are not unusual or unexpected, in the light of our total understanding of radiation carcinogenesis, and that we can therefore have some confidence in our ability to understand and effectively control the transuranic exposure hazard. These are not unimportant conclusions.

One may enlarge upon the "general impressions" noted above. From the total body of animal data on transuranic element toxicity, qualitative inferences may be drawn as to the probable organs of major carcinogenic involvement. These would be lung, following inhalation of any transuranic compound; bone, following systemic distribution, including inhalation of more soluble forms; and to a probably lesser degree, liver, following systemic distribution.

Because of the heterogeneous (particulate) localization of plutonium in the lung, none of the human lung cancer experience can be applied with confidence to the prediction of plutonium effects. The complex heterogeneity of distribution also frustrates any realistic dosimetric approach. Under these circumstances, animal data must be considered the most applicable information (3). It has been argued that plutonium-induced lung tumors in animals are of a different type than those most commonly seen in humans, and that the animal is therefore a poor model for man (1). It would seem more reasonable to conclude that, since the pattern of plutonium distribution in the lung is different from that of the demonstrated lung carcinogens for man, the tumor type should be expected to differ, in man as well as in experimental animals.

Human experience with radium carcinogenicity in bone is relevant to the prediction of human plutonium risks. This is particularly true of the  $^{226}\text{Ra}$  data (4). Because of its short half life,  $^{226}\text{Ra}$  irradiates bone surfaces in a manner similar to plutonium. The applicability of the radium data is supported by many animal studies attesting to the predictable relationship between the effects of plutonium and radium (4). Based only on knowledge of the differing distributions of plutonium and radium in bone, and on assumptions regarding the critical cells at risk, one can estimate the relative carcinogenicity of plutonium and radium when compared on an average-dose-to-bone basis; this amounts to calculating, as best one can, the radiation dose to the presumed cells at risk (5). I, personally, have more confidence in the derivation of such a ratio from observed cancer production, in several animal species, with no assumptions regarding distribution or cells at risk. One may well question the quantitative applicability of such an animal ratio to man; one may wish to "correct" the ratio for known physiological differences between the animal and man; but one at least starts from a measurement of actual cancers, produced by the actual material of concern.

It is true that estimates of the carcinogenicity of the transuranics in lung and bone, whether based on animal data or on dosimetric extrapolation of observations with other radiation sources in man, are in reasonable agreement (3,4). The two approaches may therefore be considered to support each other. There are other instances, however, where the animal data do not support the dosimetric predictions.

A major fraction of systemically distributed transuranics is deposited in liver, where, except for rats and mice, it is tenaciously retained. The average radiation dose to liver in dog and man is equal to, or greater than,

the dose to bone. Malignant liver tumors are, however, much less frequently observed than bone tumors in the long-term dog studies (6,7). Whether the accumulating human experience with Thorotrast-induced liver tumors is applicable to the transuranics is uncertain, because of the relatively massive quantities of thorium involved and apparent differences in tumor type (8).

From dosimetric considerations, the localization of plutonium in bone marrow and on bone surfaces might be expected to produce leukemias. Malignancies involving the hematopoietic system have, however, been very infrequently observed in animal studies (9).

Perhaps the most critical demonstration of the absence of transuranic effect in experimental animals is that concerned with pulmonary lymph nodes. Following inhalation of insoluble plutonium, these lymph nodes accumulate and retain concentrations of plutonium that deliver radiation doses that may exceed the dose delivered to the lung by a hundred-fold, but cancers arising from these lymph nodes are rarely seen; the lung is clearly the critical organ, though it receives a much smaller radiation dose (10).

Animal toxicity data have also proved invaluable in disposing of the "hot particle" hypothesis. This contention that particulate plutonium is perhaps  $10^5$  times as toxic as uniformly distributed plutonium, because of the high dose in the immediate vicinity of the particle (11), was given little credence in more informed circles. But, though one might construct elaborate arguments against it on theoretical grounds, one could not "disprove" it. However, the many animal experiments that had employed a variety of particulate forms of plutonium, and which showed no unusual toxic effects that might be attributed to "hot particles", convincingly disposed of the hypothesis (12,13).

A still unanswered question on transuranic toxicity, to which animal experiments should provide an answer, is that of age-related sensitivity to carcinogenesis. Because of rapid bone growth in the very young, and consequent burial of surface-deposited transuranics, it might be predicted that the period of rapid growth would be one of decreased sensitivity to osteosarcoma induction. However, the presumed increased sensitivity of rapidly dividing cells, and the longer period available for subsequent cancer development, would suggest the opposite conclusion. Experiments in progress with rats (14) and dogs (7) suggest that, on an administered dose per kilogram basis, the very young animal is not more sensitive than the adult, but these are very preliminary data and much remains to be learned in this area. The effect of transuranics inhaled at an early age is only just beginning to receive attention (15).

In conclusion, let me stress that I am not arguing against a continuing effort to understand radiation carcinogenicity in terms of the basic mechanisms involved. I would argue, however, that our current understanding of these mechanisms is not a completely adequate basis, nor is it always the best basis, for the estimation of risks from many internally deposited radionuclides. To substitute theory for experiment in these areas may not only produce the wrong conclusion, but perhaps more importantly may lead to a false sense of the adequacy of our understanding. Most importantly, it will discourage the conduct of the very experiments that are vital to the improvement of this understanding.



#### REFERENCES

- (1) Advisory Committee on the Biological Effects of Ionizing Radiation, The Effects on Populations of Exposure to Low Levels of Ionizing Radiation, National Academy of Sciences - National Research Council, Washington, DC (1972).
- (2) Rosenblatt, L. S., et al., "Extrapolation of radiation-induced tumor incidence from animals to man", Biological and Environmental Effects of Low-Level Radiation, Vol. I, IAEA, Vienna (1976) 237.
- (3) BAIR, W. J., THOMAS, J. M., "Prediction of the health effects of inhaled transuranium elements from experimental animal data", Transuranium Nuclides in the Environment, IAEA, Vienna (1976) 569.
- (4) MAYS, C. W., et al., "Estimated risk to human bone from  $^{239}\text{Pu}$ ", Health Effects of Plutonium and Radium (JEE, W.S.S., Ed.) J. W. Press, Salt Lake City, Utah (1976) 343.
- (5) SPIERS, F. W., VAUGHAN, J., "Hazard of plutonium with special reference to the skeleton", Nature 259 (1976) 531.
- (6) TAYLOR, G. N., et al., "Hepatic changes induced by  $^{239}\text{Pu}$ ", Radiobiology of Plutonium (STOVER, B. J., JEE, W. S. S., Eds.) J. W. Press, Salt Lake City, Utah (1972) 105.
- (7) JEE, W. S. S., et al., "Current status of Utah long-term  $^{239}\text{Pu}$  studies", Biological and Environmental Effects of Low-Level Radiation, Vol. II, IAEA, Vienna (1976) 79.
- (8) MAYS, C. W., "Estimated risk from  $^{239}\text{Pu}$  to human bone, liver and lung", Biological and Environmental Effects of Low-Level Radiation, Vol. II, IAEA, Vienna (1976) 373.
- (9) VAUGHAN, J., "Plutonium -- a possible leukaemic risk", Health Effects of Plutonium and Radium (JEE, W. S. S., Ed.) J. W. Press, Salt Lake City, Utah (1976) 691.
- (10) BAIR, W. J., "Toxicology of plutonium", Advan. Radiat. Biol. 4 (1974) 255.
- (11) TAMPLIN, A. R., COCHRAN, T. B., Radiation Standards for Hot Particles, Natural Resources Defense Council, Washington, DC (1974).
- (12) Ad Hoc Committee on "Hot Particles", Alpha-Emitting Particles in Lungs, National Council on Radiation Protection and Measurements, Washington, DC (1975).
- (13) Ad Hoc Committee on "Hot Particles" of the Advisory Committee on the Biological Effects of Ionizing Radiation, Health Effects of Alpha-Emitting Particles in the Respiratory Tract, National Academy of Sciences -National Research Council, Washington, DC (1976).
- (14) MAHLUM, D. D., SIKOV, M. R., unpublished.
- (15) SIKOV, M. R., unpublished.

RESPIRATORY TRACT CARCINOGENESIS IN LARGE AND SMALL  
EXPERIMENTAL ANIMALS FOLLOWING DAILY INHALATION  
OF RADON DAUGHTERS AND URANIUM ORE DUST

B. O. Stuart, R. F. Palmer, R. E. Filipy, G. E. Dagle, K. E. McDonald  
Battelle, Pacific Northwest Laboratories  
Battelle Blvd., Richland, WA 99352

## 1. INTRODUCTION

Uranium ore miners of the Colorado plateau suffer more than 6 times the normal incidence of lung cancer (1), and their mortality rates due to pneumoconiosis and emphysema are 5 times greater than in the general population (2). Inhalation exposures of beagle dogs and rodents to radon daughters and uranium ore dust were undertaken to determine which of these uranium mine air contaminants, and at what levels, are responsible for the high incidences of these diseases.

## 2. BEAGLE DOG STUDIES

Dogs were raised and trained in our laboratory to accept chronic exposures to radon daughters with uranium ore dust (Group 1; 20 dogs), radon daughters with ore dust plus cigarette smoking (Group 2; 20 dogs), cigarette smoking alone (Group 3; 20 dogs), and sham-smoking (Controls: Group 4; 9 dogs). Exposures to 500 WL\* radon daughters plus 13 mg/m<sup>3</sup> uranium or (MMD 0.6-2.1  $\mu$ m,  $\sigma$  1.8-2.6) occurred 4 hrs/day, 5 days/week in lifespan studies. Cigarette smoke exposures simulated human smoking with oral inhalation and nose plus mouth exhalation. Radon daughters plus uranium ore dust were inhaled in head-only exposures with continuous radon sampling and twice daily radon daughters sampling. (3)

Minimal changes occurred in the respiratory tracts of the control dogs. Pulmonary fibrosis was prevalent in all Group 1 and Group 2 dogs (Figure 1). It was present as alveolar septal fibrosis in dogs sacrificed early in the experiment and, after longer exposures, occasionally involved the major portion of lung lobes. Pleural fibrosis, visible grossly as gray-white scars, was also severe after longer exposures. Small subpleural blood vessels were occluded by fibrosis of arterial walls and intimal hyperplasia in all dogs of these two groups with exposure histories >40 mo.

Pulmonary emphysema was present in all dogs from Groups 1 and 2. It ranged from slight vesicular emphysema in dogs sacrificed early to bullous emphysema in dogs with longer exposures (Figure 1). Subpleural cavities, occasionally exceeding 1 cm in diameter, were present in the lungs of 11 of 20 dogs from Group 1 and 12 of 20 dogs from Group 2, appearing several months earlier in dogs that received daily exposure to cigarette smoke in addition to radon daughters plus ore dust.

The lungs of dogs in Groups 1 and 2 that had exposure histories of >40 months showed a variety of epithelial proliferative changes, including large areas of adenomatosis, frequently progressing to squamous metaplasia of the alveolar epithelium with atypical cells (i.e., marginated nuclear chromatin, irregularly shaped nuclei, and decreased nuclear-to-cytoplasmic ratio). At >50 months of exposure to radon daughters and

\*Working Level:  $1.3 \times 10^5$  Mev of potential alpha energy from radon daughters per liter of air. WLM  $\equiv$  Working Level Month; 170 hours in an atmosphere of 1 Working Level.

uranium ore dust, lungs from 50% of Group 1 and Group 2 dogs contained large cavities within the parenchyma, surrounded by bands of hyperplastic adenomatous epithelial cells. In two of the dogs exposed to radon daughters with ore dust for 48 and 54 mo, there were epidermoid carcinomas associated with these cavities (Figure 2). The tumors were solitary masses in peripheral areas of single lobes, consisting of irregularly shaped lobules of nonkeratinizing stratified squamous epithelium, and were locally invasive into adjacent alveoli. Another epidermoid carcinoma appeared in a dog exposed to radon daughters plus uranium ore dust for 54 mo, consisting of a well-circumscribed mass composed of anaplastic cells and numerous mitotic figures (Figure 3). Three other primary lung tumors, bronchiolo-alveolar carcinomas, were present in three dogs of Group 1 exposed for 51, 54, and 54 mo. The tumors were solitary masses associated with distal bronchioles, and were locally invasive into adjacent alveoli. A bronchiolo-alveolar adenoma, composed of a papillary proliferation of epithelium, was found in a dog that also had epidermoid carcinoma. A fibrosarcoma was present in the right apical lobe of the lung from another Group 1 dog exposed for 54 mo. A bronchiolo-alveolar carcinoma was present in a Group 2 dog exposed for 52 mo. Two dogs of Group 1 and one dog of Group 2 had squamous carcinomas with apparent origins in the nasal mucosa. A progression of changes in this time from metaplasia to neoplasia was demonstrated with increased exposure times. Total radon daughter exposure histories associated with these nine lung tumors and three nasal tumors were 10,200 to 13,400 WLM.

### 3. RODENT STUDIES

In preliminary studies in this laboratory, SPF Wistar rats received whole-body inhalation exposures to 6000-7500 WL of radon daughters with 18 mg/m<sup>3</sup> uranium ore dust for 90 hrs/week (4). Radon, radon daughters and uranium ore dust measurements were performed as in the beagle dog studies. The first of 16 animals died at 52 days after the beginning exposures, having accumulated 9400 WLM of radon daughter exposure. Mortality reached 50% at 110 days, with a total of 29,400 WLM. Histopathologic examination revealed radiation pneumonitis, septal fibrosis, alveolar lining cells sloughed into alveolar lumina, and macrophage proliferation. Atypical nuclei of alveolar septal cells were apparent. Bronchiolar epithelial hyperplasia and squamous metaplasia of nasal epithelium were common in these rats. Severe suppurative laryngitis, bronchitis, and tracheitis were frequent and may have been important contributing factors in the deaths of these animals. No malignant tumors were found, perhaps due to abbreviated survival times.

In a subsequent study, the same species of rat received inhalation exposures to 5400-7400 WL of radon daughters with 17 mg/m<sup>3</sup> of uranium ore dust for 6 hrs/day, 5 days/week. The first animal died at 80 days after beginning exposures. Mortality reached 50% at 156 days, with total radon daughter exposure of 23,000 WLM. Several rats showed extreme squamous metaplasia of pulmonary alveolar epithelium with keratin pearls, but without evidence of vascular invasion. These lesions were classified as preneoplastic. One of the 16 rats had a pulmonary squamous carcinoma with evidence of vascular invasion at a total exposure of 24,500 WLM. Squamous metaplasia of nasal and turbinate epithelium occurred, and rhinitis was also present. Squamous metaplasia was moderate to severe in laryngeal, tracheal, and bronchiolar epithelium. Other pulmonary changes included radiation pneumonitis and emphysema.

In recent studies, groups of 32 rats received inhalation exposures for periods of 84 hr per week to aerosols consisting of 900 WL of radon daughters with 15 mg/m<sup>3</sup> uranium ore dust or to laboratory air (controls). Exposures were continued for 150 days, and both groups were subsequently held for lifespan observation. Mortality patterns of rats exposed to radon daughters with ore dust showed 50% survival at 460 days vs 670 days for controls. The exposed animals showed slight to moderate nasal epithelial squamous metaplasia in 25 out of 32 cases. Nineteen of the exposed rats developed frank carcinoma of the lungs, including 17 cases of squamous carcinoma, one adenocarcinoma and one animal that showed both squamous and adenocarcinomas (Figure 4). The majority of these malignant neoplasms appeared after 9 months following the cessation of exposures. Their total radon daughter exposure, received over 5 months, was 9200 WLM.

#### 4. DISCUSSION

The findings of pulmonary fibrosis related to pneumoconiosis and severe pulmonary emphysema in dogs that received daily exposures to radon daughters plus uranium ore demonstrates an appropriate large animal model for the study of these fatal pulmonary diseases in uranium miners. The appearance of these lesions in dogs with chronic exposures including uranium ore dust at levels that have been recorded in operating mines, i.e., up to 15 to 20 mg/m<sup>3</sup> (5) demonstrates that such airborne dust represents a severe inhalation hazard to uranium miners.

Recent studies of pulmonary carcinogenesis in rats by Chameaud et al. (6) showed similar incidences of epidermoid carcinoma after 9500 WLM of radon daughter inhalation without ore dust. However, recent studies in our laboratory of radon daughters without ore dust show greater nasopharyngeal hyperplasia, but only 3 to 6 percent frank squamous carcinoma compared to 60% incidence for radon daughters in conjunction with uranium ore dust. Studies at another laboratory (7) showed minimal changes in 50 dogs that received 200 to 10,000 WLM of radon daughter exposure without uranium ore dust. Our dog study, however, showed high incidences of massive pulmonary fibrosis, emphysema, and 25% incidence of respiratory tract squamous carcinoma at exposure of 10,000 to 13,000 WLM radon daughters with uranium ore dust. Two conclusions may be possible:

- 1) The presence of the ore dust provides physical or physiological interaction that markedly potentiates carcinogenesis or other pathogenesis.
- 2) There exists a dose-rate effect, possibly dependent on normal or stimulated recovery mechanisms.

Both possibilities would cast doubt upon the adequacy of the total or cumulative Working Level Month concept as a sufficient monitor of carcinogenic or other lethal pulmonary disease risk.

Further studies are planned to determine the contributory or pathogenic role of uranium ore aerosols by evaluation of chronic exposure to this material alone, or to minimal concentrations of ore aerosols with attached radon daughters. A possible dose-rate effect in carcinogenesis is suggested by the appearance of 25% incidence of pulmonary neoplasms in dogs receiving radon daughters with ore dust inhalation exposures over several years in our studies vs no tumors (7) from equivalent total doses of radon daughters received in a few months. Comparison of the results of our first and second rat studies shows that reduction of the rate of exposure (90+30 hrs/week) allows a protraction of the exposure period and the appearance of carcinoma, suggesting a dose-rate effect. Comparison of the first and second with the third rat study shows greatly increased incidence of pulmonary carcinoma (<10%-60%) from inhaled radon daughters with ore dust when the dose-rate and total dose were reduced by lowering the radon daughter concentration 7-fold (6300 WL vs 900 WL). Additional studies are planned to determine the relative carcinogenic risks at different dose rates.



Fig. 1. Pulmonary fibrosis and bullous emphysema in the lungs of a dog exposed for 54 mo to radon daughters and uranium ore dust; 12X.



Fig. 2. Epidermoid carcinoma associated with a cavity in the lungs of a dog exposed for 48 mo to radon daughters and uranium ore dust; 6X.

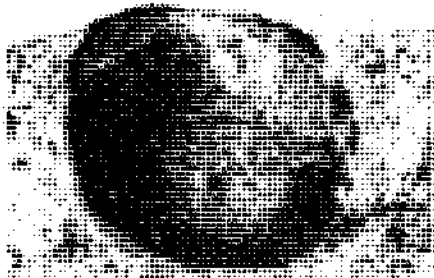

Fig. 3. Epidermoid carcinoma in the lungs of a dog exposed for 54 mo to radon daughters and uranium ore dust; 9X.



Fig. 4. Squamous carcinoma plus adenocarcinoma in the lungs of a rat exposed for 5 mo to radon daughters and uranium ore dust; 100X.

#### REFERENCES

- (1) ARCHER, V.E., WAGONER, J.K., LUNDIN, F.E. "Lung cancer among uranium miners in the United States", Health Physics 25 4 (1973) 351
- (2) ARCHER, V.E., GILLAM, J.D., WAGONER, J.K., "Respiratory disease mortality among uranium miners", p 280 in Occupational Carcinogenesis (SAFIOTTI, U., WAGONER, J.K., Eds) Annals of the NY Academy of Sciences, New York (1976)
- (3) STUART, B.O., WILLARD, D.H., HOWARD, E.B. "Uranium mine air contaminants in dogs and hamsters", pp. 413-427 in Inhalation Carcinogenesis (HANNA, M.G., NETTESHEIM, P., GILBERT, J.R., Eds.), USAEC; CONF-691001 Oak Ridge, Tennessee (1970)
- (4) PALMER, R.F., STUART, B.O., FILIPY, R.E. "Biological effects of daily inhalation of radon and its short-lived daughters in experimental animals", pp. 507-519 in Noble Gases (STANLEY, R.E., MOGHISSI, A.A., Eds.) USEPA, CONF-730915 Washington, D.C. (1973)
- (5) GEORGE, A.C., et al. "Investigation of atmospheric constituents in a small uranium mine", U.S. Health and Safety Lab. Technical Memorandum 71-2, New York (1971)
- (6) CHAMEAUD, J., PERRAUD, R., LaFUMA, J., MASSE, R., PRADEL, J. "Lesions and lung cancers induced in rats by inhaled radon 222 at various equilibriums with radon daughters", pp. 411-421 in Experimental Lung Cancer (KARBE, E., PARK, J.F., Eds.) Springer-Verlag, New York (1974)
- (7) MORKEN, D.A. "The biological effects of radon on the lung", pp. 501-506 in Noble Gases (STANLEY, R.E., MOGHISSI, A.A., Eds.) USEPA, CONF-730915, Washington, D.C. (1973)

OSTEOGENIC SARCOMAS IN MICE AFTER SINGLE OR REPEATED ADMINISTRATIONS OF  
Ra-224 AS RELATED TO FINDINGS IN Ra-226 BURDENED ANIMALS

Dvořák, V.<sup>x)</sup>, Klener, V.<sup>x)</sup>, Malátová, I.<sup>x)</sup>, Sedlák, A.<sup>x)</sup>, Thomas, J.<sup>x)</sup>,  
Bubeníková, D.<sup>x)</sup>, and Kofránek, V.<sup>x)</sup>

<sup>x)</sup> Medical Faculty of Hygiene, Charles University, Praha.

<sup>x)</sup> Department of Radiation Hygiene, Institute of Hygiene and Epidemiology,  
Praha

## 1. INTRODUCTION

A long-term program concerned with the time and space distribution of the skeletal dose following the administration of the radium isotopes in relation to delayed effects has been carried out for several years. The aim of the Ra-224 incidence studies was to achieve by multiple administrations of the isotope the required time course of the mean skeletal dose from Ra-224 and its daughter products, i.e. the course simulating the time distribution of the mean skeletal dose resulting from a single injection of Ra-226 as a basis of relative toxicity evaluation. As recently reported (1,2), comparable mean skeletal doses were achieved for some levels of exposure in an experiment with 150 times repeated administrations of Ra-224, and data for a more realistic administration schema were obtained. Additionally, an experiment was carried out to determine the possible role of the Ra-224 solution contaminant - Th-228 - in the osteogenic sarcomas induction.

Recently, a separate experiment was carried out, in which single injections of Ra-224 were given which corresponded to the summary activities injected in the experiment with repeated Ra-224 administrations, groups of mice with Ra-226 body burdens serving again as reference.

The experimental set-up of the experiments is schematically given in Tables 1, 2 and 3. This communication is confined to the evaluation of the osteogenic sarcoma yields.

## 2. METHODS AND RESULTS

Ten weeks old SPF female mice of Czechoslovak production, strain ICR (Swiss), were used. Radium isotopes in ionic form were injected intraperitoneally in 0.1 ml volumes of solution, pH 3-4, with  $\text{CaCl}_2$  as a carrier.

Radium-224 was obtained from Th-228 (Amersham Laboratories) in a generator-type device. Radium-226 was of Soviet provenience. All groups of mice were kept under standard conditions and observed until extinction.

Osteogenic sarcoma diagnosis was based on histological verification of X-ray findings. Among 550 non-active animals from the experiments reported, one osteogenic sarcoma was found.

Skeleton dose calculation was based on retention data obtained in a series of single-administration experiments (3), considerable attention being paid to the kinetics of Ra-220 and other Ra-224 daughter products.

The experimental setting with the repeated administrations of Ra-224 is given in Table 1.

N Mice with o.s.	N o.s.	Dose (Gy)	kBq per mouse	Levels		kBq <sup>x)</sup> per mouse	Dose <sup>xx)</sup> (Gy)	N <sup>xxx)</sup> o.s.	N mice with o.s.
				226 Re	224 Ra				
7	7	120	71.7	UF					
40	52	55	25.1	UE	TC	191.5	24	56	43
18	19	24	8.9	UD	TB	69.5	8.5	80	51
					TA	23.9	3.6	23	21

x) Activities given in 150 fractions according to the administration scheme mentioned in the Introduction.

xx) Doses achieved at an interval of 140 days before death of the mice with osteogenic sarcomas.

xxx) o.s. - osteogenic sarcomas

Note: N = 100 in all groups; controls - 200 mice, 200 animals received a non-active solution.

TABLE 1

Table 2 presents the basic data concerning the experiment with single injections of Ra-224 and Ra-226.

N Mice with o.s.	N o.s.	Dose (Gy)	kBq per mouse	Levels		kBq per mouse	Dose (Gy)	N o.s.	N mice with o.s.
				226 Ra	224 Ra				
17	18	16	6.1	UD'	TB'	65.4	14.3	7	7
4	4	5.7	1.8	UC'	TA'	21.2	4.6	4	4

Note: N = 100 in all groups; controls - N = 100.

Abbreviations see in Table 1.

TABLE 2

In the additional experiment, Th-228 (Amersham provenience) as nitrate, Th-232 serving as a carrier, was administered repeatedly in four week intervals, the amount given corresponding to the activities of the Th-228, contaminating the injection solution, as determined in the relevant 4-week periods of the experiment with the repeatedly administered Ra-224; a total of 17 injections was administered (Table 3).

$^{224}\text{Ra}$ 1)	$^{228}\text{Th}$	N	Bq/mouse	O.S. %
(TE) .....	E	50	566.1	18
(TD)				
TC .....	C	75	66.6	4
TH .....	B	100	26.6	-

1) see Table 1

Note: controls - N = 50

TABLE 3

### 3. DISCUSSION AND CONCLUSIONS

The additional experiment with Th-228 permitted to determine that in our experimental setting the contribution to the skeletal dose from this contaminant did not exceed 5% of the dose resulting from the injections of Ra-224 and its daughter products. It can further be stated that the levels of interest being considered, osteogenic sarcomas were observed only on the level of the administered Th-228, corresponding with the highest level of Ra-224 repeatedly administered, in the area of 100 rad mean skeletal dose, i.e. 3 in 75 mice. All three were evidenced between 75 to 97 weeks beginning from the first administration, that is in a period in which already the last of the mice from the relevant TC radium group had died.

The determined incidence of osteogenic sarcomas in groups with single injections of Ra-224 when compared with the results of the Neuberger laboratory (4) on the basis of the activities given, having in mind the different methods of evaluation of skeletal dose and the different age of the animals, is not contradicting for the range of activities used.

Concerning the toxicity of Ra-226, in view of the comparability of some parameters employed (age of the mice, weight of skeleton), the data of Mays were considered and, as an illustration, we have evaluated our data with the same method as this author (5), see Fig. 1. The figure shows that the data for Ra-226 toxicity from both laboratories are in good agreement.

Our own data permit by direct comparison of the incidence of osteogenic sarcomas in groups with a comparable mean skeletal dose (levels TE and TC versus UD) to determine a 3 to 4fold higher effectiveness of repeated Ra-224 administrations in comparison with Ra-226 single injection in terms of relative toxicity in the given range of doses. If only the percentage of mice with osteogenic sarcomas is considered the values of toxicity would be, in view of the numerous multifocal findings only in groups given repeated injections of Ra-224, accordingly lower. When considering the results of single administrations and repeated long-term injections the data show consistency.



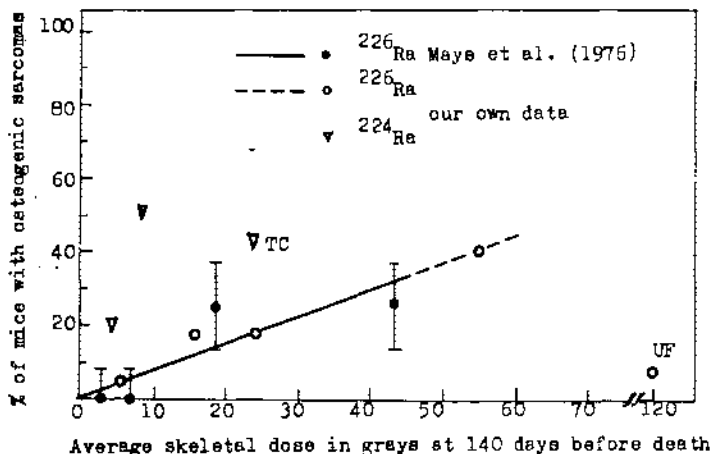

FIGURE 1

REFERENCES

- (1) DVORÁK, V. et al., Osteogenic sarcomas in mice after Ra-224 or Ra-226 administrations, 2nd Internat. Symp. Biological Effects of Ra-224, München-Neuherberg, Sept. 20-21, (1976). Proc. in press.
- (2) KOFRÁNEK, V. et al., Biological effects of Ra-224 and Ra-226 and their relative radiotoxicity in mice, *ibid.*
- (3) THOMAS, J., MALÁTOVÁ, I., Imitation of the time course of the dose in mouse skeleton after single Ra-226 administration by repeated Ra-224 administrations, Proc. of 4th Conf. on Radiation Hygiene, Jasná, Postgr. Inst. Press, Hradec Králové (1971), 353.
- (4) HUG, O. et al., Production of osteosarcomas in mice and rats by incorporation of radium-224, in Radiation-Induced Cancer, IAEA, Vienna, (1969), 393.
- (5) MAYS, C.W. et al., Estimated risk to human bone from Pu-239, Health Effects of Plutonium and Radium (JEE, W.S.S., Ed.), J.W. Press, University of Utah, Salt Lake City, (1976), 343.

CANCERS PULMONAIRES INDUITS CHEZ LE RAT PAR IRRADIATION INTERNE  $\alpha$  ;  
CELLULES CIBLES ET CELLULES SENSIBLES

P. FRITSCH, R. MASSE, D. NOÛBE, H. METIVIER, M. MORIN, J. LAFUMA  
R. PERRAUD, J. CHAMEAUD

C.E.A. - DPr/SPTe - BP 6 - 92260 FONTENAY AUX ROSES  
\*COGEMA - Service Médical - 87640 RAZES

-----

Si la fréquence d'apparition des tumeurs pulmonaires apparaît particulièrement révélatrice de la relation dose-effet (1) ce paramètre ne peut être seul considéré comme représentatif du dommage causé par l'irradiation  $\alpha$  du poumon. En ne retenant que la fréquence tumorale on sous entend le résultat d'un phénomène aléatoire comme facteur exclusif. Or, pour une même dose, la médiane de survie des animaux n'apparaît pas diminuée chez les porteurs de tumeurs par rapport aux animaux qui n'en ont pas (2).

De ce fait il apparaît nécessaire de définir clairement la nature de ces tumeurs par rapport aux tumeurs humaines, de préciser les relations entre cellules renouvelées et irradiées et cellules considérées comme "cibles" de rechercher les composants cellulaires et tissulaires radiosensibles non directement impliqués dans la genèse tumorale elle même, mais étroitement associés au tissu dans lequel la tumeur prend naissance.

MATERIEL ET METHODES

1) Analyses histopathologiques

401 tumeurs du poumon ont été analysées selon les techniques histologiques usuelles. L'ultrastructure de 36 de ces tumeurs a été observée, 20 tumeurs ont été greffées chez la souris nude ; 5 tumeurs ont pu être cultivées in-vitro. Deux lignées, un carcinome bronchoalvéolaire et un angiosarcome sont établies chez le rat Wistar isogénique et régulièrement létales.

2) Analyses morphométriques

L'évaluation des cellules totales du poumon est obtenue après mesure absolue du nombre de macrophages alvéolaires pour les techniques de lavage pulmonaire (3). La répartition des cellules est ensuite déterminée par comptage du pourcentage relatif des noyaux cellulaires appartenant aux différentes lignées, après identification au microscope électronique (4). L'évaluation des cellules en phase S est obtenue par injection de thymidine tritiée.

RESULTATS

La fréquence des tumeurs observées apparaît dans le tableau I. Les 20 tumeurs greffées se sont révélées fertiles chez la nude. 7 d'entre elles ont pu être transplantées successivement sans perte de la malignité représentant tous les types étudiés. Du point de vue histopathologique, ces tumeurs sont de types très variables. Parmi les tumeurs épithéliales le groupe le plus homogène est constitué par les carcinomes bronchioalvéolaires et les carcinomes alvéolaires. A l'exception de la variété compacte, dont l'ultrastructure révèle qu'il s'agit d'une tumeur composée uniquement de pneumocytes II plus ou moins altérés, ces tumeurs sont typées par l'aspect papillo-végétant qui est aussi bien caractéristique chez l'homme. Comme chez l'homme deux variétés peuvent être distinguées (5) l'une sécrétant une sérosité PAS positive et composée de cellules proches des cellules séreuses bronchiques (6),

l'autre composé pour la plupart de cellules indifférenciées, ou comparable soit aux pneumocytes II; soit aux cellules de Clara; jamais dans ces tumeurs ne se remarquent de cellules évoquant les cellules basales, ni de cellules à caractère épidermoïde fût il très indifférencié. Les jonctions sont du type "zona occludens".

Les carcinomes épidermoïdes sont plus ou moins différenciés, et constitués soit des cellules de type épidermique, soit des cellules proches des cellules basales des bronches souches. De ces tumeurs se rapproche immédiatement la variété rare de type adénoacanthome, tumeur de caractéristique tubulaire pluristratifiée comportant une assise de cellules identiques aux cellules basales et une couche luminale à microvillosités trappues riches en cell-coat donnant au microscope optique l'aspect d'une bordure en brosse. Le réticulum endoplasmique est peu développé, les jonctions cellulaires sont des desmosomes. L'exagération du caractère sécrétoire, la disparition de l'assise basale, conduisent à l'adéno carcinome bronchogénique. Le type est tubulo acinaire, aspect tumoral fréquemment associé aux carcinomes épidermoïdes différenciés pour donner la variété composite. Toutes les étapes de transition existent dans la même tumeur entre l'aspect ultrastructural du carcinome épidermoïde différencié, indifférencié, et les variétés "anaplasiques" à grandes cellules à cellules géantes et à cellules polygonales. Dans la tumeur compacte macro épidermoïde analysée en ultrastructure des cellules à caractère évident de cellules basales sont présentes parmi les cellules à mucus.

L'ensemble de ces caractéristiques justifie que les tumeurs épithéliales soient regroupées en deux types simples : carcinomes bronchogéniques d'une part, carcinomes bronchioalvéolaires de l'autre. Quand ces tumeurs gagnent le médiastin leur aspect est quelque peu modifié par la prolifération mésothéliale et l'apparition d'une composante fibroblastique fréquemment tumorale. Un fibrosarcome typique a été obtenu à partir de culture d'un bronchioalvéolaire suivie de greffe.

Les mésothéliomes sont rares et d'interprétation difficile, les deux tumeurs retenues étaient exclusivement pleurales et gagnaient la cavité péritonéale. Les angiosarcomes sont beaucoup plus fréquents, tous à l'exception d'un ont été observés à forte dose délivrée de manière hétérogène. Leur ultrastructure est très simple et caractéristique des cellules endothéliales peu différenciées. Les réticulosarcomes pulmonaires sont d'apparition tardive ils ont été pour la plupart observés après de faibles doses 100 - 1000 rads. Du point de vue de l'ultrastructure deux types cellulaires constitutifs coexistent, l'un caractérisé par des cellules riches en réticulum lisse, l'autre par des cellules à aspect T blastique.

La malignité des tumeurs décrites ne peut faire de doute malgré un très faible taux de métastases extrapulmonaires. Les cultures et les greffes en montrent nettement les caractéristiques.

De cette analyse ressortent nettement les cellules originelles : une cellule d'origine bronchique observée constamment dans la bronche métaplasique donne naissance à la variété bronchogénique ; la cellule bronchiolaire indifférenciée et sans doute le pneumocyte II alvéolaire et bronchiolaire sont à l'origine de la variété bronchioalvéolaire, les cellules endothéliales, les fibroblastes et le tissu lympho réticulaire constituant les autres cellules cibles du parenchyme. Les cellules de Kultchisky, origine probable des carcinomes oat cells humains ne sont pas représentées dans cette série.

#### Cellularité pulmonaire

Dans le cas du rat de 250g sans traitement, le nombre total de cellules ap-

paraît dans le tableau 2. Les cellules bronchiques et bronchiolaires représentent 20 à 25% des cellules épithéliales totales chez le rat. L'indice de marquage moyen de ces cellules est faible voisin de 0,5% cependant il existe des foyers irrégulièrement répartis où la prolifération est très rapide atteignant 25 à 50% des cellules. Quantitativement ce phénomène n'affecte pas l'équilibre global du pool. Il peut néanmoins avoir une signification importante pour la localisation des tumeurs. Il permet notamment, par phénomène de bronchiolisation (7), le glissement de cellules bronchiques dans les alvéoles ce qui explique le caractère apparemment distal des néoplasmes bronchogéniques. Les cellules de Kultchisky représentent moins de 50.000 cellules. Les modifications de la cellularité après irradiation : PuO<sub>2</sub> 2500 rads, Radon 6000 WLM en 3 mois apparaissent dans le tableau 3.

L'une des caractéristiques les plus étonnantes est la constance des rapports des populations malgré l'influence de l'âge de l'irradiation. Elle témoigne d'une stricte régulation. Dans les conditions choisies (animaux non infectés non porteurs de tumeurs) la cellularité bronchique demeure également stable. Il n'existe que de très minimes variations individuelles. Sont significatives les différences portant sur la diminution du rapport pneumocytes II/pneumocytes I, l'augmentation des macrophages chez les irradiés, l'augmentation des cellules septales inflammatoires : mastocytes, plasmocytes polynucléaires, histiocytes. Chez les animaux soumis au Radon, l'augmentation de monocytes est également significative. Chez les animaux âgés le rapport pneumocyte II/pneumocyte I diminue également significativement, les lymphocytes diminuent et les cellules septales augmentent.

Les tissus de 3 animaux irradiés par PuO<sub>2</sub> ont donné naissance à des proliférations bronchioloalvéolaires après greffe chez la souris Nude (8), aucun des témoins n'a donné ce type de prolifération, les tissus des trois animaux témoins Radon un an ont été très rapidement remaniés par la sclérose sans prolifération après greffe chez la nude.

## DISCUSSION

Aucune caractéristique de la cellularité pulmonaire ne permet de prévoir la fréquence des tumeurs observées chez le rat. Le type de cellules intermittentes dominant est endothélial ; le type tumoral dérivé ne représente que 3,2% des tumeurs totales. Le pool total des cellules bronchiques engagées dans le cycle est lui-même faible, il s'oppose nettement par exemple au pool des cellules de l'oesophage en continu renouvellement et qui n'a donné naissance à aucune tumeur dans cette expérimentation. De nombreux foyers d'adénomatose précèdent l'apparition des tumeurs. Ces lésions n'ont cependant jamais proliféré après greffe chez la souris nude. Ce résultat s'oppose à la fréquence des proliférations observées lors de la greffe de parenchyme irradié histologiquement normal (8).

Le tissu pulmonaire est donc capable de maintenir son homéostasie malgré une irradiation sévère tout en acquérant progressivement le caractère pré-tumoral. Malgré les faibles variations numériques, les lignées même très différenciées comme les macrophages alvéolaires sont très radiosensibles (9) cette sensibilité apparaît lors de la dernière mitose de différenciation (10). Il est donc possible de concevoir que les cellules cibles pour la cancérogénèse sont également des cellules senescentes accidentellement conduites à la prolifération. Le pool de cellules marginées dans les capillaires pulmonaires représente 30% des lymphocytes circulants et 200% des monocytes circulants, il est vraisemblable qu'intervient une action directe de l'irradiation sur ces cellules qui assurent la surveillance immunitaire. L'homéostasie de cette population montre que le phénomène de margination se fait aux dépens de l'économie immunitaire générale. Aucune variation n'est notable dans la lignée fibroblastique,

cependant des modifications temporaires du métabolisme du conjonctif ont été observées en phase de latence pré-tumorale (11). Ce phénomène ne coïncide pas étroitement avec la cancérisation sur cicatrice et indique qu'une altération générale du rapport épithélium conjonctif doit être recherchée.

### R E F E R E N C E S

- (1) BAIR W.J., THOMAS J.M., "Transuranium Nuclides in the Environment", (1976) 569 (IAEA-SM-199/58).
- (2) LAFUMA J., NENOT J.C., MORIN M., MASSE R., METIVIER R., NOLIBE D., SKUPINSKI W., "Experimental Lung Cancer", KARBE E., PARK J.F. Ed. Vol I, Springer Verlag New York (1974) 443.
- (3) SEDAGHAT B., MASSE R., NENOT J.C., LAFUMA J., MARTIN J.C., C.R. Acad. Sci., Série D, Paris 273 (1971) 229.
- (4) FRITSCH P., MASSE R., LÉBAS F., LAFUMA J., CHRETIEN J., C.R. Acad. Sci. Série D, Paris 281 (1975) 1105.
- (5) GREENBERG S.D., SMITH M.N., SPJUT H.J., J. Clin. Path., 63 (1975) 153.
- (6) JEFFERY P.K., REID L., J. Anat. 120 (1975) 295.
- (7) NETTESHEIM P., Lab. Invest. 26 (1972) 210.
- (8) NOLIBE D., MASSE R., FRITSCH P., LAFUMA J., "Biological and Environmental Effects of Low Level Radiation". Vol II (1976) 95 (IAEA-SM-202/403).
- (9) MASSE R., "Inhaled Particles III" W.H. WALTON Ed. Vol I, Unwin Brothers Limited, (1971) 247.
- (10) MASSE R., FRITSCH P., NOLIBE D., LAFUMA J., CHRETIEN J., "Pulmonary macrophage and epithelial cells" Sixteenth Annual Hanford Biology Symposium. Richland U.S.A. 27-29 Sept. (1976) (sous presse).
- (11) MÉTIVIER H., MASSE R., NOLIBE D., LAFUMA J., Symposium Inhaled Particles and Vapours IV - Edinbourg 22-26 Sept. (1975) Pergamon Press Oxford (sous presse).

Tableau 1 : Cellularité du poumon excisé en pourcentage relatif (1000 cellules examinées en moyenne).

	TENDONS		TENDONS		RABON		RABON	
	3 MOIS N = 7	1 AN N = 5	18 MOIS N = 2	1 AN N = 3	1 AN N = 2	18 MOIS N = 3	18 MOIS N = 3	
ENDO.	39,3	39,0	40,3	37,2	37,6	38,6		
FIBRO.	22,3	20,2	21,2	21,0	19,4	20,8		
P1	7,8	9	9,9	11,3	9,9	8,3		
P11	10,7	11,7	10,9	11,3	7	9,7		
MAC.	2	2	1,8	2,6	3,2	4,8		
MONO.	5	6,6	5,7	5,2	7,8	7,3		
LYMPHO.	9,2	7,4	6,6	8,3	7,9	6,2		
POLY.	2,6	2,2	3,1	2,8	2,8	4,1		
SEPTALES ADA INCLUES	1	1,6	2,5	2,7	4	5		

Tableau 2 : Cellularité du parenchyme pleurique pour 23,4 x 10<sup>6</sup> macrophages.

TYPE	ENDO.	FIBRO.	P.1.	P.11	MAC.	CIRCULANTS
N/10 <sup>6</sup>	44,1	25,8	49,1	122,3	22,6	292
d	7,4	20,6	11,2	14,0	4,8	14,8
Indice de peroxydase %	3	0,35	0	1,7	2,5	1

Tableau 3 : Types histologiques des lésions pulmonaires analysées.

TYPE	AMBI	MICROSCOPE ELECTRONIQUE	SANTE
SPERMATOPHYTES	147		
avec différenciation sans différenciation	101 46	9 1	6
ADENOCARCINOMES GLANDULAIRES	17		
TUMEURS CARCINOMES	17	4	
ADENOCARCINOMES A CELLULES IMMATURES	3	1	
ADENOCARCINOMES A CELLULES IMMATURES	1	1	
TUMEURS NON-EPITHELIALES	2	1	
ADENOCARCINOMES	2	1	
ADENOCARCINOMES GLANDULAIRES IMMATURES	100		7
à cellules sèches à cellules humides	38 134	8 12	
CARCINOMES ALVEOLAIRES COMPACTS	10	1	
ADENOCARCINOMES	13	8	2
ADENOCARCINOMES	8		
ADENOCARCINOMES	1	1	1
ADENOCARCINOMES	18	8	2
	461	38	20

## TRAINING IN RADIOLOGICAL PROTECTION IN THE UNITED KINGDOM

E.J. Bennellick and L.D.G. Richings  
National Radiological Protection Board  
Harwell, Didcot, Oxon, England

## 1. INTRODUCTION

The emergence of a nuclear industry in the United Kingdom dates from the year 1945. For the first few years, effort was concentrated almost entirely on military requirements but with the potentialities of nuclear energy for non-military purposes becoming increasingly apparent, the emphasis of development soon switched to the field of civil application, leading by 1956 to the opening of the world's first commercial-scale nuclear power station at Calder Hall.

A virtually self-sufficient nuclear industry is now established, with substantial international trading. It includes uranium refining, fuel element manufacture and marketing, uranium enrichment, fuel element reprocessing, radioisotope production and marketing, reactor research, development and manufacture, and nuclear weapons research. Presently (1976), about thirteen percent of the total electricity generated in Great Britain is from nuclear sources. Industrial premises using radiation sources are numbered in thousands. A great increase in the use of ionising radiations has occurred in research and educational organisations, not only in universities and institutes (some of which operate nuclear reactors) but also in technical colleges and schools where the controlled use of radioactive materials is routine. There has been an enormous expansion in the way radioactivity has been applied to medicine, in research, diagnosis and treatment, and the use of machines has also increased.

As the development has taken place, so has an increased awareness of the potential detriment. This has promoted the discipline of radiological protection.

## 2. PERSONS REQUIRING TRAINING AND THE PRINCIPAL ORGANISATIONS AND DEPARTMENTS

The United Kingdom has wide ranging groups of people requiring training in radiological protection. The principal ones include full and part-time experts in radiological protection; persons employed in places which use radioactive sources in the pursuit of professional, industrial, educational or research activities; officials with regulatory functions in radiological protection; members of special services both civil and military; and persons requiring background training because of their general responsibilities. The principal organisations and bodies concerned include the nuclear energy industry, general industry, educational and research establishments, hospitals and the practitioners of medicine and dentistry, veterinary surgeons, government departments exercising specific regulatory functions, local authorities, services such as police and fire, and the armed forces and associated bodies such as HM Dockyards servicing nuclear powered submarines.

## 3. PHILOSOPHY UNDERLYING THE DEVELOPMENT OF UK TRAINING STANDARDS

Almost from the outset of the expansion of the nuclear industry, formal training courses have been a feature of the UK scene, and in the early years they were the only "open" courses in Europe. However, in keeping with national philosophy in analagous matters, the United Kingdom did not adopt legally or formally defined qualifications or standards of training

in radiological protection. Training courses developed in range and scope pari passu with the growth of the industry. Even when the stage of expansion was reached which called for specific legislation and national codes of practice in radiological safety, the policy of not adopting rigid and precise definitions was continued. Therefore, present day UK legislation and codes tend to describe responsibilities, functions and duties of people and to specify training requirements in general terms. Responsibility for health and safety is placed firmly on management and the individual operator; they have to comply with some specific requirements of the authorities who also give them some generalised guidance. To quote from legislation and codes respectively:

The employer shall ensure provision "of such information, instruction, training and supervision as is necessary to ensure, as far as is reasonably practicable, the health and safety at work of his employees"... "No person employed shall be exposed to ionising radiations unless he has received appropriate instruction (to the extent that it is necessary having regard to the circumstances of his employment) concerning the hazards involved and the precautions to be observed".

Radiological safety officers "must be chosen with regard to their technical qualifications and experience and to their general health and the suitability of their personality"... "appropriate training in radiological health and safety must be arranged for RSOs unless the Controlling Authority is satisfied that they already have the necessary knowledge and experience".

Consequently, although the training organisations define the scope and standard of the courses they provide, it remains the responsibility of management to ensure to its own satisfaction and, as necessary, to the satisfaction of the appropriate government department or other controlling authority, that its specialist employees are trained for the duties they carry out. The advantage of this approach is that it allows for qualifications and training standards to evolve in relation to actual requirements as they develop.

The National Radiological Protection Board was created by Act of Parliament in 1970, the government's purpose being to establish a national point of authoritative reference in radiological protection. The Board was given a special responsibility in training. The Board's staff are now participating in the active consideration that is currently being given to the degree of formalisation of qualifications and associated training standards necessary as a consequence of the United Kingdom's membership of the European Communities as well as new national safety legislation.

#### L. COURSES AVAILABLE IN THE UNITED KINGDOM

Training in radiological protection is included as necessary in the curriculum of normal scientific, technical and medical courses. Training is generally also given at the place of employment, either formally or "on the job" or as a combination of both. There are specific training courses available throughout the United Kingdom at various educational and other establishments. The courses vary in duration from a day to a year, can be whole-time or part-time, comprehensive and wide-ranging or devoted to special aspects and categories. Some of the courses end in examinations which attract recognised certificates and degrees; these include, for example, at one end of the scale a part-time course sponsored by the City

and Guilds of London Institute\* for basic (non-professional) grades of radiological protection staff and at the other one-year whole time university courses leading to an appropriate MSc degree. Technical colleges figure prominently in the provision of training courses at various levels. The United Kingdom Atomic Energy Authority, National Health Service Hospitals and some Government Departments run specialist courses, sometimes for their own employees but often for all comers, including participants from other countries. Sometimes, attendance must be restricted, for example, for the Royal Naval College's three months course in nuclear radiation protection, and the Home Office's two-week course in radiological protection for senior Fire Service Officers. Radiological protection features in the training syllabus of certain craft and other institutes including that for para-medical personnel (chiropractors).

In common perhaps with other countries, there is no university course leading to a first degree in radiological protection as such; this accords with the concept that health physics is a profession and not a "subject". Regarding the post-graduate MSc courses in radiological protection, the demand for places is limited and hence their provision has reduced considerably from a few years ago. This is a consequence of a preference, among radiological safety staff and employers alike, for graduates entering the profession to join employment directly and proceed after a period of job-experience, on intensive specialist courses. Groups with less extensive training requirements, such as part-time safety staff and line operators, need relatively short courses only. The general preference in the United Kingdom therefore is for intensive or short courses.

#### 5. NATIONAL RADIOLOGICAL PROTECTION BOARD COURSES

The Board, in fulfilling its special responsibility in radiological protection training, at present provides two types of courses in addition to assisting the Universities and Technical College with theirs.

- a comprehensive four-week courses at post-graduate and at advanced levels, covering all aspects of radiological protection and designed for full-time health physics staff;
- b short courses at other levels to cater for the varying needs of a wide range of users of radiation sources and for those who may have to deal with incidents involving radioactivity.

The post-graduate course meets initial and early training requirements of those entering health physics; the advanced course is for the experienced health physicist. Both the courses are, however, also relevant to the training of other staff having responsibilities in radiological protection, including medical officers. About half the lecturers are from the Board; the remainder come from the large nuclear energy organisations, research and government departments, universities and specialist institutions. Both courses take place annually. Attendances average thirty persons per course of which twenty are from United Kingdom establishments. For the present series which commenced in 1969, the total attendance is four hundred and fifty persons of which one hundred and fifty come from thirty one different countries, mainly from Western Europe but including Africa, North and South America, Asia and Australia. A feature of these courses is that they

---

\*An independent body (founded in 1878 and granted a Royal Charter in 1900) which on a national basis provides syllabuses of courses, arranges examinations and awards certificates in a wide range of subjects at various levels, for example, operative, craft and technician.



constitute a widely representative international forum for the exchange of information and ideas.

As regards the short courses, the Board's technical services Centres advertise courses of one to five days duration, organised either directly or in conjunction with other bodies such as universities and technical colleges. These courses are pitched at various levels, and are intended for users of radioactive materials and X-ray machines, such as industrial radiographers and radiochemists, dentists, doctors, nurses, the staff of research and educational establishments, safety officers, X-ray engineers, the police, the fire services, transport services and security officers; there are also courses for persons with responsibilities pertaining to public health and the protection of the environment. Special courses to suit the purposes of particular groups are also arranged. Short courses are also held on industrial firms premises if requested, specially tailored to suit their needs. Recently, courses dealing with the hazards from lasers and ultra-violet radiation have been held.

The Board's short courses, with their flexibility of standard, scope, dates, duration and venue, cater in large measure for the training requirements of diverse groups of persons in widespread locations. They also help to overcome the problem of the small industrial user with limited needs involving only a few employees who cannot be spared to attend courses far away from their place of work. The Board presents an average of fifty such courses annually, attended by about seven hundred persons.

Apart from formal training courses, the Board holds scientific seminars for its own staff and persons from relevant organisations; special seminars are held for Members of Parliament, senior officials, the Press etc. on subjects of public interest and debate. For example, several have been held on plutonium and radioactive waste management. Tutorial seminars are provided for special groups such as persons liable to provide expert first-line assistance in the event of radiation incidents that might involve the public, eg, transport accidents.

In pursuing its policy of encouraging other bodies to provide courses, the Board appraises and provides advice on curricula to universities, technical colleges and training centres, and makes staff available as lecturers. It provides the examiner for the City and Guilds of London Institute examinations in radiation safety practice. The Board's staff support appropriate national (and international) scientific and other bodies at their symposia, conferences and meetings. Talks are given at informal events sponsored by local social and educational societies but the demand for these is small. The Board issues training publications at both the non-specialist and scientific level, collaborates in the production of training films and participates in the appropriate television and radio programmes.

## 6. CONCLUSION

Broadly, the United Kingdom has a range of courses wide enough in scope, standard and duration to meet the needs of the groups requiring training in radiological protection, and some of the needs of other countries. The special responsibility placed upon the National Radiological Protection Board provides the UK with a statutory body invested with a central role in the provision of training and the maintaining of standards. Hence, the organisation exists for the coordinated expansion of training to meet evolving needs and requirements.

THE SYSTEM OF TRAINING AND FURTHER EDUCATION IN RADIATION  
PROTECTION IN THE GDR

G. Sitzlack, K. Neumcister

Staatliches Amt für Atomsicherheit  
und Strahlenschutz der Deutschen  
Demokratischen Republik

As a central state authority, the Nuclear Safety and Radiation Protection Board of the GDR is responsible for the organization of radiation protection training and, according to its statute, has to take measures of training and further education on its own. The requirements of radiation protection qualification vary depending on the type of activity and responsibility and have been laid down by law for the GDR in the Radiation Protection Ordinance. With respect to working tasks and ranges of responsibility, three main categories of persons with knowledge in the field of radiation protection can be distinguished: 1. radiation protection experts (radiation protection officers and medical officers responsible for supervising occupationally exposed personnel), 2. responsible managers/staff, 3. other personnel. In the enterprise, the observation of radiation protection regulations is checked by the radiation protection officers and measures of medical surveillance are taken by the responsible medical officer. From 1962 to 1976, more than 13,000 persons were trained in more than 400 courses. For this group of persons these training efforts are the basis of a well-founded special knowledge. With their aid it was possible to bring a certain percentage of the public to understand the problems of radiation protection and of general emergency planning. This also concerns the uses of nuclear energy. All training measures are of a highly prophylactic value. At the same time they are an important step in avoiding confuse discussions in the public. The basic training of responsible staff to acquire the State Certificate is carried out in terms of one-day colloquies. These courses are held separately as to the application fields of process instrumentation and control engineering, handling of sealed radiation sources and unsealed radioactive materials, technical X-ray application and the medical application of radiation. The attendance of the mostly two-day colloquies is compulsory. In these courses, giving ample room for discussions, a written examination has to be passed, which in case of positive assessment, ends in the granting of the State Certificate. The curricula comprise: organization of radiation protection in the GDR, licensing procedure, handling of sealed radiation sources or unsealed radioactive materials, occupationally exposed persons, unusual occurrences a.o.

The basic training of radiation protection officers consists of a theoretical part and 1 to 3 practical courses, depending on the field of application. The courses last 1 week each.

It is the aim of basic training to make the future radiation protection officers familiar with their later tasks, which they have to meet as control authorities in the enterprise and in facing the results of unusual occurrences. Therefore, besides a very good knowledge of legislation in the field of radiation protection, great importance is attached to a good knowledge of working behaviour in the respective scope of duties, and of course also of the biological, physical and technical fundamentals of radiation protection. Within theoretical basic training, thematically separated courses for radiation protection officers in the fields of radionuclide application, process instrumentation and control engineering, and the use of X-ray generators are held several times a year. The subject matter is imparted by means of lectures and supplementary seminars. The theoretical courses are completed with a written examination each. The successful attendance of courses is certified. Only after a completed basic training the State Certificate for Radiation Protection Officers is granted. The practical basic training of radiation protection officers falls into 3 practical courses. The trainees have to make tests on their own in groups of two, have to put them down in a protocol and, in talks with the lecturers, have to show a sufficient knowledge of the problems involved in the respective task and of legal regulations and standards of radiation protection. We distinguish between practical courses for the application of sealed radiation sources, the application of unsealed radioactive materials and the use of X-ray generators. The courses comprise: measuring techniques, dosimetry, contamination monitoring, decontamination a.o.

The theoretical basic training of responsible medical officers is carried out in 2 one-week courses. Interest is focused on medical-biological problems with case discussions, assessment of working places, assessment of radiation injuries, physical-technical fundamentals of radiation protection and legislation in the field of radiation protection. After a completed basic training the State Certificate for Responsible Medical Officers is granted. At present, a medical-biological practical course in radiation protection for physicians is being prepared.

Radiologists undergo a special training in radiation protection. This consists of a two-week theoretical and practical course, held in the 4th or 5th year of further education as a specialist, and its successful completion (oral examination) is the precondition for licensing as specialist for radiology. The curricula comprise: radiation protection laws and problems of insurance law, physics of radiation protection, measuring techniques, radiation protection medicine and working behaviour. The practical course includes dosimetry, measuring techniques, contamination monitoring a.o.

At present, there are more than 40,000 occupationally exposed persons in the GDR. They are qualified by means of instruction courses in the enterprise and fall within "other personnel". These courses have to be held according to an instruction programme confirmed by the Board, for which a skeleton programme has been decreed.

The presented system of basic training has proved a success. The rapid development in all medical, scientific and technological fields, however, calls for a continuous further education in radiation protection. This has been laid down in the Ordinance Concerning Further Education in the Field of Nuclear Safety and Radiation Protection of 1975. At present, we are launching a cycle of advanced training courses, which includes all trained personnel in a 2-to-5-year turn depending on their field of work. In these courses the knowledge imparted and the skills acquired in basic training are to be strengthened and extended in agreement with the latest results of science and the requirements of practice. During courses the knowledge and skills in the field of radiation protection are checked. Advanced training courses will be held partly as one-day colloquies or partly as several-day courses, including special practical courses or demonstrations. In this respect the medical-biological part of training and further education will be stressed more in the future, proceeding a.o. from the fact that the understanding of biological-medical processes after radiation exposure is an important motive for optimally observing radiation protection regulations.

From September 1, 1977, highly specialised experts will embark on a postgraduate study of nuclear safety and radiation protection, demanded by radiation protection experts as a possibility for further deepening specialist knowledge. This postgraduate study is carried out by the Nuclear Safety and Radiation Protection Board of the GDR. It has the following thematic priorities:

- Systematic representation of mathematical-scientific and technological basic subjects and practising of the skills required,
- Imparting of the necessary biological and radiation protection medical basic knowledge,
- Representation of the state and both national and international trends of safety problems in nuclear energy uses and in other applications of ionising radiation including legal problems.

The postgraduate study is carried out in terms of extramural study for 3 terms and is completed with a final thesis and respective examinations. In its present form, this study holds for biologists, physicists, chemists and engineers with state diploma. On successfully completing the postgraduate study the postgraduates are granted the title of "specialist biologist, - physicist, - chemist or - engineer for

radiation protection" in addition to their title of occupation acquired by graduation. Within the mentioned thematic priorities there are the following groups of study subjects, taught by means of lectures, seminars, exercises, excursions and home study:

Methods of statistical analysis,  
Fundamentals of nuclear physics,  
Measuring techniques in the field of radiation protection,  
Isotope and radiation technology,  
Radiobiology,  
Medicine in the field of radiation protection,  
Radiation hazards and radiation protection limits,  
Surveillance of personnel and working places,  
Behaviour in case of unusual occurrences,  
Planning and organization of radiation protection institutions,  
Problems of radiation protection in nuclear power plants,  
Nuclear fuel cycle,  
Problems of radiation protection in mines,  
Radwastes and transport of radioactive materials and nuclear fuels,  
International problems of the peaceful uses of nuclear energy,  
Emergency planning.

Training and further education in the field of radiation protection in the GDR is a closed system constituted by systematic stages, which can be considered a successful regulation. Measures of training represent an essential basis for optimally observing radiation protection regulations.

HEALTH PHYSICS ASSISTANT - A SPECIAL TRAINING IN  
HEALTH PHYSICS IN THE FEDERAL REPUBLIC OF GERMANY

H. Kiefer

W. Koelzer

Karlsruhe Nuclear Research Center  
Health Physics Division  
7500 Karlsruhe, Fed. Rep. of Germany

The expansion of nuclear research, the large-scale economic use of nuclear energy for electricity generation and the increasing number of radioactive substances and ionizing radiation used in medical applications entail continuously rising requirements to health physics staff regarding not only its number but even more the quality and degree of training. So, in addition to training technical health physics personnel to be instructed within a short period about the performance of routine tasks in particular fields, special expert staff will have to be trained in the future who will be capable to recognize and solve health physics problems due to the well-funded varied health physics training they have received over several years.

In the Federal Republic of Germany knowledge in health physics is imparted mainly as a supplement training in courses of some days up to a few weeks duration. This may be adequate for strictly defined sectors, although it is not sufficient as to the education of a true health physicist. Already in the early sixties the necessity of such special training was recognized at the Karlsruhe Nuclear Research Center and training was started of "healths physics assistants" as we call this profession.

The problems to be solved by health physics assistants in the execution of their occupational duties from the very outset made it clear that the training objective could be met only by means of the dual training system: practical training in a nuclear facility, the Karlsruhe Nuclear Research Center in this case, and theoretical education, to back up and add to the knowledge acquired, in a vocational or technical school. This dual type of training imparts both the technical, practical knowledge, i.e. the skill and the theoretical aspect, i.e. the knowledge of one's occupation.

Training at the Karlsruhe Nuclear Research Center was begun on the basis of this concept in 1960; to this day, 1977, this agency has remained the only training facility for this vocation in the Federal Republic of Germany. By 1976, 72 health physics assistants, mostly ladies, had completed their training courses with a final examination, 15 are presently undergoing their training.

Roughly one third of the health physics assistants began their careers in jobs at the Karlsruhe Nuclear Research Center or have stayed with the Center, others work in nuclear industry, in reactors, research institutions and hospitals with nuclear medicine sections, not only in the Federal Republic of Germany, but also abroad and with international organizations.

The training takes two years; courses always begin on September 1 of a year. As a result of the small number of training facilities available, no breakdown into age groups is attempted either for the practical or the theoretical part of the training. Admission to the courses requires the leaving examination of a high school (the German Abitur), a rule which has not been adhered to only in a few cases so far.

The practical curriculum encompasses all areas of health physics and is implemented mainly at the Karlsruhe Nuclear Research Center. The duration of practical training in the areas listed below is a function of the significance of each of these fields; it varies between 1 and 3 months.

- Work station monitoring in scientific institutes, reactors, accelerators.
- Environmental monitoring.
- Water and liquid effluents monitoring.
- Dosimetry (RPLD, TLD).
- $\alpha$ - and  $\gamma$ -spectroscopy,  $\beta$ -energy determination.
- Incorporation measurement (human body counter, lung counter).
- Radiochemical analysis.
- Maintenance and calibration of measuring equipment.
- Health Physics in nuclear medicine (in connection with the Vincentius Hospital of Karlsruhe).
- Radiation protection management (Atomic Energy Act, Radiation Protection Ordinance, nuclear safeguards).

One feature of the practical training courses is the possibility to have a look over the fence, as it were, by attending health physics courses organized at a foreign institution, in this case the Service Central de Protection contre les Rayonnements Ionisants (S.C.P.R.I.) of Le Vésinet, France, and a supranational institution, the European Institute of Transuranium Elements run by Euratom at Karlsruhe.

Theoretical education includes the following fields:

- Lectures in special areas (mathematics, atomic physics and nuclear physics, biology and electrical engineering) at a vocational school (one day a week).
- Lectures on "basic principles of health physics" and "radiations protection measurement" at the University of Karlsruhe.
- Special courses of 1 to 3 weeks at the Nuclear Engineering School of the Karlsruhe Nuclear Research Center (basic course and supplementary course in health physics, radiochemistry laboratory lessons).



The training courses are completed with a practical examination (to be carried out over a period of two weeks) and a theoretical examination (written test paper and oral exam).

The training costs are paid in full by the Gesellschaft für Kernforschung; the trainees are granted a monthly training allowance of DM 600 - 700.

After the successful testing and execution, for a period of 15 years, of such health physics assistance training it was found necessary to seek government recognition of this training course and the final examination. We felt that the dual training system had to be retained at all cost, because it is characterized by its closed integration of theory and practice. A course of studies purely geared to the system of a technical school or university would be too theoretical for purposes of practical health physics. For this reason, a solution was adopted which involved cooperation with the Vocational Academy of the State of Baden-Württemberg, because the main characteristic of that academy, unlike the general trend in this country, is the connection of specialized scientific and practical professional training. Theoretical education with the government-supported Academy and practical vocational training alternate for periods of 3 months each. In this way the positive experience with the dual training system can be conserved and the desired government recognition of this training course is now even enhanced by government supervised training connected with a state examination. Moreover, there is a possibility of a follow-on course: after at least one year of successful activity as a health physics assistant a trainee can add one year's course of studies to graduate with the state examination of "health physics engineer." Following the conclusion of negotiations still under way, the new kind of training is to be started on October 1, 1977; the present curriculum will remain unchanged. The number of applicants is high: there are more than 200 for 12 vacancies.

## FORMATION DU PERSONNEL DES CENTRALES NUCLEAIRES EN RADIOPROTECTION

K. Brosson - Y. Lambinon  
Service de la Production Thermique  
d'Electricité de France

## 1. ORGANISATION ET FORMATION

La radioprotection est une action de sécurité vis-à-vis d'un risque particulier dû aux rayonnements ionisants.

À E.D.F. on admet le principe que la sécurité est l'affaire de tous les travailleurs : chacun est responsable de sa propre sécurité et de celle de son environnement.

Ce principe exige que chaque agent soit capable d'assumer cette responsabilité, principe matérialisé par la délivrance d'habilitations.

Cela implique qu'il ait reçu au préalable une formation en matière de sécurité adaptée à sa fonction.

FORMATION et ORGANISATION sont donc étroitement liés.

## 2. CONTENU ET REPARTITION DE LA FORMATION

L'objectif de la formation est que chacun acquiert la "maîtrise du savoir faire" nécessaire à la bonne exécution de la tâche qui lui est confiée.

Il faut donc commencer par effectuer une analyse et une répartition des tâches pour définir le contenu de la formation.

Pour cela il est utile de se reporter au schéma suivi en matière de sécurité.

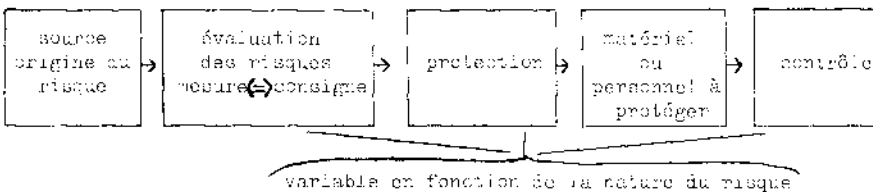

Soit en radioprotection

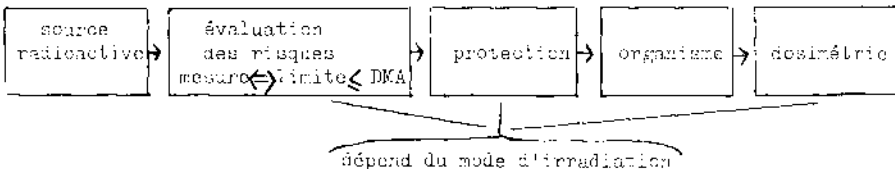

Ainsi apparaissent deux grands types de tâches à effectuer :

- Les tâches d'évaluation des risques
- Les tâches de protection auxquelles nous rattacherons les tâches de contrôle corporel.

Compte tenu que tout travail s'effectue sous la responsabilité d'un chef de travaux habilité qui doit assurer non seulement sa propre sécurité mais également celle de l'environnement de son chantier on voit que :

tout le personnel recevra une formation visant aussi bien à la maîtrise de la protection individuelle lorsque l'évaluation des risques a été effectuée qu'à la maîtrise du contrôle corporel (contrôle de contamination externe et dosimétrie d'irradiation externe)

Les chefs de travaux recevront une formation visant à la maîtrise de l'évaluation des risques.

En ce qui concerne cette dernière tâche, l'expérience montre que l'on peut distinguer celle qui se situe :

d'une part, dans le cadre routinier (débit de dose  $\gamma$  en irradiation externe, contamination superficielle et volumique par radioémetteurs  $\beta$ )

d'autre part, dans le cadre exceptionnel (risques dus aux émetteurs  $\alpha$ , à l'iode, tritium, neutrons etc...).

Seule l'évaluation des risques dans le cadre routinier qui ne requiert pas une trop grande technicité sera confiée au chef de travaux habilité sous la responsabilité duquel s'effectue le travail.

L'évaluation des risques dans le cadre exceptionnel demande une technicité plus importante et relève du spécialiste de mesures qui fixera les consignes selon lesquelles devra s'effectuer le travail.

### 3. PROGRAMMES DE FORMATION

Cette maîtrise d'un savoir faire, nous entendons qu'elle soit véritablement intériorisée par les formés. Par suite il est nécessaire qu'elle passe par une compréhension intelligente et réfléchie de la tâche pour la différencier d'une maîtrise mécaniste qui passerait par un conditionnement des formés. Nous la désignerons par "appropriation".

Ainsi le premier palier de formation, destiné à tout le personnel, vise l'appropriation de ce qui relève de la PROTECTION et du CONTRÔLE CORPOREL.

Mais afin que la communication soit plus aisée et la compréhension encore meilleure, il convient de "démystifier" les tâches du "niveau supérieur".

Dans cette optique, tout le personnel effectue au moins une fois l'évaluation des risques dans le cadre routinier mais sans en viser l'appropriation.

La formation comprend donc :

- une phase d'APPROPRIATION
- une phase d'OUVERTURE vers le niveau supérieur ou DEMYSTIFICATION.

Après la formation, des séances d'information sont programmées pour répondre aux questions que se pose le personnel.

Le schéma ci-dessous illustre les différentes formations et leurs objectifs

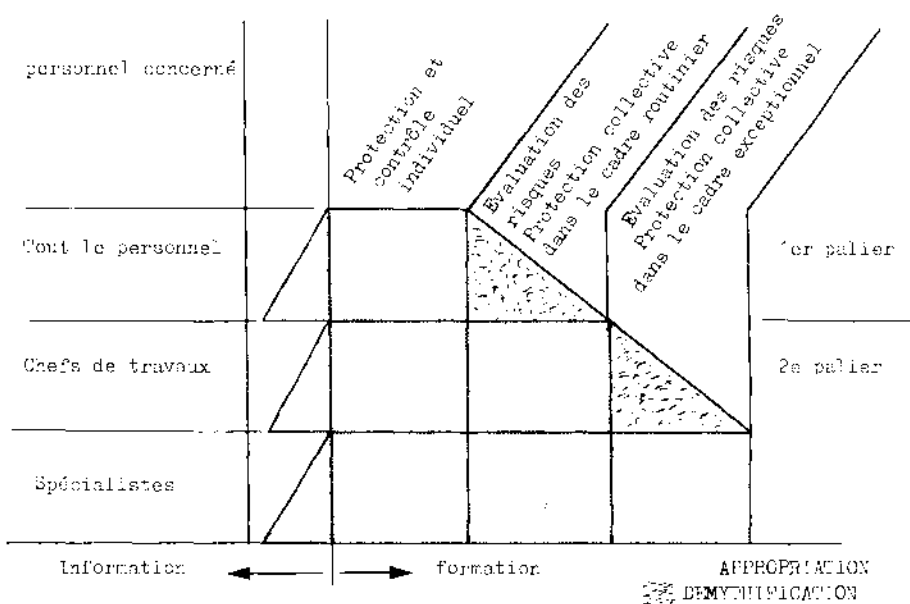

Ainsi, les programmes 1er et 2ème palier, 2ème palier et formation de spécialistes de secours, sont sensiblement les mêmes mais leurs objectifs sont différents. Par exemple l'évaluation des risques dans le cadre routinier relève de la DEMYSTIFICATION au 1er palier mais de l'APPROPRIATION au 2ème palier.

Chaque palier dure une trentaine d'heures et la formation se fait sur le site de chaque centrale.

Il existe en outre un recyclage au niveau de chaque palier ainsi qu'une formation plus spécialisée destinée aux ingénieurs.

#### 4. METHODES ET MOYENS

La formation se fait par paliers de complexité croissante à partir de questions concrètes que l'on se pose en situation professionnelle. Les apports théoriques se font au fur et à mesure des besoins et les méthodes pédagogiques utilisées aussi "actives" que possible.

Les formations 1er et 2ème palier se faisant sur le site, afin d'être plus proches de situations réelles, les formateurs seront des agents d'encadrement de la centrale.

Afin de faciliter le travail de nos formateurs occasionnels, et d'homogénéiser les divers enseignements, les moyens suivants sont à disposition :

- sur le plan humain : un stage de formateur en radioprotection (stage 3e palier)
- sur le plan matériel : des dossiers pédagogiques.

Un dossier pédagogique comporte :

- un "CENDEF" de séance, explicitant l'objectif de la séance, les points clés devant être assimilés (les points clés sont les étapes permettant d'atteindre l'objectif) et le déroulement possible de séance
- des Outils pédagogiques permettant de concrétiser l'enseignement (irradiateur, batterie d'écrans, chantier école ... etc).

#### 5. ORGANISATION PRATIQUE DE LA FORMATION EN RADIOPROTECTION

Nous venons de voir le côté particulier des méthodes et des moyens utilisés en matière de formation en radioprotection.

Actuellement 600 agents environ doivent être formés annuellement suivant ces méthodes pour le 1er palier, 200 pour le 2ème palier, plus environ une quarantaine de spécialistes.

Une trentaine de formateurs en radioprotection sont formés annuellement.

La décentralisation a également demandé la reproduction des dossiers et auxiliaires pédagogiques (coût 80 000 F pièce) en autant d'exemplaires que de sites nucléaires.

L'enseignement destiné aux spécialistes et aux instructeurs est centralisé et assuré par les ingénieurs et techniciens du Département de Radioprotection du Service de la Production Thermique.

#### 6. CONCLUSION

Le désir s'étendre à la radioprotection l'organisation en matière de sécurité adaptée à E.D.F. a demandé un effort particulier sur le plan de la formation du personnel et la mise en oeuvre de méthodes et de moyens d'un coût relativement élevé.

Nous nous sommes heurtés à de nombreuses difficultés par exemple avec certains "anciens" du nucléaire qui avaient été formés d'une manière plutôt encyclopédique et qui trouvaient tout souvent trop simple (nous ne parlons effectivement pas de Brestrahling !) mais nous avons l'impression d'être maintenant sur la bonne voie.

## A NEWLY ESTABLISHED COURSE IN RADIATION PROTECTION FOR VETERINARY AND AGRICULTURAL POST-GRADUATES

Victor Middelboe  
Physics Laboratory  
Royal Veterinary and Agricultural University  
Copenhagen, Denmark

### 1. INTRODUCTION

The use of radioactive isotopes as tracers in veterinary and agricultural<sup>\*\*)</sup> science is becoming the rule rather than the exception. Consequently, an appropriate degree of radiation protection in these fields of research is increasingly important as a part of the general scheme of environmental protection.

Two years ago the physics courses given by our department were undergoing revision, and simultaneously we took the opportunity to re-consider the education of students in radiation protection. The outcome of the latter considerations was the introduction of a post-graduate course entitled "Health Physics and Isotope Hygiene". Before entering into description of this newly established course, a brief review of the foregoing history is presented.

### 2. THE ORIGINAL ISOTOPES COURSE

Once or twice annually from 1958 to 1972 we presented a course in isotope techniques to veterinary and agricultural post-graduates. An average of 12 students per year participated and the time allotted per course was about 90 hours of instruction evenly distributed between the lecture room and the laboratory. A general impression of the course curriculum may be obtained by conferring the subject matter given in the common basic part of several IAEA publications, the latest being the revised manual on crops and soils ( 1 ).

The main objectives of the course were ( a ) to instruct the participants in the use of isotopic tracers and ( b ) to train the participants in the handling of radioactive materials at the tracer level without undue risk to them-

---

<sup>\*\*)</sup> "Agriculture" is used in this manuscript to cover agriculture as such, dairy-engineering, horticulture, food technology, and forestry.

selves or others. As a consequence of the second objective, the short chapter on radiation protection in the above-mentioned tracer manual was supplemented over the years with texts from other publications (2-4). Upon completion of the course the participants underwent a written examination, the result of which was evaluated by The Lecturer in Charge and two Censors ( a physicist and a health physicist ). A diploma was issued to all participants who passed the examination.

### 3. AUTHORIZATION SYSTEM IN DENMARK

Normally, anyone in Denmark who wishes to use radioactive material must obtain permission from the appropriate Health Authority. The diploma mentioned above does not in itself constitute a legal licence. However, the diploma serves as a documentation of special training to which the research worker can refer in his or her application to the authorities.

At each stage of development of a given type of course dealing with radioactive materials certain requirements pertaining to the pensum in radiation protection have been recognised by the authorities as being desirable. Our original isotopes course was among those that essentially fulfilled the stipulated requirements.

### 4. THE INTERMEDIARY PERIOD 1973 - 75

In 1973 a voluntary system of course selection was introduced for most of the undergraduates at our University. Advantage was taken of this situation to open the isotopes course, not only to post-graduates, but also to undergraduates who had completed one year of basic studies. The philosophy being that an acquired knowledge on the use of isotopic tracers would support certain contemporary or subsequent undergraduate studies.

During the period 1973 - 75 it became apparent that conflicting interests were involved concerning the training in radiation protection. The undergraduates were not likely to be made personally responsible for the handling of radioactive material for years to come - if ever, whereas the post-graduates in most cases were on the verge of independent research in which they were planning to use one or more radiotracers.

In late 1975 the decision was taken to resolve the problem by establishing two courses instead of one, namely a basic course in isotope techniques and tracer methodology for undergraduates as well as post-graduates, and a supplementary course in health physics and isotope hygiene

for post-graduates.

The basic course comprises 74 hours of instruction in theory and practice, and only a small part of the time is allotted to training in radiation protection. No special diploma is issued.

## 5. THE NEW COURSE IN RADIATION PROTECTION

The supplementary course, which deals mainly with relevant aspects of radiation protection, comprises 48 hours of instruction evenly distributed between theory and practice.

Eligible for the course are post-graduates ( and senior undergraduates ) who have taken the basic course and passed the examination satisfactorily. Candidates from other colleges or universities are admissible on the same ( or equivalent) conditions.

The main objective of the course in health physics and isotope hygiene is to provide previous participants in the basic course with a supplementary education, which the national radiation protection authorities deem to be appropriate for veterinary and agricultural research workers who, under personal responsibility, intend to apply radioactive material at the tracer level.

The subject matter of the supplementary course is taken from two international publications ( 4, 5 ), a number of laws, regulations and instructions printed by domestic authorities, and from other sources of relevant information. An outline of the present course curriculum is given below.

### Lecture Matter

- Health physics units and their applications.
- Limits of exposure dose and isotope contamination.
- Health physics instruments, their function, calibration and use.
- Protection against external radiation.
- Protection against internal and external body contamination.
- Detection of radiation by thermoluminescence and by photographic emulsion.
- Planning of tracer experiments and procurement of isotopes.
- Treatment and disposal of radioactive waste.
- Laboratory features, accidents, medical checks, responsibilities.
- Legal restrictions, control measures, help and advice services.



## Practicals

- Absorption of beta-radiation.
- Attenuation of gamma-radiation.
- Dose control and use of gloved box, etc.
- Decontamination and monitoring.
- Analysis of isotope uptake by autoradiography.
- The use of thermoluminescence.

## Excursions

- The National Institute for Radiation Hygiene.
- Department of Health Physics, The Danish Atomic Energy Research Establishment.

All participants who complete the supplementary course and pass the examination ( evaluated by the teacher and a health physicist ) receive a certificate to that effect issued by the Royal Veterinary and Agricultural University.

## REFERENCES

- ( 1 ) MIDDELBOE, V., NIELSEN, D.R., RENNIE, D.A., "Tracer Manual on Crops and Soils", International Atomic Energy Agency, Vienna ( 1976 ).
- ( 2 ) BOURSNEILL, J.C., "Safety Techniques for Radioactive Tracers", The University Press, Cambridge ( 1958 ).
- ( 3 ) IAEA Safety Series No. 1, "Safe Handling of Radioisotopes", International Atomic Energy Agency, Vienna ( 1962 ).
- ( 4 ) IAEA Safety Series No. 9, "Basic Safety Standards for Radiation Protection", International Atomic Energy Agency, Vienna ( 1967 ).
- ( 5 ) IAEA Safety Series No. 38, "Radiation Protection Procedures", International Atomic Energy Agency, Vienna ( 1973 ).

## INFORMATION SERVICES IN NUCLEAR AND NON-NUCLEAR CONTROVERSIES

M.J. Gaines and L.D.G. Richings  
National Radiological Protection Board  
Harwell, Didcot, Oxon, England

### 1. PAST ACCEPTANCE AND PRESENT CHALLENGE

Until very recently, the British public's attitude to the development of nuclear power for producing electricity was placid. The position has changed sharply; but the persistence of such public confidence over many years is a phenomenon worthy of study, especially as the vigorous, organised public reaction to nuclear weapons, familiar now in many countries, began in Britain.

Various factors have contributed to the British public's acceptance of civil nuclear power. The opening of Calder Hall in 1956 was seen as a "national achievement" and the series of magnox stations that followed were also seen in this light. Their value strategically, in reducing oil imports, contributed to their acceptance; and, despite subsequent denigration in some organs of the national press, they have worked well and produced electricity cheaply and steadily. Local interests were represented on a liaison committee at each nuclear site from the outset and the UKAEA and the Generating Boards issued large quantities of simply expressed technical and other information. The Generating Boards also adopted the sensible policy of encouraging the public to visit nuclear power stations and spent money on ensuring that competent guides were available. The link between the materials used for 'peaceful uses' of nuclear technology and weapons did not seem to be perceived by the public, and was the subject of only isolated comment. Further the 'plutonium economy' was not imminent and has only now served to focus general protest; similarly, the advent of universal terrorism is relatively a recent cause of fear.

The substantial changes in society over the last thirty years has had a large effect. There is unprecedented concern for the environment as such; far less trust of government and industry, with an emphasis on public (even individual) participation in major governmental and industrial decisions; the rising economic expectations of the "less privileged" classes of society; and, in many countries, the relentless pressure of increasing population. In general, there is a great internal conflict - a steady increase in the demand for cheaper and more energy (and the higher standard of life it can bring) competing with an increasing cynicism about the need for a higher standard; and apparent suspicion and fear of the science and technology necessary to achieve a higher standard even when wanted.

Britain is lucky in one respect - it has an abundance of energy in the form of coal (and now oil) and many believe that the waves and the strong tidal currents surrounding her should be harnessed to produce power. These are now additional reasons in the minds of objectors for opposing the use of nuclear power.

### 2. THE NATIONAL RADIOLOGICAL PROTECTION BOARD (NRPB)

The Board was established by the Radiological Protection Act 1970. It is the national point of authoritative reference in radiological protection for the UK. Its principal duties are:-

to advance the acquisition of knowledge on protecting mankind from radiation hazards and to provide information and advice to persons (including Government Departments) with responsibilities in the UK for protecting the community as a whole or particular sections of it from radiation hazards.

NRPB has no role in the promotion of nuclear power; nor is it responsible for its regulation. Because it is independent of government, the nuclear plant operators and the developers, it can occupy a central place in the nuclear debate. For instance, at any one time it could be providing information and advice on, say, the effects on health of radioactive discharges from nuclear installations, to central government and environmentalists, journalists and academic scientists, trade unions and employers, consumer organisations and plant operators, teachers and school children, individual politicians and political parties, women's organisations, church organisations, local authorities, individuals overseas and to international agencies.

### 3. COMMUNICATING

Any public controversy tends to be conducted simultaneously on two broad levels; on one level are the experts and on the other the laymen; but within the latter one can, again broadly, distinguish between the generally well informed and the woefully ignorant. As a general rule, points raised at the expert level determine the course of the lay debate and the nuclear debate is no exception. Consequently, an organisation such as NRPB must, at the very least, provide information and advice at both of these two broad levels. The greatest effort is directed at specialists in radiological protection; but closely following is communication designed for "the informed" layman, particularly those who might influence policy makers as well as the policy makers themselves.

NRPB encourages its staff to publish the results of their scientific work in the open literature and to participate in specialist symposia, conferences etc; it also publishes its own series of technical reports. These reports have covered a variety of radiological problems, quite outside the ambit of power production, for instance, radioactivity in consumer goods, the use of plutonium sources in schools, radon in metaliferous mines, by-product gypsum as a building material, radioactive fluorescers in dental porcelains, etc. From time-to-time, a general review is published describing the current levels of radiation exposure of the public from various sources. Each year a report is published on the study of chromosome aberration yield in human lymphocytes as an indicator of radiation dose; and the significant over-exposures to radiation which it lists come mainly from industrial radiography rather than nuclear power. The Board also publishes "Radiological Protection Bulletin" a quarterly Journal covering the whole field of interest, including comment on attitudes, terminology and policy.

This focussing of attention by an authoritative, expert, independent source of information on radiation from all causes, not just from nuclear power, enables radiological hazards to be seen as a whole and the advantages and disadvantages of using ionising radiation to be better weighed and rational opinions formed.

### 4. THE PROFESSIONALS

When appropriate, the reports are accompanied by a press brief; and occasionally "the press" are briefed individually. The information media in the UK (press, radio and TV) have for many years benefitted by employing specialist "science correspondents". Some of these are science graduates, some not. But nearly all are capable journalists who build up their knowledge and develop informal relationships with the leading figures of science.

With the advent of nuclear power, it was natural for them to become the principal commentators on the subject. They still are, but as industrial uses of radiation have become routine and as the international security aspects have become subject to public scrutiny, other types of journalists have become involved. The regular commentators on diplomatic and defence questions have generally tended to report matters objectively but some other journalists have naturally been more opportunistic in seeking a noteworthy story presented to catch the eye of the reader and the attention of the viewer and listener.

Nevertheless, it is still, more often than not, through the science correspondents that the public usually learn about developments and new controversies in nuclear power and NRPB concentrates on them in its dealings with the "opinion formers". Its programme of press relations includes arranging for individual correspondents to visit the laboratories and to learn of NRPB's work; arranging seminars on particular topics specifically for journalists, eg, on plutonium and health; and press open days, when parties of journalists visit the laboratories, etc.

NRPB considers that bad science needs firm rebuttal, especially when public opinion may be unduly influenced by the circumstances surrounding the product. An example is the "hot particle" hypothesis widely reported in 1974. NRPB on this occasion issued a rigorously argued information sheet which, according to some journalists, was particularly helpful to those under "policy" pressure from editors to support the concern so dramatically expressed.

Of course, journalists with even the best intentions are subjected to the normal pressures in their lives. There are three of these of high importance - time, space and competition. Time is always at a premium. It means that some journalists have to work fast all of the time and all journalists have to work fast some of the time - and this is one of the greatest causes of inaccuracy and misunderstanding. Space is always inadequate. Among other things, this means that it is the abnormal that is reported and the normal that tends to be lost. Journalists have to bear in mind what their employers consider to be "news"; not all success stories are "news", although trouble usually is, and for many journalists the definition of news is simply what he can get on to the air or into his paper. The third pressure on journalists is competition, particularly severe in countries which, like the UK, have national newspapers. For instance, editors scan the early editions of one another's newspapers looking for the stories that their own paper has missed; they have been known to take "exclusives" out of subsequent editions to make way for "good" stories carried by their competitors. Clearly, journalists have their problems and scientists, who sometimes feel that in dealing with the journalist checking a story against a dead line that they are being harassed by the corporate might of newspaper chains or TV companies, should remember that they are probably dealing with an individual journalist who is just trying to solve his own immediate problems.

## 5. THE PUBLIC

Clearly, because of the vagaries of the information media, it is essential sometimes to try to communicate directly with the general public and, with this in mind, NRPB published a booklet, "Living with Radiation", in 1973. It has been re-printed three times and 25,000 copies have now been produced. It seems particularly popular with schools and colleges.

NRPB and the British Society for Radiological Protection also offer speakers for meetings of private organisations of all sorts, eg, Round Table; Women's Institutes; Townswomen's Guilds, etc., but there has been (perhaps surprisingly in view of the press and political debate of the last two years)

scarcely any demand. NRPB has, however, dealt with a steady stream of enquiries from individuals, especially from students who find that "projects" on pollution and on radioactivity have become very popular with their teachers.

In the course of the current "public debate" in Britain, stimulated by the Secretary of State for Energy, there have been a few open public meetings - as distinct from "organisational" meetings held in public. NRPB send people to both types of meetings to inform the debaters in a neutral, objective way of the facts relating to the hazards and the means of protection.

In any controversy, it is very tempting for an organisation trying to be neutral to refuse to comment. No matter how objective it is, if a clear statement is made, one side will accuse it of siding with the other. Then, the organisation's whole credibility is at stake. Credibility cannot be achieved overnight - it has to be earned by the painful effort of many years; it can be lost, however, on a single encounter. For NRPB, it is a fundamental part of its work to provide objective, authoritative advice and information. So far, it has done so without prejudice to its independence and without too much damage to its credibility, even to some of the more emotional opponents of nuclear power.

It is interesting to speculate on whether ICRP should make efforts to communicate with non-scientists, if only to make sure that its recommendations are properly understood.

## 6. NON-NUCLEAR CONTROVERSIES

There are lessons to be learned by those who have a regulatory or advisory role in relation to non-nuclear hazards. Undoubtedly, they will be put in the position, from time to time, where their credibility will be at risk. The result will depend on many factors but if their objectivity and authority is generally respected, their opinion is likely to be accepted in relation to specific matters under debate. It is vital to have a good reputation for quality with specialists in their own and in other fields; this means that they must have organised communications with these people in a way acceptable to them. For scientists, this must mean something along the lines of NRPB's efforts described in this paper. Moreover, it must be seen that the organisation is being "open", that is that it is giving other specialists the opportunity to comment on its research, its recommendations etc., as early and as often as is reasonably practicable. It is only against this kind of background that an organisation can sustain a credible public information programme. Publication in refereed journals, at appropriate meetings, conferences etc., easy availability of reports and other publication, willingness of experts to visit and be visited and to attend public meetings, openness with the media - and being seen to be open - all of these are essential. If, at any time, an organisation leaves an "information void" someone, probably the less informed critics, will tend to fill it. Neglect of information policy and practice can in the end generate folklore that will survive for decades. If that happens no-one should blame the critics - only themselves.

L'ENERGIE NUCLEAIRE ET L'OPINION PUBLIQUE : EMERGENCE D'UN MYTHE

D. AGRAFIOTIS, E. DELARMINAT, G. MORLAT, J.P. PAGES  
 Commissariat à l'Energie Atomique- DPr/LSEES- B.P. n° 6  
 92260 Fontenay-aux-Roses, France.

Rarement le développement d'une technologie nouvelle a été associé à autant d'efforts, en vue de réduire les risques et les nuisances qu'elle est susceptible d'entraîner pour les travailleurs et pour le public, que l'énergie nucléaire. Il semble qu'on puisse dire que les enquêtes épidémiologiques, en vue de connaître les effets des rayonnements ionisants sur la santé (effets différés dus aux faibles doses) ont été poussées jusqu'à la limite de ce que peuvent donner de telles enquêtes (et même parfois un peu au-delà). Si des incertitudes subsistent, il s'agit pour l'essentiel de savoir si les très faibles doses (disons inférieures à un Rad) peuvent avoir des conséquences (probabilité d'apparition de cancers ou de mutations génétiques) proportionnelles à celles qu'on a pu observer pour des doses moyennes ou fortes (quelques dizaines ou quelques centaines de rads) ou pas de conséquences du tout.

On sait que les normes de protection recommandées par la CIPR tablent sur l'hypothèse prudente de la proportionnalité des effets aux doses : ces normes constituent alors des limites qui feraient que les travailleurs soumis aux rayonnements ne courent pas des risques plus élevés que ceux que l'on peut observer dans les domaines d'activités réputés les moins risqués.

D'un autre côté, pour ce qui concerne la sûreté nucléaire, la conception des réacteurs permet d'assurer que le risque d'un accident grave se situe au pire dans la zone des  $10^6$  ou  $10^7$  par réacteur et par an : avec un développement rapide de la production d'électricité nucléaire, le rapport des experts américains réunis autour du professeur RASMUSSEN, souligne que le risque d'un accident catastrophique, reste inférieur à celui de la plupart des catastrophes naturelles ou industrielles. Il s'agit là sans doute d'un risque entrant dans la catégorie de ceux dont Jacques BERNOULLI souhaitait, au dix huitième siècle, que le gouvernement d'un état les déclarât "négligeables".

Tels sont quelques points de repère fondamentaux, au plan technique, de la sûreté nucléaire et de la radioprotection. On voit qu'il s'agit, de l'avis d'experts, de nuisances et de risques minimes.

Pourtant, l'opinion publique réagit parfois d'une façon surprenante, voire paradoxale, comme si elle percevait l'énergie nucléaire comme une technologie dangereuse, inquiétante.

Le paradoxe s'accroît encore si l'on observe que l'évaluation des risques radiologiques est faite en cumulant des hypothèses prudentes ou pessimistes -au moins pour les faibles doses- et qu'une surestimation trop grande de ces risques peut conduire à renoncer à des technologies faisant appel au nucléaire, pour adopter d'autres technologies dont les nuisances sont moins bien connues, mais peuvent être beaucoup plus sérieuses : des hypothèses prudentes ne sont pas nécessairement bénéfiques, il faut leur préférer des hypothèses correctes (même attachées d'incertitudes).

En tout état de cause, on observe aisément un divorce, en la matière, entre l'évaluation "correcte" des risques, faite par les scientifiques et les spécialistes en sécurité, et leur perception déclarée par les différents groupes sociaux ou par des individus particuliers.

Bien plus, on a pu observer, en certaines circonstances, que des tentatives faites pour mieux informer le public peuvent aller à l'encontre de leurs objectifs : le langage scientifique n'est pas entendu. "Si tant de choses sont faites pour nous protéger, c'est bien que c'est encore plus dangereux que nous ne le pensions" : telle est la réaction qui surprend, qui choque parfois l'informateur-technicien de bonne foi. Tout cela semble bien indiquer que la formation de l'opinion publique, en la matière, obéit à d'autres règles que celles de la rationalité technique. Doit-on simplement admettre qu'il s'agit d'une opinion irrationnelle, passionnelle, et passer outre ? La tentation est grande, pour un esprit de culture scientifique, de s'en tenir là. Mais pour le praticien, la nécessité s'impose de comprendre le mécanisme de la formation de l'opinion, dès lors qu'une contestation active pourrait risquer, à un certain degré, d'infléchir ou de remettre en cause le développement de l'énergie nucléaire, et dès lors que celle-ci peut être reconnue bénéfique, au plan économique, social et national. C'est ce qui justifie des investigations pour mettre en évidence les dimensions psychosociologiques qui sont à l'origine d'une opinion parfois déroutante et paradoxale.

Avec la collaboration de plusieurs équipes universitaires (I.U.T. de statistique de l'Université de Grenoble, Institut Français du Pétrole, Institut de Statistique de l'Université de Paris, entre autres) le Laboratoire de Statistique et d'Etudes Economiques et Sociales du C.E.A. (Département de protection) a mené plusieurs enquêtes, auprès d'échantillons d'effectif moyen appartenant à des catégories socio-professionnelles relativement homogènes. Il s'agissait de connaître la position de ces personnes sur un certain nombre de questions qui jouent un rôle dans l'actualité et divisent l'opinion, ainsi que sur des problèmes sociaux, politiques, religieux, voire moraux, moins éphémères. On trouvera en annexe l'un des questionnaires qui ont été utilisés. Les questions sont formulées de façon simple, aussi claire que possible, présentées dans un certain désordre. Les sujets interrogés doivent exprimer leur position par l'une de cinq modalités, allant de l'accord complet au désaccord complet -sans se livrer à une analyse ou à de longues réflexions : la simplicité de la question attire la spontanéité de la réponse.

L'étude des réponses fournies à de tels questionnaires s'est révélée d'une richesse que d'aucuns diraient insoupçonnée. Elle met en évidence une cohérence (ou plutôt un certain nombre de cohérences) entre les opinions -dont certaines sont trivialement évidentes et d'autres sont un peu plus neuves. La réflexion et l'interprétation de ces résultats ne sont pas achevées : elles se poursuivent, en même temps que sont mises en place de nouvelles versions de ce type d'enquête, tenant compte des leçons tirées des premiers essais.

Les corrélations entre les réponses données dans les différents groupes sociaux montrent à l'évidence que les positions prises à propos de l'énergie nucléaire ne sont pas au premier chef motivées par des informations précises de nature technique ou économique, mais plutôt par les images qu'évoque le thème nucléaire chez les sujets interrogés : les positions prises sur le nucléaire apparaissent en effet corrélées à d'autres positions, en particulier à celles prises sur la natalité, la censure, la peine de mort, la famille, le travail, la force de frappe, le Larzac, Dieu, ...etc... On jugera grossièrement de ces corrélations en consultant le graphique 1 où sont décrites les corrélations obtenues à la suite d'une enquête auprès de commerçants grenoblois.

Deux hypothèses extrêmes peuvent être alors en particulier émises sur le processus qui conduit l'individu à prendre position par rapport au nucléaire : - la première, d'inspiration psychanalytique, consiste à dire : le thème nucléaire est un thème de conflit ; il peut donc être reconnu par l'individu

comme un objet d'investissement psychique ; la prise de position est alors, à un certain point, "sublimation" ; cette sublimation s'exprime principalement, relativement aux valeurs sociales admises, suivant deux pôles : un pôle positif (positions conservatrices et positions favorables au nucléaire) et un pôle négatif (remise en cause des valeurs admises).

- la deuxième suppose que la position par rapport au nucléaire résulte d'associations qui surgissent dans l'individu au niveau de l'"imaginaire" ; de ces associations émergent, par le jeu intérieur, des directives traduites par l'avis émis.

Dans la deuxième hypothèse, on insiste sur le rôle déterminant des messages émis par les acteurs participant au jeu nucléaire ; ces messages qui peuvent être traduits en termes d'associations et de mythes sont en partie reçus par l'individu (cette perception est fonction des facteurs socio-culturels) ; les associations internes, puis les directives résultent des messages accumulés par l'individu récepteur.

Mais s'il y a sublimation à propos de l'objet "centrales nucléaires", la prise de position fait, malgré tout, référence aux associations apparaissant au niveau de l'imaginaire ; les associations sont alors exploitées en tant qu'éléments permettant une justification à posteriori de la position prise ; c'est la potentialité "rassurante" pour rationaliser qu'offrent les associations qui rend possible ici la sublimation. Dans la réalité, il est plausible que les mécanismes décrits par les deux hypothèses interviennent simultanément, avec une force variable selon les individus.

En tout état de cause, on est conduit à s'interroger sur le processus qui aboutit chez l'individu à l'émergence des associations ; à l'origine de ce processus on trouve en particulier tous les messages qui circulent ou qui ont circulé dans le public à propos du nucléaire.

Rappelons succinctement que dans la théorie moderne de la communication et du langage, les éléments de base des messages sont les signes, couples d'un signifiant et d'un signifié -et les mythes, objets dérivés dans lesquels un signe est pris comme signifiant, auquel on attache un signifié secondaire, ou parasite, qui est souvent l'objet d'un consensus social. On explique ainsi le mythe de l'automobile, dont le signifié secondaire est relatif au statut social de celui qui possède et utilise cet objet, les divers mythes liés à la mode, etc...

Dans le cas qui nous occupe ici, l'énergie nucléaire est de façon immédiate pour le technicien ou le scientifique un concept ordinaire, ou un signe dont le contenu (signifié) est un système producteur d'énergie, à partir d'uranium, selon certaines filières technologiques et dans des conditions économiques précises, etc... -tandis que pour beaucoup de personnes interrogées, et pour le technicien de façon moins immédiate, il s'avère que l'énergie nucléaire est un mythe, auquel est attachée une signification secondaire qui n'a rien à voir avec la production d'énergie (par un détournement de sens, selon l'expression de R. BARTHES).

Ce signifié secondaire, varie, nous l'avons vu, avec les individus, de sorte que l'on pourrait parler d'un "multimythe". Pour un certain nombre de gens, le sens dérivé a une connotation négative (mort, ou mise en danger de l'humanité) ; c'est sur cet aspect du mythe que peut s'appuyer une contestation de l'énergie nucléaire. Pour une catégorie plus sophistiquée, le sens secondaire du mythe est relatif à la forme d'organisation sociale, hypercentralisée, qu'entraînerait, selon eux, le développement de l'énergie électro-nucléaire (l'électrofascisme) -et cette version du mythe commence à supplanter la



précédente dans une partie des supports qui véhiculent la contestation (presse hebdomadaire et mensuelle notamment) ; pour d'autres le sens dérivé a une connotation positive (patrie, défense des valeurs morales, progrès ...) ... etc ...

Comment peut-on lutter contre un mythe ? Roland BARTHES nous indique qu'en cette affaire, l'argumentation rationnelle est parfaitement impuissante, puisque la personne qui adopte le mythe, par définition, n'est généralement pas consciente qu'il s'agit d'un mythe, dont elle est en quelque sorte la victime (intellectuelle s'entend). Si vous argumentez sur le plan du signifié secondaire, elle vous répliquera par un argument portant sur le signifié primitif, et vice versa, profitant sans s'en rendre compte du "détournement de sens" que constitue le mythe. C'est bien ce qu'ont pu constater (parfois à leur détriment) les techniciens qui ont eu l'occasion d'argumenter avec les contestataires du nucléaire. On serait aisément porté à taxer ceux-ci de mauvaise foi : à tort la plupart du temps, puisqu'ils argumentent sur un mythe, qu'ils croient être un concept rationnel, et c'est là le propre du mythe. Ce n'est donc pas le technicien qui saura lutter contre le mythe négatif : il y faut d'autres moyens.

#### REFERENCES BIBLIOGRAPHIQUES

1. C.I.P.R. - Protection contre les rayonnements. Recommandations de la Commission Internationale de Protection Radiologique. Publication C.I.P.R. N° 9 - 1963.
2. U.S. Atomic Energy Commission - "Reactor safety study" Wash 1 400 - 1974.
3. O.M.S. - Les questions de santé mentale que pose l'utilisation de l'énergie atomique à des fins pacifiques. Rapport 151 - 1957.
4. GUEDENY C. et MENDEL G. - L'angoisse atomique et les centrales nucléaires - Payot, Paris - 1973.
5. BRUSSON G. , FAGNANI F. , MORLAT G. - Etude coûts-avantages dans le domaine de la Radioprotection - Colloque IAEA -Portoroz - 1974.
6. BARTHES R. - Mythologies - Ed. du Seuil - 1970.
7. Relations et Influences Réciproques entre public et décideur dans certains choix industriels. Le cas du risque nucléaire. Rapport d'une recherche C.N.R.S. - C.O.R.D.E.S. dirigée par F. FAGNANI.
8. AGRAFIOTIS D., MORLAT G., PAGES J.P. - Le public et le nucléaire. Conférence Internationale sur l'Energie d'origine Nucléaire et son cycle de Combustible. - Salzbourg MAI 1977.

---:---:---:---:---:---:---:---

## TABEAU 1

### Questionnaire

1. La libération de l'avortement est une bonne chose
2. Il faut continuer à construire des centrales nucléaires
3. Les médecins méritent notre confiance
4. Il faut diminuer l'importance des diplômes
5. Dieu existe
6. On devrait autoriser les municipalités à constituer des milices
7. Il faut soutenir le mouvement pour le Larzac
8. La force de frappe est indispensable
9. On peut avoir confiance en la justice
10. Les centrales nucléaires sont dangereuses
11. Il faut imposer fortement les gros propriétaires
12. Il faut supprimer la peine de mort
13. L'église exerce une influence néfaste
14. Il faut limiter les héritages
15. Il fallait construire le Concorde
16. Il faut censurer la pornographie
17. La limitation de vitesse devrait être supprimée
18. Les informations télévisées sont impartiales
19. La publicité rend service
20. Il faut réduire au maximum les écarts entre les salaires
21. La Police n'est pas au service du citoyen
22. Il y a trop de travailleurs immigrés en France
23. Il faut suivre la mode
24. Il faut limiter le pouvoir de PARIS au profit des régions
25. La France devrait supprimer son aide aux pays sous développés
26. La pollution n'est pas inquiétante
27. Avec le temps le progrès technique résout tous les problèmes
28. Les hyper-marchés rendent un grand service au consommateur
29. Les étudiants vivent en parasites de la société
30. Les pays du tiers monde deviennent trop puissants
31. Il faut chercher à travailler le moins possible
32. On doit tout faire pour la jeunesse
33. Ce n'est plus la peine de se marier
34. Il faut encourager la natalité
35. La science nous apporte plus de mal que de bien
36. La famille doit rester la cellule de base de la société
37. Les soldats devraient pouvoir constituer des syndicats
38. Il y a trop de dépenses de prestige en France
39. Le gouvernement ne fait pas assez pour lutter contre le chômage
40. La prostitution doit être réprimée sévèrement
41. Il faut tout faire pour maintenir la croissance économique
42. En France, il suffirait d'avoir une armée de métier
43. Si les conditions de sécurité sont insuffisantes dans une entreprise, il faut inculper le chef d'entreprise
44. On ne devrait plus exercer de responsabilités après 60 ou 65 ans
45. Les très grosses entreprises doivent être nationalisées
46. Il faut respecter les convenances
47. On devrait arrêter les importations de pétrole en provenance des pays arabes
48. Le mouvement de libération des femmes (M.L.F.) mérite d'être soutenu
49. Il est nécessaire de censurer certains films ou certains écrits
50. Les gens qui se suicident sont des faibles

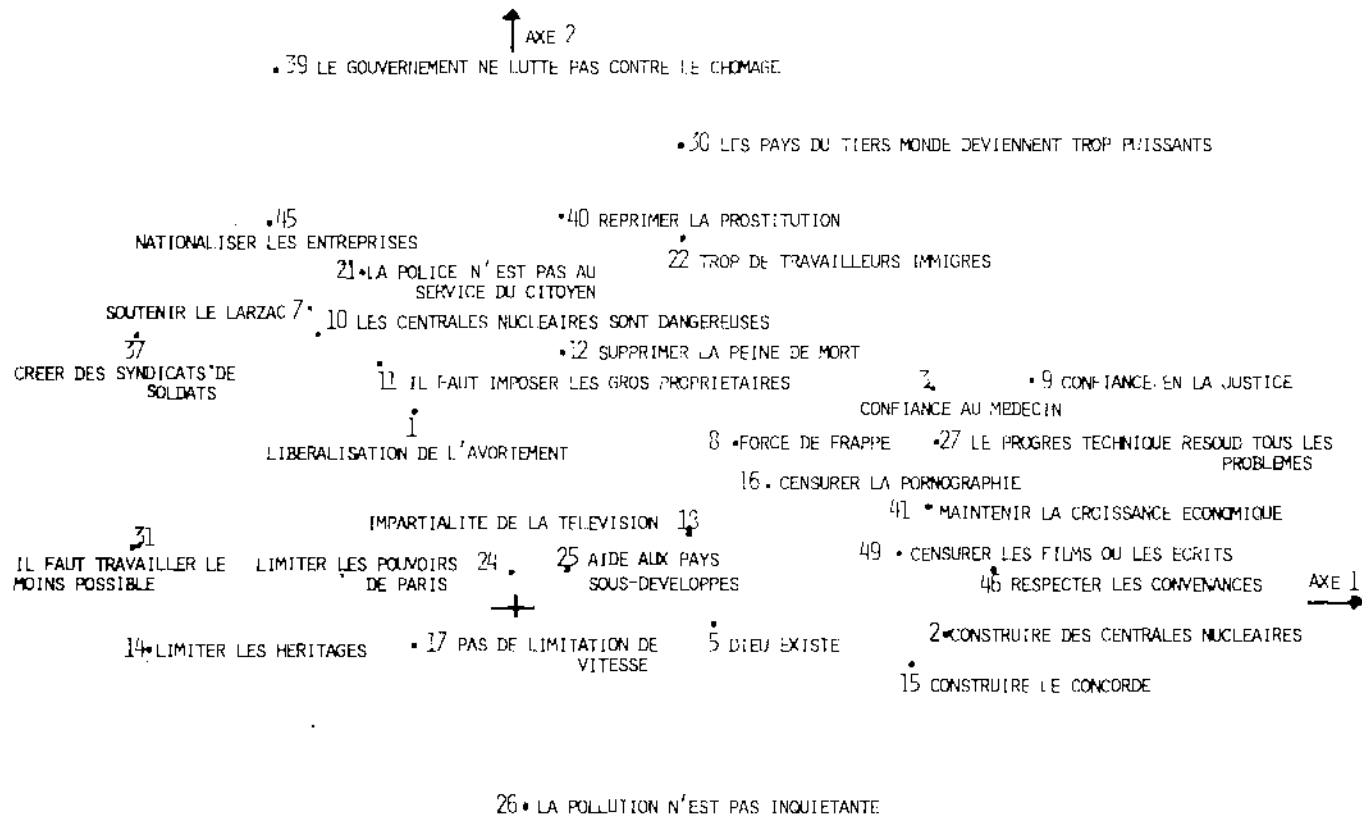

GRAPHIQUE 1 : EXTRAIT DES RESULTATS DE L'ANALYSE FACTORIELLE

IMPROVEMENTS IN DEPOSITION MODELS FOR ESTIMATING DOSE DISTRIBUTION FROM  
INHALED AEROSOLS

R.F. PHALEN, O.C. RAABE\*, K.A. BELL\*\* AND T.B. MARTONEN  
University of California, Irvine, California  
University of California, Davis, California\*  
Rancho Los Amigos Hospital, Downey, California\*\*  
U.S.A.

## 1. INTRODUCTION

In 1966, the Task Group on Lung Dynamics (ICRP) described improved deposition and clearance models for predicting aerosol dose to the human respiratory system (1). Deposition calculations, based on Findeisen's (2) anatomical model containing only five orders of bifurcation in the tracheobronchial tree, were applied to generalized nasopharyngeal (NP), tracheobronchial (TB) and pulmonary (P) compartments. Predicted total and compartmental deposition for various sized particles were in satisfactory agreement with existing experimental data. Recently, Mercer (3) evaluated the ICRP model in light of new experimental information. The Task Group computations apparently underestimate deposition in the TB compartment due to the paucity of bifurcations in the Findeisen anatomy; as a result, the ICRP model probably overestimates deposition in the critical P compartment. In any event, the ICRP model is limited to compartments and cannot be applied to predict dose distribution within a compartment. The much more realistic tracheobronchial airway anatomy of Weibel (4) was later used by Taulbee and Yu (5) in a refined mathematical model which incorporated some of Beeckman's (6) deposition equations. The use of Weibel's anatomical data allows generation by generation estimates of deposition, though Taulbee and Yu's original paper did not include such information.

The use of dose to a compartment, or even within a given airway, to evaluate hazard underestimates the dose to some tissues while it overestimates that to others. The following sections describe three anatomical factors that presumably produce a more uneven distribution of dose from inhaled aerosols than is predicted by the above models. These factors are: 1) differences in size and airway morphology of various lobes of the lung, 2) systematic changes in the geometrical shapes of airways at various levels within a given lobe, and 3) bronchial bifurcations which produce deposition maxima or "hot spots".

## 2. NON-UNIFORMITY OF DOSE RELATED TO ANATOMICAL DIFFERENCES AMONG LOBES

Although some still believe that the dose to lung tissue calculated for small radioactive particles must consider the microdose regions around each particle, it has been generally demonstrated that smear-dose calculations for lung tissue are conservative and realistic for estimating the radiological potential for many biological effects. Thus, it is not necessary to consider each particle as an individual radioactive source for hazard assessment even in the case of alpha-emitting particles.

Improved lung models of dose should consider the variations of dose that occur among lung lobes because of consistent differences in relative efficiency of particle deposition. This has been demonstrated by Raabe, et al. (7) in aerosol deposition studies in experimental animals for which anatomical information was available. Hamsters and rats were exposed to radio-labeled monodisperse aerosols of fused silicate spheres. The deposited

activity per unit lung weight was determined for each lobe and compared to the average for the whole lung. In both species the right apical lobe (corresponding to the right upper lobe of the human lung) had an activity concentration varying from 5 to 60% higher than the average for the whole lung. The higher concentration was more pronounced for larger particle sizes (Table 1).

In addition, Raabe, et al. showed that differences in relative lobar deposition were related to the geometric mean number of airway bifurcations between the trachea and terminal bronchioles in each lobe. Those lobes with the highest relative concentration of deposited particles were shown to have the least bifurcations and the shortest average path lengths of airways between the trachea and terminal bronchioles. For rats the ratio of the mean concentration for all particle sizes studied among lobes was roughly equal to the reciprocal of the square root of the mean path lengths from the trachea to the terminal bronchioles for the lobes.

If this same relationship holds for human lungs, the right upper lobe should receive from 50% to 75% higher deposition of radioactive particles than any other lobe. A greater disproportioning of dose would be expected for larger particle sizes. Dose calculations for inhaled radioactive particles deposited in the human lung should therefore give proper consideration to this non-uniformity of dose among the lung lobes.

Lobe	Aerodynamic Diameter, Micrometers					
	3.05	2.09	1.04	0.52	0.2	Mean
R.A.	1.21	1.32	1.12	1.05	1.10	1.15
R.C.	0.93	0.95	1.00	1.02	0.97	0.98
R.D.	0.84	0.99	0.96	0.89	0.93	0.92
R.L.	0.75	0.88	0.95	1.02	1.06	0.94
Left lung	1.21	0.97	1.01	1.06	1.01	1.05
Mean	0.99	1.02	1.01	1.01	1.02	1.01
S.D.	0.11	0.09	0.03	0.03	0.03	0.05

TABLE 1. Relative Lobar Concentration of Inhaled Particles in Rats (Percent of Total Lung Burden/Percent of Total Lung Weight)

### 3. VARIATIONS IN STRUCTURE WITHIN A LOBE

Deposition models that do not include realistic shapes of bifurcations at various levels (divisions down) in the tracheobronchial tree may not reproduce the dose pattern within a lobe. The noted morphometric data mentioned have shown that the assumptions of constant branching angle, asymmetry ratio (in daughter diameter) or length to diameter ratio throughout a lobe are invalid. The systematic variation in these parameters is shown in Figure 1. Branch angles increase for smaller airways, especially for those with diameters below 4 mm. A maximum asymmetry of about 1.5 in daughter diameter ratios occurs for bronchi of about 2 mm in diameter. The length to diameter ratio has its maximum value of about 3 for airways slightly less than 2 mm in size. Though the net effect of these factors has not been ascertained, it appears that in any model having symmetry in branching angles impactational deposition is likely to be underestimated in the smaller airways within the TB compartment and overestimated in the larger ones. This follows from the observation that branch angles increase rapidly for small airways.

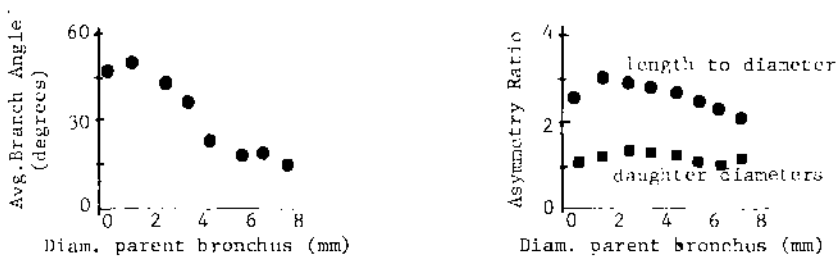

FIGURE 1. Human airway morphology as a function of parent bronchus diameter

#### 4. INFLUENCE OF BIFURCATIONS ON LOCAL DEPOSITION

A major factor leading to uneven deposition in the respiratory tract is the complex geometry, air flow and particle transport behavior at bifurcations. Local deposition maxima or "hot spots" have been observed at lung bifurcations by Nadel, et al. (8). Bell, and Bell and Friedlander (9,10) have quantitated "hot spots" in theoretical and experimental studies using spherical particles in models of a single human airway bifurcation.

Figure 2 shows the deposition pattern for 0.365  $\mu\text{m}$  particles measured by Bell (9) in the daughter branch of his bifurcation model. The peak "hot spot" occurs at the carina of the bifurcation within contour A. It has a transfer coefficient 3.4 times larger than the average value over the branch and its surface area is only 0.6% of the total or 11  $\text{mm}^2$ . The approximately 150,000 epithelial lining cells in this area at the first bifurcation in a human lung should receive at least 3.4 times more particles than predicted from uniform deposition.

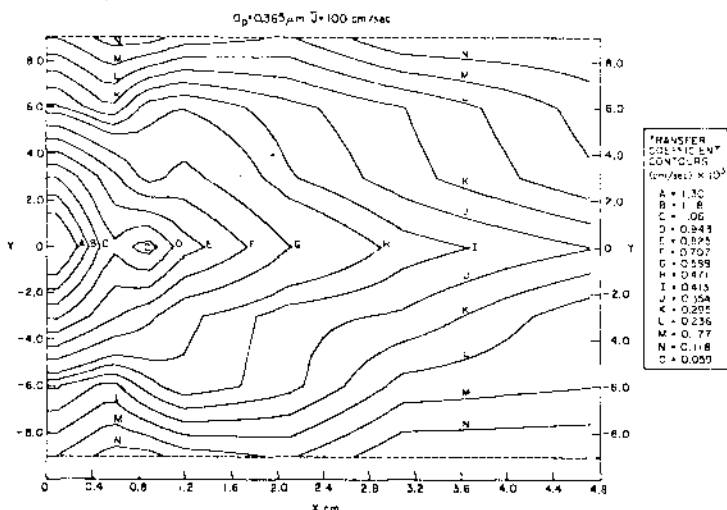

FIGURE 2. Deposition pattern for 0.365  $\mu\text{m}$  particles where  $k_{AV} = 3.83 \times 10^{-4}$  (9)

By normalizing the transfer coefficient in this small carinal area by the average transfer coefficient over the entire branch surface, a "hot spot" intensity or degree of nonuniformity of deposition is obtained. It varied from a high of 25.4 for  $d_p = 5.7 \mu\text{m}$  and  $\bar{U} = 200 \text{ cm/sec}$  to a low of 3.75 for  $d_p = 1.7 \mu\text{m}$  and  $\bar{U} = 100 \text{ cm/sec}$  where  $d_p$  is particle aerodynamic diameter and  $\bar{U}$  is the average flow velocity in the parent branch.

#### 5. SUMMARY

The effects mentioned above all tend to increase the non-uniformity of dose in the respiratory tract. The estimation of hazard based on average dose to the respiratory tract, or a compartment within it, may be seriously oversimplified by the use of even the best existing deposition models. Whether a more uneven dose results in a greater or lesser hazard is a matter of recent controversy and may be strongly dependent on the properties of the specific inhaled aerosol. Solution of this issue will require parallel efforts in theoretical modelling and laboratory studies in living animals.

#### REFERENCES

- (1) Task Group on Lung Dynamics. *Health Physics* 12 (1966) 173
- (2) FLINDEISEN, W., *Pfluger Arch. f.d. ges. Physiol.*, 236 (1935) 367
- (3) MERCER, T.T., *Health Physics* 29 (1975) 673
- (4) WEIBEL, E.R., *Morphometry of Human Lungs*, Springer-Verlag, Berlin (1975)
- (5) TAULBEE, D.B., and YU, C.P., *J. Appl. Physiol.* 38 1 (1975) 77
- (6) BEECKMANS, J.M., *Can. J. Physiol. Pharmacol.* 43 (1965) 157
- (7) RAABE, O.C., YEH, H.C., NEWTON, G.J., PHALEN, R.F. and VELASQUEZ, D.J., "Deposition of inhaled monodisperse aerosols in small rodents", *Inhaled Particles IV*, Pergamon Press (in press) 1977
- (8) NADEL, J.A., et al. *New Eng. J. Med.* 283 (1970) 281
- (9) BELL, K.A., "Aerosol Deposition in Models of a Human Lung Bifurcation", Ph.D. Thesis, California Institute of Technology, Pasadena, 1974
- (10) BELL, K.A. and FRIEDLANDER, S.K., *Staub-Reinhalt. Luft* 33 (1973) 178

A COMPREHENSIVE MODEL FOR RETENTION OF EXOTIC NUCLIDES

KAZUAKI KATOH\* AND JUNKO MATSUBARA\*\*

\* National Laboratory for High Energy Physics,  
Tsukuba JAPAN

\*\* The University of Tokyo School of Medicine,  
Tokyo JAPAN

1. INTRODUCTION

Internal contamination problems are usually treated with the compartment model and the behavior of the exotic nuclide taken into the body is expressed with the retention function  $r(t)$  as

$$q(t) = \int_0^t x(t') r(t - t') dt' \dots \dots \dots (1)$$

where  $x(t)$  : rate of intake, and  
 $q(t)$  : amount of the quantity existing in the compartment

It is clear from the definition of the retention function that the function  $r(t)$  must satisfy the condition  $r(t=0)=1$  and for any functional form of  $x(t)$  the right hand side of Eq.(1) must be convergent.

The exponential function model (EFM) was introduced rather theoretically on the assumption that the rate of excretion is proportional to the amount of the radionuclide in the compartment. The retention function is given as

$$r(t) = e^{-\lambda t} \dots \dots \dots (2)$$

which is a solution of the differential equation

$$- \dot{r}(t) / r(t) = \lambda, \quad \dot{r} \equiv dr/dt \dots \dots \dots (3)$$

While the following power function model (PFM) was introduced eventually in ICRP Reports,

$$r(t) = A t^{-b} \dots \dots \dots (4)$$

which is a solution of the equation,

$$- \dot{r}(t) / r(t) = b/t \dots \dots \dots (5)$$

It is usually believed that any simple power function can be written as the sum of properly chosen exponential function<sup>4</sup>, but from comparison of Eq. (3) and Eq. (5) it is clear that the believe is not correct. The EFM of Eq. (2) satisfies the above said conditions while the PFM of Eq. (4) satisfies none of them. In order to get rid of these difficulties, ICRP recommends some trials of modification<sup>2,3</sup> which seems to be nothing but petty tricks.

ICRP Pub. 20 gives a six parameter model,

$$r(t) = (1-p)e^{-\lambda t} + p e^{b(t+\epsilon)^{-b}} [\rho e^{-r\lambda t} + (1-\rho)e^{-\sigma r\lambda t} \dots (6)$$



which was constructed with a lot of physiological discussions but seems to have too many parameters in practice to describe general dynamics of such a metal retention in organisms. Better model having fewer parameters with wide applicability for the internal dosimetry is to be presented.

## 2. A New Model

A unification of the currently used EFM and PFM in a simplest manner can be made with a retention function of

$$r(t) = (1+at)^{-\lambda/a} \dots\dots\dots (7)$$

where  $a$  and  $\lambda$  are constants. Induction of EFM can be easily seen as follows.

For  $at \gg 1$  Eq. (7) approaches  $(a^{-\lambda/a}) (t^{-\lambda/a}) = At^{-b} \dots (8)$

at  $\ll 1$  Eq. (7) approaches  $\lim_{at \rightarrow 0} (1+at)^{-\lambda/a} = e^{-\lambda t} \dots (9)$

So the model is a unification of the currently used exponential and power function models. This model thus seems to describe underlying mechanism of conventionally utilized two models. Moreover it has no difficulty of the divergence at time  $t=0$ , which is the fatal defect of the power function model.

The amount (or concentration) of the nuclide in organ under observation is given as follows corresponding to Eq. (7),

$$q(t) = q_0 (1+at)^{-\lambda/a} \dots\dots\dots (10)$$

where  $q_0$  is the amount (or concentration) of the nuclide at  $t=0$ . Eq. (10) is a solution of the following equation,

$$-\dot{q}(t)/q(t) = \lambda / (1+at) \dots\dots\dots (11)$$

## 3. Cofitting to the Experimental Data

One of the authors (J.M.) has studied retention of  $Cd^{109}$ ,  $Hg^{203}$ ,  $Zn^{65}$ ,  $Cr^{51}$ , and  $Se^{75}$  in various organs of the mouse after the single injection of each radionuclide. The obtained data were previously tried to fit the one of the following

function as (1)  $y = A e^{-Bt}$ , (2)  $y = \sum_{i=1}^n A_i e^{-B_i t}$  or

(3)  $y = A (e^{-Bt} - e^{-Ct}) / (C - B)$ , where  $y$  is the concentration of nuclide in organ and  $A, B$ , etc are constants<sup>5,6</sup>.

Among those, data fitted to Eq. (2) i.e. sums of the exponentials, were reprocessed to fit the present retention function (7) with least squares method using HITAC 8800.

The whole body retention of  $Cd^{109}$  and majorities of organ retention of  $Zn^{65}$  and  $Se^{75}$  showed good fitness. The obtained parameters of fitted function (7) are listed in Table 1. Fig. 1 shows an example to compare the degree of fitness to the conventional exponential model with the present model.

#### 4. Check of the Validity of the Model

Already lots of data have been reported dealing with organ retention of various radionuclides after single administration to animals. It was tried to compare AIC values\* of our retention model with those of conventional models using the data already published by various authors. Fig.2 shows one example of model fitting to organ retention of Zn65 reported by J.F.Ballou et al. Our model fitted well for these data as shown with dotted line in Fig.2. The data of whole body retention by E. Lloyd were also utilized for similar discussion. Calculated AICs from both models were compared as presented in Table 2. Generally speaking, whole body data fitted our model better than the summation of exponential functions, while some organs showed better fitness to the conventional ones.

\* AIC =  $-2 \ln(\text{maximum likelihood}) + 2(\text{number of parameter})$

#### 5. Conclusion

A mathematical model to describe the retention of radionuclides in organs or in the whole body is proposed. The expression is in a unified form of the conventional exponential function and power function and well-behaved mathematically, having no defect of divergence at  $t = 0$ .

The validity of the model was demonstrated by cofitting the data obtained from retention studies of various nuclides in mouse organs to the new model and was diagnosed as minimum AIC estimate (MAICE).

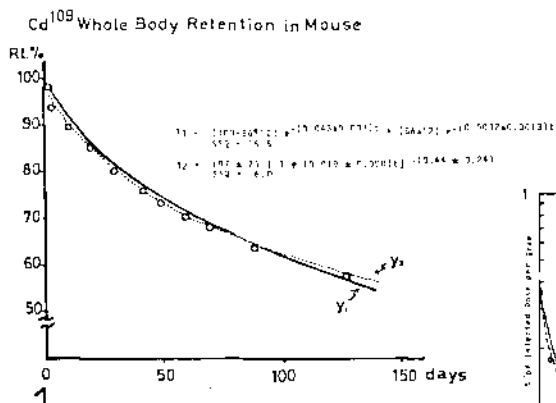

Fig. 1 Comparison of the fitness of the exponential model( $y_1$ ) to that of the present model( $y_2$ ).

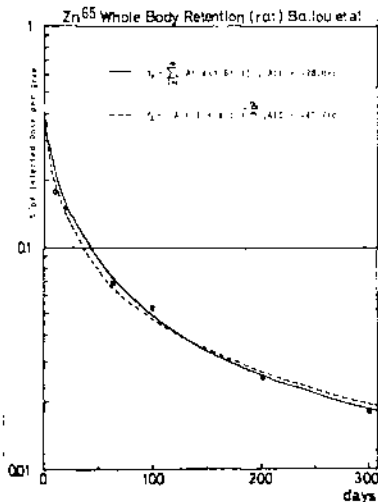

Fig.2 Comparison of the fitness of the two models and calculated AICs.

**Table 1A :** List of the obtained parameters of new model fitted to experimental data by authors'. ( ICR mouse 6 )

organs	Zn65		Sc75		Cr51		Gd109	
	a	$\lambda$	a	$\lambda$	a	$\lambda$	a	$\lambda$
kidney	0.175	0.292	-	-	-	-	-	-
liver	0.151	0.236	-	-	-	-	-	-
pancreas	0.118	0.205	0.065	0.190	-	-	-	-
spleen	0.121	0.190	0.293	0.320	-	-	-	-
stomach	0.046	0.056	0.092	0.206	-	-	-	-
lung	0.071	0.187	0.083	0.198	0.379	0.397	-	-
muscle	0.022	0.058	0.066	0.101	21.0	8.06	-	-
skeleton	1.26	0.282	0.326	0.355	-	-	0.036	0.026
brain	-	-	-	-	4.51	1.24	-	-
gonad	0.013	0.064	0.091	0.234	-	-	-	-
saliivary gland	0.064	0.114	-	-	1.83	0.57	16.0	4.64

**Table 1B:** List of the obtained parameters of new model fitted to the data already published.

nuclide	animal	organ	a	$\lambda$	$\lambda/a$	$\lambda/\lambda$	Ref.
Pu-239	man	blood	0.47	0.15	1.91	0.22	W.H. Langham H.P.2'59
Pu-239	man	W. body	0.041	0.032	0.024	0.0042	"
Pu-239	rat	muscle	0.029	0.029	0.24	0.15	J.C. Nenot et al.
Pu-238	rat	muscle	0.063	0.038	1.84	0.59	H.P. 22 '72
Np-237	rat	muscle	0.97	0.02	0.31	0.16	"
Cm-242	rat	muscle	0.65	0.58	0.30	0.08	"
Pu-238	rat	lung	0.20	0.15	0.36	0.13	"
Pu-239	rat	lung	0.13	0.10	0.65	0.24	"
Am-241	rat	lung	0.18	0.025	1.19	0.062	"
Cm-242	rat	lung	0.082	0.022	2.05	0.32	"
W-181	beagle	lung	52.1	10.0	0.502	0.013	R.L. Ammodt H.P.28'75

**Table 2** Comparison of AIC of present model with conventional model

(1) Retention function of Zn65 in rat by Ballou et al  
 whole body  $Y_1 = 0.15e^{-0.116t} + 0.15e^{-0.024t} + 0.049e^{-0.0033t}$   
 $AIC = -28.0 + c$   
 $Y_2 = 0.409 \left( \frac{1}{1 + 0.128 t} \right) - 0.823$   
 $AIC = -40.7 + c$

(2) Retention function of Ca45 in rabbit by Lloyd  
 whole body  $Y_1 = 71.0e^{-0.462t} + 7.7e^{-0.064t} + 21.3e^{-0.0051t}$   
 $AIC = -64.7 + c$   
 $Y_2 = 77.3 \left( \frac{1}{1 + 1.06 t} \right)^{-1.47} + 22.2e^{-0.0057t}$   
 $AIC = -91.6 + c$

**REFERENCES**

- 1) ICRP Publication 10 (1968)
- 2) ICRP Publication 10A (1971)
- 3) ICRP Publication 20 (1973)
- 4) Fitzgerald, J.J., G.L. Brownell and F.J. Mahoney : Mathematical Theory of Radiation Dosimetry, Gordon and Breach, New York London Paris (1967)
- 5) Matsubara-Khan, J.: Environmental Research, 7, pp54 - 67 (1974)
- 6) Matsubara-Khan, J. and K. Sei : Proc. 1st World-Congr. Nucl. Med. Tokyo, 1211-1213 (1974)
- 7) Akaike, H.: IEEE Trans. Automat. Contr. AC-19, pp716-723 (1974)
- 8) Ballou, J.E. and R.C. Thompson : Health Physics, 6, pp6-18 (1961)
- 9) Lloyd, E. : Assessment of Radioactivity in Man Vol.1, p329 IAEA (1964)

FACTORS WHICH ALTER THE PARAMETERS FOR EVALUATING INTERNAL EXPOSURE

JUNKO MATSUBARA AND KAZUHO MAEDA

The University of Tokyo, School of Medicine

As a fundamental of dose evaluation of internal exposure, it is necessary to check the factors which alter the dynamics of metal turnover. In the process of mathematical adjustment of the data obtained from retention survey after single exposure of various radionuclides to mice, it was noted that some data showed systematic deviations, from others according to a certain biological or chemical factors. The present report was summarized discussing our experimental results to check the said factors.

1. Methods

Mice were given single injections of radionuclide such as cadmium-109 or zinc-65. The animals were sacrificed at serial time intervals and dissected into more than ten organs. Each organ was radioassayed with scintillation counter. Thus obtained data of organ retentions of a nuclide were processed to fit varieties of mathematical models as described in other reports.<sup>1), 2)</sup> Besides, organ concentrations of stable Cd and Zn were followed by atomic absorption spectroscopy of the ashed samples obtained from varied age of mice.

2. Results and Discussion

2.1 Sex

Our data of the whole-body retention of Cd-109 in males and females showed clear sexual difference between them. With exponential model such as  $Y = \sum B_i \exp(-B_i t)$  females gave smaller rate constant  $B_i$  than males e.g. in males  $B_3 = 0.0032$  (day<sup>-1</sup>), in females  $B_3 = 0.0020$ . While applying to our new retention model<sup>2)</sup>  $y = q_0 (1+at)^{-\frac{a}{\lambda}}$ , sexual variation was demonstrated more explicitly with  $a$ , which we defined as deposition coefficient but not with  $\lambda$ , i.e. rate constant as shown in Fig. 1.

It was also tried to process the data from other workers e.g. the whole-body retention of Am-241 in male and female rats by Durakovic et al.<sup>3)</sup>, though it was failed to show the said sexual difference of  $a$ , due to the difficulty of obtaining the converged values from the scattered data.

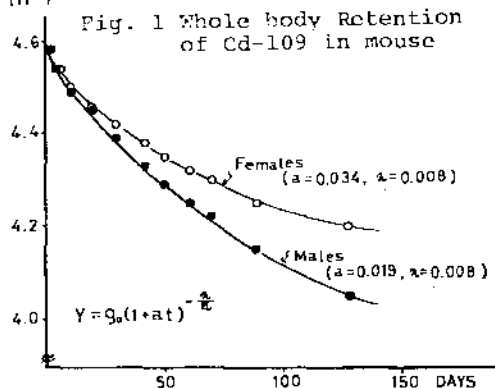

### 2.2 Age

FIG. 2A and 2B shows the long range drifts of concentration of stable cadmium and zinc in various organs of the mouse. Comparing the concentration levels of both elements, they showed somewhat similar relative distributions. While in a long range their dynamics seemed to be quite different. Previously it was also confirmed with repeated retention surveys that the turnover speeds of both radionuclides were quite different as seen in FIG. 3A and 3B.

Correlation coefficients between Cd and Zn data obtained with similar experimental conditions were calculated and listed on TABLE 1.

This shows metabolic speeds of both elements in organisms are strikingly different each other in spite of their similarity of chemical nature.

Fig. 2 Long Range Drifts of Organ Concentrations of Stable Zn(A)

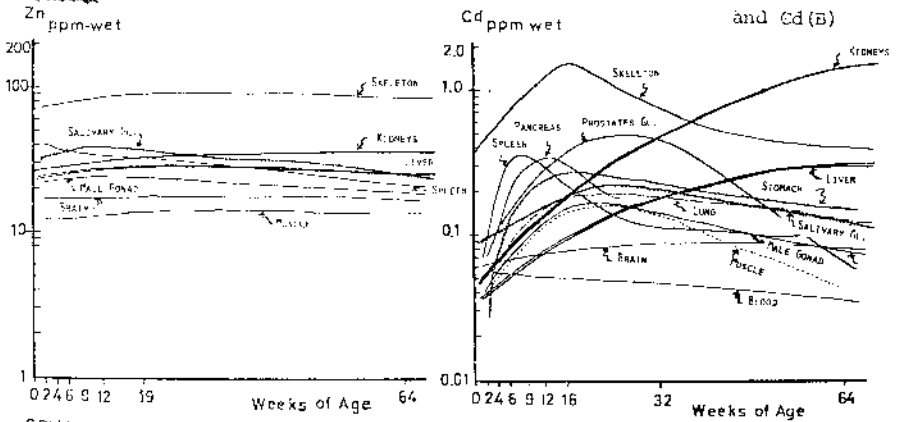
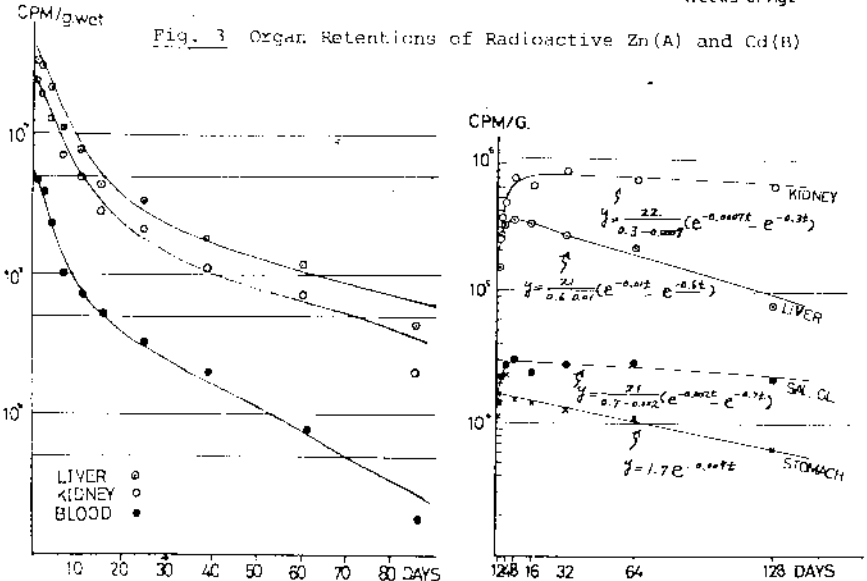

Fig. 3 Organ Retentions of Radioactive Zn(A) and Cd(B)



Usually compartment model is applied for the steady state kinetics. In case of cadmium, the concentration increases even at adult ages as can be noticed on Fig. 2B. Taking into accounts of these facts, it must be established peculiar model for growing animals, i.e. model for non-steady state where metal concentration is shifting according to age.

Vanderploeg et al. gave a note on the explanation of compartment models applied to the system not in a steady state and deduced that the rate constant derived from long experiment of radionuclide concentration (cpm/g) is  $(\beta + W/W)$  where  $\beta$  is the rate constant obtained from the retention of total amounts of radionuclide in a organ,  $W$  is the weight of organ under the observation and  $\dot{W}$  stands for  $dW / dt$ . The present authors confirmed the above by performing Cd-109 retention survey of growing mouse from 4 weeks until 33 weeks of age. (See Table 2)

### 3. Levels of the Coexisting Stable Isotope

Single injections of Cd-109 were performed with and without the additions of stable cadmium 0.75  $\mu\text{g/g}$  mouse. Retention of radioactive Cd in kidneys was higher by two fold in no carrier added group, while completely vice versa in the liver (See Fig. 4). This type of opposite reaction of radioactive Cd in the liver to kidneys was confirmed repeatedly. Fig. 5 shows our schema of cadmium distribution and turnover in mouse of both experimental groups, where 70 - 80 % of whole body dose distributes in the liver and kidneys. In the liver the concentration (cpm/g) of Cd-109 is higher in carrier added group. It was speculated that liver can concentrate metal as much as possible where a certain carrier protein must be induced by the addition of metals, though the all amounts can not be transferred to kidneys due to lack of enough carrier. There must exist completely different isotope mixing mechanism between the liver and kidneys. Further experimental studies are necessary to clarify these speculation.

Table 1

1. Correlation of concentrations of Cd and Zn in various organs in the same samples analysed by atomic absorption spectroscopy  
Correlation coefficient,  $r = 0.348$  ( $n=21$ , 64 W old)  
 $r = 0.887$  ( $n=11$ , 7 W old)
2. Correlation between the concentrations of nuclide obtained from tracer experiment and chemical analysis of atomic absorption spectroscopy  
Cd :  $r = -0.10$  ( $n=11$ , less than 16W old)  
 $r = 0.76$        $0.83$  ( $n=11$ , more than 19W old)  
Zn :  $r = 0.84$        $0.92$  ( $n=11$ , 6 - 24 W old)
3. Correlation of rate constants of Cd and Zn in various organs ( Comparison of turnover character )  
 $r = -0.037$  ( $n=11$ , 8 - 25 W old)

**Table 2 :** Comparison of rate constants observed RI concentrations (cpm/g) with those from RI amounts (cpm) plus W/W. (Experiments with growing mice)

post-adm. days	weight of organ	W/W	$\beta'$ from cpm/g data	$\beta$ from cpm data plus W/W
2	1.50	0.029	0.038	0.041
4	1.58	0.022	0.033	0.034
8	1.91	0.010	0.030	0.022
25	2.09	0.006	0.026	0.018
35	2.19	0.003	0.021	0.015
50	2.27	0.0015	0.014	0.014
64	2.30	0.0009	0.010	0.013
99	2.33	0.0000	0.010	0.012
123	2.33	0.0000	0.010	0.012
171	2.25	-0.0013	0.010	0.011
202	2.16	-0.0019	0.010	0.010

**Fig. 4 A** Retention of Cd-109 in liver and kidneys with and without addition of stable cadmium to adult mice.

**Fig. 4 B** The same but in growing mice.

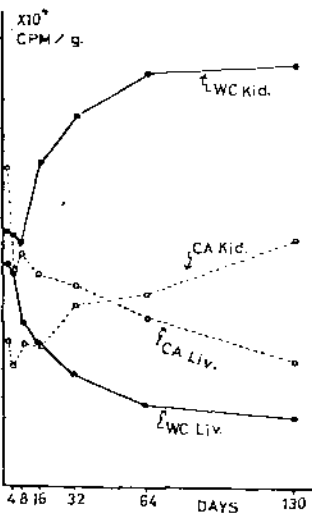
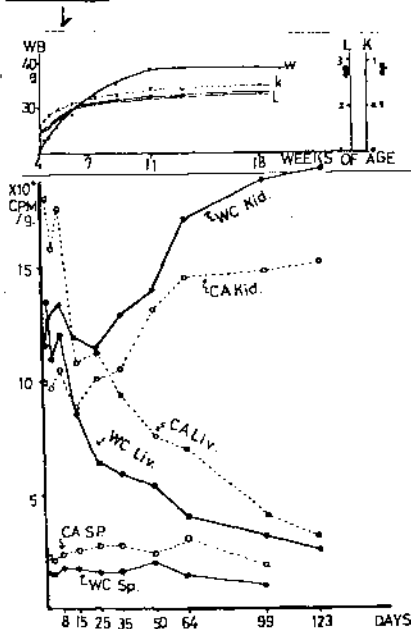

**Fig. 5** Schema on the turnover of Cd-109 in the liver and kidneys in no carrier added (upper) and carrier added animals (below).

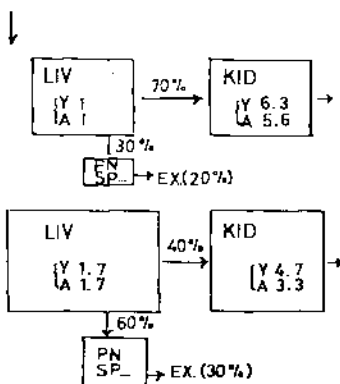

**REFERENCES**

- 1) Matsubara-Khan, J. : Environmental Research, 7, pp54 - 67(1974)
- 2) Katoh, K. and J. Matsubara, presented in this issue, IRPA 1977
- 3) Durakovic, A.B., J.G. Hollins and M.G. Starr: Health Physics, 24, pp541-546 (1973)
- 4) vanderploeg, H.A. and R.S. Booth : Health Physics, 31, pp57-59 (1976)

OBSERVATION DIRECTE DU DEPOT DES AEROSOLS  
MARQUES DANS L'ARBRE RESPIRATOIRE DU RAT

Ph. DUPORT, Commissariat à l'Energie Atomique, Département de Protection, Section Technique d'Etudes de Pollution dans l'Atmosphère et dans les Mines, BP n° 6, 92260 Fontenay aux Roses, France

C. PEYRAUD, A. RENOUX, Faculté des Sciences, U.E.R. Sciences de Brest, Avenue Victor Le Gorgeu, 29900 Brest, France

## 1. INTRODUCTION

On décrit une méthode d'observation directe du dépôt d'aérosols marqués dans l'arbre respiratoire du rat.

On compare les résultats expérimentaux obtenus à un dépôt théorique que l'on peut calculer à partir d'un modèle établi par le Task Group on Lung Dynamics (TGLD) (1).

## 2. ETUDE EXPERIMENTALE DU DEPOT DES AEROSOLS MARQUES DANS L'ARBRE RESPIRATOIRE DU RAT

### 2.1. Dispositif expérimental

On place le rat dans une enceinte de 50 dm<sup>3</sup> (fig. 1), elle-même située dans un circuit comportant une source de radon, avec un dispositif qui permet, soit l'arrivée directe du radon, soit l'arrivée du radon filtré, avec la possibilité d'injecter de la fumée de tabac dans l'enceinte. Une pompe et un débitmètre permettent éventuellement d'ajuster le débit, donc l'équilibre radioactif, dans l'enceinte.

### 2.2. Détection des descendants du radon

On a mis au point (2) une technique d'autoradiographie (Fig.2) utilisant un film de nitrate de cellulose KODAK, type II, d'épaisseur utile 13 µm.

On a montré (2) que dans nos conditions expérimentales seuls les  $\alpha$  du <sup>214</sup>Bi étaient enregistrés sous une incidence quasi normale si l'on intercalait un écran d'épaisseur appropriée entre le dépôt d'aérosol marqué et le détecteur.

Après son exposition au radon, le rat est sacrifié. Après la coupure des gros vaisseaux qui élimine une grande partie du sang de l'animal, son appareil respiratoire est prélevé, coupé en deux dans le sens longitudinal. Les deux demi-arbres respiratoires sont étalés sur l'écran couvrant le détecteur, puis pressés.

Après décroissance des descendants à vie courte du radon, le film est attaqué dans une solution chaude de NaOH, lavé et séché. Les



traces latentes apparaissent alors comme des "trous". Un tirage photographique du détecteur donne une réplique fine des traces alpha enregistrées. On peut alors mesurer l'intensité de l'irradiation par mesure optique de la densité de noir sur la réplique.

### 2.3. Conditions d'irradiation des rats

Par contrôle de l'empoussièrage et du temps de séjour du radon dans l'enceinte, on a déterminé trois situations distinctes :

- aérosol de rayon  $R = 0,5 \mu\text{m}$  (situation I)
- aérosol de radiolyse de  $R = 2.10^{-3} \mu\text{m}$  (situation II)
- aérosol de radiolyse de  $R = 5.10^{-4} \mu\text{m}$  (situation III).

dans les trois cas la concentration du radon est de  $3.10^{-5}$  Ci/l.

### 2.4. Résultats expérimentaux

Pour apprécier les rapports d'irradiation observés entre les trois cas expérimentaux, on a tenu compte de la concentration réelle des atomes radioactifs présents pour chacun d'eux.

D'après les mesures de densité de noir (Fig. 3), on dresse le tableau ci-dessous, qui résume les densités optiques lues, puis corrigées, pour chaque cas d'irradiation, dans les trois régions pulmonaires considérées, ainsi que pour le pourcentage théorique de l'aérosol retenu dans les situations I et II. Les pourcentages théoriques sont ceux que l'on calcule d'après les travaux du TGLD.

	situation I			situation II			situation III	
	D.O. lue	D.O. corrigée	% th	D.O. lue	D.O. corrigée	% th	D.O. lue	D.O. corrigée
N.P.	13	13	35	3	5	22	55	780
T.B.	230	230	2	20	28	35	100	1 400
P.	490	490	27	140	190	43	5	70
éperon bronchique							17	220

D.O. = densité optique du noircissement.

Les particules de la situation III sont trop petites pour qu'on puisse appliquer la répartition théorique du TGLD.

Nous avons assimilé la partie supérieure de l'arbre respiratoire à une batterie de diffusion cylindrique de 1 mm de rayon, et de 50 mm de long. Nous avons estimé, compte tenu des paramètres respiratoires du rat, que l'on pouvait appliquer les équations classiques de diffusion dans ce cas. De la sorte, 75 % des particules devraient être arrêtées à la hauteur de l'éperon bronchique.

On a estimé, en première approximation, que l'irradiation recueillie par le détecteur est proportionnelle à la masse des différentes parties de l'arbre respiratoire (2). Dans ces conditions, dans le cas de l'aérosol I, le poumon a retenu environ 40 fois plus de radioactivité que la trachée, ce résultat est voisin de ce que laisse prévoir le TGLD.

La pénétration de l'aérosol du cas II, bien qu'inférieure au cas I, est également importante dans le poumon profond. L'irradiation de la trachée est ici 4 à 6 fois inférieure à ce que l'on observe dans la situation I.

Dans ces deux derniers cas, la répartition de l'aérosol dans les voies respiratoires évolue dans le sens prédit par le TGLD.

L'examen du cas III semble intéressant. En effet, si l'on admet que la faible irradiation observée sur les lobes est due au radon dissout dans le sang (2), il reste une irradiation relativement très importante (voir tableau) dans la trachée. La densité de cette irradiation varie le long de la trachée comme laisse prévoir l'assimilation de ce segment à une batterie de diffusion. La densité optique corrigée est 2 à 3 fois supérieure à celle que l'on lit dans un lobe au cas I.

Ceci permet de penser que la captation de l'aérosol ultrafin (fraction libre) est totale, et qu'elle est localisée dans les voies aériennes supérieures et moyennes. L'irradiation des zones alvéolaires due à la fraction libre serait faible.

La répartition observée ici correspond bien aux résultats trouvés par CHAMBERLAIN et DYSON (3) sur un arbre trachéobronchique reconstitué.

### 3. CONCLUSION

Nous avons donc mis au point une technique nouvelle permettant l'examen direct du dépôt des aérosols radioactifs dans l'arbre respiratoire du rat. Mais il faut bien savoir qu'il ne s'agit là que d'une première étape. En particulier nous nous proposons d'améliorer notre processus expérimental. Par exemple, le mode de prélèvement et de préparation des organes devra être perfectionné, et c'est ainsi que la congélation immédiate des organes prélevés permettrait d'effectuer une coupe plus précise de l'arbre respiratoire, et d'éviter l'écoulement gênant des liquides biologiques.

Mais dès maintenant, nous avons pu constater que nos résultats sont en bon accord avec ceux obtenus par BARZIC (4) utilisant, dans la mine d'uranium expérimentale du CEA-STEPAM, un impacteur ANDERSEN, dont la succession des différents étages (7 ou 8 suivant les modèles), représente des segments de profondeur croissante des voies aériennes.

#### REFERENCES

- (1) Task Group on Lung Dynamics - I.C.R.P.  
Health Physics, 12, (2), 1966
- (2) Ph. DUPORT  
Thèse d'Université  
Brest 1976
- (3) A.C. CHAMBERLAIN, E.D. DYSON  
Br. J. Radiol., 29, 317, 1956
- (4) J.Y. BARZIC  
Thèse de 3ème cycle  
Brest 1975  
Rapport CEA-R-4743  
1976

## THE IN VIVO SOLUBILITY OF PLUTONIUM-239 PRODUCED IN PLUTONIUM-SODIUM AEROSOLS

G.N. Stradling, B.W. Loveless, G.J. Ham and H. Smith  
National Radiological Protection Board  
Harwell, Didcot, Oxon, England

## 1. INTRODUCTION

Fast Breeder reactors use liquid sodium as a coolant. Under certain accidental conditions there is a probability that mixtures of the oxides of plutonium and sodium (mixed oxides) could be released into the environment as a polydisperse aerosol. It has been shown previously that in rodents a significant fraction of the plutonium-239 (Pu) associated with these mixed oxides is readily transportable from the lungs to other body tissues (1,2,3). The objectives of this work are threefold. Firstly, to further characterise the transportable fraction; secondly, to evaluate the reactions that occur between this fraction and naturally occurring constituents of blood and urine; and thirdly, to investigate the relationship between the amount of Pu excreted in the urine and the body content in the early period after an intake.

## 2. MATERIALS AND METHODS

Mixed oxides were prepared as described previously (2,4). Two mixed oxides, with Pu to Na atomic ratios of 1:3 and 1:20 were used. These ratios were chosen because they have been shown to contain a small and a large transportable fraction of Pu respectively (1). The plutonium in these mixed oxides has the physico-chemical characteristics of plutonium-239 dioxide ( $\text{PuO}_2$ ) (1,4,5). Various particle size fractions between 0.001  $\mu\text{m}$  and 0.22  $\mu\text{m}$  were isolated by an ultrafiltration technique (4). Negligible amounts of plutonium were found in the nominal particle size range from 0.004 to 0.025  $\mu\text{m}$ . The amount of plutonium found in the 0.001  $\mu\text{m}$  diameter fraction varied with the Na content from 1.6% (atomic ratio 1:3) to 48% (atomic ratio 1:20). For comparison, the 0.001  $\mu\text{m}$  diameter fraction isolated from high temperature calcined  $\text{PuO}_2$  contained about 0.1% of the total Pu in suspension (4). The mixed oxides aerosol fractions were suspended in water and contained about  $1.4 \times 10^5$  spm  $\text{ml}^{-1}$ ; aliquots of this suspension were administered to rats either by pulmonary intubation (0.05 ml) or intravenous injection (0.2 ml). Plutonium citrate prepared as described previously (4) was used to provide control data on a known soluble form of Pu. The rats were young mature females, about 10 weeks old, weighing 150 g to 200 g, obtained from an inbred strain (Medical Research Council, Radiobiological Unit, Harwell). The animals were given food and water ad libitum. Radiochemical analysis for Pu and sampling and gel filtration separation techniques to determine the physico-chemical form of Pu in blood and urine were performed as described elsewhere (7).

## 3. RESULTS AND DISCUSSION

## 3.1 Transportability of mixed oxides

The enhanced transportability of Pu following the uptake of mixed oxides relative to  $\text{PuO}_2$  has been demonstrated in vivo (1,2,3). This could be due either to the presence of small particles of  $\text{PuO}_2$  or hexavalent or heptavalent Pu, all of which have been observed in vitro (1,2,6,7,8). Recent studies with  $\text{PuO}_2$  suggest that the transportability of Pu could be primarily dependent on the presence of small particles of  $\text{PuO}_2$  about 0.001  $\mu\text{m}$  in diameter (4). The tissue distribution and excretion pattern of Pu following the intubation of the 0.001  $\mu\text{m}$  particle fraction of mixed oxides is summarised in Table 1. The metabolic behaviour of Pu after 1 day is broadly similar to that observed after the pulmonary intubation of Pu citrate. About two-thirds of the Pu on the 0.001  $\mu\text{m}$  diameter fraction of the mixed oxides is behaving as a Class D compound according to the

classification of the Task Group Lung Clearance Model (9). However, after 21 days, Pu remaining in the lungs is behaving as a compound with long term retention. During the 21 day period the extra pulmonary tissue deposition of Pu is similar for the two mixed oxides and Pu citrate, e.g. the amounts of extrapulmonary Pu present in the skeleton (remaining carcass) is 35% and 36% (atomic ratios 1:3 and 1:20) for the mixed oxides and 36% for Pu citrate. The lung clearance and tissue distribution of Pu is independent of the Na content of the aerosol. It is postulated therefore that the primary effect of Na is to influence the particle size distribution of PuO<sub>2</sub> during the preparation of the aerosol and in particular the amount of the 0.001 μm fraction. Thus, when mixed oxides of Pu and Na contain appreciable quantities of 0.001 μm diameter PuO<sub>2</sub> particles the amount of Pu transferred to blood would be greater than that proposed in the Task Group Lung Clearance Model which considered PuO<sub>2</sub> as a Class Y (insoluble) compound (9). In contrast, there was negligible translocation (<0.5%) to extrapulmonary tissue of Pu associated with

Tissue/ Excreta	Period (days)	Plutonium administered as		
		Pu citrate	Mixed oxide suspension (0.001 μm diameter)	
			Pu:Na, 1:3 <sup>c</sup>	Pu:Na, 1:20 <sup>c</sup>
Lungs	1	28.2 ± 1.7	34.2 ± 1.2	32.2 ± 1.8
	6	7.40 ± 0.45	27.6 ± 2.4	25.0 ± 1.4
	21	5.43 ± 0.38	21.3 ± 0.9	18.0 ± 0.9
Liver	1	11.0 ± 1.0	8.37 ± 0.69	10.1 ± 1.1
	6	12.4 ± 0.4	7.67 ± 0.46	7.50 ± 0.52
	21	9.79 ± 0.33	6.30 ± 0.56	6.25 ± 0.22
Blood	1	3.07 ± 0.38	2.56 ± 0.26	3.53 ± 0.22
	6	0.32 ± 0.05	0.31 ± 0.04	0.19 ± 0.02
	21	0.06 ± 0.01	0.06 ± 0.01	0.09 ± 0.02
Other tissues <sup>a</sup>	1	1.69 ± 0.11	2.70 ± 0.20	2.58 ± 0.19
	6	3.20 ± 0.12	1.87 ± 0.15	2.12 ± 0.21
	21	1.63 ± 0.12	1.40 ± 0.12	1.42 ± 0.13
Remaining carcass	1	51.7 ± 2.6	42.5 ± 1.6	42.1 ± 1.2
	6	64.2 ± 0.6	44.1 ± 1.8	46.4 ± 0.6
	21	61.7 ± 0.7	46.3 ± 1.3	46.9 ± 0.7
Urine <sup>b</sup>	1	1.41 ± 0.14	6.80 ± 0.18	7.71 ± 0.22
	6	3.18 ± 0.22	8.33 ± 0.37	9.01 ± 0.21
	21	3.84 ± 0.21	10.7 ± 0.3	11.3 ± 0.2
Faeces <sup>b</sup>	1	2.93 ± 0.40	2.84 ± 0.28	1.78 ± 0.16
	6	9.40 ± 0.80	10.2 ± 0.7	9.85 ± 0.33
	21	14.6 ± 0.8	14.0 ± 0.3	16.0 ± 0.3

TABLE 1 Metabolic fate of plutonium administered to the rat by pulmonary intubation

Results, Mean ± SEM, expressed as % of initial lung content

Number of animals per group, 4

a kidneys, ovaries, adrenals, thymus, spleen and gastrointestinal tract

b cumulative excretion

c atomic ratio of Pu:Na in mixed oxide aerosol

mixed oxides particles between 0.025  $\mu$ m and 0.22  $\mu$ m diameter. After 21 days more than 94% of the Pu was present in the lungs.

### 3.2 The physico-chemical form of Pu in blood and urine

Monomeric Pu when injected into the blood is known to be complexed rapidly by the high molecular weight protein transferrin, and the low molecular weight anion citrate (10,11). The glomerular filtration of Pu citrate probably accounts for the presence of Pu in the urine. However, the data summarized in Table 1 shows that the urinary excretion of Pu is appreciably greater following the administration of 0.001  $\mu$ m diameter mixed oxides particles than after Pu citrate. This increase can be attributed principally to Pu excreted within the first 24 hours. Gel filtration studies showed that at early time intervals, a low molecular weight "intermediate" complex, thought to be a reaction product involving PuO<sub>2</sub> and the citrate anion, was circulating in blood and being filtered simultaneously through the kidneys. The clearance half time from blood was about three minutes (3). This species which has also been observed with high temperature calcined PuO<sub>2</sub> (4) probably explains the enhanced urinary excretion of Pu relative to administered Pu citrate. Ultimately Pu was found to be complexed by transferrin and citrate in blood and by citrate in urine.

### 3.3 The relationship between tissue deposit and urinary excretion

It has been suggested by Lafuma (12) that for a limited period of time following the inhalation of Pu compounds, a constant relationship exists between cumulative excretion of Pu and the amount translocated to tissue. This hypothesis is supported by data obtained following the intubation of Pu citrate and Pu nitrate into rats which showed that the systemic content of Pu after 1 week was about 25 times the amount appearing in urine (1).

Intubated material	U/T		
	0 - 1 days	0 - 6 days	1 - 6 days
Pu citrate (control)	47.8 $\pm$ 5.1	24.8 $\pm$ 1.8	114.6 $\pm$ 6.6
Mixed oxide (Pu:Na 1:3, 0.001 $\mu$ m)	8.3 $\pm$ 0.3	6.4 $\pm$ 0.4	34.6 $\pm$ 9.4
Mixed oxide (Pu:Na 1:20, 0.001 $\mu$ m)	7.6 $\pm$ 0.3	6.2 $\pm$ 0.3	43.0 $\pm$ 10.0

TABLE 2 Relationship between extrapulmonary tissue deposit (T) and cumulative urinary excretion (U) of plutonium

In contrast, the factors obtained following the intubation of the transportable fraction of oxide suspensions were lower and variable, viz. 18-20 for PuO<sub>2</sub>, 10-49 for mixed oxides (1). In the experiments with mixed oxides described here, the factor relating extrapulmonary tissue deposit and total urinary excretion is independent of the Na content of the suspension and about 4 times less than that for monomeric Pu after the first week (Table 2). Moreover these results are in agreement with the corresponding value obtained for PuO<sub>2</sub>, viz. 7.7  $\pm$  0.1 (4). It is therefore concluded that an empirical fixed factor cannot be arbitrarily assigned to the interpretation of urine analysis data although it would appear that when the enhanced excretion due to the "intermediate" is complete, i.e. essentially after the first day, the factor is reasonably independent of the physico-chemical form of the Pu intake (Table 2).

### 4. SUMMARY

The amount of plutonium transported from the lungs to blood in the early clearance phase following the intubation of mixed oxide suspension obtained from polydisperse aerosols depends primarily on the presence of plutonium dioxide particles of about 0.001  $\mu$ m diameter. When these particles are

present in significant quantity, the lung clearance characteristics are different from those defined for insoluble (class Y) compounds; the Task Group Lung Model would therefore require modification. Furthermore, the enhanced urinary excretion of plutonium relative to administered plutonium citrate invalidates the use of an empirical fixed factor to determine systemic burden.

#### 5. ACKNOWLEDGEMENTS

The authors are indebted to Mr. R. F. Carter, MOD Aldermaston, Berks., for the preparation of mixed oxide suspensions and Miss S.E. Breadmore for technical assistance. We thank Dr. G.W. Dolphin and Dr. J.W. Stather for critical reading of the manuscript.

#### REFERENCES

- (1) STATHER, J.W., HOWDEN, S. and CARTER, R.F., *Phys. Med. Biol.* 20 (1975) 106
- (2) BRIGHTWELL, J. and CARTER, R.F., IN *Proceedings of IV International Symposium on Inhaled Particles and Vapours*, Edinburgh (1975) (WALTON, W.H. Ed) Pergamon Press, Oxford (in press)
- (3) METIVIER, H., MASSE, R., NENOT, J.C., NOLIBÉ, D. and LAFUMA, J., IN "Diagnosis and Treatment of Interperated Radionuclides", IAEA Vienna, (1976) p.107
- (4) SMITH, H., STRADLING, G.N., LOVELESS, B.W. and HAM, G.J., submitted to *Health Phys.* (1976)
- (5) STRADLING, G.N., LOVELESS, B.W., HAM, G.J. and SMITH, H., submitted to *Health Phys.* (1977)
- (6) CHATFIELD, E.J., *J. Nucl. Mater.* 32 (1969) 228
- (7) CHATFIELD, E.J., *J. Nucl. Mater.* 32 (1969) 247
- (8) METIVIER, H., *Radioprotection* 2 (1974) 187
- (9) INTERNATIONAL COMMISSION ON RADIOLOGICAL PROTECTION, ICRP Publication 19, Pergamon Press, Oxford (1972)
- (10) POPPLEWELL, D.S. and BOOCOCK, G., IN "Diagnosis and Treatment of Deposited Radionuclides" (KORNBERG, H.A., NORWOOD, W.D., Eds) Excerpta Medica Foundation, Amsterdam (1968) p.45
- (11) POPPLEWELL, D.S., STRADLING, G.N. and HAM, G.J., *Radiat. Res.* 62 (1975) 513
- (12) LAFUMA, J., NENOT, J.C. and MORIN, M., IN "Assessment of Radioactive Contamination in Man", IAEA Vienna (1972) p.235

INFLUENCE DES CARACTÉRISTIQUES GRANULOMÉTRIQUES  
SUR L'ÉVOLUTION THÉORIQUE DES EXCRETIONS URINAIRE ET FÉCALE  
DU PLUTONIUM INHALÉ

B. MENCUX, P. SFAU, J.C. NENOT

Département de Protection  
Commissariat à l'Énergie Atomique - BP 6  
92260 FONTENAY AUX ROSES (France)

Les dernières recommandations de La CIPR tiennent compte de la granulométrie des particules inhalées pour l'évaluation des doses engagées des personnes contaminées.

L'influence de la granulométrie a été étudiée pour des aérosols de 0,2  $\mu\text{m}$ , 1  $\mu\text{m}$  et 10  $\mu\text{m}$  (exprimé en D<sub>AM</sub>, diamètre aérodynamique médian en masse) sur les courbes théoriques d'excrétion urinaire et fécale de  $^{239}\text{Pu}$ .

Le Plutonium a été considéré sous deux formes chimiques :

- $^{239}\text{Pu}(\text{O}_2)$ , appartenant à la classe Y
- $^{239}\text{Pu}(\text{NO}_3)_4$ , appartenant à la classe W du modèle de dépôt et d'épuration respiratoire proposé par le "Groupe de Travail sur la dynamique pulmonaire" de la CIPR (1).

### 1. EXCRETIONS URINAIRE ET FÉCALE THÉORIQUES

Pour une quantité unitaire inhalée, on a déterminé la quantité de  $^{239}\text{Pu}$  qui passe dans le sang en suivant la cinétique du radioélément selon le modèle respiratoire cité plus haut.

La quantité épurée par voie rénale est obtenue par convolution entre la quantité dans le sang et la fonction d'excrétion urinaire définie par Durbin (2).

Les quantités éliminées par les fèces comprennent :

- la quantité épurée par voie haute qui sécrète directement de la cinétique du radioélément dans les compartiments du modèle respiratoire et dans le tractus gastro-intestinal (3) ;
- la quantité épurée par voie biliaire obtenue par convolution entre la quantité de  $^{239}\text{Pu}$  dans le sang et la fonction d'excrétion fécale endogène de Durbin (2).

### 2. RESULTATS

Les variations des excrétions urinaire et fécale en fonction du temps et pour les trois granulométries de 0,2  $\mu\text{m}$ , 1  $\mu\text{m}$  et 10  $\mu\text{m}$ , sont données dans la figure 1 pour le  $^{239}\text{Pu}(\text{O}_2)$  et dans la figure 2 pour le  $^{239}\text{Pu}(\text{NO}_3)_4$ .



### 3. INTERPRETATION

On remarque que :

a) Les éliminations urinaire et fécale varient dans le même sens que la taille des particules inhalées pendant les 3 à 4 jours qui suivent l'inhalation pour l'excrétion fécale et les 10 premiers jours pour l'excrétion urinaire, la majeure partie des quantités excrétées provenant de l'épuration au niveau du naso-pharynx. Les quantités excrétées sont 2,2 fois plus grandes pour un aérosol de 10  $\mu\text{m}$  que pour un aérosol de 1  $\mu\text{m}$ , et elles sont environ 0,6 fois plus petites pour un aérosol de 0,2  $\mu\text{m}$  que pour un aérosol de 1  $\mu\text{m}$ .

b) Les éliminations urinaire et fécale varient en sens inverse de la taille des particules inhalées,  
- pour le  $^{239}\text{Pu}(\text{O}_2)_2$ , à partir du 15<sup>ème</sup> jour après inhalation, pour l'excrétion fécale et du 120<sup>ème</sup> jour pour l'excrétion urinaire ;  
- pour le  $^{239}\text{Pu}(\text{NO}_3)_4$ , à partir du 12<sup>ème</sup> jour après inhalation, pour l'excrétion fécale et du 50<sup>ème</sup> jour pour l'excrétion urinaire.

Ce phénomène est dû au fait qu'au delà du 10<sup>ème</sup> jour, la majeure partie des quantités excrétées proviennent de l'épuration pulmonaire à vie longue soit par remontée vers les bronches pour les excrétions fécales, soit par transit dans les ganglions lymphatiques pulmonaires ou diffusion à travers le parenchyme pulmonaire pour les excrétions urinaires.

c) pour l'excrétion fécale, le rapport entre l'activité totale excrétée pendant les 4 premiers jours et l'activité excrétée en 24 heures, un mois après l'inhalation, est :

- pour le  $^{239}\text{Pu}(\text{O}_2)_2$ 
  - de  $3.10^4$  pour un aérosol de 10  $\mu\text{m}$
  - de  $3.10^3$  pour un aérosol de 1  $\mu\text{m}$
  - de  $10^2$  pour un aérosol de 0,2  $\mu\text{m}$
- pour le  $^{239}\text{Pu}(\text{NO}_3)_4$ 
  - de  $3.10^3$  pour un aérosol de 10  $\mu\text{m}$
  - de 350 pour un aérosol de 1  $\mu\text{m}$
  - de 110 pour un aérosol de 0,2  $\mu\text{m}$

Ces différences s'expliquent par le fait que la portion des particules inhalées déposées dans les voies aériennes supérieures est de 99 % pour un aérosol de 10  $\mu\text{m}$ , et que cette même portion n'est plus que de 56 %.

d) Les excrétions urinaires et fécales sont indépendantes de la granulométrie

- entre le 5<sup>ème</sup> et le 7<sup>ème</sup> jour pour l'excrétion fécale de  $^{239}\text{Pu}(\text{NO}_3)_4$
- entre le 6<sup>ème</sup> et le 7<sup>ème</sup> jour pour l'excrétion fécale de  $^{239}\text{Pu}(\text{O}_2)_2$
- entre le 21<sup>ème</sup> et le 27<sup>ème</sup> jour pour l'excrétion urinaire de  $^{239}\text{Pu}(\text{NO}_3)_4$
- entre le 50<sup>ème</sup> et le 60<sup>ème</sup> jour pour l'excrétion urinaire de  $^{239}\text{Pu}(\text{O}_2)_2$

### REFERENCES

- (1) MORROW, P.F., Task Group on Lung Dynamics, "Deposition and Retention Models for Internal Dosimetry of the Human Respiratory Tract", Health Phys., 12, 2 (1966) 73
- (2) DURBIN, P.W., "Plutonium in man - A New Look at the old data in Radiobiology of Plutonium", University of Utah (1972)
- (3) DOLPHIN, G.W., EVE, I.S., "Dosimetry of the gastrointestinal Tract", Health Phys., 12, 2 (1966) 163

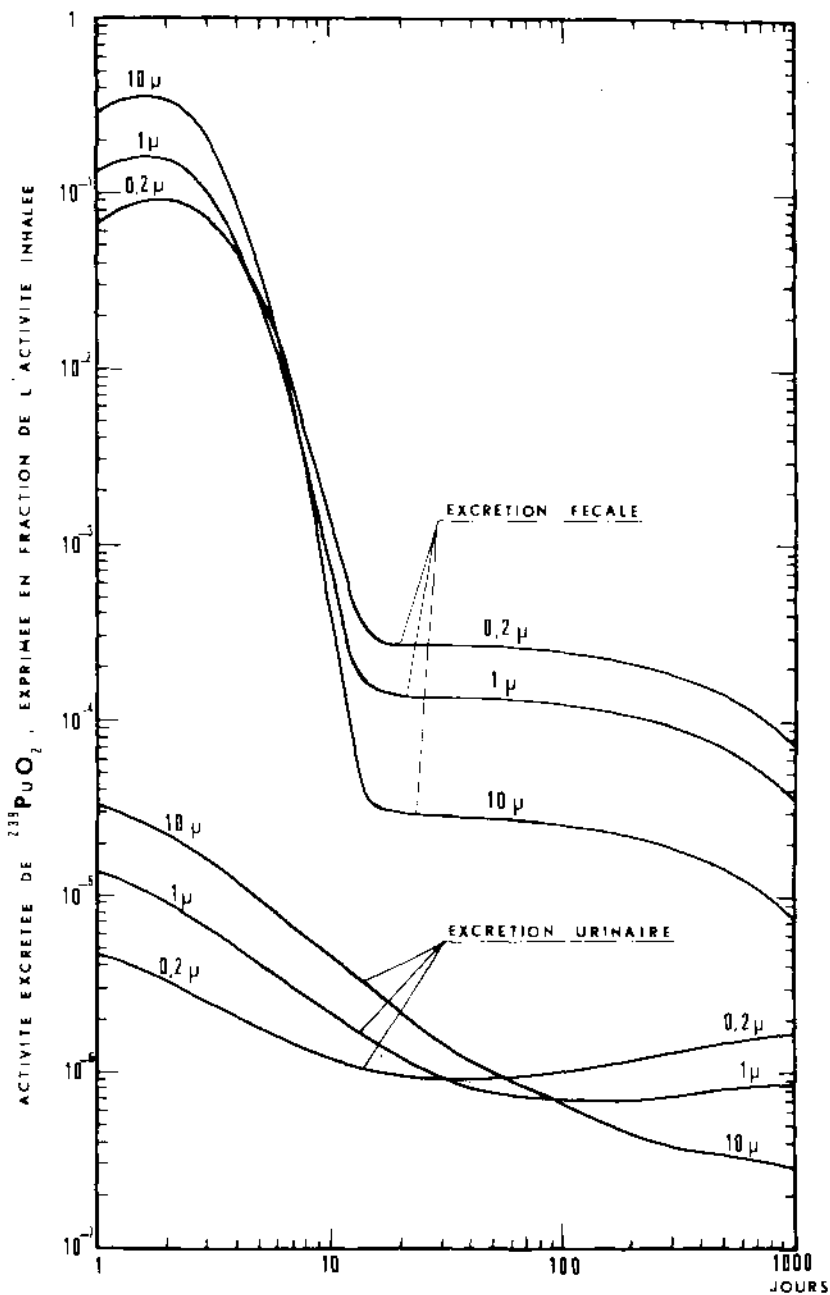

FIG. I VARIATIONS DES EXCRETIONS URINAIRE ET FECALE DE  $^{239}\text{PuO}_2$  EN FONCTION DU TEMPS APRES UNE INHALATION UNIQUE POUR 3 GRANULOMETRIES DES PARTICULES INHALEES : 0,2, 1, 10  $\mu\text{m}$

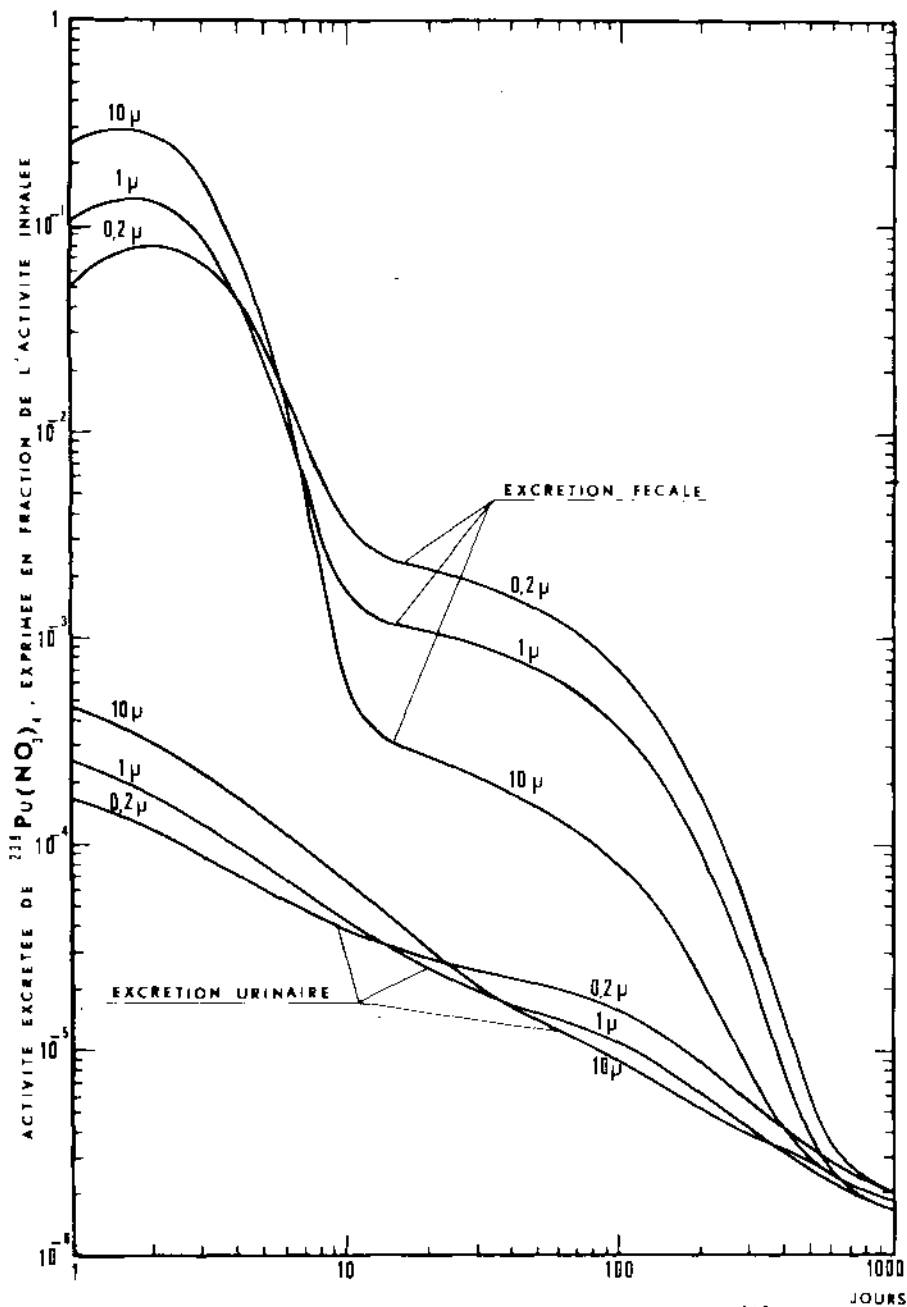

FIG. II VARIATIONS DES EXCRETIONS URINAIRE ET FECALE DE  $^{239}\text{Pu}(\text{NO}_3)_4$  EN FONCTION DU TEMPS APRES UNE INHALATION UNIQUE POUR 3 GRANULOMETRIES DES PARTICULES INHALEES : 0,2, 1, 10  $\mu\text{m}$

## DOSE ESTIMATIONS FOR INDIVIDUAL HUMAN ORGANS

J. M. Pacyna  
 Environments Protection Engineering Institute  
 Technical University of Wrocław, Poland.

INTRODUCTION

Investigations carried out so far at the Wrocław Technical University were aimed at determining the pathways of radionuclides through particular environmental media, and providing a classification of radioactive substances with special emphasis placed on Sr-90 and Cs-137. The results obtained were presented at the Amsterdam Congress of IRPA. However, it has not been accurately explained to what extent man is exposed to radiation. There is still a doubt about the estimates of radiation impact on the exposed tissue, the dose distribution, the size of the exposed tissue, and the relationship between dose rate and dose efficiency.

EXPERIMENTAL AND RESULTS

The amounts of radionuclide intakes have been determined. These intakes result from the presence of radionuclides in the environment (whole-body dose), in the ambient air (lung doses from inhalation) and in the diets (doses due to ingestion). Radioisotopes deposited in the human organism also contribute to the total intake. To determine doses due to inhalation, measurements were made for air concentrations of Rn-222, Rn-220 and long-lived isotopes. The results are listed in Table 1. Doses introduced into the body through ingestion were estimated on the basis of radionuclide contents in the diets. The contamination of diets is in the most part due to doses from Sr-90 and Cs-137. Measurement results are shown in Table 2. To determine the whole-body dose, concentration data were established for standard man from bone, muscle and gonad sample testing. Total beta- and gamma-activities of the ash, as well as Ra-226, Cs-137, Po-210, Sr-90, Ca and K contents, were determined. Based on potassium concentration, the concentration of radioactive K-40 which forms 0.0119% of the overall potassium, was estimated. Measurement results for gonads are listed in Tables 3 and 4 for man and woman, respectively.

The standard man is an individual characterized by a size of 1.70 m, a weight of 70 kg and a life-time of 70 years. The weight of the skeleton (excluding marrow), muscles, heart, testicles, and ovaries was 7 kg, 30 kg, 9.3 kg, 40 g and 8 g, respectively. After having burnt the soft tissues, 400 g of ash was obtained; burnt bone gave 1425 g of ash. Dose rates from the radionuclides tested to the critical tissues of standard man were calculated. Results are presented in Table 5. During our experiments emphasis was focused on the calculation of yearly radiation impact resulting from both man-made and natural radioisotopes (Table 6).

Gamma radioisotopes in samples were determined by using a gamma spectrometer. Beta radioisotopes were separated by radiochemical analyses and determined by a low-level anticoincidence beta counter, while alpha radioisotopes were measured by means of alpha scintillators.

CONCLUSIONS

1) The radioactivity of aerosols over the City of Wrocław results mainly from the presence of Rn-222 (93.3%). Radioactivity due to

Rn-220 equals some 6.6%. Lung doses from inhaled Rn-222 fall in the range of 630 mrad/yr.

2) Sr-90 and Cs-137 are introduced through ingestion. After having estimated the radionuclide contents of diets, it was found that Sr-90 doses resulted from cereals (41.4%) and milk (41.4%) intakes, whereas doses from Cs-137 were in the most part (69.0%) due to the intakes of milk and milk products. Sr-90 is characterized by a long-term retention in bone. This is largely true for osteogenetic tissue, hematopoietic marrow, and periosteum. Bone doses from Sr-90 intakes are 6.68 mrad/yr, while whole-body doses due to ingestion of Sr-90 equal 0.70 mrad/yr. Cs-137 is being removed from the organism. To determine the exposure rate, a whole-body dose from Cs-137 equal to 0.038 mrad/yr was selected.

3) Po-210 and Ra-226 are deposited in bone, too, whereas the deposition of Po-210 was found to be four times that of Ra-226. Yearly bone dose from Po-210 falls in the range of 0.035 mrad. Bone dose due to Ra-226 equals 1.38 and 0.59 mrad for bone cells and Haversian canals, respectively.

4) The highest dose rate to soft tissue resulted from K-40. The estimated gonad dose was 20.34 mrad/yr.

TABLE 1. AVERAGE MONTHLY AIR CONCENTRATIONS (1974-1976)

MONTH	Average radioactivity (pCi/m <sup>3</sup> )		
	<sup>222</sup> Rn	<sup>220</sup> Rn	Long-lived isotopes
January	236	18.2	absent
February	163	11.0	absent
March	254	20.7	0.3
April	108	9.2	0.6
May	93	6.3	0.1
June	106	13.5	absent
July	112	14.8	absent
August	63	8.4	absent
September	75	10.0	absent
October	419	31.8	0.9
November	456	32.3	0.6
Average	189	16.0	0.2

TABLE 2.  $^{90}\text{Sr}$  AND  $^{137}\text{Cs}$  CONTENTS IN DIETS

No.	Food	kg/year	$^{90}\text{Sr}$			$^{137}\text{Cs}$		
			pCi/kg	pCi/year	Total contamin. %	pCi/kg	pCi/year	Total contamin. %
1.	Milk and milk products	412.0	1.20	494.4	41.1	4.9	2018.6	69.0
2.	Meat	70.9	0.58	41.4	3.4	2.3	163.1	5.6
3.	Cereals	125.0	3.97	497.3	41.4	27.5	343.7	11.8
4.	Vegetables	276.0	0.52	143.5	11.9	0.97	267.7	9.2
5.	Drinking water	642.0	0.04	25.7	2.2	0.2	128.4	4.4
	Total			1202.3	100.0		2921.7	100.0

 TABLE 3. TOTAL BETA- AND GAMMA-ACTIVITIES (INCLUDING  $^{210}\text{Po}$ ,  $^{226}\text{Ra}$ ,  $^{90}\text{Sr}$ ,  $^{137}\text{Cs}$ ,  $^{40}\text{K}$ , Ca and K contents) IN STANDARD MAN

Age	Gross- $\beta$		Gross- $\gamma$		$^{226}\text{Ra}$		$^{210}\text{Po}$		$^{137}\text{Cs}$		$^{90}\text{Sr}$		$^{40}\text{K}$		$^{90}\text{Sr}/\text{Ca}$	$^{137}\text{Cs}/\text{K}$
	S	B	S	B	S	B	S	B	S	B	S	B	S	B		
	nCi/capita		nCi/capita		pCi/capita		pCi/capita		nCi/capita		nCi/capita		nCi/capita			
> 30	84.0	21.4	16.8	5.7	11.4	31.4	9.4	255.1	0.64	0.07	0.15	2.3	85.2	11.4	2.35	5.35
30-44	92.4	24.2	17.2	5.7	17.7	32.8	9.8	179.6	0.72	0.09	0.27	2.9	86.0	17.1	2.86	5.84
45-60	97.7	31.4	21.2	6.6	12.2	41.3	10.9	156.7	0.72	0.13	0.26	3.3	83.6	21.4	3.40	6.51
< 60	87.2	27.1	15.2	5.6	11.0	29.7	10.4	183.8	0.60	0.07	0.17	2.4	76.8	14.3	2.52	4.97
Average	90.3	26.0	17.6	5.9	13.1	33.9	10.1	193.8	0.67	0.09	0.21	2.7	82.9	16.1	2.87	5.67

S = soft tissue, B = bone.

TABLE 4. TOTAL BETA- AND GAMMA-ACTIVITIES (INCLUDING  $^{210}\text{Po}$ ,  $^{226}\text{Ra}$ ,  $^{90}\text{Sr}$ ,  $^{137}\text{Cs}$ ,  $^{40}\text{K}$ , Ca AND K CONTENTS) IN STANDARD WOMAN

Age	Gross- $\beta$		Gross- $\gamma$		$^{226}\text{Ra}$		$^{210}\text{Po}$		$^{137}\text{Cs}$		$^{90}\text{Sr}$		$^{40}\text{K}$		$^{90}\text{Sr}$ Ca	$^{137}\text{Cs}$ K
	S	B	S	B	S	B	S	B	S	B	S	B	S	B		
	nCi/capita		nCi/capita		pCi/capita		pCi/capita		nCi/capita		nCi/capita		nCi/capita			
>30	90.8	20.0	18.0	6.3	11.9	29.9	9.2	222.3	0.64	0.06	0.18	2.1	90.0	14.2	2.16	5.09
30-44	90.4	22.8	17.2	4.7	11.2	34.2	9.5	183.8	0.68	0.11	0.24	2.8	90.0	19.9	2.79	5.43
45-60	88.8	19.9	17.6	4.0	10.1	30.6	10.1	158.2	0.60	0.10	0.18	2.4	88.4	18.5	2.38	4.87
<60	82.0	12.8	16.4	2.6	11.9	32.8	9.4	200.9	0.44	0.10	0.17	2.3	81.5	12.8	2.18	3.78
Average	88.0	18.9	17.3	4.4	11.3	31.9	9.6	191.3	0.59	0.09	0.19	2.4	87.5	16.4	2.38	4.82

S = soft tissue, B = bone.

TABLE 5. DOSE RATES TO CRITICAL TISSUE (K) FROM  $^{226}\text{Ra}$ ,  $^{210}\text{Po}$ ,  $^{40}\text{K}$ ,  $^{137}\text{Cs}$ , AND  $^{90}\text{Sr}$  FOR STANDARD MAN

Tissue	$^{137}\text{Cs}$		$^{90}\text{Sr}$		$^{40}\text{K}$		$^{226}\text{Ra}$		$^{210}\text{Po}$	
	nCi	%	nCi	%	nCi	%	nCi	%	nCi	%
	Soft tissue	0.63(K)	0.730	0.20	0.232	85.42(K)	99.012	12.12	0.014	9.83(K)
Bone	0.09	0.471	2.54(K)	13.298	16.26	85.063	32.81(K)	0.172	192.43	1.007
Whole body	0.72	0.683	2.74	2.600	101.68	96.482	44.93	0.043	202.26	0.192

TABLE 6. YEARLY EXPOSURE

Isotope	Dose mrad/year	Percent of total intake %	Reference organ
$^{40}\text{K}$	20.34	3.08	gonads
	00.01	0.001	whole body
$^{222}\text{Rn}$	630.00	95.45	lungs
$^{226}\text{Ra}$	0.04	0.006	whole body
	1.38	0.210	bone cells
	0.59	0.089	Haversian canals
$^{210}\text{Po}$	0.004	0.005	whole body
	0.035	-	bone tissue
$^{90}\text{Sr}$	6.86	1.040	bone tissue
	0.70	0.106	whole body
$^{137}\text{Cs}$	0.038	0.006	whole body
Total	659.997	99.993	



## EARLY CLEARANCE OF INHALED RADIOCOBALT

AUTHORS: Dr. Gordon Riel, P.E.  
1010 Schindler Drive  
Silver Spring, MD. 20903

G. L. Jarvela & J. S. Richmond  
Wisconsin Public Service Corp.  
Route #1, Box 48  
Kewaunee, Wisconsin 54216

INTRODUCTION

An accidental exposure to airborne radioactive cobalt combined with the prompt and repeated analysis of body burden, urine, and fecal concentrations afforded us the opportunity to report early clearance rates for cobalt from the body. Such data on human subjects is much needed, but rarely seen (Bh74, Gu72, Se70). Our main purpose here is to present all the data obtained for the use of those skilled in constructing predictive models. We have attempted to fit the data to three models. Accidental exposures are not controlled experiments. In this case the Co particle size, concentration in air, dietary intake, and total quantity of elimination from the subjects is unknown.

2. THE EXPOSURE

The exposure occurred during a scheduled refueling. The subjects were under the supervision of contractor personnel. Some of the factors noted below were contrary to the WPSC procedures which the contractor had been instructed to use. The subjects were cleaning head bolts on the refueling floor. They used wire brushes and no respirators. Subject I cleaned one bolt, using acetone. Subject II cleaned several (5 to 10) bolts using a lubricant. Subject III cleaned 24 bolts using only a wire brush. Subject II was seated between I and III. The first indication of contamination was on the hand and foot monitor as the subjects left the area. The contamination was insufficient to raise the airborne-radioactivity in the large space above that normal during refueling ( $3.7 \times 10^{-10}$  uCi/cc for  $^{58}\text{Co}$ ). Surface contamination was found on the workbench and tools approximately 9,648 dpm/100 cm<sup>2</sup>. The acetone wet rag measured one R/Hr on a survey meter probe held against it. Loose contamination and clothing were removed. The subjects went immediately to the whole body counter. The background of the counter was about the same before and after counting them, so most loose radioactivity must have been removed by the first decontamination. Repeated swabs of nasal and aortic orifices were required during initial decontamination on subject 1 and 2.

3. COUNTING TECHNIQUE

Helgeson Nuclear Services (He 76) provided the whole body counter and analyzed the samples. The moving bed shadow shield whole body counter uses a 20 cm (eight inch) diameter by 10 cm (four inch) thick NaI(Tl) low background integral crystal-photomultiplier assembly. The standard counting time (eight minutes) resulted in a minimum sensitivity (two sigma) of 2.0 nCi for  $^{58}\text{Co}$  and 1.6 nCi for  $^{60}\text{Co}$ . All errors stated in the tables are two sigma, except numbers after "less than" are three sigma. Uncertainties in fecal counts (two sigma) are 50% or less.

4. RESULTS

Table I. gives data on the subjects and decontamination procedures  
Table IV. presents the whole body counting data  
Tables II, and III., respectively, report the concentrations in urine and feces. The accuracy of three models used to predict body burdens is reported in Table V.

5. DISCUSSION OF MODELS5.1 Urine and Fecal concentrations Table V-1

Prediction of body burdens from urine concentration would demonstrate confidence in our knowledge of cobalt metabolism (Se70). For convenience, as in screening, this relationship is an attractive supplement to whole body counting. To compare urine and whole body data at the same time, we inter-related from a plot of whole body counts at the times of urine sample collection. In Table V-1. the Root Mean Square error between the predicted and actual body burden as various times is reported as either % or nanocuries. We show the one which makes the model look better. In one case the error was constant as concentration decreased. In that case, error was reported in

nanocuries. In other cases the error decreased with concentration. In those cases error was reported in percent. For any one subject, the body burden can be predicted from the urine concentration, provided that, as some time, both are measured to obtain the constant, "K". If urine analysis alone is available, we still can make some estimates for screening. For example, the body burden in nanocuries is fairly certain to be less than ten times the urine concentration in picocuries per liter. The fecal concentrations parallel the urine concentrations, but with more scatter. We did not attempt to predict body burdens from the fecal concentrations.

### 5.2 Two Compartment Residence Time Model Table V-2

Plotting our data shows that, like the data of (Bh74), a portion, F, is eliminated more rapidly ( $\lambda_1$ ) than the portion (1-F) which is eliminated with  $\lambda_2$ . The  $\lambda$ 's are the first order rate constants integrating to the familiar:  $N(T) = N(0)e^{-\lambda T}$  where T is time. If these factors fully describe physiological behavior, then the factors would be independent of subject, isotope, and time. We find a reasonable prediction is made using for F,  $\lambda_1$ , and  $\lambda_2$ : 0.88, 0.85, and 0.005. These contrast with 0.69, 0.099, and 0.016 (computed from Bh74). Other values for  $\lambda$  quoted by (Bh74) are 0.46 and 0.006 (Jo65), 0.073 (ICRP 60), and 0.0165 (Se70). We do not propose that our result is the better, but rather that each is appropriate where determined. We do not have to go as far as India (as Bh did) to find individuals that differ considerably from the mean. In our subject I, a better fit was obtained for  $^{60}\text{Co}$  by developing factors for it rather than using those for  $^{58}\text{Co}$  in the same subject. However, in applying these factors to subject II, both isotopes were best fit by the factors developed for  $^{58}\text{Co}$  in subject I. In two cases, addition of a constant to the results improved the fit.

### 5.3 Gupton and Browne (Gu72) Table V-3

Gupton and Browne fit long term (1600 day)  $^{60}\text{Co}$  oxide chest burden data from a whole body counter to the Task Group on Lung Dynamics (Ta66) model for class Y materials:

$$(1) \quad L(T) = 0.15 P_0 e^{-\lambda_r T} \left[ F_i \lambda_h T e^{-\lambda_h T} + (1-F_i) \times (1-e^{-\lambda_h T}) \right]$$

$$(2) \quad P(T) = P_0 e^{-\lambda_r T} (F_e e^{-\lambda_e T} + F_f e^{-\lambda_f T} + F_g e^{-\lambda_g T} + F_h e^{-\lambda_h T})$$

$$(3) \quad C(T) = P(T) + L(T) \quad (4) \quad B(T) = C(T) + 5.67 \times L(T)$$

Where: T is time (here in days)

P is the initial pulmonary deposition

$P^0(T)$  is the pulmonary burden as a function of time

L(T) is the pulmonary lymph node burden as a function of time

C(T) is the chest burden as a function of time

The (Ta66) values of the parameters are given below, with (Gu72) values in parenthesis, where different:

$$F_e = 0.05 \quad F_f = F_g = 0.40, \quad F_h = 0.15, \quad F_i = 0.10 \quad (0.60)$$

$$\lambda_f = 0.693, \quad \lambda_e = \lambda_g = \lambda_h = \lambda_i = 0.0019 \quad (0.0031)$$

$$\lambda_r = 0.00971 \text{ for } ^{58}\text{Co} \text{ and } 0.00036 \text{ for } ^{60}\text{Co}$$

We used B(0) for the indicated range in place of  $P_0$  and computed B(T). Equations 1, 2, and 3 give C(T). To get B(T) we added  $0.85 L(T)$  to C(T). This allowed for the burden in the lymph system not in  $0.15$  the pulmonary region. We show the fit for both C(T) and B(T). By adjusting  $F_e$  and  $\lambda_e$  as indicated, a reasonable fit was obtained. Either value for  $F_i$  and  $\lambda_h$  gave about the same result. We tried a wide range of values for this parameter and found, in the time range covered, L(T) changed only a little as we varied these parameters. The main effect of L(T) was to make the fit worse. The body burden increased with the increasing time after eight days. Now it is reasonable for the lymph burden to increase, but the total body burden must decrease with time. Therefore our use of this model was inappropriate. P(T) is little influenced by L(T) in the first 30 days. Thus, the fit we obtain for C(T) would be obtained

with any exponential and does not use the special features of this one.

REFERENCES

- 1) BHAT, I. S., HEDGE, A. C., CHANRAMOULI, S., and TYER, R. S. 1973 Health Phys 25, 135 "Evaluation of Internal Exposure to Radionuclides of I, Cs, and Co During Maintenance Operations on Primary Steam Leak in a Nuclear Power Station"
- 2) CUPTON, E. D. and BROWNE, P. E. 1977 Health Phys, 23, 767 "Chest Clearance of Inhaled Cobalt-60 Oxide."
- 3) Helgeson Nuclear Services 1976 Pleasanton, California 94566
- 4) ICRP 1968 Publication 10, Pergamon Press, Oxford
- 5) JORDAN, R. D. 1965 in "Radioactivity in Man" Second Symposium, Sept. 1962 C. C. Thomas, Springfield, Illinois
- 6) SEDLET, J. and FAIRMAN, W. D. 1970 IRPA Second Congress "Elimination of Radioactive Cobalt following Acute Accidental Inhalation"

TABLE I - SUBJECTS

SUBJECT	WEIGHT	AGE	REMARKS	DECONTAMINATION PROCEDURE/TIME
I	214#	49	Slight Cold	Decontamination Shower /20Days 2Hrs. Shampoo, scrub arms /20Days and nose /20Hrs. Amifetamine / (over-the-counter)
II	183#	56		Decontamination Shower /20Days 2Hrs.
III	177#	28	Constipation until day 1	Decontamination Shower /20Days 2Hrs.

TABLE II. GAMMA ANALYSIS OF URINE

SUBJECT	DAYS AFTER EXPOSURE	<sup>58</sup> Co		<sup>60</sup> Co	
		pCi/l	2 SIGMA	pCi/l	2 SIGMA
I	0.17	41000		430	40
I	0.71	34000		250	50
I	1.00	17000		<200	
I	2	20000		120	20
I	3	11000		<180	
I	3.89	3200	200		
I	5.88	1700	200		
I	6.91	1400	230		
I	9	1300	200		
J	10	850	150		
II	0.67	240	70	<70	
II	0.83	170	30	50	
II	1.00	110	30		
II	2	90	20		
III	1	1100	100	<50	

TABLE III. GAMMA ANALYSIS OF FECAL SAMPLES

SUBJECT	DAYS AFTER EXPOSURE	<sup>58</sup> Co pCi/g		<sup>60</sup> Co pCi/g	
		WET	ASH	WET	ASH
I	1	970	3.5E+4	60	2000
I	2	2000	8.3E+5	110	4200
I	3	90	3700	4	1600
I	4	5	250	<0.3	<10
I	6	4	170	<0.1	<5
I	7	5	200	<0.1	<5
I	8	9	190	0.3	6
I	9	8	210	0.3	7
II	2	250	3600	15	220
II	3	97	400	6	250
II	5	14	530	0.7	25
II	6	5	160	0.3	10
II	7	1	45	0.03	1
II	8	0.1	5	<0.2	<7
II	9	0.06	2	-	-
II	10	0.1	3	-	-
III	3	400	5800	30	400

TABLE IV. URINE BODY COUNTS

SUBJECT	DAYS AFTER EXPOSURE	$^{58}\text{Co}$		$^{60}\text{Co}$	
		nCi	2 Sigma	nCi	2 Sigma
I	0.1775	9873	29	221	9.5
I	1.115	2863	16	174	4.9
I	1.97	1611	11	112	3.7
I	3.94	904	9.7	62	3.3
I	7.88	427	6.3	29	2.6
I	15.76	191	6.1	30	2.6
I	31.52	128	4.0	29	2.5
I	63.04	134	5.7	30	2.5
I	126.08	154	5.8	26	2.5
I	252.16	243	5	24	2
I	504.32	240	5	23	2
I	1008.64	250	5	24	2
II	9.271	347	5.5	30	2.7
II	18.542	269	4.6	19	2.4
II	37.084	99	3.4	12	2.3
II	74.168	44	2.6	10	2.1
II	148.336	23	2.7	4	1.9
II	296.672	9	2.0	-	1.6
II	593.344	5	1.5	-	1.6
II	1186.688	6	1.9	7	1.8
III	0.265	188	6.1	34	2.8
III	1.325	197	6.1	33	2.7
III	2.65	180	5.7	25	2.6
III	5.3	103	4.9	26	2.6
III	10.6	55	1.7	7	2.0
III	21.2	47	2.6	8	1.9
III	42.4	31	2.4	-	1.6
III	84.8	37	2.4	10	1.9
III	169.6	56	2.8	10	2.0

Table V. Models for Calculation of Cobalt Body Burden

Subject	Days After Exposure	Isotope	Values of Parameters		RMS Error
			$F$	$\lambda_f$	
V-1. Calculation of Body Burden from Urine Concentration					
$B(T) \text{ (nCi)} = K \times U(T) \text{ (}\mu\text{Ci/l)}$					
I	0 to 8	$^{58}\text{Co}$	$K = 0.2$		26%
I	3 to 8	$^{58}\text{Co}$	$K = 0.17$		102 nCi
II	0 to 2	$^{58}\text{Co}$	$K = 1.6$		2%
III	1	$^{58}\text{Co}$	$K = 0.37$		One Point
I	2	$^{60}\text{Co}$	$K = 1.09$		One Point
I	0 to 8	$^{58}\text{Co}$	$B(T) = (0.087 + 0.0203T)U(T)$		12%
V-2. Calculation of Body Burden from Initial Burden and Time by Two Compartment Residence Time Model					
$B(T) = B(0)e^{-\lambda_f T} [e^{-\lambda_f T} + (1-F)e^{-0.005T}]$ $\lambda_f = 0.00911$ ( $^{58}\text{Co}$ ), $0.00216$ ( $^{60}\text{Co}$ )					
			$F$	$\lambda_f$	
I	1 to 24	$^{58}\text{Co}$	0.88	0.85	55 nCi
II	2 to 7	$^{58}\text{Co}$	0.88	0.85	7.7 nCi
II	2 to 7	$^{58}\text{Co}$	0.95	0.87	7.5 nCi
I	1 to 24	$^{60}\text{Co}$	0.88	0.85	8.7 nCi
I	1 to 24	$^{60}\text{Co}$	add 6.17 nCi to above $B(T)$		5.7 nCi
II	0 to 4	$^{60}\text{Co}$	0.88	0.85	2.2 nCi
II	0 to 4	$^{60}\text{Co}$	add 1.28 nCi to above $B(T)$		1.8 nCi
II	0 to 4	$^{60}\text{Co}$	0.95	0.87	3.4 nCi
V-3. Calculation of Body Burden from Compton & Brown (OU 72) Model for $C(T)$ and as modified for $b(T)$					
			$F_f$	$\lambda_f$	RMS Error nCi
I	1 to 24	$^{58}\text{Co}$	0.886	0.837	56 84
II	0 to 1	$^{58}\text{Co}$	0.886	0.837	28 -
II	2 to 7	$^{58}\text{Co}$	0.886	0.837	5.5 -
II	2 to 7	$^{58}\text{Co}$	Subtract 5 nCi from above $B(T)$		2.9 -
I	1 to 24	$^{60}\text{Co}$	0.886	0.837	7.9 7.1
II	0 to 7	$^{60}\text{Co}$	0.886	0.837	2.8 -
I	1 to 24	$^{58}\text{Co}$	0.92	0.75	16 53

DOSE ESTIMATIONS FOR RADIOACTIVE *cis*-DICHLORODIAMMINE  
PLATINUM (195m) II - A NEW RADIOPHARMACEUTICAL

T. Schlesinger\*, G. Manaka and W. Wolf  
University of Southern California  
Los Angeles, California

## 1. INTRODUCTION

The inorganic antineoplastic agent *cis*-diamminedichloro platinum (II) (*cis*-DDP, NSC-119875) has been shown to be active as a single agent in several tumors such as those of gonadal origin (1), squamous cell carcinoma, (2), etc. and has shown promise in combination with other chemotherapeutic agents against other human solid tumors (3-5).

In view of the low therapeutic index and high toxicity (6) of this drug we feel that a rationale should be developed to determine drug administration schedules which would maximize the drug's effectiveness in an individual patient. Radiolabeled *cis*-DDP may serve as a useful tool in determining the appropriate pharmacokinetic parameters necessary to accomplish this task (7). Prior to using any new radioactive drug products in humans, however it is required to calculate the radiation doses expected in clinical use.

A preliminary and partial dosimetry for this drug based upon the biological data that were available at that time (8) has been published by this laboratory (9). The present work is based on a more complete analysis of the biological distribution of *cis*-DDP in rodents, both control and tumor bearing. Part of the biological work has been presented at the Third International Conference on Platinum Coordination Complexes in Cancer Chemotherapy (10).

This study may serve for dosimetry of patients and staff dealing with this agent. The MIRD pamphlets have not yet dealt with this radionuclide.

## 2. MATERIALS AND METHODS: ANIMAL DISTRIBUTION STUDIES

Male, Sprague-Dawley rats weighing 100-150g, both control and bearing solid Walker 256 carcinosarcoma, were injected with the radiolabeled *cis*-DDP at a dose of 1 mg/kg in normal saline by i.v. tail vein and placed in metabolic cages. At 0.5, 1, 3, 6, 12, 48 and 72 hours these animals were sacrificed and dissected. Values for percent injected activity per organ at the selected time periods for control rats are tabulated in table 1. Details on the synthesis, sampling and counting methods have been previously published (10).

## 3. DOSIMETRY

## 3.1 Basic physical parameters -

The principal physical parameters involved in the internal dose calculations for platinum-195m has been previously published (9).

## 3.2 Absorbed Dose Rates to Human Organs -

The absorbed doses per unit cumulated activities for 63 main source-target organ pairs are presented in table 2. These S values have been calculated using the basic physical data (9) and the absorbed fraction values from MIRD pamphlet No. 5 (11).

\*Permanent address: Soreq Nuclear Research Center, Yavne, Israel

### 3.3. Biological parameters -

The cumulated activities ( $\mu\text{Ci-h}$  per  $\mu\text{Ci}$  administered) in the organs were directly determined from the biological distribution studies (table 1) and are presented in table 3. These values were calculated by numerical integration of the fractional organ uptake versus time curves, using the trapezoid method

### 3.4. Absorbed Cumulated Doses to Reference Man -

Assuming that the biological distribution and retention functions in man will be similar or close to those in control rats, we assessed the cumulated doses to 7 principal human organs per unit activity of platinum- $^{195}\text{Pt}$ -*cis*-dichlorodiammine administered. These results are presented in table 4.

## 4. DISCUSSION

A definitive internal dosimetry of  $^{195}\text{Pt}$  *cis*-dichlorodiammine has been presented. From the results presented in table 4, it is evident that from the occupational radiation safety point of view, platinum- $^{195}\text{Pt}$ -*cis*-dichlorodiammine can be classified as a material having relatively low radiation toxicity. The critical organ is the kidney, which is also the organ where toxicity from the cold material is most significant. The organ receiving the second highest dose is the skin. Inasmuch as the skin has a relatively low radiation sensitivity, this will not present a radiation safety problem, although it does interfere with organ imaging studies of deeper organs, because of the radiation "envelope". The clinical utilization of this drug will result in radiation doses to several organs that are comparable to those delivered by a number of commonly used radiopharmaceuticals (12). Assuming that a typical procedure will involve the administration of 500  $\mu\text{Ci}$  for achieving the clinical results desired this will deliver a dose of the order of 2.2 Rads to the kidney, 0.5 Rads to the liver, 1.7 Rads to the skin, and a few millirads to the whole body.

It should also be noted that most of the radiation dose is due to non-penetrating radiation, and, as can be seen from table 2, the organ-organ doses are relatively small. Thus, the radiation dose to the organs with small drug uptake will be negligible. As an example, the uptake of the testes is roughly equivalent to that of the spleen (table 1), and although a direct calculation of the radiation dose to the gonads was not possible due to absence of absorbed fraction data, we can predict that the radiation dose will be of the same order of magnitude ( $5 \times 10^{-4}$  Rad/ $\mu\text{Ci}$  administered). Similar considerations can be made for the ovary.

The present study has provided a basis for the calculation of  $^{195}\text{Pt}$  dosimetry and specific dose estimations for  $^{195}\text{Pt}$ -*cis*-DDP. The radiation doses may be very different for other platinum complexes labelled with platinum- $^{195}\text{Pt}$ , because of their different retention and excretion characteristics. In addition, biological variation in the distribution and excretion of  $^{195}\text{Pt}$ -*cis*-DDP in diseased patients may also result in different radiation doses.

## REFERENCES

- (1) GOTTLIEB, J.A., et al., Cancer Chemotherapy Rept., 59 (Part 1): 621-628 (1975)
- (2) CARDONA, F.A., et al., Wadley Bulletin, 2, No. 3, 45, July (1972)

- (3) HILL, J.M., et al., Cancer Chemotherapy Reports, 59 (Part 1): 647-659 (1975)
- (4) (a) HAYES, D., et al., AACR Abstracts, p. 169 (1976)  
 (b) MERRIN, C., AACR Abstracts, p. 243 (1976)
- (5) (a) CVITKOVIC, E., et al., Proc. 3rd Intl. Conf. Pt. Coord. Compl. in CA Chemotherapy, Dallas (1976)  
 (b) CVITKOVIC, E., et al., Cancer Chemotherapy, Dallas (1976)  
 (c) CHARY, K.K., et al., Proc. 3rd Intl. Conf. Pt. Coord. Compl. in CA Chemotherapy, Dallas (1976)
- (6) (a) SCHAEFFI, J., et al., Toxicol. Appl. Pharmacol., 25:230-241 (1973)  
 (b) TALLEY, R.W., et al., Recent Results Cancer Res., 48: 160-166 (1974)
- (7) WOLF, W., et al., Proceedings of the 3rd Intl. Conf. Pt. Coord. Compl. in Cancer Chemotherapy, Dallas, Texas, October 1976, In Press.
- (8) WOLF, W., et al., in: "Radiopharmaceuticals and Labeled Compounds", Vol 11, IAEA, Vienna, p. 205 (1973)
- (9) SCHLESINGER, T. and WOLF, W., in: Radiopharmaceutical Dosimetry, R. Cloutier, Ed., FDA-76-8044, p. 452-9 (1976).
- (10) WOLF, W. and MANAKA, R.C., Proc. 3rd Intl. Conf. Pt. Coord. Compl. in Cancer Chemotherapy, Dallas, Texas, October 1976, In Press.
- (11) SNYDER, W.S., et al., J. Nucl. Med. Suppl. No. 3, NM/MIRD Pamphlet 5, Society of Nuclear Medicine (1969)
- (12) GRIMFIELD, M.A., and LANG, R.G., "Elements of Dosimetry", Table 8.6, p. 196, in "Radiopharmacy", M. TUBIS and W. WOLF, eds., J. Wiley-Interscience, New York, N.Y. (1976).

Organ	Time (Hrs.)						
	0.5	1	3	6	12	24	72
Blood	4.72±0.73	2.94±0.53	2.86±0.50	2.73±0.35	2.46±0.19	2.43±0.17	2.61±0.51
Skin	19.66±2.42	16.37±4.19	15.73±1.96	15.32±0.77	13.72±1.78	10.56±1.58	11.17±0.50
Thyroid	0.66±0.31	0.04±0.01	0.04±0.01	0.1±0.00	0.04±0.00	0.1±0.00	0.02±0.00
Liver	5.53±0.65	6.79±0.42	4.15±0.40	3.93±0.43	3.54±0.31	3.22±0.12	2.68±0.25
Spleen	0.22±0.07	0.12±0.01	0.20±0.06	0.14±0.04	0.13±0.02	0.27±0.05	0.12±0.02
Pancreas	0.16±0.04	0.11±0.02	0.13±0.03	0.12±0.03	0.12±0.05	0.13±0.02	0.12±0.02
Stomach	0.35±0.05	0.23±0.03	0.24±0.03	0.23±0.02	0.24±0.02	0.19±0.03	0.15±0.03
Testes	0.24±0.08	0.15±0.04	0.11±0.01	0.10±0.01	0.09±0.02	0.10±0.01	0.04±0.01
Fat	0.31±0.16	1.08±0.54	0.93±0.17	0.67±0.12	0.42±0.07	0.20±0.01	0.69±0.17
Kidneys	3.74±0.81	2.67±0.28	3.48±1.85	2.90±0.18	2.86±0.28	2.92±0.14	2.62±0.18
Adrenals	0.04±0.01	0.33±0.01	0.03±0.02	0.02±0.01	0.02±0.01	0.02±0.01	0.01±0.01
Heart	0.11±0.02	0.08±0.02	0.27±0.01	0.66±0.01	0.04±0.03	0.07±0.01	0.1±0.01
Lungs	0.56±0.25	0.40±0.08	0.40±0.04	0.39±0.04	0.25±0.17	0.29±0.02	0.28±0.04
Brain	0.37±0.21	0.06±0.01	0.56±0.02	0.03±0.00	0.05±0.12	0.05±0.02	0.02±0.01
Muscle	7.00±1.34	5.75±1.32	6.93±2.37	6.50±0.96	5.10±0.36	3.37±0.66	4.61±0.36
Bone	7.65±1.87	6.51±1.44	6.39±0.94	4.83±0.78	5.18±1.61	5.37±0.01	3.68±0.03
Uterus	0.34±0.21	0.04±0.01	0.33±0.00	0.02±0.00	0.07±0.01	0.01±0.01	0.01±0.01

TABLE I Tabulation of Percent Ejected Dose Per Organ at Selected Time Periods for Control Rats

Target Organs	Source Organs						Total Body
	Bladder	Kidney	Liver	Lungs	Spleen	Skin *	
Bladder	8.5 E-4	1.1 E-7	6.3 E-8	3.1 E-9	3.4 E-8	2.8 E-7	1.1 E-6
Bone (Total Marrow)	9.8 E-7	5.0 E-7	1.3 E-6	2.8 E-6	1.3 E-6	-----	2.1 E-6
Kidney	1.1 E-7	1.5 E-3	2.5 E-6	4.6 E-7	6.0 E-6	9.8 E-8	1.1 E-6
Liver	5.6 E-8	2.5 E-6	2.4 E-4	1.6 E-6	4.9 E-7	3.0 E-7	1.1 E-6
Lung	1.3 E-9	4.8 E-7	1.8 E-8	4.7 E-4	1.6 E-5	3.2 E-7	9.9 E-7
Spleen	4.9 E-8	6.2 E-6	1.3 E-6	1.5 E-6	2.4 E-3	3.0 E-7	1.1 E-6
Skin	2.8 E-7	9.8 E-8	3.0 E-7	3.2 E-7	3.0 E-7	2.1 E-4**	3.6 E-7
Uterus	1.5 E-5	4.3 E-7	1.9 E-7	2.3 E-8	1.9 E-7	-----	1.2 E-6
Total Body	7.3 E-6	1.1 E-6	1.2 E-6	2.1 E-6	1.2 E-6	3.8 E-7	6.8 E-6

\*S Values for skin as Source Organ were calculated by the reciprocity theorem.  
 \*\*Maximal value assuming that all raditions are totally absorbed.

TABLE 2 S, Absorbed Dose Per Unit Cumulated Activity (Rad/pCi-h) for Pt-195m.

Organ	S (pCi-h/ci administered)
Kidney	3.85
Liver	4.22
Lung	0.41
Spleen	0.21
Skin	16.20
Blood	3.67
Fat	0.89
Muscles	0.94
Marrow	0.25
Bone	5.95
Adrenals	0.18
Brain	0.43
Heart	0.79
Pancreas	0.15
Stomach	0.24
Spleen	0.15
Testes	0.14

TABLE 3 Cumulated Activities  
 A (pCi-h/ci administered)  
 for control rats

Organ	Dose (Rad/pCi administered)
Kidney	4.4x10 <sup>-3</sup>
Liver	1.0x10 <sup>-3</sup>
Lung	2.0x10 <sup>-4</sup>
Spleen	3.5x10 <sup>-4</sup>
Skin *	3.4x10 <sup>-3</sup>
Uterus	1.6x10 <sup>-3</sup>
Whole Body	9.4x10 <sup>-3</sup>

\*Not including self dose

TABLE 4 Calculated cumulated doses in  
 reference man per unit activity  
 of Platinum-195m, cis-  
 dichlorodiamine administered.



INTERNATIONAL RADIATION PROTECTION ASSOCIATION

PARIS, 25TH APRIL 1977

Sievert Lecture

THE TIME FACTOR IN CARCINOGENESIS

by

W. V. Mayneord, CBE, DSc, FRS

(Professor Emeritus of Physics as applied to Medicine,  
University of London.  
Consultant to the Central Electricity Generating Board.)

/ Downs Way Close, Tadworth, Surrey, KT20 5DR, England.

May I first express my appreciation of the great honour you have done me in choosing me as the second recipient of the Sievert Award with its accompanying invitation to deliver a lecture in his memory. I am deeply conscious of the distinction, and even puzzled at being thus chosen from among so many who have contributed to the development of the art and science of radiation protection. But perhaps you were influenced by the knowledge that Sievert and I were friends for some forty years, though I am not sure that this does not make my task heavier rather than lighter. As my distinguished predecessor, Dr. Bo Lindell, remarked, it is impossible to recreate in a few words the personality of Rolf Sievert, that genial but demanding giant. Rolf and I were first acquainted in the 1920's. Let me try to set the scene as I remember it.

Sievert was a member of a very remarkable group of pioneers led by Gösta Forssell, a distinguished radiologist moving in the highest social circles and undeniably the head of the Swedish medical profession. With him were Dr. Heyman, a gynaecologist whose work on the radium treatment of cancer of the cervix uteri was revolutionising practice throughout the world, Dr. Berven, a distinguished radiotherapist and the young Rolf Sievert, highly gifted and clearly destined to leadership among the small group of physicists who had ventured into this medical field. This was a time of great hope and optimism in radiation therapy. Here in Paris at the Fondation Curie another extraordinary group inspired by Madame Curie and led by Professor Claude Regaud and his brilliant colleague Lacassagne, were carrying the subject forward from a very different point of view. The Swedish group were particularly strong in the physical and mathematical as well as clinical sciences; the French school it seemed only secondarily interested in the physical aspects, concentrating their genius (for it was no less) on biological research as revealed for example in their "Radiophysologie et Radiothérapie" (1). There were at this time no nationally or internationally agreed units of dose or methods of measurement, and few quantitative studies of the distribution of radiation around radioactive sources of medical interest, meaning in those days "radium needles" inserted into tissues or body cavities.

In 1921 Sievert published his first important work "Die Intensitätsverteilung der primären  $\gamma$ -Strahlung in der Nähe medizinischer Radiumpräparate" (2). Its theoretical and practical importance was at once recognised and the mathematical skill obvious, but controversy was raised. Was the "intensity of primary gamma rays" what mattered in a scattering medium which itself contributed significantly to dose? I remember this discussion very well, being myself a pupil of Friedrich then much concerned with secondary scattered radiation and its significance. Sievert himself, of course, recognised the complexity of the problems and in 1923 published a second paper on "Secondary rays in radium therapeutics" (3) in which, as I re-read it, I realise how close he came to anticipating me by some twenty years on reciprocity theorems! Sievert's original paper (1921) we must remember was two years earlier than the discovery of the Compton effect and its resulting recoil electrons (1922-1923). We were still groping to find a physical agent capable of causing the undoubted biological effects of gamma rays. Sievert's papers inspired a new literature and approach to radiation distribution problems. They also, as an interesting sideline, earned him the distinction of being the only medical physicist to give his name to a definite integral. Rolf calculated tables of its values "by graphical methods", a formidable task. We now know that the integral is related to the error function, exponential integrals and certain integrals of Bessel functions. Though tables of values are now available to six significant figures I have yet to find an error in Rolf's original values!

It would be tedious and pointless to try to discuss Sievert's publications in detail. They should be savoured in the original, so I will mention only two or three which are particularly outstanding. His first paper on protection seems to have been in 1925, "Einige untersuchungen über vorrichtungen zum schutz gegen röntgenstrahlen" (4), in which he became concerned about secondary rays from walls, floor and ceiling. From this time onwards a stream of investigations into protection and standardisation problems may be traced.

In 1932 he published one of the masterpieces of radiological literature, his Supplement 14 to Acta Radiologica, "Eine methode zur messung von röntgen-, radium- und ultrastrahlung nebst einige untersuchungen über die anwendbarkeit derselben in der physik und der medizin" (5). "The method" is, of course, the use of small condenser chambers. This work, I think best illustrates his essential characteristics. The thorough theoretical grasp of the problem, the imaginative ingenuity, the outstanding experimental competence backed by the extremely high standards of technical execution we have come to expect from our Swedish colleagues, are here shown at their best. To the end of his life Rolf loved imagining and constructing with his own hands delicate and beautiful instruments, sometimes perhaps almost too delicate as were condenser chambers in the hands of less skillful workers. Which moves me to say that, like all the best scientists I have known, Rolf Sievert was essentially an artist, subject to the vagaries and vascillations of inspiration. This artistic trait appeared in a more conventional artistic form in for example his interest in and designs of objects in glass made under his direction, or in his love of music, particularly J. S. Bach. He was an enthusiastic and competent organist who built for himself a small "chapel" with an organ on the shores of a beautiful lake in his country estate in Southern Sweden. Those of us who were privileged to stay at his apartment in the Karolinska will remember, too, the delightful artistry of those rooms and the generous care for our comfort. Generosity was, indeed, an outstanding characteristic. He loved good living himself and loved providing and sharing it with his friends. Sometimes meals, as for example feasts of crayfish in the true Swedish tradition, became something of a challenge!

But let us return to his national and international interests and achievements. He was early a member of the International X-ray Unit Committee as well as Protection Committee of the International Congresses of Radiology following the very successful meeting in Stockholm in 1928 at which the röntgen was adopted as a unit of dose. His department became the central standardising laboratory in Sweden.

After the War, at the Congress in London in 1950, the international radiological organisations had to be completely reconstructed, sometimes in the face of considerable international tension. Sievert was a tower of strength. His personality and scientific standing, coupled with the political position of Sweden, were of great importance and it was inevitable that he should be a member of the newly-formed International Commissions of Protection and Units, with greatly increased public responsibilities, scope and independence of status. A little later the problems of environmental monitoring were uppermost in many minds and Sievert was responsible in Sweden itself for the setting up of an appropriate organisation and for developing with his usual skill high pressure ionisation systems. I remember well many earnest conversations with him on the need for detailed legislation of which he had great experience, its form and content. I think I personally preferred less detailed and less formal legal arrangements than he did, but time has shown the wisdom or at least necessity of his approach, and it was always a delight to discuss these matters with one so friendly, wise, sincere and helpful. My recollection is that he said relatively little in formal committees but his interventions were very effective and massive and he usually had his way! Perhaps our closest personal association came via the United Nations, both its Scientific Committee and Peaceful Uses Conference as well as the International Commission on Radiological Protection (ICRP).

Sievert was very seriously concerned with the problems of international relationships, fallout and population exposure. However, the United Nations Scientific Committee on the Effects of Atomic Radiation (UNSCEAR) quickly established itself and played a major rôle in the collection of universally acceptable data and in setting guide lines. Sievert certainly contributed greatly to the efficacy and clear discussions of that Committee and its speed of working. I remember Dag Hammershøld, then Secretary-General of the United Nations, expressing to me his astonishment at the speed with which the Committee had got down to work. UN officials had allowed us ten days of "preliminary discussion on procedure" yet we actually started serious scientific discussion on the first afternoon. Some of my most vivid memories of Sievert are of wandering with him along the slippy and interminable corridors of the Palais des Nations in Geneva or the palm-laden foyers of the UN Headquarters in New York, while he dissented with insight and humour the previous hours discussion. Perhaps you will forgive my immodesty if I show a photograph taken in Geneva, a rather less formal picture than that in "Health Physics" of the learned Chairman of ICRP.

Sievert certainly was a powerful Chairman of ICRP and could look forbidding and register annoyance quite distinctly and unmistakably, but ordinarily was extremely persuasive and persistent and carried his Committee with him by weight of experience and knowledge.

But I must conclude my sketch of Rolf. I would like to convey something of his greatness, something of his lovable humanity and generosity as well as overpowering intellect and artistic sensitivity. Whatever else he was, he was no Standard Man (a concept I suspect he would have rather despised) either in body or mind. I see him now, a towering mass of humanity, overflowing his chair in a way I have only ever seen equaled by one man, the

poet G. K. Chesterton. Rolf, like all good-natured men with a marked sense of humour, laughed at and enjoyed his own jokes. I would sometimes try to say a few words in Swedish. The great mass would begin to oscillate while a deep gurgle resolved itself into words - "Eet zounds zo fuorce when you say eed!" Which I am sure it did!

Rolf Sievert was one of the giants of radiological science, including protection. His energy, flow of ideas, enthusiasm and immense knowledge were phenomenal. His level-headed judgements were also bastions of common sense against extreme decisions whether of policy or permissible levels.

One other contribution I must mention in a very different field. There was at one period very considerable anxiety about money to carry on the work of the Protection Commission and here, too, his financial status and acumen were of great value. I remember well going with him in New York to open negotiations with the Ford Foundation and marvelling at his persuasive powers and skill in this field too.

He enjoyed his powers and eminence but apparently had little idea of the outstanding quality of his scientific achievements and as a result was extremely modest about them. He need not have been, for the spirit remains even though the precise technologies of ionisation chambers and mechanical electrometers have largely gone.

In the year 1941 Sievert published in Acta Radiologica a fascinating theoretical paper, "Zur theoretisch-mathematischen behandlung des problems der biologischen strahlenwirkung" (6). In it he discussed in his usual masterly way a very general mathematical theory of the action of radiation on the living cell in terms of the deviations from their normal values of concentrations of essential cell ingredients under irradiation at different dose-rates. Many times he expressed to me his concern lest the very high dose-rates in diagnostic radiology might be particularly hazardous. Sievert introduced the concept of a "latent period" depending on radiosensitivity and the presence and speed of reconstitution of reserves in the cell of relevant materials. Many simplifying assumptions must be made, but Sievert derived a series of differences or differential equations which though they could not be solved generally analytically were treated graphically. He applied this theory to the extensive series of results by his colleague Arne Forssberg on *Phycomyces* and *Drosophila* eggs. Sievert opens the paper with an eloquent encouragement to the mathematical biologist. Translating freely, "Human capacity to judge of the logical consequences of many factors acting together is very limited and it is often of the greatest importance to translate the observations into mathematical language and to use mathematical methods rather than attempt to proceed directly". True, his paper ends with words of warning, but I would like to use his invocation as an excuse for the rest of this lecture building on the foundations he laid. I wish I could think my superstructure as solid as his foundations!

It is universally agreed that one of the most important late effects of irradiation is the induction of tumours. As you are very well aware much effort has been expended in attempts to correlate biological effect with dose, often the total number of tumours observed in a population of animals with dose to relevant tissues or cells. The resulting dose response curve is then analysed in an attempt to throw light on essential mechanisms or to support estimates of effects to be expected in a given dose range.

An important feature of carcinogenesis is the long so-called "latent period" between the application of the carcinogen and the observation of the tumour, this time interval usually being greater the smaller the dose of the

agent, whether physical or chemical. What precisely is happening in that latent period we do not know but much evidence from pathology, cytology and many other fields suggests the occurrence of a series of events, mostly moving towards increasing abnormality and heterogeneity of structure of cells and tissues, until limited by abnormality so great as to lead to cell "death" or, rarely, capacity for increased and barely controlled cell division. "Latent" is a misleading term if it suggests "inactivity".

This is a vast subject and I can only indicate the briefest outline. Suffice it, that as we look at the detail we seem to be forced to recognise an element of chance in the processes. In the jargon of probability theory, each cell is a "trial", each cellular life history a "realisation" of a Random Walk or Markov chain, each tumour an outcome of complex interplay of inter- and intra-cellular events. Probably no two tumours are genetically, cytologically or immunologically precisely identical, yet from what miracles of precise mechanism they arose! Radiation introduces confusion, "genetic noise". In a deterministic sense carcinogenic agents, including radiation, do not "cause" cancer. They modify the probability of its later occurrence, often increasing that probability, sometimes decreasing it, altering the time scale of the events.

The idea that the essential action of radiation is to confer a probability of cancer in the future is not new. In 1949 Austin Brues (7) analysed the rate of appearance of osteosarcomas as a function of time and radioactive intake of a group of several thousand mice given monthly injections of the beta emitter  $^{89}\text{Sr}$ . He concluded, "that each quantity of absorbed radiation confers on the tissue absorbing it a probability (per unit time) of tumour formation which is without limit in time once the latent period is passed; thus the daily tumour morbidity will continually increase so long as further radiation occurs". (Figure 1).

In an admirable and important recent paper Marshall and Groer (8) modified the hypothesis by considering the effects of cell killing, thus limiting the time and number of cells over which the probability is significant.

Marinelli (9) earlier argued for risk per unit dose of alpha radiation chronically delivered remaining constant in time.

During the last three years or so Dr. Roger Clarke and I, following our studies of effects of spatial distribution of dose (10), have been thinking of the analogous time effects, and I would like to conclude with a very brief summary of some of our thinking.

We have approached the problem a little differently, abandoning the idea of a single latent period and asking rather, "Is there experimental evidence as to the form of the variation of probability of tumour appearance with time following an element of exposure?". That is, "What is the form of a possible probability density function?". On integration this form must evidently be such as to yield the familiar linear or S-shaped (ogee) response curve against time or perhaps dose.

Having been involved some forty years ago with Kennaway and his team (1) in the identification of aromatic hydrocarbons as the first "pure" carcinogens, and having still a feeling that radiation and chemical carcinogenesis must eventually be brought together, I looked first at some of the vast literature of chemical carcinogenesis. We can quote here only one notable set of experiments. In 1967 Druckrey (12) published an impressive account of an extensive series of investigations into quantitative aspects of

various chemical carcinogens, in which he established that the numbers and times of appearance of tumours were log-normally distributed against total dose. (Figure 2). For continuous dosage this often implies log-normal distribution of time of appearance. Moreover, if  $d$  is the daily dosage and  $t$  the median induction time he also established a relationship (namely  $dt^n = \text{constant}$ ) with  $n$  varying from about two to six, in different experiments with different materials. Results of this form have been obtained by many other workers with a range of chemical carcinogens (13) and in investigations extending even to cancer in smokers.

Druckrey's results (Figure 3) indicated a larger value of the standard deviation  $\sigma$  for leukaemia than for solid tumours, a point to which we will return later. The shorter latent period at higher dose is also apparent.

We naturally ask, "Does this same form of dose or time relationship hold for radiation carcinogenesis?" Early experiments by Blum (14) with ultra-violet light indicate that it does very precisely, while recently Albert and Aitshuler (15) produced evidence that for ionising radiations the log-normal form is again at least a useful approximation (Figure 4), which may be used to calculate, for example, the average life shortening of an irradiated human population. While feeling considerable scepticism about any "universal" relationship in biology there seems sufficient evidence to justify a particularly careful look at this log-normal form of time delay.

We must leave aside mathematical detail, but may I just remind you that the log-normal density distribution is indeed Protean, (Figures 5 and 6) being nearly Gaussian for low values of the standard deviation ( $\sigma$ ) while for higher values of variance ( $\sigma^2$ ), that is greater heterogeneity of the "population", the density becomes very skew with highest values of probability (mode) at low values of the variable. When we integrate to obtain cumulative response functions against time (and perhaps dose) we deduce responses of varying shapes depending greatly on the variance and median. We have three variables, time, variance and response, so that we need a surface to represent our data. My colleague, Dr. Clarke, has produced computer generated drawings of such surfaces as, for example, that showing probability density (Figure 7) or integrated response (Figure 8).

May I add that we have recently analysed as probits a number of sets of data and found approximate agreement with this form. Experimental data expressed as "logit" are probably satisfactorily recast as "probit". We have also investigated changes of  $\sigma$  with dose and with concentration of radioactive material as "point sources". Data on leukaemia in Hiroshima and Nagasaki (16) fit this form (Figure 9). It is interesting to try to study variation of  $\sigma$  with dose in radium dial painters (Figure 10).

What does all this imply? One thing it does not imply, that there is any exclusive correlation between the log-normal distribution of time delay and cancer. The form is of extremely general application far outside our field, in biology, economics, physiology, psychiatry, chemistry, and even the study of conservation of works of art, or routine observations of the gamma-ray dose around fuel element treatment ponds at AERE! Essentially we have moved from the study of individual interactions to the statistics of heterogeneous populations. Let me quote just one example of how these ideas may help us.

In the 1972 Report of the United Nations Committee (UNSCEAR) there is a very interesting paragraph which reads as follows, "The data from experiments with low LET radiation suggest that the more resistant the tissue to tumour induction, the more likely that the dose response will be curvi-linear or sigmoid, and the more sensitive the tissue to radiation, the

more likely that linear dose-response curves for tumour induction will be observed. Likewise, linear dose-response curves are seen where the spontaneous incidence of neoplasms is moderate to high, further suggesting that linearity of the dose-response curve is related to sensitivity to "tumour induction".

Our integrated response curves show precisely this. "Sensitive tissue" corresponds to low median dose (or time) and large variance since this brings low values of "mode", in which circumstances rough linearity is predicted by our integrations. As noted above, interestingly enough, our detailed analysis shows too that in both Bruckrey's chemical experiments and in Court-Browe and Doll's and Japanese data for leukaemia, the standard deviation of the log-normal plot for these diseases is higher than for most solid tumours. Coupled with low median dose this immediately leads to the prediction of a linear response, raising again the question as to whether the leukaemias are not a very complex set of diseases arising from a very heterogeneous set of cells. It is of interest that from a different point of view Baum (17) discussed population heterogeneity in relation to radiation-induced cancer. A study of the log-normal cumulative probability curves show how easily various linear or power law response curves may be derived following variation of  $\sigma$ , (Figure 11).

We have recently extended our calculations to more complex situations in which the (median) latent period is assumed to decrease with dose already delivered, this again producing changes in the expected response curves, particularly predicting high response at long times.

It is clear that the assumptions of a probability density function for "latent period" opens new possibilities in interpretation of response functions, particularly for continuous irradiation with low LET radiations. I may add that the assumption of cumulative log-normal survival curves (for which there is evidence) (Figure 12) superimposed on response curves is also proving extremely interesting in predicting "peaked" response, (Figure 13).

Let us agree, that radiation confers a distributed probability of a future event, carcinogenesis. How is the probability as it were "conveyed" in time, and how is it eventually "realised"? We must, I think, turn to molecular biology. Modern biology has become increasingly interested in the mechanisms of transference of instructions required by a living cell to continue its metabolism, to transmit the required information to the next generation of cells when it divides, or perhaps differentiate into a cell destined to perform a specific function in the organism. Radiation causes point mutations, chromosome aberrations and innumerable transient changes, thus destroying organisation, increasing entropy, interfering with information transfer, and increasing confusion (18). Mathematical Information Theory in one form (19) links "information" with the reciprocal of the variance of a "normal" population, just as we have linked the shape of the response curve. A cell lineage is a communications system and it is therefore not surprising that so-called Information Theory or Communication Theory seems to furnish the appropriate mathematical techniques. We move towards our biological colleagues in assuming heterogeneity and try to extract useful information from that diversity. Cell turnover times are sometimes log-normally distributed, "latent period" may be drastically reduced by the application of non-carcinogenic "promoters" or viruses. Cells respect metabolic change rather than the dials of grandfather clocks! Maybe we have now the possibility of improving on the rather disappointing contributions from Information Theory as applied to biology in the 1950's.

I think we must, in any case, move towards human biology. As physicists or engineers we are apt to concentrate excessively on the quantity we can measure - namely dose. This remark perhaps comes strangely from one like myself after a lifetime of interest in dosimetry, though I have always regarded it as merely a step towards biological understanding, but if we wish to take the important step from measuring dose to assessing risk to individuals and populations we shall be forced to pay more attention to, and to understand more of biological phenomena. It happens, that biophysics and biomathematics, with the help of computer technology are poised for rapid if somewhat erratic advance (20). Let us not forget that our aim is to protect people, not amass dose or other statistics though that is a useful and, indeed, indispensable activity.

But you will say, shall we not as practical men, be forced at present to use empirical relationships, to make our practical decisions? Yes - we shall - but being old-fashioned I still think that Science has something to do with understanding as well as manipulating phenomena to our own ends.

Such progress as we have made in the protection field has arisen, certainly from careful and intensive empirical observation, but also from attempts to understand mechanisms as, for example, those of mutagenesis and carcinogenesis. Such understanding has profoundly influenced our decision-making. I have no doubt that the increase in knowledge of biological mechanism now taking place will influence the scientific basis of protection against all environmental hazards, including radiation. In spite of the abuse sometimes levelled at us we have a sounder quantitative basis for our decisions than for those in any other "safety" field. We must nevertheless use every endeavour to strengthen our basic knowledge and widen our horizons. I make no apology for directing your attention to these basic concepts and how they may change in the future.

#### REFERENCES

1. RECUAT C. and LACASSAGNE, A., "Effets histophysiologiques des rayons de röntgen et de Becquerel-Curie sur les tissus adultes normaux des animaux supérieurs", Radiophysologie et Radiothérapie, Archives de l'Institut du Radium et de la Fondation Curie, Les Presses Universitaires de France, Vol. 1, Fascicule 1, (1927).
2. STEVERT, R., "Die Intensitätsverteilung der primären  $\gamma$ -Strahlung in der Nähe medizinischer Radiumpräparate", Acta Radiologica, Vol. 1, 89, (1921).
3. STEVERT, R., "Secondary rays in radium therapeutics", Acta Radiologica, Vol. 2, 268, (1923).
4. STEVERT, R., "Einige untersuchungen über vorrichtungen zum schutz gegen röntgenstrahler", Acta Radiologica, Vol. 4, 61, (1925).
5. STEVERT, R., "Eine methode zur messung von röntgen-, radium- und ultrastrahlung nebst einige untersuchungen über die anwendbarkeit derselben in der physik und der medizin", Acta Radiologica, Supplement 14, (1932).
6. STEVERT, R., "Zur theoretisch-mathematischer behandlung des problems der biologischen strahlenwirkung", Acta Radiologica, Vol. 22, 237, (1941).
7. BRILES, A.M., "Biological hazards and toxicity of radioactive isotopes", Journal of Clinical Investigation, Vol. 22, 1286, (1949).



8. MARSHALL, J.E., and GROER, P.G., "Theory of the induction of bone cancer by radiation. A preliminary report. 1. A three-stage alpha particle model and the data for radium in man", ANL-75-60, Part II, page 1, (July 1974 - June 1975).
9. MARINELLI, L.D., "The stability of leukemogenic risk in human marrow irradiated by alpha rays", ANL 7860, Part II, page 184, (July 1970 - 1971).
10. MAYNEORD, W.V. and CLARKE, R.H., "Carcinogenesis and radiation risk: A biomathematical reconnaissance", British Journal of Radiology, Supplement 12, (1975).
11. COOK, A.W., HIEGER, I., KENNAWAY, E.L. and MAYNEORD, W.V., "The production of cancer by pure hydrocarbons", Part I, Proceedings of the Royal Society, B, Vol. 111, 455, (1932).
12. BRUCKREY, H., "Quantitative aspects in chemical carcinogenesis. Potential carcinogenic hazards from drugs", IICG Monograph Series, Vol. 7, 60, (Ed. René Truhaut), Springer-Verlag, New York, (1967).
13. ARCOS, J., ARGUS, M.F. and Wolf, G., "Chemical induction of cancer", Academic Press, London and New York, (1968).
14. BLUM, H.F., "Carcinogenesis by ultra-violet light", Princeton University Press, Princeton, N.Y., (1959).
15. ALBERT, R.E. and ALTSCHULER, B., "Considerations relating to the formulation of limits for unavoidable population exposures to environmental carcinogens", Radioisotope Carcinogenesis, AEC Symposium Series No. 29, 233, (1975).
16. UNSCEAR, "Report of the United Nations Scientific Committee on the effects of atomic radiation. Ionising radiation: Levels and effects", Vol. 2, Effects, paragraph 36, page 386, (1972).
17. SAUDY, J.W., "Population heterogeneity hypothesis on radiation induced cancer", Health Physics, Vol. 25, 97, (1973).
18. "Symposium on information theory in biology" (Eds. Yockey, E.P., Platzman, R.L., and Quastler, H.) Pergamon Press, London and New York, (1958).
19. FISHER, R.A., "Statistical Information", Information Theory in Biology, (Ed. Quastler, H.), University of Illinois Press, Urbana, (1953).
20. BARTLETT, M.S., "Probability, statistics and time", Chapman and Hall, London, (1975).

#### ACKNOWLEDGEMENTS

I would like to acknowledge the generous support of this work by the Central Electricity Generating Board of Great Britain, including computing and other facilities made available at their Berkeley Nuclear Laboratories. I also wish to thank my colleague, Roger Clarke, for permission to include results of our joint investigations. We hope to publish a more extensive account in the near future.

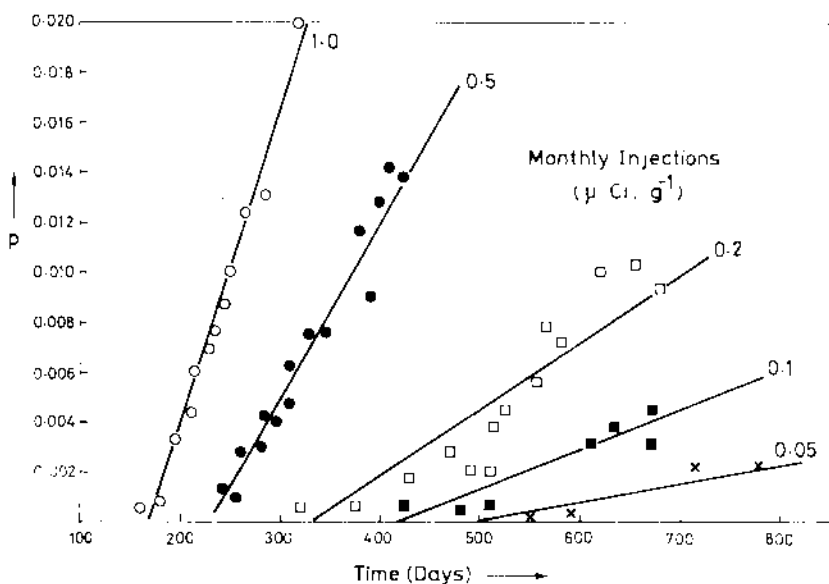

FIG.1 Probability of an Osteosarcoma in Mice (Per Animal Per Day) (Brues, 1949)

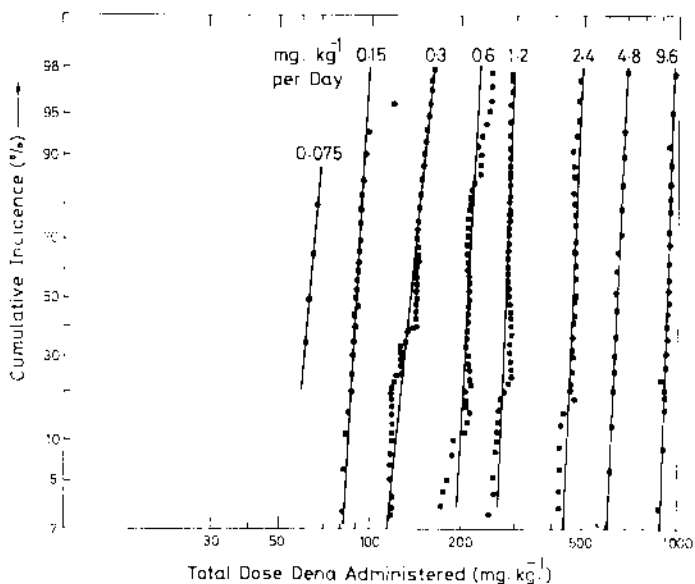

FIG.2 Dose-Response Curve for Diethylnitrosamine (DENa) in Rats (Druckrey, 1967)

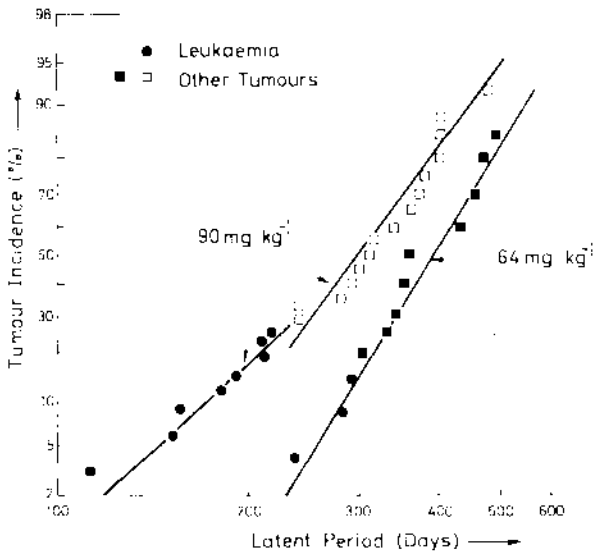

FIG.3 Carcinogenesis Induced by a Single Dose of Methyl-Nitroso-Urea, Given Intravenously to Rats ( Druckrey, 1967)

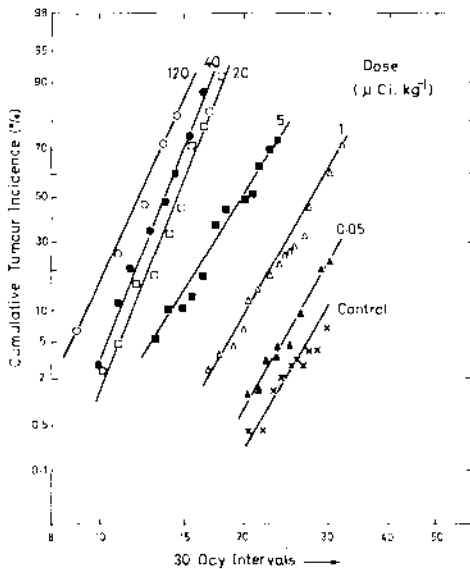

FIG.4 Cumulative Incidence of Osteosarcoma in Rats Following Single Injection of  $^{226}\text{Ra}$  (Albert and Altshuler, 1973)

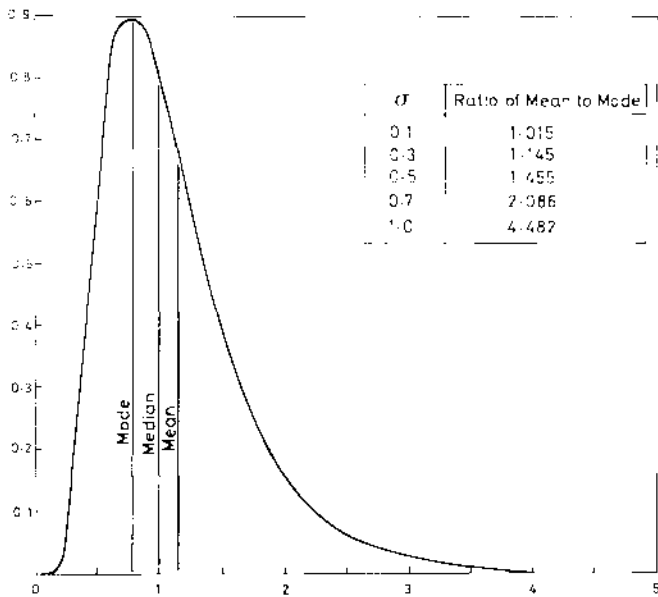

FIG.5 Features of the Log-Normal Distribution

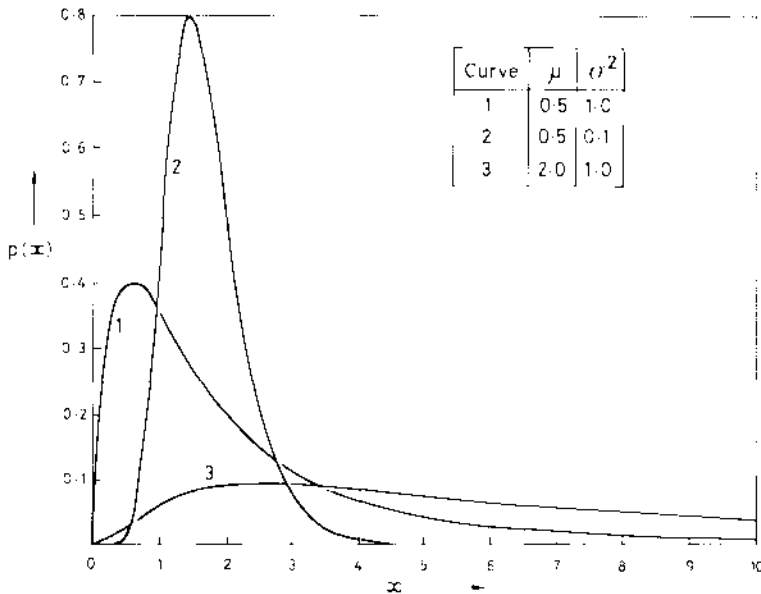

FIG.6 Examples of the Log-Normal Distribution

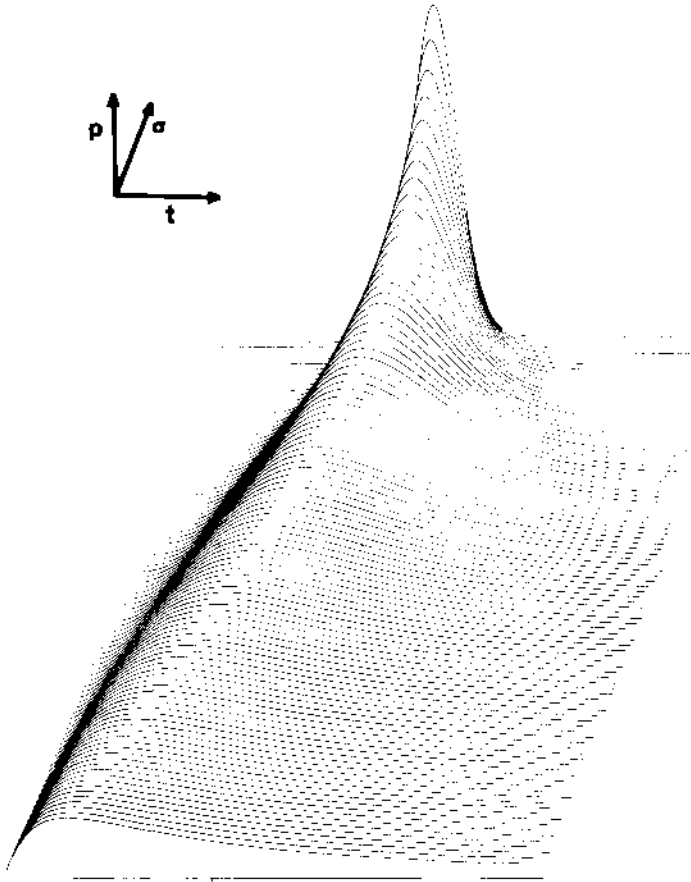

FIGURE 7: Log-normal probability density distribution with a constant median at 0.4 of the time scale and  $\sigma$  decreasing linearly from 1.0 (front) to 0.1 (back).

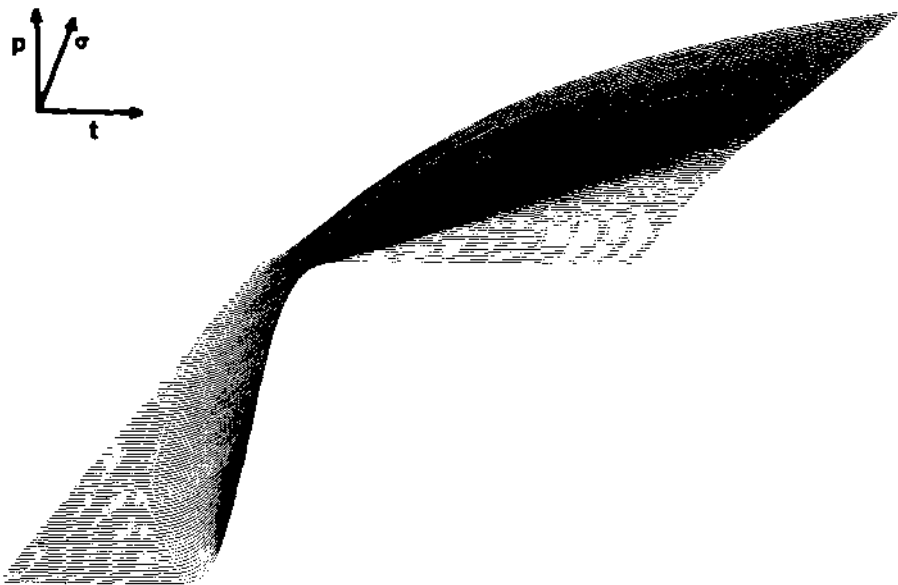

FIGURE 8: Integrated log-normal probability density distribution with constant median at 0.4 of the time scale and  $\sigma$  increasing linearly from 0.1 (front) to 1.0 (back).

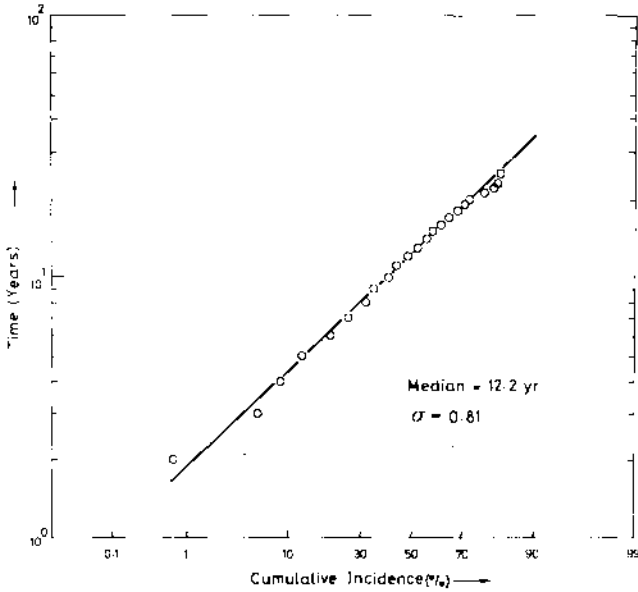

FIG.9 Incidence of Leukaemia Among Japanese Survivors from Hiroshima and Nagasaki

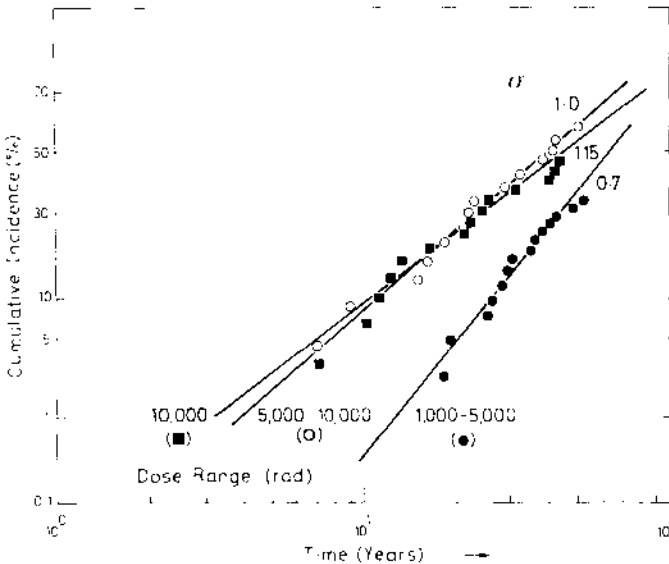

FIG.10 Incidence of Tumours in Radium Dial Painters, by Dose Received

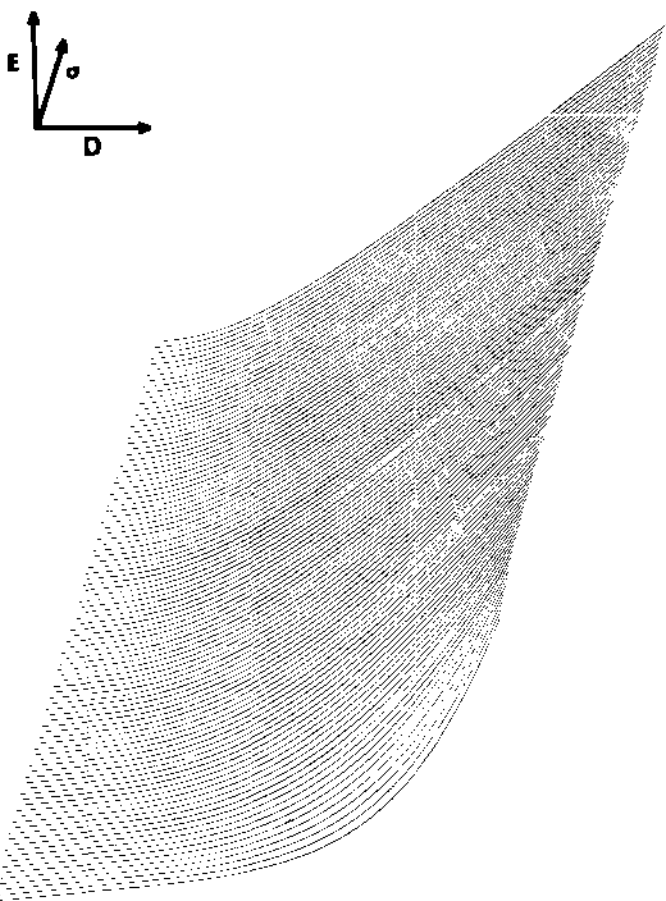

FIGURE 11: Cumulative probability curve derived assuming log-normal time of appearance of effect, that response is directly proportional to dose, and that median time reduces linearly with increasing dose by 30% over the dose range. The results show that if  $\sigma$  is essentially constant at a value of 0.1 (front), a fourth power law dose-response relationship arises.  $\sigma$  is allowed to increase linearly with increasing dose and as the range of  $\sigma$  increases the power law decreases until when  $\sigma$  varies from 0.1 to 1.0 (back) the dose response relationship becomes a square law.



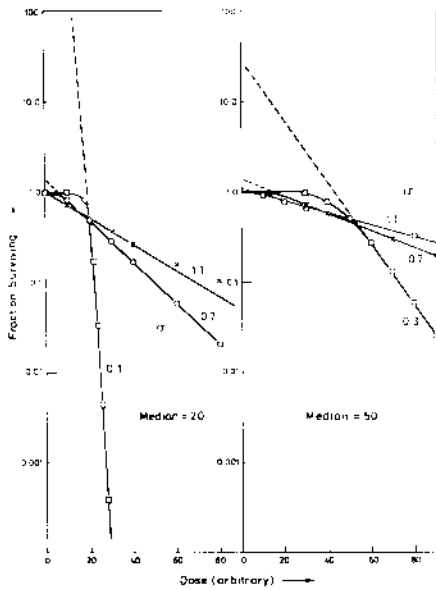

FIG.12 Survival Curves for Log-Normal Distribution of Cell Killing with Dose

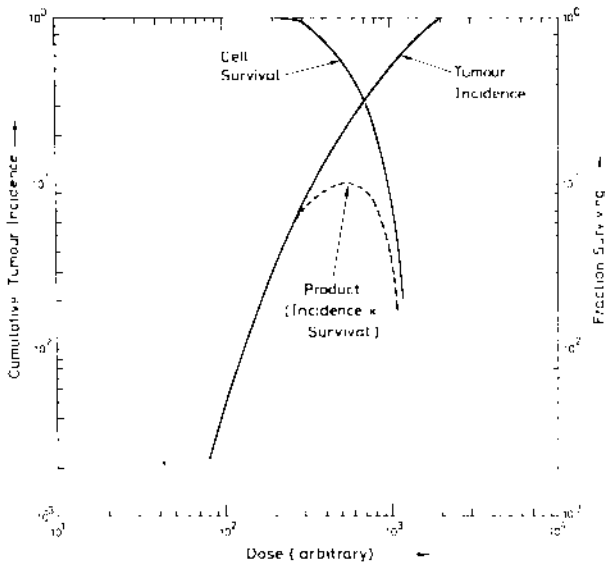

FIG.13 Hypothetical Dose-Response Curve, Generated Using Log-Normal Distributions of Incidence with Time and Cell Survival with Dose

## Notes

## Notes

## Notes



**ASSOCIATION INTERNATIONALE DE RADIOPROTECTION  
INTERNATIONAL RADIATION PROTECTION ASSOCIATION**

**IV<sup>e</sup> CONGRÈS INTERNATIONAL  
IVth INTERNATIONAL CONGRESS**

**RECUEIL  
DES COMMUNICATIONS**

---

**PROCEEDINGS**

---

**PARIS 24-30 AVRIL 1977**

## TABLE GENERALE DES MATIERES

	Page
Avertissement de l'éditeur	IV
Editor's foreword	V
Index des séances	VI
Session index	IX
Index des auteurs	XIII
Index des communications	XXVII
TOME 1 - Communications du lundi 25 avril	
Séances * : S 01, S 03, S 04, S 06, S 10	
P 1	
TOME 2 - Communications du mardi 26 et du mercredi 27 avril	
Séances * : S 02, S 05, S 07, S 08, S 09, S 11, S 12, S 26, S 27, S 13, S 15	
P 2A, P 2B, P 2C, P 3A, P 3B	
TOME 3 - Communications du jeudi 28 avril	
Séances * : S 16, S 17, S 18, S 19, S 20, S 21, S 22	
P 4A, P 4B, P 4C, P 5	
TOME 4 - Communications du vendredi 29 avril	
Séances * : S 14, S 23, S 24, S 25, S 28, S 29, S 30,	
P 6, P 7	

LA CONFERENCE SIEVERT : "The time factor in carcinogenesis" prononcée par le professeur MAYNEORO le lundi 25 Avril 1977 figure dans le tome 4, page 1421.

- \* Pour plus de détails sur le contenu et le déroulement des séances, se reporter à l'index des séances, page VI

## GENERAL SUMMARY

	Page
Avertissement de l'éditeur	IV
Editor's foreword	V
Index des séances	VI
Session index	IX
Author index	XIII
Paper index	XXVII

## VOLUME 1 - Papers presented on Monday April 25th

Sessions \* : S 01, S 03, S 04, S 06, S 10,  
P 1

## VOLUME 2 - Papers presented on Tuesday April 26th and Wednesday April 27th

Sessions \* : S 02, S 05, S 07, S 08, S 09, S 11, S 12, S 26, S 27, S 13, S 15,  
P 2A, P 2B, P 2C, P 3A, P 3B

## VOLUME 3 - Papers presented on Thursday April 28th

Sessions \* : S 16, S 17, S 18, S 19, S 20, S 21, S 22  
P 4A, P 4B, P 4C, P 5

## VOLUME 4 - Papers presented on Friday April 29th

Sessions \* : S 14, S 23, S 24, S 25, S 28, S 29, S 30,  
P 6, P 7

THE SIEVERT LECTURE : "The time factor in carcinogenesis" delivered by professor MAYNEORD on Monday April 25th 1977 is included in volume 4, page 1421.

\* For more information about sessions content and planning, please see session index, page IX

## AVERTISSEMENT DE L'ÉDITEUR

Le Recueil des Communications du 4ème Congrès International de l'AIIRP comprend les textes des communications à présenter lors du Congrès. Les communications sont reproduites dans leur langue originale et sans aucune correction d'édition.

Le procédé de reproduction photographique ne permet pas une impression parfaitement harmonieuse. Toutefois nous espérons avoir reproduit chaque communication aussi nette et lisible que la copie reçue de l'auteur le permettait.

Les communications sont réparties en quatre tomes, chaque tome comprenant les communications présentées pendant l'un des jours du Congrès. Le volume 2 réunit les communications du Mercredi à celles du Mardi.

Dans chaque tome les communications sont groupées par séance, les séances se succédant dans l'ordre chronologique et selon les numéros des salles pour les séances commençant à la même heure. Pour chaque séance les communications se succèdent dans leur ordre de présentation au cours de la séance.

Les communications dont les textes n'étaient pas parvenus au Secrétariat Général en temps utile pour être publiés sont indiquées "N.A." (non available). Toutefois elles continuent à figurer au programme et l'on espère qu'elles seront présentées en séance.

Les communications retirées par les auteurs avant la date de début d'impression ne sont pas mentionnées.

En tête de chaque tome se trouve une section d'information, la même dans chaque tome, et qui couvre les quatre tomes. Cette section comprend :

- table générale des matières
- liste des séances, classées par numéros croissants, indiquant pour chaque numéro de séance : le titre de la séance, le jour, l'heure, la salle, le tome et la page
- liste des auteurs, classés par ordre alphabétique, indiquant pour chaque auteur : le numéro de référence de la communication, la séance et le tome
- liste des communications, classées par numéros croissants, indiquant pour chaque communication la session, le volume et la page.

Des exemplaires supplémentaires de ce Recueil peuvent être achetés au prix de 150 FF pour les quatre volumes.

S'adresser à M. Gilbert BRESSON - Secrétaire Général  
4ème Congrès International de l'AIIRP  
B.P. n° 33 - 32260 FONTENAY AUX ROSES - FRANCE



## EDITOR'S FOREWORD

The Proceedings of the IRPA IVth International congress include the texts of the papers to be presented at the meeting. Papers are reproduced in their original language and without any editorial correction.

The photographic reproduction process does not permit a perfectly harmonious print. However we hope that every paper was reproduced as clean and legible as possible from the author's copy as received.

The papers are organized in four volumes, each volume covering papers presented during one given day of the meeting. Volume n° 2 includes Wednesday's papers together with Tuesday's.

In each volume, papers are arranged by sessions, the sessions being listed in chronological order, and by room numbers for sessions starting at the same time. Within each session the papers are listed in their order of presentation along the session.

The papers which did not reach the general secretariat in due time for printing are indicated as "N.A.", that is : non available. However they remain on the program and they hopefully will be presented at the said session.

Papers which were withdrawn by the authors before time of printing are not mentioned.

Each volume is headed by an information section, which is the same in each volume and covers all four volumes. This section includes :

- general summary table
- index of sessions, sorted in ascending sessions numbers, showing for each session number : the title of the session, the day, the time, the room, the volume and the page
- index of authors, sorted in alphabetical order, showing for each author : the paper number, the session and the volume
- index of papers, sorted in ascending numbers, showing for each paper : the session, the volume and the page.

Extra copies of these Proceedings may be purchased at the cost of 150 FF for the four volumes.

*Please apply to Mr. Gilbert BRESSON - General Secretary  
IRPA IVth International Congress  
B.P. n° 33 - 92260 FONTENAY AUX ROSES - FRANCE*

## INDEX DES SEANCES

S : séance orale  
 P : séance par affiche  
 BL : salle bleue

## SEANCES ORALES

SEANCE	JOUR-HEURE	SALLE	TITRE	TOME-PAGE
S 01	Lundi 25 14 h 15	BL	Aspects généraux de la protection contre les rayonnements (1ere partie)	1 - 1
S 02	Mardi 26 9 h 00	BL	Niveaux d'activité dans l'environnement et doses résultant des installations nucléaires. Limitation et contrôle des rejets (1ere partie)	2 - 233
S 03	Lundi 25 14 h 15	33	Aspects généraux de la dosimétrie et techniques de mesure	1 - 57
S 04	Lundi 25 16 h 30	BL	Comparaison des risques dus aux rayonnements avec les autres risques	1 - 171
S 05	Mardi 26 16 h 30	BL	Etudes de radioécologie	2 - 611
S 06	Lundi 25 16 h 30	32	Radiobiologie moléculaire et cellulaire	1 - 207
S 07	Mardi 26 9 h 00	33	Rayonnements non ionisants (AIRP)	2 - 309
S 08	Mardi 26 14 h 15	BL	Aspects généraux de la protection contre les rayonnements (2ème partie)	2 - 429
S 09	Mardi 26 14 h 15	32	Evaluation des doses aux organes	2 - 455
S 10	Lundi 25 14 h 15	32	Surveillance de l'exposition du personnel (1ere partie)	1 - 37
S 11	Mardi 26 14 h 15	33	Radioprotection du personnel dans les installations (1ere partie)	2 - 505
S 12	Mardi 26 9 h 00	32	Gestion des déchets radioactifs	2 - 279
S 13	Mercredi 27 9 h 00	BL	Les nouvelles recommandations de la CIPR; présentation et discussion	2 - 679
S 14	Vendredi 29 10 h 45	BL	Radioprotecteurs	4 -1287
S 15	Mercredi 27 10 h 45	BL	Rapport d'activité de la CIUR; table ronde sur les unités S.I.	2 - 681
S 16	Jeudi 28 9 h 00	BL	Doses collectives résultant de l'utilisation des rayonnements ; évaluations de l'UNSCEAR	3 - 631

SEANCE	JOUR-HEURE	SALLE	TITRE	TOME-PAGE
S 17	Jeudi 28 9 h 00	32	Effets des rayonnements sur l'homme, estimation des risques	3 - 707
S 18	Jeudi 28 9 h 00	33	Radioprotection du personnel dans les installations (3ème partie)	3 - 730
S 19	Jeudi 28 10 h 45	BL	Irradiation médicale (1ere partie)	3 - 569
S 20	Jeudi 28 14 h 15	BL	Niveaux d'activité dans l'environnement et doses résultant des installations nucléaires. Limitation et contrôle des rejets (2eme partie)	3 - 908
S 21	Jeudi 28 14 h 15	32	Accidents d'irradiation et accidents nucléaires; plans d'urgence	3 - 959
S 22	Jeudi 28 14 h 15	33	Irradiations produites par les sources naturelles et les biens de consommation	3 - 1007
S 23	Vendredi 29 9 h 00	BL	Critères de base pour la limitation des rejets radioactifs dans l'environnement: recommandations du Comité Technique de l'AIEA, présentation et discussion	4 - 1131
S 24	Vendredi 29 9 h 00	32	Radiobiologie expérimentale (1ere partie)	4 - 1141
S 25	Vendredi 29 9 h 00	33	Aspects médicaux de la protection contre les rayonnements	4 - 1181
S 26	Mardi 26 10 h 45	32	Contamination interne : modèles de dépôt et études métaboliques (1ere partie)	2 - 408
S 27	Mardi 26 16 h 30	33	Radioprotection du personnel dans les installations (2ème partie)	2 - 649
S 28	Vendredi 29 14 h 15	32	Radiobiologie expérimentale (2ème partie): carcinogénèse)	4 - 1319
S 29	Vendredi 29 14 h 15	33	Enseignement et information du public	4 - 1349
S 30	Vendredi 29 14 h 15	BL	Présentation par l'OMS des implications sanitaires de la production d'énergie	4 - 1317

## SEANCES PAR AFFICHE

SEANCE	JOUR-HEURE	SALLE	TITRE	TOME-PAGE
P 1	Lundi 25 14 h 15	35	Instruments et techniques de mesure	1 - 109
P 2	Mardi 26 9 h 00	35	a) Surveillance de l'exposition du personnel (2ème partie) b) Ecran de protection c) Exposition du personnel dans les applications médicales des rayonnements.	2 - 341 371 383
P 3	Mardi 26 14 h 15	35	a) Aspects physiques de la dosimétrie b) Diffusion atmosphérique des rejets radioactifs, doses résultantes	2 - 523 567
P 4	Jeudi 28 9 h 00	35	a) Contrôle d'ambiance et d'environnement. b) Spectrométrie des neutrons c) Mesure des retombées	3 - 783 821 839
P 5	Jeudi 28 14 h 15	35	Irradiation médicale (2ème partie)	3 -1085
P 6	Vendredi 29 9 h 00	35	Techniques nouvelles de mesure	4 -1227
P 7	Vendredi 29 14 h 15	35	Contamination interne : modèles de dépôt et études métaboliques (2ème partie)	4 -1381

## SESSION INDEX

S : oral session  
 P : poster session  
 BL : salle bleue

## ORAL SESSION

SESSION	DAY-TIME	ROOM	TITLE	VOLUME-PAGE
S 01	Monday 25 th 2.15 pm	BL	General aspects of radiation protection (part 1)	1 - 7
S 02	Tuesday 26 th 9.00 am	BL	Environmental levels and doses resulting from nuclear activities. Limitation and control of releases (part 1)	2 - 233
S 03	Monday 25 th 2.15 pm	33	General aspects of dosimetry and techniques of measurement	1 - 57
S 04	Monday 25 th 4.30 pm	BL	Radiation hazards in comparison with other hazards.	1 - 171
S 05	Tuesday 26 th 4.30 pm	BL	Radioecological studies	2 - 611
S 06	Monday 25 th 4.30 pm	32	Molecular and cellular radiobiology	1 - 307
S 07	Tuesday 26 th 9.00 am	33	Non ionizing radiation (IRPA)	2 - 309
S 08	Tuesday 26 th 2.15 pm	BL	General aspects of radiation protection (part 2)	2 - 429
S 09	Tuesday 26 th 2.15 pm	32	Assessment of organ doses	2 - 455
S 10	Monday 25 th 2.15 pm	32	Personnel monitoring (part 1)	1 - 31
S 11	Tuesday 26 th 2.15 pm	33	Occupational radiation protection (part 1)	2 - 405
S 12	Tuesday 26 th 9.00 am	32	Radioactive waste management	2 - 279
S 13	Wednesday 27 th 9.00 am	BL	The new ICRP recommendations : presentation and discussion	2 - 675
S 14	Friday 29 th 10.45 am	BL	Radioprotectors	4 - 1237
S 15	Wednesday 27 th 10.45 am	BL	Report on ICRU activities ; round table on S.I. units	2 - 681

SESSION	DAY-TIME	ROOM	TITLE	VOLUME-PAGE
S 16	Thursday 28 th 9.00 am	BL	Collective doses from practices involving radiation exposures ; UNSCEAR assessment	3 - 697
S 17	Thursday 28 th 9.00 am	32	Effects of radiation in man ; risk estimates	3 - 701
S 18	Thursday 28 th 9.00 am	33	Occupational radiation protection (part 3)	3 - 739
S 19	Thursday 28 th 10.45 am	BL	Medical irradiation (part 1)	3 - 859
S 20	Thursday 28 th 2.15 pm	BL	Environmental levels and doses resulting from nuclear activities. Limitation and control of releases (part 2)	3 - 903
S 21	Thursday 28 th 2.15 pm	32	Radiation and nuclear accidents, emergency plans	3 - 959
S 22	Thursday 28 th 2.15 pm	33	Irradiation from natural sources and consumer products	3 - 1007
S 23	Friday 29 th 9.00 am	BL	Basic criteria for the limitation of radioactive releases into the environment : IAEA technical advisory committee recommendations, presentation and discussion	4 - 1131
S 24	Friday 29 th 9.00 am	32	Experimental radiobiology (part 1)	4 - 1141
S 25	Friday 29 th 9.00 am	33	Medical aspects of radiation protection	4 - 1181
S 26	Tuesday 26 th 10.45 am	32	Deposition models and metabolic studies of internal contamination (part 1)	2 - 403
S 27	Tuesday 26 th 4.30 pm	33	Occupational radiation protection (part 2)	2 - 849
S 28	Friday 29 th 2.15 pm	32	Experimental radiobiology (part 2 : carcinogenesis)	4 - 1319
S 29	Friday 29 th 2.15 pm	33	Education training and public information	4 - 1349
S 30	Friday 29 th 2.15 pm	BL	Presentation by WHO of health implications of energy production	4 - 1317

## POSTER SESSION

SESSION	DAY-TIME	ROOM	TITLE	VOLUME-PAGE
P 1	Monday 25 th 2.15 pm	35	Instruments and techniques of measurement.	1 - 103
P 2	Tuesday 26 th 9.00 am	35	a) Personnel monitoring (part 2) b) Shielding c) Occupational exposure in the medical uses of radiation	2 - 341 371 333
P 3	Tuesday 26 th 2.15 pm	35	a) Physical aspects of dosimetry b) Atmospheric dispersion of radioactive releases and resulting doses	2 - 323 327
P 4	Thursday 28 th 9.00 am	35	a) Area and environmental monitoring techniques b) Neutron spectrometry c) Fall out measurements	3 - 723 821 833
P 5	Thursday 28 th 2.15 pm	35	Medical irradiation (part 2)	3 - 1025
P 6	Friday 29 th 9.00 am	35	New techniques of measurements	4 - 1227
P 7	Friday 29 th 2.15 pm	35	Deposition models and metabolic studies of internal contamination (part 2)	4 - 1227

## INDEX DES AUTEURS

## AUTHOR INDEX

(Nom, communication n°, séance n°, tome n°)

(Name, paper n°, session n°, volume n°)

- AARKROG A., 138, P4c, 3  
 ABERG L., 416, P5, 3  
 AGRAFIOTIS D., 425, S29, 4  
 AGRAWAL M.S., 244, P5, 3  
 AIGINGER H., 371, P6, 4  
 AINSWORTH E.J., 229, S24, 4  
 AKOEV I.G., 234, S14, 4  
                   237, S24, 4  
 AL-BANNA N.S., 017, S22, 3  
 AL-HASHIMI S.A.M., 017, S22, 3  
 ALBERTAZZI O., 200, P1, 1  
 ALEINIKOV V.E., 214, P4b, 3  
                   401, P4b, 3  
 ALEKSEEVA L.V., 234, S14, 4  
 ALEKSIC B., 185, P2c, 2  
 ALONSO J.V.S., 040, P2b, 2  
 ANDERSEN B.V., 407, S08, 2  
 ANDRASI A., 318, S26, 2  
 ANNANMAKI M., 397, S22, 3  
 ANNO J., 393, P1, 1  
 APSIMON H.M., 403, P3b, 2  
 ARCHER B.R., 230, P5, 3  
 ASIKAINEN M., 397, S22, 3  
 ASQUITH J.C., 309, S06, 1  
 ATHALYE V., 391, S05, 2  
 ATHEY T.W., 304, S07, 2  
 AUXIER J.A., 335, S17, 3  
  
 BABOSCAY L., 094, S08, 2  
 BADIELLO R., 301, S06, 1  
 BAILLET P., 293, S27, 2  
 BAILEY E.D., 024, S21, 3  
  
 BAILLY H., 012, S18, 3  
 BAIR W.J., 103, S17, 3  
 BALLADA J., 358, S21, 3  
 BAMBLEVSKY V.P., 214, P4b, 3  
 BARKE R., 209, P5, 3  
 BARKHUDAROV R.M., 410, S04, 1  
 BARTONICK B., 372, S21, 3  
 BARZIC J.Y., 386, S18, 3  
 BASSI P., 418, S07, 2  
 BAUM J.W., 467, S17, 3  
 BAZOGE A., 166, S03, 1  
 BEAU P., 358, S21, 3  
                   359, S21, 3  
                   361, P7, 4  
 BECKER K., 026, S08, 2  
 BECKOLS R., 352, S05, 2  
 BELL K., 201, P7, 4  
 BENASSAI S., 195, P5, 3  
 BENGTSSON G., 416, P5, 3  
 BENINSON D., 515, S16, 3  
 BENKO L., 340, P6, 4  
 BENNELICK E.J., 038, S29, 4  
 BENWELL D.A., 130, S07, 2  
 BERGMAN C., 255, S11, 2  
 BERGMAN K., 416, P5, 3  
 BERGMAN R., 294, P3b, 2  
 BERGMANN F., 379, S03, 1  
 BHAT I.S., 124, S18, 3  
 BHOLA G.C., 032, P3a, 2  
 BIAU A., 337, S10, 1  
 BINGO K., 119, P1, 1  
 BIRO T., 340, P6, 4  
 BITTEL R., 016, S04, 1



- BLANCHARD Ph., 163, P6, 4  
 BLOMGREN P.G., 416, P5, 3  
 BONKA H., 280, S20, 3  
     281, S20, 3  
 BOOK S.A., 219, S09, 2  
 BORAK T.D., 229, S24, 4  
 DORY P., 377, P1, 1  
 BOSEMAN J., 333, S25, 4  
 BOULENGER R., 113, S22, 3  
 BOURGUIGNON M., 435, S25, 4  
 BOUVILLE A., 351, S22, 3  
     352, S05, 2  
 BOVARD P., 392, S02, 2  
 HOZOKY L., 300, S11, 2  
 BRADLEY F.J., 398, P2a, 2  
 BRENNAN P.C., 229, S24, 4  
 BRENK H.D., 278, S20, 3  
 BRESLER S.E., 383, S14, 4  
 BREUER F., 154, S18, 3  
 BRIERE J., 444, S19, 3  
 BROERSE J.J., 355, P4b, 3  
 BROSEY M.H., 279, S12, 2  
 BROSSON M., 463, S29, 4  
 BROWN L.D., 350, P1, 1  
 BRUNNER H., 157, S03, 1  
 BRUSSERMANN K., 278, S20, 3  
     281, S20, 3  
 BUBENIKOVA D., 264, S28, 4  
 BUCHAN G., 414, P6, 4  
 BUDD T., 307, P6, 4  
 BUREAU M., 293, S27, 2  
 BURGHKARDT B., 338, P6, 4  
 BUSHONG S.C., 230, P5, 3  
 BUSUOLI G., 379, S03, 1  
     418, S07, 2  
 BUTTON J.C.E., 036, S21, 3  
 CALDER S.E., 333, S25, 4  
 CAPPELLINI L., 358, S21, 3  
 CARDINALE A., 110, S18, 3  
 CARTER L.A., 407, S08, 2  
 CARTER M.W., 441, S20, 3  
     442, P4a, 3  
 CASKEY D.W., 065, S22, 3  
 CASTELNAU L., 437, S24, 4  
 CASTREN O., 397, S22, 3  
 CHAKRABORTY S., 282, P3b, 2  
     100, P3b, 2  
 CHALABREYSSE J., 251, S04, 1  
     252, S10, 1  
 CHAMBERLAIN J., 105, P6, 4  
 CHAMEAUD J., 342, S28, 4  
 CHANDRAMOULI S., 124, S18, 2  
 CHARTIER J.L., 166, S03, 1  
 CHARY J., 357, P3a, 2  
 CHEMTOB M., 355, P4b, 3  
     357, P3a, 2  
 CHENAULT R., 163, P6, 4  
 CHIRKOV Y.Y., 222, S14, 4  
 CHITZHOV A.Y., 236, S14, 4  
 CHOU D.P., 186, P3b, 2  
 CHRISPIN A.R., 250, P5, 3  
 CHUITON R., 162, P1, 1  
 CHURCHILL W.C., 307, P6, 4  
 CLARKE R.H., 285, S12, 2  
     286, P3b, 2  
     287, S20, 3  
 CLEMENTE G.F., 154, S18, 3  
 CLEVELAND J.E., 091, P1, 1  
 CLOUTIER R.J., 208, S09, 2  
 CLUCHET J., 241, S12, 2  
 COHEN M.O., 476, S09, 2  
 COLARD J., 113, S22, 3  
 COOK L.M., 065, S22, 3  
 CORBETT J.O., 289, S21, 3  
 CORDOVA H.I., 446, P4a, 3  
 CORLEY J.P., 177, S20, 3

- COULON R., 352, S05, 2  
 COURTAULT J., 242, S12, 2  
 COVEART A.S., 174, P4a, 3  
 COVELL D.F., 446, P4a, 3  
 CRAIG A.G., 141, S06, 1  
 142, S06, 1  
 CRAWLEY F.E.H., 070, S26, 2  
 CREGUT A., 466, S18, 3  
 CROSS W.G., 172, P2b, 2  
 CROUSE D.A., 229, S24, 4  
 CSAKY L., 303, S25, 4  
 CURATOLO M., 195, P5, 3  
 CZERSKI P., 523, S07, 2
- DABURON M.L., 358, S21, 3  
 DABURON F., 438, S24, 4  
 DAGLE G.E., 374, S28, 4  
 DALE E., 363, P5, 3  
 DANILOVIC D., 382, S03, 1  
 DE COSNAC B., 434, P6, 4  
 DELARMINAT E., 425, S29, 4  
 DELFORGE J., 037, S17, 3  
 DELMAS J., 391, S05, 2  
 DELPLA M., 428, S01, 1  
 DESCOURS S., 153, P4a, 3  
 DESPRES A., 354, P3b, 2  
 DEWORM J.F., 339, S18, 3  
 RJUKIC Z., 185, P2c, 2  
 ROBICI F., 195, P5, 3  
 ROLOY M.T., 435, S25, 4  
 DONAGI A., 258, P2a, 2  
 263, P5, 3  
 DORSCHER B., 214, P4b, 3  
 DOUGLAS J.A., 307, P6, 4  
 DREXLER G., 292, S09, 2  
 DUCATEZ G., 435, S25, 4  
 DUFTSCHMID K.E., 156, P3a, 2  
 DUMONT G., 339, S18, 3
- DUPORT Ph., 162, P1, 1  
 385, P2a, 2  
 386, S18, 3  
 387, P7, 4  
 DUTT G.C., 130, S07, 2  
 DVORAK V., 264, S28, 4
- EDELHAUSER H., 280, S20, 3  
 EGGERT S., 524, S07, 2  
 EHANTI D.P., 462, P3a, 2  
 EICKELPASCH N., 188, S27, 2  
 ELLIS R.E., 516, S19, 3  
 ERATH W., 371, P6, 4  
 ERLENDACH H.R., 284, P2a, 2  
 ERMOLAEVA A.P., 490, S01, 1  
 ERRE N., 302, S09, 2  
 ESCARIEUX E., 393, P1, 1  
 ESPOSITO A., 422, P2a, 2  
 ETTINGER K.V., 413, P6, 4  
 414, P6, 4  
 EVTODIENKO Y.V., 235, S06, 1
- FABER M., 521, S07, 2  
 FAGNANI F., 427, S18, 3  
 FAILLA L., 330, S04, 1  
 FEHER I., 318, S26, 2  
 FEIGE Y., 258, P2a, 2  
 261, S09, 2  
 FELDMANN K.L., 305, S01, 1  
 FIEUW G., 339, S18, 3  
 FILIPY R.E., 374, S28, 4  
 FINCK R.R., 128, P4a, 3  
 FISCHER D.R., 333, S25, 4  
 FITZGERALD M., 250, P5, 3  
 253, S09, 2  
 FLAKUS F.N., 484, S03, 1  
 FLEISCHMANN A.W., 036, S21, 3  
 FLUHR H., 526, P2b, 2

- FORD M.R., 313, S09, 2  
 FRAIZLER A., 389, S02, 2  
 FRANK M.L., 295, S05, 2  
 FRIEDMAN L.F., 270, P4b, 3  
 FRIEDRICH W., 006, P2b, 2  
 FRISCHAUF H., 245, S19, 3  
 FRITSCH P., 342, S28, 4  
 FROSSARD H., 358, S21, 3  
 359, S21, 3  
 FRY F.A., 057, S09, 2  
 058, P3a, 2  
 FRY R.J.M., 229, S24, 4  
 FUJITA M., 116, P3a, 2  
 FUKUI M., 193, S05, 2
- GAINES M.J., 086, S29, 4  
 GANASSI E.E., 239, S14, 4  
 GANDON R., 388, S02, 2  
 GANIVET M., 012, S18, 3  
 GARCET M., 358, S21, 3  
 GARG S.P., 462, P3a, 2  
 GARNIER A., 151, S20, 3  
 GADDIAU J., 481, P1, 1  
 GEMENETZIS E., 158, S25, 4  
 GENEST L., 433, S24, 4  
 437, S24, 4  
 GERDT V.P., 401, P4b, 3  
 GHOSH S.K., 130, S07, 2  
 GIBSON J.A.B., 306, P1, 1  
 309, S06, 1  
 GILEADI A.E., 476, S09, 2  
 GLAZE S.A., 230, P5, 3  
 GODDARD A.J.H., 403, P3b, 2  
 GOLCHERT N.W., 049, P4c, 3  
 GOLTZ S., 524, S07, 2  
 GONCHARENKO E.N., 222, S14, 4  
 GONEN Y.G., 364, S21, 3  
 GONGORA R., 457, S21, 3  
 GORIN G., 301, S06, 1
- GRADOWSKI K., 432, P2a, 2  
 GRANDOLFO M., 485, S07, 2  
 GRALBY A., 391, S05, 2  
 392, S02, 2  
 GREBENEV V.N., 412, P1, 1  
 GREEN B.M.R., 057, S09, 2  
 GREEN D., 518, S26, 2  
 GRONBERG T., 063, S09, 2  
 GROS R., 358, S21, 3  
 GROSS R.E., 449, P5, 3  
 GROVE G., 104, S19, 3  
 GUARY J.C., 389, S02, 2  
 GUEGUENIAT P., 388, S02, 2  
 GUERIN P., 153, P4a, 3  
 GUEZENGAR J.M., 351, S22, 3  
 GUILLET H., 012, S18, 3  
 GUIMOND R.J., 109, S22, 3  
 GUPTA M.M., 032, P3a, 2  
 GUSEV D.I., 408, S01, 1  
 409, S20, 3  
 GUSEV N.G., 409, S20, 3  
 GYLLANDER C., 294, P3b, 2
- HADDAD A., 153, P4a, 3  
 HAFEZ M.B., 018, S25, 4  
 HAFEZ N., 018, S25, 4  
 HAHN G., 216, P2b, 2  
 HAKANEN M., 202, P4c, 3  
 HALM A., 472, S19, 3  
 HALPERIN J.A., 104, S19, 3  
 HAM G.J., 062, P7, 4  
 HAMILTON D.R., 420, P5, 3  
 HANKIN N.N., 304, S07, 2  
 HANKINS D.E., 114, P3a, 2  
 HARDUIN J.C., 358, S21, 3  
 359, S21, 3  
 HARIDASAN T.K., 462, P3a, 2

- HARRANEK Ch., 370, P5, 3  
 HARRISON N.T., 311, S21, 3  
 HARTE G.A., 285, S12, 2  
 HARVEY J.R., 102, S03, 1  
 HASL G., 044, P5, 3  
 HASSENSTEIN E., 150, P5, 3  
 HETNZELMANN M., 246, P1, 1  
 HERBAUT Y., 377, P1, 1  
 HERSTEL W., 248, P5, 3  
 HESSEL D., 280, S20, 3  
 HETHERINGTON J.A., 179, S20, 3  
 HILL H.W., 136, S02, 2  
 HILL M.D., 055, S22, 3  
 HIPKIN J., 107, P2a, 2  
 HLADKY E., 372, S21, 3  
 HOFERT M., 291, S03, 1  
 HOFMANN W., 187, S09, 2  
 HOGEWEG B., 355, P4b, 3  
 HOLEMAN G.R., 270, P4b, 3  
 HOLLINS J.G., 411, S22, 3  
 HOLM E., 085, P4c, 3  
 HOLMBERG P., 233, P1, 1  
 HOLT P.D., 309, S06, 1  
 HOLTZMAN R.D., 093, P7, 4  
 HOLZAPFEL G., 167, P6, 4  
 HONDA Y., 131, S05, 2  
 HOTZL H., 341, S02, 2  
 HOWELLS G.R., 518, S26, 2  
 HOWLAND W.J., 363, P5, 3  
 HULL A.P., 227, S01, 1  
 HUNT G.J., 059, S22, 3  
 HWANG J.M.L., 335, S 17, 3  
 HYKES D.L., 363, P5, 3  
 HYVONEN M., 233, P1, 1  
 ILYIN L.A., 410, S04, 1  
 ILCEWICZ F.H., 093, P7, 4  
 INDOVINA P.L., 195, P5, 3  
 ING H., 172, P2b, 2  
 INGRAM D., 253, S09, 2  
 TRHWECK K., 145, P4c, 3  
 ISRAELI M., 258, P2a, 2  
 ITAKURA N., 192, P4a, 3  
 ITIE C., 166, S03, 1  
 IYER P.S., 183, S21, 3  
 JAAKKOLA T., 202, P4c, 3  
 205, P4c, 3  
 JACOBI W., 511, S09, 2  
 JACQUEMIN M., 466, S18, 3  
 JAMMET H., 457, S21, 3  
 JAN P., 135, S03, 1  
 JAMES D.E., 304, S07, 2  
 JANKOWSKI J., 083, P5, 3  
 JARDINE G.C., 311, S21, 3  
 JARVELA G.L., 447, P7, 4  
 JEANMAIRE L., 358, S21, 3  
 JEANSON P., 293, S27, 2  
 JEFFERIES D.F., 179, S20, 3  
 JESCHKI W., 094, S08, 2  
 JOHNSON C.J., 067, S02, 2  
 JOHNSON D.W., 149, P5, 3  
 JOHNSON R.G., 363, P5, 3  
 JOHNSON W.S., 068, P3a, 2  
 JONES A., 398, P2a, 2  
 JONES A.R., 171, P4a, 3  
 JONES T.D., 335, S17, 3

- KAISER G.D., 060, P3b, 2  
 KANNAN A., 183, S21, 3  
 KAPOOR K.K., 032, P3a, 2  
 KARLBERG O., 294, P3b, 2  
 KATOH K., 223, P7, 4  
 KATSURAYAMA K., 192, P4a, 3  
 193, S05, 2  
 KAWAI H., 159, P6, 4  
 KEINONEN M., 202, P4c, 3  
 KELLER J.H., 184, S02, 2  
 KELLY R., 398, P2a, 2  
 KERR G.D., 335, S17, 3  
 KHADEMI B., 455, S22, 3  
 KHAN A.H., 125, S10, 1  
 KHOCHTINAT N., 434, P6, 4  
 KHORTSEV A.V., 380, S17, 3  
 KLEFER H., 232, S29, 4  
 KILLDARDA M., 400, S24, 4  
 402, S25, 4  
 KIMURA Y., 131, S05, 2  
 KINOSHITA M., 276, P4c, 3  
 KINSELLA I.A., 010, S06, 1  
 KIRSCHMANN R., 113, S22, 3  
 391, S05, 2  
 KLENER V., 264, S28, 4  
 KLETTER K., 245, S19, 3  
 KNIEFER J., 006, P2b, 2  
 KNIGHT A., 057, S09, 2  
 058, P3a, 2  
 KNIZHNIKOV V.A., 410, S04, 1  
 KOBAL I., 473, P4a, 3  
 KOBAYASHI A., 131, S05, 2  
 KOCH G., 391, S05, 2  
 KOELZER W., 232, S29, 4  
 KOENIG B. 241, S12, 2  
 242, S12, 2  
 KOFRANEK V., 264, S28, 4  
 KOGA T., 159, P6, 4  
 KOMAROV E.J., 519, S30, 4  
 KOMNICK K., 006, P2b, 2  
 KOMOCHKOV M.M., 214, P4b, 3  
 401, P4b, 3  
 KONIG L.A., 298, S05, 2  
 299, S05, 2  
 KOSTIC S., 382, S03, 1  
 KOTELES G.J., 303, S25, 4  
 483, S05, 2  
 KOTRAPPA P., 124, S18, 3  
 462, P3a, 2  
 KRAGH P., 168, P6, 4  
 KRAMER R., 292, S09, 2  
 KRAUSS O., 404, P5, 3  
 KREGGER W.E., 316, S27, 2  
 KREPLER P., 370, P5, 3  
 KRISTAN J., 473, P4a, 3  
 KUBASOVA T., 303, S25, 4  
 KUBIK I., 372, S21, 3  
 KUDRYAVTZEVA A.A., 234, S14, 4  
 KUPFER J., 524, S07, 2  
 KUPRIANOVA V.M., 489, S04, 1  
 KUROKAWA Y., 276, P4c, 3  
 KUROSAWA R., 178, S10, 1  
 KUSAMA T., 155, S17, 3  
 KUSHELEVSKY A.P., 261, S09, 2  
 KUZIN A.M., 235, S06, 1  
 KYDRYASHOV Y.H., 222, S14, 4  
 LAFONTAINE A., 113, S22, 3  
 LAFUMA J., 342, S28, 4  
 343, S28, 4  
 344, S28, 4  
 346, S24, 4  
 LAKEY J.R.A., 332, S10, 1  
 LAMBINON Y., 463, S29, 4  
 LASSEUR C., 481, P1, 1  
 LAVIGNE B., 355, P4b, 3  
 357, P3a, 2

- LE GO A., 433, S24, 4  
 LE GO R., 433, S24, 4  
     434, P6, 4  
     435, S25, 4  
     437, S24, 4  
 LEBRUN J.C., 242, S12, 2  
 LECERF J., 525, S27, 2  
 LECONNETABLE J., 241, S12, 2  
 LE GRAND J., 354, P3b, 2  
 LENZ U., 218, S25, 4  
 LE PETIT J., 435, S25, 4  
 LERCH P., 134, S09, 2  
     135, S03, 1  
 LESER Y., 263, P5, 3  
 LEVAIN C., 455, S22, 4  
 LICHTER A., 263, P5, 3  
 LIDEN K., 128, P4a, 3  
 LIN C.Y., 186, P3b, 2  
 LINDELL H., 517, S23, 4  
 LINSLEY G.S., 072, S11, 2  
 LITAI D., 364, S21, 3  
 LLYOD R.D., 333, S25, 4  
 LORRAIN S., 164, P6, 4  
 LOVE D.L., 446, P4a, 3  
 LOVELESS B.W., 062, P7, 4  
 LOWDER W.M., 220, S03, 1  
 LUCCI F., 422, P2a, 2  
 MACCIA C., 426, S02, 2  
 MACDONALD H.F., 288, S21, 3  
 MADELAINE G., 386, S18, 3  
 MADELMONT C., 351, S22, 3  
     352, S05, 2  
 MADHIVANATH U., 182, S07, 2  
 MAEDA K., 247, P7, 4  
 MAGAUD G., 012, S18, 3  
 MAITRE P., 424, S21, 3  
     426, S02, 2  
     427, S18, 3  
 MALABRET J.L., 433, S24, 4  
     437, S24, 4  
 MALATOVA I., 264, S28, 4  
 MALCHI S., 258, P2a, 2  
 MAILLARD J.R., 413, P6, 4  
     414, P6, 4  
 MALONE J.P., 010, S06, 1  
     011, S14, 4  
 MANAKA R.C., 429, P7, 4  
 MARKOVIC B., 402, S25, 4  
 MARKOVIC P., 231, S25, 4  
 MARLEIN J., 339, S18, 3  
 MARSHALL M., 307, P6, 4  
 MARTIN J.J., 367, S20, 3  
 MARTONEN T.H., 201, P7, 4  
 MASHNEVA N.I., 489, S04, 1  
 MASSE R., 342, S28, 4  
     343, S28, 4  
     344, S28, 4  
     346, S24, 4  
 MATSUBARA J., 223, P7, 4  
     247, P7, 4  
 MAYNEORD W.V., page 1 421, 4  
 MAYS C.W., 333, S25, 4  
 MC FARLAND S.S., 333, S25, 4  
 MC DONALD K.E., 374, S28, 4  
 MC LEAN A.S., 095, S01, 1  
 MEDIONI R., 165, P6, 4  
     356, S03, 1  
 MEDVEDEV B.I., 235, S06, 1  
 MEHL J., 419, S22, 3  
 MEHTA S.C., 032, P3a, 2  
 MENOUX B., 361, P7, 4  
 MESLIN T., 424, S21, 3  
     427, S18, 3  
 METIVIER H., 342, S28, 4  
     343, S28, 4  
     344, S28, 4  
     346, S24, 4  
 MIDDELBOF V., 004, S29, 4  
 MIETTINEN J.K., 202, P4c, 3  
     205, P4c, 3

- MILIVOJEVIC K., 231, S25, 4  
MILLER F.L., 335, S17, 3  
MILLER K., 279, S12, 2  
MILLER R.W., 091, P1, 1  
MILLS W.A., 109, S22, 3  
MITCHELL N.T., 179, S20, 3  
MODAN B., 096, S17, 3  
MOGHISSI A.A., 441, S20, 3  
442, P4a, 3  
MOGHIMI D.J., 527, S20, 2  
MORGAN K.Z., 451, S01, 1  
MORIARTY M., 011, S14, 4  
MORIN M., 342, S28, 4  
343, S28, 4  
MORISHIMA H., 159, P6, 4  
MORLAT G., 425, S29, 4  
MORONI J.P., 337, S10, 1  
MULGREW S., 011, S14, 4  
MURTHY K.B.S., 122, P6, 4  
MURTHY M.S.S., 050, S04, 1  
MUSSALO H., 202, P4c, 3  
MUZDEKA S., 382, S03, 1
- NETCHEV Ch., 041, S26, 2  
NETTELAND O., 274, P2c, 2  
NEUMEISTER K., 210, S19, 3  
212, S29, 4  
NGUYEN V.D., 355, P4b, 3  
356, S03, 1  
NICOLAE M., 423, P6, 4  
NIEMISTO L., 205, P4c, 3  
NISHIWAKI Y., 131, S05, 2  
159, P6, 4  
NIWA T., 159, P6, 4  
NOEL J.P., 357, P3a, 2  
NOLIBE D., 342, S28, 4  
343, S28, 4  
344, S28, 4  
346, S24, 4  
NORDLUND G.G., 061, P3b, 2  
NOVAK D., 473, P4a, 3  
NOVAK L.J., 400, S24, 4  
NOWOTNY R., 245, S19, 3  
NUESSLIN F., 150, P5, 3
- O'CONNOR M.K., 011, S14, 4  
O'RIORDAN M.C., 058, P3a, 2  
059, S22, 3  
ODILON G., 358, S21, 3  
OHLMEYER M., 526, P2b, 2  
OKAMOTO K., 192, P4a, 3  
OLIVIER J.P., 512, S12, 2  
OPLADEN G., 246, P1, 1  
OREKHOV A.N., 222, S14, 4  
OSBORNE R.V., 173, P4a, 3  
174, P4a, 3  
175, S27, 2  
OSHINO M., 118, P1, 1  
OTTATI P., 110, S18, 3
- NAGARATNAM A., 032, P3a, 2  
NAGEL E., 100, P3b, 2  
283, S12, 2  
NAHARIN A., 260, S25, 4  
NAKASHIMA Y., 192, P4a, 3  
NATH R., 270, P4b, 3  
NAVE M., 263, P5, 3  
NEGRIENKO K.V., 489, S04, 1  
NEIDER R., 026, S08, 2  
NELSON I.C., 120, S02, 2  
NENOT J.C., 343, S28, 4  
358, S21, 3  
359, S21, 3  
361, P7, 4  
457, S21, 3

- PACHE G., 135, SO3, 1  
 PACYNA J.M., 029, P7, 4  
 PAGES J.P., 425, S29, 4  
 PAGES P., 424, S21, 3  
     426, SO2, 2  
     427, S18, 3  
 PAILHES A., 320, P1, 1  
 PAJOT J., 012, S28, 3  
 PALMER R.F., 374, S18, 4  
 PANOV D., 400, S24, 4  
     402, S25, 4  
 PANT G.C., 244, P5, 3  
 PARAS P., 420, P5, 3  
 PARIS R.D., 334, P3a, 2  
 PARMENTIER N., 356, SO3, 1  
 PARODO A., 302, SO9, 2  
 PATEL B., 221, SO2, 2  
 PATEL S., 221, SO2, 2  
 PATTI F., 358, S21, 3  
 PAULY H., 044, P5, 3  
     315, S22, 3  
 PAWAR S., 221, SO2, 2  
 PELLERIN P., 337, S10, 1  
 PELLICIONI M., 422, P2a, 2  
 PENSKO J., 224, P4a, 3  
 PERRAUD R., 342, S28, 4  
 PERRIER J.C., 356, SO3, 1  
 PERSSON R.B.R., 085, P4c, 3  
     128, P4a, 3  
 PESCAVRE G., 165, P6, 4  
 PETEL M., 167, P6, 4  
 PETER H., 188, S27, 2  
 PETROV V.M., 380, S17, 3  
 PEYRAUD C., 387, P7, 4  
 PFEIFFER K., 188, S27, 2  
 PFISTER H., 315, S22, 3  
 PHALEN R.F., 201, P7, 4  
 PHILIPP G., 315, S22, 3  
 PHILIPPON B., 444, S19, 3  
 PIAGGIO-BONSI R., 164, P6, 4  
 PIESCH E., 338, P6, 4  
 PIETRIK I., 372, S21, 3  
 PIMPALE N.S., 462, P3a, 2  
 PLOTNIKOVA C.D., 238, S14, 4  
 PONCY J.L., 343, S28, 4  
 POPA L., 423, P6, 4  
 PORSTENDORFER J., 207, S22, 3  
 PORTAL G., 163, P6, 4  
     164, P6, 4  
     165, P6, 4  
     346, S24, 4  
 POWELL T.J., 108, S11, 2  
 PREDMERSZKI T., 300, S11, 2  
 PRETRE S., 094, SO8, 2  
 PRICE K.W., 270, P4b, 3  
 PRIGENT R., 162, P1, 1  
     163, P6, 4  
 PRINTZ H., 006, P2b, 2  
 PROKERT K., 214, P4b, 3  
 PRUDHOMME J., 433, S24, 4  
     437, S24, 4  
 PRULOV I., 258, P2a, 2  
 PSZONA S., 432, P2a, 2  
 PUGLIANI L., 195, P5, 3  
 PUITE K.J., 176, P6, 4  
 QUINTILIANI M., 301, SO6, 1  
 RAABE O.G., 201, P7, 4  
 RAGGENBASS A., 424, S21, 3  
 RAGHAVAYYA M., 125, S10, 1  
 RAMZAEV P.V., 489, SO4, 1  
     490, SO1, 1



- RANGHIASCI C., 485, S07, 2  
 RAWAT B.S., 032, P3a, 2  
 RECHT P., 469, S08, 2  
 REICH H., 384, S03, 1  
 REISS J., 241, S12, 2  
 RENOIX A., 386, S18, 3  
     387, P7, 4  
 RENZETTI A., 154, S18, 3  
 REPACHOLI M.H., 130, S07, 2  
 REYX C., 293, S27, 2  
 RICHINGS L.D.G., 038, S29, 4  
     086, S29, 4  
 RICHMOND J.S., 447, P7, 4  
 RICOURT A., 356, S03, 1  
 RIEL G.K., 446, P4a, 3  
 RIEL G., 447, P7, 4  
 RIMONDI O., 418, S07, 2  
 RIOCREUX M., 250, P5, 3  
 RO S.G., 415, P1, 1  
 RODIONOVA I.F., 489, S04, 1  
 ROLLIN Ph., 367, S20, 3  
 ROMBAUX J.P., 525, S27, 2  
 RON E., 096, S17, 3  
 RONIN M.Y., 236, S 14, 4  
 ROSENSTEIN M., 071, S09, 2  
 ROSEN TAL N., 258, P2a, 2  
 ROSNER G., 341, S02, 2  
 ROSSBANDER G.T., 213, S21, 3  
 ROTHSCHILD H.C., 206, S20, 3  
 ROUHANTZADEH N., 527, S20, 2  
 ROUSHDY H.M., 018, S25, 4  
 ROWE R.W., 413, P6, 4  
 RUST J.H., 229, S24, 4  
 RYFLUKU H., 118, P1, 1
- SAINT-JEAN P., 434, P6, 4  
 SAJAROFF P., 162, P1, 1  
 SAKANOUÉ M., 131, S05, 2  
 SALVADORI P., 195, P5, 3  
 SAMUEL T., 148, S27, 2  
 SANDSTROM A., 294, P3b, 2  
 SANKARANARAYANAN N., 182, S07, 2  
 SANTORTI G., 154, S18, 3  
 SAUBERMANN P.F., 006, P2b, 2  
 SAUROV M.M., 408, S01, 1  
 SCHAEFFER R., 431, S02, 2  
 SCHEIBEL H.G., 207, S22, 3  
 SCHLAPAK V.N., 412, P1, 1  
 SCHLENKER R.A., 191, P7, 4  
 SCHLESINGER T., 429, P7, 4  
 SCHMIDT Th., 044, P5, 3  
 SCHMIDTLEIN P., 280, S20, 3  
 SCHNEPP H., 366, S20, 3  
 SCHRAUB A., 207, S22, 3  
 SCHUMACHER H., 404, P5, 3  
 SCHULER H., 299, S05, 2  
 SCHULTZ H., 160, P3b, 2  
     161, P3b, 2  
 SCHUREN H., 246, P1, 1  
 SCHURICHT V., 214, P4b, 3  
     216, P2b, 2  
 SCHUTTMANN U.L., 213, S21, 3  
 SCHUTTMANN W., 218, S25, 4  
 SCHWARZ G., 278, S20, 3  
     280, S20, 3  
     281, S20, 3
- SEDLAK A., 264, S28, 4  
 SEDLET J., 049, P4c, 3  
 SEGUIN H., 379, S03, 1  
 SEIDEL A., 089, S24, 4  
 SELBY J.M., 407, S08, 2  
 SEPHTON J., 413, P6, 4  
 SHARMA R.C., 462, P3a, 2

- SHIROTANI T., 116, P3a, 2  
 SHLEIEN B., 149, P5, 3  
 SHOFFNER B.M., 105, P6, 4  
 SHRADER E.F., 105, P6, 4  
 SHREVE J.D., 091, P1, 1  
 SHUBIK V.M., 489, S04, 1  
 SIMOLA K., 205, P4c, 3  
 SIMONE G., 301, S06, 1  
 SINGH D.R., 182, S07, 2  
 SITZLACK G., 242, S29, 4  
 SMIRENNY L.N., 380, S17, 3  
 SMITH H., 062, P7, 4  
 SNIHS J.O., 228, S17, 3  
 SNYDER W.S., 208, S09, 2  
     313, S09, 2  
 SOBACIC M.V., 381, P1, 1  
 SOBOLEV A.S., 222, S14, 4  
 SOMAN S.D., 122, P6, 4  
 SOMASUNDARAM S., 462, P3a, 2  
 SOULIE R., 355, P4b, 3  
 SOUMILLION D., 525, S27, 2  
 SPRIET H., 339, S18, 3  
 SPURNY F., 165, P6, 4  
 STAJIC J., 231, S25, 4  
 STARCHMAN D.E., 363, P5, 3  
 STEARNER S.P., 229, S24, 4  
 STEGER F., 145, P4c, 3  
 STEINHAUSLER F., 187, S09, 2  
 STEMMELN E., 426, S02, 2  
 STENSTRAND K., 397, S22, 3  
 STEVENSON G.R., 291, S03, 1  
 STEWART C.G., 513, S13, 2  
 STOJANOVIC D., 185, P2c, 2  
     231, S25, 4  
 STPICZYNSKA Z., 224, P4a, 3  
 STRADLING G.N., 062, P7, 4  
 STRAMBI E., 457, S21, 3  
 STRAND S.E., 063, S09, 2  
 STRAZHEVSKAYA N.B., 236, S14, 4  
 STRELKOV R.B., 236, S14, 4  
 STREUBEL G., 214, P4b, 3  
 STRUCHKOV V.A., 236, S14, 4  
 STUART B.O., 374, S28, 4  
 SUBBA RAMU M.C., 106, S26, 2  
 SUBRAHMANIAN G., 183, S21, 3  
 SUBRAHMANYAM P., 182, S07, 2  
 SUKALSKAYA S.Ya., 489, S04, 1  
 SUNDARA RAO I.S., 183, S21, 3  
 SUNTA C.M., 122, P6, 4  
 SURENDRAN T., 462, P3a, 2  
 SURYANARAYANAN C., 124, S18, 3  
 SZALANCZY A., 105, P6, 4  
 SZTANYIK L.B., 303, S25, 4  
 TACHLINSKI W., 298, S05, 2  
 TAKAVAR A., 413, P6, 4  
     414, P6, 4  
 TAMBA M., 301, S06, 1  
 TANIGUCHI H., 206, S20, 3  
 TARASOV S.I., 490, S01, 1  
 TARVAINEN M., 233, P1, 1  
 TATSUTA H., 118, P1, 1  
 TAYLOR G.N., 333, S25, 4  
 TELL R.A., 304, S07, 2  
 TEPLEY N.W., 173, P4a, 3  
 THIEL J.F., 025, S07, 2  
 THOMAS J., 264, S28, 4  
 THOMAS V.W., 120, S02, 2  
 THOMPSON R.C., 084, S28, 4  
 THORNE M.C., 518, S26, 2  
 TILL J.E., 295, S05, 2  
 TOMMASINO L., 129, P6, 4  
 TOOMBS G.L., 334, P3a, 2  
 TORIO P.P., 040, P2b, 2  
 TRAVAILLON R., 320, P1, 1

- TRIPATHI A., 461, P2c, 2  
 TROESCH G., 481, P1, 1  
 TROTSKAIA M.N., 490, SO1, 1  
 TRUKHANOV K.A., 412, P1, 1  
 TSAI C.M., 186, P3b, 2  
 TSUJIMOTO T., 192, P4a, 3  
 TUCKER T.T., 149, P5, 3  
 TURKIN A.D., 408, SO1, 1  
                   409, S20, 3  
 TUROVSKI V.D., 409, S20, 3  
 TYAZHELOVA V.G., 234, S14, 4  
                   237, S24, 4  
 TYLER J.M.R., 142, SO6, 1
- UCHRLIN G.Y., 340, P6, 4  
 URABE I., 192, P4a, 3
- VALLEY J.F., 134, SO9, 2  
                   135, SO3, 1  
 VAN BRUWAENE R., 391, SO5, 2  
 VAN DER LUGT G., 479, S20, 3  
 VAN DER POL P.C., 066, S19, 3  
 VAN TLINEN R., 420, P5, 3  
 VANA N., 370, P5, 3  
                   371, P6, 4  
 VARANO L.A., 279, S12, 2  
 VARGA L., 103, S25, 4  
 VASHI V.D., 124, S18, 2  
 VASUDEV P., 206, S20, 3  
 VELJKOVIC D., 185, P2c, 2  
 VENNART J., 518, S26, 2  
 VEYRAT M., 437, S24, 4  
 VIALARD J.L., 012, S18, 3
- VISNJIC V., 400, S24, 4  
 VIVJA R., 377, P1, 1  
 VOELZ E., 160, P3b, 2  
                   161, P3b, 2  
 VOGT K.J., 278, S20, 3  
 VOHRA K.G., 226, SO4, 1  
 VOIPIO A., 205, P4c, 3  
 VOLF V., 158, S25, 4
- WAGNER G., 280, S20, 3  
 WAGNER S.R., 312, SO3, 1  
 WAITE D.A., 177, S20, 3  
                   407, SO8, 2  
 WALD N., 327, S25, 4  
 WALINDER G., 228, S17, 3  
 WARNER G.G., 313, SO9, 2  
 WASSER S., 210, S19, 3  
 WATSON E.E., 208, SO9, 2  
 WATSON K.A., 327, S25, 4  
 WATT D.E., 087, P3a, 2  
 WEBB G.A.M., 095, SO1, 1  
 WEISS B.H., 184, SO2, 2  
 WENK G.J., 022, S18, 3  
 WERNER A., 096, S17, 3  
 WERNLI Ch., 099, SO8, 2  
 WESSLEN E., 255, S11, 2  
 WHETMATH P.D.J., 058, P3a, 2  
 WHITE D.R., 057, SO9, 2  
                   253, SO9, 2  
 WHITLOCK G.D., 254, P4a, 3  
 WICKE A., 207, S22, 3  
 WIDELL C.O., 034, S10, 1  
 WIJCKER H., 452, SO8, 2  
                   479, S 20, 3  
 WILLIAMSON F.S., 229, S24, 4  
 WILLRODT U., 281, S20, 3  
 WILSON R., 286, P3b, 2  
 WINDBUHL E., 526, P2b, 2

- WINDHAM S.T., 109, S22, 3  
WINKLER R., 341, S02, 2  
WINTER M., 298, S05, 2  
299, S05, 2  
WOLF W., 429, P7, 4  
WRENN M.E., 460, S08, 2  
WRIXON A.D., 055, S22, 3  
WUKASCH M.C., 024, S21, 3  
025, S07, 2  
065, S22, 3  
WUNEKE C.D., 160, P3h, 2  
161, P3b, 2  
WYCKOFF H.O., 514, S15, 2
- YAMASAKI K., 192, P4a, 3  
YAMATO A., 276, P4c, 3  
YANG V.V., 229, S24, 4  
YOOK C.C., 415, P1, 1  
YOSHIKAZU Y., 118, P1, 1  
YOSHIMOTO T., 192, P4a, 3  
YOSHIZAWA Y., 155, S17, 3
- ZAPARDE S.P., 183, S21, 3  
ZAPPE D., 216, P2b, 2  
ZASEDATELEV A.A., 489, S04, 1  
ZETTWOOG P., 386, S18, 3  
ZIVANOVIC A., 231, S25, 4  
ZUK W.M., 030, S08, 2
- YAAR I., 096, S17, 3  
YAGUZHTNSKY L.S., 235, S06, 1

## PAPER INDEX

## INDEX DES COMMUNICATIONS

S . : *séance orale - oral session*  
 P . : *séance par affiche - poster session*  
 N.A. : *non disponible - non available*

N°	SESSION	VOLUME - PAGE	N°	SESSION	VOLUME - PAGE
004	S 29	4 , 1367	060	P 3B	2 , 573
006	P 2B	2 , 373	061	P 3B	2 , 601
010	S 06	1 , 213	062	P 7	4 , 1399
011	S 14	4 , 1307	063	S 09	2 , 493
012	S 18	3 , 765	065	S 22	3 , 1029
016	S 04	1 , 195	066	S 19	3 , 883
017	S 22	3 , 1021	067	S 02	2 , 243
018	S 25	4 , 1207	068	P 3A	2 , 529
022	S 18	3 , 753	070	S 26	2 , 425
024	S 21	3 , 987	071	S 09	2 , 465
025	S 07	2 , N.A.	072	S 11	2 , 511
026	S 08	2 , 443	083	P 5	3 , 1101
029	P 7	4 , 1407	084	S 28	4 , 1333
030	S 08	2 , N.A.	085	P 4C	3 , 845
032	P 3A	2 , 541	086	S 29	4 , 1371
034	S 10	1 , 37	087	P 3A	2 , 657
036	S 21	3 , 981	089	S 24	4 , 1177
037	S 17	3 , 735	091	P 1	1 , 111
038	S 29	4 , 1351	093	P 7	4 , N.A.
040	P 2B	2 , 385	094	S 08	2 , N.A.
041	S 26	2 , 413	095	S 01	1 , 3
044	P 5	3 , 1091	096	S 17	3 , 723
049	P 4C	3 , 849	099	S 08	2 , 447
050	S 04	1 , 173	100	P 3B	2 , 569
055	S 22	3 , 1061	102	S 03	1 , 65
057	S 09	2 , 475	103	S 17	3 , 703
058	P 3A	2 , 537	104	S 19	3 , 891
059	S 22	3 , 1053	105	P 6	4 , 1229

Nº	SESSION	VOLUME - PAGE	Nº	SESSION	VOLUME - PAGE
106	S 26	2 , 417	161	P 3B	2 , 588
107	P 2A	2 , 343	162	P 1	1 , 117
108	S 11	2 , 519	163	P 6	4 , 1233
109	S 22	3 , 1049	164	P 6	4 , 1249
110	S 18	3 , 761	165	P 6	4 , 1237
113	S 22	3 , 1045	166	S 03	1 , 101
114	P 3A	2 , 508	167	P 6	4 , 1288
116	P 3A	2 , 549	168	P 6	4 , 1241
118	P 1	1 , 151	171	P 4A	3 , 801
119	P 1	1 , 131	172	P 2B	2 , 377
120	S 02	2 , 235	173	P 4A	3 , N.A.
122	P 6	4 , 1285	174	P 4A	3 , 805
124	S 18	3 , 771	175	S 27	2 , 571
125	S 10	1 , 63	176	P 6	4 , 1273
128	P 4A	3 , 789	177	S 20	3 , 953
129	P 6	4 , 1281	178	S 10	1 , 48
130	S 07	2 , 337	179	S 20	3 , 929
131	S 05	2 , 647	182	S 07	2 , 333
134	S 09	2 , 467	183	S 21	3 , 969
135	S 03	1 , 97	184	S 02	2 , N.A.
136	S 02	2 , 275	185	P 2C	2 , 399
138	P 4C	3 , 841	186	P 3B	2 , 581
141	S 06	1 , 225	187	S 09	2 , 497
142	S 06	1 , 229	188	S 27	2 , 667
145	P 4C	3 , 853	191	P 7	4 , N.A.
148	S 27	2 , 663	192	P 4A	3 , 785
149	P 5	3 , 1105	193	S 05	2 , 637
150	P 5	3 , 1117	195	P 5	3 , 1083
151	S 20	3 , 927	201	P 7	4 , 1363
153	P 4A	3 , 813	202	P 4C	3 , 861
154	S 18	3 , 757	205	P 4C	3 , 857
155	S 17	3 , 727	206	S 20	3 , N.A.
156	P 3A	2 , 533	207	S 22	3 , 1057
157	S 03	1 , 77	208	S 09	2 , 479
158	S 25	4 , 1219	209	P 5	3 , 1113
159	P 6	4 , 1277	210	S 19	3 , 895
160	P 3B	2 , 585	212	S 29	4 , 1355

Nº	SESSION	VOLUME - PAGE	Nº	SESSION	VOLUME - PAGE
213	S 21	3 , N.A.	255	S 11	2 , 575
214	P 4B	3 , 831	258	P 2A	2 , 351
216	P 2B	2 , 357	260	S 25	4 , 1215
218	S 25	4 , 1187	261	S 09	2 , 480
219	S 09	2 , 507	263	P 5	3 , 1087
220	S 03	1 , 59	264	S 2B	4 , 1341
221	S 02	2 , 253	270	P 4B	3 , 827
222	S 14	4 , 1289	274	P 2C	2 , N.A.
223	P 7	4 , 1387	276	P 4C	3 , 865
224	P 4A	3 , 793	278	S 20	3 , 921
226	S 04	1 , 781	279	S 12	2 , 203
227	S 01	1 , 27	280	S 20	3 , 513
228	S 17	3 , 711	281	S 20	3 , 945
229	S 24	4 , 7143	282	P 3B	2 , 597
230	P 5	3 , 1099	283	S 12	2 , 297
231	S 25	4 , 1223	284	P 2A	2 , 355
232	S 29	4 , 1359	285	S 12	2 , 289
233	P 1	1 , 147	286	P 3B	2 , 577
234	S 14	4 , 1303	287	S 20	3 , 977
235	S 06	1 , 217	288	S 21	3 , 395
236	S 14	4 , 1311	289	S 21	3 , 399
237	S 24	4 , 1167	291	S 03	1 , 93
238	S 14	4 , 1313	292	S 09	2 , N.A.
239	S 14	4 , 1305	293	S 27	2 , 667
241	S 12	2 , 365	294	P 3B	2 , 533
242	S 12	2 , 307	295	S 05	2 , 645
244	P 5	3 , 1103	298	S 05	2 , 613
245	S 19	3 , 879	299	S 05	2 , 627
246	P 1	1 , 143	300	S 11	2 , 567
247	P 7	4 , 1321	301	S 06	1 , 221
248	P 5	3 , 1127	302	S 09	2 , 483
250	P 5	3 , 1129	303	S 25	4 , 1203
251	S 04	1 , 199	304	S 07	2 , 329
252	S 10	1 , 45	305	S 01	1 , 19
253	S 09	2 , 491	306	P1	1 , 139
254	P 4A	3 , 803	307	P 6	4 , 1257

N°	SESSION	VOLUME-	PAGE	N°	SESSION	VOLUME-	PAGE
309	S 06	1	, 209	367	S 20	3	, 933
311	S 21	3	, 991	370	P 5	3	, 1185
312	S 03	1	, 69	371	P 6	4	, 1263
313	S 09	2	, 469	372	S 21	3	, N.A.
315	S 22	3	, 1047	374	S 28	4	, 1337
316	S 27	2	, 659	377	P 1	1	, 135
318	S 26	2	, 421	379	S 03	1	, 81
320	P 1	1	, 167	380	S 17	3	, 737
327	S 25	4	, 1153	381	P 1	1	, 123
330	S 04	1	, 203	382	S 03	1	, 105
332	S 10	1	, 41	383	S 14	4	, N.A.
333	S 25	4	, 1211	384	S 03	1	, 73
334	P 3A	2	, 525	385	P 2A	2	, 359
335	S 17	3	, 715	386	S 18	3	, 749
337	S 10	1	, 33	387	P 7	4	, 1395
338	P 6	4	, 1845	388	S 02	2	, 255
339	S 18	3	, 775	389	S 02	2	, 247
340	P 6	4	, 1261	391	S 05	2	, 625
341	S 02	2	, 257	392	S 02	2	, 263
342	S 28	4	, 1345	393	P 1	1	, 159
343	S 28	4	, 1387	397	S 22	3	, 1033
344	S 28	4	, 1329	398	P 2A	2	, 347
346	S 24	4	, 1153	400	S 24	4	, 1165
350	P 1	1	, 127	401	P 4B	3	, 223
351	S 22	3	, 1017	402	S 25	4	, 1195
352	S 05	2	, 533	403	P 3B	2	, 603
354	P 3B	2	, 607	404	P 5	3	, 1035
355	P 4B	3	, 835	407	S 08	2	, 439
356	S 03	1	, 89	408	S 01	1	, N.A.
357	P 3A	2	, 563	409	S 20	3	, 905
358	S 21	3	, 873	410	S 04	1	, 189
359	S 21	3	, 977	411	S 22	3	, 1037
361	P 7	4	, 1493	412	P 1	1	, 119
363	P 5	3	, 1075	413	P 6	4	, 1265
364	S 21	3	, N.A.	414	P 6	4	, 1269
366	S 20	3	, 341	415	P 1	1	, 155



Nº	SESSION	VOLUME - PAGE	Nº	SESSION	VOLUME - PAGE
416	P 5	3 , 1079	469	S 08	2 , 431
418	S 07	2 , 321	472	S 19	3 , 899
419	S 22	3 , 1009	473	P 4A	3 , N.A.
420	P 5	3 , 1087	476	S 09	2 , 471
421	P 3B	2 , N.A.	479	S 20	3 , 924
422	P 2A	2 , 367	481	P 1	1 , 103
423	P 6	4 , N.A.	483	S 05	2 , 628
424	S 21	3 , 1003	484	S 03	1 , 86
425	S 29	4 , 1375	485	S 07	2 , 325
426	S 02	2 , 267	489	S 04	1 , 185
427	S 18	3 , 741	490	S 01	1 , 23
428	S 01	1 , 16	511	S 09	2 , N.A.
429	P 7	4 , 1417	512	S 12	2 , 221
431	S 02	2 , 271	513	S 13	2 , N.A.
432	P 2A	2 , 363	514	S 15	2 , 693
433	S 24	4 , 1169	515	S 16	3 , 693
434	P 6	4 , 1293	516	S 19	3 , 571
435	S 25	4 , 1199	517	S 23	4 , 1133
437	S 24	4 , 1157	518	S 26	2 , 495
438	S 24	4 , 1173	519	S 30	4 , N.A.
441	S 20	3 , 949	521	S 07	2 , 311
442	P 4A	3 , 757	523	S 07	2 , 315
444	S 19	3 , 887	524	S 07	2 , 319
446	P 4A	3 , 817	525	S 27	2 , 645
447	P 7	4 , 1413	526	P 2B	2 , 389
449	P 5	3 , 1071	527	S 20	3 , 855
451	S 01	1 , 11			
452	S 08	2 , 481			
455	S 22	3 , 1025			
457	S 21	3 , 961			
460	S 08	2 , 435			
461	P 2C	2 , 395			
462	P 3A	2 , 545			
463	S 29	4 , 1363			
466	S 18	3 , 779			
467	S 17	3 , 719			