

IRPA8

**Association internationale
de radioprotection**

**International Radiation
Protection Association**



ACTES DU CONGRÈS / PROCEEDINGS

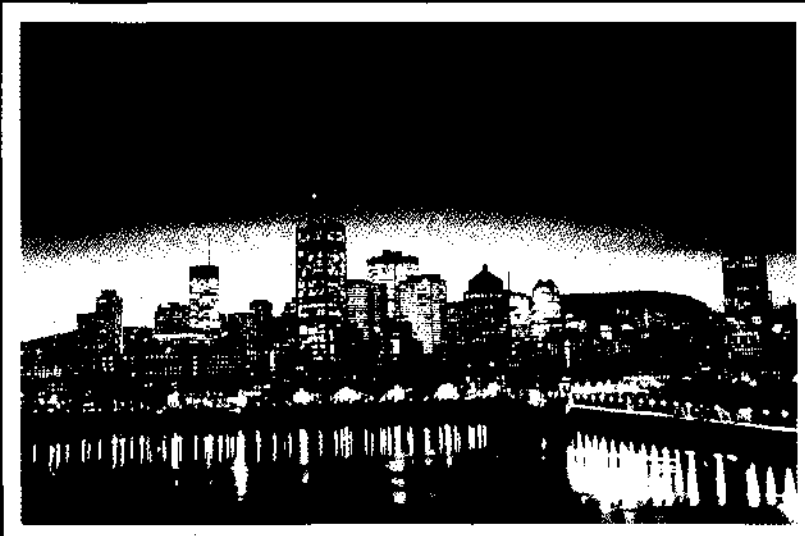

MONTREAL 92-05-17 AU/TO 92-05-22

PALAIS DES CONGRÈS

IRPA8

Huitième Congrès International de
l'Association Internationale de
Radioprotection

Eighth International Congress of the
International Radiation Protection
Association

du 17 au 22 May, 1992

May 17-22, 1992

Montréal, Canada

**Réalisations Mondiales au Niveau
de la Protection de la Santé du
Public et des Travailleurs contre
les Rayonnements**

**Worldwide Achievement in
Public and Occupational
Health Protection
Against Radiation**

Volume I

Organisé par l'Association Canadienne de Radioprotection

Organized by the Canadian Radiation Protection Association



Copyright ©1992, International Radiation Protection Association

Tous droits réservés. Toute représentation ou reproduction intégrale, ou partielle, faite par quelque procédé que ce soit - polycopie, photocopie, microfilm, bande magnétique, disque ou autre, sans le consentement de l'Association Internationale de Radioprotection, est strictement interdite.

All rights reserved. No part of this publication may be reproduced, stored in a retrieval system or transmitted in any form or by any means, electronic, electrostatic, magnetic tape, mechanical photocopying, recording or otherwise, without permission from the International Radiation Protection Association.

**International Radiation Protection Association
2155 rue Guy, Bureau 820
Montréal, Québec
Canada H3H 2R9**

**Printed in Montmagny by l'imprimerie d'édition Marquis Itée
ISBN 1-55048-657-8**

CONTENU / CONTENTS

VOLUME 1

- ♦ Preface
- ♦ Remerciements / Acknowledgements
- ♦ Comités internationaux d'organisation /
International Congress Committees
- ♦ Table des matières / Table of contents
- ♦ Actes du congrès / Proceedings
18 et 19 mai 1992 / May 18 and 19, 1992

VOLUME 2

- ♦ Table des matières / Table of contents
- ♦ Actes du congrès / Proceedings
20-22 mai 1992 / May 20-22, 1992
- ♦ Index des auteurs / Author Index

PREFACE

The International Radiation Protection Association (IRPA) is an autonomous, non-government association. IRPA has over 15,000 members in 31 associate societies which are active in 36 different countries: Argentina, Australia, Austria, Belgium, Brazil, Canada, China, Czechoslovakia, Denmark, Finland, France, Germany, Greece, Hungary, Iceland, India, Luxembourg, Mexico, Netherlands, Norway, Peru, Philippines, Poland, South Africa, Spain, Sweden, Switzerland, United Kingdom, USA, USSR, Yugoslavia.

The primary purpose of IRPA is to provide a system whereby those engaged in radiation protection activities in all countries may communicate more readily with each other and through this process advance radiation protection in many parts of the world. The first international IRPA Congress was convened in Rome, Italy in 1966. Subsequent IRPA congresses took place in

Brighton, UK, 1970
Washington, D.C., USA, 1973
Paris, France, 1977
Jerusalem, Israel, 1980
West Berlin, Germany, 1984
Sydney, Australia, 1988

The Eighth International Congress of the International Radiation Protection Association (IRPA8) will be held in Montreal, Canada from May 17 - 22, 1992. IRPA8 is co-sponsored by the Canadian Radiation Protection Association.

IRPA8 will be preceded by the second International Workshop on Non-Ionizing Radiation in Vancouver, British Columbia from May 10 - 14, 1992. This workshop is a joint project of the Canadian Radiation Protection Association and the International Non-Ionizing Radiation Committee of the International Radiation Protection Association. Proceedings from this workshop will be published separately.

The present two volumes contain the preprints of papers to be presented at IRPA8 in Montreal. More than 500 abstracts were submitted for consideration by the International Congress Program Committee. Most of the abstracts were accepted and allocated to oral or poster sessions. Oral and poster presentations are regarded by the Committee as being of equal importance. Poster papers will be on display throughout the Congress, and will be summarised by rapporteurs in the appropriate oral sessions.

PREFACE

L'Association internationale de Radioprotection (AIRP) est une association autonome, non gouvernementale. L'AIRP compte plus de 15.000 membres dans 31 sociétés affiliées, actives dans 36 pays: Afrique du Sud, Allemagne, Argentine, Australie, Belgique, Brésil, Canada, Chine, Corée, Danemark, Espagne, Etats-Unis d'Amérique, Finlande, France, Grèce, Hongrie, Islande, Italie, Inde, Irlande, Israël, Japon, Luxembourg, Mexique, Norvège, Pays-Bas, Pérou, Philippines, Pologne, Royaume-Uni, Russie, Suède, Suisse, Tchécoslovaquie, Yougoslavie.

L'objectif premier de l'AIRP est de fournir un forum aux personnes travaillant dans le domaine de la radioprotection dans tous les pays, facilitant ainsi la communication entre eux, afin de faire avancer la radioprotection partout dans le monde. Le premier congrès international de l'AIRP a eu lieu à Rome, en Italie, en 1966. Les congrès suivants de l'AIRP se sont tenus à:

Brighton, Royaume-Uni, 1970
Washington, USA, 1973
Paris, France, 1977
Jérusalem, Israël, 1980
Berlin Ouest, Allemagne, 1984
Sydney, Australie, 1988

Le Huitième Congrès International de l'Association Internationale de Radioprotection (IRPA8) se tiendra à Montréal, Canada, du 17 au 22 mai 1992. IRPA8 est projet conjoint de l'Association Canadienne de Radioprotection et de l'AIRP.

IRPA8 sera précédé du second Atelier International sur les Rayonnements Non Ionisants, à Vancouver, Colombie Britannique, du 10 au 14 mai 1992. Cet atelier est un projet conjoint de l'Association Canadienne de Radioprotection et du Comité international des Rayonnements Non Ionisants de l'Association Internationale de Radioprotection. Les compte-rendus de cet atelier seront publiés séparément.

Les deux volumes des compte-rendus IRPA8 contiennent des textes pour pré-publication des communications présentées à Montréal. Plus de 500 résumés de communication ont été soumis au comité du programme du congrès international. La plupart des résumés ont été acceptés et une séance a été déterminée pour chaque communication pour présentation orale ou par affiche.

Authors of both types of papers were invited to submit four pages of camera-ready text for publication in these volumes. Plenary papers were allocated up to eight pages. All papers are reproduced without editorial amendment. The responsibility for the content and format of papers rests with the individual authors.

The papers are arranged by session in chronological order of presentation, as far as possible. This sequence is adopted to enable papers to be located easily and to avoid the need for registrants to carry both volumes throughout the Congress. In addition to the usual tables of Contents, the second volume includes an Author Index.

Abstracts are provided in place of the papers which were not received in time for inclusion in the proper sequence. Some late papers are included in an Addendum in the second volume.

These volumes constitute the record of the Congress, and provide an interesting collection of papers which describe the current worldwide practice of radiation protection. We thank the authors for their indispensable contribution to the Congress.

The members of the International Congress Organising Committee and the International Congress Program Committee have worked hard to ensure a successful Congress. It is our pleasure to thank them for efforts that merit the gratitude of those who attend the Congress, and of subsequent readers of these volumes.

Aux yeux du comité, les deux types de communication, orale ou par affiche, ont une importance égale. Les affiches demeureront en place pour la durée du congrès et seront résumées par un rapporteur lors de la séance à laquelle elles ont été attribuées. Les auteurs des deux types de communication ont été invités à soumettre 4 pages de texte prêt à photographier pour publication dans ces volumes. Les conférenciers invités des séances plénières soumettaient 8 pages de texte. Tous les textes ont été reproduits sans aucune modification, tels que soumis. Les auteurs étaient responsables du contenu et du format de leur texte.

Dans ces deux volumes de compte-rendus, les communications sont groupées par séance, selon l'ordre chronologique de leur présentation, dans la mesure du possible. Le premier volume contient les communications présentées lors des deux premiers jours; ainsi il ne sera pas nécessaire de porter les deux volumes tout au long du congrès. En plus des tables des matières de chaque volume, on trouvera un index des auteurs dans le second volume. A la fin du second volume se trouvent les communications recues tardivement. Les deux volumes de compte-rendus constituent les archives du congrès, et présentent une collection intéressante de travaux décrivant les réalisations mondiales de la radioprotection à l'heure actuelle. Nous remercions les auteurs pour leur contribution indispensable au succès du congrès.

Les membres du comité organisateur et du comité du programme du congrès international ont fourni beaucoup d'efforts pour assurer le succès du congrès. C'est avec plaisir que nous les remercions de leurs efforts; ils ont mérité la gratitude de tous les participants au congrès, et des éventuels lecteurs de ces volumes.

Jean-Pierre Gauvin
G.A.M. Webb
Roch D. DesRochers

IRPA8 INTERNATIONAL CONGRESS ORGANISING COMMITTEE

COMITÉ INTERNATIONAL D'ORGANISATION IRPA8

Jean-Pierre Gauvin, président / Chairman
Michel Rhéaume, trésorier / treasurer
Roch D. Desrochers, secrétaire scientifique / scientific secretary
Claude Dufour, coordonnateur exposants / Exhibition coordinator
Robert Bradley
Pierre Caron
David Grogan
John R. A. Lakey, (ex-officio)
Richard Osborne
John Paciga, Publications

INTERNATIONAL CONGRESS PROGRAMME COMMITTEE

COMITÉ INTERNATIONAL DU PROGRAMME

G.A.M. Webb, président / Chairman Royaume Uni / United Kingdom	W. A. Mills États-Unis / United States
John Lakey (ex-officio) président de l'IRPA / IRPA President Royaume Uni / United Kingdom	Michael Repacholi Australie / Australia
Roch D. DesRochers secrétaire scientifique / Scientific Secretary, Canada	Laurent Stricker France
Jean-Pierre Gauvin (ex-officio) vice président de l'IRPA congrès IRPA Vice-President for Congress Affairs Canada	Guy Uzzan France
Felix F. Luykx Luxembourg	Y. Yoshizawa Japon / Japan

REMERCIEMENTS

Les travaux d'organisation du huitième congrès International de radioprotection ont débuté en avril 1988, immédiatement après la décision de l'assemblée générale de l'Association internationale de radioprotection d'accepter l'invitation de l'Association canadienne de radioprotection.

Outre les quelques 1000 auteurs et co-auteurs qui constituent l'essence même de ce congrès, plus d'une centaine de personnes, membres de comité officiels pour quelques uns et non-membres pour la majorité, ont travaillé de pieds fermes afin que tout soit prêt à temps et que les participants bénéficient du cadre idéal pour l'échange de connaissances et l'avancement de la radioprotection.

Durant les quatre années qu'ont duré les préparatifs, nous avons bénéficié d'un solide appui financier sans lequel, l'organisation de ce congrès n'aurait pas été possible. Nous désirons remercier particulièrement les organismes suivants pour leur importante contribution:

Hydro-Québec,

Commission de la santé et de la sécurité du travail du Québec,

Gouvernement du Québec,

Gouvernement du Canada,

Hydro-Ontario,

New Brunswick Electric Power Commission,

Commission des communautés économiques européennes,

Énergie atomique du Canada Ltée.

Jean-Pierre Gauvin
Président IRPA8

ACKNOWLEDGEMENTS

Duties required for the organisation of the Eight International Congress of Radiation Protection began in April 1988, immediately following the decision of the General Assembly of IRPA to accept the Canadian Radiation Protection's invitation to host IRPA8.

In addition to the 1000 authors and co-authors, who constitute the essence of this congress, over one hundred individuals, members of official committees, and non-members for the majority worked laboriously to prepare everything in time and to ensure that the participants benefit from the best frame for exchanging knowledge and for the advancement of Radiation Protection.

During the four years of the preparatory works, we benefitted from a strong financial support, without which it would have been impossible to hold the Congress. We wish to thank particularly the following organisations for their important contribution:

Hydro-Québec,

Commission de la santé et de la sécurité du travail du Québec,

Government of Québec,

Government of Canada,

Toronto-Hydro,

New Brunswick Electric Power Commission,

Commission of European Communities

Atomic Energy of Canada Ltd

Jean-Pierre Gauvin
Chairman, IRPA8

TABLE DES MATIERES -- TABLE OF CONTENTS

SESSION 1	OPENING CEREMONIES AND SIEVERT LECTURE CÉRÉMONIE D'OUVERTURE ET CONFÉRENCE SIEVERT	
	ETHICAL ISSUES IN RADIATION PROTECTION GIOVANNI SILINI. (ITALY)	1
SESSION 2A	COMPARISON OF RISKS - INFORMATION AND EDUCATION OF THE PUBLIC COMPARAISON DES RISQUES - INFORMATION ET SENSIBILISATION DU PUBLIC	
	COMPARABILITY OF RISKS CHRIS HUYSKENS. (THE NETHERLANDS)	18
	BILAN D'UNE ETUDE REGIONALE SUR CERTAINES NUISANCES SUBIES PAR LE PUBLIC JOCELYNE AIGUEPERSE, ANGUENOT F., HARDY S. (FRANCE)	22
	INFORMATION DES MEDECINS A PROPOS DES RISQUES NUCLEAIRES: EXPERIENCES DES INDUSTRIES ELECTRONUCLEAIRES FRANCAISE, BELGE, ALLEMANDE MICHEL BERTIN (F), J.M. CORDIER (B), D. HUBERT (F), J. LALLEMAND (F), H. PFOB (G), G. HEINEMANN (G). (FRANCE, BELGIUM, GERMANY)	26
	THE COMPARATIVE ESTIMATION OF THE RADIATION AND CHEMICAL CARCINOGENIC RISK INDUCED BY THE ATMOSPHERE CONTAMINATION DUE TO THE RELEASES FROM COAL-FIRED POWER PLANTS V.A. KNIZHNIKOV, V.A. KOMLEVA, N.K. SHANDALA. (U.S.S.R.)	30
	METHODS AND PRINCIPLES FOR MAKING PRIORITIES IN RADIATION PROTECTION J.O. SNIHS. (SWEDEN)	34
	NEW SETTING-UP OF THE CRITERION OF ACCEPTABILITY OF RISK IN THE RADIOPROTECTION SECTOR LIDIA FAILLA. (ITALY)	38
	L'INFORMATION DE LA POPULATION DE L'ISERE EN MATIERE DE RISQUES TECHNOLOGIQUES MAJEURS ET PLUS PARTICULIEREMENT DE RISQUE NUCLEAIRE H. DE CHOUDENS. (FRANCE)	42
	TCHERNOBYL: ANALYSE DE L'INFORMATION DONNEE PAR LES MEDIAS DOMINIQUE HUBERT, J.P. CHAUSSADE. (FRANCE)	53
	PERCEPTION DES RISQUES ET DE LA SECURITE CHEZ LES TRAVAILLEURS DU NUCLEAIRE MARIE-HELENE BARNY, J. BRENOT, A. MOREAU. (FRANCE)	57

SESSION 2C	EXPOSURE TO THE PUBLIC FROM RADIOACTIVE MATERIALS IN THE ENVIRONMENT EXPOSITION DU PUBLIC PAR LES SUBSTANCES RADIOACTIVES DANS L'ENVIRONNEMENT	
	EVALUATION DES CONSEQUENCES RADIOLOGIQUES DES REJETS GAZEUX EN SITUATION ACCIDENTELLE Y.H. BOUGET. (FRANCE)	61
	PUBLIC EXPOSURE RESULTING FROM DISCHARGES TO ATMOSPHERE FROM THE NUCLEAR FUEL REPROCESSING PLANT AT SELLAFIELD IN THE UNITED KINGDOM STEPHEN RICHARD JONES, J. FULKER. (UNITED KINGDOM)	65
	THE HISTORY OF CRITICAL GROUP DOSES FROM THE CONSUMPTION OF FRESHWATER FISH AT TRAWSFYNYDD, NORTH WALES R.P. LEONARD. (UNITED KINGDOM)	70
	COMPARATIVE STUDY OF THE BEHAVIOUR OF RADIOCAESIUM AND RADIOSTRONTIUM FROM DIFFERENT SOURCE TERMS IN PASTURES. CHRISTIAN M. VANDECASTEELE, M. VAN HEES, C. HURTGEN, R. KIRCHMANN. (BELGIQUE)	74
	A COMPUTER MODEL FOR THE CALCULATION OF DERIVED EMISSION RELEASE LIMITS FOR THE NORMAL OPERATION OF NUCLEAR FACILITIES BERTRAND THERIAULT. (CANADA)	78
	PRESENTATION AND INTERPRETATION OF FIELD EXPERIMENTS OF GASEOUS UF6 RELEASES IN THE ATMOSPHERE B. CRABOL, D. BOULAUD, G. DEVILLE-CAVELIN, C. GEISSE, L. IACONA. (FRANCE)	82
	ETUDE EXPERIMENTALE DE LA REPARTITION ENTRE SOL ET PLANTES DES DEPOTS D'AEROSOLS ATMOSPHERIQUES MICRONIQUES H. CAMUS, D. GAUTHIER, C. CAPUT, C. SOYER, R. ESCARIOT. (FRANCE)	86
SESSION 2D	CALIBRATION AND MEASUREMENT TECHNIQUES ÉTALONNAGE ET TECHNIQUES DE MESURE	
	HIGH TEMPERATURE PEAK CHARACTERISTICS OF THE READER-ANNEALED TLD-600 AND ITS APPLICATION TO PERSONNEL PROTECTION DOSIMETRY IN MIXED NEUTRON-PHOTON FIELD JAMES LIU, C.S. SIMS. (U.S.A.)	90
	RADIATION MONITORING SYSTEM APPLICABLE TO A NUCLEAR FUSION EXPERIMENTAL SITE H. OBAYASHI, M. MIYAJIMA, J. KODAIRA, Y. SAKUMA, T. YAMAMOTO. (JAPAN)	98
	HIGH LEVEL DOSIMETRY AT THE STANFORD LINEAR ACCELERATOR CENTER ELIZABETH IPE, J.C. LIU. (U.S.A.)	102

SILENE: SOURCE DE RAYONNEMENTS DE REFERENCE R. MEDIONI, F. BARBRY. (FRANCE)	108
SOME DOSIMETRIC CHARACTERISTICS OF THE RESIDUAL DOSE AND THE P TTL FOR LiF:Ti BARAK BEN-SHACHAR, U. GERMAN, E. NAIM. (ISRAEL)	112
MEASUREMENT OF LOW PHOTON EXPOSURES USING A FULL AUTOMATIC PHOSPHATE GLASS DOSIMETRY SYSTEM WITH UV LASER EXCITATION E. PIESCH, B. BURGKARDT, M. VILGIS. (GERMANY)	116
PROTECTION CONTRE LE BREMSSTRAHLUNG SUR MOLECULES RESIDUELLES DE LA CHAMBRE A VIDE D'UN ANNEAU DE STOCKAGE D'ELECTRONS OU DE POSITONS DANS UN CENTRE PRODUCTEUR DE RAYONNEMENT SYNCHROTRON JEAN-CLAUDE FRANCK. (FRANCE)	120
THE URINALYSIS INTERCOMPARISONS ADMINISTERED BY CANADA'S NATIONAL REFERENCE CENTRE FOR RADIOBIOASSAY - HAVE THEY MADE A DIFFERENCE ? MARIA LIMSON ZAMORA, M. GODDARD, R. FALCOMER, W. HUNT, G. MOODIE. (CANADA)	124
EVALUATION OF SURFACE CONTAMINATION BASED ON CERTIFIABLY TRACEABLE INTERNATIONALLY ACCREDITABLE MEASUREMENTS G.D. WHITLOCK. (ENGLAND)	128
APPLICATION OF THIN MEMBRANE SOURCES FOR PREPARATION OF BETA-RAY DOSE CALIBRATION SOURCES IN SKIN CONTAMINATION MEASUREMENT MAKOTO YOSHIDA, HIROYUKI MURAKAMI, KAZUYOSHI BINGO. (JAPAN)	132
INSTALLATION D'ETALONNAGE DES INSTRUMENTS DE MESURE DE LA CONTAMINATION ATMOSPHERIQUE PAR AEROSOLS RADIOACTIFS NATURELS OU ARTIFICIELS JEAN CHARUAU, LILIANE GRIVAUD, MICHEL LE BRETON. (FRANCE)	136
DUAL TYPE NEUTRON MONITOR FOR BURST X-N MIXED FIELD H. OBAYASHI, J. KODAIRA, Y. SAKUMA, Y. MORIUCHI, SATO, T. YAMAMOTO. (JAPAN)	140
CALIBRATION OF PARALLEL PLATE IONIZATION CHAMBERS IN DIFFERENT KINDS OF RADIATION LINDA CALDAS, MARIA ALBUQUERQUE. (BRAZIL)	144
THE NEW PERSONNEL NEUTRON DOSIMETRY SYSTEM AT THE PAUL SCHERRER INSTITUTE CHRISTIAN WERNLI, K. LANGEN. (SWITZERLAND)	148
DEVELOPMENT OF REAL TIME PERSONAL NEUTRON DOSIMETER WITH TWO SILICON DETECTORS TAKASHI NAKAMURA, N. TSUJIMURA, T. YAMANO. (JAPAN)	152
DETERMINATION OF AMBIENT DOSE EQUIVALENT IN MIXED RADIATION FIELDS BY MEANS OF RECOMBINATION CHAMBER N. GOLNIK, M. ZIELCZYNSKI. (POLAND)	156

FREQUENCY SWEEP ESR SPECTROMETER FOR DOSIMETRY AND DATING	160
HIDEMOTO HARA, H. MORISHIMA, H. KAWAI, Y. NISHIWAKI. (JAPAN)	
SESSION 3A	PUBLIC INFORMATION -I: LITIGATION
	INFORMATION DU PUBLIC -I: LITIGE
LA GESTION DES DECHETS NUCLEAIRES A HAUTE ACTIVITE	164
CHRISTIAN BATAILLE. (FRANCE)	
INFORMATION FOR THE PUBLIC ON NUCLEAR SAFETY IN THE EUROPEAN COMMUNITY: REGULATIONS AND PRACTICES	169
H. ERISKAT, D. TEUNEN. (LUXEMBOURG)	
L'INTEGRATION DES VALEURS SOCIALES ET ETHIQUES DANS LA GESTION DU RISQUE RADIOLOGIQUE	173
JACQUES LOCHARD. (FRANCE)	
MERLINS VS BNFL: A CLAIM FOR DAMAGE TO PROPERTY BY RADIOACTIVITY	174
STEPHEN RICHARD JONES, J.A. COOTE. (UNITED KINGDOM)	
AT-A-GLANCE BROADSHEETS, AN APPROACH TO PUBLIC INFORMATION	178
M.J. GAINES. (UNITED KINGDOM)	
CRITERIA FOR THE COMPENSATION OF RADIATION INDUCED HEALTH DISORDERS IN CZECHOSLOVAKIA	182
V. KLENER, J. SEVC, V. PLACEK. (CZECHOSLOVAKIA)	
PERCEPTION DU NUCLEAIRE ET COMMUNICATION	186
ALAIN MOREAU. (FRANCE)	
SESSION 3B	EXPERIENCE IN THE PRACTICE OF MEDICINE -I
	RADIOPROTECTION DANS LA PRATIQUE DE LA MÉDECINE -I
MORE HANDBOOKS OF TISSUE DOSES IN DIAGNOSTIC RADIOLOGY	190
MARVIN ROSENSTEIN, O.H. SULEIMAN, R.L. BURKHART, G. WILLIAMS. (U.S.A.)	
RADIOLOGICAL IMPACT OF DIAGNOSTIC NUCLEAR MEDICINE TECHNOLOGY ON THE QUEBEC POPULATION (PATIENTS AND WORKERS) IN 1989	194
LOUIS RENAUD, J. BLANCHETTE. (CANADA)	
WORLD-WIDE VARIATIONS IN EXPOSURES OF PATIENTS TO IONISING RADIATION	198
JACK VALENTIN. (SWEDEN)	
AN ANALYSIS OF THE SPATIAL DOSE DISTRIBUTION AROUND THE PATIENT WITH THERAPEUTIC DOSE OF I-131	202
T. ORITO, S. KOGA, A. TAKEUCHI, M. ISHIZAKA, G. TAKESHITA, S. SUZUKI, H. TOYAMA. (JAPAN)	

ABSORBED DOSE TO TECHNICIANS WORKING AT ACCELERATORS FOR RADIATION THERAPY ANJA ALMEN, L. AHLGREN, S. MATTSSON. (SWEDEN)	206
NEUTRON LEAKAGE FROM THE ENTRANCE MAZE OF MEDICAL ELECTRON ACCELERATORS HANS-PETER WEISE. (GERMANY)	210
EXOTIC FILTER MATERIALS FOR DIAGNOSTIC X-RAY EQUIPMENT-ARE THEY SUPERIOR TO COMMONLY AVAILABLE MATERIALS? PAVEL DVORAK, C. LAVOIE. (CANADA)	211
TEST OF MAMMOGRAPHIC EQUIPMENT BY AN OBJECTIVE ASSESSMENT OF IMAGE QUALITY AND DOSE JEAN-FRANCOIS VALLEY, L. DESPONDS, C. DEPEURSINGE, M. GRECESCU, C. HESSLER. (SWITZERLAND)	215
IMPLEMENTATION OF THE QUALITY ASSURANCE PROGRAMME OF THE X RAY RADIATION IN SERBIA - YUGOSLAVIA MIROSLAV TOMASEVIC, DUSKO KOSUTIC, OLIVERA MARINKOVIC. (YUGOSLAVIA)	219
RADIOACTIVE CONTAMINATION DUE TO NUCLEAR MEDICINE EXAMINATIONS IN LIQUID AND GASEOUS MATRICES GIOVANNI TESTONI, T. BERNARDI, D. BERTI, O. TUBERTINI, R. ZANNOLI. (ITALY)	223
RADIOTHERAPIE METABOLIQUE PAR I-131: RISQUES DE CONTAMINATION ET D'IRRADIATION DU PERSONNEL SOIGNANT SERGE COEQUYT, S. PETIT, P. FIALDES, P. LOBRY, R. VERGNES. (FRANCE)	227
IONIZING RADIATION SOURCES USED IN MEDICAL APPLICATIONS IN BRAZIL S.M.V. OLIVEIRA, A.M.C. ARAUJO, G. DREXLER. (BRAZIL)	228
SESSION 3C RADIATION ACCIDENTS -I: CHERNOBYL ACCIDENTS RADIOLOGIQUES -I: TCHERNOBYL	
THE INTERNATIONAL CHERNOBYL PROJECT ABEL GONZALEZ. (AUSTRIA)	232
GENERAL CONCLUSIONS FROM SIX YEARS OF CHERNOBYL-RELATED RESEARCH IN SWEDEN ULF BAVERSTAM, LEIF MOBERG. (SWEDEN)	237
EVALUATION OF COUNTERMEASURES TO BE TAKEN TO ASSURE SAFE LIVING CONDITIONS TO THE POPULATION AFFECTED BY THE CHERNOBYL ACCIDENT IN THE USSR JACQUES LOCHARD, T. SCHNEIDER. (FRANCE)	241
MODELING OF THE TRANSFER OF IODINE AND CESIUM VIA THE GRASS-COW-MILK PATHWAY AFTER THE CHERNOBYL ACCIDENT GERALD KIRCHNER. (GERMANY)	245
CHERNOBYL: A CONTRIBUTION TO OUR LEARNING PROCESS OSVALDO ILARI, C. VIKTORSSON. (FRANCE)	249

RESULTS OF THE IAEA WHOLE BODY COUNTING PROGRAMME IN THE SOVIET UNION	253
RICHARD GRIFFITH, R. OUVRARD, R. HARTMANN, R. HOCHMANN, F. STEGER. (AUSTRIA)	
SUR LES RETOMBEES MONDIALES DE L'ACCIDENT DE TCHERNOBYL	257
ANDRE DOURY. (FRANCE)	
INHALATION OF NONVOLATILE RADIONUCLIDES AFTER THE CHERNOBYL ACCIDENT - A RETROSPECTIVE APPROACH	261
GERHARD LINDNER, C. WIHELM, S. KAMINSKI, B. SCHELL, M. WUNDERER, U. WAHL. (GERMANY)	
U.S. DEPARTMENT OF ENERGY CHERNOBYL DATABASE	265
R.A. KENNEDY, J.A. MAHAFFEY, S.K. SMITH, F. CARR. (U.S.A.)	
LA BASE DE DONNEES EUROPEENNES EUROGRID: PROBLEMES METHODOLOGIQUES ET DEVELOPPEMENTS RECENTS	269
SYLVIANE BONNEFOUS, ALAIN DESPRES. (FRANCE)	
MONITORING MAN-MADE RADIATION USING A 256 CHANNEL PORTABLE GAMMA-RAY SPECTROMETER	273
R.L. GRASTY, J. MULTALA, H. LEMMELA. (CANADA)	
RADIATION EXPOSURE DUE TO INCORPORATION OF RADIONUCLIDES IN TWO SELECTED PLACES OF THE RSFSR FIVE YEARS AFTER THE CHERNOBYL ACCIDENT	277
P. HILL, R. HILLE. (GERMANY)	
SESSION 3D	INTERPRETATION AND MEASUREMENT
	INTERPRÉTATION ET MESURES
CALIBRATION OF PERSONAL DOSEMETERS IN TERMS OF THE ICRU OPERATIONAL QUANTITIES	281
JOSEPH MCDONALD, NOLAN HERTEL. (U.S.A)	
EVALUATION OF METHODS OF CALCULATING THE INTERNAL DOSE FROM RADIONUCLIDES DEPOSITED IN THE HUMAN BODY	285
KARL F. MORGAN. (U.S.A)	
PARAMETRES RESPIRATOIRES POUR LA PROTECTION RADIOLOGIQUE	289
M. ROY, M.H. BECQUEMIN, A. BOUCHIKHI, J.F. BERTHOLON. (FRANCE)	
PERSONNEL NEUTRON DOSIMETRY IN BRAZIL: 7 YEARS EXPERIENCE	293
CLAUDIA LUCIA DE PINHO MAURICIO, E.S. FONSECA. (BRAZIL)	
MODELS FOR THE ASSESSMENT OF INTERNAL DOSE AND IMPLICATIONS FOR THEIR PRACTICAL APPLICATION	297
J.ANTHONY GIBSON, R.K. BULL, R.C. CARPENTER. (UNITED KINGDOM)	

ABSOLUTE CALIBRATION OF IN VIVO MEASUREMENT SYSTEMS USING MAGNETIC RESONANCE IMAGING AND MONTE CARLO COMPUTATIONS	301
M.W. MALLET, D.P. HICKMAN, D.A. KRUCHTEN. (U.S.A.)	
RECENT DEVELOPMENTS IN IN-SITU γ SPECTROMETRY	305
PETER JACOB, R. MECKBACH. (GERMANY)	
BRAZIL AND ARGENTINA WHOLE BODY COUNTERS INTERCALIBRATION FOR IN-VIVO MEASUREMENTS OF AM-241 IN BONE	309
C.A.N. OLIVEIRA, MARIA CRISTINA LOURENCO, B.M. DANTAS, M. RIGHETTI, C. ROJAS. (BRAZIL)	
TOWARDS A RELIABLE DOSIMETRY	313
A. BADANO, C. CURBELO. (URUGUAY)	
ELIMINATION OF THE RESIDUAL SIGNAL IN LIF:Cu, Mg, P	317
A. HOROWITZ. (CANADA)	
THE ACTIVITIES OF THE CANADIAN NATIONAL REFERENCE CENTRE FOR IN-VIVO MONITORING	321
GARY KRAMER. (CANADA)	
RADIOACTIVE LEVELS AND DOSES OF H-3 AND C-14 IN WHITE SPIRITS	325
GUOLUN DENG. (CHINA)	
DOSIMETRY FOLLOWING INTERNAL CONTAMINATION: COMPARISON OF SOME BIOASSAY MODELS	326
ALBERT KEVERLING BUISMAN, A. BADREDDINE. (THE NETHERLANDS)	
WHOLE BODY MONITORING OF A LARGE POPULATION SAMPLE	330
M.P. HAYBALL, K. LYTTLE, P.P. DENDY, K.E. GOLDSTONE. (UNITED KINGDOM)	
BIOLOGICALLY-EQUIVALENT DOSIMETRY FROM NITROGEN-14 NUCLEAR QUADRUPOLE RESONANCE	334
DAVID HINTENLANG, LOUIS ISELIN, K. JAMIL. (U.S.A.)	
IS TRACK-ETCH DOSIMETRY READY FOR NEUTRON PERSONAL DOSIMETRY AT HIGH ENERGY ACCELERATORS	338
N. ANTHONY GREENHOUSE. (U.S.A.)	
SESSION 4A PUBLIC INFORMATION - II: PANEL DISCUSSION INFORMATION DU PUBLIC - II: TABLE RONDE	
INFORMING AND EDUCATING THE PUBLIC ON RADIATION RISKS	339
FELIX LUYKX. (LUXEMBOURG)	
MEDIA AND POLITICAL IMPLICATIONS ON RADIATION POLICY IN THE UNITED STATES	343
LYNNE FAIROBENT. (U.S.A)	

MEDICAL X-RAY EXPOSURES IN THE UK G.A.M. WEBB, B.F. WALL. (UNITED KINGDOM)	344
EXPOSITIONS AUX PATIENTS POUR QUELQUES EXAMENS RADIOGRAPHIQUES AU QUEBEC RAYMOND CARRIER, P CHARLAND. (CANADA)	348
ESTIMATION OF EMBRYONIC DOSES IN RADIOLOGICAL EXAMINATION ON UPPER GI-TRACT IN JAPAN KATUMASA OHTA, MICHIAKI KAI, K. KUSAMA. (JAPAN)	352
POTENTIAL EXPOSURES IN RADIATION MEDICINE CESAR ARIAS. (ARGENTINA)	356
DIRECT MAGNIFICATION RADIOGRAPHY AND PATIENT EXPOSURE J. SCHUTZ, H.L. KRONHOLZ, G. REUTHER. (GERMANY)	360
DOSES AND DETRIMENT TO PATIENTS FROM VASCULAR AND INTERVENTIONAL RADIOLOGY F. DIAZ-ROMERO, JOSE HERNANDEZ-ARMAS. (SPAIN)	363
A COMPARISON OF THE EFFECTIVE DOSE EQUIVALENT, H_e , WITH THE WEIGHTED DOSE, W_d , FOR THE SIX-YEAR-OLD PEDIATRIC PATIENT EXPOSED TO CT EXAMINATIONS JOSEPH BLECHINGER, JOHN PRINCE. (U.S.A)	367
DOSIMETRIC EVALUATION PROGRAM FOR DENTAL RADIOLOGY PRACTICES B. GREGORI, J. MILAT, J. FERNANDEZ, S. MICINQUEVICH, J. ANDRIEU. (ARGENTINA)	368
ASSESSMENT OF PATIENT SKIN DOSES IN DIAGNOSTIC RADIOLOGY J.P. WADE, K.E. GOLDSTONE, P.P. DENDY. (UNITED KINGDOM)	372
THE FREQUENCIES AND DOSES OF MEDICAL EXPOSURE IN CHINA ZHANG LIANG AN, ZHANG JINGYUAN, JIA DELIN. (CHINA)	376
ESTIMATION OF ORGAN BIODISTRIBUTION OF ACTIVITIES IN HUMAN FROM EXTERNAL MEASUREMENT WITH TLD T. NAKAMURA, M. MATSUMOTO, H. WATABE, M. ITOH, J. HATAZAWA. (JAPAN)	380
DOSE TO SOME SELECTED ORGANS FROM INTAKE OF RADIONUCLIDES IN INDIAN POPULATION S C JAIN, M. M. GUPTA, A. NAGARATNAM, A. R. REDDY. (INDIA)	384
THE EFFECT OF CHANGE IN TISSUE WEIGHTING FACTORS ON EFFECTIVE DOSE COMPUTATION DUE TO CERTAIN NEW RADIOPHARMACEUTICALS IN INDIAN PATIENTS M.M. GUPTA, S.C. JAIN, A. NAGARATNAM. (INDIA)	388

EFFECT OF NEW ICRP RECOMMENDATIONS ON THE EFFECTIVE DOSE OF SOME NEW RADIOPHARMACEUTICALS	392
M.M. GUPTA, A. NAGARATNAM. (INDIA)	
DISCHARGE LEVEL OF PATIENTS RECEIVED THERAPEUTIC AMOUNT OF RADIOACTIVE IODINE-131	396
S. KOGA, K. KOSHIDA, T. ORITO, A. TAKEUCHI, S. SUZUKI. (JAPAN)	
SESSION 4C RADIATION ACCIDENTS -II: OTHER ACCIDENTS ACCIDENTS RADIOLOGIQUES -II: AUTRES ACCIDENTS	
ROLE OPERATIONNEL DE L'EXPERTISE POUR LA FILIERE AGRO-ALIMENTAIRE EN CAS DE CONTAMINATION RADIOACTIVE ACCIDENTELLE DE L'ENVIRONNEMENT	400
D. MANESSE, R. COULON, C. MADELMONT, N. MELIK, S. MONNOT, A. PERROUX. (FRANCE)	
EFFORTS ENTREPRIS PAR ELECTRICITE DE FRANCE POUR REDUIRE LES REJETS LIQUIDES HORS TRITIUM DES CENTRALES REP	404
P. HARTMANN. (FRANCE)	
DISPERSION OF RADIONUCLIDES AND RADIATION EXPOSURE AFTER LEACHING BY GROUNDWATER OF A SOLIDIFIED CORE-CONCRETE MELT	408
ANTON BAYER, W. TROMM, AL-OMARI. (GERMANY)	
EVALUATION PROBABILISTE DU RISQUE ASSOCIE AU TRANSPORT AERIEN DU PLUTONIUM	412
PHILIPPE HUBERT, J. LOMBART, P. PAGES, F. RANCILLAC. (FRANCE)	
CONTAMINATION MEASUREMENTS ON PERSONS AFTER A NUCLEAR ACCIDENT	416
RUPPRECHT MAUSHART. (GERMANY)	
THE USE OF AN INCOMPLETE INFORMATION DATA BASE FOR THE ASSESSMENTS DURING THE EARLY PHASE OF AN ACCIDENTAL RELEASE OF RADIOACTIVE MATERIAL	420
A. SOHIER, P. GOVAERTS. (BELGIUM)	
DEVELOPPEMENT DES VEHICULES PLAN D'URGENCE INTERNE	424
RAYMOND DOLLO, S. RENIER, Y. TESTINI, M. SONTAG. (FRANCE)	
MOBILE MONITORING UNIT FOR ASSESSING ENVIRONMENTAL RADIOACTIVE CONTAMINATION	428
A. ANDRASI, I. FEHER, I. NEMETH, J. URBAN, P. ZOMBORI. (HUNGARY)	
ETUDE EXPERIMENTALE DU LAVAGE PAR LA PLUIE DES IODES GAZEUX SUSCEPTIBLES D'ETRE EMIS EN CONDITIONS ACCIDENTELLES	432
C. CAPUT, H. CAMUS, D. GAUTHIER, Y. BELOT. (FRANCE)	
GREEN BELT TO REDUCE CONSEQUENCES OF REACTOR ACCIDENTS	436
V.K. GUPTA, RAMESH K. KAPOOR. (INDIA)	

THE RADIATION RISKS OF THE ACCIDENT SPECTRUM OF THE GREEK RESEARCH REACTOR JOHN KOLLAS. (GREECE)	439
HUMAN MILK RADIOACTIVE CONTAMINATION S. RISICA, G. CAMPOS VENUTI, A. DI DOMENICO, G. GRISANTI, L. RAGAZZINI, A. ROGANI, F. TRANCREDI. (ITALY)	443
THE IMPLICATION OF ICRP PUBLICATION 60 FOR NUCLEAR POWER PLANTS R. HOCK. (GERMANY)	447
EVALUATION DE LA FAISABILITE DES MESURES DE PROTECTION ASSOCIEES A UN ACCIDENT DE TRANSPORT AERIEN DE PLUTONIUM F. RANCILLAC, P. PAGES, J. LOMBARD, P. HUBERT. (FRANCE)	451
SESSION 4D INSTRUMENTATION AND MEASUREMENT TECHNIQUES -I INSTRUMENTATION ET TECHNIQUES DE MESURE -I	
FREE RADICAL MEASUREMENT IN BIO-ORGANIC SUBSTANCES USING AN ELECTRON SPIN RESONANCE TECHNIQUE CLIVE GREENSTOCK, A. TRIVEDI. (CANADA)	455
LES COMPTEURS PROPORTIONNELS A MILIEU EQUIVALENT AU TISSU, EN RADIOPROTECTION DANIEL BLANC, PIERRE SEGUR, JEAN BARTHE, JEAN-MARC BORDY. (FRANCE)	459
DESCRIPTION DE L'INSTRUMENT NAUSICAA CONCU POUR EFFECTUER DES MESURES INSTANTANEEES DE D, H ET DU SPECTRE DE T.L.E EN CHAMPS COMPLEXES P. BOUISSET, V.D. NGUYEN, G. KERLAU, L. LEBARON, N. PARMENTIER, M. SIEGRIST, L. BRAAK, B. ALMARCHA, E. DUVIVIER, B. WEICHLEIN, B. MASSON. (FRANCE)	463
MEASUREMENT OF HTO PERMEABILITY OF SOME MATERIALS FOR PROTECTIVE APPLIANCES HIDEAKI YAMAMOTO, MASASHI TOMOOKA, SHOHEI KATO, MIKIO MURATA. (JAPAN)	467
APPORT DE L'INFORMATIQUE DANS LES CONTROLES EN CONTINU DE LA RADIOACTIVITE DES INSTALLATIONS ET DE L'ENVIRONNEMENT DU CENTRE D'ETUDES DE SACLAY J.P. HULOT, J. CASTRI, G. ROBINET, R. TRAVAILLON. (FRANCE)	471
FAST AND SENSITIVE DETERMINATION OF SR-90 AND BR-89 ACTIVITY IN MILK BY ION-CHROMATROGRAPHY AND LIQUID SCINTILLATION VERENA FIGUEIREDO, A. HERRMANN. (SWITZERLAND)	475
ETUDE DE COMPTEURS MINIATURES POUR LA DOSIMETRIE INDIVIDUELLE DES NEUTRONS J. BARTHE, M. MOURGUES, J.M. BORDY, B. BOUTRUCHE, T. LAHAYE, G. PORTAL. (FRANCE)	479

DEVELOPPEMENTS D'UNE ANALYSE AUTOMATIQUE D'IMAGE POUR LE COMPTAGE DE FILMS DOSIMETRIQUES F. BERGER, D. KLEIN, R. BARILLON, A. CHAMBAUDET. (FRANCE)	483
BACKGROUND TRACKS IN CR-39 SSNTD SHEETS: THEIR CONTROL AND PREDICTION THROUGH AN INTERPLAY OF ETCHING PARAMETERS ARUN MORESHWAR BHAGWAT, G.R. NAIK, S. THAMPAN, K. RUDRAN, V.B. JOSHI, M.R. IYER. (INDIA)	487
A COMPACT SYSTEM FOR NEUTRON SPECTROMETRY JEAN-FRANCOIS VALLEY, A. AROUA, M. GRECESCU, P. LERCH, S. PRETRE. (SWITZERLAND)	491
FAST NEUTRON DOSIMETRY WITH CR-39 PLASTICS PLATE TAKAO TSURUTA, T. NIWA. (JAPAN)	495
FIXED RADIATION PROTECTION CHANNELS ON EDF PWR GILLES CHAMPION, JEAN-MARIE HOUIN. (FRANCE)	499
AN ALPHA ACTIVITY IMAGING MONITOR SYSTEM FOR RAPIDLY DETECTING Pu CONTAMINATION TAKAO IIDA, YUDIMASA IKEBE, TAKEO NISHIYA, TAKESHI OGURA, TAMOTSU NOMURA. (JAPAN)	503
INTELLIGENT DOSE RATE DETECTORS FOR RADIATION MONITORING IN AUTOMATIC MEASURING NETWORKS W. RIECK, H. FAATZ, J. FROWEIN, B. HOFFMANN, M. IWATSCHENKO-BORHO, H. SCHLEICHER. (GERMANY)	507
HEALTH PHYSICS INSTRUMENTATION - A PROGRESS REPORT RUPPRECHT MAUSHART. (GERMANY)	511
CHARACTERISTICS OF TWO GAMMA-RAY SURVEY METERS USED FOR INFLIGHT DOSE EQUIVALENT RATE MEASUREMENTS D. REGULLA, J. DAVID, U. LAUTERBACH, W. PEBARA. (GERMANY)	515
MULTI-COUNTER SYSTEM FOR LOW LEVEL MEASUREMENTS OF ENVIRONMENTAL SAMPLES H. SCHLOSSER, U. ENGEL, M. RINGLING, M. IWATSCHENKO-BORHO. (GERMANY)	516
THE RESPONSE OF CONTAMINATION MONITORS TO NEARLY 600 RADIONUCLIDES MAX HEINZELMANN, G.H. SCHNEPEL. (GERMANY)	520
A NEW CAM SYSTEM ON THE BASIS OF PROPORTIONAL COUNTER TUBES E. FRENZEL. (GERMANY)	524
POSSIBILITIES OF THE MICROELECTROPHORESIS TECHNIQUE FOR THE ASSESSMENT OF RISK AT LOW-DOSE IRRADIATION I.V. FILIPPOVICH, V.A. TRONOV, M.F. DENISENKO, T.M. ALFYEROVA, E.V. GRINKO. (U.S.S.R.)	528

SESSION 6	ICRP RECOMMENDATION 1990 -I	
	RECOMMANDATION ICRP 1990 -I	
	ICRP 60 RECOMMENDATIONS	532
	DH. BENINSON. (ARGENTINA)	
	ICRP COMMITTEE 1: THE CONTINUING SAGA OF ESTIMATES OF RISK FOR RADIATION INDUCED CANCER	533
	WARREN K. SINCLAIR. (USA)	
SESSION 7A	BIOLOGICAL EFFECTS OF RADIATION -I	
	EFFETS BIOLOGIQUES DES RAYONNEMENTS -I	
	MORTALITY UNDER AGE 25 AROUND SIX FRENCH NUCLEAR SITES	541
	CATHERINE HILL, AGNES LAPLANCHE. (FRANCE)	
	CHILDHOOD LEUKAEMIA AROUND NUCLEAR FACILITIES IN GREAT BRITAIN	545
	R. WAKEFORD, K. BINKS, A. SLOVAK. (UNITED KINGDOM)	
	EPIDEMIOLOGY OF LEUKEMIA AMONG NUCLEAR WORKERS: A QUANTITATIVE ANALYSIS OF RESULTS FROM 8 PUBLISHED STUDIES	549
	GREGG WILKINSON, NANCY A. DREYER. (U.S.A.)	
	ETUDE EPIDEMIOLOGIQUE DE LA MORTALITE D'UN GROUPE DE MINEURS D'URANIUM EN FRANCE	550
	M. TIRMARCHE, A. RAPHALEN, F. ALLIN, J. CHAMEAUD, P. BREDON. (FRANCE)	
	BILAN DE LA MORTALITE PAR CANCER DES TRAVAILLEURS DU NUCLEAIRE DU CEA ET DE LA COGEMA DE 1969 A 1986	555
	M. TIRMARCHE, A. RAPHALEN, F. ALLIN, P. LE GUEN. (FRANCE)	
	GENDER SPECIFIC RISKS FOR FEMALE IONIZING RADIATION WORKERS	559
	R. MCFADDEN. (CANADA)	
	ETUDES EPIDEMIOLOGIQUES RELATIVES AUX CANCERS CONCERNANT LA HAGUE ET SA REGION	563
	PIERRE THOMAS. (FRANCE)	
	CONSISTENCY OF EXTERNAL DOSIMETRY IN EPIDEMIOLOGIC STUDIES OF NUCLEAR WORKERS	567
	JACK FIX, ETHEL S. GILBERT. (U.S.A.)	
	EFFECT OF CHITOSAN AND ALGINATE ON THE BIOKINETICS OF RADIOSTROTIUM IN RATS	571
	Y. NASHIMURA, K.Y. KIM, I.S. WUI, K. WATARI, K. IMAI, J. INABA. (KOREA)	
	NONSPECIFIC CELLULAR RESISTANCE DISORDERS INDUCED BY LOW DOSES OF RADIATION	578
	I. VOLTCHER, E. KOSTYUSHOV, L. FILYOV, V. DYACHEK, I. IZYUMTSEV, A. TYAPTIN, I. POPOV, YU. MEDVEDEV, L. GONCHAROVA. (U.S.S.R)	

**SESSION 7B EDUCATION AND TRAINING -I
 FORMATION EN RADIOPROTECTION -I**

RADIATION PROTECTION - IS IT SCIENCE ?	579
BRUCE HARTLEY. (AUSTRALIA)	
TRAINING AND RETRAINING OF RADIATION PROTECTION TECHNICIANS	583
LISBETH WARMING, J. SOGAARD-HANSEN, B. LAURIDSEN, P. HEDEMANN JENSEN. (DENMARK)	
COST EFFECTIVE RADIATION PROTECTION FOR SCHOOLS AND COLLEGES IN THE UNITED KINGDOM	587
KEITH BOWKER. (UNITED KINGDOM)	
EDUCATIVE HEALTH PHYSICS	591
R.J. VETTER, M.C. O'RIORDAN. (U.S.A)	
COMPARAISON DES RISQUES DES DIVERSES ENERGIES POUR LA PRODUCTION D'ELECTRICITE	592
M. BERTIN, D. HUBERT, J. LALLEMAND, J. ROLLIN. (FRANCE)	
RADIATION PROTECTION TRAINING AT ELECTRICITE DE FRANCE	596
EVELYNE GUINARD. (FRANCE)	
RADIATION SAFETY TRAINING FOR URANIUM WORKERS	600
BHAWANI PATHAK. (CANADA)	
RADIATION PROTECTION TRAINING AT IEN-CNEN	604
PATRICIA WIELAND FAJARDO. (BRAZIL)	
PRESENT SITUATION AND ROLE OF THE RADIATION CONTROL EDUCATION FOR HEALTH PERSONNEL BEFORE LEAVING SCHOOL	608
TAKEO ORITO, S. KOGA, S. SUZUKI, M. NAKAMURA. (JAPAN)	
EDUCATIONAL PROGRAMME ON RADIATION PROTECTION FOR VETERINARY MEDICINE SPECIALISTS	612
G. DJURIC, D. POPOVIC. (YUGOSLAVIA)	

**SESSION 7C INSTRUMENTATION AND MEASUREMENT TECHNIQUES -II
 INSTRUMENTATION ET TECHNIQUES DE MESURE -II**

DEVELOPMENT OF AN EFFECTIVE DOSE EQUIVALENT DETECTOR HAVING ANGULAR RESPONSE OF HUMAN BODIES	616
MASAHIRO TSUTSUMI, K. SAITO, S. MORIUCHI. (JAPAN)	
ETUDE D'UNE SOURCE DE RAYONNEMENT SIMULANT DES SPECTRES REALISTES DE NEUTRONS POUR L'ETALONNAGE D'APPAREILS DE RADIOPROTECTION	620
J.L. CHARTIER, F. POSNY, M. BUXEROLLE. (FRANCE)	
A RADON EXPOSURE CHAMBER IN HONG KONG	624
JOHN LEUNG, JIA D., MAN-YIN W. TSO. (HONG KONG)	
A CONTROL SYSTEM FOR STANDARD ALPHA AND BETA RADIOACTIVE SOURCES	628
SIMONE K. DIAS, LINDA CALDAS. (BRAZIL)	

SIMULTANEOUS MONITORING OF ALPHA AND BETA EMITTING AEROSOLS IN THE ENVIRONMENT	632
M. IWATSCHENKO-BORHO, U. ENGEL, A. GAGEL, W. KIESEWETTER, T. NAATZ, T. STEINKOPFF. (GERMANY)	
AN APPROVED PERSONAL DOSIMETRY SERVICE BASED ON AN ELECTRONIC DOSEMETER	636
T.O. MARSHALL, E.A. POOK, D.T. BARTLETT, J. HALLAM. (UNITED KINGDOM)	
GRAPHITE MIXED CASO4 : DY TL DOSEMETERS FOR BETA RADIATION DOSIMETRY	640
LETICIA CAMPOS. (BRAZIL)	
A PARALLEL PLATE IONIZATION CHAMBER FOR ELECTRON DOSIMETRY	644
CLEBER NOGUEIRA DE SOUZA, LINDA CALDAS. (BRAZIL)	
THORIUM BIOASSAY OF MINERAL SANDS WORKERS	648
G.S. HEWSON, J.J. FARDY. (AUSTRALIA)	
THE N-16 GAMMA RADIATION RESPONSE OF GEIGER-MUELLER TUBES	652
DAVID J. ALLARD, A.M. NAZARALI, G.E. CHABOT. (U.S.A.)	
L'ENVIRONNEMENT ET LA SURVEILLANCE DE LA RADIOACTIVITE DANS L'AIR	656
B. ROTTNER. (FRANCE)	
COMPARAISON DE TECHNIQUES DE MESURE DU RADON 222 (COMPTEUR PROPORTIONNEL, DIODE SILICIUM (P.I.N.) ET DETECTEURS SOLIDES DE TRACES NUCLEAIRES)	658
DIDIER KLEIN, R. BARILLON, A. CHAMBAUDET. (FRANCE)	
AIR CONTAMINATION MEASUREMENTS CONNECTED WITH THE THERAPEUTIC USE OF I-131	662
H. KRISTUFEK, E. OGRIS, H. AIGINGER. (AUSTRIA)	
LEVELS OF POLONIUM-210 IN SOME BEVERAGES AND IN TOBACCO	666
C. COLANGELO, M.R. HUGUET, M.A. PALACIOS, A.A. OLIVEIRA. (ARGENTINA)	
DOSE EQUIVALENT ESTIMATE OF WORKS IN A BRAZILIAN MONAZITE SAND PLANT	670
CESAR NEY, L. TAUHATA, D.S. OLIVEIRA FILHO. (BRASIL)	
MESURES DANS UNE MINE D'URANIUM DE LA GRANULOMETRIE DES AEROSOLS ET DES DESCENDANTS DU RANDON	673
D. BOULAUD, J.C. CHOUARD. (FRANCE)	
SESSION 7D OCCUPATIONAL EXPOSURE -I: INDUSTRIAL INSTALLATIONS EXPOSITIONS PROFESSIONNELLES -I: INSTALLATIONS INDUSTRIELLES	
GESTION DE LA DOSIMETRIE DES TRAVAILLEURS D'ENTREPRISES EXTERIEURES	677
PHILIPPE ROLLIN, CHRISTIAN LEFAURE. (FRANCE)	

NUCLEAR POWER IN SWEDEN - DOSES AND ACTIONS JACK VALENTIN, P. HOFVANDER, C. HAGG, L. MALMQVIST, B.A. PERSSON. (SWEDEN)	681
SAFETY STATUS OF RADIATION WORKERS HANDLING RADIOLUMINOUS PAINT P.K. GAUR, G. SADAGOPAN, G. VENDATARAMAN, K. RUDRAN. (INDIA)	685
IMPACT DU COMBUSTIBLE MOX SUR LA DOSIMETRIE PROFESSIONNELLE ALAIN GLOAGUEN, CHRISTIAN THEZEE. (FRANCE)	689
SPECIFICATION DE BLINDAGE PRIMAIRE ET SECONDAIRE POUR LES SALLES DE RADIOGRAPHIE INDUSTRIELLE MUNIES D'IRIDIUM 192 SELON LES LIMITES DE DOSES EFFECTIVES ANNUELLES D'ICRP 60 J.M. LEGARE. (CANADA)	694
RETROSPECTIVE ANALYSIS OF THE EVOLUTION OF THE PWRs OCCUPATIONAL EXPOSURE MARIE BENEDITTINI, ALAIN BRISSAUD, JEAN-LUC TROMBINI. (FRANCE)	698
FRENCH NUCLEAR POWER PLANTS ACCUMULATED DOSE INTERNATIONAL COMPARISONS JACQUES STAIMESSE, A. BRISSAUD, TROMBINI. (FRANCE)	702
PROPERTIES OF AEROSOL FLOATING IN THE AIR IN A NUCLEAR POWER PLANT WORKPLACE ENVIRONMENT HIDEAKI KARASAWA, MAKOTO FUNABASHI, MAKATO ITO. (JAPAN)	706
SESSION 8A BIOLOGICAL EFFECTS OF RADIATION -II EFFETS BIOLOGIQUES DES RAYONNEMENTS -II	
RISK MODELS FOR ESTIMATING LIFETIME CANCER PROBABILITY: ALTERNATIVE TO RELATIVE RISK MODELS BY UNSCEAR, ICRP MICHIAKI KAI, T. KUSAMA. (JAPAN)	710
EPIDEMIOLOGY OF PLUTONIUM WORKERS GEORGE VOELZ, L.D. WIGGS, W.A. GALKE. (U.S.A)	714
INFLUENCE OF TIME AND DOSE RATE ON CANCER RISK FROM INTERNALLY DEPOSITED RADIONUCLIDES OTTO G. RAABE. (U.S.A)	718
RAYONNEMENTS, CANCERISATION HUMAINE ET RADIORESISTANCE MONIQUE VUILLAUME, ERIC QUEINNEC. (FRANCE)	722
TRANSFER OF RISK COEFFICIENTS ACROSS POPULATIONS LEN RASMUSSEN, CHRIS POMROY. (CANADA)	727
AUGMENTATION OF PROLIFERATIVE RESPONSES OF MOUSE SPLENCYTES BY LOW-DOSE X-RAY IRRADIATION K. ISHII, MIYUKI AYUZAWA, JUN MISONOH. (JAPAN)	732

STUDY OF LEUKOCYTIC ENZYMES ACTIVITY ENFLUENCED BY IONIZING IRRADIATION SNEZANA MILACIC, M. JANCIC, S. DODIC. (YUGOSLAVIA)	736
PERCUTANEOUS ABSORPTION OF TRITIATED OIL AND DOSIMETRIC CONCERNS AKHILESH TRIVEDI. (CANADA)	743
FUNCTIONAL STATE OF ANTIOXIDANT SYSTEM UNDER INFLUENCE OF RADIATION LOW DOSES I.V. VOLTCHER, E.V. KOSTYUSHOV, L.L. GONCHAROVA, I. IZYUMTSEV, V. DYACHEK, A. TYAPTIN, I. POPOV, S.A. KALIKANOV, L.V. FILYOV. (U.S.S.R)	747
LOCALISATION MOLECULAIRE DE L'AMERICIUM, DU TECHNETIUM ET DU CESIUM CHEZ DES ANIMAUX MARINS COMESTIBLES - LEUR COMPORTEMENT METABOLIQUE ET SES CONSEQUENCES. J. PIERI, F. GOUDARD, M.C. MILCENT. (FRANCE)	751
SESSION 8B NIR -I: WORKPLACE AND PUBLIC EXPOSURE RNI -I: TRAVAIL ET EXPOSITION DU PUBLIC	
MANAGEMENT OF RADIO FREQUENCY RADIATION EXPDSURES IN TELECOM AUSTRALIA KEN JOYNER, B. HOCKING. (AUSTRALIA)	755
RESULTS FROM AN AUSTRALIAN SOLAR UVR MEASUREMENT NETWORK AND IMPLICATIONS FOR RADIATION PROTECTION POLICY COLIN ROY, PETER GIES. (AUSTRALIA)	759
EXPOSURE OF ONTARIO WORKERS TO RADIOFREQUENCY FIELDS FROM DIELECTRIC HEATERS MAURICE BITRAN, JOHN NISHIO, DAVID CHARRON. (CANADA)	763
E.L.P. MAGNETIC FIELD DISTRIBUTION AROUND POWER LINES IN AN URBAN AREA BRIAN HEATON, H.M. MCCALLUM. (SCOTLAND)	767
OCULAR EXPOSURE TO ULTRAVIOLET AND VISIBLE RADIATION FROM LIGHT SOURCES M. HIETANEN. (FINLAND)	771
TRESHOLD LIMIT VALUES FOR ULTRAVIOLET RADIATION MEASURED FOR SOURCES USED IN RESEARCH EQUIPMENT AND SOME CASES OF OVEREXPOSURE TO UV RADIATION A.G. RICHARDS. (UNITED KINGDOM)	775
RADIO FREQUENCY RADIATION (RFR) EXPOSURES FROM MOBILE PHONES KEN JOYNER (A), V. LUBINAS (A), M.P. WOOD (A), J. SARIBALAS (A), J.A. ADAMS (NZ). (AUSTRALIA, NEW ZEALAND)	779
OBSERVED OCCUPATIONAL RADIO FREQUENCY AND MICROWAVE RADIATION EXPOSURES DURING SURVEYS AROUND A FEW SCIENTIFIC, INDUSTRIAL AND MEDICAL SOURCES R.N. SACHDEV, N.A. INGLE, G. SWARUP, K.K. RAJAN. (INDIA)	783

A STUDY ON THE RELATIONSHIP BETWEEN INCOMING SOLAR UV RADIATION AND CLOUD COVER	787
VIJAY DAOO. (INDIA)	
PERSONAL DOSIMETRY OF SOLAR UVB USING POLYSULPHONE FILM	791
PETER GIES, COLIN ROY, E. HERLIHY, J. RIVERS. (AUSTRALIA)	
UV RADIATION; SOURCES, EFFECTS AND RISKS OF HUMAN AND ENVIRONMENTAL EXPOSURE	795
G.J. EGGINK, H. SLAPER. (THE NETHERLANDS)	
LES EFFETS DES CHAMPS ELECTROMAGNETIQUES DE 50-60 HZ: BILAN ET PERSPECTIVES DE SANTE PUBLIQUE POUR LE QUEBEC	799
P. LEVALLOIS, P. LAJOIE, D. GAUVIN. (CANADA)	
SESSION 8C	RADIATION ACCIDENTS -III: MEDICAL ASPECTS
	ACCIDENTS RADIOLOGIQUES -III: ASPECTS MEDICAUX
CHROMOSOMAL ABERRATION ANALYSES OF BYELORUSSIAN CHILDREN EXPOSED TO CHERNOBYL FALLOUT	801
SISKO SALOMAA, A. KOIVISTOINEN, W. PAILE, T. RAHOLA, T. RYTOMAA. (FINLAND)	
STUDY OF AN ACCIDENTAL EXPOSITION OF THREE WORKERS DURING A GAMMAGRAPHY WITH IR-192 SOURCE	805
SANDRA APARECIDA BELLINTANI, ADELIA SAHYUN, MARIA ELISABETH GRACIOTTI, R. SANTOS, ROBERTO ALCARES. (BRAZIL)	
SUIVI MEDICAL ET SANITAIRE DE POPULATIONS VICTIMES DE L'ACCIDENT DE TCHERNOBYL: PRESENTATION D'UNE EXPERIENCE FRANCO UKRAINIENNE	806
ALEXANDRA MOUTET, M.L. SIMONET, M. VALENTY, C. BENSIMON, N. PARMENTIER, J.C. NENOT, P. HUBERT, C. PARMENTIER, M. SCHLUMBERGER. (FRANCE)	
OVEREXPOSURE CASES ON THE EXTREMITIES IN RADIOLOGICAL ACCIDENTS	810
TOMOKO KUSAMA, Y. BESSHO, E. KONISHI, MICHIAKI KAI, YASUO YOSHIZAWA, M. OHTA, M. KATUMASA. (JAPAN)	
RADIOTOXICOLOGICAL ASSESSMENT OF BURNS CONTAMINATED BY NITRIC SOLUTION OF PLUTONIUM	814
J. PIECHOWSKI, J. BENOIT, J. MERCIER, P. THOMAS, J.C. HARDUIN. (FRANCE)	
AIDE INFORMATISEE A L'ORGANISATION DES SECOURS MEDICAUX SUR SITE DANS LE CADRE D'UN ACCIDENT DE GRANDE AMPLEUR EN CENTRALE NUCLEAIRE	818
MARC TEISSIER. (FRANCE)	
EFFECTS OF POWDERED OYSTER SHELL ON DECORPORATION OF PLUTONIUM	822
SATOSHI FUKUDA, HARUZO IIDA. (JAPAN)	

SESSION 8D OCCUPATIONAL EXPOSURE -II: RESEARCH AND FUEL
INSTALLATIONS
EXPOSITIONS PROFESSIONNELLES -II: INSTALLATIONS DE
RECHERCHE ET DE FABRICATION DE COMBUSTIBLE

RADIOLOGICAL PROTECTION AT PARTICLE ACCELERATORS : AN
OVERVIEW 825
RALPH THOMAS. (U.S.A.)

RADIATION PROTECTION AT THE CERN LARGE ELECTRON POSITRON
COLLIDER (LEP) 829
MANFRED HOFERT, A. FASSO, L. GOEBEL, G.R. STEVENSON, P.
SCHMIDT. (SWITZERLAND)

PHOTONEUTRON LEAKAGE FROM MEDICAL ACCELERATORS: A
COMPREHENSIVE APPROACH TO PATIENT AND PERSONNEL DOSE
MEASUREMENT 833
F. D'ERRICO, G. CURZIO. (ITALY)

EMPLOYEE DOSE REDUCTION AT BRITISH NUCLEAR FUELS PLC 837
A.H. FISHWICK, J.L. FINLAYSON, R.D. JAMES. (UNITED
KINGDOM)

DOSE AND DOSE RATE MEASUREMENTS AROUND THE SIS 841
JOHANNES GEORG FESTAG. (GERMANY)

CONTAMINATION BY TRITIUM OF WATERS AND CONCRETE IN A
RESEARCH REACTOR CONTAINMENT DUE TO LEAKAGE OF HEAVY
WATER 845
MASAMI FUKUI. (JAPAN)

REDUCTION OF EXPOSURES ARISING DURING THE MANUFACTURE AND
DISTRIBUTION OF RADIOACTIVE PRODUCTS FOR HEALTHCARE,
RESEARCH AND INDUSTRY 849
RICHARD WYNNE DAVIES. (ENGLAND)

VERY LOW ENERGY BETA MEASUREMENTS IN TRITIUM CONTAMINATED
PARTS 853
S.K. AL-ARBI, B.M. BAHAL, U.M. EL-GHAWI, A.A. GULAK, H.H
ENBIA. (LYBIA)

EXPERIENCES LIEES A L'ÉVALUATION DU FACTEUR DE REMISE EN
SUSPENSION D'AEROSOLS DE PLUTONIUM 857
G. PESCAIRE, J. MOLL. (FRANCE)

SESSION 9A BIOLOGICAL EFFECTS OF RADIATION -III
EFFETS BIOLOGIQUES DES RAYONNEMENTS -III

GAMMA RADIATION INDUCED ALTERATIONS IN THE ULTRASTRUCTURE
OF PANCREATIC ISLET, METABOLISM AND ENZYMES IN WISTAR
RAT 860
JAYASHREE VIJAY DAOO, S.A. SURYAWANSHI. (INDIA)

LIFE-SPAN HEALTH EFFECTS OF RELATIVELY SOLUBLE FORMS OF
INTERNALLY DEPOSITED BETA-EMITTING RADIONUCLIDES 864
BRUCE BOECKER, B. A. MUGGENBURG, F. F. HAHN, K.J. NIKULA,
W.C. GRIFFITH. (U.S.A.)

PRELIMINARY EARLY EVALUATION OF RADIATION ACUTE SYNDROME SEVERITY IN AN ANIMAL MODEL	868
J.C. GIMENEZ, N.B. NASAZZI, M.R. TAJA, C. NAGLE, D. DUBNER, C. DI RIZZIO. (ARGENTINA)	
CLASS I AND II HLA ANTIGEN EXPRESSION AFTER A 10 GY-4 HOUR TOTAL BODY IRRADIATION	872
J.M. COSSET, C. RAFFOUX, M.P. CHAILLET, G. SOCIE, J.Y. FOLLEZOU, T. GIRINSKY. (FRANCE)	
CHRONIC IONIZING RADIATION EXPOSURE AS A TUMOR PROMOTER IN MOUSE SKIN	876
R.E.J. MITCHEL, AKHILESH TRIVEDI. (CANADA)	
GENE CONVERSION IN YEAST AS A FUNCTION OF LINEAR ENERGY TRANSFER (LET) FOR LOW-LET RADIATION	880
JOHN JOHNSON, P. UNRAU, D.P. MORRISON. (U.S.A.)	
TAURINE AS A BIOLOGICAL DOSEMETER. ITS DETERMINATION IN PHYSIOLOGICAL SAMPLES BY REVERSED PHASE HIGH-PERFORMANCE LIQUID CHROMATOGRAPHY.	884
D. DUBNER, M. FERNANDEZ. (ARGENTINA)	
RESPONSES OF GAMMA IRRADIATED MICE TO ALPHA-TOCOPHEROL	888
N. ELIOSOFF, D. DUBNER, P. GISONE. (ARGENTINA)	
CYTOGENETICAL EVALUATION OF A NEW ANIMAL MODEL FOR RADIOBIOLOGICAL STUDIES	892
N.B. NASAZZI, M.R. TAJA, C. NAGLE, J.C. GIMENEZ. (ARGENTINA)	
THE EFFECT OF DOSE PROTRACTION ON THE INCIDENCE OF LUNG CARCINOMAS IN BEAGLE DOGS WITH INTERNALLY DEPOSITED BETA-EMITTING RADIONUCLIDES	896
W.C. GRIFFITH, B. B. BOECKER, F. F. HAHN, B. A. MUGGENBURG, M. B. SNIPES. (U.S.A.)	
THE EFFECT OF ISOTOPE ON THE DOSIMETRY OF INHALED PLUTONIUM OXIDE	900
RAYMOND GUILMETTE, ALBERT W. HICKMAN, WILLIAM C. GRIFFITH. (U.S.A.)	
EFFETS DE L'IRRADIATION GAMMA SUR LES CELLULES MESENCEPHALIQUES ET STRIATALES EN CULTURE	
HERVE COFFIGNY, M. BEAUVALLET, L. COURT. (FRANCE)	
ETUDE DE LA TOXICOCINETIQUE DU TECHNETIUM 95M CHEZ LE RAT NOUVEAU NE, ADULTE PENDANT LA GESTATION ET LA LACTATION	908
Y. ARCHIMBAUD, J.L. PONCY, M. COGNEAU, R. MASSE. (FRANCE)	
INFLUENCE DU DEBIT DE DOSE ET DE L'AGE A L'IRRADIATION SUR LES EFFETS CANCEROGENES DU RAYONNEMENT GAMMA CHEZ LE RAT SPRAGUE-DAWLEY	912
MICHELE-ELIZABETH MORIN. (FRANCE)	

COMPARISON OF THE EFFECTS OF INHALED PuO ₂ -239 AND BETA-EMITTING RADIONUCLIDES ON THE INCIDENCE OF LUNG CARCINOMAS IN LABORATORY ANIMALS	916
F.F. HAHN, W. C. GRIFFITH, B. B. BOECKER, B. A. MUGGENBURG, D. L. LUNDGREN. (U.S.A.)	
IMPROVEMENTS IN LUNG LAVAGE TO INCREASE ITS EFFECTIVENESS IN REMOVING INHALED RADIONUCLIDES	920
B.A. MUGGENBERG, R. A. GUILMETTE, L. M. ROMERO, J. A. MEWHINNEY. (U.S.A.)	
EFFECTS OF A WHOLE BODY GAMMA IRRADIATION ON GABA REPARTITION IN INFANT RATS CEREBELLUM AND HIPPOCAMPAL FORMATION	924
FLORENCE MENETRIER, Y. VERNONIS, L. COURT. (FRANCE)	
SESSION 9B	
NIR -II: STANDARDS AND EXPOSURE ASSESMENT	
RNI II: NORMES ET DÉTERMINATION DE L'EXPOSITION	
GUIDELINES FOR EXPOSURE TO SUB-RADIOFREQUENCY ELECTRIC AND MAGNETIC FIELDS	925
DAVID SLINNEY, M. PATTERSON. (U.S.A)	
ON THE BOUNDARY BETWEEN IONIZING AND NON-IONIZING RADIATION	929
LARS PERSSON. (SWEDEN)	
BASIC CRITERIA FOR ELF-STANDARDS	933
J. BERNHARDT. (GERMANY)	
PROPOSAL FOR CHANGING THE LASER EXPOSURE LIMITS FOR EXTENDED SOURCE VIEWING	937
DANIEL COURANT (F), D.H. SLINNEY (USA), W. MARSHALL (USA), L. COURT (F). (FRANCE, U.S.A.)	
CURRENT AND PLANNED ACTIVITIES OF THE IRPA - INTERNATIONAL NON-IONIZING RADIATION COMMITTEE	941
A DUCHENE. (FRANCE)	
DEVELOPPEMENT D'UN APPAREIL PORTATIF A LECTURE DIRECTE POUR L'EVALUATION DES CHAMPS ELECTRIQUES ET MAGNETIQUES AUX FREQUENCES EXTREMEMENT BASSES	945
LAMBERT LALIBERTE, B. CARON, R. SYLVESTRE. (CANADA)	
DOMESTIC MAGNETIC FIELDS PROTOCOLS, MEASUREMENTS AND RESULTS	947
A.T. WILSON, R.J. OWEN. (AUSTRALIA)	
MAGNETIC FIELD EXPOSURE ASSESSMENT BY WIRE CODING	951
VINCENT DELPIZZO, JOANNA BORGHESI. (AUSTRALIA)	
CURRENT STATUS OF SOVIET NIR STANDARDS	955
M SHANDALA. (USSR)	

SESSION 9C RADIATION ACCIDENT -IV: EMERGENCY PLANNING
 ACCIDENTS RADIOLOGIQUES -IV: PLANIFICATION D'URGENCE

L'ORGANISATION DES POUVOIRS PUBLICS ET DES SECOURS EN FRANCE EN CAS D'ACCIDENT NUCLEAIRE C. GUIZARD. (FRANCE)	956
EMERGENCY PLANNING AND EXERCISING WITHIN BRITISH NUCLEAR FUELS PLC N.J. OAKES, N.J.W. McPHAIL. (UNITED KINGDOM)	960
A TABLE TOP EXERCISE AND WORKSHOP J.R.A. LAKEY. (UNITED KINGDOM)	964
COORDINATED PROTECTION OF THE POPULATION IN EMERGENCIES IN SWITZERLAND: THE NATIONAL EMERGENCY OPERATIONS CENTRE (NAZ) AND THE EMERGENCY ORGANISATION RADIOACTIVITY (EOR) HANS H. BRUNNER. (SWITZERLAND)	968
THE NEW EMERGENCY ORGANIZATION IN FRENCH POWER PLANTS BERNARD HOUPIN. (FRANCE)	972
BASES TECHNIQUES DES PLANS PARTICULIERS D'INTERVENTION DES SITES NUCLEAIRES J.P. MAIGNE, J. COLLINET. (FRANCE)	976
MAKING UP DECISION SUPPORT SYSTEM IN NUCLEAR EMERGENCY - FRAMEWORK OF DECISIONS YOSHIYUKI NAKASHIMA, T. SUZUKI, A. NAGAI. (JAPAN)	981
SPACE-TIME CONCEPT FOR ESTABLISHMENT OF INTERVENTION LEVELS FOR OFF-SITE RADIATION EMERGENCIES V.K. GUPTA, T.N. KRISHNAMURTHI, D. KRISHNAN, K.K. NARAYANAN, A.R. SUNDARARAJAN. (INDIA)	985
THE BRAZILIAN RADIOLOGICAL ACCIDENTS ANALYSIS METHODOLOGY IN INDUSTRIAL GAMMA RADIOGRAPHY FRANCISCO CESAR AUGUSTO DA SILVA, L. TAUHATA. (BRASIL)	989
DECONTAMINATION EXERCISE AT A GENERAL HOSPITAL BRIAN HEATON. (SCOTLAND)	994
AGRICULTURE, ENVIRONNEMENT ET NUCLEAIRE G. GRIPERAY, R. COULON. (FRANCE)	998
DACFOOD - UN SYSTEME D'AIDE A LA DECISION EN CAS DE CONTAMINATION DE LA CHAINE ALIMENTAIRE ALAIN DESPRES, ANTOINE DIAZ, DOMINIQUE SOULTAGES. (FRANCE)	1002
ETUDE SUR LE COMPORTEMENT EVENTUEL DES BENEVOLES APPELES A EFFECTUER LA DISTRIBUTION DE PILULES D'IODE EN CAS D'ACCIDENT A LA CENTRALE NUCLEAIRE DE GENTILLY II RAYMOND CORRIVEAU. (CANADA)	1006

**SESSION 9D OCCUPATIONAL EXPOSURE -III: INTERNAL EXPOSURE
EXPOSITIONS PROFESSIONNELLES -III: EXPOSITION
INTERNE**

ETUDE DE L'EXPOSITION INDUSTRIELLE A DES OXYDES D'URANIUM (UO₂-U₃O₈) METHODES ET RESULTATS	1010
E. ANSOBORLO, P. BERARD, J. CHALABREYSSE, M.H. HENGE-NAPOLI, B. QUESNE. (FRANCE)	
INTERNAL EXPOSURE IN FRENCH NUCLEAR POWER PLANTS : 10 YEARS ON	1014
CHRISTIAN CHEVALIER, M. GONIN. (FRANCE)	
ASSESSMENT OF INTAKES AND RADIATION DOSES FOLLOWING EXPOSURE TO TRITIATED WATER	1018
KAMALA RUDRAN, J.V. SAWANT, S. THAMPAN, V.S. BANGERA. (INDIA)	
EXPOSURE TO RADIOACTIVE AEROSOLS IN MINING AND MILLING OPERATIONS: THE IMPORTANCE OF AC-227 AND PA-231	1022
ROBERTO VICENTE, JOSE CLAUDIO DELLAMANO, SANDRA APARECIDA BELLINTANI. (BRASIL)	
ANNUAL DOSE DISTRIBUTIONS FOR THE OLYMPIC DAM OPERATIONS	1023
JIM HONDROS. (AUSTRALIA)	
IAEA - USSR WHOLE BODY COUNTER INTERCOMPARISON	1027
RICHARD GRIFFITH, R. OUVARD, V. BAD'IN, S. ULANOVSKY, A. KOVTUN, I.A. LIKHTAREV, L.A. LITVINETS, V.S. REPIN, O.N. PEREVOZNIKOV, V.A. PARRHOMENKO, F. STEGER. (AUSTRIA)	

TABLE DES MATIERES - TABLE OF CONTENTS

SESSION 11	PLENARY: RADIATION PROTECTION - IONIZING AND NON IONIZING RADIATION SÉANCE PLÉNIÈRE: PROTECTION RADIOLOGIQUE - RADIATIONS IONISANTES ET NON IONISANTES	
	REVIEW OF THE EVIDENCE FOR CANCER PROMOTION FROM EXPOSURE TO 50-60 HZ MAGNETIC FIELDS M. REPACHOLI. (AUSTRALIA)	1031
	THE WORK OF COMMITTEE 4 OF ICRP ROGER H. CLARKE. (UNITED KINGDOM)	1039
SESSION 12A	PROTECTION CONCEPTS, POLICIES AND STANDARDS -I CONCEPTS, POLITIQUES ET NORMES DE RADIOPROTECTION - I	
	THE NEW ICRP RECOMMENDATIONS: HOW WILL THEY BE TRANSLATED INTO PRACTICE? OSVALDO ILARI, A. GONZALEZ, G. HASON, C. BORRAS, E. BOUTRIF. (FRANCE)	1043
	APPLICATIONS DES RECOMMANDATIONS DE LA CIPR. UTILISATION DES CONTRAINTES ET DES NIVEAUX DANS DES CAS CONCRETS HENRI JAMMET, A. SUGIER. (FRANCE)	1047
	THE REVISED INTERNATIONAL COMMISSION ON RADIOLOGICAL PROTECTION (ICRP) DOSIMETRIC MODEL FOR THE HUMAN RESPIRATORY TRACT WILLIAM J. BAIR. (U.S.A)	1053
	IMPLICATIONS OF 1990 ICRP RECOMMENDATIONS ON RADIATION PROTECTION PRACTICES IN THE MINERAL SANDS INDUSTRY GEORGE KOPERSKI. (AUSTRALIA)	1057
	LES NOUVELLES GRANDEURS OPERATIONNELLES DE L'ICRU ET LEUR IMPACT SUR LES TECHNIQUES DE DOSIMETRIE EN RADIOPROTECTION G. PORTAL. (FRANCE)	1061
	MESURE DES NOUVELLES GRANDEURS OPERATIONNELLES A L'AIDE DES APPAREILS DE RADIOPROTECTION DESTINES A LA SURVEILLANCE DES ZONES DE TRAVAIL ET A LA SURVEILLANCE INDIVIDUELLE R. PRIGENT, J. CHARY, M. CHEMTOB, Y. HERGAUT, P. LEBOULEUX. (FRANCE)	1065
	THE PRACTICAL IMPLICATIONS OF THE NEW ICRP ANNUAL DOSE LIMIT AT OLYMPIC DAM OPERATIONS JIM HONDROS. (AUSTRALIA)	1069
	DOSE LIMITS REDUCTION CONSEQUENCES ON THE OPERATION OF NUCLEAR POWER PLANTS E. PALACIOS, J.M. ESPECHE, A. CURTI, G. MASSERA, F. SPANO. (ARGENTINA)	1073

ASQRAD: A COMPUTER CODE FOR THE QUANTIFICATION OF RADIATION DETRIMENT	1077
J.D. ROBB (UK), PJ STOKELL (UK), THIERRY SCHNEIDER (F), J.P. DEGRANGE (F). (UNITED KINGDOM, FRANCE)	
UP TO WHEN ALARA IS RELIABLE	1081
GIAN-MARIA A.A. SORDI. (BRAZIL)	
A STUDY OF THE HUMAN URINARY EXCRETION OF CHRONICALLY INGESTED URANIUM-INSIGHTS ON THE GASTROINTESTINAL ABSORPTION FACTOR	1085
MARIA LIMSON ZAMORA, J. ZIELINSKI, R. FALCOMER. (CANADA)	
EVALUATION OF INTERNAL CONTAMINATION DOSE TO EMBRYO AND FOETUS	1089
F. BREUER, L. FRITELLI. (ITALY)	
APPLICATION OF THE PROPOSED NEW ICRP LUNG MODEL TO BIOASSAY	1093
JOHN JOHNSON, ROBIN HILL, A.C. JAMES. (U.S.A.)	
A ROLE OF THE HYBRID SCALE IN RADIATION PROTECTION	1097
SHIGERU KUMAZAWA. (JAPAN)	
AN INTERIM UK RESPONSE TO REVISED RISK ESTIMATES AND ICRP 60	1101
W.P. BINES, P.F. BEAVER. (UNITED KINGDOM)	
TOWARDS UNIFORM STANDARDS OF RADIATION PROTECTION IN HEALTH CARE IN EUROPE	1105
P.P. DENDY. (UNITED KINGDOM)	
SESSION 12B	
NIR -III: HUMAN AND LABORATORY STUDIES	
RNI -III: ÉTUDES ÉPIDÉMIOLOGIQUES ET DE LABORATOIRE	
AN IN VITRO MORPHOLOGICAL INVESTIGATION ON THE SUBCELLULAR EFFECTS OF 50 HZ MAGNETIC FIELDS	1109
W. MALORNI, S. PARADISI, E. STRAFACE, M.T. SANTINI, G. DONELLI. (ITALY)	
CHAMPS ELECTRIQUES ET MAGNETIQUES ET CANCERS : EXISTE-T-IL UNE RELATION	1113
J. LAMBROZO, P. GUENEL, M. GOLDBERG, A. CHEVALIER, E. IMBERNON, B. HUTZLER, G. WARRET, W. DAB. (FRANCE)	
HEALTH EFFECTS OF ELECTRIC AND MAGNETIC FIELDS: PROGRESS AND NEW DIRECTIONS	1117
MARIA STUCHLY. (CANADA)	
HYPERSENSITIVITY TO ELECTRICITY - A WORKPLACE PHENOMENON RELATED TO LOW-FREQUENCY ELECTRIC AND MAGNETIC FIELDS	1121
BENGT KNAVE, U. BERGQVIST, R. WIBOM. (SWEDEN)	
AN APPROACH TO TACKLE VISUAL DISPLAY UNIT USER HEALTH PROBLEMS	1125
HAZEL MCCALLUM, BRIAN HEATON. (UNITED KINGDOM)	

	ETUDE DE L'EXPRESSION DES ONCOGENES DANS DES FIBROBLASTES HUMAINS APRES IRRADIATION AVEC UN LASER A IMPULSIONS TRES BREVES	1129
	DOMINIQUE DORMONT, TH. FREVILLE, H. RAOUL, D. COURANT, D. COURT. (FRANCE)	
	EVALUATION DES EFFETS CYTOGENETIQUES D'UN RAYONNEMENT LASER A IMPULSIONS TRES BREVES	1133
	GENEVIEVE GUEDENEY, D. COURANT, J.L. MALARBET, M.T. DOLLOY, M. COURT. (FRANCE)	
	A STUDY ON THE INFLUENCE OF 50-Hz MAGNETIC FIELDS ON THE CYTOTOXIC ACTIVITY OF HUMAN NATURAL KILLER CELLS	1136
	C. RAMONI, M.L. DUPUIS, P. VECCHIA, M. GRANDOLFO. (ITALY)	
	ELECTROPHYSIOLOGICAL CHANGES IN RATS AFTER MODULATED MICROWAVE IRRADIATION	1140
	L. SZABO, G. THUROCZY, G. KUBINYI, J. BAKOS. (HUNGARY)	
	IN VITRO STUDY ON THE GENOTOXICITY OF 2450 MHZ MICROWAVE IRRADIATION IN HUMAN PERIPHERAL BLOOD LYMPHOCYTES	1144
	L. VERSCHAEVE, A. MAES, A. ARROYO, C. DE WAGTER, L. MARTENS. (BELGIUM)	
SESSION 12C	EDUCATION AND TRAINING -II (PANEL)	
	ÉDUCATION ET FORMATION -II (TABLE RONDE)	
	CERTIFICATION OF HEALTH PHYSICISTS IN ASSOCIATE SOCIETIES	1148
	JILL FITCH. (AUSTRALIA)	
	RADIATION PROTECTION QUALIFICATIONS	1149
	J.R.A. LAKEY, M. WASSON. (UNITED KINGDOM)	
	LE CEFRI ET LA CERTIFICATION EN RADIOPROTECTION DES ENTREPRISES FRANCAISES	1153
	JEAN-CLAUDE MARILLIER. (FRANCE)	
SESSION 12D	OCCUPATIONAL EXPOSURE -IV: DOSIMETRY	
	EXPOSITIONS PROFESSIONNELLES -IV: DOSIMÉTRIE	
	THE ROLE OF CEDR IN WORKER HEALTH PROTECTION	1157
	BARBARA BROOKS. (U.S.A)	
	DOSIMETRIE DU PERSONNEL : SES POSSIBILITES ET SES LIMITES	1158
	G. WOLBERT, G. COUDERT, R. DOLLO, M. BERTIN. (FRANCE)	
	REFLEXIONS SUR UNE METHODE PRATIQUE D'UNIFORMISATION DE LA COMPTABILITE DES DOSES	1162
	BOUSSARD, R. DOLLO, M. DE KERVILLER, M. PENNEROUX. (FRANCE)	
P-32	PERSONNEL MONITORING IN U.S. RESEARCH INSTITUTIONS	1166
	V.N. EVDOKIMOFF. (U.S.A)	

CENTRAL INDEX OF DOSE INFORMATION (CIDI)	1168
W.J. ILES, K.A. FILLARY, E. GREENSLADE, G.M. KENDALL, T.O. MARSHALL, W.P. BINES, M. WILLIAMS. (UNITED KINGDOM)	
IMPACT OF ICRP60 ON DOSES RECEIVED BY OCCUPATIONAL EXPOSED WORKERS IN EDUCATIONAL ESTABLISHMENTS IN THE UNITED KINGDOM	1172
A.G. RICHARDS. (UNITED KINGDOM)	
CUMULATIVE RADIATION EXPOSURE AT BNFL SELLAFIELD: A HISTORICAL PERSPECTIVE	1176
K. BINKS, R. WAKEFORD, R. STRONG, D.J. COULSTON. (UNITED KINGDOM)	
DEVELOPMENT OF TLD BADGE READERS FOR PERSONNEL MONITORING IN INDIA	1180
S. KANNAN, P. RATNA, M.S. KULKARNI, T.V. VENKATESWARAN, U. MADHVANATH. (INDIA)	
NOUVELLE GESTION INFORMATIQUE DU SUIVI DOSIMETRIQUE DE L'EXPOSITION EXTERNE DES TRAVAILLEURS - APPLICATION DOSDAM	1185
YVON MAGRI, M. CHERFI. (FRANCE)	
LES TRAVAILLEURS DU GROUPE CEA: SUIVI RADIOLOGIQUE ET ANALYSES STATISTIQUES	1189
D. ROBEAU, M. TIRMARCHE, A. RAPHALEN. (FRANCE)	
SESSION 15	ICRP RECOMMENDATIONS III RECOMMANDATIONS ICRP III
RADIOLOGICAL PROTECTION IN MEDICINE - CURRENT AND PROSPECTIVE WORK OF THE ICRP	1193
JULIAN LINIECKI. (POLAND)	
FUTURE WORK OF ICRP COMMITTEE 2	1200
CHARLES MEINHOLD. (U.S.A.)	
SESSION 16A	PROTECTION CONCEPTS, POLICIES AND STANDARDS -II CONCEPTS POLITIQUES ET NORMES DE RADIOPROTECTION - II
THE DEPARTMENT OF ENERGY TIGER TEAMS: ANALYSIS OF FINDINGS AND PLANS FOR THE FUTURE	1205
P. ZIEMER. (U.S.A)	
MODELES UTILISES POUR L'ESTIMATION DES RISQUES DE RADIOCANCER: LES DIFFICULTES ACTUELLES	1210
PIERRE GALLE. (FRANCE)	
A PROPOSED FRAMEWORK FOR CONSISTENT REGULATION OF PUBLIC EXPOSURES TO RADIONUCLIDES AND OTHER CARCINOGENS	1214
DAVID C. KOCHER, F.O HOFFMAN. (U.S.A.)	
SYSTEMS TO MEASURE AIRBORNE RADIOACTIVE SUBSTANCES IN THE REACTOR CONTAINMENT IN EVENT OF A SEVERE ACCIDENT	1218
R. HOCK, H. EISGRUBER, G. KELBER. (GERMANY)	

RADIATION PROTECTION LEGISLATION IN THE NORDIC COUNTRIES	1222
LARS PERSSON. (SWEDEN)	
QUANTIFICATION OF RADIATION DETRIMENT	1226
G.A.M. WEBB, JD ROBB. (UNITED KINGDOM)	
IMPROVEMENTS IN RADIATION PROTECTION USING A PROPRIETARY AUDIT SYSTEM	1230
KEITH BOWKER, J M STEVENSON. (UNITED KINGDOM)	
OPTIMIZATION (ALARA) OF RADIATION PROTECTION AT DEPARTMENT OF ENERGY FACILITIES	1233
A.A. WEADOCK, C.R. JONES. (U.S.A.)	
ANGULAR DEPENDENCE OF ORGAN DOSES AND EFFECTIVE DOSE FOR EXTERNAL PHOTON IRRADIATION	1237
YASUHIRO YAMAGUCHI, MICHIO YOSHIZAWA. (JAPAN)	
ANALYSE COMPARATIVE DES DIFFERENTS SYSTEMES JURIDIQUES EN MATIERE DE RADIOPROTECTION	1241
MM DELPIROU. (FRANCE)	
THE REVIEW OF SAFETY CASES WITHIN BNFL	1242
J.P. SHEPHERD, A.H. FISHWICK. (UNITED KINGDOM)	
THE U.S. DEPARTMENT OF ENERGY LABORATORY ACCREDITATION PROGRAM FOR TESTING THE PERFORMANCE OF EXTREMITY DOSIMETRY SYSTEMS: A SUMMARY OF THE PROGRAM STATUS	1246
F.M. CUMMINGS, R.D CARLSON, T.F. GESELL, R.M. LOESCH. (U.S.A.)	
CRITICAL REMARKS ON THE EURATOM BASIC STANDARDS	1251
MAX HEINZELMANN, R. HILLE. (GERMANY)	
LES PROBLEMES DE L'IMPLANTATION D'UN PROGRAMME UNIVERSITAIRE DE RADIOPROTECTION	1255
JOSE CARLOS BORGES, K.C. CABALLERO. (BRAZIL)	
INTRODUCING UNIKORNES (UNITED KINGDOM OCCUPATIONAL RADIONUCLIDES EXPOSURE STUDY)	1257
J.A. WOODHOUSE. (UNITED KINGDOM)	
SESSION 16B ENVIRONMENTAL MONITORING -I: ROUTINE SURVEILLANCE SURVEILLANCE ENVIRONNEMENTALE -I: SURVEILLANCE ROUTINIERE	
THE ROLE OF RADIOACTIVITY MONITORING PROGRAMMES IN THE STUDY OF ENVIRONMENTAL PROCESSES	1258
JOHN HUNT. (UNITED KINGDOM)	
DETECTION AND DIFFERENTIATION OF CONTAMINATION THROUGH A COMPARISON OF OBSERVED LEVELS IN HISTORICAL ENVIRONMENTAL SAMPLING DATA	1262
DALE DENHAM, R. PRICE. (U.S.A)	

LE CESIUM-137 DANS LA NOIX DE COCO EN POLYNESIE FRANCAISE: CONTRIBUTION A L'EXPOSITION DE LA POPULATION	1266
CHRISTIAN POLETIKO (FP), C. ARNOULD (FP), J.P. BABLET (F), R. DUCOUSSO (F), J. SARBACH. (FRENCH POLYNESIA, FRANCE)	
RADIATION PROTECTION RELATED TO THE ENVIRONMENT OF THE FINNISH NUCLEAR POWER PLANTS	1270
ANTTI VUORINEN, OLLI VILKAMO, E. ILUS. (FINLAND)	
THE ORGANIZATION OF ENVIRONMENTAL RADIOACTIVITY CONTROL IN ITALY	1274
G. CAMPOS VENUTI, G. MONACELLI, S. PIERMATTEI, S.R. RISICA, A.F. SUSANNA. (ITALY)	
ENVIRONMENTAL RADIOLOGICAL MONITORING AROUND URANIUM MINING AND MILLING SITES IN ARGENTINA	1278
A. CURTI, A.M. BOMBEN, J.C. GOMEZ, A.A. OLIVEIRA. (ARGENTINA)	
MEASURING NETWORK FOR ENVIRONMENTAL MONITORING IN EUROPE: STATE OF THE MEASURING TECHNIQUE	1282
E. FRENZEL. (GERMANY)	
THE DETERMINATION OF RADIUM, URANIUM AND THORIUM IN LOW SPECIFIC ACTIVITY SCALES AND IN WATERS OF SOME OIL AND GAS PRODUCTION PLANTS	1286
CORRADO TESTA, D. DESIDERI, M.A. MELI, C. ROSELLI, A. BASSIGNANI, P.B. FINAZZI. (ITALY)	
OBSERVATION OF TRITIUM BY CONTINUOUS SAMPLING OF RAIN AND WATER VAPER IN OSAKA	1290
TADAO MATSUNAMI, T. ISHIYAMA, K. MEGUMI, S. KIMURA. (JAPAN)	
SURVEILLANCE DE L'ENVIRONNEMENT DE LA HAGUE	1294
S. LE BAR. (FRANCE)	
RADIOECOLOGICAL MONITORING OF THE ENVIRONMENT OF A FRENCH NUCLEAR POWER PLANT AFTER 12 YEARS IN OPERATION	1298
J. DAUMAS, L. FOULQUIER, B. DESCAMPS, S. ROUSSEL. (FRANCE)	
MONITORING OF LIQUID EFFLUENTS GENERATED AT INSTITUTO DE PESQUISAS ENERGETICAS E NUCLEARES AND ENVIRONMENTAL BEHAVIOUR OF RADIONUCLIDES IN THE ECOSYSTEM OF PINHEITOS RIVER	1302
VANUSA JACOMINO, M.F. MADUAR, G. HIROMOTO, A.M.P.L. GORDON, L. VENTURINI, A.J.G. DOS SANTOS. (BRAZIL)	
DEVELOPMENT OF GAMMA PROBE FOR RADIATION SURVEYS OF THE BOTTOMS OF SURFACE WATERS	1305
D.R. LEE, S.J. WELCH, M.J. ST. AUBIN, R. DAL BIANCO. (CANADA)	

BILAN DE LA SURVEILLANCE DE LA RADIOACTIVITE DANS L'ENVIRONNEMENT DES SITES DU COMMISSARIAT A L'ENERGIE ATOMIQUE	1308
D. ROBEAU, M. MONTJOIE, A.M. SAUVE, J. LAPORTE, A. RAHAPLEN, L. ALPHONSE, C. HUC, C. BENSIMON, G. CISSOKO. (FRANCE)	
CONTINUOUS MONITORING SYSTEM OF H-3, C-14 AND I-129-131 IN OFF-GAS FROM NUCLEAR FUEL REPROCESSING PLANT	1312
SHUZO KOJIMA, M. SHIBUYA, T. HIGASHIJIMA, M. FUJISO, T. KATO, K. SUZUKI, S. TAKIMOTO, A. TAKITA. (JAPAN)	
CLASSIFICATION OF MONITORING SITES AROUND TSURUGA NUCLEAR POWER STATION BASED ON VARIOUS VARIATIONAL PATTERNS OF AVERAGE MONTHLY EXPOSURE RATES	1316
YOSHIHIRO OGAWA, Y. KIMURA, Y. HONDA, I. URABE, T. TSUJIMOTO. (JAPAN)	
RADIOLOGICAL DOSE ASSESSMENTS IN THE NORTHERN MARSHALL ISLANDS (1989-1991)	1320
LIN-SHEN SUN, C.B. MEINHOLD, A.R. MOORTHY, J.H. CLINTON, E. KAPLAN. (U.S.A)	
DETERMINATION OF DISPERSION CONDITIONS BY USE OF WIND TUNNEL EXPERIMENTS UNDER THE PRESENCE OF DISTURBING INFLUENCES IN THE COURSE OF CALCULATIONS OF THE LOAD OF SURROUNDING AREAS	1324
P. GUGLHOR, K.H. LEHMANN, A.M. RALL. (GERMANY)	
AUTOMATIC SYSTEM FOR CONTINUOUS MONITORING OF GAMMA ACTIVITIES IN ATMOSPHERIC PARTICULATE	1327
M. MONTALTO, R. GIACOMELLI, M. NOCENTE, S. BORTOLUZZI, P. SPEZZANO. (ITALY)	
SESSION 16C	EXPOSURE TO NATURAL RADIATION -I
	EXPOSITION A LA RADIOACTIVITE NATURELLE -I
RADON EXPOSURES IN THE UK	1331
M.C. O'RIORDAN. (UNITED KINGDOM)	
LE RADON DANS L'ENVIRONNEMENT DE L'HOMME - UNE REVUE DES MESURES EFFECTUEES EN FRANCE PAR IPSN	1335
M.C. ROBE, A. RANNOU, J. LE BRONEC. (FRANCE)	
POTENTIAL RISK OF THORON AND ITS PROGENIES IN THE AIR OF TRADITIONAL JAPANESE WOODEN HOUSES	1339
MASAHIRO DOI, SADAYOSHI KOBAYASHI, KENZO FUJIMOTO. (JAPAN)	
THE LEGAL SITUATION OF RADON IN SWEDEN	1343
LARS PERSSON. (SWEDEN)	
INDOOR RADON CONCENTRATION IN SOUTH AFRICAN HOMES	1347
A. LEUSCHNER, A. STEYN, R. STRYDOM, G.P. DE BEER. (SOUTH AFRICA)	

RADIATION EXPOSURE BY MAN-MODIFIED MATERIALS CONTAINING NATURAL RADIONUCLIDES	1351
DIETRICH EKKEHARD BECKER, E. EDER, A. REICHELDT. (GERMANY)	
INDOOR RADON CONCENTRATION IN A TEST CHAMBER: EXPERIMENTAL DATA AND THEORETICAL EVALUATIONS	1355
D. CAPRA, C. SILIBELLO, G. QUEIRAZZA. (ITALY)	
RECONNAISSANCE TECHNIQUE FOR RADON RISK CLASSIFICATION OF FOUNDATION SOILS	1359
MARTIN NEZNAL, MATEJ NEZNAL, JAROSLAV SMARDA. (CZECHOSLOVAKIA)	
LE RADON DANS LES HABITATIONS - IDENTIFICATION DES SOURCES ET DES VOIES DE TRANSFERT	1363
M.C. ROBE, A RANNOU, J. LE BRONEC, G. TYMEN. (FRANCE)	
METHODOLOGIE D'EXPERTISE DE L'IMPACT RADIOLOGIQUE D'UN SITE DE DEPOT DE PRODUITS RADIFERES	1367
M.C. ROBE, A. RANNOU, V. LABED, J. LE BRONEC. (FRANCE)	
THE NATURAL RADIOACTIVITY OF NONURANIFEROUS MINES FROM ROMANIA	1371
GEORGE NICHOLAS SANDOR, G. DINCA, T. PEIO, S.D. STOICI. (ROMANIA)	
RADIOLOGICAL IMPLICATIONS OF NATURALLY OCCURRING RADIOACTIVITY IN AN ELEMENTAL PHOSPHORUS REFINERY	1375
LEO LOWE, D.B. CHAMBERS. (CANADA)	
PARAMETERS FOR CHARACTERIZATION OF RADON ABSORPTION AND DIFFUSION IN POROUS MEDIA	1379
GIORGIO CURZIO, F. D'ERRICO, A. MORI, A. GENTILLI. (ITALY)	
INTERCOMPARAISON DE L'EMANATION RADON DE PHOSPHATES DE DIFFERENTES ORIGINES (MAROC ET TUNISIE)	1383
A. KAHLIL (F), F. MEMBREY (F), D. KLEIN (F), A. CHAMBAUDET (F), R. IRAQUI (MAROC). (FRANCE, MAROC)	
MEASUREMENTS OF REGIONAL DISTRIBUTION OF Rn-222 CONCENTRATIONS AND ANALYSIS ON OPTIMAL ALLOCATION OF MONITORING STATIONS	1387
HIROKUNI YAMANISHI, YUKIMASA IKEBE, TAKAO IIDA. (JAPAN 464-01)	
INVESTIGATION ON FOOD RADIOACTIVITY AND ESTIMATION OF INTERNAL DOSE BY INGESTION IN CHINA	1391
HONGDA ZHU, JINGYUAN ZHANG, PEIZHEN HAN, X. HUANG, S. WANG. (CHINA)	
DETERMINATION OF THE FACTORS THAT CONTROL MIGRATION AND ENTRY OF RADON INTO BASEMENTS	1395
THOMAS B. BORAK. (U.S.A)	

**SESSION 16D DECONTAMINATION AND DECOMMISSIONING
 DÉCONTAMINATION ET DÉMANTELEMENT D'INSTALLATIONS
 NUCLÉAIRES**

RADIOLOGICAL OPTIMIZATION IN A REACTOR DISMANTLING PROGRAMME	1396
TH. ZEEVAERT, PAUL GOVAERTS, P. CROUAIL. (BELGIUM)	
DEMANTELEMENT DE CHINON A2	1404
M. CAMPANI, M. BETSCH, F. MUNOZ. (FRANCE)	
RADIOLOGICAL HAZARDS FROM DEPOSITS OF TIN-SMELTING SLAG AND THE PROBLEMS OF SITE CLEARANCE AND DISPOSAL	1408
J.C. GILMORE, R.G JACKSON. (ENGLAND)	
RADIATION CONTROL EXPERIENCE DURING JPDR DECOMMISSIONING	1412
JUNICHI ONODERA, C. NAKAMURA, H. YABUTA, Y. YOKOSUKA, T. NISIZONO, Y. IKEZAWA. (JAPAN)	
LA REGLEMENTATION FRANCAISE EN MATIERE DE LIMITATION DES RISQUES RADIOLOGIQUES DES SITES MINIERS URANIFERES	1416
J. PRADEL, P. ZETTWOOG. (FRANCE)	
TRAITEMENT PAR FUSION DES DECHETS METALLIQUES FAIBLEMENT CONTAMINES PAR DES SUBSTANCES RADIOACTIVES	1420
C. ANDRIEUX, C. DOUCET, J.C. LEBRUN. (FRANCE)	
UTILISATION D'UN MELANGE TRIPHASIQUE PRESSURISE GRAPHITE-EAU-OXYGENE INCINERATION DIRECTE DE GRAPHITE IRRADIE	1424
GERARD ANTONINI, JP PEROTIN, P. CHARLOT. (FRANCE)	
TRAITEMENT DES ACIERS CONTAMINES EN PROVENANCE DES REACTEURS UNGG G2 ET G3 EN VUE D'UNE REUTILISATION DANS LE DOMAINE INDUSTRIEL	1428
JEAN DECITRE. (FRANCE)	
ETUDE D'UNE SYSTEME DE MICROPRELEVEMENTS SURFACIQUES PAR IMPACT LASER POUR L'ANALYSE ULTERIEURE DE SURFACES CONTAMINEES	1432
J.J. GAUMET, F. MEMBREY, A. CHAMBAUDET, G. MADELAINE, D. BOULAUD, P. ZETTWOOG. (FRANCE)	
GUIDE FOR DECONTAMINATION IN P.W.R. POWER PLANTS	1436
Y. HERISSON, C. GLORENNEC. (FRANCE)	
DECOMMISSIONING OF NUCLEAR FACILITIES IN GERMANY - RADIATION EXPOSURE CAUSED BY THE UNHARMFUL REUSE OF RADIOACTIVE RESIDUAL MATERIALS	1440
PETER GUGHLOR, K.H. LEHMANN, B. JAHNERT. (GERMANY)	
VALDEC-F PROJECT FOR THE TREATMENT OF LOW ACTIVITY SCRAP STEEL	1443
HENRI GODARD. (FRANCE)	

FRENCH EXPERIENCE WITH ELECTROPOLISHING	1447
P. SAURIN, C. WEBER, N. ENGLER, B. LANTES, A. BRISSAUD, P. RIDOUX, P. BESLU, S. ANTHONI, J.P CIZEL. (FRANCE)	
DEMANTELEMENT DE L'INSTALLATION DE RETRAITEMENT AT.1 DE LA HAGUE	1451
CLAUDE LAFFAILLE. (FRANCE)	
DECONTAMINATION PROCESSES APPLIED DURING DA 1 S.G. REPLACEMENT	1455
Y.M. BEISSIERE, B. LANTES, P. SAURIN, C. BRUN, P. BESLU. (FRANCE)	
SESSION 17A	INTERNATIONAL ORGANIZATIONS ORGANISATIONS INTERNATIONALES
LA NORMALISATION INTERNATIONALE UN OUTIL POUR LA RADIOPROTECTION	1459
L. FITOUSSI. (FRANCE)	
THE PROGRAMME OF THE IAEA IN RADIOLOGICAL PROTECTION	1463
ABEL J. GONZALEZ. (IAEA)	
THE ROLE OF THE IAEA ON THE CONTROL AND SAFE USE OF RADIATION SOURCES	1464
J.U. AHMED. (IAEA)	
THE CONTRIBUTION OF THE OECD NUCLEAR ENERGY AGENCY IN RADIOLOGICAL PROTECTION.	1468
OSVALDO ILARI. (NEA)	
THE RESEARCH PROGRAMME OF THE COMMISSION OF THE EUROPEAN COMMUNITIES IN RADIOLOGICAL PROTECTION.	1469
J. SINNAEVE. (CEC)	
U.I.R.: ORGANISATION ET PROGRAMME	1470
C. MYTTENAERE. (BELGIQUE)	
SESSION 18A	OPTIMISATION IN RADIATION PROTECTION -I OPTIMISATION EN RADIOPROTECTION -I
OPTIMISATION OF RADIOLOGICAL PROTECTION IN COMPLEX SITUATIONS	1474
FRANK PHILLIPS, R.W. ALLOTT, H.L. WILKINSON. (UNITED KINGDOM)	
DECISION-MAKING UNDER RISK IN THE OPTIMIZATION OF RADIOLOGICAL PROTECTION APPLIED TO DESIGN	1477
DANIEL HERNANDEZ. (ARGENTINA)	
PRATIQUE DE L'OPTIMISATION DE LA RADIOPROTECTION SUR LE CENTRE DE RETRAITEMENT DES COMBUSTIBLES IRRADIES DE LA HAGUE DEPUIS 1976	1481
JACQUES BETIS. (FRANCE)	
OPTIMISATION DE LA RADIOPROTECTION DANS L'OPERATION DE CHANGEMENT DE BROCHES DES TUBES GUIDE DE GRAPPES D'UNE CENTRALE A EAU PRESSURISEE	1485
B. BLAIN, B. BREGEON, P. SAUMON. (FRANCE)	

LA POLITIQUE D'OPTIMISATION DE LA RADIOPROTECTION A ELECTRICITE DE FRANCE LUCIEN BERTRON, LAURENT STRICKER. (FRANCE)	1489
A PRACTICAL METHOD FOR THE APPLICATION OF ALARA PRINCIPLE IN FACILITY DESIGN ROGER JACKSON. (ENGLAND)	1493
BILAN DOSIMETRIQUE DES DECENNALES DES UNITES 2 - 4 ET 5 REALISEES EN 1990-1991 AU CENTRE NUCLEAIRE DU BUGEY JEAN FLUCHERE. (FRANCE)	
UN CAS D'OPTIMISATION DE LA RADIOPROTECTION LE PREMIER RGV FRANCAIS: DAMPIERRE 1990 R. HOCHART, O. JURION. (FRANCE)	1500
CONTAMINATION ASPECT FOR THE STEAM GENERATOR REPLACEMENT S. ANTHONI, P. RIDOUX, J.L. TROMBINI. (FRANCE)	1504
OCCUPATIONAL EXPOSURE TREND AND THE RADIOLOGICAL PROTECTION OPTIMIZATION CRITERIA IN SPANISH NUCLEAR POWER PLANTS IN OPERATION: PRESENT AND FUTURE P. O'DONNELL.	1508
SESSION 18B ENVIRONMENTAL MONITORING -II: POST ACCIDENT SURVEILLANCE ENVIRONNEMENTALE -II: AUTRES ACCIDENTS	
LE PROGRAMME RESSAC: BILAN ET PERSPECTIVES HENRI MAUBERT, P. FACHE, A. JOUVE, P. RONGIER, E SCHULTE. (FRANCE)	1512
ON THE STATISTICAL MEANING OF ENVIRONMENTAL MODELS USED IN DERIVING INTERVENTION REFERENCE LEVELS F. BREUER, LUIGI FRITTELLI, A. ROGANI. (ITALY)	1516
U.S. RECOMMENDATIONS FOR CONTROL OF ACCIDENTAL RADIOACTIVE CONTAMINATION OF HUMAN FOOD AND ANIMAL FEEDS BRUCE M. BURNETT, M. ROSENSTEIN. (U.S.A.)	1520
MEASUREMENT, ASSESSMENT AND EVALUATION WITHIN THE INTEGRATED MEASUREMENT AND INFORMATION SYSTEM FOR SURVEILLANCE OF THE RADIOACTIVITY ANTON BAYER, D. NOBKE, J. BURKHARDT, A. LOBKE-REINL, M. WERNER, H. LEEB, K. JUNG, C. WITTLER, J. LIESER, W. WEISS. (GERMANY)	1524
LA MISSION ET LES MOYENS DU SCPRI, SERVICE OFFICIEL FRANCAIS DE RADIOPROTECTION, EN CAS D'ACCIDENT NUCLEAIRE PIERRE PELLERIN, JEAN CHANTEUR, JEAN-PIERRE MORONI. (FRANCE)	1528

CARTOGRAPHIE PAR HELICOPTERE DES DEPOTS RADIOACTIFS AU SOL EN SITUATION ACCIDENTELLE JACQUES CORTELLA, C. BOURGEOIS, R. CHASTEL, A. ROSENBERG. (FRANCE)	1529
CONCENTRATION OF STABLE CESIUM IN CALF SERUM NOBUHIKO ITO. (JAPAN)	1533
MEASUREMENT IN THE FIELD OF THE CONCENTRATION OF GAMMA EMITTERS NUCLIDES IN SOIL SANDRO BORTOLUZZI, ROBERTO GIACOMELLI, MARIO MONTALTO, MAURO NOCENTE, PASQUALE SPEZZANO. (ITALY)	1537
RESULTS OF THE ENEA INTERCOMPARISON CAMPAIGNS FOR THE RADIOACTIVITY SURVEILLANCE NETWORK IN ITALY P. DE FELICE, R.F. LAITANO, S. PIERMATTEI, PONA C.. (ITALY)	1541
POST-CHERNOBYL FALLOUT IOLANDA OSWATH, C. DOVLETE. (ROMANIA)	1545
SESSION 18C EXPOSURE TO NATURAL RADIATION -II EXPOSITION A LA RADIOACTIVITÉ NATURELLE -II	
RADON IN THE HUMAN ENVIRONMENT - A GLOBAL APPROACH F. STEINHAUSLER. (AUSTRIA)	1549
RADON-INDUCED LUNG CANCER RISK AT ENVIRONMENTAL DOSE LEVELS WERNER HOFMANN, D.J. CRAWFORD-BROWN. (AUSTRIA)	1553
EXPOSURE TO COSMIC RADIATION: A DEVELOPING MAJOR PROBLEM IN RADIATION PROTECTION JOHN WILSON, FERENC HAJNAL. (U.S.A)	1557
EXPOSURE TO RADON IN ABOVE GROUND WORKPLACES - THE EXPERIENCE IN GREAT BRITAIN (GB) BRIAN ROSS, D.W. DIXON. (GREAT BRITAIN)	1558
NATURAL RADIATION INDOOR EXPOSURE OF ITALIAN POPULATION F. BOCHICCHIO, G. CAMPOS VENUTI, S. MANCIOPPI, S. PIERMATTEI, S. RISICA, L. TOMMASINO, G. TORRY. (ITALY)	1561
RADON IN THE OFFICE ENVIRONMENT D. AZIMI-GARAKANI. (SWITZERLAND)	1566
ETUDE EXPERIMENTALE DES EFFETS GENETIQUES DE LA RADIOACTIVITE NATURELLE MARCEL DELPOUX, H. DULIEU, A. LEONARD. (FRANCE)	1570
TEMPORAL VARIATIONS OF INDOOR RADON CONCENTRATIONS BENNY MAJBORN. (DENMARK)	1574
RADON EXHALATION RATES FROM BUILDING MATERIALS AND FLY ASH-CONTAINING CONCRETES A. BATTAGLIA, D. CAPRA, G. QUEIRAZZA, A. SAMPAOLO. (ITALY)	1578

RADON SURVEY IN METROPOLITAN TORONTO SCHOOLS ERNEST BECKER, REZA MORIDI. (CANADA)	1582
RECONSTRUCTION OF THE RADON DAUGHTER EXPOSURE OF BEAVERLODGE URANIUM WORKERS D.B. CHAMBERS, R.H. STAGER, F.D. BERNARD, L.M. LOWE. (CANADA)	1586
MATHEMATICAL MODEL FOR CALCULATION OF THE LUNG DOSE FROM INHALED RADON-222 AND ITS DAUGHTERS DRAGOSLAV NIKEZIC, PETAR MARKOVIC. (YUGOSLAVIA)	1590
CALIBRATIONAL AND EXPERIMENTAL DETERMINATION OF THE CALIBRATION COEFFICIENT FOR RADON MEASUREMENTS USING LR-115 DETECTOR IN A DIFFUSION CHAMBER PETAR MARKOVIC, DRAGOSLAV NIKEZIC. (YUGOSLAVIA)	1594
FACTORS AFFECTING RADON LEVELS IN HOMES IN BRITISH COLUMBIA, CANADA D.R. MORLEY, B.G. PHILLIPS, C. VAN NETTEN. (CANADA)	1598
MEASUREMENT OF RADON ACTIVITY AT SOME RADIOACTIVE SITES IN INDIA J. SINGH, L. SINGH, S. SINGH, H.S. VIRK. (INDIA)	1603
DETECTION OF RADON AND RADON DAUGHTERS BY MEANS OF AN ELECTRET IONIZATION CHAMBER COMBINED WITH SOLID STATE NUCLEAR TRACK DETECTORS BIRGIT DORSCHER, B. BURGHARDT, S. KUNZMANN, J. LEWITZ, E. PIESCH, H. SEIFERT, G. STREUBEL. (GERMANY)	1607
MEASUREMENTS OF RADON CONCENTRATIONS IN BUILDINGS - RESULTS OF INVESTIGATIONS IN MINING REGIONS OF SAXONY AND THURINGIA R. CZARWINSKI, R. LEHMANN, W. ROHNSCH. (GERMANY)	1611
CLEANERS IN REDUCING THE HAZARDS OF INDOOR RADON DECAY PRODUCTS N.. MONTASSIER, P.K. HOPKE, Y. SHI, P. WASIOLEK, B. MCCALUM. (U.S.A)	1616
HIGH-ALTITUDE COSMIC RAY NEUTRONS: SIGNIFICANT CONTRIBUTOR TO THE RADIATION EXPOSURES AT AIRCRAFT ALTITUDES FERENC HAJNAL, JOHN J. WILSON. (USA)	1620
RADON IN SHOW CAVES, VISITOR MINES, AND SPAS OF NORTH RHINE-WESTPHALIA A. ROX, W. HERZOG. (GERMANY)	1621
INDOOR GAMMA CONTRIBUTION TO NATURAL RADIATION EXPOSURE IN ITALY GLORIA CAMPOS VENUTI, L. LEMBO, S. PIERMATTEI, G. SCARPA. (ITALY)	1625

LUNG DOSE MODELLING FROM REALISTIC MEASUREMENTS OF
OCCUPANCY EXPOSURE TO RADON PROGENY 1629
ANDREW SINGMIN. (CANADA)

SESSION 18D TRANSPORT OF RADIOACTIVE MATERIALS
TRANSPORT DES SUBSTANCES RADIOACTIVES

PRESENTATION DES PRINCIPALES LECONS TIREES PAR LES PAYS
MEMBRES DE LA COMMUNAUTE EUROPEENNE SUITE D'ACCIDENTS OU
D'INCIDENTS DE TRANSPORT DE MATIERES RADIOACTIVES 1633
JACQUES LOMBARD (F), C. RINGOT (F), K.B. SHAW (UK), J.S.
HUGHES (UK). (FRANCE, UNITED KINGDOM)

A TRANSPORT ACCIDENT AND INCIDENT DATABASE 1637
BRIAN ROSS, K. B. SHAW, J. S. HUGHES, C. K. WILSON.
(UNITED KINGDOM)

REFLEXION SUR L'IMPACT DES NOUVELLES RECOMMANDATIONS DE
LA CIPR SUR LA REGLEMENTATION DES TRANSPORTS 1641
JEAN HAMARD, CLAUDE RINGOT, G. BENISTAN, A. LAUMOND.
(FRANCE)

RADIATION DOSES FROM THE TRANSPORT OF RADIOACTIVE
MATERIAL IN THE UNITED KINGDOM 1646
CHRISTOPHER WILSON, K.B SHAW. (UNITED KINGDOM)

STATUS OF SHIELDING ANALYSIS METHODS FOR TRANSPORT
PACKAGES 1650
C.V. PARKS, B.L. BROADHEAD, M.C. BRADY. (U.S.A)

DEVELOPMENT OF EXPERT SYSTEM FOR TRANSPORT OF RADIOACTIVE
MATERIALS 1654
YUKIHIRO SHIGETA, YOSHITAKA KIMURA, HAJIMA YABUTA,
KEISUKE HASEGAWA, YOSHIO IKEZAWA. (JAPAN)

SESSION 19A OPTIMISATION IN RADIATION PROTECTION -II
OPTIMISATION EN RADIOPROTECTION -II

SECURITE ET MANAGEMENT 1658
ALAIN MOREAU. (FRANCE)

STANDARDIZED RADIOLOGICAL HAZARD ANALYSIS FOR A BROAD
BASED OPERATIONAL RADIATION SAFETY PROGRAM 1662
W. WADMAN III, L. ANDREWS. (U.S.A.)

L'OPTIMISATION DE LA RADIOPROTECTION SUR LE SITE DE
MARCOULE 1666
A CLECH, A. DEVITA. (FRANCE)

REMOTE OPERATIONS AND ROBOTS IN NUCLEAR POWER PLANTS--OUT
LOOK AND REALITIES 1670
P. JEZEQUEL. (FRANCE)

VENTILEX UN SYSTEME EXPERT EN VENTILATION NUCLEAIRE 1674
CLAUDE ROUSSEL, DOMINIQUE SOULATGES. (FRANCE)

PANTHERE RP: A TOOL FOR PREVISION OF DOSE RATES 1677
PH. RIDOUX, A. BRISSAUD. (FRANCE)

- ON THE SURVEY AND EVALUATION OF RESEARCH SUPPORTED BY
THE SWEDISH RADIATION PROTECTION INSTITUTE 1681
LARS PERSSON, LEIF MOBERG. (SWEDEN)
- DOSIANA: SOFTWARE PACKAGE FOR OPERATIONAL DOSE MANAGEMENT
IN NUCLEAR INSTALLATIONS 1685
CHRISTIAN LEFAURE, G. TARALL, B. BREGEON. (FRANCE)
- SESSION 19B ENVIRONMENTAL MONITORING -III: CHERNOBYL
SURVEILLANCE ENVIRONNEMENTALE -III: TCHERNOBYL
- COMPORTEMENT DU RADIOCESIUM EN ECOSYSTEME FORESTIER
CONTAMINE LORS D'UN ACCIDENT NUCLEAIRE 1689
YVES THIRY, C. RONNEAU, C. MYTTENAERE. (BELGIQUE)
- TRANSPORT OF CHERNOBYL RADIONUCLIDES IN FRESHWATER
LAKES 1693
GERHARD LINDNER, I. GREINER, R. GROM, S. KAMINSKI, J.
KLEINER, A. KULIKOV, W. PFEIFFER, J.A. ROBBINS, O.
SEEWALD. (GERMANY)
- RADIOCESIUM BODY BURDENS IN NORTHERN CANADIANS 1697
B.L. TRACY, H. KRAMER. (CANADA)
- STUDIES ON IN-SITU MEASUREMENT OF FALLOUT NUCLIDES
DERIVED FROM THE CHERNOBYL REACTOR ACCIDENT USING HIGH
PURITY GERMANIUM DETECTOR 1701
KUNIO TERAJ, K. FUJII, M. NAKAZAWA, T. HAMADA, K. KOMURA.
(JAPAN)
- COMPARISON OF MEASURED RADIOECOLOGICAL PARAMETERS IN
AACHEN AFTER THE CHERNOBYL ACCIDENT WITH VALUES USED IN
THE FEDERAL REPUBLIC OF GERMANY 1705
HANS BONKA. (GERMANY)
- MECHANISMS OF CESIUM TRANSFER IN FOREST ECOSYSTEMS
OBTAINED FROM CONTINUOUS MONITORING OF ROEDEER
CONTAMINATION 1709
GREGOR ZIBOLD, J. DRISSNER, W. ERB, T. HERRMANN, M. HUND,
G. LINDNER, C. WILHELM, J. WOLF. (GERMANY)
- SUIVI DE LA CONTAMINATION EN CESIUM 137 DE CHAMPIGNONS
DANS UNE REGION FRANCAISE APRES L'ACCIDENT DE
TCHERNOBYL 1713
N. BROQUET, A. CHAMBAUDET, J.P. CHAUMONT, D. KLEIN, J.
SIMERAY. (FRANCE)
- THE SHORT LIFE RADIONUCLIDES IN MEAT AFTER THE NUCLEAR
ACCIDENT IN CHERNOBYL 1717
M. SMELCEROVIC, D. POPOVIC, G. DJURIC. (YUGOSLAVIA)
- ENVIRONMENTAL RADIONUCLIDE MIGRATION IN THE BIWA-LAKE AT
THE CENTRAL PART OF JAPAN 1721
HIROSHIGE MORISHIMA, TAEKO KOGA, TAKEO NIWA, HIROSHI
KAWAI, SOHEI KONDO, YASUSHI NISHIWAKI. (JAPAN)

AIR TO MILK TRANSFER OF CESIUM-137 C. PAPASTEFANOU. (GREECE)	1725
THE SPANISH ENVIRONMENTAL SURVEILLANCE RADIOLOGICAL NETWORK (REVIRA) J.L. BUTRAGUENO, J.P. GARCIA, M.J. GRANADA. (SPAIN)	1729
PROGRESS ON THE IAEA-CEC PROGRAMME ON VALIDATION OF ENVIRONMENTAL MODEL PREDICTIONS (VAMP) G.S. LINSLEY, S. HOSSAIN, M.J. CRICK, K.L. SJOEBLOM, G.N. KELLY. (AUSTRIA)	1733
SESSION 19C MEDICAL SURVEILLANCE OF RADIATION WORKERS SURVEILLANCE MÉDICALE DES TRAVAILLEURS EXPOSÉS AUX RAYONNEMENTS	
DIAGNOSIS OF THYROID NODULES AND MEDICAL FITNESS FOR RADIATION WORK: CASE CONTRIBUTIONS ERNESTO STRAMBI, M. VIRGILI. (ITALY)	1773
USE OF MICRONUCLEI IN BIOLOGICAL DOSIMETRY WITH GAMMA-RAYS: A METHOD FOR RAPID SCREENING IN THE CASE OF LARGE-SCALE RADIATION ACCIDENTS M. DI GIORGIO, M. FERRARO, E. THOMASZ. (ARGENTINA)	1734
MEDICAL ASPECTS OF RADIATION PROTECTION IN NORMAL AND ACCIDENTAL SITUATION DRAGOSLAV STOJANOVIC. (YUGOSLAVIA)	1738
CYTOGENETIC MONITORING OF NUCLEAR POWER PLANT WORKERS IN FINLAND SISKO SALOMAA, A. KOIVISTOINEN. (FINLAND)	1742
CHROMOSOMAL ABERRATIONS IN PERSONS PROFESSIONALLY EXPOSED TO IONISING RADIATION GORDANA JOKSIC, B. MARKOVIC. (YUGOSLAVIA)	1746
PRELIMINARY REPORT OF A FETAL-THYROID OVEREXPOSURE CASE DUE TO THE ADMINISTRATION OF I-131 DURING THE SECOND TRIMESTER OF PREGNANCY J.C. GIMENEZ, G. ALCARAZ, S. GUTIERREZ. (ARGENTINA)	1750
GUIDELINE VALUES FOR SKIN DECONTAMINATION MEASURES BASED ON NUCLIDSPECIFIC DOSE EQUIVALENT RATE FACTORS HELMUT PFOB, GUNTER HEINEMANN. (GERMANY)	1754
CYTOCHEMICAL INVESTIGATION METHODS AS A CONTRIBUTION DIAGNOSTING LEUKOCYTE TRITIUM DAMAGE SNEZANA MILACIC, S. DODIC, V. NIKOLIC. (YUGOSLAVIA)	1758
CLINICAL CRITERIONS FOR BIODOSIMETRY AT WORKERS EXPOSED TO LOW DOSES OF IONIZING RADIATIONS VERA NIKOLIC, G. JOKSIC, S. MILICIC. (YUGOSLAVIA)	1762
A CASE STUDY OF AN ACCIDENTAL INHALATION OF AM-241 FROM A RUPTURED SOURCE JAN KRUGER, P.J. KRUGER, D BOUWER, J. ALBASINI. (REPUBLIC OF SOUTH AFRICA)	1765

MONITORING OF URINE BY EXTRACTION CHROMATOGRAPHY WITH
TRI-N-OCTYLPHOSPHINE OXIDE SUPPORTED ON A POLYPROPYLENE
COLUMN 1769
N. BONINO, J. DIODATI, M. CENA. (ARGENTINA)

SESSION 19D RADIOACTIVE WASTE MANAGEMENT AND DISPOSAL
ÉLIMINATION DES DÉCHETS RADIOACTIFS

THE DEVELOPMENT OF NRPB ADVICE FOR THE DISPOSAL OF SOLID
RADIOACTIVE WASTE 1777
J.R. COOPER, I.M. BARRACLOUGH, S.F. MOBBS. (UNITED
KINGDOM)

LONG-TERM UNCERTAINTY IN RADIOLOGICAL PERFORMANCE
ASSESSMENTS OF LOW-LEVEL WASTE FACILITIES AT THE SAVANNAH
RIVER SITE 1781
LAURA MCDOWELL-BOYER. (U.S.A.)

ORGANISATION GENERALE D'EDF POUR LE CONDITIONNEMENT ET
L'ENTREPOSAGE DES DECHETS DE FAIBLE ET MOYENNE
ACTIVITE 1785
Y. FITAMANT. (FRANCE)

POLITIQUE DE GESTION DES MATIERES DE TRES FAIBLE
RADIOACTIVITE 1789
A.M. CHAPUIS, Ph. GUETAT. (FRANCE)

RADIOACTIVE WASTE STORAGE AND DISPOSAL: A THEORETICAL
STUDY 1793
GURINDER SINGH. (INDIA)

OPTIMISATION DU PRINCIPE ALARA EN MATIERE DE GESTION ET
D'ELIMINATION DE DECHETS RADIOACTIFS DE TRES FAIBLE
ACTIVITE 1794
A. REGIBEAU, J. CAUSSIN, M. DE SPIEGELEER, M. POELAERT.
(BELGIQUE)

COMMENT ELECTRICITE DE FRANCE A DIVISE PAR 2 EN 5 ANS LE
VOLUME ANNUEL DE DECHETS RADIOACTIFS PRODUITS DANS SES
CENTRALES 1798
J. HERISSON. (FRANCE)

ASPECTS DE MINIMIS EXEMPLE DE DIFFICULTES RECENTES
RECONTREES DANS LES CENTRALES NUCLEAIRES D'EDF POUR LA
GESTION DES DECHETS TRES FAIBLEMENT RADIOACTIFS. 1802
PIERRE BOUSSARD, JEAN-MARC DUCOULOMBIER. (FRANCE)

MOYENS INFORMATIQUES MIS EN OEUVRE A EDF POUR GERER
RATIONNELLEMENT LES DECHETS RADIOACTIFS 1806
M. COMMUNAUX, J. HERISSON. (FRANCE)

PROBLEMES POSES PAR LA COLLECTE ET LA PRISE EN CHARGE DU
RADIUM 1810
PHILIPPE KISSEL, PATRICE CHARBONNEAU. (FRANCE)

THE MIGRATION OF CESIUM-137 THROUGH THREE DIFFERENT
FORMULATIONS OF COMPRESSIVELY STRESSED GROUT 1814
RICHARD R. BREY, ROBERT R. LANDOLT. (U.S.A)

PROBABILISTIC APPROACH TO NDA FOR NON-UNIFORM
RADWASTES 1818
MYUNG CHAN LEE, DUCK J. KOH, SEUNG RO, HEE SHIN. (KOREA)

ON THE REDUCTION OF Rn-222 EXHALATION FROM Ra-226-RICH
WASTES BY COVERING OF SOIL 1824
YUKIMASA IKEBE. (JAPAN)

THE DEVELOPMENT OF INTERNATIONALLY ACCEPTED EXEMPT LEVELS
OF RADIONUCLIDES IN SOLID MATERIALS 1828
G.S. LINSLEY. (AUSTRIA)

SESSION 20

COMPARISON BETWEEN RADIOLOGICAL PROTECTION AGAINST
IONIZING RADIATION AND NON IONIZING RADIATION 1829
H. JAMMET. (FRANCE)

LATE PAPERS

RULES AND REGULATIONS ON RADIATION PROTECTION IN PERU 1840
E. MEDINA-GIRONZINI. (PERU)

IRPA8

**Association internationale
de radioprotection**

**International Radiation
Protection Association**



ACTES DU CONGRÈS / PROCEEDINGS

Volume I

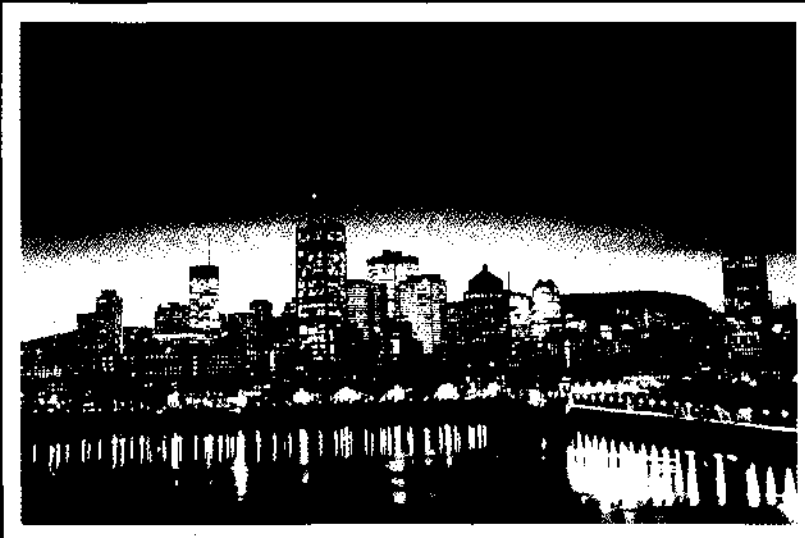

MONTREAL 92-05-17 AU/TO 92-05-22

PALAIS DES CONGRÈS

1992 SIEVERT LECTURE

ETHICAL ISSUES

IN

RADIATION PROTECTION

Giovanni Silini
Via S. Maurizio, 22 24065 LOVERE (Bergamo) Italy

PREFACE

Contrary to those who preceded me in this series of lectures, I never knew Professor Rolf M. Sievert because when he died in 1966 I was just starting my work in animal radiation biology and only later did I become acquainted with the subject and problems of radiation protection. However, judging from what I have come to know about Sievert through his work and conversations with friends who were associated with him, this large congress of people would not have been possible without his pioneering work. In him, scientific excellence was paralleled by penetrating intuition. In a 1947 lecture in honour of Sylvanus Thompson, commenting on the fact that a new epoch, that of atomic energy, was about to come, he had the following to say: "We cannot as yet estimate what risks of injury by radiation this epoch can bring. We have, however, reason to expect that the problem of protection against injuries by ionizing radiation will be of an entirely other magnitude than hitherto, and it is probable that it will become a general social problem of prime importance". Clearly, a remarkable foresight about a discipline that has gradually flourished internationally to its present state.

The honour that IRPA has bestowed upon me by asking to deliver this lecture is in sharp contrast with the little I have achieved in radiation protection. Others, with better credentials and authority, might have done a better job. But since this burden has fallen upon me, I can only hope that what I am about to say will not be too unworthy of the person we remember and of those who paid tribute to his memory in past lectures.

INTRODUCTION

My intention today is not that of delivering a sermon. It is simply to bring you to consider some of the ideas that underlie the principles and the numbers that we are confronted with every day in our professional life. It is to discuss the fundamental values that are implicit in our practical activities, and to verify that we have not lost touch with the principles of human respect and compassion that must inspire our work as members of a scientific community.

Radiation protection is not a fundamental science, a free intellectual re-construction of the why's and how's of nature, that may be regarded as intrinsically good, in so far as it only tends to enlarge the boundaries of human knowledge. Radiation protection is an applied discipline. Its purpose is to define the limits within which some human activities with potentially harmful consequences may safely be carried out. This requires discussion of the principles on which protection of the individuals and of the species should be based, and necessarily involves ethical considerations.

As some of you may know, ethical principles are of two kinds: there are the very general first-order ones, that is the values that should ultimately guide all choices for any action; and the more limited second-order principles, dealing mainly with the meaning and the applicability of the ethical language and the analysis of ethical concepts (Mackie 1977). Of the first set of principles, only one, perhaps, is required by radiation protection: the principle that to improve health and living conditions and thus to minimize the suffering of human beings is a good aim in itself, and therefore an objective that we ought to work for.

It is characteristic of ethical principles to be universalized, in the sense that when a principle is seen as ethically right, those who adopt the principle are committed to follow it under all relevant circumstances, irrespective of any qualitative differences of those stating, or affected by, the principle in question. A further stage in this process of universalization is to apply the principle irrespective of how individuals might vary in respect to their physical and mental qualities, resources or social status, including those individuals who will only be born in the future (Mackie 1977). Usually, radiation protection does not demand adoption of a third and more advanced stage of universalization, that of applying a principle irrespective of preferences, tastes, values or ideas.

So, except for one very general first-order principle, radiation protection does not require any other major ethical statement. In this context, therefore, morality is understood in the restricted sense of a methodology to set special constraints of conduct in the interest of those exposed to radiation to develop guidelines to restrain the selfish inclination by some agent or agents to act against such interest. This more limited function is however important in promoting the development of universally acceptable ethical behaviours.

Since radiation protection principles are meant to apply to all persons and societies, they should be sufficiently flexible to be adopted in countries with a wide spectrum of religious, political, social and economic conditions. They should also be sufficiently comprehensive to apply reasonably to all activities involving radiation exposure, even those for which exposure has a low

probability of occurrence. Finally, they should cover both present and foreseeable exposure situations.

Owing to all these requirements, it is obvious that such principles could not be derived from sets of values belonging to the cultural heritage of any particular group, but should be built on universally-shared secular values. These are, for example, the equality of rights for all human beings; the need to reasonably balance the interests of any individual against those of all others; the requirement to protect our species by preserving the material conditions for its continuation; and, finally, the right for each person to try to achieve freedom from one common heritage of the human condition, which is suffering and sorrow.

The main question I should like to discuss is: to what extent do we cover all these requirements in our particular field?

Present radiation protection doctrine (ICRP 1990) is based on a body of scientific knowledge, one underlying assumption and three general principles. My objective is to discuss first the adequacy of the existing scientific information for the purpose of setting safety standards; then to consider the foundation of the underlying assumption; and finally, to discuss a few aspects of the three general principles. All this, of course, in the light of ethical considerations.

THE BASIC SCIENTIFIC DATA

Let me start with the scientific bases on which the system is built (Silini 1991). As you all know, we classify radiation effects into a few major groups, according to their nature and mode of expression at different dose levels. For some effects, our knowledge derives from direct experience in man, gained in many cases in an attempt to cure disease; sometimes as a result of accidents in the course of industrial activities; and in a few cases as a consequence of deliberate acts of warfare or the development of weapons.

Broadly speaking, we identify at high dose deterministic effects on cells, tissues or the whole body. These may be clinically dramatic, but are usually not too difficult to avoid, except in the course of accidents. Experience of these effects in man is large. Therefore, their prediction as a function of dose, time and radiation quality is rather well founded (UNSCEAR 1982, 1988).

At low or very low doses and dose rates effects of a different nature are seen. They are called late somatic (or stochastic) and consist in the appearance of an excess of cancer and leukaemia above the natural rate. Their existence is proven, but precise assessment of their rate of induction per unit dose is difficult in man. To this end, primary data obtained from human epidemiology must be adapted for general use to account for various dependencies on dose, dose rate, organs, age, time of induction and other variables of radiobiological interest. Recently, our understanding of all these risk-related variables has considerably increased. As a result, one feels that current estimates are more realistic than in the past and, perhaps, less likely to increase further, barring drastic changes in the projected trend of the primary data or new and unexpected findings. Of course, our knowledge of these effects is only descriptive. We still lack the understanding of the mechanisms through which cancer (and radiation-induced cancer in

particular) is brought about.

For both classes of somatic effects - the deterministic and the stochastic - there is enough experience in man, so that models of induction in animals may simply be used to fill the gaps and to generalize dose-time relationships and trends with radiation quality. This is good, because the species-specificity of many of these effects is so pronounced that it would simply be impossible to project rates of induction across species. It is acceptable, however, to use animal data in order to project general trends with dose and time or to validate mechanisms.

Unfortunately, for a third class of effects, the stochastic hereditary ones, we are still to a large extent dependent on data from experimental animals. The existence of clinically relevant hereditary effects brought about by alteration of germinal cells in man has never been demonstrated, but the absence of such evidence is not in itself a cause for reassurance nor concern. Since radiation may definitely cause such effects in many other living species and we know of no special reason why the human genome should be an exception, we must assume that the human species may also be susceptible. The best we can do, under these circumstances, is to take the estimates of hereditary effects in species that are phylogenetically near to man and try to adapt these estimates for our species, on the basis of present knowledge of human genetics. Scientifically this procedure is unsatisfactory. Ethically it is justified out of necessity, as the only possible course of action.

An important ethical issue deals with the assessment of those hereditary effects that may appear in man in the very far future. A significant step forward - at variance with previous (ICRP 1977) practice - has been taken recently by ascribing all genetic damage to the person exposed. This implies that all hereditary harm, be it the early-appearing dominant or the very long-term recessive damage, is treated in exactly the same way and given exactly the same weight. Provisionally, and until our capacity to qualify hereditary radiation effects will improve, this seems the most reasonable decision to make.

Equally unsatisfactory is our inability to account for the type of genetic disorders which are most relevant in man, the non-mendelian multi-factorial disorders. Thus, we must take note - with some disappointment - that the slight apparent reduction of radiation-induced hereditary risk estimates observed over the years is due both to a decrease in our confidence to quantify part of this damage, and to a real decrease of the overall estimates. Future progress as to the relative contribution of these two components is expected to depend critically on advancements in fundamental human genetics, rather than in radiation genetics (UNSCEAR 1986).

THE MAIN GENERAL ASSUMPTION

The main general assumption on which radiation protection rests is that, at sufficiently small doses and dose rates, there is a non-threshold linear relationship between the dose and the probability of induction of late somatic and genetic effects. I am purposely using the word assumption because this statement cannot be scientifically demonstrated at the low doses that would be required. In fact, the relatively low incidence (per unit dose) of radiation-induced cancer and hereditary diseases is masked by a very

incidence (per unit dose) of radiation-induced cancer and hereditary diseases is masked by a very high background of other neoplastic and genetic conditions, that are unrelated with radiation exposure in excess of the natural level. This happens for two reasons. One is biological, because we have no means as yet of recognizing radiation-induced conditions from those that are caused by other agents. The second reason is statistical, because it is impossible, at the low doses and with the small populations usually available, to demonstrate the significance of a small number of supposedly radiation-induced health effects over a large number of effects of the same kind of uncertain etiology.

The implications of the non-threshold linearity assumption are clear. It postulates, in essence, that each dose of radiation, however small, has a finite probability of producing effects of the stochastic type; and that each dose increment, however minute, will increase this probability in a manner which is directly proportional to the increment. The two aspects need separate discussion.

The first aspect has to do with the absence of the threshold. Radiation protection is among the very few health-protection disciplines to postulate absence of threshold in the dose relationship for stochastic effects. In other fields of toxicology one usually identifies a level of dose that carries positive evidence of harm, and then sets the "safe" limit well below that level. Such a procedure implicitly assumes that the dose-effect relationship has some threshold below which the toxic agent is considered harmless. By excluding a threshold, radiation protection not only adheres to a probabilistic approach to risk assessment, but also implicitly refuses to consider small risks as irrelevant. In fact, even if they are sufficiently low to be of no relevance for the individual, they might not be quite so irrelevant as source-related collective risks. This is the reason why both the individual and the collective aspects of the risk must be considered in any assessment.

Going now to the ethical implications of the linear relationship between dose and probability of effect, there are justifications of a scientific nature for, and practical advantages in, this assumption.

Scientifically, we know that radiation energy is transferred to living matter along the tracks of ionizing particles. It seems reasonable to believe that, when the number of tracks per cell is on the average well below one (which happens at low doses and dose rates), single-track mechanisms giving rise to linear dose-effect relationships must be eventually the only ones operating, while double-track mechanisms (giving rise to quadratic relationships) must vanish. No matter to what extent linear relationships may be modified by various processes of repair of the initial damage, the kinetics will continue to be linear as long as the repair mechanisms will not themselves become dose-dependent, which only happens at very high doses and dose rates.

There are also practical considerations. On the one hand, in the presence of a high background level of radiation, linearity of risk due to a small dose increment is not an unacceptable proposition. On the other hand, postulating any non-linear relationships would imply the need of keeping track of the radiation history of each person, in order to calculate the attendant risk for each dose increment. Since radiation protection cannot clearly be tailored to each individual, the problem of assessing risks would have to be solved on the basis of large averages for and

between individuals, which would be equivalent to assuming linearity from the start. Finally, dose-related assessments and restrictions would be difficult, because the impact of each source would also depend on the exposure from other sources.

The question is then: if linearity between dose and the probability of stochastic effects is a scientific certainty or an inescapable practical necessity, where lies its ethical quality? It lies in the value assigned to the slope of the dose-linearity relationship, that is in the number we choose as the "nominal probability coefficient" for planning of radiation protection. Obviously, this value should not be too low, otherwise the resulting radiation protection requirements would not be stringent enough. Nor should it be made artificially low by applying correction factors (for dose and dose rate, for example) under conditions where dose and dose-rate effects are not operating: such an approach would equally result in less stringent standards of protection.

It is less obvious that the nominal probability coefficient should not be too conservative, particularly in the face of the inherent uncertainties. However, excessive conservatism would unduly penalize practices involving radiation in comparative exercises against other practices carrying health risks. Excessive conservatism may also result in an uneven - and therefore inefficient - distribution of resources available for protection against different sources of health risk. A realistic assessment of the coefficient is therefore to be advocated, in spite of the scientific and practical difficulties involved in such assessments. And the best way to achieve this goal is through reasonably frequent reviews of the scientific evidence and adjustment of the values as needed.

There are many ethical problems that could be discussed in connection with the assumption of non-threshold linearity. I will briefly touch on two.

The first problem concerns the existence of a variability in the appearance of stochastic damage among members of a population and the question for whom radiation protection standards should be developed. It is well established that susceptibility to cancer is not uniform, as shown by families with high predisposition to develop some tumour types. We also know that individuals homozygous for some genes are particularly sensitive to the immediate effects of radiation; and that cells in vitro that are homo- or hetero-zygous for these genes are also more radiosensitive than cells from normal individuals. What we ignore is whether people susceptible with respect to "natural" tumour induction may also be more prone to develop radiation-induced tumours; and we have as yet no easy way to identify people with abnormally high sensitivity to radiation; consequently, individual radiosusceptibility to cancer induction, and its distribution in the population, is an unexplored field.

Under these conditions, should radiation protection be planned with respect to the most sensitive or to the average member of the population? The answer is that probability coefficients for cancer induction are normally derived from people with all degrees of sensitivity. Thus, by using real epidemiological data as our reference point, we derive average values of population susceptibility, which include the most sensitive individuals. Such a procedure should be sufficient for planning of protection, provided that the distribution of genes linked with hypersensitivity could be dealt with individually in the context of occupational medicine.

The hypothesis of non-threshold linearity, among its many advantages, allows doses and probabilities of stochastic effects to be summed up in space and time. Integration in space I will consider later; here I am concerned (and this is my second question) with assessment of radiation effects in time, i.e., with the potential damage to future generations and how should protection be planned for exposures taking place late (and sometimes very late) into the future.

The question has many facets. There is first a general problem arising from the need of taking actions (of allowing actions to be taken) in the presence of uncertainties of different kind about the long-term future. To cite just a few, think of the uncertainties inherent to the inadequacy of the human mind to foresee long-term phenomena; or the uncertainties about the behaviour of any human group and the need to monitor the group's actions by independent evaluators. Other uncertainties arise in predicting the future of human societies and their degree of stability in the face of changing ethical values, political organizations, social structure, economic trends. And, finally, how can we reliably forecast the future of our environment and the modifications caused upon it by present and future human behaviour (Ethical Aspects on Nuclear Waste 1988)?

Then there is the question of our responsibilities to future generations and how to compare and value short-term effects with the very long-term damage resulting from present practices? Science is unable to suggest any answer to this kind of problem. Life is evolutionary by definition and the balance between species is unstable over long periods of time. There are no obvious ethical concepts to be derived from evolution and its mechanisms. Solutions to these problems must therefore be sought at a different level. If it is true that all human beings are equal regardless of ethnic, religious and national characteristics and that this right to equality could not be exercised without a right to a liveable environment, then there must be a principle of intergenerational equity by which we ought to respect the right of future generations by refraining from practices that may compromise their opportunities in the future. There is, in other words, an implicit social contract by which, since we derive from our ancestors our life and living means, we owe to our followers the same heritage we receive. We cannot obviously decide and plan for them, but we can at least avoid pre-empting their future decisions by giving them the same opportunities we received (Shrader-Frechette 1981).

These statements are clearly too general to provide practical guidance. To translate principles into practice, radiation protection charges to the account of present practices the commitment of any future somatic harm. It also attributes to the account of any exposed person all the hereditary damage - dominant and recessive, monogenic and polygenic - estimated on the basis of doses received by that person. By doing so, it gives exactly the same weight to all types of harm caused by an exposure received, now or in the future, irrespective of the time at which such damage will become manifest.

THE THREE GENERAL PRINCIPLES

Going now to the main principles of the ICRP system of dose limitation, I would like to preface the discussion by pointing out that the system is to be taken in its entirety and no one part (especially individual dose limitation) should be applied in isolation. One should also add what might appear redundant but, as the latin sentence goes, "repetita iuvant": just as it is necessary

that the scientific data leading to practical recommendations be assessed in a fair manner, it is also imperative that implementation of the system be undertaken in good faith. Periodic evaluations of its effectiveness should help to improve performance and to achieve, together with a gradual lowering of the overall doses, a more even distribution of them in space and time.

JUSTIFICATION OF A PRACTICE

In its most recent enunciation by the ICRP, the first general principle of radiation protection, that of justification of a practice, states that "No practice involving exposure to radiation should be adopted unless it produces sufficient benefit to the exposed individuals or to society to offset the radiation detriment it causes". At first sight, the principle appears utterly obvious: only a fool, in fact, could consider to undertake actions which are more harmful than beneficial. However, when closely examined, the statement appears very complex. Two concepts, benefit and detriment, are difficult to define and to apply to the other two terms, individuals and society.

The ethical problems posed by the interplay of these four terms are numerous. They turn, first of all, on how to define benefits in a comparable and consistent way and, above all, in a way which is fair to both individuals and groups. Secondly, who is to do this balancing operation and when? Thirdly, how should one compare radiation-related benefits and detriments with benefits and detriments induced by other practices?

Before discussing ethics, let us first be clear on some points: there is no wish on the part of radiation protection experts to take any of these decisions. In democratic societies, the role of balancing quantities and values of different nature, which are incommensurable by any rational standard, is left to people elected to exercise political authority. In stating this principle, radiation protection simply intends to put forward some requests: firstly, that the radiation-induced health detriment should specifically be considered as one element in the decision process; secondly, that the role of radiation protection specialists should not be that of choosing between a range of viable options, but that of advising about the viability of an option involving the use of radiation; and, fourthly, that judgements should not be taken once and forever, because options considered viable in a given context at a given time, may not continue to be so with changing conditions or the passage of time.

In general, estimates of all the consequences of a decision, beyond the most immediate ones, are extremely complex because they interplay with the primary or secondary results of other decisions, taken independently by other agents. In practice, therefore, one simply assesses the ethical quality of the most immediate consequences of a proposed decision, leaving aside the obscure chain of second- and third-order events and their possible interplay.

Similar arguments apply to the complexities of the socio-economic situations to be faced when making such decisions. Each individual belongs to different circles (family, group, work-force, nation, etc.) with different dimensions, aims and requirements. Circles of different order may cooperate or conflict with each other at any given time, and their interests may also change with time. Given such a high degree of complexity, how could one possibly trace what may be satisfactory or detrimental for each actor in the game of life? An open mind, reasonableness and

a balanced judgement are pre-requisites for fair decisions and these appear under such circumstances the most valuable ethical requirements.

One often regards the principle of justification as a very extensive one, involving decisions at the national or international level in respect to large programs of action: these are certainly the most striking cases to which the principle applies. However, justification of generalized medical practices involving exposure to radiation is a process of the same nature; actually, the principle of justification should apply to any single medical practice. It is true that any doctor carries out this process almost implicitly. It is also true that in medical practice benefits and risks accrue to the same patient, and this makes decisions somewhat easier. Furthermore, the risks of not

undertaking an examination are often more relevant than its potentially harmful consequences, i.e., medical practices are often heavily justified. But all these are simply secondary connotations of one and the same process of justification.

As a final note, it seems fair to ask that whoever has the responsibility of justifying a practice (from a clinician prescribing an x-ray examination, to a political body deciding upon a nuclear programme) should be well informed of the values at issue and the responsibilities at stake for all active and passive subjects of that practice. Personally, I am not satisfied that this is always so, and I am sure that many of you have often felt the same way. This is exactly why there is a need for the apparently obvious principle of justification.

OPTIMIZATION OF PROTECTION

I will now turn to the second basic principle, the optimization of protection. In its newest formulation this principle reads: "In relation to any particular source within a practice, the magnitude of individual doses, the number of people exposed, and the likelihood of incurring exposures where these are not certain to be received should all be kept as low as reasonably achievable, economic and social factors being taken into account. This procedure should be constrained by restrictions on the doses to individuals (dose constraints), or the risks to individuals in the case of potential exposure (risk constraints), so as to limit the inequity likely to result from the inherent economic and social judgements." The complications introduced into the new text are due to the deepening of the concept since the time it was first stated, to a novel attempt to enlarge it to include the so-called potential exposures, and to a desire to minimise the inequities in the resulting distribution of doses. All these, however important, are secondary technical specifications superimposed upon a general principle.

This stipulates that when attempting to minimize the doses received by individuals and groups, one comes to a point where further investments (of financial resources, staff, services, etc.) are grossly out of proportion with the doses saved. And, since optimization is not performed in a vacuum but in a world with limited resources, at that point it is no longer advantageous to invest for increasingly small returns. I should hasten to state that this process of balancing doses and resources takes place under a ceiling of doses that should not be exceeded deliberately under normal circumstances: these are the individual dose limits that must be met irrespective of cost.

The optimization principle is obviously modelled on utilitarianism, a philosophical theory that takes human general well being to be the foundation of morality. In its most extreme form, utilitarianism assumes that right actions are those that cause the greatest happiness to the greatest number of people, happiness being defined as the balance of pleasure over pain. It further assumes that it is possible to measure and to algebraically sum up pleasure and pain, and to take as the right action that which produces the least negative or the greatest positive balance (Engelhardt 1991).

To philosophers, the main merits of utilitarianism are its coherence and unselfishness, that provide a unitary procedure for morally correct decisions. But there are also objections: for example, it is really possible to quantify all the values to be balanced? Is the greatest total happiness the goal to be pursued or is the distribution of happiness also an important factor? For these and other reasons, utilitarianism is not universally accepted as a true ethical system (Mackie 1977).

To be sure, radiation protection adopts and recommends the concepts of the theory in a restricted sense, starting from the main premises; for example, human well being is given the more limited meaning of absence of effects on health. Radiation protection borrows the ideas of the theory simply as a device to counteract selfish interests on the part of individuals and groups against other individuals and groups. In other words, it uses its main principles as a methodology to help setting boundaries to the pursuit of narrow egoistic tendencies.

It is interesting to point out that the utilitarian theory, which is based on a purely aggregative principle, does not itself provide any precise answer regarding boundaries. The main criticism about the theory is actually that it is open to the possibility that the happiness of some may be reached through the misery of others. To avoid such a danger, a distributive principle must be added to the aggregative rule of the theory, to limit the unfairness (or at least

the most extreme unfairness) in the sacrifice of some for the sake of others. So much for the ethical foundations of utilitarianism.

Discussions on optimization must start from its objective, which is that of limiting exposure and thus decreasing the associated health detriment. If disease and suffering have the same value, irrespective of their etiological agent, it appears intuitively preferable to make the most out of the resources available. There is no apparent reason why, for the same amount of human detriment avoided, one should invest more resources to reduce radiation damage, while, for example, neglecting the prophylaxis of some infectious disease through vaccination, or the reduction of transportation accidents by an efficient communication system, or the cure of cardiovascular emergencies by increasing the number of intensive care units over the territory. All these are aspects of a well integrated system of health planning and should be looked at and cared for in a uniform manner to achieve a distribution of resources that avoids a maximum of detriment and suffering.

To help achieve optimization, a variety of formal decision-making techniques may be used. One of these, cost-benefit analysis, requires that the two quantities to be weighted against each other should be expressed in the same units, usually monetary units (ICRP 1983). This need has often

should add now) that is the variable that matters.

At the same time, it has been pointed out that probably the most correct way to project the occurrence of radiation-induced cancer into the future from present epidemiological data is through a multiplicative model in which the natural rate of induction and the radiation dose together determine the final outcome of a given exposure (an additive model had been used until now).

All these considerations and facts prompted the ICRP to adopt a different course of action in the selection of the limits. The Commission proposes now to enlarge the perspective of the exercise and to consider a wide range of attributes associated with radiation-induced effects (neoplastic lethal and non-lethal and severe hereditary conditions). These attributes are: the probability of death from effects over the entire life; the life time lost when radiation-induced death occurs; the combination of both these parameters, that is the reduction of life expectancy; and the increase in the probability of dying in each one year at any age, conditional upon having reached that age. Then the Commission calculates the value of the attributes at doses of between 10 and 50 mSv/year (corresponding approximately to 0.5-2.5 Sv in a working life time) and selects as the limit the annual dose that it considers just short of unacceptable.

There is obviously a degree of subjectivity in selecting such a value, but hopefully not a great amount of arbitrariness. It is important to spend one minute to illustrate the main points of the reasoning.

First of all, why set the limit at the level which is just unacceptable and not at one which is clearly acceptable? Because under the assumption of linearity without threshold the only dose acceptable without question is zero. This alternative would, therefore, reject all doses from man-made radiation and would also be meaningless in view of the high level of unavoidable natural radiation. On the other hand, setting the limit at a dose just short of unacceptable carries the corollary that to keep a worker continuously at the limit implies a risk which is definitely too high.

Secondly, new scientific evidence and its re-interpretation had shown that the nominal risk coefficient for tumours and genetic effects combined had increased since 1977. On the basis of the previous limit and of the new nominal risk coefficients, a worker continuously exposed at the limit would see his life expectancy reduced by about one year with an attributable probability of death of about 9%: these figures would universally have been regarded as unacceptable and the limit should have been decreased. The question is: how much?

To use the words of the Commission, the new limit should be such "that the total effective dose received in a full working life would be prevented from exceeding about 1 Sv received moderately uniformly year by year and that the application of its system of radiological protection should be such that this figure would only rarely be approached". On this basis "the Commission now recommends a limit on effective dose of 20 mSv per year, averaged over 5 years (100 mSv in 5 years), with the further provision that the effective dose should not exceed 50 mSv in any single year".

I would be lying to you if I should claim that this decision was an easy one to make. It was a compromise just short of unacceptable to any of those who had to take it and came to be judged as tolerable for the Commission as whole, with various shades of dissatisfaction. But this is inevitable: as I said before, when deciding on these matters each person carries his own human, cultural and professional sensitivities which add to the logical line of thought (and I specifically mean adding in the sense of enriching). My own tendency would have been more restrictive, and therefore I have to remind myself all the time that limits are recommended for universal use and should cut across the needs of various groups and societies. They are suggested values, that individual countries may accept or reject, hopefully to adopt lower limits. Actually, the system itself recommends various ways to reduce the risk implied by the primary limits.

As to the limit of dose for the public, the ICRP proceeds in analogy with that for workers. It still aims at a dose level just short of unacceptable for continuous exposure and it still assesses the limit by comparing various attributes of lethal, non-lethal and hereditary harm. It comes eventually to a recommended level of 1 mSv per year. An alternative procedure, that of selecting a fraction of the natural background to be the limit would have been unacceptable in principle, because the fact that we are exposed to doses from natural radiation sources (even with ample fluctuations in space and time) cannot in principle justify the addition of any dose, however small, from man-made sources. Comparisons with background are useful a posteriori, but would be unwarranted a priori for the purpose of selecting limits.

The choice for the public of a limit which is considerably smaller than for the workers (about a factor of 20, at present) is ethically justified on the grounds that this limit applies to a much larger population, that exposure is for the whole life (and not only for the working life); and that the public at large includes here also the most susceptible young ages. Also, members of the public are only protected by source control and not by individual monitoring. All these considerations make sense from a general point of view. What is more perplexing to me is why workers should in theory be allowed (as they in practice do) to receive higher doses than other members of the public of the same age. Explanations usually given are that workers are paid to do a given job, but my objection is that this implies acceptance of the concept that a potential risk to human health and life may be traded for money. It is also said that workers undergo the relevant risks voluntarily as a matter of free choice. But is this true under conditions of high unemployment? And, in any case, is it fair to ask anybody to choose between no work and work under high risk?

The fact does remain that limits for professional exposure are normally higher than for public exposure for many human activities. I have no argument to oppose the wide public acceptance of this state of affairs. It could be an excess of scruples on my part, and it could be utopian and unrealistic even to contemplate such an idea: but I would eventually like to see a system in which each person is protected as a human being, irrespective of any working condition. And I believe that on this point there is room for further improvements.

CONCLUSIONS

At the end of this presentation, I should try to answer the question that has long been in my mind and perhaps in your mind too, since I started the present talk. Is the present system of radiation protection founded on sound ethical grounds? Overall, I believe that the answer should be yes, because the ethical propositions on which it is founded are good; the methodologies to develop the basic principles into a set of recommendations are morally acceptable; and the system appears reasonably coherent, flexible, stringent enough to keep the risks low, but not zero, which would be an impossible target to achieve, as long as there are benefits to be gained from the use of radiation.

Naturally, as is true of all human endeavour, the system could still be improved. Some improvements will come about in due course as new experience is gained. This applies, for example to the updating of risk estimates based on new scientific evidence. From it, as in the past, revision of the present recommendations will probably derive.

Other improvements will presumably require original research and development in order, for example, to further clarify the meaning of the principle of justification, or to include environmental, in addition to human, protection.

To meet further and more advanced requests, revolutionary, rather than evolutionary, approaches of the present system might be necessary. I am referring here to my suggestion to protect individuals as human beings and not as workers and public; or to the further universalization of the basic ethical principles to take into account non-objective health detriment and other preferences, desires or ideals.

Such further developments would almost certainly make the system more stringent. As it become so, some people may find it more acceptable but others may look upon it as too obtrusive. We certainly should ask ourselves whether we have taken the present system as far as it could go in order to preserve coherence, which is undoubtedly its main merit. On the other hand, we must see that protection against radiation is not pushed too much, because it may fall out of perspective and be unfairly penalized in comparison with protection against other health hazards.

My personal feeling at present, from a global perspective, is that adoption of the system, imperfect though it may be, by all countries would be likely to save more doses than might be saved by further marginal improvements in countries where the system is already well in operation. If this feeling is correct, then we should continue working, as we have done in the past, in order to develop the system rationally, while trying all the time to behave reasonably.

Acknowledgements. I am greatly indebted to a number of friends who discussed with me some of the points or made useful comments to the original manuscript. They are: dr. C. Bresciani, dr. L. Frittelli, dr. O. Ilari, prof. B. Lindell and dr. F. Sella.

REFERENCES

- Engelhardt H.T. *Manuale di Bioetica*. Milano, Mondadori; 1991 (in Italian).
- Ethical Aspects on Nuclear Waste. Salient points discussed at a seminar on Ethical Action in the Face of Uncertainty. SNK Report 29, Stockholm; 1988.
- International Commission on Radiological Protection. Recommendations of the ICRP. Oxford: Pergamon Press; ICRP Publication 26; Ann. ICRP 1(3) 1-53; 1977.
- International Commission on Radiological Protection. Cost-Benefit Analysis in the Optimization of Radiation Protection. Oxford: Pergamon Press; ICRP Publication 37; Ann. ICRP 10(1) 1-55; 1983.
- International Commission on Radiological Protection. Optimization and Decision-making in Radiological Protection. Oxford: Pergamon Press; ICRP Publication 55; Ann. ICRP 20(1) 1-60; 1989.
- International Commission on Radiological Protection. 1990 Recommendations of the ICRP. Oxford: Pergamon Press; ICRP Publication 60; Ann. ICRP 21(1-3); 1-201; 1990.
- Mackie J.L. *Ethics, Inventing Right and Wrong*. London: Penguin Books; 1977.
- Reich W.T. (ed.). *Encyclopedia of Bioethics*. New York: Georgetown University Free Press; 1978.
- Shrader-Frechette K. *Environmental Ethics*. Pacific Grove, California: Boxwood Press; 1981.
- Silini G The problems of establishing a biological basis for the assessment of radiation risks. In: *The Interface in Nuclear Safety and Public Health, Proceedings of a NEA seminar*. Paris, OECD; 1991: 33-46.
- UNSCEAR 1982 Report. Sources and Effects of Ionizing Radiation. United Nations Sales Publication No. E.77.IX.1. New York; 1977.
- UNSCEAR 1986 Report. Genetic and Somatic Effects of Ionizing Radiation. United Nations Sales Publication No. E.86.IX.9. New York; 1986.
- UNSCEAR 1988 Report. Sources, Effects and Risks of Ionizing Radiation. United Nations Sales Publication No. E.88.IX.7. New York; 1988.

COMPARABILITY OF RISK

Chris J. Huyskens

Eindhoven University of Technology, Radiation Protection Department
P.O. Box 513, 5600 MB Eindhoven, The Netherlands

INTRODUCTION

The concept "risk" means different things to different people. When technocrats judge risk in their field of expertise, their responses correlate highly with quantitative estimates of probabilities. However, judgements and interpretations by non-experts attach much more importance to cognitive dimensions of perception. Risk evaluation by quantitative risk assessments or by risk perception should not be regarded as competitive but as complementary.

CONCEPT OF RISK

A great deal of discussion is often devoted to formulating "a proper definition of risk". Literature shows that there is an enormous variety of definitions and interpretations [2, 3, 5, 6, 8].

In health related sciences "risk" is often addressed as a multi dimensional combination of harmful health effects and their probabilities. In technological safety analysis, "risk" usually is expressed as a mathematical representation of probabilities of undesired events. In non-technology related sciences, interpretations are close to the loose meaning in every day language, referring to the threat of undesired events or the dread of harmful consequences. These different interpretations of risk cause considerable confusion in risk communication.

Quantitative definitions for any risk parameter in assessment studies should fulfil the conceptual requirement that they provide information about the basic triplet of risk components: scenario, probability and consequences [3].

- The "scenario" identification refers to the question "what can happen or what can go wrong?".
- The "probability" issue which refers to the question "how likely is it that things will happen?"
- The description of "consequences or measures of damage, which should answer the question "if it does happen, what are the consequences?"

The complexity of such a concept, especially because of each of these three components is of a multi dimensional nature in itself, leads to the necessity of simplification. Any definition of risk is conceptually adequate as long as it addresses all three fundamental components. Otherwise risk assessment or risk evaluation is impossible.

REDUCTION OF COMPLEXITY

It is a trivial statement that reduction of complexity of reality goes hand in hand with simplification. This is legitimate, because it is a necessary requirement to manage the complexity of risk assessments. However, one must realize that each step of simplification incorporates choices, value judgements or even policy judgements.

TYPOLOGY OF RISK DEFINITIONS [2]	TYPOLOGY OF COGNITIVE RISK DIMENSIONS [2,4]
<ol style="list-style-type: none"> 1. Uncertainty about safety or health 2. Possibility of undesired consequences (loss, damage, injury, death) 3. Lack of perceived controllability of a practice 4. Conditional probability - (mathematical expectation) - of a single type of harm (or loss) 5. Frequentistic presentation of a mono-dimensional index of harm 6. Multi attributive weighted aggregate of probabilities and consequences (utility theory) 7. Multi dimensional presentation of probabilities and consequences 	<ol style="list-style-type: none"> 1. Character and severity of harm or consequence 2. Controllability and influencibility by prevention and mitigation 3. Number of population at risk 4. Familiarity with consequences or activities 5. Voluntariness, intentionality and degree of involvement 6. Persistence, delay and transgenerational aspects

Any choice of definition and any choice of methodology in risk assessment is influenced by cultural, professional, institutional or even policy considerations. For this reasons Fischhoff [5] calls the choice for definition "a political act", which like any other choice in policy issues is inherently controversial. The choice of a risk parameter and the choice of methodology influences the outcome of any analysis and subsequently also influences conclusions and decisions. This is not meant as a criticism, but as a warning. Many risk analysts pretend that quantitative risk assessment is objective. This in my view, is not correct. Because even the choice of a risk definition or quantity is a value judgement in itself. There exists no dichotomy between subjective or objective risk evaluations. What does exist is a distinction between (i) quantitative risk assessment methodologies which assign preferential choices to the use of quantifiable parameters as simplified representations of risk and (ii) qualitative socio-psychologic methodologies which predominantly address the cognitive dimensions of risk perception. It is a matter of fact, proven by extensive psychological research that qualitative risk perception is generally uncorrelated with quantitative risk assessments [1, 2, 4, 5].

QUANTIFICATION

In quantitative risk assessments, the complex nature of risk is reduced by the choice of a highly simplified risk parameter. The ultimate simplification is reflected in probability assessments where only one single component of health detriment or harm is taken into account. Proponents of such simplified approach, especially amongst technocrats and policy makers, argue nevertheless that such a single dimensional "yard stick" of risk is suitable for policy decisions, because they assume such risk quantity is measurable. Most of these focus on mathematical representations for probability. The underlying assumption is of a typical technocratic nature. It is assumed that interpretation and comparison of numbers is more objective than any qualitative approach. What I wish to stress here, is that any choice of a quantifiable parameter to characterize only a few or even one single isolated aspect of risk, involves subjective judgement and therefore puts restrictions on the utility and significance of such quantitative risk estimates.

Further it must be realized that the probability aspect of risk in itself is of a multi dimensional nature. Distinction must be made between the "stochastic" probability of occurrence of hazardous events, the "frequentistic" probabilities that such events will lead to exposure and further the "conditional" probability that such exposure may result in harmful consequences. Technocrats sometimes seem to forget that probability does not merely refer to frequency, but that it also reflects subjective probability aspects by "best estimates" and "expert judgements". This variety of interpretations of probability implies a warning against aggregation into a single "probability estimate".

CETERIS PARIBUS

Interpretation and comparison of quantitative risk estimates become meaningless or even misleading when it is not guaranteed that respective practices or situations are otherwise comparable. This so called "ceteris paribus" principle requires that all factors, circumstances and assumptions that are not explicitated in the outcome of risk quantification, shall be mutually equivalent. This means that all technological, physical, biological and social descriptors shall not be essentially different. This "ceteris paribus" principle implies that quantified probability estimates must regard the same type of consequences as well as the same nature of scenarios. The required equivalence of consequences is a very restrictive constraint to the comparability of probabilities, because there exists not only a large variety of essentially different consequences, but each of them has widely different arguments. Even when only health detriment is considered, there still remains a variety of components.

Well-known examples of (apparently) single dimensional risk quantities are (a) fatal accident frequency rate - FAFR, (b) frequency of death per person year, (c) uniconhort and (d) loss of life expectancy. Each separately these quantities provide an extremely narrow and biased view on risk. For this reason they are hardly intercomparable. Covello et al. [8] emphasize this by explicit warning that "use of such data for risk comparison purposes can severely damage your credibility".

The multidimensional character of damage and harm shows somewhat better in multi attribute utility techniques. There risk is defined as a weighted combination of value judgements over the various attributes of harm. This can be described as a vector presentation in which each element or dimension represents a quantifiable attribute, such as probabilities and magnitude of consequences. The overall risk is then evaluated as the weighted sum of scores on different attributes. It seems often forgotten that such quantitative approach can be highly sensitive to small variations in weighting factors or the choice of attributes [5].

PERCEPTION

The limited comparability of quantitative risk estimates has clearly emerged in psychological research on risk evaluation. The impact of so called cognitive dimensions of risk, is apparent. Such descriptors are of a physical, biological and social character. The typology of cognitive dimensions is more of an effect related nature [2, 4, 7] and includes (i) the threat to biosphere, (ii) the threat to human health, (iii) the catastrophic nature of consequences, (iv) the intentionality and voluntariness of risk, (v) the distribution in time and space.

The major conclusion from psychological surveys is that people do not deal with risks in a consistent manner. The main arguments of the apparent great variety in risk perception and risk judgements are reasonably well-understood [1, 2, 7]. There exist a variety of mutually incommensurable, unequal interpretations and notions of the concept of risk and the extent of the problem analysis. Public perceptions of risk differ from assessments by experts. What is even more important is to recognize that perceptions can seem indifferent to risk communication. Additionally there are two other issues of main importance. At first, there is the issue of "equity". This involves problems about the fairness with regard to unequal distribution of benefits on one hand and cost and risk of a practice on the other hand. Further there is the issue of individual and collective partiality. Prejudice, with regard to the nature of the practice or situation as well as with regard to the type of harm or consequences. Especially where it involves large scale practices and low-probability - high-consequence type of activities, social political views and selective preferences are so extremely dominant that they cannot be implied in risk assessment methodology. Decision making then requires procedures which pay utmost care to social balance and acceptance. The role of risk comparison and risk assessment in such decision making processes is very limited, if at all existent.

CONCLUSION

The issue of comparability of risk is dominated by the following issues:

- the choice of definition; technocratic quantitative interpretations of risk are not by definitions objective. Any simplified risk definition implies value judgements.
- the scope of the problem; comparison of partial components of risk is more meaningful than presentation of absolute numbers. The pursuit of a unified, one dimensional risk quantity is unrealistic. It is a misjudgement of the gap between technocratic risk assessment and public risk acceptance.
- the "ceteris paribus" principle is an essential requirement for any risk comparison; the required equivalence of conditions is a very restrictive constraint to the comparability of numerical estimates.
- risk quantification and risk perception are uncorrelated; it is a requirement for risk management and risk regulation to imply both components in the structure of decision making. Risk quantification is predominantly a source or practice related assessment, while risk perception is highly consequence and effect related. They both rely on implicit value judgements. Explication of such hidden dimensions of risk is an essential requirement for comparability.

REFERENCES

- [1] Slovic P. Perception of Risk from Radiation. NCRP Proceedings No. 11. National Council on Radiation Protection, Bethesda; 1990.
- [2] Vlek Ch. Decision making about risk acceptance. National Health Council, the Netherlands; 1991.
- [3] Kaplan S. and Garrick B.J. On the quantitative definition of risk. Risk Analysis, Vol. 1, No. 1. pp. 11-27; 1981.
- [4] Hohenemser C., Kates R.W. and Slovic P. The nature of technological hazard. Science, pp. 378-384; 22 april 1983
- [5] Fischhoff B., Watson S.R. and Hope C. Defining Risk. Policy Sciences 17, pp. 123-139; 1984.
- [6] Cohen B.L. Catalog of risks extended and updated. Health Physics Vol. 61, No. 3, pp. 317-335; 1991.
- [7] Shrader-Frechette K. Risk analysis and scientific method. Reidel; 1985.
- [8] Covello V.T., McCallum D.B. and Pavlova M.T. Effective risk communication. Plenum Press, New York and London; 1989

BILAN D'UNE ETUDE REGIONALE SUR CERTAINES NUISANCES SUBIES PAR LE PUBLIC

ANGUENOT F., AIGUEPERSE J., HARDY S.

CEA/Institut de Protection et de Sécurité Nucléaire/Département de Protection de la Santé de l'Homme et Dosimétrie; Fontenay-aux-Roses, France.

ANALYSIS OF A COMPARATIVE PUBLIC RISK ASSESMENT STUDY

ABSTRACT :

The main aim of this study has been to inventory the risks existing in a region (South East of France) so as to compare different activity sectors within geographic units of varying size. The overall data obtained shows that the mean annual radiological and chemical exposures do not result in a marked health risk for the sources considered, except for pollutants produced within the home, for which levels may exceed occupational exposure limits for periods of several days, or even weeks.

1 - INTRODUCTION

Cette étude (Programme Grand Delta) est développée depuis 1980 à l'IPSN. La région choisie est représentative du territoire national : 1/5 de la surface, 1/5 de la population (10 millions d'habitants) et les principales activités y sont représentées. Ce très vaste sujet n'a pu être traité de manière exhaustive. L'essentiel de l'étude a concerné le risque chronique et, plus précisément celui lié à la production électrogène (charbon, fioul, uranium), aux chauffages résidentiel et tertiaire, à la pollution à l'intérieur de l'habitat, à l'irradiation naturelle et à l'irradiation due au radiodiagnostic. Au cours de ces études, seules ont été prises en compte les nuisances créées par les activités qui s'exercent au sein de la région Sud-Est de la France. L'exposition calculée (dose intégrée délivrée aux populations) correspond à une durée de fonctionnement des installations de 30 ans. A chaque fois que cela s'est avéré possible, l'exposition a été corrélée à un effet sanitaire. Cela suppose l'existence d'une relation exposition-effet particulièrement délicate à établir, et qui en fait n'existe que très rarement pour les produits chimiques.

2 - METHODOLOGIE ET RESULTATS

La méthodologie utilisée découle directement de celle mise en oeuvre pour les études d'impact sur l'environnement des installations soumises à autorisation. Elle se résume en trois phases successives : évaluation des émissions, des expositions et des conséquences sanitaires. La description détaillée de ces évaluations a fait l'objet de publications [1,2].

2.1. Emissions

Les quantités de polluants émises par les installations des cycles électrogènes ont été, soit fournies par les industriels, soit obtenues à la suite de campagnes de mesures à l'émission, soit, à défaut, à partir de données publiées dans la littérature internationale. Dans le cas du chauffage résidentiel, l'évaluation des émissions tient compte, d'une part de la distribution de la population, des habitations et du mode de chauffage, et, d'autre part des consommations de combustibles de la région. Les consommations départementales du chauffage tertiaire ont été ventilées dans les seules zones urbaines. Les émissions à l'intérieur de l'habitat ont été caractérisées expérimentalement. Une soixantaine de produits a été analysée représentant 8 types d'utilisation différentes. Pour chacune d'elles, l'ensemble des produits analysés représente au moins 75% des ventes sur le marché français. Les émissions d'un foyer ouvert, simulant un feu de cheminée, ont été déterminées au cours des différentes phases de la combustion du bois (allumage, combustion, braises, ajout d'un morceau de bois).

2.2. Expositions

Rejets atmosphériques : les concentrations résultantes dans l'environnement sont évaluées à l'aide d'un modèle de dispersion atmosphérique de type panache gaussien simplifié qui tient compte de facteurs d'appauvrissement du panache : les dépôts sec et humide, les décroissances et filiations radioactives, ainsi que la transformation physico-chimique du SO₂ en sul-

fates. Les situations météorologiques des 12 stations concernées sont des moyennes sur 25 ans pour chacune d'elles. Les concentrations moyennes annuelles sont présentées dans un système de mailles de 100 km² issu de la grille européenne (mailles de 10.000 km²) mise au point à l'IPSN. Dans chacune de ces mailles, la concentration de chacun des polluants rejetés par l'ensemble des installations concernées est cumulée. L'exposition des populations est ensuite évaluée pour chacun des polluants et chacune des principales voies d'atteinte : directe (inhalation, exposition externe) et indirecte (ingestion par la chaîne alimentaire).

Rejets liquides (uniquement pour le cycle de l'uranium) : le Rhône est divisé en 9 tronçons dans lesquels les caractéristiques hydrodynamiques sont considérées comme constantes. Les expositions individuelles et collectives ont été calculées pour les principales voies d'atteinte à l'homme : eau de boisson, consommation de poissons et de produits irrigués, exposition externe. Pour évaluer l'exposition collective, on considère que toute la production agricole et piscicole est consommée par la population de la région sans tenir compte de la distribution géographique.

Radiodiagnostic (radiologie dentaire et radiodépistage systématique exclus) : l'évaluation de l'exposition collective et l'estimation de la dose moyenne par habitant dans chacun des départements composant la région étudiée, sont issues d'une étude effectuée au niveau national [3].

Radioactivité naturelle : la cartographie étudiée par l'IPSN étant incomplète pour les départements de la région étudiée, on a utilisé la valeur de 2 mSv/a proposée par l'UNSCEAR [4].

Intérieur de l'habitat : les concentrations résultantes dans les pièces d'un habitat à la suite de l'utilisation de produits domestiques ont été calculées à l'aide d'un modèle simplifié de transfert atmosphérique selon différents scénarios d'utilisation [2]. Si le facteur d'émission est une fonction du temps, les concentrations sont recalculées en tenant compte de la fonction d'émission déterminée expérimentalement. Les concentrations résultantes de la combustion de bois en foyer ouvert ont été mesurées dans la pièce à différents stades de la combustion à 1,5 m du foyer.

2.3. Effets sanitaires

Exposition radiologique

Compte tenu de la précision associée aux évaluations des expositions, on a admis, à partir de la CIPR 26, 0,01 effets stochastiques d'origine somatique par homme.Sv et 0,02 effets stochastiques somatiques et génétiques par homme.Sv.

Le nombre d'effets sanitaires calculé pour le public du Sud-Est de la France qui résulterait des rejets atmosphériques et liquides de radionucléides des installations des cycles énergétiques est de l'ordre de 0,1 pour le cycle de l'uranium et de 0,002 pour les centrales thermiques fossiles. Compte tenu des installations effectivement en activité dans la région en 1987, le nombre de ces effets est faible comparé à celui dû au radiodiagnostic (35) ou à l'irradiation naturelle (200). A titre de comparaison, le nombre de décès par tumeur enregistré en 1987 dans cette région est de l'ordre de 30.000 et représente environ 25% de la mortalité régionale, pourcentage comparable à la moyenne nationale.

Les valeurs annuelles maximales déterminées pour un groupe fictif recevant toutes les expositions maximales issues des installations des cycles électrogènes sont bien inférieures à la recommandation de la CIPR pour le public (5 mSv/a) et à la valeur moyenne annuelle retenue par l'UNSCEAR résultant de l'exposition naturelle (2 mSv).

Exposition chimique

Il n'existe pas, pour les polluants chimiques, d'indicateur unique de nuisance comme c'est le cas pour les produits radioactifs. Trois approches ont donc été suivies en fonction des données scientifiques disponibles et de leur pertinence :

- évaluation de la quantité incorporée dans un tissu ou organe cible ou dans l'organisme entier, quantité que l'on compare à celle présente chez un homme standard de 70 kg ou à une valeur seuil à partir de laquelle apparaît un dommage;
- évaluation d'un excès de mortalité ou de morbidité lorsqu'une relation exposition-effet a été établie. Si elle est de type linéaire sans seuil, les effets sont calculés, comme pour les radionucléides, à partir de l'exposition collective annuelle régionale exprimée en homme.µg/m³.
- comparaison à des valeurs limites d'exposition dans l'environnement ou plus souvent à des recommandations pour la santé du public. A la différence des radionucléides, on n'a pas distingué, en l'absence d'indicateur unique de nuisance, un "groupe référence" qui aurait reçu toutes les expositions maximales. Mais notons que la comparaison aux valeurs limites d'exposition répond en partie aux questions que l'on se pose quand on a recours à la notion de "groupe référence".

La surmortalité théorique calculée pour l'ensemble SO₂ et sulfates émis par le cycle électrogène d'origine fossile (centrales thermiques et raffineries) et les chauffages résidentiel et tertiaire atteint environ 100 décès dont 80% seraient dus au chauffage résidentiel. Un résultat identique est obtenu avec les poussières. Les concentrations de SO₂ et de poussières calculées dans les mailles (10⁻³ à 10 µg/m³), qu'elles résultent du cycle électrogène d'origine fossile, ou du chauffage résidentiel ou tertiaire, sont inférieures à la valeur guide de l'OMS (50 µg/m³) relative aux effets combinés du complexe SO₂-poussières [5].

Pour les métaux-traces émis par les centrales thermiques fossiles, en appliquant les relations exposition-effet données par l'OMS [5], le nombre de cancers calculé est inférieur à 1 pour l'ensemble arsenic, chrome (assimilé à Cr VI) et nickel. Pour le cadmium, les quantités stockées dans le cortex rénal (tissu cible) de la population sont bien inférieures (10⁻⁴ à 2.10⁻² µg/g) à la valeur à partir de laquelle peut apparaître un dommage pour le rein (200 µg/g de cortex rénal). Les quantités de nickel stockées dans l'organisme s'échelonnent de 1,7.10⁻⁵ à 8,5.10⁻³ µg par kg corporel. Elles sont très inférieures à la valeur observée chez l'homme standard, soit environ 7 µg par kg corporel. Pour l'ensemble des métaux traces émis, les concentrations calculées dans les mailles de 100 km sont très inférieures (10⁻⁸ à 10⁻⁶ µg/m³) aux valeurs guides recommandées par l'OMS [5].

Les concentrations calculées dans les pièces d'un habitat standard, compte tenu de différents scénarios d'utilisation des produits domestiques, peuvent dépasser les valeurs limites d'exposition professionnelle pendant plusieurs heures (toluène : utilisation de colle de revêtement à base organique), voire plusieurs jours (naphthalène et triméthylbenzène : application de cires). L'exposition au 1,4-dichlorobenzène (p-DCB) émis par les blocs WC désodorisant d'atmosphère peut quelquefois conduire à une probabilité de risque légèrement supérieur à 10⁻⁶ [6]. Enfin, les concentrations d'hydrocarbures polycycliques aromatiques, reconnus cancérigènes, émis par un feu de bois et mesurées dans la pièce à 1,5 m du foyer, peuvent atteindre des valeurs élevées au début de la combustion : benzo(a)anthracène + Chrysène (189 ng/m³), dibenzo(ak)anthracène (83 ng/m³), benzo(a)pyrène (70 ng/m³) et benzo(b)fluoranthène (58 ng/m³). Ces valeurs sont au moins divisées par 10 en fin de combustion.

3- DISCUSSION ET CONCLUSION

Le principal objectif du programme Grand Delta a été, dès son origine, de dresser un inventaire des risques d'une région en faisant en sorte que l'on puisse établir une comparaison entre secteurs d'activité au sein d'unités géographiques plus ou moins grandes.

La première difficulté rencontrée a été l'obtention des données indispensables à la première phase de l'étude, à savoir, la connaissance des émissions relatives aux activités répertoriées. A ce jour, ce problème existe toujours malgré la volonté des autorités d'obtenir une plus grande transparence. Une banque de données a tout de même pu être constituée à l'aide des informations des exploitants, de mesures, ou encore d'estimations à partir de la littérature internationale en l'absence d'autre

solution. Ces données relatives au cycle électrogène, aux chauffages résidentiel et tertiaire, au radiodiagnostic, à l'irradiation naturelle et à la pollution à l'intérieur de l'habitat, ont, pour certaines d'entre elles, été utilisées dans des modèles de transfert à l'environnement : air, eau et sol. Il est évident que ces modèles ne peuvent fournir qu'un ordre de grandeur comparé aux mesures réelles dans l'environnement. Ils sont cependant le passage obligé car il est impossible d'implanter, au niveau d'une région, suffisamment de capteurs pour mesurer la concentration moyenne annuelle de chacun des polluants existant.

Une fois estimées les concentrations dans les divers milieux, il faut caractériser l'atteinte à l'homme qui constitue la finalité de l'étude. Pour cela, il faut recourir à d'autres modèles décrivant le métabolisme du polluant inhalé ou ingéré et définir les coefficients de transfert (poumon → sang, absorption intestinale...). On sait que les "constantes biologiques" varient en fonction des formes physico-chimiques de l'élément considéré. Une nouvelle fois, on n'accédera donc qu'à un ordre de grandeur de la quantité de polluant transféré.

Toutes ces remarques ont pour but d'attirer l'attention de l'utilisateur éventuel de ces résultats sur les réserves qu'il faut apporter dans leur exploitation en tant que valeurs vraies dès que l'on parle d'effets sanitaires associés calculés. Ceci d'autant plus que contrairement à l'exposition radiologique il n'existe pas, pour les polluants chimiques, d'indicateur unique de nuisance et que seules quelques rares relations exposition-effet sont utilisables.

Il n'en est pas de même pour les analyses relatives aussi bien aux résultats entre eux (différents scénarios, différents filières) qu'à leur comparaison à des valeurs références (quantité présente chez l'homme standard, valeur seuil à partir de laquelle apparaît un effet, concentration moyenne dans l'environnement...). Le bilan de cette étude se matérialise donc, bien plus par une mise en perspective des risques chroniques résultant de différentes activités que par une évaluation absolue des effets sanitaires qui en résultent.

L'ensemble des résultats obtenus montre qu'en moyenne annuelle, les expositions radiologiques et chimiques ne conduisent pas à un risque sanitaire important pour les sources considérées à l'exception des pollutions générées à l'intérieur de l'habitat pour lesquelles, sous certaines conditions, les valeurs limites d'exposition travailleur peuvent être dépassées, et ce, pendant plusieurs jours voire plusieurs semaines.

REFERENCES :

- [1] COULON R., AIGUEPERSE J., ANGUENOT F. - The impact of conventional and nuclear industries on the population: a comparative study of the radioactive and chemical aspects - Report EUR 10557 FN (1988).
- [2] AIGUEPERSE J., ANGUENOT F., HARDY S. - Evaluation comparative des risques au niveau régional - IPSN/DPS (1990).
- [3] BENEDETTINI M., DEGRANGE JP., MACCIA C., LEFAURE C. - Evaluation de la dose collective liée au radiodiagnostic dans la région Sud-Est de la France en 1982 - Rapport CERN n°74 (1984).
- [4] UNSCEAR United Nations Scientific Committee on the Effects of Atomic Radiation - Ionizing radiations: sources and biological effects - United Nations, New York (1982).
- [5] WHO Regional Office for Europe - Air Quality Guidelines for Europe - WHO Regional Publications, European Series n°23 (1987).
- [6] BONVALOT Y., ABENHAÏM L. - Evaluation quantitative du risque cancérigène de certaines substances chimiques présentes dans les désodorisants d'atmosphère - Programme Grand Delta, IPSN (1990).

REMERCIEMENTS :

Le "Programme Grand Delta" a été supporté par deux contrats communaux : B10.F.320.81.F et B16.F.121.F entre la CCE (DG X11) et le Centre de Développement des Etudes et Applications en Hygiène et Sécurité (CEDHYS) et par un contrat dans le cadre de l'action "Habitat-Santé" du Programme Polilog (Plan construction et Architecture et les Ministères chargés de l'Environnement (SRETE), de l'Education Nationale et de la Santé).

INFORMATION DES MEDECINS A PROPOS DES RISQUES NUCLEAIRES :
EXPERIENCES DES INDUSTRIES ELECTRONUCLEAIRES
FRANCAISE, BELGE ET ALLEMANDE

Drs M. Bertin*, J.M. Cordier** , D. Hubert*
J. Lallemand* , H. Pfob** , G. Heinemann***

*Electricité de France - Comité de Radioprotection
Paris, France

**Directeur - C.B.M.T. (Centre Belge Médecine du Travail)
Bruxelles, Belgique

***Directeur du Service Médical de la Badenwerk AG
Karlsruhe, Allemagne

****Directeur du Service Médical de la Preussen Elektra
Stade, Allemagne

INFORMATION ABOUT RISKS OF NUCLEAR POWER PLANTS
PROPOSED BY NUCLEAR INDUSTRIES TO MEDICAL DOCTORS
IN FRANCE, BELGIUM AND GERMANY

ABSTRACT

Information and post-graduate training of the medical profession are performed in continuation of academic studies and should endeavour to respond to the concrete questions that physicians have in mind and may have to deal with. They must strive to emphasize this distinctive and somewhat new role of the doctor that consists in putting a premium on health education at the expense of the only therapeutic role. This aspect of radiological urgency is liable to affect physicians as frustrating, which may, at least partly, account for the widespread impression among a strong majority of them in our 3 countries that they are still insufficiently informed, despite the effort conducted for many years by the physicians of the nuclear electricity utilities. France, Belgium and Germany have adopted the same approach.

INTRODUCTION

La radioprotection repose sur un ensemble de principes qui, au delà du respect de la réglementation, visent à intégrer cette protection dans la conception des installations, la préparation du travail, la formation approfondie et sans cesse réactualisée des agents mais également l'information du monde extérieur. L'accident de Tchernobyl a montré qu'une information utile en temps de crise ne peut se faire que si elle est précédée d'une information préalable de qualité pour bénéficier auprès du public d'une légitimité et d'un "capital confiance". A cet égard, le médecin et l'ensemble des professions médicales et paramédicales constituent sans doute un interlocuteur important car ils sont considérés par le public comme des

personnes compétentes aptes à donner des conseils avisés sur les activités potentiellement "dangereuses" pour la santé. Les professionnels de la santé réclament tous une information de qualité et le but de cette communication est :

- de décrire les besoins d'information et les actions menées depuis de nombreuses années auprès du corps médical et paramédical par les médecins des entreprises électronucléaires ;
- de comparer les approches retenues par la France, la Belgique et l'Allemagne, dont les motivations et les moyens sont très proches et se confondent dans certains cas, par exemple l'information transfrontalière des médecins et pharmaciens français, belges et allemands résidant autour des centrales nucléaires de Chooz et de Cattenom ;
- de souligner le rôle d'interface privilégié que peut et doit jouer le médecin du travail ;
- enfin, d'insister sur l'aspect spécifique de l'urgence nucléaire. Le rôle du médecin, en cas d'urgence radiologique, est surtout un rôle d'information, d'explication, de conseil, de dialogue avec les experts alors que les gestes médicaux sont réduits à peu de choses. Cet aspect particulier de la conduite à tenir doit être pris en compte.

LA DEMANDE DES PROFESSIONNELS DE LA SANTE

Les médecins et autres professionnels de la santé se déclarent prêts, dans l'éventualité d'un accident nucléaire, à "participer aux soins" et surtout à relayer et expliquer l'information délivrée par les experts. Ils sont à ce titre **demandeurs d'information**. Ceci ressort à l'évidence de tous les sondages effectués ces dernières années. Entre 1986 et 1991, 6 enquêtes portant sur un nombre important de médecins, près de 20 000 au total, menées en France montrent toutes que les médecins réclament une information complémentaire indépendante et réactualisée régulièrement. Ils ont conscience de représenter un relais d'information privilégié dans la mesure où ils jouissent d'une crédibilité incontestée auprès de la population. Dans nos 3 pays, le corps médical jouit à cet égard d'un rôle d'autant plus important qu'il est choisi librement. Ils font confiance aux hospitaliers mais également aux médecins des entreprises nucléaires, qu'ils considèrent comme des confrères spécialisés et compétents. Cette bonne acceptation du médecin du travail dans la formation continue mérite d'être soulignée.

La demande d'information varie évidemment en fonction de la proximité des installations nucléaires, mais la quasi-totalité des médecins souhaite une information complémentaire et spécifique de qualité.

LES MOYENS

Il faut, bien sûr, agir dans le prolongement de la formation acquise en faculté. Dans nos 3 pays, un enseignement de base est dispensé dans toutes les facultés de médecine. Mais il est réel que le contenu et peut-être la qualité de cette formation varient sans doute d'une faculté à l'autre, que cette formation intervient très tôt dans le cursus des études médicales, et que cet enseignement était plus sommaire il y a une quinzaine d'années. De plus, de nombreuses formations complémentaires sont organisées ; en France ainsi qu'en Belgique et en Allemagne, la radiobiologie et la radioprotection sont actuellement enseignées dans le cadre de nombreux certificats de spécialité (radiologie, médecine du travail, médecine d'urgence...).

Les différentes actions entreprises par les sociétés productrices d'électricité peuvent être classées en 3 niveaux complémentaires :

- Niveau européen, comme l'information transfrontalière.
- Niveau national, selon différentes modalités :
 - . Formation médicale continue. Les sociétés électriques n'ont bien entendu aucune initiative propre à prendre dans ce domaine mais elles apportent leur expérience à la demande des organisateurs.
En France, une formation nationale coordonnée par l'UNAFORMEC a été mise en place dans le contexte spécifique de la formation médicale continue.
 - . Information relayée par des périodiques médicaux de grande diffusion.
 - . Envoi systématique de documents, dont toutes les enquêtes montrent qu'ils répondent à l'attente du plus grand nombre de médecins.
- Et surtout au niveau local et régional. En effet, chaque site organise, indépendamment, des contacts et visites en fonction des demandes exprimées localement. Cette décentralisation permet de répondre de manière adaptée aux besoins et de tenir compte des sensibilités locales différentes selon les régions ; elles sont organisées par les collectivités médicales à compétence territoriale.

Ces initiatives locales et régionales représentent :

- + pour la Belgique, durant les 6 dernières années, 52 réunions pour les sites de Doel et Tihange ;
- + pour EDF, entre 1989 et 1991, environ 200 réunions pour l'ensemble des sites ;
- + pour l'Allemagne : Réunions régulières des associations spécialisées sur le plan fédéral et des Länder (environ 200).

A ce titre, des visites d'installations s'avèrent très utiles. Elles permettent non seulement d'appréhender de façon plus concrète la nature des risques mais également et surtout de nouer des relations personnelles qui permettront, ultérieurement, d'établir un réseau de correspondants et de compétences auxquels le praticien saura faire appel.

BILAN - CONCLUSION

Ces moyens sont-ils suffisants et adaptés ? Il est, bien sûr, très difficile de répondre à cette question mais les sondages effectués auprès des médecins permettent néanmoins d'analyser comment cet effort est perçu.

Le contenu de l'information doit, bien sûr, avoir pour objectif de répondre aux interrogations que se pose le médecin. A cet égard, l'urgence radiologique ne ressemble à aucune autre urgence médicale, dans la mesure où aucune prise en charge thérapeutique immédiate n'est attendue de la part du médecin. Or le praticien, face à sa responsabilité de médecin, veut savoir - et cela est légitime - quel serait son rôle précis dans l'éventualité d'une situation accidentelle. Cela se traduit souvent, dans la demande formulée par le médecin, par le désir de disposer de conseils pratiques, de "conduites à tenir" dans différentes circonstances. Et il arrive au praticien d'être "déçu" de ne pas avoir à faire de geste médical salvateur... L'urgence, dans ce domaine particulier de la santé publique est celle de l'information relayée au niveau des patients. Cet aspect de la prise en charge de l'accident est absolument essentiel et pour répondre aux nombreuses questions et inquiétudes des patients, pour conseiller utilement certains groupes particuliers (femmes enceintes, enfants, réticences de certains malades vis-à-vis d'examen radiodiagnostiques...), il doit avoir une "culture" nucléaire suffisante.

Enfin, le praticien doit connaître la spécificité de la surveillance médicale du travail et doit avoir un ordre de grandeur de la dose reçue en irradiation professionnelle et médicale afin de mieux mettre en perspective ces sources d'irradiation par rapport à l'irradiation naturelle...

BIBLIOGRAPHIE

- [1] ARTUS J.C., GRANIER R. - L'information des médecins sur le risque nucléaire et radiologique, C.Méd. 1991, 1386-88.
- [2] JONQUET-MULTON M.E. - Risque nucléaire : Information des médecins dans l'Isère. Thèse Méd., Grenoble, 1991, 109p.
- [3] L'énergie nucléaire vue par les médecins - Résumé d'un rapport du Conseil Scientifique de l'American Medical Association AIEA Bulletin, 1990, 23-30.
- [4] AEN-OCDE - Réunion de travail sur l'information du public sur l'énergie nucléaire, Paris 7-9 mars 1990 - OCDE, 1991, 335p.

THE COMPARATIVE ESTIMATION OF THE RADIATION AND CHEMICAL
CARCINOGENIC RISK INDUCED BY THE ATMOSPHERE CONTAMINATION
DUE TO RELEASES FROM COAL-FIRED POWER PLANTS

V.A.Knizhnikov, V.A.Komleva, N.K.Shandala

Institute of Biophysics, the USSR Ministry
of Public Health, Moscow, USSR

ABSTRACT

In experiments with 1000 white mongrel mice which inhaled benzo(a)pyrene (BP) and fly coal ash for a long time, these agents increased significantly lung tumour incidence, with the latent period shortened. BP is found to be 10-1000 fold more carcinogenic than fly coal ash. The BP inhalation at a sanitary standard level ($0.1 \mu\text{g}/100 \text{ m}^3$ of air) appeared to be equivalent, in murine risk, to the whole-body exposure to a total gamma dose of about 2.5 Sv . The coal ash inhalation in a concentration of $0.05 \text{ mg}/\text{m}^3$ caused the same risk as a dose of 0.05 Sv .

INTRODUCTION

Up to date, relativ contributions of different carcinogenic agents to lung cancers in the population are not quite clear. Therefore, an attempt was made to obtain experimentally a comparative estimation of lung cancer risks due to atmospheric concentrations, actually occurring in population centres, of BP and fly ash released from coal-fired power plants.

MATERIAL AND METHODS

The study involved 1000 white mongrel female mice. Mongrel mice, like man, are known to develop spontaneous lung tumours.

Chronic administration of ash or BP was carried out in special inhalation chambers. In the BP experiment, the mice spent in the chamber 6 hr a day 5 times a week for 3 months; in the coal ash experiment, the chamber residence time was 7 hr a day during 5 months, a total of 48 times. AMADs of coal ash and BP particles were 4.1 and $5.9 \mu\text{m}$, respectively. Experimental animals' lungs retained 25% of fly coal ash particles and 9% of BP dust.

The animals were followed up to their natural death. The dead were subjected to autopsy and post-mortem examination.

In mathematical data processing, the Student parameter criterion was used, and the cumulative probability of lung tumour incidence was estimated by an interval procedure.

RESULTS

The investigational patterns and lung tumour incidence in mice are summarized in Table 1.

Table 1

Lung tumour incidence related to coal ash
and BP intakes by inhalation

Item	Animal group			
	1(control)	2	3	4
1. COAL ASH				
Chamber-air concentration, mg/m ³	0	2.5	5.0	10.0
Retained in the lung, mg/g of tissue *)	0	1.0	2.0	4.0
Animals with lung tumours, % **)	28	37	61	78 ***)
Animals with ash-induced tumours, %	0	9	33	50
2. BENZO(A)PYRENE				
Chamber-air concentration, µg/m ³	0	0.2	6.3	78.0
Retained in the lung, µg/g of tissue	0	0.0025	0.8	9.0
Animals with lung tumours, %	14	23	37	40 ***)
Animals with BP-induced tumours, %	0	9	13	26

Notes: *) - The ash or BP dose (amount) retained in the lung was calculated by AMADs of respective aerosols.

***) - Using the interval procedure.

***) - P < 0.01 as compared with control.

The evidence from Table 1 suggests a positive carcinogenic effect of BP and fly coal ash in the study.

Table 2 gives average latent periods (ALPs) of tumours, time between the onset of administration and the first tumour appearance, and ALPs for the first 25% and 50% of murine tumours following the coal ash inhalation.

The data from Table 2 show a carcinogenic capacity of fly coal ash, thus supporting the results from Table 1. It is noteworthy that coal ash is considerably less carcinogenic than BP - by one to three orders for different concentrations. The dose-response curves for these agents differ: close to linearity for ash and far from it for BP.

Table 2

Average latent periods (ALP) of lung tumours
by coal ash concentrations inhaled

Item	Animal group			
	1(control)	2	3	4
	Ash concentration, mg/m ³			
	0	2.5	5.0	10.0
ALP	615±45	545±47	523±40	457±59 (**)
First tumour appearance	488	217	283	221
ALP 25%	490±3	402±47	349±47 (**)	228±9 (*)
ALP 50%	504±10	458±49	409±36 (**)	280±30 (*)

Notes: *) - P < 0.01 as compared with control;

***) - P < 0.05 as compared with control.

Mathematical data processing of both experiments gave the following dose-response equations:

$$\text{for coal ash} \quad Y = 5.2X + 28 \quad (1)$$

$$\text{for BP} \quad Y = 16.4 (Z)^{0.19}, \quad (2)$$

where Y is the percentage of animals with lung tumours;

X is the coal ash dose (mg/g of lung tissue);

Z is the BP dose (µg/g of lung tissue).

DISCUSSION

The findings from Table 1 and 2 should be discussed, above all, with respect to the question: if coal ash exhibits a carcinogenic capacity, why then this capacity has not been revealed in other similar studies, e.g. in a detailed one by S.Persson et al [1]?

An analysis of radionuclides, BP and some metals contained in ash showed that the carcinogenic effect of coal ash might result from chromium, nickel, cadmium, arsenic and other metals. Such metals as chromium, beryllium, etc., accumulated in the lung amounted to 10E17 molecules and more [2]. As for the latter part of the question, in the above mentioned [1] and other studies, BP and coal ash were administered to animals intratracheally in suspension, rather

than by natural inhalation. Very soon, the agents administered were rejected. In our study, the agent contact with the lung tissue was much longer, without any serious disturbance of the lung physiology.

Another issue of importance is a comparative risk estimation for BP and ash.

Does a low, as compared with BP, carcinogenic activity of coal ash mean no danger? Apparently not, given millions of tons annually released from solid fuel plants into the atmosphere. Moreover, a direct carcinogenic effect of ash was observed in our experiments at air concentrations very close to those actually encountered in the atmosphere. It should also be noted that the carcinogenic effect of ash, like other carcinogenes, e.g. BP, may have no threshold.

Table 1, equations (1), (2) and dose-response relationships known for ionizing radiation permit rough estimates of the radiobiological carcinogenicity equivalent for BP and fly coal ash. Similar death risks from induced cancer are caused by the whole-body exposure to a total gamma dose of 0.054 Sv and by the fly coal ash intake at a concentration of 0.05 mg/m³. For a BP concentration of 0.1 µg/100 m³, the radiobiological carcinogenicity equivalent is 1.98 Sv.

CONCLUSION

Earlier, the authors were the first to demonstrate experimentally the ability of fly coal ash inhaled with the air to induce lung cancer [2, 3]. It is also for the first time that the dose-carcinogenic response relationship has been studied for the coal ash and BP intake by inhalation.

The USSR current standards for coal ash and BP concentrations in the air do not prevent the population from a substantially higher risk than that caused by exposure to radiation within radiation protection limits.

REFERENCES

1. Persson, S., Ahlberg, M., Berghem, L. et al., 1988. Long-Term Carcinogenicity Study in Syrian Golden Hamster of Particulate Emissions From Coal- and Oil-Fired Power Plants, Environmental Health Perspectives, 77, pp.109-120.
2. Knizhnikov, V.A., Novikova, N.K., Grozovskaya V.A. et al., 1987. On blastomogenic effectiveness of the combined action of fly coal ash components, Gigiyena i Sanitariya, 3, pp.10-13.
3. Knizhnikov, V.A., Grozovskaya, V.A., Litvinov, N.N. et al., 1979. Malignant lung tumours in mice due to inhalation of schistous ash, 3,4-benzo(a)pyrene and polonium-210. In: Hygienic problems of radiation and chemical carcinogenesis, Moscow, pp.74-79.

METHODS AND PRINCIPLES FOR MAKING PRIORITIES IN RADIATION PROTECTION

J.O. Snihs

Swedish Radiation Protection Institute, Stockholm, Sweden

ABSTRACT

In making priorities one has to distinguish between the problems and the methods to solve them. They are both ranked on basis of aspects relevant for radiation protection and given different relative weight. The discussions in Sweden have concluded that the most important tasks in priority order are to prevent acute deaths, preclude stochastic effects in large populations, consider radiation problems related to high social and economical values and preclude stochastic effects in particularly exposed individuals. This leads to 8 areas of special concern.

INTRODUCTION

A first choice of priorities is found in the relative weight of questions on radiation protection as compared with other problems in the society. This choice is made on the political level on the basis of proposals presented by the competent authority. Factors involved are the available resources, the relative cost effectiveness of activities in various areas of concern and the political significance of the problems in a more wide political framework.

A recent modifying factor in the choice of priorities is the increasing interest by politicians, authorities and scientists to get a better balance and similarities in the judgement and handling of risks from various kind of environmental pollutants. These may be e.g. radioactive and non-radioactive releases from industries and from waste disposal facilities. Two recent symposia discuss these problems (1,2).

In the area of radiation protection there is also an ambition to balance the efforts in reducing radiation doses in order to make the radiation protection optimized. That means that improvements in protection should be reasonable in comparison with other efforts made in society to reduce risks. This is achieved by using economical valuation of risks and relating these to protection costs.

PRINCIPAL METHOD FOR CHOICE OF PRIORITIES

At the authority level the decision on priorities is reflected in the budgetary process. This is made by choosing priorities of the marginal changes in the existing program i.e. using the so called incrementalistic approach in the decision making (3,4) or by using a more rigorous approach by questioning the whole programme on radiation protection and choosing priorities more thoroughly. Both methods have their benefits and drawbacks (5).

The first method is normally less cumbersome and therefore more often used. The second method is by definition more time consuming and needs more manpower. How it can be accomplished is described below on the basis of Swedish experience.

The activity of the authority is characterized by its programmes, working methods, organisation and resources. The choice of priorities is made on the problems to be solved i.e. the programmes, and on the working methods. The degree of priority of a problem decides its timetable and resources to be allocated. The degree of priority of various working methods decides inter alia the efficiency and profile of the authority. It is necessary before making priorities to structure the problems (and working methods) in a systematic way to make them comparable.

The various possible working methods are defined as e.g. international work, inspections, own measurements and control, check others' measurements, standardize, give lectures, give criteria, etc.

The basis for forming an estimate of the relative importance of the various problems (i) is a set of factors (aspects) (j), which are more or less important from the radiation point of view and for which we need to assess their relevance for each problem, (i).

Examples of these factors are political decisions, international decisions, requirements by the public, public concern, legal requirements, controllability, benefit of the practice where the problem occurs, cost-effectiveness of an action, collective doses, individual doses, risk of accidents, prognosis of development etc.

The importance of these factors (aspects) for each of the various problems gives a basis for choice of priorities. It can be found in three steps.

The first step means a ranking of the problems (i) with regard to the factors (j), one by one. This can be made by comparison of pairs of (i) in a matrix in such a way that the problems (i) will be ranked in order of importance for each factor (j). There is therefore one matrix for each (j). The ranking is made by answering the question: how important is factor (j) for a given problem (i) in the judgement of the overall importance of the problem, assuming that something can be made reasonably to solve/decrease/control the problem in respect to aspect (j). The ranking of problems in each matrix should reflect the relative importance of each aspect (j). In all matrices the condition of symmetry must be fulfilled i.e. if $a > b$ and $b > c$ then also $a > c$. This procedure yields a weighting factor w_{ij} for importance.

The second step means a ranking of the factors (j) irrespective of problem but just considering the overriding objectives of the authority and the general valuations in the society having in mind the actual state of conditions of the

radiation protection in the country. The ranking can also here be made in a matrix by a pair-ranking method, with condition of symmetry. The basis for judgements should in principle be made by interviews of various groups in the society. This yields a weighting factor q_j .

The two ranking procedures lead to a set of weighting factors of the problems (i) for each aspect (j). The third step is to multiply each factor w_{ij} with corresponding factor q_j and add all these products for each (i). The numerical value of the sum $\sum_j q_j w_{ij}$ indicates the relative priority of each programme. The reliability of the method is checked by a sensitivity analysis by having several people making the same analysis independently.

The choice of priorities for the working methods can in principle be made similarly. The factors (aspects) may be efficiency, cost, speed, competence, development, attracting and keeping personnel, good reliability, etc.

PRACTICAL RESULTS

In the discussions of priorities for the next 3-year radiation protection programme of the Swedish Radiation Protection Institute the presented methods and ideas were leading the thoughts even though we did not proceed along the mathematical formalism described above. It was concluded inter alia that the most important tasks of the Institute are in priority order the following

1. to prevent acute deaths and other serious damage caused by radiation
2. to preclude or decrease the stochastic effects of radiation in large populations
3. to pay attention to radiation protection problems related to conditions in society with high social and economical values
4. to further preclude or decrease the stochastic effects of radiation in particularly exposed individuals.

Using these bases of judgment in combination with some others, eight programmes (problems) were identified as those of highest priority. They are given below with special explanation in Fig.1 why they are justified. Their relative position is not in order of priority.

1. Radon in houses
2. Sun radiation
3. X-ray examinations of patients
4. Emergency preparedness for nuclear accidents in Sweden or abroad
5. Data screens
6. Strong sealed radioactive sources and large accelerators
7. Normal operation of nuclear power
8. Radioactive waste of nuclear power.

Fig. 1

Qualification/Programme	1	2	3	4	5	6	7	8
Number of cancer deaths per year prevented by protection effort	>100	>100	-	>10 ³	2)	-	-	-
Number of Swedes running a risk >1% to die in cancer caused by radiation	>10 ⁶	~10 ⁶	>10 ³	1)	-	-	>10 ³	-
The protection efforts are cost-effective.								
Number of lives saveable for less than 0.2 M US dollars per life	>10	>100	>10	-	-	-	-	-
The radiation problems are connected to high social and economical values	yes	yes	-	yes	yes	-	yes	yes
There is a risk of acute deaths	-	-	-	yes	-	yes	-	-
The problem is increasing.								
A protection effort now is more efficient than later	-	yes	-	-	yes	-	-	yes
Need of good control	-	-	-	-	-	yes	yes	-

Notes. 1. Means unnecessary deaths
 2. In total after a very serious accident

CONCLUSION

The discussion on priorities has been well received at the political level since it has been possible for board members and ministry officials to understand the main arguments behind the priorities suggested. In times of budget cuts it helps the politicians to get the best value for the money spent.

REFERENCES

1. Management of Risk from Genetoxic Substances in the Environment. Proceedings of a Symposium and Workshop, 3-6 Oct. 1988, Stockholm
2. Environmental Consequences of Hazardous Waste Disposal. Proceedings of a Symposium, 27-31 May, 1991, Stockholm
3. Lindblom, C.E. 1959: The Science of "Muddling through". Public Administration Review Vol. 19 p. 79-88
4. Lindblom, C.E. 1979: Still muddling, not yet through. Public Administration Review Vol. 41 p. 517-26.
5. Bengtsson, G. 1988: Integration of economic and other aspects in decisions to regulate genetoxic substances. Proceedings of a Symposium and Workshop, 3-6 Oct. 1988, Stockholm (see ref. 1 above)

NEW SETTING-UP OF THE CRITERION OF ACCEPTABILITY OF RISK IN
RADIOPROTECTION SECTOR

L. Failla

I.N.P.R.A.T.

(National Institute for Risk Prevention in Technological
Activities)

ABSTRACT

The method presently used for choosing the values of "acceptability" of the risk of damage from i.r. is based on the comparison with other risks in human life, it divides the persons exposed to the risk into groups and establishes for each of them the values of doses considered "acceptable". Taking into account that the damage involves the single person, the risk-benefit relation is evaluated on him, putting aside the distinction in groups and the general method of comparison.

The relation $B > R > 0$ where B =benefits and R =risks. Applied to the single person enables us to identify the "acceptable" doses for him, through an appropriate selection of B and R .

INTRODUCTION

As we know, ionising radiations (i.r.) can cause damages to the man who absorbs them. The probability of damage becomes lower whenever the absorbed dose of i.r. decreases; but it is not possible to establish a threshold under which this probability is zero. It is assumed as a working hypothesis in order to establish the fundamental criteria of radioprotection for those doses which produce "stochastic" effects. This hypothesis derives from the proportionality between the risk (probability) of damage and the absorbed dose, represented by a straight line which passes through the origin of the cartesian axis.

A large literature on this topic and mainly the ICRP itself, have examined and are examining the issue resulting from this lack of threshold; this involves the need to establish a value of "acceptability" of the risk which corresponds to a certain value of dose in order to make the use of i.r. possible. Therefore, it is necessary to choose and eventually indicate and recommend such value of "acceptability" based on appropriate methods or criteria to establish.

At this stage, this issue shifts obviously from the scientific field towards the moral, political and social ones.

DISCUSSION

The ICRP No.9 (sept.1965), but also others of its publications, states the principle "that all doses be kept as low as is readily achievable" but it also adds "economic and social consideration being taken into account", briefly indicated as ALARA. Apart from this, it is pointed out that this principle states the opportunity to keep doses as low as possible in order to expose people concerned to the minimum risk which is considered "acceptable", although the introduction in the second part: "economic.." makes its application more flexible.

The criteria and methods used by the ICRP to recommend the

values of "acceptability" are inspired by this principle and are based on the system of comparison with the risks the man runs during every-day life. Based on these criteria and on the above principle (ALARA), the ICRP has identified the maximum values for those doses which cause a risk considered "acceptable" by mankind. These values are divided into three groups of exposed people: 1) workers; 2) people exposed for medical reasons; and 3) population. Therefore they do not take into account the single person but they stick to general considerations. Moreover, they do not make a distinction between those people who are the object of the risks and those who get the benefits.

But the damages we are discussing have their effects on the single person exposed to i.r., causing considerable pain to the individual himself and to his relatives.

The proposed method for choosing the criteria of acceptability differs from the present method used, which has been explained earlier, as it examines the single individual exposed to i.r. developing a risk-benefit analysis which is personalized even though it utilizes, as we will see later, objective and general parameters. The above method consists of moving the risk-benefit analysis from a general interest for the society to the specific one for the single individual. The value of "acceptable" risk and, therefore, the maximum dose accepted for the stochastic damages is chosen on the basis of this individual analysis. According to the above, the objects of the risks and benefits respectively can be inserted automatically, being the individual the object of this relation, while the proposed three categories of the ICRP No.60 are no longer valid.

Let us indicate with "R" the risk of damage resulting from the absorption of i.r. and with "B" the benefits originated by the activity involving such risk; the "acceptable" dose for each single individual should be: $B-R > 0$ (1).

The value of risk (probability) of damage to the single person, according to the absorbed dose, can be obtained from the straight line, used in the working hypothesis explained above, which indicates the proportionality between the dose and the risk. Therefore this value can easily be quantified for each person on the basis of the received dose, by using the above considerations; it will be possible to identify the value of maximum dose for each single person in order to make the risk-benefit relation more advantageous to him, hence to consider such value "acceptable".

The benefits deriving to man from the use of i.r. are numerous and of a different kind. They can, however, be summarized in two main benefits:

A) reduction, as a result of the use of i.r., of the risk of damage due to those activities differing from the ones which expose man to i.r. (B_d); if we know the type of activity exposing a person to i.r., we can evaluate this reduction (B_d), by considering those tables and statistics which are used for insurance purposes and are indicated by the competent national and international organizations. B) The improvement of welfare (living conditions) of the exposed person (B_m). The fundamental elements on which man physical welfare is based can be divided into the following two groups: $B_{m,1}$, those elements involving man directly; and $B_{m,2}$, those ele-

ments which act through the social organization. Hence we will have the relation: $B_m = B_{m,1} + B_{m,2}$. For the first elements ($B_{m,1}$) a further classification can be made into the following groups that are the fundamental elements for the human life: $B_{m,1,1}$: food; $B_{m,1,2}$: clothes; $B_{m,1,3}$: house; $B_{m,1,4}$: Health.

The quantitative choice of the various $B_{m,1}$ depends on the different individual and social situations and each country should establish these values giving them a "weight" on the basis of particular social and environmental circumstances. We will have: $B_{m,1} = B_{m,1,1} + B_{m,1,2} + B_{m,1,3} + B_{m,1,4}$.

For the second group ($B_{m,2}$: the social organization) to improve the conditions in the above sector, utilizes the elements which can be summarized as follows:

$B_{m,2,1}$: goods production; $B_{m,2,2}$: goods exchange;
 $B_{m,2,3}$: health.

The above sectors are a synthesis of various activities. Like for $B_{m,1}$ also for $B_{m,2}$ we have to give a "weight" to each sector. Hence we will have: $B_{m,2} = B_{m,2,1} + B_{m,2,2} + B_{m,2,3}$.

Once $B_{m,1}$ and $B_{m,2}$ are evaluated in this particular situation, we will be able to calculate B_m keeping in mind that the "weights" to be given to $B_{m,1}$ and $B_{m,2}$ have a minimum value = 0 and a maximum value reflecting a particular environmental condition.

The choice of the above elements ($B_{m,1}$ and $B_{m,2}$) is only indicative; it can be substituted and extended. Our purpose is to present a working method necessary to introduce the proposed principle: "of the application of the risk-benefit relation to the single individual exposed to i.r."

CONCLUSIONS

We have already shown how to evaluate B_d ; with the above, we can evaluate B_m . Therefore we have $B = B_d + B_m$ (2) replacing on (1) we have $(B_d + B_m) - R > 0$.

The evaluation of R can be easily made using the hypothesis of the straight line which shows the relationship between the absorbed dose and the probability of damage. This will give the possibility to choose the maximum value of dose of i.r. considered "acceptable" for the single individual exposed. Keeping unchanged the relation $B - R > 0$ (1). However, if we take into account the ALARA principle, we will notice that the relation (1) indicates those values of R which are not to exceed but, if possible, they must be further reduced.

REFERENCES

- ICRP-Publication No.9: Recommendations of the ICRP (Adopted September 17, 1965).
- ICRP-Publication No.22: Implications of Commission Recommendations that Doses be kept as Low as Readily Achievable. Adopted: April 1973, Pergamon Press.

- ICRP-Publication No.26; Recommendations of the ICRP. Adopted January 17, 1977, Pergamon Press.
- L. Failla-Comparison between Worker-Deaths in Modern Industries and in Nuclear activities-Presented in the IV International Congress of IRPA. Paris, April 1977-Comitato Naz. Energia Nucleare RT/PROT (77) 15.
- L. Failla-"Acceptable Risk: a New Concept of risk"-(Presented in the Istanbul Congress, May 1978-ILO)-Comitato Naz. Energia Nucleare-RT/PROT (78) 18.
- L. Failla-"The risk acceptability"-Proceedings GFS Sommer Symposium '79-Juni 1979-Gesamthochschule Wuppertal (Germany).
- L. Failla-Statistics and risk Philosophy in human activities-Proceedings the Regional Congress of International Radiation Protection Association-Avignon (France), October 1982.
- ICRP-Publication 37 (Annals of the ICRP Vol.10 No.2/3, 1983). Cost benefit Analysis in the optimization of radiation protection-Adopted by the commission in June 1982-Pergamon Press.
- L. Failla-La filosofia del rischio. Security, dicembre 1985.
- L. Failla-Radiazioni Ionizzanti: Rischi-benefici o costi-benefici? Considerazioni Etiche-Medicina e Morale-3, 1989- Roma (Italy).
- ICRP-Publication 60 (Annals of the ICRP Vol.21 No.1-3, 1990- Recommendations of the International Commission on Radiological protection-Adopted by the Commission in November 1990, Pergamon Press.

L'INFORMATION DE LA POPULATION DE L'ISERE EN MATIERE DE RISQUES
TECHNOLOGIQUES MAJEURS ET PLUS PARTICULIEREMENT DE RISQUE NUCLEAIRE

H. de CHOUDENS, Adjoint au Directeur du Centre d'Etudes Nucléaires de
Grenoble - Commissariat à l'Energie Atomique - FRANCE

POPULATION INFORMATION ON MAJOR TECHNOLOGICAL RISKS AND SPECIALLY ON
NUCLEAR RISK.

Following Tchernobyl accident which has revealed in France a strong need for information on technological risks among population and a lack in its organisation, the Mayor of Grenoble City who was also at this time, Environment Minister in French Government had initiated in Isère Région an important opération of consideration of actions which has to be undertaken to correct these lacks.

Among ten actions retained one of them was the creation of an Association for Information of the public for Prevention of major risks.

This Association has first initiated a consultation on the perception by the population of the different major risks (Industrial and Natural) in view of the results of this consultation, Medical Professions were the first concerned and a publication "Medecine and Nuclear risk" has been elaborated and distributed to all doctors of the Region.

A Memento on Nuclear risk has then been written and largely distributed in the region, specially in the medias.

A booklet on Nuclear risk and behavior in case of Nuclear accident has then been realised and distributed to all people around Electronuclear Reactors of the Region and to children in the schools. In complement, public meetings have been organised in these sectors to inform and discuss with the population.

INTRODUCTION :

Entre autres réactions pleines d'enseignements, l'accident de Tchernobyl a mis à jour en France un besoin pressant d'information de la population dans le domaine des risques majeurs qu'ils soient industriels (risque chimique, risque nucléaire...) ou qu'ils soient naturels (tremblement de terre, éruptions volcaniques, glissements de terrains...).

Parallèlement, il est apparu que tous les organismes officiels capables de fournir en cas de crise les informations nécessaires ainsi que dans une certaine mesure, les médias chargés de diffuser l'information, étaient finalement mal préparés à jouer ce rôle.

Dans le Département de l'Isère, le Maire de Grenoble qui était alors Ministre de l'Environnement dans le Gouvernement Français a donc lancé durant l'été 1986 une grande opération de réflexion sur les moyens de prévention et de gestion des Risques Technologiques et Naturels Majeurs. Au cours de cette opération, entre autres, une commission spécialisée s'était penchée sur les problèmes d'information des populations, avant, pendant et après une catastrophe.

Dix actions prioritaires avaient été retenues dans le rapport final rédigé à la fin de l'opération. Parmi celles-ci, l'une préconisait la création au niveau départemental d'une structure permanente chargée d'organiser et de diffuser l'information. Ainsi fut créée l'Association d'Information pour la Prévention des Risques Majeurs (AIPRM) regroupant les organismes publics, les collectivités locales, les industriels, les scientifiques, les associations de défense de l'environnement, les syndicats. L'Association est présidée par une journaliste, Noële ROY.

LA PERCEPTION DES RISQUES PAR LA POPULATION

S'agissant d'informer un public aussi hétérogène qu'une population, il est apparu nécessaire à l'Association de déterminer quels étaient les comportements de celle-ci en matière de risques majeurs et quels étaient les relais qui possédaient le plus de crédibilité auprès du public et pourraient être utilisés. Une enquête auprès de la population de l'Isère fut donc confiée à une équipe de l'Université des Sciences Sociales de Grenoble dirigée par un de ses professeurs Anne LALO.

Les résultats en furent, sur certains points surprenants. Ainsi dans un département très nucléarisé tel que l'Isère (deux sites de Centrales Electronucléaires dont un surgénérateur, deux centres de recherche avec deux réacteurs, une usine de fabrication de combustibles nucléaires), l'accident grave dans une installation nucléaire n'arrive qu'en sixième position dans les préoccupations de la population avec 20 % de personnes inquiètes (le souci majeur du public est le risque d'accident de la route, voir Fig.1).

Quant aux personnes ou organismes à qui le public fait confiance pour avoir des informations, ce sont les gens ou organismes considérés comme indépendants des enjeux économiques et politiques qui sont les plus crédibles ; à l'autre extrémité, pouvoirs publics, élus, journalistes, industriels sont peu, voire très peu crédibles (fig.2).

INFORMATION DES PROFESSIONS MEDICALES

Les résultats de l'enquête citée au précédent paragraphe montrent que les médecins sont parmi les catégories considérées par la population, comme les plus crédibles pour donner des informations sur les risques. D'autre part, en cas d'accident radiologique, les personnes inquiètes de ses conséquences pour leur santé, s'adressent tout naturellement à leur médecin pour être informées. En France, l'accident de TCHERNOBYL a bien mis en évidence ce recours aux médecins des personnes les plus anxieuses sur les conséquences de retombées radioactives. Corrélativement, les médecins se sont trouvés tout à fait démunis pour répondre aux interrogations du public et ont manifesté par la suite une forte demande de formation et d'information sur les problèmes des risques radiologiques et sur leur rôle vis à vis du public lors d'un accident nucléaire majeur.

La Faculté de Médecine de Grenoble, sous l'impulsion de son doyen le Professeur G. VROUSOS et avec le soutien de l'Association d'Information pour la Prévention des Risques Majeurs a donc très rapidement entrepris la réalisation d'une plaquette "Médecins et Risques Nucléaires" donnant la conduite pratique pour les médecins en cas d'accident nucléaire (fig.3).

Cette brochure (fig4) donne en particulier sous forme de fiche style "check list" les conduites à tenir en présence de différentes situations : personne irradiée et/ou contaminée, blessée et contaminée...

Cette plaquette a donc été distribuée à tous les médecins de l'Isère en 1988. Deux ans après sa publication en 1990 pour essayer de déterminer son efficacité, une étude d'impact a été réalisée par un cabinet spécialisé auprès des médecins qui en avaient été destinataires. Les résultats ont montré l'intérêt soulevé par une telle publication. En effet, 61 % des médecins interrogés se souviennent avoir reçu la plaquette et parmi ceux-ci 80 % l'ont conservée dont 65 % après l'avoir lue (pour les spécialistes en communication, ces résultats à deux ans, pour ce type de support, sont à considérer comme très bons).

Après sa diffusion dans l'Isère, une demande s'est manifestée de la part d'autres départements français ce qui conduit à une diffusion nationale et à un tirage important (à ce jour à 50.000 exemplaires). L'initiative de distribuer une telle brochure aux médecins a été soulignée comme excellent par les inspecteurs de l'AIEA venu faire une évaluation des mesures prévues pour faire face à un accident autour de la Centrale Electronucléaire de St ALBAN, - St MAURICE L'EXIL, en Isère. L'AIEA a d'ailleurs demandé l'autorisation de la traduire en anglais. Par ailleurs cette plaquette a reçu en 1988 le Prix de la Société Française d'Energie Nucléaire récompensant une action remarquable effectuée par l'information du public.

L'action d'information du monde médical n'est pas considérée comme terminée par la distribution de cette plaquette. En effet, l'étude d'impact indiquée ci-dessus a aussi montré que 89 % des médecins désiraient que des initiatives continuent à être prises pour leur information dont la rédaction d'une nouvelle brochure leur donnant des renseignements complémentaires.

Prenant acte de ce besoin, de nouvelles actions sont donc d'ores et déjà lancées :

- . Actions de formation post universitaire sur le risque radiologique.
- . Edition d'une version améliorée et complétée de la plaquette
- . Publication d'une revue périodique : "Médecins et Rayonnements Ionisants".

LES MEDIAS, LES ELUS, LES "DECIDEURS":

A l'occasion d'un incident nucléaire, les personnes chargées de recevoir puis retransmettre l'information : journalistes, responsables des pouvoirs publics, élus, se trouvent confrontés à une communication utilisant des notions et un vocabulaire loin de leur être familier. Pour leur fournir un document auquel ils pourraient se référer facilement, s'ils éprouvent la nécessité de se remémorer la signification de certains éléments qui leurs sont transmis, un "Mémento du Risque Nucléaire" a été rédigé et diffusé (Fig 5 - Mémento du Risque Nucléaire).

Au-delà de la cible concernée par ce mémento, celui-ci a suscité l'intérêt des responsables de la Sécurité Radiologique de quelques organismes qui ont obligation de fournir à leurs travailleurs et particulièrement aux travailleurs occasionnels ou intérimaires, une information sur le risque radiologique et les moyens de s'en protéger. Ainsi à Grenoble, l'Institut Laue Langevin, organisme européen de recherche exploitant un réacteur à Haut Flux de Neutrons, et à l'échelon national Electricité de France, utilisent ce mémento pour certaines catégories de leurs personnels. A ce jour, le tirage de cet ouvrage s'élève à 15000 exemplaires. Toute personne du public intéressée par les problèmes de

risques radiologiques mais peu familier avec ce domaine, peut d'ailleurs utiliser un tel document qui cherche à présenter de façon simple et compréhensible par tous les éléments de Radioprotection.

L'EDUCATION NATIONALE

Les enfants et adolescents constituent une catégorie du public qu'il est primordial de sensibiliser aux problèmes des risques majeurs et d'éduquer quant aux conduites à tenir en cas d'accident. Ce sont en effet les adultes de demain et qui plus est, un excellent relai de l'information vis à vis de leurs parents. L'Education Nationale est pour ce public, l'intermédiaire le plus efficace et quasiment obligé pour faire passer les messages. L'Association a donc entrepris un travail en profondeur avec un Groupe de Travail formé d'enseignants. Ce groupe s'est attaché en premier lieu à définir et organiser sous forme de stages une formation des enseignants qui seront ensuite amenés à intégrer dans leurs enseignement une partie consacrée aux risques et aux manières de s'en protéger. En second lieu, les outils pédagogiques nécessaires ont été élaborés sous forme d'une mallette pédagogique contenant les éléments nécessaires au professeur pour préparer ses cours et en présenter les éléments à ses élèves. Cette mallette concerne actuellement le risque chimique et il est bien entendu de faire de même pour le risque nucléaire.

LA POPULATION

Cible ultime de l'information, des actions directes ont été menées à son égard.

Tout d'abord compte tenu de l'obligation faite aux pouvoirs publics et aux exploitants d'Installations Nucléaires, d'informer la population des communes avoisinantes, l'Association a apporté son concours aux exploitants des Centrales Electronucléaires de l'Isère pour réaliser une plaquette qui a donc été diffusée à tous les foyers concernés et aux enfants des écoles (Fig.6). D'autre part, dans le cadre d'une grande campagne d'information étalée sur plusieurs mois et comportant, en plus de conférences diverses, d'informations à la radio et à la télévision et des réunions publiques de discussions dans les zones entourant les contrôles, une brochure traitant de tous les risques technologiques et industriels dont bien entendu le nucléaire a été rédigée et mise en vente (pour une somme modique) chez les distributeurs habituels de journaux.

CONCLUSIONS

L'information du public qui ne peut être dissociée d'une formation nécessite un effort soutenu de longue haleine. Dans le passé, elle a trop souvent été négligée ou n'a fait l'objet que de campagnes utilisant parfois de gros moyens mais de durées brèves, style "coup de poing". Les résultats ont montré que leur impact était souvent faible et toujours éphémère. Jusqu'à un passé récent et dans une certaine mesure, maintenant encore, la population ignore souvent comment elle serait avertie d'un accident et la conduite qu'elle aurait à tenir. SEVESO, BHOPAL puis TCHERNOBYL ont en France, mis en lumière, ces besoins.

Au niveau des Pouvoirs Publics et des Industriels, de gros efforts ont été consentis pour améliorer la situation en matière d'information. Dans l'Isère, la création de l'Association d'Information pour la Prévention des Risques Majeurs (AIPRM) soutenue matériellement par le Conseil Général du Département a été un élément important de cet effort. En près de quatre ans, après une phase d'organisation, l'AIPRM peut mettre à son actif des réalisations qui ont rencontré un excellent accueil auprès de la population et qui, point le plus important, s'inscrivent dans un programme continu qui en fait n'est est qu'à son début. L'action de l'AIPRM s'inscrit donc dans le long terme.

BIBLIOGRAPHIE

- 1 - A. LALO - Ph du Jardin
Enquête sur la perception des risques majeurs en Isère.
Association d'Information pour la Prévention des Risques Majeurs, 9 Rue
Lesdiguières - 38000 GRENOBLE - FRANCE
- 2 - Faculté de Médecine de Grenoble - Conseil Général - Préfecture :
"Médecine et Risque Nucléaire " Conduite pratique en cas d'accident
Docteur GALLIN-MARTEL - Centrales de Creys Malville, BP 63 - 38510 MORESTEL.
Docteur H. KOLODIE - Service de Radiothérapie - CHRUG - BP 217 X - 38042
GRENOBLE CEDEX
- 3 - H. de CHOUDENS "Mémento du Risque Nucléaire"
Association d'Information pour la Prévention des Risques Majeurs, 9 Rue
Lesdiguières - 38000 GRENOBLE
- 4 - E O F (Centrales de Creys-Malville - du Bugey - de St ALBAN - de St
Maurice l'Exil) :
Energie Nucléaire et Sécurité des Populations
- 5 - Association d'Information pour la Prévention des Risques Majeurs
Risques Majeurs en Isère

On éprouve parfois de l'inquiétude pour soi-même ou pour ses proches. Pouvez-vous dire quels sont les risques qui vous inquiètent le plus, personnellement ?

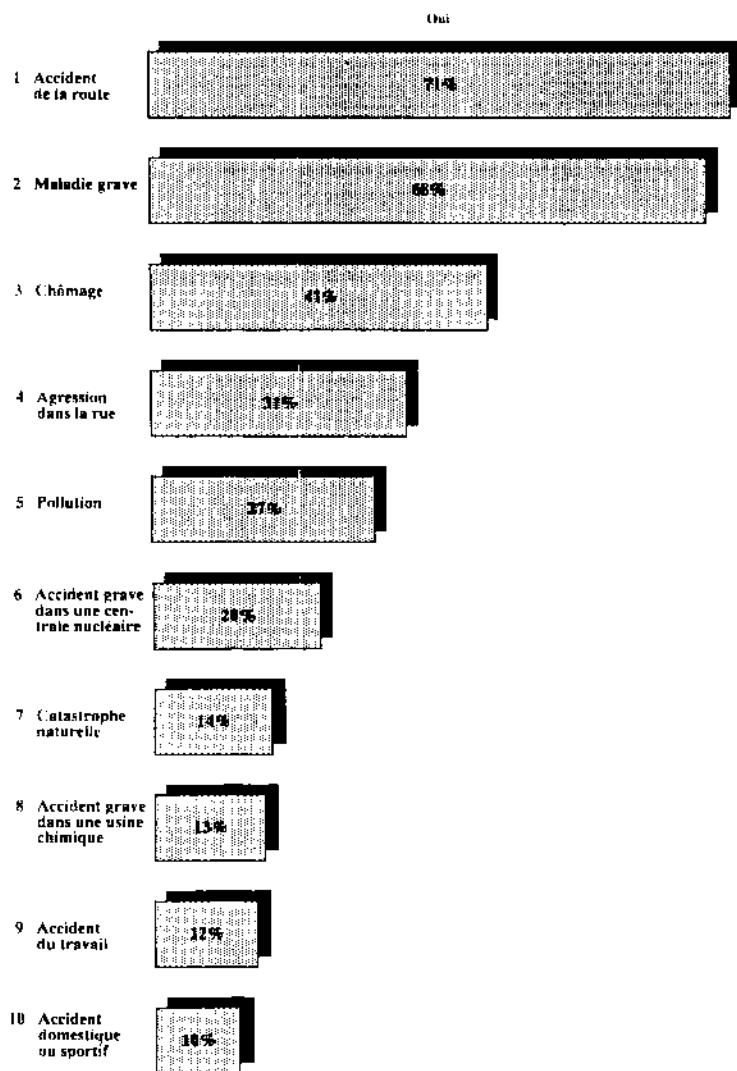

Fig. 1 : Les problèmes qui préoccupent le public

Pour vous donner des informations sur les risques d'accidents industriels graves, faites-vous confiance aux personnes suivantes ?

Synthèse des résultats

1 Aux pompiers 74%	8 Aux CHSCT des entreprises 41%	14 Aux syndicats des usines 24%
2 Aux scientifiques 60%	9 Aux organismes privés spécialisés 37%	15 Au préfet 24%
3 Aux associations de protection de l'environnement 58%	10 Aux ingénieurs du ministère de l'Environnement 34%	16 A la police 23%
4 Aux médecins 55%	11 Aux ouvriers des usines 30%	17 Aux enseignants 20%
5 A la Croix Rouge 53%	12 Aux ingénieurs du ministère de l'Industrie 29%	18 Aux journalistes 19%
6 Aux écologistes 50%	13 Aux pharmaciens 27%	19 A l'armée 18%
7 Aux associations de consommateurs 49%		20 Aux élus de votre région 18%
		21 Aux industriels eux-mêmes 14%

Fig 2 : Qui est le plus crédible pour donner des informations ?

MÉDECINS ET RISQUE NUCLÉAIRE

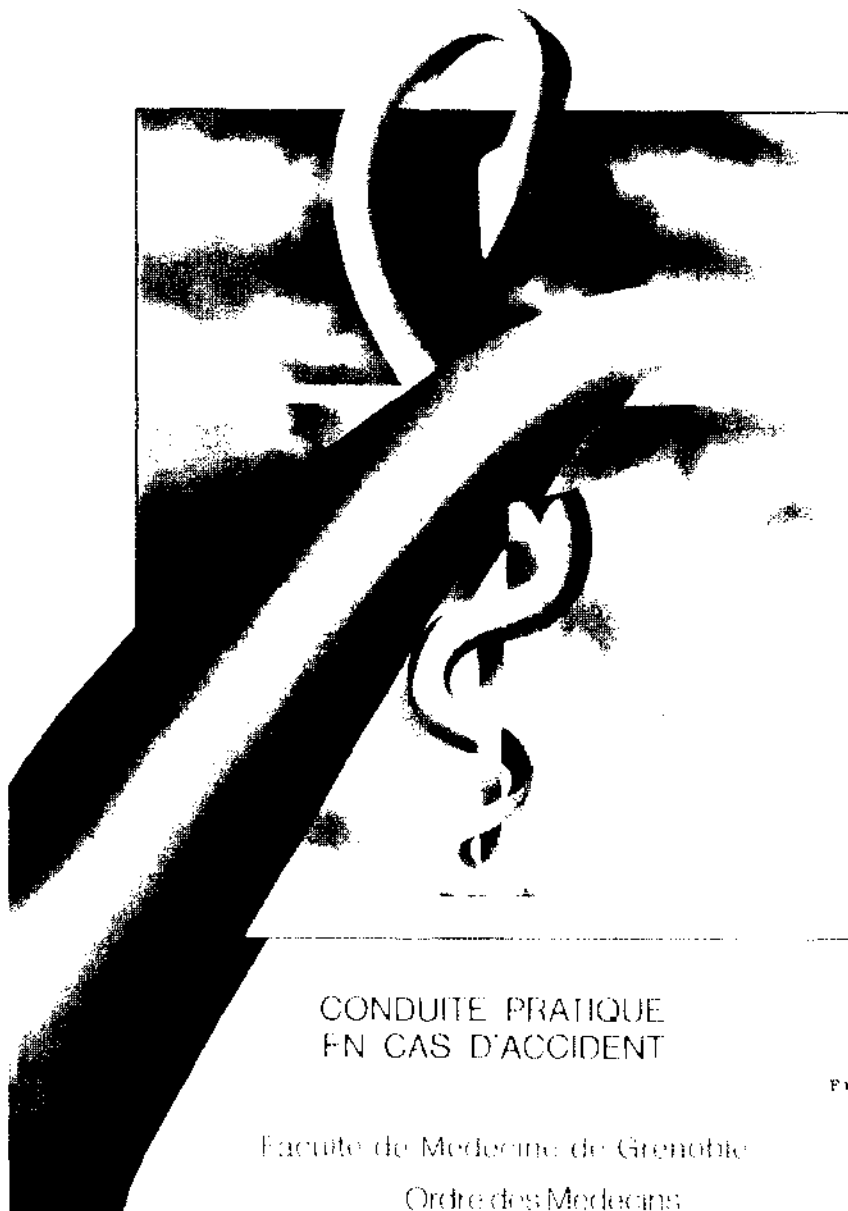

CONDUITE PRATIQUE
EN CAS D'ACCIDENT

Figure 1

Faculté de Médecine de Grenoble
Ordre des Médecins

En cas d'association à une pathologie traumatique, on appliquera d'abord les critères de tri traumatologique classique et les soins nécessaires seront réalisés en toute priorité.

ARBRE DE DÉCISION
N° 2

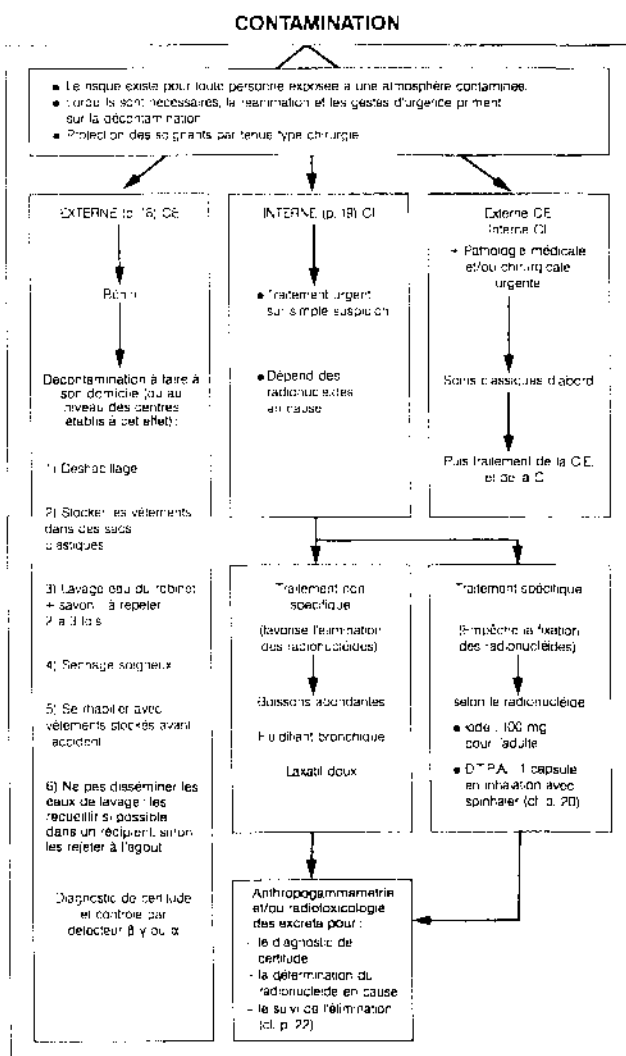

FIGURE 4



Mémento du Risque nucléaire

Association d'Information pour la Prévention
des Risques Majeurs

Figure 5

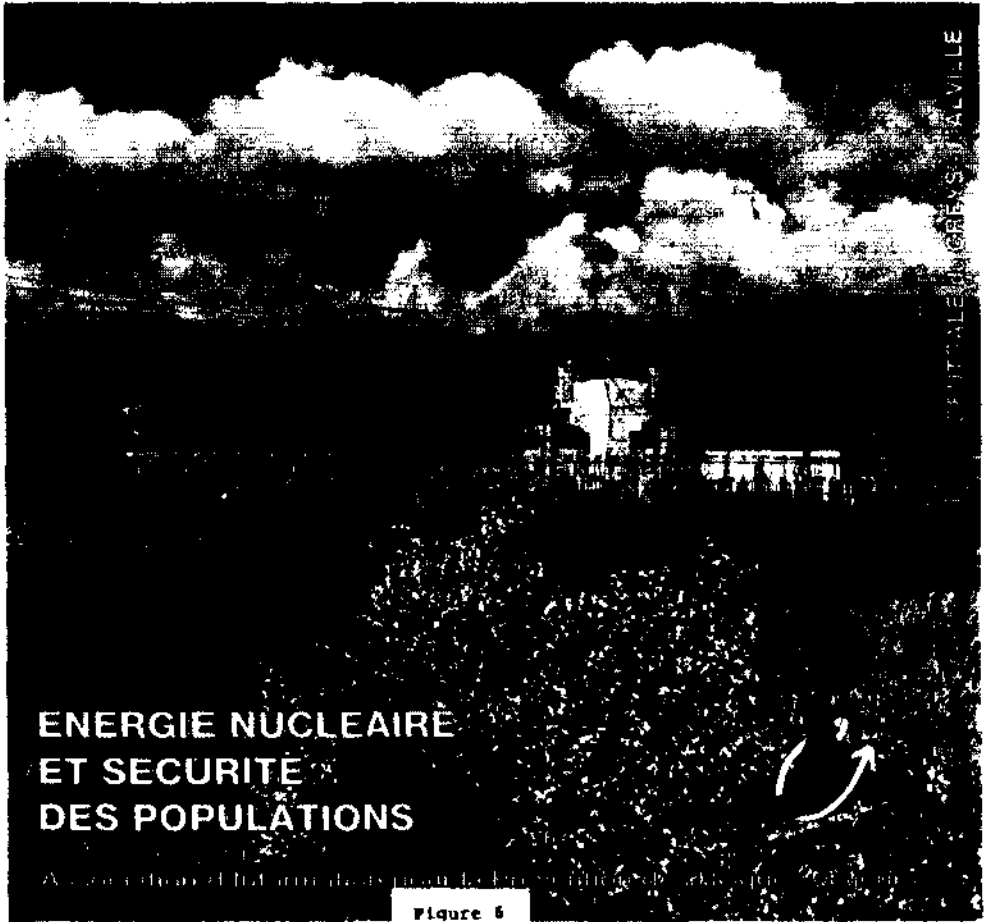

TCHERNOBYL : ANALYSE DE L'INFORMATION DONNEE PAR LES MEDIAS

D. Hubert*, J.P. Chaussade**

*Electricité de France - Comité de Radioprotection
Paris, France

**Electricité de France - Direction de la Communication
Paris, France

CHERNOBYL : ANALYSIS OF THE INFORMATION GIVEN BY THE MEDIA

Alarmist information was given by the media after Chernobyl, causing public concern on nuclear energy. Electricité de France published a document "Chernobyl, truth and falsehood" in March 1991, in order to give elements of critical analysis to the staff of the company. The information given was grouped in three parts : what is true, what is wrong and what is uncertain. This classification was established and explained on the basis of scientific and medical knowledge on the effects of ionising radiation, the scanty international scientific publications about Chernobyl, the reports by international organisations and eyewitness accounts of western people who worked in humanitarian organizations.

INTRODUCTION

A la suite de l'accident de Tchernobyl, les médias ont donné des informations diverses, parfois contradictoires et difficiles à vérifier, souvent alarmistes. Ce fut le cas à nouveau lors du quatrième anniversaire.

Face à ce flux d'informations, il est apparu nécessaire et important que l'ensemble du personnel d'Electricité de France dispose des moyens de porter un regard critique sur cet événement et ses conséquences. C'est l'objet du document "Tchernobyl : le vrai, le faux et l'incertain".

MODALITES

Dans ce but, nous avons répertorié tous les articles et toutes les émissions diffusés en France au cours de l'année 1990. Nous les avons analysés et classés par thèmes en distinguant trois types d'informations : celles dont nous pouvons confirmer la véracité, celles à l'évidence erronées et celles pour lesquelles nous ne disposons pas de données suffisantes.

Pour ce faire, nous nous sommes appuyés :

- sur les connaissances médicales et scientifiques concernant les effets des rayonnements ionisants ;
- sur les rares publications soviétiques dans des journaux scientifiques internationaux ;
- surtout sur les rapports des organismes internationaux à propos de Tchernobyl et ses conséquences (AIEA, UNSCEAR, OMS, Communautés Européennes,...) ;
- et enfin, sur les témoignages des personnes ayant séjourné en URSS au cours des dernières années, notamment dans le cadre d'organismes d'aide humanitaire (Croix Rouge, Médecins du Monde,...).

DANS LE CHAPITRE "CE QUI EST VRAI", nous avons retenu les informations sur :

- les causes de l'accident, en général bien analysées par la presse et liées à l'incompétence des exploitants, la vétusté du matériel et la conception des réacteurs soviétiques RBMK ;
- le retard à l'information de la population et les évacuations après l'accident ;
- l'étendue des zones contaminées et les décisions d'évacuations de populations dans les années suivant l'accident ;
- l'impact de l'accident sur la végétation et en particulier la forêt autour de la centrale accidentée ;
- l'état archaïque de la médecine soviétique dans la région concernée se traduisant par un manque de médecins et de matériel, ainsi que l'absence de données épidémiologiques correctes sur l'incidence des maladies avant l'accident (notamment des anomalies thyroïdiennes et des cancers) ;
- l'importance de l'irradiation thyroïdienne reçue par de nombreux enfants et le retard apporté à une prévention efficace par l'iode stable ;
- l'apparition de nombreux troubles psychologiques et maladies psychosomatiques dans la population ;
- et enfin, l'insuffisance de l'information donnée en France après l'accident.

DANS LE CHAPITRE "CE QUI EST FAUX", nous avons classé principalement des descriptions fantaisistes et erronées des effets des rayonnements ionisants, auxquels on attribue souvent les effets du stress induit par l'accident. Il est également abusif d'attribuer aux rayonnements toute maladie constatée après Tchernobyl en ne considérant ni le taux de base des maladies, ni les autres causes possibles (comme le traumatisme causé par l'accident ou les perturbations dans l'alimentation). De même les effets tardifs des rayonnements ionisants sont en général mal connus par les journalistes, qui ignorent bien souvent la nécessité d'un temps de latence après l'irradiation pour qu'un cancer puisse être considéré comme radioinduit. Ainsi peut-on catégoriquement réfuter les déclarations faisant état de "milliers de victimes soviétiques déjà emportées par des cancers dus aux radiations".

D'autre part, les médias assimilent volontiers la limite réglementaire de dose, établie dans un but de radioprotection des travailleurs et des populations, à la notion de dose dangereuse pouvant provoquer un syndrome aigu d'irradiation, voire le décès. La présentation des risques de cancer est encore plus confuse.

De nombreuses informations ayant trait aux normes alimentaires, aux contre-mesures à prendre pour la distribution et la consommation des aliments sont également fausses.

Enfin nous avons rassemblé **DANS LE CHAPITRE "CE QUI EST INCERTAIN"**, toutes les informations pour lesquelles nous n'avons pas suffisamment d'éléments pour juger ou non de leur exactitude. Ainsi en est-il :

- des doses reçues par la population puisqu'on ne dispose d'aucune dosimétrie précise ;
- du nombre exact de morts entraînés par Tchernobyl ; on ne peut exclure, qu'en plus des 31 décès officiels chez les pompiers et les employés de la centrale, quelques décès soient survenus chez les militaires et/ou des décontamineurs, dont certains ont pu recevoir des doses élevées ;
- du nombre de cancers qui sera dû à l'accident de Tchernobyl ;
- des anomalies de la thyroïde liées à l'accident puisque le taux de base n'était pas connu de façon précise auparavant ;
- du nombre d'avortements liés à l'accident ;
- du coût économique.

CONCLUSION

Ce document a largement répondu à l'attente du personnel. Certains auraient souhaité qu'il soit simplifié dans son contenu. Nous avons préféré lui conserver un bon niveau intellectuel pour éviter la simplification et la caricature. En plus du personnel, il a été très demandé à l'extérieur de notre entreprise, notamment par les journalistes, les élus et d'autres entreprises concernées par l'énergie nucléaire.

Soulignons le besoin d'une information aussi objective que possible sur les risques liés aux rayonnements ionisants, ce qui nécessite que les spécialistes de radioprotection et de santé puissent donner leur avis.

**PERCEPTION DES RISQUES ET DE LA SÉCURITÉ
CHEZ LES TRAVAILLEURS DU NUCLÉAIRE**

M.-H. Barny*, J. Brenot*, A. Moreau**

* CEA/Institut de Protection et de Sécurité Nucléaire
Département de Protection de la Santé de l'Homme et de Dosimétrie
BP 6 - 92265 Fontenay Aux-Roses Cedex - France
** CBN Saclay - France

HOW EMPLOYEES PERCEIVE RISKS AND SAFETY IN NUCLEAR INSTALLATIONS

ABSTRACT

Employees of the French centre of Saclay have been interviewed twice in November 1984 and March 1987 about their risks at the workplace, their views on safety, their protective attitudes, and also about the Chernobyl accident in the second survey. Perceived risks are compared, safety measures and protection teams are judged, importance of the Chernobyl accident is appreciated. Differences in perception between the various professional groups are pointed out. The main results are briefly presented hereafter.

LE CONTEXTE ET LES OBJECTIFS DES ENQUÊTES SUR LA SÉCURITÉ

Avec des installations de recherche fondamentale et appliquée et un effectif de plus de 6000 personnes, le Centre d'Études Nucléaires de Saclay est le plus grand centre de recherche nucléaire d'Europe. Face à la diversité des activités et des risques, la sécurité du personnel est gérée par de nombreux intervenants qui comprennent la formation de sécurité (gardiennage et incendie), les ingénieurs centraux de sécurité, le Service médical du travail, le Service de Protection contre les Rayonnements (SPR) et un Comité d'Hygiène, de Sécurité et des Conditions de Travail. Cette structure lourde et pyramidale se heurte à un certain manque de communication avec les travailleurs du Centre. Rien ne permet de connaître la façon dont le personnel voit l'organisation de la sécurité ni de prévoir les effets des messages diffusés ou de cerner le degré d'investissement du personnel dans l'application des mesures de sécurité.

Les deux enquêtes réalisées sur le Centre tentent de pallier ce manque en permettant l'expression libre du personnel et en apportant aux instances de sécurité une meilleure connaissance de ses demandes. Les questionnaires ont été envoyés individuellement aux agents. Ces envois ont été précédés d'une note du Directeur du Centre au personnel l'invitant à bien accueillir ces initiatives. Le questionnaire aborde la perception des risques et de la sécurité, et traite des comportements face aux risques. Dans la première enquête [1], en Novembre 1984, 5560 travailleurs ont été contactés et 3000 ont répondu, ce fort taux de réponse (56%) constituant déjà en soi un premier succès. L'échantillon obtenu était représentatif selon l'âge, le sexe et le statut professionnel (ouvriers, techniciens, ingénieurs et cadres administratifs). Dans la seconde enquête [2], qui s'est déroulée en Mars 1987 soit 10 mois après l'accident de la centrale nucléaire de Tchernobyl, un groupe représentatif de 2500 personnes avait été contacté. 945 personnes ont répondu qui, après vérification, peuvent être considérées comme constituant encore un échantillon représentatif.

Il existe peu de travaux publiés sur les opinions et comportements des travailleurs des installations nucléaires. Les attitudes psychologiques vis-à-vis des risques nucléaires ont été étudiés dans [3] ; trois types d'attitude avaient été dégagés : l'inquiétude (pour 15% des individus),

l'assurance (pour 5%), et la "neutralité" (pour 80%). Dans [4], connaissance du risque et perception ont été mis en relation pour diverses activités.

Les seuls résultats de la première enquête apparaissent ci-après, la seconde enquête n'ayant fait que les confirmer.

LA PERCEPTION DES SITUATIONS À RISQUES

Il s'agit du danger perçu pour un ensemble de 27 situations rencontrées tant dans l'entreprise que dans la vie courante, dans le domaine nucléaire et dans les autres domaines.

Résultats : "Brancher un appareil électrique près d'un point d'eau" (72% d'accord) est considéré comme la situation la plus dangereuse suivie par l'acte de "Fumer" (57%). Les risques de nature industrielle principalement cités sont "Vivre à proximité d'un centre de stockage de déchets chimiques" (56%) et "Travailler dans une usine de charbon" (54%) comparables avec "Boire de l'alcool pendant la journée" (54%). Il faut noter que "Travailler dans une centrale nucléaire" et "Vivre près d'une centrale nucléaire" sont considérés comme dangereux par seulement 6% et 8% des personnes interrogées, soit au même niveau que "Prendre l'avion" (4%).

LE COMPORTEMENT EN MATIÈRE DE SÉCURITÉ

Il s'agit, à travers différentes affirmations, de mieux connaître l'opinion des agents sur certains de leurs comportements sécuritaires.

Résultats : Les travailleurs demandent à être associés à la gestion de la sécurité car pour 96% "La sécurité est l'affaire de tous". Les pourcentages aux deux questions "Je ne connais rien à la sécurité" (71% de désaccord) et "Ce n'est pas à moi mais à mes supérieurs de s'occuper des problèmes de sécurité" (80 % de désaccord) confirment l'intérêt général porté à la sécurité. De plus, 76% sont d'accord pour participer à des exercices de sécurité (5% sont contre). Ils sont moyennement satisfaits de leurs conditions de sécurité, 51% seulement affirmant "Je suis satisfait de mes conditions de sécurité" (18% déclarent le contraire).

LA PERCEPTION DES MESURES PRISES

C'est la mesure de l'accord plus ou moins fort du personnel vis à-vis d'obligations (au nombre de 20) rencontrées tant dans le domaine du travail que dans la "vie privée".

Résultats : Le fait de rendre toujours les mesures de sécurité proposées toujours obligatoires est en général approuvé (taux d'accord compris entre 52% et 96%). Si la visite médicale fait presque l'unanimité (1 % seulement de désaccord), par contre, le fait d'être habilité pour pouvoir intervenir sur un circuit électrique, le contrôle des accès dans les bâtiments sont des mesures qui ne semblent pas convaincre l'ensemble du personnel.

LA PERCEPTION DES INTERVENANTS

Les positions prises sur les deux affirmations "Je vois quelle est sa fonction en ce qui concerne la sécurité" et "Je pense que j'irais le voir pour des problèmes de sécurité" permettent de mieux appréhender l'image de chacun des 13 intervenants en sécurité.

Résultats : Pour la première question, deux groupes apparaissent : les acteurs présents sur le Centre et ceux extérieurs au Centre. Le SPR est, de loin, le plus connu. Avec le plus faible score, on trouve les délégués syndicaux dont la fonction en ce qui concerne la sécurité

n'est pas très explicite. La réponse à la deuxième question dépend étroitement de l'importance de l'intervenant sur le lieu même de travail.

• **Le signalétique** des personnes interrogées, permet d'étudier les réponses faites aux rubriques précédentes en fonction du sexe, de l'âge de la situation dans l'entreprise (ancienneté, classement hiérarchique,...).

Résultats :

- Les plus jeunes aspirent à participer plus. Ils sont en général moins informés et approuvent de façon moins systématique les mesures prises.

Les femmes manifestent, en général, plus d'inquiétude. Elles sont moins impliquées dans la gestion de la sécurité. Elles ont plus tendance que les hommes à approuver les mesures de sécurité.

- Les cadres administratifs et les ingénieurs expriment en général moins leur inquiétude que les ouvriers et les techniciens.

UNE COMPARAISON ENTRE LES SECTEURS CHIMIQUE ET NUCLÉAIRE

Ces deux secteurs mettent en jeu des matières dangereuses, des installations qui peuvent être impressionnantes, des produits de haute technicité et des personnels plutôt qualifiés. Le secteur de la chimie a pour lui l'antériorité, la dissémination géographique et il fait partie de la vie de tous les jours ; le secteur nucléaire est plus récent, il se réduit à quelques grandes installations et ses produits échappent souvent au perceptible. Avec la question "La chimie, c'est plus dangereux que le nucléaire", il est possible d'évaluer les différences de perception pour ces deux domaines.

			oui	non
1982	National	- France	19 %	37 %
Novembre 1984	Travailleurs	- Saclay	42 %	20 %
Février 1986	National	- France	23 %	28 %
Juin 1986	National	- France	20 %	39 %

Dans le grand public, la chimie est considérée comme moins dangereuse que le nucléaire. Par contre, les travailleurs du Centre donnent des réponses totalement inversées. Ceci peut être dû au fait de connaître les deux types de risque, à moins qu'il ne s'agisse d'un effet de dissonance cognitive, à savoir une minimisation du risque auquel on est exposé pour pouvoir mieux supporter sa condition.

L'ACCIDENT DE TCHERNOBYL

Dans la consultation de Mars 1987, une partie du questionnaire traitait de l'accident de Tchernobyl. Les points à retenir dans les réponses sont les suivants :

L'accident de la centrale nucléaire de Tchernobyl n'a pas modifié l'opinion que les agents du Centre avaient sur la proposition "La chimie c'est plus dangereux que le nucléaire" : il y a toujours environ 45 % de oui pour 20 % de non. Il n'y a pas non plus de changements importants dans la perception des situations à risque. En moins de quatre ans, les opinions favorables aux deux propositions suivantes : "J'ai été informé des risques que je cours sur mon lieu de travail" et "Je suis satisfait de mes conditions de sécurité à Saclay" sont passées de 50% d'accord à plus de 60 % en 1987. Les femmes montrent malgré tout plus de réticence que les hommes.

Concernant l'accident plus particulièrement, un agent sur deux a été sollicité par ses proches pour répondre à des questions sur Tchernobyl. Dans leurs avis, les agents du Centre sont généralement plus modérés que les individus du public : ils croient moins à

l'éventualité d'un tel accident en France (32 % au lieu de 54 % environ dans le public), la confiance est plus grande chez les cadres (62 % d'entre eux n'envisagent pas cette éventualité) que chez les agents techniques ou employés (où ils sont seulement 40 %). Les explications des experts sont plus compréhensibles pour eux que pour le public : cela est vrai pour un travailleur sur trois à Saclay mais seulement pour un individu sur cinq dans le public. Il apparaît que les travailleurs de Saclay n'ont pas grande confiance en l'organisation de la sécurité : 58 % estiment que la protection des populations ne peut être assurée en cas d'accident dans une centrale nucléaire en France (et 21% seulement le pensent). Par contre, ils répondent beaucoup plus positivement, à plus de 70 %, en ce qui concerne leur protection en cas d'accident sur le Centre.

CONCLUSION

Dans les résultats présentés, on constate une grande diversité dans les perceptions tant des risques que de la sécurité. Cette diversité résulte bien entendu de l'expérience de chacun mais aussi de son rôle dans l'organisation du travail. Le fait d'appartenir à une collectivité transparait lorsque l'on compare les réponses ici obtenues à celles du grand public. Certaines catégories de travailleurs (par exemple, les personnels de bureau) ont sur les activités à risque des conceptions déformées et souvent excessives qui nécessitent des responsables de l'entreprise un effort d'information et même de formation. Cet effort s'impose d'autant plus que tout travailleur du secteur nucléaire, dans ses relations avec ses proches, a un rôle plus ou moins important de communication externe. Au delà des résultats, l'enquête a provoqué une dynamique entre les différents intervenants, permis une expression du personnel dégagée du cadre institutionnel, donné l'occasion de réunions au cours desquelles les travailleurs ont pu réfléchir sur les quatre thèmes proposés dans le questionnaire. La consultation est ainsi devenue un des outils d'animation de la sécurité à un échelon aussi proche que possible du poste de travail.

RÉFÉRENCES

1. BASTIDE S. - MOREAU A., "Enquête sur la perception de la sécurité par le personnel du centre d'études nucléaires de Saclay", Revue Générale du Nucléaire n°6, 1986, pp. 536-542.
2. BASTIDE S. - UZZAN K. MOREAU A., "Enquête sur la perception de l'accident de Tchernobyl par le personnel du centre d'études nucléaires de Saclay - Rapport principal", Octobre 1987, Note LSEES n° 87/26.
3. SIVADON P. - FERNANDEZ A., "L'étude des attitudes psychologiques des travailleurs nucléaires vis-à-vis du risque radioactif", Centre de recherches psychopathologiques, Paris-France, 1968, Contrat Euratom n°002-62-10 PSTF
4. SJOBERG L. - DROTTZ-SJOBERG B.M., "Knowledge and Risk Perception among Nuclear Power Plant Employees". In: "Perception of Risk - Studies of Risk Attitudes, Perceptions and Definitions", Center for Risk Research, Stockholm 1991, pp. 140-162.

REMERCIEMENTS

Les travaux présentés ont bénéficié d'un financement des Communautés Européennes : contrat d'Association Euratom CEA DCXII B16-122F(D).

**EVALUATION DES CONSEQUENCES RADIOLOGIQUES
DES REJETS GAZEUX EN SITUATION
ACCIDENTELLE**

Y.H. BOUGET

Electricite de France
Service de la Production Thermique
Paris - La Défense

**METHOD AND TOOLS FOR ASSESSING THE
OFF-SITE CONSEQUENCES OF A NUCLEAR
ACCIDENT**

When an accident, with possible gaseous release, occurs in a nuclear power plant, the utilities must be capable of providing the Authorities with information about release radiological consequences and this in a very short time. The difficulties encountered in assessing radiological consequences during crisis exercises (lack of time for doing manual calculation, difficulty in getting useful information about the accident ...) have led Electricité de France, in collaboration with the Commissariat à l'Energie Atomique, to settle a simple method and efficient tools for local crisis teams.

INTRODUCTION

Lorsque survient, dans une centrale nucléaire, un accident susceptible d'engendrer des rejets radioactifs dans l'environnement, l'exploitant doit être en mesure de fournir à l'Administration, dans des délais courts, des informations relatives aux conséquences radiologiques des rejets prévisibles ou en cours.

Ces informations sont capitales pour permettre à l'Administration de décider des éventuelles mesures de protection à prendre vis-à-vis des populations avoisinantes.

Les exercices réalisés dans le cadre de l'organisation de crise ont montré que les responsables chargés d'évaluer les rejets dans l'environnement (terme-source) ne disposaient pas des moyens suffisants pour réaliser les prévisions. Ces dernières étaient en effet établies à partir des résultats très pessimistes issus des études d'accident figurant dans les rapports de sûreté des centrales. D'autre part, les calculs des conséquences radiologiques (équivalents de dose reçus par le public), effectués manuellement à l'aide d'abaques opérationnels, nécessitaient beaucoup de temps et étaient cause d'erreurs.

Ces difficultés ont conduit Electricité de France à développer, avec la collaboration du Commissariat à l'Energie Atomique (C.E.A), une méthode et des moyens simples permettant aux équipes de crise des centrales d'effectuer plus facilement et plus rapidement les évaluations des rejets gazeux.

METHODE ET OUTILS DE CRISE POUR L'EVALUATION DES REJETS GAZEUX

La méthode d'évaluation s'appuie sur les recommandations de la publication n° 40 de la C.I.P.R. [1] et sur les éléments de doctrine énoncés dans le Plan Sanitaire d'Urgence [2].

Celle-ci est structurée en 3 parties et permet :

- de suivre à tout moment l'évolution des rejets en cours et d'en calculer les conséquences radiologiques à l'aide d'un outil informatique,
- d'évaluer de façon réaliste, dès le début de l'accident, l'enveloppe des rejets prévisibles en considérant non plus les résultats des scénarios d'accident, mais un ensemble de données pré-établies en fonction de l'état du combustible et du confinement,
- d'interpréter les premiers résultats des mesures de radioactivité pratiquées dans l'environnement pendant les rejets.

Les moyens ou outils élaborés à partir de cette méthode se composent :

- d'un document "papier" fournissant tous les éléments nécessaires à la détermination de l'activité rejetée ou susceptible d'être rejetée (prévisions),
- d'un logiciel fonctionnant sur un micro-ordinateur PC pour le calcul des conséquences radiologiques des rejets.

Le document "papier" (Fig. 1) fournit les données relatives :

- aux activités contenues dans les circuits et dans le combustible,
- aux rejets potentiels, pré-calculés pour différents cas de figure en fonction de l'état du combustible, du confinement et de la disponibilité de certains matériels tels que le circuit d'aspersion de l'enceinte et les pièges à iode des circuits de ventilation (9 états ont été définis, couvrant toutes les

situations accidentelles, de la petite brèche primaire jusqu'aux accidents avec fusion du coeur). Cet ensemble de données permet de réaliser des prévisions sans faire de calcul,

- aux ordres de grandeur des activités mesurables dans l'environnement selon la gravité de l'accident.

De plus, ce document comprend un logigramme de surveillance de certains paramètres-clés caractérisant l'état des 3 barrières (gainage du combustible, circuit primaire, enceinte de confinement). La scrutation de ce logigramme permet aux équipes de crise locales d'être averties de tout événement pouvant conduire à des rejets importants.

Le logiciel de calcul utilise un modèle de diffusion atmosphérique développé par le CEA. Ce modèle calcule en fonction de la distance et de la météorologie locale :

- la dose organisme entier due au passage du nuage,
- la dose à la thyroïde due à l'inhalation d'iode radioactif,
- les débits de dose dus aux dépôts.

CONCLUSION

Cette méthode et ces outils ont été testés lors des exercices de crise. Ils ont révélé leur efficacité pour faire des évaluations précoces (jusqu'à 24 heures après l'accident).

Ces outils essentiellement conçus pour les techniciens des centrales ne prétendent pas remplacer le travail des experts, en particulier ceux qui seraient présents dans les centres de crise et qui disposeraient d'outils informatiques plus précis pour déterminer l'impact réel de l'accident.

BIBLIOGRAPHIE

- [1] Protection of the public in the event of major accident
ICPR 40
- [2] Plan Sanitaire d'Urgence - Institut Curie - CEA
- [3] Directive interministérielle n° 4600 du 13 mars 1985
- [4] Evaluation des conséquences radiologiques des rejets gazeux
P. HARTMANN - EDF - SRE/EV 90/859

Figure 1 :
Extraits du document papier destiné aux
équipes locales de crise

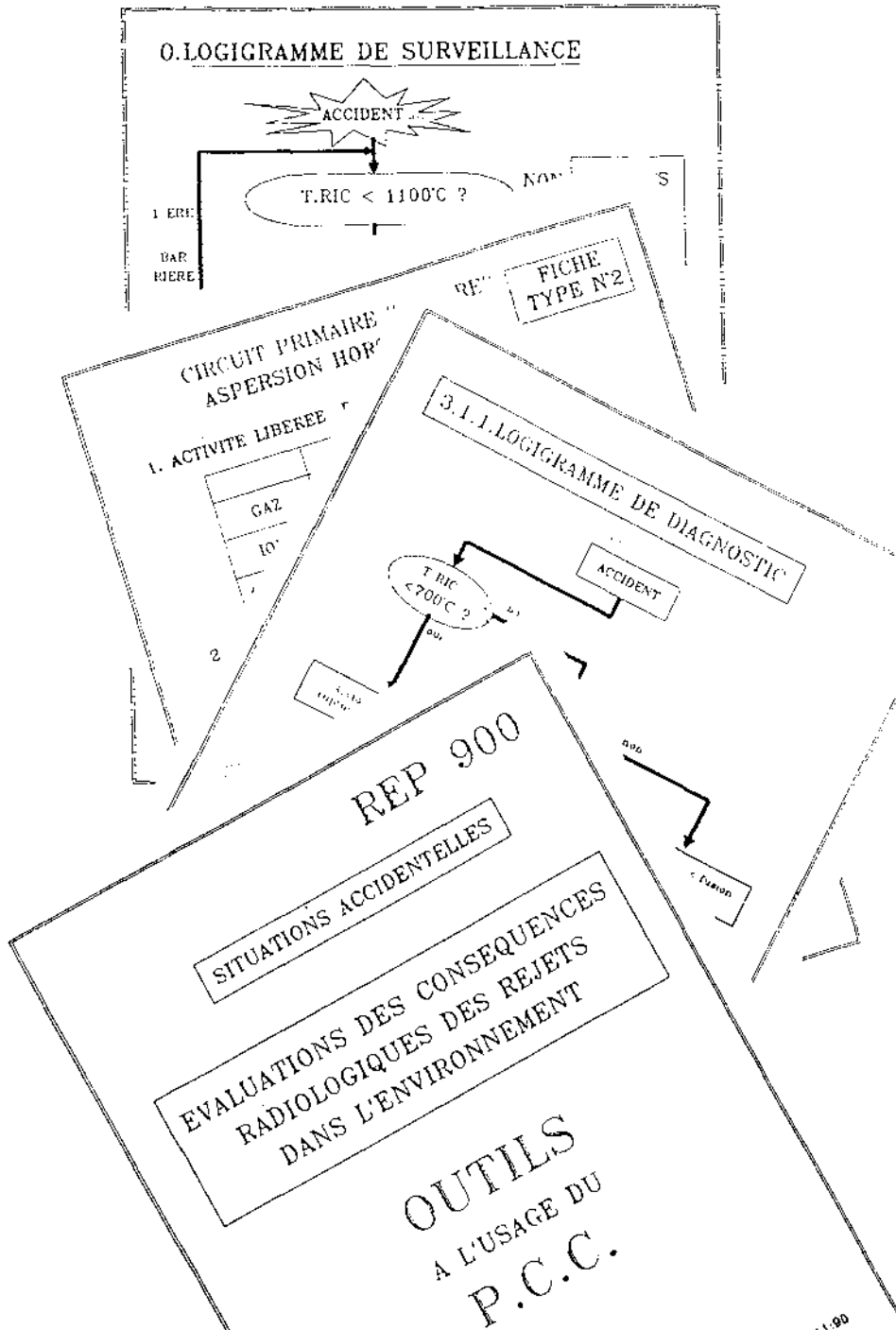

PUBLIC EXPOSURE RESULTING FROM DISCHARGES TO ATMOSPHERE FROM THE NUCLEAR FUEL REPROCESSING PLANT AT SELLAFIELD IN THE UNITED KINGDOM

S R Jones and M J Fulker

British Nuclear Fuels plc,
Sellafield, Seascale, Cumbria, UK.

ABSTRACT

Discharges of radionuclides to atmosphere from the Sellafield reprocessing plant include noble gases, volatile species, and particulates.

Doses to the critical group estimated by environmental monitoring in 1990 were about $160 \mu\text{Sv y}^{-1}$ committed effective dose equivalent (CEDE), making conservative assumptions regarding critical group habits. Doses calculated from a pessimistic generic predictive model were similar.

However detailed studies have allowed more accurate and site specific parameters to be adopted for atmospheric dispersion, foodchain transfer of key radionuclides, and critical group habits. This model indicates that the critical group doses from 1990 discharges would have been substantially lower, at $45 \mu\text{Sv y}^{-1}$ or less.

INTRODUCTION

The Sellafield site, operated by British Nuclear Fuels plc, is located in Cumbria, NW England. A variety of nuclear process plants are situated on the site, including reprocessing and associated chemical plants, high and intermediate level waste conditioning and storage facilities, and four nuclear power reactors of the Magnox type.

Discharges to the atmosphere are made via seven major discharge stacks and numerous minor roof level outlets. Radionuclides discharged include the noble gases 85Kr and 41Ar ; other gases and volatiles including 3H , 14C , 131I and 129I ; and particulates contaminated with fission products and actinides such as 90Sr , 106Ru , 137Cs , 238Pu , $239/240\text{Pu}$, 241Pu , and 241Am . Details of the quantities discharged are reported elsewhere (1). Public radiation exposure resulting from the discharges is estimated in two ways.

A routine environmental monitoring programme is carried out, which enables radiation exposure to be estimated from concentrations in the environment and assumptions regarding habits. Current (1990) levels of dose to the public, estimated in this way, are about $160 \mu\text{Sv y}^{-1}$ (CEDE).

However environmental monitoring in itself is not sufficient; not all components of dose can be adequately assessed by monitoring, and there is a need to predict the radiation doses which will result from future discharges. This need is met by models. A simple and conservative model is used as the basis for discharge planning (2); this uses a conventional Gaussian atmospheric dispersion model (3), an empirical method of assessing the effective height of releases (4) and a generic foodchain transfer model (5). The model calculates the sum of doses to the limiting age group for each nuclide. The predicted doses from 1990 discharges are given in Table 1, and agree quite well with the estimates from environmental monitoring.

This overall agreement is however fortuitous, and conceals a number of discrepancies in the doses arising from specific radionuclides. These discrepancies reflect inadequacies in the generic equilibrium models applied, and have been addressed in a number of research projects aimed at producing a more reliable site specific environmental model. The main areas of investigation are summarised below.

ATMOSPHERIC DISPERSION

The Gaussian plume model (3) assumes an isolated release stack situated on a uniform flat plane with a uniform wind rose, the effective height of release being modified to take some account of the structure on which the stack is situated (4). However the Sellafield site is complex, and it is necessary to also take account of the effects on dispersion of surrounding buildings. Dispersion behaviour has been investigated for a range of outlets using models from 1/200 to 1/500 scale in a wind tunnel, and at full-scale for ground level outlets by releasing the tracer gas SF₆ (5).

The results indicate that most tall stacks have a lower effective height than the empirical rule suggests; however dispersion from ground level releases is somewhat greater than indicated by the Gaussian plume model. These findings are attributed to the effects of downwash and the effect of turbulence from buildings on plume mixing, which appears to increase the horizontal and vertical standard deviations (σ_y and σ_z) of the Gaussian plume.

For the present, these effects have been allowed for in the model by assigning effective heights to each release point so that the correct dispersion factor is predicted at the distance relevant to the critical group; more sophisticated treatments may be developed. The net effect is to somewhat increase the predicted critical group doses for most radionuclides.

CARBON 14

The concentration of carbon 14 incorporated in biota is usually calculated by a specific activity model, which assumes that the 14C content is determined by the value of the ratio of 14C to stable carbon in air; the latter can be estimated directly from the atmospheric dispersion model, as an annual average.

Measurements of 14C in vegetables and milk near Sellafield showed higher 14C: stable carbon ratios than predicted; moreover, the ratio varied significantly from one sample type to another, suggesting that the specific activity model was inapplicable. Pending further investigation, an arbitrary factor of pessimism (x10) was incorporated into the model.

Investigations have now confirmed that the effect is caused by systematic variations in the dispersion pattern through the course of the year (7,8). Plants incorporate 14C by photosynthesis only during daylight hours during their growing season; the average 14C: stable carbon ratio over this specific period correlated well with the ratio in biota, and differs from the annual average ratio principally because of sea breeze effects.

Understanding this effect has allowed the factor of pessimism in the model to be reduced.

IODINE 129

The routine environmental monitoring programme for I291 covers only milk. Regulators had expressed concern that alternative foodchain models indicated the possibility of significant uptake of this long lived nuclide from soil to root crops; however a special measurement campaign has confirmed that milk is indeed that most important exposure route, consistent with findings elsewhere (9). These studies also permitted the adoption of a lower transfer factor for I291 from grass to milk, although the new value is still believed to be conservative.

ARGON 41

Direct radiation from the ⁴¹Ar released in shield cooling air from the Magnox reactors remains the single most significant source of radiation exposure consequent on discharges to atmosphere from the site. These doses are currently calculated purely from the dispersion model, direct measurement being difficult in the presence of natural radiation. Studies at Magnox power stations operated in the UK by Nuclear Electric plc have shown that the doses so calculated are pessimistic; this is currently under investigation.

CRITICAL GROUP HABITS

Previously, pessimistic assumptions have been made concerning the habits of the critical group. A hypothetical group has been defined, living 700 m from the point of discharge (or at the point of maximum concentration); residing permanently at that location; and subsisting entirely on food grown at 1.5 km from the point of discharge (with the exception of grain products) consumed at rates typical of a high rate consumer.

This situation clearly did not exist in practice; accordingly a survey was carried out to determine actual food consumption and other exposure-related habits (12). This showed that, while the maximum consumption rates for individuals and for particular food groups were not dissimilar to the assumed values for the critical group, that no individual simultaneously consumed all foods at the maximum rates. Of course, distances to places of residence and food production generally exceeded the values assumed.

Using data from this habit survey, a dose distribution for the survey population has been calculated, using the predictive environmental model, which shows that the average dose for the population living on farms or isolated households around the site is about a factor of four lower than that for the pessimistic critical group; whereas the dose to the highest exposed individual is about two thirds of that for the pessimistic critical group (13).

There was only one infant in the survey population, so it was not possible to derive realistic group average habits for this critical age group. Nonetheless the survey results have been used to define more realistic critical group average consumption habits for other age groups (10 year old and adult).

Using these more realistic critical group parameters has a major impact on calculated doses.

IMPROVED DOSE ESTIMATES

The amendments described above have been incorporated into the predictive model and revised doses can be calculated, as indicated in Table 1. These are substantially lower than the earlier estimates.

The revised doses from 1990 discharges are also lower than the doses estimated from environmental monitoring. This partly reflects the fact that environmental monitoring data relate to the areas of highest concentration, rather than the locations where people actually live; in addition, the predictive model is an equilibrium model which calculates doses resulting from equilibration of the environment with discharges at 1990 levels whereas the monitoring data reflects some residual effects of higher discharges in the past.

CONCLUSIONS

Refinement of the predictive model for discharges to atmosphere from the Sellafield site has led to some changes which increase calculated doses (atmospheric dispersion) and some which reduce calculated doses (foodchain transfer and critical group habits). Overall, refinement of the model has led to substantial reductions in calculated doses.

Such model refinement is essential if radiological input to effluent management decisions is to be useful, since decisions on effluent treatment options require accurate information as to both absolute levels of radiation dose to be expected, and the relative significance of individual discharge sources and radionuclides.

Table 1

Nuclide	Total release 1990 TBq y ⁻¹	Doses calculated from environmental models μSv y ⁻¹ CEDE			
		Initial Model	Infant	Refined Model 10 yr Adult	
HT	5.9E2	5.8E-6	1.7E-6	6.9E-6	1.1E-5
H ³ O	5.5	1.1E-1	4.3E-2	2.4E-2	2.1E-2
C14	3.9	2.9E+1	1.7E+1	6.9	7.0
S35	2.4E-2	2.9E-1	2.2E-1	8.9E-2	2.1E-1
Ar41	2.5E3	5.8E+1	1.5E+1	1.5E+1	1.5E+1
Co60	5.2E-4	6.8E-2	2.4E-2	1.7E-2	1.7E-2
Kr85	3.76E4	7.9E-2	1.4E-1	1.4E-1	1.4E-1
Sr90	1.61E-1	1.4E+1	1.2E-1	1.5E-2	1.4E-2
Ru106	2.3E-3	8.3E-2	1.3E-2	1.4E-2	1.0E-2
Sh125	1.3E-4	4.4E-3	9.6E-4	7.8E-4	7.7E-4
I129	1.4E-2	2.0E+1	1.1E+1	9.7	7.5
I131	1.6E-3	2.9E-1	3.5E-1	8.7E-2	3.4E-2
Cs137	2.1E-3	1.9E-1	6.1E-2	5.5E-2	1.0E-1
Pu(alpha)	1.6E-4	2.5	2.0E-1	4.2E-1	5.1E-1
Pu241	1.2E-3	3.1E-1	2.1E-2	5.9E-2	7.4E-2
Am241	7.1E-5	1.9	1.3E-1	2.7E-1	3.3E-1
Totals		1.3E2	4.5E+1	3.3E+1	3.1E+1

REFERENCES

- 1 Radioactive Discharges and Monitoring of the Environment 1990: British Nuclear Fuels plc, Health and Safety Directorate, Risley, Warrington, Cheshire (1991).
- 2 A D Smith and M J Fulker: Modelling the radiological impact of airborne materials released during routine operations at Sellafield. Radiation Protection: Theory and Practice, pp 325-328, IOP Publishing, Bristol, 1989.
- 3 R H Clarke: A model for short and medium range dispersion of radionuclides released to atmosphere. NRPB-R91, HMSO, 1979.
- 4 P M Bryant: Methods of estimation of the dispersion of windborne material and data to assist in their application. AHSB(RP)R41, HMSO, 1964.
- 5 J R Simmonds, and M J Crick: Transfer parameters for use in terrestrial foodchain models. NRPB-M63, HMSO, 1982.
- 6 S Singh and M J Fulker: A wind tunnel examination of σ_y and σ_z . 5th EURASAP International Workshop, Warren Spring Laboratory, 1991.
- 7 R C Otlett, A J Walker and M J Fulker: Survey of the dispersion of ^{14}C in the vicinity of the UK reprocessing site at Sellafield. Radiocarbon 32 1 pp 23-30, 1990.
- 8 R C Otlett, A J Walker and M J Fulker: The transfer of ^{14}C to foodstuffs from experiments on a controlled plot in Cumbria. Radiation Protection; Theory and Practice, pp 393-396, IOP Publishing, Bristol, 1989.
- 9 J Hauschild and D C Aumann: Iodine-129 in the environment of a nuclear fuel reprocessing plant (V). J Environ. Radioactivity 9 pp 145-162, 1989.
- 10 H F MacDonald, I M G Thompson et al: Improved estimates of Argon 41 gamma doserates around Hinkley Point power station: Radiation Protection; Theory and Practice, pp 379-382, IOP Publishing, Bristol. 1989.
- 11 N T Harrison and J R Simmonds: Dosimetric quantities and basic data for the evaluation of generalised derived limits. NRPB-DL3, HMSO 1980.
- 12 T H Stewart, M J Fulker and S R Jones: A survey of the habits of people living close to the Sellafield reprocessing plant. J Radiol. Prot 10 (2) pp 115-122, 1990.
- 13 S R Jones, M J Fulker et al: Aspects of population exposure consequent on discharges of radionuclides to the environment from the nuclear reprocessing plant at Sellafield in Cumbria. Radiation Protection Dosimetry 36 2/4 pp 199-204, 1991.

THE HISTORY OF CRITICAL GROUP DOSES FROM THE CONSUMPTION OF FRESHWATER FISH AT
TRAWSFYNYDD, NORTH WALES

D R P Leonard
Fisheries Radiological Inspectorate,
Ministry of Agriculture, Fisheries and Food
Directorate of Fisheries Research, Fisheries Laboratory,
LOWESTOFT, Suffolk, UK

ABSTRACT

Radionuclides discharged into the aquatic environment from Trawsfynydd power station are, as for all UK facilities, subject to statutory controls to ensure that the resulting public radiation exposure complies with nationally-accepted criteria. Environmental monitoring by MAFF has shown that near this facility the consumption of freshwater fish is radiologically the most important pathway with Cs-137 the dominant radionuclide. Information gathered from consumers over a twenty-five year period has been interpreted so as to derive doses to the public. Committed effective doses (CEDs) are presented using ICRP 1990 methodology and compared with the recommended dose limit of 1 mSv year⁻¹. Doses to the critical group are shown to have exceeded 1 mSv year⁻¹ for two years but do not exceed this limit when averaged over a period of 5 years. Because of the changing habits of the consumers it is suggested that the average annual CED over the lifetime of any member of the public will not exceed 1 mSv year⁻¹ during the operation of the station.

INTRODUCTION

The 390 MW(e) (nominal) twin gas cooled Magnox type reactors presently operated by Nuclear Electric plc at Trawsfynydd, North Wales commenced commercial operation in 1965. An authorisation was granted to discharge small quantities of low level liquid radioactive waste into the adjacent freshwater lake. Such authorisations are granted by Government Departments under the Radioactive Substances Act (1960) and kept under review. In setting and reviewing these limits, full consideration is given to the environmental implications of discharging this waste and particular attention is paid to the exposure pathways of the public. This paper considers public exposure from the consumption of fish from the lake between 1962 and 1990 and especially those people who are potentially the most exposed, the so called critical group.

METHODS

Post-hoc (ie non-predictive) assessment of dose to a critical group of fish consumers makes use of results from an appropriate environmental monitoring programme (Leonard and Hall, 1989), information about peoples consumption rates and suitable dose per unit intake data. At Trawsfynydd, consumption rate data are primarily derived from interviews with anglers and people whom they supply (Leonard et al., 1982). Enthusiastic anglers usually possess season tickets and belong to the lake's angling association, which has been a valuable source of information throughout the life of the power station and lists of members have formed a basis from which habits surveys could be conducted. The first major habits survey took place in 1962 and has been carried out at approximately five-yearly intervals ever since. Lake bailiffs and potential critical group members were regularly consulted between surveys to ascertain if consumption habits had changed. Some high rate consumers were asked to keep a diary of their catch and consumption rates. During the survey, each family was asked to estimate their individual consumption rates, the number, size and species of fish caught during a calendar year as well as seasonal preferences and cooking methods. Consumption of children was considered (Leonard and Hunt 1985). Interviews were also conducted with anglers who purchase day tickets. The surveys were specifically designed to try and identify high rate consumers rather than being targeted randomly. The data were collated to provide individual consumption rates for each species of fish expressed in kg year⁻¹. It was found that the following

factors limit consumption rates of the indigenous trout: only six trout can be taken on any one day and stocked rainbow trout (*Salmo gairdneri*) now outnumber brown trout (*Salmo trutta*) by a ratio of about 6:1. The former contain low concentrations of lake derived radionuclides, usually being caught within three weeks of release. The indigenous brown trout are preferred by many consumers but are relatively more difficult to catch. Some consumers may prefer perch or a combination of species. Analysis of individual consumption and interview data showed that high rate consumers were either skilled anglers themselves or a relative or friend of such anglers. Because of the amount of time required to catch large quantities of fish, critical group consumers tend to be either retired or associated with the management of the fishery.

The initial study showed that Cs-137 was the most dominant radionuclide. Fish sampling commenced in 1961 with the collection of brown trout when concentrations of Cs-137 averaged 17 Bq kg^{-1} (wet) due to nuclear weapons test fallout. In 1962 mean concentrations increased to 53 Bq kg^{-1} and reached 164 Bq kg^{-1} at the end of 1964, prior to power station operation (Preston et al., 1967). Perch (*Perca fluviatilis*) were sampled for comparison from 1965. Angling increased in popularity because the warm water discharges promoted fish growth; however, the indigenous brown trout population could not support the number of anglers who wished to fish at Trawsfynydd and thus rainbow trout were introduced to the lake from 1973, and sampling of this species commenced at this time. Other species such as rudd (*Scardinius eryththalmus*) and eel (*Anguilla anguilla*) have also been monitored although they are not regularly eaten. Ideally, a sample of each species has consisted of six to ten fish which was caught by MAFF staff using gill nets or purchased by MAFF from rod and line anglers using a wide range of baits. These anglers were asked to provide monthly or quarterly samples during the fishing season which extends from March to September for brown trout, February to December for rainbow trout and for perch. Usually quarterly samples were collected by MAFF staff.

Cs-137 was detected in all species of fish with the highest concentrations usually occurring in perch, followed by brown trout, rudd, eel and finally rainbow trout. Other radionuclides were also detected and these included Cs-134, Sr-90, S-35, Co-60, Mn-54, Ru-106, Pu-238, Pu-239+240, Pu-241, Am-241, Cm-242 and Cm-234+244.

Assessment of dose

The International Commission on Radiological Protection (ICRP) has made a series of recommendations that now embody three fundamental principles of justification, optimisation and dose limitation. In recent years, UK practice has been based on the recommendations of Publication 26 (ICRP 1977); the effects of Publication 60 (ICRP 1990) are currently being considered. This study examines the effect of ICRP 60 recommendations, noting that while the limit for the CED to members of the public is the same as the previous principal limit at 1 mSv year^{-1} , the new limit is slightly more stringent because it refers to a five year limit rather than a lifetime. A higher effective dose than 1 mSv is permissible in a single year provided that the annual CED averaged over 5 years does not exceed 1 mSv year^{-1} . The ICRP recommendations apply to doses to appropriate critical groups. In this study, the approach of Hunt and Shepherd (1980) was used from 1973 onwards. However, during the 1962 and 1968 survey the concept of a maximum consumer and a mean for all consumers was used. Using such means is likely to underestimate the dose to the high rate consumers and therefore a nominal consumption rate derived from the early data of $36.5 \text{ kg year}^{-1}$ of brown trout has been used in this study. For comparative purposes, results based on this consumption rate have also been calculated from 1965 when discharges commenced to the end of 1990. Using environmental monitoring data from the MAFF annual monitoring reports (eg. Hunt 1989) the CED was calculated utilising dose per unit intake data (Phipps et al., 1991). Cs-137, Cs-134 and Sr-90 were found to be the radiologically most significant nuclides. The other radionuclides typically contribute about 1% of the total annual dose. Figure 1 shows a plot of the total

annual dose from Cs-137, Cs-134 and Sr-90 in mSv year^{-1} plotted against time for the critical groups of consumers identified during the habits surveys and a hypothetical group consuming $36.5 \text{ kg year}^{-1}$. Neither group has exceeded 2 mSv year^{-1} but both groups have exceeded the 1 mSv year^{-1} limit in 1976 and 1977.

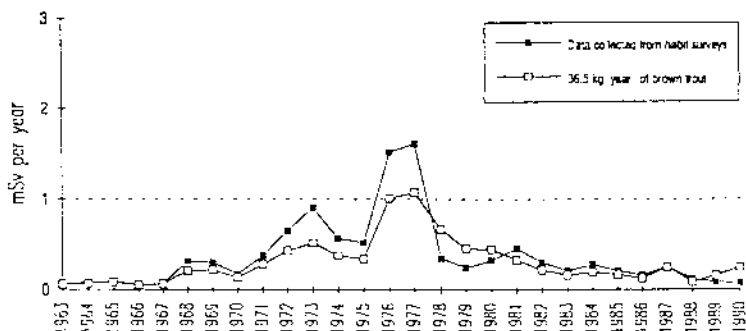

Figure 1. A graph showing the CED from Cs-137, Cs-134 and Sr-90 (mSv year^{-1}) to the critical group of fish consumers from 1963 to 1990 compared to a hypothetical group consuming $36.5 \text{ kg year}^{-1}$ of brown trout.

DISCUSSION

The cumulative CED for the critical group of fish consumers from 1965 to 1990 is approximately 12 mSv . This includes the contribution from the major and minor radionuclides, due to the power station's discharges as well as a small contribution from nuclear bomb test fallout and the Chernobyl reactor accident. On the basis of a hypothetical critical group of brown trout consumers eating at $36.5 \text{ kg year}^{-1}$, for the same period the comparative dose would only have been 10 mSv . Assessment of individuals who are or who have been members of the critical group and other consumers for whom several years data were available, showed that nobody was likely to have exceeded 10 mSv from the consumption of freshwater fish from Trawsfynydd over the twenty-five years that the power station has been operating. The dose from the ICRP model for Cs-137 is likely to be cautious based on the whole body monitoring of consumers near Sellafield which suggested that the parameters in the model for caesium retention would be unlikely to underestimate body content (Hunt et al 1989). When the authorised limits for discharges are reviewed, a predictive assessment is made to consider the maximum CED that could occur; thus it is now unlikely that the average annual CED over the life time of any member of the public will exceed 1 mSv year^{-1} . It is to be noted that dose assessments also need to consider other exposure pathways such as external exposure from lake bank occupancy, consumption of terrestrial foodstuffs, inhalation and immersion from Ar-41. MAFF have published such assessments (Hunt 1989, Tarrant 1991) and considered that the additional dose to high rate fish consumers is likely to be small. The additivity of dose from different pathways continues to be reviewed.

CONCLUSIONS

Monitoring and assessment of critical group fish consumers at Trawsfynydd for almost thirty years has demonstrated that the annual CED has exceeded 1 mSv for two of those years but not exceeded 1 mSv year^{-1} when averaged over a period of five years. ICRP recommendations, even applied retrospectively, have therefore been met.

ACKNOWLEDGEMENTS

The data used in this paper could not have been obtained without the cooperation of the Prysor Angling Association and its members. Particular thanks are given to the late Mr M Lewis, Mr D G Williams and Mr M Atherton. The help of a large number of MAFF staff with the interviews and environmental monitoring are also gratefully acknowledged especially Mr C J Hewett, Dr P G W Jones, Miss L M Thurston and Mr J R J Tipple.

REFERENCES

- Great Britain - Parliament., 1960. Radioactive Substances Act, 1960. HMSO, 28pp
- Hunt, G.J., (1989). Radioactivity in surface and coastal waters of the British Isles 1988. Aquat. Environ. Monit. Rep., MAFF Direct. Fish. Res., Lowestoft. AFMR 21, 69 pp.
- Hunt, G.J. and Shepherd, J.C., (1980). The identification of critical groups, pp. 141-145 In: A. Eisenberg (Editor) "Radiation Protection: a Systematic Approach to Safety". Volume 1. Proc. 5th Int. Congr. IRPA, Jerusalem, 1980. Pergamon Press, Oxford and New York, 1234 pp.
- Hunt, G.J., Leonard, D.R.P. and Fry, F., (1985). High-rate seafood consumers near Sellafield: comparison of conventional assessments of caesium-137 intakes with the results of whole-body monitoring. *Rad.Prot.Dosim.* 27(1)35-41.
- International Commission on Radiological Protection, 1977. Recommendations of the International Commission on Radiological Protection. *Annal. ICRP* 1(3). Pergamon Press, Oxford, 83pp. (ICRP Publ. (26)).
- International Commission on Radiological Protection, 1990. Recommendations of the International Commission on Radiological Protection. *Annal. ICRP* 21 (1-3). Pergamon Press, Oxford, 201pp. (ICRP Publ. (60)).
- Leonard, D.R.P., Hunt, G.J. and Jones, P.G.W., (1982). Investigation of individual radiation exposures from discharges to the aquatic environment - the technique of habits surveys. pp. 512-517 In Proceedings of the 3rd International Symposium on Radiological Protection - Advances in Theory and Practice, Inverness, 6-11 June 1982. Vol. II. *Soc. Radiol.Prot.*
- Leonard, D.R.P. and Hunt, G.J., (1985). A study of fish and shellfish consumers near Sellafield: Assessment of the critical groups including consideration of children. *J. Soc. Radiol. Prot.* 5(3) 129-138.
- Leonard, D.R.P. and Hall, I.R., (1989). The design and implementation of an environmental monitoring programme around the Torness nuclear power station. pp. 375-378. In E.P.Goldfinch (Ed.), Radiation Protection - Theory and Practice Proc. 4th Int. Symp. Soc. Radiol. Prot., Malvern 4-9 June 1989. Institute of Physics, Bristol and New York.
- Phipps, A.W., Kendall, S.M., Stather, J.W. and Fell, T.P., (1991). Committed Equivalent Organ Doses and Committed Effective Doses from Intakes of Radionuclides. Chilton, National Radiological Protection Board-R245.
- Preston, A., Jefferies, D.F. and Dutton, J.W.R., (1967). The concentrations of caesium-137 and strontium-90 in the flesh of brown trout taken from rivers and lakes in the British Isles between 1961 and 1966: the variables determining the concentrations and their use in radiological assessments. *Wat. Res.*, 1: 475-496.
- Tarrant, C. E., (1991). Mathematical modelling methods for assessing radiation doses received by populations in the vicinity of a nuclear site from atmospheric discharges. *Radiol. Prot. Dosim* 36 2/4 : 211-214.

COMPARATIVE STUDY OF THE BEHAVIOUR OF RADIOCAESIUM AND -STRONTIUM FROM DIFFERENT SOURCE TERMS IN PERMANENT PASTURES.

C.M. VANDECASTEELE, M. VAN HEES, C. HURTGEN and R. KIRCHMANN

CEN/SCK
Radiation Protection
Boeretang 200
B-2400 MOL

ABSTRACT

The behaviour of caesium and strontium deposited by the Chernobyl fallout in the region of Mol (Belgium) has been investigated in permanent pastures established on sandy soils. Their distribution within the soil and the changes of their concentration in grass were followed up to February 90. Their transfer from grass to cow's milk was investigated under field and controlled conditions. The behaviour of these two Chernobyl radionuclides is compared with that of the same nuclides from other source terms.

INTRODUCTION

In the region of Mol, the radioactive plume released from the damaged reactor in Chernobyl was detected on May 2. The peak of radioactivity in air was observed round about 11 a.m. on the same day. The radiocontamination in air decreased rapidly thereafter and was, on May 7, three orders of magnitude less than the peak concentration [2].

The highest deposits (more than 90% of the caesium and about 60% of the strontium deposit) were associated with rainfalls on May 3, 4 and 6. On May 10, the total fallout at Mol, in $\text{Bq}\cdot\text{m}^{-2}$, collected in stainless steel tanks, amounted to 35 for ^{90}Sr , 248 for ^{89}Sr , 1052 for ^{134}Cs and 2076 for ^{137}Cs [2]. Considering the residual contamination in our soils from weapons-testing fallout (WTF), respectively about 1.3 and 2.1 $\text{kBq}\cdot\text{m}^{-2}$ for ^{90}Sr and ^{137}Cs in spring 1986, the Chernobyl accident doubled the ^{137}Cs level in soil while it added but a few percent of ^{90}Sr to the still present pool.

RESULTS AND DISCUSSION

The interception of radiocaesium by grass on two pastures with mean fresh herbage densities of 1.4 and 0.3 $\text{kg}\cdot\text{m}^{-2}$, averaged over three samples collected on May 5 and 6, was respectively 22% and 13%. These values are in the range of that obtained for ionic forms under controlled conditions [3]. The interception of ^{89}Sr was estimated on one sample collected on May 6 and amounted to about 23% (herbage density = 1.7 kg

fresh weight.m⁻²). Taking into account the ratio ⁸⁹Sr/⁹⁰Sr in the deposit (7.1), one can estimate that 82% of the ⁹⁰Sr activity in this grass was due to the Chernobyl fallout while 18% originated from the old WTF deposit.

The changes over four years of the ¹³⁴-¹³⁷Cs contents in grass could be described by a two-compartments model. The ecological half-time estimated for the first compartment is about 10 days, while that of the long-term component is about 2 years. Because of the much lower amount deposited, the evolution of the ⁹⁰Sr concentration in herbage did not exhibit a clear exponential decrease like ¹³⁴-¹³⁷Cs. But systematic increases of the ⁹⁰Sr content were observed at each new start of vegetation growth after mowing (data not shown).

Six consecutive 5cm thick layers of our sandy soil were sampled at regular intervals in an ungrazed permanent pasture for radiocaesium and -strontium analyses [4]. Based on the ¹³⁷Cs/¹³⁴Cs ratio (1.8) in the Chernobyl deposit, the contribution of the WTF to the overall concentration in the different layers could be distinguished from that of Chernobyl. The concentrations averaged over 6 samples taken between May 13 and July 28 are given in table I.

SOIL LAYER (cm)	⁹⁰ Sr	¹³⁴ Cs	¹³⁷ Cs total	¹³⁷ Cs Chernobyl	¹³⁷ Cs WTF
0- 5	302 ± 13	1414 ± 311	3638 ± 525	2606	1032
5-10	284 ± 136	≤ DL	917 ± 310	na	917
10-15	157 ± 62	≤ DL	233 ± 86	na	233
15-20	≤ 85 ± 44	≤ DL	≤ 81 ± 22	na	≤ 81
20-25	≤ 89 ± 62	≤ DL	≤ DL	na	na
25-30	≤ 98 ± 58	≤ DL	≤ DL	na	na

DL = detection limit (≈ 65 Bq.m⁻²) ; na = not applicable.

Table I. Distribution of ⁹⁰Sr and ¹³⁴-¹³⁷Cs in the sandy soil of a permanent pasture (in Bq.m⁻² ± std. dev.).

During the first months after the accident, all ¹³⁴Cs in the soil remained confined in the top layer (mat horizon). Even four years later (data not shown), no migration to deeper layers could be observed. Most of the ¹³⁷Cs was also present in the mat horizon (72% from the Chernobyl fallout and 28% imputable to the WTF), but it was found deeper too, at least in the two next layers (up to -15 cm), due to the slow migration of the activity deposited in the sixties. Similar inference was not possible for strontium since when the samples were processed for strontium analysis, the ⁹⁰Sr had already decayed below its detection limit. However, as the contribution of the Chernobyl ⁹⁰Sr is less than 12% of the cumulated activity in the mat, the picture presented

corresponds essentially to the distribution of the strontium from the sixties. The sum of the ^{137}Cs activities attributed to the WTF in the different soil layers ($2.2 \text{ kBq}\cdot\text{m}^{-2}$) corresponds quite well to the amount expected to be still there from that source term while the sum of the ^{90}Sr activities represents but about 60% of the expected value. This can be explained by the higher mobility of strontium in soils, compared to caesium, leading to a higher exportation by vegetation harvesting or by lixiviation with the soil water.

Cow's milk is a good bio-indicator that integrates the upstream variations of the environmental behaviour of the radionuclides. Milk transfer factors (F_m) for the Chernobyl radiocaesium were estimated both under field and controlled conditions [5]. A value of $1.2 \cdot 10^{-2} \text{ d}\cdot\text{l}^{-1}$ was derived for freely grazing cows in the period between May and July 1986. A controlled experiment with cows fed over 30 days with hay harvested in June 1986 or in 1987 provided F_m values of $6 \cdot 10^{-3}$ and $1.1 \cdot 10^{-2} \text{ d}\cdot\text{l}^{-1}$ for the two respective harvests. The F_m estimated for strontium in field in May 1986 amounted to $1.6 \cdot 10^{-3}$ and $1.3 \cdot 10^{-3} \text{ d}\cdot\text{l}^{-1}$ for ^{90}Sr and ^{89}Sr respectively. A mean value of $1.7 \cdot 10^{-3} \text{ d}\cdot\text{l}^{-1}$ for ^{90}Sr has been estimated, still in field, for the period from June to September 1986. These transfer factors to milk, based on measurements performed in the region of Mol, are comprised in the range of the values reviewed by Coughtrey [1] for two other source terms (table II).

SOURCE TERM	CAESIUM	STRONTIUM
Chernobyl (pasture)	12 [5]	1.3 - 1.7 [this paper]
" (hay 86)	6 [5]	
" (hay 87)	11 [5]	
tracers studies	2 - 27 [1]	0.4 - 3.8 [1]
weapons testing	1.7 - 20 [1]	0.5 - 2.4 [1]

Table II. Transfer coefficients (F_m in $10^{-3} \text{ d}\cdot\text{l}^{-1}$) to cow's milk for radiocaesium and radiostrontium from different source terms.

CONCLUSION

The data obtained on the behaviour of the Chernobyl radiocaesium and -strontium in pasture ecosystems in the Mol region do not differ significantly from the data gathered in the past for these nuclides, from the WTF or used as ionic tracers. This suggests that most of the caesium and strontium from Chernobyl deposited in our region was readily soluble and largely available for plant and animal uptake.

BIBLIOGRAPHY

- [1] Coughtrey P.J., 1989, Radioactivity transfer to animal products, ANS-Report n° 2223-R1, Associated Nuclear Services Ltd, Epsom (UK), November 1989.
- [2] Deworm J.-P., 1987, A compendium of the measurements related to the Chernobyl nuclear accident, BLG-595, CEN/SCK, Mol (Belgium), 123pp.
- [3] Kirchmann R., Fagniat E. and Van Puymbroeck S., 1966, Studies on foliar contamination by radiocaesium and radiostrontium, in "Radiological concentration processes", Pergamon Press, Oxford - New-York : 475-483.
- [4] Vandecasteele C.M., Fagniat E., Colard J., Culot J.-P. and Kirchmann R., 1988, Transfer of radiocaesium deposited after the Chernobyl accident to agricultural plants, in "Impact des accidents d'origine nucléaire sur l'environnement", Vol. I, CEA/IPSN/SERE, Cadarache (France) : D179-D187.
- [5] Vankerkom J., Van Hees M., Vandecasteele C.M., Colard J., Culot J.-P. and Kirchmann R., 1988, Transfer to farm animals (ruminants) and their products of Cs-134, Cs-137 and I-131 after the Chernobyl accident, in "Impact des accidents d'origine nucléaire sur l'environnement", Vol. II, CEA/IPSN/SERE, Cadarache (France) : E111-E119.

A COMPUTER MODEL FOR THE CALCULATION OF DERIVED EMISSION LIMITS FOR
THE NORMAL OPERATION OF NUCLEAR FACILITIES

Bertrand Thériault

Atomic Energy Control Board
270 Albert St, Ottawa, Ont. Canada, K1P5S9

This paper presents a computer program for calculating derived emission limits for the normal operation of nuclear facilities. The environmental transfer model is discussed, in particular plume depletion effects, the effective height of release, sensitivity analysis, and the importance of the atmosphere to surface water pathway. When the receiving body of water receives only airborne effluent, this pathway has been found to be significant for long lived radionuclides and H₂O.

INTRODUCTION:

In order to ensure that no member of the public receives a dose higher than the regulatory limit, upper limits to the rate of release of radionuclides to the atmosphere and to surface waters must be known. This paper presents an overview of the computer program "DELPro" which has been developed to calculate such upper limits, usually known as derived emission limits (DEL), for the normal operation of nuclear facilities.

This paper is subdivided in two main sections. First, the methodology for calculating DELs is examined. The environmental transfer model (ETM), its applicability to other nuclear facilities as well as its limitations are discussed. In a second section, the program per se is described briefly, giving particular attention to modifications brought to the ETM¹; ie, the inclusion of atmospheric plume depletion effects, effects of building entrainment, and the addition of the atmosphere to surface water pathway. The sensitivity analysis routine is also discussed in this section.

METHODOLOGY:

The DEL is defined as the rate of release which is such that the group of maximally exposed individuals, the critical group, will not receive a dose higher than the regulatory dose limit. The critical group must also be relatively homogeneous with respect to those factors which affect doses received (eg, diet, age, behaviour). The methodology for determining DELs has three parts. First, the behaviour of the release must be known. Two modes of release are considered in the model¹; atmospheric and aquatic. A gaussian plume model is used for describing releases to the atmosphere. It assumes continuous release of radioactive material. A model² for reduction of the effective height of release due to plume entrainment in the wake of neighbouring buildings (downdraught) and in the wake of the stack itself (downwash) has been added to the initial model¹. Also added to the initial model is the effect of plume depletion (wet and dry deposition)^{2,3}.

Due to the high complexity of liquid dispersion in large bodies of water and its dependence on site-specific characteristics (eg, bottom topography, wind induced currents, seasonal variations in water

temperature) no general aquatic dilution model is used. Instead, site-specific concentrations are used. Also, since a DEL is calculated for each radionuclide released, the composition of the release must be known. This is achieved through effluent monitoring.

Second, the passage of radioactive material from the source through the environment to man must be analyzed. The environmental transfer model (ETM) used for this purpose is presented by the Canadian Standards Association¹, and can be seen in figure 1. Each compartment in the ETM is numbered. The quantity of radioactive material in compartment i is denoted X_i . A transfer parameter P_{ij} characterizes the transfer of material from compartment i to a compartment j such that

$$X_j = \sum_i P_{ij} X_i \quad (1)$$

All P_{ij} assume the system (ETM) to be in steady state, and are preferably calculated from site-specific data rather than from Canadian averages.

Figure 1: Environmental Transfer Model:

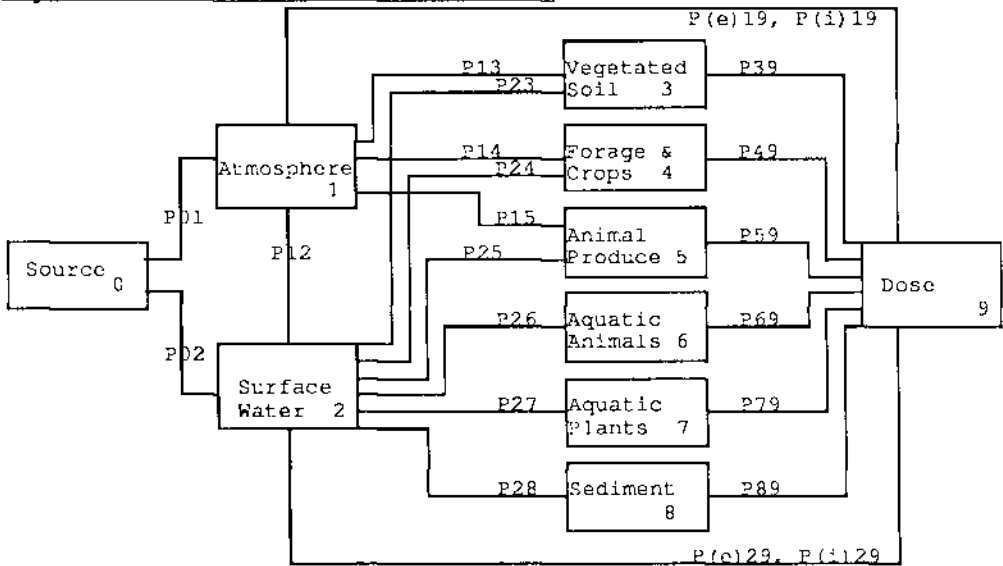

The atmosphere to water pathway (P_{12}) is not included in CSA¹ but it is in the Gorman⁴ model. In fig.1 the atmosphere to dose (P_{19}) and surface to dose (P_{29}) pathways both have two components. The external exposure component is denoted by (e) and the inhalation/ingestion component by (i). The DEL is defined as:

$$DEL = ADL / (X_9 / X_0) \quad (2)$$

where ADL is the annual dose limit for members of the public. DELs must be calculated separately for the stochastic and deterministic

dose limits, the most restrictive value being retained as the DEL for that radionuclide. X_g/X_c is determined from equation 1, for the pathways and radionuclides significant to the critical group in question. To ensure that the critical group is not exposed beyond the ADL, for a multi-facility site, when more than one radionuclide is released, or when more than one mode of release exists (air or water), the following criterion must be satisfied:

$$\sum_i \sum_j \sum_k Q_{ijk} / DEL_{ijk} \leq 1 \quad (3)$$

where Q_{ijk} is the actual release of radionuclide i from release mode j (air or water), and source facility k ; DEL_{ijk} is the DEL for radionuclide i , release mode j , and facility k .

The model applies to many facilities such as research reactors, incinerators, and radioisotope-processing facilities. The model does not apply to facilities involving area sources and releases to the ground (eg, uranium mine tailings and mills, fuel fabrication plants and refineries, and in-ground waste storage facilities).

THE PROGRAM:

DELPro is a 207 KB Microsoft Excel macro which can run on PC or MAC type microcomputers. It uses pull down menus to select actions (eg, select emission type, etc...) and dialogue boxes allow the user to enter site-specific information about the critical group. Doses to the critical group may also be calculated. Results of the calculations can be saved and printed.

When released from a stack, some of the material may be drawn downward into the low pressure region on the lee side of the stack. This process, known as downwash, causes the height of release to be lower than the stack height. This effect is usually present when the efflux velocity is similar or smaller than the mean windspeed at the stack height^{2,4}. The effective stack height may be further reduced if the emitted material is entrained in the wake of a nearby building. This effect, known as downdraught, occurs when the downwash corrected stack height is between 1 and 2.5 times the height of the nearby building, and when the mean windspeed is above 5 m/s^(2, 4).

Although the air to water pathway (P_{12}) is negligible when the receiving body of water also receives liquid emissions⁴, it may be important when radioactive material deposits onto standing ponds. These land ponds, receiving no liquid emissions, may be used for irrigation of crops and/or drinking water for livestock. To examine the importance of P_{12} , DELs were calculated using Canadian averages for all transfer parameters, with all realistic pathways selected. DELs for about 31 out of a total of 78 radionuclides decreased by a factor of two or more when P_{12} was selected. The most significant decrease was for ²³⁸U; when the pond was used for drinking by livestock the ²³⁸U DEL went down 9 orders of magnitude. Such a decrease was predictable since P_{12} is proportional to the half-life of the radionuclide¹ (²³⁸U half-life = 4.5E+9 years). The DEL for HTO went down by a factor of 6. A sensitivity analysis has shown that the atmosphere-pond-livestock-man pathway contributes 99% of the dose to

man for ^{135}Cs , ^{234}U , ^{235}U , ^{238}U , ^{237}Np , and ^{244}Pu when all airborne emission pathways are present. This same pathway contributed 79% of the dose for HTO.

The effect of dry deposition on plume depletion is accounted for by multiplying the atmospheric dispersion coefficient by the ratio of concentration of activity in the air taking into account dry deposition to the concentration of activity ignoring deposition³. Dry deposition reduces plume concentration significantly in stable conditions and at long distances from the source ($> 10\text{km}$). To account for wet deposition the atmospheric dispersion coefficient is multiplied by the factor $e^{-\Lambda t_1}$. Values of the washout coefficient, Λ , for rain and snow, and for various precipitation rates are suggested in reference 2; t_1 is the time during which the plume is being depleted by precipitation.

Each pathway's contribution, C_{ijk} , to the critical group dose is evaluated for each pathway i , radiation effect j (eg, stochastic dose to adults), and radionuclide k , and can be written as:

$$C_{ijk} = (X_9/X_0)_{ijk} / \sum_n (X_9/X_0)_{njk} \quad (4)$$

where m is the total number of significant pathways, $1 \leq n \leq m$, and X_0 and X_9 are from equation (2).

CONCLUSION:

The addition of the air to water pathway, accounting for downdraught and downwash, and the inclusion of plume depletion effects increase the versatility of DELPro. The next task now is to obtain a better understanding of the uncertainties associated with DELs and doses calculated using this model. Also, increasing the processing speed of the program by upgrading it to a compiled version would make it easier to run complex simulations.

REFERENCES:

1. Canadian Standards Association, "Guidelines for Calculating Derived Emission Limits for the Radioactive Material in Airborne and Liquid Effluents for Normal Operation of Nuclear Facilities", CSA/CSA N288.1, August 1987.
2. Canadian Standards Association, "Guidelines for Calculating Radiation Doses to the Public from a Release of Airborne Radioactive Material under Hypothetical Accident Conditions in Nuclear Reactors", CAN/CSA N288.2, September 1989.
3. Jones, J.A., "A Procedure to Include Deposition in the Model for Short and Medium Range Atmospheric Dispersion of Radionuclides", NRPB-R122, 1981 (London, HMSO)
4. Gorman, D.J., "The Basis for the Derived Limits for the Emission of Radionuclides in Airborne and Liquid Effluents from Ontario Hydro's Nuclear Facilities", SSD-HSD-86-3, 1986
5. Pasquill, F., "Atmospheric Diffusion", Van Nostrand, London, 1962

PRESENTATION AND INTERPRETATION OF FIELD EXPERIMENTS OF
GASEOUS UF₆ RELEASES IN THE ATMOSPHERE

B. CRABOL, D. BOULAUD, G. DEVILLE-CAVELIN
CEA / INSTITUT DE PROTECTION ET DE SURETE NUCLEAIRE
Département de Protection de l'Environnement et des
Installations

BP 6 92265 Fontenay-Aux-Roses Cédex FRANCE

C. GEISSE, L. IACONA
EURODIF / PRODUCTION
Site de Tricastin

BP 175 26702 Pierrelatte Cédex FRANCE

ABSTRACT

An experimental programme concerning the behaviour of UF₆ released in gaseous phase in the atmosphere has been conducted in the years 1986-1989 by the french Atomic Energy Commission and Eurodif. Three field tests have been performed on the CEA/CESTA experimental site. These experiments permitted to get informations about the kinetics of the hydrolysis reaction of the UF₆, the behaviour of the hydrolysis products in the atmosphere and the granulometry of the solid particles.

RESUME

Un programme d'expérimentation sur site a été mené entre 1986 et 1989 par le Commissariat à l'Energie Atomique et Eurodif afin de mieux évaluer les risques pour l'environnement auxquels conduirait un rejet accidentel d'UF₆ sous forme gazeuse dans l'atmosphère. Trois essais ont été réalisés sur le terrain d'expérimentation extérieur du CEA/CESTA. Ces essais ont permis d'obtenir des informations sur la cinétique de la réaction d'hydrolyse de l'UF₆, sur la diffusion des produits d'hydrolyse dans l'atmosphère et la granulométrie des particules formées.

1. Introduction

The UF₆, used in the nuclear fuel processing, reacts with the water vapour of the air to give a solid product UO₂F₂ and a toxic gas, HF:

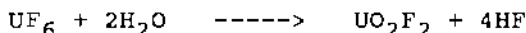

The numerical prediction of the consequences of an accidental release of UF₆ in the atmosphere needs therefore the following points to be considered :

- . what is the kinetics of the hydrolysis reaction,
- . how do UO₂F₂ and HF diffuse in the air, what are their chemical-physical forms and how do they deposit on the ground.

In order to answer to these questions, EURODIF, the operator of the uranium enrichment plant of Tricastin in the Rhône Valley, and the Institute for Protection and Nuclear Safety of the CEA, in cooperation with the U.S. Department of Energy (D.O.E.), decided some years ago to undertake an in-field experimental programme on UF_6 atmospheric dispersion. Three releases of gaseous UF_6 have been accomplished in 1986, 1987 and 1989 on the CEA/CESTA test site, near Bordeaux. This paper summarizes the main results obtained in these experiments.

2. Results and interpretation

2.1 - Concentrations in the atmosphere

The figure 1 presents the maximum values of the Atmospheric Transfer Coefficient (ATC, i.e., the ratio of the time integrated concentration at a given point over the released quantity) versus distance. It is observed that the ATC values in U and F are very close to each other. On the same figure, are also reported the SF_6 results (SF_6 is used in these experiments as a reference tracer). It can be observed that these values are very near to the previous ones, except at short distance from the source (it is difficult to attribute this discrepancy to a particular behaviour of the UF_6 plume in the first meters or only to the differences, even small, in the release conditions). It can be concluded that U and F diffuse similarly, and diffuse like a passive contaminant. Particularly, a major finding of these experiments is that no detectable depletion of the aerosols of UO_2F_2 in the plume due to the ground deposition occurs.

For analysis of the kinetics of the hydrolysis reaction, the atmospheric concentrations of U trapped on the particle filters in the first test have been measured : they were found to be close to the values collected at the same points in the bubblers, meaning that, after some seconds of travel time, all uranium was in form of particles UO_2F_2 and that the hydrolysis reaction had already ended. A confirmation of this fact is brought hereafter.

2.2 - Ground deposition

The figure 2 presents the deposition velocity of the uranium versus distance, on the points where the measured atmospheric concentrations were maximum on each cross-section. In both experiments, the velocity lies between 10^{-4} and 4.10^{-4} ms^{-1} , in good agreement with the sedimentation velocity which can be expected according to the measured particle sizes (see § 2.3). The velocity does not increase with the distance (on the contrary, it decreases), confirming that the hydrolysis is complete after a few seconds : if it was not the case, the creation of particles of UO_2F_2 during the transfer would increase the deposition velocity.

The mass ratio U/F measured in the deposits is presented on the figure 3 for the points in the wind axis. In the second test, this ratio is near by 6.3, which is the theoretical ratio in the UO_2F_2 compound. It means that only UO_2F_2 deposits on the ground, and indicates that no mixed compound UO_2F_2, HF is present in significant proportion in the plume. However, in the third test, a lower ratio is observed, particularly at distances greater than 40 m. These measurements do not seem significant as sand was found in important quantity in several of the Petri boxes where samples were collected, disturbing the analysis (a clear correlation is observed between the boxes where sand was found and the low value of the ratio). The sand could be easily transported by the wind due to the relatively low air humidity during this experiment.

2.3 - Granulometry

The granulometric distribution (aerodynamic diameters) in uranium is presented on the figure 4. The results in both experiments are very similar : they show a major mass fraction between 1 and 3 μm at all distances. Moreover, the distributions in F is very comparable to the one in U (which is not a surprise according to the preceding results concerning the solid compound formed during the transfer).

3. Conclusion

The experimental programme carried out in France in the years 1986-1989 allowed to get several important informations on the behaviour of UF_6 released in gaseous phase in the atmosphere :

- the hydrolysis reaction of the UF_6 is rapid, probably complete after some seconds;
- U and F diffuse similarly, without significant differences compared to the reference tracer;
- only, UO_2F_2 aerosols deposit on the ground;
- the major mass fraction of aerosols is observed for aerodynamic diameters between 1 and 3 μm ;
- the deposition velocity of the aerosols lies between 1 and $4.10^{-4} ms^{-1}$, values which are coherent with the expected sedimentation velocity for such particles.

Care must be taken not to extrapolate without caution all these conclusions to the cases of UF_6 released in liquid phase, for which, as it has been observed in different incidents, other and more complex phenomena may occur.

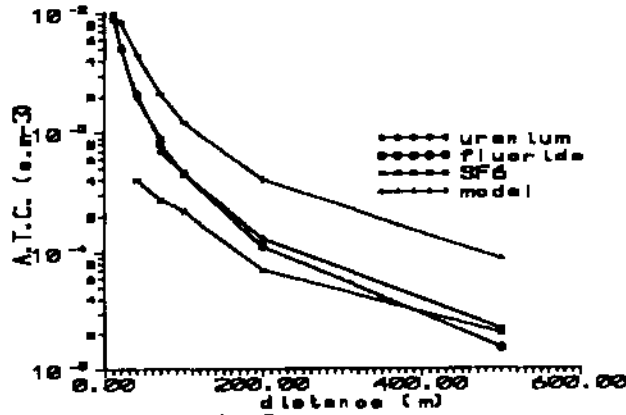

Figure 1. Second experiment. Atmospheric Transfer Coefficient in the wind axis versus distance

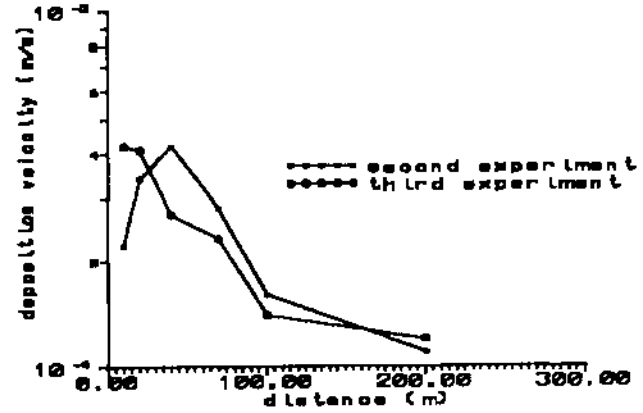

Figure 2. Deposition velocity of uranium in the wind axis

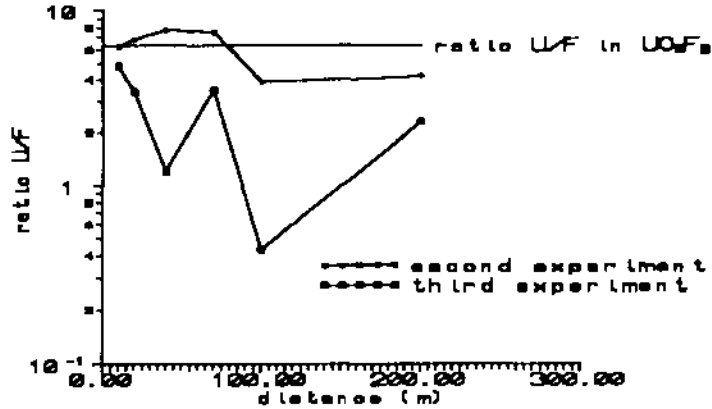

Figure 3. Mass ratio U/F in the ground deposit (wind axis)

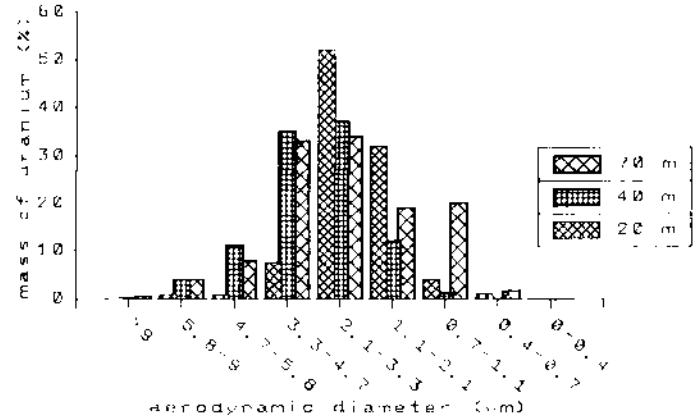

Figure 4. Second experiment. Distribution of the granulometry of the uranium

ETUDE EXPERIMENTALE DE LA REPARTITION ENTRE SOL ET PLANTES DES DEPOTS
D'AEROSOLS ATMOSPHERIQUES MICRONIQUES.

H. Camus, D. Gauthier, C. Caput, C. Soyser et R. Escarriot

CEA / Institut de Protection et de Sureté Nucléaire,
Département de Protection de l'Environnement et des Installations,
Centre d'Etudes Nucléaires de Fontenay-Aux-Roses,
BP N° 6, 92265 Fontenay-Aux-Roses Cedex

EXPERIMENTAL STUDIES ABOUT THE DISTRIBUTION BETWEEN SOIL AND CROPS
OF SMALL PARTICLES FALLOUT.

These studies are performed to quantify the distribution between soil and crops of the micronic particles generated during a major accidental release. Works are done in open fields. We have chosen the size of the particles to simulate the situation of the environment like in the not immediately near field. The results are very dispersed, function of the vegetals types and of the season.

At first, we expose some generalities about the experimental techniques; then the results and finally we comment and specify the limits of use of that kind of data.

INTRODUCTION

Nous présentons ici l'état récapitulatif des travaux entrepris par l'Institut de Protection et de Sureté Nucléaire dans le cadre du programme RESSAC¹ et relatifs à la répartition du dépôt entre le sol et la végétation cultivée sus-jacente.

L'expérimentation se subdivise en une phase de marquage des parcelles cultivées par un aérosol micronique; puis en une phase d'analyse du marqueur déposé sur les végétaux et les surfaces de sol correspondantes.

Nous présenterons en premier lieu les grandes lignes des techniques expérimentales employées, puis les résultats obtenus. Enfin, nous commenterons et indiquerons les principales conclusions et limites dans lesquelles il convient d'employer ces données.

1: MATERIELS ET METHODES

1-1: L'AEROSOL

La granularité doit être comparable à celle de l'aérosol de Tchernobyl. La substance active doit être facilement mesurable, non-toxique et de désactivation rapide (nécessité de pouvoir réutiliser rapidement le site d'essais).

Le produit qui nous est apparu comme le plus approprié a été l'uranine en solution aqueuse à 25 g.l⁻¹, dispersable à partir d'un générateur ultra-sonique à fort débit (5 l.h⁻¹), et mesurable avec une sensibilité satisfaisante par fluorimétrie (10⁻⁷ g.l⁻¹).

L'aérosol produit présente un diamètre median en masse de 1,5 µm avec un écart-type géométrique de 2,2.

¹ Réhabilitation des Soils et des Surfaces après un Accident.

1-2: LE MARQAGE

Les essais conduits dans le cadre de ce programme n'ont concerné que le dépôt sec.

Le dispositif consiste à disposer les générateurs d'aérosol dans le vent des parcelles cultivées, et de les déplacer le long de celles-ci à l'aide d'un chariot mobile.

Les essais ainsi réalisés ont permis d'obtenir une homogénéité verticale de concentration dans les trois premiers mètres au dessus du sol, à condition toutefois que le générateur soit placé à un minimum de trente mètres en amont au vent des cultures.

GRADIENTS VERTICAUX DE CONCENTRATION

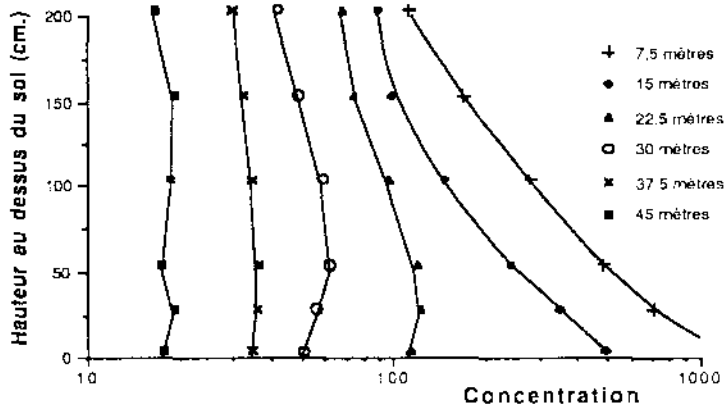

GRANULOMETRIE DE L'AEROSOL D'URANINE

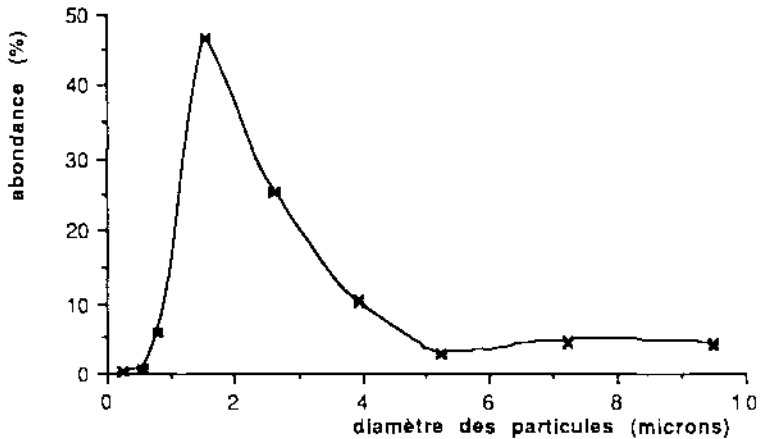

1-3: LES PRELEVEMENTS

L'évaluation du dépôt sur la végétation se fait à partir de plantes entières.

L'évaluation du dépôt au sol est réalisée à partir de jauges de dépôt (disques d'acier inoxydable, $\Phi = 20$ cm, déposés directement sur le terrain. Cette méthode présente l'avantage de permettre la mesure de l'uramine avec un rendement proche de l'unité. Une mesure effectuée à partir d'échantillons de terre a un rendement fluctuant entre 0,4 et 0,6, imprévisible a priori, et est donc inutilisable dans notre cas. Des essais préalables nous ont permis d'établir que le dépôt sur nos jauges était représentatif du dépôt sur sol cultivé. Les échantillons sont lavés dans une quantité connue de solution tampon (pH 9,4), filtrés à 0,45 μm et finalement mesurés par fluorescence (513 nm).

1-4: LES VEGETAUX ETUDIES

Nous avons déterminé l'ensemble des cultures les plus abondantes en surface dans les pays européens. Nous avons étudié: des céréales (blé et maïs), des plantes oléagineuses (colza et tournesol), des plantes textiles (lin), maraichères (épinards, salades), des légumes industriels (petits pois, haricots, pommes de terre) et des plantes fourragères (betteraves, luzerne et graminées).

2: RESULTATS & INTERPRETATION

Le tableau proposé en fin de ce texte présente l'ensemble des résultats obtenus, en fonction de la productivité (poids sec par mètre carré de culture) ou du stade végétatif des plantes. Remarquons que ces deux indications sont complémentaires: le stade végétatif ne donne pas une indication suffisamment précise, et les résultats sont très influencés par les différences morphologiques entre les variétés. La productivité est souvent fonction de la densité de semis et aussi de la variété étudiée.

Pour certaines espèces, nous disposons de résultats suffisamment nombreux et homogènes pour tracer les courbes d'évolution du coefficient de captation des plantes en fonction de la productivité.

Nous ajustons les courbes de points à des courbes de la forme

$$y = ax^b.$$

Elles sont toujours bien corrélées avec le nuage des points expérimentaux, mais peuvent théoriquement donner des résultats de captation supérieurs à 100%...si on les emploie sans discernement hors de leur région de validation.

VEGETAUX	a	b
BLE (PAILLES COURTES)	26,22	0,12
BLE (PAILLES LONGUES)	15,62	0,215
CROU	1,60	0,48
HARICOT & POIS	4,09	0,41
HERBE	1,53	0,57
LIN	6,16	0,36
LUZERNE	17,56	0,21
MAIS	10,01	0,25
POMME DE TERRE	2,56	0,46
TOURNESOL	5,22	0,33

La figure ci-après illustre ce type de résultat.

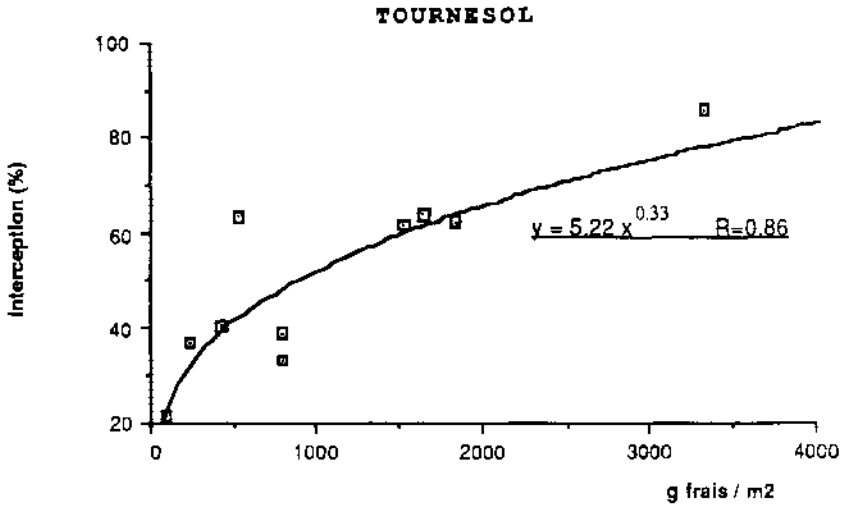

Les données obtenues montrent de nettes variations dans le coefficient de captation, fonctions de l'espèce, du stade végétatif et de la densité culturale. En cas d'accident, on ne peut donc pas se satisfaire d'une seule courbe pour l'estimation des conséquences radiologiques et des mesures de protection à décider. Il faut pouvoir tenir compte des spécificités dues aux espèces cultivées, à leur stade de développement et aux pratiques culturales locales. Les données acquises lors de ces essais sont utilisables dans ce cadre.

EXEMPLE DE TABLEAU DE RESULTATS

VEGETAL	STADE	RENDEMENT		REPARTITION		VEGETAL	STADE	RENDEMENT		REPARTITION	
		g/m2 sec	g/m2 frais	%	±			g/m2 sec	g/m2 frais	%	±
blé	A	130	350	53,0	16,4	prairie	B	492	1 171	73,0	40,5
blé	A/B	96	689	74,8	3,8	prairie	C	238	626	72,1	5,0
blé	A/B	646	2 585	70,7	5,0	prairie	C	205	930	73,4	5,7
blé	B	684	2 780	66,0	34,9	prairie	D	354	715	87,5	1,9
blé	B/C	323	1 747	74,6	2,9	prairie	D	166	411	38,5	6,4
blé	C	304	460	40,0	16,7	prairie	D	238	832	99,1	0,4
blé	C	837	1 690	67,0	3,6	prairie	D	507	1 802	92,1	2,6
blé	C	1062	4 000	58,3	3,8	fétuque	C	283	1 017	89,1	2,4
blé	C	1353	4 090	70,1	4,3	fétuque	B	192	659	73,5	4,2
blé	C	963	5 157	76,0	1,7						
blé	C/D	1502	2 610	79,5	6,4	maïs	A	97	649	60,6	6,1
blé	D	1017	1 284	78,3	4,2	maïs	A	42	283	40,9	6,5
blé	D	1340	1 460	80,5	2,2	maïs	B	47	319	10,5	6,1
blé	D	1228	2 738	66,0	32,0	maïs	B	212	1 610	47,2	4,6
						maïs	B/C	432	1 790	76,0	2,8
lin	B	113	738	59,7	14,4	maïs	C	637	4 240	90,5	19,7
lin	C	71	296	71,8	6,3	maïs	D	1666	4 200	83,8	5,8

LEGENDE (stades végétatifs):

A: semis ou repiquage; B: montaison ou élongation cellulaire;
C: floraison; D: maturité commerciale ou fructification.

HIGH TEMPERATURE PEAK CHARACTERISTICS OF THE READER-ANNEALED TLD-600
AND ITS APPLICATION TO PERSONNEL PROTECTION DOSIMETRY
IN MIXED NEUTRON-PHOTON FIELD

James C. Liu

Stanford Linear Accelerator Center, Stanford, CA 94309, USA

C. S. Sims

Oak Ridge National Laboratory, Oak Ridge, TN 37831-6379, USA

ABSTRACT

The high temperature peaks 6-7 of TLD-600 have higher responses to high LET radiation than to low LET radiation. This characteristic was studied for the automatic reader-annealed Harshaw albedo neutron TLD. The high temperature peaks response is linear for neutrons, but is supralinear above 20 mSv of ^{137}Cs photons. The peaks ratio (peaks 6-7/peaks 3-5) of TLD-600 is 0.15 for neutrons of any energy, 0.01 for ^{137}Cs gammas and 0.02 for M-150 x-rays. Based on the results, a personnel dosimetry using a single TLD-600 was developed and evaluated in mixed neutron-photon fields. The estimations for neutron, photon and total equivalent are better than 20% except in one case. However, an error analysis shows that the estimations are sensitive to the neutron and photon peaks ratios, depending on the neutron-photon dose equivalent ratio and the neutron source.

INTRODUCTION

The TL glow curve of the LiF-TLD (TLD-100, TLD-700, TLD-600) has several peaks, among which peaks 3-5 are main dosimetric peaks (peak 5 at $\sim 200^\circ\text{C}$), and peaks 6-7 are high temperature peaks (peak 7 at $\sim 260^\circ\text{C}$). Other peaks are usually not important for dosimetric purposes. The high temperature peaks have higher responses to high LET radiation than to low LET radiation and this characteristics can be influenced by many factors, e.g., TLD material, annealing, cooling, readout method, etc. Conventional long and high temperature oven annealing for LiF-TLD is usually not used for automatic TLD systems. This paper presents the high temperature peak characterization results for the Harshaw automatic reader-annealed TLD-600. Based on the results, a mixed field neutron-photon dosimetry using a single TLD-600 element was developed and evaluated in mixed fields. A few factors which may affect the accuracy of the dosimetric method are discussed.

MATERIALS AND METHODS

Harshaw albedo neutron TLDs (two pair of TLD-600/TLD-700; one pair is shielded in front by a $28 \times 13 \times 0.46 \text{ mm}^3$ cadmium sheet) were used in this study. The sensitivities of all TLD chips ($3.2 \times 3.2 \times 0.9 \text{ mm}^3$) were individually calibrated with free-in-air ^{137}Cs irradiations. The TL signals were normalized to a constant ^{137}Cs exposure and were in units of μGy . The Harshaw 8800 automatic TLD reader was used to readout and anneal the TLDs. The digitized 200-channel TL glow curves of the TLD-600 exposed to neutrons or photons from the Harshaw 8800 reader are shown in Figure 1. Neutrons produce much higher peaks 6-7 and slightly lower peaks 3-4 than photons. The linear heating profile (no preheat, a heating rate of 25°C s^{-1} from 50°C to 300°C , and a hold time of 6.7 s at 300°C) using hot N_2 gas in this study is also shown in Figure 1. The Computerized Glow Curve Deconvolution (CGCD) program⁽¹⁾ was used to separate the glow curve into individual peaks, but the deconvolution result was not satisfactory. This might be due to the first-order TL kinetic model in the CGCD program being inappropriate to describe the TL response of a neutron-exposed TLD-600.

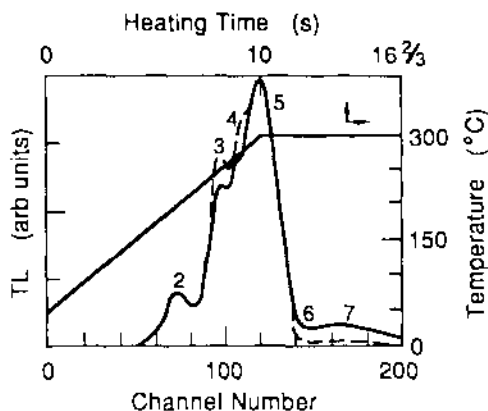

Figure 1. TL glow curves induced by neutrons (—) or photons (---) for TLD-600. Peaks 3-5 cover channels 96-145 and peaks 6-7 cover channels 146-200. The heating profile used is also shown.

Therefore, in this study (see Figure 1), the TL signal between channels 96-145 is regarded as peaks 3-5 and the TL signal between channels 146-200 is regarded as peaks 6-7. It has been found⁽²⁾ that these channel settings can achieve a satisfactory sensitivity and response stability over reuse, and minimize the fading influence from peaks 2 and 3. The TLDs were reader-annealed using the same heating profile just prior to irradiation. However, repeated annealings or annealing using a longer hold time (20 s) at 300°C was used sometimes for highly dosed TLDs in order to reduce the residual TL signal to an acceptable level. No pre-irradiation or post-irradiation, low temperature annealing was used.

Four radioisotopic neutron sources [²⁵²Cf(D₂O), ²⁵²Cf(PE), ²⁵²Cf and ²³⁸PuBe], eight monoenergetic neutrons (0.1, 0.25, 0.565, 1.2, 2.6, 3.2, 5.0 and 14.8 MeV), ¹³⁷Cs and the M150 x-rays were used for the TLD irradiations⁽³⁾. The ²⁵²Cf(PE) source is a ²⁵²Cf moderated by a 15 cm radius polyethylene sphere. The errors associated with neutron fluences were 10-15% for monoenergetic neutrons and 5-10% for radioisotopic neutron sources. All TLDs were irradiated perpendicularly with dosimeters mounted on the front face of a 40×40×15 cm³ Lucite phantom, except the M150 x-rays irradiations which were made using a 30×30×15 cm³ phantom. The dose equivalent quantity used is the ICRP 21 neutron dose equivalent quantity⁽⁴⁾ for neutrons and is the deep dose equivalent quantity⁽⁴⁾ for photons. The photon contribution from the neutron source to the TLD-600 signal was estimated by the paired TLD-700 element.

CHARACTERIZATION RESULTS

LINEARITY

The TL response for the Cd-covered TLD-600 exposed to ²⁵²Cf(PE) are shown in Figure 2. The linear response level for peaks 6-7 is up to ~2.56 mGy at 3 mSv neutron exposure. Since both peaks 6-7 and peaks 3-5 have linear responses over the range of 0.05-3 mSv, the total TL response (peaks 3-7 = the sum of peaks 3-5 and peaks 6-7) is also linear. The peaks ratio, peaks 6-7/peaks 3-5, is equal to the slope ratio in Figure 2. Therefore, the neutron peaks ratio for ²⁵²Cf(PE) is a constant of $(0.854/5.921)=0.144$ ($1\sigma=2\%$) over the dose range. The neutron sensitivity of the Cd-covered TLD-600, defined as the peaks 3-7 response, for ²⁵²Cf(PE) is $(0.854+5.921)=6.78$ mGy mSv⁻¹. Figure 3 shows the linear response curves of the Cd-covered

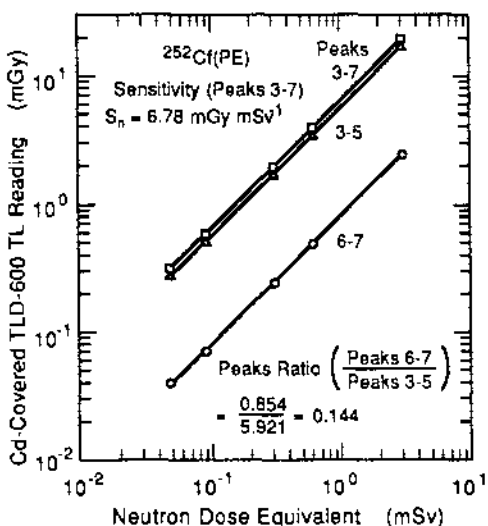

Figure 2. TL response linearities of the peaks 3-5, peaks 6-7, and total peaks 3-7 for the Cd-covered TLD-600 exposed to the $^{252}\text{Cf(PE)}$ neutrons.

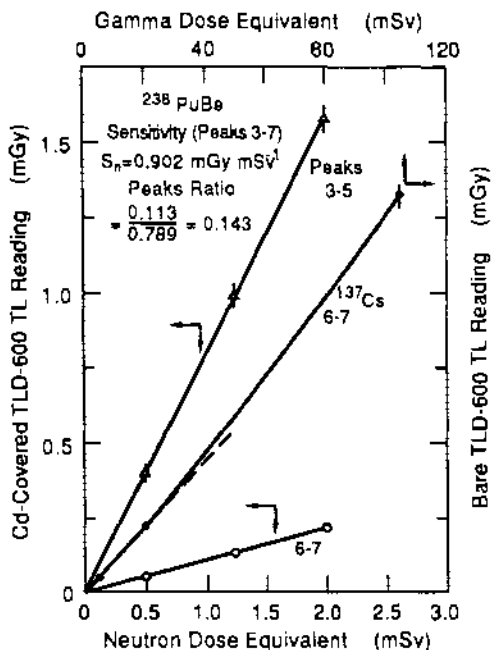

Figure 3. TL response linearities of the peaks 3-5 and peaks 6-7 for the Cd-covered TLD-600 exposed to $^{238}\text{PuBe}$ neutrons. The supralinearity of the peaks 6-7 response for bare TLD-600 exposed to ^{137}Cs photons is also shown.

TLD-600 for $^{238}\text{PuBe}$. The neutron peaks ratio is $(0.113/0.789)=0.143$ ($1\sigma=3\%$), which is very close to that of $^{252}\text{Cf(PE)}$, but the neutron sensitivity is only $(0.113+0.789)=0.902$ mGy mSv^{-1} , due to the albedo neutron detection principle.

Figure 3 also shows the peaks 6-7 response of the bare TLD-600 exposed to ^{137}Cs free-in-air. The linear response level for peaks 6-7 is up to only 0.23 mGy at 20 mSv gamma exposure and the linear region has a slope of 0.012 mGy mSv^{-1} . The deviation from linearity (see dashed line in Figure 3) is $\sim 15\%$ overresponse at 103 mSv. The peaks 3-5 response of the TLD-600 exposed to ^{137}Cs , which is not shown in Figure 3, is linear up to 100 mSv with a slope of 1.045 mGy mSv^{-1} . Therefore, the photon peaks ratio of the TLD-600 for ^{137}Cs is a constant of $(0.012/1.045)=0.01$ ($1\sigma=10\%$) only up to the level of 20 mSv, due to the supralinear response of peaks 6-7.

Since the peaks 6-7 response is only $\sim 1\%$ of the peaks 3-5 response for a gamma-exposed TLD-600, the supralinearity of peaks 6-7 response is masked by the linearity of peaks 3-5 response. Therefore, the total peaks 3-7 response for a gamma-exposed TLD-600 is treated as linear in most personnel protection dosimetric practices.

The finding that the supralinearity of peaks 6-7 is LET-dependent (the lower the LET, the lower the TL response level at which supralinearity occurs) is consistent with results previously reported in Refs. 5 and 6. However, the gamma dose levels at which the supralinearity occurs are

different between our results and others (~100 mGy for TLD-100 in Ref. 5, 2.5 mGy for TLD-700 in Ref. 6, and ~20 mGy for TLD-600 in this work). It is also demonstrated that the peaks 6-7 have a higher response to neutrons than to photons; a factor of $(0.113/0.012)=9.4$ between $^{238}\text{PuBe}$ and ^{137}Cs , and a factor of $(0.854/0.012)=71$ between $^{252}\text{Cf(PE)}$ and ^{137}Cs .

PEAKS RATIO AND SENSITIVITY

Since the Cd-covered TLD-600 responds mainly to the albedo thermal neutrons, the peaks ratio is expected to be the same for all incident neutron energies. The peaks ratios of the Cd-covered TLD-600 for the monoenergetic and radioisotopic neutron sources ranged from 0.143 to 0.163 and the mean neutron peaks ratio was 0.15 ($1\sigma=7\%$). The neutron sensitivity (S_n) follows the typical energy-dependent curve of an albedo-type TLD (the response is high at low energies and is low at high energies).

Contrary to the neutron results, the photon peaks ratio is energy-dependent; 0.01 ($1\sigma=10\%$) for ^{137}Cs 662 keV gammas and 0.02 ($1\sigma=3\%$) for M150 x-rays. The photon sensitivity (S_p) of the Cd-covered TLD-600 is slightly energy-dependent (0.872 mGy mSv $^{-1}$ for ^{137}Cs gammas and 0.916 mGy mSv $^{-1}$ for M150 x-rays), due to the tissue-equivalence of the TLD-600 to photons.

Budd et al.⁽⁷⁾ studied the peaks ratios of the TLD-600 to x-rays and their peaks ratio values are a factor of five higher than ours, probably due to the slow cooling they used. However, a comparison on the relative peaks ratio as a function of photon energy (the peaks ratio at a given energy divided by the peaks ratio for ^{137}Cs gammas) between their results and ours shows good agreement (see Figure 4). The peaks ratios for neutrons and photons in this work are close to those of Doles et al.⁽⁸⁾ who used TLD-100 with different readout and annealing techniques.

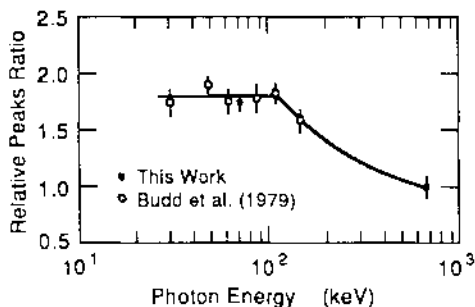

Figure 4. Relative peaks ratios as a function of photon energy (peaks ratio at a given energy divided by that of ^{137}Cs photons) for the Cd-covered TLD-600.

MIXED NEUTRON-PHOTON FIELD DOSIMETRY

A neutron-photon dosimetry using a single Cd-covered TLD-600 element in mixed fields can be developed by using the peaks ratio and sensitivity values. A Cd-covered TLD-600, irradiated to a neutron dose equivalent (H_n mSv) and a photon dose equivalent (H_p mSv), has a total peaks 3-7 signal of T mGy. Let the peaks ratio be PR (i.e., $PR = \text{peaks 6-7}/\text{peaks 3-5}$) and $K = PR/(1+PR)$ (i.e., $K = \text{peaks 6-7}/\text{peaks 3-7}$). The following two equations can be established.

$$T_H = H_n S_n K_n + H_p S_p K_p \quad (1)$$

$$T_I = H_n S_n (1 - K_n) + H_p S_p (1 - K_p) \quad (2)$$

T_H, T_I = measured peaks 6-7 and peaks 3-5 TL signals in units of mGy, respectively, and $T = T_H + T_I$

K_n, K_p = K values for neutron and photon radiations, respectively

S_n, S_p = neutron and photon sensitivities (peaks 3-7), respectively, of the Cd-covered TLD-600 in units of mGy mSv⁻¹

$H_n S_n K_n$ = TL signal component of peaks 6-7 contributed by neutrons.

Since PR is 0.15 for all neutrons, K_n is 0.13 for all neutrons. The value K_p is dependent on photon energy and can be determined from Figure 4. If neutron and photon energies are known, there are only two unknowns, H_n and H_p , to be solved in equations 1 and 2.

A test of the above mixed field dosimetry was made by irradiating eight groups of albedo TLDs to two neutron dose equivalents (0.5 and 1.5 mSv) with four H_n/H_p ratios (2.6/1, 1/1, 1/3 and 1/10), using both $^{238}\text{PuBe}$ and ^{137}Cs sources. The small 4.43 MeV gamma dose equivalent component (~4%) of the $^{238}\text{PuBe}$ source⁽³⁾ was included in the photon dose equivalent. The test results presented in Table 1 show the bias (B), precision (P) and accuracy (A) values in percentage for the neutron, photon and total (neutron + photon) dose equivalent estimations in eight mixed fields by using the four Cd-covered TLD-600 elements per exposure group.

Table 1. Dose equivalent measurement performance of the Cd-covered TLD-600 in mixed $^{238}\text{PuBe} + ^{137}\text{Cs}$ fields, using the high temperature peaks method.^(a) The values for B , P , and A are in percentage.

$H_n^{(b)}$	H_n/H_p	$H_p^{(b)}$	Neutron			Photon			Total ^(f)		
			$B^{(c)}$	$P^{(d)}$	$A^{(e)}$	B	P	A	B	P	A
0.5	2.6/1	0.19	-22.0	6.6	28.6	28.9	4.1	33.0	-7.2	3.3	10.5
	1/1	0.52	-14.0	3.3	17.3	7.7	3.0	10.7	-2.9	1.0	3.9
	1/3	1.52	-10.0	3.1	13.1	2.6	1.1	3.7	-0.5	1.3	1.8
	1/10	5.02	0	9.8	9.8	1.4	1.3	2.7	1.3	1.8	3.1
1.5	2.6/1	0.57	-12.0	5.9	17.9	7.0	6.2	13.2	-6.8	4.8	11.6
	1/1	1.57	-10.0	4.0	14.0	1.9	3.2	5.1	-3.9	2.7	6.6
	1/3	4.57	-7.3	3.5	10.8	1.3	1.6	2.9	-0.8	2.0	2.8
	1/10	15.07	4.0	4.3	8.3	-1.3	0.9	2.2	-0.9	1.1	2.0

(a) Peaks ratio is 0.15 for neutrons and 0.01 for ^{137}Cs photons.

(b) H_n is the neutron dose equivalent from $^{238}\text{PuBe}$, H_p is the photon dose equivalent from both ^{137}Cs and the 4.43 MeV gamma component of $^{238}\text{PuBe}$ (~4% of its neutron dose equivalent)⁽³⁾ in mSv units.

(c) Bias (B) is $(H - H_0)/H_0$, where H is the mean dose equivalent estimated from the four Cd-covered TLD-600 elements per exposure group and H_0 is the reference value.

(d) Precision (P) is one relative standard deviation per group.

(e) Accuracy (A) is the sum of the absolute value of bias and precision.

(f) Total dose equivalent (neutron + photon) estimation.

The neutron or photon bias is small when the H_n/H_p is small, and the bias is also smaller at the higher neutron dose equivalent level. The largest bias (-22% for neutrons and 29% for photons) occurs in the mixed field with $H_n = 0.5$ mSv and $H_n/H_p = 2.6/1$. The photon precision is better when the H_n/H_p is smaller (<7% in all cases). The neutron precision is better in the fields with $H_n/H_p = 1/1$ or $1/3$ (<10% in all cases).

Since the precision values are smaller than the corresponding bias values in most fields, the accuracy values show the same trend as the bias values. The worst accuracy is 29% for neutrons and 33% for photons in the field of $H_n=0.5$ mSv and $H_n/H_p=2.6/1$, while in the other fields the accuracy values are better than 18%. The total dose equivalent estimation is very good (accuracy is better than 12% in all cases) due to the opposite bias in the neutron and photon dose equivalent estimations. The opposite bias result is expected due to the use of a single TLD element to estimate both neutron and photon dose equivalents in our methodology.

ERROR ANALYSIS

The good dose equivalent measurement performance shown in Table 1 is an ideal case in which the neutron and photon sources are known (so peaks ratios and sensitivities are both known with small errors). In real fields, the photon and neutron spectra may be known only to a limited extent. In that case, although photon sensitivity has a small error due to the small energy-dependence of TLD-600 to photons, the photon peaks ratio may have a large error (peaks ratio varies from 0.01 to 0.02). In contrast to the case for photons, the neutron sensitivity may have a large error if the neutron energy is not well known, while the neutron peaks ratio is still a constant of 0.15. In either case, the uncertainty in photon or neutron energy can result in error to the neutron and photon dose equivalent estimations.

An error analysis can be performed by calculating the variations of the neutron and photon dose equivalent estimations as a function of the variation of the neutron or photon peaks ratio. Figure 5 shows the fractional changes in the neutron and photon dose equivalent estimations, if the photon peaks ratio is changed from 0.01 to 0.02. For this increase in the photon peaks ratio, the fractional change in the photon dose equivalent estimation is increased, but the fractional change in the neutron dose equivalent estimation is decreased. The fraction increase in the photon dose equivalent estimation is 9-11% in any field, regardless of neutron source type and the H_n/H_p ratio. The fractional decrease in the neutron dose equivalent estimation, however, shows strong dependence on both the neutron source type and the H_n/H_p ratio. Extreme results in the ^{137}Cs fields mixed with $^{252}\text{Cf}(\text{D}_2\text{O})$ or $^{238}\text{PuBe}$ are shown in Figure 5. The fractional decrease is higher when H_n/H_p is lower; it is <10% in the mixed fields with $^{252}\text{Cf}(\text{D}_2\text{O})$ in any H_n/H_p ratio; the decrease can be as high as 90% in a $^{238}\text{PuBe}$ mixed field with a H_n/H_p of 0.1. Fortunately, the fractional change of total dose equivalent, which can also be estimated from Figure 5, is less than 8% in any mixed field with $^{252}\text{Cf}(\text{D}_2\text{O})$ and less than 1% in any mixed field with $^{238}\text{PuBe}$.

Figure 6 shows the fractional changes in the neutron and photon dose equivalent estimations, if the neutron peaks ratio is changed from 0.15 to 0.14 (i.e., changed by 1%). The situation in Figure 6 is reversed from that in Figure 5. The fractional increase in the neutron dose equivalent estimation is 9-10% in any mixed field, regardless of neutron source type and the H_n/H_p ratio. The fractional decrease in the photon dose equivalent estimation has strong dependence on both the neutron source and the H_n/H_p ratio. The fractional decrease is higher when H_n/H_p is higher; it is as high as 95% in a $^{238}\text{PuBe}$ mixed field with a H_n/H_p of 10. The fractional decrease in the photon dose equivalent estimation in a $^{252}\text{Cf}(\text{D}_2\text{O})$ mixed

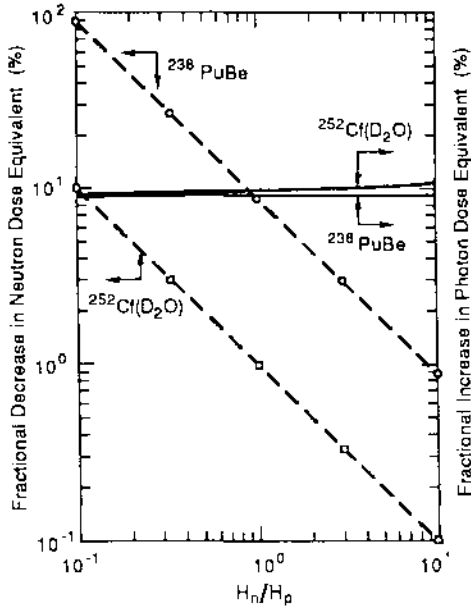

Figure 5. Fractional changes in the neutron and photon dose equivalent estimations in mixed neutron-photon fields, if the peaks ratio for photons is changed from 0.01 to 0.02. Extreme results in the mixed fields with two different neutron sources are shown.

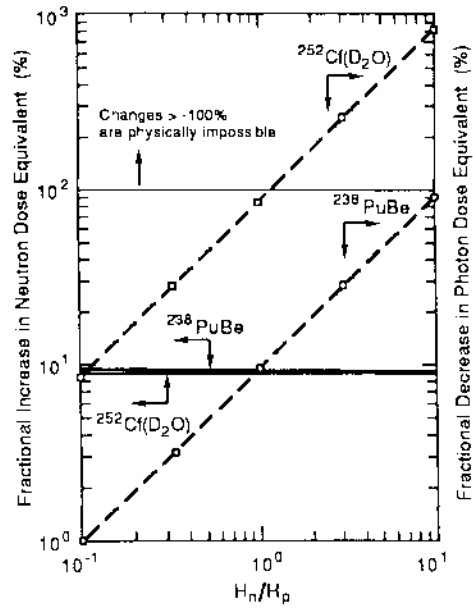

Figure 6. Fractional changes in the neutron and photon dose equivalent estimations in mixed neutron-photon fields, if the peaks ratio for neutrons is changed from 0.15 to 0.14. Extreme results in the mixed fields with two different neutron sources are shown.

field could be larger than -100%, but this is only a calculated value and is physically impossible. The fractional change in the total dose equivalent estimation in a mixed field with $^{238}\text{PuBe}$ is <1% in all cases. The fractional decrease in the total dose equivalent estimation in a $^{252}\text{Cf}(\text{D}_2\text{O})$ mixed field with a $H_n/H_p = 1$ could be as high as 50%.

DISCUSSION

The upper linear response level of the peaks 6-7 in our study is ~3 mSv for neutrons and ~20 mSv for gammas. Using a three-month dosimeter exchange period, the maximum neutron and gamma dose equivalent limits per year with no supralinear peaks 6-7 response are 12 mSv and 80 mSv, respectively. Therefore, the high temperature peak dosimetry is suitable for most protection dosimetry situations, but not for accident dosimetry.

Low sensitivity of peaks 6-7 to photons (only 0.012 mGy mSv⁻¹) might lead to an impression of insufficient photon sensitivity of this method for use in protection dosimetry. Key points in the high temperature peak methodology are: using the high peaks 3-7 sensitivities of the TLD-600 for photons and neutrons to detect both photons and neutrons, and using the very different peaks 6-7 sensitivities for photons and neutrons to differentiate the photons and neutrons. Therefore, the photon and neutron peaks ratios should be accurately determined, so that the photon and neutron signals can be well separated. The good test results in Table 1 also prove that the method is appropriate for protection dosimetry.

Other concerns are the reproducibility of the peaks ratio during reuse and the variation of the peaks ratios within a group of TLDs. For example, the fading of peaks 2-3 would affect the peaks ratio value if the fading effect is not properly accounted for. A more stable peaks ratio value can be obtained, at the expense of total sensitivity, by using a narrower region of interest (e.g., covering only peaks 4-5). Our experience shows that the current settings of the two regions of interest and the heating profile can achieve a satisfactory result for at least a one-month fading period. The peaks ratio may not be chip-dependent, but it can be batch-dependent. A simpler solution is to use the mean peaks ratio for a batch, if the variation of the peaks ratios within a batch is acceptable. A more complicated solution is to generate individual neutron and photon peaks ratio values for every TLD-600 element. This is a tedious but not difficult procedure, and the mass data manipulation associated with it is easy in a computer-aided TLD system.

CONCLUSION

The high temperature peaks characteristics of the reader-annealed TLD-600 have been studied. The high temperature peaks have linear responses for neutrons, but supralinearity starts at about 20 mSv for gammas. The peaks ratio is 0.15 for neutrons of any energy, and is energy-dependent for photons (0.01 for ^{137}Cs , and up to 0.02 for x-rays below 100 keV). A mixed field neutron-photon protection dosimetry using a single Cd-covered TLD-600 element was developed and evaluated in different mixed field conditions. The results and an error analysis show that such mixed-field dosimetry would work well if both the neutron and photon sources are known. Otherwise, the neutron and photon dose equivalent estimations may have large errors, depending on the peaks ratio error, the neutron source type, and the neutron/photon dose equivalent ratio in the mixed field.

ACKNOWLEDGEMENTS

This work was supported in part by US Department of Energy contracts DE-AC03-76SF00515 and DE-AC05-84OR21400.

REFERENCES

1. Harshaw/Filtrol, 1988. Computerized Glow Curve Deconvolution User's Manual, Harshaw/Filtrol Partnership, Solon, OH, US
2. Liu, J. C., Sims, C. S., and Rhea, T. A., 1989. Optimization of the Readout Procedures for the Harshaw 8800 Automatic TL Dosimetry System. *Radiat. Prot. Manag.*, 6, 55-70.
3. Liu, J. C., Sims, C. S., and Poston, J. W., 1989. The Development, Characterization, and Performance Evaluation of a New Combination Type Personnel Neutron Dosimeter. Oak Ridge National Laboratory, ORNL-6593.
4. U.S. Department of Energy, 1986. Department of Energy Standard for the Performance Testing of Personnel Dosimetry Systems, US Government Printing Office, DOE/EH-0027.
5. Busuoli, G., Cavallini, A., Fasso, A., and Rimondi, O., 1970. Mixed Radiation Dosimetry with LiF (TLD-100). *Phys. Med. Biol.*, 15, 4, 673-681.
6. Shachar, B. B., and Horowitz, Y. S., 1988. Dosimetric Characterization of the High Temperature Peaks of LiF:Mg, Ti and CaF₂:Tm Using Computerized Glow Curve Deconvolution. *Radiat. Prot. Dosim.*, 22, 2, 87-96.
7. Budd, T., Marshall, M., Feaple, L. E. J., and Douglas, J. A., 1979. The Low- and High-Temperature Response of Lithium Fluoride Dosimeters to X-rays. *Phys. Med. Biol.*, 24, 1, 71-80.
8. Dolles, A. E. and Geiger, E. L. Separate Identification of Neutron and Gamma Exposures of Lithium Fluoride (TLD-100) Used for Personnel Dosimetry, Eberline Instrument Corporation Internal Report.

RADIATION MONITORING SYSTEM
APPLICABLE TO A NUCLEAR FUSION EXPERIMENTAL SITE

H. Obayashi, J. Kodaira, Y. Sakuma,
M. Miyajima¹ and T. Yamamoto²

National Institute for Fusion Science, Chikusaku, Nagoya,
464-01 Japan

¹National Laboratory for High Energy Physics, Oho, Tsukuba,
305 Japan

²Institute of Scientific and Industrial Research,
Osaka University, Ibaraki, 567 Japan

ABSTRACT

An area monitoring network system, RMSAFE, has been developed at NIFS for the application to the LHD fusion plasma experiment. Radiation emissions of intermittent burst-like pulses will be detected and measured in a passive monitoring way. Preliminary operations have been made.

INTRODUCTION

In order to monitor the radiations (X-rays and neutrons) emitted from high temperature plasma experiments for fusion studies, a system network of detectors named the Radiation Monitoring System Applicable to Fusion Experiments (RMSAFE) has been considered and developed. This is an area monitoring system of passive nature and is going to be applied to the experimental site of the National Institute for Fusion Science in Toki, Japan, where a new toroidal plasma machine called Large Helical Device (LHD) will come to operation within several years.¹ Although no tritium will be introduced into the machine, a certain amount of neutron yields together with X-rays will be given in deuterium plasma operations. These radiations should be monitored and controlled in a reliable way.

In the course of preparing the RMSAFE system it is needed to carry out considerable R & D work and for that purpose a prototype system (proto-RMSAFE) has been constructed at the present campus of NIFS in Higashiyama (30km from Toki), where plasma experiments with smaller sized devices, CHS and JIPP T-II U, are going on.²

SCOPE AND CONCEPT OF RMSAFE

The detailed operational conditions in the coming LHD experiments are still under discussion, but in typical modes of operation plasma discharges will take place with 0.5 ~ 10 sec in duration and 5 ~ 10 min of repetition cycle. The radiations are to associate with plasma shots and therefore they may appear as intermittent burst-like pulses. Some 1000 full shots are expected a year.

RMSAFE SYSTEM OUTLINE

In Fig. 1 is shown a schematic framework of RMSAFE now under construction. Since the main experimental building for LHD will not come out until a few years, here we are considering the sensors only in categories C and D, which are consisting of pressurized Ar-ion chambers and He-3 proportional counters, to detect environmental levels of gamma rays and neutrons, respectively. For the time being, seven monitoring points (two in the site and five on the borders) have been selected. Signals from these detectors are transmitted through optical cable lines to three 4-channel scalers. These scalers are interfaced with a GPIB box, and are connected with an engineering workstation playing as the central data processor of the system. The raw signals from each sensor are digitalized and counted by the scaler according to the mode selected. The observed data are analysed and recorded in the central data processor. The system is in connection with an Ethernet line to other experimental systems, for instance, alarm or interlock systems of the machine operation.

There are three modes of data counting function, Background (BG) Mode, Burst (BS) Mode and Time-profile (TP) Mode. In BG Mode, the sensor signals are sampled in a time width T are consecutively recorded, irrespectively of occurrence of burst-like events. $T = 30$ s is typically taken. A burst-like event is identified, if a rapid increase beyond a preset value is noticed in signals from a sensor during a short time span, say 50 ms, by means of an installed burst-detecting circuit. In case the system is in BS Mode or TP Mode, the counting status of all the sensors are immediately switched into the time profile counting one, where fine structures of signal evolution are counted for a period of 105τ , where τ denotes a preset time of sampling resolution and usually $10 \sim 200$ ms. In BS Mode the total signal intensities during the burst event together with the onset time are dealt with, while in TP Mode the detailed time profile records will be given as output. Unless a burst-like pulse event is encountered, the system remains in the background counting status, just the same as in BG Mode, so that the background components during the burst are extrapolated from the preceeding periods and subtracted to give the net burst contributions in BS and TP Modes.

DATA EXAMPLES

Figure 2 shows an example of Background Mode data obtained from an ionization chamber placed at a site border region in Toki. The output current from the chamber is given as counts/30sec, and is converted to the gamma dose rate in nSv/h. The observed data will give a mean level of (57.42 ± 2.45) nSv/h, which value is quite consistent with other environmental measurements made in this place, say, TLD giving 60.7 nSv/h.

In the Toki site it is strongly required that the radiational impacts on the environments should be kept as small as possible, and as a guideline it is given for an annual amount of dose contributions of experimental origin not to exceed $50\mu\text{ Sv}$ on the site boundaries.³

It is rather severe task to hold this amount reliably monitored, if we consider a natural background level of environmental radiations, typically $0.5 \sim 1\text{ mSv/y}$ in this area, with usual fluctuation of $\sim 10\%$, so that the net integrated dose limit $50\mu\text{ Sv/y}$ would be below the natural fluctuation levels. But it might be possible to catch them up, if the pulsed nature of experiments is taken into account. Suppose that 1000 full shots of radiation emitting plasma experiments are given in a year, then a single shot could share 50 nSv/shot in average, or a level of dose rate 5 nSv/s for 10-s duration, which value is well higher than the background rate of $15 \sim 30\text{ pSv/s}$.

The monitoring system is required to identify such pulses apart from the background level and to accumulate their dose contributions. So, this implies the dosimetry work to respond nSv/s range with 0.1 s time resolution. It is, however, not very easy to detect such faint pulses by use of a single detector. In order not to miss the pulse events as well as to find out the spatial distribution of emitted radiations, a number of sensors should be distributed over the site area, the Toki site being 47 ha in area, to form a network system.

The concept of RMSAFE has been developed to meet these requirements. Its characteristics are summarised as follows:

- (a) It is a sensor network system covering the whole area of the site to make the continuous monitoring of radiation fields (usually gamma rays and neutrons).
- (b) All the signals from the sensors are directly connected to a central monitoring data processor to find out the real time situation over the whole site area throughout the year round.
- (c) A burst-like pulse event of radiations can be detected and identified by sensor signals themselves, the system being operative in a passive way.
- (d) Once a burst is noticed by any one of the sensors, the whole system is turned into burst analysing status to make detailed observations and recordings.
- (e) In the period of no bursts, the background radiation levels are monitored continuously.
- (f) Sensors may be categorized in accordance with the radiation species and levels locally expected. For the time being, following 4 zones of monitoring position are considered:
 - A. Inside the shielded experimental hall
 - B. Indoor monitoring points out of the shielded area
 - C. Outdoor monitoring points in the site
 - D. On the site boundaries
- (g) The system would easily be extensible, in case of additional sensors and points needed.

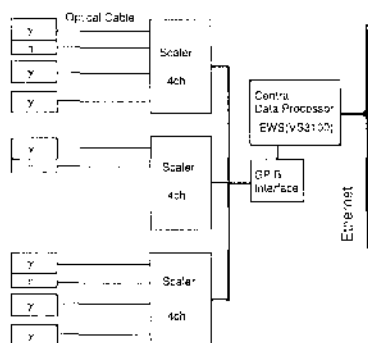

Fig.1 RMSAFE system.

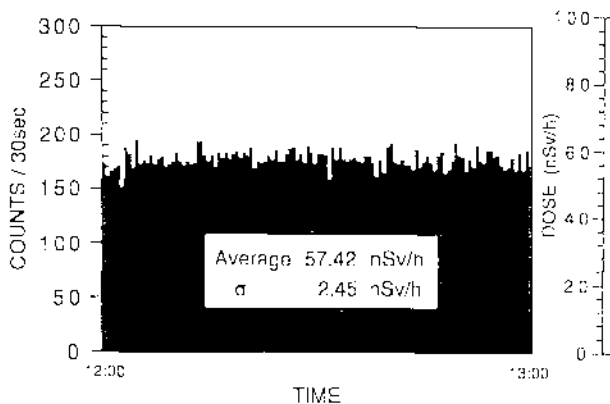

Fig.2 Background data for gamma rays in Toki.

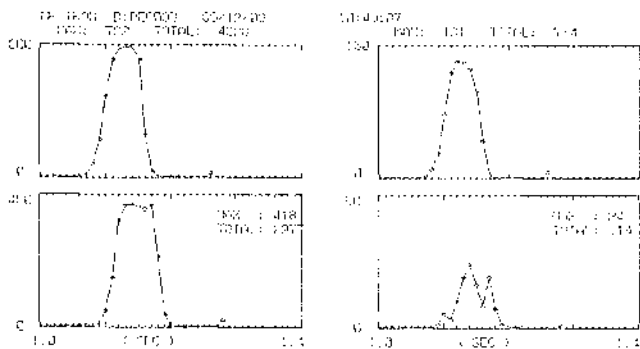

Fig.3 Time-profile data for neutrons from JIPP T-II U.

In Fig.3, another example taken with proto-RMSAFE is given. Here neutron observations with four detectors of different type were carried out around JIPP T-II U tokamak. The system is operated in Time-Profile Mode, and the data outputs are well representing the characteristics of neutron emissions associated with the plasma discharge.

CONCLUDING REMARKS

The idea of RMSAFE has been found useful in monitoring operations, though it may be necessary to make further R and D investigations for higher reliability. In parallel to the actual system construction of RMSAFE in Toki, studies with proto-RMSAFE will be made on the practical issues around the existing plasma experiments.

REFERENCES

1. A. Iiyoshi, et al., Fusion Tech. 17 (1991) 169.
2. J.Kodaira, et al., Proc. 5th Workshop on Radiation Detectors and Their Uses, KEK Report 90-11, (1990) 161.
3. H. Obayashi, et al., Nucl. Eng. Des./Fusion 4(1987) 425.

**HIGH LEVEL DOSIMETRY AT
THE STANFORD LINEAR ACCELERATOR CENTER***

N. E. Ipe and J. C. Liu

Stanford Linear Accelerator Center,
Stanford University, Stanford, CA 94309, USA

The Stanford Linear Accelerator Center (SLAC) operates a high energy electron accelerator (capable of energies up to 50 GeV). During operation the instantaneous dose rates in the vicinity of the beam pipe due to beam losses can be extremely high. This results in large accumulated doses to beamline components and nearby devices. Since these large doses can cause damage to some of these components and devices, there is always a need for high level dosimetry at SLAC.

Several types of high level dosimeters are used in order to cover a wide range of doses extending from about 10 Gy to 1 MGy. These are optichromic, radiachromic, red perspex, cinemoid (bright rose film #48), and Lexan dosimeters. The response curve for each of these dosimeters is presented. Some practical difficulties associated with their use in the field will also be reported.

INTRODUCTION

The Stanford Linear Accelerator Center (SLAC) operates a high energy electron accelerator (capable of energies up to 50 GeV). During operation the instantaneous dose rates in the vicinity of the beam pipe, due to beam losses, can be extremely high. This results in large accumulated doses (from electrons, photons and neutrons) to beamline components and nearby devices. In addition synchrotron radiation from storage rings can deliver very high doses. Since these large doses can cause damage to some of these components and devices, there is a need for high level dosimetry at SLAC.

Radiation damage depends on both integrated dose as well as the dose rate, in addition to environmental factors such as temperature and humidity. Equal doses from different types of radiation do not necessarily produce equal damage⁽¹⁾. For instance, for electronics and semiconductor devices, the displacement of atoms by neutrons is more damaging than ionization by electrons or photons. Whereas for organic insulating materials, the damage depends mainly on the dose and is independent of the type of radiation.

Exposure of plastics and films to electrons and photons results in a number of temporary and permanent changes, such as in appearance, chemical and physical states and in mechanical properties. Some substances undergo a change in color upon irradiation, which affects their light transmission. The change in transmission (T) or optical density (OD = log 1/T) of a material at a suitable wavelength can be used as an index for dose. This is essentially the principle behind the high level dosimeters used at SLAC.

Several types of high level dosimeters are used to cover a wide range of doses extending from about 10 Gy to 1 MGy. These

* Work supported by Department of Energy contract DE-AC03-76SF00515.

are optichromic, red perspex, radiachromic, cinemoid and lexan dosimeters.

EXPERIMENTAL METHODS

The opti-chromic (FWT 70-40M, Batch C-1 and FWT 70-83M, Batch C-3) and radiachromic dosimeters were obtained from Far West Technology, Inc.^a

The opti-chromic dosimeters were exposed in holders which provided protection from stray light. The radiachromic dosimeters were sealed in aluminum laminate pouches for protection from humidity changes and stray light during exposure. The radiachromic dosimeters were about 0.05 mm thick. The red perspex^b, cinemoid^c (bright rose film #48), and lexan^b dosimeters were about 0.32, 0.023, and 0.32 cm. thick.

The perspex and Lexan dosimeters were wrapped in black opaque plastic and together with cinemoid were held in a plastic badge whose front surface was about 0.5 mm thick.

Gamma Irradiation

Dosimeters were exposed to gamma radiation using the ⁶⁰Co sources (Hotrod Model U, Nuclear Systems) at U.C. Santa Cruz, California and Lawrence Berkeley Laboratory, California. Build-up materials consisting of plexiglass or polycarbonate were used to achieve electronic equilibrium. The dose rates range from 74-81 MGy/s and 0.6 mGy/s to 0.4 Gy/s (exposure rates were converted to dose rates using a conversion factor of 0.95). The opti-chromic, red perspex, cinemoid and lexan dosimeters were exposed to doses ranging between about 0.15 kGy and 90 kGy. All irradiations were performed at room temperature.

Electron Irradiation

The electron irradiations were performed using an electron beam accelerator (energy = 4.5 MeV).^c

The surface doses were monitored using radiachromic films which were calibrated by the National Institute of Standards, Washington D.C. The dose rates ranged between 6.7 and 8 kGy/s. All irradiations were performed at room temperature. All dosimeter types were exposed to electrons.

Dosimeter Readout

The Macbeth quantalog densitometer (TD-102) was used to determine the optical density for red perspex (using gold/visual and red filters) cinemoid (green filter) radiachromic (green filter) and lexan (gold and blue filters).

The Far West Technology Opti-chromic (FWT-98) and Radiachromic (FWT-91R) readers were used to read the opti-chromic and radiachromic dosimeters, respectively. Wavelengths of 600, 656 and 680 nm were used for the opti-chromic and 510 nm for the radiachromic dosimeters (the 610 nm wavelength was not useful for this study).

^a Far West Technology Inc., 330-D S. Kellogg, Goleta, CA 93017, USA.

^b Port Plastics, Inc., 1047 N. Fair Oaks Blvd., Sunnyvale, CA 94089, USA.

^c Rank Strand Ltd., PO Box 51, Great West Rd., Brentwood, Middlesex TW89HR, UK.

^d E-Beam Services Inc., 32 Melrick Rd., Cranbury, NJ 08512, USA.

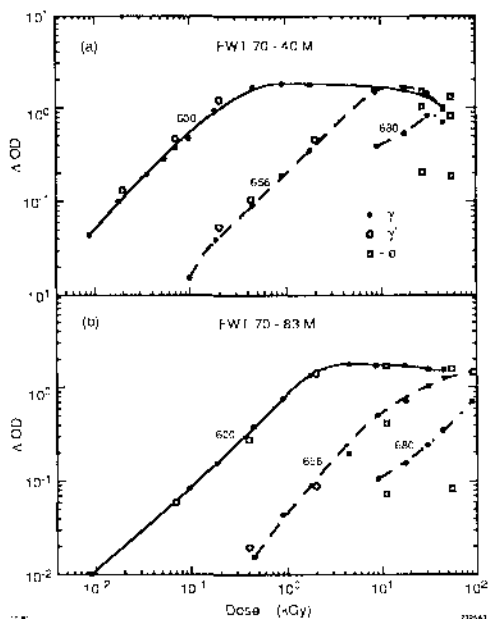

Fig. 1: Response of Opti-chromic Dosimeters.

Two dosimeters were used per irradiation condition and at least four readings were taken per dosimeter (except radiachromic, for which only one reading was taken). Two controls were used for each dosimeter. The difference in the average optical density between the irradiated dosimeter and the control (ΔOD) was then determined.

RESULTS

Opti-chromic and radiachromic dosimeters

The response of the opti-chromic dosimeters for gammas (γ) and electrons (e^-) is shown in Figure 1. The data provided by the manufacturer for ^{60}Co irradiation is also shown (γ'). The curves have been drawn only to aid the eye.

For both FWT 70 40M and 70 83M, the manufacturer data agrees reasonably well with the data obtained in this study at 600 and 656 nm. At these two wavelengths, the gamma and electron responses are fairly equivalent. However, at 680 nm, the electron response is much lower than the gamma response. At doses of about 75 KGy, the dosimeters started disintegrating.

Opti-chromic dosimeters consist of the liquid form of a radiachromic material in an optical waveguide⁽²⁾. Radiachromic materials are so-called because they exhibit a change in color upon irradiation. The optical properties of the waveguide change with the formation of color centers and hence these dosimeters are called opti-chromic.

The response of radiachromic dosimeters is shown in Figure 2. The response to electrons obtained with the densitometer (green) is higher than the response obtained with the

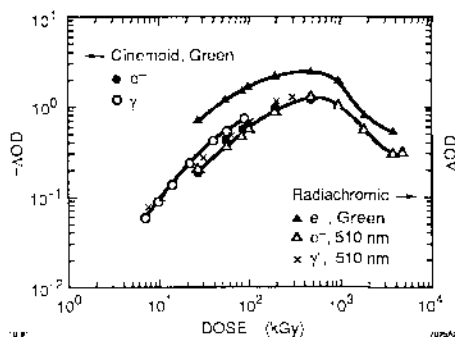

Fig. 2: Response of Radiachromic and Cinemoid Dosimeters.

reader, though the shape of the curves are very similar. The data provided by the manufacturer for ^{60}Co gamma irradiation (γ') is also shown. The response for gammas and electrons appears to be fairly equivalent. The response decreases for doses greater than 500 kGy. The radiachromic dosimeters change from a clear colorless film to a deep blue with increasing radiation doses. These dosimeters are dose-rate independent to 10^{13} Gy/s, have an equivalent response to x-rays, gammas and electrons, small temperature dependence and a long shelf life⁽³⁾.

Red Perspex

The response of red perspex is shown in Figure 3. The response to electrons (e^-) and gammas (γ) is almost the same. The response obtained with the gold filter is similar to that obtained with the red filter. The response begins to decrease for doses greater than 50 kGy. Red perspex changes from a deep red to a dark red and then to brown with increasing doses. The material begins to become opaque as doses approach 1 MGy, and disintegrates thereafter.

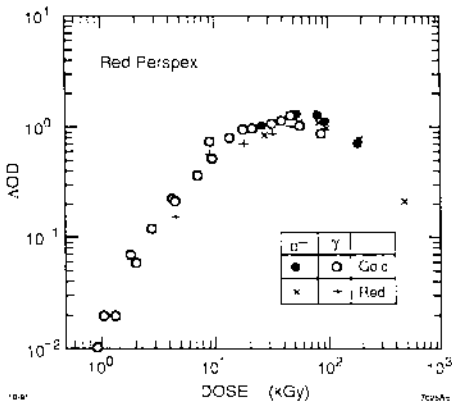

Fig. 3: Response of Red Perspex.

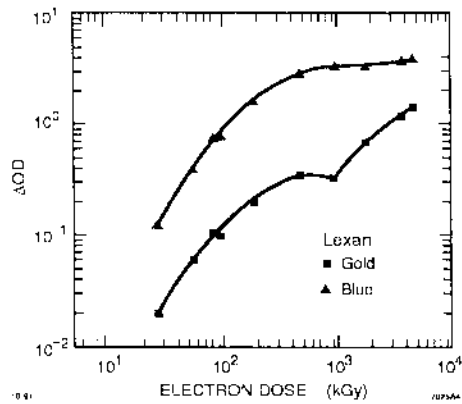

Fig. 4: Response of Lexan.

Red perspex (polymethyl methacrylate) is sensitive to temperature and humidity effects and suffers from fading⁽⁴⁾. Studies in progress indicate a 20% decrease in response for a storage period of about two weeks for doses greater than 50 kGy⁽⁵⁾. The response of red perspex is dose rate dependent for doses greater than 10^5 Gy/sec⁽⁴⁾.

Cinemoid

The response ($-\Delta\text{OD}$) of cinemoid (using green filter) is shown in Figure 2. The response for gammas is slightly higher than the response for electrons. The optical density of cinemoid decreases with increasing doses. Cinemoid changes from a bright rose to paler shades of salmon with increasing doses. The response decreases (optical density increases) for doses greater than 500 kGy. At doses approaching 500 kGy, the cinemoid becomes brownish yellow and very brittle. At higher doses, the cinemoid disintegrates. Cinemoid stored at room temperature for two weeks after irradiation did not show any significant fading⁽⁵⁾. The response of cinemoid (dyed cellulose nitrate) is independent of

dose rate for dose rates up to 10^{12} Gy/s⁽⁶⁾. Temperature rises of more than 80° destroys the dosimeter.

Lexan

The response of Lexan using blue and gold filters is shown in Figure 4. A higher response is obtained with the blue filter, for which the response levels off at doses greater than 1 MGy. The response with the blue filter decreases at doses greater than 600 kGy and then sharply increases with increasing doses. Lexan changes from a clear plastic to yellow and then dark brown with increasing radiation doses. Lexan also suffers from fading⁽⁵⁾. For doses between 25 and 100 kGy, there was a 40% reduction in response after storage for about two weeks.

CONCLUSIONS

Table 1 lists the useful ranges of the various high level dosimeters used at SLAC. Since most of these dosimeters have responses that decrease at very high doses, the use of a single dosimeter type can lead to erroneous results at high doses. Hence, a combination of dosimeter types should be used to determine doses. There are some practical difficulties associated with the use of these dosimeters in the field. Fading, sensitivity to temperature, light, humidity and dose-rate dependence can sometimes lead to large uncertainties. A typical accelerator operating run may last for months and the exact time at which the beam losses take place is not known. Hence it is difficult to correct for fading during the run. In addition, mixed fields of photons and neutrons exist in the vicinity of the accelerator, and the responses of these dosimeters to neutrons is not known. All these factors can lead to uncertainties that range from factors of about 2 to 5 in dose determination.

Dosimeter	Wavelength (nm) or Filter	Range (kGy)
Opti-chromic FWT 70-40 M	600 656 680*	0.01 - 1 0.1 - 10 30 (γ)
Opti-chromic FWT 70-83 M	600 656 680*	0.07 - 4 0.4 - 100 30 (γ)
Red Perspex	Gold Red	1 - 50 1 - 50
Radiachromic	600 510 Green	1 - 40 5 - 500 - 500
Cinemoid	Green	7 - 500
Lexan	Gold Blue	25 - 600 25 - 1000

*Lower limit not established

1397 (25/86)

Acknowledgements

The authors are grateful to Gary Schleimer of Lawrence Berkeley Laboratory and Kathy O'Shaughnessy of UC Santa Cruz for their help with the ⁶⁰Co irradiations. Acknowledgements are due to Sara Warren for reading out some of the dosimeters and the SLAC Publications Department for help with the preparation of this manuscript.

Table 1: Range of Dosimeters.

REFERENCES

1. Schonbacher, H., Radiation Damage Studies for Detector Materials, CERN-TIS/CFM/89-16/CF, CERN, Geneva (1989).
2. Reader's Manual FWT-98 Opti-chromic Reader for Radiation Processing, Far West Technology, Goleta, CA, USA.
3. Humphreys, K. C. and Kantz, A. D., Radiachromic: A Radiation Monitoring System, Radiat. Physics Chem. 9, 737-747 (1977).
4. Whitaker, B., Red Perspex Dosimetry in *Manual on Radiation Dosimetry*, edited by N. W. Holm and Roger Berry (New York: Marcel Dekker, Inc.) (1970).
5. Ipe, N. E. and Liu, J. C., High Level Dosimetry at the Stanford Accelerator Center, SLAC-PUB-5686 (extended version), Stanford Linear Accelerator Center, Stanford, CA, USA (1991).
6. Goldstein, N., Cinemoid Color Films in *Manual on Radiation Dosimetry*, edited by N. W. Holm and Roger Berry (New York: Marcel Dekker, Inc.) (1970).

SILENE : SOURCE DE RAYONNEMENTS DE REFERENCE

R. MEDIONI* - F. BARBRY**

CEA/Institut de Protection et de Sûreté Nucléaire

*Département de Protection de la santé
de l'Homme et de Dosimétrie

**Département de Recherches en Sécurité

SILENE, A SOURCE OF REFERENCE RADIATION FIELDS

The Silène reactor is an experimental facility designed to investigate the sequence of events and the consequences of criticality accident from both physical and radiological standpoints.

The small core volume, the use of shields of various sizes and materials, the properties of the leakage radiation and particularly the neutron/gamma dose ratios, the wide range of dose rate values, and the variety of operating modes make the unit a powerful research tool to meet the requirements of physicists, neutronics or dosimetry specialists and biologists.

I - INTRODUCTION -

Dans le but d'étudier le déroulement et les conséquences des accidents de criticité tant du point de vue physique que radiologique, l'Institut de Protection et de Sûreté Nucléaire du CEA a conçu et réalisé un dispositif expérimental sur le site de Valduc [1].

La source SILENE est un réacteur à combustible liquide qui présente à la fois une grande souplesse d'utilisation et une sûreté intrinsèque de haut niveau.

Le faible volume du coeur, l'utilisation d'écrans de nature et de dimensions diverses, l'intensité des rayonnements gamma et neutron émis ainsi que les divers modes de fonctionnement possibles en font un outil très puissant, susceptible de répondre à l'attente de nombreux expérimentateurs qu'ils soient physiciens, neutroniciens, dosimétristes ou biologistes.

II - LE REACTEUR SILENE - SES POSSIBILITES -

1 - Le coeur : c'est une cuve annulaire de 36 cm de diamètre traversée en son axe par un canal de 7 cm de diamètre. L'ensemble est placé au centre d'une cellule en béton de grandes dimensions (19 x 12 x 10 m).

Le réacteur utilise comme combustible une solution fissile de nitrate d'uranyle. Il en résulte deux avantages :

- une sûreté intrinsèque grâce à deux mécanismes de contre-réaction (échauffement de la solution et effet de vide dû à l'apparition de gaz de radiolyse).

- une grande souplesse d'exploitation (adaptation des caractéristiques du coeur à toute configuration expérimentale).

Le fonctionnement est obtenu en introduisant la solution fissile dans la cuve du coeur. L'excursion de puissance est réalisée par extraction d'une barre de réactivité se déplaçant dans le canal central.

En fin d'expérience la solution fissile irradiée est vidangée dans une cuve spéciale placée dans un local blindé ce qui autorise un accès rapide dans la cellule.

2 - Les modes de fonctionnement : Silène est conçu pour fonctionner selon trois modes :

- . en "salve" : l'excursion de puissance est brève (quelques millisecondes) mais très énergétique (jusqu'à 1000 mégawatts),
- . en "libre évolution" : on laisse évoluer librement l'excursion de puissance pour simuler un accident de criticité,
- . en "palier" : le réacteur fonctionne à une puissance stable prédéterminée (niveau compris entre 10^{-2} watt et 10^4 watts) pendant le temps désiré. Dans ce mode, le débit de dose due aux neutrons peut varier, suivant la puissance choisie de 5.10^{-9} à 5.10^{-3} Gy.s⁻¹ (à une distance de 4 m du réacteur nu).

3 - Les écrans :

Des écrans cylindriques peuvent être disposés autour de la source de manière à modifier les caractéristiques des rayonnements de fuite, par exemple dégrader le spectre des neutrons et modifier le rapport de la dose γ à la dose neutron. A cet effet deux écrans, l'un en plomb, l'autre en polyéthylène ont été réalisés et étudiés. Un écran d'acier sera qualifié prochainement.

Le vaste espace environnant le coeur du réacteur (230 m² au sol) permet l'irradiation de fantômes ou d'objets volumineux sur des arcs correspondant à des isodoses. Des écrans supplémentaires (murs de béton) peuvent être disposés dans la salle d'irradiation pour simuler des situations particulières.

III - CARACTERISTIQUES DES RAYONNEMENTS EMIS [2] -

Grâce aux différents modes de fonctionnement possibles, Silène offre une large gamme de débits de dose (10^{-8} Gy.s⁻¹ à 300 Gy.s⁻¹ pour la dose neutron à 4 mètres du réacteur nu). Cette large dynamique permet l'utilisation de détecteurs ou d'appareils de mesure de sensibilités très différentes.

La caractérisation du champ de rayonnement a été effectuée à l'aide de différentes techniques :

- . pour le spectre des neutrons : détecteurs à activation, chambres à fission, spectrométrie par protons de recul,
- . pour les doses neutrons : chambres d'ionisation (équivalent tissu et aluminium) et diodes avec comparaison des valeurs déduites de la spectrométrie,
- . pour les doses gamma : thermoluminescence, compteur Geiger Muller compensé en énergie.

Le tableau 1 indique les principales caractéristiques du champ mixte émis à 4 m de l'axe du réacteur nu ou muni d'écran pour une puissance de 4.10^{17} fissions développées dans le réacteur (énergie maximale pour une expérience).

Ecran	Dose neutron (Gy)	Dose gamma (Gy)	Dose gamma ----- Dose neutron
Sans	6,0	8,0	1,3
Plomb	5,2	1,1	0,2
Polyéthylène	~ 0,4	5,2	> 10

Tableau 1 : Caractéristiques du champ de rayonnement à 4 m du réacteur pour 4.10^{17} fissions.

Le tableau 2 donne la distribution relative en fluence et en kerma selon cinq bandes d'énergie de neutrons. On constate l'effet de déplacement du spectre dû aux écrans (plomb ou polyéthylène) par rapport à la configuration source nue.

Bande d'énergie	Source nue		Ecran de plomb		Ecran de polyéthylène	
	Fluence	Kerma	Fluence	Kerma	Fluence	Kerma
$E_n < 0,5 \text{ eV}$	20,1	0,3	18,0	0,3	23,3	0,3
$0,5 \text{ eV} < E_n < 50 \text{ keV}$	35,4	1,1	33,4	1,2	33,4	1,0
$50 \text{ keV} < E_n < 1 \text{ MeV}$	19,8	24,6	29,4	40,2	14,3	15,4
$1 \text{ MeV} < E_n < 5 \text{ MeV}$	23,0	66,7	18,6	55,4	25,0	67,1
$5 \text{ MeV} < E_n < 15,5 \text{ MeV}$	1,6	7,3	0,6	2,9	4,0	16,2

Tableau 2 : Distribution relative de la fluence et du kerma exprimée en pour cent.

IV - EXEMPLES D'APPLICATIONS -

Les caractéristiques de la source (forme des spectres, rapport γ/n) et les grandes dimensions de l'espace libre environnant le coeur permettent des applications extrêmement nombreuses dans les programmes liés à la protection de l'homme. On peut citer :

1 - Dosimétrie :

- réalisation d'exercices pour l'entraînement des équipes chargées de la dosimétrie d'accident de criticité,
- étude et développement de nouveaux moyens de mesure,
- étalonnage d'instruments de radioprotection.

2 - Intervention :

- étude de la stratégie à appliquer en matière d'intervention après un accident de criticité,
- réponse et qualification de détecteurs d'alarme de criticité.

3 - Activation du sodium :

- étude de l'activation du sodium du sang et détermination de coefficients permettant l'évaluation des doses reçues par des individus en cas d'accident (influence de la forme du spectre et de l'orientation).

4 - Radiobiologie :

- étude de l'efficacité biologique des neutrons sur différents systèmes, induction de cancer, anomalies chromosomiques etc...,
- irradiation d'animaux de grande taille.

V - CONCLUSION -

Les possibilités d'irradiation simultanée de nombreux objets sur une même isodose, les spectres variés disponibles, la souplesse de l'installation permettent de proposer Silène comme source de référence au niveau international.

Actuellement, dans le cadre d'un groupe de travail de la Commission des Communautés Européennes (Eurados W.G 9) la source Silène a été retenue pour l'organisation d'une intercomparaison internationale des systèmes de dosimétrie utilisés en cas d'accident de criticité [3]. Cette intercomparaison est également cautionnée par l'AIEA et se déroulera au Centre d'Etudes de Valduc en 1993.

VI - BIBLIOGRAPHIE -

- [1] Commissariat à l'Energie Atomique.
"Silène, source de rayonnements de référence".
Plaquette d'information réalisée au sein de l'IPSN, 1987.
- [2] F. Barbry and R. Médioni ; Silène, a source of reference radiation fields. 7th Symposium on neutron dosimetry, 14-18 October 1991, Berlin.
- [3] R. Médioni, M. Buxerolle, H.J. Delafield and C.A. Perks ; Reference measurements of the leakage radiation field from the Silène reactor (lead shield) for an international intercomparison of criticality accident dosimetry systems. 7th Symposium on neutron dosimetry, 14-18 October 1991, Berlin.

SOME DOSIMETRIC CHARACTERISTICS OF THE RESIDUAL
DOSE AND THE PTTL FOR LiF:Ti,Mg

B. Ben-Shachar, U. German and E. Naim

Department of Health Physics and Safety
NRC-Negev, P.O.B. 9001, Beer-Sheva, 84190, Israel.

ABSTRACT

LiF:Ti,Mg TLD cards (G-1 and G-7) were irradiated in the range of 0.15 - 7.5 Gy and the residual dose and the PTTL were measured, in order to reassess the initial dose. We obtained a constant fraction of the initial dose (0.13% and 2.73% respectively) in the dose range 0.15 - 5.0 Gy for both the residual dose and the PTTL.

We evaluated the minimum exposure that can be reassessed, as well, when using both methods. We found that the minimum detectable exposure is ~13 mGy measured by the PTTL and ~380 mGy measured by the residual dose.

INTRODUCTION

The thermoluminescent dosimeter has become increasingly important in all aspects of personal and environmental monitoring. The main limiting factor that has prevented even a wider use is the loosing of the information accumulated in the crystal during the readout process.

LiF:Ti,Mg, proposed by Cameron (1), has been extensively used in dosimetry and it is a good compromise between the various desired characteristics. It is not as sensitive as certain other materials, but allows doses of 0.1 mGy to be measured with high performance equipment. The absence of thermal and optical fading (when different annealings are used) and almost tissue equivalence makes it the most useful TL material in radioprotection (2). There are two ways of reassessing high doses: by measuring the residual dose (second reading) or by the photo-transferred thermoluminescence (PTTL). The PTTL is the thermoluminescence after u.v. light exposure in a phosphor (3) which has been earlier exposed to ionizing radiation, then annealed and readout, leaving some TL as residual (RTL). The LiF:Ti,Mg has deep traps that can be significantly populated by high doses of ionizing radiation. Because normal readout procedures (heating to about 300°C) usually do not depopulate these traps, a second u.v. irradiation followed by the conventional readout can produce a response which is proportional to the original high dose. These "memory effects" in the TL materials can be employed for the re-estimation of doses and have been reported in several works (4,5,6).

The aim of the present work was to measure the residual dose and the PTTL for high doses (to 7.5 Gy) and to determine the accuracy and the minimum detectable level of the initial dose which can be determined by the two methods.

EXPERIMENTAL MEASUREMENTS

The measurements of the residual doses and the PTTL were performed with the standard LiF:Ti,Mg Harshaw manufactured G-1 or G-7 TLD cards. No annealing was performed. The cards were evaluated in an automatic Harshaw 2271 reader after being irradiated by a $^{90}\text{Sr}/^{90}\text{Y}$ source built in the system. The u.v. irradiation was performed by a 15 mw u.v. lamp (254 nm) at a distance of about 10 cm.

The TLD cards were irradiated to different doses between 0.15 and 7.5 Gy. The phosphors were evaluated immediately after the irradiation and a second reading was performed to measure the residual dose. After the second reading, the cards were irradiated by the u.v. lamp for 15 minutes and then read again (to measure the PTTL). The average results of the residual dose and the PTTL, obtained from the irradiation of 2 cards (four chips) for each dose, are presented in table 1.

Table 1: The average results of the residual doses and PTTL for exposures of 0.15 - 7.5 Gy.

Exposure (Gy)	Residual dose (mGy)	% of exposure	PTTL (mGy)	% of exposure
0.15	0.20±0.10	0.13	4.8± 0.5	3.20
0.30	0.35±0.06	0.12	7.5± 0.8	2.50
0.45	0.43±0.06	0.10	9.5± 1.0	2.11
0.60	0.75±0.07	0.13	12.1± 1.7	2.02
0.75	1.17±0.17	0.16	19.7± 1.7	2.63
1.00	1.24±0.27	0.12	31.6±10.3	3.16
1.85	2.38±0.56	0.13	55.3±12.2	2.99
3.00	3.67±0.85	0.12	77.9± 8.4	2.60
4.24	4.90±1.60	0.12	139.3± 8.5	3.29
5.66	10.16±2.18	0.18	156.2±27.0	2.76
6.60	14.77±0.66	0.22	256.1±61.8	3.91
7.50	17.87±4.07	0.24	318.5±23.2	4.25

The minimum measurable dose (MMD) of the initial dose when using the PTTL and the residual dose methods were determined by plotting the relative standard deviation of the PTTL (figure 1) and residual dose (figure 2) vs. the exposure and fitting to them the expression given by Zarand and Polgar (7,8). The MMD is defined as the dose value where the relative standard deviation is 20%. The values obtained are about 13 mGy for the PTTL and about 360 mGy for the residual dose.

CONCLUSIONS

From the results presented in table 1 and in the figures, the followings can be concluded:

A. For the dose range 0.15 to about 5.0 Gy, the value of the residual dose is a constant fraction of the first reading - $0.13 \pm 0.03\%$. There seems to be an increase of the residual dose for doses above 5.0 Gy, probably due to the supralinearity effect (3).

B. The values of the PTTL in the dose range 0.15 to about 5.0 Gy are a constant fraction of the first reading too ($2.73 \pm 0.44\%$), and the value of the PTTL seems also to increase for higher doses.

C. The PTTL is higher than the residual dose by more than an order of magnitude and its accuracy is better than that of the residual dose.

D. When employing the PTTL method, the MMD of the initial dose is about 13 mGy and for the residual dose method the MMD of the initial dose is about 0.36 Gy.

REFERENCES

1. Cameron, J.R. et al., "Radiation dosimeter utilizing the thermoluminescence of LiF", *Science* 134, 333 (1961).
2. Portal, G., "Review of the principal materials available for TLD", *Rad. Prot. Dosim.*, 13, 351-357 (1986).
3. Horowitz, Y.S., "Thermoluminescence and thermoluminescent dosimetry", CRC Press, Boca Raton, Fla. (1984).
4. Mason, E.W., "Thermoluminescence response of ^7LiF to ultraviolet light", *Phys. Med. Biol.*, 16(2), 303-310 (1971).
5. Mason, E.W., McKinley, A.F. and Saunders, S.D., "The re-estimation of absorbed doses of less than 1 rad measured with LiF TLDs", *Phys. Med. Biol.*, 22(1), 29-35 (1977).
6. Sunta, C.M. and Watanabe, S., "Thermoluminescence of LiF TLD-100 by phototransfer", *J. Phys. D: Appl. Phys.* 9, 1271 (1976).
7. Zarand, P. and Polgar, I., "A theoretical study on the relative standard deviation of TLD systems", *Nucl. Instrum. Meths.*, 205, 525-529 (1983).
8. Zarand, P. and Polgar, I., "On the relative standard deviation of the TLD systems", *Nucl. Instrum. Meths.*, 222, 567-573 (1984).

FIG 1 : THE RELATIVE STANDARD DEVIATION
OF THE RESIDUAL DOSE vs THE EXPOSURE

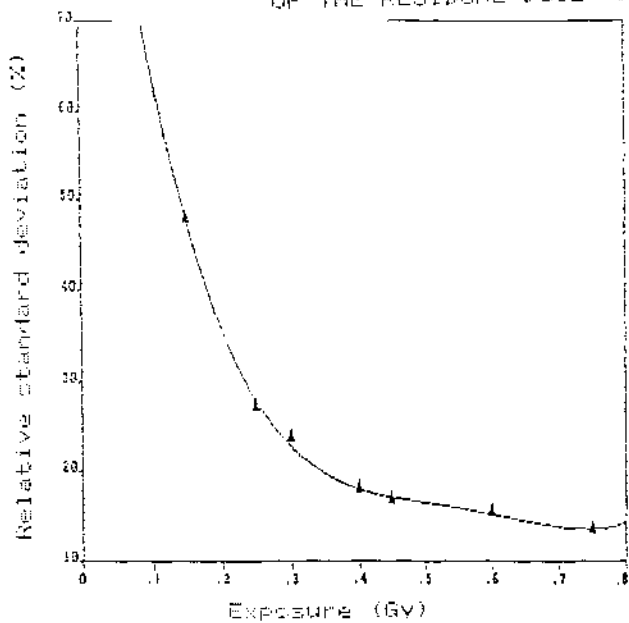
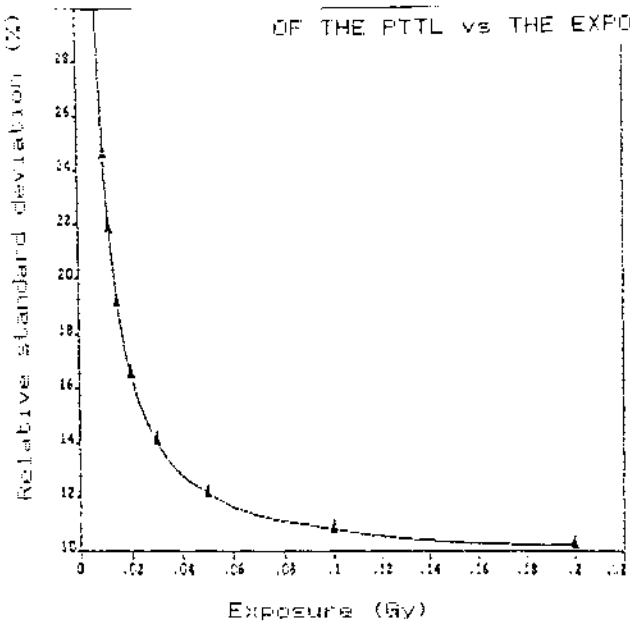

FIG 2 : THE RELATIVE STANDARD DEVIATION
OF THE P TTL vs THE EXPOSURE



MEASUREMENT OF LOW PHOTON EXPOSURES USING A FULL AUTOMATIC PHOSPHATE GLASS DOSIMETRY SYSTEM WITH UV LASER EXCITATION

E. Piesch, B. Burgkhardt, M. Vilgis

Karlsruhe Nuclear Research Centre, 7500 Karlsruhe, Postfach 3640, FRG

ABSTRACT

The full automatic PLD system, to be PTB type tested in 1992, turned out to be superior to TLD systems mainly due to the intrinsic pre-dose suppression which provides dose measurements of 0.1 mSv with a variation coefficient of better than 5%. The results of consecutively irradiated and measured glasses demonstrate linearity and low random uncertainty of dose measurement in the low dose range.

INTRODUCTION

Retrospectively, the high pre-dose and the energy dependence of phosphate glass dosimeters prevented a large scale application of glass dosimetry so far. The most important progress of the last years have been found in the pulsed UV laser excitation of glasses which reduced the pre-dose dramatically (1). In the mean time, the modern, commercially available, full automatic Toshiba read-out systems FGD-10 and FGD-20 are expected to be reliable dosimetry systems for a large scale application in personnel and environmental monitoring (2,3).

With respect to the capability of measuring low doses within routine monitoring, it was of special interest to investigate linearity and random uncertainty of dose measurement in the low dose range.

DOSIMETRY SYSTEM

The flat glass dosimeter consists of a plastic encapsulation ($4 \times 3 \times 0.8$ cm³) with energy compensation filters on both sides and a glass element ($16 \times 16 \times 1.5$ mm³) fixed in a stainless steel card. The dosimeter is locked magnetically. In the PLD system Toshiba FGD-10 the automatic read-out includes: (a) opening and closing of the dosimeter, (b) reading of ID-No for capsules and cards, respectively, (c) exchange of high dosed by annealed glass cards during read-out, (d) the continuous reading of up to 500 dosimeters, (e) the calibration of the reader and (f) the print-out of the results.

Pulsed UV laser excitation reduces the pre-dose down to 30 μ Sv. The energy response of the flat glass dosimeter in Table 1 are recent results of an IAEA inter-comparison experiment using frontal irradiations on a slab phantom and the read-out in terms of $H'(10)$. After the PTB type test in 1992, the commercially available PLD system will be introduced in Germany as a governmental dosimeter within routine personnel monitoring.

The PLD system, now comparable with the best TLD systems regarding the lowest detectable dose, the dose range (0.03 mSv to 3 Sv) and the energy and angular response (10 keV to 3 MeV), is, however, superior with respect to the capability of repeated read-outs, the simultaneous indication of different dose quantities (exposure X or $H'(10)$) using the same irradiated dosimeter, and with respect to the interpretation of the read-out in terms of radiation quality and radiation incidence.

PRE-DOSE SUPPRESSION AND RANDOM UNCERTAINTY IN THE LOW DOSE RANGE

Fig. 1 illustrates the read-out after UV pulse excitation of an unirradiated and irradiated glass. During the read-out, the time dependent PL intensity $I(t)$ is integrated in two different periods, namely the short-term component (total reading) in the period between 2 - 7 μsec , and the irradiation independent, long-term component of the residual reading in the period between 40-45 μsec . A multiple f_{ps} of the measured residual reading is subtracted from the total reading resulting in the radiation induced reading M . The "pre-dose suppression factor" f_{ps} is measured only once after the initial annealing.

The internal pre-dose suppression during each read-out reduces the pre-dose value of the conventional UV excitation of 1 mSv by two order of magnitudes to about 0.03 mSv and also renders glass cleaning unnecessary.

Fig. 2 compares the frequency distribution of the variation coefficient, (a) for the pre-dose of dosimeter batches (mean value 25-35 μSv) after 15 times of re-use immediately after oven annealing at 400°C, and (b) for a 10 times daily reading at 6 mSv. The mean value of the variation coefficient was found to be 6.7 % (2 μSv) for the pre-dose of 30 μSv of annealed glasses and 0.46% (28 μSv) for a dose of 6 mSv of an irradiated calibration glass. On the basis of these data, the variation coefficient for the dose reading was calculated and presented in Fig. 3 as a function of the uncorrected dose reading $H_U = H + H_0$ as well as after subtraction of the individual pre-dose H_0 of about 0.03 mSv or of an accumulated "pre-dose" of 3 mSv as a function of the dose accumulated in the actual monitoring period. Using an annealed glass dosimeter, the variation coefficient for a dose measurement at 0.1 mSv was found to be 3%, at 3 mSv only 0.5%.

CONSECUTIVE MEASUREMENTS IN INDIVIDUAL MONITORING

The glass dosimeter reading is the total dose accumulated since the last annealing. During routine monitoring, personal dosimeters accumulate the natural radiation background and additional contributions of occupational exposures.

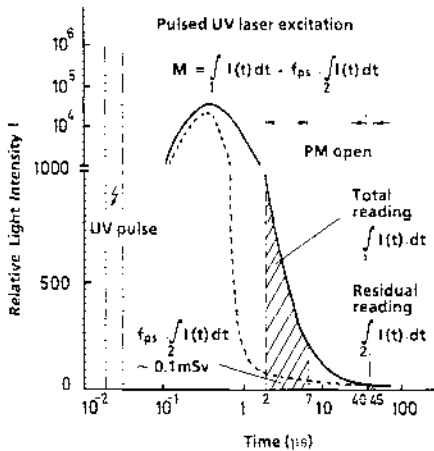

Tab. 1 Glass dosimeter results, 1990 IAEA intercomparison for Individual Monitoring

E (keV)	H / H'(10,0°)
20	0.94
37	0.98
57	1.01
104	0.97
205	0.93
374	0.96
662	1.04
1250	0.99
mean ± max/min	0.985 ± 5.5%

Fig. 1 Subtraction of the residual dose reading of PL dosimeters using pulsed UV laser excitation

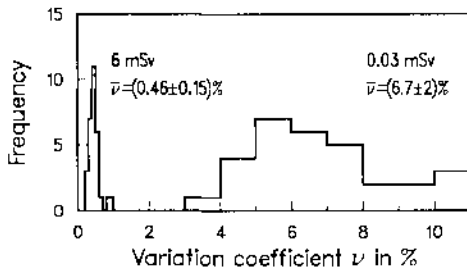

Fig. 2 Frequency distribution of the variation coefficient for the pre-dose (mean value 0.03 mSv) of annealed glass dosimeter batches and the repeated readings of the calibration glass.

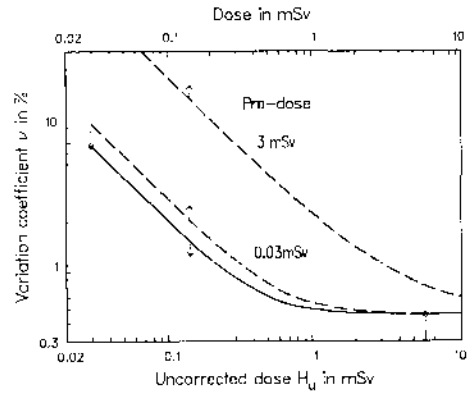

Fig. 3 Variation coefficient of the dose measurement using the same glass dosimeter vs. the uncorrected dose H_u and the measured dose $H = H_u - H_0$ at pre-doses of 0.03 and 3 mSv.

The actual dose contribution of the last monitoring period is given by the difference of two consecutive measurements at the beginning and the end of the monitoring period of usually 1 month.

Batches of glass dosimeters have been irradiated and measured consecutively over periods of more than three months using low exposures in steps of 0.05 mSv and 0.1 mSv, respectively. Fig. 4 shows for the consecutive measurements the ratio of the actual dose and the reference dose. For all exposures the mean values have been found to be within $\pm 1.3\%$. This scatter can be interpreted as the long-term

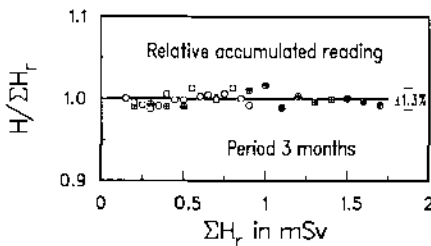

Fig. 4 Ratio of the actual dose reading and the reference dose for repeated irradiations of a batch vs. dose. Mean value of 8 dosimeters.

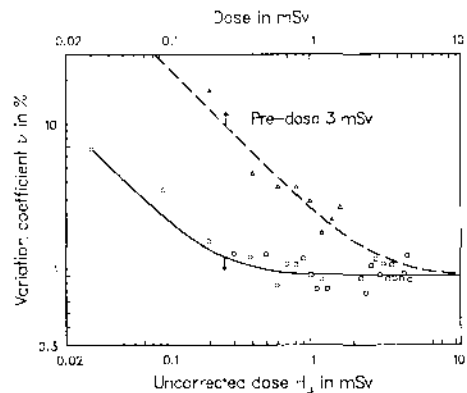

Fig. 5 Variation coefficient of the dose measurement using a batch of 10 dosimeters within vs. dose.

instability of the dosimeter system, including errors of the consecutive irradiations of the batches and the repeated reader calibrations using the calibration glass. In the upper dose range, the variation coefficients for dosimeter batches (Fig.5) are slightly higher by about 0.4% to those for one glass only (Fig.3), because of the small scatter in the photon response of individual glass detectors within the batch. In the case that the total accumulated "pre-dose" is 3 mSv, a contribution of 0.1 mSv of the last monitoring period can be measured with a variation coefficient of 25%.

MEASUREMENT OF THE NATURAL RADIATION BACKGROUND

In a similar experiment, a dosimeter batch was exposed to the natural radiation background and measured consecutively over a period of 3 months starting with a pre-exposure of 0.1 mSv. For all read-outs, the variation coefficient for the mean value of 8 detectors was smaller than 2% (4% for two detectors). Within environmental monitoring, the dosimeter pair usually used may indicate the natural radiation background already after 10 days with a random uncertainty of about 25%. Because annealed glasses are used for environmental monitoring, only the intrinsic pre-dose of 0.03 mSv will be subtracted. The corresponding variation coefficient for a single detector reading is shown in Fig. 3 as a function of the accumulated dose.

CONCLUSION

PLD systems, unlike other systems, do have the capability of combining, on the one hand, repeated read-outs at any time during the monitoring period by the user and, on the other hand, control measurements after long-term monitoring periods by independent services of the authorities with a relatively high precision of 1% as already demonstrated for the UV excitation with Hg lamps (4).

The full automatic PLD system, now improved and commercially available offers an unexpected new approach in routine monitoring and the breakthrough of a technique, so far neglected but now a potential alternative in personnel and environmental monitoring.

REFERENCES

- (1) Piesch, E., Burgkhardt, B., Fischer, M., Röber, H.G. and Ugi, S., 1986, Properties of Radiophotoluminescent Glass Dosimeter Systems using Pulsed Laser UV Excitation, *Radiat. Prot. Dosim.*, 17, 293-297.
- (2) Piesch, E., Burgkhardt, B. and Vilgis, M., 1990, Photoluminescence Dosimetry-Progress and Present State of the Art, *Radiat. Prot. Dosim.*, 33, 215-226.
- (3) Burgkhardt, B., Vilgis, M., Piesch, E., Ishidoya, T. and Ikegami, T., 1990, Modern Automatic Read-out Systems for Phosphate Glass Dosimeters Using UV-laser Excitation, *Radiat. Prot. Dosim.*, 34, 369-372.
- (4) Regulla, D. and Piesch, E., 1984, One-element Personal Dosimeter for Local and Centralized Evaluation, *Radiat. Prot. Dosim.*, 6, 363.

PROTECTION CONTRE LE BREMSSTRAHLUNG
SUR MOLECULES RESIDUELLES DE LA CHAMBRE A VIDE
D'UN ANNEAU DE STOCKAGE D'ELECTRONS OU DE POSITONS
DANS UN CENTRE PRODUCTEUR DE RAYONNEMENT SYNCHROTRON

J.C. FRANCK

Laboratoire pour l'Utilisation du Rayonnement
Electro-magnétique (LURE)
Université Paris-Sud
91405 ORSAY (France)

PROTECTION AGAINST BREMSSTRAHLUNG
DUE TO OCCURENCE OF RESIDUAL MOLECULES
IN THE VACUUM CHAMBER OF AN ELECTRON-OR-POSITRON
STORAGE RING IN A SYNCHROTRON RADIATION FACILITY

This parasitic phenomenon, which produces an important absorbed dose rates (more than ten milligrays per hour at the distance of 10 meters from the point-source emitter) is disturbing because it takes the same way as the synchrotron radiation produced by the insertion device.

This Bremsstrahlung develops itself in a very narrow cone downwards the insertion device and along its axis; its maximum energy is similar to the energy of the stored electrons or positrons (at LURE : 800 and 1850 MeV) and its absorbed dose rate is proportionnal to the stored particles (350 mA) and the pressure in the vacuum chamber (10^{-8} Pa).

Besides the calculations of this absorbed dose rate, we describe the way to calculate the beam catchers which thickness is always important (more than 10 cm of lead blocks), as well as the mode of elaboration of these shieldings within the very peculiar framework on the use of a synchrotron radiation.

INTRODUCTION

Le Bremsstrahlung créé par l'interaction entre les électrons ou positons stockés et les molécules résiduelles de la chambre à vide d'un anneau de stockage est un phénomène parasite préoccupant pour les expérimentateurs qui utilisent le rayonnement synchrotron issu d'un élément d'insertion (onduleur ou wiggler) installé dans une section droite de l'anneau.

Dans ce cas, en effet, le cheminement du rayonnement synchrotron est le même que celui du Bremsstrahlung; celui-ci se développe dans un cône très étroit en aval et dans l'axe de l'élément d'insertion et a pour énergie maxima l'énergie des particules stockées (à LURE, DCI: 1850 MeV; SUPER ACO: 800 MeV). (Figure 1)

Le débit de dose qu'il crée est important (un à plusieurs dizaines de milligrays par heure à 10 mètres du point source); il est proportionnel, notamment, aux particules stockées (350 mA à LURE) et à la pression régnant dans la chambre à vide de l'anneau (10^{-8} Pa).

La protection des expérimentateurs contre ce phénomène est particulièrement délicate : elle doit être efficace et ne gêner en rien l'expérimentateur qui utilise le rayonnement

synchrotron. Lorsqu'il s'agit de blocs d'arrêt, ils ont toujours une épaisseur importante (une ou plusieurs dizaines de centimètres de plomb par exemple).

Après un rappel du calcul du débit de dose maximum D_0 à ce Bremsstrahlung, nous présenterons les protections que nous avons mises en place à LURE autour des anneaux DCI et SUPER ACO et nous commenterons leur efficacité.

CALCUL DU DEBIT DE DOSE ABSORBEE MAXIMUM

Ce débit de dose maximum (D en $Gy\cdot h^{-1}$) au point cible peut être estimé à partir de l'équation suivante :

$$D = \frac{fN}{\pi\alpha^2 X_0} \frac{x}{L(x+L)}$$

où

f : débit de dose par unité de débit de fluence photonique à l'énergie maxima du Bremsstrahlung (mesure conservatoire) $Gy\cdot h^{-1} \gamma^{-1} cm^2 s$ (ICRP publication 21)
à 1850 MeV, $f = 2,2 \cdot 10^{-6}$ à 800 MeV, $f = 2 \cdot 10^{-6}$

N : débit d'électrons ou de positons en un point de l'anneau de stockage ($e^+ s^{-1}$ ou $e^- s^{-1}$)
pour 350 mA $N = 2,2 \cdot 10^{18}$

α : $\frac{0,511}{E_0}$ rd (E_0 : énergie (MeV) des particules stockées)
à 1850 MeV $\alpha = 2,8 \cdot 10^{-4}$ à 800 MeV $\alpha = 6,4 \cdot 10^{-4}$

X_0 : longueur de radiation dans l'air (cm)
à 10^{-8} Pa $X_0 = 3 \cdot 10^{17}$

x : longueur d'une section droite d'un anneau (cm)
DCI (1850 MeV) $x = 650$ SUPER ACO (800 MeV) $x = 770$

L : distance fin de section droite - point cible (cm)
DCI, $L = 1600$ SUPER ACO, $L = 1000$ (exemple)

A LURE ce débit de dose maximum estimé est de l'ordre de :
DCI : $1,2 \cdot 10^{-2} Gy\cdot h^{-1}$ SUPER ACO : $5,2 \cdot 10^{-3} Gy\cdot h^{-1}$

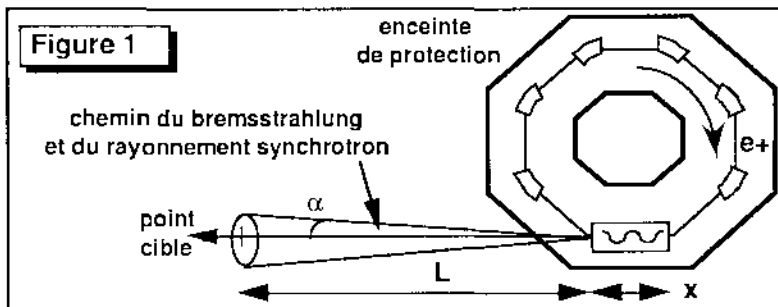

PROTECTIONS MISES EN PLACE A LURE CONTRE LE BREMSSTRAHLUNG

Elles reposent sur la mise en place de blocs d'arrêt au plus près de la source dès lors qu'elles ne gênent pas le cheminement utile du rayonnement synchrotron.

Les dimensions de ces blocs sont déterminées par mesure conservatoire en ne retenant que le débit de dose maximum au point-cible pour un stockage maximum de particules dans l'anneau et une exposition maxima de personnes du public au point le plus critique: Elles sont calculées longitudinalement en utilisant exclusivement le libre parcours moyen maximum des photons dans le matériau utilisé (Béton:21; Plomb:2,1; Tungstène:1,3 (en cm)) et transversalement les longueurs de Molière (Béton:13; Plomb:1,6; Tungstène:0,93 (en cm)); si nécessaire un puits est aménagé sur la face avant du bloc d'arrêt pour limiter les problèmes de rétrodiffusion.

Premier cas (DCI): nombre pair de lignes de rayonnement synchrotron (RS) issues du même élément d'insertion

Dans ce cas un bloc d'arrêt mobile nommé "Piège à gamma neutrons (PGN)" situé à l'intérieur de l'enceinte de protection qui contient l'anneau et dont la fonction est d'obturer le passage des lignes RS à travers cette enceinte lors du remplissage de l'anneau est muni d'une pièce rapportée en tungstène; lorsque le PGN s'efface pour l'utilisation du rayonnement synchrotron, cette pièce fait obstacle au Bremsstrahlung (figure 2). Des mesures de débit de dose ont montré l'efficacité de ce dispositif ($D < 1 \mu\text{Gyh}^{-1}$).

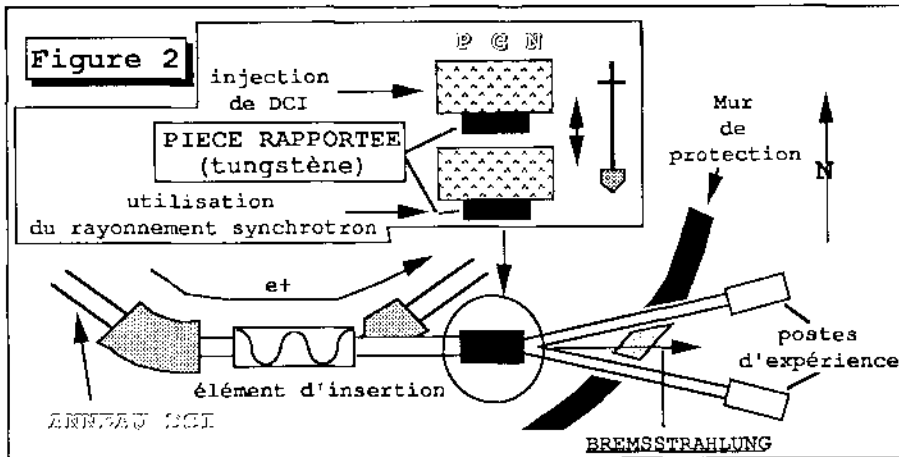

Deuxième cas (SUPER ACO): nombre impair de lignes de rayonnement synchrotron issues du même élément d'insertion

Dans ce cas un bloc d'arrêt fixe est installé hors de l'enceinte de protection juste en aval d'un dispositif de déviation du rayonnement synchrotron (miroir ou monochromateur) (figure 3). Des mesures du débit de dose à l'aide d'une chambre d'ionisation juste en amont et en aval d'un tel bloc d'arrêt ont montré son efficacité (source-point cible:12m; E_0 :800 MeV; I:350 nA; plomb:25 cm; $D=8000$ (juste en amont), $D < 1 \mu\text{Gyh}^{-1}$ (juste en aval) du bloc d'arrêt).

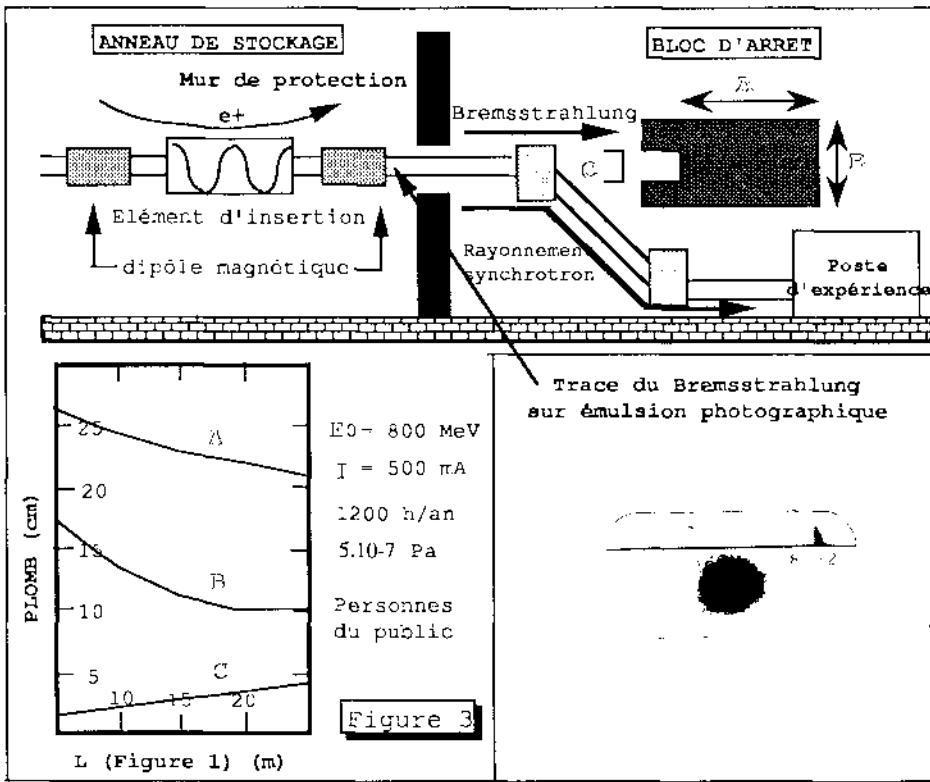

CONCLUSIONS

La maîtrise de la protection contre ce Bremsstrahlung n'est parfaite que dans le cas d'un nombre pair de lignes de rayonnement synchrotron issues d'un même élément d'insertion: pièce rapportée sur PGN situé dans l'enceinte de protection.

Elle est satisfaisante dans le cas contraire si la rétrodiffusion au niveau du bloc d'arrêt et la diffusion le long de la ligne centrale RS ne donnent pas de débits de dose inacceptables pour des personnes du public; si tel est le cas, des mesures complémentaires de protection s'imposent (ex: obstacles empêchant l'approche de la ligne RS).

Enfin le protocole de calcul des blocs d'arrêt utilisé à LURE et qui est conservatoire est parfaitement validé par les mesures de débit de dose effectuées autour des points-cible.

BIBLIOGRAPHIE

1. Rindi, A., 1982, gas Bremsstrahlung from electron storage ring, Health Physics, 42, pp.187-193
2. Esposito, A., Pelliccioni, M., 1986, Gas Bremsstrahlung production in the Adone storage ring, LNF-86/23(NT) Frascati (Roma) Italiana

THE URINALYSIS INTERCOMPARISONS ADMINISTERED BY CANADA'S NATIONAL REFERENCE CENTRE FOR RADIOBIOASSAY - HAVE THEY MADE A DIFFERENCE?

M. LIMSON ZAMORA, M. GODDARD, R. FALCOMER, W. HUNT AND G. MOODIE

BUREAU OF RADIATION AND MEDICAL DEVICES
DEPARTMENT OF NATIONAL HEALTH AND WELFARE
OTTAWA, CANADA

ABSTRACT

The Bureau of Radiation and Medical Devices has acted as Canada's National Reference Centre for Bioassay and *in vivo* Monitoring since 1983. The Centre provides quality assurance to organizations performing *in vitro* radiobioassay, including urinalysis intercomparisons for uranium, tritium, and carbon-14. Evaluation of results has shown that regular participation has resulted in a steady improvement in analytical performance. Bias between the true value and reported results has been reduced, and precision enhanced.

BACKGROUND

The assessment of the dose from the intake of radionuclides is a two-step process. The first step involves either directly measuring the individual suspected of over-exposure, or measuring his excreta, the matrix of choice usually being a urine specimen. The second step is the conversion of the measurement to a dose through the use of an appropriate metabolic model. It follows then that, given a good metabolic model, the quality of a dose estimate would depend ultimately on the quality of the measurements used for its calculation.

Licensees of the Atomic Energy Control Board (AECB), Canada's regulatory agency, are distributed across the country. To ensure comparability of the measurement data generated by these organizations, the AECB in 1982 approved a policy requiring all its licensees to calibrate, on a regular basis, devices and systems used in estimating radiation dose, and to demonstrate the traceability of such calibrations to AECB-approved national standards. While suitable standards existed in Canada at the time to meet these requirements for some licensed operations, e.g., those which made use of gamma-radiation, there were other operations and areas for which no suitable practical standards existed. These areas included bioassay, for which the AECB in 1983 designated the Bureau's Bioassay Section and Human Monitoring Laboratory to act as the National Reference Centre with a mandate to develop and provide programs and practical reference standards for measurements used in the assessment of internal dose. The working group, organized to address the technical questions associated with the development of such standards, recommended [1] that "measurement traceability" which includes instrument performance, analyst proficiency and the procedures used, be the mechanism by which bioassay laboratories demonstrate their capabilities on a continuing basis to the AECB.

EXISTING PROGRAMS

With these recommendations in mind, the Bureau has established and administers three urinalysis intercomparisons: (1) Uranium, which has been in place since 1978, and was re-structured in 1983 to allow the assessment of precision as well as the bias of submitted results, (2) Tritium and (3) Carbon-14 which were established in 1985 and 1986, respectively. The Uranium and Tritium Programs have been available semi-annually, while the Carbon-14 Program is offered annually. Urine standards are prepared in-house containing radionuclides in the range commonly encountered in specimens measured by participating laboratories, as well as concentrations cited as "Derived Investigation or Action Levels" in the criteria documents [2,3] published by the Federal-Provincial Working Group for Bioassay and *in vivo* Monitoring Criteria. Performance is tested at three radionuclide concentrations which are unknown to the participants. To determine a laboratory's ability to reproduce results, five aliquots of each concentration are sent to each participant. As noted above, samples are distributed on a regular basis, since satisfactory performance cannot be reasonably guaranteed over an indefinite length of time. Participants are asked to return their analytical results to the Reference Centre within thirty days of receipt of samples. Results are evaluated with respect to bias and precision, and a final report is sent to all participants regarding their performance. Anonymity is maintained by assigning a code to each laboratory. The AECB is in the process of setting performance criteria for bioassay measurements. In the interim, the Centre uses the following limits for the acceptability of results:

- 1 to 10 AMDA: $-.50 \leq \text{Relative bias} \leq .25$
Relative precision $\leq .40$
- 10 to 100 AMDA: $-.25 \leq \text{Relative bias} \leq .25$
Relative precision $\leq .25$

Acceptable Minimum Detectable Amount (AMDA) values are those cited in the Bioassay Guidelines [2,3].

BENEFITS DERIVED FROM PARTICIPATION

A primary benefit derived from participation is the opportunity to obtain external verification of one's results. This is illustrated in Table 1 below. The participant obtained excellent precision for the measurement of the intercomparison standards distributed in December 1983. However, the measurement bias was large and for the 79 μg spike, exceeded the acceptable relative bias limit. The problem was not the instrument or the analytical procedures in use, but the laboratory standard. After changing to a certified standard, accuracy improved tremendously, as shown by the July 1984 results.

Some laboratories have also used the sample sets that we provide to compare the performance of analysts on their staff. Because we ensure the homogeneity of the samples that we distribute, these laboratories can be sure that they are making a valid comparison between analysts who are measuring the same radionuclide concentrations in the same sample matrix. At times, as many as three analysts have participated in the intra-laboratory intercomparison exercise.

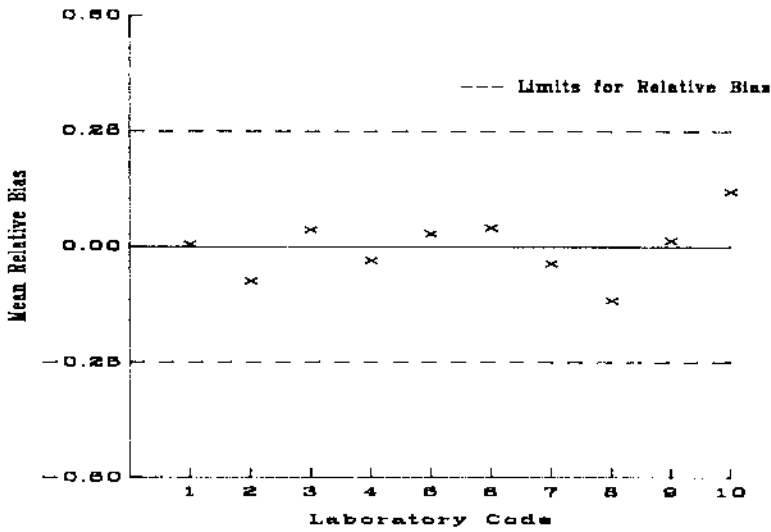

Fig. 1. Tritium in Urine Intercomparison mean relative bias chart.
Spike Level = 9.29×10^4 Bq/L

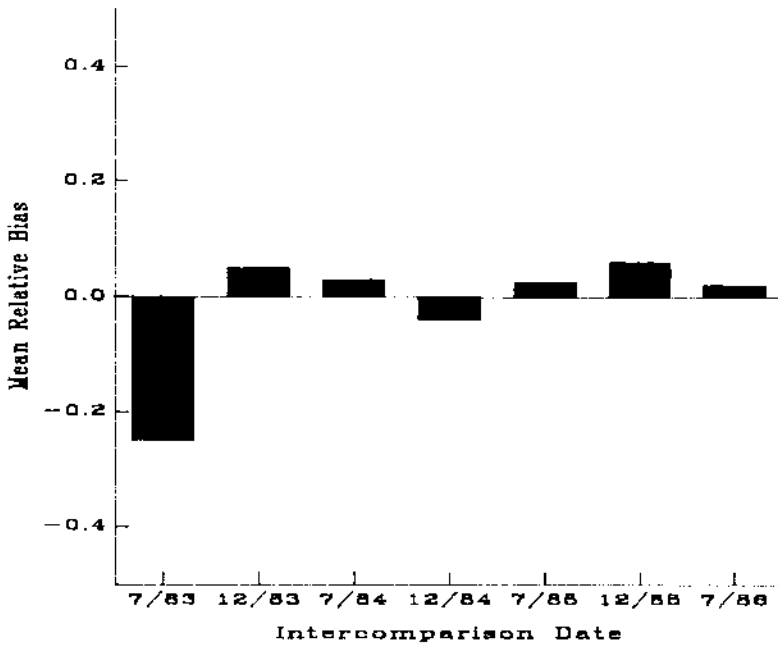

Fig. 2. Improvement and sustained good performance of a Uranium Urinalysis Intercomparison participant.

TABLE 1
Uranium in Urine Intercomparison Results for Participant A

Date	Spike ($\mu\text{g/L}$)	Mean Relative Bias	Relative Precision
December 1983	47.62	-.404	.039
	79.00	-.408	.024
July 1984	51.35	-.040	.030
	75.27	.071	.031

Of particular interest to the AECB is the validity of results and their comparability between licensees. Figure 1 is a chart taken from the report for the September 1991 Tritium Intercomparison. It provides a quick appraisal of how each licensee compares to other laboratories who have analyzed identical radionuclide levels, as well as whether or not the mean relative bias of submitted results are within acceptable limits. Final reports include similar charts for precision.

All intercomparison results submitted to the Centre to date, as well as data on the evaluation of measurement performance have been stored in a historical data base. The performance of a Uranium Intercomparison participant over a three-year period is charted in Figure 2. The concentrations measured were equal to or greater than the Derived Investigation Level cited in the Uranium Bioassay Guideline [3] for Class D uranium. This laboratory had close to unacceptable negative bias in July 1983, but after several consultations with Reference Centre staff regarding analytical techniques, showed dramatic improvement in accuracy in the December 1983 intercomparison, which was maintained through 1986, and thereafter.

This trend of improvement and sustained good performance with regular participation has been demonstrated with almost all participants. Any observed lapses usually occur when new staff are hired, or new measurement procedures are implemented. Generally, however, bias and precision are well within the acceptable limits. Feedback provided in the reports has given the participants confidence in their measurement capabilities and bolstered their credibility in the eyes of the employees that they monitor.

REFERENCES

1. Working Group for the Development of Practical Calibration Standards for Bioassay and *in vivo* Monitoring, 1982. Report to the AECB.
2. Guidelines for Tritium Bioassay, 1983. Report of the Federal-Provincial Working Group on Bioassay and *in vivo* Monitoring Criteria. Health and Welfare Canada, 83-EHD-87.
3. Guidelines for Uranium Bioassay, 1988. Report of the Federal-Provincial Working Group on Bioassay and *in vivo* Monitoring Criteria. Health and Welfare Canada, 88-EHD-139.

EVALUATION OF SURFACE CONTAMINATION BASED ON CERTIFIABLY
TRACEABLE, INTERNATIONALLY ACCREDITABLE MEASUREMENTS

Mr. G. D. Whitlock

Hughes Whitlock Ltd.
PO Box 22, Malvern, Worcs.
England WR13 6SL

ABSTRACT

National Accreditation and Measurement Service (NAMAS) adopted by the EUROMET agreement requires that the calibration of monitoring instruments be traceable internationally with the objective that radiation hazard assessment be improved. This objective is achieved for Tritium surface contamination by employing calibration sources and evaluation methods which comply with ISO standards including the measurement of activity removable by volatilisation as well as dust. Consideration should be given to organic binding of Tritium in the skin with its implications in the event of litigation.

INTRODUCTION

The basis of Radiological Protection is currently in a state of change. A requirement of the new ICRP regulation relates hazard to individuals instead of collective dose. Most European countries have signed the EUROMET agreement, by which the calibration of Monitoring Instruments has to be traceable to NAMAS accredited calibration laboratories with the objective that radiation hazard assessment be improved as a consequence of being based upon creditable measurements. Independently, standards organisations pursue the same logic and have produced ISO 8769-"Reference Sources" and ISO 7503-"Evaluation of Surface Contamination", which describe the calibration and the method.

Individually and collectively this calls for a review of radiological protection practices to meet these new demands if only to show evidence of competence in the event of litigation. Current legislation requiring the measurement of activity removable (which detaches) from the surface in normal use can not be satisfied by measuring only active dust. Many forms of Tritium contamination are volatile, and removal by volatilisation has to be accounted for particularly as it presents a greater hazard than removable dust. Research has shown localised organic binding of Tritium in organs of the skin¹, and the implications of this should be considered.

Using the evaluation of surface contamination by Tritium as an example, the practical application of the regulations, national objectives, and associated international standards are covered in the following protocol.

THE REFERENCE SOURCE

A reference source with a certified emission rate traceable to measurements by a national standards laboratory has to be of a form which accords to ISO 8769 "Reference Sources".

A Tritium source constructed to this standard is available. Its size is 100 mm x 150 mm, and the activity has been deposited by the Langmuir-Blodgett technique in the form of a homogeneous monolayer of tritiated molecules². There is therefore, no self absorption, and the classic spectrum of energies of the emitted beta particles is unmodified other than by backscattered betas the effect of which can be calculated. Figure 1.

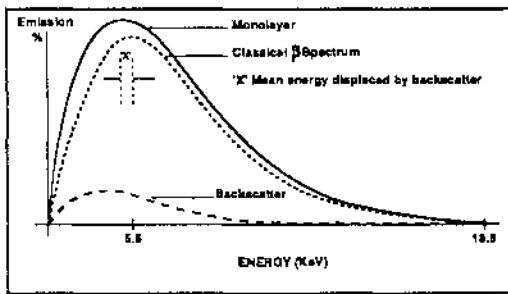

Fig. 1. Monolayer Tritium Beta Emission Spectra

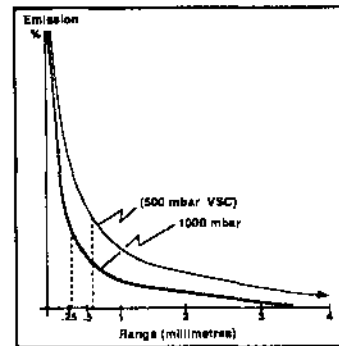

Fig. 2. Tritium Beta Absorption in Air

The source has to be suitable for calibrating all manner of Tritium surface contamination measuring instruments, and should not introduce distance variation errors into the calibration. This calls for a surface flatness of ± 0.025 mm because, even though the maximum range in air of the measuring energy Tritium beta (18.6 KeV) is approximately 4 mm, the mean range of Tritium betas is only 0.25 mm (approximately half the thickness of a finger nail). Figure 2. This source is used to establish a valid calibration of the measuring instrument.

THE SURFACE MEASURING INSTRUMENT

The instrument must be so constructed that the conditions and geometry for calibration measurements can be reproduced identically or within a predictable approximation when taking measurements of the surface.

Essentially, the detector must be sensitive to the low energy Tritium betas. This means that no protective or gas retaining "window" can be incorporated because even the maximum energy beta (18.6 KeV) is absorbed in 8 microns (10^{-6} M) of unit density material, and the mean range of the beta emission is 0.2 microns.

In addition, the International Standard ISO 7503 "Evaluation of Surface Contamination Part 2 Tritium" shows a

detector with a minimum area of 100 cm² is preferred. An instrument, which meets all these requirements is the Hughes Whitlock Ltd. Vacuum Scintillation Counter (VSC).

ACTIVITY PER UNIT AREA

Estimating the surface contamination level, in terms of activity in Bq cm⁻² from the number of emissions recorded as counts by the measuring instrument, requires careful consideration.

Prior to decontamination, the source may be infinitely thick in terms of Tritium contamination. The method used for decontamination might itself have caused the formation of thick sources because dissolving the activity in a solvent could change its form to one likely to be absorbed by the surface.

Although in these circumstances, direct measurements do not enable the calculation of activity cm⁻², they do indicate activity build up and reveal the need to decontaminate the surface as well as promote more diligent and or alternative decontamination techniques. Normally, after decontamination, the form of the contamination remaining on surfaces acceptable for radiological purposes then approximates to the monolayer calibration source³ and the measurements are traceable.

EVALUATION BY WIPE ASSAY

Where the surface is not flat enough to make direct measurements, wipe assay is used but they should be made according to ISO 7503, which requires that a wipe collection factor be established.

The 10% collection factor can only be applied to indicate the presence of active dust on smooth, non-porous surfaces. It cannot be assumed to apply to all removable activity, and certainly not to total activity assessment. Care should be taken that the collected dust does not produce a thick source on the wipe or be absorbed into it as these states can cause gross measurements errors.

When an acceptably flat area for direct measurement can not be found, wipe collection factors can still be obtained by preparing a facsimile of the surface, and applying experimental quantities of activity for direct measurement and wipe assay.

REMOVABLE ACTIVITY-DUST AND VOLATILES

'Removable' activity is that which can be caused to be detached from the surface by any working practice. This does not allow the evaluation of 'removable' to be confined to the evaluation of only dust particles. Dust is a form of activity that is 'removable' but a form of 'removable' that should be of greater concern is volatile activity. Volatile fractions can be released (removed) by a change in temperature or

pressure e.g. the heat from a hand placed on the surface. Inhalation and ingestion routes are the same as for dust. In addition, in the case of Tritium, it can be absorbed through the skin over the whole body surface.

It has been shown that organic binding of Tritium takes place in the skin particularly in the region of the glands e.g. hair follicles¹. Tritium betas emitted from these sites >8 microns from the surface are not detectable externally, and would not show in urine measurements because any slow exchange would be masked by the rapid excretion rate of the majority of inhaled or absorbed activity. The regulatory requirement to monitor 'removable' activity automatically embraces volatiles as well as dust as a removable form. Making the measurements to meet the regulations is the licensee's responsibility.

DETECTING VOLATILE ACTIVITY

During measurement, the VSC creates a partial vacuum (500 millibars) in the measuring chamber, one part of which is the surface being measured. If a volatile form of Tritium is present, the reduced pressure causes volatilisation to take place, and diffusion to occur in the contamination and surface materials. Air absorption is reduced, and the change in geometry is detected by the instrument to differentiate volatiles from other surface contamination.

CONCLUSIONS

Current practices in Radiation Protection do not satisfy the legislative requirement to measure activity removable by all means. Accredited measurements using Certified Sources and International Standard methods not only satisfy legislation but create a less hazardous working environment supporting the ALARA principle. The means are available and there is no excuse in the case of litigation for not applying them.

ACKNOWLEDGEMENTS

The author thanks the American Nuclear Society for permission to publish extracts from his two papers presented at the Fourth Topical Meeting. Copyright 29 September 1991 American Nuclear Society, La Grange Park, Illinois, USA

REFERENCES

1. A. TRIVEDI, J.W. LEON, C.A. BARR, R.G.C. McEIROY, "Skin-Contact Exposure to Tritium on Stainless-Steel Surfaces," Proceedings of Tritium and Advanced Fuel in Fusion Reactors, Varenna, Italy, 1989
2. P.J. BALLARD, M.F. DANJEL, G.D. WHITLOCK, "An Ultra-Thin Tritium Source Standard for Instrument Calibration," Proceedings 5th Congress IRPA, Berlin, Germany, 1987
3. J.R. MAJER, "A New Method of Assessing the Efficiency of Decontamination of Surfaces," Process Biochemistry

APPLICATION OF THIN MEMBRANE SOURCES FOR PREPARATION OF β -RAY
DOSE CALIBRATION SOURCES IN SKIN CONTAMINATION MEASUREMENT

Makoto YOSHIDA, Hiroyuki MURAKAMI and Kazuyoshi BINGO

Japan Atomic Energy Research Institute
Tokai-mura, Naka-gun, Ibaraki-ken, Japan

ABSTRACT

The application of thin ion-exchange membrane sources was studied for preparation of β -dose calibration sources in skin contamination. The preparation method, the dose calibration method by an extrapolation chamber and the backscattering effect of backing materials were discussed. The membrane sources are suitable for preparing the calibration sources.

INTRODUCTION

In the nuclear facilities where unsealed radioactive materials are handled, skin contamination with β -ray emitting nuclides can happen to workers. It is very important in the practices of radiation protection to properly estimate the skin dose for the worker. The dose estimation has been so far carried out on the basis of both activity measurement of skin contamination sources and skin dose calculation from the activity¹⁾. This manner is complicated and sometimes includes large errors for the estimation.

It is very convenient that the skin dose can be directly estimated through the β -ray measurement over skin surface with the instruments sensitive to β -rays. Then, it is demanded that the readings of instruments are well related to skin doses. For the purpose, proper calibration sources are needed to deal with routine calibration works.

In the β -dose calibration of personal monitors and surveymeters, in general, the dose is determined by keeping some distance between β -ray sources and instruments. However, in determination of the dose for skin contamination, the source surface must be directly in contact with a window of extrapolation chamber. This situation makes some requirements for preparation of the calibration sources for dose evaluation in skin contamination.

We have already reported a preparation method of relatively thin sources with ion-exchange membranes^{2,3)}. This method can provide large film-like plastic sources whose characteristics are able to meet the requirements mentioned above. In the present paper, the application of the membrane sources to the dose calibration sources has been studied.

EXPERIMENTS

(Preparation of membrane sources)

When skin tissue exposes to the β -rays from skin contamination sources, there is no backing material for the sources but air. For the reason, the skin dose from the sources need be determined without backing materials as well. On the other hand, when

the β -rays are measured outside the tissue with β -ray sensitive instruments, the backscattered β -rays by the tissue should be taken into account. In order to develop the dose calibration sources satisfying these conditions, a thin self-supported source is necessary and can be prepared with ion-exchange membranes.

The membrane sources were prepared with homogeneous polyethylene cation-exchange membranes whose thickness was 3 to 5 mg/cm². These ion-exchange membranes uniformly adsorb radioactive ions under the optimum conditions of carrier concentration, soaking time, hydrogen ion concentration (Ph) and temperature.⁴⁾ Two radioactive nuclides of ²³⁴Tl and ⁹⁰Sr-⁹⁰Y were used for this experiment. The initial size of the membranes on soaking was 20cm x 20cm.

The membranes were soaked for 2 days in radioactive solutions at the temperature of 29°C. On removal from the solution, they were rinsed several times with distilled water to wash off unfixed activity from the surface and dried at room temperature between filter papers. Finally they were mounted in drum-like shape on a brass ring. This way easily provided a flat source without corrugation.

(Uniformity of membrane sources)

Radioactivity distribution of the membrane sources was estimated by autoradiography with industrial X-ray film. The membrane source on the mount ring was directly in contact with X-ray film. The exposure time is about one day. The optical density of the exposed area of X-ray film was measured by a density-meter with a 2mm dia. aperture. The total number of measured positions is more than 50 (2 positions per cm²).

(Extrapolation chamber)

The extrapolation chamber used for determining 7 μ m dose equivalent rate to the membrane sources was designed in accordance with the recommendations of International Organization for Standardization (ISO)⁴⁾. The cross-sectional view of the extrapolation chamber is shown in Fig.1. The entrance window is a carbon coated polyester sheet of 6.37mg/cm² thick. The a collecting electrode is 30 mm in diameter. The more detailed structure is referred to a previous paper.⁵⁾ The membrane source was kept in contact with the entrance window by screwing the mount ring to the front frame of the extrapolation chamber. The absorbed dose rate of each source was several mGy·h⁻¹.

RESULTS AND DISCUSSION

When a source is calibrated by an extrapolation chamber in the geometric condition of surface-to-surface contact, good uniformity of activity distribution is required. Unless the activity distribution is sufficiently uniform, the resultant dose seriously depends on partial activity of the source facing to the small finite collecting electrode. This good uniformity is easily attained by using ion-exchange membrane sources. The standard deviation of activity distribution estimated by autoradiography was less than 4% for all ion-exchange membrane sources prepared with each radionuclide. Among them, the membrane sources with the deviation of 1 to 2% were selected especially for preparing the present calibration sources. In addition to the

uniformity, flatness of the membrane stretched on a mount ring and negligible removal of activity from the source enable the dose calibration by an extrapolation chamber.

The dependence of ionization currents on the electrode spacing was estimated for the membrane sources mounted on the rings with different diameters. The results for ^{90}Sr - ^{90}Y membrane sources are shown in Fig.2. The experimental points closely match a straight line for the 100 mm dia. source but do not for the 40 mm dia. source. Since a slope of the line determines the absorbed dose, the source diameter should be more than 50 mm at least for ^{90}Sr - ^{90}Y . The larger diameter is needed as the higher energy of β -rays because the tendency depends on the range of β -rays.

The membrane sources were cut into pieces 10mm in diameter for measurement of $4\pi\beta$ -emission rates. The emission rates were measured by $4\pi\beta$ -counting with a thin source backing (about 20 $\mu\text{g}/\text{cm}^2$ thick). The mean emission rate per unit area for each membrane source was derived from the average count rate for 5 pieces. For all tested sources with the same nuclide, the ratios of the dose determined by the extrapolation chamber to the mean emission rate show good agreement within the evaluated errors. On the basis of the emission rate measurement, the doses even for the sources with small size or any shape can be easily calibrated although it is impossible for them to be directly determined by an extrapolation chamber.

After calibrated by the extrapolation chamber, the membrane sources have to be stuck on a backing plate to obtain the proper supplement of backscattered β -rays. The influence of backscattered β -rays for the membrane sources of about 6 mg/cm^2 thick was estimated using a $2\pi\beta$ -counting system. The β -ray count rate for the ^{234}Tl membrane source increases by about 10% on a plastic backing and 20% on a stainless steel backing. However, the β -rays backscattered by a backing material can be absorbed by the membrane source itself. The influence is considered to remain slightly conservative if the layer of contamination source is too thin in comparison with the membrane source thickness. Therefore, it is much better to use as thin membrane sources as possible or to select the proper backing materials which compensate the loss of backscattered β -rays.

CONCLUSION

The ion-exchange membrane sources are suitable for preparing dose calibration sources in skin contamination by the following reasons.

The doses can be easily calibrated by the extrapolation chamber because of the uniformity of activity distribution, negligible removal of activity and flatness.

On the dose calibration by an extrapolation chamber, the membrane sources more than 50 mm in diameter need be used for ^{90}Sr - ^{90}Y . However, on the basis of the relation of the dose to the mean emission rate, the doses can be derived for the sources with any size and shape.

The influence of β -rays backscattered by skin tissue can be taken into account by selecting a proper backing material even

though the thickness of membrane source is not sufficiently thin in comparison with the layer of skin contamination source.

REFERENCES

1. Cross, W.G., Ing, H., Freedman, N.O. and Mainville, J., 1982, TABLES OF BETA DOSE DISTRIBUTIONS IN WATER, AIR AND OTHER MEDIA, AECL-7617.
2. Yoshida, M., Murakami, H., Ishizawa, M., Minami, K. and Yoshida, Y., 1988, A new calibration source using a thin ion-exchange membrane, Proc. Int. Radiat. Prot. Assoc. IRPA-7, 89.
3. Yoshida, M. and Martin, R.H., 1990, Preparation of Extended Sources with Homogeneous Polyethylene Ion-exchange Membrane, Appl. Radiat. Isot. Vol. 41, No. 4, 387.
4. International Organization for Standardization, 1984, Reference beta radiations for calibrating dosimeters and dose rate meters and for determining their response as a function of beta radiation energy, ISO6980-1984(E).
5. Murakami, H. and Ringo, K., 1987, Establishment of β -Ray Irradiation Field for Calibrating Radiation Protection Instrument, Hoken Butsuri, 22, 31.

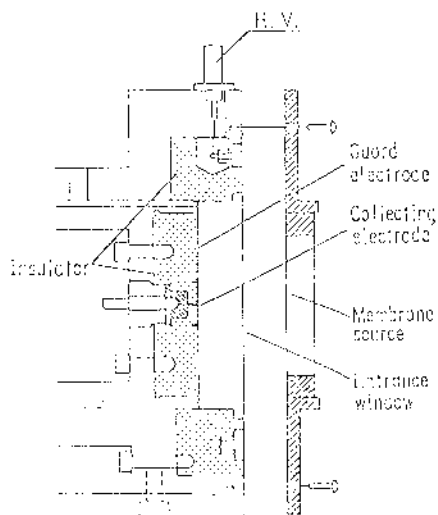

Fig.1 Cross-sectional view of extrapolation chamber and mounted membrane source

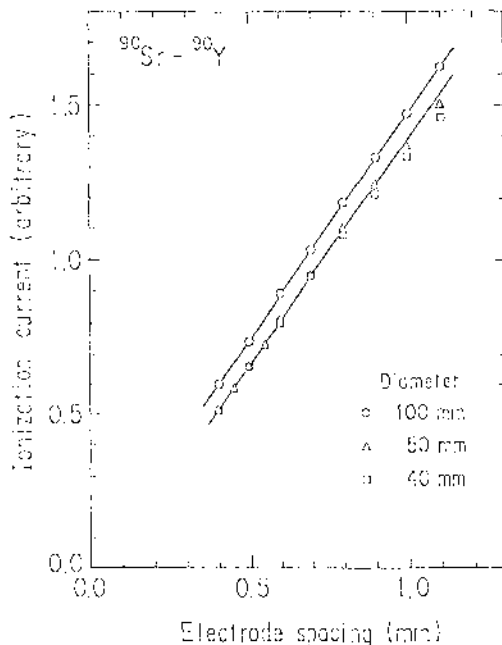

Fig.2 Ionization current as a function of electrode spacing of extrapolation chamber

INSTALLATION D'ETALONNAGE DES INSTRUMENTS DE MESURE DE LA
CONTAMINATION ATMOSPHERIQUE PAR AEROSOLS RADIOACTIFS
NATURELS OU ARTIFICIELS

J. Charuau, L. Grivaud, M. Le Breton
CEA/Institut de Protection et de Sûreté Nucléaire
Département de Protection de l'Environnement
et des Installations
CE/Saclay - 91191 GIF-SUR-YVETTE CEDEX, France

STANDARD TEST BENCH FOR CALIBRATING INSTRUMENTS USED
TO MEASURE NATURAL OR ARTIFICIAL RADIOACTIVE
AIRBORNE PARTICULATES

An aerodynamic calibration device, known as ICARE, has been set up in France at the Saclay Research Centre to certify instruments used to measure natural or artificial airborne radioactive particulate contamination or radon. ICARE can calibrate passive detectors and monitors with sampling air flow-rates of less than $60 \text{ m}^3/\text{h}$. The adjustment of such parameters as ^{222}Rn daughters volume activity, attached fraction and equilibrium factor, and the volume activity and size of α or β emitter carrying aerosols, allows realistic conditions to be obtained. ICARE complies with monitor test method standard currently under development by the International Electrotechnical Commission.

INTRODUCTION

L'installation ICARE /1/ répond au besoin de qualifier les instruments de mesure de la contamination atmosphérique dans des conditions réelles d'utilisation. Il est souhaitable de compléter les essais mécaniques, électriques et physiques (sources solides) par des essais dynamiques réalisés en présence d'aérosols radioactifs calibrés, émetteurs artificiels et/ou naturels.

Ainsi, les performances réelles des moniteurs de radioactivité artificielle pourront être connues (rendement de mesure, seuil de détection) en tenant compte des phénomènes liés à la granulométrie des aérosols : enfouissement dans les filtres, colmatage, autoabsorption α , rétention sur les parois, etc..., ainsi que de l'influence de la radioactivité naturelle (efficacité de la compensation radon). L'installation permet également d'étalonner les détecteurs de ^{222}Rn et/ou de ses descendants dans une large gamme d'activité volumique ; cette partie a été réalisée avec l'aide de la Commission des Communautés Européennes /2/.

DESCRIPTION ET PERFORMANCES

L'installation représentée par la figure ci-après, est constituée d'une veine gazeuse principale (0) dans laquelle circule un débit d'air filtré et régulé à $60 \text{ m}^3/\text{h}$; des aérosols radioactifs calibrés sont échantillonnés à des fins de contrôle, de mesure de référence et de prélèvement par les instruments à étalonner.

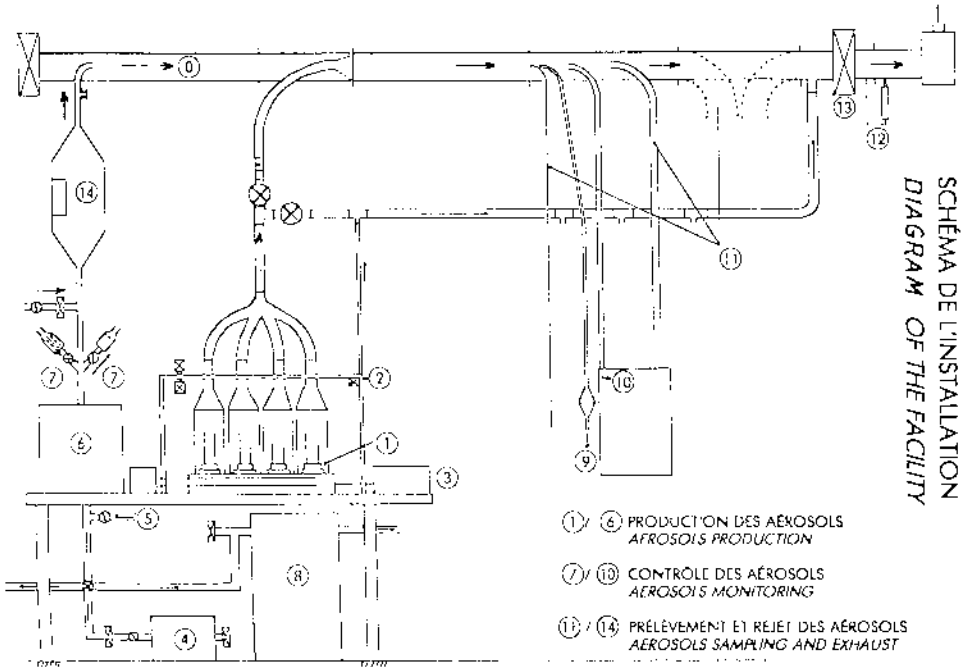

Radioactivité artificielle :

Des aérosols radioactifs artificiels, du type décrit dans /3/, sont produits par l'un des quatre pulvérisateurs liquides ultra-soniques (1) inclus dans une boîte à gants (2). Une solution aqueuse de CsCl contenant un traceur de ^{239}Pu ou de ^{137}Cs est pulvérisée en brouillard qui, entraîné par un débit d'air sec, crée un aérosol solide dont la taille est fonction de celle des gouttelettes de brouillard et de la concentration en sel. Un générateur de hautes fréquences (3) excite une céramique piézoélectrique qui émet des ondes ultra-sonores provoquant à la surface de la solution une fontaine au sommet de laquelle naît le brouillard dont la distribution granulométrique est peu dispersée. Le diamètre aérodynamique médian en activité des aérosols secs est $0,4 \mu\text{m}$ (aérosols fins) pour deux pulvérisateurs et $4 \mu\text{m}$ (gros aérosols) pour les deux autres. Ces deux valeurs encadrent bien la plage granulométrique des contaminations atmosphériques qui ont pu être mesurées dans l'environnement /4/ et dans des

installations nucléaires /5/. La mesure de référence de l'activité volumique, variable entre 8.10^{-2} et 12 Bq/m^3 pour ^{239}Pu et 10 à 10^5 Bq/m^3 pour ^{137}Cs , est obtenue à partir de prélèvements sur membrane filtrante des particules d'aérosol échantillonnées par une sonde isocinétique (9) ; le filtre est analysé par un Service de Métrologie habilité par le Bureau National de Métrologie. Des capteurs α et β (10) suivent en temps réel l'évolution de l'activité. Selon le débit de fonctionnement de l'instrument à étalonner, ce dernier est raccordé à l'une des sondes d'échantillonnage (11) prévues de 6.10^{-2} à $30 \text{ m}^3/\text{h}$; si le débit est celui de la veine gazeuse ($60 \text{ m}^3/\text{h}$), la veine est dérivée comme indiqué sur le schéma.

Radioactivité naturelle

Des aérosols radioactifs naturels issus des produits de filiation à vie courte du ^{222}Rn peuvent également être injectés dans la veine gazeuse principale, seuls ou en mélange avec les aérosols marqués artificiels, afin de mettre en situation réelle les instruments à étalonner. De plus, une chambre de test (14) permet d'étalonner les détecteurs de ^{222}Rn et/ou de ses descendants dans des conditions dynamiques, la vitesse de l'écoulement étant réglable jusqu'à $0,05 \text{ m/s}$.

Pour produire le radon, le système utilise un nouveau procédé breveté /6/ qui consiste en un dépôt solide de ^{226}Ra dans un feutre acrylique imprégné d'oxyde de manganèse ; le facteur d'émanation du radon dans l'air de balayage est voisin de 100%. Trois sources d'activité différentes permettent de faire varier l'activité volumique du radon dans la chambre de test de 4 à 4.000 Bq/m^3 . La mesure est faite en aval des sources par un conteneur normalisé utilisé pour les gaz radioactifs émetteurs de rayonnement γ . Selon un autre procédé breveté /7/, ce dispositif a été modifié par un arrangement du volume interne en des milliers d'alvéoles sur lesquelles se fixent les atomes des produits de filiation du radon. L'activité est mesurée par spectrométrie γ après le temps nécessaire à la mise à l'équilibre. Le dispositif a été préalablement étalonné avec un étalon gazeux multigamma $^{85}\text{Kr} + ^{127}\text{Xe}$.

Dans le volume de vieillissement (6) sont injectés le radon et des aérosols de CsCl produits par un nébuliseur pneumatique (5) dont la concentration est mesurée par un compteur de noyaux de condensation. Sa variation ainsi que celle du temps de séjour dans le volume permettent d'ajuster la valeur de la fraction attachée des descendants et de leur facteur d'équilibre. Le diamètre aérodynamique médian en activité : $0,2 \mu\text{m}$, est représentatif des valeurs moyennes mesurées dans les habitations. La détermination de l'activité volumique de chacun des descendants, de leur énergie α potentielle, de la

fraction attachée et du facteur d'équilibre est réalisée à partir des mesures de l'activité α de deux membranes filtrantes (7) ayant prélevé simultanément l'aérosol radioactif en aval du volume, la fraction libre ayant été piégée en amont de l'une des membranes. Ces informations sont données par un logiciel qui traite les signaux issus des ensembles de comptage par une méthode de déconvolution en fonction du temps ; la mesure est poursuivie jusqu'à ce que la précision donnée par le logiciel soit jugée satisfaisante.

CONCLUSIONS

L'installation d'étalonnage ICARE permet un réglage souple et reproductible des caractéristiques des aérosols radioactifs et du radon ; elles sont représentatives des conditions rencontrées dans l'environnement et dans les milieux industriels. Les mesures de référence sont reliées aux étalons nationaux, et les méthodes de test sont en voie d'être reconnues par la Commission Electrotechnique Internationale.

BIBLIOGRAPHIE

- /1/AMMERICH M., Réalisation d'une installation d'étalonnage de moniteurs de contamination atmosphérique à l'aide d'aérosols radioactifs calibrés (ICARE). Rapport CEA-R-5484, 1989
- /2/CEC Research. ICARE adapted to measure radon. Radon Research Notes. ORNL, October 1991, n° 6
- /3/CHARUAU J. Générateur d'aérosols calibrés "PLUS" (Pulvérisation Liquide UltraSonique) Radioprotection, GEDIM 1991, Vol. 26, n° 2, p. 405-409
- /4/GEORGI B. and TSCHERSCH J. Particle size distribution measurements of radionuclides from Chernobyl. Proceedings of the experts meeting at ISPRA, EUR 11755 EN, p. 99-111 (1987).
- /5/PERRIN M.L. Plutonium aerosols size distribution in a reprocessing plant and during decommissioning operations. Proceedings of the Department of Energy at Napa Valley, PNL A 14225, p. 79-86 (1985)
- /6/CHUITON G. Etude des caractéristiques physico-chimiques d'une source solide de radon 222. Rapport CEA-R-5532, 1990
- /7/CHARUAU J., GUELIN M., LE GAC J. Procédé et dispositif de mesure de la concentration des différents isotopes du radon. Brevet EN 8907109, 30 Mai 1989

DUAL TYPE NEUTRON MONITOR FOR BURST X-n MIXED FIELD

H. Obayashi, J. Kodaira, Y. Sakuma,
Y. Moriuchi¹, Sato² and T. Yamamoto³

National Institute for Fusion Science, Chikusaku, Nagoya,
464-01 Japan

¹Gifu College of Medical Technology, Seki, 501-32 Japan

²Aloka Co. Ltd., Oume, 198 Japan

³Institute of Scientific and Industrial Research,
Osaka University, Ibaraki, 567 Japan

ABSTRACT

A dual-type ionization chamber using ^3He and ^4He has been proposed and developed for monitoring X-n mixed fields in the vicinity of nuclear fusion experiments and other radiation sources. Some response characteristics of the system have been checked in different conditions.

INTRODUCTION

In large-scale plasma experiments for controlled nuclear fusion, energetic neutrons and X-rays will be produced, so that it should be important to monitor these radiations in and around the experimental zone. They are usually giving rise to a mixed field of burst pulse associating with the plasma shot. It is, therefore, quite desirable to develop a monitoring sensor effective for real-time measurements of neutron components and X-rays separately.

In view of safety control applications to the neighbouring area of the coming Large Helical Device (LHD) of NIFS, a dual-type neutron monitor has been designed and developed. As the type of sensors, ionization chamber scheme is adopted because of its simplicity and applicability to a wide range of radiation intensities.

IONIZATION CHAMBER

A dual-chamber system is consisting of two cells of the same geometric shape, volume and wall material. One of them is filled with pressurised ^3He gas, being sensitive to both neutrons and X-rays, and the other filled with ^4He gas being sensitive only to X-rays. The difference in signals from these cells is to give the neutron contribution.

Each chamber cell is a cylindrical vessel (80mm ϕ \times 200mm) of stainless steel (3mm thick) to give a gas volume of 1

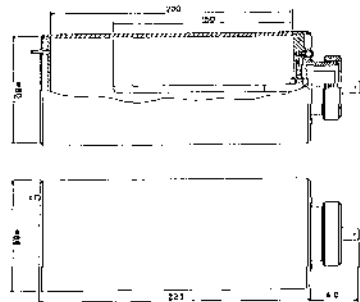

Fig. 1. Chamber cells.

litre. A rod-type electrode (5mm ϕ \times 150mm) is held coaxially inside the cell with an insulated gaurd ring structure installed at one end of the cylinder. (Fig.1) An electric potential is supplied to the cell wall, keeping the gaurd ring to the ground potential. The charge collected on the electrode is introduced to a capacitance vibrating electrometer to observe the current output. Measurable current range is $10^{-5} \sim 10^{-11}$ A with a moderate time constant. In the testing experiments, each cell of the chamber pair is connected with its own electrometer to avoid unexpected interference.

Chamber cells with ^3He and ^4He gases of different pressures (1~6 atm) are prepared, as well as the one with 1-atm air for comparison. If the neutron signals from ^3He are due to a thermal capture process ($n + ^3\text{He} \rightarrow t + p + 765 \text{ keV}$), the stopping range of the secondary p and t in 1-atm ^3He gas are estimated as 4.5 cm and 2.2 cm, respectively. Since we are interested in neutron energies up to a few MeV, a detachable polyethylene moderator (5 cm thick) is usually placed surrounding the chamber cells. The whole system is situated in a casing of 1 mm thick Cu plate to shield electromagnetic noise.

RESPONSES TO GAMMA-RAYS

As the first step of testing the chamber characteristics irradiation against ^{60}Co gamma rays has been carried out. A test field is available at the Co-60 Radiation Room, belonging to Dept. Synthetic Chemistry, Nagoya University, where a strong ^{60}Co source of $\sim 10^7$ TBq is installed.

When the applied potential is varied, the current output to the electrometer reveals itself as a saturation curve. In Fig.2 typical examples are shown, for 1-atm cells of air, ^3He , and ^4He , respectively, with outward positive potentials. The responses of ^3He and ^4He are quite similar to each other, while the air chamber gives much higher saturation current levels and potentials.

The saturation curves are dependent on the polarity of applied voltage, as well as on the gas species and pressures. The current increases in the outer positive potential case are slower than the negative case, and seems to reach somewhat lower levels in saturation. These features may reflect the

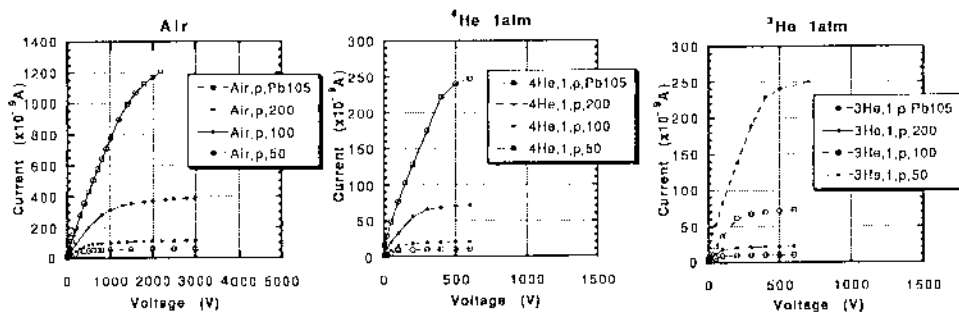

Fig. 2. Saturation curves.

possible space charge effects around the axial electrode as well as the recombinations efficient in the ion collection processes, and further detailed analysis is needed.²

In order to see the response-to-dose characteristics of these chambers for gamma rays, we have compared data of different field intensities. In the Co-60 Radiation Room, where high absorbed dose rates of $10 \sim 10^3$ Gy/h are attained and the typical response currents from 1-atm ^4He are ranging $10^{-7} \sim 10^{-6}$ A. In addition to the experiments in such a strong field, we have made another exposure test by use of many orders of magnitude weaker ^{60}Co (~ 10 MBq) in an open space. This gives absorbed dose rates $10^{-5} \sim 10^{-3}$ Gy/h, and the observed outputs are down in $10^{-14} \sim 10^{-12}$ A, which are almost the lowest detectable limit of the present system. The proportionality covering these two limits is well justified. (Fig.3)

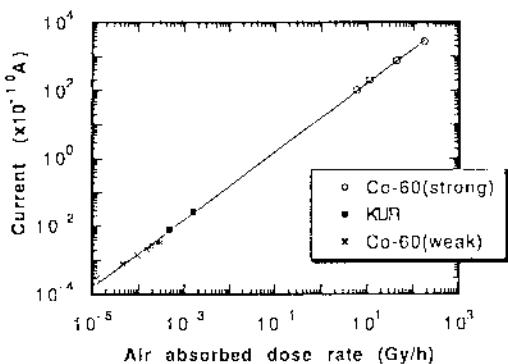

Fig. 3. 1-atm ^4He responses to gamma rays.

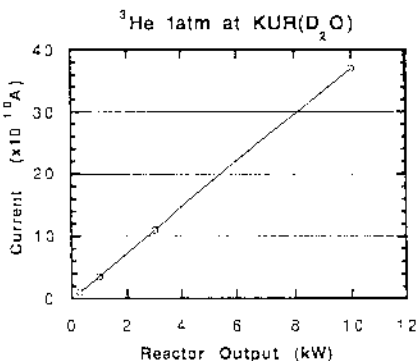
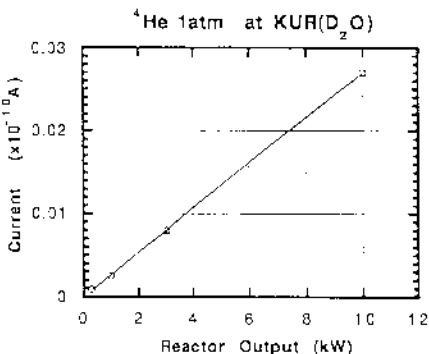

Fig. 4. Responses of ^3He and ^4He to KUR thermal neutrons.



RESPONSES TO THERMAL NEUTRONS

The neutron responses of ^3He chamber has been surveyed by means of D_2O -thermalised neutron irradiation at the KUR fission reactor of Research Reactor Institute, Kyoto University.

In Fig.4 are shown the results. Responses from ^3He and ^4He are plotted against the operated reactor powers. Both response currents give very good linearity, though the current ratio $^3\text{He}/^4\text{He}$ is as high as $\sim 10^3$. This implies that the small amount of gamma rays coexisting in the thermal neutron area can easily be separated with the dual-chamber. In reactor

operations at 3 kW and 10 kW, the air-absorbed gamma doses were known. The ^4He responses in these cases are plotted in Fig.4 together with ^{60}Co data, showing very good fitting to the line. The thermal neutron flux in the area is estimated by a different experiment³ as $9.6 \times 10^8 \text{ n cm}^{-2} \text{ s}^{-1}$ at 1 kW operation, so that the observed ^3He current $0.35 \times 10^{-9} \text{ A}$ should imply the thermal neutron sensitivity of the 1-atm ^3He chamber with moderator to be $3.6 \times 10^{-17} \text{ A/n cm}^{-2} \text{ s}^{-1}$.

TESTINGS WITH MIXED X- γ FIELD

A preliminary operation test of the dual-chamber system in ^{252}Cf has been done. An available source is estimated to contain some $0.067 \mu\text{g}$ of ^{252}Cf isotope, and a neutron emission rate of $1.55 \times 10^6 \text{ n/s}$ and a gamma exposure rate of $9.5 \times 10^{-4} \text{ Gy/h}$ at 1 m are expected. Using 1-atm ^3He and ^4He chambers, response to source distance characteristics have been examined. The ^3He responses reveal $r^{-1.5}$ decrease with distance r , and some 40 times higher than the ^4He ones, though the latter signals are very low and scattered in $10^{-10} \sim 10^{-11} \text{ A}$ regime. It would be desirable to make use of a stronger source to obtain a more definite results.

SUMMARY AND REMARKS

A dual-type cylindrical ionization chamber system has been developed for the dosimetry use of the neutrons and X(gamma)-rays. Several tests so far carried out in various field conditions seem to show good capability of the system.

Tasks and issues left for the future:

- (i) Tests in the burst-like pulse fields (use of existing accelerators or plasma devices)
- (ii) The method of practical data treatment, including the built-in data processing scheme (such as automatic ^3He - ^4He subtractions) and conversions to dose-equivalent quantities.
- (iii) The detailed considerations on the chamber characteristics, physical and/or simulational analyses to understand the general behaviours as well as better choice of materials and structures.

ACKNOWLEDGEMENTS

The authors thank Prof. T.Miyazaki (Nagoya University), and Prof. T.Tsujimoto and Dr. T.Yoshimoto (Kyoto University) for their kind arrangements in making the irradiation tests. Useful discussions and works are due to H.Yamanishi.

REFERENCES

1. J.Kodaira, et al., Proc. 8th Symp. Acc. Sci. & Tech., 1991, Tokyo. (Ionics, 1991)
2. J.W.Boag, in The Dosimetry of Ionizing Radiation, Vol. II (1987) 169 (Academic Press, Inc.)
3. M. Mito, private communication

CALIBRATION OF PARALLEL PLATE IONIZATION CHAMBERS IN DIFFERENT KINDS OF RADIATION

Linda V.E. Caldas and Maria P.P. Albuquerque

Instituto de Pesquisas Energéticas e Nucleares
Comissão Nacional de Energia Nuclear
São Paulo, Brazil

ABSTRACT

Parallel plate ionization chambers designed and constructed for use in low energy X-radiation fields were tested in beta ($^{90}\text{Sr} + ^{90}\text{Y}$), gamma (^{60}Co and ^{137}Cs) and intermediate energy X-radiation, in order to verify the possibility of their usefulness for the detection of these kinds of radiation. The obtained calibration factors were compared with those of the secondary standards of each type of radiation.

INTRODUCTION

Different types of ionization chambers are normally used depending on the kind of radiation. The parallel plate ionization chambers are recommended for low energy X-radiation dosimetry^{1,2}. However some interest has been already shown in the use of such chambers in other kinds of radiations^{3,4}. The objective of this work was to verify how to use these chambers in beta, gamma and intermediate energy X-radiation, in order to avoid the necessity of acquisition of several chambers.

EXPERIMENTAL MEASUREMENTS

Two parallel plate ionization chambers A and B, of circular form, with Lucite bodies, active volumes of 0.6 cm^3 , graphite collecting electrodes and guard-rings, designed and manufactured at IPEN^{5,6}, were tested at three different laboratories. Chamber A was examined in Brazil, using the irradiation systems of the calibration laboratories of São Paulo (IPEN) and Rio de Janeiro (Instituto de Radioproteção e Dosimetria - IRD), and chamber B was calibrated at the Secondary Standard Dosimetry Laboratory of Neuherberg, GSF, Germany (Institut für Strahlenschutz). In each case the chamber response was compared with that of a corresponding secondary standard chamber. The standard deviation of all these measurements was lower than 0.20%.

For low energy X-radiation the obtained calibration factors for the chamber A can be seen in Table 1 in comparison to those of the secondary standard ionization chamber (P) for this

energy range. Both chambers A and P are of the superficial type. The energy dependence of chamber P presents a variation of 1.9%, while it is only 0.3% for chamber A.

In the case of intermediate energy X-radiation, the calibration factors for the chamber A are presented in Table 2. Chamber T is the secondary standard chamber (thimble type) recommended for this kind of radiation. It can be seen that chambers A and T show variations of 5.7 and 2.1% respectively for the energy dependence in the considered range.

In order to test the chamber A in gamma radiation fields, at the laboratory of São Paulo, a ^{60}Co Kelcoet Barnes Flexaray and a ^{137}Cs Cosapan-M, Generaly, were used. At the German laboratory GSF a Gammatron and a Theratron were employed with the chamber B. Initially the electronic equilibrium thickness had to be determined, taking measurements for different Lucite absorbers: 3.3 mm (^{60}Co) and 1.2 mm (^{137}Cs). The obtained results are shown in Table 3, normalized to ^{60}Co response (because different electronic equipments were used), in comparison to commercial chambers (superficial and thimble). All chambers were calibrated against the normally utilized secondary standard for gamma radiation. The greatest energy dependence was presented by the chamber C (1,2%); chambers A and B show similar behaviours to that of chamber D, which is of the recommended type (thimble) for gamma radiation.

In the case of beta radiation the $^{90}\text{Sr} + ^{90}\text{Y}$ sources of the secondary standards of the calibration laboratories of IPEN and GSF were utilized. The reference instrument for this kind of radiation is the extrapolation chamber (E). In Table 4 the calibration factors are presented.

CONCLUSION

The obtained results show the usefulness of the parallel plate ionization chambers developed at IPEN for X, gamma and beta radiation detection.

REFERENCES

1. IAEA, 1987, International Atomic Energy Agency. Absorbed Dose Determination in Photon and Electron Beams. An International Code of Practice, Vienna, Technical Report Series 277.
2. IAEA, 1979, International Atomic Energy Agency. Calibration of Dosimeters used in Radiotherapy, Vienna, Technical Report Series 185.
3. Keys, D.J. and Purdy, J.A., 1980, Thin-walled Parallel Plate Ionization Chamber for Use with Photon and Electron Beam Dosimetry, Med. Phys. 7 (2) 163-164.

4. Kooy, H.M., Simpson, L.D. and McFaul, J.A., 1988, Parallel Plate Ionization Chamber Response in Cobalt-60 Irradiated Transition Zones, Med. Phys. 15 (2) 199-203.
5. Albuquerque, M.P.P. and Caldas, L.V.E., 1989, New Ionization Chambers for Beta and X-Radiation, Nucl. Instrum. Meth. Phys. Res., A 280, 310-313.
6. Caldas, L.V.E., 1991, A Sequential Tandem System of Ionization Chambers for Effective Energy Determination of X-Radiation Fields, Radiat. Prot. Dosim. 36 (1) 47-50.

TABLE 1

Calibration factors of chambers A and P (secondary standard NPL model 2536/3B, superficial type) for low energy X-rays. Calibration Laboratory, IPEN, São Paulo X-ray system: Geigerflex, Rigaku Denki su: scale unit

Half-Value Layer (mmAl)	Calibration Factor $R \cdot su^{-1} (10^{-4} C \cdot kg^{-1} \cdot su^{-1})$	
	Chamber A	Chamber P
0.37	1.061 (2.74)	0.919 (2.37)
0.56	1.063 (2.74)	0.911 (2.37)
0.65	1.063 (2.74)	0.908 (2.37)
0.91	1.064 (2.75)	0.902 (2.33)

TABLE 2

Calibration factors of chambers A and T (secondary standard
 ÖES, model TK01, thimble type) for intermediate energy X-rays.
 Calibration Laboratory, IRD, Rio de Janeiro
 X-ray system: Stabilipan 300, Siemens
 su: scale unit

Half-Value Layer (mmAl)	Calibration Factor R.su ⁻¹ (10 ⁻⁴ C.kg ⁻¹ .su ⁻¹)	
	Chamber A	Chamber T
0.06	1.023 (2.64)	0.877 (2.26)
0.16	0.996 (2.57)	0.866 (2.23)
0.53	0.970 (2.50)	0.864 (2.23)
1.00	0.968 (2.50)	0.862 (2.22)
2.02	0.988 (2.55)	0.859 (2.22)

TABLE 3

Energy dependence of chambers A, B, C (NE model 2532/3, superficial
 type) and D (NE 2505/3, thimble type) for gamma radiation

Source	Chamber			
	A	B	C	D
⁶⁰ Co	1	1	1	1
¹³⁷ Cs	1	0.995	0.988	1.005

TABLE 4

Calibration factors of chambers A, B, P and E (extrapolation
 chamber PTW model 23391) for beta radiation of ⁹⁰Sr + ⁹⁰Y

Chamber	A	B	P	E
Calibration Factor cGy.su ⁻¹	0.835	0.728	0.663	0.748

The New Personnel Neutron Dosimetry System at the

PAUL SCHERRER INSTITUTE

C. Wernli, K. Langen

PAUL SCHERRER INTSTITUTE

Radiation Metrology Section

5232 VILLIGEN / PSI Switzerland

FAX: 056/98 23 27 PSI CH

INTRODUCTION

The characteristics of CR-39 detectors have been investigated intensively during the last years in many laboratories. The enlargement of tracks by electrochemical etching made counting easier but, on the other hand, complicated the etching process. For routine application of CR-39 in neutron personal dosimetry neither etching nor reading should be complicated or time consuming.

Recently NE-Technology (formerly: Vinten) introduced an automatic reader for chemically etched CR-39 detectors. Along with this reader a new CR-39 Material, PN3, was made available. This system would allow for a routine application of CR-39.

The characteristics of PN3 detectors and possible batch constructions were investigated.

EXPERIMENTAL CONDITIONS

Detector material

The CR-39 material which we used was PN3 from NE-Technology, England. The detectors were 1,5 mm thick and 20 mm x 25 mm in size. All detectors were cut and coded by the supplier.

Etching conditions

The detectors were chemically etched using a two-step technic. This etching procedure is the standard procedure recommended by the manufacture [1]. During the first step, the pre-etch step, the detectors were immersed in a 60% methanol and 40% 6.25 N NaOH solution at 70°C for one hour. Under these conditions the bulk etching velocity is equal to the track etch velocity and therefore the surface of the detector is polished without etching the tracks in this surface layer [1]. About 30 µm of each detector surface is removed by this step.

During the second step the detectors are immersed in 6.25 N NaOH solution at 70°C for six hours.

Counting system

Since the automatic reader of NE Technology was available as a prototype instrument only, most detectors were counted with the Quantimet 920 in connection with an optical microscope under the magnification of 32x. For each detector 200 fields of view with the field size of $250 \mu\text{m} \times 250 \mu\text{m}$ each were analysed. The total analysed area was $1/8 \text{ cm}^2$. Tracks with a diameter smaller than $2,7 \mu\text{m}$ were discriminated.

ENERGY RESPONSE

Response to thermal neutrons

For thermal neutron irradiation a polyethylen moderated Am-Be source was used. For the detection of thermal neutrons the $\text{Li-6}(n,\alpha)\text{H-3}$ reaction was applied. The resulting α -particles have an energy of 2,04 MeV which corresponds to a range of about $10 \mu\text{m}$ in CR-39 [2]. Because of this short range, the α -particles do not penetrate the pre-etch layer and are therefore not detectable. The tritium particles of the same reaction have an energy of 2,74 MeV what results in a range of about $60 \mu\text{m}$ in CR-39 [3]. Therefore the H-3 particles are detectable.

For the irradiation with thermal neutrons we placed TLD-700 (LiF) on the detector surface. The response was found to be about 100 times as high as for bare Cf.

Response to Cf-252 and Am-Be neutron fields

Since over a wide range of neutron energies the elastic scattering on protons is the dominating reaction for the production of detectable particles, a radiator with a high hydrogen content is used to increase the response of the detector. As mentioned above, a $30 \mu\text{m}$ layer is removed during the pre-etch step. Since this thickness corresponds to the range of about 1,2 MeV protons [2], this pre-etch layer serves as an effective radiator for neutrons with energies below about 1,2 MeV. If the neutron energy exceeds this value the response can be increased by an external radiator.

To test this effect, the detector was divided in two different fields. One field was covered by 3 mm of polyethylen. The second had to be covered by a material with a low overall cross section for neutrons. For this purpose aluminium was chosen. Figure 1 shows the radiator stack that was applied during the irradiations. This stack was irradiated with bare Cf and Am-Be neutrons. The frontside of the detector, this is the side that is analysed later by track counting, faced the source. The stack was mounted on a 15 cm thick 30 cm x 30 cm plexiglass slab phantom. Table 1 shows the results of this experiment.

The ratio of the responses of the aluminium covered detector field to the polyethylen covered detector field for the Am-Be irradiation is lower compared to the Cf

irradiation. This shows that this ratio can serve as a rough figure for spectrometric information. If the main dose contribution derives from neutrons with energies up to 1,2 MeV this ratio should be close to 1. If the percentage of higher energy neutrons increases, the ratio decreases.

Table 1: Response for Various Neutron Energies

Neutron field	Radiator	Response \pm SD [Tracks * cm ² * mSv ⁻¹]
Thermal	Li-6 (TLD-100)	31500 \pm 7040
Bare Cf	3 mm polyethylen	250 \pm 61
Bare Cf	2 mm Al	164 \pm 46
Am-Be	3 mm polyethylen	295 \pm 57
Am-Be	2 mm Al	117 \pm 32
50 MeV	air	165 \pm 20
50 MeV	3 cm plexiglass	179 \pm 45
70 MeV	air	160 \pm 23
70 MeV	3 cm plexiglass	167 \pm 25

In order to look at the effect of the wearing direction of the dosimeter, we turned the radiator stack by 180° towards the phantom. Now the front side of the detector faced the phantom. As expected, both fields showed a similar response, since in this case the 1,5 mm thick detector serves as a radiator. The overall response (210 \pm 31 tracks * cm⁻² * mSv⁻¹) decreased because the relative hydrogen content of CR-39 (48.6 %) is lower than that for polyethylen (66.6 %).

In order to be able to receive some spectrometric information from the comparison of the two fields, the dosimeter should be worn in the proper direction.

Response to 50 MeV and 70 MeV Neutrons

Different CR-39 materials, including PN3 were irradiated with 50 MeV and 70 MeV neutrons at the Paul Scherrer Institute. For a more detailed description of the experiment and the results see ref. [4]. For the irradiation one detector was placed in front of a 3 cm plexiglass slab and a stack of 5 detectors was fixed behind the slab. The results show that the plexiglass had practically no influence on the response of the detectors. The results are also shown in Table 1. In general the sensitivity is about 2/3 of that for bare Cf.

Fig. 1: Detector stack

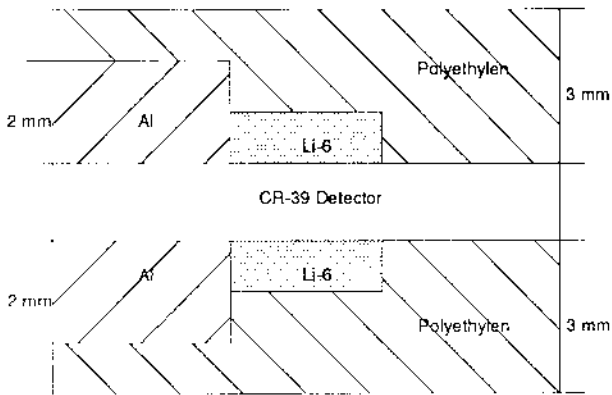

APPLICATION IN ROUTINE DOSIMETRY

For routine application a first reading could be restricted to the fields covered by polyethylen and Li-6. The reading of the field behind aluminium is thought to be applied for detectors only which show a dose above a certain investigation level. The feasibility of the system is being investigated in an extended field test in accelerator and reactor environments.

REFERENCES

- [1] Harvey, J.R., Weeks, A.R. Progress Towards the Development of a Personal Neutron Dosimetry System Based on the Chemical Etch of CR-39. UK CEEB Report, TPRD/B/0851/R 86, (1986)
- [2] Jäger, R.G., Hübner, W. Dosimetrie und Strahlenschutz. 2. Auflage. Georg Thieme Verlag, Stuttgart (1974)
- [3] Rich, M., Madey, R. Range Energy Tables. UCRL-2301, (1954)
- [4] Azimi, D., Langen, K., Wernli, C. The Response of Various Neutron Dosimeters at high Energy Neutrons. (To be published), 1992

DEVELOPMENT OF REAL TIME PERSONAL NEUTRON DOSIMETER WITH TWO SILICON DETECTORS

T. Nakamura, N. Tsujimura
Cyclotron and Radioisotope Center, Tohoku University
Aoba, Aramaki, Aoba-ku, Sendai 980, Japan

T. Yamano
Tokyo Factory, Fuji Electric Co. Ltd.
Fuji-cho 1, Hino, Tokyo 191, Japan

ABSTRACT

We developed a real time personal neutron dosimeter by using two types of silicon p-n junction detectors, thermal neutron sensor and fast neutron sensor. The thermal neutron sensor which is ^{10}B doped n-type silicon with a polyethylene radiator mainly counts neutrons of energy from thermal to 1 MeV, and the fast neutron sensor which is p-type silicon with a polyethylene radiator is sensitive to neutrons above 1 MeV. The neutron sensitivity measurements revealed that the dosimeter has a rather flat response for dose equivalent from thermal to 15 MeV, excluding a drop from 50 keV to 1 MeV. In order to get the conversion factor from counts to dose equivalent as accurately as possible, we performed the field test of the dosimeter calibration in several neutron-generating fields. By introducing the two-group dose estimation method, this dosimeter can give the neutron dose equivalent within about 50% errors.

I. INTRODUCTION

The development of personal neutron dosimeters that indicate the dose equivalent in real time becomes important with the increased number of people working in high intensity, high energy accelerator facilities and nuclear fuel reprocessing plants. To produce an instrument that is small and light, and has enough sensitivity to neutrons is a difficult task.

Recently, two types of direct-reading personal neutron dosimeters have newly been developed. One is a bubble-damage polymer detector which uses tiny, superheated droplets of a detector liquid uniformly dispersed in a firm elastic polymer developed separately by Ing et al.¹ and Apfel et al.² The other is a silicon dosimeter developed by Nakamura et al.³ which uses two types of silicon p-n junction detectors fabricated by Fuji Electric Co. Ltd. This dosimeter had low neutron sensitivity and we further realized the dosimeter of higher sensitivity by using larger silicon detector of 1 cm x 1 cm. One type, thermal neutron sensor, is an n-

type silicon crystal on which a p' layer of elementary boron enriched 94% ^{10}B is deposited in about 1 mm thickness and the other type, fast neutron sensor, is an p-type silicon crystal without boron coating. Both crystals are contacted with 0.08 mm thick polyethylene radiators and in some cases only the thermal neutron sensor is covered with a polyethylene moderator of 10 mm thickness. Figure 1 shows a schematic cross sectional view of the dosimeter.

II. NEUTRON SENSITIVITY MEASUREMENT

A. Experimental

The neutron detection efficiencies of these two sensors were measured in the monoenergetic fast neutron field at the Fast Neutron Laboratory of Tohoku University. Monoenergetic neutrons of five discrete energies of 200 keV and 550 keV by the Li(p,n) reaction, 1 MeV by the T(p,n) reaction, 5 MeV by the D(d,n) reaction and 15 MeV by the T(d,n) reaction were produced using

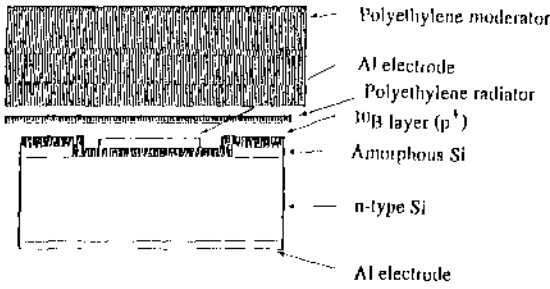

Thermal neutron sensor

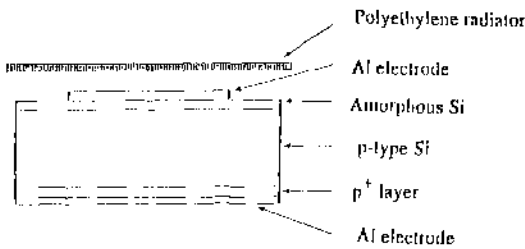

Fast neutron sensor

Fig. 1 Schematic cross sectional view of two silicon sensors

the Dynamitron accelerator. The dosimeter was placed in the forward direction to the beam axis. The neutron fluence incident on the dosimeter was measured with a ^{235}U fission chamber placed in front of the dosimeter. Since the ^{235}U fission chamber is sensitive to low energy neutrons scattered from the surrounding objects, a hydrogen proportional counter which was adjusted to count neutrons above several tens of keV was also placed at about 45 deg to the beam axis as a subsidiary neutron fluence monitor. The efficiency measurement of the thermal neutron sensor to thermal neutrons was done in the experimental hole of the TRIGA-II type reactor of Rikkyo University and in the thermal neutron field leaked from a graphite pile of Institute of Radiation Measurements. Thermal neutron fluence incident on the dosimeter was measured with a gold activation foil. The dosimeter encapsulated two silicon sensors was placed in front of a commercially available ellipsoidal water phantom, 45 cm high and 30 cm wide. The output pulses due to alpha particles produced by the $^{10}\text{B}(n,\alpha)$ reaction and protons recoiled from the elastic collision in the polyethylene radiator were measured with a multichannel analyser.

B. Results

Figure 2 shows the neutron detection efficiency of the dosimeter as a function of neutron energy. The measured results are the sum of the integrated counts given by the thermal neutron sensor and the integrated counts of the fast neutron sensor multiplied by a factor of 40, in order to get the detection efficiency as close as possible to the fluence-to-dose-equivalent conversion factor given by ICRP-51 which is drawn in a dotted line. In Fig. 2, the results calculated with the MORSE-CG code are also shown to compare with the results measured by the thermal sensor. Since the recoil proton pulses from the radiator were not included in the MORSE calculation, this comparison is valid only in the energy range below 1 MeV, where it shows good agreement between experiment and calculation.

This dosimeter which combines two silicon sensors has neutron sensitivity over a wide energy range from thermal to 15 MeV and also has good energy response, excluding a large deviation from the ICRP-51 response curve in the energy range from 50 keV to 1 MeV, as seen in Fig. 2.

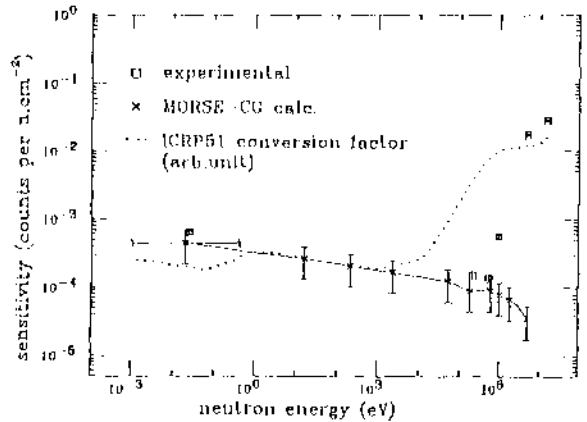

Fig. 2 Comparison of measured and calculated neutron detection efficiencies of the dosimeter, together with the ICRP-51 fluence-to-dose-equivalent conversion factor

III. FIELD TEST OF DOSIMETER RESPONSE

Because of the deviation of the dosimeter energy response from ICRP-51, it is necessary to determine the conversion factor from counts to dose equivalent values to be fitted in various spectral fields necessary for neutron monitoring. For getting this conversion factor, we have been doing the field test of the dosimeter calibration in the following typical neutron fields having known neutron energy spectra; 1) moderated ^{252}Cf neutron source calibration field, 2) a beam extraction hole of the fast neutron source reactor of University of Tokyo, 3) labyrinth from the 40 MeV cyclotron room of Tohoku University, 4) MOX (Mixed Oxide) fuel handling room of Power Reactor and Nuclear Fuel Development Corporation and so on.

In these field tests, the dosimeter was fixed on the water phantom faced to the neutron beam direction. The measured counts were compared with the dose equivalent values obtained from the dose equivalent counters (rem counters) of Studsvik 2202D and Fuji Electric NSN1 which were used as neutron dose monitors. Considering the energy response of the dosimeter shown in Fig. 2, we propose the following two-group dose estimation method which divides neutrons into two energy groups of thermal to 1 MeV and above 1 MeV. The total neutron dose equivalent H is given by adding the neutron dose equivalent of energy higher than 1 MeV, H_1 and that of energy lower than 1 MeV, H_2 . H_1 and H_2 are given by

$$H_1 = K_1 C_1 \quad \text{for } E_n \geq 1 \text{ MeV,}$$

$$H_2 = K_2 (C_2 - R C_1) \quad \text{for } E_n \leq 1 \text{ MeV,}$$

where C_1 , C_2 are the respective counts measured with fast sensor and thermal sensor, K_1 , K_2 are the respective conversion factor in units of $\mu\text{Sv}/\text{count}$,

R is the correction factor which subtracts the contribution of fast neutrons above 1 MeV counted in thermal sensor. From the results of these field tests, the K_1 and R values were found to be fixed as 2.0 and 0.5, while on the other hand, K_2 had to be three different values corresponding to the neutron energy spectra.

Table 1 summarizes typical examples. The K_2 value becomes smaller with decreasing the mean neutron energy in the test neutron fields. Figures 3 to 5 show the neutron energy spectra in lethargy units. The K_2 value of 2.0 in Table 1 corresponds to the field close to fission neutron spectrum which is appeared in bare ^{252}Cf neutron source field in Fig. 3⁴ and in PuO_2 - UO_2 mixed fuel field in Fig. 4.⁵ The K_2 value of 0.075 corresponds to the field close to 1/E slowing-down neutron spectra which is seen in polyethylene-moderated ^{252}Cf neutron source field in Fig. 3 and at the point 2 in the entrance of the labyrinth connected to the accelerator room in Fig. 5,⁶ and that of 0.015 to the well-thermalized neutron field at the point 7 near the exit of labyrinth in Fig. 5. Table 1 also gives the ratio of dose equivalent values given by this dosimeter and those by the rem counters. By using the conversion factors of K_1 , K_2 and R shown in Table 1, it was revealed that this dosimeter can give the neutron dose equivalent within about 50% difference at maximum.

IV. CONCLUSION

The characteristics of our newly-developed real-time personal neutron dosimeter based on the present study can be summarized as follows; (1) From these field experiments, this dosimeter will be possible to give the neutron dose equivalent within about 50% errors in the energy range from thermal to 15 MeV.

Table 1 Summary of field test of dosimeter calibration

Field	Mean Neutron Energy (MeV)	K_1 ($\mu\text{Sv}/\text{count}$)	K_2 ($\mu\text{Sv}/\text{count}$)	Ratio ¹
^{252}Cf (bare)	2.11	2.0	2.0	1.11
PuO_2 - UO_2	1.8	2.0	2.0	1.09
^{252}Cf (polyethylene)	1.0	2.0	0.075	1.40
Labyrinth No. 2	0.026	2.0	0.075	0.71
Labyrinth No. 7	0.012	2.0	0.015	1.32

¹ Ratio of dose equivalent values given by this dosimeter to those by rem counter

(2) The dosimeter is insensitive to gamma rays up to about 100 mSv/h.

(3) The size and weight of the dosimeter is about 100 mm x 60 mm x 20 mm and about 150 g, respectively, which is small and light enough for personal dosimeter.

REFERENCES

1. H. ING and H. C. BIRNBOIM, "Bubble-Damage Polymer Detectors for Neutron Dosimetry", 5th Symposium on Neutron Dosimetry, Neuherberg, Germany, Sept. 17-21, 1984.

2. R. E. APFEL, Nucl. Instrum. Methods, 162, 603 (1979); R. E. APFEL and S. C. Roy, Radiat. Prot. Dosim., 10, 327 (1985).

3. T. NAKAMURA, M. HORIGUCHI, T. SUZUKI and T. YAMANO, Radiat. Protec. Dosim., 27, 149 (1989).

4. S. IWAI, T. OHKUBO, A. HARA and T. NAKAMURA, Nucl. Instrum. Methods, A254, 159 (1987).

5. unpublished

6. T. ISHIKAWA, M. KUMAZAKI and T. NAKAMURA, in press of J. Nucl. Sci. Technol.

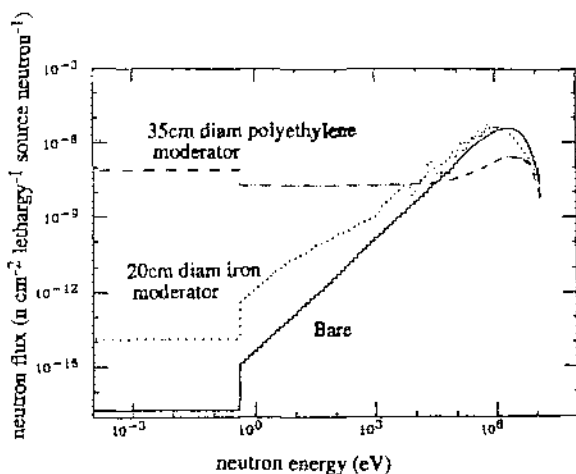

Fig. 3 Neutron energy spectra of bare, iron-moderated and polyethylene-moderated ^{252}Cf neutron source fields [4].

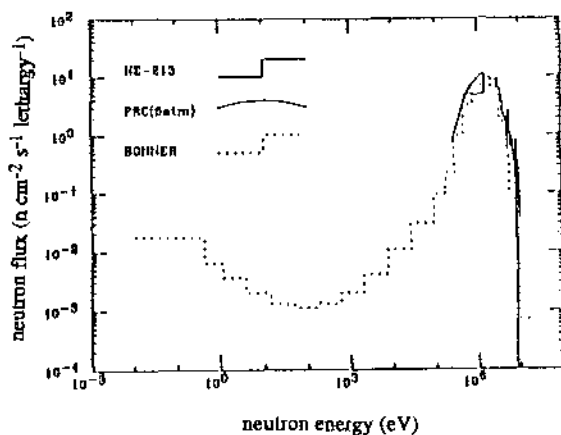

Fig. 4 Neutron energy spectrum of $\text{PuO}_2\text{-UO}_2$ mixed oxide nuclear fuel field [5].

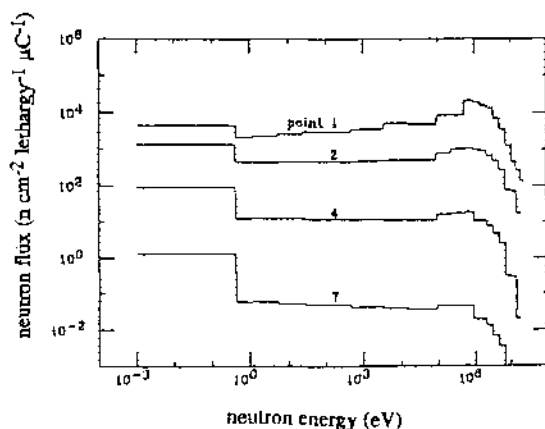

Fig. 5 Neutron energy spectra at several points in the labyrinth connected to the 40 MeV cyclotron room [6].

DETERMINATION OF AMBIENT DOSE EQUIVALENT IN MIXED RADIATION FIELDS BY MEANS OF RECOMBINATION CHAMBER

Institute of Atomic Energy, Swierk, Poland
(Work partly supported by International Atomic Energy Agency under Research Contract 6353/RB)

N. Golnik and M. Zielczynski

ABSTRACT

The response of the REM2 recombination chamber to $H^*(10)$ was determined for some photon and neutron radiation fields (X-rays with effective energy 111 keV, gamma radiation of ^{137}Cs and ^{60}Co sources, the radiation of isotopic neutron sources $^{241}\text{Am-Be}$ and ^{252}Cf , monoenergetic neutrons in energy range from thermal to 19 MeV). For mixed gamma-neutron radiation with broad neutron energy spectrum the response of the chamber to $H^*(10)$ is constant within 20%, so the chamber can be used as a good detector for monitoring of the ambient dose equivalent.

INTRODUCTION

The recombination chamber it is a high-pressure ionization chamber operated in non-saturated mode. In this mode the initial recombination of ions is significant, so the sensitivity of the chamber depends on LET of incident radiation and provides information about the quality of this radiation. Therefore the chamber can be used for determination of the dose equivalent.

Recently, the ambient dose equivalent $H^*(10)$ is recommended as an operational radiation protection quantity for external radiation. The aim of this work was to estimate, whether the recombination chamber can be used for determination of this quantity in mixed neutron - gamma fields.

INSTRUMENT

For present investigation the REM2 recombination chamber was chosen. The chamber was manufactured in Poland by POLON. Now it is no longer commercially available, but it is still routinely used in some laboratories over the world for monitoring of the dose equivalent. REM2 is a parallel-plate ionization chamber with 25 tissue-equivalent plates, the volume of 2 dm³, the mass of 6 kg and the effective wall thickness of about 2 g/cm². The chamber is filled with methane and nitrogen (4%) at pressure of about 1 MPa. The chamber was operated in differential mode [1]. In this mode the collecting voltage in one half of the chamber is high and the ionization current is close to saturation. In the second half of the chamber the collecting voltage has a lower value, specially chosen so that the ionization current depends on the initial recombination of ions. The signal from the chamber is equal to the difference between this two currents and is proportional to the dose equivalent rate. For the purpose of this work the response of the chamber was defined as the ratio of the signal to $H^*(10)$.

METHOD

Response of the chamber to $H^*(10)$ was experimentally determined in three photon and two neutron fields: X-rays with effective energy 111 keV, gamma radiation of ^{137}Cs and ^{60}Co sources, the radiation of isotopic neutron sources $^{241}\text{Am-Be}$ and ^{252}Cf . The radiation fields were established in calibration room at the Radiation Protection Department of IAE Swierk. Exposure for photons and fluence for neutrons were well defined for all irradiation conditions. Ambient dose equivalent for photons was calculated by multiplying the exposure with the conversion factors for monoenergetic photons, given in the ICRP Publication 51 [2]. For isotopic neutron sources the conversion factors given by Bartlett were used [3].

The current of the ionization chamber was measured with a Keithley 642 electrometer connected to an automated system for the experiment control and data acquisition. Response of the chamber for some monoenergetic neutrons, over a neutron energy range from thermal to 19 MeV, was estimated on the basis of experimental results by Höfert and Raffnsøe [4]. Since the results had been expressed by authors in terms of MADE (according to ICRP 21 [5]), so the recalculation to the $H^*(10)$ was made. The conversion factors given in ICRP Publication 51 [2] and spline interpolation between given points were used for the recalculation.

PHOTON AND NEUTRON RESPONSES

Experimental results for photons and for neutrons from isotopic sources are given in Table 1. The relative response quoted in the Table is defined as the ratio of the chamber response for the radiation considered to the response for ^{137}Cs .

TABLE 1. Response of the REM2 recombination chamber to $H^*(10)$ for photons and for isotopic sources of neutrons.

Photon source	Neutron source	Correct. to photon emission	Effective energy E_T (keV)	Response to $H^*(10)$ ($\mu\text{C}\cdot\text{Sv}^{-1}$)	Relative response R/R_{Cs}
X-rays ^{137}Cs ^{60}Co			111	10.12	0.992
			662	10.2	1.000
			1250	10.51	1.03
	$^{241}\text{Am-Be}$ ^{252}Cf ^{252}Cf	no		10.2	1.0
		no		11.0	1.08
		yes		11.08	1.086

Uncertainties of the relative response values are of about 4% for photons and of about 8% for neutrons. This include the uncertainties of the exposure or fluence determination and stochastic uncertainty (expressed as one standard deviation) of measured ionization currents. Conversion factors are taken without uncertainties, however it should be noted that for neutrons this uncertainties may be as great as 10%.

It can be seen that for photons of energies considered the differences in responses of the chamber are very small. The second practically important fact is, that the response for $^{241}\text{Am-Be}$ neutron source is the same as for ^{137}Cs photon source. It was the reason, why the correction of response for photon emission was not needed in case of $^{241}\text{Am-Be}$ source.

The values of the response for monoenergetic neutrons, related to the response for $^{241}\text{Am-Be}$ source, are given in Table 2 and in Fig. 1. As it was mentioned above, the values were obtained by recalculation of earlier published results [4]. No assessment of uncertainties has been made for this case; the results are not considered to be unequivocal, but they can help to assess the applicability of the recombination chamber as an instrument for the ambient dose equivalent determination.

TABLE 2. Relative response of the REM2 chamber to $H^*(10)$ for neutrons (recalculated from data given in [4]).

Neutron source or energy (MeV)	Relative response $R/R_{\text{Am-Be}}$
Thermal	1.15
0.0245	2.46
0.1	1.19
0.25	1.19
0.57	0.94
1.0	1.14
2.5	1.22
5.0	0.89
15.5	0.53
19.0	0.64
^{252}Cf	1.096

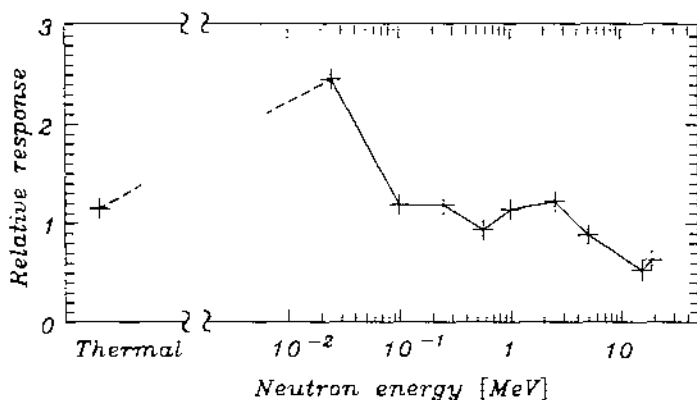

Fig.1 Relative response of the REM2 chamber to $H^*(10)$ versus neutron energy (related to $^{241}\text{Am-Be}$ source).

DISCUSSION AND CONCLUSIONS

As it was expected from general considerations, only minor differences in the response of the chamber were found for the photon radiations investigated. The experimental results are too poor to exclude that somewhat larger differences may appear for photons of other energies. Even though, this should not have any significant influence on the determination of $H^*(10)$ for mixed radiation fields, because the photon contribution to the dose equivalent is usually low.

A serious advantage of the chamber is the almost equal response for gamma radiation and for neutrons of $^{241}\text{Am-Be}$ source. Therefore, for determination of $H^*(10)$ in mixed neutron-gamma fields, the chamber may be calibrated either with $^{241}\text{Am-Be}$ source, or with ^{137}Cs source.

There is a number of factors which cause that the sensitivity of the commonly used T.E. chambers is lower for neutrons than for photons. In the REM2 chamber influence of these factors is compensated by an excess of the hydrogen content in the filling gas with respect to the T.E.-gas.

The usefulness of the recombination chamber in monitoring of the $H^*(10)$ depends primarily on the neutron energy dependence of the chamber response. Such a dependence for the REM2 chamber is given in Fig.1. It can be seen, that with respect to calibration with $^{241}\text{Am-Be}$ source, there is an overestimation of the $H^*(10)$ for neutron energies lower than 5 MeV and underestimation for higher energies. The overestimation for lower neutron energies, caused by the excess of hydrogen, does not exceed 20%, except of the 24.5 keV neutrons, where the relative response of almost 2.5 was observed. We are not able to find any explanation for so high overestimation at this neutron energy. With increasing energy of neutrons the effectiveness of the compensation decreases and $H^*(10)$ becomes to be underestimated down to the value of 0.53 for neutrons of energy 15.5 MeV. Taking into account the operating principle of the recombination chamber and the differences of the chamber construction comparing to the ICRU sphere, we expect that the relative response of the chamber will not decrease more, even for high energy neutrons. However this prediction needs further investigations.

For a broad neutron energy spectrum, which is the usual case in radiation protection practice, one can expect that the relative response of the chamber is sufficiently constant. Therefore a large recombination chamber, like the REM2, may be considered as a good detector of the ambient dose equivalent of mixed radiation in vicinity of isotopic sources and nuclear installations.

REFERENCES

1. Pszona S., Zielczynski M., Zarnowiecki K. Proc. of the First Int. Congress of Rad. Prot., Rome 1966, Pergamon Press, 1968, p. 813
2. ICRP Publication 51, Pergamon Press 1987
3. Bartlett D.T., Rad.Prot.Dosim. Vol. 15 No. 4 (1986) 273
4. Höfert M., Raffnsøe C. Nucl.Instr. and Meth. 176 (1980) 443
5. ICRP Publication 21, Pergamon Press, New York 1973

Frequency Sweep ESR Spectrometer for Dosimetry and Dating

Hidemoto Hara*, H. Morishima**, H. Kawai**and Y. Nishiwaki**.

* Micro Device Co.,Ltd.

1-2-6 Komagome Toshima-ku, Tokyo 170, Japan

** Atomic Energy Research Institute of Kinki University

3-4-1 Kowakae, Higashi-Osaka City, Osaka 577, Japan

For the study of radiation damage in matter, ESR (Electron Spin Resonance) is widely used these days and much progress has been achieved in the method of measuring ESR signals. However, with the standard type ESR equipment, a large electromagnet and regulated power supply are set up and quite a large area is required in the laboratory. Therefore, it is impossible to conduct an experiment on site outside the laboratory with such a large equipment. For dosimetry with such a large ESR equipment it is required that the samples to be used for ESR-dosimetry have to be brought back to the laboratory for measurement. In order to facilitate the ESR measurement on site outside the laboratory in nuclear accident or emergency or for the purpose of dating of ancient natural samples at remote places, we are trying to build an experimental, small-sized ESR equipment, which is capable of transforming into a battery powered portable version.

With the first type of portable ESR spectrometer which was developed, the feasibility as a reader of alanine dosimeter was studied. The developed ESR spectrometer was designed to be small enough that it can be placed on a two-feet-square desk, however it has the functions of high magnetic field modulation, high frequency modulation, variable amplitude and AFC(Automatic Frequency Control)function in order not to sacrifice sensitivity, stability and reproducibility. The spectrometer has

two main components of a permanent rare-earth metal magnet and resonator part, and a unit box with a microwave circuit, an AFC circuit, a sweep controller of magnetic field, an oscilloscope, etc. Sensitivity was improved by using FET (Field Effect Transistor) amplifier in a resonance detector circuit.

With the second type of portable ESR spectrometer, it is intended to measure ESR signals of shell goods such as button and human teeth which were irradiated by nuclear radiation accidentally. For this purpose we are trying to develop ESR equipment using a strong permanent magnet and microwave modulation. Conventional ESR equipment consists of a system whereby resonance is detected by fixing the microwave frequency and sweeping the magnetic field, while the equipment we are trying to develop uses the method whereby ESR signal is detected by fixing the magnetic field and sweeping the microwave frequency. The high Q-value sample cavity has been coupled with the low Q-value oscillation cavity through the iris hole. Voltage impressed to the tuning diode inside the sample cavity gives shift to the resonance frequency, simultaneously controlling the oscillation frequency. About 100 megahertz frequency sweepings have been used by giving trapezoidal modulation. Magnetic field has been fixed to an adequate value by controlling the gap of the permanent magnet.

At present, the sensitivity of this equipment is too low to be used for the measurement of low radiation dose range for routine radiation protection purposes. Therefore, it is now intended to develop an equipment to be used to screen the persons who would have received unusually high dose of radiation accidentally in case of nuclear accident or emergency. In such cases, ordinary dosimeter designed for measurement of low dose of radiation for routine radiation protection purposes may not be usable. Under such emergency cases, ESR equipment must be brought as close to the site of accident as possible, in order to facilitate the

prompt screening of the persons who are exposed to unusually high dose of radiation, using ESR signals of shell button, sugar coating of the medicine carried by the person or human teeth if available. We are now trying to improve the sensitivity and reproducibility of this type of portable equipment.

References

- 1) Y. Nishiwaki, H. Hara, T. Shimano, T. Nakajima: ESR Dosimeter for the Public in Nuclear Emergency. Proceedings of the International Conference "Emergency '88" London, 1988.
- 2) Y. Nishiwaki and T. Shimono: Uncertainties in Dose Estimation under Emergency Conditions and ESR Dosimetry with Human Teeth, Proceedings of the Ninth International Conference on Solid State Dosimetry, 295-297, Seibersdorf, Austria (1990) .
- 3) T. Nakajima, Y. Nishiwaki et al.: ESR Sensitivity Comparison of Sugar from Various Sources and Cavity Mode Effect, Proceedings of the Ninth International Conference on Solid State Dosimetry, 303-306, Seibersdorf, Austria (1990) .
- 4) H. Hara, Y. Nishiwaki et al.: Frequency Sweep ESR Spectrometer for Dosimetry and Dating, Proceedings of the Ninth International Conference on Solid State Dosimetry, 335-337, Seibersdorf, Austria (1990) .

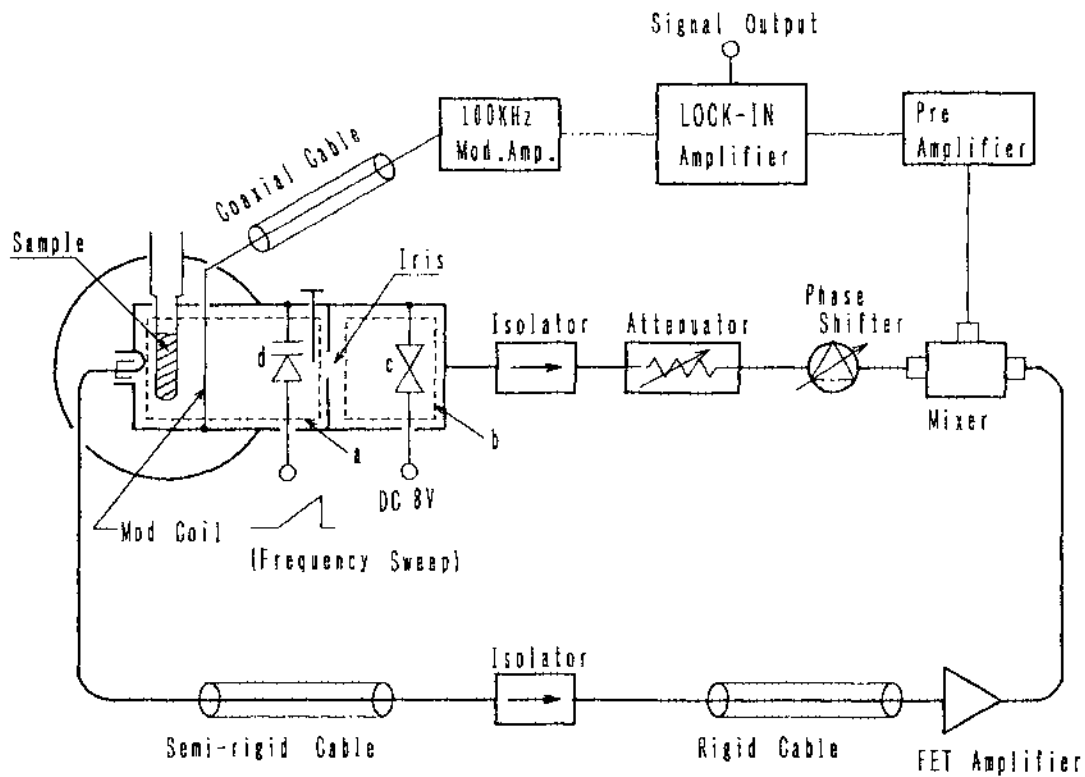

a: Sample Cavity c: Gunn Diode
 b: Oscillation Cavity d: Tuning Diode

<Frequency Sweep ESR Block diagram>

MERLINS vs BNFL : A CLAIM FOR DAMAGE TO PROPERTY BY RADIOACTIVITY

S R Jones and J A Coote

British Nuclear Fuels plc,
Sellafield, Seascale, Cumbria, UK.

A J Shuttleworth

British Nuclear Fuels plc,
Risley, Warrington, Cheshire, UK.

ABSTRACT

A case heard in the High Court, London in 1989 tested the provision for strict liability imposed by the Nuclear Installations Act 1965, in respect of damage caused by radioactivity emanating from a nuclear licensed site. Plaintiffs were Mr and Mrs Merlin of Moutain Ash, Ravenglass, Cumbria; defendants were British Nuclear Fuels plc, nuclear site licensees for the Sellafield reprocessing plant.

Both sides agreed that housedust in the property contained about 350 Bq kg⁻¹ actinides, attributable to discharges from the Sellafield plant; assessments of consequent dose and risk to the occupants diverged considerably.

The judge concluded that, since physical damage to the property had not occurred, the claim, made pursuant to the provisions of the Nuclear Installations Act 1965, must fail. Moreover, he indicated a strong preference for the defendant's assessment of resulting dose and risk, at no more than about 100 μ Sv yr⁻¹ (effective dose equivalent) or a risk of about 10⁻⁶ per year.

LEGISLATIVE BACKGROUND

In the United Kingdom, the Nuclear Installations Act 1965 is the primary legal instrument for regulating the operation of large nuclear installations. In addition to defining the regulatory framework, it also places a strict liability on the site licensee for any damage caused by nuclear matter (ie radioactive materials) handled on the site.

This strict liability had been tested in civil proceedings relating to damage to the health of employees (cancer cases), but prior to 1989 there had been no test of this provision in respect of off-site effects.

THE CLAIM

The plaintiffs in this case had lived in the village of Ravenglass, about 15 km south of the Sellafield nuclear fuel reprocessing site, since the early 1970s. Their house immediately overlooked the Ravenglass estuary, the sediments of which contained enhanced levels of fission products and actinides as a consequence of discharges from the Sellafield plant.

On two occasions, once in the late 1970s and subsequently in the early 1980s, the plaintiffs had samples of their housedust analysed for radioactivity. These measurements clearly showed the presence of radionuclides emanating from Sellafield, including the actinides plutonium and americium at combined concentrations of around 350 Bq kg⁻¹.

The plaintiffs expressed concern at these findings and decided to move from the village. They found their house difficult to sell and it did not realise the price they expected; the situation was complicated by the screening of a television documentary which raised a number of concerns regarding emissions from Sellafield, and which featured the plaintiffs and the issue of radioactivity in their housedust.

The plaintiffs then embarked on proceedings in the civil courts, citing the levels of radioactivity in their house and its alleged low value on the market as justification for a claim of damage to property under the absolute liability provision of the Nuclear Installations Act 1965.

The defendants conceded that concentrations of radionuclides in the housedust were at the levels pleaded by the plaintiffs, and that the fission product and actinide component resulted almost wholly from discharges from the Sellafield plant. They however contended that the property had not been damaged, nor had there been a significant risk to the health of the occupants. Surveys of radioactivity in housedust in the area, together with assessments of resulting doses (1,2) were cited; these showed that radionuclide concentrations in the plaintiffs property were at the high end of, but within, the range for other properties in the area.

The case was heard in the High Court in London during the autumn and early winter of 1989, taking some three months.

COURT EVIDENCE AND ARGUMENTS

The case involved argument both about points of law and about radiological protection science.

In regard to the law, the plaintiffs argued that any contamination of their property amounted to damage, that due to the contamination the premises ceased to be of any use or value as a home, and/or that they were obliged to sell the property at an under-value. In the alternative, they argued that there was a significant risk to health presented by radioactivity in the housedust and the property must thereby be damaged. The defendants contended that loss of value by itself was as pure economic loss not actionable; that no demonstrable physical damage to property had occurred and that there was therefore no basis for a claims. In the alternative, they contended that the risk to health from radioactivity in the house was so low as to be insignificant.

Much of the court's time was taken by considering the arguments regarding health risks. Experts for the plaintiffs and defendants had assessed the likely radiation doses and consequent risks to the occupants of the property; these assessments were a long way apart.

The plaintiffs suggested that doses as high as $10-20 \text{ mSv y}^{-1}$ to the lung could result, leading to a doubling of the lung cancer risk for a non-smoker spending a lifetime in the property; the defendants concluded that lung dose would not be the limiting factor, that doses were likely to be 0.1 mSv y^{-1} (effective dose equivalent) at most; and that lifetime risks were unlikely to exceed 1 in 10^4 . The only area of agreement was that intake of actinides, by inhalation or ingestion, was the most significant factor.

The technical arguments were structured by considering separately the intake of radionuclides; estimation of doses to organs and effective dose equivalent; and estimation of consequent risks.

The defendants estimates of intake rested on a simple model which supposed that the air in the house might contain $100 \mu\text{g m}^{-3}$ of suspended housedust and that a person might inadvertently ingest 100 mg d^{-1} of housedust. These figures emerged as reasonable from the earlier mentioned studies (1,2) and from other literature (eg 3,4). The plaintiffs adopted a quite different approach but their assumptions on intake were shown to depend on the dust suspended in air consisting almost entirely of fine estuarine sediment, with a specific activity many times that of housedust, and at a mass loading substantially in excess of $100 \mu\text{g m}^{-3}$. These assumptions produced erroneously high values for the activity concentration in air for houses in which both housedust activities and air concentrations had been measured (1,2); moreover studies specially commissioned by the defendants (5) provided support for the loading figure of $100 \mu\text{g m}^{-3}$, and showed that even the finest component of housedust ($<1.5 \mu\text{m AMAD}$) had a specific activity only twice that of the bulk sample.

For dosimetric calculations, the defendant's experts depended on standard dosimetric models (6,7). By contrast, the plaintiff's expert focused on the estimation of doses to lung. In particular, the plaintiffs expert argued that the current ICRP lung model is inadequate, particularly for alpha emitters, in that it calculates dose to the lung as a whole; since (it was argued) the bronchial epithelium, and in particular the epithelium at bronchial bifurcations, is the tissue in which lung cancers arise then the dose to this component must be estimated specifically. Much debate centred on this point, and the defendants commissioned an expert's report from the Task Group on Lung Dynamics, which has recently proposed a revised lung model to ICRP (8). The defendants conceded that the present lung model is too simple, but noted that much of the dose in their expert's calculations resulted from transfer of actinides out of the lung since class W behaviour (most conservative in ICRP 30 dosimetry) had been assumed. Moreover several aspects the plaintiff's non-standard estimate of dose to the bronchial epithelium were questioned and compared unfavourably with calculations carried out by the Task Group.

In assessing risks, the plaintiff's expert took their estimate of radiation dose to lung and derived a dose/risks relationship largely from a single study of Swedish iron ore miners (9), claimed to be more complete in terms of follow-up than other studies.

By contrast, the defendants experts took their lower estimates of dose (including dose to organs other than lung) and derived dose/risk relationships from the usual, much wider, range of epidemiological studies (eg 11,12).

THE JUDGEMENT

On the points of law, the judge concluded that the strict liability provisions of the Nuclear Installations Act apply only to personal injury or to physical damage to tangible property; they do not apply to economic loss or to the imposition of a risk to health, that is an enhanced probability of future personal injury. On that basis alone the judge concluded that he must find for the defendants.

However, lest his judgement on law should be reversed on appeal he gave an assessment of both the magnitude of damages, which he concluded to be substantially less than the plaintiffs claimed, and the scientific evidence. He concluded that the defendant's assessments of dose and risk were to be

much preferred and that the plaintiffs had failed to establish that the risk to health was anything other than trivial.

The plaintiffs did not appeal against the judgement.

CONCLUSION

It is impossible in a short paper to describe adequately the complex technical arguments in this case. It seems, on the face of it, incredible that a radiological assessment of the significance to be attached to two measurements of radioactivity in housedust could occupy two months in a court of law.

One of the reasons is that apparently simple assessments of this type are underpinned by an extensive structure of assumptions and models dealing with methods of assessing intake, dosimetry, and dose/risk relationships. Experts from both sides would agree that the examination of scientific evidence was thorough and thought-provoking.

In this case conventional radiological protection methodology carried the day, but significant questions were only partially answered, particularly in regard to the details of lung dosimetry and lung cancer aetiology.

REFERENCES

1. Fry, Green, Dodd and Hammond: Radionuclides in housedust. NRPB R181, HMSO (1985).
2. Goddard, Minski, Thornton and Culbard: Household particulate survey. DOE/RW/8073, DoE London (1986).
3. La Goy: Estimated soil ingestion rates for use in Risk Assessment. Risk Analysis 7 8 355-359, 1987.
4. Dockery and Spengler: Indoor-Outdoor relationships of respirable sulphates and particles: Atmospheric Environment 15 335-343 (1981).
5. Garland, Playford, Carpenter and Jones: to be published.
6. ICRP Publication 30: Annals of the ICRP 2 3/4 (1970).
7. National Radiological Protection Board report NRPB-GS7: NRPB, Chilton (1987).
8. James and Birchall: Progress in lung modelling by the ICRP Task Group. Radiat. Prot. Dosim. 26 227-235 (1989).
9. Radford and Renard: Lung cancer in Swedish iron miners exposed to low doses of radon daughters. N.Engl. J.Med. 310 23 1485-1494 (1984).
10. UNSCEAR: Sources, effects and risks of ionising radiation. United Nations, New York (1988).
11. NRC: Health risks of radon and other internally deposited alpha emitters, BEIR IV. National Academy Press, Washington DC (1988).

M. CHRISTIAN BATAILLE

LA GESTION DES DÉCHETS NUCLÉAIRES À HAUTE ACTIVITÉ *LES RESPONSABLES POLITIQUES FACE AUX RISQUES DES RAYONNEMENTS IONISANTS*

L'étude des effets des rayonnements ionisants sur les êtres vivants a commencé il y a près d'un siècle et les premières normes internationales en ce domaine ont été édictées il y a plus de 60 ans.

Il ne s'agit donc pas d'un problème nouveau. Malgré tout, les responsables politiques qui sont en permanence en contact avec la population constatent régulièrement que la perception de ces risques par le public repose toujours en grande partie sur des éléments irrationnels.

Alors que le monde moderne vit de plus en plus au milieu des rayonnements ionisants, de la production d'énergie nucléaire, de la médecine ou de l'industrie, il apparaît toujours aussi difficile de communiquer sur ces sujets.

Or, les responsables politiques ont de plus en plus souvent à prendre des décisions, ou parfois à supporter les conséquences de décisions, que le public considère, à tort ou à raison, comme susceptibles d'entraîner des risques liés aux rayonnements ionisants.

Il faut d'ailleurs remarquer que cette situation n'est pas propre au nucléaire. Sur de nombreux points, nos sociétés contemporaines pourtant largement imprégnées par la science et la technique apparaissent à beaucoup de nos concitoyens comme moins sûres que les sociétés traditionnelles où les risques objectifs étaient pourtant plus nombreux et plus graves.

L'évolution des sciences et des techniques n'a pas comme on l'espérait encore dans les premières années de ce siècle, rendu le monde plus intelligible et moins inquiétant à la majorité des hommes.

Il existe même dans nos sociétés une étrange dissymétrie entre les dangers réels et la perception des risques pour la population.

Ce qui inquiète nos concitoyens, ce ne sont pas les accidents de voiture ou les maladies liées à l'alcoolisme ou au tabagisme qui font cependant des dizaines de milliers de morts chaque année, mais plutôt des menaces imprécises et mal identifiées liées à des techniques dont ils ne comprennent pas bien les tenants et les aboutissants.

Il y a des discours que la société est prête à entendre et d'autres pas.

Si nous nions - lors de la prise de décisions politiques - tous les aspects irrationnels qui déclenchent ces peurs et ces rejets, les réactions de nos mandants nous obligent alors souvent à réviser brutalement nos positions antérieures.

Il faut bien admettre que, dans l'ensemble, de ces peurs et de ces rejets les risques liés à la radioactivité tiennent une place à part quels que soient les efforts que déploient les autorités pour tenter de banaliser le nucléaire.

Dans un pays qui, comme la France, a relativement bien accepté le développement d'un programme nucléaire ambitieux, il est assez curieux de constater que tout ce qui concerne les rayonnements ionisants continue à susciter une inquiétude tout à fait particulière bien souvent totalement irréductible aux arguments et aux démonstrations des spécialistes et des experts.

Cela tient peut-être aux caractères spécifiques des rayonnements ionisants impossibles à voir et même à détecter avec des moyens ordinaires.

L'utilisation militaire de l'atome n'est certainement pas non plus étrangère à cette défiance envers des techniques qui peuvent aussi servir à des destructions massives.

Nous avons été, en France, confrontés il y a quelques mois à une réaction de rejet de la population qui a d'autant plus surpris qu'elle n'était pas conforme à l'attitude que nos concitoyens avaient en général adoptée jusque là, face au nucléaire.

Alors que le programme nucléaire français s'était développé pratiquement sans opposition, les tentatives d'implantation des laboratoires souterrains destinés à étudier le comportement des déchets nucléaires à haute activité en couches géologiques profondes ont été violemment contestés par une importante partie de la population.

Malgré de notables efforts de communication, ni les experts scientifiques, ni les dirigeants des organismes chargés de la gestion des déchets nucléaires n'ont réussi à convaincre les populations concernées du peu de dangers objectifs que présenterait l'enfouissement des déchets nucléaires et le gouvernement a dû se résoudre à suspendre les travaux de recherche.

Les responsables politiques français se sont donc retrouvés tout à coup confrontés, sans y être véritablement préparés, aux problèmes posés par la perception des risques des rayonnements par le public.

Or, ces problèmes posent un véritable dilemme à ceux qui sont en charge de la conduite des affaires de l'Etat :

- faut-il tenir compte des craintes, même irrationnelles de la population ?
- ou faut-il au contraire privilégier la poursuite du développement de l'industrie nucléaire ?

Même si elles ne sont pas toujours scientifiquement justifiées, les craintes de la population face aux risques des rayonnements sont un fait qui s'imposera de plus en plus aux responsables politiques d'autant que les experts sont pour le moment incapables de fournir une explication simple et rassurante sur les effets stochastiques des faibles doses de radioactivité.

Quelle serait en effet la responsabilité des gouvernants s'il s'avérait un jour que les faibles doses de rayonnement qu'ils ont autorisé avaient des effets pathogènes irréversibles ?

Mais d'un côté, il faut bien, à partir du moment où l'on accepte le recours à l'énergie nucléaire, tolérer certains rejets radioactifs dans l'environnement.

Les responsables politiques doivent donc en permanence arbitrer entre ces deux contraintes tout en s'efforçant d'améliorer l'information du public.

Placé dans une situation de blocage pour lesquels les mécanismes habituels de négociations se révélaient inopérants, le Gouvernement a alors exprimé le souhait que l'Office parlementaire d'évaluation, organisme qui dépend uniquement du Parlement, procède à une étude et recherche les solutions susceptibles de permettre la reprise du dialogue avec les populations concernées.

Au cours de cette enquête qui a duré sept mois, toutes les opinions ont été entendues sans exclusive et sans limitation.

Il ne s'agissait pas pour le rapporteur de l'Office de tenter de refaire les multiples travaux scientifiques existants mais plutôt d'essayer de comprendre pourquoi la peur de la radioactivité pouvait conduire au rejet d'un projet présenté comme sûr par pratiquement tous les experts.

Il est très rapidement apparu qu'une des causes de cette attitude négative tenait à l'ignorance dans laquelle on avait tenu nos concitoyens vis-à-vis des problèmes de radioprotection.

Je connais bien les efforts que des organismes comme l'Association Internationale de radioprotection ou comme la Société française de radioprotection font depuis plusieurs décennies pour informer le public sur les notions de base de la protection contre les rayonnements ionisants mais les contacts que j'ai pu avoir sur le terrain m'ont démontré que l'information en général ne passait pas.

Selon moi, cet échec ne doit pas être imputé aux spécialistes, qui un peu partout dans le monde font correctement leur travail, mais aux responsables politiques qui n'ont pas pris les dispositions nécessaires pour que l'information sur la radioactivité puisse effectivement atteindre le grand public et être acceptée par lui.

Pour qu'une information passe dans une population, il faut en effet que celle-ci soit apte à la recevoir et qu'elle ait confiance dans ceux qui la délivrent.

Comme le notait l'Académie des sciences française : "De tous les agents potentiellement toxiques de notre environnement, les rayonnements ionisants sont sans doute ceux dont les effets sont les mieux connus et qui font l'objet du plus grand nombre de travaux expérimentaux et d'enquêtes épidémiologiques".

Cela est parfaitement exact mais il n'en demeure pas moins que la perception des risques éventuels pour la population ne correspond pas aux messages que les autorités et les experts souhaitaient faire passer.

La première raison tient certainement à l'insuffisance de la formation initiale des individus sur tout ce qui concerne la radioactivité. Alors que nous vivons et que nous vivrons dans un monde de plus en plus nucléarisé, la majorité

d'entre nous ignore jusqu'aux bases mêmes de la radioactivité, d'où une exclusion de fait des débats et un rejet en bloc des arguments des experts.

Un sondage effectué en France il y a quelques années a d'ailleurs montré que l'inquiétude vis-à-vis du nucléaire diminuait à mesure que l'on se rapprochait d'une installation nucléaire, certainement parce que les habitants sont alors mieux informés de la réalité des risques.

La deuxième raison qui est peut-être en grande partie spécifique à la France c'est que toutes les questions qui concernent les risques des rayonnements ionisants n'ont pas été traitées avec suffisamment de transparence et de démocratie.

Les questions ont longtemps été considérées comme un problème purement technique qui devait donc être traité entre spécialistes dans la discrétion, voire la dissimulation.

Les faits ont montré que c'était une erreur et qu'elles étaient devenues en peu de temps un problème de société.

Très fréquemment désormais, en France et dans les autres pays économiquement développés, des choix que l'on considérerait d'ordre technique donnent tout à coup naissance à des controverses d'ampleur nationale.

Les administrations en charge du dossier constatent souvent avec retard que certains problèmes ne peuvent être résolus par la seule approche technique et qu'il faut solliciter le niveau institutionnel et politique pour prendre position, ou au besoin pour arbitrer.

Dans les démocraties modernes, certaines dispositions contraignantes ne peuvent être imposées, s'il n'existe pas de consensus, qu'après un large débat où tous les intérêts, toutes les opinions ont pu se faire entendre.

Cela ne veut pas dire que les scientifiques et les techniciens, tous ceux qui savent doivent être écartés du débat mais simplement que d'autres arguments que les leurs doivent aussi se faire entendre.

Le débat entre hommes de science ne peut prendre en compte que des analyses rationnelles construites à partir de faits prouvés. En sont donc exclus les risques hypothétiques ou non démontrables, les peurs irrationnelles, et même l'éthique et la morale.

Le monde change, le citoyen ne reste plus passif devant les choix faits par d'autres qu'on voudrait lui imposer. S'il est mal informé des enjeux véritables, il se réfugie dans une opposition aveugle et souvent violente.

Parmi les problèmes de civilisation qui vont se poser de façon cruciale dans les années qui viennent, le nucléaire tiendra certainement la première place.

Le mystère qui entoure encore cette forme d'énergie mais aussi le goût du secret qui a été cultivé pendant trop longtemps par ses responsables font qu'aujourd'hui la France, après la plupart des autres pays développés, risque de se trouver dans une impasse.

Il n'y aura pas de poursuite du programme nucléaire sans une très large acceptation de la population.

En conclusion, je reprendrai les observations que j'ai présentées au Parlement français dans mon rapport sur les déchets nucléaires à haute activité.

Responsabilité, transparence et démocratie sont les mots qui doivent désormais guider notre démarche pour tout ce qui concerne la radioactivité et en particulier dans le domaine de la radioprotection.

RESPONSABILITÉ : car les responsables politiques doivent réellement s'impliquer dans ces questions qu'ils avaient par trop tendance à abandonner aux spécialistes. Ces derniers bien entendu doivent pouvoir continuer à déterminer librement les critères scientifiques de la protection des populations et de l'environnement mais c'est aux hommes politiques de fixer les règles qui sépareront clairement ce qui est interdit de ce qui peut être toléré.

Une politique de radioprotection doit s'appuyer sur des données techniquement et scientifiquement fiables et rigoureuses mais elle doit aussi s'attacher à ne mettre en oeuvre que des solutions socialement et politiquement acceptées.

TRANSPARENCE : les années 90 doivent marquer la fin de la culture du secret en matière nucléaire, les origines militaires de cette industrie expliquent peut-être cette persistance agaçante d'une culture du secret qui ne se justifie plus quand la quasi totalité des habitants du pays développé bénéficie déjà de l'énergie nucléaire. Nous avons besoin désormais d'une approche transparente.

DÉMOCRATIE : car jusqu'alors une méthode autoritaire et administrative a souvent prévalu. Elle a pu correspondre au début du développement de l'énergie nucléaire. Sans remettre en doute la capacité des chercheurs et techniciens, elle a comporté le risque de céder à un vertige technologique et scientiste. Aujourd'hui les choses sont différentes, le public exige des informations et demande à contribuer aux décisions. **IL FAUT DONC DÉSORMAIS EMPRUNTER UN CHEMIN DIFFÉRENT** faisant appel aux ressources de la démocratie et de l'information. A cette forme sophistiquée de production d'énergie qu'est le nucléaire doit correspondre un processus ouvert de décision.

L'avenir de l'énergie nucléaire dépend de notre capacité à développer la Démocratie.

**Information for the public on nuclear safety in the
European Community: Regulations and Practices**

**H. ERISKAT – D. TEUNEN
Commission of the European Communities
DG XI-A-1 Radiation Protection**

La Commission Européenne est active dans le domaine de l'information en radioprotection pour le public:

- par un instrument légal, contraignant pour les Etats Membres, c'est à dire la directive information en cas d'une urgence radiologique (89/618/EUR),
- par des actions de support, comme des vidéos, brochures, etc.

* * *

This paper describes the work of the Commission of the European Communities in training and information in radiation protection.

The radiation protection has a long European pedigree.

In 1957 the Euratom Treaty established the European Atomic Energy Community, and one of the principal tasks attributed to the Community in the field of radiation protection was the preparation of uniform safety standards for protection of the population and of workers, and the monitoring of their application.

Training and information have remained and will continue to remain an integral component of the Standards. This Community precedent has led to radiation protection being taken as a model in other sectors.

Since 1975 the Commission has also organized conferences on training and information, attended by radiation protection specialists, and by representatives of the competent authorities and of the trade unions.

At the same time opinion polls on the risk perception by the population on the degree of satisfaction with information on radiation protection was performed in 1988 and 1989.

These consultations resulted in several support actions, such as the informative booklet "Radiation and You", videotapes, etc.

The Commission's action as regards public information is likewise based on the Euratom Treaty and on a legal instrument, responsibility for the matter having been conferred on the Commission by the Council Directive of 27 November 1989 on informing the general public about health protection measures to be applied and steps to be taken in the event of a radiological emergency (89/618/EUR). This directive seeks to define common objectives for informing the general public about health protection measures to be applied and steps to be taken in the event of a radiological emergency, and is partially based on the experience gained by the Commission with the so-called Seveso directive of 24 June 1982 on the major accident hazards of certain industrial activities (82/501/EEC). The deadline for implementing was 27 November 1991.

This public information obligation is specified in articles 5 and 6 of this Directive.

Article 5.1 reads,

Member States shall ensure that the population likely to be affected in the event of a radiological emergency is given information about the health-protection measures applicable to it and about the action it should take in the event of such an emergency.

The purpose of this provision is clearly not to define the geographical areas concerned, but to ensure that information is provided only if the authorities can assure the population that adequate measures have been planned. The population should be informed only if it is covered by an intervention plan.

Article 6 reads:

Member States shall ensure that, when a radiological emergency occurs, the population actually affected is informed without delay of the facts of the emergency, of the steps to be taken and, as appropriate to the case in point, and of the health-protection measures applicable to it.

In the event of a real radiological emergency, information must be provided systematically, rapidly and openly in order to encourage the population actually affected to adopt the appropriate behaviour. This cannot be achieved without obtaining the confidence of the population.

As laid down in Article 6(1), the information must be provided without delay, since lack of information and ignorance of the facts may produce anxiety and unforeseeable reactions on the part of the general public. The Member States can therefore, if appropriate, begin informing the population at the pre-alarm phase.

The most direct sources of information should be used (national, regional and local press and radio, television, direct answers by telephone and, if appropriate, computerized magazines such as teletexts).

Every step should be taken to ensure that sources of information are not giving contradictory information, e.g. by creating or appointing a national information dissemination agency with a coordinating function.

Overview of the implementation of the Directive 89/618/EURATOM.

Here we summarize, as an example, the situation in some E.C. countries:

Federal Republic of Germany

The legislation on planning for emergencies states that the Länder are responsible for establishing emergency plans. In 1975 (an updated version appeared in 1988) they negotiated with the Federal Government the "framework recommendations for contingency planning in the neighbourhood of nuclear installations", which set out the criteria to be met by emergency plans, as well as the warnings and information to be given to the public in the event of an accident.

Belgium:

The province governors are the competent authorities in the event of emergencies.

A national emergency plan which has been adopted on..... serves as a model for the various existing provincial emergency plans. Since the national emergency plan has been published, the population is able to familiarize itself with the broad outlines of the emergency plan. The national plan provides for both prior information and information in the event of an accident.

France:

Article 5 (prior information)

Information brochures have been distributed in the region of the 25 nuclear sites. The authorities think that this information campaign should be repeated every five years in view of the mobility of the population.

Since 6 May 1988 all the intervention plans specific to given installations are available for consultation at the relevant Prefectures and town halls. Information in schools in certain regions of France with nuclear installations can constitute an example of prior information, since the process must start with the very youngest children.

Article 6 (information in the event of an emergency)

By virtue of a decree adopted in mid-May 1990, the authorities can use the radio stations on the basis of agreements concluded with them.

A nuclear event scale has been adopted to facilitate relations with the media. It applied to power plants and has been extended to other fuel-cycle installations.

Ireland:

A non-regulatory, administrative emergency plan has been drawn up setting out the responsibilities of each ministry. This will be published and made available to the public.

In the event of an accident, an inter-ministerial expert committee would be convened to draw up communiqués to the Government on the question of information.

Portugal:

The Emergency plan is the responsibility of the National Service for Civil Protection. Public information is the responsibility of the Committee on Protection against Ionizing Radiation and the regional health authorities.

The Ministry of Environment is responsible for information on transfrontier emergencies.

United Kingdom:

The Department of the Environment is responsible for emergency measures in the event of an accident outside British territory, while the Department of Energy is the responsible body in the event of an accident occurring on British territory.

Conclusions

From this brief overview it can be concluded that:

- in the majority of Member States specific regulations are being drafted governing information for the public on radiation protection; this should result in a better coordination between national and local authorities involved;
- the communication technology necessary for achieving the aims of the Directive has to be established or developed;
- a suitable terminology has to be developed to ensure both transparency of information and an understanding of the various levels of risk, without over-dramatizing the situation.

The initiatives already taken included such appropriate measures as agreements with the media, the establishment of a nuclear event scale and the publication of emergency plans.

Ref: Council Directive of 27 November 1989 on informing the general public about health protection measures to be applied and steps to be taken in the event of a radiological emergency (89/618/EUR).

Jacques LOCHARD

Centre d'études sur l'Évaluation de la Protection dans le domaine Nucléaire (CEPN)
BP 48 - 92263 Fontenay Aux Roses Cedex, France, Tél. (1) 46 54 86 65, Fax. (1) 46 57 62 58

L'intégration des valeurs sociales et éthiques dans la gestion du risque radiologique

Thème n° 2 : La perception des risques des rayonnements

Présentation : orale

Les modalités de gestion du risque radiologique à une époque donnée traduisent à la fois l'état des connaissances sur les effets des rayonnements mais également les idées dominantes concernant la perception et les pratiques sociales en matière de contrôle des risques en général. Ainsi, après avoir été dominé pendant plusieurs décennies par le modèle du seuil, une évolution profonde s'est opérée avec l'adoption du paradigme de l'optimum à la fin des années soixante-dix. Les développements les plus récents montrent cependant la nécessité de dépasser le strict plan de la rationalité économique pour inscrire la gestion du risque radiologique dans le cadre plus large de l'acceptabilité sociale des risques industriels et technologiques.

De ce point de vue, l'expérience montre qu'au-delà d'une réelle complexité, les phénomènes d'aversion au risque, ainsi que les attitudes sociales face au temps et à l'équité se retrouvent dans de nombreuses situations auxquelles les responsables de la radioprotection doivent faire face. Bien qu'il apparaisse indispensable de traduire en termes pratiques ces facteurs, à ce jour, les tentatives d'intégration dans la gestion du risque radiologique restent limitées et peu probantes.

L'objectif de la communication est de proposer une démarche, pour essayer de remédier à cette situation, qui s'appuie sur les travaux entrepris au CEPN dans le cadre d'un contrat de recherche supporté par la Commission des Communautés Européennes (DG XII). Bien qu'encore parcellaires, les premiers résultats permettent de dégager quelques principes généraux quant à la démarche méthodologique. Des exemples relatifs au traitement de l'aversion et au temps sont présentés à titre d'illustration.

'AT-A-GLANCE' BROADSHEETS, AN APPROACH TO PUBLIC INFORMATION

M J Gaines

National Radiological Protection Board,
Chilton, Oxfordshire, UK

ABSTRACT

The At-a-Glance series of broadsheets uses illustrations as the main information carrier but is underpinned by the results of scientific work. The clarity of the presentation, together with attractive design and printing and the association with science, has produced publications with great appeal to laymen. Some 500,000 broadsheets have been produced, many to meet the demand for bulk supplies for other organisations.

INTRODUCTION

NRPB has a well-established system of publications but most of them are far too technical for laymen. Even the booklet, 'Living with Radiation', is too advanced for the non-scientist, although it does provide a useful introduction for other technical, non-radiation protection, professionals. To avoid the jargon of radiation protection, NRPB therefore created the 'At-a-Glance' series of broadsheets in which illustrations are used to communicate most of the information - they are not just used to support text.

A major means of communicating the scientific output of NRPB is often a conference paper or a journal article, and therefore the organisation is very experienced in the use of visual aids. When we were considering how best to improve our communications with laymen, particularly people such as elected representatives on local authorities, we determined how best to use the skills we already had in presenting quantitative information visually. The idea of a series of broadsheets, in which visual materials dominate, was developed in 1989 and the first in the series was published towards the end of that year. Since then, over 500,000 have been produced.

THE MAIN SERIES

The series has developed over this time but the illustrations remain the principal means of telling the story, with the captions supporting them; and - equally important - each one is underpinned by the science.

Initially, four broadsheets were produced. Two of these are about broad aspects of radiation protection and two are about NRPB.

With the title 'Radiation Protection', one leaflet summarises the basic ideas of radiation protection as a starting point for other leaflets in the series. The ideas are grouped under sequential headings: atoms, radiation and radioactivity, radiation and tissue, radiation effects, harm and sensitivity, radiation protection principles, radiation protection in the UK, and how effective?

'Radiation Doses - Maps and Magnitudes' shows visually the main sources of radiation exposure, natural and man-made, and the average and the range of doses. The enormous variation in doses across the country is lucidly set out - indeed, one of the aims of the leaflet is to help lay readers to appreciate just how great the variation is. The graphics are based mostly on data contained in an NRPB report⁽¹⁾.

In 'NRPB at a Glance', pictures of NRPB staff at work are arranged under a linked series of scientific ideas: source of radiation exposure, environmental transfer, doses to people, dose distribution, and estimation of health effects; NRPB's role in standards is summarised.

'Partners in Protection' illustrates the way NRPB works with the

European Communities, industry, local authorities, central government, other professionals, etc. It is a striking characteristic of NRPB that it acts as a focal point for a large and varied number of organisations.

In 1990 a fifth broadsheet, 'Radon', was published. It describes the characteristics of radon, the means by which it builds up in homes, the nature and level of the risks, the remedies and preventative measures, and the problems posed by and solutions to radon in the workplace.

In 1991, four more broadsheets, were published.

'Transport of Radioactive Materials' summarises the use of radioactive materials to explain why transport is essential. It then describes the types of packages and containers used, outlines the modes of transport, and illustrates with pie diagrams and bar charts the radiation doses received during routine transport operations and those arising from accidents; these illustrations are again based on data in NRPB and other publications^{(1),(2),(3)}.

'Non-ionising Radiations' illustrates the types of sources of these radiations across the electromagnetic spectrum, the biological effects and the protection measures available, and the magnitude of the emissions and exposures produced.

'Nuclear Emergencies' summarises the types of accidents that can occur, the countermeasures that can be introduced, the standards that apply and the monitoring and detection techniques available. Emergency plans are outlined and the responsibilities of the various Government bodies listed. The National Arrangements for Incidents Involving Radioactivity are described.

'Medical Radiations' starts with a cover illustration that illustrates the caring face of radiation in medicine. It summarises the way in which x-rays are used, how staff are protected, how x-rays help in diagnosis, how patients are protected, how radioactive materials are used in diagnosis, and how radiotherapy is used; it also describes magnetic resonance imaging and summarises the role of NRPB. The bar charts are based on various NRPB studies^{(1),(4),(5)}.

Although not in exactly the same mould, the 'Radiation Atlas of Western Europe' (published 1992) is an atlas of natural radiation levels - cosmic, indoor gamma, outdoor gamma and radon. It contains maps derived from a report⁽⁶⁾ prepared by NRPB for the CEC from data produced by various researchers in western Europe. Others in the series are in production.

'RADIATION AT WORK' SERIES

A broadsheet, 'Low Specific Activity Scale in the Oil Industry', has been produced. It is intended for workers in the industry and deals with the problem of 'LSA scale' which collects in parts of oil installations. The new publication is the first in a new series dealing with the problems of radiation at work, and was suggested by staff of an oil company who had seen some of the NRPB's 'At-a-Glance' series.

The publication describes the hazards of LSA scale, shows how it can be detected and measured, and indicates the sort of precautions and procedures necessary. It also shows that radiation doses to workers close to LSA scale are much lower than doses to other workers such as industrial radiographers, nuclear industry workers and air crew. Indeed, the average off-shore worker receives a lower radiation dose than the average person in the UK because he does not inhale so much of the naturally occurring radioactive gas radon while he is on the oil rig.

One more in this series is in production and others are planned.

SLIDE SETS

The popularity of the 'At-a-Glance' series, and the requests we have had for slides based on them, has encouraged the Board to mass-produce standard sets of slides based on the series. Generally, they are supplied in batches of twenty, with a copy of the broadsheet and captions for the slides. In this way, slide sets are being produced for 'Maps and Magnitudes', 'Radon' and 'Non-Ionising Radiations' broadsheets.

GRAPHICAL TECHNIQUES AND BELIEVABILITY

A recent publication has pulled together the expertise of social scientists, scientists and public relations professionals to provide a practical guide to communicating with the public⁽¹⁾. With this publication in mind, and assuming that the science is correct, it is instructive to examine how graphics should be used to encourage people to believe scientists in this cynical age.

Firstly, the illustrations should communicate; if possible they should have impact, like the three-dimensional radon map, but that is not always possible. However, we have the data to relate a topic like radon to everyday life and this is shown in the three graphs showing how radon levels vary from season to season, from day to day, and from hour to hour as windows and doors are opened and some escapes from the house. These graphs are average values of several hundred houses and there are no false zeros - radon concentration really does vary to this degree, day to day.

The illustrations should clearly inform. Hopefully they all do - the broadsheets have been described as 'information-packed'.

The illustrations should also explain, and this they seem to do in relation to a variety of topics. They are also used to separate assumption (the linear relationship) from fact (which it is not) and they are used to show a practical item such as the ease of introducing remedial measures for radon.

The illustrations should also clarify, and an example is the 'Nuclear Emergencies' broadsheet which clarifies important, complex situations.

The illustrations should also tell the truth, as far as that can be determined, and a particularly good example is the 'Transport of Radioactive Materials' broadsheet; the charts on accidents hide nothing.

The illustrations should also compare like with like, for instance the pie diagrams in 'Maps and Magnitudes', or the bar charts of doses to workers in that publication and in 'Medical Radiation'.

All of this is important for the 'believability' of the broadsheets.

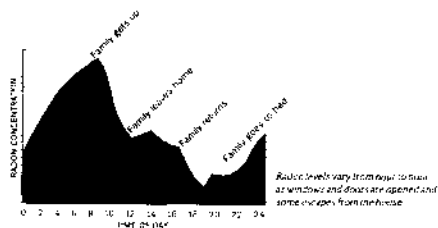
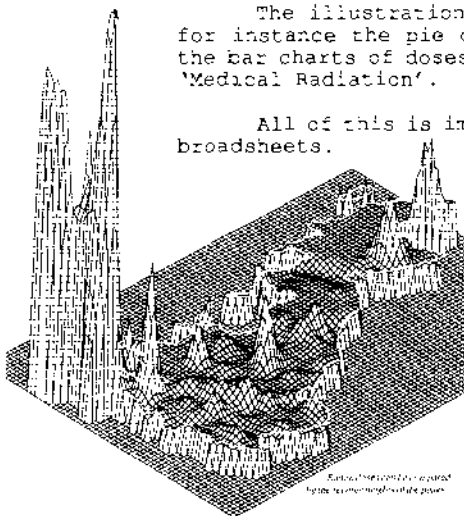

From 'Radon'

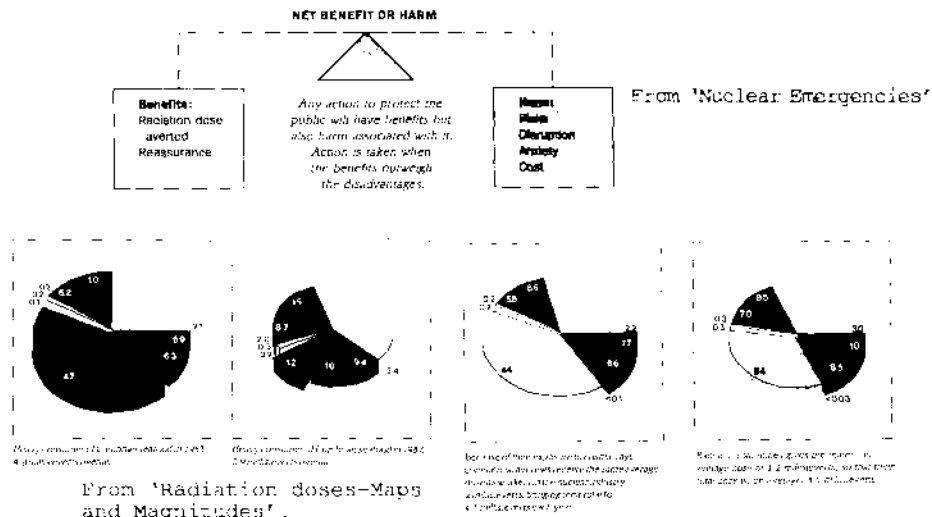

Have they been successful? The public takes into account many factors in relation to risks. For instance it is less concerned about those that are familiar and understood; and it is also less concerned when the institution is responsible for controlling the risk is seen as trustworthy. Scientists as a group are held in high regard and clear explanations are appreciated. In using the At-a-Glance series to explain radiation protection NRPB hopes it has helped the public to become at least interested and informed, and possibly enabled it to form its own opinion. The demand for the broadsheets - 50% of them have been sold to local authorities, nuclear industries, research institutes, etc, and the feedback that we have had from them and other organisations, schools, health authorities, regulatory bodies and the general public - indicates some success; but we continue to learn and we will continue to improve the series.

REFERENCES

- 1 J S Hughes, K B Shaw and M C O'Riordan, 1989, Radiation Exposure of the UK Population - 1988 Review, NRPB-R227, National Radiological Protection Board, HMSO, London.
- 2 R Golger, et al, 1984, Radiation Exposure from the Normal Transport of Radioactive Materials within the UK, NRPB-R155, National Radiological Protection Board, HMSO, London.
- 3 K B Shaw, J S Hughes, and C K Wilson, 1990, The Radiological Impact of Transport Accidents, Nuclear Energy, 29, pp 409-412.
- 4 P C Shrimpton, et al, 1986, A National Survey of Doses to Patients Undergoing a Selection of Routine X-ray Examinations in English Hospitals, NRPB-R200, NRPB, HMSO, London.
- 5 P C Shrimpton and B F Wall, 1986, Doses to Patients from Medical Radiological Examinations in Great Britain, Radiological Protection Bulletin, No 77, pp 10-14.
- 6 B M R Green, J S Hughes and P R Lomas, 1991, Radiation Atlas - Natural Sources of Ionising Radiation in Europe, Commission of the European Communities, Luxembourg.
- 7 NEA/OECD, 1991, Communicating with the Public, OECD, Paris (in French and English).

CRITERIA FOR THE COMPENSATION OF RADIATION INDUCED
HEALTH DISORDERS IN CZECHOSLOVAKIA

V. Klener, + J. Ševc, V. Plaček¹

Centre of Radiation Hygiene
Institute of Hygiene and Epidemiology, Prague
Institute of Occupational Hygiene in Uranium Industry, Píbram¹

ABSTRACT

Radiation-induced health disorders and specifically lung cancer due to radioactive substances are included in the enumerative list of occupational diseases in Czechoslovakia. A compensation for the deterministic effect is based on the evidence that the threshold dose in target organ was exceeded. For the judgment on the compensation for cancer the calculation of the causation probability is adopted as a helpful tool. It is shown on the example of lung cancer in uranium miners how the criteria changed during decades depending on new biological and epidemiological data.

INTRODUCTION

According to Czechoslovak laws only such health disorders can be compensated which are included in the official list of occupational diseases. Two items of this list are related to radiation effects, namely the lung cancer due to inhalation of radioactive substances and another rather broadly defined affection: radiation induced health disorder. Compensation in Czechoslovakia is administratively based on the certificate issued by a regional clinic (department) of occupational medicine, while the evaluation of working conditions is carried out by an officer of national hygienic service.

DETERMINISTIC EFFECTS

The criteria for granting the status of an occupational disease and a compensation can be rather clearly defined for the deterministic type of health disorders as e.g. the cataract of the eye or chronic radiation dermatitis, which from time to time are claimed for as a conjunctural results of previous occupational exposure. If an authorized expert can give evidence that under specific working conditions of the claimant the threshold dose in the target organ could have been reached, then the status of an occupational disease could be sanctioned.

STOCHASTIC EFFECTS

Quite different approach should be applied in litigations for malignant diseases in radiation workers. In Czechoslovakia we gained a longlasting

experience with lung cancers in uranium miners. In the review of Ševc et.al. (1988) 484 lung cancers were found within a well defined cohort of about 4000 miners exposed to high levels of radon daughter products between 1948-1957 and followed up systematically up to now. From the sixties many claims for compensation for lung cancer began to be submitted for expert judgement each year and the setting of unified criteria became urgent. In the course of years the approach to the assessment of a possible relationship between lung cancer and working conditions changed and the history of this development seems to be rather illustrative.

The recommended criteria for granting a compensation were first agreed upon on a seminary of experts in occupational medicine in 1961 and were based on the duration of work in uranium mines. The condition for qualifying a lung cancer as an occupational disease set at four years of underground work was derived empirically from the results of a pilot study evaluating in retrospective the causes of death in earlier miners from the area of Joachimstal within 1918-1938. In this group of miners the shortest exposure period of eight years was found, and using the arbitrary safety coefficient of two the four-year minimum exposure was settled.

In the middle of sixties a substantial reconstruction of ventilation systems in uranium mines was started and the concentrations of radon daughters decreased systematically during the following years. It appeared that the criterion bound to the duration of exposure does not mean a comparable additional risk to workers exposed in different calendar periods. It became apparent that a new criterion bound to cumulative exposure should be looked for. This idea was connected with the fact that in these times a new registration system of individual exposures of uranium workers was introduced. On the basis of this registration system the individual cumulative exposure to radon daughters in working level month (WLM) units could be identified together with the external gamma doses and served as a source for the assessment of exposure. In this period of time it seemed to be appropriate to determine, from epidemiological data, such a level of cumulative exposure below which the incidence of lung cancer was not significantly different from the spontaneous one. Such analysis resulted first in a tentative criterion of 100 WLM of cumulative exposure, later 25 WLM. The latter value reflected the findings in the youngest age group as to the start of work in uranium industry.

Another approach was adopted in the transient period in the late sixties, when the maximum yearly exposure was limited to 3 WLM and when the cumulative exposure of uranium miners began to decrease. In this situation a worker could hardly reach the critical value of 25 WLM. With the idea to mitigate the decreasing chance for compensation a combined criterion was introduced taking into account both the WLMs and the duration of underground work. A scoring system was implemented where the points for exposure (one point for each 3 WLM) and the points for the period of work (one point for one year) were summed up. Depending on the age, the critical values of the score for granting compensation were 11, 14 and 16 points for the ages up to 40, 41-50 and above 50 respectively.

In the course of eighties many new quantitative data on dose-effect relationship for radiation-induced lung cancer were collected leading to the calculation of absolute and relative risk coefficients. Thus a way has been opened for probabilistic approach in litigations for malignant diseases. We tried to follow this way, but at first we could not find any partner for the discussion on this matter. On the international scale this topic appeared first in 1983 at the 7. International Congress of Radiation Research in Amsterdam (Bond, V.P., Jablon, S., Catlin, P.J.). In the meantime the U.S. experts elaborated very valuable radioepidemiological tables (Rall, J.E., 1985) commented in the publication of an Oversight Committee (Mosteller, F., 1984).

In the Czech Republic a new procedure of eligibility for compensation was adopted which uses the new data from Czechoslovak epidemiological studies, and is based on probabilistic approach (Ševc et. al. 1989). The granting of social privileges connected with occupational disease is based on the estimate of causation probabilities given by the formula

$$PC = \frac{R}{O + R} ,$$

where R is the relative risk of cancer induction, O the spontaneous risk (O=100%). For the calculation of PC age-related relative risk coefficients are used which resulted from the epidemiological data. Three values of the relative risk coefficient are used as follows:

- age at start of work up to 29 years 5.7% per 1 WLM
- 30-39 years 3.5% per 1 WLM
- 40 y and above.. 2.1% per 1 WLM

The value of R for input into the formula is calculated as a multiple from these relative risk coefficients and the data of individual exposure in WLM. In accord with the findings of many epidemiological studies the registered cumulative exposure is lagged as follows: the exposure accumulated during the last five years before the manifestation of a cancer is omitted, and for the exposures received earlier than 15 years ago only a half of the registered value is taken in the calculation. The calculated value of PC is used as a criterion for granting compensation. With the value of $PC > 0.5$ the compensation is unequivocally allocated. In the range of $0.4 < PC < 0.5$ some supporting factors, such as the duration of underground work or the violation of the safety rules from the part of the organization, can qualify the worker for compensation. The claimants not reaching the value of $PC = 0.4$ are excluded from the benefits connected with the status of an occupational disease. This approach is applied not only to the uranium workers, but also to the workers in non-uranium mines with high concentrations of radon daughters in the air.

We are aware of that a perfect and fully just system could not be developed for the social security of workers suffering from occupational induced cancer. Our review should document how the approaches changed during the time in the effort to found an optimized way reflecting the new radiobiological and epidemiological data. In principle we use a similar, i.e. probabilistic, approach for the analysis of other types of cancer submitted for expert judgement as occupational diseases.

REFERENCES

1. Ševc J., Kunz E., Tomášek L., 1988
Cancer in man after exposure to Rn daughters
Health Physics, Vol. 54, pp. 27-46
2. Bond V.P., 1983
Radiation Exposure and Cancer: the Probability of Causation.
In: Proceedings the 7th International Congress of Radiation Research,
Amsterdam July 3-8, 1983, Session C, Somatic and Genetic Effects, C
8-16. Martinus Nijhoff Publishers, Amsterdam.
3. Mosteller F., ed., 1984
Assigned Share for Radiation as a Cause of Cancer. Oversight Committee
on Radioepidemiologic Tables. Review of Radioepidemiologic Tables
Assigning Probabilities of Causation. National Academy Press,
Washington, D.C.
4. Rall J.E., ed., 1985
Report of the National Institutes of Health ad hoc Working Group to
Develop Radioepidemiological Tables. NIH Publication No 85-2748, U.S.
Department of Health and Human Services, Government Printing Office,
Washington, D.C.
5. Ševc J., Klener V., Plaček V., 1989
The expertise of lung cancer as an occupational disease (in Czech),
Pracov. Léč., 41, pp. 423-425.

PERCEPTION DU NUCLEAIRE ET COMMUNICATION.

Alain MOREAU

Assistant Communication.
Direction du Centre d'Etudes de Saclay.
CEA - FRANCE.

NUCLEAR PERCEPTION AND COMMUNICATION.

Summary : There are three types of interrogation in nuclear communication.

The first type concerns hygiene : "what risks are you making me run ?"

The second concerns the perception of research and industrial activities, which corresponds to the categories : **Mystery, Magic, Power**, expressed in the following way : "You are mysterious", "aren't you sorcerer's apprentices ?", "You decide everything, you are party and judge".

The third concerns the choice of society in Nuclear Energy.

In all of this, technical reasoning alone is insufficient. It's the way it's done that counts. It's the way of **listening**. Our tools of communication must be forged with this in view.

La communication dans le domaine du risque radiologique est réputée difficile.

Elle est pourtant essentielle, en situation normale pour aborder le domaine de la perception du risque et celui des comportements, et, en situation de crise, pour éviter les phénomènes de rumeur ou de panique.

La communication est un véritable outil de sécurité.

Dans ce domaine, l'accident de Tchernobyl a été une leçon en France. L'impression majoritaire dans la population a été de ne pas avoir été informée, bien que les données concernant les niveaux de retombées aient été fournies.

En avril 1987, le Premier Ministre du Gouvernement français a énoncé le principe de "la transparence de l'information sur la radioactivité dans l'environnement" en soulignant que "toute l'information en ce domaine doit être accessible".

Mais c'est la façon avec laquelle nous communiquons, l'attitude que nous adoptons dans les relations que nous établissons avec le public qui sont à préciser et qui ont conduit à des réflexions ainsi qu'à des orientations au CEA et au Centre de Saclay.

COMMUNICATION ET INFORMATION

Communiquer et informer constituent deux démarches différentes. Etymologiquement, communiquer, c'est "rendre commun" : cela suppose un échange, lors d'une mise en relation ; informer, en revanche, est une démarche unidirectionnelle qui ne suppose pas de retour.

Nous avons, en général, de bons outils d'information : plaquettes, journaux, expositions, émissions de télévision... et cela est indispensable.

Mais nous sommes moins préparés pour les échanges que suppose la communication.

Très souvent, devant les difficultés, nous nous limitons à la question "Comment faire pour que le public nous comprenne ?" "Comment faire pour qu'il nous écoute ?" "Comment faire pour passer notre message ?"

Mais nous-mêmes, sommes-nous prêts à écouter ? à recevoir le message ? à comprendre ?

L'**attitude d'écoute** est d'autant plus importante dans le domaine de la perception du risque radiologique que nous quittons le domaine de la technique, de l'objectif et du rationnel, pour entrer dans celui de l'**émotion** et de l'affectif. Fondamentalement, nos interlocuteurs n'ont pas tant besoin d'acquérir des connaissances, des données, des chiffres, que d'être déchargés, débarrassés des tensions qu'ils peuvent ressentir, centrées sur l'émotion fondamentale qui est la peur.

Même si cette émotion est objectivement injustifiée de notre point de vue, elle n'en est pas moins présente avec ses raisons d'être, et il nous faut l'accepter et la reconnaître.

L'état de tension, l'état émotionnel entraînent le besoin de s'exprimer, d'être écouté. C'est l'expression, c'est-à-dire donc, **notre** écoute, qui permet la détente, condition d'une vision plus juste de la situation et d'une perception du risque plus équilibrée.

LES THEMES D'ECHANGES

Au CEA Saclay, l'expérience nous a montré que les échanges en sécurité radiologique, dans une situation relationnelle avec le public, se rapportaient à trois grandes familles d'interrogations :

Le premier niveau d'interrogations, le plus immédiatement abordé, se rapporte aux questions sanitaires : "Quels risques me faites-vous encourir ?"

Le second niveau se rapporte à la perception des activités de recherche et des activités industrielles du nucléaire. Cette perception est marquée par les catégories : **Mystère, Magie, Pouvoir**, qui s'expriment respectivement sous les formes suivantes : "Vous êtes mystérieux". "N'êtes-vous pas des apprentis sorciers ?". "Vous décidez de tout, vous êtes juge et partie."

Le troisième niveau concerne le "choix de société" sur le thème de l'énergie nucléaire.

Le premier niveau est le niveau "prise de contact" et doit, bien évidemment, être traité. Il doit conduire à l'apport d'informations sur le risque radiologique, sans chercher à convaincre, à rassurer à tout prix.

Il est indispensable de traiter le second niveau, même s'il paraît nous éloigner des sujets sanitaires. Nous le faisons surtout par le choix de notre attitude : des affirmations péremptoires, des certitudes assénées, une certaine exaltation de réalisations techniques peuvent induire, par réaction, le doute et, sinon la méfiance, du moins la réserve ainsi qu'un sentiment d'un monde différent et mystérieux.

Le troisième niveau, celui du choix du Nucléaire, nous dépasse en tant qu'experts puisqu'il concerne le citoyen, mais il nous faut garder à la conscience que cette question demeure présente.

DES OUTILS DE COMMUNICATION

C'est dans une logique d'écoute concernant ces familles d'interrogations qu'ont été réalisés des montages vidéo relatifs à la perception du risque, la protection de l'environnement, les plans de crise et les déchets nucléaires.

La parole est donnée aux habitants voisins, à nos partenaires administratifs, aux organisations écologistes ... Ce n'est pas seulement le CEA qui parle.

Ces outils sont faits pour aider aux échanges dans les réunions, pour jouer un rôle débridant en levant les inhibitions, en nous présentant prêts à recevoir toutes les remarques, y compris les remarques désagréables ou mettant en cause notre point de vue.

L'attitude d'écoute peut être symbolisée par le schéma ci-dessous :



A

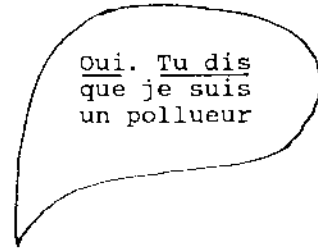

B

Il ne s'agit pas d'approuver forcément les propos de l'interlocuteur, mais de lui montrer que son point de vue est pris en considération au même titre que le nôtre.

C'est l'attitude indispensable pour créer l'**indispensable climat de confiance et être, à son tour, écouté.**

BIBLIOGRAPHIE

1. CARL R. ROGERS - Le développement de la personne - DUNOD
2. MOREAU A.
"La perception du nucléaire. La communication entre les initiés et les profanes."
Revue générale du Nucléaire - 1990 - N° 3 - Mai-Juin.
3. Montages vidéo de communication, élaborés par le CEA :
"A l'écoute de nos voisins"
"Saclay et son environnement"
"Les plans en cas d'accident"
"Les déchets radioactifs".

MORE HANDBOOKS OF TISSUE DOSES IN DIAGNOSTIC RADIOLOGY

M. Rosenstein¹, O.H. Suleiman¹, R.L. Burkhart¹
and G. Williams²

¹Center for Devices and Radiological Health, FDA
Rockville, Maryland (USA)

²Medical College of Ohio
Toledo, Ohio (USA)

ABSTRACT

An additional handbook for determining tissue doses from the upper gastrointestinal (GI) fluoroscopy examination is now available and a similar handbook addressing computed tomography (CT) examinations is being developed. Also, a complete recomputation of tissue-air-ratios is underway for revising the handbook currently available for common radiographic projections. All three efforts utilize a Monte Carlo radiation transport code and current anthropomorphic reference adult male and female phantoms.

COMPLETED HANDBOOK ON UPPER GI FLUOROSCOPY EXAMINATION

The handbook of tissue doses for the upper gastrointestinal fluoroscopic examination contains data for a set of discrete x-ray fields that can be used to simulate a dynamic upper GI examination. The handbook presents the absorbed dose to various tissues per unit entrance exposure (free-in-air) as a function of the x-ray fields and x-ray beam qualities typically used for the upper GI examination with BaSO₄ contrast material in the GI tract.

The dynamic upper GI fluoroscopic examination can be approximated with a set of discrete x-ray fields (1). The protocol for this involved videotaping the examination, while fluoroscopic technique factors, tube current and tube potential were simultaneously recorded on the audio track of the videotape. Subsequent analysis allowed the dynamic examination to be segmented into a series of discrete x-ray fields uniquely defined by field size, projection, and anatomical region. The anatomical regions associated with the upper GI examination were observed to be the upper, middle and lower esophagus, the gastroesophageal junction, the stomach, and the duodenum. The projections associated with each anatomical region are the left posterior oblique (LPO) and the right anterior oblique (RAO).

Once the discrete x-ray fields were identified, the technical specifications of each field could be used with mathematical anthropomorphic phantoms and a Monte Carlo radiation transport code to obtain tables of conversion factors (i.e. tissues doses per unit of entrance exposure, free-in-air). These phantoms and codes have evolved for use in medical x-ray dosimetry over a number of years. The conversion factors can then be used to estimate tissue doses for upper GI fluoroscopy.

The mathematical phantom used to represent the reference male patient was the ADAM phantom, developed at the Gesellschaft für Strahlen-und Umweltforschung (GSF) (2) by modification of the original MIRD-5 phantom of the Internal Radiation Dose Committee (3). The reference female patient was represented by GSF's EVA phantom (2).

Each table contains entries for male and female reference patients, giving the selected tissue doses per unit of entrance exposure, free-in-air. The values tabulated are for the average absorbed dose in the tissue (weighted over its entire mass). The user must take into consideration the actual entrance exposure at a give facility to estimate the absorbed dose for that facility.

An example of the type of data in the handbook is given in Table 1 for the duodenum anatomical region, LPO projection.

Table 1. Duodenum, LPO - tissue dose (mGy) per 1 mC/kg entrance exposure, free-in-air

Description of projection: The patient is oriented with the back to the x-ray table, the left posterior side against the table, angled at a nominal 30 degrees from a true posterior-anterior central ray. The distinguishing characteristic of the anatomical region is that it is centered on the duodenum. Field size: 11.4 cm x 11.4 cm at the image receptor. SID = 80 cm; SSD = 50 cm.

Note: Data entries apply to both single and double barium contrast procedures.

kVp	80		100		120	
HVL(mm Al)	4.0		5.0		5.5	
Tissue	Male	Female	Male	Female	Male	Female
Thyroid	+	+	+	+	-	+
Esophagus	0.02	0.02	0.04	0.03	0.04	0.03
Breast		+		0.02		0.02
Lung	0.02	0.02	0.03	0.03	0.04	0.03
Active Bone						
Marrow	0.63	0.81	0.82	1.01	0.90	1.09
Stomach	0.13	0.17	0.19	0.22	0.21	0.23
Colon	0.24	0.31	0.32	0.43	0.38	0.47
Bladder	0.01	+	0.02	0.01	0.02	0.01
Liver	0.18	0.27	0.25	0.39	0.30	0.43
Testis	+		+		+	
Uterus		0.04		0.06		0.06
Ovary		0.04		0.05		0.06
Trunk	0.35	0.34	0.39	0.39	0.43	0.43

+ Less than 0.01 mGy per mC/kg.

The tissues for which data are tabulated are those for which the International Commission on Radiological Protection (ICRP) has provided risk coefficients for cancer mortality, genetic effects and in utero effects (4). For both the male and female patient these include: thyroid, esophagus, lung, active bone marrow, stomach, colon, bladder, liver and trunk tissue. The average absorbed dose in the trunk tissue is used as an indicator for the other tissues in the trunk of the body not specifically named. Trunk tissue excludes the lungs and skeletal tissues in the trunk. In addition, testis tissue is included for the male patient, and breast, uterus and ovary tissues are included for the female patient. The average absorbed dose in the uterus is used as the absorbed dose in the embryo, and is strictly applicable only in the first two months of pregnancy.

Data are given for the following three kVp and HVL combinations: 80 kVp, 4.0 mm Al HVL; 100 kVp, 5.0 mm Al HVL; 120 kVp, 5.5 mm Al HVL.

PLANNED HANDBOOK ON COMPUTED TOMOGRAPHY EXAMINATIONS

The handbook of tissue doses in computed tomography will contain data for the range of CT examinations observed in practice. The phantoms will be adapted to the geometrical and radiation exposure complexities of CT examinations. The handbook will present the absorbed dose to tissues from CT examinations per unit of computed tomography dose index (CTDI), a measurement manufacturers are required to provide to clinical users under the United States federal performance standard for CT equipment (5).

First, absorbed doses to tissues per unit CTDI will be calculated for contiguous one-centimeter slices of both the male (ADAM) and the female (EVA) phantoms, from the apex of the head to the base of the torso. (i.e. 24 head slices and 70 torso slices). The data will encompass kVp and filtration conditions that cover the range of design for current CT systems.

From the basic set of data for the contiguous one-centimeter slices, tissues doses per unit of CTDI will be computed and presented for specific head and body CT examinations, by accumulating the tissue doses from the required slices for each examination. The handbook user will be able to select the relevant values from the handbook and apply the values of CTDI provided by the CT system manufacturer or determined locally to obtain tissue doses for the examination.

UPDATE OF HANDBOOK ON COMMON PROJECTIONS IN DIAGNOSTIC RADIOLOGY

The revised handbook of selected tissue doses for common projections in diagnostic radiology will contain a complete and expanded recomputation of the data published in December 1988 (6). The expansion will consist of separate entries for a reference adult male and a reference adult female patient, additional oblique projections, an expanded list of tissues, and reformulation of a radiation detriment index.

Approximately 17,700 separate computer runs are underway. Tissue-air-ratios will be generated for appropriate tissues in each of two phantoms. The anticipated computer runs include: up to 8 different clinical projections (i.e. PA, LPO, LL, LAO, AP, RAO, RL, RPO) for each phantom; 160 to 320 4 cm x 4 cm plane parallel beams (grids) per clinical projection; and 4 to 7 monoenergetic energies per grid.

The expanded set of tissue-air-ratios will permit a much greater range of clinical conditions to be addressed than previously available, and the expanded set of tissue-air-ratios will be incorporated into the computer program for tissue doses in diagnostic radiology (7) now widely distributed and in use throughout the world.

REFERENCES

1. Suleiman, O.H., J. Anderson, B. Jones, G.U.V. Rao and M. Rosenstein. Tissue doses in the upper gastrointestinal fluoroscopy examination. Radiology, 178:653 (1991).
2. Kramer, R., M. Zankl, G. Williams and G. Drexler. The calculation of dose from external photon exposures using reference human phantoms and Monte Carlo methods. Part I: The male (Adam) and female (Eva) adult mathematical phantoms. GSF-Bericht-S-885. Gesellschaft für Strahlen- und Umweltforschung mbH, München (1982).
3. Snyder, W.S., M.R. Ford, G.G. Warner, and H.L. Fisher, Jr. Estimates of absorbed fractions for monoenergetic phantom sources uniformly distributed in various organs of a heterogeneous phantom. Journal of Nuclear Medicine, Supplement Number 3, Pamphlet 5 (August 1989).
4. 1990 Recommendations of the International Commission on Radiological Protection. ICRP Publication 60. Annals of the ICRP, Volume 21, No. 1-3. Pergamon Press, Oxford (1991).
5. Food and Drug Administration, 21 CFR Part 1020, Diagnostic x-ray systems and their major components; amendments to performance standard; Final rule, Federal Register 49: 34698-34714 (1984).
6. Rosenstein, M. Handbook of selected tissue doses for projections common in diagnostic radiology. HHS Publication (FDA) 89-8031, Food and Drug Administration, Rockville, Maryland (1988).
7. Peterson, L.E. and M. Rosenstein, Computer program for tissue doses in diagnostic radiology (for VAX and IBM-compatible PC systems). Food and Drug Administration, Rockville, Maryland (1989).

RADIOLOGICAL IMPACT OF DIAGNOSTIC NUCLEAR MEDICINE TECHNOLOGY
ON THE QUÉBEC POPULATION (PATIENTS AND WORKERS) IN 1989.

L. Renaud, J. Blanchette
Institut de Cardiologie de Montréal, Hôpital Laval de Québec,
Québec, Canada.

ABSTRACT

Using the results of a six month survey on the doses received by non-monitored hospital workers from diagnostic nuclear medicine patients (DNMP) in three hospitals and published statistics on Québec's workers and hospitals, an evaluation of the radiological impact of DNMP has been calculated on the Québec's population. In 1989, diagnostic nuclear medicine accounted for 6 % of the diagnostic imaging acts. The diagnostic nuclear medicine gave an average of 6.4 mSv/act or a total of 2,800 Sv-man. The diagnostic nuclear medicine technologists community received 0.4 Sv-man and the non-monitored hospital workers 1.7 Sv-man from the DNMP in the same year.

INTRODUCTION

The nuclear medicine technology is a very powerful diagnostic tool. However, its use brings a new radioexposure source and environmental contamination inside the hospital. In the late eighties, according to the Québec's Ministère de la Santé et des Services Sociaux[1], the diagnostic usage of nuclear medicine was growing at a rate of 10 to 13 % per year. In 1989, this technology was available into 44 Québec's hospitals[2] and generated 440,000 nuclear medicine acts[3] paid by the Régime d'Assurance Hospitalisation du Québec (RAHQ). The diagnostic nuclear medicine patients (DNMP) are ambulatory inside the hospital and may influence the environmental radiation level.

In this study, we estimate the monitored and non-monitored hospital workers collective dose in hospital environment from DNMP as well as the effective dose per nuclear medicine act in 1989 using three major sources of information: a survey[4] designed to measure and assess the radiological impact of DNMP on a selected group of non-monitored hospital workers, published[5] occupational doses in Québec and various statistics available on Canadian hospitals[2,6].

MATERIAL AND METHODS

A survey over 10 consecutive weekdays in three university hospitals (ICM: Institut de cardiologie de Montréal (171 beds), LAVAL: Hôpital Laval de Québec (340 beds), HDM: Hôtel-Dieu de Montréal (430 active beds)) succeeds to demonstrate that the nuclear medicine patients are highly ambulatory inside the hospital. Few minutes after their radioactive administration (RA), both in-patients and out-patients can go anywhere inside the hospital[4]. More than eighty-three percent (83%) of the patient movements occur in the first 24 hours. This time and motion study enabled us to identify hospital non-monitored groups (nurses, physicians, technologist, cleaners, secretary) who were likely to come regularly in the near environment of the DNMP.

Following this survey, we distributed 840 calibrated thermoluminescent² dosimeters (TLD) to selected workers in the three participating hospitals. Table I summarizes the distribution profile of TLD's holders in each hospital. TLD were worn during 6 consecutive months.

¹ This work was produced under contract to the Atomic Control Board and Supply and Services Canada; contract No. 87015-8-4099/01-55, project 6.105.1.

² Chalk River Nuclear Laboratories, Chalk River, Ontario, Canada, K0J 1P0

Concurrently, all RA were recorded: prescribed procedure, radioactivity administered, isotope, radiopharmaceutical, patient origin (in or outside hospital), date and hour of the RA.

RESULTS

Exposure to the patients

Table II summarizes the mean RA (MBq) per procedure for various nuclear medicine examinations and the average number of RA per week. During this six month survey which has recorded over 10,000 RA, we observed a large variation in RA between hospitals depending upon their activities and specialities.

The effective dose per unit of activity for normal adults [7,8,9] combined with the observed activity per RA and with the medical acts paid by RAHQ in 1989, leads to an overall estimate of 2800 Sv-man to the Québec's population by the diagnostic nuclear medicine technology or an average of 9.8 mSv for each of the 268,000 RA or 6.4 mSv per act. Table III summarizes the number of RA for each group of nuclear medicine procedures with the corresponding collective and individual effective dose (H_E). 75 % of nuclear medicine imaging devices is clustered in Montréal (55 %) and Québec (21 %) areas.

Exposure to the non-monitored workers

From the 840 distributed TLD, 805 were returned for reading and report. Table IV summarizes the statistics on exposures of surveyed personnel and the surveyed fraction of the whole hospital personnel. The average value of this fraction was sixteen (16) percent.

Merging the average of the annual occupational doses given in Table IV, with published statistics [2,6] on the hospitals with a nuclear medicine service, we then estimate a collective dose of 1.7 Sv-man to the non-monitored hospital workers population coming in the near environment of the DNMP. This estimate assumes that only 16 % of the workers might be exposed to the diagnostic nuclear medicine patients, a very conservative hypothesis.

Exposure to the diagnostic nuclear medicine technologists

As published by Sont and al. [5], the average body dose (including all doses) to the nuclear medicine technologist was 2.35 mSv in the province of Québec during 1988. We assume that the average dose to those workers remained the same during 1989. In 1989, the province of Québec had 170 registered nuclear medicine technologists leading to a collective dose of 0.4 Sv-man.

Table I: Distribution of analysed TLD in each participating hospital.

WORKERS	ICM	LAVAL	HDM
Nurses	111	199	168
Physiotherapists	5	-	-
Inhalo therapists	8	25	33
Ordentics	24	17	61
Porters	3	12	9
Ultrasound tech.	3	4	5
Ultrasound Phys.	7	4	-
ECG Technologists	14	16	6
EEG Technologists	-	-	3
Neurophysiologists	-	-	3
Cleaners	8	17	15
Receptionists	4	7	9
Others	1	4	-
Total	188	305	312

Table II: Mean RA (MBq) and relative distribution (%) of the most frequent nuclear procedures in each hospital.

PROCEDURE	ICM	LAVAL	HDM
Bone scan	-	1110 (21)	1110 (24)
Brain Scan	-	1110 (3)	1110 (27)
Myocar. perf. (Tl^{201})	106 (24)	111 (25)	74 (9)
Myocar. perf. (Tc^{99m})	1002 (14)	-	-
Ventriculography	1313 (54)	924 (23)	1110 (5)
Liver scan	-	296 (1)	185 (6)
Lung scan	155 (1)	149 (9)	148 (5)
Thyroid I^{131}	-	(5)	(5)
Tc^{99m}	-	1.3	2.2
		260	74
All RA	920 (95)	589 (85)	842 (77)
RA/week	92	108	160

DISCUSSION

The diagnostic nuclear medicine technology gives more effective dose per act to the patients and to the monitored and non-monitored hospital workers when compared to the radiological diagnostic imaging technology. The Québec's population received about 6200 Sv [10] or approximately 1 mSv per capita per diagnostic medical irradiation in 1989 or 0.5 mSv by radiodiagnostic act and 6.4 mSv per nuclear medicine act. The nuclear medicine technology accounts for only 6% of total medical acts paid by RAHQ and generated 45% of the

Table III: Distribution of RA per organ groups and effective dose (H_p) corresponding in 1989.

	# RA	H_p (Sv)	H_p /RA (mSv)
Endocrine S.	45,722	817	17.8
Haematopoietic S.	7,129	190	26.6
Urinary S.	22,102	111	5.0
Digestive S.	24,711	85	3.4
Cardio-Vasc. S.	48,076	655	13.6
Respiratory S.	23,171	80	3.4
Nervous S.	25,491	229	8.9
Muscu. Squelet. S	72,793	593	8.1
Others	1,983	45	22.6
Total RA	286,178	2804	9.8
	ACTS		H_p /act(mSv)
Total	439829		6.4

Table IV: Statistics related to non-monitored workers.

HOSPITAL SAMPLE SIZE	OCCUPATIONAL				RANGE 6 mo (mSv)	NUMBER WORKERS	% IN SURVEY	# γ CAMERAS	NM Tech DOSE/Y (mSv)
	BKG (mSv)	MEAN DOSE/6mo (mSv)	MEAN DOSE/Y (mSv)						
ICM	191	.49 ± .02	.08 ± .02	.16 ± .04	0-1.4	1000	19	3	3.8
LAVAL	307	.51 ± .06	.06 ± .06	.12 ± .12	0-.55	1800	17	3	2.9
HDM	307	.52 ± .01	.07 ± .01	.14 ± .01	0-1.25	2163	14	7	6.4*
	805	0.50	0.07	0.13		4963	16	13	4.4

*See available returns

patient effective dose. This estimate excludes therapeutic procedures (angioplasty, I^{131} therapy), dental and chiropractor radiology and was not weighted for patient age at the irradiation time.

Sont reports that the radiological technologists are exposed at an average of 0.13 mSv/year or about 0.4 Sv-man. We have calculated a collective dose of 0.4 Sv-man to the nuclear medicine technologists. According to Table VI, this group contributes for 8 % of the collective occupational dose in Québec. These monitored workers are the most exposed workers in medical environment in the province of Québec.

Table V: Québec nuclear medicine profile in 1989.

# Hospitals:	44
# γ cameras/Hospital	2.7 ± 1.6
# workers/Hospital	1832 ± 960
# Nucl. Med. Tech.	170
Mean occupational dose of Nucl. Med. Tech.	2.35 mSv

Mobile or fixed X-Ray machines are visible and known sources of irradiation, the DNMP is *incognito* for the majority of the workers. The unknown character of this human radioactive source may explain the observable range of radiological exposures (upto 1.4 mSv/6 months) on more than 90 % of the 805 workers monitored during the six month survey. These workers had a dose detectable by the TLD technology. From those data, we conclude that on average at least 14 % (90 % x 16 %) of the hospital workers population may receive a quantifiable irradiation by the usage of the nuclear medicine technology into an hospital. We estimate that the collective dose to that personnel (nurses, orderlies, porters, cleaners, physicians...) working in this environment is 0.13 mSv per capita during 1989, a dose comparable to the one of radiological technologists. According to Sont, all

workers of Québec monitored by the dosimeters of Health and Welfare Canada share a collective dose of 5 Sv-man. According to this analysis, the non-monitored hospital workers exposed by DNMP share a collective dose of 1.7 Sv-man.

This estimate excluded the general population exposure from the DNMP. The individual estimate may be different from one hospital to another depending upon the number of nuclear medicine patients, the technology acceptance, the isotope and the activity administered, the management of the patient, the workers' duty and training.

CONCLUSION

When fully justified, the diagnostic nuclear medicine technology like any other technology using ionizing radiations has to be optimized in terms of the dose to the patient and to the workers' population. A slight decrease of the exposure rate at the origin, a better management of the radiation source or any adapted training may have a significant impact on the collective dose even if the average individual dose to the non-monitored personnel is low compared to the diagnostic nuclear medicine technologist. In the optimization process, doses to the diagnostic nuclear medicine technologists, to the patients as well as to the non-monitored hospital personnel has to be considered.

REFERENCES

1. Ministère de la santé et des services sociaux du Québec, Service de technologie biomédical. (Personnal communication). 1989
2. Moss P: Valeurs de remplacement des biens mobiliers en centre hospitalier. Conférence des Conseils régionaux de la santé et des services sociaux du Québec. (Personnal Communication), June 1990.
3. Ministère de la santé et des services sociaux du Québec. Data 1989: Régime d'assurance maladie et régime d'assurance hospitalisation du Québec. (Personnal communication), 1990.
4. Renaud, L., Blanchette, J., Galand, C., Radiation Exposure of Non-Monitored Hospital Personnel, Report prepared for the Atomic Energy Control Board, Ottawa, Canada, may 91, 55 p.
5. Sont, W.N., Wilson, J.A., Ashmore, J.P., Grogan, D., Occupational Radiation Exposures in Canada-1988, ISBN 0-662-96131-5, Health and Welfare Canada, 1990.
6. Canadian Hospital Association: Canadian Hospital directory, 1989
7. ICRP Publication 52: Protection of the patient in Nuclear Medicine. Annals of the ICRP, Volume 17, No. 4, 1987.
8. ICRP Publication 53: Radiations Dose to Patients from Nuclear Radiopharmaceuticals. Annals of the ICRP, Volume 18 No. 1-4, 1987.
9. ICRP Publication 26: Recommendations of the International Commission on Radiological Radioprotection. Annals of ICRP, Volume 1, No. 3, 1977.
10. Renaud L., Blanchette J.: The Effective Dose Equivalent by Diagnostic Medical Examinations in 1989 To Québec's Population. CRPA Twelfth annual conference 1991, Winnipeg, Canada, June 1991 (abstract).

Table VI: Individual (mSv) and collective dose (Sv-man) to monitored and non-monitored hospital workers in Québec.

	QUÉBEC
INDIVIDUAL	(mSv)
X-Ray technologist	.13
Nucl. Med. technologist	2.35
Monitored population	.24
Non-monit. population	.13
COLLECTIVE	(Sv-man)
X-ray technologists	.4
Nucl.Med. technologists	.4
Monitored population	5.0
Non-monit. population	1.7

WORLD-WIDE VARIATIONS IN EXPOSURES OF PATIENTS
TO IONISING RADIATION

Jack Valentin

Swedish Radiation Protection Institute (SSI),
Box 60204, S-104 01 Stockholm, Sweden

ABSTRACT

X-ray examinations increase in developing and nuclear medicine examinations in all countries, but all are less frequent in developing countries. Children are not infrequently examined, more so in developing countries. Doses per x-ray examination can be lower in developing countries, but nuclear medicine doses are similar in all countries.

INTRODUCTION

UNSCEAR (The United Nations Scientific Committee on the Effects of Atomic Radiation) has estimated medical exposures to 0.4-1 mSv annually per caput (1). This refers mostly to the early 1980ies, and rests on extrapolation from few countries. Access to medical radiation increases in developing countries, and the pattern of investigations changes.

Hence UNSCEAR initiated a Survey of Medical Radiation Usage and Exposures in 1989. Some 40 very differing countries have responded so far. This paper describes some aspects of the answers. The paper states the author's personal views only and does not predict any future UNSCEAR conclusions.

The Survey contained questions on national conditions and numbers of patients, their age and sex, doses or activities for diagnostic and therapeutic uses of radiation. However, this paper deals with diagnostic radiation uses only. Many countries do not have the statistics requested. Still, even the relatively few answers obtained now extend our knowledge appreciably. These answers come from all inhabited continents, developing as well as industrialised countries, and small as well as large ones.

Countries are grouped in four levels of health care, according to the frequency of physicians. 22 answers come from level I countries (<1,000 population per physician), 7 from level II (1,000-3,000), 6 from level III (3,000-10,000) and 2 from level IV (>10,000 population per physician).

RESULTS: GENERAL CONDITIONS

The Survey provides national averages and ranges of individual values for the various quantities. Here, most results are given as ranges and medians of national averages.

Some countries could not answer all questions, so entries in subsequent tables do not always represent all countries.

Table 1 shows arithmetic mean frequencies of radiologists, diagnostic x-ray units and nuclear medicine clinics. For health care levels I and II, a time trend is indicated. Access to medical radiation increases quicker at level II, but is still lower than at level I (where access may be close to satisfying demand).

Table 1. Access to medical radiation by level of health care (number per 1,000 population)

Level of health care:	I	II	III	IV
Radiologists 1970-74	0.063	0.023	-	-
1985-89	0.076	0.038	0.009	0.0003
Diagnostic x-ray units 1970-74	0.45	0.026*	-	-
1985-89	0.39	0.11*	0.037	0.004
Nuclear medicine clinics 1970-74	0.005	0.0003	-	-
1985-89	0.008	0.0009	0.0004	0

* including dental units

RESULTS: DIAGNOSTIC X-RAY EXAMINATIONS

Table 2 shows that the frequency of x-ray examinations has increased only slightly at level I, but almost doubled at lower levels. At level I, both maximum and minimum national averages are actually lower in the 1980ies, reflecting substitutions of ultrasound, endoscopy etc for x rays.

Table 2. Number of x-ray examinations per 1,000 population (range and median of national averages)

Level of health care:	I	II, III, IV
1970-74 Range	369 - 2705	<8 - 26
Median	586	17
1985-89 Range	144 - 1157	14 - 81
Median	613	29

Table 3 shows patient age distributions for some x-ray examinations. Examination of children is not very infrequent and often more common at lower levels of health care, probably due partly to young populations of developing countries.

One could expect high doses per examination in developing countries. But as Table 4 shows, no such trend was reported. National ranges of individual doses are also narrower for developing countries. If this is correct and representa-

Table 3. Patient ages for some x-ray examinations 1985-89
(national average percentages)

Level of health care:		I		II		III	
		Age:<16	>40	<16	>40	<16	>40
Chest	Range	4.6-13	49-80	7.6-32	33-43	6.0-27	28-38
	Median	6.7	63	16	38	15	34
Lumbosacral	Range	1.2-13	47-67	2.6-12	40-50	7.4-15	41-43
	Median	3.9	61	4.0	48	14	42
Upper GI tract	Range	0-5.1	56-81	2.1-10	30-47	2.0-10	44-55
	Median	1.5	67	6.1	39	9.1	52
Mammography	Range	0-1.2	49-91	0	9.9-49	0	89
	Median	0	68	0	29	0	89
Computed tomography	Range	4.5-12	49-80	4.4-6.5	37-64	-	-
	Median	6.1	64	5.5	51	-	-

tive, various causes of the lower doses are conceivable.

Table 4. Entrance surface doses for some x-ray examinations 1985-89 (national averages, mGy)

Level of health care:		I	II	III
Chest - radiography	Range	0.13 - 1.5	-	-
	Median	0.4	0.8	0.8
Lumbosacral	Range	4.2 - 30	9.8 - 27	2.8 - 4.0
	Median	22	18	3.4
Upper GI tract	Range	2.2 - 40	3.3 - 30	2.6 - 3.4
	Median	8.0	17	3.0
Mammography	Range	1.5 - 165	-	-
	Median	8.5	7.9	0.6
Computed tomography	Range	29 - 78	-	-
	Median	37	14	-

RESULTS: DIAGNOSTIC NUCLEAR MEDICINE

The frequency of all nuclear medicine examinations is

Table 5. Number of nuclear medicine examinations per 1,000 population (range and median of national averages)

Level of health care:		I	II	III	IV
1970-74	Range	3.8-14	0.04-3.8	-	-
	Median	6.2	0.5	-	-
1985-89	Range	3.5-56	0.2-2.0	-	-
	Median	13	0.9	1.0	0.09

given in Table 5. Nuclear medicine was hardly available at lower levels of health care in the early 1970ies. The examination frequency has increased with time, and in contrast to x rays, the increase is marked also at health care level I.

Patient age distributions are shown for some nuclear medicine examinations in Table 6. Again, it is not extremely rare that children are examined.

Table 6. Patient ages for some nuclear medicine examinations 1985-89 (national average percentages)

Level of health care:	I		II		III,IV		
	Age:<16	>40	<16	>40	<16	>40	
Bone	Range	0.8-45	25-91	5.1-21	40-70	-	-
	Median	3.4	76	20	44	0.3	67
Brain	Range	0-21	20-90	0-48	26-86	1.4-12	24-73
	Median	2.1	73	17	59	6.7	49
Liver/spleen	Range	0.6-8.1	40-87	1.7-5.8	43-62	0.3-1.2	40-73
	Median	1.7	76	5.6	48	0.8	57
Renal	Range	3.8-3	13-70	0-9.9	11-51	1.7-7.7	18-76
	Median	15	51	1.8	41	4.7	47
Thyroid uptake	Range	0-2.2	10-80	3.4-12	38-69	0.7-1.8	20-46
	Median	0	61	9.1	41	1.3	33

Finally, Table 7 shows some average activities in nuclear medicine examinations. No trend can be seen. Thus, the doses per examination are similar for different countries.

Table 7. Activities used in some nuclear medicine examinations 1985-89 (national averages, MBq)

Level of health care:	I		II		III,IV	
Bone Tc-99m	Range	420 - 783		182 - 740		570 - 740
	Median	614		740		555
Brain Tc-99m pertechnetate	Range	60 - 801		-		500 - 740
	Median	615		370		620
Liver/spleen Tc-99m coll	Range	75 - 196		37 - 296		74 - 111
	Median	125		204		93
Renal I-131 hippuran	Range	0.9 - 6		0.4 - 1.1		-
	Median	4.9		0.8		0.9
Thyroid I-131 uptake	Range	0.2 - 9.5		0.1 - 3.0		1.7 - 2.2
	Median	0.9		0.4		1.9

REFERENCES

1. United Nations: Sources, effects and risks of ionizing radiation. UN Sales publ E.88.IX.7. New York (1988)

AN ANALYSIS OF THE SPATIAL DOSE DISTRIBUTION
AROUND THE PATIENT WITH THERAPEUTIC DOSE OF I-131

T. Orito, *S. Koga, A. Takeuchi, M. Ishizaka, *G. Takeshita, S. Suzuki
and *H. Toyama

Department of Health Physics, School of Health Sciences,
*Department of Radiology, School of Medicine, Fujita Health
University, Toyoake, JAPAN

ABSTRACT

Spatial dose distribution curves based on the measurement of clinical cases, theoretical and experimental analyses were studied around the patients treated with I-131 for thyroid carcinoma. When the maximum activity in a patient was 555MBq, external exposure at 50cm from a side of the subject's was $76.4 \mu\text{Sv/hr}$ for theoretical value, $65 \mu\text{Sv/hr}$ for experimental value, and $32 \mu\text{Sv/hr}$ for clinical case. The total exposure at 1m from the side of the breast in clinical cases 1, 2 and 3 were obtained 7.75, 1.97 and 0.79mSv, respectively. The result of case 1 suggested that special restriction need be placed on the patient's proximity to other individual.

INTRODUCTION

When performing the treatment of various kinds of diseases using Radionuclide (RN) in the practice of nuclear medicine, the patient becomes a significant source of radiation. I-131 utilized for the RN treatment of thyroid disease is said to be only one RN presently used for therapy in Japan. The patient administered I-131 must be admitted in a RN ward. However, there are only a small number of data which can be used in investigating the criteria for permitting the patient to discharge the hospital or transferring the patient to a general ward. This time, in order to clarify these points, a theoretical analysis of the spatial dose distribution around the patient administered I-131 was conducted, a model experiment was performed and clinical examples were investigated.

MATERIAL and METHOD

The spatial dose distribution showing in Fig 1 calculated by using following formula.

n_i =means number of photons per disintegration

$$\Gamma = 0.459 \sum_i n_i E_i (\mu_{en} / \rho)_{air} \quad (\mu Gy \cdot m^2 \cdot MBq^{-1} \cdot h^{-1})$$

E_i -photon energ (MeV)

$(\mu_{en} / \rho)_{air}$: mass energy-absorption coefficient for air (m^2 / kg)

Actual measurement by phantoms was performed. The neck sections of Alderson Rand Phantoms No.7~11 were extracted and ORTNS-type neck phantoms were inserted in those areas. The measurement was performed using an ionization survey meter (Aloka TCS-151). Three clinical cases were investigated and they were administered 3.7(case 1), 3.26(case 2) and 3.3GBq of I-131 respectively. At the same time as the measurement of the spatial dose, Linear Scanning was carried out using Medical Universal Human Counter (Toshiba) in order to know the distribution of RN in the patient's body.

The spatial dose distribution within the RN ward and the RN distribution within the body were successively measured from immediately after the administration.

RESULT and DISCUSSION

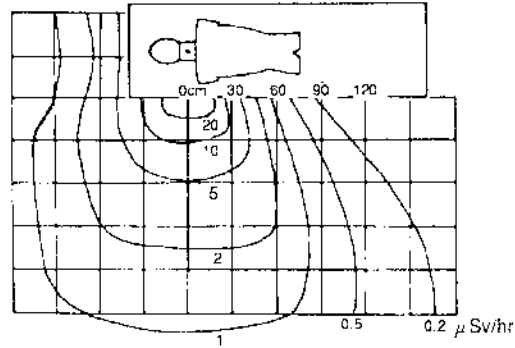

Fig. 1 Theoretical spatial dose distribution curve around the Alderson Rand Phantom under the thyroid gland containing I-131 solution of 111MBq.

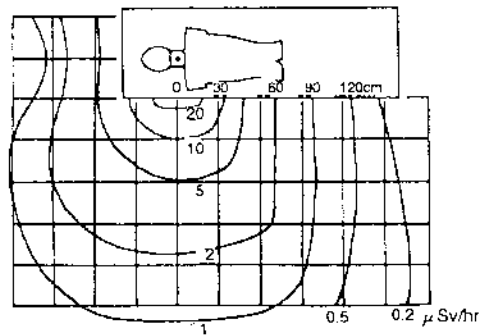

Fig. 2 Experimental spital dose distribution curve around the Alderson Rand Phantom under the thyroid gland containing I-131 solution of 111MBq.

Table 1 External exposure at 50 cm or 80 cm from a patient after ¹³¹I was administered to a patient orally.

	After 1 week		After 2 week	
	at 50cm (μ S/hr)	at 80cm (μ S/hr)	at 50cm (μ S/hr)	at 80cm (μ S/hr)
Patient 1	66.0	28.0	28.0	13.0
Patient 2	0.5	0.2		
Patient 3	2.0	1.2	0.2	0.1

Table 2 External exposure at 50 cm from the object when the maximum activity in a patient was 555MBq.

	Exposure rate at 50cm (μ S/hr)
Patient 1	36.0
Patient 2	30.0
Patient 3	30.0
Experimental value	64.5
Theoretical value	76.5

Fig 1 shows the calculated spatial dose distribution assuring 111 MBq of I-131 contained in the thyroid of the neck. Fig 2 shows the actual measurement by phantoms. According to the results of the above three cases, the external exposure levels at 50cm and 80cm from the side of the patient's body were obtained one week and two

Table 3 Total exposure at 0.5, 1.0 and 2.5 m from the side of the breast of clinical case.

	Activity administered (GBq)	Exposure per treatment		
		at 0.5m (mSv)	at 0.5m (mSv)	at 0.5m (mSv)
Patient 1	3.7	31.0	7.75	1.24
Patient 2	3.26	3.12	0.78	0.125
Patient 3	3.3	3.71	1.72	0.315

weeks after the administration and the results indicated by the table were obtained. In case 2 showing a small uptake into the thyroid and a rapid discharge, external exposure levels observed one week after the administration for 50cm distance

and 80cm distance were 0.5μ Sv/hr and 0.2μ Sv/hr respectively. In case 1 showing a retarded discharge due to transfer, external exposure levels obtained for these distance were 66μ Sv/hr and 28μ Sv/hr respectively. As for the results obtained two weeks after, they were 28μ Sv/hr and 13μ Sv/hr for these distances in case 1 which dose rates indicating almost no existence of an external exposure source were observed in case 2. The spatial dose rate for the time when the intrabody residual level of I-131 becomes 555MBq was obtained at 50cm from the side of the patient's body for each of the theoretical analysis, the model experiment and the clinical cases there by obtaining the results shown in the table 2. The time when the intrabody residual level becomes 555MBq was about 12 days after the administration for case 1, about one day after for case 2 and about 3 days after for case 3. The spatial dose rate for the clinical cases was about 1/2 of that for theo-

retical analysis and that for the model experiment. This is considered to be due to the fact that I-131 was incorporated only into the thyroid in the latter cases while I-131 was distributed in the whole body of each clinical case. Therefore, when considering the criteria for the admittance of patients administered RN in a special ward while taking into consideration the external exposure level for a person beside the patient, the external exposure level will be overestimated if the calculation is performed on the basis of the supposition that the source of radiation consisting of a point source attenuates only according to the physical half life.

Accordingly, it is necessary to perform estimation according to the result of each clinical case in order to know accurate exposure levels. Total exposure levels for persons continuously staying at 0.5, 1.0 and 2.5m from the patient from immediately after administration of I-131 were calculated and the results shown in the Table 3 were obtained.

According to the definition by I.C.R.P, it is not necessary to provide a special restriction to another person staying near the patient for the radiation level with which the yearly dose limit at 1m from the patient is less than 5mSv. Cases 2 and 3 are those corresponding to this category while a special restriction is required for case 1. It has been found that the patient should be admitted in a RN treatment ward provided with a special measure for preventing adjacent persons from being exposed to radiation by taking into account the fact that the effective half life varies according to each case.

CONCLUSION

Spatial dose distribution curves based on the measurement of clinical cases, theoretical and experimental analyses were studied around the patients treated with I-131 for thyroid carcinoma. When the maximum activity in a patient was 555 MBq, external exposure at 50cm from a side of the subject was $76.4 \mu\text{Sv/hr}$ for theoretical value, $65 \mu\text{Sv/hr}$ for experimental value and $3.2 \mu\text{Sv/hr}$ for clinical case. The total exposure at 1m from side of the breast in clinical cases 1, 2 and 3 were obtained 7.75mSv, 0.78mSv and 1.72mSv respectively. The result of case 1 suggested that special restriction need be placed on the patient's proximity to other individual.

**ABSORBED DOSE TO TECHNICIANS WORKING AT ACCELERATORS FOR
RADIATION THERAPY**

A. Almén, L. Ahlgren and S. Mattsson
Department of Radiation Physics Malmö
University of Lund
Malmö Allmänna Sjukhus
S-214 01 MALMÖ

ABSTRACT

Absorbed dose to the trunk and the hands of technicians working at high-energy accelerators for radiotherapy have been measured for seven accelerator in different hospitals. Induced radioactivity and leakage radiation have been studied. The annual absorbed dose to the trunk was estimated to 2.0 mGy. Induced radioactivity contributed with 1/3 of the total absorbed dose. For one accelerator the variation of absorbed dose rate after an irradiation inside the treatment room was followed. Radionuclides with rather long halflives e.g. ^{187}W were identified.

INTRODUCTION

External radiotherapy is mainly carried out with photon or electron beams from electron accelerators. The technicians operating these accelerators will be irradiated from photons penetrating the radiation shield in the accelerator head and the walls of the treatment room. Photons scattered in the patient and in the treatment room before penetration of the walls will also contribute. If the photon energy exceeds 8-10 MeV the technicians when inside the treatment room will be irradiated by induced radioactivity produced by photonuclear reactions. The highest induced activity is expected in the parts of the accelerator exposed by the highest photon fluence. Depending on the photon energy and irradiated material a number of radionuclides will be produced with different halflives. Neutrons will also be produced.

The aim of this study was to estimate the absorbed dose to technicians working at accelerators producing high-energy photons due to induced radioactivity and leakage radiation.

MATERIALS AND METHODS

Absorbed dose to 24 technicians working at seven high energy accelerators in six different hospitals in Sweden was measured. The accelerators used accelerating potentials above 10 MV producing photon and electron beams of different energies.

Five TL-dosimeters (LiF, $3.2 \times 3.2 \times 0.9 \text{ mm}^3$) were carried on the trunk and five on a wrist bracelet. The dosimeters on the trunk were covered with 5 mm buildup material, the dosimeters on the wrist had no additional buildup except a thin plastic cover. The dosimeters were calibrated in a ^{60}Co -field. During the measuring period of ten working days the background radiation and the radiation at the control console was measured with TL-dosimeters. A pressurized ionisation chamber (Victoreen 450P) was also used to measure the absorbed dose rate due to leakage and scattered radiation at the control console when high-energy

photons were used. The leakage radiation inside the treatment room was measured with a ionizing chamber one meter from the isocenter perpendicular to the central beam axis. For the measurements a 50 mm buildup cap was used.

The time variation of the absorbed dose rate due to induced activity after a treatment with high-energy photons in one treatment room was measured with a NaI(Tl)-detector placed at the isocenter and at 1.3 m above the floor at a location beside the treatment couch. The measurement was carried out for one accelerator and started 0.5 min after the irradiation and went on for 48 h. The signal from the NaI(Tl)-detector was compared with readings from a plastic scintillation detector calibrated for absorbed dose measurements. The curves over count-rate versus time were analyzed and separated into several exponential functions.

RESULTS AND DISCUSSION

Absorbed dose rate outside the treatment room due to leakage radiation during a treatment with high-energy photons varied considerably between the accelerators (Table 1). Table 1 also shows the leakage radiation through the accelerator head in the treatment room. The leakage radiation is given per absorbed dose unit given to the patient. Inside the treatment room the average absorbed dose measured divided by absorbed dose maximum in water at isocenter is given in table 1.

Table 1. Leakage radiation inside the treatment room and at the control console, when irradiating with high-energy photons.

Designation	Manufacturer	Leak. rad. inside/ mGy/Gy	Leak. rad. control console/ μ Gy/h
Linac 1	Clinac 1800 Varian	0.134	4.4
Linac 2	SL 75/20 Philips	0.135	0.4
Linac 3	SL 75/20 Philips	0.347	1.0
Linac 4	Dynaray LA20 Brown Boveri	0.435	1.2
Linac 5	SL 25/20 Philips	0.459	0.2
Microtron 1	MM22 Scanditronix	0.513	1.4
Microtron 2 Race trac	MM50 Scanditronix	0.462	2.5

The annual dose was calculated by extrapolating the measured dose to one year assuming a workload of 45 week in a year. The natural background was subtracted from the TL-readings. The absorbed dose at the control console was calculated and was subtracted from the total absorbed dose. Estimation of the

contribution from induced radioactivity to the total absorbed dose was then obtained. The average absorbed dose to the trunk was estimated to 2.0 mGy per year. In figure 1 the mean absorbed dose to the technicians at each accelerator are given.

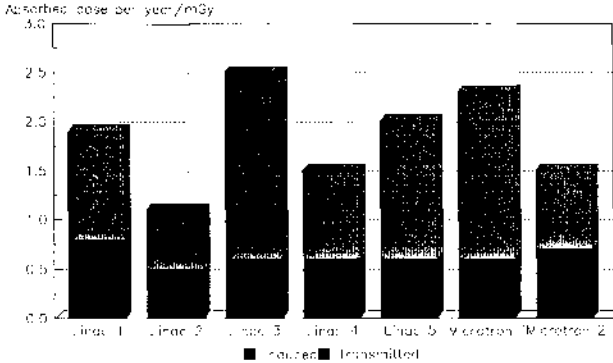

Figure 1 The measured absorbed dose to the trunk extrapolated to one year.

In the same way the absorbed dose to the hand was calculated for the different accelerators to 2.1 mGy. The dose to the hands varies from 0.7 to 3.3 mGy.

A similar investigation (LaRiviere P, 1985) has given comparable absorbed doses. His registered dose outside the treatment room is however lower. This could be due to different measuring techniques or due to that the control console is very distant from the accelerator.

At the control console the average dose rate was measured to 1.6 μ Gy/h. The average leakage dose rate inside the the room was 0.36 mGy/Gy.

A number of radionuclides was identified by examining the halflives. The identified nuclides were also compared with gamma spectroscopy measurments (Ahlgren et al, 1988). An example of the absorbed dose rate curve is given in figure 2.

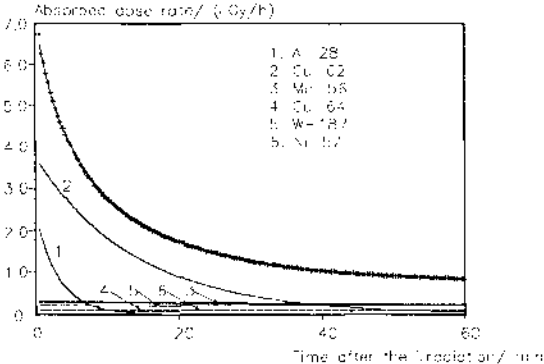

Figure 2 Absorbed dose rate at isocenter in the treatment room 0.5 to 60 min after a termination of the treatment with high energy photons.

The contribution from ^{28}Al ($T_{1/2}=2.3$ min) and ^{62}Cu ($T_{1/2}=9.7$ min) dominates the dose-rate immediately after the treatment. Later the contribution from radionuclides with longer half-lives becomes important. E.g. ^{187}W ($T_{1/2}=24$ h) and ^{57}Ni ($T_{1/2}=36$ h) contributes to the absorbed dose rate in the treatment room due to their relatively long half-lives for several hours. At isocenter the absorbed dose rate is about two times higher than beside the treatment couch.

CONCLUSION

The total annual absorbed dose rate to the technicians was calculated to 2.0 mGy. The absorbed dose to the trunk and to the wrist are very similar. The dose to the hands are probably higher than to the wrist due to the β -particles emitting from the surface of accessories.

Induced radioactivity in the accelerator contributes with 1/3 and the radiation transmitted through the walls of the treatment room contributes with 2/3 to the absorbed dose to the technicians.

The contribution from induced radioactivity is rather constant for the different accelerators indicating the importance of radionuclides with long half-lives as a source of radiation. This also means that the technicians is irradiated every time they enter the treatment room, not solely after treatments with high-energy x-rays.

ACKNOWLEDGEMENTS

This work has been supported by the Swedish Radiation Protection Institute. We also wish to thank all the technicians, nurses and hospital physicists participating in this study.

REFERENCES

- Ahlgren L. and Olsson L.E. (1988). Induced activity in a high energy linear accelerator. *Phys. Med. Biol.* 33, 351-354.
- Almén A., Ahlgren L and Mattsson S. (1991). Absorbed dose to technicians due to induced activity in linear accelerators for radiation therapy. *Phys Med. Biol.* 36 (6), 815-822.
- Forkman B. and Petersson R. (1987) In: Handbook on Nuclear Activation Data. Technical Reports Series No. 273, IAEA, Vienna, 631-811.
- LaRiviere Philip D. (1985). Radiotherapy technologist dose from high-energy electron medical accelerators. *Health Phys.* 49, 1105-1114.
- Lederer L. P. and Shirley V. S. (1978). Table of Isotopes. New York, Wiley.

Neutron Leakage from the Entrance Maze of Medical Electron Accelerators

H.-P. Weise

*Bundesanstalt für Materialforschung und -prüfung (BAM), Berlin,
Federal Republic of Germany*

For medical electron accelerators with photon energies above 15 MeV the shielding requirements in the entrance region of the treatment room are mainly determined by neutron streaming. The accelerator (especially the bremsstrahlung target and the collimator system) is the primary source of fast photoneutrons with an average energy of about 1 MeV. The neutrons are scattered from the walls of the maze resulting in a broad energy spectrum down to thermal energy. For calculating the attenuation factor of the entrance shielding door the neutron dose rate has to be determined using a reliable procedure. Several methods have been proposed for estimating neutron streaming through the maze, e.g.:

- the albedo method which is based on single scattering of fast neutrons from the maze walls,
- a semiempirical method developed by Nakamura et al. which was derived from transport calculations,
- an empirical procedure by Kersey based on measurements at various accelerator installations.

The accuracy of these three procedures was compared by calculating the neutron dose rates for various accelerator facilities for which sufficiently reliable measured data were available. Good agreement between calculated and measured values was generally obtained for the Nakamura method. The Kersey method overestimates the neutron component in some cases. The simple geometric albedo approach however severely underestimates the neutron dose rate at the entrance of the maze. This discrepancy is certainly due to the fact that the simple albedo concept does not take into account the buildup of thermal neutrons by multiple scattering. Measurements with a Bonner spectrometer indicate a considerable contribution of slow neutrons to the total dose rate at the entrance. For the design of the entrance maze the Nakamura method was found to be the most reliable one, the deviation between calculation and measurement for various representative geometries being less than a factor of two.

EXOTIC FILTER MATERIALS FOR DIAGNOSTIC X-RAY EQUIPMENT - ARE THEY SUPERIOR TO COMMONLY AVAILABLE MATERIALS?

P. Dvorak and C. Lavoie
Bureau of Radiation and Medical Devices
775 Brookfield Road
OTTAWA, Canada K1A 0C1

ABSTRACT

Measurements and computer simulations were carried out to evaluate the suitability of various elements for use in X-ray filters. Filter thicknesses were selected to give approximately identical absorbed doses to the image receptor for all elements under consideration. The results suggest that elements in the ranges of atomic numbers from approximately 22 to 42, and above 68 perform about equally well in terms of affecting the phantom dose and image contrast under the conditions used in measurements and simulations. In some specialized applications, exotic filters may have advantage in matching the X-ray spectrum to the image receptor response. These special cases are not considered here.

INTRODUCTION

In diagnostic radiography, filters are used to modify the spectral distribution of photons in an X-ray beam in order to reduce the number of photons that would contribute to the patient dose but not to the acquisition of diagnostic information. Aluminum and, less frequently, copper have been traditionally used in equipment designed for diagnostic procedures other than mammography. In recent years, several less common elements, typically metals from either the rare earth or the fifth period group, have been proposed and tested as filter materials. Adding such filters to the basic filtration, e.g. 2.5 mm Al, results in decreasing both the X-ray dose to the patient and image contrast. Filters tested by the Bureau of Radiation and Medical Devices performed as advertised. An obvious question is whether adding an equivalent thickness of other, more common and less expensive materials, would result in similar changes in the patient dose and image contrast as does adding a more exotic filter.

To evaluate the behaviour as X-ray filters of a large number of elements under various conditions, we developed a computer simulation of the basic X-ray imaging chain. We found good agreement between results of computations and data obtained by actual measurements of film densities and exposures.

COMPUTER SIMULATION AND COMPARISON WITH EXPERIMENT

Figure 1 shows the simulated arrangement. The spectrum calculated according to [1] is filtered through a 1 mm thick glass window and 2.5 mm Al basic filter before reaching the additional filter under evaluation. The filtered beam is attenuated by a phantom, simulating the patient, and two contrast test objects. It passes through the patient support and antiscatter grid, and is finally absorbed by the image receptor.

Mass attenuation coefficients are calculated from the parametrization method developed in Ref. [2], while mass energy absorption coefficients are interpolated from Ref. [3]. Attenuation calculation uses the standard exponential formula

$$E = \int \{E(e) * \exp(-\mu(e) * d)\} de \quad (1)$$

where E is the beam energy fluence, e is the photon energy, E(e) is the spectral distribution of the fluence, and $\mu(e) * d$ is the product of attenuation coefficient and attenuator thickness

while the integral dose uses the formula for thin absorbers [4],

$$D = \int \{E(e) * v(e) / \mu(e) * [1 - \exp(-\mu(e) * d)]\} de \quad (2)$$

where v(e) is the mass energy absorption coefficient, and the other symbols have the same meaning as in (1).

Derivation of Eq. (2) in Ref. [4] can be applied also to thick absorbers, such as phantoms, in a narrow beam geometry.

Since we use the model to compare the behaviour of different filters under identical conditions, we are interested only in relative values. In this case, it is not necessary to include any correction to account for the grid factor. Similarly, we have used the inverse square law to facilitate the comparison with experimental data, but its omission would not influence

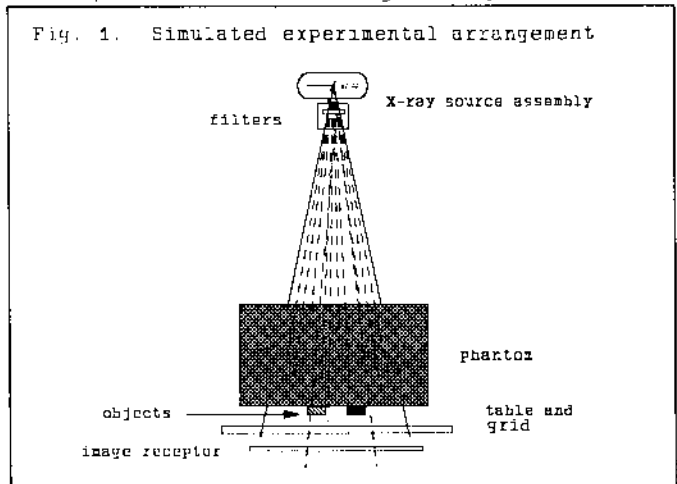

the results of comparison of individual filter materials. The computer model does not take into account the scattered radiation. For comparisons between calculated and measured values, we corrected the measured values by subtracting the estimated contribution of scattered radiation from the reading of the probe used to measure the exposure at the phantom exit and image receptor entrance. We did not use any patient support or grid in this particular case.

Table 1 summarizes the results of comparison. The data are presented in pairs consisting of figures for the filter under consideration and an approximately equivalent copper filter.

Tab.1. Computed and Measured Film Contrasts and Phantom/Phosphor Dose Ratios

kVcp	elem	mm	obj.1 contr.		obj.2 contr.		dose ratio	
			calc	meas	calc	meas	calc	meas
60	Pd	0.025	0.29	0.31	0.43	0.45	28.3	33.8
	Cu	0.1	0.29	0.32	0.43	0.46	25.7	30.6
	Nb	0.03	0.29	0.29	0.44	0.44	28.9	33.9
	Cu	0.075	0.29	0.28	0.44	0.43	28.1	33.3
	Er	0.1	0.28	0.29	0.42	0.45	27.2	30.2
	Cu	0.175	0.28	0.33	0.42	0.44	20.6	24.0
80	Pd	0.025	0.32	0.31	0.49	0.49	37.1	36.5
	Cu	0.125	0.32	0.31	0.48	0.46	31.9	37.7
	Nb	0.03	0.33	0.32	0.49	0.49	37.0	40.7
	Cu	0.075	0.33	0.31	0.49	0.48	35.6	38.5
	Er	0.1	0.33	0.33	0.49	0.47	33.2	33.4
	Cu	0.275	0.30	0.30	0.46	0.46	26.2	28.3
	Mo	0.03	0.33	0.29	0.49	0.43	36.1	32.1
	Cu	0.175	0.31	0.29	0.47	0.44	29.4	31.1
100	Pd	0.025	0.27	0.26	0.40	0.42	28.3	30.4
	Cu	0.125	0.27	0.26	0.40	0.39	25.7	27.5
	Nb	0.03	0.27	0.28	0.41	0.46	28.9	30.5
	Cu	0.075	0.27	0.28	0.41	0.41	28.1	30.0
	Er	0.1	0.27	0.31	0.41	0.47	27.2	27.2
	Cu	0.375	0.25	0.27	0.37	0.39	20.6	21.6

Fig.2. Computed Values of Dose Ratios and Contrasts

Figure 2 shows the calculated values of object contrasts and relative doses for several simulated situations, with filter materials and thicknesses listed in Table 2.

Conditions simulated in Table 1 and Figure 2: X-ray tube voltage 60, 80 and 100 kVcp (approximated by a three phase generator operating at low X-ray tube current), phantom 113 mm H₂O, objects 11.8 (not shown in Fig.2) and 17.6 mm polymethylmethacrylate.

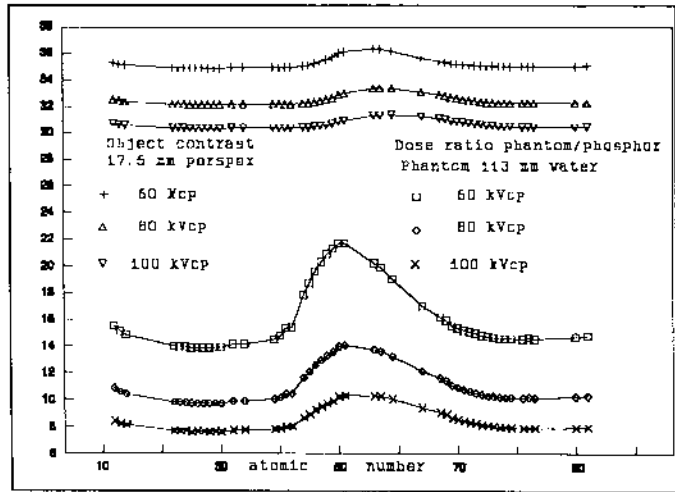

Tab.2. Filter Thicknesses in Fig.2 Computations

elem.	mm	elem.	mm	elem.	mm
12 Mg	3.2	41 Nb	0.03	69 Tm	0.028
13 Al	1.75	42 Mo	0.026	70 Yb	0.0375
14 Si	1.7	44 Ru	0.017	71 Lu	0.0265
22 Ti	0.295	45 Rh	0.016	72 Hf	0.0195
23 V	0.2	46 Pd	0.015	73 Ta	0.015
24 Cr	0.145	47 Ag	0.017	74 W	0.0133
25 Mn	0.128	48 Cd	0.02	75 Re	0.0123
26 Fe	0.105	49 In	0.0225	76 Os	0.0108
27 Co	0.085	50 Sn	0.023	77 Ir	0.0108
28 Ni	0.075	51 Sb	0.025	78 Pt	0.0109
29 Cu	0.068	56 Ba	0.054	79 Au	0.0117
30 Zn	0.079	57 La	0.031	81 Tl	0.018
32 Ge	0.088	59 Pr	0.031	82 Pb	0.018
34 Se	0.085	64 Gd	0.029	83 Bi	0.0205
39 Y	0.075	67 Ho	0.0275	90 Th	0.0145
40 Zr	0.042	68 Er	0.027	92 U	0.008

The filter thicknesses listed in Table 2 result in approximately identical doses absorbed in the image receptor under conditions shown for Table 1 and Figure 2. Calculations of the solid bone contrast (not shown) result in the same pattern of dependence on the atomic number of the filter as found for polymethylmethacrylate. Some of the elements listed in Table 2 may not be suitable for X-ray filters because of their mechanical or chemical properties, radioactivity, or cost.

CONCLUSION

The results of measurements and computations suggest that, under the conditions used in this work, there is no noticeable difference in performance as filter materials for elements in the ranges of atomic numbers from approximately 22 to 42, and above 68. Advantages of special filters designed for matching the X-ray spectrum with image receptor response are not treated in this paper.

REFERENCES

1. Birch, R. and Marshall, M., 1979, Computation of Bremsstrahlung X-Ray Spectra and Comparison with Spectra Measured with a Ge(Li) Detector, *Phys. Med. Biol.*, 24, pp. 505-517
2. Quellet, R.G. and Schreiner, L.J., 1991, A parametrization of the mass attenuation coefficients for elements with $Z=1$ to $Z=92$ in the photon energy range from 1 to 150 keV, *Phys. Med. Biol.* 36, pp. 987-999
3. Storm, E. and Israel, H.I., 1970, Photon cross-sections from 1 keV to 100 MeV for elements $Z=1$ to $Z=100$, *Nuclear Data Tables*
4. McDavid, W.D. and Waggener, R.G., 1974, Average Absorbed Dose in Thin Absorbers, *Phys. Med. Biol.* 19, pp. 107-108

TEST OF MAMMOGRAPHIC EQUIPMENT BY AN OBJECTIVE ASSESSMENT
OF IMAGE QUALITY AND DOSE

J.F. Valley¹⁾, L. Desponds²⁾, C. Depeursinge²⁾,
M. Grecescu¹⁾, C. Hessler³⁾

- 1) Institute for Applied Radiophysics, CH-1015 Lausanne
- 2) Institute for Medical Engineering, CH-1024 Ecublens
- 3) University Medical Center, CH-1011 Lausanne

ABSTRACT

A method for simultaneous determination of dose and image parameters in mammography is presented. A single exposure of a suitable phantom is needed, followed by the film analysis on a microdensitometer. The objective assessment of image quality is based on the image quality index, a global concept developed by the authors. The radiation risk to the patient is estimated by the mean glandular dose.

The procedure has been used in several evaluation tasks of radiological equipment, material and techniques : influence of anode and filter material, comparison of screen-film combinations, limitations of the magnification technique.

INTRODUCTION

Radiological examination is an effective method in the diagnostic of pathology of the female breast. The new radiological equipments allow to obtain a high image quality enabling the detection of microcalcifications of the order of 100 μm . On the other hand the absorbed dose to the breast must be controlled and held to the lowest possible value, owing to the high radiation sensitivity of this organ. The test of mammographic equipments has to take both aspects, image quality and dose, into account. Additionally, the assessment should be objective in order to convince both physicians and technicians.

In the case of image quality several approaches have been proposed for the objective assessment : signal-to-noise ratio, detective quantum efficiency, information capacity (1). However these parameters have no direct connection to the radiological task and are difficult to be perceived and correlated to clinically significant features. In our approach we developed as quality index the diameter of the smallest microcalcification which the system can detect. This quantity is derived from the measured basic quality parameters : contrast, noise and resolution. The mean glandular dose will be used to evaluate the radiological risk.

CONCEPT OF IMAGE QUALITY INDEX

The image quality index (IQI) is defined as the diameter of the smallest detectable spherical object with a high probability of correct decision. In a first approach (2), the IQI has been derived assuming a Gaussian MTF and a white noise; it was given by the following formula :

$$IQI = \frac{2}{m} \left(\sigma_h^2 + 2 \frac{G}{C \pi^{1/2}} \right)^{1/2}$$

where m is the object magnification, σ_h the width of the Gaussian line spread function, G the Selwyn granularity coefficient and C the image contrast.

The model was further improved using statistical decision theory for 'quasi-ideal' observer (3). In this case the signal-to-noise ratio (SNR) is given by the following expression :

$$SNR = \frac{C \int df_x \int df_y S^2(f_x, f_y) MTF^2(f_x, f_y)}{(\int df_x \int df_y S^2(f_x, f_y) MTF^2(f_x, f_y) W(f_x, f_y))^{1/2}}$$

Where $S(f_x, f_y)$ is the object form in the spatial frequency domain, MTF the modulation transfer function and W the Wiener spectrum.

The value of SNR is calculated for different object dimensions using the measured system parameters (C , MTF, W). The SNR value corresponding to visual detection has been derived by visibility tests (2). Their comparison yields the IQI value.

EXPERIMENTAL PROCEDURE

The image quality parameters and the dose are measured using a Lucite mammographic phantom 53 mm thick. Test objects, embedded in the phantom, allow the measurement of the image quality parameters on a radiograph :

- contrast, by measuring the transmission of an aluminium plate,
- resolution, by measuring the profile of a copper foil edge,
- noise, by scanning a uniformly exposed surface with a microdensitometer.

The surface dose is measured using thermoluminescent dosimeters; the mean glandular dose is calculated using conversion factors measured in a BR12 phantom.

The performance assessment of mammographic equipment needs a single exposure of the phantom and subsequently an analysis of the radiograph with a microdensitometer and a measurement of the thermoluminescent dosimeters.

APPLICATIONS

Influence of anode and filter material

The influence of anode and filter material on the image quality and dose has been measured using the procedure described above. The three following anode-filter combinations were used : W-Mo, W-Rh and Mo-Mo. The results obtained are given in figure 1.

The Mo-Mo and W-Mo combinations give similar results. The W-Rh combination at an IQI of 100 μ m implies a lower dose, but is not able, in the voltage range used, to produce IQI values as low as the molybdenum filtration.

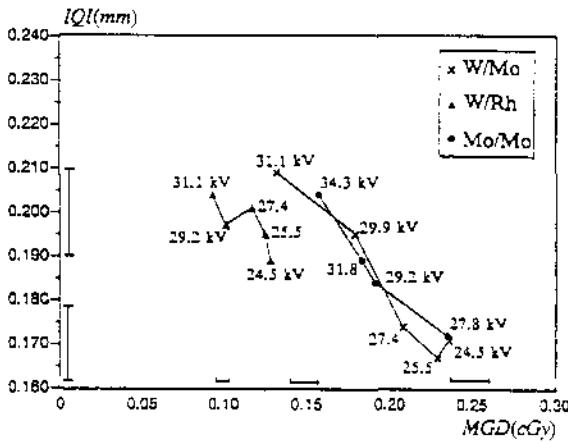

Fig.1. Image quality index (IQI) versus mean glandular dose (MGD) for three anode-filter combinations

Comparison of screen-film combinations

A set of screen-film combination has been tested using our method. The list of the combinations and the results obtained are given in figure 2.

No	Description (écran-film)
A1	Agfa MR Detail - Agfa MR3-II
A2	Agfa MR Detail S - Agfa MR5-II
D	Dupont Microvision - Dupont Cronex
F1	Fuji HR fine - Fuji MI-MA
F2	Fuji HR fine - Fuji MI-NH
F3	Fuji HR fine - MI-NC
K1	Kodak Min-R Fast - Kodak T-Mat M II
K2	Kodak Min-R Medium - Kodak Min-R
K3	Kodak Min-R Medium - Kodak PE 205
K4	Kodak Min-R Medium - Kodak OrnoMA
K5	Kodak Min-R - Kodak Min-R
K6	Kodak Min-R - Kodak PE 205
K7	Kodak Min-R - Kodak OrnoMA
K8	Kodak Min-R - Kodak MinRH
3M1	3M T1 - 3M SX
3M2	3M T1 - 3M FM
3M3	3M T2 - 3M SX
3M4	3M T2 - 3M FM

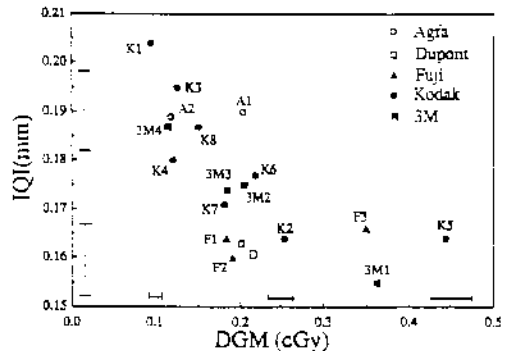

Fig.2. Performances of different film-screen combinations

The results are clustered around a hyperbolic curve, showing that each system corresponds to a compromise between image quality and dose.

Assessment of the magnification technique

The magnification technique using an air-gap between the breast support and the film has been tested. This method is claimed to

improve the quality compared to the classical system using a grid for scatter reduction. The results are presented in figure 3.

For thin breasts, owing to the low doses, the magnification technique is acceptable until a magnification factor of 2. For mean thickness breasts (around 35 mm), the magnification factor should not be greater than 1.5; for this value the dose is the same as for the classical method (without magnification and with grid), but the image quality is clearly improved. For thick breasts (~ 50 mm) magnification is critical because of the high dose involved.

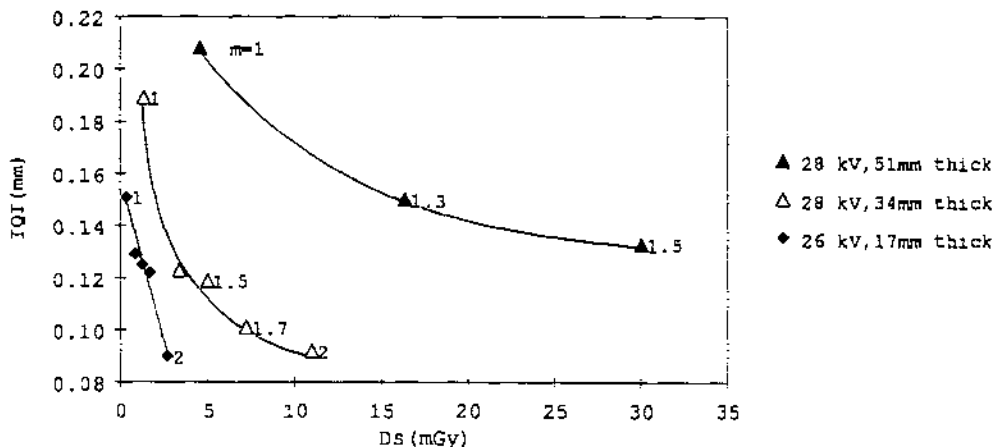

Fig.3. Performance of the magnification technique (m:magnification)

CONCLUSIONS

The assessment method presented here has the following advantages:

- the method is objective avoiding the tedious ROC approach;
- it is global, giving simultaneous information about image quality and dose;
- it is easy to apply, a single exposure being needed.

The applications of the method have proved its efficiency and gave insights in the radiological procedures.

REFERENCES

1. Loo, L.N., Doi, K., and Metz, C.E., 1984, A comparison of physical image quality indices and observer performance in the radiographic detection of nylon beads, *Phys. Med. Biol.*, 29, 837-56.
2. Hessler, C., Depeursinge, C., Grecescu, M., Pochon, Y., Raimondi, S., and Valley, J.-F., 1985, Objective assessment of mammography systems, part I : method, *Radiology* 156, 215-19.
3. Desponds, L., Depeursinge, C., Grecescu, M., Hessler, C., Samiri, A., and Valley, J.-F., 1991, Image quality index (IQI) for screen-film mammography, *Phys. Med. Biol.*, 36, 1, 19-33.

IMPLEMENTATION OF THE QUALITY ASSURANCE PROGRAMME
OF THE X RAY RADIATION IN SERBIA - YUGOSLAVIA

Tomasevic Miroslav, Kosutic Dusko, Marinkovic Olivera

Abstract : Under constant dosimetric control in Serbia there are 782 diagnostic X ray units with 969 X ray tubes. In 1990, 202 such units were subjected to the radiation dose reproducibility testings; 206 to measurement of high voltage and accuracy of exposure time. In 94.55% cases the said reproducibility amounted less than five percent and only 1.98% was higher than 10%. The exposure time was reliably determined in 78.15% X ray generators; deviations in excess of 10% were registered in 21.48%. Similar situation occurred in selection of high voltage. Of observed X ray generators in 10-12% cases deviations increased ten percent.

Introduction :

The scope of ionizing application, and particularly its medical use is controlled by the Federal laws and Regulations passed during the period from 1986 - 1989 (1.2.3.4). All ionizing irradiation sources are constantly subjected to the regular dosimetric control performed by specialized, highly qualified and adequately equipped institutions authorized by Republic i.e. Regional legal regulations. Owing to some changes in legal regulations, the dosimetric control of all ionizing irradiation sources is reestablished on the completely different base using Quality Assurance Program. The basic provisions of the Program, accepted in our country as well, (But not in all Republics) are given in revised and supplemented version of the aforementioned Legal Regulations from 1989 (3).

The results of performed testing :

In order to meet the proposed criteria related to the scanning of certain organs and the parts of the body selection of adequate high voltage (kV) values, X-ray tube current (mA) and duration of scannings is to be selected at the X-ray apparatus control panel, ranging within the permitted variation of 10%. Since these values directly influence the dose of X-ray irradiation exerted to the patient it means that it must not exceed the proposed limits. The results of irradiation doses reproducibility testing in 1990. are presented in Table 1.

Table 1 - DOSSES

The type of X-ray unit	Pcs	Measured deviations					
		< 5%		>5% and <10%		> 10%	
		Pcs	%	Pcs	%	Pcs	%
DENT	57	55	96.49	2	3.51	0	0.00
SELENOS 4	71	65	91.55	3	4.23	3	4.23
SUPERIX 800	25	24	96.00	1	4.00	0	0.00
SUPERIX 1000	39	38	97.44	0	0.00	1	2.56
SUPERIX 1250	10	9	90.00	1	10.00	0	0.00
TOTAL	202	191	94.55	7	3.47	4	1.98

According to the accepted criteria, among all tested X-ray units, irradiation doses deviation exceeding 10% was found only in 4: in 3 SELENOS 4 x-ray generators and 1 SUPERIX 1000 generator. Presented values revealed no significant difference of measured deviations in certain X-ray generators.

Following the accepted criterion that only those X-ray generators in which the accuracy and reproducibility of the exposure time range within the permitted variation of only 10% may be considered as satisfactory, it was found that a number of tested generators failed to meet the criterion. Among tested X-ray generators, 21.85% failed to meet the proposed criterion while remaining 78.15% revealed satisfactory testing results. (Table 2)

The accuracy and reproducibility of high voltage, on the basis of direct measurement of high voltage of 70kV, 80kV, 90kV and 100kV were evaluated in diagnostic X-ray units subjected to the testing. The results for 70kV are in Table 3.

Table 2 - TIME

The type of X-ray unit	Pcs	Measured deviations					
		< 5%		>5% and <10%		> 10%	
		Pcs	%	Pcs	%	Pcs	%
DENT	58	25	43.10	17	29.31	16	27.59
SELENOS 4	73	41	56.16	8	10.96	24	32.88
SUPERIX 800	25	18	72.00	5	20.00	2	8.00
SUPERIX 1000	40	33	82.50	5	12.50	2	5.00
SUPERIX 1250	10	8	80.00	1	10.00	1	10.00
TOTAL	206	125	60.68	36	17.47	45	21.85

Table 3 - HIGH VOLTAGE : 70 kV

The type of X-ray unit	Pcs	Measured deviations					
		< 5%		>5% and <10%		> 10%	
		Pcs	%	Pcs	%	Pcs	%
SELENOS 4	28	22	78.57	5	17.86	1	3.57
SUPERIX 800	24	13	54.17	9	37.50	2	8.33
SUPERIX 1000	34	16	47.06	12	35.29	6	17.65
SUPERIX 1250	7	3	42.86	3	42.86	1	14.29
TOTAL	93	54	58.07	29	31.18	10	10.75

CONCLUSION AND SUGGESTED MEASURES

The results of our initial tests, performed at X-ray units manufactured in Yugoslavia justify the necessity of diagnostic X-ray units control as a routine procedure. In spite of the fact that measured values mostly ranged within the proposed limits, we believe that more detailed and more reliable results related to the diagnostic X-ray units performances are to be obtained through further investigations.

REFERENCES :

1. Sl list SFRJ br. 62/84
2. Sl list SFRJ br. 40/86
3. Sl list SFRJ br. 31/89
4. Sl list SFRJ br. 45/89
5. Quality Assurance in Diagnostic Radiology.
WHO. 1982

RADIOACTIVE CONTAMINATION DUE TO NUCLEAR
MEDICINE EXAMINATIONS IN LIQUID AND GASEOUS MAIRICES

G.Testoni*, T.Bernardi*, D.Berti*, O.Tubertini**, R.Zannoli*

* Servizio di Fisica Sanitaria dell'Università di Bologna

** Centro di Radiochimica Ambientale. Dipartimento di Chimica
"G.Ciamician - Università di Bologna.

Measurements carried out since 1980 on the radioactivity of liquid wastes produced by the city of Bologna and due to the activity of Nuclear Medicine Departements.

Radioactivity was measured in the fumes produced by sewage sludge inceneration too.

INTRODUCTION

The "Servizio di Fisica Sanitaria" of the University of Bologna checks radioactive pollution and its environmental impact due to scientific research and industrial or medical activity.

Because of the past experience, we can conclude that the most important radioactive impact is due to the Nuclear Medicine Departements (Malpighi and Maggiore Hospitals).

Liquid wastes produced by the city of Bologna and surrounding areas are collected by a sewage system, leading to a depuration plant; the capacity of the sewage system is about 250,000 mc per day.

The samples (about 200 in June 1991) were taken at the entrance and exit of the city depurator. Radioactivity was measured in muds, ashes and fumes produced by treatment of the depuration.

Samples were gathered "in continuo" from the liquid at entrance by means of a fractions collector during all the week night and day.

The depuration cycle produces about 10,000 tons muds. The muds combustion yields 750 tons ashes and 10 million mc fumes per year.

The radioactivity in the fumes was collected on cellulose filters and active coal caps by means of a suction pump during 30 minutes (3 mc per min.).

Before letting into atmosphere, fumes were washed with depurated water that was tested too.

We did not regularly check the activity of beta-emitter radionuclides, since they are used only for analysis "in vitro" and liquid waste is not released into the sewage system, nevertheless some untreated samples (1 ml) were tested and no radioactivity was found.

MATERIALS AND METHODS

For beta-emitters radionuclides, to 1 ml sample 12 ml scintillation liquid HT Ready Solv. (Beckman) were added, and then the mixture was tested by a Beta-counter Beckman LS-100 during 8 hours

For gamma ray spectrometry we gathered samples of the liquids at entrance and exit of the depurator, of the ashes, of the fumes, and of the fumes washing water.

1 litre of untreated sample was counted in "Marinelli" beaker (anular geometry) by a high-purity Germanium coaxial detector (2 KeV resolution at 1330 KeV, relative efficiency 30%) or a 3"x3" NaI(Tl) crystal (6,5% resolution at 662 KeV). Minimum detectable activity was about 0,5 Bq/litre.

The cellulose filters and active coal caps were tested in the same counting-chaine, but in an other geometry.

The counting-chaine calibration was performed by a calibrated source QCY-44 (Amersham) in aqueous solution.

Quantitative valuations were carried out for Tc-99m, I-131, I-125, Tl-201, Ga-67, Xe-133, Cr-51, Co-57 with a counting time of 2000-5000 sec.

RESULTS

The results are explained in the following figures and tables.

Fig.1 illustrates input capacity of depurator during a day , and the quantity of Tc-99m measured in an hour.

Fig.2 Refers the weekly course of Tc-99m in entrance at the depurator.

In tab.1 are compared the activities administered to the patients in a week, with the activities in entrance at the depurator, in fumes, in ashes and in the fumes washing water.

Tab.1

	Tc-99m	I-131	I-125	Tl-201	Ga-67	Xe-133	Cr-51	Co-57
A.A.	85459	5595	567	3145	1813	2400	.6	.074.
L.EN	22441	1375	-	Traks	258	13	Traks	Traks
FUMES	-	.0025	-	-	.035	-	-	-
ASCH.	7,2	-	-	2,3	7	Traks	-	Traks
WAW	17	28	-	-	12	-	-	-

A.A. : Activity administered to the patients at the Nuclear Medicine Departements (Malpighi and Maggiore Hospitals).

L.EN : Activity measured at the entrance of the depurator.

FUMES : Activity measured in the gases leaving the burning plant.

ASCH. : Activity measured in the ashes produced by combustion of muds.

WAW. : Activity measured in the fumes washing water.

Activity is measured in Bq X 10⁶.

Fig.1 ----- Capacity measured in $m^3/h (\times 10^3)$
 +---+ Activity measured in Bq/l

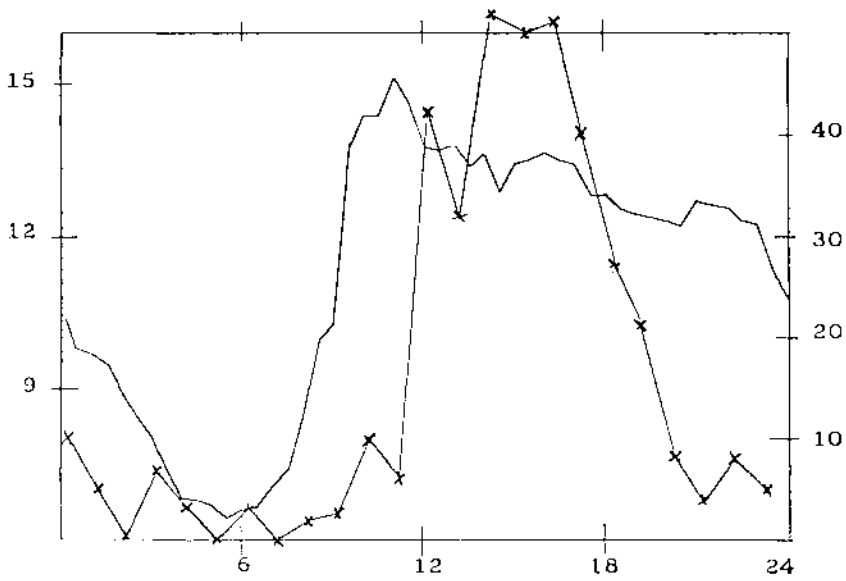
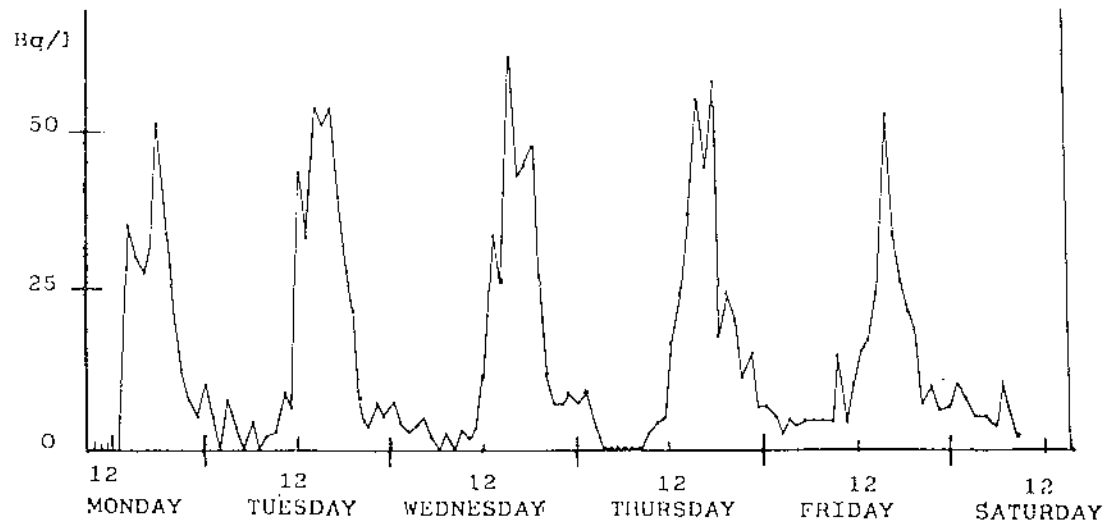

Fig.2



CONCLUSIONS

1) If H-3 and C-14 are present in the Bologna sewage system, they are not measurable by our equipment (in any case less than 1Bq/ml)

2) The radioactive impact due to the Nuclear Medicine Departments is not particularly important (till now!).

3) The transit through the sewage system and the depuration process strongly pull down the radioactivity of used nuclides, because of their low average-time.

4) The radioactivity in the gases leaving the depurator is completely negligible.

REFERENCES

- Adams, F. and R. Dams. 1975. Applied gamma-ray spectrometry. Pergamon Press Ltd., Oxford.
- Belli, M., F. Dobici e S. Terrani. 1980. Aspetti di radioprotezione connessi con gli scarichi nell'ambiente. Convegno Nazionale AIRP Venezia, 168-180.
- Bernardi, T., G. Testoni e O. Tubertini. 1983. Inquinamento radioattivo della rete fognaria di Bologna. 3° Convegno Nazionale di Radioecologia. 154-161.
- Bernardi, T., G. Orlandi, G. Testoni e O. Tubertini. 1983. Radio-nuclidi γ -emettitori nella rete fognaria di Bologna.
- Browne, E., J.M. Dalrymple, and R.E. Doebbler. 1976 Table of isotopes. John Wiley and Sons, Inc.
- Colangelo, S., G.C. Cortellessa e S. Terrani. Risultati di misure di radioattività nella rete di fognatura di Milano, in relazione a scarichi radioattivi. XV Congresso A.I.F.S.P.R.
- Ferretti, P.P. e A. Borrini et al. 1980. Rifiuti radioattivi liquidi nelle attività di un reparto di Medicina Nucleare: 1° - eliminazione in fogna. Annali di Radioprotezione 109-124.
- Regione Emilia Romagna. 1978 Controllo e smaltimento dei rifiuti radioattivi degli Enti Ospedalieri. Rapporto tecnico: Assessorato alla Sanità di Bologna.
- Testoni, G., G. Orlandi, T. Bernardi e O. Tubertini. 1985. Misure di radioattività al Depuratore della rete fognaria di Bologna.
- Testoni, G. et al. 1988. Radioactive contamination in the Bologna Sewage System due to Nuclear Medicine Examinations. 7° IRPA Sydney 11-19 Aprile 1988.

We sincerely thank the "Unità Operativa Difesa e Ambiente del Dipartimento dei Servizi Tecnici" and the "Azienda Municipalizzata Igiene Urbana" of Bologna for their essential collaboration.

RADIOTHERAPIE METABOLIQUE PAR ^{131}I : RISQUES DE CONTAMINATION ET D'IRRADIATION DU PERSONNEL SOIGNANT

L' ^{131}I est utilisé en thérapeutique pour le traitement des hyperthyroïdies (111 à 1110 MBq), des nodules autonomes extinctifs (NA) (740 MBq) et des cancers thyroïdiens (C) (3700 MBq).

Chez quinze patients (10 C, 5 NA) ont été mesurés le taux de fixation en regard du parenchyme thyroïdien, l'élimination urinaire quotidienne de l' ^{131}I , l'activité résiduelle et la distance correspondant à un débit de dose de $2,5 \cdot 10^{-2}$ mSv/h à la sortie (J+4) :

- Taux de fixation moyen : C : 4,8 % - NA : 28,1 %
- L'élimination urinaire est représentée en pourcentage cumulé de l'activité administrée

(cf courbe)

- L'activité résiduelle du patient à la sortie : - C : 536 MBq - NA : 381 MBq
- Distance $2,5 \cdot 10^{-2}$ mSv/h : - C : 22 cm - NA : 84 cm

Elimination urinaire en pourcentage cumulé de l'activité administrée

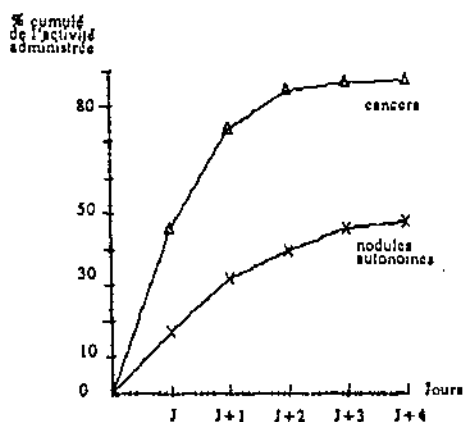

CONCLUSION : L'hospitalisation en secteur radioprotégé est justifiée, surtout pour les cancers, par les risques de contamination du personnel par les urines (2035 MBq éliminés les douze premières heures pour les C contre 148 MBq pour les NA). A J+4, l'élimination urinaire devient relativement faible dans les deux pathologies (C : 37 MBq ; NA : 17 MBq).

Par contre, à J+4, le débit de dose Gamma est quatre fois plus important pour les NA que pour les C, ce qui pose le problème de l'irradiation du personnel en secteur non protégé.

Ionizing Radiation Sources Used in Medical Applications in Brazil

S.M.V. Oliveira, A.M.C. Araujo and G. Drexler*

Instituto de Radioproteção e Dosimetria - IRD,
Nat. Nuclear Energy Commission - CNEN, Rio de Janeiro, Brazil

*Institut für Strahlenschutz,
GSF - Forschungszentrum für Umwelt und Gesundheit GmbH,
D - 8042 Neuherberg

Abstract

Data about ionizing radiation sources used in medical applications in Brazil and obtained through a IRD/CNEN national programme together with Brazilian health authorities are presented. This study used the geographic country division into five regions. The results are analyzed for each region. Due to many demographic, social and economic differences among these regions, some modifications are proposed to the UNSCEAR collection data model, for developing countries with similar situations.

Introduction

This inventory began with an IRD programme in Rio de Janeiro state (Southeast Region) where radiation protection and quality control inspections were performed in 2,000 diagnostic and 4,000 odontological X-ray equipments. The programme was extended in 1987 to other states (table 1). In one of them - Espirito Santo state (also Southeast Region) - the inventory is already completed: in the last years neither the number of diagnostic radiology equipment increased nor was the broken equipment replaced. In other states where the inventory is presently continuously updated - Acre and Rondonia (North Region) Paraíba and Ceara (Northeast Region), Sao Paulo (Southeast Region), Parana (South Region) and Goias (West Region) - the X-ray equipment is increasing with population increment. In the remaining states available data is shown but should be analysed separately since the collecting methodology was quite different (table 2).

Main results

In an UNSCEAR classification (health care level I - IV) Brazil in total can be classified to be in health care level I/II (table 3) with significant variations between the geographical regions. Using the correlation of X-ray equipment per inhabitants the classification is II/III and indicators like odontological consultations or radiodiagnostic examinations show decreasing tendency with time (fig. 1). Thus the health care level in Brazil is comparable i.e. with India or China.

Regarding the radiological examinations distribution among the main types, it was observed that the frequency for preventive procedures is lower than for the corrective procedures (fig. 3). Furthermore, in developing countries like Brazil, the population distribution in cities and countrysides (table 1) must be considered separately, because the health resources in countrysides are much smaller.

Optimizing procedures in health care thus must utilize many indicators in order to identify the actual situation and to initiate necessary actions.

Conclusions

To describe the situation and estimate deficiency resp. the needs of a country as well as to assess population exposures, the relationship among more health indicators and socio-economic variables should be considered. The results obtained have also demonstrated that a data collection standardization is necessary and unique statistical methodology analysis should be elaborated and implemented.

Nuclear Medicine and Radiotherapy data in Brazil should be more detailed. According to UNSCEAR Report 1988 nuclear medicine and the therapeutic uses of radiation is increasing in developing countries and the need for quality control will arise.

References

- 1) United Nations Scientific Committee on Effects of Atomic Radiation. Sources, Effects and Risks of Ionizing Radiation. Report to the General Assembly (1988)
- 2) Drexler, G., Cunha, P.G., Peixoto, J.E.: Medical and Occupational Exposures in Brazil. Radiat. Prot. Dosim. 36, 101-105 (1991)
- 3) Peixoto, J.E., Campos, M.C., Chaves, R.Q.: A Data Base for the National Radiation Control Programme in Medical and Dental Radiography. Internat. IAEA Symp. on Radiation Protection Infrastructure, Munich (1990)
- 4) Instituto Brasileiro de Geographica e Estatistica (IBGE). Medical Sanitary Assistance, Rio de Janeiro (1987)
- 5) Instituto Nacional de Previdencia Social (INAMPS): 1987 Annual Report, Rio de Janeiro (1987)

Table 1 - Population Distribution

Regions	Inhabitants (x 1,000)	in Brazil (%)	Urban (%)	Country (%)
North	7,894	3	-	-
Northeast	39,764	29	56	44
Southeast	60,400	45	85	15
South	21,100	16	66	34
West	9,329	7	72	28
Brazil	138,487	100	73	23

Table 2 - National Inventory

Regions	Diagnostic X-ray Facilities	Diagnostic X-ray Equipment	Dental X-ray Equipm.	Radiother. Facilit.	Nuclear Med. Facil.
North	255	468	512	2	3
Northeast	1,123	2,011	1,466	23	19
Southeast	2,701	8,674	20,355	74	91
South	1,072	1,852	891	16	23
West	368	907	1,642	6	11
Brazil	5,519	13,912	24,866	121	147

Table 3 - Health Care Level

Classi- fication	Inhabitants/ Physicians	Regions	States
	< 500	West	Brasilia (OF)
I	500 - 999	North	Roraima, Amapa
		Northeast	Rio G. Norte, Paraiba, Alagoas
		Northeast	Pernambuco, Ceara, Bergipa
		West	Mato Grosso, Mato G. do Sul
		Southeast	Espirito Santo, Minas Gerais
		Southeast	Rio de Janeiro, Sao Paulo
		South	Santa Catarina, Rio G. Sul
II	1000-1.999	North	Rondonia, Amazonas, Para
		Northwest	Piuaf, Bahia
		South	Parana
		West	Goiias
	2000-2.999	North	Acre
		Northwest	Maranhao

Sources: IRD/CNEN, 1989; IBGE, 1987

X-RAY EXAMS FREQUENCY

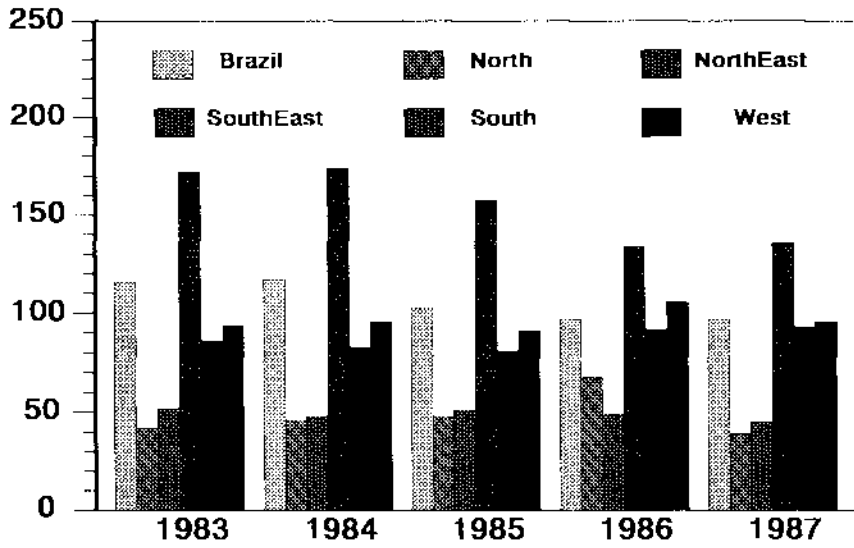

Fig. 1

DIAGNOSTIC X-RAYS

MAIN EXAMINATION DISTRIBUTION

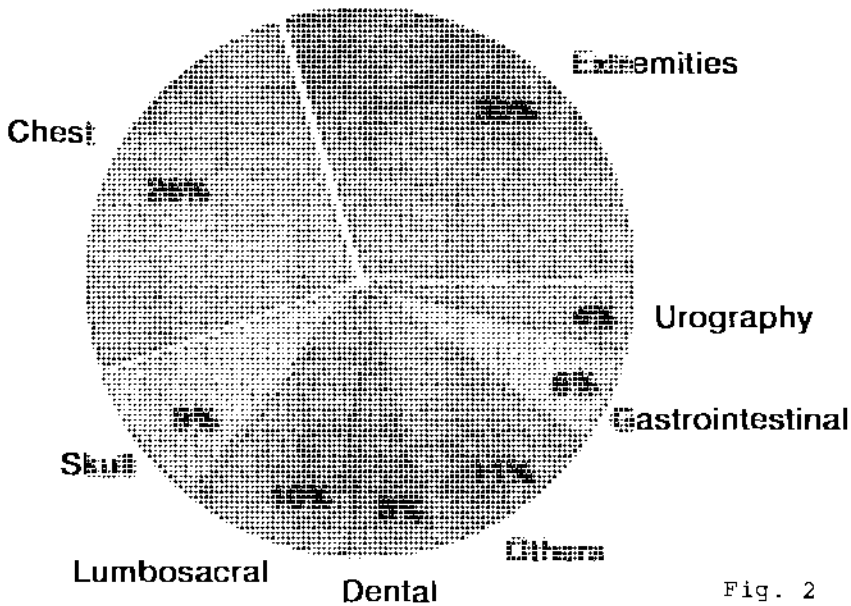

Fig. 2

THE INTERNATIONAL CHERNOBYL PROJECT

Abel J. González

Deputy Director, Division of Nuclear Safety
International Atomic Energy Agency, Vienna, Austria

ABSTRACT

The findings of the International Chernobyl Project are summarized herewith. The project focused on four key issues related to the radiological consequences of the Chernobyl accident which are of concern to the population and policy makers: the true extent of the current contamination in inhabited areas of Belarus, Russia and the Ukraine; the past, current and future radiation exposure of the population; the actual and potential health effects; and the adequacy of measures being taken to protect the public. The project findings are expected to contribute towards alleviating the consequences of the accident by presenting factual information to allow future policy and worldwide assistance to be channelled to where it is most needed and where it can be best used.

INTRODUCTION

1. In response to a governmental request, the International Atomic Energy Agency (IAEA) organized a multinational team to assess the current radiological situation after the Chernobyl accident in the three more affected Republics, Belarus, Russia and the Ukraine. Seven international bodies participated: CEC, FAO, IAEA, ILO, UNSCEAR, WHO and WMO. Thus, the International Chernobyl Project was formalized in February 1990.
2. A group of ten scientists designed a strategic approach after a fact-finding mission in March 1990. This group met with officials in Moscow and the Republics' capitals, scientific organizations, hospitals, clinics and agricultural centres in the affected areas and in Kiev, Gomel and Moscow. They also discussed project plans with residents of seven settlements in the three Republics, who predominantly expressed anxieties about children's health and the adequacy of the Government's proposed measures for limiting radiation exposures within their lifetime, as well as mistrust against the authorities and against scientific and medical committees.
3. Subsequently, an International Advisory Committee (IAC), consisting of 21 members from 7 international organizations and 10 countries (including radiation specialists, medical practitioners and psychologists), was established to direct the project and assess findings. The IAC met 23-27 April 1990 in Kiev and Minsk to define the project structure and work plan to be completed in 1 year with limited resources. The task that evolved was to assess the quality and correctness of existing data and to conduct an independent study by means of laboratory analyses of field samples and internationally recognized assessment techniques. It focused on four key issues of concern to the population and policy makers: the true extent of the current contamination in the Republics' inhabited areas; the past, current and future radiation exposure of the population; the actual and potential health effects; and the adequacy of measures taken to protect the public. The project conclusions and recommendations were approved by the IAC in Vienna 18-22 March 1991 and presented for scrutiny to an international conference of experts in Vienna 21-24 May 1991. The findings are contained in a Technical Report which should be referred to for further technical details. (See Fig. 1.)

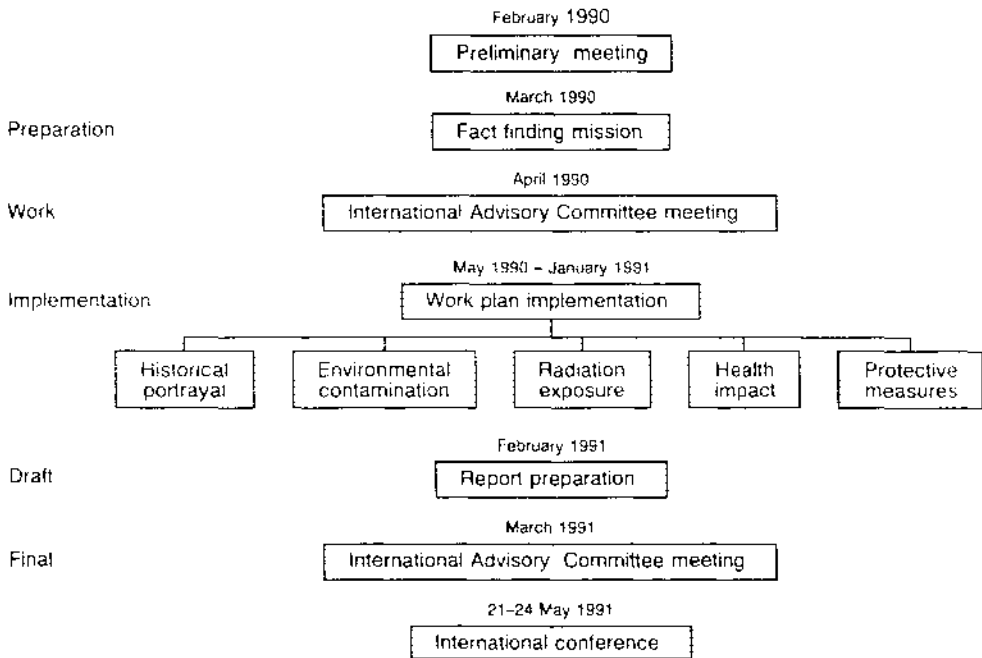

The International Chernobyl Project. The Project was organized in response to a governmental request for an international assessment of the radiological consequences of the Chernobyl accident. The multinational effort was directed by the International Advisory Committee and included the participation of the CEC, FAO, IAEA, ILO, UNSCEAR, WHO and WMO. Five tasks defined the Project implementation: historical portrayal of the events leading to the current radiological situation, the evaluation of the environmental contamination, the evaluation of the radiation exposure of the population, the assessment of the health impact from radiation exposures and the evaluation of the protective measures.

Figure 1

GOALS AND SCOPE

4. The project dealt exclusively with the radiological consequences for the inhabitants of affected areas: approx. 25,000 km² with ground concentration levels of Cs over 5 Ci/km² (58% located in Belarus, 32% in Russia and 9% in the Ukraine), covering a population of 825,000 (45% live in Belarus, 24% in Russia and 31% in the Ukraine) residing in over 2,000 settlements in the three Republics. The project did not cover the prohibited region (approximately 30 km in radius around the damaged reactor) or the emergency personnel ("liquidators") who carried out recovery operations after the accident.

WORK PLAN

5. Surveys were performed on 27 "surveyed contaminated settlements", some with relatively high soil surface contamination, others with relatively low soil surface contamination but with the potential for high radiation doses to the population through the food chain. For comparison, surveys were also conducted on 7 "surveyed control settlements" outside the contaminated areas. In addition, a number of information exchange activities were carried out to enhance the level of understanding of the problems involved among the local scientific community.

PARTICIPATION

6. Some 200 experts from research institutes, universities and organizations in 25 countries and 7 multinational organizations participated in the assessment. Approximately 50 missions were undertaken between March 1990 and January 1991. The IAEA Seibersdorf Laboratory together with 13 laboratories in 6 countries collected and analysed samples and conducted an intercomparison exercise with laboratories in Belarus,

Russia and the Ukraine. Governmental authorities and commercial companies in 5 countries donated equipment, supplies, radiation monitors and computing time. Project teams made 2,000 measurements of external gamma dose rates, ecosystem and milk, monitored almost 22,000 inhabitants for external and internal exposures and performed approximately 1,500 medical examinations. Overall efforts concentrated on assessing the reliability and accuracy of data, techniques and methodologies used to estimate contamination levels, doses and health effects and evaluating radiological protection policies.

MAJOR FINDINGS

7. From the radiological point of view, the relevant radioactive contaminant still remaining in the area is Cs-137, Sr 90 and Pu-239 being potentially interesting. The contamination values in available maps for Cs-137 and Pu-239 were generally corroborated, while Sr 90 results were lower than reported. (See Fig. 2.) Water and food contamination was below Codex Alimentarius levels.

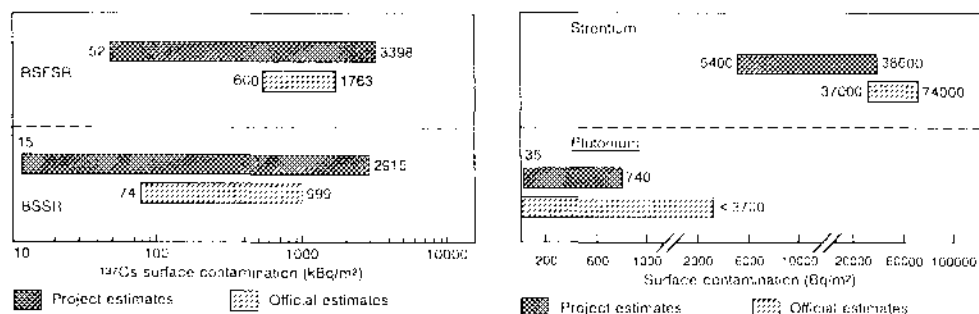

Comparison of Project measurements of caesium soil contamination with official values of caesium surface contamination for settlements of Belarus and Russia. Limited Project sampling of caesium contamination in top soils in five settlements of Belarus and four settlements of Russia indicated values that were consistent with the range of the official values based on comprehensive surveys carried out since the accident and reported for these settlements by the State Committee on Hydrometeorology and Environmental Monitoring, Moscow.

Comparison of Project measurements of strontium and plutonium soil contamination with official values for surface contamination in the Bragin region, Belarus. The Project concluded that analytical results for a limited set of soil samples corresponded to the reported estimates for plutonium but were lower than those for strontium. As illustrated here for settlements in the Bragin region, the measurements of strontium contamination suggest the potential for overestimation in the official values reported by the State Committee on Hydrometeorology and Environmental Monitoring, Moscow.

Figure 2

8. The official procedures for estimating doses were scientifically sound and the methodologies used were intended to provide results that would not underestimate the doses. However, independent project estimates were lower than the officially reported dose estimates. (See Fig. 3.)

9. No health disorders were found that could be attributed directly to radiation exposure; however, significant non-radiation-related health disorders do exist in the affected area. (See Fig. 4.) There are also substantial psychological consequences in terms of anxiety and uncertainty. No current increase in the incidence of leukemia or cancer could be substantiated and future potential increases in cancer would be difficult to discern. These general conclusions on the health situation were followed by a number of detailed conclusions, some related to neoplasms, in particular to the many reported increases in cancer and to the potential future cancer increase, as follows: USSR data indicated that reported cancer incidence had been rising for the last decade and has continued to rise at the same rate since the accident; the project team considered that there had been incomplete reporting in the past and could not assess whether the rise is due to increased incidence, methodological differences, better detection and diagnosis or other causes; the data did not reveal a marked increase in leukemia or thyroid tumours since the accident; on the basis of estimated project doses and currently accepted radiation risk estimates, future increases over the natural incidence of all cancers or hereditary effects would be difficult to discern, even with large and well designed long term epidemiological studies; however, reported estimates of absorbed thyroid dose in children are such that there may be a statisti-

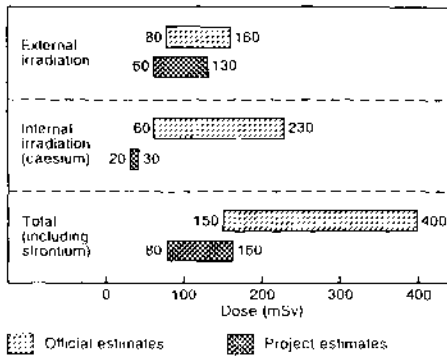

Comparison of Project estimates and officially reported estimates for radiation dose to the population in selected settlements. Project dose estimates derived independently were compared with the official values for the population in the selected settlements as reported by the Institute of Biophysics, Moscow. As illustrated here, the Project estimates were lower than the officially reported dose estimates. Overall, there is general agreement within a factor of 2-3.

Figure 3

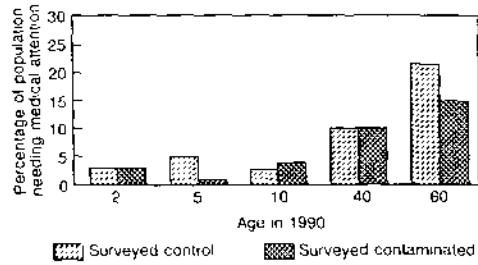

Project assessment of the general health of the population in selected settlements. The Project assessment of reported increases in illness attributed to the Chernobyl accident included an investigation of the general health of the population in selected settlements. Independent medical examinations of inhabitants of both surveyed contaminated and surveyed control settlements revealed no health disorders that could be attributed directly to radiation exposure, but did indicate significant non-radiation-related health disorders among the adult population. As illustrated here, Project results indicated that 10-15 per cent of the adult population examined in both surveyed contaminated and surveyed control settlements should be referred to a physician for follow-up medical care.

Figure 4

ably detectable increase in the incidence of thyroid tumours in the future. Examination of nearly 800 children showed no difference in height and weight between those living in contaminated settlements and those in control settlements with no contamination. Comparison with growth pattern norms in the USA indicate that children are generally healthy and their diet is adequate. Medical examinations showed that thyroid size and size distribution, as well as thyroid nodules, were similar to those reported in other countries.

10. With regard to protective measures, it was found that measures taken or planned exceed what is strictly necessary on radiological grounds. Relocation and foodstuff restrictions should have been less extensive. However, the project concluded that relaxing current policy could be counter-productive (although more restricted criteria should not be adopted) and social and political factors must be considered. (See Figs. 5 and 6.)

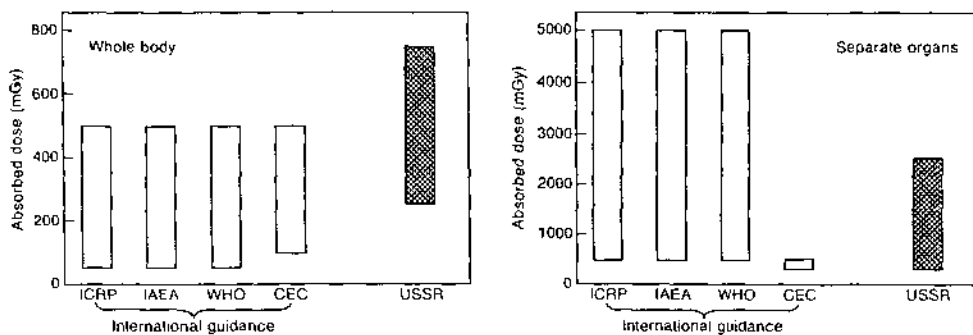

Criteria for evacuation of the population in the early phase of the Chernobyl accident. While the Project team was not able to investigate in detail many of the early protective actions taken by the responsible authorities, it was judged that the general response of the authorities was broadly reasonable. As illustrated here, the intervention levels of absorbed dose for evacuation applied in the early phase of the post-accident response by the authorities were consistent with general guidance prevailing at the time of the accident (the vertical columns indicate the upper and lower levels of the guidance values.) Absorbed dose is defined as the energy absorbed per unit mass of tissue.

Figure 5

LONG TERM RELOCATION CRITERIA

Long term relocation concepts were established at first on the basis of a lifetime dose of 350 mSv (35 rem) as the intervention level for relocation, the so-called 'lifetime dose limit'. Subsequently, a surface contamination of 40 Ci/km² (1480 kBq/m²) was introduced as the intervention level for relocation. The bases on which the criteria for relocation were derived were not wholly consistent with the principles currently recommended internationally. However, the International Advisory Committee concluded that "The protective measures taken or planned for the longer term, albeit

well intentioned, generally exceed what would have been strictly necessary from a radiological protection viewpoint." The table gives estimates of dose averted for the various intervention concepts. The Committee concluded that "measures are not justified on radiological protection grounds; however, any relaxation of the current policy would almost certainly be counter-productive in view of the present high levels of stress and anxiety amongst inhabitants of the contaminated areas of concern and people's present expectations."

Criterion	Year of application	Level	Lifetime dose averted from external radiation (mSv)	Lifetime dose averted from external radiation and residual ingestion dose (mSv)
Temporary annual dose limit	1986	100 mSv per annum		
	1987	30 mSv per annum	~ 140	< 240
	1988	25 mSv per annum	~ 130	< 230
	1989	25 mSv per annum	~ 150	< 260
Lifetime dose limit	1990	350 mSv lifetime	~ 60	< 130
Surface contamination	1990	> 40 Ci/km ² surface	~ 80	< 160
	1990	< 15 Ci/km ² surface	~ 30	< 80

Figure 6

SUMMARY

11. The major conclusions of the International Chernobyl Project can be summarized as follows: the official surface contamination levels were generally corroborated; the radiation doses incurred and expected future doses are lower than originally estimated; significant non-radiation related health disorders and negative psychological consequences in terms of stress and anxiety were found, but no health disorders were detected that could be directly attributed to radiation exposure; early protective measures were reasonable and consistent with international guidelines, measures taken or planned for the long term (relocations and foodstuff restrictions) exceed those which would be necessary on radiological grounds.

12. The findings have been published in an Overview for policy makers and the scientific audience and a comprehensive Technical Report for the scientific audience, both available in English and Russian. Several brochures for the general public have also been published in English and Russian. The full proceedings of the international conference that scrutinized the project are also available.

13. The International Chernobyl Project results as presented by the IAC represent an important contribution to alleviate the consequences of the Chernobyl accident. Factual information will allow future policy as well as worldwide assistance to be channelled to where it is most needed and to where it can be best used.

SOME GENERAL CONCLUSIONS FROM SIX YEARS OF CHERNOBYL-RELATED RESEARCH IN SWEDEN

Ulf Bäverstam and Leif Moberg

Swedish Radiation Protection Institute
Box 60 204, S-104 01 Stockholm, Sweden

ABSTRACT

A large research programme has been carried through by Swedish scientists as a follow-up of the Chernobyl accident. The long-term behaviour of cesium in the agricultural and aquatic ecosystems shows many similarities with previous experience. This is also true for the reindeer ecosystem. The effects of the cesium fallout on cultivated soils can be substantially decreased by various actions. Large-scale mitigating actions show only minor effects on effective half-times of cesium in fresh-water fish. The contamination of radionuclides in the forest ecosystem is even more difficult to influence. Measurements of resuspension show lower values than earlier findings. Shielding factors for houses generally confirm earlier theoretical estimates. The average radiation doses to people in Sweden are dominated by the external radiation, while the internal doses can potentially be very large and dominate for some individuals. On average the doses after Chernobyl are about the same as those after the nuclear bomb tests.

INTRODUCTION

An extensive research programme has been carried through in Sweden, motivated by the fallout from the nuclear accident in Chernobyl. A major part of this research has been financed and co-ordinated by the Swedish Radiation Protection Institute (SSI). An extensive summary of the results has recently been published (Moberg, ed). Results presented in this article are taken from that book. The programme has encompassed studies of the transport of radioactive elements to Sweden, deposition mechanisms, fallout characterization and deposition measurements. It has been estimated that 5 percent of the released amount of Cs-137 was deposited in Sweden. The deposition was, however, very uneven, with larger areas obtaining a Cs-137 contamination of more than 100 kBq/m², and in extreme cases more than 200 kBq/m².

Extensive measurements with air-borne detectors, and *in situ* gamma spectrometry allowed the deposition pattern to be determined. This knowledge has then constituted valuable background information for a number of measurements as well as for the action taken by the authorities.

Research in the long time perspective has been focussed on the behaviour and effects of the only long-lived gamma-emitters, Cs-134 and Cs-137, and especially on the transport and accumulation in the terrestrial and aquatic environments, activity measurements on man and dose calculations.

RADIATION DOSES

The average fifty-year dose for individuals in Sweden is about the same as that received as a consequence of the atmospheric bomb tests. The variation in doses between individuals is, however, much larger after Chernobyl,

due both to the non-uniform deposition and to the large variation in intake. The resulting total effective dose commitment to man in Sweden is summarized in this table.

<u>Collective dose (manSv)</u>		<u>Individual dose (mSv)</u>	
External	Internal	External	Internal
		(ratio max/min)	
5000	1000	0.6 (50-100)	0.1 (10 ³ -10 ⁴)

Of special interest are groups living in high-deposition areas with diets including large amounts of game meat, reindeer and freshwater fish, for example reindeer-breeding Sami families. Whole-body measurements show that individuals from this group receive average internal doses 100 times that of the average Swede. On the other hand, people who buy their food and live in low-deposition areas receive a dose equal to one tenth of the average value.

The external dose follows more closely the deposition pattern and constitutes the larger part of the collective dose commitment after Chernobyl, in average five times larger than the dose commitment from intake.

TERRESTRIAL RADIOECOLOGY

The high levels of cesium concentration in lichens, the predominant fodder for reindeer during the winter season, subsequent to fallout are well known since the sixties. This time, however, the maximum values were more than ten times higher than after the bomb tests. The effective half-time of Cs-137 in lichen was found to be 8-14 years during the sixties and recently repeated measurements on residual bomb-caesium give values of 8-10 years. Even if the time elapsed since the Chernobyl accident is short, preliminary results indicate half-times in the range 6-15 years, i.e. similar to earlier experience. A number of actions have been taken to decrease the consequences. Moving reindeer to areas with lower deposition, use of bentonite to decrease uptake in the reindeer, adding cesium-free food to the diet prior to slaughter, and the use of zeolites are methods that have been tested with varying degrees of success.

In spite of these actions a large number of slaughtered reindeer have been discarded for selling in the open market. For reindeer in some areas the long half-time of cesium in lichen will be a problem for some decades.

Studies of the radioactive contamination of the forest ecosystem in Sweden were limited during and after the sixties. Results from post-Chernobyl observations of the amount of Cs-137 remaining in different parts of the boreal ecosystem, the fraction lost by run-off, the concentration prevailing in plants in important food-chains and concentrations in moose indicate that changes in levels about one-year after the initial deposition will be exceptionally slow. In fact, it will probably be governed by the physical decay of the radioactive cesium. One consequence of this is that

the collective dose from forest products might be of the same order as that from agricultural products. However, this will be clarified by further studies. The concentrations of cesium in moose and roedeer, in particular, are also high. The variations between individual animals, years etc are large.

Radioecological questions related to agriculture have been studied right from the end of the fifties. A basis of knowledge existed prior to the Chernobyl accident. However, even though the pre-Chernobyl studies were in progress over a long period, the aims were restricted. The studies after Chernobyl have opened up a wider scope. On a large number of sites the cesium transfer both to grass and grain crops has been measured. The results have increased the experience on the effect of soil composition on cesium transfer to crops, on the importance of the nuclide depth distribution and variations due to differences in the agricultural systems used. Results from experiments with different levels of potassium fertilization are generally in agreement with earlier findings. Transfer coefficients of radioactive cesium to cow's milk show a large range of values, but are similar to those which were generally accepted before the accident.

AQUATIC RADIOECOLOGY

A number of radionuclides originating from the accident were detected in the marine biota of the Baltic Sea. The only ones frequently observed in fish were Cs-134 and Cs-137. A major fraction of the total load of Cs-137 to the Baltic Sea was transferred to the sediments already during the first year. The accumulation of cesium in fish in the Baltic Sea is much smaller than in freshwater fish, and the radiological consequences from the contamination of the Baltic Sea were quite small.

In lake ecosystems a rapid incorporation of Cs-137 resulted in high concentrations. Organisms at lower trophic levels reached their maximal activity concentrations already during 1986. The predator fish reached maximum values the following years, the exact time depending on the type of lake and species. A major part of the Cs-input was relatively early deposited on the bottom sediments. Resuspension of cesium from the sediments has been found to be an important reason for delayed recovery in some lakes. Fish that consume macro invertebrates which feed on the contaminated sediment layer can cause sustained accumulation of cesium. In particular, this has been demonstrated in oligotrophic high-altitude lakes.

The apparent half-time of cesium in fish varies considerably (0.6-13 years) depending on the type of lake, species, age of the fish etc. However, the half-times for large perch and large pike seem to be similar to those found during the sixties.

It is known that the content of stable potassium in the water is negatively correlated to the concentration of Cs-137 in fish but potash treatment of lakes after the deposition does not seem to be a very effective way to speed up recovery. The treatment performed in oligotrophic lakes imply that the recovery can never be more than 5% faster compared with no treatment. This result is supported also by recent Swedish laboratory experiments on Chernobyl contaminated fish and water. Once the lake is contaminated with cesium, a subsequent addition of potassium has little effect on the half-time. Liming of lakes shows the same negative results.

MODEL TESTING

The Chernobyl databases have been utilized to test environmental transfer models primarily within the international BIOMOV5 study. Two main cases, based on lake and vegetation-milk data, were investigated. The accuracy of the predictions for water and sediment was found to be satisfactory for most radioecological assessments. The discrepancies were higher for fish. For the milk pathway about half of the predicted time-integrated concentrations of I-131 and Cs-137 in vegetation were within a factor of two from the observed values, while for the time-integrated predictions of I-131 and Cs-137 in milk the discrepancies were higher.

The available data sets, prolonged in time, will be available for future model testing and analyses.

THE FALLOUT

As a result of the relatively high deposition in some parts of Sweden it has been possible to perform field measurements of a number of parameters (dry and wet deposition velocities, resuspension, shielding factors for houses) which earlier had to be estimated from small-scale experiments or measured in environments different from those in Sweden. The measured shielding factors for houses confirm earlier theoretical estimates based on experiments. Measurements of resuspension show lower values than those often used prior to the Chernobyl accident.

GENERAL CONCLUSIONS

It would appear that many of the results and many conclusions after Chernobyl support corresponding earlier data. The very slow recovery in the forest ecosystem had not previously been fully appreciated.

The average doses in Sweden are low, and comparable to the doses obtained from the atmospheric testing of nuclear weapons. However, the variation in doses between individuals is much larger after Chernobyl. It is important that the deposition took place before the growing season, and that the major farming areas of Sweden received a very low contamination which contributed to the fact that there were such low doses from agricultural products.

The results are very similar to those from the sixties. There is, however, an important difference between the research in the eighties and that in the sixties. Today a more ecological approach is encountered. This fact, which at least in part is explained by the larger number of scientists trained in ecology and taking part in radioecological research, contributes to the fact that the present-day results have a higher credibility than those of former years.

REFERENCE

The Chernobyl fallout in Sweden. Results from a research programme on environmental radiology. L Moberg (Ed.), pp 633. Available from the Swedish Radiation Protection Institute, Box 60 204, S-104 01 Stockholm, Sweden

**EVALUATION OF COUNTERMEASURES TO BE TAKEN TO ASSURE SAFE LIVING
CONDITIONS TO THE POPULATION AFFECTED BY THE CHERNOBYL ACCIDENT
IN THE USSR**

J. LOCHARD - T. SCHNEIDER

Centre d'étude sur l'Evaluation de la Protection dans le domaine Nucléaire
BP 48, F 92263 Fontenay-aux-Roses Cédex - France

N. KELLY

Commission of the European Communities - DG XII.D.3
13, rue du Luxembourg, 1049 Brussels - Belgium

This paper presents a first estimation, performed in 1990, of the cost and averted collective exposure of the potential relocation of the population from the affected territories of Russia, Byelorussia and Ukraine, to improve their living conditions following the Chernobyl accident. A general and simplified modelling approach was adopted in the evaluation. Results suggest that from a strict radiological protection viewpoint, it would have been very difficult to justify any allocation of resources to relocate the population living in areas with less than 40 Ci/km². The study has also indicated the need for further investigations on various points.

1. INTRODUCTION

Following the Chernobyl accident a variety of measures were taken to protect those affected from exposure to radiation. Once the immediate effects of the accident were dealt with, attention turned to longer term considerations, in particular how to ensure "safe" living conditions for those living beyond the evacuated zone. In 1989, criteria were proposed to restore "normal" living conditions. In those settlements where the criterion was exceeded people would be relocated; in the remaining settlements normal living conditions, with no restrictions on food nor people's habits, would resume. Considerable debate and argument arose over the appropriateness of this criterion. In an attempt to resolve some of these disagreements, the Soviet Government requested the International Atomic Energy Agency (IAEA) to organise an international group of experts to review and evaluate the measures being taken to assure "safe" living conditions for those people continuing to live in the affected areas. This paper presents a first estimate of the effectiveness of the measures adopted within the so-called "State All-Union and Republican Programme for Urgent Measures for Eliminating the Consequences of the Chernobyl Accident for 1990-1992" by the Soviet Supreme of the USSR in April 1990 [1]. This study has been performed under contract for the Commission of the European Communities within the framework of the IAEA International Chernobyl Project [2].

2. METHODOLOGY AND DATA

Based on dosimetric and economic data collected in USSR during summer 1990, a general and simplified modelling approach was adopted in the evaluation. The basic input to the model is the distribution of the population living in the affected areas as a function of the level of ground contamination expressed in Ci/km² of Cs-137 [3]. The corresponding total population was about 705,600 people for the three Republics (Russia, Ukraine, and Byelorussia), and was considered to be representative of those living in these areas at the beginning of 1990, for levels above 5 Ci/km².

The doses corresponding to a given contamination level have been derived from a generic dosimetric model developed at the Institute of Biophysics in Moscow. The model is based on simple expressions, which are used to derive the external and internal doses in a given year, as a function of the surface Cs-137 contamination, when no restrictions exist. The average relationships between the dose and contamination level are presented in Table 1.

Table 1: Average relationships between surface contamination, individual annual dose (for 1990) and individual lifetime dose (1990-2060)^a

Surface contamination Cs-137 (Ci/km ²)	Annual effective dose equivalent in 1990 (mSv)	Lifetime effective dose equivalent (1990-2060) (mSv)
5	≈ 2	≈ 40
15	≈ 5	≈ 90
40	≈ 13	≈ 210
80	≈ 25	≈ 410

a) Doses were estimated in the absence of any protective measures

In the absence of any protective measures, the total collective dose for the 1990-2060 period, for people living in the zones with more than 5 Ci/km² (500,000 people between 5 to 15 Ci/km², 200,000 between 15 to 40 Ci/km², 15,000 between 40 to 80 Ci/km², 1,000 above 80 Ci/km²), was estimated to be about: 54,000 man-Sv.

3. COST AND EFFECTIVENESS OF COUNTERMEASURES

In the absence of adequate data, the model only considered protective measures in two broad categories: relocation of the population, and improvement of living conditions. Of the many measures taken to improve living conditions, only a few have a significant effect on the doses received; the provision of clean food is perhaps the most important in this respect. Relocation was assumed to be totally effective, and the dose was considered to be zero as soon as the population has left the contaminated area. Two further aspects have been considered. First, for social and economic reasons, the relocation of a given settlement or a set of settlements, may necessitate the additional relocation of neighbouring settlements where these are economically dependent on those relocated. Secondly, there may be many people in each Republic who wish to be relocated, even when the level of contamination is below the criterion.

As far as costs are concerned, all costs used in the model were taken from the "State All-Union and Republican Programme" [1]. Two categories of costs have been distinguished: "one off" costs, and annual costs. Based on a detailed analysis of the resources allocation in the three Republics, the cost "per capita" of relocation and improvement of living conditions were estimated.

4. PROTECTION STRATEGIES

The current State All-Union and Republican Programme was based on the following criteria for the countermeasures:

- improvement of living conditions for the population living in

areas where the ground contamination was above 5 Ci/km²;

- relocation for the population living in areas where the ground contamination was above 40 Ci/km².

These two basic protective measures have been combined into strategies fitting with the generic conceptual framework presented in Figure 1. The value of 5 Ci/km² has been adopted in the model for level A. Expressed in terms of annual dose in 1990 or lifetime dose, this contamination level was corresponding to:

- . an average annual effective dose equivalent in 1990 = 2.2 mSv/y
- . an average lifetime effective dose equivalent (1990-2060) = 37 mSv

assuming no protective measures were taken. Altogether, 11 strategies have been evaluated with the model in which different values have been assumed for level B, the level above which it was assumed that relocation was implemented.

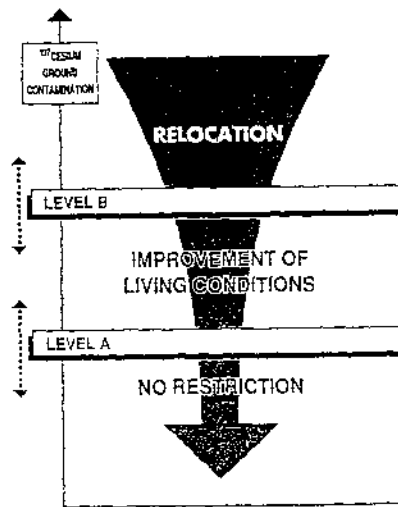

Figure 1: Basic scheme for the definition of "protective strategies"

5. COST-BENEFIT ANALYSIS

Strictly speaking, the evaluation of the various strategies was based on a differential cost-benefit analysis, here called cost-benefit analysis for simplification. To make judgements on the marginal costs per unit dose averted by the various strategies, it was necessary to introduce a reference value for the cost of the man-Sievert. The approach adopted in this study was to combine the use of a baseline monetary value of the man-sievert calculated according to the human capital method with a risk aversion factor, increasing with the level of contamination, to reflect the general attitude of the population living in the contaminated areas. The final conclusion concerning the level above which relocation was justified, was clearly conditional upon the attitude towards aversion. Based on the most conservative assumptions only population above 40 Ci/km² should have been relocated. Figure 2 presents the range of level of ground contamination (40 to 80 Ci/km²) for which the marginal cost of countermeasures and the marginal cost of the detriment are of the same order taking into account the sensitivity of the key parameters.

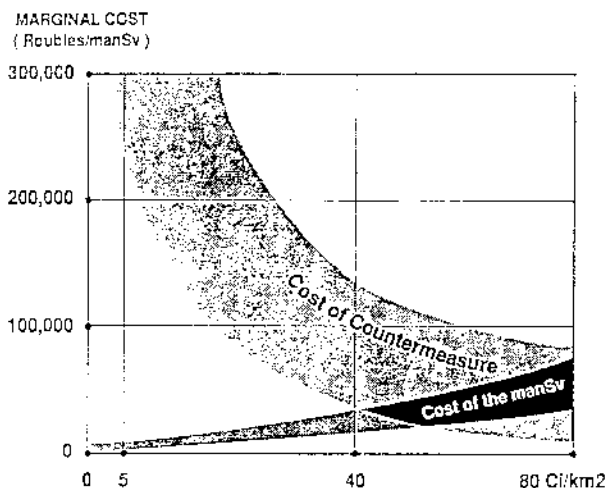

Figure 2: Cost-benefit analysis

6. CONCLUSION

This analysis was an attempt to provide a coherent framework for all the available data in 1990 concerning the cost and doses averted associated with various relocation strategies. Ideally the analysis should have been undertaken on a settlement by settlement basis, where proper account could have been taken of local variations in dosimetric and economic data. However, because of data limitations this was not possible. Using a baseline value of the man-Sievert, estimated on the basis of human capital considerations, the evaluation led to the conclusion that it was not justified to relocate anyone from the controlled zones. With some allowance for risk aversion, the results suggested that there were no strong arguments for the implementation of further measures other than those already envisaged, unless relocation costs would differ largely from the base case. Nevertheless, some other factors of a social or political nature could justify a more restrictive approach [4].

ACKNOWLEDGMENTS

We wish to express our sincere thanks to all the scientists and members of public ministries in the Republics of Byelorussia, Russia, and Ukraine, and at the All-Union level, for their help.

REFERENCES

- [1] "State All-Union and Republican Programme for Urgent Measures for Eliminating the Consequences of the Chernobyl Accident for 1990-1992". Moscow, 1990.
- [2] Lochard J., Schneider T. "Countermeasures to be taken after 1990 to assure safe living conditions for the population affected by the Chernobyl accident in the USSR: a first evaluation of costs and doses averted". CEPN Report n° 179, April 1991.
- [3] Linge I.I. "Dose related distribution of population from contaminated areas (5 Ci/km² of Cs 137 and above)". Institute of Biophysics. USSR Ministry of Public Health. September 1990.
- [4] French S. "The Decision Conferences in the USSR", in *The International Chernobyl Project: Technical Report, IAEA, 1991, Annex 3, Part G.*

MODELING OF THE TRANSFER OF IODINE AND CESIUM VIA THE GRASS-COW-MILK PATHWAY AFTER THE CHERNOBYL ACCIDENT

Gerald Kirchner

University of Bremen, Dept. of Physics, Postfach 330440, D-2800 Bremen 33, FRG

ABSTRACT

More than 60 data sets of time dependent activities of iodine and cesium in grass and milk measured after the Chernobyl accident are evaluated using the concepts of linear compartmental theory. The transfer kinetics can be described by models including two (^{131}I) or three (^{137}Cs) compartments. Calculated weathering half lives and equilibrium transfer coefficients into milk are in the range of values reported in reviews of experimental data based on observations of atomic weapons fallout and on laboratory experiments.

INTRODUCTION

After the Chernobyl accident many measurements of time dependent activities of iodine and cesium isotopes in grass and milk samples were performed. Based on the analysis of 62 datasets¹⁻¹⁵, both the structure of compartmental models which adequately describe the kinetics of the transport of ^{131}I and ^{137}Cs via the grass-cow-milk pathway and numerical values of radioecological parameters are presented in this paper.

CALCULATIONAL METHODOLOGY

From datasets including nuclide concentrations in the milk of single animals both the structures of *minimal* compartmental models which adequately describe the measured transfer kinetics and numerical values of the associated transfer rates were calculated using the concepts of linear compartmental theory¹⁶. Additionally, equilibrium transfer coefficients grass \rightarrow milk were calculated. As averaged milk samples do not represent the transfer kinetics of the individual animals¹⁶, for these data sets only equilibrium transfer coefficients could be determined.

RESULTS AND DISCUSSION

Results of the analyses are given in Tab. 1, structures of the minimal compartmental models are shown in Fig. 1. For both nuclides feeding experiments established the existence of a long-term storage compartment¹⁷ which in a part of the datasets of Tab. 1 is not observed. Explanations could be (a) experiments of too short duration, (b) difficulties to resolve processes with numerically small transfer rates from data scattering (especially in the case of experiments with constant nuclide intake), (c) problems to fit experimental data to sums of more than three exponentials¹⁸.

Mean values of weathering half-lives - 5.9 ± 0.7 d (^{131}I) and 9.5 ± 0.9 d (^{137}Cs) - are in good agreement with data given in a previous review¹⁹.

The range of equilibrium transfer coefficients given in Tab. 1 agrees well with nuclear weapons fallout data²⁰, but their mean values of $(3.8 \pm 0.5) \cdot 10^{-3}$ d/ ℓ (^{131}I) and of $(3.4 \pm 0.3) \cdot 10^{-3}$ d/ ℓ (^{137}Cs) are lower.

Tab. 1 : Minimal compartmental models, weathering half-lives, $t_{1/2}^{\psi}$, and equilibrium transfer coefficients, TF, of the data sets analysed

Data-set no.	Site	Nuclide	Model structure ^(a)	$t_{1/2}^{\psi}$ [d]	TF [10^{-3} d/ℓ]	
1	Geel	¹³¹ I	(1)	8.4 ± 0.5	1.1 ± 0.1	ref. 1
2	Uenzen	¹³¹ I	(3)	5.7 ± 0.8	3.8 ± 0.4	ref. 12
3	Uppsala	¹³¹ I	(1)	18.8 ± 9.2	6.4 ± 1.2	ref. 3
4	Uppsala	¹³¹ I	(1)	18.8 ± 9.2	4.7 ± 0.8	ref. 3
5	Uppsala	¹³¹ I	(1)	18.8 ± 9.2	3.5 ± 0.6	ref. 3
6	Uppsala	¹³¹ I	(1)	18.8 ± 9.2	4.8 ± 0.9	ref. 3
7	Uppsala	¹³¹ I	(1)	18.8 ± 9.2	5.0 ± 0.8	ref. 3
8	Uppsala	¹³¹ I	(1)	18.8 ± 9.2	4.5 ± 0.8	ref. 3
9	Uppsala	¹³¹ I	(1)	18.8 ± 9.2	5.1 ± 0.9	ref. 3
10	Uppsala	¹³¹ I	(1)	18.8 ± 9.2	5.2 ± 0.8	ref. 3
11	Neuherberg	¹³¹ I	(1)	- ^(b)	8.2 ± 0.8	ref. 3
12	Neuherberg	¹³¹ I	(1)	- ^(b)	5.9 ± 0.5	ref. 3
13	Neuherberg	¹³¹ I	(1)	- ^(b)	8.4 ± 0.7	ref. 9
14	Geel	¹³⁷ Cs	(2a),(2b) ^(d)	25.5 ± 10 ^(e)	1.8 ± 0.1	ref. 1
15	Uenzen	¹³⁷ Cs	(3)	9.7 ± 1.1	7.0 ± 0.8	ref. 12
16	Uppsala	¹³⁷ Cs	(1)	20.7 ± 4.3	1.9 ± 0.1	ref. 3
17	Uppsala	¹³⁷ Cs	(1)	20.7 ± 4.3	2.0 ± 0.1	ref. 3
18	Uppsala	¹³⁷ Cs	(1)	20.7 ± 4.3	1.8 ± 0.1	ref. 3
19	Uppsala	¹³⁷ Cs	(1)	20.7 ± 4.3	1.3 ± 0.1	ref. 3
20	Uppsala	¹³⁷ Cs	(1)	20.7 ± 4.3	1.6 ± 0.1	ref. 3
21	Uppsala	¹³⁷ Cs	(1)	20.7 ± 4.3	1.6 ± 0.1	ref. 3
22	Uppsala	¹³⁷ Cs	(3)	20.7 ± 4.3	2.5 ± 1.7	ref. 3
23	Uppsala	¹³⁷ Cs	(1)	20.7 ± 4.3	1.7 ± 0.1	ref. 3
24	Uppsala	¹³⁷ Cs	(3)	20.7 ± 4.3	2.5 ± 0.9	ref. 3
25	Uppsala	¹³⁷ Cs	(3)	20.7 ± 4.3	1.9 ± 0.2	ref. 3
26	Uppsala	¹³⁷ Cs	(1)	24 ± 11	6.5 ± 1.0	ref. 3
27	Uppsala	¹³⁷ Cs	(1),(3) ^(d)	24 ± 11	7.4 ± 1.1	ref. 3
28	Uppsala	¹³⁷ Cs	(1)	24 ± 11	7.2 ± 0.9	ref. 3
29	Uppsala	¹³⁷ Cs	(1)	24 ± 11	6.4 ± 1.0	ref. 3
30	Uppsala	¹³⁷ Cs	(1)	24 ± 11	6.1 ± 0.8	ref. 3
31	Uppsala	¹³⁷ Cs	(1),(3) ^(d)	24 ± 11	7.9 ± 3.9	ref. 3
32	Uppsala	¹³⁷ Cs	(1)	24 ± 11	7.6 ± 1.1	ref. 3
33	Uppsala	¹³⁷ Cs	(1)	24 ± 11	8.6 ± 1.1	ref. 3
34	Uppsala	¹³⁷ Cs	(1)	24 ± 11	6.5 ± 1.3	ref. 3
35	Uppsala	¹³⁷ Cs	(1)	24 ± 11	6.3 ± 0.8	ref. 3
36	Grangeneuve	¹³⁷ Cs	- ^(e)	- ^(b)	6.3 ± 1.4	ref. 7
37	Grangeneuve	¹³⁷ Cs	- ^(e)	- ^(b)	3.2 ± 0.5	ref. 7
38	Neuherberg	¹³⁷ Cs	(3)	- ^(b)	- ^(f)	ref. 9
39	Neuherberg	¹³⁷ Cs	(3)	- ^(b)	4.1 ± 1.1	ref. 9
40	Neuherberg	¹³⁷ Cs	(3)	- ^(b)	3.0 ± 0.2	ref. 9
41	Saclay	¹³⁷ Cs	(3)	- ^(b)	10.7 ± 1.1	ref. 4

(continued on next page)

Tab. 1 : (continued)

Data-set no.	Site	Nuclide	Model structure ^(a)	$t_{1/2}^w$ [d]	TF [10^{-3} d/ℓ]	
42	Saclay	^{137}Cs	(3)	- ^(b)	10.0 ± 1.0	ref. 4
43	Trawsgoed	^{137}Cs	(3)	- ^(b)	4.6 ± 0.1	ref. 5
44	Trawsgoed	^{137}Cs	(3)	- ^(b)	6.4 ± 1.4	ref. 5
45	Chester	^{131}I	- ^(g)	7.5 ± 1.1	1.2 ± 0.2	ref. 2
46	Tranvik	^{131}I	- ^(g)	4.5 ± 1.1	1.4 ± 0.2	ref. 1
47	Berlin	^{131}I	- ^(g)	8.7 ± 1.1 ^(h)	6.5 ± 0.3	ref. 1
48	Tokai	^{131}I	- ^(g)	12.2 ± 5.6	4.3 ± 0.5	ref. 1
49	Mariensee	^{131}I	- ^(g)	13.3 ± 4.8	2.2 ± 0.3	ref. 10
50	Bonn	^{131}I	- ^(g)	9.8 ± 1.6	4.6 ± 1.1	ref. 11
51	Russy	^{131}I	- ^(g)	4.5 ± 1.0	3.5 ± 0.9	ref. 8
52	Guschelmuth	^{131}I	- ^(g)	3.6 ± 0.2	2.0 ± 0.4	ref. 8
53	Cumbria	^{131}I	- ^(g)	6.8 ± 1.7	2.7 ± 0.1	ref. 6
54	Faulensee	^{131}I	- ^(g)	5.8 ± 0.7 ^(k)	2.6 ± 0.3	ref. 13
55	Tranvik	^{137}Cs	- ^(g)	8.7 ± 1.3	8.6 ± 1.2	ref. 1
56	Berlin	^{137}Cs	- ^(g)	8.7 ± 1.2 ^(h)	8.3 ± 0.7 ⁽ⁱ⁾	ref. 1
57	Mariensee	^{137}Cs	- ^(g)	11.2 ± 1.0 ^(j)	3.0 ± 0.4	ref. 10
58	Bonn	^{137}Cs	- ^(g)	16.6 ± 4.3 ^(c)	3.1 ± 0.7	ref. 11
59	Cumbria	^{137}Cs	- ^(g)	7.1 ± 0.5	4.8 ± 0.2	ref. 6
60	Faulensee	^{137}Cs	- ^(g)	12.9 ± 2.2 ^(k)	3.5 ± 0.3	ref. 13
61	Petten	^{137}Cs	- ^(g)	- ^(b)	2.9 ± 0.8	ref. 14
62	Petten	^{131}I	- ^(g)	- ^(b)	8.5 ± 6.2	ref. 15

^(a) see Figure 1

^(b) experiments using fodder with constant activity concentrations

^(c) mean half-life assuming model (2a)

^(d) based on the Akaike information criterion ²¹, no decision is possible between the two model candidates

^(e) model identification not possible as animal had incorporated Cs prior to the feeding experiment

^(f) statistical uncertainty of 3-compartment-model > 100 %

^(g) model identification not possible as milk samples were mixed from various cows ¹⁶

^(h) mean of the pasture vegetations used as feed

⁽ⁱ⁾ milk data until day 37 taken into account

^(j) grass data until day 45 taken into account

^(k) 1st cut

Acknowledgement The author is very grateful to all those who made available their original experimental data.

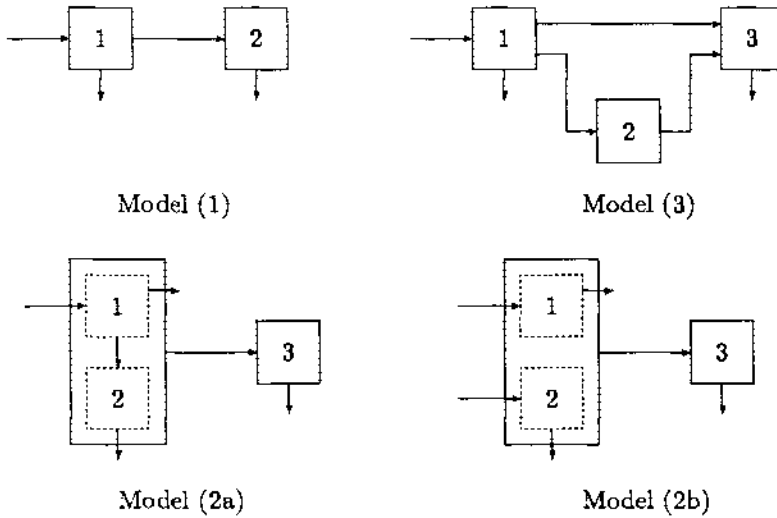

Fig. 1 : Structures of compartmental systems compatible with the experimental data

REFERENCES

1. Köhler, H. et al. (Eds.); BIOMOVS Technical Report 13. Stockholm (1991)
2. Dreicer, M., C.S. Klusek; *J. Environ. Radioact.*, **7**, 201-207 (1988)
3. Bertilsson, J. et al.; *Health Phys.*, **55**, 855-862 (1988)
4. Daburon, F. et al.; *Sci. Total Environ.*, **85**, 253-261 (1989)
5. Mitchell, N.G. et al.; *Sci. Total Environ.*, **85**, 307-316 (1989)
6. Wilkins, B.T., E.J. Bradley; *Sci. Total Environ.*, **68**, 161-172 (1988)
7. Völkle, H. et al.; in: Proc. XVth Regional Congress of IRPA. Verlag TÜV Rheinland, Köln, 262-267 (1989)
8. Surbeck, H. et al.; in: Proc. Symp., Bern, 22.-26. 10. 1986, Bundesamt für Gesundheitswesen, Bern, 411-413
9. Voigt, G. et al.; *Health Phys.*, **57**, 967-973 (1989)
10. Handl, J., A. Pfau; *Atomkernenergie-Kerntechnik*, **49**, 171-173 (1987)
11. Clooth, G., D.C. Aumann; *J. Environ. Radioact.*, **12**, 97-119 (1990)
12. Kirchner, G.; in: Proc. XVth Regional Congress of IRPA. Verlag TÜV Rheinland, Köln, 196-201 (1989)
13. Schmid, E. et al.; in: Proc. Symp., Bern, 22.-26. 10. 1986, Bundesamt für Gesundheitswesen, Bern, 353-379
14. Voors, P.I., A.W. van Weers; *Sci. Total Environ.*, **85**, 179-188 (1989)
15. Voors, P.I., A.W. van Weers; *J. Environ. Radioact.*, **13**, 125-140 (1991)
16. Kirchner, G.; *Modelling of Geo-Biosphere Processes* (in press)
17. Lengemann, F.W. et al.; in: Larson, B.L., V.R. Smith (Eds.): *Lactation*. Vol. 3; Academic Press, New York, 159-215 (1974)
18. Glass, H.I, A.C. de Garreta; *Phys. Med. Biol.*, **16**, 119-130 (1971)
19. Miller, C.W., F.O. Hoffman; *Health Phys.*, **45**, 731-744 (1983)
20. Hoffman, F.O.; in: NUREG/CR-1004, 64-79 (1979)
21. Cobelli, C., A. Ruggeri; *Med. & Biol. Eng. & Comput.*, **20**, 444-450 (1982)

CHERNOBYL: A CONTRIBUTION TO OUR LEARNING PROCESS

O. Ilari and C. Viktorsson

Organisation for Economic Co-operation and Development
Paris, France

The Chernobyl accident and its widespread impact have prompted a process of critical review and revision of approaches to the management of accidents that has fully involved the international community. The OECD/NEA has participated to this effort by analysing the lessons learned from the accident and contributing guidance for a fresh approach to the protection of the public in the event of a nuclear accident.

INTRODUCTION

One of the main driving forces to achieve progress in our society is learning from experience. This is true in improving radiation protection as it is in any other human undertaking. Although this is unfortunate, we must accept that accidents and malfunctions are one of the most powerful sources of experience and, in this respect, the Chernobyl accident, in 1986, has triggered, and still continues to stimulate, one of the most wide-ranging learning processes ever experienced in radiation protection, in areas such as accident consequence assessment and management, emergency preparedness, radioecology and the like. In effect, before Chernobyl the attitude of national authorities and radiation protection operators was one of relative self-confidence with respect to the validity and effectiveness of international guidance and of national preparedness for the protection of the public in the event of nuclear accidents.

The reality of a major accident as the Chernobyl one did, however, show that the degree of preparedness to manage the consequences of an accident of that size was not satisfactory. In fact, although the radiological impact in countries other than the Soviet Union was not large, the progressive spread of contamination at large distances caused considerable concern in Member countries. The reactions of national authorities were varied, ranging from a simple intensification of the normal environmental monitoring programmes up to compulsory restrictions on the marketing and consumption of food and other measures directly affecting the public. This apparent disharmony of protective actions and intervention levels caused concern and confusion among the public, perplexities among the experts and difficulties to national authorities, including loss of public credibility. All this resulted in a widespread perception that several lessons should be learned from this negative experience and a consensus that efforts should be directed towards a better international harmonization of the scientific bases and co-ordination of criteria and measures for the protection of the public in case of emergency.

These conclusions have triggered a vast effort of improvement of emergency planning arrangements in almost all Member countries, but also a renewed attempt by several international organisations to apply the Chernobyl lesson to the rationalisation of principles and criteria and the enhancement of harmonisation and co-ordination of their practical application to the management of nuclear accidents.

THE ROLE OF THE NEA

The NEA, through its Committee on Radiation Protection and Public Health (CRPPH), has played an active role in this process assisting Member countries to identify the main lessons to be learned from the accident and promoting a number of co-operative actions to transform these lessons into improved accident management concepts and procedures.

The CRPPH felt that a first step for establishing where the Agency's effort should be applied was to make an independent assessment of the radiological impact of the Chernobyl accident and a critical review of the consequent emergency responses adopted by the different countries. The Agency, therefore, prepared a first report, published in 1987 (1), which analysed in some detail the radiological impact in all the OECD countries and the protection measures adopted by those countries. This analysis, of course, had a preliminary character in view of the provisional data available at the time, but it still remains today the only assessment established on the basis of information provided by the Member countries and officially endorsed by the national authorities concerned. The NEA also carried out, at that time, a detailed survey of the organisational and technical aspects of the emergency preparedness existing in the Member countries at the time of the Chernobyl accident, as well as of the changes introduced or planned as a consequence of that accident (2). These analyses allowed to identify the principal concerns of the authorities and the public opinion in the different countries.

The first conclusion that could be drawn from these analyses was of a conceptual nature. It was realised that the impact of a major nuclear accident would inevitably have an international dimension and it would require, therefore, a closer harmonization of the intervention criteria beyond the mere harmony of the general principles, which was already existing, as well as an extension of the space and time horizons on which to base the emergency plans, by adding to it elements of greater flexibility and a capability to manage contaminations affecting large territories, and with consequences extending over long time spans. Another important conclusion of the CRPPH analyses was the need to improve the technical systems used for the assessment of the radiological impact of an accident, such as monitoring methods and network systems for rapid alarm and real time assessments, calculation models and analysis methods. Finally, the failures of the systems of communication and information have been one of the major objects of blame during and after the Chernobyl accident. This lesson was not missed and it resulted in a considerable attention being focused on the need to improve the quality and the effectiveness of the communication of information in case of emergency among competent authorities and towards the public.

A significant part of the problems identified by the CRPPH were clearly the responsibility of the national authorities. However, the Committee was able to identify a few areas where the Agency could provide a contribution compatible with its vocation and its limited resources.

The intervention criteria

The first priority was attributed to the question of criteria and levels for intervention. The existing international recommendations, although their general principles were valid, had demonstrated their limitations during the practical management of the Chernobyl accident

consequences at large distances and in the long term. Thus, starting from a critical analysis of the existing recommendations, a group of experts of the Agency examined all the aspects of the intervention issue and developed a number of novel ideas on the determination of criteria and levels for intervention and their practical implementation (3, 4). In particular, the NEA group proposed a reasonably detailed approach for the application of the principles of justification and optimisation of interventions in the definition of the intervention levels and introduced the concepts of "upper boundary" and "lower boundary" of individual dose in the process of optimisation.

A particularly interesting concept is that of upper boundary, defined as the total individual dose, resulting from the whole of exposure pathways, beyond which the possibility of deterministic effects and the probability of stochastic effects are considered unacceptable. Beyond the upper boundary the intervention would thus become mandatory irrespective of the indications provided by the results of the justification and optimisation procedures. The validity of this idea was confirmed by a widespread demand for a criterion of this kind which had been expressed on several occasions in the international debate. The concept of lower boundary, a very small individual dose below which protective actions are unlikely to be justified even if the costs of the intervention are also very small, was also considered very useful and necessary by many experts. However, this concept does not appear to have been well received in the recommendations of other international organisations. Another original contribution introduced by the NEA was the consideration, which was absent in the previous international guidance, of the impact of certain special exposure pathways affecting specific groups, such as workers not involved in emergency operations, and the definition of specific protection criteria for these groups.

The technical issues

In the field of the technical aspects of emergency planning, the NEA has chosen to limit itself to the study of a few issues which had not attracted the attention of other international organisations. First of all, an analysis was made of the possible differences in the radiological consequences of an accident if this were to happen in different seasonal and climatic conditions and how these factors could affect the application of emergency plans (5,6).

The Chernobyl experience was also the indirect source of another initiative recently taken by the NEA in the field of emergency exercises, which, surprisingly, had never enjoyed before a particular attention at the international level. A work programme is currently under way for an exchange of information and experience on national practices, the study of criteria and technical methods for the execution of emergency exercises and, as a final step, the organisation of international exercises under the NEA's aegis. Multinational or international emergency exercises are, in fact, seen as being of particular value to test the compatibility and co-ordination of neighboring countries' approaches to emergency planning by the simulation of scenarios which extend beyond national borders and to contribute to better mutual understanding and, possibly, closer harmonization of the basic approaches to emergency response on a truly international basis.

The communication with the public

Last but not least, it was understood with the Chernobyl accident that the communication between countries and with the public is a fundamental component of a correct management of a nuclear accident, especially if it has an international impact. The information of the public is not the main vocation of the NEA, which is primarily a technical agency. However, it was decided to bring some contribution to those who are responsible for the information of the public and several initiatives were taken by the Agency in this field.

One interesting idea that began to be aired in 1987 was that of creating an international system for the classification of incidents and accidents according to their degree of severity, and impact to safety, to be used to facilitate the information of the public. At the end of 1987, a group of experts of the NEA had already set up a series of criteria for the development of what would have been called since the international severity scale for nuclear accidents and incidents. Subsequently, in 1989, the NEA and the IAEA decided to join their forces in this international undertaking and launched jointly, in 1990, the International Nuclear Event Scale (INES), which was adopted by a large number of member countries for a trial period before its final establishment on a permanent basis. A success of this endeavour would mean a significant step towards a better coherence and clarity in the communication with the public.

CONCLUSION

In conclusion, the Chernobyl accident has revealed a number of weaknesses in the protection system such as it was conceived before the accident, but it has also indicated new perspectives for improvement. In this context, in which the international co-operation has played a major role, the NEA has tried to draw a maximum of lessons which could be useful to its Member countries and to provide, within the limits of its modest resources, an active contribution to the international co-operation and the improvement of radiation protection.

REFERENCES

1. Nuclear Energy Agency, 1987, The Radiological Impact of the Chernobyl Accident in OECD Countries, OECD, Paris.
2. Nuclear Energy Agency, 1988, Emergency Planning Practices and Criteria After the Chernobyl Accident: A Critical Review, OECD, Paris.
3. Nuclear Energy Agency, 1989, Nuclear Accidents: Intervention Levels for the Protection of the Public, OECD, Paris.
4. Nuclear Energy Agency, 1990, Protection of the Population in the Event of a Nuclear Accident: A Basis for Intervention, OECD, Paris.
5. Nuclear Energy Agency, 1989, The Influence of Seasonal Conditions on the Radiological Consequences of a Nuclear Accident, Proceedings of an NEA Workshop, OECD, Paris.
6. Nuclear Energy Agency, 1991, Influence of Seasonal and Meteorological Factors on Nuclear Emergency Planning, OECD, Paris.

RESULTS OF THE IAEA WHOLE BODY COUNTING PROGRAMME IN THE
SOVIET UNION

R.V. Griffith, R. Ouvrard, R. Hartmann and R. Hochmann

International Atomic Energy Agency
Vienna, Austria

F. Steger

Austrian Research Centre
Seibersdorf, Austria

ABSTRACT

In 1990, the IAEA conducted a whole body counting programme in the Soviet Union as part of its project on The Radiological Consequences in the USSR from the Chernobyl Accident: Assessment of Health and Environmental Effects and Evaluation of Protective Measures. Approximately 9,000 people from 9 towns in three republics were counted to corroborate measurements of internal ¹³⁷Cs contamination in the effected population made by the Soviet specialists following the accident. A mobile whole body counting facility, equipped with 4 chair counters was loaned to the Agency by the SCPRI, France for use in the measurement programme.

INTRODUCTION

As part of the IAEA international assessment programme carried out in 1990-91, a project was implemented by the IAEA to provide independent measurements of the internal doses currently received by individuals in 9 selected settlements in the USSR [1]. During the period 5 July to 7 September 1990 a whole body counting campaign was conducted in the BSSR, RSFSR and UkrSSR, using a mobile whole body counting van provided by the SCPRI, France. Nearly 10,000 total measurements were made including reference measurements of a calibration phantom, as well as of van staff, for quality control. The results for 9,058 people are reported here.

COUNTING PROCEDURE

The mobile van is equipped with four chair counters. Each counter has a 7.62 × 7.62 cm cylindrical NaI crystal housed in a collimated lead shield. The person is positioned for counting so that the shield is centered on the chest, over the region of the lungs, and in contact with the body. The counting period was 5 minutes. The background rates for the counters were determined by inserting a conical plastic plug into the collimator.

During counting, the person being measured provided some self shielding, thus reducing the counter background. Unfortunately, the degree of self shielding was variable, depending on the mass of the person. This is a particularly a problem in evaluating results for small children. Since the counting procedure as established by SCPRI was intended to be used for adults, it did not make provision for corrections based on wide variations in body mass.

The data were processed with a multichannel analyzer and a portable computer using software developed at SCPRI. The SCPRI data-unfolding process is intended to accommodate up to three radionuclides. However, the counting statistics were often poor, so only results for ^{137}Cs are presented in this report. From information provided by whole body counting specialists in Kiev and Minsk, based on their counting results, the ratio of ^{137}Cs to ^{134}Cs was approximately 6.5. Results of this ratio for an environmental sample, dried green peas grown in the Chernobyl region and assayed in December 1990, ranged from 7.9 to 8.8. This would be equivalent to 7.2 in August 1990, the mid-point of the whole body counting project.

The limit of detection (LOD) as defined by the data-processing software of the mobile van is three times the background count standard deviation. Because of the high variability in background from one town to another, the LOD is variable. In addition, the efficiency depends significantly on the size of the person being counted. Therefore, a single value cannot be quoted. However, a typical LOD for an adult is about 0.74 kBq (0.02 μCi), while for a small child the value drops to about 0.19 kBq (0.005 μCi).

COUNTER CALIBRATION

Since the mobile van was designed for operational emergency response applications, the calibration is based on a 70-kg reference man, 170 cm tall. The design of the counters in the counting van is such that only activity in the torso is detected. For adults this means that the mass of tissue seen by the counter is roughly constant. Following a review of the counting procedure, it was concluded that the calibration was reasonably accurate in the weight range 50 to 90 kg. However, for individuals outside that range the results could be significantly in error. For a child weighing 20 kg with a height of 100 cm, for example, the original calibration would overestimate the caesium burden by a factor of 2.6. Therefore, it was recommended that a modified correction factor based only on weight be used:

$$CF = \frac{70}{\text{Weight (kg)}} \quad (1)$$

During the measurement programme, a plastic cylindrical phantom containing ^{137}Cs was used to check the counter performance on a daily basis. In addition, a few members of the van staff had measurable levels of ^{137}Cs . They were also counted at regular intervals.

At the end of the counting programme, the van returned to Seibersdorf. At that time, the calibration of each counter was checked with a standard bottle phantom obtained from the Battelle Pacific Northwest Laboratory in the USA. The phantom contained 11.2 kBq ^{137}Cs in a solid polyurethane tissue substitute.

RESULTS

Summary statistics and internal dosimetry results for the nine settlements in the BSSR, RSFSR and UkrSSR are presented in Table 1. Since the measurements were made at only one time, it is impossible to determine time dependent changes in the internal body levels. Therefore, a constant intake was assumed. A conversion factor for specific body burden to dose rate of 2.5 $\mu\text{Sv/a}$ per Bq/kg was used to calculate annual dose.

The results for a given population can be expected to have a log normal distribution. The distribution of specific body burdens for the settlement of Novozybkov, the largest population counted is shown in Figure 1, with an estimate of the best fit for a log normal distribution. The quality of fit varies from village to village. In some cases, non-statistical factors influence the results. For example, the assignment of the value of the detection limit to those measurements at or below that limit obviously biases the low activity results upwards.

This effect can be seen more clearly in the cumulative normal probability plots of the log of the specific body burden. The overlying straight line represents the distribution that would be expected for a population having a log normal distribution without additional influences. These plots also demonstrate deviation from the expected distribution at higher values of the specific body burden. The reason for this deviation has not been definitely identified. A possible explanation is that it is the result of a small subset of the population that does not observe the dietary restrictions imposed by local authorities, or that dietary habits (such as eating large quantities of forest mushrooms) predispose members of the population to higher body burdens.

REFERENCES

1. International Advisory Committee, 1991, The International Chernobyl Project: Assessment of Radiological Consequences and Evaluation of Protective Measures, Technical Report, IAEA, Vienna

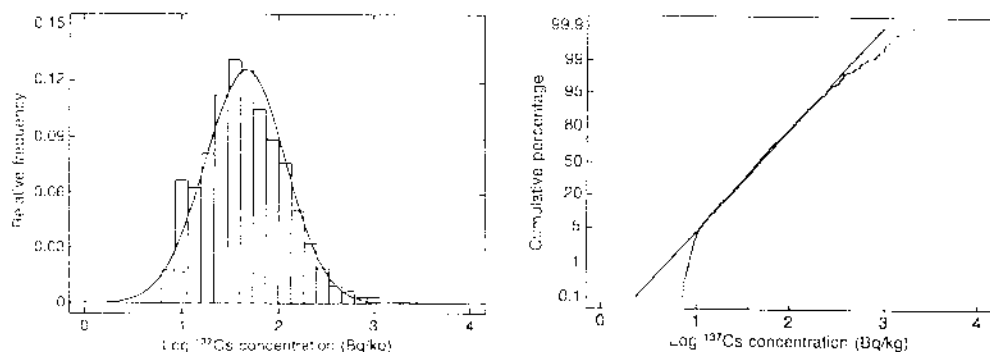

Fig. 1: Relative frequency and log-normal probability distributions for the Novozybkov population sample (1455 people)

Table 1 - IAEA, USSR whole body counting project results summary

Settlement	Statistical quantity	Weight (kg)	Age (years)	¹³⁷ Cs specific body burden (Bq/kg)	Annual dose based on specific body burden (mSv)
BYELORUSSIA					
Bragin <i>Population</i> <i>sample:</i> 1154	Average	71.5	40.1	44.4	0.11
	Median	73	39	32.1	0.08
	Standard Dev.	19.5	17.6	90.5	0.23
	Maximum	135	89	2110	5.3
Veprin <i>Population</i> <i>sample:</i> 1064	Average	64.6	36.5	46.7	0.12
	Median	69	38	24.2	0.06
	Standard Dev.	22.7	20.0	78.1	0.20
	Maximum	125	86	1370	3.4
Kur'ma <i>Population</i> <i>sample:</i> 719	Average	67.6	38.5	50.6	0.13
	Median	70	38	36.4	0.09
	Standard Dev.	22.3	19.2	66.5	0.17
	Maximum	118	85	933	2.3
RUSSIAN REPUBLIC					
Novozybkov <i>Population</i> <i>sample:</i> 1455	Average	69.3	40.4	78.0	0.20
	Median	72	42	43.4	0.11
	Standard Dev.	20.1	17.7	131	0.33
	Maximum	130	85	2200	5.50
Zlycka <i>Population</i> <i>sample:</i> 998	Average	66.7	38.7	116	0.29
	Median	70	39	67	0.17
	Standard Dev.	21	19.3	172	0.43
	Maximum	120	96	1990	5.0
UKRAINE					
Dakta <i>Population</i> <i>sample:</i> 194	Average	55.8	22.0	396	0.99
	Median	55	16	279	0.70
	Standard Dev.	25.2	16.4	425	1.1
	Maximum	115	67	3750	9.4
Ovruch <i>Population</i> <i>sample:</i> 1153	Average	69.3	38.6	185	0.46
	Median	72	42	77.9	0.20
	Standard Dev.	20.9	16.9	353	0.89
	Maximum	130	80	4060	10
Poleskoc <i>Population</i> <i>sample:</i> 1003	Average	73.9	36.8	76.2	0.19
	Median	75	36	29.9	0.08
	Standard Dev.	19.8	15.8	158	40
	Maximum	140	76	1960	4.9
Rakitnoe <i>Population</i> <i>sample:</i> 1320	Average	67.1	33.9	144	0.36
	Median	70	35	77	0.19
	Standard Dev.	20.1	15.6	203	0.51
	Maximum	120	76	2524	6.30

SUR LES RETOMBÉES MONDIALES DE L'ACCIDENT DE TCHERNOBYL

A.DOURY

CEA-IPSN

Département d'Evaluation de Sécurité
Fontenay-aux-Roses

ON THE WORLDWIDE FALLOUT FROM THE CHERNOBYL ACCIDENT

ABSTRACT

Numerous measurement's results of cesium 137 deposition from the Chernobyl accident were gathered and they were compared with a modelling which is simplified and adapted to the long distances. The figure shows a good agreement between measurements and model. It shows also that the radiological impact of the accident, lesser beyond 2000 km than that of all nuclear weapons tests, or lesser than that of one year of natural radioactivity, diminish strongly with the distance from the place of the accident. Some very small cesium 134 detections in the south hemisphere can be easily related to the Chernobyl accident.

INTRODUCTION

Grâce à des simplifications convenables, il est possible de montrer clairement que la distribution mondiale des retombées radioactives observées de l'accident de Tchernobyl est en accord satisfaisant avec une modélisation classique, et que l'essentiel des conséquences radiologiques en est connu et à l'abri de toute contestation.

LES PARAMETRES DE LA MODÉLISATION

Même simplifiée et mondiale toute modélisation des retombées d'une pollution telle que celle due à cet accident dépend de quelques paramètres déterminants qui concernent l'émission, l'éloignement, la diffusion, les dépôts secs et précipités et la remise en suspension. Emission mise à part ces paramètres participent à la déconcentration des nuages de polluants, les plus efficaces étant ceux des dépôts, qui appauvrissent les nuages, surtout après le premier millier de kilomètres.

UNE MODÉLISATION SIMPLIFIÉE

Pour simplifier la modélisation on a remplacé les émissions réelles par une émission unique ponctuelle instantanée et les trajectoires réelles, d'ailleurs mal connues, par une trajectoire unique de plus courte distance ou de plus court délai pour chaque point d'observation. Ces hypothèses sont toutes majorantes pour les concentrations maximales. Le traitement de la diffusion par la turbulence de l'atmosphère est classique et comporte notamment une épaisseur de mélange constante de 1000 mètres. Le dépôt sur les surfaces et la remise en suspension sont traités par les coefficients

habituels dont les valeurs sont tirées de la bibliographie. Au delà de 2000 km, la correction d'appauvrissement des nuages par le dépôt, dite "à la source", conduit à des appauvrissements exagérés et doit être amendée en conséquence.

LES RÉSULTATS EXPRIMÉS EN DÉPÔT DE CÉSIUM 137

De très nombreux résultats d'observation et de mesure, provenant de presque toutes les parties du monde, ont pu être rassemblés /1/, /2/, /3/, /4/, /5/, /6/, /7/. Ils sont exprimés en dépôt de césium 137 récent, associé à l'isotope 134, c'est-à-dire provenant avec certitude de l'accident de Tchernobyl. Le césium 137 est en effet, avec sa longue période, un très bon indicateur des transferts à grande distance, et son dépôt une composante essentielle des doses délivrées. Tous ces résultats sont reportés, en Bq/m^{-2} , en fonction de la plus courte distance en kilomètres, ou de la durée de transfert en jours, sur la figure où la modélisation est représentée par trois courbes. La courbe supérieure n'est qu'une indication de l'absence de réalisme d'un calcul sans correction d'appauvrissement du nuage. La courbe inférieure implique une correction d'appauvrissement unique, trop sévère aux grandes distances. La courbe intermédiaire est un ajustement empirique qui implique un appauvrissement moins sévère à partir de 1000 km. Cette troisième courbe sépare le domaine en deux parties telles que toutes les observations doivent se trouver dans la partie inférieure et aucune dans la partie supérieure. Cette modélisation est en effet systématiquement majorante. De plus elle n'est valable que sur une trajectoire et enfin une précipitation intervenant sur une trajectoire ne peut entraîner qu'une majoration supplémentaire maximale d'un facteur de l'ordre de 10.

On voit que l'alignement des observations est satisfaisant et que l'importance de la retombée décroît fortement en fonction de l'éloignement, en raison même de la rétention qu'elle provoque. On voit aussi sur la figure que la retombée totale en césium 137 des essais nucléaires aériens, de l'ordre de 5000 Bq/m^2 et quasi homogène sur l'ensemble de la planète, correspond à celle de l'accident de Tchernobyl à une distance d'environ 2000 km du lieu de l'accident /8/. On sait (UNSCEAR) que l'impact radiologique de l'ensemble des essais nucléaires aériens est de l'ordre de celui d'une année moyenne de radioactivité naturelle.

Plus on s'éloigne du lieu de l'accident plus les hétérogénéités de la retombée ont tendance à s'estomper en raison des dimensions atteintes par les nuages et des recoupements de trajectoires. Mais en même temps on tend vers une faible contamination générale de la planète qui se stabilise momentanément, selon un équilibre du dépôt et de la remise en suspension, autour de valeurs limites inférieures de l'ordre de $1 \mu\text{Bq/m}^3$ dans l'air, et de $0,1 \text{ Bq/m}^2$ en surface, soit pour un coefficient de remise en suspension de l'ordre de 10^{-5} m^{-1} . Ces valeurs limites, qui sont aussi des limites de détection, même pour des laboratoires spécialement équipés, sont de l'ordre de grandeur actuel des résidus de la retombée

des essais nucléaires aériens. Leur appartenance à l'accident de Tchernobyl ne peut être établie qu'en passant par l'isotope 134. Il semble que quelques stations françaises de Polynésie et de l'océan indien aient fourni des prélèvements permettant d'obtenir de telles détections /7/, /9/. Cette circonstance confirmerait l'absence d'effet de barrière de l'équateur sur la diffusion de fines particules transportées par l'atmosphère, même dans les basses couches.

CONCLUSIONS

- 1 - L'accident de Tchernobyl n'apporte pas d'information révolutionnaire de nature à modifier significativement les errements en vigueur en matière de modélisation de la dispersion de polluants atmosphériques.
- 2 - Si l'accident de Tchernobyl est certes un événement tragique pour les populations proches de la Centrale, et si on a pu dire que cet accident était une catastrophe mondiale (média), on ne peut sûrement pas dire qu'il s'agisse d'une catastrophe radiologique mondiale. Son impact radiologique diminue en effet fortement en fonction de l'éloignement, et au delà de 2000 km il est inférieur à celui des essais aériens ainsi qu'à une année moyenne de radioactivité naturelle.
- 3 - Compte tenu des lois connues de la dispersion à l'échelle mondiale, il ne serait pas nécessaire de faire intervenir d'autres sources que celles de Tchernobyl pour expliquer correctement d'éventuelles très rares et très faibles détections de césium 134 dans l'hémisphère Sud.

RÉFÉRENCES

- /1/ - CEA-IPSN, L'accident de Tchernobyl, Rapport IPSN, 2/86, rév. 3, 1986.
- /2/ - US-Department of energy, A compendium of the environmental measurements laboratory's research projects related to the Chernobyl nuclear accident, EML-460, New York, N.Y. 1014, 1986.
- /3/ - UKAEA, Radioactive fallout in air and rain: Results for 1985 and 1986, Harwell laboratory, AERE R 12872, 1988.
- /4/ - UKAEA, Radioactive fallout in air and rain: Results to the end of 1987, Harwell laboratory, AERE R 13226, 1989.
- /5/ - UKAEA, Radioactive fallout in air and rain: Results to the end of 1988, Harwell laboratory, AERE R 13575, 1989.
- /6/ - CAMBRAY R.S. et al., Observations on radioactivity from Chernobyl accident, Nuclear Energy, 26, 2, pp. 77-101, 1987.
- /7/ - République française, CEA, DIRCEN, Surveillance de la radioactivité en 1987.
- /8/ - DOURY A., Evaluation comparative des retombées radioactives de l'accident de Tchernobyl et des essais nucléaires atmosphériques, Radioprotection, 22, 2, pp. 137-160, 1987.
- /9/ - PHILIPPOT J.C., Fallout in snow, Nature, 348, 1, p. 21, 1990.

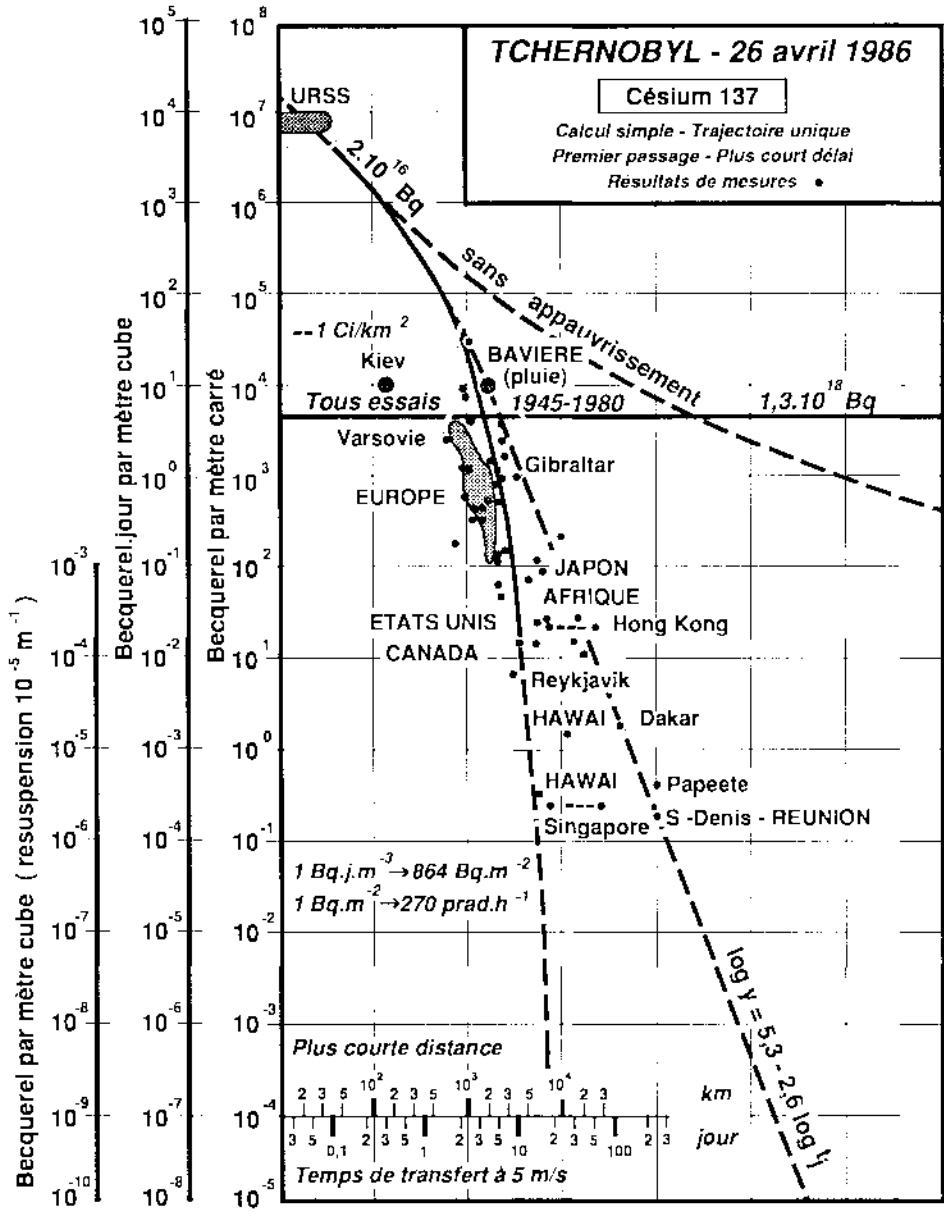

INHALATION OF NONVOLATILE RADIONUCLIDES AFTER THE CHERNOBYL ACCIDENT - A RETROSPECTIVE APPROACH

G. Lindner¹, Ch. Wilhelm¹, S. Kaminski¹, B. Schell¹, M. Wunderer¹ and U. Wahlf²

¹Institut für Innovation und Transfer, Fachhochschule Ravensburg-Weingarten, D-7987 Weingarten, F.R.G.; ²Fakultät für Physik, Universität Konstanz, D-7750 Konstanz, F.R.G.

ABSTRACT

A procedure for estimates of the abundance and size distribution of nuclear fuel particles in the Chernobyl fallout is described, which allows calculations of the inhalation dose due to nonvolatile radionuclides contained therein. These are represented by the gamma-emitter Ce-144. An example is given for the Chernobyl nuclear power plant area based on the autoradiographic analysis of a soil sample and gamma-spectrometric and electron microscopic analysis of isolated fuel particles. At larger distances from Chernobyl the relative importance of nonvolatile radionuclides decreases with distance; it is highest in regions contaminated by the explosion plume as obtained from the Ce 144 to Cs-137 isotopic ratio in the fallout.

INTRODUCTION

The emission and dispersion of micrometer sized nuclear fuel particles due to the explosion of the reactor core is a unique feature of the Chernobyl fallout /1/. Different types of particles have been detected /2-9/. The majority consists of a UO₂ matrix depleted in volatile radionuclides like Cs-137, but retaining refractory radionuclides like Cs-144, Sr-90 or transuranium isotopes, which thus can easily be identified via the long-lived gamma-emitter Ce-144. A typical Ce-144 activity of a 4 µm particle was about 10 Bq at May 1st, 1986. A small fraction is formed from metallic segregations of ruthenium and molybdenum in the fuel; they were characterized by Ru-106 and their activities per particle of equal size were about 1000 times larger. The inhalation of those particles during the passage of radioactive clouds in the initial phase of the accident contribute to the inhalation dose, which depends on the number and size of those particles and which demands for microdosimetric calculations /10/. In this contribution an approach is outlined, which allows a rough estimate of these quantities from the determination of the number and size distribution of fuel particles deposited on the ground assuming Stokesian sinking of these particles in air. It is restricted so far to the more abundant UO₂-type particles.

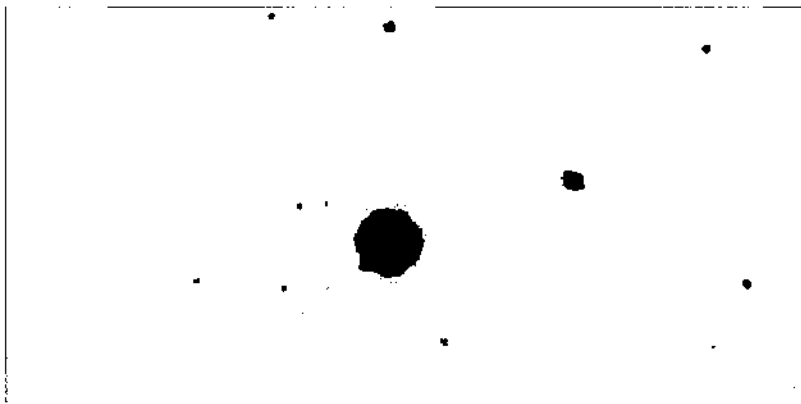

Fig. 1: Autoradiographic exposure of a soil sample taken at the cooling pond of Chernobyl nuclear power plant in September 1990 and exposed in June 1991 (Kodak "Direct Exposure"). The dark spots indicate nuclear fuel particles.

NUMBER AND SIZE DISTRIBUTION OF FUEL PARTICLES IN THE FALLOUT

This analysis is based on a soil sample taken in September 1990 at the western shore of the cooling pond of Chernobyl nuclear power plant (about 4 km distance from unit 4). Via autoradiography a number of fuel particles could be identified in this sample (fig. 1). A few of them could be isolated and analyzed by means of gamma spectrometry and electron microscopy. The predominant Ce-144 line in the respective gamma spectra and the characteristic U X-rays in the corresponding electron probe X-ray analysis proved their UO₂-type character [11]. The size of these particles was estimated from electron microscopical images (fig. 2). Thus a size - activity relation could be established and the activity per particle could be related to the spot size in the autoradiographic exposures, which eventually allows the classification of autoradiographic spots with respect to the corresponding particle activities and sizes (fig. 3). From the autoradiography of fig. 1 ground inventories of at least 10000 particles/m² with diameters < 5 μm and 5000 particles/m² with larger diameters were estimated. A finer classification needs additional autoradiographic exposures and a better understanding of the activity - spot-size relation of the autoradiographic exposures. On the other hand, assuming only particles with 2 μm and 10 μm diameter, respectively, the measured total Ce inventory of the soil sample is reproduced from these figures within a factor 4, which gives the proper order of magnitude.

ESTIMATE OF PARTICLE INHALATION

The following procedure allows estimates of the number and size distributions of inhaled particles: From the particle diameter d obtained from autoradiography the corresponding sinking velocity in air is calculated using Stoke's law, i.e. $v_{\text{dep}} = \frac{d^2 g \rho}{18 \eta}$, η

$1,8 \cdot 10^{-5}$ kg/m² viscosity of air, $\rho = 11$ g/cm³ density of UO₂ particles, and from the inventory n of particles of this size on ground the corresponding time-integrated

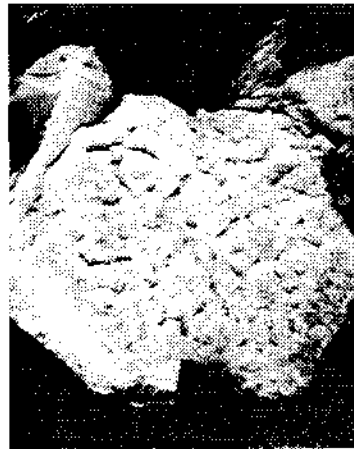

10 μm

Fig. 2: Scanning electron microscope image of a large-size fuel particle isolated from water plants in Kiev reservoir in 1990 (from ref. 11).

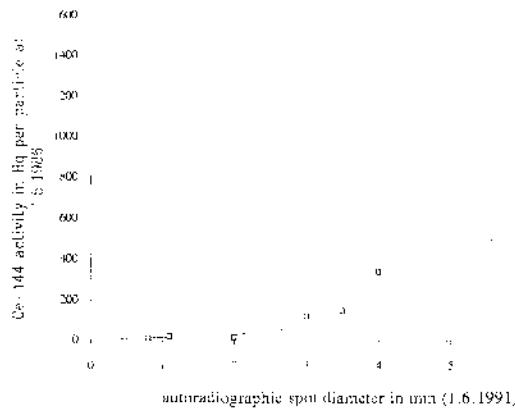

Fig. 3: Relation between Ce-144 activity, corrected for nuclear decay since May 1st, 1986, and corresponding spot diameter of autoradiographic exposures (Kodak "Direct exposure") of fuel particles (fig. 1) produced in June 1991.

particle concentration C in air was obtained from $C = n/v_{dep}$. Multiplying this value with the mean human inhalation rate of $0,7 \text{ m}^3/\text{h}$ results in the number of particles of this size inhaled by a person resting at the site of deposition during the passage of the cloud. Of course any influences of nonuniform particle distributions, turbulent motions and wind drifts are neglected in this oversimplified approach. As an example, the particle distribution at the sampling site shall be represented by $10000 \text{ particles}/\text{m}^3$ with a uniform diameter of $2 \mu\text{m}$, and $5000 \text{ particles}/\text{m}^3$ $10 \mu\text{m}$ in diameter. Then we arrive at deposition velocities of $1,2$ and $30 \text{ mm}/\text{s}$ and numbers of inhaled particles per person of 1600 and 32 , respectively. The total inhaled activities of both groups of particles, on the other hand, are roughly equal, but taking into account the higher retention probability of smaller sized particles in the lung it is presumed that the small-size fraction will cause the more important contribution to the lung dose.

EXTRAPOLATION TO LARGER DISTANCES FROM CHERNOBYL

Beyond, say, 200 km distance the direct determination of particles in soil samples will hardly be possible today due to radioactive decay and decreasing particle diameter with distance. From the rather detailed Cs-137 contamination maps, however, the number distributions of particles can be reconstructed, if reasonable assumptions for the size spectra of particles as a function of distance are made and if the local Ce-144/Cs-137 isotopic ratio in the fallout is known. Fig. 4 shows local Ce-144/Cs-137 isotopic ratios determined so far, which vary with distance and in particular with contamination time: Whereas in the regions contaminated by the first plume produced by the explosion this ratio is particularly high and even exceeds the original core value in the evacuation zone due to volatilization of Cs-137 and preferential deposition of fuel particles (e.g. position 2, from which the soil sample described above is taken), it is rather small e.g. in central Europe contaminated by a plume emerging from the accident site only more than one day after the explosion. Correspondingly both particle sizes and particle numbers are rather small in central Europe, e.g. about $40 \text{ particles}/\text{m}^3$ with particle sizes above $2 \mu\text{m}$ were detected in Konstanz in Southern Germany [5].

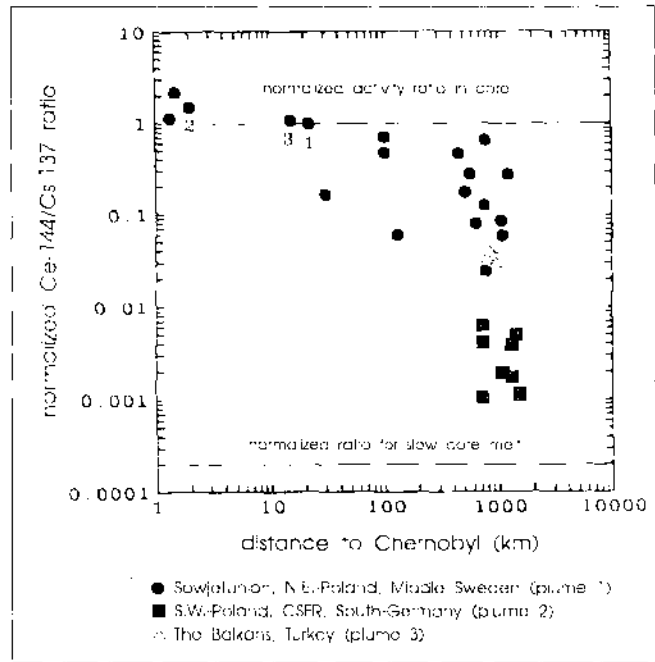

Fig. 4: Isotopic ratio of Ce 144 to Cs 137, normalized to the respective ratio in the reactor core prior to the explosion and corrected for nuclear decay since April 26th, 1986, for soil samples from different sites in Europe. Samples from areas contaminated by the same plume are characterized with the same symbols. Sample no. 2 was used for the investigations reported above.

CONCLUSION

Inhalation of nuclear fuel particles from the Chernobyl fallout containing nonvolatile radionuclides is only a minor contribution to inhalation dose outside USSR. Near the accident site, however, this contribution may become important and a microdosimetric approach seems to be appropriate for dose estimates. A procedure for the reconstruction of the number and size distributions of inhaled particles from measurements of deposition densities of these particles and their sizes using autoradiographic, gamma spectrometric and electron microscopic techniques is described. Considerable efforts with respect to representative determinations of the ground inventories of these particles and to a reconstruction of their transport in air are necessary, however, for reliable dose calculations.

The help of the Integrated Radioecological Expedition of USSR Academy of Sciences and of H.-J. Schodlock in sampling and support from German Research Foundation for travelling are gratefully acknowledged.

REFERENCES:

- /1/ I. Devell, H. Tovedal, U. Bergström, A. Appelgren, J. Chyssler, L. Andersson: "Initial Observations of Fallout from the Reactor Accident at Chernobyl", *Nature* 321, 1986, p. 192-193.
- /2/ R. Broda: "Gamma Spectroscopy Analysis of Hot Particles from the Chernobyl Fallout", *Acta Physica Polonica* B18, 1987, p. 935-950.
- /3/ P. Schubert and U. Behrend: "Investigations of Radioactive Particles from the Chernobyl Fallout", *Radiochimica Acta* 41, 1987, p. 149-155.
- /4/ L. Devell: "Nuclide Composition of Chernobyl Hot Particles", Report Studsvik (NP 87/119), Nyköping, 1987.
- /5/ U. Wahl, G. Lindner und E. Recknagel: "Radioaktive Partikel im Tschernobyl-Fallout", in W. Köhnlein, H. Traut und N. Fischer (Hrsg.): "Die Wirkung niedriger Strahlendosen - biologische und medizinische Aspekte", Springer, Berlin-Heidelberg, 1988, p. 165-176.
- /6/ R.G. Cuddihy, G.L. Finch, G.J. Newton, F.F. Hahn, J.A. Mewhinney, S.J. Rothenberg and D.A. Powers: "Characteristics of Radioactive Particles Released from the Chernobyl Nuclear Reactor", *Environ. Sci. Technol.* 23, 1989, p. 89-95.
- /7/ H. Saari, S. Luokkanen, M. Kulmala, S. Lehtinen and T. Raunemaa: "Isolation and Characterization of Hot Particles from Chernobyl Fallout in Southwest Finland", *Health Physics* 57, 1989, p. 975-984.
- /8/ N.A. Loshchilov, V.A. Kashparov, E.B. Yudin, V.P. Protsak, M.A. Zhurba, Yu.A. Ivanov and A.E. Parshakov: "Physical-Chemical Forms of Chernobyl's Fall-out", in Proc. Meeting "The Radiobiological Impact of Hot Beta Particles from the Chernobyl Fall-out - Risk Assessment", Ukrainian Institute of Agricultural Radiology, Kiev, 1991.
- /9/ V.V. Demchuk, O.V. Voytsekhovich, V.A. Kashparov, N.V. Viktorova and G.V. Laptev: "Analysis of Chernobyl Fuel Particles and their Migration Characteristics in Water and Soil", Proc. Sem. "Comparative Assessment of the Environmental Impact of Radionuclides Released during Three Major Nuclear Accidents: Kyshtym, Windscale, Chernobyl", Commission of the European Communities, Luxembourg, 1991, p. 493-513.
- /10/ W. Burkart: "Radiation Biology of the Lung", *Sci. Tot. Environm.* 89, 1989, p. 1-230.
- /11/ G. Lindner, S. Kaminski, B. Schell, H. J. Schodlock, U. Wahl und Ch. Wilhelm: "Verteilung von schwerflüchtigen Radionukliden mit dem Fallout vom Kernreaktor-Unfall in Tschernobyl", in H. Jacobs und H. Bonka (Hrsg.): "Strahlenschutz für Mensch und Umwelt", Verlag TÜV Rheinland, Köln, 1991, p. 259-264.

U.S. DEPARTMENT OF ENERGY CHERNOBYL DATABASES

R.A. Kennedy, J.A. Mahaffey, S.K. Smith, and F. Carr, Jr.

Pacific Northwest Laboratory
Richland, WA, USA

ABSTRACT

The Chernobyl Database project is developing and maintaining an information system to provide researchers with data and resource materials relating to the Chernobyl nuclear accident of April, 1986. The system is the official United States repository for Chernobyl data. The system includes a collection of Chernobyl-related documents, a database of bibliographic references, and a collection of radiological measurements records. In addition, products have been developed to make the resources more accessible and easy to use. These products include a personal-computer-based bibliographic search system (*ChernoLit*¹), two printed bibliographies, and a personal-computer-based radiological measurements database system (*ChernoDat*).

BACKGROUND

Initial studies of the Chernobyl accident were conducted under emergency conditions with primary attention directed toward characterizing the immediate potential hazard to the human population in various parts of the world. Since the emergency passed, efforts have been redirected toward long-term research to investigate health and environmental consequences of the accident. Use of data collected during and after the emergency presents an opportunity to evaluate historical risk, transport, and deposition models previously based on laboratory experiments, theoretical calculations, and simulated accidents, with limited real measurement data. Thus, Pacific Northwest Laboratory (PNL) was designated by the U.S. Department of Energy (DOE) as the official U.S. repository for information related to the Chernobyl accident and was chartered to generate products that facilitate research. These products include the printed bibliographies as well as the *ChernoLit* and *ChernoDat* software packages.

Developing the Chernobyl information system has been challenging for at least four reasons. First, no formal agreements exist to provide data from the accident to our information system. Organizations must be identified, contacted, and asked to share their data. Second, there is no standardized approach to measurement recording; information is reported with varying levels of detail and summarization. Often,

¹ *ChernoLit* is a trademark of Battelle Memorial Institute, Columbus, OH, USA.

measurement data and reports from the same agency have varying content and format. Third, supporting information was not (and possibly could not) be collected during the emergency-response period. These items include precise measurement locations, data quality information, background levels, and equipment used for collection and analysis. Fourth, specific uses and users of the Chernobyl information system were not identified, and requests for information vary tremendously.

CHERNOLIT

The Chernobyl Bibliographic Search System (*ChernoLit*) provides bibliographic data in a usable format for research studies relating to the Chernobyl accident. *ChernoLit* is a portable and easy-to-use product that includes search capabilities on bibliographic data. The user may specify names, words, and phrases of interest. These search criteria may be logically compounded. The user may also specify which database fields are to be searched. The user may interactively view the references, including the abstracts, or may generate a report. Reports may be directed to the screen, to the default printer, or accumulated in a folder that is written to a disk file when the user exits *ChernoLit*.

ChernoLit runs on an IBM² PS/2, AT, or fully-IBM-compatible computer configured with either a 5-1/4 inch or 3-1/2 inch high density floppy disk drive. A minimum of 8 megabytes of free disk space is necessary to execute the software. An operating system of DOS 3.3 or higher is required. For best performance, use of a mouse is recommended. If printed reports are desired, a printer must be available to the computer.

ChernoLit has been implemented as a FoxPro³ 2.0 run-time application consisting of pull-down menus, shortcut keys, text buttons, and dialog boxes as well as the bibliographic database. This stand-alone system is provided in compressed format on floppy disks. An automatic install procedure loads the application onto the user's computer. A version that executes on the Macintosh⁴ computer will be available in the future.

Over 4400 references concerning the accident, complete with abstracts, are included in *ChernoLit*. The data contained in

² IBM, PS/2, and AT are trademarks of International Business Machines Corporation, Boca Raton, FL, USA.

³ FoxPro is a trademark of Fox Software, Inc., Perrysburg, OH, USA.

⁴ Macintosh is a registered trademark of Apple Computers, Inc., Cupertino, CA, USA.

the database was obtained from three electronic literature searches and from requested donations from individuals and organizations. These literature searches, conducted in 1989 and 1991, interrogated the ENERGY SCIENCE AND TECHNOLOGY database (formerly DOE ENERGY) of the DIALOG⁵ Information Retrieval Service. ENERGY SCIENCE AND TECHNOLOGY, provided by the U.S. DOE, Washington, D.C., is a multi-disciplinary database containing references to the world's scientific and technical literature on energy. All unclassified information processed at the Technical Information Center of the U.S. DOE is included in the database.

In addition, information on many documents has been manually added to *ChernoLit*. Most of this information was obtained in response to requests for data sent to people and/or organizations throughout the world.

CHERNODAT

The Chernobyl Radiological Measurements Information System (*ChernoDat*) is a software package which will provide access to radiological measurements collected in response to PNL requests subsequent to the Chernobyl accident. Data in *ChernoDat* are organized into a central database, containing data in a standardized record format, with multiple satellite databases containing the data in their original record formats. *ChernoDat* will allow the user to browse, query, and export the radiological data from both the central and satellite databases. The browsing feature allows the user to toggle between data in the original record and a standardized record. The query feature allows the user to obtain a data subset and then export the subset to an ASCII file for analysis.

ChernoDat will run on an IBM PS/2, AT, or fully-IBM-compatible computer configured with a VGA monitor, 3-1/2 inch high density floppy disk drive, and a hard drive with 7 megabytes of free disk space. An operating system of DOS 3.3 or higher is required. Performance will increase as the amount of available RAM is increased up to a limit of 16 megabytes.

ChernoDat is implemented as a Paradox⁶ Runtime 3.5 application consisting of pop-up menus, on-line help, and query-by-example filtering. The application requires Paradox Runtime files which will be included with *ChernoDat* on the 3-1/2 inch high density diskettes. An automatic installation program is used to install the compressed format files.

⁵ DIALOG is a registered trademark of Dialog Information Services, Inc., Palo Alto, CA, USA.

⁶ Paradox is a registered trademark of Borland International, Scotts Valley, CA, USA.

At present, the central database consists of over 48,000 records which have been standardized from five satellite databases. The data records in the satellite databases has been donated by the following agencies: State of Washington Department of Social and Health Services (Pickett 1986); Ministry of Agriculture, Fisheries and Food, Welsh Office (1988); Safety Analysis Unit, National Institute of Radiological Sciences - Japan (1988); Chernobyl Protective Measures Assessment Team, United States Nuclear Regulatory Commission (1986); and Stone & Webster Engineering Corporation (1986).

CONCLUSIONS

Two software packages have been prepared by PNL under the Chernobyl Database project for the U.S. DOE. PNL will continue to provide updated products that will assist researchers who are conducting studies related to the Chernobyl accident.

REFERENCES

- Chernobyl Protective Measures Assessment Team, U.S. Nuclear Regulatory Commission. 1986. *Preliminary Assessment of the Chernobyl Accident Radiological Data Provided to the NRC Through May 9, 1986*. NUREG-1219. Washington, D.C., USA.
- Pickett, B. 1986. *DSHS Activities Relating to the Chernobyl Nuclear Accident*. Office of Radiation Protection, Division of Health, Washington State Department of Social and Health Services, Olympia, WA, USA.
- Ministry of Agriculture, Fisheries and Food, Welsh Office. 1988. *Radionuclide Levels in Food, Animals and Agricultural Products 1987, Post Chernobyl Monitoring in England and Wales*. HMS Stationery Office, London, UK.
- Safety Analysis Unit, National Institute of Radiological Sciences. 1988. *Environmental and Health Consequences in Japan due to the Accident at Chernobyl Nuclear Reactor Plant*. NIRS-M-69, Chiba, Japan.
- Stone & Webster Engineering Corporation. 1986. *Compilation of Radiological Measurements from the Chernobyl Accident*. Prepared for Pacific Northwest Laboratories on behalf of the U.S. DOE. Stone and Webster, Boston, MA, USA.

ACKNOWLEDGEMENT

This work is supported by the U.S. DOE under Contract DE-AC06-76RLO-1830.

**LA BASE DE DONNÉES EUROPÉENNES EUROGRID:
PROBLÈMES MÉTHODOLOGIQUES ET DÉVELOPPEMENTS RÉCENTS.**

Sylviane BONNEFOUS et Alain DESPRES
CEA / Institut de Protection et de Sécurité Nucléaire
Département de Protection de la santé de l'Homme et de Dosimétrie

BP n 6 - 92265 Fontenay-aux-Roses CEDEX (France)

**THE EUROPEAN DATA BASE EUROGRID:
METHODOLOGICAL PROBLEMS AND RECENT DEVELOPMENTS**

ABSTRACT

The aim of the EUROGRID data base is to provide the necessary data to estimate the radiological impact and the economic consequences in case of a large nuclear accident. The data taken into account are populations, land use, agricultural productions, livestock and employment for different sectors of the economy. These data are compiled on a 10 000 km² grid basis. To allow such evaluations at short distances of the release source some parameters (populations) are also available on a 100 km² basis. Further parameters are actually considered to estimate the pollution transfer by surface water and the doses received by inhalation or external irradiation.

1. DESCRIPTION SUCCINCTE DE EUROGRID

L'accident nucléaire de Tchernobyl a mis en évidence la prépondérance de l'ingestion dans les doses reçues à grande distance de l'émission. Pour évaluer ou prévoir l'impact individuel et collectif de l'ingestion de produits alimentaires contaminés, il est nécessaire de disposer d'une base de données relative aux populations et aux productions agricoles. C'est dans cette optique que la base EUROGRID a été développée à l'échelle de la Communauté Economique Européenne.

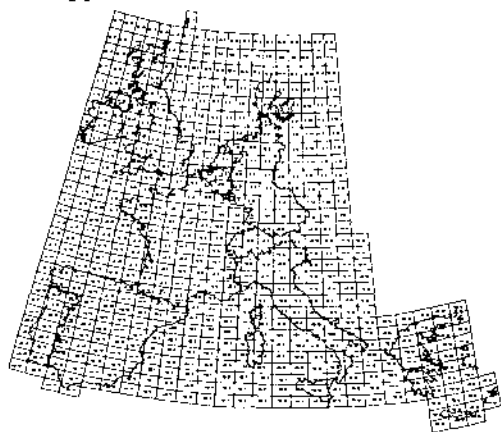

Figure 1: EUROGRID
Grille Européenne

mailles qui couvrent les douze pays de la Communauté Economique Européenne (cf. Figure 1)/1/.

Conjointement à ce projet, le développement de logiciels destinés aux évaluations des conséquences économiques d'un accident de type radiologique (ou chimique) a conduit à enrichir EUROGRID de paramètres participant à l'estimation des coûts (effectifs salariés par exemple).

Les paramètres inclus dans la base de données sont: les populations résidentes, l'utilisation des sols, les productions agricoles, le nombre d'emplois par secteur d'activité économique et la quantité de lait collectée. Ils sont évalués pour chacune des mailles de 10 000 km²,

L'évaluation des conséquences d'un accident à partir d'un réseau maillé suppose que la concentration des polluants (dans l'air ou au sol) est homogène à l'intérieur d'une maille. Dans le cas de mailles de 10 000 km², cette hypothèse n'est acceptable qu'à grande distance de l'émission. Pour évaluer les conséquences à courte distance, un maillage de 100 km² a été défini et une base de données sur ce maillage est en cours de documentation.

2. LES DIFFICULTÉS MÉTHODOLOGIQUES

Les problèmes méthodologiques sont de deux ordres :

1 - L'acquisition des données

En ce qui concerne **les populations**, la précision des données existantes dans tous les pays au moyen des recensements autorise une confiance suffisante, même dans la grille à mailles fines. Les données sont en effet disponibles au niveau des communes dont on connaît les coordonnées géographiques. Cependant, il faut être conscient que ces recensements ne fournissent qu'une valeur approximative de la population présente dans une maille à un moment donné (périodes estivales, zones industrielles, ..).

L'acquisition des données concernant **les surfaces et les productions agricoles** est plus délicate: l'idée initiale, qui consistait à exploiter des images provenant de satellites, a été rapidement abandonnée, essentiellement à cause de son coût prohibitif. L'utilisation des statistiques locales se heurte à une difficulté majeure: plus le niveau d'acquisition des données est fin, plus on se heurte au secret statistique. Une solution de compromis a été retenue; elle consiste à utiliser les données au niveau régional telles que collectées et publiées par EUROSTAT /2/, et à ventiler les données dans les mailles en fonction de la portion de surface des régions dans chaque maille. L'homogénéité de ces données n'est qu'apparente, car il existe de grandes disparités entre les équipements et l'organisation des services statistiques des pays de la Communauté; ces différences apparaissent clairement dans les publications EUROSTAT au niveau du recueil varie de la région au pays tout entier.

En ce qui concerne **l'emploi**, le degré d'élaboration des données est très différent d'un pays à l'autre; la nécessité de disposer d'une classification commune à tous les pays nous a conduit ici encore à utiliser les données EUROSTAT.

Enfin, les seules données disponibles au niveau des **produits laitiers** concernent la collecte du lait, connue au niveau des laiteries. Chaque laiterie peut couvrir des zones de collecte importantes et dispersées géographiquement.

Une difficulté essentielle dans la réalisation de la base de données est la nécessité d'une actualisation régulière et la prise en compte des bouleversements géopolitiques récents (réunification de l'Allemagne).

2 - La réalisation de logiciels d'exploitation

L'utilisation de cette base de données a nécessité le développement de produits logiciels permettant l'interrogation de la base et la visualisation des données. Deux produits, accessibles sur micro-ordinateur, ont été récemment réalisés. Le premier (QUERY), exploite la base de données sur grandes mailles (10 000 km²); il permet de formuler une requête c'est à dire de délimiter une zone de la Communauté répondant à certains critères (cf. Figure 2); de visualiser la zone correspondant au critère de sélection, puis d'interroger les mailles de la zone sur la valeur de paramètres sélectionnés par l'utilisateur (cf. Figure 3). Le second logiciel, entièrement graphique (EUROVISU) permet en outre la consultation des données sur le système de mailles fines (100 km²).

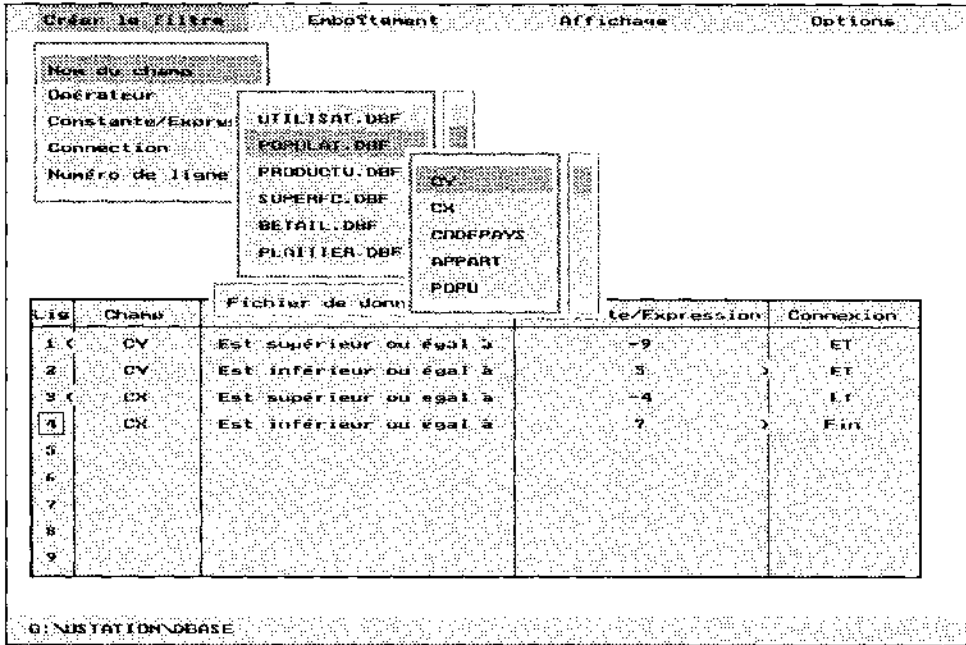

Figure 2 : Construction d'une requête

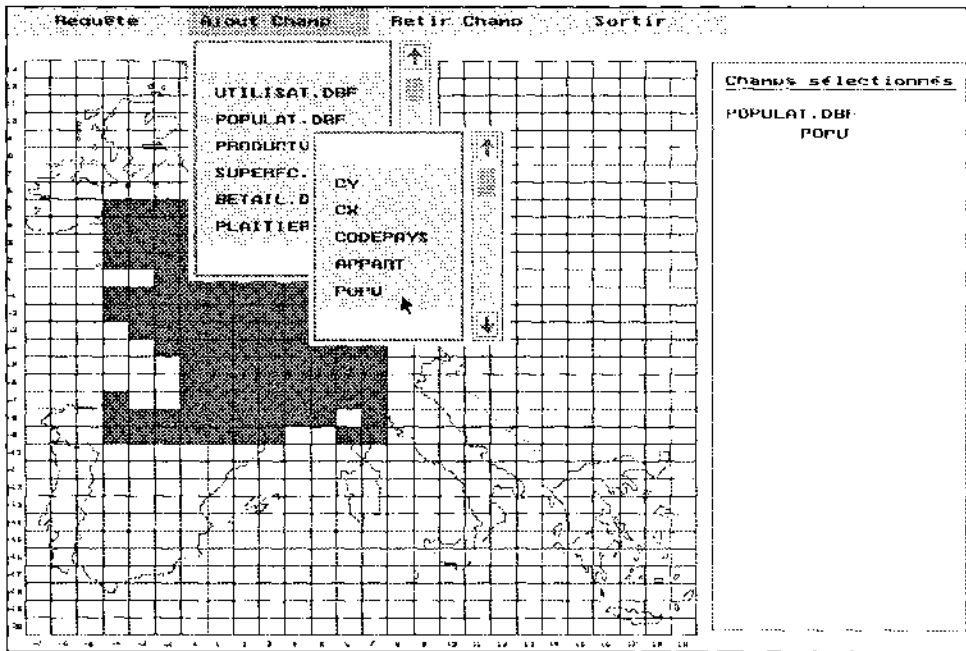

Figure 3 : Visualisation et interrogation de la base

3. LES DÉVELOPPEMENTS DE EUROGRID

En plus de l'**extension géographique** (l'introduction de l'Allemagne unifiée est prévue, celle des pays de l'Est est envisagée), on cherche actuellement à enrichir la base de données par des informations permettant une évaluation des **transferts par l'eau** (emplacement des stations de pompage, quantités prélevées, zones de distribution et d'utilisation (irrigation, usage industriel ou domestique)). Une étude de faisabilité est en cours. De plus, l'introduction des données relatives aux **caractéristiques de l'habitat et du mode de vie** permettra l'estimation des expositions par inhalation et par irradiation externe. Enfin, pour tenir compte du fait que zones de production et de consommation ne sont pas identiques, on souhaite introduire des **coefficients d'échanges entre mailles**, sur la base de statistiques douanières ou de flux interrégionaux.

RÉFÉRENCES

1. A. GARNIER
Progress in the Preparation of Demographic and Land Use Data Base
Joint CEC/OECD (NEA) Workshop on Recent Advances in Reactor
Accident Consequence Assessment, Rome (Italy), 25-29 Janvier
1988.
2. EUROSTAT
Régions, Annuaire Statistique, Thème 1, Série A, 1987.

REMERCIEMENTS

Les travaux présentés ont bénéficié d'un financement des Communautés Européennes : contrat d'Association Euratom-CEA DGXII B16-122 F (D).

MONITORING MAN-MADE RADIATION USING A 256 CHANNEL
PORTABLE GAMMA-RAY SPECTROMETER

R.L. GRASTY¹, J. MULTALA², AND H. LEMMELA³

¹Geological Survey of Canada, Ottawa, Ontario, K1A-0E8, Canada.

²Geological Survey of Finland, SF-02150 Espoo, Finland.

³Finnish Centre for Radiation and Nuclear Safety, Helsinki, Finland.

ABSTRACT

Measurements in Finland with a portable NaI(Tl) gamma-ray spectrometer showed that the natural gamma-ray spectra from potassium, uranium and thorium could be separated from the gamma-ray spectra of ¹³⁴Cs and ¹³⁷Cs due to fallout from Chernobyl. A comparison of the portable spectrometer measurements with those from an ionization chamber showed that the dose rate due to ¹³⁴Cs and ¹³⁷Cs fallout and the individual dose rates from the three natural components could be determined with a portable spectrometer. Following calibration at one site of known contamination, the portable spectrometer could also be used to measure the deposition of ¹³⁴Cs and ¹³⁷Cs.

INTRODUCTION

Portable Na(Tl) gamma-ray spectrometers have been used by geologists and geophysicists for mineral exploration and geological mapping for many years. These spectrometers normally use a 7.6 x 7.6 cm detector and record 3 energy regions for monitoring gamma-ray emissions from potassium, uranium and thorium. Recently, portable spectrometers which record up to 256 channels of gamma-ray spectral data have become available. This paper describes how such a spectrometer (an Exploranium GR-256) can be used for environmental monitoring.

PRINCIPLE OF THE METHOD

Following a nuclear reactor accident, such as the Chernobyl event of 1986, many man-made radio-nuclides with a variety of gamma-ray energies and half-lives may contaminate the environment. Almost all these gamma-ray emitters have energies which are significantly below the 1460 keV gamma-ray peak of ⁴⁰K. By fitting the calculated potassium, uranium and thorium gamma-ray spectra to the high energy part of measured spectrum, the natural gamma-ray component can be determined. This component can then be removed from the measured spectrum, leaving behind the man-made component.

The procedure was first tested in Canada where the man-made component originated mainly from global atomic weapons fallout. Figure 1 shows a spectrum recorded outside the Geological Survey of Canada headquarters in Ottawa with a 256-channel portable spectrometer using a 7.6 cm x 7.6 cm NaI(Tl) detector. The natural gamma-ray component of the measured spectrum (also shown in the figure) was computed by fitting the calculated potassium, uranium and thorium spectra to the observed spectrum above an

energy of 1200 keV. The three natural gamma-ray spectra were determined from measurements on concrete calibration blocks, 1m x 1m x 30cm with known concentrations of the three radioactive elements. The fitted spectrum also includes the background contribution from cosmic radiation, radon decay products in the air and any radioactivity from the instrument itself. The background was measured in a small metal boat on the nearby Ottawa river.

The fallout spectrum shown as the difference spectrum in Figure 2 originates from an estimated 2.5 kBq/m² of ¹³⁷Cs and demonstrates the effectiveness of the spectral fitting method even in areas of low fallout.

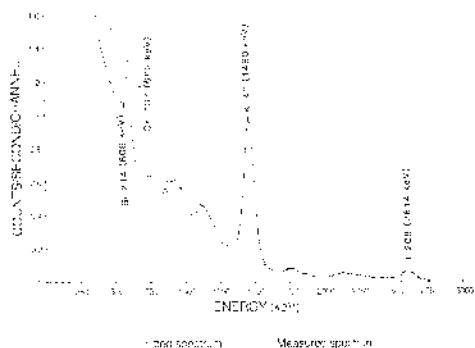

Figure 1. A computer fit above 1200 keV of the potassium, uranium and thorium spectra to a spectrum measured in Canada.

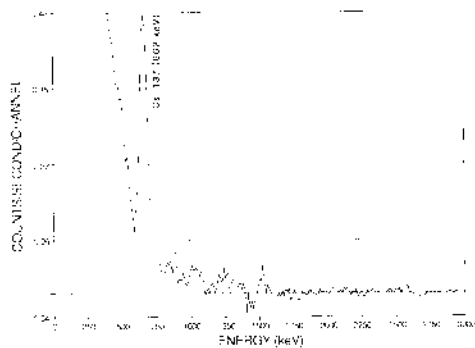

Figure 2. The fallout spectrum obtained by subtracting the natural gamma-ray spectrum from the measured spectrum.

FIELD MEASUREMENTS

In the fall of 1990, a series of gamma-ray measurements were made in the Lammi - Padasjoki - Jämsä area in Finland where the ¹³⁷Cs contamination was as high as 200 kBq/m². Simultaneous measurements were performed with a calibrated Reuter-Stokes ionization chamber and the calibrated portable spectrometer at a measurement height of 80 cm above the ground. Additional measurements were made with the portable spectrometer at ground level to estimate variations in the radioactivity of the ground. At selected locations, soil samples were taken for laboratory determinations of ¹³⁴Cs and ¹³⁷Cs.

ANALYSIS OF RESULTS

Measurement of fallout

Figure 3 shows a measured spectrum and the fitted natural spectrum from a site where the ¹³⁷Cs deposition was approximately 120 kBq/m². The background spectrum, included in the fitted natural spectrum, was measured in a small boat on the Gulf of

Finland. The man-made difference spectrum (Figure 4) shows the 662 keV gamma-ray peak of ^{137}Cs as well as the gamma-ray peak at 795 keV due to ^{134}Cs which has a half-life of approximately 2 years. The gamma-ray windows used to measure ^{134}Cs and ^{137}Cs are shown in the difference spectrum. A correlation of the ^{137}Cs window count rates from the man-made spectrum with those from ^{134}Cs (Figure 5) shows that the $^{134}\text{Cs}/^{137}\text{Cs}$ ratio is the same for all sites measured. A similar correlation coefficient of 0.998 was also found from the laboratory analyses of the soil samples.

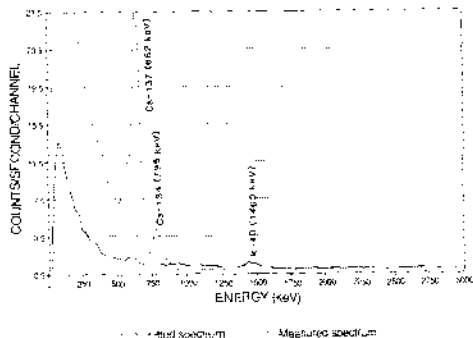

Figure 3. A computer fit above 1200 keV of the potassium, uranium and thorium spectra to a spectrum measured in Finland.

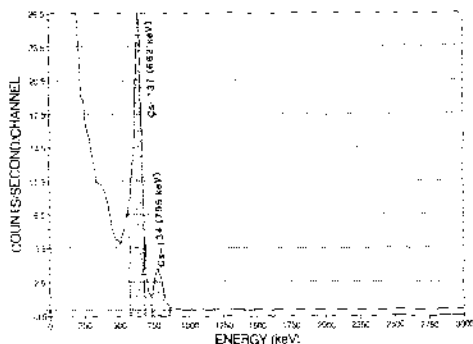

Figure 4. The fallout spectrum obtained by subtracting the natural gamma-ray spectrum from the measured spectrum.

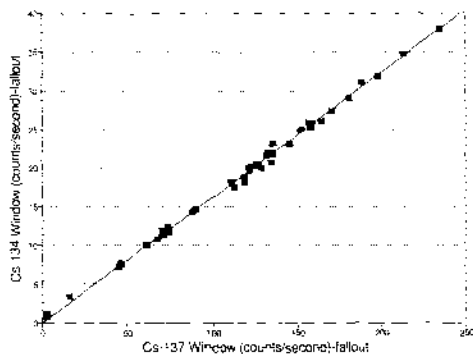

Figure 5. Correlation of the ^{134}Cs and ^{137}Cs window count rates from fallout.

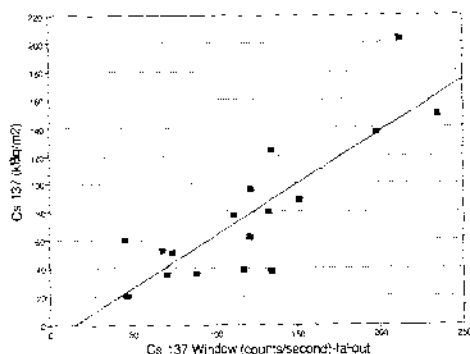

Figure 6. Correlation of the ^{137}Cs window from fallout with ^{137}Cs deposition.

The laboratory measurements of ^{137}Cs deposition were compared with the calculated count rates in the ^{137}Cs window from fallout (Figure 6). The scatter about the least squares line was attributed to localized variations in the deposition of ^{137}Cs

which were found by analyzing the ground-level gamma-ray measurements. The results show that following calibration at one site where the contamination is uniform, a NaI(Tl) gamma-ray spectrometer can be used to measure ^{134}Cs and ^{137}Cs .

Measurements of dose rate from fallout

In the spectral fitting procedure, the gamma-ray spectral shapes from unit concentrations of potassium, uranium and thorium are used to calculate the concentrations of the three radioactive elements in the ground. The individual air absorbed dose rates can then be calculated from these concentrations using the relationship:

1 percent potassium = $0.0131 \mu\text{Gh}^{-1}$
 1 part per million of uranium in equilibrium = $0.00543 \mu\text{Gh}^{-1}$
 1 part per million of thorium in equilibrium = $0.00269 \mu\text{Gh}^{-1}$

The ionization chamber measurements include radiation from fallout and natural gamma radiation as well as a background component from cosmic radiation and radon decay products in the air. This background was also measured on the Gulf of Finland. The radiation dose from fallout can therefore be determined from the ionization measurements by subtraction of the background plus the calculated natural radiation dose.

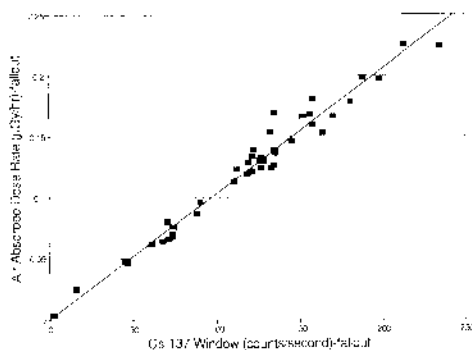

Figure 7. Correlation of the ^{137}Cs window count rate from fallout with the dose rate due to fallout.

The fallout component of the radiation dose, deduced from the ionization chamber measurements is compared with the portable spectrometer ^{137}Cs window count rates from fallout in Figure 7. The good correlation ($R = 0.95$) shows that a NaI(Tl) spectrometer can be used to measure the radiation dose from fallout, following calibration at one site with an ionization chamber. At the same time, the calculated ground concentrations of potassium, uranium and thorium can be used to estimate the radiation dose from each natural radioactive element.

RADIATION EXPOSURE DUE TO INCORPORATION OF RADIONUCLIDES
IN TWO SELECTED PLACES OF THE RSFSR FIVE YEARS AFTER THE
CHERNOBYL ACCIDENT

P. Hill, R. Hille
Forschungszentrum Jülich GmbH
W-5170 Jülich, FRG

ABSTRACT

First results of a large scale survey on the body content of radionuclides of Russian people during summer 1991 are presented. Data obtained for two villages of Klincy county (district of Briansk) are compared to those obtained in Klincy. An average body burden of 2 kBq, 3.7 kBq and 22 kBq Cs-137/134 has been found in Klincy town, Pestschanka and Weprin respectively corresponding to whole body doses of 0.08 mSv/a, 0.14 mSv/a and 0.88 mSv/a in 1991 resulting from incorporation of Cs-activities mainly through ingestion. The interdependence of environmental and body burden is discussed.

INTRODUCTION

During summer 1991 the environmental burden (water, soil, nutrition) and the body content of γ -emitting radionuclides of more than 150.000 persons in the RSFSR have been examined by a German expedition in close collaboration with the RSFSR's Goskom Chernobyl. The project was financed by the Federal Minister of Environment and carried out by the Research Centre Jülich (KFA). An area of approximately 10 000 km² extending from close-to-Moscow Tula up to Slynka at the Byelorussian border and such including regions of low and high contamination levels in the districts of Briansk, Kaluga, Orel and Tula has been covered in the survey. Up to 7 mobile environmental and whole-body counting laboratories have been operational with a total number of 7 γ - spectrometers and 20 whole-body- counters. About 150 german specialists have participated in the task group.

Each person examined received an official certificate giving the activity of the Cs 137/134 mixture in the body and a judgement on the radiation risk involved. Observed activity levels were generally much less and in no case higher than the annual limit of intake acceptable for professional radiation

workers. Only for less than 1 % of the people examined the results suggest the necessity of a further surveillance by health physicists and physicians similar to the regular medical examination professional radiation workers undergo.

The results obtained in two villages of Klincy county bearing a higher than average environmental burden and /or activity content of nutrition are presented and compared to those obtained in Klincy town.

KLINCY COUNTY

Klincy county is situated in the western part of Russia close to the Byelorussian border approximately 100 km east of Gomel and 160 km west of Brjansk. The town of Klincy (80.000 inhabitants) being the second largest city of Brjansk district is as well an administrative as an industrial center of this else rural region. The countryside is hilly and there are little woods. Each of the twenty sowchoses provides a place of living for an average 1200 inhabitants and consists of 2 - 3 villages. Weprin showing the highest dose rates of environmental radiation in the county is located in its western part. Pestschanka is situated in a less contaminated area north of Klincy.

EXPERIMENTAL PROCEDURE

Two small lorries each equipped with two QMB-1 incorporation monitors have been used to examine the village's population. Each monitor contained in a chair configuration two plastic-scintillation detectors calibrated for a Cs 137/134 mixture corresponding to the well known mixture of post-Chernobyl Cs-activities. The detectors have been shielded by 1 cm of lead. The data evaluation procedure included a correction of contributions from natural K-40 radiation. It could be shown that those are the only γ -emitting radionuclides of some importance. Additional corrections include self-absorption of β -rays in the body and shielding of background radiation by the examined persons. The mean detectable activity has been estimated to be 1 kBq.

Two Herfurth incorporation monitors have been used to examine a control group in Clincy town. Each of them contained one large plasticscintillator detector in a bed configuration calibrated to the Cs 137/134 mixture observed. The lead

shielding was 5 cm thick. Absorption of sky-shine and cosmic radiation by the body had been estimated with water phantoms and was accounted for in the data evaluation procedure. The mean detectable activity is less than 0.5 kBq.

In all cases the activity has been assumed to be distributed in the whole body. Depositions in the lung or in the G.I.-tract would be over estimated.

RESULTS AND DISCUSSION

A total of 172 people were measured in the village of Pestschanka and 199 out of Weprin's 300's population could be examined. The percentage of young people has been 17.6 % in Weprin and 37.2 % in Pestschanka. For the control group an arbitrary fortnights examinations have been selected out of the measurements done with Herfurth incorporation monitors in Klincy town. The group consisted of 4170 persons including 375 young people.

Activities determined in Klincy ranged from 0 to 49 kBq the average value being 2 kBq. In Pestschanka generally slightly higher activities have been found. An average activity of 3.7 kBq has been calculated. In the village of Weprin the activity distribution is considerably shifted to higher values the average activity being 22 kBq. The maximum activity observed has been 115 kBq.

Average specific activities have been calculated to be 28 Bq/kg in Klincy, 67 Bq/kg in Pestschanka and 330 Bq/kg in Weprin. It should be noted that in Jülich (FRG) this value has been 0.3 Bq/kg in 1990.

Assuming continual intake and using dosefactors of ref. 1 valid for adults to determine the dosefactor of the Cs 137/134 mixture average doses of 0.08 mSv/a for Klincy, 0.14 mSv/a for Pestschanka and 0.88 mSv/a for Weprin can be evaluated.

Using a method proposed by Sauermann (ref.2) to estimate the lifetime doses by comparison with a Berchtesgaden(FRG) control group average values of 3.6 mSv, 6.7 mSv and 40 mSv result in the case of men for Klincy, Pestschanka and Weprin respectively.

Average body burdens found are given in Table 1 together with results of an investigation on the environmental burden (ref. 3). Table 1 shows a strong correlation of body burdens and activity content of nutrition. It suggests body burdens to be due to ingestion. It is known that in rural areas the nutrition of people is mainly self-produced. Therefore the strong correlation between environmental and body burden is typical for small villages. In urban areas the global nutrition support is more important. Therefore the average incorporation is in Klincy town by a factor of nearly 2 lower than that of Pestschanka although the soil activity is much higher. Furthermore this indicates that the body burden does not result mainly from inhalation of dust even not if the summer was hot and dry like that of the year 1991.

	average body burden		dose	soil	milk + dairy	berries +
	total	specific	rate		products	mushrooms
	kBq	Bq/kg	$\mu\text{Sv/h}$	kBq/ m^2	Bq/l resp. Bq/kg	Bq/kg
Klincy	2.0	28	0.26	190	< 64	< 230
Pestschanka	3.7	67	0.17	71	120	250
Weprin	22	330	0.92	1000	810	2600

Table 1: Average values of incorporated and environmental (ref.3) Cs 137/134 activities. All numbers are rounded to two significant digits.

REFERENCES

1. A.S.Keverling Buisman, From Body Burden to Effective Dose Equivalent- a Compilation of Data for the Evaluation of Whole Body Counter Measurements, ECN-116, April 1982
2. P.Sauermann, private communication
3. K.Heinemann, Meßprogramm der Bundesrepublik Deutschland- Ergebnisse der Umweltmessungen in Rußland in der Zeit vom 21. Mai bis 11. Juni 1991, Jül-2531, Oktober 1991, ISSN 0366-0885

ACKNOWLEDGEMENTS

We are grateful to K. Helling, Dr. S. Hübener, A. Köster, M. Lochter, Dr. B. Naumann, Dr. L. Naumann, H. F. Oetjen, H. Pütz, Dr. P. Sahre, H. Seifert, M. Schlett, W. Schulze and Dr. A. Zeuner for help in data taking, M. Hintzen for help in data analysis and H. Köp for typing. The close and excellent collaboration of the RSFSR's committee of liquidation of Chernobyl consequences is thankfully acknowledged. Thanks are also due to the German Ministry of environmental affairs (BMU) for funding.

CALIBRATION OF PERSONAL DOSEMETERS IN TERMS
OF THE ICRU OPERATIONAL QUANTITIES

Joseph C. McDonald
Pacific Northwest Laboratory
Richland, Washington 99352, USA
and
Nolan E. Hertel
Mechanical Engineering Department
The University of Texas at Austin
Austin, Texas 78712, USA

ABSTRACT

The International Commission on Radiological Units and Measurements (ICRU) has defined several new operational quantities for radiation protection purposes. The quantities to be used for personal monitoring are defined at depths in the human body. Because these quantities are impossible to measure directly, the ICRU has recommended that personal dosimeters should be calibrated under simplified conditions on an appropriate phantom, such as the ICRU sphere. The U.S. personal dosimetry accreditation programs make use of a 30 x 30 x 15 cm polymethylmethacrylate (PMMA) phantom, therefore it is necessary to relate the response of dosimeters calibrated on this phantom to the ICRU operational quantities. Calculations of the conversion factors to compute dosimeter response in terms of the operational quantities have been performed using the code MCNP. These calculations have also been compared to experimental measurements using thermoluminescent (TLD) detectors.

INTRODUCTION

The ICRU has defined four operational quantities that are recommended for radiation protection (ICRU, 1985). The ambient and directional dose equivalents are to be used for the environmental, or area, monitoring of strongly and weakly penetrating radiations, respectively. These quantities are specified at depths in the ICRU sphere (ICRU, 1980). The quantities for personal monitoring are the individual dose equivalents, penetrating and superficial. These quantities are also defined for strongly and weakly penetrating radiation, respectively. The individual dose equivalent quantities are specified at depths in the human body, so it is impossible to measure them directly. In practice, a personal dosimeter is constructed so that the detecting element is covered by an appropriate amount of tissue-equivalent material, and this dosimeter is then calibrated on a simplified tissue-equivalent phantom. However, most dosimeters in use in the U.S. are sensitive to backscattered radiation from the body and from calibration phantoms. When calibrations are performed with dosimeters mounted on a PMMA slab phantom, corrections must be applied to account for differences in backscatter between the PMMA phantom and the ICRU sphere.

In the U.S., there are two programs for the accreditation of personal dosimeters. They are the Department of Energy Laboratory Accreditation Program (DOELAP) and the National Voluntary

Laboratory Accreditation Program (NVLAP). These programs require the use of a rectangular PMMA phantom (DOE, 1986, ANSI, 1983). Therefore, conversion factors are needed to relate the response of dosimeters irradiated on a PMMA phantom to the operational quantities. Calculations of this type have been performed for photon and neutron irradiations (Hertel and McDonald, 1990, 1991).

CALCULATIONS AND MEASUREMENTS

The determination of values for conversion factors can be accomplished either by calculation or measurement, or both. The most desirable situation is to use both methods and compare the two. It has been the approach at the Pacific Northwest Laboratory to use the Monte Carlo computer code MCNP (ORNL, 1983) and to perform confirmatory measurements in a geometry that closely approximates the conditions used in the irradiations for the accreditation programs.

The first case considered in the calculations was for photon irradiations. The dose equivalent at a depth of 1 g/cm^2 in the ICRU sphere was calculated along with the dose equivalent at a depth of 1 g/cm^2 in a PMMA dosimeter placed on the face of a $30 \times 30 \times 15 \text{ cm}$ PMMA phantom. This approximates the recommendation given by the ICRU for a dosimeter to be covered with an appropriate amount of tissue equivalent material and calibrated on a suitable phantom (ICRU, 1988). The front face of the phantom was placed at a distance of 100 cm from point sources of radiation that were used to simulate the actual irradiation conditions. Similar calculations were performed with the ICRU sphere as a phantom.

Backscatter factors were measured with thermoluminescent dosimeters ^7LiF (TLD-700) chips placed either on the surface of a PMMA slab phantom or on a thin water filled plastic sphere that was 30-cm in diameter. Corresponding measurements at the same reference distance were made with the TLD mounted free-in-air (Large, et al., 1990). Results of the measurements and calculations are shown in Table 1. For dosimeters sensitive to backscatter, these results could be used to correct the air kerma to directional dose equivalent, $H'(10)$, conversion factors. These data also compare favorably to the recent calculations of Bartlett, et al. (1991).

The calculations for neutron irradiations used the larger $40 \times 40 \times 15 \text{ cm}$ PMMA phantom required by the accreditation programs (DOE, 1986, ANSI, 1983). The front face of this phantom was placed at 50 cm from the radiation sources. A PMMA dosimeter was again mounted on both the surface of this phantom and on the ICRU sphere. The dose equivalents at a depth of 1 g/cm^2 in the ICRU sphere and at the same depth in the dosimeter were calculated. The results of these calculations are shown in Table 2. The present results are within the expected uncertainties of previously reported calculations of conversion factors between fluence and $H'(10)$. Confirmatory measurements are planned for the neutron irradiations using TLD-albedo dosimeters and CR-39 plastic track-etch dosimeters.

CONCLUSIONS

The process of relating the response of dosimeters, calibrated in terms of metrological quantities, to the operational or limiting quantities can be accomplished by the use of appropriate conversion factors. It is also possible to calibrate dosimeters on the rectangular solid PMMA phantoms required by the U.S. accreditation programs, and to relate the response of such dosimeters to the ICRU operational quantities. The conversion factors given in this report were calculated by the Monte Carlo code MCNP and compared to measurements taken with TLD's. The agreement obtained between these two methods was within the expected uncertainties for them. Future work will include the verification of the neutron conversion factors by experimental measurement.

ACKNOWLEDGMENTS

The authors would like to thank K.K. Large and R.J. Traub for their help with the calculations and measurements. This work was supported by the U.S. Department of Energy under Contract DE-AC06-76RLO-1830.

Table 1. Calculated and Measured Ratios of Photon Backscatter Factors for the 30 x 30 x 15-cm PMMA phantom relative to the ICRU sphere.

<u>Photon Energy (keV)</u>	<u>Calculated BSF Ratio</u>	<u>Measured BSF Ratio</u>
10	1.0	-
20	1.05	0.98
30	1.13	1.19
40	1.23	1.22
50	1.29	-
60	1.26	1.27
80	1.26	1.19
100	1.17	1.06
200	1.09	-
300	1.05	-
662	1.03	1.06
1250	1.02	1.03

Table 2. Calculated Fluence to Directional Dose Equivalent Conversion Factors for Dosimeters Irradiated on the 40 x 40 x 15-cm PMMA phantom and the ICRU sphere. Values are given in terms of pSv/cm² (Hertel and McDonald, 1991).

<u>Neutron Energy (MeV)</u>	<u>PMMA Phantom</u>	<u>ICRU Sphere</u>
0.001	6.1	6.2
0.1	66.6	67.1
1.0	361	375
D ₂ O Moderated ²⁵² Cf	87.8	93.2
Unmoderated ²⁵² Cf	332	343

REFERENCES

- ANSI (1983). American National Standards Institute, "American National Standard for Dosimetry-Personnel Dosimetry Performance-Criteria for Testing", ANSI N13.11-1983 (American National Standards Institute, Washington, D.C.).
- Bartlett, D.T., Dimbylow, P.J. and Francis, T.M., "Calculated Backscatter from Phantoms for Photon Dosemeter Calibration", *Radiat. Prot. Dosim.* 32(2), 123-125 (1990).
- DOE (1986). U.S. Department of Energy, "Department of Energy Standard for the Performance Testing of Personnel Dosimetry Systems", DOE EH-0027 (U.S. Department of Energy, Washington, D.C.).
- Hertel, N.E. and McDonald, J.C., "Methods for the Calibration of Photon Personnel Dosimeters in terms of the Ambient Dose Equivalent", *Radiat. Prot. Dosim.* 32 (3), 149-156 (1990).
- Hertel, N.E. and McDonald, J.C., "Calibration of Neutron Personnel Dosimeters in terms of the ICRU Operational Quantities", *Radiat. Prot. Dosim.* 37 (3), 149-156 (1991).
- ICRU (1980). International Commission on Radiological Units and Measurements, "Radiation Quantities and Units", ICRU Report 33 (International Commission on Radiological Units and Measurements, Bethesda, Maryland).
- ICRU (1985). International Commission on Radiological Units and Measurements, "Determination of Dose Equivalents Resulting from External Radiation Sources", ICRU Report 39 (International Commission on Radiological Units and Measurements, Bethesda, Maryland).
- ICRU (1988). International Commission on Radiological Units and Measurements, "Determination of Dose Equivalents from External Radiation Sources-Part 2", ICRU Report 43 (International Commission on Radiological Units and Measurements, Bethesda, Maryland).
- ORNL (1983). Oak Ridge National Laboratory, Radiation Shielding Information Center, Computer Code Collection, CCC-200, Los Alamos Radiation Transport Group X-6. "MCNP Monte Carlo Neutron and Photon Transport Code" (Oak Ridge National Laboratory, Oak Ridge, Tennessee).

Evaluation of Methods of Calculating the Internal Dose
from Radionuclides Deposited in the Human Body

Karl Z. Morgan
113 Danbury Drive
Oak Ridge, TN 37830

Since the Chalk River Tripartite Conference in Chalk River, Canada in September 1949, there has been very little change in the method of calculation of dose to the critical body organ. In this paper some of the early developments in health physics are reviewed and a new perspective is provided by obtaining the dose, d , in tissue spheres of radius equal to the range of alpha particles. A dust particle with the average alpha contamination is at the center of each sphere. Then some of the spheres are compacted (crushed) to fill up a form (mold) equal in shape to that of the critical body organ. The ratio of the number of spheres comprising the total radioactivity to the number of spheres fitting into the form is the overlap, p , and the total dose to the critical body organ is equal to $d \times p$.

Health physics originated about the time the first pile (reactor) began operating at the University of Chicago on December 2, 1942. The first health physicists (E.O. Wollan, H.M. Parker, C.C. Gamertsfelder, J.C. Hart and K.Z. Morgan) transferred from Chicago to Clinton Laboratories, now Oak Ridge National Laboratories, ORNL, in September 1943. Wollan left health physics at this time and in the fall of 1944 Parker, Gamertsfelder and Hart moved to Richland, Wash. where they established the health physics program at the Hanford plutonium producing facility. This left me as director of the ORNL Health Physics Division.

One of the major health physics problems in the early period was that of setting the maximum permissible body burden, Q , and maximum permissible concentration, MPC, of radionuclides in air, water and food. H.M. Parker at Hanford, J.H. Hamilton at Berkeley, W.H. Langham at Los Alamos, J.E. Rose and L.D. Marinelli at Argonne National Laboratory, G. Failla at Columbia University, A.J. Cipriani at Chalk River, J.S. Mitchell and G.J. Neary in London and I at ORNL each came up with different values of Q and MPC. The differences were due to different methods of calculation and the use of different input parameters.

One of the problems in setting radiation protection standards during the war was the tight security which limited exchange of information and sometimes was enforced at a ridiculous level. For example, our Health Physics Division was forced to change the name of the instrument we developed and called Pluto because it suggested Plutonium. We had named it Pluto after the cartoonist's snooping dog named Pluto so we changed the name to Snoopy. In 1945 I prepared a paper for publication suggesting how to make calculations on internal dose, setting for example $\lambda = \lambda_r + \lambda_b$ where λ_r and λ_b are the radioactive and biological elimination coefficients, respectively, and using the relation $dQ/dt = P - \lambda Q$ and giving mathematical procedures for dealing with parent-daughter radionuclide relationships and values of Q and MPC for 13 radionuclides. But, alas, the paper was held up for years and not released by security until finally it was published in 1947.¹ So far as I am able to determine this was the first paper published showing how these calculations should be made.

During this early period it occurred to me that if I knew the stable element distribution in the body organs and their concentration in food, water, urine and feces, I could determine quite easily how radioisotopes of these same elements are taken up, retained and eliminated. I went to the library expecting to copy down these values for common elements such as Sr, Cs, Co, Fe, Zn, P, K, I, U, Th, etc in one afternoon but after searching for a week, I was convinced such data had not been published. Then I arranged a contract with Isabel Tipton of the University of Tennessee to work with us in conducting an X-ray and neutron activation analysis of elements in tissue of human body organs. Mary J. Cook from our Health Physics Division visited pathology laboratories all over the US collecting samples of human body organs for these analyses and many samples were sent to us from overseas. This study resulted in the publication of concentration values for 33 elements in 37 human body organs as published in ICRP-2 (1959).² These data were extremely valuable in obtaining Q and MPC values.

One of the problems in the calculation of Q and MPC in this early period was that each person making these calculations used his own values of organ mass, element composition of body organs, rate of intake of air, water and food, the urine and fecal elimination rates, body water, etc. Mary Jane Cook of our Division and H. Lisco of Argonne National Laboratory independently collected these data and I presented them at the Chalk River Conference (1949). This led to the establishment of the Standard Man, many of whose features were published in the ICRP-2 report in 1959. After the Chalk River Conference most internal dose calculations referred to the Standard Man so it became much easier to compare calculations of Q and MPC. Years later under the chairmanship of W.S. Snyder, ICRP-23³ was published giving much more detailed information (480 pages) regarding Standard Man and his name was changed to Reference Man.

There were 25 attendees at the Chalk River Conference, 5 from the UK, 9 from Canada and 11 from the US. This conference served as a mile post and principal beginning of international cooperation and standardization in the fields of both internal dose and of external exposure. Here we did much more than christen Standard Man and set values of MPC for 18 radionuclides. This was a new beginning for health physics at the international level. Prior to this time I had had frequent meetings with H.M. Parker, W.H. Langham, L.L. Marinelli etc. from the US and occasional meetings with world leaders including I.H. Gray, W.V. Mayneord, R.M. Sievert, etc. This meeting at Chalk River was the spark that led to the reorganization of the International X-ray and Radium Protection Committee which, organized in 1928, had ceased to function during the war years after 1937. The 1950 meeting of ICRP in Harwell, England marked what some consider the beginning of ICRP. Here we set the stage for the formation of the Health Physics Society at Columbus, Ohio in 1955.

In 1953 NCRP-52⁴ was published giving Q and MPC values for 45 radionuclides and in 1955 ICRP published values of Q and MPC for 93 radionuclides in the British Journal of Radiology.⁵ ICRP-2 and NCRP-69⁶ were both published in 1959 and the texts of the two were almost identical--perhaps not surprising because I was chairman of the Internal Dose Committees of both NCRP and ICRP during the 20 year period following 1950. ICRP-2 and NCRP-69 each gave Q and MPC values for 236 radionuclides. W.S. Snyder and Mary Rose Ford did most of the tedious calculations in grinding out these values.

Before I retired from active membership in ICRP in 1971, our internal dose committee was criticized for using the same occupational dose limit of 5 rem/y for total body, gonads and active (red) bone marrow. Obviously, whole body dose should be lower than dose to individual organs. Snyder and I argued that the solution was simple--just lower the whole body limit to 2.5 rem/y. Unfortunately, ICRP in ICRP-26⁷ (1977) removed this discrepancy in the wrong direction and it was not until 1990⁸ that ICRP reduced the level to 2 rem/y. The dose limit was kept at 5 rem/y for total body but raised for all other body organs in subsequent publications of ICRP-30⁹ (1979-88). MPC values should have been reduced, not raised. ICRP's use of the target organ that receives dose from radionuclides in organs outside the critical organ as well as that from radionuclides within the critical organ was a welcome improvement in ICRP-30 that could be implemented only in later years when computers could lend a hand. I am pleased with the lower values of MPC in ICRP-61 published in 1991 but most of the values are still too high.

Over the past 15 years I have assisted some 150 persons injured by exposure to ionizing radiation in their efforts to obtain compensation for their injury. In 1989 I was involved with E.P. Radford in the Martin case in which a family sold their home at a loss because it was contaminated with plutonium resulting from substandard waste disposal practices at the Windscale, England nuclear facility. In the course of calculation of the dose to the critical epithelial lung tissue by the usual gross dose method, it occurred to me why be stuck with this same old gross dose method I developed 45 years ago. By the familiar gross dose method I had calculated the annual dose to 1 g of the epithelial tissue as

$$\text{Total Dose} = \frac{5.05 \times 10^{-3} Q(\text{Bq}) E(\text{MeV/dis}) RBE(\text{Sv/Gr})}{5.05 \times 10^{-3} \times 0.0275 \times 5.3 \times 20} = 0.0147 \text{ Sv/y}$$

A considerable amount of data had been assembled by us as shown in Table 1.

Table 1

1.5 μm	- mean diameter of dust particle
4 μm	- mean diameter of tissue cell
1 g/cc	- density of tissue
2 g/cc	- density of dust particle
1 g	- mass of epithelial tissue
10.6 Bq/cc	- specific activity of dust
5.3 MeV/dis of Pu alphas	
0.00449 cm	- range of α particles
6.62×10^{-9} Bq/cc	in Merlin home
2.3×10^7 cc/day	- adult male breathing rate
T_b	= 100 days, $\lambda = 2.53 \text{ y}^{-1}$
f_a	= 0.0025
12 hr/day in home	

Radford also had obtained 0.0147 Sv/y. I developed what I called a differential method. In this pursuit relations were found as follows:

$$\begin{aligned} \text{mass of respirable particle} &= \frac{4}{3} \pi r^3 \rho = \frac{4}{3} \pi (1.5/2 \times 10^{-4})^3 \times 2 \\ &= 3.53 \times 10^{-12} \text{ g} \\ \text{activity of particle} &= 3.53 \times 10^{-12} (\text{g}) \times 10.6 (\text{Bq/g}) \\ &= 3.746 \times 10^{-11} (\text{Bq/particle}) \end{aligned}$$

mass of tissue within range of q' g on dust particle (called an Alpha Range Ball, ARB) = $\frac{4}{3} \pi (4.49 \times 10^{-3})^3 \times 1 = 3.79 \times 10^{-7} \text{g}$
 dose to each ARB = $d = 3.746 \times 10^{-11} \text{Bq/ARB} \times 3.154 \times 10^7 (\text{S/y}) \times 5.3 (\text{MeV/dis})$
 $\times 1.602 \times 10^{-6} (\text{erg/MeV}) \times 1/10^4 (\text{gGr/erg}) \times 20 (\text{Sv/Gr}) \times 1/3.79 \times 10^{-7} (\text{ARB/g})$
 $= 5.294 \times 10^{-5} \text{Sv/y}$

$Q(\text{Bq}) = P/\lambda (1 - e^{-\lambda t}) = P/\lambda$ at equilibrium

$Q(\text{Bq}) = 4.2 \times 10^{-9} (\text{cc/y}) \times 6.62 \times 10^{-9} (\text{Bq/cc}) \times 0.0025/2.53 (\text{y}^{-1}) = 0.0275 \text{Bq}$ in critical tissue

$n = 0.0275 (\text{Bq}) / 3.746 \times 10^{-11} (\text{Bq/part.}) = 7.33 \times 10^8 = \text{no. of ARB's to be squeezed (crushed) into a tissue form (mold)}$

$1(\text{g}) / 3.79 \times 10^{-7} (\text{g}) \text{ in ARB} = 2.64 \times 10^6 = \text{no. of ARB's that can be crushed into a critical tissue form (mold) without overlap (i.e. with multiple occupancy of space in the tissue form)}$

$p = 7.33 \times 10^8 / 2.64 \times 10^6 = 278 \text{ overlap}$

Total dose = $d \times p = 5.29 \times 10^{-5} \text{Sv/y}$ without overlap $\times 278 \text{ overlap} = 0.0147 \text{Sv/y}$. This differential dose calculation of course gives the same result as the commonly used gross dose method. It is not given here or recommended as a substitute but rather as a new perspective. I hope it will be of help to the handful of us who are trying to help those injured by exposure to ionizing radiation as well as a help to the large numbers of health physicists who rally to defend the company or the government on the defense.

When W.T. Ham was president of the Health Physics Society, he asked me to explore ways of making our society more international. I wrote to over 1,000 persons in 35 different countries and received an overwhelming support for a truly international radiation protection association. IRPA's first meeting in Rome, September 7, 1966, was the bringing to fruition of the goal many of us had longed for since health physics began. As IRPA's first president, I was proud of our new organization and now I can be proud again if our members rally to the aid of persons injured by excessive exposure to ionizing radiation as a major responsibility.

References

1. Morgan, K.Z., "Tolerance Concentration of Radioactive Substances," J. Physical and Colloidal Chem. 51, 984, 1947
2. Report of Committee II on Permissible Dose for Internal Radiation, ICRP-2, Perg. Press, 1959
3. Report of Task Group on Reference Man, ICRP-23, Perg. Press, 1975
4. Maximum Permissible Amounts of Radioisotopes in the Human Body and Maximum Permissible Concentrations in Air and Water, NCRP-52, National Bureau of Standards, 1953
5. Recommendations of the International Commission on Radiological Protection, British J. of Radiology, Sup. No. 3, 1955
6. Maximum Permissible Body Burden and Maximum Permissible Concentration of Radionuclides in Air and Water for Occupational Exposure, NCRP 69, Bureau of Standards 1959
7. Recommendations of the International Commission on Radiological Protection, ICRP-26, Perg. Press, 1977
8. Recommendations of the Commission, 1990 with Annexes, Draft Oct. 1990 ICRP/90/MC-13, 1990-10-04
9. Limits for Intake of Radionuclides, Part 1, 1979; Part 2, 1980; and Suppl. to Part 2, 1981; Part 3, 1981 and Suppl. to Part 3, 1982; Vol. 7 and Vol. 8; Part 4, 1988; Index to ICRP-30, 1982, Pergamon Press
10. Annual Limits on Intake of Radionuclides by Workers Based on the 1990 Recommendations, ICRP-61, Pergamon Press, 1991

PARAMETRES RESPIRATOIRES POUR LA PROTECTION RADIOLOGIQUE

M. Roy,

CEA/Institut de Protection et de Sûreté Nucléaire
Département de Protection de la Santé de l'Homme et de
Dosimétrie, BP 6, 92265 Fontenay aux Roses Cedex, France
M.H. Becquemin, A. Bouchikhi, J.F. Bertholon
Groupe Hospitalier Pitié-Salpêtrière, E.F.R.,
75651 Paris Cedex 13, France.

La dosimétrie des radionucléides inhalés a besoin de valeurs de dimensions des voies aériennes et de volumes d'air respirés chaque jour par les personnes exposées aux gaz et aux aérosols. A l'aide de données récentes fournies par des enquêtes socio-économiques et par la physiologie respiratoire des valeurs standards ont été rassemblées pour des individus-types de la population : travailleur adulte, personne au foyer, enfants de 3 mois, 1, 5, 10 et 15 ans. Ces paramètres peuvent être adaptés à différents groupes de la population mondiale.

RESPIRATORY PARAMETERS FOR RADIOLOGICAL PROTECTION

Dosimetry of inhaled radionuclides requires informations upon airway dimensions and air volumes breathed every day by people under exposure to gases and aerosols. Using recent data of economic surveys, and of respiratory physiology, modern standards have been tabulated for specific categories of a population: adult worker men and women, housewives, children 3 months and 1, 5, 10 and 15 years old. These parameters can be adapted to various population groups in the world.

INTRODUCTION

Dans ses publications 23 et 50 (1,2), la Commission Internationale de Protection Radiologique (CIPR) recommandait pour l'individu standard caucasien, adulte homme et femme, enfant nouveau-né et âgé de 10 ans, des dimensions et des paramètres ventilatoires repris ensuite par les rapports 1982 et 1988 de l'UNSCEAR. Lors de l'élaboration de son nouveau modèle de dosimétrie des voies respiratoires, la CIPR a souhaité actualiser ces données, les préciser pour les adultes et les enfants aux âges définis dans sa publication 56 (3 mois, 1,5,10 et 15 ans) (3) et pour les populations ne se satisfaisant pas des standards caucasiens.

DIMENSIONS DES VOIES AERIENNES

Les volumes et surfaces respiratoires sont liés à la taille corporelle dont la croissance, plus ou moins rapide, se termine à l'âge adulte par des valeurs variables selon les régions du monde. Ces relations n'ont pas partout la même forme. Un exemple en est donné par les régressions de la capacité résiduelle fonctionnelle (CRF) (4), (utilisée en

dosimétrie comme indice du volume alvéolaire) en fonction des tailles chez l'homme adulte. On retrouve aussi de telles différences chez enfant. Dans la plupart des pays, les valeurs biométriques et fonctionnelles ont été établies par les spécialistes et sont prêtes pour la modélisation pulmonaire.

PARAMETRES VENTILATOIRES

Les volumes courants, fréquences respiratoires et débits de ventilation sont probablement un peu différents selon les régions car les besoins individuels en oxygène dépendent du volume corporel. Malheureusement les observations détaillées, aux différents âges, au repos et à l'exercice, n'existent que chez les Caucasiens. Dans les autres populations, les comparaisons que l'on peut faire sur les rares données montrent que les volumes courants et les fréquences varient souvent en sens inverse et que le débit ventilatoire reste assez constant dans notre espèce (5,6). Il est donc raisonnable d'adopter, au moins provisoirement, les mêmes standards pour l'ensemble des populations.

EMPLOIS DU TEMPS

La plupart des enquêtes dans ce domaine ont été publiées dans les pays occidentaux (7). Plus récemment, des études économiques très complètes ont permis d'établir, pour la population française, les occupations journalières des adultes, travailleurs ou personnes au foyer, et des enfants de divers âges (8, 9). Le lieu où se situent ces activités a aussi été défini. Ces données sont surtout valables pour les pays industrialisés qui jouissent d'un climat tempéré. Dans les autres régions du monde, il est possible que l'emploi du temps général (travail, loisirs, sommeil) soit assez voisin mais que les activités journalières se déroulent dans un environnement particulier (extérieur, montagne, habitats spécifiques, etc...) et que des études locales soient nécessaires pour les préciser.

VENTILATIONS JOURNALIERES

En attendant de pouvoir disposer de données complètes sur les diverses populations, et pour obtenir au moins pour un groupe d'individus, un ensemble cohérent de valeurs, aux emplois du temps précédents ont été associés, pour les activités décrites, les paramètres ventilatoires des Caucasiens, très proches de ceux des autres groupes de population. Pour l'homme adulte on a donc défini quatre niveaux standards d'exercice : sommeil, repos assis, exercice léger et exercice violent (10, 11). Les valeurs correspondantes, pour la femme et les enfants aux différents âges, ont été fournies par des données fonctionnelles (12, 14). Finalement on a obtenu les volumes d'air journaliers respirés par les adultes et par les enfants.

CONCLUSION

La précision de la dosimétrie des radionucléides inhalés peut être améliorée par l'introduction de paramètres respiratoires spécifiques de chaque groupe d'individus, selon leur âge, leur sexe et leur emploi du temps. Pour les différentes populations on connaît assez bien les dimensions pulmonaires et on admet que les paramètres ventilatoires varient peu, mais pour l'emploi du temps et les ventilations journalières, les standards occidentaux sont utilisés par défaut. La connaissance des valeurs réelles propres à chaque contrée constituerait ici un progrès sensible.

BIBLIOGRAPHIE

1. ICRP Publication 23, 1975, Reference Man. Pergamon Press, Oxford.
2. ICRP Publication 50, 1987, Lung Cancer Risk from Indoor Exposure to Radon Daughters, Pergamon Press, Oxford.
3. ICRP Publication 56, 1989, Age-dependent Doses to Members of the Public from Intakes of Radionuclides Part. 1, Pergamon Press, Oxford.
4. Quanjer, P.H. Ed., 1983, Standardized Lung Function Testing, Bull. Eur. Physiopathol. Respir., 19: Suppl. 5, 94 p.
5. Chen Xin An, 1988, The Growth and Development of Chinese Students, ICRP Reference Person Task Group Meeting, France.
6. Kamat, S.R., Sarua, B.S., U.R., Venkataraman et al. 1977, Indian norms for Pulmonary function, Assoc. Phys. India, 25: 531-540.
7. Brown, L., 1985, National radiation survey in the U.K.: Indoor occupancy factors, Rad. Prot. Dosimetry 5: 203-208.
8. INSEE, 1988, Contours et Caractères. Les jeunes de 15 à 24 ans.
9. INSEE, Roy, C., 1989, La gestion du temps des hommes et des femmes, des actifs et des inactifs, Economie et Statistiques, 223.
10. Scherrer, J., 1981, Précis de Physiologie du Travail - Notions d'Ergonomie, Masson, Paris.
11. Cotes, J.E., 1979, Lung Function Assessment and Application in Medicine, Blackwell Scientific Publications, Oxford.

12. Flandrois R., Grandmontagne, H., Mayet, M.H., Flavier R. et al., 1982, La consommation d'oxygène maximale chez le jeune Français, sa variation avec l'âge, le sexe et l'entraînement, J. Physiol. Paris, 78, 184-194.
13. Gaultier, C., 1978, Développement des volumes pulmonaires pendant les 36 premiers mois de la vie chez l'homme Doctorat en Biologie Humaine, CHU St-Antoine, Paris.
14. Gaultier, C., Perret, I., Boule, N., Buvry and Girard, A., 1981, Occlusion Pressure and Breathing Pattern in Healthy Children, Respir. Physiol. 46: 71-80.

REMERCIEMENTS

Ce travail a été fait avec l'aide de la Commission des Communautés Européennes. Contrat 890029 B16-0347 - item 2 "Inhalation et ingestion des radionucléides".

PERSONNEL NEUTRON DOSIMETRY IN BRAZIL: 7 YEARS EXPERIENCE

C.L.P. Maurício and E.S. Fonseca

Instituto de Radioproteção e Dosimetria
Comissão Nacional de Energia Nuclear
22780 - Rio de Janeiro - RJ - Brazil

ABSTRACT

The Brazilian neutron personnel monitoring service has been in operation since 1983, and nowadays monitors about 200 workers monthly. It uses an albedo type dosimeter with ^6LiF and ^7LiF TLDs. About 4% of dosimeters evaluated presented some neutron dose (> 0.20 mSv). The majority of these doses, some of which were quite high (12 mSv maximum), were received by people that work with Am-Be sources for oil prospection and research including calibrations). The obtained results in routine, intercomparisons (accuracy within -30% to $+43\%$) and calibrations show that the Brazilian albedo dosimeter system is appropriate for the national neutron fields.

INTRODUCTION

Since November 1983, the Instituto de Radioproteção e Dosimetria (IRD) has operated routinely the Brazilian neutron personnel monitoring service. Nowadays it monitors monthly about 200 workers in the areas of research and power reactors, accelerators, well logging, moisture gauges and Am-Be sources used for calibration and research activities.

Over these years the albedo neutron system has been improved. The evaluation has been computerized, allowing a better quality control, including some error messages¹. Several field calibrations have been made and the single sphere technique² was adopted since 1989³. Besides, for quality guarantee, IRD albedo system has participated since 1985 in international intercomparisons and is periodically recalibrated with certified Am-Be sources.

BRAZILIAN NEUTRON DOSIMETRY SYSTEM

The IRD albedo capsule consists of a semi-spherical polyethylene part covered by boron and aluminium with a place for one pair of commercial $^6\text{LiF:Mg,Ti}$ (TLD 600) and $^7\text{LiF:Mg,Ti}$ (TLF 700) $3 \times 3 \times 0,9$ mm³ chips from Harshaw Chemical Company⁴. The TL dosimeters are evaluated in a Telecyne TLD reader 7300C connected to a clone IBM PC/XT microcomputer¹. This connection, home made in 1989, allows a computerised TLD glow curve analysis, necessary for better quality control in albedo neutron dosimetry.

For dose equivalent assessment, ^{60}Co calibration factors are used for TLD 600 and TLD 700. The neutron dose equivalent is calculated by multiplying the normalized readout difference (TLD 600 - TLD 700) to a field calibration factor (CF)⁵. This factor is necessary due to the high energy dependence of the albedo dosimeter. Each monitored person uses a belt with two albedo capsules attached symmetrically to reduce the dosimeter - body distance effect and to correct the angular dependence⁶.

As the IRD albedo capsule has only one component (albedo TLD pair), it is impossible to identify any neutron field change, making necessary a precious evaluation of the calibration factor, which may vary from 0,04 to 2,2 mSv/mSv ^{60}Co for the Brazilian occupational neutron fields (table 1).

RESULTS

Table 1 shows a summary of the measured doses in the different work places. The majority of monitored people work in oil propection, where a higher dose incidence percentage is found (7%). The second highest dose incidence (6%) is found in research and calibration using Am-Be sources, with the highest dose measured up to now (12,00 mSv).

Table 1 - Dose equivalent levels and calibration factors for the Brazilian work places.

Work place	CF (mSv/mSv ^{60}Co)	H ₂ ≥ 0.2 mSv* (%)	Number of employees	H _{max} (mSv)
well logging	2.2	7	84	2.40
moisture gauge	2.2	2	36	2.30
power reactor	0.04	0.5	30	0.30
research				
AmBe sources	2.2	6	23	12.00
reactor	0.04	0	2	
cyclotron(control room)	0.23	1	11	0.70
TOTAL		4	186	

* 0.20 mSv = register level

Since 1985, the IRD has taken part in all the Personnel Dosimetry Intercomparison Studies (PDIS) promoted by the Dosimetry Application Research (DOSAR) facility staff of the Oak Ridge National Laboratory (ORNL), USA. The results obtained, excluding non perpendicular irradiation incidence (due to a negligible angular dependence) are shown in table 2.

As it is mentioned above, the IRD albedo system needs a previous calibration factor evaluation for each neutron field. Because of this, when the albedo is irradiated for the first time in a different neutron field, it is impossible to make a correct dose evaluation, even with informations of near neutron energy. This explains the high discrepancies obtained in PDIS 11 (first irradiation with the HP RR), in PDIS 12 (first irradiation with Pu-Be source) and in PDIS 16 (first irradiation in a 14 MeV neutron beam). For the $^{252}\text{Cf}(\text{D}_2\text{O})$ field, good agreement was obtained since the first irradiation in PDIS, because the IRD albedo dosimeter was already calibrated for this field.

Table 2 - Performance of Brazilian albedo neutron dosimeters at Personnel Dosimetry Intercomparison Studies (PDIS/ORNL).

Neutron field	$H_{\text{IRD}}/H_{\text{reference}}$ (neutrons)					
	PDIS11	PDIS12	PDIS13	PDIS14	PDIS15	PDIS16
HP RR	1.90	0.85				
HP RR (13 cm steel)	1.51	0.76				
HP RR (12 cm lucite)	0.98	1.02				
HP RR (20 cm concrete)	1.46					
HP RR (lucite + ^{137}Cs)		0.93*				
HP RR (steel + lucite + concrete)		0.97*				
$^{238}\text{PuBe}$		0.58*	1.15	1.43	1.05	0.74
$^{252}\text{Cf}(\text{D}_2\text{O})$			0.94** 0.87	0.72** 0.84	1.40	0.78
$^{252}\text{Cf}(\text{D}_2\text{O})$ without Cd				0.91		
^{252}Cf (polyethylene) + ^{137}Cs				0.70		
$^{252}\text{Cf}(\text{D}_2\text{O})$ + ^{137}Cs					1.41	1.03
^{252}Cf + $^{252}\text{Cf}(\text{D}_2\text{O})$ accelerator (14 MeV)					2.80*	0.33

* Radiation fields unknown to participants prior to evaluation.

** Two different irradiation, for low (< 1 mSv) and high dose (> 1 mSv).

Except for one mixed unknown spectra of PDIS 15 (^{252}Cf - $^{252}\text{Cf}(\text{D}_2\text{O})$), the other results of IRD albedo system are accurate to within - 30% to + 43% of the reference values. In PDIS 14, even for a new field (^{252}Cf (polyethylene)), an acceptable agreement in dose evaluation was achieved. As the albedo was already calibrated with ^{252}Cf sources with different other shields, in this case, it was possible to estimate the calibration factor⁵.

The measured standard deviations of the dosimeters irradiated in each field (normally three) in the PDIS vary from 0 to 17% for neutron equivalent doses in the range of 0,31 to 6,00 mSv. In 70% of the dose evaluation a standard deviation smaller than 10% has been achieved.

CONCLUSION

The results show that the brazilian albedo dosimeter system presents a good performance and is appropriate for all the national neutron fields already tested. The routine results show the importance of individual neutron monitoring and the need of a critical analysis of the neutron work routines, with the aim of checking the possibility of dose reduction, mainly in the areas with doses higher than the recommended levels.

Brazil has no tradition in neutron individual monitoring as it has in photon monitoring. Therefore many brazilian workers occupationally exposed to neutrons still don't wear any kind of neutron dosimeter. It is necessary to know all these work places and evaluate each neutron spectra and local albedo calibration factor. And, finally, to include neutron dosimetry in the Brazilian radiation protection norms and standards.

REFERENCES

1. Maurício C.L.P., Becker, P.H.B. and Kasprzykowski, C.F.A., 1990, TLD Data Acquisition and Analysis System for Neutron Individual Monitoring, Rad. Prot. Dosim. 34, No.1/4, pp. 161-163.
2. Piesch, E., Burgkhardt, B. and Comoer, W., 1985, The Single Sphere Albedo System - A Useful Technique in Neutron Dosimetry, Rad. Prot. Dosim. 10, No.1/4, pp. 147-157.
3. Fajardo, P.W., 1991, Levantamento do Espectro de Nêutrons em Torno do Ciclotron do IEN/CNEN - Calibração de um Dosímetro Pessoal de Nêutrons, master thesis, Physics Department, UFRJ, Rio de Janeiro, Brazil, 75 pages.
4. Carvalho, W.B.D., Burger, G. and Reis, D.C.C., 1977, Personnel Monitor for Neutrons Based on the Albedo Technique, Proc. 5th Int. Conf. on Luminescence Dosimetry, São Paulo, pp. 441-445.
5. Maurício, C.L.P., 1987, Dosimetria Individual de Nêutrons, IRD-CNEN - NT - 014/87, 43 pages.

MODELS FOR THE ASSESSMENT OF INTERNAL DOSE AND IMPLICATIONS FOR THEIR PRACTICAL APPLICATION

J A B Gibson, R K Bull and R C Carpenter

AEA Environment and Energy, B364, Harwell Laboratory
Oxon, OX11 0RA, UK

ABSTRACT

Current problems in internal dosimetry arise from limitations in both the practical techniques available and the biokinetic models which are used to convert monitoring data into estimates of intake and dose. In this paper we discuss these problems and their possible resolution via new developments in measurement techniques and modelling. Intercomparison exercises can be used to help standardise internal dosimetry methods and computer systems can provide databases of dosimetric information and expert assistance in the assessment process. These developments should aid the Europe-wide acceptance of dose records. The implications for internal dosimetry of ICRP 60 are discussed.

MEASUREMENTS

(i) Air sampling. Personal air samplers (PAS) and static air samplers (SAS) provide sensitive measurements of airborne contamination. However gradients in aerosol concentrations can result in differences in aerosol collection by nose/mouth and sampler of a factor ~2-3, though these differences are reduced for long sampling periods (1). Also, an annual limit of intake (ALI) for, say, ^{239}Pu , corresponds to only a few tens of micron-sized particles per m^3 , leading to severe statistical fluctuations in sampling. Whilst a PAS probably gives a good indication of long-term averaged exposure to 'background' levels of airborne contamination, operational experience (2) shows that PAS data are poorly correlated with bioassay results for a discrete intake.

(ii) In-vivo monitoring. In-vivo counting can measure a few becquerels of activity of gamma-emitting nuclides in the whole body or specific locations. Amongst actinides, useful data on lung contents of ^{241}Am can be obtained but ^{239}Pu is not readily detectable at useful levels of activity. The initial ^{239}Pu intake may be inferred from ^{241}Am measurements only if the $^{239}\text{Pu}/^{241}\text{Am}$ ratio is well known.

(iii) Monitoring of urine and faeces. Faecal sampling offers relatively high sensitivity, particularly if carried out shortly after intake. Urine sampling gives much lower sensitivity for many nuclides, including actinides, but gives a measure of systemic uptake. At Harwell, urine analysis can yield a detection threshold of 0.2 mBq/24 h for ^{239}Pu . Despite this sensitivity, intakes of ~20% ALI of insoluble plutonium will remain undetected if they occur mid-way between quarterly urine samples. The new ALI for insoluble ^{239}Pu implied by ICRP 60, will worsen this problem.

At Harwell, routine annual faecal sampling has been introduced to improve our ability to detect actinide intakes. This step introduces its own problems as a faecal sample is

affected by small, very recent, intakes which can mask the longer-term clearance of larger intakes. Ideally, such samples should be given after about one week away from active work. Research is continuing into alternative analytical techniques to improve the detection thresholds for urine analysis. Inductively Coupled Plasma - Mass Spectrometry (ICP-MS) is currently being studied for the detection of very low levels of plutonium in urine. CR-39 plastic alpha track detectors are also being evaluated for long term counting of radiochemically separated actinides from urine.

MODELLING

Excretion may be calculated via either a compartmental model or an excretion function. At Harwell we use the former approach as this allows the retention of activity to be calculated for all conditions. The compartmental model is based on ICRP 30 (3) but, to obtain approximate agreement with actinide excretion functions, it contains dummy compartments holding a small fraction of the activity (4).

(i) The Task-Group lung model. An ICRP Task Group has recently proposed a new lung model (5) designed to allow calculation of doses to respiratory tissues simply and realistically. This model will not be adopted before 1993, but if it is, it will need to be incorporated into biokinetic modelling of radionuclide retention and excretion. It is important that the new model be compatible with available excretion data and to this end we have recently compared a well-documented Harwell actinide case with Task-Group Model predictions (6). The results of this study show (a) that a mechanical clearance component must be included so that faecal excretion decreases monotonically from 10 d to greater than 100 d post intake and (b) that an early phase of enhanced absorption to the transfer compartment should be included.

(ii) New systemic models. ICRP (7) have recently adopted a new model (8) for the bone-liver system in order to calculate age-dependent doses from actinide intakes. This model is more physiologically realistic than previous ICRP (3) treatments of bone and liver. It includes bone growth, remodelling and recycling of activity. General use of this model will lead to changes in doses per unit intake for actinides and hence in ALIs.

(iii) Intercomparisons. Two intercomparison exercises have recently been carried out, in which sets of bioassay and other data have been sent to participating laboratories for assessment. The first was restricted to plutonium intakes and involved only UK laboratories (9). The second covered a wider range of nuclides and involved laboratories throughout Europe (10). Whilst agreement between laboratories was generally good, differences arose from varying statistical treatment of data and the use of different metabolic models. A degree of standardisation of assessment methods will be important, after 1992, when free movement of workers between EEC countries becomes possible and dose records must be compatible.

THE EUROPEAN REGISTRY FOR INTERNAL DOSIMETRY

As a further step towards providing a common European framework for dose assessment, a European Registry for Internal Dosimetry (ERID) has been proposed (11). This will be split into three parts.

(i) ERIDA, a European Registry of Internal Dose Assessments, will use information supplied by European laboratories and obtained from the literature. It will consist of a database containing details of assessments which have features of general interest and will be available as a source of reference for dosimetrists. A prototype version has already been created. Each assessment file will typically contain excretion data, details of modelling and interpretation and references to published material.

(ii) ERAD, a European Registry for Autopsy Data using information obtained by individual laboratories in each European country is being considered following the establishment of a UK autopsy registry which is currently under detailed consideration.

(iii) ERMID, a European Registry of Mathematical Models. This will consist of an expert system written in a 4th generation language for use on an IBM-compatible microcomputer. The system will give access to a suite of models for analysis of excretion/retention data and calculation of doses. It will guide the user through a sequence of steps towards an optimum internal dose assessment, subject to rules governing the changes that can be made to models and model parameters. These rules will limit metabolic changes to those compatible with physiological data from studies of man and animals.

IMPLICATIONS OF ICRP 60

The new recommendations in ICRP 60 (12) will affect ALIs for several reasons:

- (i) Reduction in the annual dose limit from 50 mSv will reduce many ALIs by a factor of 2.5;
- (ii) Deterministic effects will no longer be used to set ALIs in almost all cases;
- (iii) Tissue weighting factors have changed, eg W_T for bone surfaces reduces from 0.03 to 0.01. This, with (ii) above, increases the ALI for class W ^{239}Pu from 200 to 300 Bq.
- (iv) Effective dose is now calculated by summing over all exposed organs and the 10% rule is now dropped.

One practical effect of these changes is that the ALI for class Y ^{239}Pu is reduced from 600 Bq to 300 Bq, further exacerbating difficulties in routine urine monitoring.

CONCLUSIONS

Internal dosimetry will undergo many changes in the next few years. Use of common databases and modelling techniques will result in increasing standardisation of dosimetry methods across Europe. However, changes in lung & metabolic models and dose limits could result in a series of fluctuations in ALIs.

REFERENCES

1. Bull, R.K., Stevens, D.C. and Marshall, M., 1987, Studies of aerosol distributions in a small laboratory and around a humanoid phantom, J. Aerosol Sci. 18, 321-335.

2. Shallcross, R.W., 1989, Practical experience of the assessment of intakes after possible exposure to airborne plutonium. In: Radiation Protection-Theory & Practice. Proc. 4th Int. Symp. of the SRP. pp 235-238.
3. ICRP, 1978, Limits on Intakes of Radionuclides by Workers, Publication 30, Ann. ICRP 2, 3/4.
4. Bull, R.K. & Gibson, J.A.B., 1989, Experiences at Harwell in estimating intakes of actinides. In: Radiation Protection-Theory & Practice. Proc. 4th Int. Symp. of the SRP. pp 215-218.
5. Bair, W.J., 1989, Human respiratory tract model for radiological protection: A revision of the ICRP dosimetric model for the respiratory system. Health Phys., 57, Suppl. 1, 249.
6. Gibson, J.A.B. & Bull, R.K., 1990, The interpretation of bioassay and in-vivo data with the proposed ICRP lung model and the establishment of European registries of internal dose assessments, models & autopsy data. Paper presented at 3rd Int. Workshop on Respiratory Tract Dosimetry, Albuquerque, New Mexico.
7. ICRP, 1989, Age-dependent Doses to Members of the Public from Intake of Radionuclides: Part 1, Ann. ICRP, 20, 2.
8. Leggett, R.W., 1985, A model for the retention, translocation and excretion of systemic plutonium. Health Phys., 49, 1115-1137.
9. Ramsden, D., Birchall, A., Bull, R.K., Foster, P.P., Gibson, J.A.B., Strong, R., Taylor, N.A., Tyler, G.R. and Wraight, J., 1990, Laboratory intercomparison of methods used for the assessment of systemic burdens of plutonium. Radiat. Prot. Dosim., 30, 2, 95-99.
10. Gibson, J.A.B., Birchall, A., Bull, R.K., Henrichs, K., Iranzo, E., Jefferies, S.J., Lord, D.J., Piechowski, J., Sollett, E. and Wernli, C., 1991. A European Intercomparison of methods used for the assessment of systemic burdens of internally deposited radionuclides. In preparation.
11. Gibson, J.A.B., Bull, R.K., Baker, D.M., Hance, J.E., Fry, F.A., Birchall, A., Bailey, M.R. & Piechowski, J., 1991, The assessment of internal dose: the establishment of registries of dose assessment, autopsy data & models. Final Report on Contract: Bi-024.
12. ICRP, 1991, Recommendations of the International Commission on Radiological Protection. Ann. ICRP, 21, 1-3.

ABSOLUTE CALIBRATION OF IN VIVO MEASUREMENT SYSTEMS USING MAGNETIC
RESONANCE IMAGING AND MONTE CARLO COMPUTATIONS

M. W. Mallett,¹ D. F. Eckman,² and D. A. Kruchien²

¹Department of Nuclear Engineering, Texas A&M University,
College Station, Texas

²Hazards Control Department, Lawrence Livermore National Laboratory,
Livermore, California

ABSTRACT

Lawrence Livermore National Laboratory (LLNL) is currently investigating a new method for obtaining absolute calibration factors for radiation measurement systems used to measure internally deposited radionuclides in vivo. This method uses magnetic resonance imaging (MRI) to determine the anatomical makeup of an individual. A new MRI technique is also employed that is capable of resolving the fat and water content of the human tissue. This anatomical and biochemical information is used to model a mathematical phantom. Monte Carlo methods are then used to simulate the transport of radiation throughout the phantom. By modeling the detection equipment of the in vivo measurement system into the code, calibration factors are generated that are specific to the individual. Furthermore, this method eliminates the need for surrogate human structures in the calibration process. A demonstration of the proposed method is being performed using a fat/water matrix.

INTRODUCTION

Current calibration methods for in vivo systems recognize the strong geometric dependence of the process. The validity of the actual counting results is directly related to the similarity of the distribution of radioactivity and absorbing medium used in the calibration procedure to that of the individual being measured. For this reason, surrogate human structures, or phantoms, are used to represent the human body during calibration. A phantom is loaded with a known quantity of radioactivity and then measured by the counting system in a manner representative of human subject measurements. By this means, appropriate calibration factors can be determined for the system.

Much emphasis has been placed upon the development of realistic phantoms. The number of organs included in more recent phantom models has increased, as has their detail with regard to size and shape. More attention has also been given to the use of tissue equivalent materials in constructing phantoms. Despite their increasing complexity, the fundamental problem remains that a phantom represents the "average" characteristics of the human body. Significant corrections must still be made to obtain calibration factors that are applicable to a given individual. Hence, a calibration method is needed that is more sensitive to variability between individuals with regard to anatomical and biochemical differences. A new calibration method being developed at LLNL achieves this objective through the use of MRI.¹

METHOD COMPONENTS

MRI techniques induce a strong, uniform magnetic field throughout the human body, reorienting the spin axis of atoms with magnetic properties. Radiofrequency pulses are then transmitted through the field, perturbing these aligned atoms. Subsequent energy dissipations by the excited nuclei are detected and used to identify the type of tissue being imaged. An anatomical layout of the individual is then determined based on the characteristic resonating patterns of different tissue types.

An advantage of MRI over conventional x-ray imaging techniques (e.g., computed tomography) is that it does not use ionizing radiation and is thus considered to be biologically safe. Additionally, MRI offers biochemical information not obtainable by other imaging modalities. A new MRI method developed at Stanford University improves upon the Dixon technique for obtaining fat and water images.² This method uses a magnetic resonance image that is a measure of the inhomogeneities in the induced magnetic field, B_0 . This information is used to correct the fat, water, and fat plus-water data to yield true fat/water images.

The usefulness of this detailed biological data to calibration procedures is realized by using Monte Carlo methods. The MRI data is used to define a radiation transport medium within a Monte Carlo code. Various tissues or organs of the body are selected as containing sources of radioactive material. Radiation detectors and their location relative to the radioactive material are then modeled into the code. The code then simulates the transport of radiation throughout the medium, repeatedly sampling its library of interaction properties for the MRI-determined biological data. Tallies are recorded for each radiation penetrating the detectors. The code thus simulates the calibration of the in vivo measurement system for the particular subject; i.e., performs an individual specific calibration.

The development of this method is being performed using the Monte Carlo code MCNP4.³ The input file format for this code lends itself well to this application, allowing for the definition of a cube representing each voxel of MRI information. The code is available on numerous operating environments, particularly the VAX and PC machines, and has been validated through years of countless users producing credible results. Quality assurance studies are planned by comparing results obtained using MCNP4 with those produced by other codes, namely MORSE and FGS4.⁴

DEMONSTRATION OF METHOD

The calibration method was demonstrated using a fat/water matrix. The sample was composed of a beef rib bone, sponge, and deionized water enclosed in a polypropylene container (see Fig. 1). A small plastic vial containing natural uranium (1.38 kBq ^{238}U) in solution was also present. The enhanced Dixon images were obtained using a General Electric 1.5-T SIGMA unit. Coronal plane images were made for a 3-mm slice, 24 cm field of view. Figure 2 displays the fat, water, and B_0 images generated.

The Monte Carlo code calculations proceed as follows. The integer data for each magnetic resonance image are reformatted into an acceptable input file for the MCNP4 code. Material specifications are made for each voxel based on a decision tree comparing the ratios of the integer values in the fat, water, and fat plus-water images. Detector systems must also be modeled into the code in an identical manner to the actual counting system used. Tallies record the energy spectrum of protons entering the detector's sensitive volume.

Calculation of calibration factors requires an additional Monte Carlo operation. A single point source, in this case the sample vial of natural uranium described above, is counted by the detector system in the absence of any additional attenuating medium. The layout is also modeled into MCNP4 and processed by the code. Resulting tallies, when divided by the activity of the source, measure the intrinsic efficiency of the detection system. This factor must be included in the final determination of calibration factors for the in vivo measurement system.

DISCUSSION

The method's demonstration has pointed to three areas that require further review. First, the MRI data for multiple slices may exceed the memory capacity of the computer running MCNP4. Each slice is composed of 256×256 , 2-byte integer data. The method requires three Dixon images per slice; i.e., fat, water, and fat-plus-water. Assuming a conservative 1-cm slice thickness, the memory requirements for the MRI data alone for the adult lung region could approach 18 mega bytes. Hence,

the computer's memory may be taxed by the MCNP4 input file considering the additional geometry and material specifications required. Towards this end, we are researching optimization of the computer hardware; i.e., extending computer memory. Another solution is the addition of adjacent voxels of similar tissue type. Convolution techniques such as 5-point and 9-point smoothing can be used to efficiently encode the input files. However, the reduced sensitivity from joining like voxels must also be investigated.

A second issue to be considered is the defining of organ boundaries within the MCNP4 code for assigning source distributions. A likely solution will be the use of an algorithm using the Laplacian technique for automatic edge detection. This also raises the third topic of concern, which is defining the source location within the tissue and organs of the individual. Uniform distribution within the lung tissue is the principal mode of calibration and will be the standard in developing this method. However, the input file to MCNP4 can easily be revised to accommodate whatever source distribution is desired.

This new method will be verified using a specially designed phantom. This phantom will be constructed of a plastic that can be imaged by MRI techniques. Various compartments within the phantom will be available for redistributing radioactive sources and absorbing media while providing a method for consistently reproducing measurement results. Additionally, a MRI data base of human volunteers, selected on the basis of varied body sizes and shapes, is being compiled. This data base will be used to assess the validity of a correlation between biometric data for an individual (e.g., height, weight, and chest-wall thickness) and the calibration method described here.

ACKNOWLEDGMENT

This research is being performed under appointment to the Nuclear Engineering and Health Physics Fellowship program administered by Oak Ridge Associated Universities for the U.S. Department of Energy.

This research is supported by the U.S. Department of Energy by the Lawrence Livermore National Laboratory under Contract No. W 7405 Eng 48 and by the U.S. Nuclear Regulatory Commission under Contract No. 60-91-348.

REFERENCES

1. Kruchten, D. A., and D. P. Hickman (1991), *Absolute Calibration of In Vivo Measurement Systems*, OORL 10 106311, Lawrence Livermore National Laboratory, Livermore, CA.
2. Glover, G.H., and E. Schneider (1991), "Three Point Dixon Technique for Free Water/Fat Decomposition with B_0 Inhomogeneity Correction," *Magnetic Resonance in Medicine* **18**, 371-383.
3. Briesmeister, J.F. (1991), *MCNP - A General Monte Carlo Code for Neutron and Photon Transport*, LA 7396-M, Los Alamos National Laboratory, Los Alamos, NM, rev. 4.
4. MORSE and EGS4 computer codes, distributed by Radiation Shielding Information Center, Oak Ridge National Laboratory, Oak Ridge, TN.



Figure 1. The fat/water matrix (sagittal plane) is composed of a beef rib bone, two sponges, and a plastic vial containing 1.38 kBq U^{238} in solution. The container is composed of polypropylene and filled with deionized water.

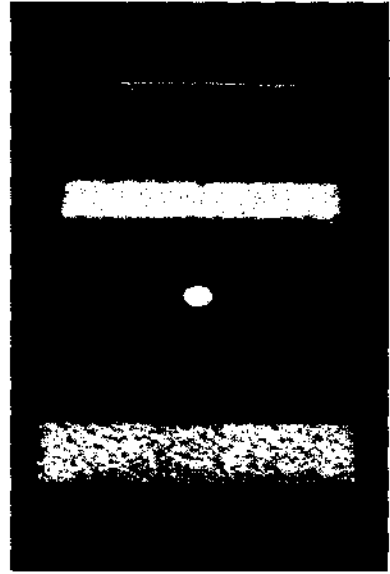

(a)



(b)



(c)

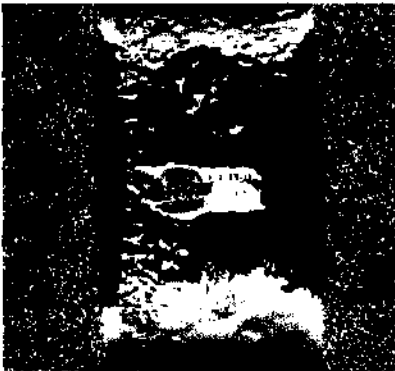

Figure 2. Enhanced Dixon images (coronal plane) of the fat/water matrix. (a) fat, (b) water, (c) B_0 .

RECENT DEVELOPMENTS IN IN-SITU γ SPECTROMETRY

P. Jacob and R. Meckbach
GSF-Institut für Strahlenschutz, D-8042 Neuherberg, Germany

ABSTRACT

The objective of the present contribution is to improve standard in-situ γ spectrometry by two means: First, results of post-Chernobyl measurements of the attenuation of radiation from cesium, ruthenium, barium and iodine isotopes on lawns and meadows are presented, allowing to derive representative values of the attenuation of radiation for different time periods after deposition. Second, a method has been developed to derive the actual attenuation of the radiation from the measured spectrum by comparing the fluences of photons with different energies from single radionuclides. The application to 16 spectra demonstrates an obvious improvement of standard in-situ γ spectrometry.

INTRODUCTION

In-situ γ spectrometry has become a standard method for rapid determination of radionuclide activities in and on the ground. The accuracy of the results of standard in-situ γ spectrometry is limited by the fact that the method is based on an assumption of the gamma radiation attenuation by the soil. This attenuation is due to the surface roughness of the ground and to the depth distribution of the radionuclides in the soil.

In the first part of this contribution results of post-Chernobyl measurements of the radiation attenuation of different radionuclides are presented. These data may contribute to an assessment of appropriate attenuation parameters for standard in-situ spectrometry. In contrast to results from measurements of depth profiles, the presented data contain also the attenuation by the surface roughness.

The difference of the attenuation of the gamma radiation at different sites increases in general with the time after deposition⁴. Since in the standard method of in-situ γ spectrometry in general the same value of attenuation is assumed for all measurements over lawns in the same period of time, the uncertainty of the results also increases with time. Several groups are trying to improve this shortcoming and some results have already been published⁵⁻⁷. The presented methods use information contained in the measured spectrum to derive the attenuation of the unscattered radiation. They fall into two categories based on different effects:

(i) the ratio of the scattered radiation to the unscattered radiation increases with the attenuation of the radiation, and
(ii) the attenuation of the unscattered radiation depends on photon energy. Unfortunately, the results published up to now are either purely theoretical, have systematic deviations from soil samples, or are based on a very limited number of measurements, also burdened by some obscurities.

It is the aim of this contribution to explicitly demonstrate the possibility of improving in-situ γ spectrometry by a method of category (ii) as mentioned above. The method is applied to Cs-137, whose daughter nuclide Ba-137m emits photons with energies of 662 keV and of about 32 keV. The attenuation of photons with these two energies can be expected to be sufficiently different to allow an identification of the total attenuation. The method is applied to 16 spectra which have been recorded in the first half year after the reactor accident of Chernobyl and results are compared with activities per area which have been obtained by measurements of soil samples.

ATTENUATION OF UNSCATTERED RADIATION

The attenuation of the unscattered radiation over lawns and meadows was measured by the following method:

First, at each site 6 soil samples have been taken, each consisting of 5 soil cylinders, 15-20 cm deep and with a ground surface of 18 cm². The 5 cylinders have been taken from the edges and the center of a 10x10m square. Results for Cs-134 are given in Table 1. It may be assessed that 0.6-1.2 kBq·m⁻² of the Cs-134 activity were due to dry deposition and that the largest part was deposited during a wet deposition with a precipitation in the order of 5-15 mm (with the exception of the site Giglberg)⁹.

Site	Neuherb.	Neuhaus	Aurach	Giglberg	Grafin	Bad Reichenh.
activity per area (kBq·m ⁻²)	9.9±0.4	25.2±2.4	17.0±1.2	4.0±0.2	25.8±0.7	20.3±1.3

Table 1. Deposited Cs-134 activity as determined by soil sample including vegetation. The uncertainty bounds give the standard deviation of the mean value.

Second, in-situ γ spectrometry was performed at a height of 1 m above the center of the square, used for the soil sampling. The ratio of the measured unscattered photon fluences to the calculated unscattered photon fluence at a height of 1 m above a plane source with an activity as given in Table 1 on a smooth air-ground interface expresses the attenuation of the radiation due to surface roughness and migration into the soil. Results are presented in Table 2. Uncertainties of the results were derived from those given in Table 1 and from the uncertainty due to counting statistics as calculated by the analysis software (SPECTRAN F). The latter was multiplied by a factor of 1.2 to obtain the uncertainty of the measurement of unscattered photon fluences. The factor 1.2 was obtained in a series of test measurements for the range of some hundred keV to some MeV.

Measurement		Attenuation of unscattered radiation			
Site	Date	I-131 365 keV	Ru-103 498 keV	Cs-134 796 keV	Ba-140 1596 keV
Neuherberg B	04 June	0.52	0.47	0.57	0.62
Neuhaus	04 June	0.62	0.59	0.62	0.61
Neuherberg C	09 June	0.65	0.55	0.68	0.73
Aurach	10 June	0.75	0.62	0.64	0.70
Giglberg	10 June	(0.72)	0.56	0.67	(0.70)
Neuherberg B	03 July	-	0.52	0.60	-
Neuherberg C	03 July	-	0.56	0.65	-
Grafin	04 July	-	0.36	0.49	0.50
Neuhaus	17 July	-	0.71	0.73	-
Aurach	17 July	-	0.57	0.58	-
Neuherberg B	08 Sep	-	0.42	0.53	-
Grafin	23 Sep	-	0.30	0.41	-
Neuhaus	30 Sep	-	0.68	0.64	-
Aurach	30 Sep	-	0.50	0.52	-
Bad Reichenhall	09 Oct	-	0.50	0.54	-
Neuherberg A	15 Oct	-	0.56	0.66	-

Table 2. Attenuation of unscattered radiation as derived from measurements of soil samples and in-situ γ spectrometry at several lawns and meadows in Southern Bavaria in the year 1986. The calculated uncertainty of the given values corresponds to a standard deviation less than 15 %, for values in parentheses less than 20 %.

The values in Table 2 are similar for all of the radionuclides given, only the radiation of Ru-103 is about 10 % more attenuated than the radiation of the other radionuclides. This result is in accordance with measurements of depth profiles [10,11].

With the exception of the site Neuhaus, which is a relative wet meadow in a (smooth) valley in the Alps, the attenuation depends clearly on the amount of precipitation during the deposition, which may be assessed from the deposited activities. In the case of Cs-134 the attenuation ranges from about 0.5 for Grafing und Bad Reichenhall to about 0.7 for Giglberg.

IN-SITU DETERMINATION OF ATTENUATION

The ratio of fluence rates of unscattered photons with different energies but emitted from the same radionuclide depends as shown in Table 3 for Cs-137 on the depth distribution. The ratio of the corresponding count rates of a typical portable detector system has a comparable sensitivity on the depth distribution parameter. This fact has been used to determine from measured photon spectra the depth distribution parameter and the activity per area⁸.

Relaxation mass per area ($g \cdot cm^{-2}$)	Ratio of fluence rates for 32 keV and 662 keV	Ratio of count rates for 32 keV and 662 keV
0.1	0.54	0.076
0.2	0.48	0.069
0.3	0.43	0.064
0.5	0.38	0.058
1.0	0.31	0.048
2.0	0.24	0.038
3.0	0.21	0.033
5.0	0.17	0.028
10	0.14	0.023

Table 3 Ratio of fluence rates at a height of 1 m above ground for 32 keV and 662 keV photons emitted by Ba-137m with an exponential distribution in soil. The third column gives the corresponding ratio for count rates as detected by a N-type high purity Germanium detector (Canberra) with a relative efficiency of 25 %.

Measurement		Cs-137 activity per area ($kBq \cdot m^{-2}$)		
Site	Date	Soil sampling	In-situ γ spectrometry	
			proposed method	standard ($1.5g \cdot cm^{-2}$)
Neuherberg B	08 Sep	18	15	19
Grafing	23 Sep	47	56	38
Neuhaus	30 Sep	39	47	47
Aurach	30 Sep	33	29	18
Bad Reichenhall	09 Oct	38	34	42
Neuherberg A	15 Oct	18	16	24
relative deviation from soil sampling			0.97±0.15	1.00±0.28

Table 4 Cs-137 activity per area ($kBq \cdot m^{-2}$) in the period September/October 1986 derived by soil sampling, by the method proposed and by the standard in-situ γ spectrometry using a depth distribution in the soil which has been optimized according to the results of the soil sampling.

The method has been applied to post-Chernobyl spectra⁸ and some results are shown in Table 4. The proposed method agrees well with the results of the soil sampling. Concerning standard in-situ γ spectrometry a value for the depth distribution parameter has to be assumed. Table 4 shows that the average deviations of the standard method from the results of the soil sampling are considerably higher than for the proposed method, even if a depth distribution parameter is assumed, which is optimized for the given situation so that the mean value of the deviation is zero.

REFERENCES

1. Beck, H.L., Condon, W.J., Lowder, W.M., 1972. Spectrometric Techniques for Measuring Environmental Gamma Radiation. Report HASL-150, US Atomic Energy Commission, New York, NY 10014.
2. Beck, H.L., DeCampo, J., Gogolak, C., 1972. In situ Ge(Li) and NaI(Tl) Gamma-ray Spectrometry. Report HASL-258, US Atomic Energy Commission, New York, NY 10014.
3. Helfer, I.K., Miller, K.M., 1988. Calibration Factors for Ge detectors used for Field Spectrometry. Health Phys. 55:15-29.
4. Jacob, P., Meckbach, R., Müller, H.M., 1990. Meinberg, K. Abnahme von künstlicher Radioaktivität nach Deposition in städtischer Umgebung. GSF-Bericht 17/90, GSF, D-8042 Neuherberg, FRG.
5. Sowa, W., Martini, F., Gehrcke, K., Marschner, P., Naziry, M.J., 1989. Uncertainties of In-situ Gamma Spectrometry for environmental Monitoring. Radiat. Prot. Dosim. 27:93-101.
6. Karlberg, O., 1990. In-situ Gamma Spectrometry of the Chernobyl Fallout on urban and rural Surfaces. Studsvik Report NP-89/108, Studsvik Nuclear, 61102 Nyköping, Sverige.
7. Korun, M., Martincic R., Pudelj, B. In-situ Measurements of the radioactive Fallout Deposit. Nucl. Inst. and Meth. A300:611-615, 1991.
8. Rybacek, K., Jacob, P. and Meckbach, R., 1991, In-Situ Determination of Deposited Radonucleide Activities: Improvement of the Method by Deriving Depth Distribution from the Measured Photon Spectra. Submitted to Health Phys.
9. Hötzel, H., Rosner, G., Winkler, R., 1987. Ground Depositions and Air Concentrations of Chernobyl Fallout Radionuclides at Munich-Neuherberg. Radiochimica Acta 41:181-190.
10. Schimmack, W., Bunzl, K. and Zelles, L. 1989. Initial Rates of Migration of Radionuclides from the Chernobyl Fallout in Undisturbed Soils, Geoderma 44, 211-218.
11. Winkelmann, J., Endrulat, H.-J., Fouasnon, S., Gesewsky, P., Haubelt, R., Klopfer, P., Köhler, H., Kohl, R., Kucheida, D., Leising, C., Müller, M.-K., Neumann, P., Schmidt, H., Vogl, K., Weimer, S., Wildermuth, H., Winkler, S., Wirth, E., Wolff, S. 1987. Radioactivity Measurements in the Federal Republic of Germany after the Chernobyl Accident. ISH-Heft 116, Bundesamt für Strahlenschutz, 8042 Neuherberg, FRG.

**BRAZIL AND ARGENTINA WHOLE BODY COUNTERS INTERCALIBRATION FOR
"IN-VIVO" MEASUREMENTS OF AM-241 IN BONE**

Oliveira, C.A.N; Lourenço, M. C.; Dantas, B. M.
Instituto de Radioproteção e Dosimetria-IRD.
Comissão Nacional de Energia Nuclear-CNEN.
Brazil

Righetti, M. and Rojas, C.
Gerencia Seguridad Radiológica y Nuclear-GSRyN.
Comisión Nacional de Energía Atómica-CNEA.
República Argentina

ABSTRACT

This paper presents the outcome of a whole body counter intercalibration exercise carried out jointly by Brazil and Argentina under the frame of a cooperation agreement in the nuclear field. In order to estimate the corresponding calibration factors, a skull phantom contaminated with Am-241 belonging to the brazilian IRD and a mathematical model developed at the argentine CNEA, were used. The results obtained at both facilities showed an excellent correlation.

INTRODUCTION

An intercalibration exercise was performed between Brazil and Argentina whole body counter (WBC) facilities, under the Cooperation Agreement in the nuclear field between both countries. This exercise comprised the intercomparison of the performance of the detection systems for low energy photon emitters.

The long-term intakes of transuranic elements, like Am-241, may be evaluated by the determination of its skeletal burden. In order to estimate the committed dose, it is necessary to determine the Am-241 activity deposited in bone tissue.

The skull presents appropriate characteristics to perform those measurements since: (a) it is relatively easy to shield the head and adjacent detectors from radioactive emissions originating from other areas of the body; (b) there are no organs or soft tissues in close proximity to the skull that significantly concentrate bone-seeking nuclides; (c) it is one of the least anatomically variable structures among subjects of different height and weight; (d) it is possible to surround the head, almost entirely, with detectors, thereby improving the geometry for "in vivo" assay and minimizing the effects of possible head movement on the detection efficiency [Co76].

Both, a physical model and a mathematical model were used. The former was based upon a skull phantom while the latter consisted in the application of the Monte Carlo method to the photon transport in a MIRD-V phantom.

PHYSICAL MODEL

The skull phantom was constructed by covering a human skull, previously contaminated with Am-241, with a tissue equivalent material to a thickness obtained from available physiological tables.

MATHEMATICAL MODEL

It is based on the application of the Monte Carlo method to the photons transport in the antropomorphic and heterogeneous male phantom MIRD-V, which is a mathematical representation of the ICRP-23 reference man [Ic75, R185, R189].

The trunk is represented by an elliptical cylinder, 70 cm height and diameters of 20 cm and 40 cm. A truncated cone and an elliptical cylinder represent the lower extremities and the head, respectively. The skull is the volume between two nonconcentric ellipsoids with a volume of 846.8 cm³ and a mass of 1.258 g. Source characterization was done by generating a code based upon the random selection of the emission point in the whole volume of the skull.

DETECTION SYSTEM

The detection systems of both facilities consist of two phoswich detectors (Table I). Both systems make use of a pulse shape discrimination technique in order to reduce the background, though they apply it in a different way. The detectors are installed inside shielded rooms, specially designed for performing "in vivo" measurements of low activities of photon emitters. Table II shows some characteristics of the shielded rooms [R184, O185, O189].

Facility	Phoswich Detector			
	No.	diameter	thickness	window
IRD/CNEN	2	127 mm	NaI(Tl) 5 mm CsI 50.8 mm	Al 0.02 mm
GSRyN/CNEA	2	127 mm	NaI(Tl) 3 mm CsI 50.8 mm	Al 0.076 mm

TABLE I

Facility	Dimension [m]				Others characteristics
	high	large	width	thick	
IRD/CNEN	2.5	2.5	2.62	0.15	Steel lined with Pb, Cd, Cu
GSRyN/CNEA	2.3	2.3	1.8	0.15	Iron lined with Pb, Cd.

TABLE II

RESULTS

The skull phantom was measured in both facilities with the detector parallel to each side of the head. A similar configuration was used in the mathematical simulation.

Table III shows the calibration factors and minimum detectable activities (MDA) for both facilities for the 60 keV photopeak of Am-241 [Al63].

Facility	Energy Range [keV]	Calibration Factor [cpm/Bq]	MDA [Bq]
IRD/CNEN	45-65	1.37	1.6
GSRyN/CNEA	47-68	1.33	1.5

TABLE III

Table IV shows the calibration factor obtained for the physical and mathematical models and the relative difference between them.

Model	Calibration Factor [cpm/Bq]	Difference %
Physical	1.33	0.7
Mathematical	1.34	

TABLE IV

CONCLUSIONS

The calibration factors and the MDA calculated with both systems were in close agreement, in spite of the slight differences between them. In addition, the use of the mathemati-

cal model to evaluate the calibration factors is fully justified having into account the excellent correlation found between the simulation models used.

The application of the metabolic model for Am-241 proposed by the ICRP to evaluate activities in body organs [Ic78], shows that the inhalation of one ALI, results in a deposition of about 9 Bq in the whole skeleton, approximately 80 days after the contamination. As the skull represents 18% of the total mass of the skeleton, these systems are sensitive enough as to detect intakes of about 1 ALI.

REFERENCES

Co76 Cohen N., Spitz H.B., Wrenn M., "Estimation of skeletal burden of bone seeking radionuclides in man from in vivo scintillation measurements of the head", Health Phys., 33, 431, 1976.

Ic75 International Commission on Radiological Protection; "Reference man", ICRP Publication 23, Pergamon Press, Oxford, 1975.

Sn79 Snyder V., Ford M., Wagner G., Fisher H., "MIRD-V", Pamphlet Nro 5, Journal of Nuclear Medicine, 1979.

Ri85 Righetti M., Hernandez D., Chagaray J., Spano F., Thomasz E., "Modelo matemático para cálculo de eficiencia en mediciones de 239-Pu y 241-Am:", IAEA-SM-276/63, 1985.

Ri89 Righetti M., Hernandez D., Spano F., "Determination of counting efficiency of phoswich detectors for the assessment of internal contamination in lungs and lymph nodes by using a mathematical model", Nuc. Inst. and Meth., A280, 1989.

Ri84 Righetti M., Bonino A., Hernandez D., Chagaray J., "Calibration of a phoswich system for the in vivo measurement of 239-Pu and 241-Am activities", 6th International Congress, International Radiation Protection Association, Berlin, 1984.

Oi85 Oliveira C.A.N., "Whole body counting installation for assessment of internal contamination in workers", IAEA-SM-276/66, 1985.

Oi89 Oliveira C. A. N., Lourenço M. C., Dantas B. M., Lucena E. A., Bertelli L., and Laurer G. R., "The IRD/CNEN whole body counting facility: background and calibration results", Radiat. Prot. Dosim., 29, 3, 1989.

Al63 Altshuler B. and Pasternack B., "Statistical measures of the lower limit of detection of a radioactivity counter", Health Phys., 9, 293, 1963.

Ic78 International Commission on Radiological Protection; "Limits for Intakes of Radionuclides by Workers", ICRP Publication 30, Pergamon Press, Oxford, 1978.

TOWARDS A RELIABLE DOSIMETRY

A. Badano, C. Curbelo.
Dirección Nacional de Tecnología Nuclear
División Protección Radiológica y Seguridad Nuclear
Uruguay

ABSTRACT

To make certain of the appropriate development of thermoluminescent dosimetry as an essential technical support for the Servicio de Dosimetría Personal (SDP) of the DINATEN, the evaluation of some quality parameters is presented in the paper. Experimental values related to the accuracy and precision are compared with the metrological specifications of the ANSI N13151975. Experimental results are presented with regard to lower limit of detection, determination limit, linearity, homogeneity of the batch of dosimeters, replicability, thermal fading, and other influencing parameters. The conclusion of the evaluation satisfies the requirements of thermoluminescent dosimetry applied to a personal dosimetry system and offers a solid basis for the improvement of the SDP.

INTRODUCTION

The Dosimetry Group of the División Protección Radiológica y Seguridad Nuclear of the DINATEN offers a Personnel Dosimetry Service (SDP) to occupationally exposed to ionizing radiation workers. During the last years, film dosimetry was the main technical support. At the end of 1989, we decided to incorporate thermoluminescence technics (TLD) to the SDP routine. The first step of the implementation was an internal report (1) that summarizes the activities concerning the equipment requirements (2,3,4). Then, so as to make certain of the appropriate development of TLD technic, some quality criteria from analytical laboratory quality control (7) were applied. Their particular application to TL and to personnel dosimetry requirements were discussed. In the present paper, the evaluation of some quality parameters is introduced. Experimental results are compared with the metrological specifications of the ANSI N13.15-1985 (5).

MATERIALS AND MEASUREMENT CONDITIONS

The equipment used was the following: TL dosimeter cards G-1 with two TLD 100 chips (1/8"x1/8"x0.035"), a TL detector model 2000-C and a TL analyser model 2080 from HARSHAW Chem. Co.. A 137-Cs calibrated source TECH-OPS and

a NUCLEAR ENTERPRISE timer model 2546 were used for the dosimeter irradiations. The measurement conditions were(2): preheating temperature 120°C, reading temperature 265°C, photomultiplier tube voltage 684 V, acquisition time 20 s, reading time 15 s, heating time 15 s and preheating time 15 s.

EXPERIMENTAL MEASUREMENTS

The parameters evaluations were carried out under SDP(1) routine conditions. The experiences were performed with random samples of 10, from the SDP dosimeters batch, excepting where indicated.

Accuracy and precision

Table 1 shows acceptable limits of the average and standard deviation of the Performance Index(B and S respectively) specified by ANSI(5), and the calculated experimental results.

Tab. 1: Acceptable limits and experimental results for B and S for doses of 0.1 y 1 mGy.

	B(0.1 mGy)	B(1 mGy)	S
Category 1 (photons from 0.3 to 10 Mev)	≤0.47	≤0.15	≤0.20
Category 2 (photons below 0.3 Mev)	≤0.95	≤0.3	≤0.25
Experimental results	0.12	0.04	0.075

Lower limit of detection and quantification limit

Several criteria have been reported concerning the determination of the lower limit of detection(LLD) and the quantification limit(6,7). Table 2 shows the most usual ones and the experimental calculated results. In figure 1, those limits are presented with the experimental curve of relative standard deviation as a function of dose.

Batch homogeneity

The irradiation of the 250 dosimeter batch with 1 mGy showed a relative standard deviation of 6.5.

Replicability

The relative standard deviation of the responses of the irradiation of one single dosimeter with 0.5 mGy was 2.5.

Other influencing parameters

Several parameters affecting the TL response have been described (i.e. light, storing temperature, incidence angle, radiation energy). To study the effect of natural light on the TL response, dosimeters non irradiated and irradiated to 1 mGy were stored some at obscurity and some exposed to natural light. An increase of the average TL response equivalent to 0.2 µGy per hour of light exposure was observed.

DISCUSSION

Concerning accuracy and precision, LLD, LC, homogeneity, replicability and linearity (not presented in the paper), the experimental results are in agreement with the requirements of a personnel dosimetry system. Additional research seems to be necessary in order to study the thermal fading and the effect of other influencing parameters, particularly dosimeter energy response.

CONCLUSION

The present evaluation satisfies the requirements of TLD applied to a personnel dosimetry system, and offers a solid basis for the improvement of the SDP.

REFERENCES

- (1) M. Trinidad y A. Badano, "Estudios iniciales sobre el diseño del servicio de dosimetría termoluminiscente de la División Protección Radiológica y Seguridad Nuclear", informe interno, DINATEN, dic. 1989.
- (2) M. Oberhofer, "Selection of instrument settings for optimal Harshaw LiF dosimeter card reading", DINATEN, 1982.
- (3) M. Oberhofer, "Quality control for LiF dosimeter card readings with the Harshaw 2080 TLD Analyser System", DINATEN, 1982.
- (4) M. Oberhofer, "Performance check for the modified CNEA-Personel Dosimeter Badge", DINATEN, 1982.
- (5) ANSI N13.15-1985, "Personnel Thermoluminescence Dosimetry Systems-Performance", 1985.
- (6) L. Currie, "Limits for qualitative detection and quantitative determination", Anal. Chem., vol.40, n°3, mar. 1968.
- (7) T. Villar, "Control de calidad en el laboratorio analítico", UNIT, Uruguay.
- (8) "TLD materials and system", Harshaw Chem. Co..
- (9) M. Oberhofer y Sharmann, "Applied thermoluminiscent dosimetry", nov. 1979, ISPRA.

Tab. 2: Criteria and results of LLD and LC.*		
	LLD(mGy)	RSD%
LLD1=2xσb	0.014	28
LLD2=3xσb	0.023	22
LLD3=2xLO	0.058	14
LC=10xσb	0.068	13

*: σb is the standard deviation and LO the average of the zero readings(non exposed dosimeters), with a sample size of 30.

‡: Relative Standard Deviation(RSD) = $\sigma/\mu \times 100$, where σ is the standard deviation and μ the average.

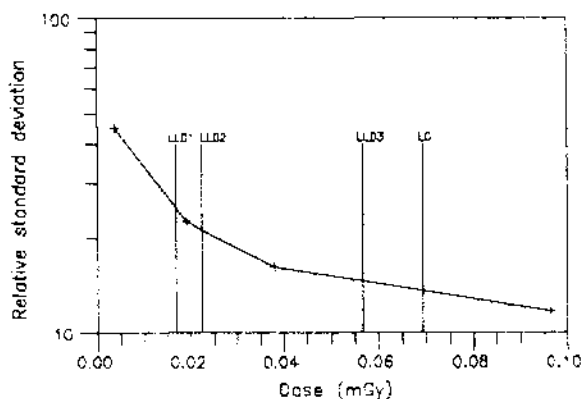

Fig. 1: Determination of LLD and LC

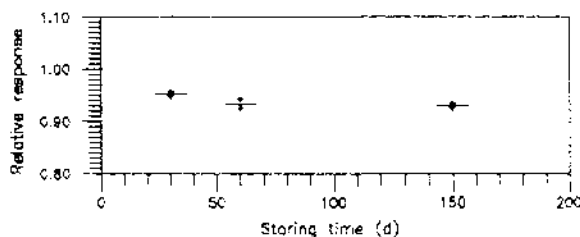

Fig. 2: Thermal fading

Thermal fading

Figure 2 shows the TL response of dosimeters irradiated with 1 mGy as a function of storing time, in normal storing conditions. We observe 10% of fading in 3 months. This result is 2-6 times greater than the reported ones(8,9).

ELIMINATION OF THE RESIDUAL SIGNAL IN LiF:Cu,Mg,P

A. Horowitz
Crystal Growth Division
Nuclear Research Center-Negev, Beersheva, Israel

and

Y. Horowitz
Physics Department
Ben Gurion University of the Negev, Beersheva, Israel

ABSTRACT

Previous studies have reported a significant residual signal in LiF:Cu,Mg,P (GR-200, Radiation Detector Works) which arises from a peak at 270°C with an intensity of 7-50% relative to the main dosimetry peak. We have found a method to prepare LiF:Cu,Mg,P in two forms; one with a TL sensitivity 30-40 times greater than TLD-100 but with a residual signal of only 2-3% following 240°C for 10 seconds readout, the other, even more optimized material, (SSD-NR), with a sensitivity 15-20 times that of TLD-100 but with the 270°C peak almost totally eliminated, leading to a residual signal of 0.25-0.5%.

INTRODUCTION

LiF:Cu,Mg,P is a thermoluminescent (TL) material of exceptional dosimetric characteristics (1). Its Co-60 gamma sensitivity is 15-40 times greater than that of TLD-100 (2,3) and enables ultra-low dose measurements in the microGy dose range far beyond the usual capability of TLD-100. LiF:Cu,Mg,P possesses other advantages. Due to the tendency of the dose response to enter early into saturation LiF:Cu,Mg,P is significantly more "tissue-equivalent" to low energy photons (<150 keV) than TLD-100. For the same microdosimetric reasons, the relative response to high ionization density particles is very low (4,5), and therefore, LiF:Cu,Mg,P can serve as an excellent discriminator against neutrons. Another important advantage is in clinical dosimetry: LiF:Cu,Mg,P shows none of the annoying supralinear properties of LiF:Mg,Ti. Finally, the greatly enhanced sensitivity should allow the fabrication of ultra-thin dosimeters of greatly improved performance in the measurement of superficial dose.

There has been one problematic area in the application of LiF:Cu,Mg,P. Annealing or readout above 245°C leads to an irreversible loss in sensitivity and changes in the glow curve structure (2). The maximum temperature of readout or annealing should therefore be no greater than 240°C (3) to ensure long-term stability and re-useability. In applications where repeated high temperature annealing is unacceptable (most areas of personnel and environmental dosimetry), this restriction leads to a total residual signal of 7-10% (3) and even as high as 30-40% (6) in currently available commercial material.

MATERIALS AND METHODS

Various parameters involving different aspects of the material preparation parameters were varied. These included: (i) The chemical form of the added impurities, (ii) concentration of the added impurities, (iii) parameters of the thermal regime, (iv) process atmosphere and (v) particle size distribution. In the "standard" preparation procedure (7) lithium fluoride powder of optical grade (Merck up 5686) was thoroughly mixed with the following activators: MgF_2 (BDH Magtran powder), CuF_2 (Koch-Light) or $CuCl$ (Atomergic Chemetals) and $NH_4H_2PO_4$ (Merck 1126). The mixture was then heated in a Pt crucible to $1000^\circ C$ under a controlled N_2/O_2 atmosphere in a total gas flow of 3-5 liters/minute. After 30 minutes in the molten stage, the material in the crucible was quenched to room temperature. The glow curve heating rate was $90^\circ C \text{ min}^{-1}$ to $400^\circ C$ in order to readout the entire high temperature TL. The relative areas of the glow peaks were estimated by computerized glow curve deconvolution (CGCD) or alternately by readout to $240^\circ C$ for 10 seconds followed by 5-10 successive readouts to estimate the total residual

EXPERIMENTAL RESULTS

For convenience, and to establish a basis and measure for comparison we have defined a relative figure of merit, RFOM, for "unannealed" $LiF:Cu,Mg,P$ dosimeters given by

$$RFOM = \frac{\text{Sensitivity of peaks (3+4) in } LiF:Cu,Mg,P \text{ relative to peaks (4+5) in TLD-100}}{\text{Ratio of peak 5 to peak (3+4) in } LiF:Cu,Mg,P} \quad (1)$$

Table 1. Effect of forms of phosphate

chemical species	conc. mg	sensitivity relative to TLD-100	ratio: peaks 5/(3+4)	other dopants	RFOM
1. $NH_4H_2PO_4$	3	25	0.45+-0.15	standard	55.5
2. Li_3PO_4	2.5,5	0.2	--	standard	-
3. LiH_2PO_4	5	8.7	0.53	standard	16.4
4. H_3PO_4	3	22.5	0.53	standard	42.5
5. H_3PO_4	3	22.6	0.27	$CuI-0.008M\%$	83.7
6. $H_3PO_4^*$	3	24.7	0.26	$CuI-0.008M\%$	95.0
7. $NH_4H_2PO_4$	3	23.5	0.35	$(NH_4)_2CO_3 + NH_4OH-1M\%$ ea.	67.0
8. $Li_4P_2O_7$	3	8.6	1.09	$CuI-0.008M\%$	7.9
9. $NH_4H_2PO_4$	1.5	10.5	0.76	$CuI-0.008M\%$	13.8
10. $(NH_4)_3PO_4$	3	6.6	0.76	standard	8.7

* Treated at $220^\circ C$ to form polymers

Table 1 shows the results of our investigations on the effect of the chemical form of the added phosphate. These were carried out during earlier studies when we had not yet arrived at the optimal conditions of other starting parameters for the minimization of the high temperature TL. The importance of

acidic hydrogen in the starting phosphate configuration is clearly indicated. On the basis of these RFOM values, and to lower the quantity of effluent gases, we decided to changeover to H_3PO_4 as a starting material. CuI also seemed at this stage to result in lower intensity of high temperature TL. The superiority of H_3PO_4 in reducing high temperature TL was later vindicated by further investigations at optimal conditions. CuI , $CuCl$, and CuF_2 , however, were found to be identical vis-a-vis the creation of high temperature TL. We also found that a small amount of O_2 in the melt atmosphere (0.5-1 M%) reduced the relative intensity of the high temperature TL by a factor two with no adverse affects on the main peak sensitivity. Figure 1 shows glow curves normalized to

Table 2
Residual Signal for
Consecutive Readouts

Readout	Relative intensity (%)		
	GR-200	SSD-UR	SSD-NR
1	100	100	100
2	2.50	2.04	0.38
3	1.40	0.86	0.13
4	0.80	0.40	0.13
5	0.60	0.25	0.04
6	0.40	0.15	-
7	0.35	0.07	-
8	0.27	-	-
9	0.21	-	-
10	0.16	-	-
total			
	6.7	3.8	0.70

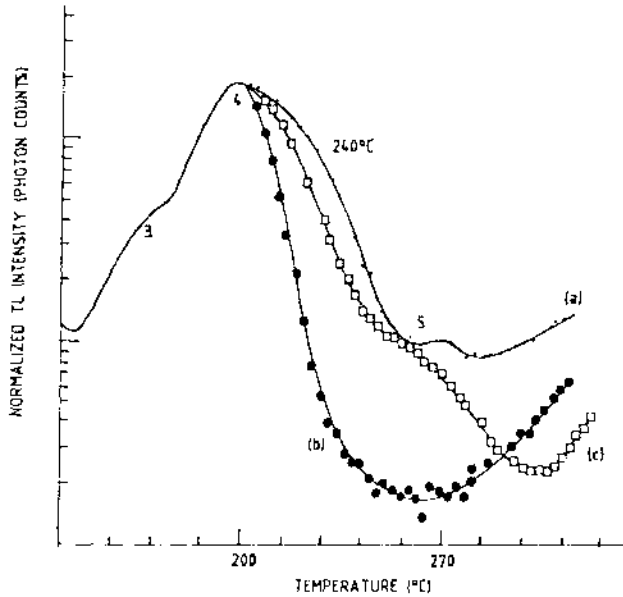

Figure 1: Glow curves of various $LiF:Cu, Mg,P$ materials: (a) GR-200 (25:1, 7-10%); (b) SSD-NR (17:1, 0.7%); (c) SSD-UR (37.7:1, 3.7%) The figures in brackets show the sensitivity relative to TLD-100 and the total relative intensity of the undesirable high temperature structure labelled 5

identical peak 4-heights for two Ben Gurion University preparations and a typical batch of GR-200 for comparison purposes. Note that peak 5 at approximately 270°C can be entirely eliminated and that peak 4 is substantially narrower in the BGU-prepared materials. This suggests that peak 4 itself may be a composite of more than one peak. Reduction of the high temperature TL to negligible levels (<1%) (Fig. 1b) results in a loss in main peak sensitivity of a factor two, but the material is still 15-20 times more sensitive than TLD-100, and the resultant RFOM is 2400. The very high sensitivity material

(Fig. 1c) has a RFOM of 820 and the GR-200 material a RFOM of approximately 300 (Fig. 1a). Finally Table 2 shows the relative intensity of the residual signal following consecutive 240°C for 10 seconds readout in the three materials shown in Figure 1. The material in which peak 5 is eliminated (SSD-NR; Fig. 1b) is virtually free of residual signal.

SUMMARY AND CONCLUSIONS

We have developed a preparation procedure for LiF:Cu,Mg,P which results in a TL phosphor 35±4 times more sensitive than TLD-100. At this level of sensitivity the second-readout-residual is 2-3%. In further investigations we found that, we could produce a material with a sensitivity 17±2 times that of TLD-100, but with a second-readout residual of only 0.25%-0.5%, following 240°C for 10 seconds readout. This negligible residual is achieved via almost total elimination of the high temperature peak and renders the material useable in "unannealed" form. To sum up, astute manipulation of material preparation parameters has led to a LiF:Cu,Mg,P thermoluminescent material 15-20 times more sensitive than TLD-100 and useable in "unannealed" form due to elimination of the high temperature peak. This material, we believe, is the "long-sought-after" ideal "tissue-equivalent" gamma dosimeter which should bring significant advances to environmental and personnel dosimetry.

REFERENCES

1. Horowitz, Y.S., 1990, "New Thermoluminescent Materials", Editorial, Radiat. Prot. Dos., 30, pp. 75-76.
2. Bhatt, B.C., Shinde, S.S. and Bhatt, R.C., 1989 "Comparative dosimetric studies of three LiF TL phosphors", Radiat. Prot. Dos., 27, pp. 21-27.
3. Horowitz, Y.S. and Horowitz, A., 1990, "Characterization of LiF:Cu,Mg,P (GR-200) for personnel thermoluminescence dosimetry", Radiat. Prot. Dos., 32, pp. 279-282.
4. Horowitz, Y.S. and Ben Shachar, B., 1988, "Thermoluminescent LiF:Cu,Mg,P for gamma ray dosimetry in mixed fast neutron-gamma radiation fields", Radiat. Prot. Dos., 23, pp. 401-404.
5. Horowitz, Y.S. and Stern, N., 1990, "Relative thermoluminescent efficiency of LiF:Cu,Mg,P to alpha particles: Theory and Experiment", Radiat. Prot. Dos., 33, pp. 287-290.
6. Jones, A.R., Ohno, A.H. and Richter, W.F., 1989, "A personal dosimeter using LiF(Mg,Cu,P) thermoluminescent material", Radiat. Prot. Dos., 27, pp. 261-266.
7. Horowitz, A. and Horowitz, Y.S., 1990, "Optimization of LiF:Cu,Mg,P for radiation protection dosimetry", Radiat. Prot. Dos., 33, pp. 267-270.

ACKNOWLEDGEMENTS

This research was supported in part by Grant no. 8700101 from the United States - Israel Binational Science Foundation.

THE ACTIVITIES OF THE CANADIAN NATIONAL REFERENCE
CENTRE FOR IN-VIVO MONITORING

Gary H. Kramer

Environmental Radiation Hazards Division, Bureau of
Radiation and Medical Devices, 775 Brookfield Road,
Ottawa, Ontario, K1A 1C1

ABSTRACT

The Human Monitoring Laboratory (HML) has been designated as the Canadian National Calibration Reference Centre for In-Vivo Monitoring. The HML conducts nationwide inter-comparison programs for facilities engaged in whole body counting, thyroid counting and thorax counting. In order to conduct and maintain this program the HML also designs and builds phantoms.

INTRODUCTION

In 1983, the Atomic Energy Control Board (AECB) decided that a formal program of calibration for all forms of dosimetry was required. The AECB is responsible, under the authority of the Atomic Energy Control Act, for the health and safety of workers and the public from potential radiological hazards associated with the operation of nuclear facilities and the use of radioactive materials. The AECB, through its regulations, requires its licensees to determine the radiation dose received by workers and to control such doses below specified limits.

The AECB set up three working groups to determine the requirements for comprehensive calibration programs for external dosimetry, internal dosimetry and dosimetry of radioactive atmospheres. The working group for internal dosimetry recommended that the Bureau of Radiation and Medical Devices (BRMD) administer the calibration reference program for that aspect of dosimetry as a development of its existing informal calibration program.

In 1984, funding was obtained for this development and a reference centre was established at BRMD; part of the Reference Centres is the HML. The HML has now been designated as Canada's National Calibration Reference Centre for In-Vivo Monitoring. The HML is, therefore, a unique facility in North America as it provides an external calibration to a facility to either confirm that their in-house calibration is accurate or provides sufficient information so that the facility can confidently implement a new calibration data set. Currently this service is free of charge.

Since 1987 the HML has been improving and expanding the design of the phantoms used in the inter-comparison; recent advances have been heavily influenced by the recommendations of the Workshop on Standard Phantoms (1).

The use of the BRMD standard phantoms is two-fold. First, facilities can compare their results to other Canadian facilities and judge their performance based on the results. Second, and more importantly, the participation in the HML's Inter-comparison program allows the facility to demonstrate that their in-house calibrations are accurate and that the in-house quality assurance program is performing as expected. The use of an outside independent standard gives any quality assurance program more credibility than it would otherwise have if all quality control results were based on in-house data.

WHOLE-BODY COUNTING FACILITIES

The factors that can introduce uncertainties into the estimate of body activity can come from a variety of sources:

- Heterogeneous distribution of activity within the body that is subsequently evaluated using an efficiency derived from a homogeneous distribution. This uncertainty can often be mitigated if the whole body counter is a scanning type. The scanning type is relatively insensitive to distribution (2).
- Individual being monitored is a different physical size to the reference phantom that was used to calibrate the whole body counter.
- The phantom used to calibrate the whole body counter is not sufficiently anthropomorphic. This will introduce a systematic bias into all of the measurements.

Table 1 HML inventory of BOMAB Phantoms

The HML can provide an *In-Vivo* monitoring facility with a range of phantoms that can partially mitigate the problems outlined above. The present inventory of BOMAB phantoms held by the HML is shown in Table 1. The design, construction and detailed use of the phantoms is described elsewhere (3,4).

<u>Phantom</u>	<u>Size</u>	<u>Number</u>
PM Series	Ref. Male	7
PF Series	Ref. Female	2
P10 Series	Ref. 10 yr old	2
P4 Series	Ref. 4 yr old	2
PM5 Series	5% male	1
PM95 Series	95% male	1
PM _{sec}	Ref. Male	1

The BOMAB phantoms, which are accompanied by HML staff, are used as follows:

- Size dependency measurements
- Unknown radionuclide(s) identification. The unknown radionuclide(s) are not always homogeneously distributed so that the facility must both identify the radionuclide and its location in the phantom.

THORAX COUNTING FACILITIES

Thorax monitoring facilities are usually concerned with lung depositions; however, they can also be used to monitor other organs of the upper body such as the liver, abdominal contents or even the head.

The HML can assist Thorax monitoring facilities by use of the Lawrence Livermore National Laboratory Realistic Torso Phantom that has been recently (1) accepted as the closest approximation to a standard torso phantom until such times as a new model is constructed. The HML holds one LLNL phantom with a large variety of accessory to extend calibrations to different sized individuals.

The HML can also provide other radionuclides that can be inserted in the blank lung sets or other organs in the torso. For example, the HML has manufactured some ^{14}C inserts that can be loaded into the phantom to simulate a lung deposition of insoluble ^{14}C .

The different overlay sets can be combined with the phantom to simulate different chest wall thicknesses and also different chest wall compositions; however, in practise, it is not necessary to vary the chest wall composition if the photon energy exceeds 60 keV. The chest wall composition does not affect the attenuation for photon energies in excess of 60 keV and chest wall thickness is the only concern. The phantom is usually accompanied by HML staff.

THYROID MONITORING FACILITIES

The BRMD neck phantom has been re-designed to remove some of the shortcomings of the other two phantoms (6). This phantom is constructed from a material that is a good tissue substitute for ^{125}I ; the form is anthropomorphic (but no spinal column is included); the thyroid insert closely resembles the thyroid gland (although visually it does not look like a thyroid gland - see reference 5 for a better description); the depth of the thyroid insert can be varied; the size of the thyroid insert can easily be modified to simulate small or large thyroid glands.

The BRMD neck phantom is distributed to thyroid monitoring facilities on request. The phantom is sent with either simulated ^{125}I (^{129}I) or simulated ^{131}I ($^{133}\text{Ba} + ^{137}\text{Cs}$), a blank insert, an overlay plate for multiple depth measurements. The phantom is also sent with a document describing its usage (7) as HML staff do not usually accompany the phantom.

Typically the phantom will have two inserts for each radioiodine. One insert will have an activity in the tens of Becquerels and the other an order of magnitude higher. The users are not informed of these activities until after the inter-comparison is completed.

The phantoms may also be used as calibration standards. The HML sends the phantoms, on request, to facilities that would like to calibrate (or recalibrate) their monitoring equipment.

REFERENCES

1. Gary H. Kramer and Kenneth G.W. Inn. Proceedings of the Workshop on: Standard Phantoms for *In-Vivo* Radioactivity Measurement. Human Monitoring Laboratory Technical Document HMLTD-90-4, 1990.
2. J.R. Johnson. ^{137}Cs and ^{60}Co Recalibration of Urine and Whole Body Counters, and Distribution Study for Whole Body Counter. Medical Research Branch Technical Document MR-76-3, Chalk River Nuclear Laboratories, 1976.
3. Gary H. Kramer, Linda C. Burns and Léo Noël. Construction and Characterisation of the Elliptical (BOMAB) Phantoms. Human Monitoring Laboratory Technical Document HMLTD-90-1, 1990.
4. Gary H. Kramer. Usage of the Elliptical (BOMAB) Phantoms. Human Monitoring Laboratory Technical Document HMLTD-91-4, 1990.
5. Gary H. Kramer. The LLNL Torso Phantom: A Description of Usage. Human Monitoring Laboratory Technical Document HMLTD-90-3, 1990.
6. Gary H. Kramer, Kase Gamarnik, Léo Noël and Linda C. Burns. Fabrication of the Thyroid and Neck Phantoms. Human Monitoring Laboratory Technical Document HMLTD-90-6, 1990.
7. Gary H. Kramer, Daniel Agterberg and Léo Noël. Thyroid Counter Recalibration using the BRMD Neck Phantom. Human Monitoring Laboratory Technical Document HMLTD-88-3, 1988.

RADIOACTIVE LEVELS AND DOSES OF ^3H AND ^{14}C IN WHITE SPIRITS

DENG GUOLUN

Sichuan Institute of Radiohygiene Protection, Chengdu, China

White (and yeast) spirits is a general name for strong alcoholic beverages in China. The paper reports levels and doses of ^3H and ^{14}C in 65 spirits samples between 1986 and 1987. Experiments were made by measuring and analyzing each sample, using a low background liquid scintillation spectrometer.

Radioactive levels of 65 spirits samples are as follows:

Variant range of ^3H activity is $98.2 - 170.6\text{Bq}\cdot\text{dm}^{-3}$ and its average is $149.2 \pm 17.3\text{Bq}\cdot\text{dm}^{-3}$; Variant range of ^{14}C activity is $38.8-80.2\text{Bq}\cdot\text{dm}^{-3}$ and its average is $57.4 \pm 8.2\text{Bq}\cdot\text{dm}^{-3}$.

If the man drinks 200cm^3 of spirits daily, the annual dose equivalents will be $0.19\mu\text{Sv}$ of ^3H and $2.5\mu\text{Sv}$ of ^{14}C .

In ordinary strong alcoholic beverages that contain 57-60% alcohol, the mean ^3H and ^{14}C activities are $153.8\text{Bq}\cdot\text{dm}^{-3}$ and $60.3\text{Bq}\cdot\text{dm}^{-3}$, respectively, but in spirits of lower alcoholic content (38-40%), the mean ^3H activity is $114.6\text{Bq}\cdot\text{dm}^{-3}$, that is 25.5% less than ordinary spirits, and the mean ^{14}C activity is $46.1\text{Bq}\cdot\text{dm}^{-3}$, that is 23.5% less than ordinary spirits.

We compared the ^3H and ^{14}C contents of five kinds of staple grains from both Sichuan and Guangdong provinces. We learned that the level of ^3H activity in spirits is ten times higher than in grains and water, and the level of ^{14}C activity in spirits is equivalent to that in grains. White spirits has fully concentrated ^3H and ^{14}C from both grain and water, and activities increase with increasing alcoholic content. ^3H in spirits probably is averaged from both water and grain, and ^{14}C is averaged mostly from grain.

DOSIMETRY FOLLOWING INTERNAL CONTAMINATION:
COMPARISON OF SOME BIOASSAY MODELS

A.S. Keverling Buisman* and A. Badreddine#
*Netherlands Energy Research Foundation (ECN)
P.O.Box 1, 1755 ZG Petten, The Netherlands
#Centre de Radioprotection et de Sûreté
B.P. 1017, 16000 Alger, Algeria

ABSTRACT

A Task Group of the ICRP is currently reviewing the model to be used for the respiratory tract. The choice of the model will not only change the dosimetry, but will also have consequences for the whole body burden as a function of time following an internal contamination. Therefore the data for the evaluation of the intake derived from the measurement of the body burdens must be recalculated, to be included in the new release of our compilation. Examples of the results of two models are given for the inhalation of ^{60}Co and compared to the current model and to measured data.

INTRODUCTION

An earlier compilation of data [1] provides predicted whole body retention functions for over 400 radionuclides, based on the models given in ICRP-30 [2]. Due to the development of a revised respiratory tract model by the ICRP, all inhalation data are now being recalculated. We also use this opportunity to include excretion functions in the new release of the report. The models we have used include the proposed ICRP-model [3] and the more simple version as given by Johnson and Milencoff [4]. The proposed ICRP-model involves 14 compartments, each with one or more subcompartments. All transfer rates are constant. The second model employs only three compartments, but the transfer rates are time dependent. Both models use mechanical transport of particles, independent of solubility. We compare the results of both models to the current version of the lung model.

MATHEMATICAL TREATMENT

The preliminary ICRP-model is incorporated in a PC-based programme, the Lung Dose Evaluation Programme, LUDEP [5].

We have used this code to calculate the whole body burden (fraction of intake as a function of time) for ^{60}Co . In the calculation default values are used for all parameters, i.e. a 1 μm AMAD aerosol is inhaled by a nose breathing lightly working adult male. The total deposition for this case is 45.6% of the intake: 28.5% in Extra-Thoracic, 5.6% in Bronchial and 11.5% in Alveolar/Interstitial.

The same default values are used for the three compartment model. However, here the deposition amounts to only 28%. This may be compared to the currently used value of 63%.

The three compartments (Extra-Thoracic, Slow-clearing and Fast-clearing Thoracic) are cleared mechanically to the GI-tract, described by three time dependent functions $G(t)$. The solubilisation is given by a function $B(t)$. After solving the set of coupled differential equations numerically (one for each compartment), all activities are added to obtain the whole body burden. The calculations are performed on a Tulip¹ personal computer. The programming language is Turbo Pascal² with its numerical toolbox. The whole body burden from the current ICRP-model is taken from our earlier compilation [1], based in ICRP-30.

¹ Tulip is a registered trade mark of Tulip Computers,
's Hertogenbosch, The Netherlands.

² Turbo Pascal is a registered trade mark of Borland International,
Inc., Scotts Valley, CA, USA.

RESULTS FOR ^{60}Co

As an example we have recalculated the body burden for inhalation of ^{60}Co , both for Class Y and W (called S and M in the new model). The results are given in Figures 1 and 2.

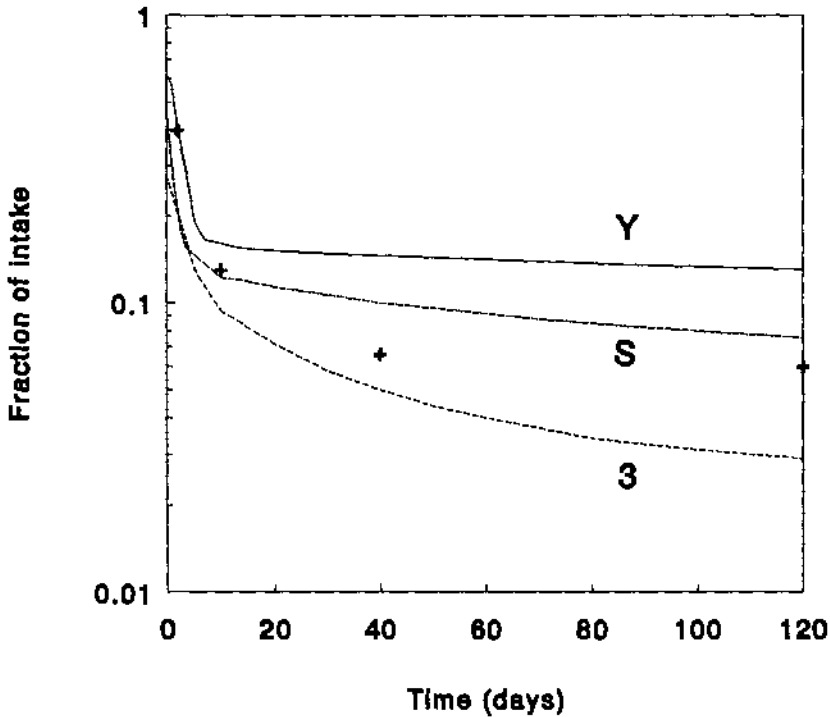

Figure 1 Calculated body burden after inhalation of ^{60}Co . + = example of actual measured data.

- Y = Class Y current ICRP-model
- S = Type S proposed ICRP-model
- 3 = Class Y 3-compartment-model

It is clear from this information that the main difference stems from the lower deposition values. In Figure 1 we have tentatively included the relative whole body burden measured for an actual inhalation case. There seems to be no real favorite among the models, but the new models predict the long term retention better in relation to the original deposition. This is probably the result of the inclusion of the fast mechanical clearing of the ET-compartment.

The more detailed nature of the proposed ICRP-model, however, makes a more precise calculation of the dose to different parts of the respiratory tract possible.

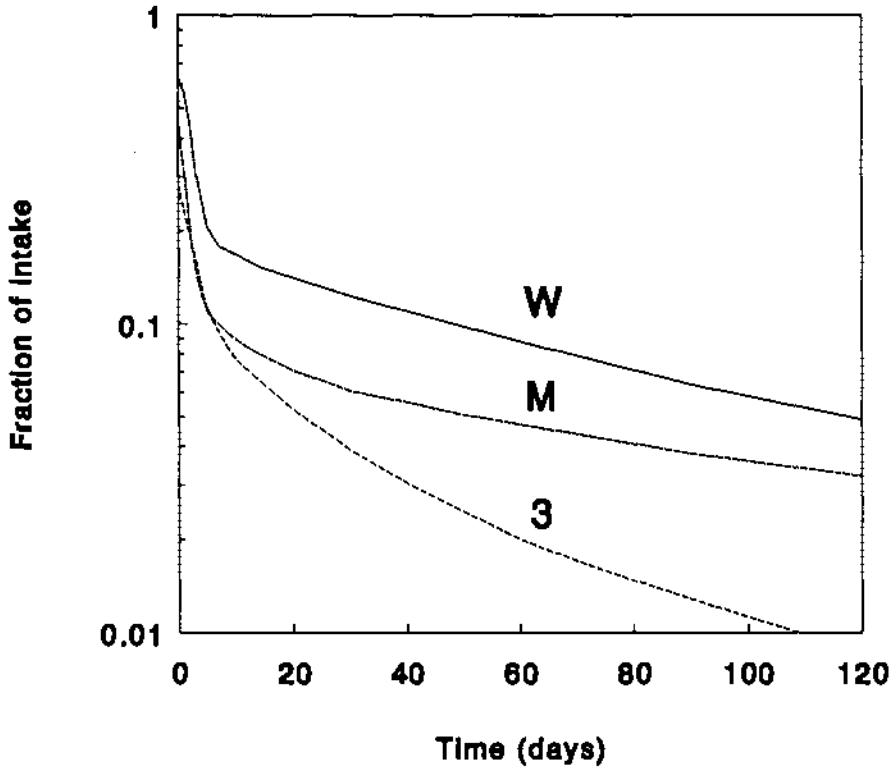

Figure 2 Calculated body burden for inhalation of ^{60}Co .

W = Class W current ICRP-model
M = Type M proposed ICRP-model
3 = Class W 3-compartment-model

The three compartment model predicts a faster clearance in both cases.

REFERENCES

- {1} A.S. Keverling Buisman, ECN-report 116/125 (1982)
- {2} Ann. ICRP 2 3/4(1979), 4 3/4 (1980), 6 2/3 (1981)
- {3} W.J. Bair, Rad. Prot. Dosim., in press (1991)
- {4} J.R. Johnson and S. Milencoff, HP 57 Supp 1 (1989)
- {5} A. Birchall et al., Rad. Prot. Dosim., in print

WHOLE-BODY MONITORING OF A LARGE POPULATION SAMPLE

M.P. Hayball, K.D. Lyttle, P.P. Dendy and K.E. Goldstone

Departments of Medical Physics and Nuclear Medicine
and East Anglian Regional Radiation Protection
Service, Addenbrooke's Hospital, Cambridge, U.K.

ABSTRACT

The results of a survey in which 1220 volunteers were monitored using the Addenbrooke's whole-body counter during the period April 1988 - March 1991 are presented. The decline in radiocaesium post Chernobyl was registered and special techniques of spectral analysis and data averaging were used to establish a maximum likely average radiocaesium body burden in the adult population. Other man-made radionuclides (eg. ^{99m}Tc , ^{131}I) were occasionally detected and the likely origins investigated. The presence of radon decay products in variable amounts influences the minimum detection level of other radionuclides and some consequences of this interference are discussed.

INTRODUCTION

One of the recommendations of the Black report (1) investigating the possible increased incidence of leukaemia near to a nuclear fuel reprocessing plant in the North West of England was that there should be more research using whole-body monitors into levels of radioactivity occurring in the general population. Cambridgeshire was selected as a suitable location to obtain baseline data on a large number of volunteers because it has a low level of environmental radioactivity.

In addition to ^{137}Cs and ^{134}Cs from Chernobyl, we were interested in measuring ^{99m}Tc and ^{131}I since, along with tritium (not detectable in a whole-body counter), they account for over 90% of all radioactive discharges in the locality (2).

THE POPULATION SAMPLE

1220 volunteers were each monitored for 1000 s in the whole-body counter. For statistical analysis of the local population, only persons who had lived in Cambridgeshire for more than three years and had not been knowingly exposed to radionuclides were included. This reduced the total number to 1032, 314 adult males, 521 adult females, 68 male children and 129 female children. Combining the children together into one group provides a total of about 200 which is probably larger than any single group of children monitored previously.

RESULTS AND DISCUSSION

1) Radiocaesium from Chernobyl

The average Cs: ^{40}K ratios each month for all adult males throughout the study are shown in Figure 1. During the period April 1988 - July 1989 this ratio was 2.34%. The ratio was 2.06%

for adult females but the lowest recorded ratio was for male children (1.47%); just significantly lower than that for female children (1.90%).

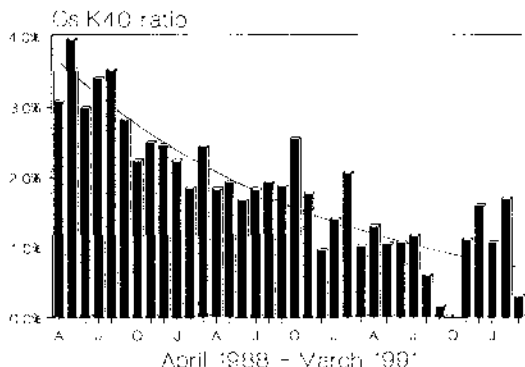

Figure 1. Monthly average contamination of adult male volunteers expressed as a ratio of radiocaesium to ^{40}K .

Although radiocaesium was readily detectable in all volunteers at the start of the study, by August 1989 results suggested that there was no definite evidence of caesium in some of the spectra and during the final twelve months from April 1990 there was no discernible trend in caesium levels (Fig. 1). Using a suitable model of exponential decay based on our own data, the average estimated effective dose per person to the population of Cambridgeshire from caesium radionuclides released from Chernobyl during the period April 1988 to March 1991 was 8.4×10^{-6} Sv for men, and 5.7×10^{-6} Sv for women.

For a single 1000 s measurement using the Addenbrooke's whole-body counter estimates of the minimum detectable amounts (MDA) of activity for ^{137}Cs and ^{134}Cs are 60 Bq and 30 Bq respectively. The major limitation is statistical, thus for large numbers of volunteers an averaging process may be used to obtain a more accurate figure for the population as a whole.

The spectra obtained since April 1990 have been summed for the four groups of volunteers. Unfortunately, analysis of the 662 keV peak from ^{137}Cs is confounded by a variable and unknown contribution from ^{214}Bi , a radon daughter, which emits 610 keV gamma rays. If we assume that all counts detected were due to caesium then the maximum remaining average level of caesium was 10 Bq for adult males and females. For the group of adult males the energy of the detected peak was half way between the peaks of ^{214}Bi and ^{137}Cs . This suggests that the average level of caesium activity remaining is probably about 5 Bq for adult males. For the group of female adults the peak detected was at 614 keV which suggests that most of the activity present was due to radon. For the male and female children, no peak could be detected in the summed spectrum during this phase of the study, so activity levels are even lower.

2) Other Man-made Radionuclides

In this category we have included manufactured articles containing radium. Fourteen volunteers had measurable activity either in or on their person and these are summarised in Table 1. On each occasion an explanation for the observed activity could be readily determined and the levels of activity were extremely small. Release of ^{99m}Tc and ^{131}I result from their widespread use in medicine for diagnosis and therapy respectively. It is notable that in 9 of the 14 cases where radioactivity was detectable, one of these two radionuclides was involved.

The benefit of adding spectra from different volunteers was again illustrated by looking for the 364 keV peak of ^{131}I in the summed spectra for 22 adult male volunteers who were all measured after the caesium activity from Chernobyl had become undetectable. The limit on detection is again set by radon decay products - the 350 keV peak from ^{214}Pb in this case. Radon decay products were known to be present in the summed spectrum because other peaks (eg. 610 keV from ^{214}Bi) were detected. Nevertheless, the minimum level of detectability for ^{131}I was reduced to 30 Bq from 60 Bq for a single 1000 s measurement.

Table 1. Man-made radionuclides detected in or on volunteers.

Nuclide	Number of cases	Estimated Activity (Bq)	Reason for Contamination
^{99m}Tc	6	<1000	subjects had been in Nuclear Medicine waiting room prior to monitoring.
^{22}Na	1	1000	accidental spillage during Nuclear Medicine test.
^{226}Ra	1	200	luminous watch after removal.
^{86}Rb	2	2000 600	used in studies at Medical Research Council laboratory on site.
^{232}Th	1	100	a physics teacher, Thorium was used at school. (could have been natural, poor statistics)
^{131}I	3	1000 200 100	all visitors to patients on radionuclide therapy ward.

When spectra for volunteers in all four groups were combined, the average activity in the energy window corresponding to ^{131}I was 10 Bq per person. However the energy of the peak suggests that most, if not all, of the peak was due to ^{214}Pb . We conclude that the only real evidence for ^{131}I activity in this sample of volunteers resulted from close contact with patients being treated with this radionuclide for therapeutic purposes.

3) Radon

The whole-body monitor has a very low radon level, so we were able to look for radon daughters in volunteers. Approximately 15 persons had unusually high levels of radon

daughters compared with the rest of Cambridgeshire volunteers. Rather more showed probable activity. There is no reasonably practical method of calibrating the whole-body counter for quantification of radon daughters (^{214}Pb and ^{214}Bi) but the activities seem to be in the range 200 - 1000 Bq. In some cases these can be traced to contact with a radon source such as an old luminous watch but other cases can only be explained by the presence of increased radon levels at home.

Measurement of radon contamination from the radon daughter gamma emission is difficult. Volunteers are measured fully clothed and radon daughters can be deposited onto dust from atmospheric radon thereby contaminating clothing and adding to the activity measured from internal radon. The biological half-life of inhaled radon is not known but is likely to be of the order of a few hours or less although the daughters are likely to remain in the body for longer. Hence, the ratio of radon daughters to radon is uncertain and the levels of radon daughters will depend on how recently the volunteer was exposed to radon.

CONCLUSION

Overall the project has achieved the primary objective, which was to establish a substantial database for a large group of volunteers from the same part of the U.K. The Chernobyl accident provided a fortuitous opportunity to validate the methodology on human volunteers rather than phantoms and the study continued for long enough to establish baseline data in the post-Chernobyl era. These data should prove valuable in helping to monitor the future effects on the population of the release of man-made radionuclides into the environment.

REFERENCES

1. HMSO. Investigation of the possible increased incidence of cancer in West Cumbria. London. 1984.
2. East, B.W. Environmental behaviour of radionuclides in an urban environment. Department of the Environment Report No: DOE/HM1P/RR/91/026. 1991.

ACKNOWLEDGEMENTS

These results have been obtained in the course of a study commissioned by the Department of the Environment in the United Kingdom. Additional funding has been provided by the Cambridgeshire County and District Councils.

BIOLOGICALLY-EQUIVALENT DOSIMETRY FROM
NITROGEN-14 NUCLEAR QUADRUPOLE RESONANCE

D.E. Hintenlang, L.H. Iselin and K. Jamil

Department of Nuclear Engineering Sciences
University of Florida
Gainesville, FL 32611-2055 USA

ABSTRACT

A new method for measuring the damage to biological systems from ionizing radiation has been developed based upon the principles of ^{14}N Nuclear Quadrupole Resonance (NQR). NQR studies have been performed on several biologically-equivalent materials. Variations of NQR parameters are presented for materials exposed in gamma and neutron fields. The radiation induced structural changes are modeled and quantitatively correlated with photon and neutron fluxes and absorbed dose rates. Radiation induced changes in the NQR spectra provide a sensitive measure of potential biological damage.

INTRODUCTION

The NQR technique provides a sensitive probe of electron bonding configurations around the nitrogen sites for a number of organic, biologically-significant compounds. Detailed information on radiation effects is obtained by monitoring the interaction between the electric field gradient produced by the electron bonding configuration and the nuclear quadrupole moment of the probe nucleus. Studies have been performed on the simplest compounds of the urea family, urea and thiourea. By utilizing biological materials as dosimeter material, and monitoring the radiation induced changes, a representation of potential biological damage is obtained.

THEORY AND EXPERIMENT

The bonding configuration around ^{14}N nuclei produces an electric field gradient (EFG) at the nuclear site which causes splitting of the nuclear energy levels due to an interaction with the nuclear electric quadrupole moment (eQ). Observable transition frequencies between the energy levels are

$$\nu_+ = \frac{(3+\eta)e^2qQ}{4h} \quad \nu_- = \frac{(3-\eta)e^2qQ}{4h}$$

where η is the asymmetry parameter measuring deviation from axial symmetry, eq is the EFG component with maximum amplitude, and h is Planck's constant. These transitions are forced by the application of radiofrequency (RF) energy at the appropriate transition frequency. Single pulses of $14\mu\text{s}$ duration were used to excite the spin system at 77 K and the resulting free induction decays (FID's) were characterized to determine the radiation response of the material. All resonance frequencies for urea and thiourea were observed to occur at previously

reported frequencies between 2 and 3 MHz, using pulsed NQR techniques with a pulsed spectrometer commercially available.¹

RESULTS AND DISCUSSION

The initial radiation response of urea and thiourea has been characterized using gamma and neutron radiation fields. Gamma irradiations were performed with a ⁶⁰Co irradiator² providing a delivered dose rate of 0.122 Gy s⁻¹. The response of the NQR parameters of urea have been investigated with the urea in two physical forms. Dry polycrystalline urea does not exhibit any detectable change in its NQR

parameters for delivered doses of ⁶⁰Co radiation up to 2000 Gy. Hydrated polycrystalline urea exhibits pronounced changes in several NQR parameters when exposed to ⁶⁰Co radiation. The most pronounced effects are manifest as a decrease in the spin-spin relaxation time, T_2 , as the delivered dose increases, figure 1. These changes may be related to small changes in the chemical bonding configuration of the urea, and not large-scale structural rearrangement³. Urea studies demonstrate that the response of these materials may be greatly enhanced when water is incorporated into the polycrystalline matrix. A comparison of the response of the dry and hydrated urea samples demonstrates that radiolytic products created in the water subsequently attack urea molecules. This is the dominant mechanism for radiation effects, not direct interactions with urea molecules.

Thiourea has a molecular structure similar to that of urea, with the oxygen atom in urea being replaced by a sulfur atom to form thiourea. The NQR and radiation responses of these two materials would be expected to be quite similar. The incorporation of sulfur instead of oxygen, however, causes the two nitrogen sites in the molecule to become nonequivalent, and the sites experience different EFG's and resonate at slightly

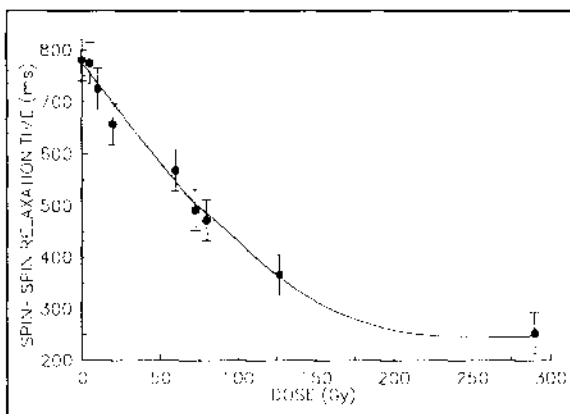

Figure 1 Urea T_2 response to gamma irradiation

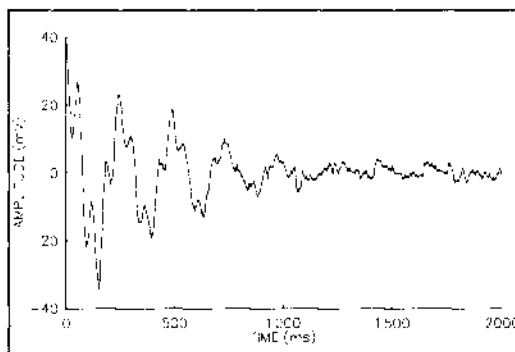

Figure 2 FID of thiourea

different frequencies. The thiourea FID is therefore complicated by the superposition of two FID's from independent nitrogen sites, and exhibits a more complex shape, figure 2. This requires that sophisticated data analysis methods be utilized. In this case a non-linear curve fitting program was developed and used to separate the T_2 's associated with each of the two components of the FID.

Studies analogous to those performed on urea were attempted on thiourea. Although dry polycrystalline samples were irradiated to much higher doses than the urea, no radiation induced changes were observed. Hydrated polycrystalline samples of thiourea cannot be studied because water reacts with the thiourea molecules and eliminates any NQR response. Dry polycrystalline thiourea was characterized for changes induced by exposure to neutron radiation. The samples were irradiated in the central beam port of the University of Florida Training Reactor with a fission neutron spectrum of flux $1.2 \times 10^{16} m^{-2} s^{-1}$.

Neutron irradiation resulted in a dramatic decrease in NQR signal intensity as illustrated in figure 3. A much greater fraction of ^{14}N nuclei are prevented from contributing to the NQR signal than would be expected from calculations of the number of thiourea molecules damaged by the delivered neutron fluences. This indicates that the NQR parameters are sensitive enough to be affected by radiation induced changes at least several molecules away.

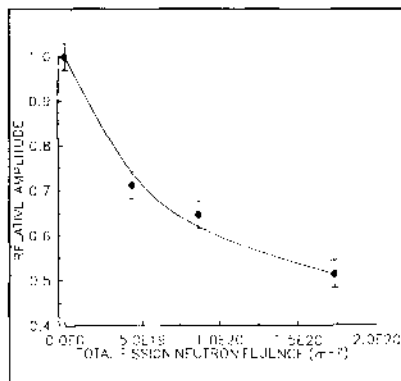

Figure 3 Thiourea response to fission neutrons.

More complex molecules, such as guanidine sulfate, are expected to provide more sensitive probes of radiation induced changes using NQR techniques. Due to the superposition of several nitrogen sites, however, the quantization of contributions from each site requires more sophisticated data analysis methods. Traditionally, data analysis for magnetic resonance spectra has been done by discrete Fourier Transform (FT) of the time series data via the Cooley-Tukey Fast Fourier Transform algorithm.⁴ The FT power spectrum in frequency space is used to isolate the appropriate resonance frequencies and the FT absorption spectrum yields the spin relaxation times which are proportional to the inverse of the line widths. In pulsed NQR the loss of frequency-dependent phase information due to the spectrometry electronics results in a mixing of absorption and dispersion modes in the cosine portion of the FT. We have been unable to characterize the missing phase information and thus the individual line widths cannot be determined by this method.

The Marquardt method⁵ of non-linear least squares curvefitting was used to overcome this problem. The experimental FID is fit to a Lorentzian line in the time domain:

$$v(t) = \sum_{i=1}^N a_i \cos(\omega_i t + \phi_i) e^{-t/T_{2i}}$$

with $v(t)$ being the composite time domain signal, N the number of different ^{14}N sites, a_i the signal amplitude, ω_i the difference frequency between the applied RF and the resonance frequency, and ϕ_i the phase shift. A data reduction method recently applied to magnetic resonance spectra, HSVSD⁶, which converts the non-linear problem of exponentially damped sinusoids in the time domain into a linear problem in state space and solves by linear least squares, will be used in future work on more complex molecules.

CONCLUSIONS

This work represents the first observed detection of gamma and neutron radiation effects in bio-molecules using ^{14}N NQR. Neutron radiation is capable of producing direct effects in the compounds studied, while gamma radiation effects on the molecular structure occurred as a result of indirect interaction with radiolytic products formed in hydrated samples. While the system has yet to be optimized to maximize the response to ionizing radiations, more sophisticated data analysis methods are being developed to improve the detection limit of this dosimetry technique. Ultimately ^{14}N NQR is expected to provide a sensitive method for radiation dosimetry and the study of the response of fundamental biological systems to ionizing radiation.

ACKNOWLEDGEMENTS

Work supported by U.S. Department of Energy Office of Energy Research under contract DE-FG07-89ER12890. Mr. Iselin's research performed under appointment to the Nuclear Engineering and Health Physics Fellowship program administered by Oak Ridge Associated Universities for the U.S. Department of Energy.

REFERENCES

1. Ritec, Inc. Warwick, RI 02886 USA.
2. Hanrahan, R. J. Int. J. Appl. Radiat. Isot. 13:254-255; 1962.
3. Hintenlang, D.E. and G.A. Higgins. submitted to Nucl. Sci. Eng.
4. Press, W.H., et al. Numerical Recipes, New York: Cambridge University Press; 1989: 390-395.
5. Marquardt, D.W. J. Soc. Ind. Appl. Math. 11:431-441; 1963.
6. Barkhuijsen, H. et al. J. Mag. Res. 73:553-557; 1987.

IS TRACK-ETCH DOSIMETRY READY FOR NEUTRON PERSONAL
DOSIMETRY AT HIGH ENERGY ACCELERATORS?

N. Anthony Greenhouse
Bldg. 75, Rm.112
University of California
Lawrence Berkeley Laboratory

26 February 1991

Experiments in high energy particle physics began with Ernest O. Lawrence's cyclotrons at the University of California, Berkeley. The original and still current favorite personal monitor for neutrons is a Kodak photographic emulsion (Type A, or "NTA film"). Research at LBL and other accelerator laboratories suggests that electrochemically etched CR-39 plastic detectors have sufficient spectral response and sensitivity to replace NTA film as a personal neutron dosimeter. The primary advantages to CR-39 are its lack of photon response and minimal loss of latent track images.

We have compared responses of CR-39, NTA film, and bubble detectors in neutron fields where the spectra and dose equivalent rates were determined by Bonner spheres and NE-213 spectrometry techniques. Experiments at the Bevalac and the 88-Inch Cyclotron provided data which support the hypothesis about the appropriateness of CR-39. Other measurements also verified the "blind region" between ~ 6 and ~ 12 MeV. However, most of the dose equivalent is delivered by neutrons in excess of 10 MeV. Spectrometry at the Bevalac suggests that about 80% of Hn meets this limitation. It appears that (n,alpha) reactions and recoiling carbon and nitrogen nuclei cause the high energy response in CR-39.

This work was supported by the U.S. Department of Energy under Contract DE-ACC3-76SF00098.

INFORMING AND EDUCATING THE PUBLIC ON
RADIATION RISKS

F. LUYKX

Commission of the European Communities,
Luxembourg

ABSTRACT

Over the last decade, and especially since the Chernobyl accident, the need for informing and educating the public on radiation risks has been widely recognised by decision-makers around the world. In principle at least part of this task can be fulfilled by radiation protection professionals in that they know the subject and can, therefore, give correct and objective information and advice. However, since they generally lack experience of communicating with the public, suitable training programmes will be necessary. Such training should cover not just direct communication but should emphasize communication with information intermediaries, such as the media, the medical professions, the decision-makers and the educators. IRPA as a professional organisation should envisage taking up such training programmes in its future activities.

INTRODUCTION

The interest of competent authorities, politicians, nuclear utilities and radiation protection professionals in public information and education has strongly increased over the last decade in recognition of growing public concern for the environment in general and radiation protection aspects in particular. The problems of dispassionate communication with the public after the Chernobyl accident gave added impetus to this trend.

Whereas previous activity in this field was largely confined to the nuclear energy lobby, seeking to underline the advantages of nuclear power and to anti-nuclear organisations, promoting doomsday images of radiation risks, international, national and local authorities are now taking initiatives to improve communications, often with limited success. Initial efforts largely focussed on major nuclear accident risks, but there is now a burgeoning interest in the longterm consequences of low level exposure.

Public opinion surveys in Europe from 1988 to 1991 indicate widespread dissatisfaction with available information (1). The major criticisms are that such information is inadequate, unclear and unreliable but also refer to poor and slow distribution. The credibility of

the various information sources, is highest for (independent) scientists and medical practitioners, and lowest for government and government bodies; in addition to clarity, "good" information requires the authority of scientific knowledge coupled with independence from vested economic industrial and political influence.

INFORMATION INTERMEDIARIES

The normal public information channels are via intermediaries, the most important being:

- the media,
- the medical profession,
- the decision-makers, politicians and trade-union leaders.
- the educators,

Each of these tend to reach particular sectors of the general public and with different objectives.

The media play the most direct role in informing the public about risks from ionizing radiation. It is often said that, if the layman is not well informed, it is the fault of the media. They are criticized for being selective, tending to exaggerate controversy and uncertainty (2), introducing inaccuracies and omitting significant information.

It should, be borne in mind, however, that journalists operate under considerable constraints such as deadlines, editorial pressure, simplicity of presentation, currency of information and limited technical knowledge (3). The last point is particularly important; journalists cannot be expected to appreciate all aspects relevant to judging a situation. As Maclachlan has said (3), "The journalists' best allies in this regard are good common sense and trustworthy sources". Here, professionals in radiation protection can help by giving simple, correct but clear information on radiation risks.

The medical profession, including doctors, pharmacists and nurses, is for many a confidant for all problems related directly or indirectly to health. Training and education of this group on radiation risks, and especially on the possible radiological consequences of nuclear accidents, is, therefore, of extreme importance to public comprehension and averting mistaken, overhasty conclusions on health effects, as was the case on several occasions after the T.M.I. and Chernobyl accidents.

The decision-makers and politicians have the last word in deciding policies related to ionizing radiation but the trade-unions can considerably influence the formulation and execution of such policies.

After the Chernobyl accident we saw several instances of the scientific reality having little influence on political decisions taken to protect the public. One reason for this may be political opportunism but another, no less important, is ignorance. As in the case of the media, the decision-makers and trade-union leaders cannot have specialist knowledge of all fields; they need have trustworthy advisers.

However, the educators, especially teachers in primary and secondary schools, are probably in the longer term the most important group of intermediaries. They are in direct contact with the younger generation, many of whom will continue to draw on what they were taught long after they have left school and perhaps themselves become members of an intermediary group. However, since most teachers are strong defenders of environmental protection, which is appreciated by everybody, they are often anti-nuclear and, due at least partly to gaps in their own knowledge, may consider radioactivity as one of the biggest dangers.

As a result pupils are misinformed from the outset and it will be extremely difficult to change their attitude in later life. Education of the educators must be a first priority.

Within the European Community a programme has been started recently to have environmental studies included in all primary and secondary school curricula by the year 2000 at the latest and listed as a formal examination option as soon as possible after that date (4). Teacher training programmes are being initiated and pilot radiation protection training manuals for teachers in primary and secondary education have already been produced (5).

RADIATION PROTECTION PROFESSIONALS AND PUBLIC INFORMATION

The general public's attitude towards radiation risks depends more on the credibility of the speaker than on the information given. Since practically all opinion surveys show an appreciable public faith in scientists because they know the subject and therefore can give correct and objective information (provided they are seen as independent), radiation protection professionals should consider assistance in informing and educating the public as part of their vocation.

Unfortunately a reproach, often encountered and too often well founded, is that the experts use language unintelligible to the layman. In a talk at a NEA workshop in 1987 (6) Dr. Wilkie, presenting the journalist's view, said about professionals: "... if a journalist telephones them, then they are nervous, hesitant to talk; they answer the questions precisely with myriad qualifications (which never realistically have a hope of getting printed)".

Thus, what the radiation protection professionals really need is training in public communication techniques since most have no experience in this field. Since most health physicists will rarely have direct contact with the public at large the first task will be training on how to inform and educate the intermediary groups. Moreover, since the objectives and backgrounds of these groups differ, it is clear that each has to be treated separately, although the final aim will be the same, i.e. to allow the development within the public of a well informed and realistic attitude towards radiation which should be recognized as no more than a feature of everyday life. More initiative is needed in this field.

CONCLUSIONS

All those having social and political responsibilities are convinced of the necessity of informing and educating the public on radiation risks. This task can, at least partly, be fulfilled by the radiation protection professionals, particularly in support of identifiable intermediary groups. But, since communicating with the public is an art in itself, it should not be undertaken without prior training. IRPA, as a professional organisation, should envisage initiating such training programmes in its future activities.

REFERENCES

1. Eurobaromètre 35, Opinion publique des Européens concernant la radioprotection en 1991, prepared by INRA (Europe) for the CEC, June 1990.
2. Covello V.T., Informing people about radiation risks: a review of obstacles to public understanding and effective risk communication, NEA Workshop on Public Understanding of Radiation Protection Concepts, Paris 1987.
3. MacLachlan A., Meeting of the Belgium Nuclear Society and the Société Française de l'Energie Nucléaire, Brussels May 1991.
4. E.C. Council of Ministers, Resolution of May 1988.
5. C.E.C., Radiation and Radiation Protection, a training manuel for teachers in primary and secondary education, prepared by J.G.H. Draijer and J.R.A. Lakey, Luxembourg 1991.
6. Wilkie T., Why telephone numbers ae the only facts worth knowing about radiation protection, NEA Workshop, Paris 1987.

ACKNOWLEDGMENTS

The author wishes to thank his colleague, G. Fraser, for his assistance and helpful comments.

Media and Political Implications
on Radiation Policy in the United States

Lynne A. Fairbent
Scientific Advisor to
Assistant Secretary for Environment, Safety and Health
U.S. Department of Energy

It was becoming more and more difficult to set regulations based solely on scientific facts in the United States. Recently, the influence of the media and political processes has resulted in efforts to establish prescriptive legislation without regard to science. One such example is the issue of "below regulatory concern" (BRC). In the U.S., BRC is used to define a level of radioactivity that need to be regulated simply because the material is radioactive. The regulatory and technical issues of BRC are not at issue although there is debate within the U.S. scientific community on a single numerical value to be applied in all circumstances. However, the public and political issues related to BRC are perhaps the most difficult ones to address.

This paper reviews the difficulty in conveying to the non-scientific community the rationale for "de-regulating" radioactive material through a review of the BRC process.

MEDICAL X-RAY EXPOSURES IN THE UK

G A M Webb and B F Wall

National Radiological Protection Board,
Chilton, Didcot, Oxon, OX11 0RQ, UK.

ABSTRACT

Recent studies in the UK show that substantial savings could be made in the collective radiation dose to the population from medical x-rays without detriment to patient care. One significant area of potential dose reduction is to reduce the very wide ranges in the doses delivered to different patients for nominally the same diagnostic procedure. National protocols for measuring patient doses and comparing them with guideline reference doses for common x-ray examinations are described. They will help to identify those operating at the top end of these ranges and encourage them to reduce their doses towards the norm.

POTENTIAL FOR PATIENT DOSE REDUCTION

According to figures published by UNSCEAR (1), the UK carries out only about one half of the number of medical x-ray examinations per head of population than the average figure for all other developed countries for which recent data are available. In spite of this, a document published last year by the Royal College of Radiologists and the National Radiological Protection Board (2) on the extent of unjustified and non-optimised x-ray examinations in the UK, indicates that a reduction of nearly one half in the collective dose to the population from medical x-rays might be possible without detriment to patient care.

Clinically unjustified x-ray examinations have been addressed by the Royal College of Radiologists in a booklet providing guidelines for doctors on referral criteria (3). It identifies the uninformed or uncritical use of x-ray examinations in screening tests or as part of routine practice as the greatest source of unnecessary referrals. Indeed, representatives of the College felt that it would not be unreasonable to suggest that at least 20% of x-ray examinations carried out in the UK are clinically unhelpful in the sense that the probability of obtaining information useful for patient management is extremely low (2).

Once medical exposures have been correctly justified, the optimisation of patient protection, i.e. ensuring that radiation exposures are kept as low as reasonably achievable (ALARA) consistent with obtaining the desired diagnostic result, provides another fruitful area for beneficial dose reduction. Exposures can be kept ALARA by critical examination of both examination procedures and imaging equipment. To assess the potential for such dose reduction both locally and nationally requires measurement of the doses typically delivered by each x-ray facility and their national variation. Suitable measurements and control procedures are being encouraged in the UK by the development and publication of a nationally agreed protocol.

NATIONAL PROTOCOL FOR MONITORING PATIENT DOSE

A National Protocol for Patient Dose Measurements in Diagnostic Radiology (4) has been developed by representatives of NRPB, the Institute of Physical Sciences in Medicine

(IPSM) and the College of Radiographers and will soon be published. The most important features are described below.

1 Quantities to be measured

The recommended dose quantities have been selected to meet the following objectives:-

- (a) To be capable of unambiguous definition so that everyone can clearly understand exactly what is to be measured.
- (b) To be capable of simple direct measurement with readily available dosimeters of sufficient precision and accuracy. Valid comparisons can then be made with previous measurements at the same facility, with measurements in other facilities and with national norms.
- (c) To provide a measurement of the typical dose received by adult patients examined in a particular facility from either:-
 - (i) a particular type of radiograph
 - or (ii) a particular type of complete examination.

To meet these objectives the following two dose quantities are recommended:-

- (i) **Entrance Surface Dose** (including backscattered radiation) for individual radiographs.
- (ii) **Dose-Area Product** for complete examinations.

Other dose quantities exist which may be more closely related to the radiation risk to the patient, eg. organ doses, effective dose or the total energy imparted to the patient. They cannot however be measured directly and have to be inferred. Methods for deriving such quantities from the directly measurable quantities recommended in this protocol have been developed by NRPB and are being extended. These will increase the utility of the two recommended directly-measurable quantities which still, however, remain more practicable for periodic checks and comparisons of patient dose.

2 Choice of dosimeters

Thermoluminescent dosimeters are preferred to ionisation chambers for entrance surface dose measurements because they are small, unobtrusive and, if stuck directly to the skin, fully measure backscattered radiation. Ionisation chamber measurements in free air (without a patient or phantom) are not ruled out in suitable circumstances, but such measurements must be corrected using appropriate backscatter factors.

Specially designed large-area, transparent ionisation chambers are available for attaching to the diaphragm housing of x-ray sets to measure dose-area product, and are the recommended dosimeter for this purpose. They do not interfere with the examination and will integrate the dose both over the area of the x-ray beam and over complete examinations involving radiography and fluoroscopy.

It is expected that both types of measurements will usually be carried out by radiographers with the active assistance of medical physicists particularly in providing suitably

calibrated dosimeters. The protocol describes how both TLD systems and Dose-Area Product Meters should be calibrated and specifies desirable levels of accuracy.

3 Sample selection

Advice is given on how to select an appropriate measurement sample so that valid comparisons can be made between facilities and with national norms. The objective of the measurements is to obtain an indication of the typical dose that is being delivered to an average adult patient by the procedures and equipment used in a particular facility for the types of radiograph or examination under study. To meet this objective measurements should preferably be made on a representative sample of at least 10 adult patients rather than on phantoms or in free air.

It is recommended that dose measurements should concentrate on those types of radiograph and examination that make a significant contribution to the collective dose from medical x-ray examinations. These are indicated in Table 1 where reference dose values are also given. Measurements on other types of radiograph or examination which would provide useful information on the performance of a particular x-ray facility are not to be excluded, but for the majority of standard radiographic or fluoroscopic facilities, patient dose monitoring should be initially concentrated in the above areas. Computed Tomography and mammography are deliberately not covered by the protocol.

4 National collation of dose data and Reference Dose Levels

Important features of the Protocol are that it provides guideline reference doses based on earlier national surveys and it recommends a system for the continual national collation of patient doses. Users of the Protocol are encouraged to send their results to NRPB so that trends in patient dose can be analysed and reference doses based on national norms can be revised if necessary. At present, reference doses are based on the 3rd quartile values of the mean doses delivered by x-ray departments in a national patient dose survey conducted by NRPB in the mid 1980s.

Table 1. Reference dose values

Entrance Surface Dose per radiograph		(mGy)	Dose-Area Product per examination	(Gy.cm²)
Lumbar spine	AP	10	Lumbar spine	15
	Lat	30	Barium enema	60
	LSJ	40	Barium meal	20
Abdomen	AP	10	Intravenous	
Pelvis	AP	10	urography	40
Chest	PA	0.3	Abdomen	8
	Lat	1.5	Pelvis	5
Skull	AP	5.0		
	PA	5.0		
	Lat	3.0		

Since 75% of radiology departments can operate satisfactorily with mean doses below the third quartile values, it is recommended that those departments that are found to exceed this level should conduct thorough and immediate investigations into the reasons for their excessively high doses. The investigations either should lead to revisions in techniques or equipment to bring the doses into line with the majority or, exceptionally, should lead to a thorough justification of the need for high doses in that particular clinical circumstance. We believe that the reference levels correspond to the ICRP 60 (5) concept of a "dose constraint" for medical exposures.

The achievement of mean doses below the reference (3rd quartile) level should not be construed as an indication of satisfactory or optimum performance per se. It may well be possible to reduce doses further without loss to the diagnostic value of the examination and such reductions should always be pursued in line with the ALARA principle. However, particular attention should be paid to checking image quality if mean doses fall significantly below the 1st quartile values. Simple methods for checking image quality are outlined in the protocol.

CONCLUSIONS

Adherence to the procedures recommended in this protocol will ensure that radiologists and radiographers are kept aware of how the doses that they currently deliver to their patients compare with national norms so that they can bring them into line with modern accepted practice. The national collation of patient dose data will enable the impact of patient protection measures and trends in medical exposures in the UK to be assessed and the guideline reference doses to be revised if necessary.

REFERENCES

- 1 UNSCEAR, 1988. Sources, Effects and Risks of Ionising Radiation. 1988 Report to the General Assembly, with annexes. (United Nations, New York)
- 2 NRPB/RCR, 1990. Patient Dose Reduction in Diagnostic Radiology. Docs of the NRPB, Vol 1, No 3. (HMSO, London)
- 3 RCR, 1990. Making the Best Use of a Department of Radiology: Guidelines for Doctors. (RCR, London)
- 4 NRPB/IPSM/CoR, 1992. National Protocol for Patient Dose Measurements in Diagnostic Radiology. (NRPB, Chilton)
- 5 ICRP, 1991. 1990 Recommendations of the International Commission on Radiological Protection. (Pergamon Press, Oxford)

EXPOSITIONS AUX PATIENTS POUR QUELQUES EXAMENS RADIOGRAPHIQUES AU QUEBEC

R. Carrier, P. Charland

Département de physique biomédicale
Hôpital Notre-Dame de Montréal
1560 rue Sherbrooke Est, Montréal, Canada, H2L 4M1

ENTRANCE EXPOSURE FOR SEVERAL RADIOGRAPHIC EXAMINATIONS IN QUEBEC

More than one hundred radiographic rooms have been visited and measured. The technical parameters used by X-ray technologists have also been collected. These numbers have been put in a worksheet and results obtained for entrance exposure for the eight most frequent X-ray examinations. Large variations are observed and the results are comparable to other foreign evaluations. A correlation analysis with multiparameters have failed. The variation could not be explained by a general trend on the kV selections or processing speed or thickness of filtration.

INTRODUCTION

Des inspections de radioprotection doivent être faites dans toutes les salles de radiographie au moins à chaque deux ans, selon la réglementation du Québec. Dans le cadre de ces vérifications, nous avons mesuré pour chaque salle de radiographie visitée, les valeurs d'exposition aux différents kV, la précision de ces kV et la couche de demi-atténuation à 80 kV. Nous avons également relevé le type d'écrans intensificateurs utilisés et nous avons procédé à une mesure sensitométrique des conditions de développement des films. D'autres parts, nous avons demandé à la technicienne de la salle, de nous communiquer les différentes techniques utilisées pour 8 examens standards reconnus comme étant les plus fréquents, soit: crâne latéral, poumon PA et poumon latéral, colonne lombaire AP, colonne dorsale AP, colonne dorsale latérale, bassin AP, colonne cervicale AP. Les kV, temps de pose et courant, ainsi que la distance foyer-film nous ont ainsi été fournis.

C'est la compilation de ces informations et des calculs à partir de ces données et des valeurs mesurées qui nous ont permis d'obtenir les résultats que nous vous livrons dans cette présentation.

MATERIEL ET METHODES

Nous avons exprimé en introduction la nature des données recueillies. Ajoutons à cela que tous les examens considérés réfèrent à un patient masculin

de taille moyenne (72 kg). Toutes les mesures ont été faites avec un électromètre Keithley et une chambre d'ionisation Keithley 15cc. Les relevés de la précision des kV ont été faits avec un kVp mètre Victoreen. Les analyses sensitométriques ont été faites à partir de l'exposition d'un film par un sensitomètre Victoreen jugé constant pendant les 3 ans de l'étude. La lecture des densités a été faite avec un densitomètre Macbeth.

Les valeurs d'exposition à la surface du patient ont été calculées à partir des paramètres communiqués et des valeurs mesurées. Le calcul a été fait à l'aide du chiffrier Lotus 123. L'interpolation dans la table des kV a été faite selon une courbe d'ajustement du 4e degré. Nous avons, bien sûr, tenu compte de la distance foyer-film pour les différentes techniques et l'exposition à la surface a été corrigée par la loi de l'inverse du carré de la distance, tenant compte de l'épaisseur de l'organe, et de la distance patient-film. Les résultats du chiffrier sont très comparables aux résultats obtenus avec le logiciel JCAHDOSE distribué par Douglas J. Simpkin (1990).

Nous avons constaté à l'observation des données que pour le même examen radiographique, il y avait de grandes différences dans le choix des techniques radiographiques et à titre d'exemple en figure 1, on constate que pour un crâne latéral les choix de kV peuvent être aussi écartés que 30 kV. Nous avons également constaté de très grandes variations dans la sensibilité des films jumelés aux conditions de développement, ce que nous montre la figure 2. La banque de données inclut des salles travaillant avec des films sensibles au vert et d'autres films sensibles au bleu. De façon à rendre les choses comparables, nous avons divisés l'étude en deux catégories de films. La figure 3 montre la distribution des salles selon l'épaisseur de la couche de demi-atténuation à 80 kV. Certaines salles ont une filtration relativement faible et d'autres une très forte filtration ce qui a certainement une influence sur les expositions obtenues dans ces salles respectives.

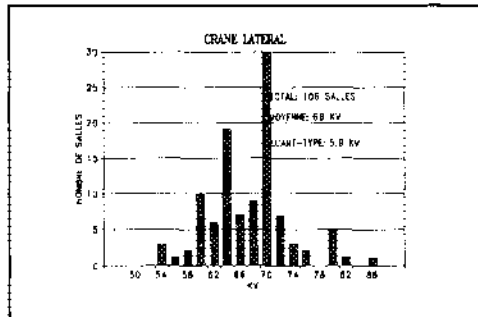

Figure 1 Répartition des kV utilisés pour réaliser une radiographie du crâne en latéral

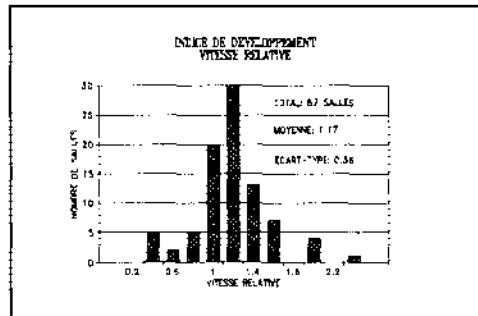

Figure 2 Répartition des sensibilités pour les 87 salles utilisant du films sensibles à la lumière verte.

RESULTATS

Les figures 4 à 11 présentent les histogrammes des résultats d'exposition à la surface des patients pour les 8 techniques considérées. Dans chaque cas, on observe un écart-type très significatif et ainsi de très grandes variations. La moyenne apparaît acceptable et suit les valeurs de l'étude américaine NEXT. Il apparaît que quelques cas significativement élevés nécessitent une correction importante ou aurait fait l'objet d'une erreur dans la transmission des données qui nous ont été communiquées.

Une analyse de corrélation multiple a été essayé et aucun paramètres n'a pu être placé dans une expression de régression avec un coefficient statistiquement significatif selon le test de Student.

CONCLUSION

Compte tenu des variations importantes qui ont été relevées, il nous apparaît que, malgré les réglementations nombreuses qui touchent les équipements, il y aurait place à un mécanisme orienteur au niveau de la standardisation et de l'optimisation des techniques et des appareillages.

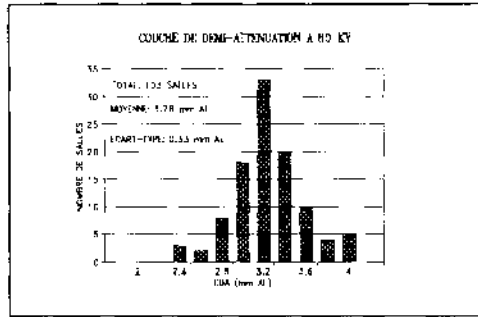

Figure 3 Répartition des CDA mesurées à 80 kV, en mm d'Al.

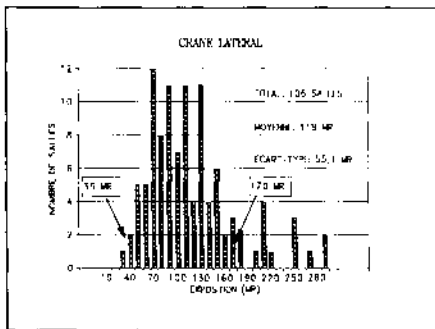

Figure 4 Exposition en mR pour un crâne latéral.

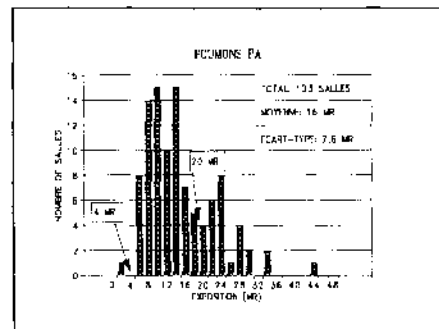

Figure 5 Exposition en mR pour une radiographie pulmonaire PA.

Six histogrammes additionnels montrant la répartition des expositions en mR.

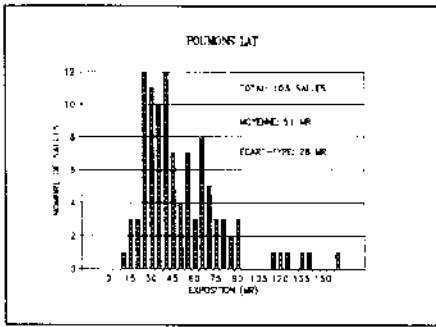

Figure 6 *Poumons en projection latérale*

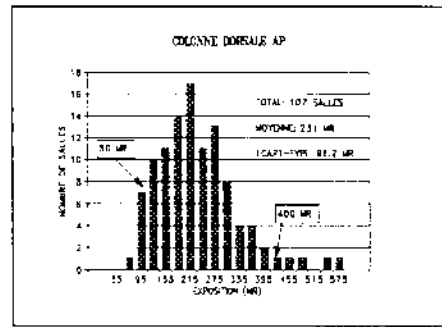

Figure 7 *Colonne dorsale en projection AP*

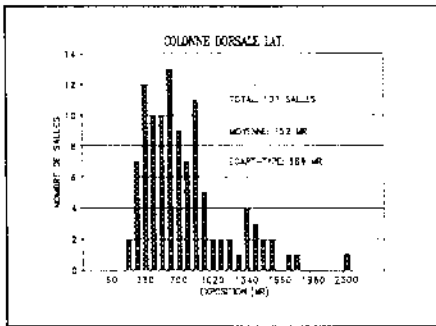

Figure 8 *Colonne dorsale en projection latérale.*

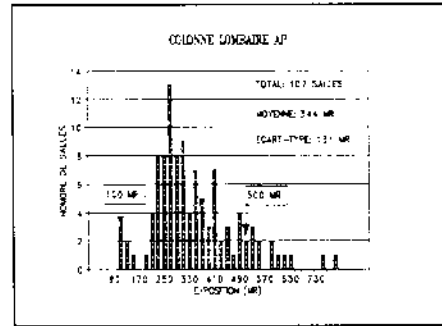

Figure 9 *Colonne lombaire en projection AP.*

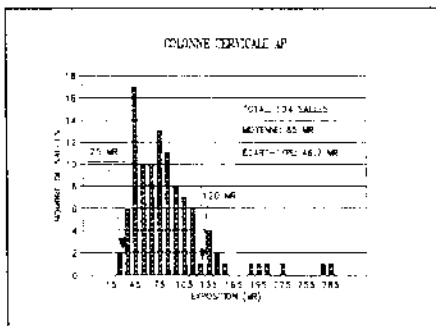

Figure 10 *Colonne cervicale en projection AP.*

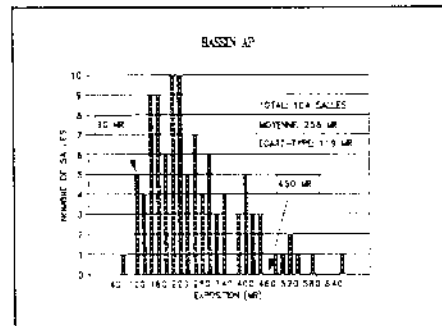

Figure 11 *Bassin en projection latérale.*

ESTIMATION OF EMBRYONIC DOSES IN RADIOLOGICAL EXAMINATION ON UPPER GI-TRACT IN JAPAN

K. Ohta, M. Kai and K. Kusama

Department of Radiological Health, Faculty of Medicine,
The University of Tokyo, Tokyo, Japan

ABSTRACT

Embryonic doses on X-ray health screening of upper GI-tract of about 100 subjects in five health screening facilities were investigated from viewpoints of optimization of protection in medicine. The embryonic doses were derived from the skin doses of each subject measured with TLDs and the examination procedures of upper GI-tract, i.e. duration times of fluoroscopy, numbers of fluorographies or radiographies, voltage and current during examination. The results are as follows: (1)Embryonic doses and skin doses on the maximum point in each subject ranged from 0.3 to 5.5 mGy and from 8.9 and 210 mGy, respectively, (2)Duration time of fluoroscopies and numbers of fluorographies or radiographies ranged from 0.6 to 7.6 min. and from 7 to 40 exposures, respectively.

INTRODUCTION

Per caput dose of medical exposure in Japan is 1.6 mSv; this is about 5 times higher than that of other advanced countries, i.e. United Kingdom[K1]. Immediate reduction of medical exposure is necessary. The X-ray examinations on upper GI-tract which contribute large effective dose to the population are very popular in Japan. The frequency of these examinations per 1000 population is 175(total number is about 19 million)[B1]. About 44% of these examinations are applied to females and about 10% of the female subjects are under years 30 of age[H1]. From viewpoints of radiation protection of embryo/fetus, exposure from these examinations should be reduced.

Because dose limitation is not applied to medical exposure, reduction of exposure should be performed by justification of practice and optimization of protection. X-ray examinations on upper GI-tract could be regarded as a typical diagnostic procedure. So dose constraint in optimization should be considered too[1].

In our previous studies it was made clear that doses of X-ray examinations on upper GI-tract were widely different among subjects. In order to estimate the distribution of embryo/fetus doses among subjects and facilities, we investigated the examination procedures of upper GI-tract and the skin doses in more than 100 subjects in five X-ray health screening facilities.

METHODS AND MATERIALS

The types of X-ray equipment investigated in this report in each health screening facility are shown in Table 1. The uterus doses of each subject were estimated by the following information;

- (1)Skin doses of each subject
- (2)Relationship between surface doses and uterus doses estimated by phantom experiments
- (3)Examination procedures of each subject.

The skin doses of each subject were measured by the following methods;

- (1)TLDs : Mg₂SiO₄:Tb(Kasei Optonix) and CaSO₄:Tm(Panasonic)
- (2)Reader: Victoreen model 2800M
- (3)Calibration: ionizing chamber(Capintec 192X with model PM-05 probe); 90 and 100 kVp X-ray in free air
- (4)Measuring points: front and back surface at 10 cm below xiphisternum, front and back surface at the position of uterus.

Total error of skin doses by the present methods was about 20%.

RESULTS

The investigated procedures of examinations are shown in Table 1. There were remarkable differences of duration time of fluoroscopies and numbers of exposures in gastro-duodenum examinations among facilities. Distribution of duration time of fluoroscopies is shown in Fig. 1. Duration time of fluoroscopies ranged from 0.6 to 7.6 min.

The points of the maximum skin doses were located at 10 cm below xiphisternum in the side of incident X-ray. The skin doses on the maximum point in each subject ranged from 8.9 and 210 mGy and distribution in each facility is shown in Table 1 and Fig. 2. Distribution of embryonic doses is shown in Table 1 and Fig. 3. The embryonic doses ranged from 0.3 mGy to 5.5 mGy.

DISCUSSION

It was made clear that embryonic doses and skin doses of each subject and facility distributed widely. These differences should be considered in estimation of the per caput dose from medical exposure in Japan. It seems that the different purpose of the X-ray health screening of upper GI-tract gave rise to the wide difference in the number of exposures and duration time of fluoroscopies. X-ray health screening of upper GI-tract is applied to healthy subjects as the first screening. So the purpose and the procedures of these should be reconsidered from viewpoints of justification and optimization.

The widely differing embryonic doses and skin doses on the maximum point indicate the necessity of application of dose constraint to X-ray health screening of upper GI-tract. The value of dose constraint must be considered on the basis of our present results.

REFERENCES

- B1 Bennet, B.G.: Exposure from Medical Radiation World-Wide, *Radiat. Prot. Dosimetry*, 36(2/4), 237-242(1991)
- H1 Hashizume, T., Maruyama, T., Noda and Fukuhisa, K.: Stochastic Risk Estimation from Medical X-ray Diagnostic examinations, 40(9), 885-897(1980)
- I1 ICRP Publ.60: 1990 Recommendations of the International Commission on Radiological Protection, *Annals of ICRP*, 21(1/3), Pergamon Press(1991)
- K1 Kusama T., Nakagawa T. and Yoshizawa Y.; Estimation of Population Dose from The Purpose of Radiation Protection of Public, *J. of the Japan Health Physics Society*, 20, 399-406(1985)

Table 1. Specification of X-ray examination Procedures and Summary of Results

	A	B	C1	C2	D	E
MODELS of X-ray equipment*	DT-AV	DDW-30A	DBW-30A	DAW-30A	ZU-A4M	DPT-500A
Types of procedures**	FL	RD	RD	RD	FL	FL
Total filtration (mmAl)	1.6	2.0	2.5	2.5	3.3	2.5
Subjects of investigation	55	20	11	10	23	48
Examinations of esophagus area						
Duration of fluoroscopy (min)	0.3±0.1	0.4±0.1	0.3±0.1	0.4±0.2	-	0.2±0.1
Number of exposure	1.0±0.0	3.8±0.6	2.8±1.0	2.0±0.0	-	1.8±0.8
Examinations of gastro-duodenum area						
Duration of fluoroscopy (min)	1.9±0.5	2.6±0.6	5.6±1.0	5.3±0.6	1.8±0.4	0.8±0.2
Number of exposure	8.6±0.8	20±1.7	27±3.2	28±2.4	7.0±0.0	8.3±0.7
Subjects measured with TLDs	50	19	11	10	15	-
Maximum skin doses(mGy)	20±8.9	36±21	76±36	123±52	99±45	-
Embryonic doses(mGy)	0.8±0.6	1.2±0.6	1.1±0.5	3.7±1.4	1.8±0.7	-

* DT-AV, SSW-30A and DAW-30A were under-tube type equipment of TOSHIBA, and DBW-30A(TOSHIBA), ZU-A4M(HITACHI) and DPT-500A(TOSHIBA) were over-tube type equipment.

** FL: fluorography, RD: radiography

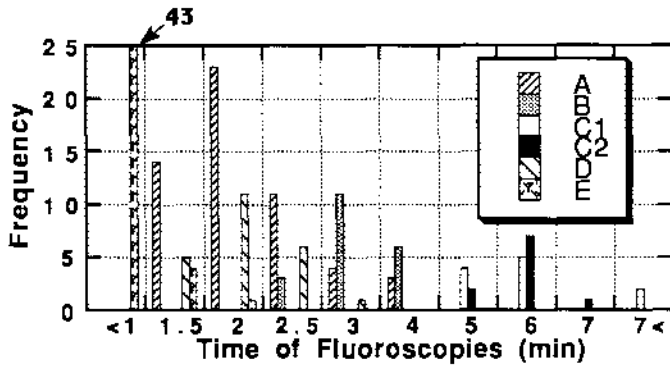

Fig.1 Distribution of duration time of fluoroscopies in gastro-duodenum area examinations

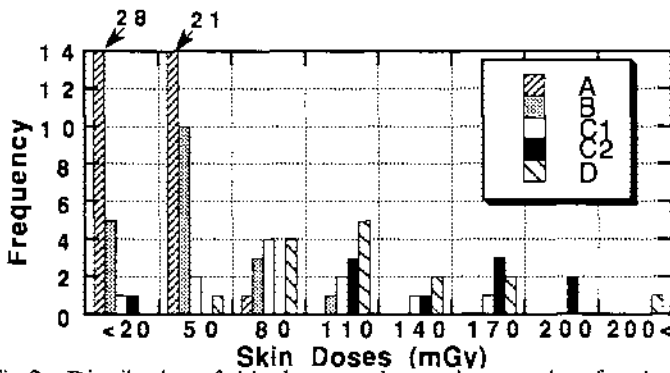

Fig.2 Distribution of skin doses on the maximum point of each subject in X-ray examination on upper GI-tract

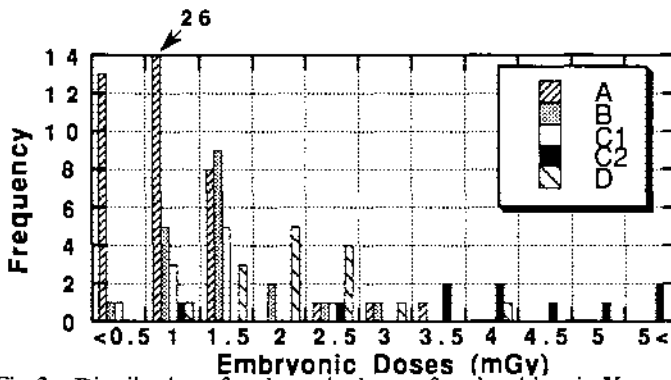

Fig.3 Distribution of embryonic doses of each subject in X-ray examination on upper GI-tract

POTENTIAL EXPOSURES IN RADIATION MEDICINE

César F. Arias

Comisión Nacional de Energía Atómica - Argentina

ABSTRACT

Accidental exposures have progressively caused greater concern along last years and the concept of potential exposures has been deeply explored in the new ICRP recommendations. Severe accidents have been produced by radiation sources employed in medicine. The particular way in which these sources are used enhances the probability of undesirable exposures of workers, members of the public and patients. Nevertheless safety of medical sources have frequently not deserved the same degree of attention as other radiation sources. The tools of probabilistic safety assesment can be applied to evaluate and improve the safety of these sources.

THE CONCEPT AND SIGNIFICANCE OF POTENTIAL EXPOSURES

Any practice with radiation sources implies the irradiation of persons in conditions that can be regarded as normal, what means that radiation doses will be received by people according to predictable patterns, and in any case below certain limits. This objective can be achieved through an appropriate design of equipment and facilities and imposing restrictions to people's behavior.

Nevertheless since devices and people may fail the possibility of accidents can never be ignored. When an accident occurs radiation doses becomes distributed in an unexpected way. The exposures that results from events which are not certain but that can not be disregarded are called potential exposures.

Normal exposures usually contributes more than accidental exposure to collective doses through different places and along the time. However accidental exposures may cause a concentration of effects in place and time that are not justifiable and are not accepted by public opinion.

In the new recommendations of the International Commission of Radiation Protection (1), potential exposures deserves the same consideration as planned exposures what implies a significant evolution from the previous recommendations (2).

Concern about a potential exposure refers to its posible severity and to the probability of occurrence. The severity of an accident depends on the distribution of doses it produces and the number of exposed individuals.

The probability of accidental events with radiation sources depends directly or indirectly on human factors. Sources where safety relies strongly on human behavior have greater probabilities for potential exposures; that is the case of movable sources and unsealed sources, for instance. Since radiation emissions of radioactive sources can not be controlled any radioisotopic source which is not longer used and has not been adequately disposed has a high potentiality for accidents.

POTENTIAL EXPOSURES RELATED TO MEDICAL RADIATION SOURCES

Medical sources are by far the most numerous and spread radiation sources any community has. According to UNSCEAR (3) in the world exist: 18.000 Radiation Therapy machines (4.300.000 procedures per year); 23.500 Nuclear Medicine machines (23.500.000 procedures per year); 440.000 X Rays machines (1.380 millones procedures per year).

These sources are located at buildings usually frequented by many people totally ignorant about radiation risks and radiation protection (members of public).

Some sources are fixed and have large activities. (teletherapy sources). Some others have lower activities and are movable (brachytherapy sources, nuclear medicine sources). The first ones can cause infrequent and severe accidents. The second ones can cause more frequent and less severe accidents.

Radiation safety of medical sources depends on the behavior of many people: phisicians, technicians, nurses, physicists, maintenance workers, and sometimes responsibilities for the sources control are not well defined. In some countries radiation risks and protection have been poorly known by personnel involved in medical application of radiation for a long time. Consequently, safety routines may have been very weak in thoses countries. Additionally, in some countries regulatory procedures related to medical sources are less stringent than for other sources. Such circumstances contributes significantly to raise the potentiality for accidents, in particular when radioactive sources are not longer in use.

Radiation accidents may cause the abnormal exposure of workers and members of the public. Medical sources are used within facilities normally open to general public. Potentiality for public implications is then significant for these sources. However the number of exposed people involved may be much higher if the accident extends outside the facility.

Patient potential risks must also be considered (particularly in radiation therapy). Accidental situation may occur when a patient receives wrong doses, (greater or smaller than expected); or wrongly localized; or when a righth dose is received by a wrong patient. Doses greater than prescribed involves over exposure risks while lower doses may be cause of treatment failure.

REVIEW OF SOME SIGNIFICANT ACCIDENTS PRODUCED BY MEDICAL RADIATION SOURCES

According to C. Lushbaugh (9) 101 fatalities attributable to radiological accidents have occurred between 1944 and 1989; 28 of them have been caused by medical sources. Non fatal accidents or incidents have involved many people; in U.S. during 1988; 470 patients were subjected to medical missadministrations; 438 in diagnostic procedures and 32 in radiation treatments. (2)

Medical radiation sources have caused overexposures to workers and members of the public as consequence of accidents. Patients have been subjected to missadministration of doses.

I) SOME SIGNIFICANT ACCIDENTS THAT HAVE PRODUCED DOSE MISSADMINISTRATIDN TO PATIENTS

- 1) 1986 - U.S. Texas - Linear accelerator unit (4)
Consequences: Two patients died after receiving doses of 200 Gy
Main cause: Wrong interaction between operator and computer.
- 2) 1988 - U.S. California - Tc^{99m} source employed in nuclear medicine (5)
Consequences: a patient received a dose 1000 times greater than prescribed.
Main cause: Failure in following protocol for radiopharmaceutical injections.
- 3) 1987 - 1988 U.S. Maryland - Co⁶⁰ therapy unit (5)
Consequences: 33 patients received doses exceding up to 75% prescribed values.
Main cause: Computer programme was not upgraded after source was changed.
- 4) 1990 - Spain - Zaragoza - Linear Accelerator unit (6)
Consequences: 27 patients were overexposed 14 died
Main cause: Wrong functioning of energy selector after maintenance procedure.

II) SOME SIGNIFICANT ACCIDENTS THAT HAVE PRODUCED OVEREXPOSURE IN WORKERS AND MEMBERS OF THE PUBLIC

- 1) 1965 - U.S. X Ray fluoroscopic equipment (7)
Consequences: Two workers suffer burns in hands
Main cause: Interlock failure during maintenance operations.
- 2) 1984 - México - Ciudad Juarez - Co⁶⁰ Therapy unit (8)
Consequences: 5 persons receives doses between 3 and 7 Gy - 80 persons received doses greated than 0,25 Gy; 814 building had to be demolished.
Main cause: A therapy equipment was disassembled without removing the source and 6000 cobalt pellets were dispersed into building materials.

3) 1987 - Brazil - Goiania - Cs137 Therapy unit (8)

Consequences: 4 persons (members of the public) died - 14 persons received doses greater than 1 Gy - 54 persons received doses greater than 0.25 Gy - 42 residences were contaminated and 4 had to be demolished.

Main cause: A no longer used source was abandoned without any safety measure.

PREVENTION OF ACCIDENTS WITH MEDICAL SOURCES

Accidents are part of the unpredictable future. But unpredictability refers to the time at what the event may occur, not to the characteristics of the event itself. Any possible accidental event can be described as a potential event before it may occur and the possible sequences of causes that lead to it can be identified. By assigning probability figures to equipment failures and to human failures the probabilities for undesirable accident can be calculated (Probabilistic safety assesment). By increasing redundancy in the safety systems, assuring their independency and minimizing the influence of human failures the probably of accidents can be reduced below acceptable limits.

By adopting these and other complementary means uncertainty about the future can not be completely avoided but prevention of accidents can be achieved on statistical basis.

This is the philosophy proposed by the ICRP for potential exposures and their application can be fully adopted for the safe employment of radiation sources in medicine.

REFERENCES

- 1) ICRP Publication N° 26 (1977)
- 2) ICRP Publication N° 50 (1990)
- 3) UNSCEAR 1988
- 4) C. Borras - Accidents with Medical Sources (1990)
- 5) NUREG Vol 3 N° 2 - Medical administration Report (1988)
- 6) Spain Society of Medical Physics (1991)
- 7) UNSCEAR (1982)
- 8) C.C. Lushbaugh Radiological Accidents (1989)
- 9) C.C. Lushbaugh An Historical Perspective of Human Involvement in Radiation Accidents (1990)

DIRECT MAGNIFICATION RADIOGRAPHY AND PATIENT EXPOSURE

J. Schütz, H.-L.Kronholz and G. Reuther*

Klinik und Poliklinik für Strahlentherapie
*Institut für Klinische Radiologie
Westfälische Wilhelms-Universität Münster
Münster, Germany

ABSTRACT

Direct magnification radiography (size of focal spot of X-ray tube 0,010 mm) visualizes details below the threshold of standard radiography. In combination with high speed film/screen systems up to a fourfold magnification the exposure of a normal radiogram is not exceeded. In this respect Digital Luminescence Radiography (DLR) with its high speed and imageprocessing capability is ideally suited.

INTRODUCTION

Radiographic objects contain innumerable details varying in size and contrast. Direct magnification radiography visualizes details below the threshold of standard radiography [1,2,3,4,5,6]. A microfocal tube, however, is a prerequisite for direct magnification. At University of Münster a microfocal tube with a size of focal spot of 0,01 mm is in clinical use, a second one with a size of the focal spot of 0,001 mm is used experimentally.

As magnification ratio is inversely related to the spatial resolution of the film/screen, best resolution is achieved when the geometrical blurring of the microfocus and the film/screen system are equal [7]. This is called the optimum magnification ratio [8,9]. A magnification exceeding the optimum ratio leads to overmagnification with further gain in resolution [10]. A small degree of overmagnification will be tolerated despite some blurring as larger objects are perceived more easily.

CONCLUSIONS

Up to a fourfold magnification the patient exposure of a normal radiogram will not be exceeded due to the air gap between patient and film that renders anti-scatter grids unnecessary and due to the necessity for high speed film/screen systems. Filter materials are crucial to patient exposure as well. Investigations with different filter materials proved K-edge filters of no value except for mammography [11,12]. Al-filters should be the

material of choice for any other application.

As low spatial resolution of film/screen systems may be compensated to a large extent by direct magnification the application of digital luminescence radiography seems to be ideally suited. The full range of contrast enhancement and image processing capabilities becomes available at the unrivaled spatial resolution of radiographic imaging. This may be of special interest in direct magnification mammography as well.

For clinical use the following combinations of size of the focal spot and film/screen are specially suited:

type of image	focus size (μm)	magnification	filter (μm)	exposure (cGy)	time (s)	screen/film system speed (S)	resolution (mm)
mammogr. 30 kV	25	2	76 Mo	0,30	9,5	0,002 cGy S = 50	< 0,09
tissue 40 kV	25	2	1500 Al	0,10	2,2	0,001 cGy S = 100	< 0,09
fluoroscop 100 kV	100	5	50 Cu	0,45	0,2	0,0005 cGy S = 200	< 0,120

Object 5 cm, focus-film distance 60 cm (mammography)
others 90 cm.

REFERENCES

1. Reuther, G., Kronholz, H.-L., 1991, Direktradiographische Vergrößerung in Kombination mit digitaler Radiographie für Skellettdiagnostik, Radiologe 31:424-429
2. Poulsen Nautrup, C., Berens von Rautenfels, D., 1991, Direktradiographische Vergrößerung in der experimentellen Medizin, Radiologe 31:430-434.
3. Hüttenbrink, K.B., 1991, Direkte radiographische Vergrößerung in der experimentellen Hals-Nasen-Ohrenheilkunde, Radiologe 31:435-438.
4. Wahl, G., Hüttenbrink, K.B. 1991, Direktradiographische Vergrößerung in der experimentellen Zahn-, Mund- und Kieferheilkunde, Radiologe 31:439-442.
5. Winkler, S., Richter, K.-D., 1991, Direktradiographische Vergrößerung bei Knocheninfektionen, Radiologe 31:447-451

6. Bajonowski, T., et al, 1991, Direktradiographische Vergrößerung in der forensischen Medizin, Radiologe 31:452-455.
7. Stargard, A., Angerstein, W., 1975, Der optimale Abbildungsmaßstab bei der direkten Röntgenvergrößerung, Fortschr Geb Röntgenstr 123:73-78
8. Ferrant, W., San Nicolo, M.R., 1954, Die förderliche Röntgenvergrößerung, Fortschr Geb Röntgenstr 81:194-295
9. Rosenkranz, G. et al, 1975, Ermittlung eines optimalen Vergrößerungsfaktors mittels objektiver und subjektiver Bildgütekriterien, Radiologica diagnostica 16:429-435
10. Angerstein, W., et al, 1987, Grundlagen der Strahlenphysik und der radiologischen Technik in der Medizin, Thieme, Leipzig.
11. Kronholz, H.-L., 1991, Direktradiographische Vergrößerung und Strahlenexposition, Radiologe 31:413-417
12. Nagel, H.D., 1989, Comparison of the performance characteristics of conventional and K-edge filters in general diagnostic radiology, Phys Med Biol 34:1269-1287

**DOSES AND DETRIMENT TO PATIENTS
FROM VASCULAR AND INTERVENTIONAL RADIOLOGY**

F. Diaz-Romero and J. Hernandez-Armas

Hospital Universitario de Canarias,
Tenerife, Canary Islands, Spain.

ABSTRACT

A survey was conducted on 1389 patients to establish the representative values of doses for different types of vascular and interventional X-ray examinations in Tenerife (Spain). Two large-area transmission ionization chambers were used for the measurements and a Monte Carlo computer program for calculations. Tabulated results of characteristic quantities for each type of procedure are presented. The collective effective equivalent dose is 9 man-Sv. The detriment, following ICRP-26, was 0.077, and 0.092 when all stochastic effects were taken into account.

INTRODUCTION

Vascular-Interventional Radiology (VIR) is a merging of classical vascular diagnostic radiology and new interventional radiology, developed from the Seldinger technique and applied in the field of therapy in addition to that of diagnosis. In VIR procedures two X-ray beams (radiography and fluoroscopy) are normally used to study patients' different anatomical areas. These procedures routinely involve several films, each of which would be difficult to classify in standard views. In fluoroscopic screening the radiologist may spend several minutes manipulating the position or the size of the X-ray beam over the region of interest. Although the doses to patients in VIR procedures are highest between X-ray examinations, the radiological impact on the population is small because of the low frequency involved with these types of procedures. The dosimetric data for some procedures carried out in France are presented in a paper published by Maccia et al. (1).

In the present paper the results for 8 different vascular and interventional radiology examinations and procedures are given. The patients were inhabitants of the province of Tenerife (Canary Islands), which has a population of approximately 700,000.

EXPERIMENTAL MEASUREMENTS

1830 VIR procedures of 1389 patients were studied. To obtain dosimetric data, two large-area transmission ionization chambers (Diamentor, PTW) were used. With this equipment the dose-area product for 435 procedures was obtained using the cameras for each X-ray tube (radiography and fluoroscopy). The sample is representative of the total number of studies. In all procedures technical and medical parameters were registered. To determine the dose-area product for each procedure, we found the corresponding figure per unit of mAs, irradiated area and number of radiographs or fluoroscopy screening times. When the dose-area

product was known, the entrance skin dose (ESD) and energy imparted (EI) to each patient were calculated. The value of EI can be used as a measure of radiological effect on patients. Our results are shown in Table 1.

TABLE 1.- MEANS (with CV %) OF DOSE-AREA PRODUCTS, ENTRANCE SKIN DOSES AND ENERGY IMPARTED PER PROCEDURE.

	NUMBER OF PROCEDURES	DOSE-AREA PRODUCT ₁ (cGyxcm ₂)		ENTRANCE SKIN DOSE (mGy)		ENERGY IMPARTED (mJ)
		radio- graphy	fluoro- scopy	radio- graphy	fluoro- scopy	
THORACIC ARTERIOGRAPHY	68	2381 (37)	180 (98)	39 (37)	13 (99)	180 (35)
ABDOMINAL ARTERIOGRAPHY LIMBS	440	5047 (41)	574 (124)	120 (46)	43 (137)	405 (44)
ARTERIOGRAPHY						
Upper	51	607 (107)	197 (99)	1622 (109)	1715 (99)	62 (90)
Lower	380	2758 (44)	213 (192)	6017 (58)	1843 (193)	207 (45)
PHLEBOGRAPHY						
Abdominal	36	1768 (70)	195 (148)	6924 (64)	2450 (132)	144 (77)
Upper limbs	42	382 (124)	0	704 (57)	0	29 (145)
Lower limbs	263	697 (58)	0	1645 (32)	0	45 (42)
EMBOLIZATION	43	4064 (81)	1948 (92)	90 (74)	147 (92)	470 (64)
ANGIOPLASTY	56	2906 (77)	1310 (77)	66 (86)	99 (77)	329 (62)
BILIARY PROCEDURES	82	1764 (67)	1953 (84)	38 (66)	148 (92)	337 (63)
NEFRO-URINARY PROCEDURES	338	444 (205)	750 (153)	17 (203)	57 (110)	159 (153)
MISCELLANEOUS	33	199 (70)	583 (105)	52 (63)	44 (105)	173 (85)

We used the ESD values to calculate the organ doses, with the aid of a PC computer program, based on the Monte Carlo method, supplied by the Center for Devices and Radiological Health, Rockville, Maryland. This program did not give us the doses for breast, bone and "remainder". We assume the hypothesis of a constant relationship between doses to near anatomical organs when they are explored by X-ray with similar projections (irradiated area, technical parameters, etc.). The values of individual organ doses presented by Jones and Wall (2) were used to obtain those relationships. Hence our results, which are shown in Table 2.

TABLE 2.- MEANS (with CV %) OF ORGAN DOSES (mGy) AND EED (mSv).

	RED LUNG	BONE Marrow	THYROID	TRUNK	GONADS	UTERUS	BONE	BREAST	REMAINDER	EED
THORACIC ARTERIOGRAPHY	9.7 (35)	1.4 (35)	36.1 (37)	3.3 (34)	0.00	0.00	3.5	21.1	3.2	5.5
ABDOMINAL ARTERIOGRAPHY	6.2 (60)	4.6 (47)	0.04 (107)	14.1 (40)	5.0 (160)	14.8 (62)	7.8	3.0	33.3	12.5
LIMBS ARTERIOGRAPHY										
Upper	0.2 (300)	0.2 (88)	0.00 (407)	0.7 (87)	0.2 (217)	0.2 (110)	0.6	0.03	0.2	0.2
Lower	0.05 (51)	2.1 (52)	0.00 (84)	6.8 (49)	5.0 (82)	14.2 (49)	4.2	0.1	15.6	6.3
PHLEBOGRAPHY										
Abdominal	0.9 (213)	1.5 (89)	0.08 (367)	4.6 (78)	8.8 (91)	8.4 (53)	2.5	0.4	10.6	5.8
Upper limbs	0.02 (72)	0.1 (103)	0.00 (419)	0.4 (87)	0.2 (119)	0.1 (61)	0.3	0.00	0.1	0.1
Lower limbs	0.00 (66)	0.3 (81)	0.00 (123)	1.2 (83)	1.5 (69)	2.9 (45)	0.6	0.00	2.8	1.3
EMBOLIZATION	8.4 (121)	6.1 (76)	0.1 (305)	11.8 (79)	3.7 (164)	8.1 (111)	9.2	3.9	24.1	9.8
ANGIOPLASTY	2.0 (149)	4.3 (73)	0.01 (121)	8.6 (78)	4.5 (116)	7.7 (92)	6.3	1.6	18.1	7.5
BILIARY PROCEDURES	3.9 (68)	3.8 (67)	0.02 (69)	6.7 (57)	0.5 (208)	2.0 (70)	5.3	1.4	13.0	4.8
NEFRO-URINARY PROCEDURES	0.9 (119)	1.5 (98)	0.00 (133)	2.1 (79)	0.7 (221)	1.2 (155)	2.1	0.3	3.9	1.6
MISCELLANEOUS	14.5 (67)	7.1 (44)	0.1 (54)	20.0 (40)	4.9 (155)	9.4 (67)	10.4	6.7	42.5	4.0

Our values for organ doses and equivalent effective doses are, generally, lower than those presented by Maccia et al., although it is difficult to draw a comparison since we are unfamiliar with some of the technical aspects of their examinations.

The calculation of detriment poses some difficulties because the ICRP-26 (3) definition contains a certain degree of ambiguity. In fact, we obtained the detriment (fatal and severe hereditary effects) using the risk factors proposed in the above publication although modified by the factors of probability of expression as a function of age at exposure proposed by Wall (4). The relationship between energy imparted and detriment as presented by this author has been used by us to derive another value for detriment. To obtain the detriment corresponding to all stochastic effects we have used the above risk factors and the mortality rates as severity factors. The values were 0.077 (for the two first methods) and 0.092 for the last one. The values were corrected where clinical terminal patients were not considered. Account was also taken of this consideration in calculating the value of the collective effective equivalent dose (CEED). The correction can be established at 15% lower than the uncorrected values.

CONCLUSIONS

- 1.- EED (mSv) and EI (mJ) for VIR procedures are related by the expression: $E=0.025 EI^{0.59}$.
- 2.- CEED due to 1830 VIR procedures in Tenerife was 9 man-Sv. The dose rate per 100,000 inhabitants of Tenerife in 1990 was estimated to be 0.7 man-Sv.
- 3.- The relationship between detriment for stochastic effects (Dse) and EI(mJ) can be formulated by: $Dse=4375 EI^{0.897}$.

REFERENCES

- 1.- Maccia, C., Benedittini, M., Lefaure, C., Fagnani, F., DOSES TO PATIENTS FROM DIAGNOSTIC X-RAY EXAMINATIONS IN FRANCE, Advanced seminar on diagnostic radiology dosimetry, Ispra, May 1987.
- 2.- Jones, D.G., 1985, and Wall, B.F., ORGAN DOSES FROM MEDICAL X-RAY EXAMINATIONS CALCULATED USING MONTE CARLO TECHNIQUES, N.R.P.B.-R186. Chilton, Didcot, Oxon OX11 0RQ. Sep. 1985.
- 3.- ICRP, 1977, RECOMMENDATIONS OF THE INTERNATIONAL COMMISSION ON RADIOLOGICAL PROTECTION, ICRP publication 26, Pergamon Press, Oxford. 1977.
- 4.- Wall, B.F., 1988, Harrison, R.M. and Spiers, F.W., PATIENT DOSIMETRY TECHNIQUES IN DIAGNOSTIC RADIOLOGY, The Institute of Physical Sciences in Medicine Report n 53, 2 Low Ousegate, York YO1 1QU. 1988.

A COMPARISON OF THE EFFECTIVE DOSE EQUIVALENT, H_E , WITH THE WEIGHTED DOSE, W_D , FOR THE SIX-YEAR-OLD PEDIATRIC PATIENT EXPOSED TO CT EXAMINATIONS. J.C. Blechinger, J.R. Prince, Pediatric Radiological Research Laboratory, Department of Radiological Sciences, University of Oklahoma Health Sciences Center, Oklahoma City, Oklahoma 73190.

The effective dose equivalent, H_E , introduced by the ICRP to describe radiation risks to radiation workers, has since been applied to members of the general public. Although some data are available on H_E 's from medical exposure to CT, no data are available for pediatric exposures. We present estimates of H_E from a GE 9800 CT scanner for the 6-year-old pediatric patient and compare these data to the weighted dose, W_D , proposed by Beninson and Sowby [1].

The computed tomography dose index (CTDI) was measured and compared to the literature [2]. CTDI data were then used to estimate organ doses from data in [2]. Ponderation factors from [1] were used to calculate W_D for both male and female patients.

The measured CTDI was 1.2 cGy/100 mAs at 120 kVp. Results of H_E and W_D calculations are summarized in Table 1.

Table 1. Estimates of H_E and W_D for the 6-year-old pediatric patient for various CT examinations in Sv/Gy.

Examination	# of Slices	H_E	W_D (Males)	W_D (Females)
Head	11	0.041	0.042	0.043
Chest	14	0.252	0.132	0.443
Abdomen	12	0.120	0.105	0.207
Torso	30	0.705	0.605	1.276

There are substantial differences in risk factors estimated from H_E and W_D . There is also a substantial difference in risk factors between male and females in this age group.

- [1] Beninson D, Sowby D: Radiat. Prot. Dosim. 11:57 (1985)
 [2] Fearon T, Vucich J: AJR 148:171 (1987).

A COMPARISON OF THE EFFECTIVE DOSE EQUIVALENT, H_E , WITH THE WEIGHTED DOSE, W_D , FOR THE SIX-YEAR-OLD PEDIATRIC PATIENT EXPOSED TO CT EXAMINATIONS. J.C. Blechinger, J.R. Prince, Pediatric Radiological Research Laboratory, Department of Radiological Sciences, University of Oklahoma Health Sciences Center, Oklahoma City, Oklahoma 73190.

The effective dose equivalent, H_E , introduced by the ICRP to describe radiation risks to radiation workers, has since been applied to members of the general public. Although some data are available on H_E 's from medical exposure to CT, no data are available for pediatric exposures. We present estimates of H_E from a GE 9800 CT scanner for the 6-year-old pediatric patient and compare these data to the weighted dose, W_D , proposed by Beninson and Sowby [1].

The computed tomography dose index (CTDI) was measured and compared to the literature [2]. CTDI data were then used to estimate organ doses from data in [2]. Ponderation factors from [1] were used to calculate W_D for both male and female patients.

The measured CTDI was 1.2 cGy/100 mAs at 120 kVp. Results of H_E and W_D calculations are summarized in Table 1.

Table 1. Estimates of H_E and W_D for the 6-year-old pediatric patient for various CT examinations in Sv/Gy.

Examination	# of Slices	H_E	W_D (Males)	W_D (Females)
Head	11	0.041	0.042	0.043
Chest	14	0.252	0.132	0.443
Abdomen	12	0.120	0.105	0.207
Torso	30	0.705	0.605	1.276

There are substantial differences in risk factors estimated from H_E and W_D . There is also a substantial difference in risk factors between male and females in this age group.

- [1] Beninson D, Sowby D: Radiat. Prot. Dosim. 11:57 (1985)
 [2] Fearon T, Vucich J: AJR 148:171 (1987).

DOSIMETRIC EVALUATION PROGRAM FOR DENTAL RADIOLOGY PRACTICES

Gregori, B.; Milat*, J.; Fernández, J.; Micinquevich, S.; Andrieu, J

Comisión Nacional de Energía Atómica
Gerencia de Seguridad Radiológica y Nuclear
* Facultad de Odontología, Universidad Nacional de La Plata
\$ Ministerio de Salud de la Pcia. de Buenos Aires
República Argentina

ABSTRACT

The preliminary results of a program undertaken to estimate the doses to patients associated with dental radiology practices in Argentine, are presented.

Information collected from the search demonstrated that the Dieck and coronal techniques are the most commonly used practices, while all the examinations are performed by using a circular collimator. For both practices, the dosimetric studies were carried out on a Rando Alderson phantom. All dose measurements were made using thermoluminescent detectors LiF and CaF₂. In addition, a mathematical model was developed by applying the Monte Carlo method to a MIRD-V phantom. Circular and rectangular collimators were used.

Absorbed dose distribution on head and neck, as well as surface dose distribution, were estimated. The comparison of the performance of both collimators shows that the use of the rectangular one allows for a dose reduction of 80%. Besides, a good correlation between the physical and mathematical models applied was found.

INTRODUCTION

The preliminary results of a program undertaken to estimate the doses to patients associated with dental radiology practices in Argentina are presented. This program includes the following steps:

- a) a statewide survey was carried out on unidentified professionals involved in dental radiology in order to obtain information on the radiology techniques applied, irradiation conditions, number of examinations, etc.;
- b) dosimetric assessments concerning dental radiology practices;
- c) analysis of the working sites;
- d) recommendations on optimization of radiology practices.

Over a total of 1200 dentist resident at La Plata city, there were 300 of them surveyed. The survey showed the following results:

- The techniques most frequently used are: Dieck (41.8%); four film interproximal (coronal) (24.1%); occlusal (16.5%); Fitzgerald (10.7%); extraoral (7%). In all cases, circular collimation was used.
- Film type : 3 x 4 cm² (35.2%)
- Operation voltage: 80 kVp (32.3%), 65 kVp (29.8%)
- Operation current: 10 mA (87.7%)
- Exposure time : from 0.1 s to 1 s (76.5%)

-Image analysis : visual (100%)

Up today, dosimetric data was attained regarding both Dieck and coronal techniques. For the former, the assessed practice consisted in 14 consecutive exposures of the upper maxilar and the mandible, while for the latter, 4 exposures of premolar and molar teeth were performed.

DOSIMETRIC ASSESSMENT

The dosimetric assessment was carried out by using a physical model based upon an equivalent tissue phantom RANDO (Alderson) and LiF and CaF₂ thermoluminiscent detectors. By distributing them in the inner parts and on the surface of the head, the neck and the trunk, absorbed doses in organs and tissues were evaluated.

Two types of collimators were used, a circular one (CC) and a rectangular one (RC). The performance of the latter was assessed.

The irradiations were made by using an OSO X-ray unit, with an operation voltage and a current of 60 kVp and 10 mA, respectively. Both collimators, 7 cm diameter window CC, and 3 x 4 cm² window RC, were used with a 15 cm focus-skin distance.

Tables 1 and 2 show the corresponding results. Mean absorbed doses exceeding $5 \cdot 10^{-2}$ mGy are presented. Figures 1 and 2 show the distribution of the mean superficial doses in the head and in the neck.

An overall error of 20% may be assigned to the expressed results. The main contributions to this error may be described as follows: a) Use of a mean mass attenuation coefficient, not fully representative of the energy distribution inside the phantom; b) Errors in the assigned mass fraction of an organ in the phantom slabs.

As an alternative, a mathematical model based upon the application of the Monte Carlo method to the photon transport in the MIRD-V phantom was used [1]. In order to improve the dosimetric evaluation in the head and the neck, the MIRD-V phantom was modified by including an upper maxilar, a mandible and parotid, sublingual and submaxilar glands. The X-ray spectra at the output of each collimator was simulated, as well as the shadow of the incident beam on the phantom surface.

The results corresponding to Dieck's technique are shown in Table 3. Only absorbed doses with a variation coefficient less than 5% are presented.

CONCLUSIONS

The evaluation of the information recalled from the professionals showed that the working conditions are satisfactory enough as to allow the obtention of the necessary image quality for a proper diagnosis.

Dosimetric data demonstrate that the use of a RC implies a reduction of the absorbed dose in the lens of two orders of magnitude, and, as a mean, a five fold dose reduction for the other organs. This significant dose reduction may be explained by the lessening of the exposure area, without diminishing the diagnosis quality. Absorbed doses in trunk organs are not significant.

Results obtained with the two models do not differ more than 15%, for those organs described in a similar way in both phantoms, while the difference increases to 30% for sublingual and submaxilar glands, which are not easily localized in the RANDO phantom. The above mentioned results justifies the use of the mathematical model in future dosimetric assessments.

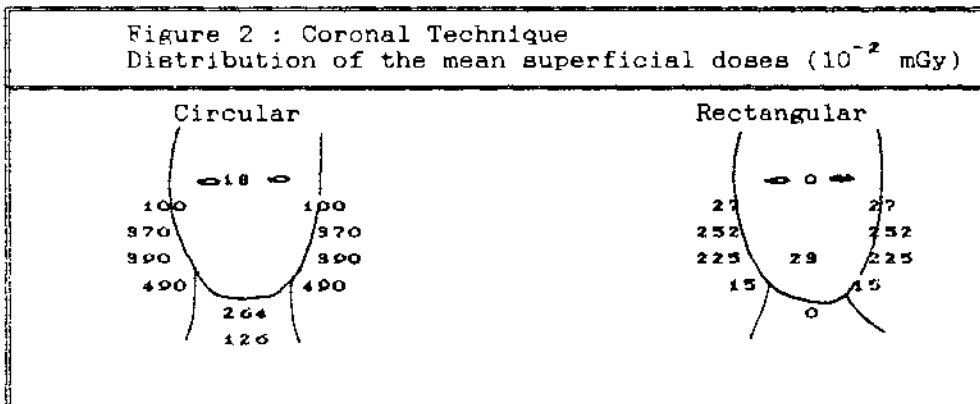
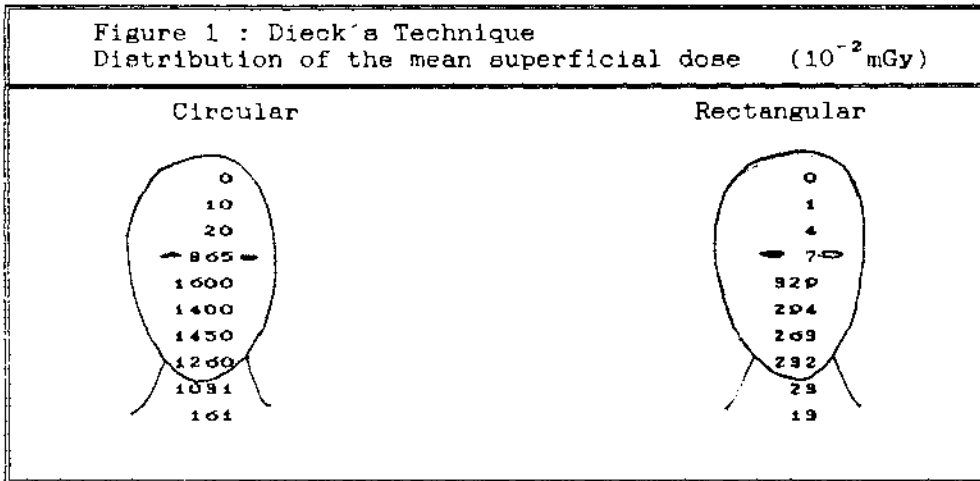

REFERENCES

1-Spano, F.; Thomasz, E.; Modelo de exposición en campos externos de radiación. Primer Congreso de la Sociedad Argentina de Radioprotección, Buenos Aires, 1983.

Table 1
Physical model
Absorbed doses distributions in Dieck's Technique
(10^{-2} mGy)

organ	Circular	Rectangular
RBM skull	*	*
RBM mandible	30.8	*
parotid glands	604.	142.
sublingual glands	540.	78.
submaxilar glands	41.	*
head skin (mean)	1214.	324.
lens of the eyes	885.5	7.
thyroid	51.	*
brain	8.	*

note: * less than 5×10^{-2} mGy

Table 2
Physical model
Absorbed doses distributions in coronal's Technique
(10^{-2} mGy)

organ	C. Circular	Rectangular
RBM skull	*	*
RBM mandible	*	*
parotid glands	250.	213.
sublingual glands	60.	24.
submaxilar glands	30.	21.
head skin		200.
lens of the eyes	18.	*
thyroid	41.	9.
brain	*	*

note: * less than 5×10^{-2} mGy

Table 3
mathematic model
Absorbed doses distributions in Dieck's Technique
(10^{-2} mGy)

organ	Circular	Rectangular
RBM skull	4.	.15
RBM mandible	29.	2.
parotid glands	630.	123.
sublingual glands	419.	*
submaxilar glands	33.	*
head skin (mean)	1100.	351.
lens of the eyes	832.	*
thyroid	61.	4.
brain	8.	.12

note: * variation coefficient great than 5 %

ASSESSMENT OF PATIENT SKIN DOSES IN DIAGNOSTIC RADIOLOGY

J.P. Wade, K.E. Goldstone and P.P. Dendy

East Anglian Regional Radiation Protection Service
and Medical Physics Department
Addenbrooke's Hospital
Cambridge, England

ABSTRACT

In the light of recent UK legislation and the increased awareness of patient doses by the general public, there was a need for more extensive direct measurement of the doses received by patients. A program was introduced in Autumn 1990, in the East Anglian Health Region to monitor the skin entrance doses for a range of common radiographic procedures. The results already obtained have raised questions about the suitability of some of the equipment and techniques used. For very low doses the relationship between dose and image quality is also being investigated.

INTRODUCTION

In the last few years there has been much interest in reducing the doses received by patients during routine diagnostic x-ray investigations. In the U.K. this has been backed up in legislation by the Ionising Radiation (Protection of Persons Undergoing Medical Examination or Treatment) Regulations 1988 which require a person physically directing an exposure to ensure the dose is as low as reasonably practicable while achieving the required diagnostic result. Furthermore, x-ray departments are required to formulate a strategy for dose reduction.

The National Radiological Protection Board (NRPB) with the Royal College of Radiologists (RCR) published a report on "Patient Dose Reduction in Diagnostic Radiology" (1) where it is recommended that each x-ray department should make measurements on skin entrance doses and these should be compared with national norms and, in time, their own previous results. As very few x-ray departments have the facilities for doing this, the East Anglian Regional Radiation Protection Service undertook the task of providing this service for all the x-ray departments in the East Anglian Health Region, in both the public and private sectors.

PROGRAM ORGANISATION

Because of the geographical spread of the x-ray departments involved in this program, a postal system had to be used. Batches of sachets containing thermoluminescent dosimeters (TLD) were sent out to each participating x-ray department with an instruction sheet, record sheet and padded return envelope. The TLD's used are lithium fluoride extruded chips which were read out in a Toledo reader; the batch was calibrated for diagnostic energies and all doses are quoted for diagnostic energies. On the record sheet details of the exposure factors (kVp, mA and time), focus-film distance and whether an automatic exposure control device had been used were recorded, and space was provided to attach the exposed TLD sachets. The instruction sheet included advice on the selection of patients for dose measurements; patients were to be of average size and no children under 16 years of age were to be included. The TLD sachet (which contains two chips) was stuck on to the patient at the centre of the entrance field during the radiographic view being measured. Where a repeat radiograph was required, the TLD sachet was to be left on the patient for the repeat and this would reflect the dose actually received by the patient. The TLD's and record sheet were returned to the Radiation Protection Service for processing and the x-ray department was informed of the results.

Thirty six x-ray departments, eight of which are in private hospitals or clinics, have participated in one or more parts of the study. Each participating department was issued with an identifying code which was used in all correspondence and in particular when results were sent out and comparisons between departments were made. A selection of simple radiographic views have been chosen, covering a range of anatomy and exposure factors. The views selected were AP Abdomen, PA Chest, Lateral Lumbar Spine and Lateral Skull. The average entrance dose for each department was then compared to guideline doses recommended by the NRPB (2) for the radiographic view being studied. Any department with average doses above the guideline dose was contacted with a view to reducing their doses by looking at the techniques and equipment used.

DOSE RESULTS

For the AP Abdomen view the individual entrance doses ranged from 0.97 to 41.6 mGy with an average of 7.9 ± 6.5 mGy and the departmental average doses varied from 3.7 mGy up to 19.4 mGy. Every department with an average dose over 10 mGy (the guideline dose for AP Abdomen) was contacted with a view to assessing how dose reductions might be made and several

departments have already made changes which have resulted in dose reductions up to 65% with very little reduction of image quality. Examples of changes have included the change of film/screen combination or the change in kVp where the response of the film/screen combination is energy dependent.

From early results on PA Chest skin entrance doses it rapidly became apparent that two very different radiographic techniques were being employed. The first technique uses 60-75 kVp and a chest stand without a grid; this is good for imaging the soft tissue in the lungs. For this technique the average skin entrance dose measured was 0.16 mGy with a range of 0.01 mGy (the minimum dose measurable) to 0.88 mGy. The second technique utilises 120 - 130 kVp and a high factor grid in the chest bucky. The average skin dose for this technique was 0.25 mGy with a range 0.01 to 1.57 mGy. The departmental average skin doses varied from 0.04 mGy up to 0.48 mGy. The NRPB guideline dose for PA chest is 0.3 mGy. In our survey all the departments with average doses greater than this were using the high kVp technique. These results and their implications are being discussed elsewhere (British Institute of Radiology Annual Conference, Birmingham England, May 1992).

For lateral lumbar spine radiographs the individual entrance doses range from 3.2 mGy up to 103.8 mGy with an average of 19.3 mGy. The departmental average doses vary from 6.6mGy up to 45.3 mGy; the NRPB guideline dose is 30 mGy. The departments with higher than average doses were those which also showed higher than average doses for AP Abdomens but for various reasons have not yet made any dose-reducing changes to their equipment and/or techniques.

Skin entrance dose measurements have not yet been made on lateral skull radiographs.

PATIENT DOSE AND IMAGE QUALITY

It is well known that, because of the statistical nature of the interaction of x-ray photons with the image receptor, the detection of small objects which have low contrast difference with their surroundings is dose dependent. Therefore, in pursuing a policy of patient dose reduction it is important not to reach a point at which relevant clinical information is lost.

A number of theoretical analyses have been carried out to determine the minimum dose required to detect an object of given dimensions and contrast (3). To test these predictions we have designed a phantom consisting of small aluminium discs of different sizes, in the range 5-30 mm diameter and varying thickness up to 2 mm, that can be randomly arranged on a perspex plate and immersed in a tank of water. Contrast may

be adjusted by adding contrast medium to the water. A team of observers will be asked to examine films for "objects" and 50% detection limits will be established at different doses and compared with theory. Preliminary studies show that, for 70 kVp, a contrast $C (=0.4343\gamma(\mu_2-\mu_1)x)$ of about 0.21, a surface dose of approximately 0.13 mGy is required to perceive a 10 mm diameter aluminium disc.

CONCLUSION

Radiography staff have found the procedure for making direct measurements of the patient entrance dose easy and the results very informative. Comparison of results between departments has readily indicated those departments consistently giving higher than recommended doses where priority should be given to reducing doses. Several departments have already reviewed their practices and made changes which have been assessed for their effectiveness in dose reduction by making repeat measurements after the change.

Perception studies have been initiated to determine whether there is a serious risk of loss of image detail for some of the lowest doses reported in the survey.

REFERENCES

1. NRPB/RCR Documents of the NRPB, Volume 1, No.3, 1990. Patient Dose Reduction in Diagnostic Radiology. Published by HMSO, London, U.K.
2. Shrimpton, P.C., Wall, B.F. and Hillier, M.C. Suggested Guideline Doses For Medical Examinations. Proceedings of the 25th Anniversary Symposium of the Society for Radiological Protection, Editor: E.P. Goldfinch. (Bristol: IOPP) 1989.
3. Dance, D.R. Diagnostic Radiology with X-rays. in "The Physics of Medical Imaging". Edited by S. Webb. Medical Science Series, published by Adam Hilger, Bristol, U.K. 1988. pp 22-30.

THE FREQUENCIES AND DOSES OF MEDICAL EXPOSURE IN CHINA*

Zhang Liangan, Zhang Jingyuan, Jia Delin, et al.

Institute of Radiation Medicine, CAMS, Tianjin, 300192

ABSTRACT

The frequencies and patient doses of medical exposure were investigated in China. The sampling surveys of the work covered 15000 hospitals in 24 provinces. In the work, we compile data of 11 million cases. The data were analyzed by computer, and the frequencies, averages of skin and organ dose per examination, and population doses per capita (He, LSD, GSD, SSD) were found.

METHODS

Epidemiological stratified sampling was employed in this research. According to the results of sampling, the frequency of medical exposure was surveyed in more than 15000 hospitals in 24 provinces. Sampling measurements of patient skin dose covered 2000 hospitals in 14 provinces.

Thermoluminescent dosimetry (TLD) was adopted for patient dose monitoring. During monitoring, a TLD detector was attached to each patient to monitor patient skin dose (d). Organ dose (D_T) of each patient was determined by the following equation :

$$D_T = C_T d \quad [1]$$

where C_T is the conversion coefficient of d into D_T. C_T was determined in simulation experiments using an anthropomorphic phantom.

In clinical nuclear medicine, the organ dose of a patient receiving radiopharmaceuticals can be estimated by MIRI method⁽²⁾.

The effective dose equivalent (He), genetically significant annual dose(GSD), annual mean bone marrow dose per capita (CML), leukemia significant annual dose(LSD), and malignancy significant annual dose(SSD) were also calculated in this work.

RESULTS

The frequency of diagnostic X-ray was 145.1 examinations per 1000 population, much higher than that of nuclear medicine or radiation therapy. High annual frequency of diagnostic radiation were noted in chest, abdomen, G.I., and extremities examination, with the annual frequency of chest examination being the highest. The frequency of chest fluoroscopy (the predominant form of chest examination) was about 88.9 cases per 1000 population; 7.5 times that

* This work is a contract project of International Atomic Energy Agency No.4964/R1/RB

of chest radiography (Table 1) .

Table 1. Annual frequencies of medical exposure in China (cases per 1000 population)

Type	Frequency	Type	Frequency
Diagnostic X-ray	146.1 (Total)	Nuclear medicine	0.62 (Total)
Chest		Thyroid scintigraphy	0.086
Fluoroscopy	84.3	Thyroid uptake	0.281
Mass fluoroscopy	26.6	Liver scintigraphy	0.087
Radiography	11.9	Kidney scintigraphy	0.162
Abdomen	12.7	Others	0.066
Alimentary canal	6.0	Radiotherapy	0.09 (Total)
Spine	4.0	Esophageal cancer	0.018
Pelvis	1.3	Pharyngeal cancer	0.023
Extremities	11.6	Breast cancer	0.012
Dental radiography	2.1	Others	0.037
Others	6.8		

The annual frequency of age group 20 to 29 was the highest, but mass examination comprised an important part of the annual frequency for this age group. When mass examination was deducted, the annual frequency peak occurred in age group 30-44, and the differences among various age groups were obvious, with males being exposed more frequently than females in every age group.

The annual frequency of utilization of various nuclides in nuclear medicine were surveyed. The relative frequency for ^{131}I was the highest (about 88%), while that for $^{99\text{m}}\text{Tc}$ was the lowest (less than 1%).

In this work, patient skin dose means the dose to that part of a patient's body surface where a TLD dosimeter was worn. The patient skin dose per G.I. examination was the highest about 61.6 mGy/exam. The doses of lumbar spine examination and cholecystography were higher than that of chest examination(32.6 and 26.8 mGy/exam). As for chest examination, the patient skin dose for fluoroscopy was 10.4 mGy/exam, 10 times that of radiography(Table 2)

Table 2. patient dose per examination in various diagnostic X-ray procedure (mGy/exam)

Organ	Chest		G. I.	Lumbar spine	Abdomen	Pelvis
	Flu.	Rud.				
Skin dose	10.4	1.07	61.6	32.6	8.40	11.0
Testicles	<0.01	<0.01	0.26	0.10	0.02	0.87
Ovary	<0.01	<0.01	1.06	6.86	0.17	5.23
Red marrow	0.27	0.04	6.06	1.82	1.63	1.04
Colon	0.10		8.06		0.02	
Lungs	0.61	0.19	9.29	1.88	0.01	
Stomach	0.19		7.79		0.01	
Effec. dose	0.29	0.07	7.36	2.87	0.13	1.63

The differences in patient skin dose from X-ray machines of various capacities were analyzed. Here, the patient skin dose

from X-ray units of small capacity (<50 mA) were the highest, about 2 times that of big capacity machines(>100 mA).

Organ doses of patients receiving diagnostic X-ray examinations were estimated by reference to the results of patient skin dose measurements and simulation tests. The average organ doses per examination for X-ray procedures are given in Table 2. The gonad dose in lumbar spine examination was the highest, but the doses to other organs were also remarkably high in G.I. examination.

The average administration quantities per examination or treatment are listed in Table 3. Although the same procedure may be used, the annual effective doses per examination may differ greatly when different radiopharmaceuticals are used. For example, in thyroid scintigraphy, the annual effective dose per examination is 93.8 mGy with ^{131}I , and this is 300 times that with $^{99\text{m}}\text{Tc}$.

Table 3. Patient dose in nuclear medicine procedures

Type	Nuclide	Administered quantity (MBq/exam)	Effective dose (mGy/exam)
Brain scintigraphy	$^{99\text{m}}\text{Tc}$	137.7	1.8
Thyroid scintigraphy	^{131}I	5.9	93.8
	$^{99\text{m}}\text{Tc}$	23.2	0.3
Liver scintigraphy	^{198}Au	21.7	21.7
	$^{99\text{m}}\text{Tc}$	96.6	1.2
Thyrotoxicosis	^{131}I	162.2	2596.0
Polycythemia vera	^{32}P	8.7	14.8

The annual dose equivalent per capita were analyzed in the work. The major sources of the organ dose equivalent per capita came from G.I. examination and chest fluoroscopy.

Using the values in Table 2, CMD, GSD, LSD and SSD were estimated (Table 4). Here, age and sex distributions were taken from national statistics data⁽²⁾. The total CMD, He, SSD, LSD and GSD for medical X-ray diagnostic were 73.7, 88.1, 65.7, 69.0 and 9.81 $\mu\text{Sv/a}$ respectively.

Table 4. population dose equivalents per capita for diagnostic radiology ($\mu\text{Sv/a}$)

Type	He	CMD	LSD	GSD	SSD
Chest					
Fluoroscopy	22.4	20.8	20.4	0.46	19.7
Radiography	0.83	0.65	0.62	0.04	0.66
Alimentary canal	45.7	36.6	34.0	1.22	30.1
Cholecystography	0.63	0.48	0.48	0.04	0.63
Lumbar spine	10.7	7.32	8.83	3.90	6.96
Pelvis	2.05	2.05	2.05	3.15	2.05
Abdomen	1.96	1.49	1.49	0.14	1.96
Others	3.83	4.41	3.23	0.88	3.66
Total	88.1	73.7	69.0	9.81	65.7

DISCUSSION

For comparison, the main characteristics of medical exposure in countries with various levels of health care are listed in Table 5. In general, the health care level of a country was determined according to the serving population per physician. So China's health care was below 2. Some features of medical exposure in China, such as annual frequency of diagnostic examination and population per X-ray machine, are at level 2, some features are at level 3 or 4, but the equivalent dose per capita from nuclear medicine are at level 1. This situation was caused by high patient dose in nuclear medicine in China.

Table 5. Main characteristics of medical exposure in countries with various levels of health care*

Item	Level of health care				China
	1	2	3	4	
Popoles per physician	<1000	1000-2999	3000-9999	>9999	1106
Annual frequencies (cases/1000population)					
Diagnostic radiology	760	160	60	30	145.1
Nuclear medicine	18	1.2	0.4	0.2	0.82
Radiation therapy	2.4	0.8	0.1	0.01	0.09
Dental radiology	260	4	0.8		2.13
Dose equivalent per capita (mSv/a)					
Diagnostic radiology					
He	1.0	0.6	0.3		0.10
GSD	0.3	0.06	0.03		0.01
Nuclear medicine					
He	0.06	0.004	0.001	0.0005	0.02
GSD	0.01	0.001	0.0002	0.0001	0.006
Population per X-ray set	4000	20000	80000	170000	18000

* Except for the values of China, other values are based on the reports by UNSCEAR⁽²⁾ and Fred⁽⁴⁾

REFERENCES

1. International Commission on Radiation Units and Measurements, Method of assessment of absorbed dose in clinic uses of radionuclides, ICRU Report 32, Washington, D.C.: ICRU Publication, 1979; 39
2. Population Census Office Under the State Council and Department of Population Statistics, State Statistical Bureau, People's Republic of China, 1982 Population Census of China, Beijing, 1985; 1
3. United Scientific Commission on the Effects of Atomic Radiation Exposure from Medical Uses of Radiation (Report to the General Assembly), New York, 1987; 69
4. Fred A. et al., Analytical modeling of world-wide medical radiation use, Health Physics 1987; 2(52):133

Estimation of Organ Biodistribution of Activities in Human from External Measurement with TLD

T. Nakamura, M. Matsumoto, H. Watabe, M. Itoh and J. Hatazawa

Cyclotron and Radioisotope Center, Tohoku University
Aoba, Aramaki, Aoba-ku, Sendai 980, Japan

ABSTRACT

Biodistribution due to intravenous administration of F-18-fluorodeoxyglucose (FDG) in positron emission tomography (PET) studies was estimated from external measurement with thermo-luminescence dosimeters (TLDs) attached on the body surfaces of normal volunteers. The cumulated activities in nine source organs, brain, heart, lung, liver, kidney, pancreas, spleen, bladder and remainder of the body, were estimated by the unfolding method from the body surface dose measured with the TLDs. Cumulated activities thus obtained well agreed with those obtained with the direct measurements by PET. The TLD method will greatly contribute to internal dosimetry of patients because of its easy-handling.

INTRODUCTION

Internal dosimetry resulting from nuclear medicine is important in comparing the benefit of a procedure with its potential risk. The estimation of internal dose due to intake of radioisotopes has been established by the MIRD method. In the MIRD method, the doses absorbed in target organs are estimated from cumulated activities in source organs. The information on cumulated activities has been obtained for some specific organs necessary for nuclear medicine directly by PET, but is very scarce for other source organs in human. Organ biodistribution of cumulated activities usually has been measured in animals and extended to human, despite of the metabolic difference.

Here in this study, we developed a new method to estimate the biodistribution of radioactivities, which are injected into patient in nuclear medicine procedures from external exposure measurement with TLDs. In this method, a number of TLDs are attached on patient's body surface close to source organs to obtain the information on body surface doses. The organ biodistribution of radioactivities can be obtained from the surface doses by the inverse transform method coupled with the radiation transmission factor calculated with an aid of a mathematical phantom.

This new method has great advantages that cumulated activities in several organs can be obtained easily with a single procedure, and the measurements of

body surface doses are simultaneously done with the PET study, since TLDs are too small to interrupt other medical measurements. The measurements of body surface doses were done in clinical PET studies with F-18-FDG performed at the Cyclotron and Radioisotope Center (CYRIC) of Tohoku University.

MATERIALS AND METHODS

In our TLD method, the absorbed dose on a body surface is given by

$$\begin{aligned}
 C_i &= R_{i,1} X_1 + R_{i,2} X_2 + \dots \\
 &= \sum_j R_{i,j} X_j,
 \end{aligned}
 \tag{1}$$

where C_i is the absorbed dose at i -th TLD position, X_j the integrated activity of j -th source organ during the TLD attachment on the body surface and R_{ij} the absorbed dose at i -th TLD position per unit cumulated activity of j -th source organ. This equation can be expressed as a matrix equation,

$$C = R \cdot X
 \tag{2}$$

The C -vector capere obtained from the TLD measurements and the R -matrix can be calculated by using the MIRD mathematical phantom, so that one can obtain the X -vector by performing the inverse transform of the above matrix equation.

A pair of TLDs of $CaSO_4(Tm)$ were attached at nine points on a body surface just above brain, thyroid, heart, left and right lungs, liver, left kidney, spleen and bladder which were regularly selected in the PET sutdy. Figure 1 shows the TLD positions in the framework of MIRD phantom, together with their Cartesian coordinates and nearby source organs. Eight organs were selected as source organs, i.e., brain, heart, lungs, liver, kidneys, pancreas, spleen and bladder which are already known as organs which accumulate F-18-FDG by Mejia et al. (1) The remainder part of the body was treated as a single source organ in which radioactivity was uniformly distributed. Then in total, nine regions were considered as the source organs in this study. Nine values of TLD doses, C_i , determine nine values of organ activities, X_j , by unfolding Eq. (1).

Calculations of the R component, R_{ij} , are done by the VADMAP code (2) based on the point kernel method with the MIRD mathematical phantom composed of water. The lung is assumed to be composed of water whose density is 0.3. From the measured body-surface doses at nine points, C_i , and the calculated response of body-surface dose at each position per unit

cumulated activities. R_{ij} , cumulated activities in nine source organs can be unfolded by the slightly modified SAND-II code (3) based on the successive iterative method. This unfolding is practiced under the constraint condition that the sum of cumulated activity in each source organ must be equal to the total accumulation of administered activity as follows,

$$\begin{aligned} X_{\text{total}} &= X_1 + X_2 + X_3 + \dots \\ &= \int_0^t A_0 \exp(-\lambda t) dt, \end{aligned} \quad (3)$$

where A_0 is the injected activity, λ the decay constant of F-18 and t the measuring time period.

RESULTS AND DISCUSSION

The TLD measurements of body-surface dose were done for 7 normal volunteers. Five volunteers were measured for 1 hour after administration of F-18-FDG and two patients were measured for 2 hours after that. The measured data of C_i were converted to the cumulated activities in source organs by the modified SAND-II unfolding code. As the TLD measurements could be done only during the course of clinical PET procedure, the estimation of the cumulated activities was also possible only for that period. The contribution of residual cumulated activities after the TLD measurement can be estimated, assuming that a biological clearance is negligible and only physical decay dominates.

Figure 2 shows the correlation of the present results of cumulated activities given by the TLD method and those by the direct PET measurements. (1) Generally speaking, good correlation can be seen between our TLD method and the PET reference values except for kidney and brain. The discrepancy on the brain activity may be due to inhomogeneous distribution of activity in the brain, and that on the kidney activity may come from a large difference of physique between the MIRDO phantom and each individual, since the distance from the seventh TLD position to the kidney was largest among all as seen in Fig. 1.

It can be concluded that the new method to estimate the organ biodistribution in human from the surface dose measured with TLDs gives sufficiently good results considering experimental errors. This TLD method has great advantages that cumulated activities in numbers of human organs can be estimated very easily at once, and that the TLD measurements can be done simultaneously with medical study without interrupting it.

References

1. Mejia, A.A., Nakamura, T., Itoh, M., Hatazawa, J., Matsumoto, M. and Watanuki, S., 1991, Estimation of absorbed doses in human due to intravenous administration of F-18-fluorodeoxyglucose in PET studies, *J. Nucl. Med.*, 32, 699-706.
2. Yamaguchi, Y., Togawa, O. and Honma T., The VADMAP code to calculate the SAF of photon, 1987, JAERI M 87-186, Japan Atomic Energy Research Institute.
3. McElroy, W.N., Berg, S., Crockett, T. and Hawkins, R.G., A computer automated iterative method for neutron flux spectra determination by foil activation, 1967, AFWL-TR-67-41, Air Force Weapons Laboratory.

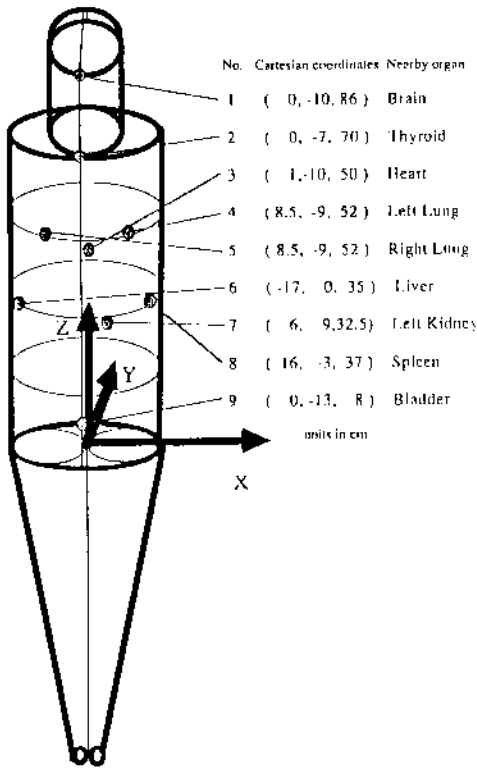

Fig. 1 Detection positions of body surface dose with TLDs which are adjusted to MIRD mathematical phantom. The figure also indicates their Cartesian coordinates and nearby source organs

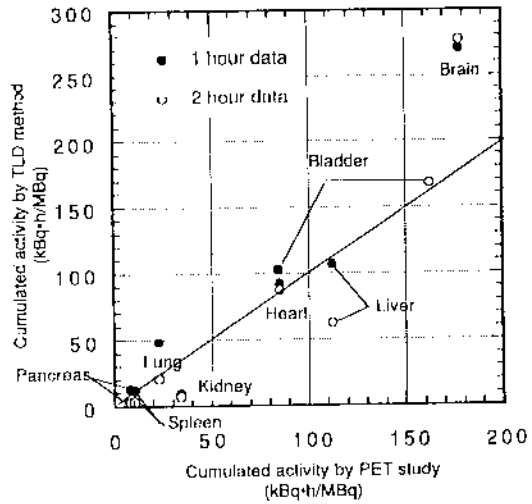

Fig. 2 Correlation between cumulated activities of source organs in kBq.h per MBq F-18-FDG injection estimated from the TLD method and those from the PET method as a reference.

DOSE TO SOME SELECTED ORGANS FROM INTAKE OF RADIONUCLIDES IN INDIAN POPULATION

* * * * *
S C Jain , M M Gupta , A Nagaratnam & A R Reddy

- * Institute of Nuclear Medicine & Allied Sciences,
Lucknow Road, Delhi - 110 054, India
- ** Defence Metallurgical Research Laboratory,
Kanchanbagh, Hyderabad - 500 258, India
- *** Defence Laboratory, Ratanada Palace,
Jodhpur - 342 001, India

ABSTRACT

The dose to some selected organs has been estimated from intake of radionuclides taking into consideration the organ weights in Indian Man and Child of various age groups using dose coefficients as given by ICRP-56. The effective dose computed as per new tissue weighting factors given by ICRP-60 increased by 40-75% from the old values from the ingestion of ^{131}I and ^{144}Ce . However, only marginal change was found in the case of ^{137}Cs . In Indian Population, there was a further increase upto 20%.

INTRODUCTION

ICRP-56 (1990) has computed age-dependent dose coefficients (also called dose equivalents) for various organs and tissues to members of the public from intake of most radiologically significant radionuclides that might be released to the environment due to various human activities. These dose coefficients have been estimated for ICRP Reference Man, Child and Infant. However, Indian population differs significantly from their ICRP counterpart as regards anatomical and physiological characteristics as shown by Venkatraman et al (1963) and Jain et al (1991, 1992). In the present study, efforts are made to estimate dose to some selected organs for different ages taking into account dose transformation factors as estimated by the method suggested by Yamaguchi (1978). Further the revised effective dose was computed using revised tissue weighting factors as recommended by ICRP-60 (1991) from intake of some radionuclides and compared the same with the corresponding estimated values for Indian Population.

METHODOLOGY

The weight of five organs, namely, brain, kidney, liver, lungs and spleen was obtained from extended study of 2000 postmortem records in Indian population (Jain et al, 1992) of various age groups. These organ weights being

different from ICRP counterpart and hence the dose coefficients will be different in these subjects than their ICRP counterpart. The dose coefficients in Indian population of various age groups namely 1yr, 5yr, 10yr, 15yr and adult was computed by computing the dose transformation factors (DTF) for different organs using the method suggested by Yamaguchi (1978). These transformation factors are multiplied by the corresponding organ dose coefficients to give the revised dose estimates to the organs. In the present study, only three radionuclides ^{131}I , ^{137}Cs and ^{144}Ce were considered. The transformation factors for various organs were worked out for the principal gamma energy emitted by these radionuclides. The effective dose, E was also computed for ingestion of these radionuclides utilising the new tissue weighting factors as given by ICRP-60. Thymus is taken as surrogate to oesophagus and colon is considered to be the same as ULI (Phipps et al, 1981). However, the dose coefficients for all the remainder organs were not available in ICRP-56 and it is considered that the dose to these organs is the same as the average dose to 8 remainder organs for which information is available. Further the effective dose was also computed for Indians of different age groups utilising the transformation factors as calculated for selected organs above. For the other organs, if the weight of the organ is less than 20 g, DTF is taken as 1 and for the others, DTF has been computed considering the organ masses to be proportional to the body weight.

RESULTS & DISCUSSION

Table 1 gives the mean DTF for various organs in the Indian population for the photon energy 133-662 keV, the variation being negligible for different gamma energies considered.

Table 1. Mean dose transformation factors

Age	Brain	Kidney	Liver	Lung	Spleen	Others <20 g
1 yr	1.01	1.05	0.88	0.82	0.82	1.09
5 yr	1.12	1.12	0.96	0.82	0.83	1.12
10 yr	1.08	1.14	1.00	0.93	0.90	1.17
15 yr	1.09	1.16	1.12	0.89	0.98	1.20
Adult	1.06	1.25	1.21	1.01	1.09	1.16

Table 2 gives the effective dose (E_1) as given by ICRP-56, the revised value of ICRP-56 (E_2) and the revised estimated value of E_2 for Indian population (E_3) from the ingestion of ^{131}I , ^{137}Cs and ^{144}Ce . The revised effective dose, E_2 to ICRP Reference population was found to be increased by 64-75 % for ^{131}I and did not differ in Indian population as more than 99 % contribution to effective

dose comes from dose to thyroid, whose weight did not differ in Indians. In case of ^{137}Cs , E_2 was found to differ marginally from old values due to near uniform distribution of the radionuclide in the body. In Indian population, E_3 values were marginally higher than for ICRP counterpart due to increased organ doses proportional to change in DTF's. However, in case of ^{144}Ce , E_2 were found higher by 39-46 % than old values and increased further in Indian population for the reasons alike ^{137}Cs .

Table 2. Effective dose from ingested radionuclides

Effective dose(Sv/Bq)	Age at intake				
	1 yr	5 yr	10 yr	15 yr	Adult
^{131}I					
E_1	1.1E-7	6.3E-8	3.2E-8	2.1E-8	1.3E-8
E_2	1.8E-7	1.1E-7	5.5E-8	3.5E-8	2.2E-8
E_3	1.8E-7	1.1E-7	5.5E-8	3.5E-8	2.2E-8
^{137}Cs					
E_1	1.1E-8	9.0E-9	9.8E-9	1.4E-8	1.3E-8
E_2	1.1E-8	8.9E-9	9.7E-9	1.3E-8	1.3E-8
E_3	1.1E-8	9.2E-9	1.0E-8	1.5E-8	1.5E-8
^{144}Ce					
E_1	4.3E-8	2.1E-8	1.3E-8	7.2E-9	5.8E-9
E_2	6.2E-8	3.0E-8	1.9E-8	1.0E-8	8.4E-9
E_3	6.8E-8	3.4E-8	2.2E-8	1.2E-8	9.7E-9

CONCLUSION

The revised effective dose to the population from the ingestion of ^{131}I and ^{144}Ce was found to be increased by 40-75 % for various age groups. However, a marginal change was noted for ^{137}Cs . In Indian population, there was a further increase (upto 20 %) from the revised values.

REFERENCES

1. ICRP (1990) Age-dependent Doses to Members of the Public from Intake of Radionuclides. Part I. ICRP Publication 56, Pergamon, Oxford.
2. Venkataraman K, Somasundaram S and Soman S D (1963) An Evaluation of Radiation Protection Standards for Indian Conditions, Health Phys. 9, 647-652.

3. Jain S C, Mehta S C, Reddy A R and Nagaratnam A (1991) Dose Transformation Factors for Indian Physiques of different Age Groups, Proc. V Int. Radiopharmaceutical Dosimetry Symposium (In Press).
4. Jain S C, Mehta S C, Dogra T D, Chandrashekhar N, Reddy A R and Nagaratnam A (1992) Organ Weights in Autopsy cases from an Urban Apex Hospital. Ind. J. Med. Res., (In Press).
5. Yamaguchi, H (1978) Estimation of Internal Dose for various Physiques using MIRD Adult Absorbed Fractions. Acta Radiolog. Oncol. 17, 429-439.
6. ICRP (1991) 1990 Recommendations of the International Commission on Radiological Protection, ICRP Publication 60, Pergamon, Oxford.
7. Phipps A W, Kendall G M, Fell T P and Stather J W (1991) Revised Estimates of Dose from Internal Emitters and Implications for ALI's, Radiat. Prot. Bull. 123, 9-13.

THE EFFECT OF CHANGE IN TISSUE WEIGHTING FACTORS ON EFFECTIVE DOSE COMPUTATION DUE TO CERTAIN NEW RADIOPHARMACEUTICALS IN INDIAN PATIENTS

* * *
M M Gupta , S C Jain and A Nagaratnam

- * Institute of Nuclear Medicine & Allied Sciences,
Lucknow Road, Delhi - 110 054, INDIA
** Defence Metallurgical Research Laboratory,
Kanchanbagh, Hyderabad - 500 0258, INDIA

ABSTRACT

Effective dose has been calculated for three technetium-99m labelled agents used for CBF studies using W_T values recommended by ICRP-1977 and ICRP-1991. The estimated values of effective doses are lower than the earlier one by 10 %. For an average Indian, administration of the same activity results in 8-12 % higher effective dose. It is suggested that amount of activity to be administered to a patient may be normalised to his/her weight.

INTRODUCTION

In India, the levels of activity used in the department of nuclear medicine for diagnostic purposes, have risen dramatically, mostly due to availability of a large variety of radiopharmaceuticals. A necessity has been felt in the department to carry out dosimetric investigations of some of the new radio-tracer agents that are used/are likely to be used for regional cerebral blood flow studies. These investigations are carried out using positron emission tomography (PET) that can provide quantitative images of tracer distribution with high spatial resolution and are able to employ radiotracers that participate in distinct and well defined biochemical/physiological processes. Despite of the recent developments in instrumentation and oxygen-15 dispensing unit, due to high cost, PET investigations may take considerable time to get established at least in developing countries. SPECT and employing technetium-99m labelled compounds that are more economical and are more widely available, is considered to be a system of choice for most of such studies in the country. Radiation dosimetry of such 'diagnostic probes' has become necessary due to: (i) the recommendations of International Commission on Radiological Protection (ICRP-1991) that have brought about significant changes in the methodology of effective dose (that indicates the radiation risk to which the patient is exposed as a result of a particular radiodiagnostic investigation) computation particularly in assigning new set of values to tissue weighting factors (that represent the relative radiation sensitivity of an organ or tissue) and (ii) the prospect that administration of the same amount of radio-tracer agent to a Reference Man (ICRP-1975) and to an average Indian patient may give rise to different effective doses (due to the difference in anatomical characteristics of the latter).

MATERIALS AND METHODS

Intensive efforts are being devoted to design new radio-tracers that will cross the intact blood brain barrier and are capable of measuring regional cerebral blood flow. At present, three such radiopharmaceuticals that have significant potentiality are: technetium-99m hexamethylpropylene amine oxime ($^{99m}\text{Tc-d,1-HMPAO}$), technetium-99m ethylcysteinate dimer ($^{99m}\text{Tc-L,L-ECD}$) and $^{99m}\text{Tc-MRP 20}$ or one of its derivatives, marketed by Amersham, DuPont and Medgenix respectively. These compounds are retained by brain to the similar extent and diffusion rather than metabolism is considered to be the rate limiting step. Table 1 gives the effective dose data of these agents considering the values of tissue weighting factor, 'W_T', as recommended by ICRP-1991. For comparison, the effective doses have also been computed taking into consideration 'W_T' values recommended earlier (ICRP, 1977).

Table 1. Effective dose (mSv) due to the administration of 740 MBq of the technetium labelled agents for rCBF studies considering 'W_T' values recommended by ICRP (1977) and ICRP (1991)

Radiopharmaceutical	Effective Dose	
	using 'W _T ' of ICRP-1977	using 'W _T ' of ICRP-1991
$^{99m}\text{Tc-d,1-HMPAO}$ (Neirinekx et al 1989)	6.02	5.48
$^{99m}\text{Tc-L,L-ECD}$ (Holman et al 1989)	3.64	2.83
$^{99m}\text{Tc-MRP 20}$ ** (Bossuyt et al 1990)	4.12	4.16

**In case of $^{99m}\text{Tc-MRP 20}$, the biodistribution data is still incomplete and as such the effective dose values are very approximate only.

For calculating the effective dose, a procedure that is slightly different from that of Smith (1990) has been adopted and has been outlined in another paper (Gupta and Nagaratnam).

The effective dose calculations have been carried out keeping in mind the anatomical, chemical and physiological characteristics of Reference Man (ICRP-1975). It has been reported that an average Indian differs significantly from the Reference Man (Venkataraman et al, 1966). Data on weight and

size of the body as well as that of the specific organ masses have also been compiled from postmortem records of 2000 cases (Jain et al, in press). Employing this data and computing Dose Transformation Factors (Yamaguchi, 1978) for Indian physiques, effective dose estimation due to the administration of same quantity of radiopharmaceutical has been carried out for an Indian adult and shown in Table 2.

Table 2. Effective dose (mSv/740 MBq) due to technetium-99m labelled agent to a Reference Man and to an average Indian adult using recent 'W_T' values

Radiopharmaceutical	Effective Dose	
	Reference Man	Average Indian Man
^{99m} Tc-d,l-HMPAO	5.48	6.02
^{99m} Tc-L,L-ECD	2.83	3.30
^{99m} Tc-MRP 20	4.16	4.86

RESULTS & DISCUSSION

All the three technetium-99m labelled agents are poorly retained by brain. The clearance from blood and excretion into urine are faster for ^{99m}Tc-ECD. Consequently, dosimetrically the compound is more favourable especially with respect to liver, kidney and intestine. This faster clearance from blood results also in brain images with enhanced contrast. The effective dose to a patient is lower for ^{99m}Tc-ECD. The recent change in 'W_T' values lowers down the estimated effective doses by about 10 % due to all the three compounds. In Indian subjects, administration of similar activities causes 9-12 % higher effective dose mostly due to the difference in their organ weights. Therefore, perhaps, a more rational approach in deciding the amount of radiopharmaceutical that is to be administered may be, to take cognizance of the patient weight.

REFERENCES

1. Bossuyt A, Pirotte R, Chirico A et al (1990) Whole body dosimetry of Tc-99m-MRP 20: the results of a phase I clinical trial. Eur J Nucl Med 16, 432.
2. Holman B L, Hellman R S, Goldsmith S J et al (1989) Biodistribution, dosimetry and clinical evaluation of technetium-99m ethyl cysteinate dimer in normal subjects and in patients with chronic cerebral infarction. J Nucl

Med 30, 1018-1024.

3. ICRP (1975) Report of the Task Group on Reference Man, ICRP Publication 23, Pergamon Press, Oxford.
4. ICRP (1977) Recommendations of the International Commission on Radiological Protection, ICRP Publication 26, Pergamon Press, Oxford.
5. ICRP (1991) 1990 Recommendations of the International Commission on Radiological Protection, ICRP Publication 60, Pergamon Press, Oxford.
6. Jain S C, Mehta S C, Dogra T D et al (in press) Organ Weights in Autopsy cases from an Apex Hospital, Ind J Med Res.
7. Neirinckx R D, Canning L R, Piper et al (1987) Technetium-99m d, 1-HMPAO: a new radiopharmaceutical for SPECT imaging of regional blood perfusion, J Nucl Med 28, 191-202.
8. Smith T (1990) On an alternative method of estimating effective dose equivalent, Eur J Nucl Med 16, 53-54.
9. Venkataraman K, Raghunath V M, Sanathnam K and Somasundram S (1966) Physiological Norms in Indian adults, Health Phys 12, 572-574.
10. Yamaguchi H (1978) Estimation of internal dose for various physiques using MIRD adult absorbed fractions, Acta Radiol Oncol 17, 929-939.

EFFECT OF NEW ICRP RECOMMENDATIONS ON THE EFFECTIVE DOSE
OF SOME NEW RADIOPHARMACEUTICALS

* **
M M GUPTA and A NAGARATNAM

* Head, Health Physics Division, Institute of Nuclear Medicine
& Allied Sciences, Lucknow Road, Delhi-110054, INDIA

** Emeritus Scientist, Defence Metallurgical Research
Laboratory, P.O. Kanchanbagh, Hyderabad-500258, INDIA

ABSTRACT

ICRP (1991) has recommended new values to tissue weighting factor W_T . The effect of changes in ' W_T ' values on effective dose 'E' for two technetium-99m based agents used for myocardial perfusion studies, have been investigated. Due to different biological behavior, the effective dose due to one compound is higher by 12% than the other for the same administered activity. Using the new values of W_T , the effective doses are found to be lower for technetium based agents in comparison to $^{201}\text{TlCl}$.

INTRODUCTION

The concept of effective dose equivalent 'H_E' (now effective dose E) introduced by the International Commission on Radiological Protection (ICRP-1977) for radiation workers, has been successfully applied for patients undergoing radiodiagnostic investigations. In nuclear medicine, the concept is utilised to indicate approximate risk to which the patient is exposed as a result of the investigation and comparing this risk with the possible diagnostic benefits. The effective dose is represented by $E = \sum W_T H_T$ where H_T is the mean absorbed dose in the organ or tissue 'T' (for the emission of most of the nuclides used in diagnostic nuclear medicine mean absorbed dose and equivalent dose are similar) and W_T is the tissue weighting factor representing the relative radiation sensitivity of organ or tissue 'T'. Using the general equation of Coffey and Watson (1979) for biodistribution of the radionuclides in the body and methodology of absorbed dose estimation by Snyder et al (1975), absorbed dose and subsequently using the tissue weighting factors recommended by ICRP(1977), effective dose due to a large number of radiopharmaceutical preparations were compiled (ICRP-1987).

New biological information related to the detriment associated with radiation exposure, is now available. That has necessitated the revision of ICRP recommendations made earlier. The new ICRP recommendations (1991) have brought about significant changes in the methodology of computation of effective dose, particularly regarding the numerical values of ' W_T ' assigned to different tissues or organs. These developments have made it necessary to examine the effect of recent ICRP recommendations on the computation of effective dose due to some new radiopharmaceuticals and comparing the same with conventionally used radionuclide preparations. The

discussion is restricted to pharmaceuticals used for myocardial perfusion studies.

MATERIALS AND METHODS

Nuclear cardiology has helped to predict and to assess the effect of revascularisation procedures, to avoid needless angiography and to improve the diagnosis of coronary artery diseases. Recently two technetium based radiopharmaceuticals have become available for myocardial perfusion studies - Technetium-99m [MIBI]₆ where MIBI is 2-methoxy isobutyl isonitrile and Tc 99m - Teboroxime marketed by Du Pont Pharma and Squibb Diagnostics respectively. These preparations have very different pharmacokinetics in the body probably because of their charges and different oxidation states of technetium. Table 1 gives the effective dose received due to the administration of 1110 MBq of the radiopharmaceuticals and assuming 2 hour urinary bladder voiding intervals, considering tissue weighting factors recommended by ICRP (1977) and ICRP (1991).

Table 1. Effective Dose (mSv) due to administration of 1110 MBq of technetium-99m MIBI and Teboroxime considering W_T values recommended by ICRP (1971) and ICRP (1991)

Radiopharmaceutical	Effective dose	
	W_T of ICRP-1977	W_T of ICRP-1991
Technetium-99m MIBI	13.95	10.17
Technetium-99m Teboroxime	14.21	11.76

Based on data of Stabin (1990) and McSherry (1991)

In absence of complete data on mean absorbed doses to all organs or tissues of interest, the following procedure for approximation has been adopted:

- (i) Mean absorbed dose to LLI wall has been used to approximate the dose to colon (Phipps et al 1991).
- (ii) Whenever the mean absorbed dose to an organ or tissue and the explicit value of W_T assigned to it are available, the contribution of the organ or tissue to the effective dose to the body has been computed as per standard procedures recommended by ICRP-1977 and ICRP-1991.
- (iii) In other cases after carrying out the procedure (ii), the remaining residual value of W_T is equally divided between the remaining organs or tissues of group 1 and group 2 as specified by ICRP (1987). In carrying out these calculations, the provisions of ICRP (1991) recommendations have been kept in mind. This is a

slightly modified approach of that suggested by Smith (1990).

Calculating in the similar fashion, the effective dose due to $^{201}\text{TlCl}$ has also been computed and compared with these technetium based agents in Table 2.

Table 2. Comparison of effective dose due to three radiopharmaceuticals used currently for cardiac perfusion studies

Radiopharmaceuticals	Effective Dose (as per recent W_T values)
MIBI	6.78 mSv/740 MBq
Teboroxime	7.80 mSv/740 MBq
$^{201}\text{TlCl}$	8.70 mSv/111 MBq

Discussion and Conclusion

MIBI is cleared more rapidly from the blood and liver than Teboroxime. Therefore the radiation dose of the BATO complex is higher to the liver but lower to the intestine and kidney and its effective dose is also higher than MIBI by about 12%. However, the effective dose of both the technetium labelled agents is favourable compared with that of $^{201}\text{TlCl}$.

REFERENCES:

1. Coffey J L, Watson E E (1979) Calculating dose from remaining body activity. A comparison of two methods. Med. Phys. 6: 307-308
2. ICRP (1977) Recommendations of the International Commission on Radiological Protection, ICRP Publication 26, Pergamon, Oxford.
3. ICRP (1987) Protection of the patients in Nuclear Medicine, ICRP Publication 52, Pergamon, Oxford.
4. ICRP (1991) 1990 Recommendations of the International Commission on Radiological Protection, ICRP Publication 60, Pergamon, Oxford.
5. McSherry B A (1991) Technetium -99m-Teboroxime: A new agent for myocardical perfusion imaging. J. Nucl. Med. Tech. 19: 22-26.
6. Phipps A W, Kendall G M, Fell T P and Stather J W (1991) Revised estimates of dose from internal emitters and implications for ALI's Radiat. Prot. Bull. 123: 9-13.

7. Smith T (1990) On an alternative method of estimating effective dose equivalent. Eur. J. Nucl. Med. 16: 53-54.
8. Stabin M (1990) Oak Ridge Associated Universities, Oak Ridge, TN 37831 (615) 576-3449.
9. Snyder W S, Ford M R, Warner G G and Watson S B (1975) 'S' Absorbed dose per unit cumulative activity for selected radionuclides and organs. MIRDO Pamphlet No. 11.

DISCHARGE LEVEL OF PATIENTS RECEIVED THERAPEUTIC AMOUNT OF RADIO-ACTIVE IODINE 131

S. Koga, K Koshida, *T. Orito, *A. Takeuchi and *S. Suzuki
Department of Radiology, Fujita Health University School of Medicine

*Department of Radiological Technology, Fujita Health University School of Health Sciences, Toyoake, Japan.

INTRODUCTION

Iodine 131 utilized for treatment of thyroïdal disease is the only Radionuclide (RN) presently used for therapy in Japan. The patient administered therapeutic amount of I-131 must be accommodated in a RN ward. However, there are only small number of data which can be used in investigating the criteria for permitting the patient to leave the RN ward. In 1976, ICRP suggested in Publication 25 the maximum allowable activities at discharge of patients following treatment with RN. 15mCi of I-131 were thought the level not likely to arise unacceptable hazards in the patient's home if the patient did not come into close contact with young children. This paper describes levels for discharge from hospital of patients treated with I-131. The level was determined by comparing the possible exposure dose to those individuals whom the patient are in daily contact with the annual dose limit for the public.

MATERIAL and METHOD

We evaluated external radiation dose of each family of the patient based on the data on spatial dose distribution around the three radioactive patients, and data on the distance between the patient and individuals, length of the time spent at each distance, and each individual's age which were recorded and analyzed on 53 subjects from 14 ordinary Japanese families.

Spatial dose distribution curves based on the measurement of clinical cases were studied around the patients treated with I-131 for thyroid carcinoma and they were administered 3.7, 3.26 and 3.33GBq of I-131, respectively. The measurement of the spatial dose distribution was performed using an ionization survey meter at the point every 30cm in the flat surface 80cm over the floor surface. Linear scan ningo were also carried out using Medical Universal Human

Counter in order to know the distribution of RN with in the patient's body.

14 housewives living in Toyoake City were taken as the models of the patients with hyperthyroidism, because the considerable proportion to the patient with hyperthyroidism was female of those ages. The investigation was carried out by means of the interviews and questionnaires which were performed by public health nurses of the Department of Public Hygiene Nursery Services, Fujita Health University Hospital. They visited each home of the subjects more than three times and taught how to enter in the questionnaires. After the withdrawal of those questionnaires position and time in the proximity of the subjects and their family members were analysed.

RESULT and DISCUSSION

1) Spatial dose distribution curve around the patient had been reported by Orito, one of the authors.

2) Distance between the subjects and their family members and time spent at those distances

Table 1 (a), (b)1, and (b)2 show the distances between the subjects and their family members and time spent at those distances. more than 180cm were treated as infinities. Husband of those subject were all workers at outside of their home, so that their chance being close in position with their wives was limited to the period from the night to the morning. While for the children, the shorter the distance and the longer the time spending with their mothers. Levels for discharge to home of patients who received therapeutic dose of I-131 based on external radiation dose.

Fig.1 shows the residual radioactivity as a function of the distance from the patient in the bed room. The activity gives her husband dose equivalent of 1mSv. Curve (a), (b) and (c) are residual radioactivity assuming that with effective half lives of 3.9, 5.9 and 7.2days respectively.

Fig 2 shows the residual radioactivity as a function of the age of the patient's child. The activity gives her child dose equivalent of 1mSv, Curve (a), (b) and (c) are the residual radioactivity assuming that with effective half lives of 3.9, 5.9 and 7.2 days respectively.

The allowable activity at discharge should be decided to ensure the

patient family not to exceed the dose limit recommended from ICRP to the member of the public.

If it is permissible to use a subsidiary dose limit of 1mSv in a year, calculated discharge levels from hospital to home are as

Table 1 Distance between the subjects and their family members and time spent at those distances

(a) Time interval in each time division

Time interval in the case of	Time division						
	T1	T2	T3	T4	T5	T6	
Husband	6:45-7:45	7:45-14:00	14:00-19:30	19:30-20:00	20:00- 0:15	0:15-6:45	
Children at age	0-2	6:45-8:30	8:30-14:00	14:30-18:30	18:30-19:00	19:00-20:30	20:30-6:45
	3-5	7:15-8:30	8:30-14:00	14:00-18:30	18:30-19:00	19:00-20:30	20:30-7:15
	6	6:15-7:45	7:45-13:30	13:30-18:30	18:30-19:00	19:00-21:00	21:00-6:15
	11	6:15-7:45	7:45-16:00	16:00-18:30	18:30-19:00	19:00-21:00	21:00-6:15
	19-21	6:15-7:45	7:45-18:00	18:00-18:30	18:30-19:00	19:00-21:00	21:00-6:15
25, 26	6:15-7:45	7:45-14:00	14:00-19:30	19:30-20:00	20:00- 0:15	0:15-6:15	

(b) Average distance between the patient and her family in each time division

1. Average distance between the patient and her husband

Pattern	Time division					
	T1	T2	T3	T4	T5	T6
(A)	10cm	∞	∞	180cm	135cm	10cm
(B)	135cm	∞	∞	135cm	45cm	45cm
(C)	180cm	∞	∞	135cm	135cm	90cm
(D)	180cm	∞	∞	180cm	135cm	135cm
(E)	180cm	∞	∞	135cm	135cm	180cm

2. Average distance between the patient and her child

Age	Time division					
	T1	T2	T3	T4	T5	T6
0	45cm	135cm	45cm	10cm	10cm	90cm
1	10cm	180cm	∞	180cm	90cm	90cm
2	135cm	45cm	90cm	135cm	135cm	90cm
3	180cm	180cm	180cm	180cm	180cm	90cm
4	180cm	∞	∞	180cm	180cm	90cm
5	180cm	∞	135cm	135cm	135cm	90cm
6	135cm	∞	180cm	135cm	90cm	∞
11	45cm	∞	∞	45cm	135cm	135cm
19	135cm	∞	90cm	90cm	90cm	∞
20	90cm	∞	∞	∞	90cm	∞
21	45cm	∞	∞	45cm	∞	∞
25	45cm	∞	∞	90cm	∞	∞
26	90cm	∞	∞	∞	180cm	∞

follows. Maximum residual activity should be less than 0.1 GBq, if

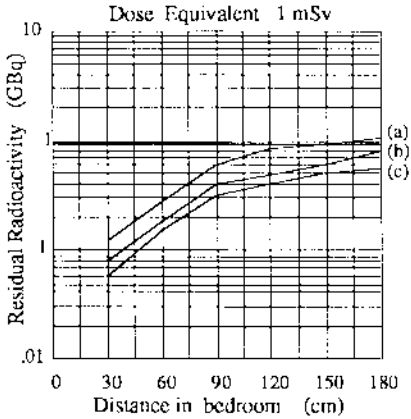

Fig 1 The residual radioactivity as a function of the distance from the patient in the bedroom.

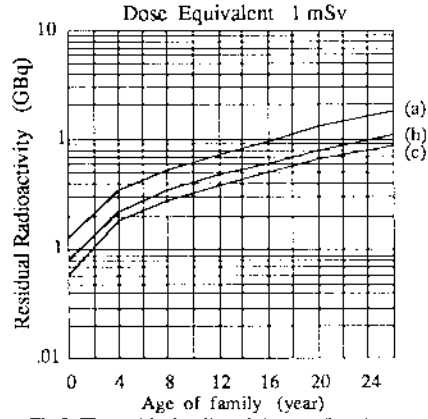

Fig 2 The residual radioactivity as a function of the age of patient's child.

the distance from the patient in bed room is 50cm or more and there is no children younger than one year in the home. No restriction is necessary for the patient with residual activity of 0.05 GBq or less.

CONCLUSION

This paper describes levels for discharge from hospital of patients treated with I-131. The level was determined by comparing the possible exposure dose to those individuals whom the patients are in daily contact with the annual dose limit for the public. The external radiation dose was calculated by using the data on the distance between the patient and individuals, length of the time spent at each distance, and each individual's age. The following levels were obtained.

For the patient to be discharged from the hospital, the maximum residual radioactivity should be less than 0.1GBq if the distance from the patient in bedroom is 50cm or more and the age of her children are all over one year. No restriction is needed for the patient with residual activity of 0.05GBq.

(mode, cinétique, niveau éventuellement en fonction de la saison ou du stade végétatif) des principaux contaminants (iode, césium, strontium, ...) dans le produit lui-même et dans ses principaux dérivés. Ces fiches doivent également proposer aux producteurs des mesures préventives et aux industriels chargés de la transformation des consignes d'exploitation. Un tout premier ensemble de fiches techniques a été rassemblé par la Fédération Nationale des Syndicats d'Exploitants Agricoles (FNSEA) et par l'IPSN.

Les études générales de radioécologie ont fourni de nombreuses valeurs de coefficients de transfert ; le programme RESSAC a permis d'obtenir des données sur les facteurs d'interception des végétaux lors d'un dépôt et poursuit l'étude des facteurs de transfert avec un terme-source représentatif d'un accident sur réacteur et des lysimètres contenant des blocs de sol prélevés autour de sites nucléaires en exploitation.

Une première utilisation des bases de données et des fiches techniques est l'établissement, par les experts, de cartes situant les points où prioritairement des prélèvements d'échantillons seraient à faire.

3 - MOYENS ET ORGANISATION EN CAS DE CRISE

Au début de la phase post-accidentelle, en un premier temps sur la base des prévisions de retombées puis avec les résultats des toutes premières mesures, il faut bâtir un plan de caractérisation de la contamination dont les résultats doivent permettre de définir une stratégie d'action. Ceci se fait dans le cadre d'une organisation de crise qui regroupe auprès du Préfet les représentants des principaux services publics.

3.1 - Plan de caractérisation de la contamination

Pour bâtir ce plan, les bases de données et les fiches techniques précédemment décrites sont nécessaires mais non suffisantes. Il faut une grande implication des experts de l'agriculture, tant au niveau national que local, auprès du Préfet. En effet ce sont ces experts qui connaissent le milieu, l'état réel des productions et leur importance socio-économique compte tenu de la saison et de la région concernées. Ils seront à même de définir, par produit, les meilleurs emplacements pour effectuer les prélèvements et également, ce qui est très important, de faciliter le contact avec la population rurale.

3.2 - Recueil, validation, synthèse et exploitation des résultats de mesure

Les prélèvements et mesures, réalisés avec des protocoles pré-établis par des équipes appartenant à des services différents ont besoin d'être validés et synthétisés. Ici encore, le rôle des experts de la filière agro-alimentaire est fondamental ; ils doivent s'assurer de la suffisance et de la cohérence des résultats puis de la pertinence de la présentation. Cette présentation doit se faire, autant que possible, sous forme cartographique, transmissible, via les réseaux de télécommunication, vers les différentes cellules de crise (niveau local et national). C'est à partir de cette synthèse que les experts (du programme RESSAC pour l'IPSN, de la filière agro-alimentaire pour la cellule du Préfet) proposeront une stratégie d'action avec un choix de contre-mesures adaptées. Des systèmes experts commencent à être opérationnels et pourraient servir de base de départ aux réflexions des experts présents lors de la crise.

4 - INFORMATION, FORMATION ET EXERCICES

Les experts potentiels du Préfet en cas de crise (services agricoles, vétérinaires, des eaux, ...) sont en général peu impliqués normalement dans les problèmes de contamination radioactive. Il est donc nécessaire d'informer, de sensibiliser puis de former et d'entraîner ces experts de façon régulière.

Le milieu agricole lui-même doit également être informé si l'on veut qu'il réagisse correctement à ce qui peut arriver. C'est dans ce but que l'IPSN a réalisé avec la FNSEA un document de caractère pédagogique qui explique comment réagir en cas d'accident.

Les exercices de simulation permettent aux représentants des pouvoirs publics et aux experts de s'entraîner. Depuis 1987, trois exercices nationaux portant sur la phase post-accidentelle ont été réalisés. La simulation, pour être efficace, exige une longue préparation qui est d'ailleurs souvent l'occasion de vérifier les données disponibles et de sensibiliser les experts, surtout au niveau local, qui sont amenés à participer. Pour pouvoir simuler les résultats de mesure dans l'environnement, l'IPSN a mis au point le logiciel GEREM, déjà utilisé sur des micro-ordinateurs portables lors de précédents exercices. Ce logiciel pourrait, entre les exercices nationaux qui ne peuvent pas être très fréquents, servir à entraîner les acteurs de la crise en fournissant, à la demande, des "résultats" de mesure qu'il faudrait interpréter et synthétiser.

5 - CONCLUSION

L'accident de Tchernobyl a sensibilisé les pouvoirs publics et l'opinion aux conséquences d'une contamination radioactive de l'environnement. En France, le programme RESSAC fournit un ensemble de données sur les transferts de contamination et les modes de réhabilitation des sols. Parallèlement les pouvoirs publics poursuivent la mise au point du Plan d'action Post-Accidentel (PPA) et organisent des exercices nationaux de simulation de la phase post-accidentelle d'un accident sur réacteur.

Il apparaît clairement que le rôle des experts de l'IPSN et de la filière agro-alimentaire est essentiel si l'on veut d'une part se préparer efficacement (documents, bases de données, organisation générale) aux situations de crise et d'autre part gérer au mieux une éventuelle crise, c'est à dire prendre les décisions les plus appropriées et savoir les justifier et les expliquer à la population et à ses divers représentants. Pour que ces experts soient pleinement efficaces dans le domaine nucléaire, il faut les informer, les sensibiliser et les faire participer, avec tous les autres acteurs, à des exercices de simulation de plus en plus réalistes.

**EFFORTS ENTREPRIS PAR ELECTRICITE DE FRANCE (EDF)
POUR REDUIRE LES REJETS LIQUIDES
HORS TRITIUM DES CENTRALES REP**

P. HARTMANN

Electricité de France
Service de la Production Thermique
Paris - La Défense

**ELECTRICITE DE FRANCE EFFORTS TO REDUCE RELEASED
RADIOACTIVITY (EXCLUDING TRITIUM) OF LIQUID WASTE IN PWR
NUCLEAR POWER PLANTS**

EDF operates a pool of nuclear power plants which now consists of 52 PWR units. The released radioactivity (excluding tritium) of liquid waste has been decreasing by a factor of about 10 for the last 10 years. This good result is due to :

- the modifications implemented to avoid the mixing of wastes of different origins and the improvement of certain treatment systems,
- the setting up of a management strategy including administrative targets and the necessity of reducing liquid waste arising at source.

These actions have also allowed to minimize the amount of solid waste and therefore their cost.

INTRODUCTION

Depuis 1977, EDF a mis en service et exploite un parc de production d'électricité qui comprend actuellement 52 réacteurs à eau sous pression REP.

Comme beaucoup d'activités industrielles, l'exploitation des centrales nucléaires engendre la production d'effluents et de déchets. Les effluents radioactifs liquides et gazeux des centrales nucléaires, qu'ils proviennent du réacteur ou des circuits des auxiliaires, sont collectés, traités et analysés avant d'être rejetés dans l'environnement suivant des modalités strictes définies par la réglementation française.

EFFORTS ENTREPRIS PAR EDF DEPUIS 10 ANS

Depuis 1980, EDF a engagé des actions visant à réduire les rejets des effluents radioactifs des centrales nucléaires à un niveau aussi faible que raisonnablement possible (principe ALARA).

Ces actions ont principalement porté sur :

- l'amélioration des circuits de collecte et de traitement des effluents liquides (tri des effluents par nature afin d'éviter les mélanges, et donc faciliter les traitements ultérieurs et la comptabilisation des volumes produits ; installation de moyens de traitement supplémentaires),
- la mise en place d'une organisation permettant une gestion rigoureuse des effluents et des déchets solides liés au traitement (motivation du personnel pour limiter la production d'effluents à la source lors des opérations de maintenance, création de comités de gestion chargés de fixer des objectifs et d'analyser tout dysfonctionnement, désignation d'un responsable par site pour la coordination des actions).

Ces mesures, introduites depuis 10 ans, ont permis de réduire de façon significative les volumes d'effluents produits et, par conséquent, les rejets de radioactivité hors tritium d'un facteur 10 en 10 ans (Fig. 1 et 2). Ces bons résultats se sont également accompagnés d'une diminution du volume des déchets solides liés au traitement (Fig. 3) et donc, des coûts correspondants.

Les rejets de radioactivité hors tritium des centrales françaises se situent actuellement aux environs de 25 GBq/tr x an soit 5 % de la limite fixée par la réglementation française ; l'impact sanitaire sur le public de cette limite étant lui-même 200 fois inférieur aux Normes de Base de la Communauté Européenne.

Ces rejets conduisent à des équivalents de dose de l'ordre de 10^{-8} Sv pour l'individu du public le plus exposé, ce qui est faible, voire négligeable comparé à la radioactivité naturelle ($2 \cdot 10^{-3}$ Sv en France en moyenne).

CONCLUSION

Bien que toute nouvelle action visant à réduire les rejets de radioactivité dans l'environnement serait sans incidence notable sur la santé des populations, les efforts entrepris par EDF depuis 10 ans seront poursuivis dans un souci de bonne gestion et de réduction des coûts liés aux traitements des effluents et des déchets solides.

BIBLIOGRAPHIE

1. Rejets radioactifs liquides, impact sur l'environnement
Note EDF-SEPTEN - 69628 VILLEURBANNE CEDEX
2. Arrêté du 10 août 1976 relatif aux règles propres aux centrales nucléaires à eau sous pression pour le rejet de leurs effluents radioactifs liquides

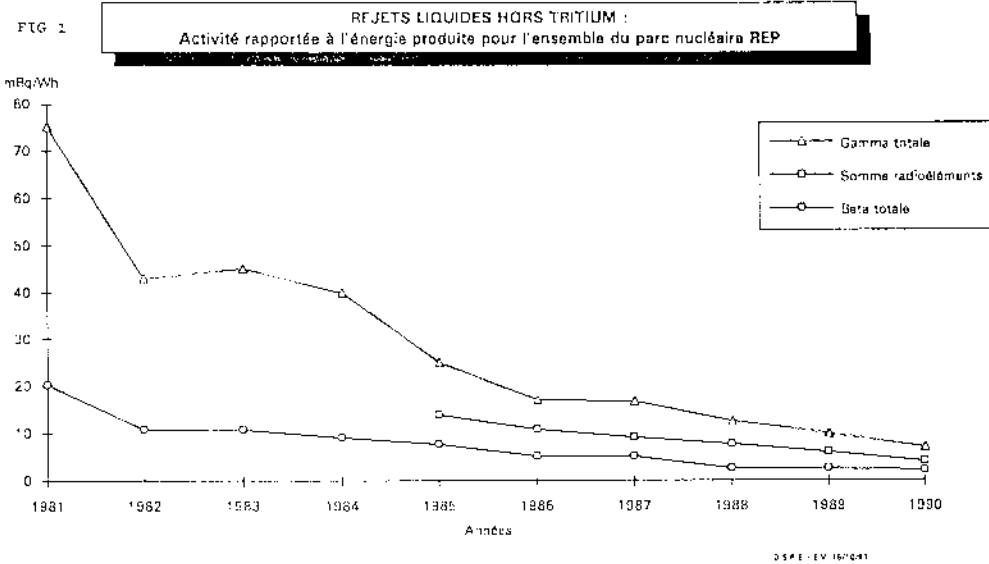

Figures relatives au texte

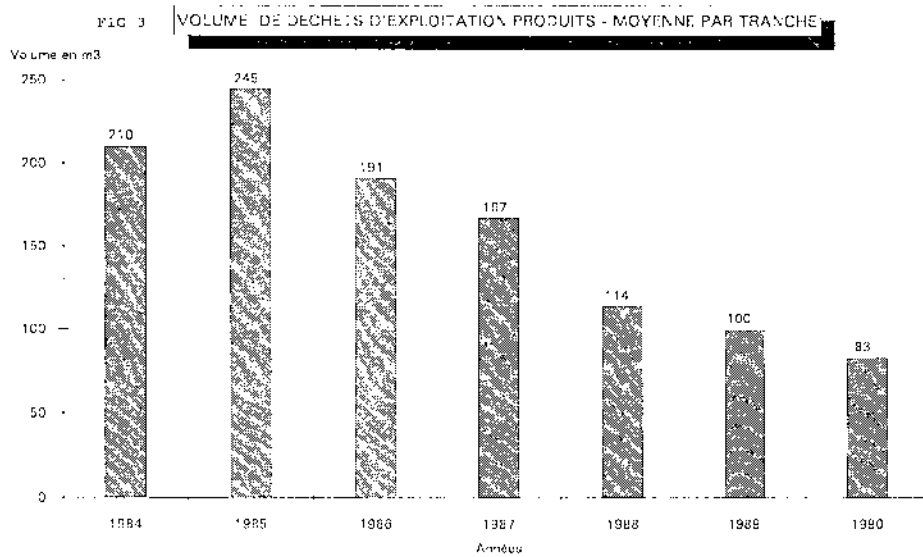
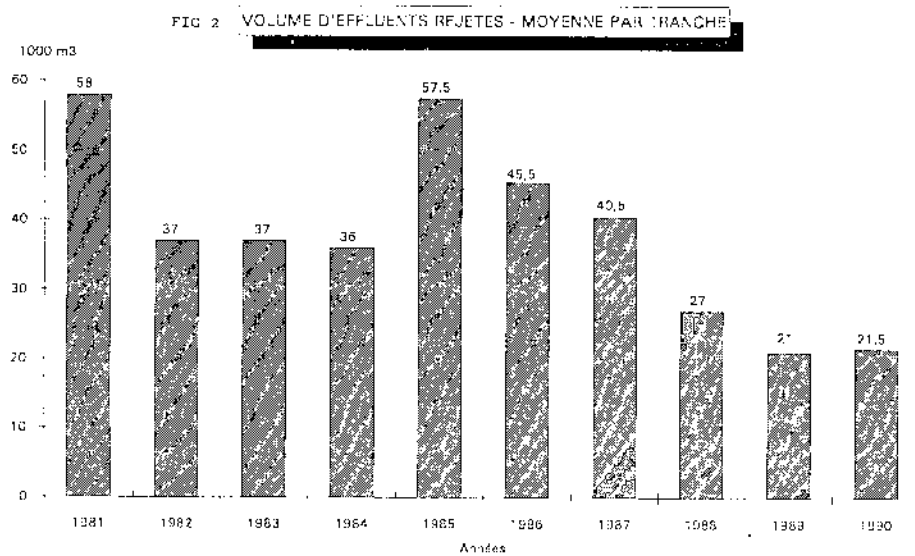

DISPERSION OF RADIONUCLIDES AND RADIATION EXPOSURE AFTER
LEACHING BY GROUNDWATER OF A SOLIDIFIED
CORE-CONCRETE MELT¹

A. Bayer*, W. Tromm, I. Al-Omari

Kernforschungszentrum Karlsruhe,
7500 Karlsruhe 1, Germany

ABSTRACT

After a core meltdown accident it cannot be completely ruled out that the melt will reach, and partly penetrate, the concrete foundation. The amounts of some radionuclides leached out by the passing groundwater are estimated. The transport of dissolved radionuclides in groundwater is simulated by an analytical dispersion model; the underlying parameters are the hydrogeological characteristics of the Upper Rhine Valley. Simple models are used to estimate the ensuing radiation exposures for various exposure pathways. A number of technical and administrative measures are indicated which allow the radionuclide concentration in the groundwater and the radiation exposure to be reduced considerably.

PENETRATION INTO THE REACTOR FOUNDATION OF THE CORE CONCRETE MELT

Findings of the "German Risk Study, Phase B" indicate that a core meltdown accident could well cause the melt to penetrate into the reactor foundation and pass through it down to the bottom side of the foundation within five days. Even if the passing groundwater were to prevent complete melt-through, there would still be a direct contact of the groundwater with the resolidified melt surface through fissures, cracks, etc., which could cause the fission products to be leached.

For the purpose of this study, the distribution of fission products and activation products within the melt is assumed to be roughly homogeneous. Of the volatile fission products, 10% of the original inventory is assumed to remain in the melt, while it is 100% of the others. From the point of view of radiation protection, three radionuclides have been found to be important in investigations of the resultant radiation exposures: Sr-90, Tc-99, and Cs-137.

LEACHING OF THE RESOLIDIFIED MELT, RADIONUCLIDE TRANSPORT

The resolidified melt is assumed to establish a contact surface vis-a-vis the groundwater with a diameter of 16 m. Because of the gaps and fissures in the concrete it may be assumed, by a way of approximation, that the actual contact surface area will be roughly a factor of 10 larger than the postulated one.

¹Since 1988 with the Bundesamt für Strahlenschutz, München-Neuherberg

As the resolidified melt is probably less resistant to leaching than the glass specially developed for final storage, for which a leaching rate of 10^{-4} g/(cm² x d), was determined, this number is increased by a factor of 100; this means that the estimate is based on a leaching rate of 10^{-2} g (cm² x d). In the light of the leaching experiments meanwhile performed at the Karlsruhe Nuclear Research Center with slag arising from the BETA experimental facility, this number may be considered to be conservative.

The distribution in the groundwater of radionuclides as a function of time and space was determined by an analytical solution of the transport equation:

The Philippsburg Nuclear Power Station, which is located on the Upper Rhine River, was selected as the reference site. The relatively homogeneous structure of the aquifer of that site allows the transport equation listed above to be solved analytically for the radionuclide concentration to be determined in this way. Some important hydrogeological data of the Upper Rhine Valley are listed in Table 1.

Table 1: Hydrogeological data of the Central Upper Rhine Valley

Thickness of aquifer:	M = 50 m
Porosity:	n = 0,2
Migration velocity:	v _a = 3,3 m/d
Dispersion coefficients:	D _x = 33 m ² /d D _y , D _z = 1,65 m ² /d
Bulk density:	ρ _B = 2,12 g/cm ³

EXPOSURE PATHWAYS TAKEN INTO ACCOUNT

Six exposure pathways were taken into account in the detailed study /2/.

The results obtained for two exposure pathways are described below:

- The incorporation of drinking water from groundwater (800 l/a). The drinking water consists of contaminated groundwater from the environment of the reactor, the basic assumption being that no decontamination processes are employed.
- The incorporation of drinking water from river water (800 l/a). The drinking water is taken from the river, again under the assumption of no decontamination processes being used.

RESULTS

Figure 1a shows the concentration in the groundwater and in the river water 500 m away from the reactor between 100 days and 100,000 days. The groundwater was assumed to be discharged into the river water 500 m from the reactor, and the discharge rate of the river was assumed to be 1000 m³/s.

The radiation exposures were determined on the basis of the concentrations found in the groundwater and in the river water. Figure 1b shows the effective equivalent dose for an adult. The following results were determined for groundwater:

Tc-99 is transported rapidly with the groundwater; it contributes to the radiation exposure practically throughout the entire leaching period. However, the radionuclide concentration and the effective equivalent dose of Tc-99 attain only relatively low levels of 10^6 Bq/m³ and approx. 10^{-3} Sv/a, compared to the other two nuclides. This is a consequence, above all, of the small inventory of Tc-99.

The highest radionuclide concentration of approx. 10^{10} Bq/m³ is reached by Sr-90 after some 5000 days. The effective equivalent dose for an adult is above 10^2 Sv/a. After a prolonged period of about 10,000 days, Cs-137 reaches a maximum of about 10^8 Bq/m³. The effective equivalent dose for this radionuclide is approx. 1 Sv/a.

The groundwater is highly diluted when entering the river water. Consequently, concentrations will be lower, as will be the radiation exposures, by an approximated factor of 10^3 .

COUNTERMEASURES

To limit radiation exposures by administrative measures, water extraction wells can be closed down, and the river water can be decontaminated in preparation of its use as drinking water.

Some technical measures, which may be taken to limit the spreading of radioactivity, are these:

- Installing impermeable walls around the plant.
- .. Pumping off the groundwater in order to dry the reactor foundation.
- Installing extraction pumps to prevent the groundwater from leaving the site.
- .. Making special use of soil freeze techniques.

In the light of those possibilities, it is meaningful to keep a set of decision-making methods ready in case a flexible intervention were required in a real accident situation.

REFERENCES

- 1 Gesellschaft für Reaktorsicherheit (GRS)
Deutsche Risikostudie Kernkraftwerke, Phase B
Report GRS-89 (1989)
- 2 A. Bayer, I. Al-Omari, W. Tromm
Abschätzung der Radionuklidverteilung und der Strahlenexposition bei Auslaugung einer erstarrten Kernmaterial-Beton-Schmelze durch Grundwasser
Report KFK-4512 (1989)

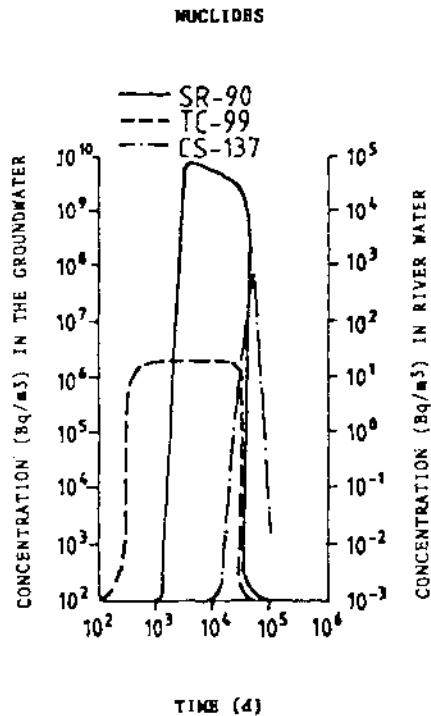

Fig. 1a:
Radionuclide concentrations in groundwater and river water;
distance from the reactor, 500 m.

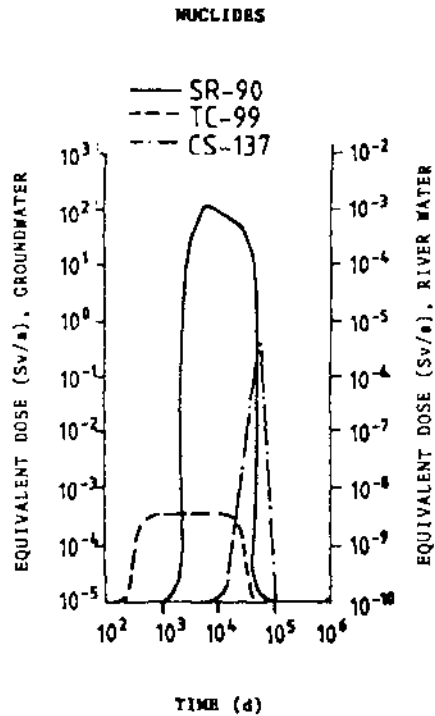

Fig. 1b:
Effective equivalent doses received by an adult as a result of
the incorporation of drinking water prepared from groundwater
and river water.

EVALUATION PROBABILISTE DU RISQUE ASSOCIE AU TRANSPORT AERIEN DU PLUTONIUM

Ph. HUBERT*, J. LOMBARD*, P. PAGES**, F. RANCILLAC**

*CEA/IPSN - BP n°6, 92265 Fontenay-aux-Roses cedex, France

**CEPN - BP n°48, 92263 Fontenay-aux-Roses cedex, France

PROBABILISTIC RISK ASSESSMENT OF PLUTONIUM AIR TRANSPORT

SUMMARY

A probabilistic risk assessment has been carried out in France for the air transport of plutonium oxide as a contribution to the continuous review of the IAEA Regulations. Based on accident data from IACO, the accident probability for a 6 000 km journey is $3.7 \cdot 10^{-6}$. The package failure rate for present packages resisting impacts at 80 or 90 ms^{-1} lies between 2 and $3 \cdot 10^{-7}$. This figure does not improve significantly with the use of reinforced packagings (meeting the 130ms^{-1} impact test). This work among others from US and UK led the IAEA to envisage more stringent requirements for air transport of radioactive materials packages and to propose a 85 ms^{-1} impact test.

RESUME

Dans le contexte de la révision périodique de la réglementation, l'AIEA a décidé d'examiner l'opportunité d'une réglementation spécifique pour le transport aérien. La France a contribué aux travaux préparatoires en réalisant une évaluation probabiliste du risque sur le transport aérien du plutonium. Sur la base des données internationales d'accident, la probabilité d'accident pour un trajet de 6 000 km est de $3,7 \cdot 10^{-6}$. L'emploi de colis résistant à des impacts de l'ordre de 80 à 90 ms^{-1} conduit à une probabilité d'ouverture de 2 à $3 \cdot 10^{-7}$ par trajet. Au delà de ces valeurs, l'amélioration des colis (résistant par exemple à des impacts de 130 ms^{-1}) n'améliore pas sensiblement ce résultat. Cette étude, parmi d'autres, a conduit l'AIEA à envisager des critères plus stricts pour le transport aérien de matières radioactives et à proposer un test d'impact à 85 ms^{-1} .

INTRODUCTION

Pour toute matière radioactive, la réglementation AIEA actuelle est satisfaite par l'utilisation de colis B qui doivent subir des tests de résistance à l'impact (chute de 9 m sur surface rigide soit une vitesse d'impact de 13,4 ms^{-1}) et à l'incendie (feu de 30 minutes à 800°C). Ces tests sont insuffisants pour représenter le type d'environnement accidentel propre au transport aérien. Une première évaluation probabiliste du risque a été faite aux Etats Unis en 1977 [1]. Plus récemment, dans un travail pour les Communautés [2], Brown et al se sont posé le problème des critères d'essai pour les colis destinés au transport aérien. L'étude présente [3][4] vise à la fois l'estimation du niveau de risque correspondant à la conception du colis aujourd'hui utilisé en France pour le transport de l'oxyde de plutonium issu du retraitement, et l'examen de la pertinence d'un renforcement de l'emballage destiné au transport aérien. Les résultats des différentes étapes de l'étude sont

brièvement présentés ci-dessous.

ACCIDENTOLOGIE AERIENNE

Le but de cette étape est de définir, de façon probabiliste, l'environnement accidentel - c'est à dire les contraintes susceptibles de s'appliquer à un colis de transport de plutonium. En principe cette partie de l'étude n'est pas spécifique d'un colis, toutefois l'analyse faite concerne essentiellement le cas de colis de l'ordre de quelques tonnes. Sur la base des accidents aériens tels qu'ils sont recensés par l'Organisation Internationale de l'Aviation Civile (OACI), l'arbre des événements d'un accident a pu être quantifié (figure 1).

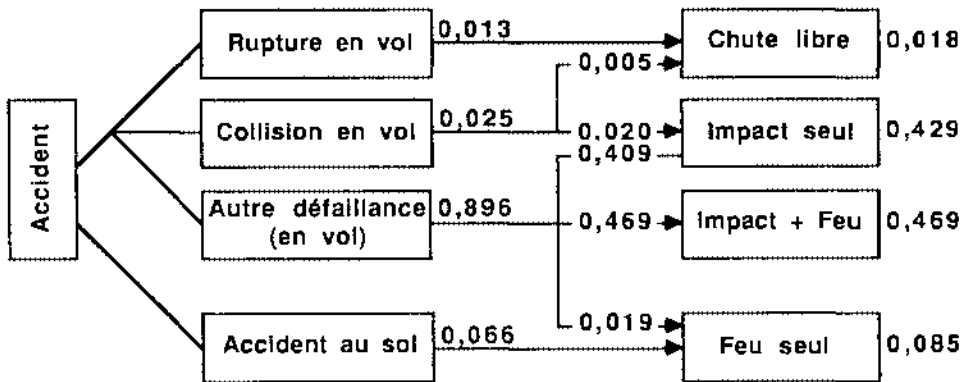

Figure 1: Arbre des événements de l'accident aérien.

Les taux d'accidents utilisés sont tirés de [2]. Ils sont définis pour chaque phase de vol (décollage, montée, en route, approche, atterrissage) et varient en fonction de la longueur du trajet. Pour des trajets de 1000 ou 6000 km, les valeurs sont respectivement de $1,2$ et $3,7 \cdot 10^{-6}$ accident par vol (sans escale). La grande fréquence des feux est à noter, ainsi que leur gravité : Température et durée sont supérieures à celles des tests de l'ATEA pour les colis de transport (800°C , 30mn). Toutefois à cause de la grande dispersion des épaves et du bon comportement du colis, l'analyse a été centrée sur l'impact, dont la gravité a été exprimée en fonction de la vitesse réelle observée et de l'angle d'impact au sol. La rigidité du sol est traduite par un coefficient de réduction de la vitesse réelle.

ACCIDENTOLOGIE ROUTIERE

Les études classiques ont fait l'objet de développements spécifiques pour estimer quantitativement les scénarios très rares (par exemple coincement entre deux camions en choc frontal) susceptibles de produire des contraintes très sévères [3].

LA REPONSE DU COLIS ET LES TAUX D'OUVERTURE

Le comportement du colis est lié au seuil de résistance aux contraintes exprimé ici comme une vitesse d'impact (vitesse équivalente à un impact sur surface rigide). Pour les colis utilisés aujourd'hui (FS 47) le seuil serait de l'ordre de 80 ms^{-1} (cf campagne d'essais COGEMA). Le tableau I présente les probabilités d'ouverture pour trois trajets.

Tableau I: Probabilité d'ouverture des colis de transport selon leur résistance pour un trajet type

	Vol de 6 000 km ($3,7 \cdot 10^{-6} \text{acc}$)	Vol de 1 000 km ($1,2 \cdot 10^{-6} \text{acc}$)	Route : 1 000 km ($2,5 \cdot 10^{-4} \text{acc}$)
Colis résistant à un impact à:			
80 ms^{-1}	$0,33 \cdot 10^{-6}$	$0,95 \cdot 10^{-7}$	$6,5 \cdot 10^{-7}$
90 ms^{-1}	$0,20 \cdot 10^{-6}$	$0,66 \cdot 10^{-7}$	$3,3 \cdot 10^{-7}$
130 ms^{-1}	$0,13 \cdot 10^{-6}$	$0,42 \cdot 10^{-7}$	$0,16 \cdot 10^{-7}$

LES CONSEQUENCES D'UN RELACHEMENT

Le calcul des conséquences nécessite la connaissance de la composition isotopique du mélange, de sa granulométrie et de la quantité relâchée. Pour le mélange étudié, la composition dérive du retraitement du combustible PWR irradié à 33000 MWjt^{-1} et refroidi 3 ans. Sa granulométrie correspond à un diamètre aérodynamique médian de 10 microns. Les essais destructifs réalisés par la Sandia ont montré que même un colis détruit ne relâchait pas tout son contenu. Le taux de relâchement a été fixé ici à 5% du contenu. Le facteur de dose calculé pour une granulométrie de 1 micron (estimation conservatrice) est de $1,8 \cdot 10^6 \text{ Sv}$ par gramme inhalé. Dans les conditions atmosphériques stables avec un vent de 1 ms^{-1} , un individu pourrait recevoir une dose de 1 Sv à 434 m pour un relâchement de 10 g. Sous l'hypothèse d'une densité démographique de 100 hab.km^{-2} (moyenne de la France), la dose collective est de l'ordre de $1,5 \text{ hSv}$ par gramme de mélange rejeté à l'atmosphère.

ESTIMATION DU RISQUE

En reprenant les hypothèses précédentes (granulométrie, composition du mélange, 100 hab.km^{-2} , 5% de rejet) on peut associer aux événements précédents (tableau I) l'espérance mathématique de la dose collective. Ce calcul a été effectué pour une cargaison de 150 kg, ce qui correspond à 10 colis et sensiblement au retraitement du combustible associé à l'exploitation d'un Gwe pendant un an (cf tableau II). Il faut noter la relative faiblesse du risque mesuré par l'espérance de la dose collective (associée toutefois à des événements de probabilité faible : 10^{-7} par trajet). Le transport aérien présente un risque, par kilomètre parcouru, plutôt moindre que celui dû au transport routier, à cause de la plus faible occurrence des accidents. Remarquons que le transport aérien, par rapport à la route, est d'autant plus recommandé que le colis est moins résistant. En fait la sécurité repose là sur le vecteur de transport.

Tableau II: Espérance mathématique des doses pour un trajet type [hSv]

	Vol de 6 000 km	Vol de 1 000 km	Route : 1 000 km
Colis résistant à un impact à:			
80 ms ⁻¹	3,7 10 ⁻³	1,1 10 ⁻³	7,3 10 ⁻³
90 ms ⁻¹	2,2 10 ⁻³	0,74 10 ⁻³	3,7 10 ⁻³
130 ms ⁻¹	1,5 10 ⁻³	0,47 10 ⁻³	1,8 10 ⁻⁴

CONCLUSIONS

L'examen de la fréquence des accidents de gravité extrême et les résultats précédents montrent qu'il paraît peu intéressant d'envisager des colis résistant au delà de 90 ms⁻¹. En effet, une faible réduction des doses collectives nécessite un accroissement très grand de la résistance des colis. Cette amélioration des performances atteint assez vite la limite des possibilités techniques, et s'effectue dans un domaine où la croissance des coûts est extrêmement forte.

L'AIEA n'a pas jugé inquiétante la situation présente (cf résultats ci-dessus), mais elle a observé que ce niveau de sûreté reposait sur le fait que les concepteurs ont mis au point des emballages considérablement plus solides que ne l'exige la réglementation présente. En conséquence l'Agence a jugé nécessaire de consolider cet état de fait par une prescription réglementaire adaptée. La valeur de 85 ms⁻¹ a été finalement proposée [6] comme vitesse du test d'impact pour le transport aérien de matières radioactives.

REFERENCES

- [1] Mr. Sweeney T.I et al, An assessment of the risk of transporting plutonium dioxide by cargo aircraft, BNWL 2030, Batelle, 1977.
- [2] Brown M.L. et al, Specifications of the test criteria for containers to be used in the air transport of plutonium, Rapport EUR 6994, CCE, Bruxelles 1980.
- [3] Degrange J.P., Hubert P., Pagès P., The transport of plutonium oxide. A study of air and road accidents. Report 138, CEPN, 1989 (disponible en Français).
- [4] Lombard J., Hubert P., Pagès P., Analysis of events resulting from an accident involving an air transport of plutonium oxide, Report 135, CEPN, 1988, (disponible en Français).
- [5] Rancillac F. et al., Evaluation de la faisabilité des contre-mesures associées à un accident de transport aérien de plutonium, in IRPA'92, 17-22 Mai 1992, Montréal, Québec, Canada.
- [6] AIEA, The air transport of radioactive material, version provisoire de la proposition de recommandation, Mai 1991.

CONTAMINATION MEASUREMENTS ON PERSONS
AFTER A NUCLEAR ACCIDENT

R. Maushart

Laboratorium Prof.Dr.Berthold GmbH & Co.
Wildbad, Germany

ABSTRACT

The purpose of contamination measurements after accidents is threefold: to detect and localize contaminations; to determine the level of contamination as a base for medical decisions; and to check the scope and efficiency of the decontamination measures.

Persons involved in accidents should never measure their contamination themselves. The radiation protection personnel, whether it belongs to the medical team or to the disaster control squads, must be familiar with the measuring instruments and experienced in handling these instruments. A high priority has to be placed on training and constant practice.

The monitors used must meet the special requirements of an emergency situation. This includes resistance against environmental factors - temperature, humidity, vibrations - as well as the simplicity of handling the instrument, and the clear presentation of the results.

CONTAMINATION MEASUREMENTS AND MEDICAL CARE OF PERSONS ADDITIONALLY CONTAMINATED

Several international and national guidelines exist for treating persons exposed to radiation or contaminated after a nuclear accident (1, 2, 3). However, they focus almost exclusively on the medical care, without discussing the necessity, let alone the practical performance, of procedures related to a contamination measurement.

It seems justified, therefore, to clarify the role and purpose of contamination measurements in the medical treatment of contaminated persons. In the course of the decontamination process, four steps can be emphasized for the measuring technique: detecting - preventing - ensuring - documenting.

First, the level and extensions of person contaminations have to be determined. Particularly, if a large number of persons have been contaminated, these measurements serve as a basis for determining where the high level of contamination requires that immediate steps be taken, and where a treatment is less urgent (the treatment itself is beyond the scope of this paper).

A second purpose of the measurements is to prevent immediate harmful effects of the contamination. For the affected person this is a too high skin dose, on the one hand, and the incorporation of the activity through possible wounds.

With regard to the staff one has to make sure that contamination cannot be passed on or neglected. This is equally true for staff, environment and instruments.

Third, contamination measurements should ensure that the provisions taken have been effective. During person decontamination the success has to be checked by measurement until the desired values have been reached. Moreover, the measurement has to rule out any chance that contaminations are missed.

Finally, the results of the measurement are used for documentation purposes. This documentation is required not only for a later analysis and evaluation of the accident and its consequences; it also serves for clarification of possible legal claims of the affected persons.

Regardless of the great importance of contamination measurements in the course of decontamination procedures, one has to say clearly that the medical treatment always has priority in an emergency. In some situations no measuring instruments may even be available at all, but a decontamination has to be performed nevertheless.

However, a professional medical treatment of contaminated persons can only be ensured in conjunction with a professional contamination measuring technique.

TYPE AND NUMBER OF INSTRUMENTS REQUIRED

The most important instrument for measuring contaminated persons is a portable contamination monitor with large-area detector (at least 100 cm² area). How many of these instruments are required is dependent upon the planned person throughput of a decontamination facility.

Two aspects should be considered. On the one hand, it is advisable to keep separate instruments for the "hot" entrance area and the "cold" exit area - and to label them accordingly! - in order to avoid crossover contamination between early and late decontamination areas. On the other hand, spare instruments should be available in the event of heavy contamination or when one instrument is defective.

It is also advisable to provide wall holding devices for the portable instruments. There, the monitors can be "parked" when they are not being used; they may also serve as semi-stationary hand monitors for the staff.

Larger facilities should provide one or several stationary hand-foot-monitors at the entrance and exit, which should be equipped with result printers. At least the instruments positioned at the entrance should be provided with a contamination protection (foil). Patients may enter the monitors positioned at the entrance only under the supervision of the staff performing the measurement. The staff enters the patient's ID prior to the measurement which will then be documented together with the result of the measurement.

The contamination monitors should indicate the result as area-related activity in the unit Bq/cm² (discussion and reason for this requirement in (). A proper calibration is required. The bases for this are national and international standards (4,5). Calibrations are essentially type test which are performed by the manufacturer.

Regardless of the calibration, a regular function check of the monitors is required. This is simply a good laboratory praxis. Suitable test sources are usually supplied by the instrument manufacturers.

REQUIREMENTS FOR CONTAMINATION MONITORS

When checking persons involved in an accident for contamination, who may even be injured, this is usually done under difficult conditions. The difficulties are, on the one hand, of a psychological nature, such as stress, insecurity, improvisation and high time pressure; on the other hand, there are the concerns of the environment in which these measurements have to be carried out. Due to the fact that for decontamination a person has to wash, shower and change clothing all the time, it may be wet, warm, crowded, and noisy. Moreover, the visibility may be quite bad due to vapour or insufficient light. Therefore, contamination measuring instruments have to meet special requirements to make sure that reliable results will be obtained.

These requirements concern the mechanical as well as the electronic construction of the measuring instruments. The key words "robust" and "moisture resistant" characterize the mechanical, and "intelligent" the electronic features. There is, however, an additional requirement concerning the simple and reliable handling of the monitor. It is characterized by the terms "simple and clear".

Of particular importance is the quick response of the monitor. Especially when detecting contaminations it is necessary that the result indication adjust as quickly as possible to the changes of the current measured value, without becoming blurred by random statistical variations. Modern micro-processors can be taught to behave accordingly via software. Furthermore, for the clear readability of the measured value it is quite useful to display only the statistically significant number of decimals.

In general, the requirement is to implement a high level of intelligence into the monitor electronics. This facilitates the user's own decisions and interpretations. It not only helps to avoid errors and mistakes, but enables the operator to focus his attention on the execution of the measurements, rather than on the instrument.

STAFF TRAINING AND PRACTICE

Even if the contamination monitors which are available after an accident meet all the requirements listed above: their professional use still requires well-trained and practised staff.

Persons accidentally contaminated should never measure themselves, not even if they have sufficient experiences in this field. The reason is not only a possible accident shock; it also has to be ensured that all persons involved will be measured according to the same routine and with the same care.

This indicates where training has to start. In addition to the actual handling of the measuring instrument, the execution and procedure of person contamination measurements, the interpretation of measured values and the documentation have to be taught and practised as well.

The importance of constant practice cannot be emphasized enough, although we cannot go into details. This can be combined with a regular function check of the instruments, which is required any way.

This principle is applicable, of course, for all emergency applications and is discussed in detail in (7).

REFERENCES

1. Schulte, B., Wissenswertes für den Arzt zur Behandlung Strahlenexponierter; ISH-Heft 132, März 1989; ISBN 3-89254-070-5 (German translation of IAEA-TECDOC-366, 1989)
2. Management of Persons Accidentally Contaminated with Radionuclides; NCRP Report No. 65, 1980
3. ICRP Publication 28, Principles and General Procedures for Handling Emergency and Accidental Exposures of Workers, Annals of ICRP Vol. 2 No. 1, 1978
4. DIN 44801 Teil 1 "Oberflächen-Kontaminationsmeßgeräte und -monitoren; Allgemeine Festlegungen; Oktober 1984
5. ISO/DIS 8769; "Reference Sources for the Calibration of Surface Contamination Monitors"; and ISO/DIS 7503/1 "Evaluation of Surface Contamination", 1987
6. Maushart, R., Überwachung der Radioaktivität in der Umwelt; GIT-Verlag Darmstadt 1989, S. 195 ff. ISBN 3-921956-83-8
7. Maushart, R., Monitoring Instruments are Constantly Improved, - but how to Improve the Instrument User? A Plea for Intelligent Training; in "The Radioecology of Natural and Artificial Radionuclides", W. Feldt, Edt., FS-89-48-T, Verlag TÜV Rheinland, Köln 1989, ISBN3-88585-668-9

THE USE OF AN INCOMPLETE INFORMATION DATA BASE
FOR THE ASSESSMENTS DURING THE EARLY PHASE
OF AN ACCIDENTAL RELEASE OF RADIOACTIVE MATERIAL

A. Sohier and P. Govaerts

Studiecentrum voor Kernenergie/
Centre d'Etude de l'Energie Nucléaire (SCK/CEN)
Radiation Protection Research Unit
Boeretang 200
B-2400 Mol, Belgium

ABSTRACT

The information necessary to introduce countermeasures in the environment in the early phase following an accidental radioactive release will be vague. A method to rapidly reduce gross uncertainties of the radiological picture will be incorporated as a part of a European emergency response system. Basically, it involves the tuning of the main parameters of a general dispersion model by continuous comparison of the model output with early radiological survey data in a feed-back loop.

INTRODUCTION

Following a major accidental release of radionuclides to the atmosphere appropriate countermeasures must be taken to mitigate the consequences to the population and the environment.

During the time lapse from the notification of an anomaly to the early phase following an accidental release only computer simulations based on real-time in-plant information and meteorological data will be available. A poor and uncertain knowledge of the main model parameters will possibly lead to erroneous and cost-ineffective decisions. On the other hand a global comprehensive view of the environmental contamination based only on measurements will emerge after an unacceptable long time delay. A possible way out of these difficulties is to organize an optimization scheme to acquire a confident knowledge of the actual and future radiological situation by comparison of model output, using a general dispersion model, and early radiological survey data in a feed-back loop. Once the gross uncertainties have been resolved model based extrapolations of the radiological situation will be possible.

OPTIMIZATION TECHNIQUES

The feasibility of feed-back will heavily rely on the availability of environmental survey data. Two optimization schemes were considered. The first one, as shown in fig. 1, is based on the comparison, using an acceptance criterion, of measured and calculated data. Basically the deviation between measurements and computation, as quantified by a comparison criterion, is minimalized. The fulfilment of an

acceptance criterion has to guarantee a sufficient quality of the optimization. If according to this criterion a convergence of model results towards survey data cannot be achieved, the optimization cycle has to be performed on a reduced measurement data set rejecting outlying data.

The main drawback of this method, if applied blindly, is the generation of solutions which fit well mathematically but without relation to the physical reality (ref. 1). For example, if extrapolating the calculations to other places, using the optimized set of input-parameters, most certainly the accordance between measured values and the corresponding computed value of the physical quantity under consideration will be very bad if an adequate sampling scheme is not followed in the determination of these input parameters. For this reason this optimization scheme is transformed to a regression of measured data, assuming the validity of a general dispersion model as shown on fig. 2.

In simple terrains the main sources of uncertainties are : wind direction, source term, effective height, dispersion parameters and wind speed.

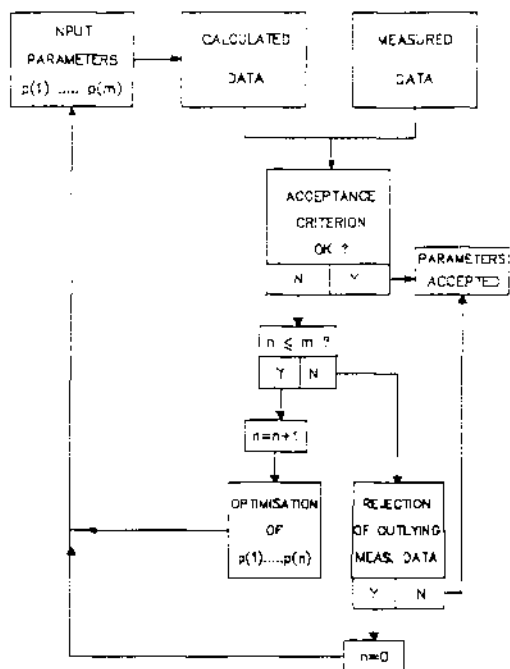

Fig. 1 : General scheme of the optimisation system (first approach)

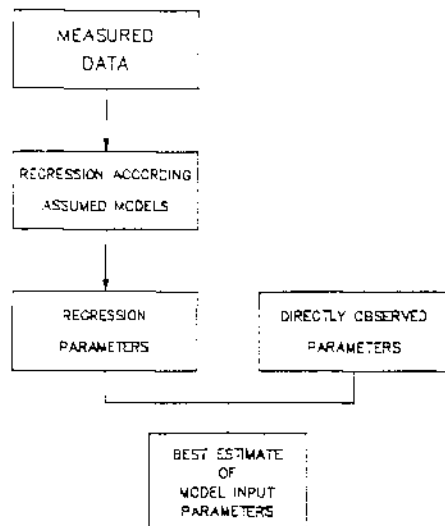

Fig. 2 : General scheme of the optimisation system (second approach)

An environmental sampling strategy must be worked out carefully. The most reliable survey methodology promises to be a sampling on several rings lying at different distances from the source around the ground level projection of the plume axis, cutting off too low values of measurements to avoid a "noise" (ref. 2).

ALTERNATIVE METHOD : FUZZY LOGIC

An increasing number of practical optimization systems use the so-called fuzzy logic instead of numerical optimization techniques. Fuzzy logic is appropriate to translate a qualitative judgement into a degree of membership to a given group. A logic has been developed to derive a degree of "possibility" or "necessity" to conclusions, based on the combination of several fuzzy information (ref. 3).

Each environmental observation O can in this way be appreciated and qualified as e.g. in very good agreement, good agreement, poor agreement, very poor agreement with the predictions P , using an agreement membership function. An application of the fuzzy logic might allow to define boundaries to the possible values of the model input data or parameters.

This approach has been combined with an analysis of spatial distribution of P/O ratios. A variation of a key-parameter of the prediction model will introduce a specific spatial distribution of the P/O ratios. In a normal situation with a good fit between predictions and observations the P/O ratios are distributed symmetrically around 1, without any correlation between the P/O ratio and the geographical position. An artificial decrease of the source term, e.g. will decrease all the P/O ratios. A shift in wind direction will decrease the P/O values under the real wind direction and increase the ratios under the assumed wind direction. Analogous graphical transformations of the P/O distributions can be associated with variations of other parameters. After an analysis of typical P/O distributions an expert system will be developed to propose variations to the input parameters, transforming the P/O ratio distribution to an acceptable distribution centered around 1, without a spatial correlation.

PRACTICAL IMPLEMENTATION

In the framework of radiation protection research programmes of the Commission of the European Communities (DGXI and DGXII) an European emergency decision support system covering all time phases and distance ranges after a nuclear accident is under development. The main emphasis has been put on the early stage, where quick and reliable predictions are required in real-time taking due account of on-line monitoring data and environmental measurements (ref. 4).

Independently of the actual realization of the optimization technique the necessary interface to accept environmental measurements, such as γ -dose rates, activity air concentrations and soil contamination, to compare them with model predictions have been foreseen in a separate system module.

CONCLUSION

A design has been developed for inclusion of early environmental data into an optimization procedure in case of a nuclear accident, to improve confidence in model prediction. An analysis of tracer experiments has shown the opportunity as well as the drawback of applying several methods to feed-back monitoring data into a model. This will only be possible by application of a strict environmental sampling strategy. The most promising method candidate for implementation in the European decision aiding system is based on the analysis of the distribution of P/O ratios following the variation of certain key parameters.

ACKNOWLEDGEMENTS

This work has been co-sponsored by the CEC - DG XII Radiation Protection Programme under contract nr. Bi6-106.

REFERENCES

1. Govaerts, P. and Sohler, A., 1988. Feedback of Environmental Survey Data for the Optimization of the Input Parameters of Assessment Models During an Emergency. Commission of the European Communities, Joint OECD (NEA) Workshop on Recent Advances in Reactor Consequences Assessment, Rome, Italy.
2. Govaerts, P., Sohler A. and Zeevaert T., 1990. Optimization of dose assessment models including the interface with environmental survey for use in case of accidental releases, in Proceedings of the seminar on methods and codes for assessing the off-site consequences of nuclear accidents, Athens, Report EUR 13013, Vol. 1.
3. Zadeh, L.A., 1965, Fuzzy Sets, Inf. Control, 8, 338.
4. Commission of the European Communities, DGXII-D-3 Radiation Protection Programme, DGXI-A-1 Radiation Protection. The design of the overall structure of a comprehensive decision-aiding system for nuclear emergencies in Europe following an accidental release to the atmosphere, version 9/91. Kernforschungszentrum Karlsruhe GmbH (FRG), Institut für Neutronenphysik und Reaktortechnik.

DEVELOPPEMENT DES VEHICULES PLAN D'URGENCE INTERNE

R. DOLLO, S. RENIER, Y. TESTINI

ELECTRICITE DE FRANCE
SERVICE DE LA PRODUCTION THERMIQUE
PARIS-LA DEFENSE (FRANCE)

M. SONTAG

Société ARIES
(FRANCE)

DEVELOPMENT OF ON-BOARD VEHICLE MEASUREMENTS FOR EMERGENCY SITUATIONS

ABSTRACT

In case of accident in a nuclear power plant, measurements must be carried out very quickly around the site, in order to control and limit the consequences for the population. Measurements which have the priority are the gamma dose rate, the total beta activity, the gamma activity due to I 131 (charcoal filter) and due to Cs 134/137 (paper filter). To fulfill the requirement, EDF has developed and selected necessary equipments, putting the emphasis on the reliability and on the ease of use. A computer controlled system dedicated to dose rate measurement and gamma spectroscopy is described, as well as an autonomous programmable, air and water sampling device.

1. INTRODUCTION

En cas d'incident ou d'accident survenant sur une installation nucléaire, il est prévu de mettre en oeuvre une organisation de crise pour maîtriser la situation, limiter et surveiller la dispersion des produits radioactifs dans l'environnement, dans le but final de minimiser les conséquences sanitaires pour les populations.

Cette organisation consiste à mettre en place :

- des actions internes : le Plan d'Urgence Interne (P.U.I.), c'est-à-dire la mobilisation immédiate des équipes pour protéger le personnel et limiter les effets de l'accident ;
- des actions externes liées à l'environnement du site : le Plan Particulier d'Intervention (P.P.I.).

C'est le Préfet de la région concernée qui met en oeuvre le P.P.I. et qui décide et coordonne les actions des Pouvoirs Publics, visant à la protection des populations et de l'environnement au voisinage du site.

Pour prendre ses décisions, le Préfet s'appuie principalement sur les conseils de la Direction de la Sécurité des Installations Nucléaires (D.S.I.N.) du Ministère de l'Industrie et du Service Central de Protection contre les Rayonnements Ionisants (S.C.P.R.I.), organisme dépendant du Ministère de la Santé.

De plus, il dispose de nombreux moyens d'intervention :

- Centre de Secours des sapeurs pompiers ;
- Cellules Mobiles d'Intervention Radiologiques (CMIR) ;
- moyens de contrôle de la radioactivité par le Commissariat à l'Energie Atomique (C.E.A.) ;

Dès les premières heures, l'exploitant transmet des informations au Préfet sur :

- les rejets en cours, le cas échéant ;
- l'évaluation prévisionnelle des rejets potentiels, compte tenu de la nature de l'accident et des conditions météorologiques ;
- les résultats des mesures pratiquées sur le site et à l'extérieur du site.

Pour ce dernier point, la réglementation fixe l'obligation de disposer d'au moins deux véhicules laboratoire tout terrain pour réaliser les mesures dans l'environnement.

Compte tenu de l'importance du parc nucléaire et de la défiance du public vis-à-vis des informations contradictoires sur les niveaux de radioactivité dus à l'accident de Tchernobyl, EDF a décidé de réexaminer les choix faits lors du démarrage du programme électronucléaire en 1978.

En 1990, un Groupe de Travail, constitué d'exploitants, a eu en charge :

- d'établir le besoin en mesures radioactives
- de définir des choix technologiques et méthodologiques communs à l'ensemble des sites EDF
- de faire valider les appareils et procédures de mesure
- de créer des séances de formation à l'usage des futures opérateurs

La livraison des premiers véhicules est prévue fin 1991.

2. DEFINITION DU BESOIN

En situation accidentelle, les mesures prioritaires sont les mesures de débit de dose, en des points situés sous le vent.

Ces premières mesures sont ensuite complétées par des mesures sur les filtres, frottis et cartouches à charbon actif, à savoir :

- . activité bêta totale sur filtres et frottis,
- . activité spécifique des radio-éléments les plus contraignants pour l'environnement (spectrométrie gamma simplifiée : mesure globale halogènes par la mesure I 131 et mesure globale des aérosols par la mesure Cs 134 + Cs 137).

Enfin, il pourra être effectué des prélèvements de végétaux, lait et sol.

3. CHOIX DU MATERIEL

Le matériel de mesures sur le terrain doit être fiable, transportable et d'utilisation simple.

Les dispositifs de prélèvements et de mesures doivent être embarqués à bord des véhicules afin de les soustraire au rayonnement ambiant et de limiter leur contamination.

Pour s'affranchir d'une panne éventuelle d'un véhicule, ou de l'appareillage, les matériels embarqués doivent être identiques et interchangeables.

Les plages de mesure des appareils ont été déterminées à partir des calculs des conséquences des éventuels accidents, y compris les accidents graves.

Les types de matériels à embarquer sont les suivants :

- . matériel de transmission,
- . matériel de radioprotection et de contrôle individuel,
- . matériel de prélèvement,
- . matériel de mesures,

3.1. Matériel de transmission

Il est constitué d'un poste émetteur-récepteur permettant la liaison avec le site nucléaire.

3.2. Matériel de radioprotection et de contrôle individuel

Il est composé de :

- . gants et surbottes vinyl,
- . combinaisons légères jetables,
- . appareil respiratoire autonome,
- . films dosimètres,
- . stylo-dosimètres à lecture directe couvrant la gamme 0 à 10 Gy ou dosimètres électroniques.

3.3 Matériels de prélèvements

Pour disposer d'un matériel adapté aux conditions du terrain, EDF a fait développer un ensemble portable et autonome qui permet en plus des prélèvements d'air, d'effectuer des prélèvements de pluie : la "BAP 10" balise autonome de prélèvement (Société ARIES).

Ce système permet la réalisation de 4 prélèvements (quantification aérosols/halogènes) de 1 m³ d'air, et d'effectuer en parallèle la mesure en continu du débit de dose (avec enregistrement). Plusieurs modes de prélèvements peuvent être utilisés :

- . déclenchement immédiat,
- . déclenchement sur dépassement de seuil (prérégulé) ou consigne horaire.

Chaque véhicule est équipé de deux systèmes.

3.4 Matériel de mesures

MESURE DE DEBIT DE DOSE GAMMA AMBIANT

Pour répondre aux besoins, il a été décidé de disposer d'un appareil portable et autonome pour réaliser les mesures à l'extérieur et d'un appareil en fixe installé dans une fenêtre de la paroi interne du véhicule, couplé à un micro-ordinateur, capable d'effectuer des mesures, soit à l'arrêt, soit en mouvement.

Appareil portable et autonome : 1 par véhicule

Les spécifications sont les suivantes :

- . appareil robuste, léger et simple d'utilisation,
- . autonomie minimale de mesures de 48 heures,
- . étendue d'échelle de 10^{-8} à 0,5 Gy/h,
- . lecture directe en Gy/h,
- . mesure de rayonnement gamma pour des énergies comprises entre 50 Kev et 2 Mev.

Appareil en fixe dans le véhicule : 1 par véhicule

Les caractéristiques de la sonde de détection sont identiques à celles de l'appareil portable.

La complémentarité de cet appareil réside dans la possibilité de réaliser des mesures (continues ou ponctuelles) en roulant et grâce au couplage à un micro-ordinateur, de permettre des restitutions beaucoup plus performantes (historique et repérages géographiques).

MESURE DE L'ACTIVITE BETA TOTALE DES FILMS PAPIER

Chaque véhicule est équipé d'un dispositif de mesure de l'activité bêta totale.

L'activité à mesurer est comprise entre quelques Bq/m³ et 10 000 Bq/m³ (pour 1 m³ d'air prélevé et 10 minutes de comptage).

MESURE DE L'ACTIVITE SPECIFIQUE AEROSOLS/HALOGENES RETENUE SUR FILTRE ET CARTOUCHE A CHARBON ACTIF

Les mesures d'activité spécifique des éléments les plus déterminants - Iodes et Césiums- doivent pouvoir être effectuées en dehors du laboratoire d'environnement, afin de se prémunir d'une éventuelle contamination de celui-ci et surtout, de faciliter l'organisation des tâches.

L'analyse a conduit à rechercher un équipement à embarquer dans chaque véhicule, de spectrométrie gamma NaI, très simplifié qui soit capable, avec un minimum de manipulation (calibration automatique des spectres), de quantifier l'Iode 131, les Césiums 134 et 137 (mesures globales dans des fenêtres d'énergie prédéterminées), sans arrêter le véhicule et tout en conservant simultanément la mesure du débit de dose.

L'appareil SYME.10 développé par la Société ARIES a été retenu par EDF.

Le SYME.10 (SYStème de Mesures Embarqué) est un système, dont la partie centrale (microprocesseur) est commune avec la mesure du débit de dose et les balises de prélèvement.

MOBILE MONITORING UNIT FOR ASSESSING ENVIRONMENTAL RADIOACTIVE CONTAMINATION

A. Andrási, I. Fehér, I. Németh, J. Urbán and P. Zombori

Atomic Energy Research Institute of the Central Research Institute for Physics, Budapest P.O. Box 49, H-1525, Hungary

ABSTRACT

Mobile monitoring laboratory has been established for monitoring environmental radiation first of all in accidental conditions but which is also suitable for monitoring radiation in natural level. The applied equipments and devices ensure the measurement of dose and dose rate in wide range, nuclide specific activity concentration of ground deposition and in air /with special attention to iodine in aerosol and vaporous forms/ as well as in samples of soil, water, vegetation, food-stuffs, etc. The measured data are handled, evaluated and recorded by an on board computer which provides also rapid information for any further decision making or intervention.

INTRODUCTION

As a consequence of increased number of operating nuclear facilities, first of all nuclear power plants and the lessons drawn from the Chernobyl accident underlined the importance of establishing environmental monitoring systems for obtaining rapid information in accidental situation on the radiological conditions at the affected area and providing suitable data to the competent authorities for decision making. Mobile units suitable for monitoring radiological impact at any selected location in the field play an important role in emergency preparedness.

In Hungary the nuclear facilities at the Central Research Institute for Physics as well as the nuclear power plant at Paks necessitated the establishment of a mobile environmental monitoring unit as a part of the emergency preparedness programme. The main objective was to establish a mobile unit which is based on a reliable vehicle /preferably a cross-country car/ and is equipped with instruments and devices necessary for assessing environmental impact of a nuclear accident after initial information concerning the situation originating from the operators or from the early warning system becomes available. The requirement was also to provide measured data suitable for further decision making and intervention, if necessary. For better utilization the application field was intended to extend also for monitoring lower level of environmental radiation for instance from natural sources.

It has to be mentioned that the amount of financial support made available for this project was also a limiting factor in the selection of the vehicle and its instrumentation.

METHODS AND EQUIPMENTS

After careful survey of the offers of vehicles being potentially available considering prices, delivery conditions and other practical aspects a Volkswagen Transporter type four-wheel driven microbus was selected with enlarged inside dimensions. The car has been specially furnished for the given task facilitating the fixation and transportation of the necessary equipments and devices as well as to provide comfortable and practical conditions for different activities to be carried out in the vehicle.

The mobile laboratory has been prepared for the measurement of dose and dose rate in wide range, ground surface contamination, nuclide specific activity concentration in air /with special attention to iodine in aerosol, in elementary and organic vaporous form separately/ as well as in other samples like soil, water, vegetation, food-stuffs, etc. The following equipments are available for the measurements of the above quantities

- Dose, dose rate:
- High pressure ionization chamber
 - Portable dose rate meters/GM counters/
 - Portable TL reader with $\text{CaSO}_4/\text{Dy}/$ bulb dosimeters
 - Personal alarm monitors
 - HpGe gamma spectrometer for in situ nuclide specific dose rate measurement

- Ground contamination:
- Portable surface contamination monitor /GM-counter/
 - HpGe gamma spectrometer for in situ nuclide specific ground contamination monitoring

- Activity concentration in samples:
- Shielded HpGe gamma spectrometer for sample analysis
 - Shielded plastic beta-counter for samples of elementary and organic iodine from the air

The on board personal computer has multifunctional task namely it serves as a multichannel analyser for sample gamma spectrometry and as the central computer for spectrum evaluation as well as for data handling, recording, storing and searching. The computer also provides rapid information for the necessity of intervention. The scheme of the monitoring system can be seen in Fig. 1.

The mobile unit is equipped with a number of necessary devices like AC power generator, batteries, sampling devices and sample holders, tools for simple sample preparation, wireless communication system, etc.

The following equipments and methods applied in the mobile laboratory have been developed in our department

- Soil sampler,
- Aerosol and iodine sampler,
- PILLE portable TL reader with CaSO_4/Dy bulb dosimeters [1],
- G'PEAK WORKSHEET computer programme for gamma spectrum evaluation [2],
- Calculation method for determining activity distribution in the ground using only spectral information of in situ gamma spectra [3],
- Automatic evaluation of in situ gamma spectra,
- MOBSYS computer programme for unified handling, recording, storing and searching of all measured data.

The dose rate meters applied in the mobile unit enables to cover a measuring range from 10^{-9} to 5 Sv/h while in case of dose meters from 10^{-6} to 1 Sv

APPLICATIONS

The mobile laboratory plays an important role in the emergency preparedness programme in the country. There is no continuous inspection at present, however in case of emergency the mobile unit will be ready to start within a few hours and can act as an essential tool for surveying the radiation conditions in the intermediate phase of the accident.

The continuous preparedness of the equipments is ensured by their frequent use in the environmental laboratory after having been removed from the vehicle. The mobile unit is intended to be applied in normal situation also for different surveying programmes ensuring the proper use of equipments in field conditions and providing training for the staff.

The improvement of the methods applied and their regular control including participation in intercomparison exercises also in international level are regarded as a necessary and important part of the emergency preparedness. A meeting of several teams operating mobile units in the Central European region /Workshop on Mobile Laboratories for Monitoring Environmental Radiation, held in Faks, Hungary in the period 16-20 September 1991/ was organized to establish a cooperation between the participating institutions and to be a base of an international network to react in emergency.

REFERENCES

1. P.P. Szabó, I. Fehér, S. Demó, B. Szabó, J. Vágvölgyi: Dosimetrical properties of the portable, wide dose range TLD reader "PILLE". Rad. Prot. Dosimetry, 17 279 /1986/
2. P.Zombori: Application of G'Peak-Worksheet /a New Software for Gamma Spectrum Analysis/ in Environmental Monitoring /to be published/
3. P. Zombori, A. Andrásfi, I. Németh: A New Method for the Determination of Radionuclide Distribution in the Soil by In Situ Gamma-Ray Spectrometry /to be published/

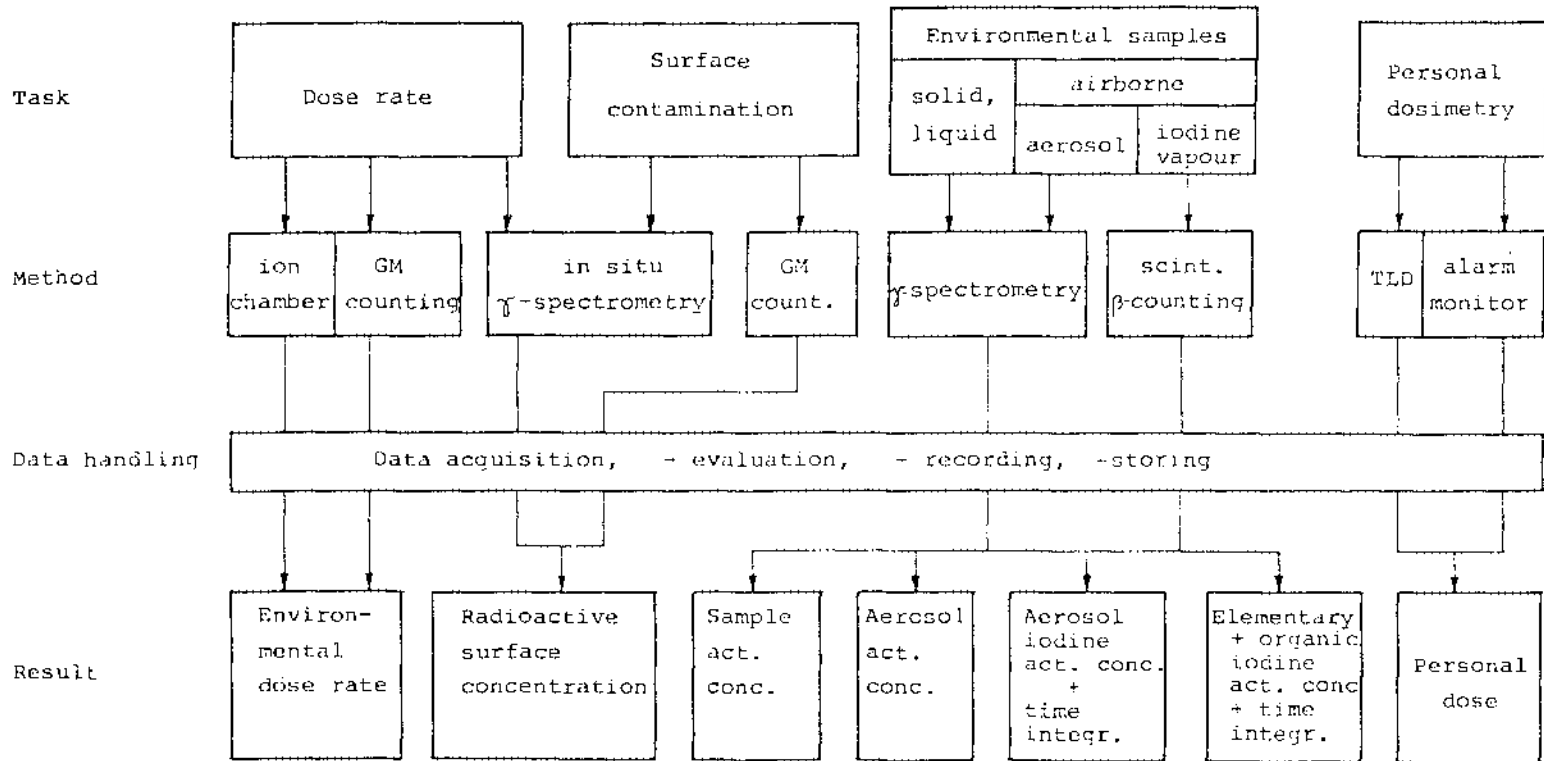

Fig. 1 Scheme of the monitoring system of the mobile unit

ETUDE EXPERIMENTALE DU LAVAGE PAR LA PLUIE DES IODES GAZEUX SUSCEPTIBLES
D'ETRE EMIS EN CONDITIONS ACCIDENTELLES

C.Caput, H. Camus, D. Gauthier et Y.Belot

CEA / Institut de Protection et de Sureté Nucléaire,
Département de Protection de l'Environnement et des Installations,
Centre d'Etudes Nucléaires de Fontenay-Aux-Roses,
BP N° 6, 92265 Fontenay-Aux-Roses Cedex
(Etude réalisée dans le cadre d'un protocole entre le CEA et EDF)

FIELD MEASUREMENTS OF THE WASHOUT COEFFICIENT FOR GAZEUS IODINE LIKELY TO
BE RELEASED ON ACCIDENTAL CONDITIONS

Field experiments were performed in Brittany to assess the washout coefficient A for molecular iodine. During each run, a few grams of nonradioactive iodine were released from a 12 meters telescopic mast, and the rain was sampled at a short distance downwind along complete transversal sections of the plume. The amount of iodine in each sample was determined by ionic chromatography to calculate the washout coefficient. In most cases, the results obtained (a few 10^{-5} s^{-1}) are not so different as expected from the theoretical values assuming a complete solubility of iodine in rain water.

INTRODUCTION

Les modèles prévisionnels de dispersion à la suite d'un rejet accidentel hypothétique utilisent habituellement pour caractériser le lavage des polluants par la pluie un paramètre A appelé coefficient de lavage. Ce paramètre, qui a la dimension de l'inverse d'un temps, représente la fraction du polluant entraînée par la pluie par unité de temps. Dans le cas de l'iode moléculaire, les valeurs de ce coefficient ont été établies de manière théorique, sur la base d'une entière solubilité de la vapeur d'iode dans les gouttes d'eau de pluie, ces dernières étant supposées se comporter comme autant de "puits" jamais saturés. Cette hypothèse théorique du gaz infiniment soluble dans l'eau de pluie peut, *a priori*, paraître exagérément majorante. En effet, le lavage par la pluie des gaz contenus dans l'atmosphère dépend de nombreux facteurs liés à la réversibilité des échanges entre phases gazeuse et liquide, aux mécanismes de mélange à l'intérieur des gouttes et aux réactions chimiques susceptibles de s'y produire. Dans le cas de l'iode moléculaire, les modèles prévisionnels actuellement utilisés dans l'hypothèse d'un accident admettent que le coefficient de distribution entre phases liquide et gazeuse est très faible (c'est à dire que les phénomènes de désorption sont négligés), ce qui autorise l'emploi du coefficient de lavage, paramètre d'une manipulation commode, mais pas nécessairement approprié pour autant lorsqu'il s'agit d'un gaz. Les modèles théoriques existants qui prennent en compte la réversibilité de l'absorption du gaz par les gouttes (Dana 1972, Hales 1973 et Kumar 1985) sont, quant à eux, trop complexes pour être utilisables dans le cadre de la prévision des conséquences d'un accident.

Par ailleurs, les seules mesures expérimentales existantes sont anciennes (Engelmann 1966), rares, et très dispersées. Elles ont été obtenues soit à partir d'une émission d'iode stable réalisée sur un pylône de 13 mètres (3 résultats), soit à partir des traces d'iode radioactif rejetées par la

cheminée d'une installation. Dans le premier cas, les valeurs du coefficient de lavage obtenues étaient comprises entre quelques 10^{-7} et quelques 10^{-6} s^{-1} , c'est à dire 1 à 2 ordres de grandeur au dessous des valeurs théoriques basées sur une entière solubilité de l'iode et correspondant aux mêmes intensités de précipitation. Dans le second cas, les résultats étaient supérieurs d'un ou deux ordres de grandeur à ces mêmes valeurs théoriques, ce qui, selon l'auteur, pourrait être dû à une captation de la vapeur d'iode sur les gouttelettes formées par condensation de la vapeur d'eau au niveau du conduit de rejet.

De nouvelles expériences *in situ*, du même type que celles réalisées en 1966 par Engelmann, mais bénéficiant des nouvelles possibilités techniques, en particulier en matière de dosage de l'iode dans l'eau, ont été réalisées par notre Laboratoire en Bretagne en 1990 et 1991.

METHODES EXPERIMENTALES

En présence de différents types de précipitations, une quantité connue (Q) d'iode stable (quelques grammes) est injectée dans l'atmosphère par un dispositif d'émission produisant de l'iode moléculaire par sublimation de paillettes. L'eau de pluie est échantillonnée sous le vent de l'émission à l'aide de collecteurs de précipitations disposés en arc de cercle de manière à englober l'ensemble de la largeur du panache, et au vent de l'émission pour déterminer la concentration naturelle en iode de l'eau de pluie. A l'issue de l'essai, les volumes d'eau (v) collectés en chaque point sont mesurés et, après filtration des échantillons sur filtres Millipore de porosité $0,45 \mu\text{m}$, les concentrations (C) en iode sont déterminées par chromatographie d'ions associée à une détection électrochimique (système Dionex), ce qui autorise une sensibilité meilleure que un ppb. Le principe de cet appareil consiste à faire circuler un échantillon de 5 ml à travers une colonne de préconcentration et à balayer cette dernière par un éluant qui entraîne l'iode vers la colonne de chromatographie. On en déduit les quantités d'iode (q) précipitées en chaque point d'échantillonnage: $q = Cv$. Lors de chaque expérience, la vitesse du vent (u) au niveau du panache, l'intensité de la pluie, son pH et sa température sont mesurés, ainsi que le spectre dimensionnel des gouttes.

Pour toute section transversale complète du panache de longueur L on peut calculer le coefficient de lavage Λ par la relation:

$$\Lambda = Wm(x) L u / Q$$

W m(x) étant la quantité moyenne d'iode déposée par unité de surface sur la bande de sol de largeur dx située à la distance x de la source et englobant la largeur totale L du panache, quantité déterminée à partir des dépôts q déterminés en chaque point d'échantillonnage du transect et connaissant la surface d'interception des collecteurs.

DEROULEMENT DES ESSAIS ET RESULTATS

Onze mesures du coefficient de lavage ont été effectuées: 3 en Octobre 1990 et 8 en Juillet 1991, (les conditions expérimentales et résultats donnés en tableau 1). Les intensités de précipitation (0,9 à 4,8 mm/h) et les vitesses de vent (2,5 à 18,3 m/s) sont représentatives des conditions les plus fréquentes sous nos latitudes. Les concentrations de l'eau de pluie en iode dans l'axe du panache doivent suffisamment dépasser le bruit de fond de l'eau de pluie pour autoriser la mesure, sans toutefois risquer de perturber le mécanisme de captation par les gouttes. Les valeurs du coefficient de lavage obtenues sont en moyenne légèrement plus élevées lorsque la concentration de l'iode dans l'eau de pluie est très

faible . Ceci nous conduit à étudier des concentrations de quelques dixièmes de ppb (la durée des essais est d'une heure), ou d'une dizaine de ppb (la durée des essais est alors réduite à 2 minutes). Le coefficient de lavage est en moyenne de $5,6 \cdot 10^{-5} \text{ s}^{-1}$ dans le premier cas au lieu de $3,1 \cdot 10^{-5} \text{ s}^{-1}$ dans le second. Il est à noter que les concentrations moyennes indiquées dans le tableau 1 sont relatives non pas à l'eau de pluie ayant traversé le panache, mais aux échantillons tels qu'ils sont collectés, plus ou moins dilués en fonction des conditions expérimentales par de l'eau de pluie reçue avant et après le passage du panache. Aucune corrélation claire n'a pu être établie entre le coefficient de lavage de l'iode et l'intensité, le pH ou la température des précipitations.

Dans le cas d'intensités de précipitation élevées, les valeurs expérimentales présentées ici sont sensiblement plus faibles que les valeurs théoriques se fondant sur un lavage irréversible (Fig.1). Par contre, dans le cas d'intensités modérées, les résultats expérimentaux obtenus peuvent, compte tenu des incertitudes expérimentales, être considérés comme une validation du calcul prévisionnel actuellement employé dans l'hypothèse d'un rejet accidentel.

Des expériences complémentaires ont montré que lors d'essais de ce type, il convenait de s'assurer que le panache ne venait pas au contact des collecteurs de précipitation, la forte réactivité de l'iode moléculaire provoquant alors un dépôt sec très important venant masquer celui entraîné par la pluie.

CONCLUSION

Dans le cas d'intensités de précipitation inférieures à 3 mm/h (fréquent sous nos latitudes) , et lorsque la concentration d'iode dans l'eau de pluie demeure très proche de la concentration naturelle préexistante, ce qui est toujours le cas dans le panache d'un rejet radioactif, les résultats expérimentaux obtenus sont peu éloignés des valeurs du coefficient de lavage adoptées dans les modèles théoriques supposant une entière solubilité de l'iode dans l'eau de pluie. Ces dernières apparaissent par contre un peu trop élevées dans le cas d'intensités de précipitation importantes.

REFERENCES BIBLIOGRAPHIQUES

- Dana M.T., Hales J.M. and Wolf M.A. (1972) "Natural precipitation washout of sulfur dioxide". Report to Div. Meteorol. EPA Contract BNW-389.
- Engelmann R.J., Perkins R.W., Hagen D.I. and Haller W.A. (1966) "Washout coefficients for selected gases and particulates" BNWL-SA-657. 59th An. meet. of the air poll. Contr. Assoc., San Francisco, June 20-24, 1966.
- Hales J.M., Wolf M.A. and Dana M.T. (1973) "A linear model for predicting the washout of pollutant gases from industrial plumes" Am. Inst. Chem. Engrs J., 19, 292.
- Kumar S. (1985) "An Eulerian model for scavenging of pollutants by raindrops" Atm. Env., 19, 769-778.

Tableau 1: LAVAGE DE L'IODE MOLECULAIRE PAR LES PRECIPITATIONS
 SITE DE ROC'H-TREDUDON (1990-1991)
 (Conditions expérimentales et résultats)

N°	u m/s	i mm/h	Larg. m	C moy ppb	vol moy. ml	Q g	A $10^{-5} s^{-1}$
1	15	1,3	34	10,77	4,4	20	2,5
2	9	4,8	24	5,16	25,2	10	7,4
3	8	3,3	40	5,97	9,8	20	2,5
4	15,5	1,2	28	0,65	38	5	5,4
5	15,5	1,2	19,2	0,33	40,5	5	2,0
6	8	0,9	28	1,52	46	5	7,8
7	8	0,9	15,6	0,45	48,1	5	1,6
8	18,3	1,7	14,4	0,76	74,1	4,5	8,2
9	18,3	1,7	23,6	0,62	64,9	4,5	8,4
10	3,0	4,0	30,8	3,46	24	10	1,9
11	3,0	4,0	28	2,37	28,3	10	1,4

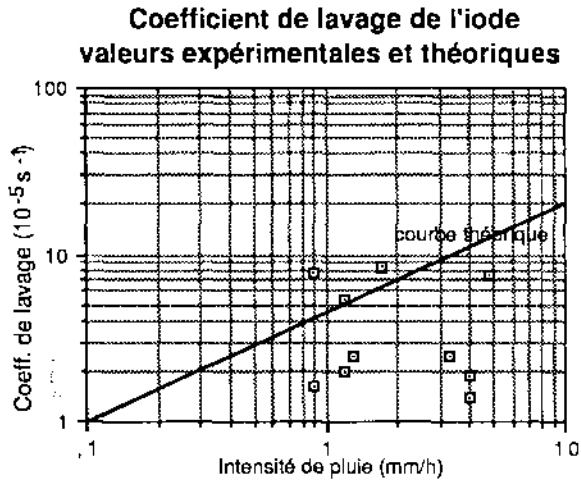

**GREEN BELT TO REDUCE CONSEQUENCES
OF REACTOR ACCIDENTS**

V.K. Gupta and Ramesh K. Kapoor
Atomic Energy Regulatory Board
Bombay-400 094

ABSTRACT

Airborne particulate activity has high deposition velocity on grass and crops. Green trees provide very high surface area per unit volume of space. A green belt, made up of optimally spaced and selected variety of evergreen trees, can, therefore, be utilized to reduce consequences of accidents in nuclear power plants, when release of radioactive materials is at ground level. Consequences of reactor accidents giving rise to ground level release in presence of a green belt in public domain are reduced by orders of magnitude. This may help reducing magnitude of emergency preparedness planning in public domain.

INTRODUCTION

Society and individuals are subjected to a variety of risks, both natural and technological. High probability-low consequence events do not attract as much public attention as low probability-high consequence events. Since it is difficult to modify probability of natural low frequency-high consequence events, society and individuals adopt various means of reducing consequences of these events such as construction of dams for reducing consequences of floods (1). Reduction of probability of high consequence events of man-made hazards such as in commercial aviation and nuclear power industry is achieved through engineering innovations. Nevertheless low probability-high consequence events in nuclear power industry have attracted special attention of individuals and society. A green belt around a nuclear power plant substantially reduces quantity of particulate radioactive material reaching public domain. Radiation exposure to population and early and continued mortalities for a hypothetical accident resulting in large, cold, ground level release of radionuclides for a light water reactor of 1000 MWe output shows fatality upto 13 km without green belt. This distance reduces to 2 km with a green belt.

ATTENUATION MODEL FOR GREEN BELT

Pollution attenuation factor, A_f of a green belt for ground level release is given by Kapoor and Gupta (2) :

$$A_f = \frac{F_D(X_1 + X_2)}{F_D(X_1) \{ \text{erf} \{ h_e / \sqrt{2} \sigma_z(X_1) \} e^{-\lambda X_1} + \text{erfc} \{ h_e / \sqrt{2} \sigma_z(X_1) \} F_D(X_2) \}} \quad \text{---(1)}$$

Schematic of a green belt of height h and width X_2 at a distance X_1 from nuclear power plant is shown in Fig. 1. Effective height h_e , and pollution attenuation coefficient λ are obtained from reference (2), $\sigma_z(X_1)$ is computed using relationship given by Hosker (3) and F_D is obtained from reference (4). V_d for particulate radionuclides is 0.01ms^{-1} and zero for noble gases. A_f are computed using Eq.(1) for 0.7, 1.0 and 1.5 Km wide

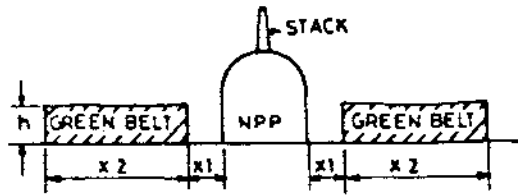

Fig.1 Schematic of a green belt around a nuclear power plant.

green belt of height 15 m consisting of pine trees planted at 50 m away from nuclear power plant(5).

DOSE EVALUATION FROM ATMOSPHERIC RELEASES

Released radionuclides, their inventory in reactor core and release fractions are taken as maximum of all release categories of light water reactor accidents (6). These are divided into volatiles and solids and noble gases due to their characteristic deposition velocities. Radioactive plume, emerging out of containment is dispersed by atmospheric turbulence and is carried away from site by wind. Given a reactor site and an accident starting time, which in turn specify atmospheric stability category and wind speed, concentrations of released radioactivity are calculated at the midpoint of chosen spatial interval and are assumed to be uniform within the interval. Buildings and structures of nuclear power plant would produce increased turbulence in near vicinity giving time integrated concentration \bar{X} as follows:

$$\bar{X} = \frac{Q}{(1.5 \sqrt{2\pi} \sigma_y \sigma_z + c.A) \bar{U}} \quad \text{----- (2)}$$

Q is source term, \bar{U} is mean wind speed and σ_y and σ_z are calculated using reference (3) for $z_0 = 0.01$ m. Vertical spread of plume is limited by the height of mixing layer L. c and A are assumed to be 0.5 and 2500 m² respectively. Plume gets depleted due to (i) radioactive decay of radionuclides and (ii) ground deposition. Plume depletion due to radioactive decay is considered only for decay of the parent nuclide and its depletion due to ground deposition is calculated using reference (4).

EXPOSURE PATHWAYS AND CALCULATION OF DOSES

Methodology of WASH-1400 (6) for assessment of doses to various body organs is used considering exposures through external exposure due to plume; internal exposure due to inhaled radionuclides and external exposure due to contaminated ground. Doses are calculated for all the 54 radionuclides individually and are added for each of the three pathways for bone marrow, GI tract, lung and thyroid using scheme of reference(6).

Green belt around nuclear power plant modifies concentration of released particulate radionuclides. Modified concentration \bar{X}_m for distances beyond green belt is obtained by dividing \bar{X} by A_f . Doses in presence of green belt around nuclear power plant are obtained using modified concentration \bar{X}_m for particulate radionuclides. Green belt does not modify

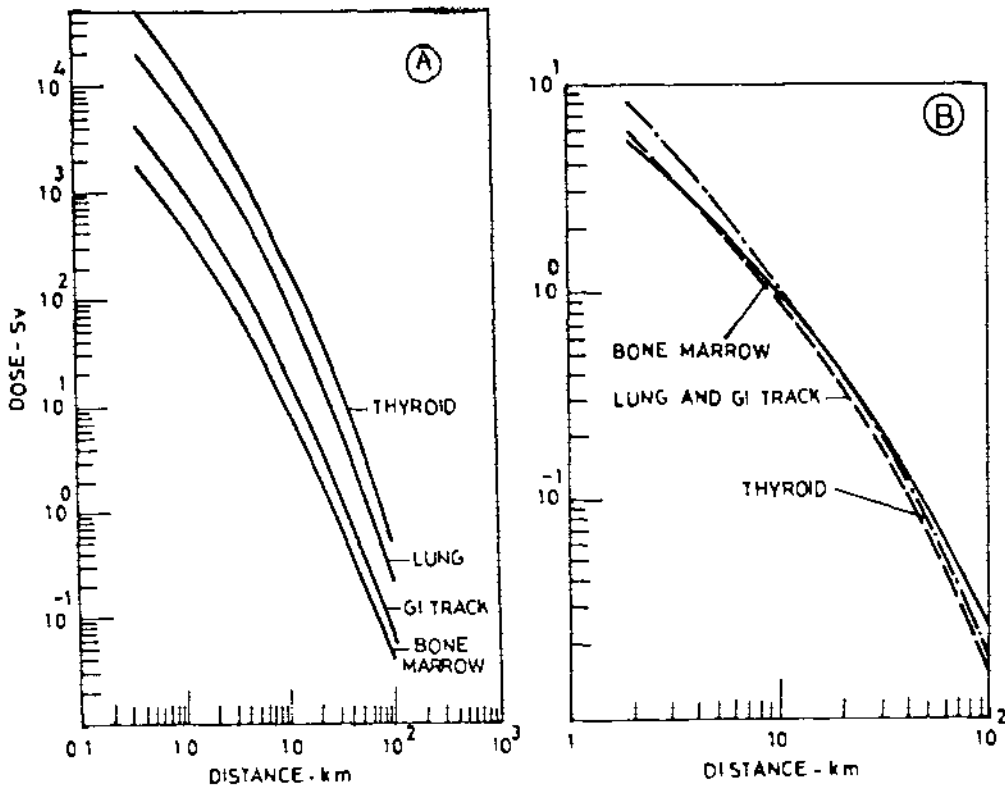

Fig.2 : Organ doses versus distance from nuclear power plant for stability category F (A-Without green belt,B- with green belt).

X for fission product noble gases as $V_d = 0$. Calculations are performed for all six stability categories. Results are presented for category F.

RESULTS AND DISCUSSION

Variation of doses without and with green belt of width 1.5 Km to bone marrow, lung, GI tract and thyroid with distance for stability category F is presented in figures 2 A and B respectively. The reduction factor of dose to bone marrow, obtained by comparing figures 2 A and B, is 40 at 2.0 km distance. This is less than A_f since only particulate radionuclides are attenuated by green belt. Radiation exposure to bone marrow is the dominant risk of mortality. Impact of green belt on early and continued mortalities due to bone marrow exposure is presented in figure 3, where variation of mortality probability with distance from nuclear power plant for atmospheric stability category F, without and with green belt of width 1.5 Km is presented. It is seen that mortality probability is one upto a distance of about 12 km without green belt and is about 0.5 at 2 Km and at 3 km it is almost zero with green belt around nuclear power plant.

CONCLUDING REMARKS

Benefits of developing a suitability designed green belt around nuclear power plants are:

THE RADIATION RISKS OF THE ACCIDENT SPECTRUM OF THE
GREEK RESEARCH REACTOR

J.G. Kollas

Inst. of Nuclear Technology and Radiation Protection
N.C.S.R. "Demokritos"
153 10 Aghia Paraskevi, Attiki, Greece

ABSTRACT

The Greek Research Reactor is a 5MW swimming pool type reactor located within the Athens area, a large population center of 3081000 inhabitants. The consequence analysis of the reactor focuses on the risks stemming from reactivity, coolant flow blockage, and loss of coolant accidents. Individual doses are estimated to a distance of 20km from the reactor site. Collective exposure and latent health effects for the inhabitants of the region are also calculated.

INTRODUCTION

The Greek Research Reactor (GRR) is an open pool type, light water moderated and cooled reactor with MTR type fuel elements, currently fueled with enriched uranium, that contains about 93% of U-235. GRR is located on the edge of the Athens larger area, about 10km from the city center, an area that concentrates more than three millions inhabitants.

The safety analysis⁽¹⁾ of GRR is based on the study of its response to postulated disturbances in process variables, and to postulated malfunctions, equipment failures, and operator errors. Four general groups of accidents are considered in the safety analysis report, namely loss of flow accidents, reactivity accidents, loss of coolant accidents, and minor accidents. The accident consequence estimations were performed using a PC version of CRAC.IPTA, a code that is based on the CRAC2 code⁽²⁾.

THE ACCIDENT SPECTRUM OF GRR

The first category of accidents considered in the safety analysis of GRR, includes accidents that cause a decrease of the removal rate of the heat produced in the reactor, such as primary pump failures, valve failures, partial flow blockage to fuel assemblies, loss of flow in the secondary cooling system, etc. Of all the accidents in this group the one with the potentially worst consequences is a coolant flow blockage accident (CFBA), that would cause a 50% failure of six fuel elements⁽³⁾. The assumptions concerning the releases into the environment from this accident are the following⁽³⁾: (a) 100% of the noble gases, 50% of iodines, and 1% of all other fission products of the melted fuel are released into the pool water, (b) 100% of the noble gases, and 10% of the remaining fission products in the pool water are released into the reactor building, (c) 100% of the noble gases, 10% of iodines, and 5% of the particulates in the reactor building are released into the environment

through the system of absolute and activated charcoal filters, (d) the release to the environment occurs through the reactor stack with an effective height of 50m, and lasts for ten hours. Such an accident has already occurred in similar reactors, and it is considered as the most serious realistic accident that could potentially affect GRR.

The second group of accidents includes accidents that involve a sudden increase in reactivity, such as maximum startup accidents, reactivity insertion accidents, excursions following the decay of a Xe-135 transient, loading accidents, control rod failures, etc. The most serious accident in this category is the maximum reactivity insertion accident (MRIA), that would cause the melting of less than 2% of the reactor core. The assumptions concerning the associated release of radioactive substances into the environment are similar to those of the CFBA.

The third group includes accidents that cause a loss of coolant, that might occur after such events as the rupture of the pool wall, the failure of an experimental beam tube or the thermal column, and most importantly the rupture of the primary cooling system. This last case involving the guillotine break of the largest pipe of the primary system defines the design basis accident (DBA) of GRR, a postulated loss of coolant accident that limits the potential risk to the public from any credible accident and for which the engineered safety features of the reactor are designed. The following assumptions apply to the DBA⁽⁴⁾: (a) 20% of the reactor core melts, (b) 100% of the noble gases, 50% of iodines, and 1% of all other fission products of the melted core are released into the environment, (c) the release into the environment occurs through leaks in the reactor building at ground level.

The fourth category includes accidents that have a minor impact, and do not lead to substantial releases that would affect adversely the general public. Such accidents are a fuel element cladding failure, the loss of ventilation in beam tubes and thermal column, the loss of primary electric power, etc. Since the consequences of such accidents are trivial they are not considered in the analyses performed.

RADIATION RISKS

The spectrum of accidents of GRR is delineated, as far as the consequences to the Athens population are concerned, by the three accidents CFBA, MRJA, and DBA, that are representative of the first three categories described previously. These consequences stem from both early exposure, i.e. direct irradiation by the passing cloud, exposure from inhaled radionuclides, and exposure to radioactive material deposited onto the ground, and chronic exposure, i.e. long-term groundshine from contaminated ground and inhalation of resuspended particles. Individual doses and cancer risks are estimated to a distance of 20km from the reactor site. Collective exposure and latent health effects for the inhabitants of the region are also calculated. The results are presented as dose curves for exposed individuals vs. distance from the reactor, or as complementary cumulative

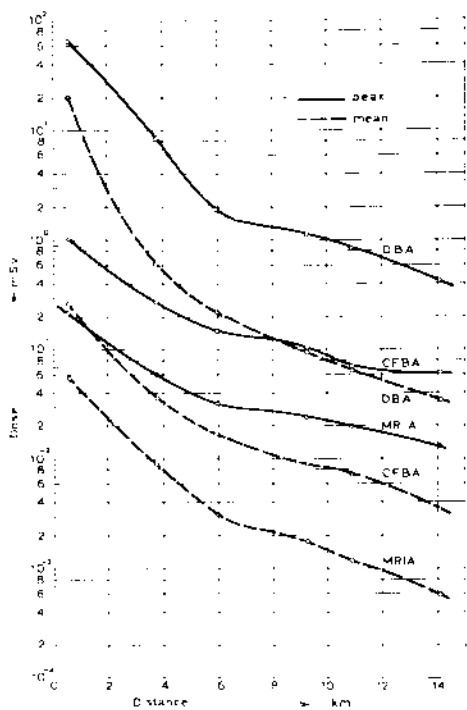

Fig 1 Acute Bone Marrow Dose vs Distance from Reactor

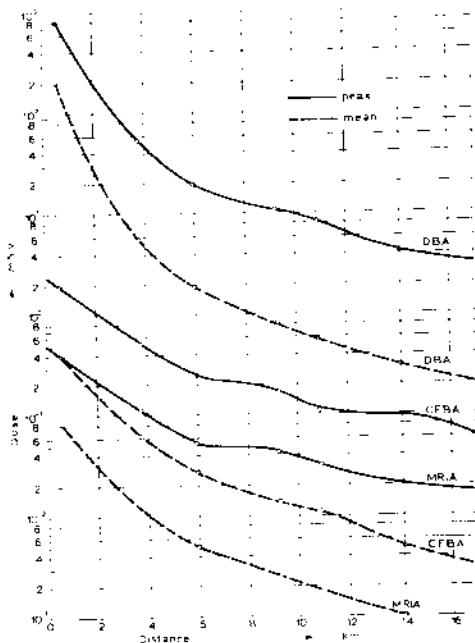

Fig 2 Acute Thyroid Dose vs Distance from Reactor

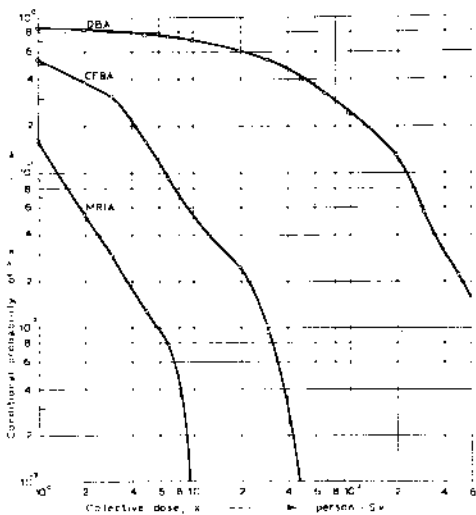

Fig 3 Whole Body Collective Dose CCDF

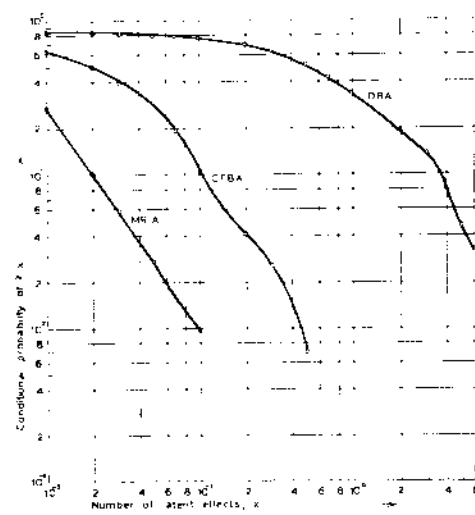

Fig 4 Whole Body Latent Effects CCDF

Table 1. Summary of number of latent effects - Total exposure

Effect	Mean Values			Peak Values		
	DBA	CFBA	MRIA	DBA	CFBA	MRIA
Whole body	1.28	0.0461	0.0092	20.5	0.864	0.180
Thyroid	37.2	0.289	0.0568	672	5.85	1.21
Leukemia	0.27	0.0093	0.0019	4.33	0.177	0.037
Lung	0.45	0.0084	0.0017	7.59	0.158	0.033
Breast	0.30	0.0112	0.0022	4.80	0.209	0.044
Bone	0.12	0.0037	0.0007	1.90	0.071	0.015
GI tract	0.10	0.0038	0.0008	1.63	0.070	0.015
Other	0.31	0.0113	0.0023	4.88	0.213	0.044
<u>WB collective exposure (Sv)</u>	81.1	2.92	0.582	1300	54.7	11.4

distribution functions (CCDFs) for collective exposure and health effects. The consequences of these accidents for the 3081000 inhabitants of the larger Athens area are presented in Figs. 1-4. Furthermore Table 1 presents a summary of the latent health effects that result from the total exposure of the Athens population.

CONCLUSIONS

The results presented in the previous section indicate that the consequences of the CFBA and the MRIA are negligible in comparison to the consequences of the DBA, being on the average about two orders of magnitude smaller.

It is important to note in Table 1 the small magnitude of the health effects associated with the realistic CFBA and MRIA, which amounts on the average to a very small fraction of an event, while even their peak values do not constitute any significant impact.

REFERENCES

1. Papastergiou, C., et. al., 1985, Safety Analysis Report of the Greek Research Reactor, GAEC Reactor Safety Committee.
2. Ritchie, L.T., et. al., 1983, Calculations of Reactor Accident Consequences, Version 2, (CRAC2): Computer Code User's Guide, NUREG/CR-2326.
3. Kollas, J.G. and Anoussis, J.N, 1986, An Assessment of the Consequences of a Research Reactor Credible Accident Release, Proc. 1Vth European Congress, XIIIth Regional Congress of IRPA, Salzburg, Austria, pp.162-66.
4. Kollas, J.G., The Dependence of the Risk of Research Reactors from Their Operating Schedule - A Case Study, Risk Analysis, 11, pp. 191-97.

HUMAN MILK RADIOACTIVE CONTAMINATION

S.Risica, G.Campos Venuti, A.Di Domenico, G.Grisanti,
L.Ragazzini(*), A.Rogani, F.Tancredi

Istituto Superiore di Sanità, Roma, Italy
(*) EEC fellow

ABSTRACT

Strontium 90 concentration in human breast milk - collected in Rome from May 1986 to December 1988 - was measured. The EPA recommended method was set up, with some modifications. Concentrations range from the lower limit of detection ($5-16 \text{ mBq}\cdot\text{kg}^{-1}$) to $58 \text{ mBq}\cdot\text{kg}^{-1}$. The committed effective dose from Sr-89 and Sr-90 to breast-fed infants, calculated utilising well-defined hypotheses, was in the order of $3 \mu\text{Sv}$.

INTRODUCTION

Research on radioactive caesium in human milk due to the Chernobyl fallout has been conducted in Italy since May 1986. Gamma spectroscopic measurements with high purity germanium detectors were made from May 1986 to December 1988 on pooled samples (from 5 to 10 nursing mothers in the first week after delivery)(1) and in 1989 on samples from individual women in a planned ad hoc study(2).

Caesium transfer factor from a mother's diet to her milk was assessed in both situations. The values agreed with the result obtained during the fallout period in the sixties - due to weapon tests - and with other values published after 1986 (see discussion in ref.2). Caesium 137 was studied in greater detail because in the post-Chernobyl environmental contamination of Western European countries it appeared at the time to be the most significant radionuclide(3).

On the other hand, strontium 90, the most significant radionuclide in the fallout period of the sixties, was fortunately quite low in the post-Chernobyl period: in Italy the Cs-137/Sr-90 ratio ranged from some hundreds to some tens. For this reason and because measurements are more complex and take more time, there is little environmental and human data available on strontium 90 after the Chernobyl accident. Therefore, in 1990 the authors decided to set up an experimental radiochemical procedure to measure strontium 90 concentration in the samples of human milk collected.

There were also other aims: i) to set up for the first time this experimental capacity in the Istituto Superiore di Sanità (National Institute of Health); ii) to gain experience in this experimental practice in order to promote it in environmental radioactivity laboratories set up in each Administrative District(4); iii) to evaluate the zero level of Sr-90 in human milk in case of possible future accidents.

EXPERIMENTAL METHOD

In order to separate Sr-90 in human milk samples the method recommended by the EPA(5) for milk was chosen. The method consists of fixing on a ionic exchange resin both strontium and barium present in human milk. Calcium in milk is first complexed with EDTA to avoid its taking the place of the two other chemical species on the resin. Both barium and strontium are removed by a concentrated solution of sodium chloride. The former is separated manually by taking advantage of its capacity to precipitate as a chromate. Strontium is recovered as a carbonate.

The method had to be adapted to 0.4-0.5 liter samples and in order to get good and reproducible yields, the following modifications to the original procedure were necessary.

i) The procedures require adjusting the milk pH value to 5.2, before fixing it on the ion exchange resin with ammonia. Samples studied always showed a lower acid content and therefore, the pH correction had to be made with acetic acid.

ii) The barium separation as chromate was repeated twice (instead of once) because in this way both a purer strontium carbonate and a higher yield of the Sr/Ba separation were obtained.

iii) The duration and velocity of centrifugation were increased: the former was doubled, the latter was changed from 2000 to 3000 r.p.m..

The improvements obtained by means of these modifications were tested with the atomic absorption spectrophotometry technique(6).

The Sr-90 measurements were taken with a gas flow α/β proportional counter with low background (<1 cpm), consisting of four detectors with ultra-thin windows ($260 \mu\text{g}/\text{cm}^2$), plus one guard detector, shielded by 10 cm of lead. The beta plateau is ≥ 200 volt with a slope $< 2.5\%$. The efficiency of the detectors was determined with Y-90 and Sr-90 filter sources, prepared with EPA methodology for standard sources, with the same geometry of the samples. The efficiency was found to be $> 45\%$ for Y-90 and $> 40\%$ for Sr-90. Both sources were monitored until Y-90 was either completely decayed or fully grown. On the Y-90 source this also permitted a check on the Sr/Y yield.

EXPERIMENTAL RESULTS

The filters obtained after the strontium separation in the samples were measured after having reached the Sr/Y equilibrium (that is after a minimum of 20 days). This allowed the filter to be counted over long periods (18-23 hours), thus reducing the high statistical error due to the very low activity of the samples.

The Sr-90 concentration in the pooled samples in the Rome area from May 1986 to December 1988 is shown in Figure 1. About 10 samples were found to be lower than or equal to the lower limit of detection(5) (in the range of $5-16 \text{ mBq}\cdot\text{kg}^{-1}$ depending on the experimental condition of each separation and count). The highest value was found in a 1986 sample equal to $58 \text{ mBq}\cdot\text{kg}^{-1}$. The concentrations are given as $\text{mBq}\cdot\text{kg}^{-1}$ because the determination of the sample weights could be made with a smaller error. However, the mean density of the samples resulted to be $1.02 \text{ kg}\cdot\text{l}^{-1}$.

It is not possible to know if the measured Sr-90 concentrations in human milk are due only to Chernobyl fallout, because no data was available on Sr-90 concentration in Italian human milk in the eighties before the accident. On the other hand, in the same years data was available on Sr-90 concentrations in cow's milk due to previous fallout.

The EPA radiochemical method also allows Sr-89 concentration to be determined by counting the filters a second time after 6-7 days. In this case, Sr-89 had already decayed due to the time that elapsed between sampling and counting.

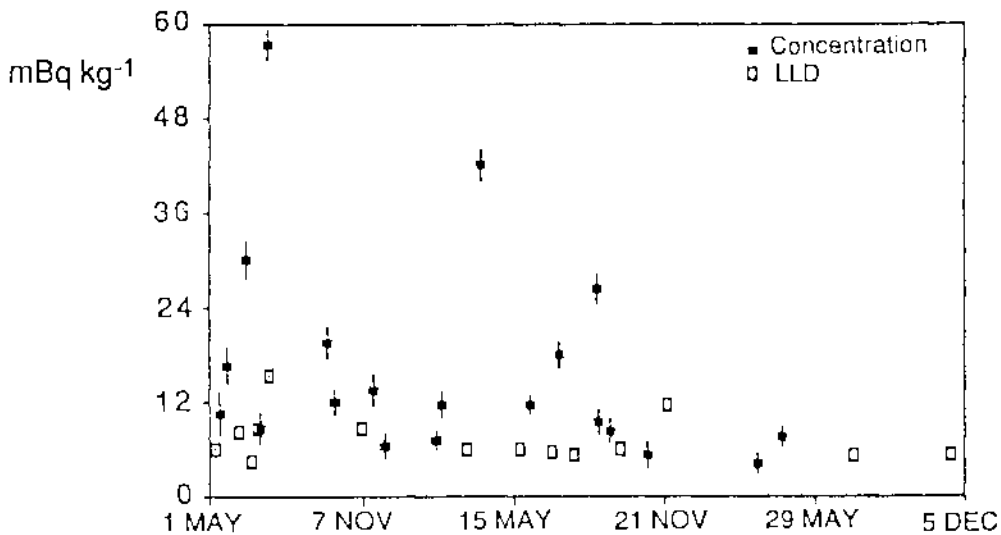

Fig.1 Sr-90 concentration in pooled breast milk samples from Rome over the period from May 1986 to December 1988. The measured values are given with one standard deviation, the LLDs at 95% C.L.

The dose from Sr-90 to breast-fed infants was calculated assuming a four-month breast-feeding duration and a milk ingestion rate of $0.7 \text{ l}\cdot\text{d}^{-1}$. Dose conversion factors calculated by the NRPB(7) in the light of the new ICRP Recommendations were used. Even if Sr-90 concentration had been constant for the first four months after the accident at the highest level measured, the committed equivalent dose to bone surface in the infant would have been equal to $14 \mu\text{Sv}$ and the committed effective dose to about $1.3 \mu\text{Sv}$.

In order to estimate the effective dose from Sr-89, the Sr-89/Sr-90 ratio was assumed equal to 10 as it ranged approximately from 15 to 5 in Italy during May 1986(8). In the same hypotheses used for the calculation of the dose from Sr-90, the committed effective dose to breast-fed infants from Sr-89 was assessed in the order of $1.5 \mu\text{Sv}$ in the first four months after the Chernobyl accident.

These doses are negligible and the effective doses are even lower than that previously calculated for Cs-137 in the same samples (see ref.1). Such low doses to infants could also be related to the ban on the consumption of cows' milk and leafy vegetables for pregnant and nursing women and children under ten imposed in Italy in May 1986.

Finally, by using the values of Cs-137 concentrations previously measured in the same samples(1), the Cs-137/Sr-90 ratio in 1986 was calculated. The range obtained for this ratio is compared with those measured in cow's milk in some Italian Districts(8,9) in Table 1.

Table 1. Strontium 90 concentration and Cs-137/Sr-90 in human milk and in cow's milk in some Italian Districts (1986).

District	Sample	Sr-90 (Bq.l ⁻¹)	Cs-137/Sr-90
Lazio(Rome area)	Human milk	<0.005-0.059	27-538
Lazio(Rome area)	Cow's milk	<0.05 -0.28	22-161
Lazio	Cow's milk	<0.05 -0.82	22-311
Piemonte	Cow's milk	0.09 - 2.4	4 - 246
Lombardia	Cow's milk	0.11- 0.79	109-146

REFERENCES

1. Campos Venuti, G., Risica, S. and Rogari, A., 1991, Radioactive Caesium Contamination in Human Milk in Italy after the Chernobyl Accident, *Radiation Protection Dosimetry*, 37, 1, 43-49.
2. Risica, S., Baronciani, D., Campos Venuti, G., Petrone, M. and Rogari, A., Caesium Contamination in Human Milk and Transfer Factor from Diet, in press in *The Analyst*.
3. UNSCEAR, 1988, Sources, Effects and Risks of Ionizing Radiation, United Nations, New York.
4. Campos Venuti, G., Monacelli, G., Piermattei, S., Risica, S. and Susanna, A., 1992, The Organization of Environmental Radioactivity Control in Italy, accepted at the IRPA8, Montréal, May 17-22, in press.
5. EPA, Eastern Environmental Radiation Facility, 1984, Radiochemistry Procedure Manual, Report EPA 520/5-84-C06.
6. Grisanti, G., Risica, S., Tancredi, F. and Ragazzini, L., Contaminazione Radioattiva del Latte Materno, in press in the Proceedings of the "4° Simposio sulle Metodologie Radiometriche e Radiochimiche nella Radioprotezione", Alghero, 10-13 Aprile 1991.
7. Phipps, A.W., Kendall, G.M., Stather, J.W. and Fell, T.P., 1991, Committed Equivalent Organ Doses and Committed Effective Doses from Intakes of Radionuclides. Chilton, NRPB-R245.
8. Ente Nazionale per l'Energia Nucleare e le Energie Alternative (ENEA), 1988, Misure Effettuate nell'anno 1986 dai Laboratori dell'ENEA su Campioni Ambientali e della Catena Alimentare in seguito all'Incidente di Chernobyl. Sez.1,5,6.
9. Cazzaniga, R., Dominici, G., Malvicini, A., Sangalli, E., 1987, Incidente Nucleare di Chernobyl, Aprile 1986. Ripercussioni sulla Catena Alimentare e sull'Uomo. Commissione delle Comunità Europee, Centro Comune di Ricerca di Ispra, EUR 11226 IT.

ACKNOWLEDGEMENTS

The authors are very grateful to D.Baronciani and M.Petrone of the Lecco Hospital for their collaboration in the study performed in 1989 and to C.Botsford for her patient support in the work on human milk. Thanks are also due to P.Di Ciaccio, G.Monteleone and M.Sabatini for their technical assistance.

This research is partially supported by the EEC contract BT6-0341-I(A) "Radionuclide transfer factor for human milk"

The Implication of ICRP Publication 60 for Nuclear Power Plants

R. Hock
Siemens AG, Offenbach, Germany

Abstract

The potential consequences of ICRP Publication 60 for the design and operation of nuclear power plants were investigated. Collective doses for plant personnel and maximum doses for members of the public are already so low particularly in plants of recent design that the increase in risk factors will not require additional protective measures according to the ALARA principle. The new limit for the individual occupational dose accumulated during 5 calendar years may require additional surveillance with respect to a few persons. The evaluation of the design of protection of the public against accidental exposures according to the new criteria needs further discussion.

ICRP Publication 60 contains a large number of basic changes in comparison to Publication 26. The most important change in principle is the requirement to include "probabilistic" exposures in the evaluation according to the three principles: justification, optimization and individual limits.

With respect to justification, this would require a new evaluation in which radiological hazards from planned operation and from potential accidents are both taken into account. By contrast, the optimization of protection against accidents and the not yet defined limits for the individual risk caused by potential accidents could be evaluated separately.

An upper bound for the occupational risk caused by accidental exposures can be estimated from operating experience. With respect to critical groups outside the plant (next neighbours) such data cannot be obtained from past experience. The existing methodologies used for probabilistic safety assessments have to be developed further to obtain such data. These can then specifically be used for the optimization of protective devices against accidents under the constraints of individual risk limits.

Whereas the extension of the radiation protection principles to include probabilistic exposures needs further methodological work the other changes contained in ICRP 60 brought can be applied immediately. The major ones of this category are the new risk factors and new individual limits with respect to normal plant operation.

If safety measures would be designed exactly to the optimum, increased risk factors would require additional measures according to the ALARA principle. Fortunately this is not the case. Older designs have been investigated many years ago and shown to be ALARA /1-4/. These analyses were based on much higher collective exposures than applicable today.

The trend of collective occupational exposure in nuclear power plants designed by SIEMENS is shown in Fig.1. Two conclusions can be drawn: Firstly, more recent designs feature much lower collective exposures and, secondly, at plants of older design - with generally higher collective exposures - exposures could be reduced by additional control and added protective devices. Any decrease in radiation exposure reduces the need for protection if the optimization criterion is applied. Therefore, a high degree of overprotection exists.

The influence of design improvements is shown even more clearly in Fig.2, where plants of the same size are compared on the basis of

their service lives.

It is evident that these improvements are much larger than the increase in risk factors from ICRP 26 to ICRP 60. We can conclude that despite the new risk factors we are still well on the safe side of the optimum. At this low level of exposure additional protective measures will have such a low return in terms of reduction of exposure that it is unlikely that even increased risk factors would balance out the cost.

The same is true with respect to collective exposures of the public. A measure for this exposure is the release of radioactive substances to the environment. As an example the radioactive liquid effluents (other than tritium) and the release of aerosols and gaseous iodine compounds are shown in Fig.3. The curves represent the overall tendency for the average of all plants built by SIEMENS. Individual plants sometimes deviate from that averaged long-term curves. In order to evaluate the safety margin with respect to the limits we calculated the hypothetical exposure of an individual assumed to stay permanently as a self-supplier at the most unfavourable location outside the plant boundary. A water flow rate which is typical for fairly small rivers at which some nuclear power stations are situated in Germany has been chosen for this evaluation. It turns out that the resulting exposure is below the new ICRP limits by several orders of magnitude. Additionally one has to keep in mind that the exposure of an average member of a critical group would be much lower than the exposure of the hypothetical person assumed for these calculations.

We have also evaluated the distribution of individual exposures of plant staff as a function of plant design and years of operation. An example of these evaluations is given in Fig.4 for a third generation BWR. Whereas the peak exposure has been one half of the limit for a single year in 1986 it decreased to only one fifth in 1990.

A more critical point is the new limit for five calendar years. Although this limit is not to be applied retrospectively a retrospective evaluation may show to what degree additional measures may be necessary in the future.

Figs.5 and 6 give examples of such evaluations: There is a limited number of people who may exceed the new limit in plants of older design, if no additional measures are taken. It is evident that the necessary reduction in peak individual dose is so low that it can be obtained by administrative means only. Job rotation will probably not even be necessary for the most exposed persons.

REFERENCES

1. Benassai, S., Bramati, L. 1983, Optimization of radiation protection in nuclear power plants in Italy. Second European scientific seminar held in Luxembourg Nov. 1983
2. Pepper, R.B., Dutton, L.M.C. 1983 The application of ALARA to the design and operation of the U.K. PWR. Second European scientific seminar held in Luxembourg Nov. 1983
3. Hock, R., 1983, Minimization of radiation exposures of members of the public by effluents from nuclear power stations built by KWU. Second European scientific seminar held in Luxembourg Nov. 1983
4. Hock, R., Hecht, G., 1983, Minimization of occupational radiation exposures in KWU-built nuclear power plants. Second European scientific seminar held in Luxembourg Nov. 1983

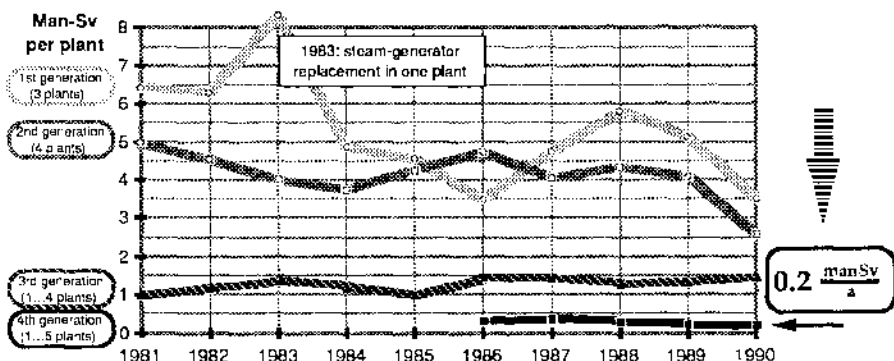

Fig.1 Influence of Design on Collective Dose (Siemens-built PWRs)

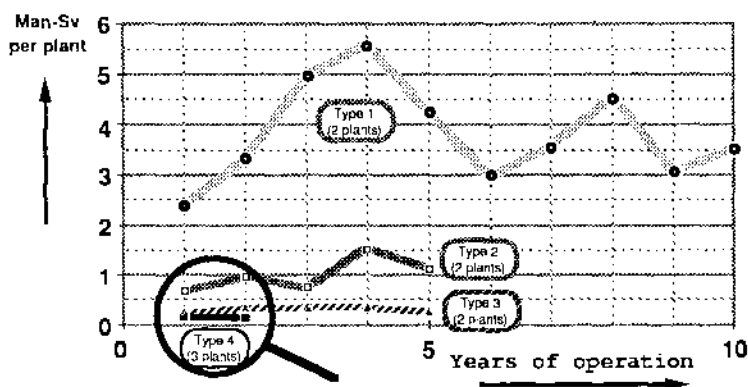

Fig.2 Influence of Plant Age on Collective Dose (1300 MWe PWR plants)

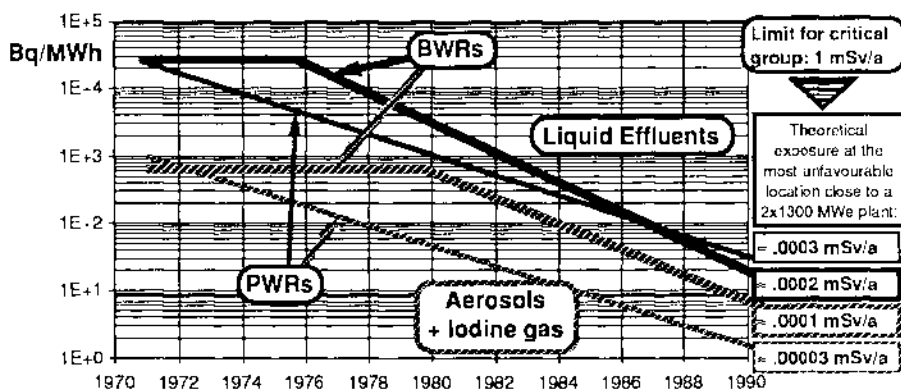

Fig.3 Release of Radioactive Substances to the Environment (Siemens-built plants)

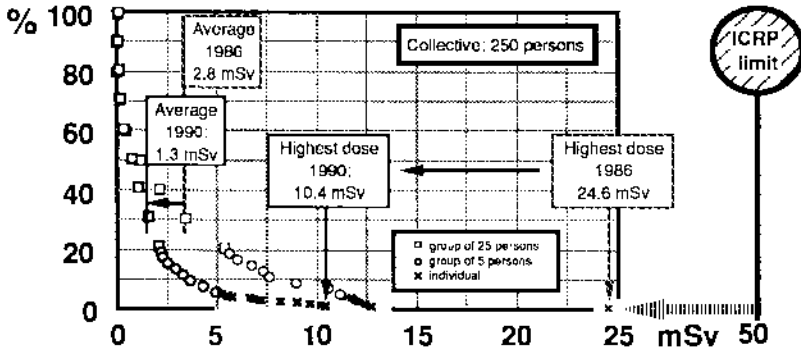

Fig. 4 Distribution of Individual Doses in One Calendar Year (3rd Generation BWR)

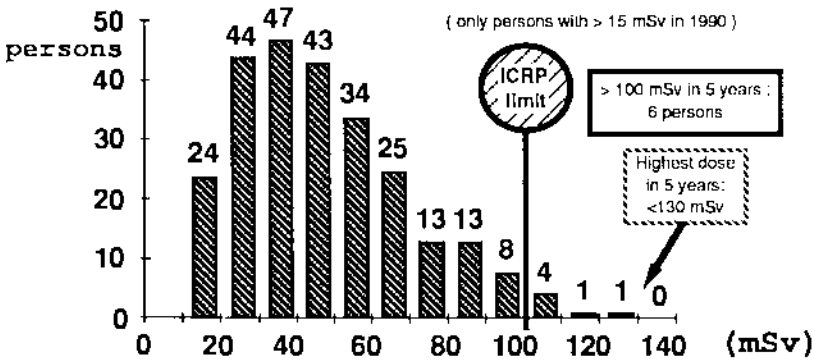

Fig. 5 Individual Doses within five Calendar Years of a Collective operating a number of PWRs

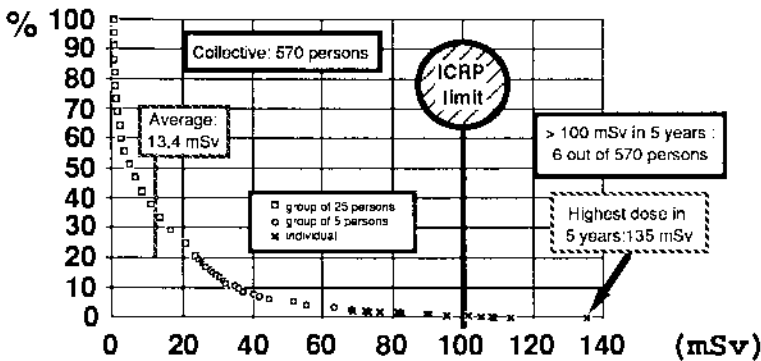

Fig. 6 Individual Doses within five Years (Siemens-built 2nd Generation PWR)

EVALUATION DE LA FAISABILITE DES MESURES DE PROTECTION ASSOCIEES A UN ACCIDENT DE TRANSPORT AERIEN DE PLUTONIUM

F. RANCILLAC*, P. PAGES*, J. LOMBARD** et Ph. HUBERT**.

*CEPN - BP n°48, 92263 Fontenay Aux Roses Cedex, France,

**CEA - BP n°6, 92265 Fontenay Aux Roses Cedex, France.

ASSESSMENT OF THE FEASIBILITY OF COUNTERMEASURES ASSOCIATED WITH THE RELEASE OF PLUTONIUM AFTER AN AIRCRAFT ACCIDENT.

SUMMARY

The air transport of radioactive materials has a very low accident risk (1000 times lower per kilometer than road) but potentially severe consequences. It is necessary to use reinforced packages. This communication examines the consequences of a severe accident to see what quantities released could be acceptably controlled. The example here is PuO₂ from reprocessed PWR fuel. Several criteria are taken into account (stochastic and non-stochastic effects, evacuation, decontamination). A value between 10 and 100 g of PuO₂ is the maximum limit for a "manageable" release. If a package has a capacity for greater quantities, more resistant packaging should be considered. The IAEA regulation is being modified ; the maximum considered quantity per package will be in the order of 20 g.

I INTRODUCTION

Le transport aérien des matières radioactives est l'objet d'un examen depuis cinq ans par l'Agence Internationale de l'Energie Atomique. La France a contribué à ce travail par la réalisation d'une étude [1] visant à savoir à partir de quelle quantité transportée un colis devrait répondre à des contraintes plus strictes que celles qui sont requises aujourd'hui. Le travail a consisté à passer en revue les divers types de conséquences d'un rejet et à juger à partir de quand la situation cessait d'être maîtrisable. Le produit étudié était le mélange d'oxyde de plutonium de retraitement.

II EVALUATION DES EFFETS SANITAIRES. L'IMPACT LIE A UN REJET ACCIDENTEL DE PuO₂

Partant d'un terme source lié à la défaillance mécanique ou thermique du colis, un modèle de diffusion atmosphérique a été utilisé pour évaluer l'impact sanitaire d'un rejet de PuO₂ suite à un accident d'avion. L'impact lié au passage de la bouffée initiale, et celui lié à la fraction déposée au sol ont été estimés séparément.

L'oxyde de plutonium considéré correspond au mélange isotopique issu du retraitement (combustible PWR irradié à 33 GWj/t, puis stocké 3 ans). Un pseudo "seuil de mortalité" doit être associé aux effets stochastiques dus à une incorporation de PuO₂ : 0,05 mg inhalé pour une poudre de 1 µm de diamètre ou 0,25 mg inhalé pour une poudre de 10 µm. L'équivalent de dose efficace engagé sur 50 ans est alors de 100 Sv; le dépassement de cette dose conduirait selon la CIPR [2] à une probabilité de décès par cancer radio-induit dépassant l'unité.

L'analyse des effets aigus lié à l'inhalation du plutonium a montré qu'ils ne se produisaient que pour des quantités inhalées supérieures au seuil précédemment indiqué, à savoir (pour une poudre de $1 \mu\text{m}$ de diamètre) :

1,8 mg inhalé : œdème pulmonaire en 1 mois

0,25 mg inhalé : fibrose entre 1 et 5 ans [3].

Ces quantités inhalées correspondent à des engagements de doses efficaces sur 50 ans de respectivement 3000 et 500 Sv.

Ces valeurs extrapolées de l'animal sont évidemment à considérer avec prudence. Pour fixer un ordre de grandeur, le seuil correspondant à l'apparition de fibroses a été retenu, ceci pour le passage de la bouffée atmosphérique. En supposant une densité de population autour de l'accident de 100 habitants par km^2 (valeur moyenne en France), on obtient alors les résultats indiqués sur le **tableau 1**. 1 kg de PuO_2 rejeté pourrait provoquer 5 fibroses pulmonaires.

Tableau 1 : Nombre de personnes susceptibles de présenter un effet aigu (fibrose pulmonaire) lors du passage de la bouffée initiale pour des conditions de diffusion normales et faibles (poudre de $1\mu\text{m}$).

Quantité rejetée (g)	Diffusion faible (vent= 1m/s)			Diffusion normale (vent= 1m/s)		
	Distance (m)	Surface (m^2)	Nombre de personnes	Distance (m)	Surface (m^2)	Nombre de personnes
10	25	210	ϵ	13	70	ϵ
50	73	1610	0,2	34	400	ϵ
100	115	3790	0,4	50	860	0,1
500	300	24400	2,4	130	4950	0,5
1000	430	50400	5	190	10500	1

Le délai de passage de la bouffée initiale est très bref. Ainsi, pour une vitesse de vent faible (1 m.s^{-1}) et un rejet de 100 g, les personnes exposées entre 50 et 500 mSv seraient touchées une demi-heure à une heure après l'accident, délai trop bref pour qu'une quelconque mesure puisse être prise, même le confinement.

Le risque d'inhalation lié à la bouffée initiale est le risque prépondérant, mais celui lié à la remise en suspension n'est pas négligeable pour un résident de la zone contaminée. Le risque d'ingestion lié à la contamination de la chaîne alimentaire reste faible au regard des deux précédents. Les hypothèses de calcul pour la contamination des aliments sont : une contamination du sol ($0,37 \cdot 10^6 \text{ Bq.m}^{-2}$), d'où proviendrait l'ensemble des aliments ingérés par une personne en une année.

La contamination du sol liée au dépôt a été estimée par le programme Batex [4]. Pour une vitesse de dépôt sec de 1 cm.s^{-1} et en l'absence de pluie, une quantité rejetée de 1 kg impliquerait une contamination du sol de $3,7 \cdot 10^6 \text{ Bq.m}^{-2}$ sur 8 km^2 ; de $0,37 \cdot 10^6 \text{ Bq.m}^{-2}$ sur 40 km^2 ; ... Le taux de remise en suspension retenu pour cette étude est celui estimé par le NRPB et repris par l'AIEA, soit 10^{-6} m^{-1} . Le **tableau 2** compare l'impact de chaque voie de transfert en prenant comme indicateur la surface à l'intérieur de laquelle les habitants auraient une dose d'au moins 50 mSv. Ainsi, pour une

densité de 100 hab.km⁻² et un rejet de 100 g, 700 personnes recevraient un engagement efficace de dose sur 50 ans supérieur à 50 mSv, dose uniquement liée au passage de la bouffée initiale. La remise en suspension seule n'impliquerait que 250 personnes à des doses supérieures à 50 mSv et la contamination par la chaîne alimentaire ne toucherait que 6 personnes à de telles doses.

Tableau 2 : Surfaces exposées à plus de 50 mSv pour chacune des voies de transfert, en fonction de la quantité rejetée.

Quantité rejetée (g)	Surface (km ²) exposée à une dose ≥ 50 mSv liée à :		
	bouffée initiale	chaîne alimentaire	remise en suspension
1	0,1	ε	ε
10	1	ε	0,3
100	7	0,06	2,5
1000	40	0,55	15

III LES MESURES DE PROTECTION

Le but des mesures de protection est de réduire les doses à la population. Certaines sont à court terme (évacuation, confinement, informations, ou conseils à la population). D'autres mesures à plus long terme visent la réhabilitation des sols (décapage, nettoyage, fixation des produits radioactifs, stockage,...). Pour la bouffée initiale, des mesures sont peu plausibles car il n'y a pas de délais d'alerte. Au vu des effets liés à la remise en suspension du PuO₂, des seuils de concentration ont été établis sur la base de la CIPR 40 [5] et du retour d'expérience d'accidents passés (comme celui de Palomarès). Les valeurs ci-dessous correspondent au centre de la fourchette recommandée par la CIPR (50 à 500 mSv pour l'évacuation). Le but de cette étude est en effet, non pas de définir une politique d'intervention, mais d'examiner l'ordre de grandeur des difficultés logistiques.

Pour la population :

- Evacuation au-delà de 7,4 10⁶ Bq.m⁻² (300mSv.an⁻¹)
- Confinement au-delà de 0,74 10⁶ Bq.m⁻² (30mSv.an⁻¹)
- Conseils à la population au-delà de 0,74 10⁴ Bq.m⁻²
- Rien en-deçà de 0,74 10⁴ Bq.m⁻² (0,3mSv.an⁻¹)

Pour l'environnement :

- Fixation et décapage au-delà de 0,74 10⁶ Bq.m⁻²
- Labour profond au-delà de 0,074 10⁶ Bq.m⁻²
- Rien en deçà de 0,074 10⁶ Bq.m⁻² (3mSv.an⁻¹)

L'application de ces mesures de protection entraîne des coûts, des doses aux intervenants, des quantités de déchets, ... Le **tableau 3** indique en fonction de la quantité rejetée, les surfaces atteintes et le volume des déchets associés. 1 kg de PuO₂ rejeté impliquerait 1,5 10⁶ m³ de déchets. Pour information, la capacité du site de stockage de Soulaines (France) est de 10⁶ m³.

Tableau 3 : Impacts liés à la restauration des sols.

Quantité relâchée dans l'atmosphère	Surface à décaper (5 cm d'épaisseur à retirer) km ²	Surface à traiter (lavage, épandage de produit piégeant le Pu) km ²	Volume de déchets (associés au décapage) m ³
1 g	0,06	0,5	3 10 ³
10 g	0,5	4,5	2,5 10 ⁴
100 g	4,5	25	2,5 10 ⁵
1000 g	25	90	1,5 10 ⁶

IV CONCLUSION

Afin d'augmenter l'efficacité de la mise en place des mesures de protection, il serait utile d'effectuer un suivi particulier de l'avion en cours de vol pour augmenter la rapidité d'intervention en cas d'accident.

Le réalisme du recours à des mesures de protection dépend étroitement de la quantité rejetée. Les effets aigus pour un rejet 1000 g resteraient limités. Des dépassements de dose de 0,5 Sv pourraient s'observer à partir d'un rejet de 1 g; pour 100 g plusieurs dizaines de personnes pourraient être concernées. Des évacuations de population pourraient avoir lieu à partir d'un rejet de 100 g, elles concerneraient alors une surface de l'ordre du km² ce qui semble encore gérable. La réhabilitation des sols pourrait demander quelques jours à quelques semaines pour un rejet de 10 g. A partir de 100 g de rejet, malgré un impact sanitaire limité, le volume des déchets est difficilement acceptable.

Compte tenu de ces valeurs, les résultats de l'étude montrent qu'un rejet maximal de 10 à 100g de PuO₂ apparaît comme gérable en zone rurale et juste tolérable en zone urbaine dans la mesure où les capacités logistiques risqueraient d'être saturées. A ce jour, l'AIEA a établi un projet de réglementation [6], le seuil retenu pour les colis renforcés (colis "C") a été fixé en termes génériques à une valeur qui correspond à une vingtaine de grammes de ce mélange.

REFERENCES

- [1] J. LOMBARD, P. HUBERT, P. PAGES : Analyse des événements consécutifs à un accident de transport aérien d'oxyde de plutonium. Rapport CEPN n°135, Paris 1988.
- [2] CIPR 30 : Limits for intakes of radionuclides by workers. Annals of the ICRP, Vol.2, n°3/4, Pergamon Press, 1979.
- [3] H. METIVIER : Aspects actuels du devenir biologique et de la toxicité du plutonium. In Journées d'études plutonium et radioprotection, Saclay, SFRP, juin 1983, pp. 21-39.
- [4] J.P. DEGRANGE, P. HUBERT, P. PAGES : BATEX, Guide de l'utilisateur version 1.2. Rapport CEPN n°117, juin 1987.
- [5] CIPR 40 : Protection of the public in the event of major radiation accidents: principles for planning. Annals of the ICRP, Vol.14, n°2, Pergamon Press, 1984.
- [6] F.W. COLLIN : "Mode-Related Aspects of the regulations for the safe transport of radioactive material". TC-675, (Report of the chairman, Mtg. Vienna, May 1990), IAEA, Vienna 1990.

FREE RADICAL MEASUREMENT IN BIO-ORGANIC SUBSTANCES USING AN ELECTRON SPIN RESONANCE TECHNIQUE

C.L. Greenstock and A. Trivedi
Health Sciences and Services Division, AECL Research
Chalk River Laboratories, Chalk River, Ontario, Canada

ABSTRACT

Electron spin resonance (ESR) is a simple, rapid and reliable method to measure absorbed doses in tissue-equivalent bio-organic substances, particularly amino acids and sugars or biological samples such as teeth, nails, hair and bone, as well as items of clothing, jewellery, medication or confectionery. In this capacity ESR represents a useful adjunct to existing dosimeters in cases of retrospective monitoring of radiation accidents, inadvertent radioactive releases or contamination and other emergency or operational situations. Studies have been performed to establish the dose and dose-rate responses, energy dependence, minimum detectable dose limit, post-irradiation stability of the ESR signal, and the practical limits of sensitivity, reproducibility and quantitation.

INTRODUCTION

Free radicals formed by irradiation are trapped in solids, and their number is proportional to the absorbed dose. ESR signals from bone, teeth, nails and hair have been used in biological dosimetry to estimate the absorbed dose in the human body, but poor sensitivity, stability and reproducibility have limited their application (1). An alternative approach is to study the ESR signals in tissue-equivalent substances or man-made items generally found associated with or in close proximity to humans, which can act as surrogates in emergency dosimetry for estimating human exposure (2). We have studied the ESR spectrometry of irradiated sugars and compared their response with other bio-organic substances and biological samples.

EXPERIMENTAL METHODS

Various irradiated samples (200-300 mg) were placed in a quartz tube (4 mm ID) and exposed to microwaves (10 mW power) at an X-band frequency (9.6 GHz) inside a microwave cavity between the poles of an electromagnet (330 mT field), in a Varian E-109 spectrometer, and the ESR spectrum determined by scanning over a field range of 3.3 ± 0.01 mT.

The ESR machine was calibrated daily against strong pitch, and the ESR signals from irradiated samples were measured against an internal reference spectrum of Mn^{2+} ($7.7 \mu\text{mol L}^{-1}$ solution sealed in a 1 mm ID quartz microtube). Signal strengths were determined either as peak-to-peak heights or as areas under the second-derivative curve, and

by taking the average of at least three measurements per experiment, an estimated precision of $\pm 10\%$ is obtained.

RESULTS AND DISCUSSION

Most forms of radiation dosimetry have limitations (3,4) for retrospective estimates of accidental (acute) or occupational (chronic) exposure. Biological and biochemical indicators (5) show some individual variability and fluctuations in the lack of a reliable base-line reference point prior to irradiation; most changes are short-term with indeterminate time-dependent responses. Cytogenetic methods are quite sensitive but require specially trained and highly skilled operators to perform the complex analyses (5).

The remaining methods are biophysical and include ESR dosimetry (1), lyo- and thermo-luminescence(6), spectrophotometry, densitometry and radiography (Table 1). Excluding LiF crystals and sensitive X-ray film, which would not normally be present at the scene of an accident prior to irradiation, emergency dosimetry must often rely on commonly available materials or readily obtainable biological samples, and ESR dosimetry is the only technique that can be used with such a wide range of materials (1,5).

Table 1: Biophysical Dosimetry

Sample	Method*	Dose Range Gy
Amino acids	ESR	1-10 ⁵
Sugars	ESR	1-10 ⁵
Amino acids	Lyoluminescence	10-10 ⁶
Sugars	Lyoluminescence	10-10 ⁶
LiF	Thermoluminescence	10 ⁻⁵ -10 ⁵
Plexiglass	Spectrophotometry	10 ³ -10 ⁶

* Precision $\pm 5\%$.

Biological samples suffer from irreproducibility, and consequently we have concentrated on universally available tissue-equivalent granulated table sugar (sucrose) as a suitable material (2). The ESR signals obtained following irradiation are simple, stable and reproducible, with a lower limit of detection of ~ 0.5 Gy, a linear dose response up to very high doses ($\geq 10^4$ Gy), independent of dose-rate and photon energy. This, combined with the universal application of ESR dosimetry to foodstuffs, human samples and bio-organic substances (Table 2), the ease of collecting and handling samples, their post-irradiation signal persistence and stability (Table 3), and the straight forward and rapid non-erasive measurement capability, make ESR a useful biophysical dosimeter for a variety of radiation applications including radiation processing,

polymerization and vulcanization of rubber, waste treatment, food irradiation, sterilization of medical supplies as well as for emergency dosimetry.

Table 2: ESR Signals from Irradiated Biological and Bio-organic Samples*

Category	Sample	Signal Intensity.g ⁻¹	Relative Sensitivity
Grains and spices	Flour-bleached	0.07	0.0
	Rye	3.70	0.05
	Wheat	4.35	0.05
	Popcorn	8.14	0.09
	Cinnamon	3.75	0.05
	Pepper-black	8.73	0.10
	Rice-long grain	6.69	0.07
Biological samples	Teeth-crushed	22.65	0.25
	Human finger nails	50.09	0.59
	Human Hair } black } grey	53.00 42.78	0.59 0.48
Bio-organic samples	Sugar-granulated	77.27	0.86
	RTV+ bound	89.89	1.00*
	Placebo	150.12	1.73
	Alanine-paraffin pellet	157.65	1.75

*10 Gy absorbed dose.

+Signal normalized to Dow Corning RTV Silicone pellets containing sucrose.

CONCLUSIONS

ESR spectrometry can be used as a biophysical dosimeter to measure absorbed doses ≥ 0.5 Gy in bio-organic substances (alanine, glucose) and biological samples (hair, nails). The ESR signals are directly proportional to absorbed dose, independent of dose-rate and photon energy (50-1250 kV), and stable for long periods after irradiation.

Table 3: ESR Dosimetry Using Biological and Biochemical Indicators.

Indicator System	Target Organs	Bioassay Site	Dose Range Gy	Time Period of Applicability After Exposure
Hair	whole-body partial body	hair	1 - 4	days/weeks
Nail	partial body	nail	1 - 4	days
Tooth	whole-body oral cavity	tooth enamel	0.5 - 5	years
Bone	whole-body	bone	0.5 - 5	years
Sugar Crystal	-	-	≥ 0.1	months
Organic Molecule (alanine)	-	-	≥ 0.1	months

REFERENCES

- 1 Dalgarno, B.G. and McClymont, J.D. (1989). Evaluation of ESR as a radiation accident dosimetry technique. *Appl. Radiat. Isot.* 40, 1013-1020.
- 2 Nakajima, T. (1982). The use of organic substances as emergency dosimeters. *Int. J. Appl. Radiat. Isot.* 33, 1077-1084.
- 3 Hashizume, T. and Maruyama, T.A. (1975). A review of thirty years study of Hiroshima and Nagasaki Atomic Bomb Survivors. *J. Radiat. Res.* 16, 12-23.
- 4 Balonov, M.I., Keirim-Markus, I.B., Margulis, U.Ya. and Osanov, D.P. (1989). Methods for retrospective determination of absorbed doses in the human body resulting from external and internal exposure. In "Medical Aspects of the Chernobyl Accident", International Atomic Energy Agency Report: TecDoc #516, pp 203-215.
- 5 Müller, W.U. and Streffer, C. (1991). Biological indicators for radiation damage. *Int. J. Radiat. Biol.* 59, 863-873.
- 6 Atari, N.A., Ettinger, K.V. and Fremlin, J.H. (1973). Lyoluminescence as a possible basis of radiation protection. *Radiat. Effects.* 17, 45-45.

LES COMPTEURS PROPORTIONNELS A MILIEU EQUIVALENT AU TISSU,
EN RADIOPROTECTION

Daniel Blanc et Pierre Ségur

Centre de Physique Atomique, URA 277,
Université Paul Sabatier, 31062 Toulouse Cedex, France

Jean Barthe et Jean-Marc Bordy

Service de dosimétrie, DPHD/IPSN/CEN
B. P. 6, 92265 Fontenay-aux-Roses Cedex, France

TISSUE EQUIVALENT PROPORTIONAL COUNTERS
IN HEALTH PHYSICS

ABSTRACT

The ICRP new standards put electronic dosimeters forward, especially in the case of neutrons. Proportional counters are an attractive solution : they are able to separate n doses and gamma doses and to give dose equivalents. The microscopic simulation of their gas gain makes it possible to achieve a global understanding of their mechanism. The main objective is to design an individual dosimeter. In this prospect, it is interesting to use a multicellular cathode in front of an anodic wire set, the expected sensitivity being 15 times higher as that of an ortho-cylindrical counter of a similar size. A monocellular prototype is in a preliminary step of development.

INTRODUCTION

Longtemps, la dosimétrie individuelle s'est satisfaite de dosimètres passifs. La situation était telle que les grands organismes de recherche diminuaient progressivement leurs travaux dans ce domaine, considéré comme au point. Le rapport ICRP n° 60 a bouleversé les données : le passage à 0,1 sievert pour cinq ans constitue une réduction des limites pour les travailleurs permanents (catégorie A) d'un facteur de 2,5 ; parallèlement, le facteur de qualité des neutrons est multiplié par un facteur 2 environ. Pour les neutrons, les limites actuelles de détection devront être réduites d'un facteur cinq et plus [1] : les dosimètres passifs sont d'une sensibilité insuffisante.

PROGRESSION DE LA DOSIMETRIE "ACTIVE"

Il faut se tourner vers les détecteurs électroniques. Ils sont employés depuis longtemps dans la surveillance de zone, mais la miniaturisation de l'électronique associée leur ouvre la voie de la dosimétrie individuelle. Deux systèmes sont en concurrence : les dosimètres électroniques à diode (par ex. la "DOSICARTE") et les compteurs proportionnels à milieu équivalent au tissu. Les domaines

d'emploi sont différents : la dosicarte excellerait pour les photons ; par contre, il sera difficile de discriminer la part des neutrons dans un bruit de fond gamma important. Par ailleurs la sensibilité aux neutrons est insuffisante.

INTERET DES COMPTEURS PROPORTIONNELS MICRODOSIMETRIQUES

a) Ils donnent le spectre différentiel de l'énergie linéaire $y(dy)$ en fonction de y (figure 1) : en fixant un seuil, on sépare ainsi les composantes neutrons et photons.
 b) On déduit d'un tel spectre le facteur de qualité moyen, donc l'équivalent de dose. En effet : $D = \int d(y)dy$, $d(y)$ étant la dose venant des particules dont l'énergie linéaire est comprise entre y et $y + dy$; $H = \int d(y)q(y)dy$, $q(y)$ étant identique à la courbe $q(L\infty)$ en identifiant y à L (transfert linéique d'énergie).

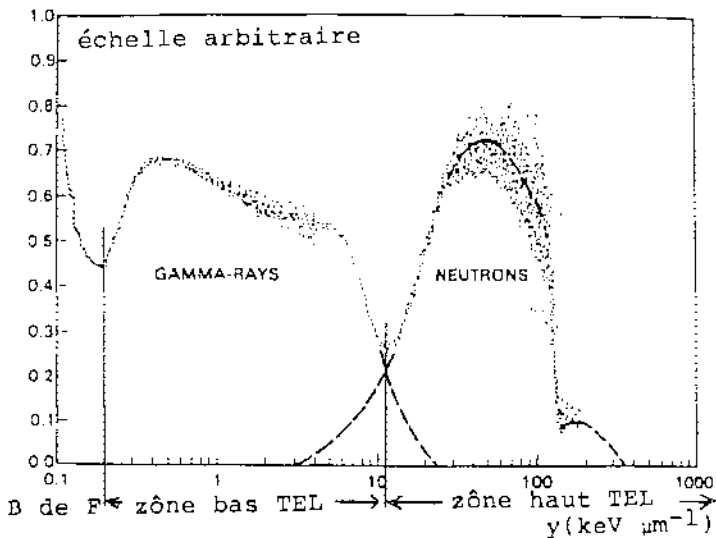

Figure 1 : Structure du spectre microdosimétrique $y(dy)$ en fonction de $\log y$ dans un champ mixte ($n + \gamma$).

LE PASSE : LA DOSIMETRIE DE ZONE

Les premiers compteurs équivalents au tissu biologique ont été réalisés par H. H. ROSSI [2]. On s'efforce de simplifier les structures et de rendre les résultats aussi reproductibles que possible. Il y a des réalisations industrielles, mais il s'agit toujours de compteurs de volume assez important, non portables. Le détecteur CIRCE (Fontenay-aux-Roses) pour le spatial est intéressant, mais d'un prix trop élevé pour la radioprotection.

LE PRESENT : SIMULATION COMPLETE DU GAIN DU COMPTEUR

Pendant longtemps, on a calculé le gain par des formules analytiques supposant une situation d'équilibre [2].

L'intervention d'un groupe spécialisé dans les décharges dans les gaz a permis une simulation microscopique précise dans une situation de non équilibre [3]. On domine totalement le fonctionnement des remplissages gazeux à base de méthane et de propane, entre autres.

L'AVENIR : LA REALISATION D'UN DOSIMETRE INDIVIDUEL

On sait réaliser le remplissage gazeux optimal. Reste la structure du détecteur lui-même. Des essais ont été effectués par la Société Merlin-Gérin ; le compteur de la figure 2 est un prototype de volume important ; les difficultés de passer à un petit volume se sont avérées redhibitoires [4].

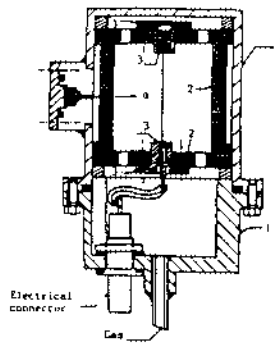

Figure 2 : Le compteur Merlin Gérin. Le volume sensible est un orthocylindre de 32,5 mm de diamètre. 1 : aluminium, 2 : plastique équivalent au tissu, 3 : isolant.

La réduction de sensibilité, accompagnant la réduction des dimensions conduit à envisager une géométrie plus complexe : il faut augmenter la surface d'échange entre les parois internes et le gaz ; on étudie un compteur multicellulaire dont la cathode est percée d'un grand nombre de canaux (figure 3) ; en face de chaque canal est tendu un fil anodique. Les canaux représentent une zone de dérive où le champ électrique (dirigé vers l'axe longitudinal du canal) est suffisant pour empêcher la recombinaison et guider les électrons vers l'anode, mais insuffisant pour provoquer une multiplication électronique. Les électrons qui émergent du canal sont accélérés dans le champ intense qui existe autour des fils anodiques.

On envisage de réaliser un compteur de $(12 \times 8 \times 3)$ cm³, ce qui est de l'ordre des dimensions d'une calculatrice de poche. Une cellule élémentaire (un canal, une anode) fonctionne actuellement et discrimine neutrons et photons. Par rapport à un compteur cylindrique de même volume, le gain de surface d'échange étant de quinze, le gain de sensibilité devrait être du même ordre de grandeur pour le compteur multicellulaire.

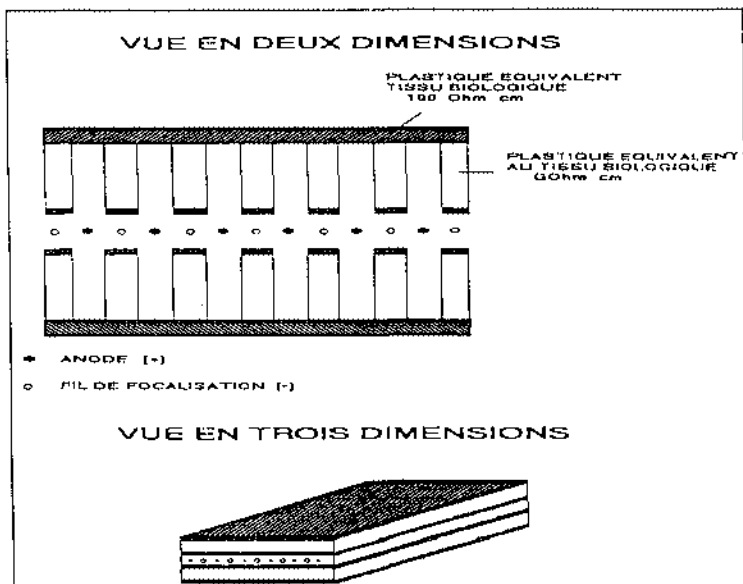

Figure 3 : Le compteur multicellulaire étudié par le S-DOS (Fontenay-aux-Roses).

CONCLUSION

Le problème du dosimètre individuel est difficile, même si la physique de son fonctionnement est bien connue. Deux points sont fondamentaux : 1) La réalisation d'un matériau équivalent au tissu de résistivité déterminée. 2) La pollution du gaz de remplissage (toute circulation de gaz était impossible) par une contamination venant des parois.

REFERENCES

1. Portal, G., 1991, Determination of dose equivalent resulting from neutron radiation in the light of the new ICRP recommendations, Seventh symposium on neutron dosimetry, Berlin.
2. Blanc, D., (avec Barthe, J., Buxerolles, M. et Portal, G.), 1990, Les rayonnements ionisants. Détection, spectrométrie, dosimétrie, Masson, Paris, pp. 142-151.
3. Ségur, P., Pérès, I., Boeuf, J.P. et Bordage, M.C., 1989, Microscopic calculation of the gas gain in cylindrical proportional counter, Radiation protection dosimetry, 23, 1/4, pp. 253-256.
4. Marchetto, A., Leroux, J.B., Herbaut, Y., Latu, M. et Tinelli, P., 1988, CIRCEG, a portable device for photon-neutron dosimetry, Radiation Protection Dosimetry, 23, 1/4, pp. 253-256.

**DESCRIPTION DE L'INSTRUMENT NAUSICAA CONCU POUR EFFECTUER
DES MESURES INSTANTANÉES DE D, H ET DU SPECTRE DE T.L.E.
EN CHAMPS COMPLEXES**

P. Bouisset, V.D. Nguyen, G. Kerlau, L. Lebaron, N. Parmentier
CEA/Institut de Protection et de Sécurité Nucléaire
Département de Protection de la santé de l'Homme et de
Dosimétrie, BP 06, 92265 FONTENAY AUX ROSES Cedex (France)

M. Siegrist - C.N.E.S, 31035 TOULOUSE Cedex (France)

L. Braak - MEDES, 31052 TOULOUSE Cedex (France)

B. Almarcha, E. Duvivier - STEEL, 31260 SALIES-DU-SALAT (France)

B. Weichlein, B. Masson - STATICE S.A, 25000 BESANCON (France)

NAUSICAA succède au système CIRCE. Il fonctionne avec un compteur proportionnel équivalent tissu suivant la technique microdosimétrique. En terme d'énergie linéique, il couvre une gamme de 0,3 à 1200 keV/ μ m dans le tissu et enregistre le spectre de TLE. Le débit de dose absorbée, entre 1 μ Gy/h et 20 mGy/h, ainsi que l'équivalent de dose associé sont mesurés en temps réel comme cela est nécessaire en radioprotection.

NAUSICAA est parfaitement adapté à la dosimétrie et à la radiobiologie spatiale où des événements de haut TLE, facteurs de qualité entre 10 et 20, peuvent être enregistrés.

**INSTRUMENT DESCRIPTION OF NAUSICAA USED FOR REAL TIME
MEASUREMENTS OF D, H AND L.E.T SPECTRUM IN COMPLEX FIELD**

The new instrument NAUSICAA is based on microdosimetric techniques using a low pressure tissue equivalent proportional counter. In terms of lineal energy, NAUSICAA device works in the 0.3 to 1200 keV/ μ m range in tissue and the LET spectrum is recorded. Absorbed dose rate, in the range of 1 μ Gy/h to 20 mGy/h, and dose equivalent rate are given in real time like it is necessary for radioprotection applications.

NAUSICAA is well adapted to space dosimetry and radiobiology where high LET events with quality factor in the range 10-20 are found.

INTRODUCTION

NAUSICAA est dérivé de l'appareil CIRCE. Ce dernier a été utilisé pour des mesures instantanées de dose absorbée et d'équivalent de dose, en décembre 1988, lors de la mission franco-soviétique à bord de la station orbitale MIR^(1,2).

La conception du nouvel instrument a été modifiée afin de tendre vers un système portatif utilisable au sol ou en vol. La fonction de l'appareil est d'obtenir des résultats rapides, lors de mesures dans un champ de rayonnement inconnu à faible débit de dose, tel qu'on souhaite le faire en radioprotection.

Pour répondre aux souhaits exprimés en radiobiologie, NAUSICAA fournit le spectre de transfert linéique d'énergie (TLE) associé à la mesure. Ceci permet, en particulier dans le cadre d'une application spatiale, de mettre en évidence la

présence de quelques particules (ions lourds) de TLE élevés, événements qui contribuent avec un poids important au facteur de qualité et à l'équivalent de dose.

DESCRIPTION DE NAUSICAA

Le capteur (Cf. Figure 1) est un compteur proportionnel cylindrique à champ axial dont les parois sont en équivalent tissu (E.T.). Le volume sensible (5 cm de diamètre x 5 cm de hauteur) est rempli de gaz E.T., à base de propane, sous faible pression (30 torr). On recueille ainsi l'énergie déposée par le rayonnement incident dans un site biologique d'une taille de $2 \mu\text{m}$ sous 1 cm de tissu.

Une mince enveloppe de 0,3 mm de Nickel constitue la paroi extérieure du capteur. Celle-ci assure la résistance mécanique et la parfaite étanchéité de la sonde.

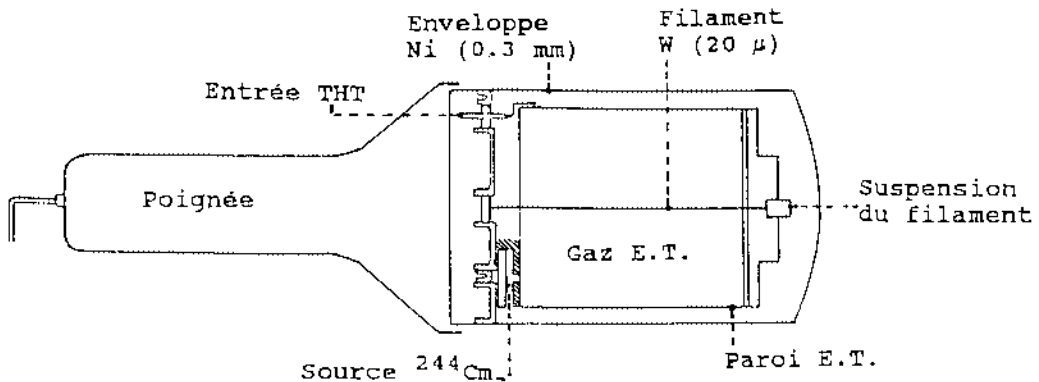

Figure 1 - Représentation schématique en coupe de la sonde.

Une source émetteur-alpha (^{244}Cm), placée au niveau de l'embase du capteur, peut être mise en position mesure. Elle permet de vérifier la valeur du gain gazeux et de modifier si nécessaire la valeur de la THT appliquée afin de compenser toute variation de ce gain.

Cette méthode assure la longévité et le parfait fonctionnement du système sans être contraint d'effectuer un nouvel étalonnage du capteur. Il suffit de quelques minutes pour réaliser ce contrôle et celui-ci peut être programmé pour avoir lieu automatiquement à intervalle de temps régulier.

L'appareil de mesure est constitué d'un boîtier contenant l'électronique du système et d'une sonde reliée à ce boîtier par un câble souple comme le montre la Figure 2.

Le signal issu de la sonde est transmis au boîtier par un câble. Ce câble transporte aussi la basse tension nécessaire au préamplificateur situé dans la poignée de la sonde.

Le boîtier, alimenté par une source extérieure en 27 volts continu, consomme 3 watts et pèse moins de 3 kg pour un encombrement de 230 mm x 160 mm x 130 mm.

Les grandeurs dosimétriques caractérisant le champ de rayonnement sont inscrites sur un affichage digital. Lorsque

le temps de la mesure est écoulé, ces grandeurs, ainsi que le spectre des impulsions, sont enregistrés sur mémoire de masse (EPROM ou disquette). Un logiciel installé sur PC permet ensuite la lecture et la mise en forme des résultats.

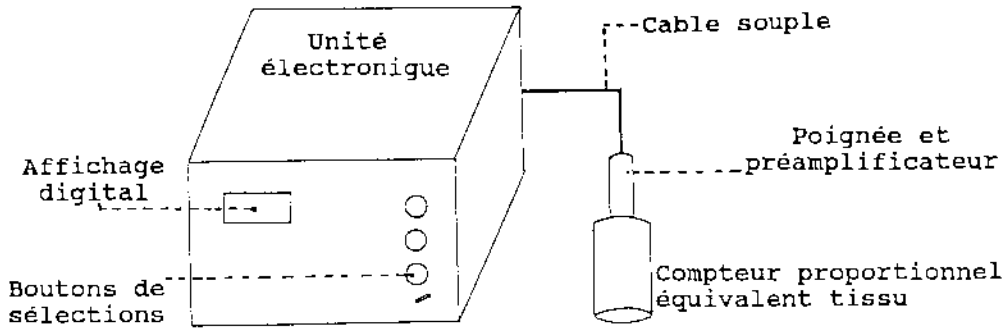

Figure 2 - L'appareil NAUSICAA est constitué d'une sonde et d'un boîtier, contenant l'électronique du système, où sont affichés instantanément les résultats.

PERFORMANCES ET RESULTATS EXPERIMENTAUX

Le capteur fonctionne en régime proportionnel. A chaque événement, traité individuellement⁽³⁾, est associé le facteur de qualité suivant la définition de l'ICRP 21⁽⁴⁾.

On recueille ainsi la fréquence des événements jusqu'à un taux de 10 kHz et on mesure le débit de dose absorbée dans la gamme 1 $\mu\text{Gy/h}$ à 20 mGy/h . Avec le facteur de qualité associé, entre 1 et 20, l'équivalent de dose est immédiatement calculé.

Le rapport H/D indiqué par l'appareil correspond alors au facteur de qualité moyen du champ de rayonnement⁽³⁾.

Une campagne de mesures a été menée auprès d'une source de ^{252}Cf de faible activité⁽⁵⁾. Les grandeurs mesurées sont comparées dans le Tableau 1 aux valeurs enregistrées avec des détecteurs thermoluminescents ($^7\text{Li}_2$ $^{11}\text{B}_4\text{O}_7$), insensibles aux neutrons, et aux valeurs obtenues avec des détecteurs à bulles⁽⁶⁾, insensibles au rayonnement gamma.

Mesure neutron BULLES H_n [$\mu\text{Sv/h}$]	Mesure totale neutron-gamma CIRCE-NAUSICAA H_t [$\mu\text{Sv/h}$] D_t [$\mu\text{Gy/h}$]	Mesure gamma TLD D_g [$\mu\text{Gy/h}$]
69.5 \pm 6.0	66.5 \pm 2.1 11.2 \pm 0.2	3.5 \pm 0.2

Tableau 1- Débits de doses enregistrés auprès d'une source de ^{252}Cf par différents systèmes de mesures.

Les résultats rapportés ici représentent la valeur moyenne et l'écart-type pour 7 mesures de 2 heures à une distance de 1,66m de la source. On remarque évidemment la cohérence des

résultats, en dose absorbée comme en équivalent de dose, mais on peut constater aussi, par la valeur de l'écart-type rapportée, la bonne reproductibilité de la mesure.

Puisque chaque événement est individualisé lors de l'acquisition des données, il est alors simple de construire la distribution de TLE mesurée. Les hauteurs d'impulsion sont converties et classées sur 256 canaux en couvrant une gamme de 0,3 à 1200 keV/ μ . Cette grande dynamique dans les hauteurs d'impulsion traitées est assurée par un amplificateur logarithmique situé dans le manche de la sonde en sortie du préamplificateur linéaire.

Les ions lourds, tels qu'on les rencontre dans l'espace, conduisent à des dépôts d'énergie dans le tissu bien supérieurs à celui des neutrons. Lorsqu'un événement de ce type se produit, superposé à un champ donnant de faibles TLE, l'équivalent de dose et le facteur de qualité moyen subissent une nette augmentation. Seule l'analyse détaillée des événements permet de définir la contribution des ions lourds.

Une première approche dans cet esprit a été effectuée sur la station orbitale MIR avec CIRCE. Pour cette expérience, des mesures d'une durée de 30 secondes seulement permettaient de faire apparaître des facteurs de qualité élevés car faiblement pondérés par les événements de bas TLE⁽²⁾.

NAUSICAA apportera des renseignements plus précis sur ces événements en fournissant le spectre de TLE : même s'il est unique, un événement sera ainsi répertorié.

CONCLUSION

NAUSICAA permet d'effectuer, en temps réel, une dosimétrie de zone en champs complexes (neutron-gamma-particules chargées). Les données obtenues sont la dose absorbée, l'équivalent de dose et le spectre de T.L.E. dans la gamme 0,3 à 1200 keV/ μ m.

Le capteur, organe délicat du système, est aujourd'hui parfaitement adapté à une utilisation de routine: résistances aux chocs (normes spatiales) et durée de vie de bon fonctionnement.

L'ensemble forme un système très performant pour des mesures dans l'espace où siègent de fortes variations spatiales et temporelles, variations en débit et variations en nature de rayonnement.

REFERENCES

- 1- V.D. Nguyen & al., Radia.Prot.Dosim.31(1), 377-382 (1990).
- 2- P. Bouisset & al., COSPAR 90, Adv.Space Res.(à paraître).
- 3- V.D. Nguyen & al., Radia.Prot.Dosim. 10(1), 277-282 (1985).
- 4- ICRP 21, Data for protection against ionizing radiation from external sources (1971).
- 5- G.Kerlau et P.Bouisset, Rapport DPHD (1991) (à paraître).
- 6- H. Ing & H.C. Birnboim, Nucl.Tracks & Rad.Meas.8(1-4), 285-288 (1984).

MEASUREMENT OF HTO PERMEABILITY OF MATERIALS
FOR PROTECTIVE APPLIANCES

Hideaki Yamamoto, Masashi Tomooka*, Shohei Kato, Mikio Murata,
Nobuyuki Kinouchi and Hozumu Yamamoto
Japan Atomic Energy Research Institute
Tokai-mura, Naka-gun, Ibaraki-ken, 319-11 Japan
*Koken Limited, 7, Yonban-cho, Chiyoda-ku, Tokyo, 120 Japan

ABSTRACT

Tritiated water (HTO) vapor permeabilities were measured for plastic and rubber films used for protective appliances (suits, gloves, wrappings, etc.). The measurement data prove that polyethylene and butyl rubbers are materials suitable for HTO protective appliances with their lower permeability. The data also indicate that desiccating protective appliances before reuse is effective for restoring their original resistances to penetrating HTO vapor when they are repeatedly used.

INTRODUCTION

Characterization of protective appliances for HTO vapor penetrating through those appliances has been a major subject in an effort at reducing the dose due to HTO exposures. Because few data on the characteristics of Japanese appliances as barriers to penetrating HTO had been available, HTO vapor permeabilities were measured for various plastic and rubber films of materials currently used in Japanese radiation protection appliances.

EXPERIMENTAL MATERIALS

Data were obtained with film specimens of polyethylene, polyvinyl chloride and polyvinyl acetate. They are plastics used as the materials of protective suits or wrappings. Also characterized were the specimens of urethane, chlorosulfonic polyethylene (hypalon), chloroprene (neoprene), butyl rubber and natural rubber. They are rubbers used as the materials of protective gloves. These specimens were all made by several Japanese manufacturers. They had the thickness of about 0.1 or 0.2 mm and the HTO permeating surface area of 54 cm².

EXPERIMENTAL METHODS

The permeability parameters measured were permeation coefficients, diffusion constants and solubilities. Based on the diffusion theory [1], these parameters were obtained by measuring the flux of HTO vapor permeating through specimen films as a function of time.

The permeation coefficient, P, is calculated by Equation (1) at the steady-state permeation:

$$P = F_s L / \Delta p \quad (1)$$

where F_s is the steady-state flux of HTO vapor permeating through the film, l is the film thickness and Δp is the partial pressure difference of water vapor between both sides of the film.

By plotting $t^{1/2}F$ versus $l^2/4t$ of Equation (2) on semi-logarithmic graph paper, the diffusion constant, D , is obtained from the slope of the plots:

$$\ln(t^{1/2}F) - \ln \{ 2 C_1 (D/\pi)^{1/2} \} = l^2/4t \quad (2)$$

where t is the time elapsed after the start of the exposure of the film to HTO vapor, F is the flux of the water vapor permeating through the film and C_1 is the concentration of water in the film on the surface exposed to the vapor.

Then the solubility, S , is calculated using Equation (3) with C_1 obtained from the intercept of the plots mentioned above:

$$S = C_1 / p_1 \quad (3)$$

where p_1 is the partial pressure of the water vapor at the surface of the film exposed to the vapor.

In order to measure the flux of water vapor, F , as a function of time, an experimental apparatus was made consulting D. H. Dougty's study of the Sandia National Laboratories [2]. The apparatus consists of the following parts: a generator of HTO vapor; a sample film holder; ethylene glycol bubblers where penetrating HTO is adsorbed; and two closed loops inside which HTO vapor circulates. All the parts is built in a constant temperature box.

With this apparatus, the time-dependent flux of HTO (then F and F_s in the Equations) was obtained by measuring the amount of tritium adsorbed in the bubblers-traps at certain intervals of time by liquid scintillation counting. The partial pressures p_1 and p_2 in the Equations were determined by monitoring the temperature and the relative humidity inside the closed loops of the apparatus.

RESULTS AND DISCUSSION

Permeation Characteristics of Protective Appliance Materials

Table 1 shows a summary of the permeability measurements for the specimens of various materials. As to the plastic polymers, the permeation coefficient of polyvinyl acetate was slightly larger than that of polyvinyl chloride, while the value of polyethylene was about 1/10 of those of the other two materials. The highest diffusion constant was found in polyvinyl acetate, while polyethylene had the lowest value. The difference in the values of diffusion constant among these plastics was not so large as that in the values of permeation coefficient. The solubilities increased in the order polyethylene < polyvinyl chloride < polyvinyl acetate. The value of polyethylene was about 10% of that of the others.

The data therefore prove that polyethylene is the best material among tested plastics from the viewpoint of HTO permeability.

As to the rubber materials, the highest permeation coefficient was observed in urethane. Natural rubber had the second highest value followed by neoprene and hypalon. The permeation coefficient of butyl rubber was the lowest among our results and was about 1/300 of that of urethane. The lowest values of diffusion constant and solubility were measured in butyl rubber. The data thus prove that butyl rubber excels as a material for HTO handling gloves with its low HTO permeability.

Effects of Desiccation Treatment on Permeation Behavior

The specimen films had been measured for their original values of the permeability parameters, then the films were desiccated and measured again for any changes of the parameter values. The desiccation treatment was carried out by exposing the surfaces of the wet films to dry circulating air. The HTO once adsorbed in the specimen films could be removed by the desiccation treatment.

The parameter values and the vapor flux curve measured after the desiccation well agreed with the original ones as in Table 1 and Figure 1, respectively. It can therefore be concluded that the desiccation treatment is effective for restoring the ability of the materials as a barrier against HTO vapor. As shown in Figure 1, desiccating glove materials can recover the smaller flux region at the initial stage of permeation, where the exposure to permeating HTO would be relatively small. If a worker would desiccate his gloves after each daily HTO handling operation and reuse the dried gloves within the smaller flux region in any operation, his exposure to penetrating HTO could be less significant than that in cases where he would use the wet gloves for several days without desiccation.

CONCLUSIONS

From the experimental data, the followings can be derived:

- (1) polyethylene and butyl rubber are materials suitable for HTO protective appliances with their low permeabilities;
- (2) when a protective appliance is repeatedly used, desiccating it before reuse may be effective for restoring its original resistance to penetrating HTO vapor and for reducing degree of HTO exposure.

REFERENCE

- [1] Crank, J.: Mathematics of Diffusion. 2nd Ed., Oxford Univ. Press, London, (1975)
- [2] Doughty, D.H.: The Measurement of Water Vapor Permeability of Glove Materials Using Dilute Tritiated Water. Journal of Nuclear Materials, 103 & 104, pp.1595-1600 (1981)

Table 1. Permeability Measurement (T=298K, Δp=2.7kPa)

Material	Thick. (mm)	Permeation coefficient ($\frac{\text{cm}^3 \text{ cm}}{\text{cm}^2 \text{ s Pa}$)	Diffusion constant ($\frac{\text{cm}^2}{\text{s}}$)	Solubility ($\frac{\text{cm}^3}{\text{cm}^3 \text{ Pa}}$)
polyethylene	0.09	3.6 E-12 * 3.6 E-12	6.7 E-09 * 6.2 E-09	4.5 E-04 * 4.7 E-04
polyvinyl chloride	0.09	4.4 E-11 * 4.1 E-11	7.8 E-09 * 7.4 E-09	4.4 E-03 * 5.0 E-03
polyvinyl acetate	0.10	5.7 E-11 * 6.1 E-11	8.9 E-09 * 9.5 E-09	5.2 E-03 * 5.1 E-03
urethane	0.21	1.3 E-09 * 1.8 E-09	1.2 E-08 * 1.9 E-08	7.2 E-02 * 6.1 E-02
hypalon	0.24	5.6 E-11 * 4.7 E-11	6.1 E-09 * 6.6 E-09	9.2 E-03 * 8.1 E-03
neoprene	0.20	5.3 E-11 * 6.2 E-11	6.5 E-09 * 6.9 E-09	7.4 E-03 * 7.5 E-03
butyl	0.21	4.3 E-12 * 3.5 E-12	2.0 E-09 * 1.9 E-09	1.5 E-03 * 1.4 E-03
natural rubber	0.24	1.8 E-10 * 1.7 E-10	1.8 E-08 * 1.8 E-08	7.7 E-03 * 7.3 E-03

* Data for the same specimen measured after the desiccation treatment

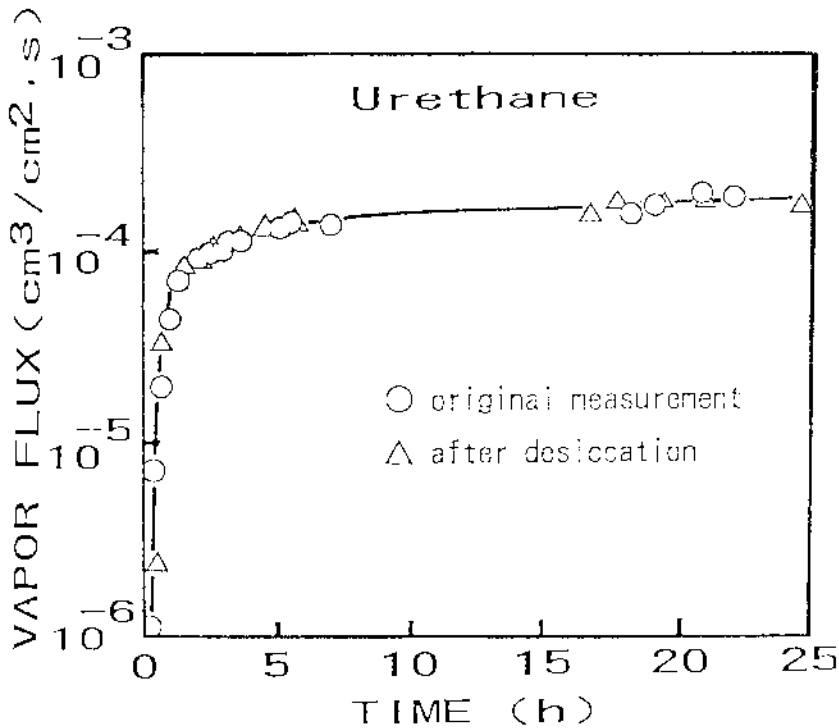

Figure 1. Plot of Vapor Flux vs. Time

APPORT DE L'INFORMATIQUE DANS LES CONTROLES EN CONTINU DE LA
RADIOACTIVITE DES INSTALLATIONS ET DE L'ENVIRONNEMENT DU
CENTRE D'ETUDES DE SACLAY

J. P. HULOT, J. CASTRI, G. ROBINET, R. TRAVAILLON

Commissariat à l'Energie Atomique
Département Sécurité Contrôle et Environnement
Centre d'Etudes de Saclay 91191 GIF/Yvette Cedex FRANCE

CONTRIBUTION OF COMPUTER SCIENCE IN CONTINUOUS RADIOACTIVITY
SURVEY IN PLANTS AND ENVIRONMENT OF CENTRE D'ETUDES DE SACLAY

Assignments of radiations survey board (local staff warning and overall follow up of plants) benefit by an important contribution of computer science in two fields :

- quality of measurements, principally measures of radioactive atmospheric aerosols pollution,
- increase of overall follow up by péripherals, especially by continuous recording measures.

The connection, by local network, of all survey boards can enable us further applications as decision making for incidental cases.

INTRODUCTION

Parmi les missions des unités de protection contre les rayonnements figure le contrôle permanent des:

- nuisances radioactives susceptibles de polluer l'environnement,
- risques radioactifs dans les installations.

Pour mener à bien ces missions elles disposent de systèmes de mesures en continu que sont:

- les Tableaux de Contrôle des Rayonnements (TCR) installés dans les installations (principalement les Installations Nucléaires de Base),
- le Tableau de Contrôle de l'Environnement (TCE) pour la surveillance de l'environnement du site.

Nous avons entrepris au centre de Saclay , depuis plus de 10 ans, un effort important de modernisation de ces tableaux de contrôle et à ce jour ce sont 10 "**systèmes informatisés de radioprotection**" qui fonctionnent en temps réel. Sur les 600 voies de radioprotection installées au centre d'études de Saclay, 530 sont traitées par un système informatisé.

En cas d'incident il est nécessaire de regrouper des informations provenant des différents systèmes de contrôle permanent (mesures dans l'installation en cause, mesures météorologiques, mesures dans l'environnement...). L'interconnexion des différents systèmes informatisés de contrôle de radioprotection en continu présente un intérêt majeur.

Tableaux de contrôle des rayonnements des installations

La mission d'un TCR d'installation est double :

- alerter localement les personnels du niveau de risque auquel ils sont soumis, cette mission est assurée par une signalisation, lumineuse et sonore, au poste de travail,
- permettre un suivi global de l'installation à partir du centralisateur en exploitant l'ensemble des mesures.

Les caractéristiques générales des TCR informatisés sont les suivantes :

Chaque voie de radioprotection est constituée :

- d'un capteur qui fournit un train d'impulsions de mesures et un état de fonctionnement,
- d'un coffret de signalisation qui reçoit une commande de signalisation et fournit un état de fonctionnement.

La gestion centralisée des mesures comprend :

- un synoptique d'alarmes,
- la visualisation permanente des états et des mesures,
- l'édition d'un journal de bord qui comporte : messages liés aux changements d'états et de plage et éditions cycliques de niveaux moyens et de cumuls,
- un traceur de courbes,
- un archivage des mesures sur plusieurs jours,
- un dialogue opérateur qui permet de modifier des paramètres de fonctionnement, d'éditer les mesures et cumuls et de tracer les courbes des mesures en temps réel ou en différé à partir de l'archivage.

Tableau de contrôle de l'environnement du centre de Saclay

Le TCE comprend des stations "environnement" (contrôle radiologique) réparties autour du site et une station météorologique située à l'intérieur du centre.

Chaque station comporte des capteurs appropriés et une unité de traitement, constituée autour d'un micro-processeur qui :

- assure l'acquisition des informations des capteurs,
- traite les informations capteurs pour élaborer une mesure exploitable,
- transmet au centralisateur les mesures et les états des capteurs.

Le rôle du centralisateur est de permettre un suivi aisé et permanent de l'ensemble des mesures des stations. Les mesures sont archivées et peuvent être facilement éditées sous forme de tableaux et de courbes.

La partie environnement utilise la balise à filtre séquentiel alpha et bêta composée de capteurs et d'une unité de traitement (BFSAB) développée spécialement à cet effet.

APPORT DE L'INFORMATIQUE SUR LA QUALITE DU TRAITEMENT DES MESURES

La mise au point d'algorithmes d'élaboration de mesures spécifiques à chaque type de capteurs [1] a permis d'obtenir une homogénéité des résultats de mesure. Toutes les mesures des TCR sont exprimées en LDO (Limite Dérivée Opérationnelle). Pour les mesures de contamination (aérosols et gaz) la LDO est égale à la limite dérivée de concentration dans l'air ($LDCA=LAI/2000h*1,2m^3h^{-1}$), elle dépend donc de la valeur d'un paramètre de radiotoxicité qui est introduit par les exploitants du TCR. Ce paramètre est choisi en faisant une hypothèse sur la contamination possible ; en général il est égal à la LAI la plus sévère probable pour le local surveillé. Dans le cas des mesures d'exposition externe la LDO est le débit de dose horaire moyen ($LAE/2000h$ soit $25 \mu Sv/h$).

L'intérêt de ces algorithmes se résume dans les quelques caractéristiques suivantes :

type de mesure (installation)	limite de détection	temps de réponse pour 1 LDO
Exposition externe	2.10^{-3} LDO	3 secondes
Gaz	0,2 LDO (C^{14})	3 minutes
Aérosols β	0,4 LDO ($Sr^{90}+Y^{90}$)	3 minutes
Aérosols α	0,5 LDO ($Pu^{238}+Pu^{239}$)	150 minutes

Dans le cas des mesures dans l'environnement où le bruit de fond, dû à la radioactivité naturelle, est variable et important par rapport à la sensibilité recherchée l'apport des traitements informatiques est fondamental, il peut se résumer dans le tableau ci-dessous :

type de mesure (environnement)	limite de détection	en présence d'un bruit de fond de
Exposit. externe	2 nGy/h	80 à 100 nGy/h
Gaz	50 mBq/m ³ (Kr^{85})	0,4 à 50 Bq/m ³ Rn^{222}
Aérosols β	0,2 mBq/m ³ ($Sr^{90}+Y^{90}$)	0,1 à 50 Bq/m ³ dér. Rn^{222}
Aérosols α	0,4 mBq/m ³ ($Pu^{238}+Pu^{239}$)	0,1 à 50 Bq/m ³ dér. Rn^{222}

Les principes généraux de tous les traitements ont été présentés au cours d'un séminaire AIEA [2].

APPORT DE L'INFORMATIQUE SUR L'EXPLOITATION DES MESURES

Sur ce plan l'apport de l'informatique se caractérise par:

- un suivi global de l'installation grandement amélioré grâce à la périphérie informatique et en particulier l'archivage des mesures qui permet à tout moment de ressortir les mesures des 10 à 20 derniers jours,
- un contrôle permanent du bon fonctionnement des différents composants du TCR : capteur, coffret de signalisation, unité de traitement et centralisateur,
- une très grande disponibilité des systèmes : à titre d'exemple 3 TCR organisés avec une architecture de traitement centralisé redondant ont accusé un taux d'indisponibilité de l'ordre de quelques 10^{-5} pour un temps de fonctionnement cumulé de plus de 200 000 heures.

Un autre aspect important est l'interconnexion des différents TCR et du TCE. Le RRRES (Réseau de Radioprotection et d'Environnement de Saclay) en place depuis plusieurs années permet de disposer en tout point de ce réseau des diverses mesures [3]. La connexion des TCR à ce réseau se poursuivra dans les années à venir.

CONCLUSION

L'obtention des mesures par des traitements élaborés améliore grandement la qualité de la radioprotection, nous continuons nos travaux dans ce domaine.

La fonction de centralisation bénéficie de tous les apports de l'informatique et son exploitation en est facilitée.

La réalisation d'un réseau constitue les bases qui permettront de réaliser, dans l'avenir, un système expert d'aide à la décision pour les situations accidentelles.

BIBLIOGRAPHIE

[1] J.CASTRI : Utilisation des traitements numériques pour le contrôle continu des rayonnements dans les installations nucléaires. Balises informatiques et algorithmes associés. Rapport CEA R-5081 (1981)

[2] J.CASTRI, B.GRIMONT, J.P.HULOT, R.PRIGENT : Techniques informatiques utilisées pour le contrôle continu des rayonnements dans les installations du Commissariat à l'Energie Atomique (traitements numériques de mesure : algorithmes, simulations, performances) AIEA Séminaire sur l'application des techniques informatiques à la radioprotection juin 1987.Bled (Yougoslavie).

[3] J.P.HULOT, J.ANDRE, D.BUSSON, C.VAN WAMBEKE : Réseau de radioprotection et d'environnement de Saclay (Interconnexion des TCR et du TCE). Communication aux journées PMDS 1989 Marseille (France).

FAST AND SENSITIVE DETERMINATION OF SR-90 AND SR-89 ACTIVITY IN MILK BY ION-CHROMATOGRAPHY AND LIQUID SCINTILLATION

V. Figueiredo and A. Herrmann
Food Control Laboratory, Basel, Switzerland

1. ABSTRACT

A method for fast and exact determination of both strontium isotopes in milk and other foodstuffs, combining high performance ion chromatographic separation with by liquid scintillation counting, which enables the desired results to be obtained with very satisfactory precision and reproducibility within 24 hours, has been developed. The lowest detectable activity lies by 3 Bq/liter for Sr-90 and 1 Bq/liter for Sr-89 which is satisfactory for assessing a situation in a time of crisis.

2. INTRODUCTION

After the accident in Chernobyl, the old problem of Sr-90 and Sr-89 activity measurements became topical once more. Again it was evident that the public as well as the authorities expected quick and reliable information after the event from the responsible laboratories. Due to the wide bands of energy emitted by the beta-radiation, a chemical separation of the nuclides to be measured is unavoidable. The methods used at the moment [1,2,3] involve tedious separations and reliable results require waits of several to 20 days. The method described here, a combination of high performance ion chromatography and liquid scintillation, enables us to obtain the necessary strontium preparation purity and to determine the activities of both Sr-90 and Sr-89 correctly and exactly within a working-day.

3. EXPERIMENTAL

After the removal of the milk protein with trichloroacetic acid, the alkaline earth metal ions are precipitated as oxalates, converted to carbonates by ashing and the strontium as well as the barium ions precipitated as nitrate salts. An aliquot of the nitrate salt is put through a chromatographic system, the strontium peak-volume collected and the activity of both strontium isotopes measured by low-level liquid scintillation. The chemical manipulations require approximately 7 hours and the counting 3 hours.

3.1. ISOLATION OF STRONTIUM FROM MILK

The isolation of strontium is performed according to [4], using 1 liter of milk and adding 40 mg each of strontium and barium carrier. The procedure is interrupted at the level of the nitrate precipitation. The precipitate dissolved in 5 ml water (sample solution) is then used for the ion chromatography.

3.2. FINE CLEANUP OF STRONTIUM BY ION-CHROMATOGRAPHY

250 μ l of the sample solution are injected into the chromatographic system described below. After the detection by conductivity the strontium peak-volume is collected in a counting vial, mixed with PICO-AQUA cocktail and counted as soon as possible.

Column : DIONEX HPIC-CS3 and HPIC-CG3
Eluent : HCl 48 mM, diaminopropionic acid hydrochloride 16 mM
Flow-rate : 1 ml/min
Detection : Suppressed Conductivity

3.3. CHEMICAL YIELD

The chemical yield of the precipitation is also determined by ion chromatography after adequate dilution of the sample solution. The concentration of the sample solution and thereby the chemical yield are determined using an external standard.

3.4. MEASUREMENT OF SR-90/SR-89 ACTIVITIES BY LIQUID SCINTILLATION

The scintillation spectra are measured on a TRICARB 2250CA low level liquid scintillation analyzer from PACKARD. The activities of Sr-90 and Sr-89 of the collected fraction are determined by dual label DPM analysis with AEC (Automatic Efficiency Control) in the following optimized energy windows: 5-200 keV for Sr-90 and 200-1200 keV for Sr-89.

Preparation of the Quench Curves:

As commercially obtained Sr-90 is in equilibrium with its daughter Y-90, it is necessary to purify the Sr-90 standard solution by chemical separation [2] before preparing the quench sets.

Sample measurement:

The sample activity must be measured directly after the eluate is collected, but after a few minutes equilibration in the cooled sample collector. The samples are counted over a period of 180 minutes.

4. RESULTS AND DISCUSSION

At the present time adequate preparative columns are not available: the DIONEX HPIC-CS3 is an analytical column. However the quantities and volumes given here result in a good recovery rate of added strontium. Starting with one liter of milk, with the stated amounts of strontium and barium added, a chemical yield of $68 \% \pm 2 \%$ ($n = 10$) was obtained.

Under the given conditions of the ion-chromatographical purification the alkaline earth metal ions are separated, while the alkaline metal ions are eluted with the water peak. Trivalent ions such as lanthanides, yttrium and the transitional metals are held back by the column. If in the case of milk, the calcium is not removed with nitric acid separation,

a large excess of calcium will be present which prohibits a separation of the peaks. One single nitric acid separation completely eliminates any alkali ions that may possibly be present and reduces the calcium concentration by a factor of 1000.

Although the analytical chromatography column is clearly overloaded, the strontium-peak is well resolved from the barium-peak. The addition of barium carrier solution permits a well timed interruption of the collection of the strontium fraction.

With the possibility of dual label DPM counting, spectral separations of both radiations (max. energies: 0,546 keV for Sr-90, 1,492 keV for Sr-89), activity ratios of Sr-90/Sr-89 from 1:50 to 50:1 can be measured well. The two established quench curves in the chosen energy windows for Sr-90 and Sr-89 give a constant spill-up and spill-down. The efficiencies for both isotopes lie by 70 % for Sr-90 and 67 % for Sr-89.

Due to the ingrowth of Y-90, after a counting time of 180 minutes only an Y-90 activity of approximately 3 % of the Sr-89 activity will be present. The Beta-radiation from Y-90 appears mainly in the Sr-89 window and so can simulate Sr-89 activity.

5. QUALITY CONTROL OF THE METHOD

At the end of 1990 we received several food samples from Chernobyl, whose activity had been determined with gamma-spectrometry. In 5 samples, the Sr-90 activity was determined with the up to then applied method [2], which is based on the measurement of the chemically separated Y-90 using a gas-proportional counter. The direct determination of the Sr-90 activity of these samples was likewise carried out using the method described above, also only 250 ml of milk and 500 ml of water could be used (Table 1).

Table 1: comparison of the methods: Sr-90 in milk and water samples from Chernobyl (Bq/liter)

sample	method [2]	this method	difference
milk 1	5,6 ± 0,1	5,7 ± 0,6	+ 1,8 %
milk 2	8,4 ± 0,1	7,6 ± 0,8	- 9,5 %
milk 3	10,9 ± 0,2	13,8 ± 1,4	+26,6 %
milk 4	9,9 ± 0,2	10,0 ± 1,0	+ 1,0 %
pond water	46,9 ± 4,5	52,0 ± 2,6	+10,9 %

The difference in the results varies between 1 and 27 %, with a mean value around 10 %. In view of the given degree of pure statistical error (1 sigma), the differences are not significant except in milk sample 3. With the limited volume available, the results are very satisfactory.

A further comparison, on the basis of an interlaboratory test organized by the Berlin Ministry of Health (BGA) is shown in table 2.

Table 2: Interlaboratory test, BGA Berlin 1990 (Bq/liter)

nuclide	method [2]	this method	nomial value
Sr-90	4,3 ± 0,2	4,4 ± 0,4	4,2
Sr-89	-	7,0 ± 0,7	5,3

The sample (water) contained, apart from the two Sr-isotopes, also H-3, Co-60, Zn-65, Cs-134, Cs-137 and Ce-141. The strontium activities measured with both the tested methods agree very well with the expected value. The Sr-89 activity found by the method described here actually deviates by 30 % from the value given by the BGA, but with an activity of only 2,7 Bq/liter at the time of measurement (70 days after the reference date) it is not surprising.

6. CONCLUSIONS

The method described here has shown to be very reliable: the ion chromatography allows a maximum purity of the strontium fraction to be obtained, and the liquid scintillation permits a simultaneous determination of both strontium isotopes. The detection limit lies by 3 Bq/liter for Sr-90 and 1 Bq/liter for Sr-89. Even when this method, at the moment has only been tested by means of some samples from Chernobyl and spiked samples, it can be used for other foodstuffs with the appropriate preparation, without further ado, or in nuclear plant laboratories for their own control of waste water.

Thus it is possible to perform quick and reliable strontium analyses after an event and take the necessary precautionary measures or issue recommendations promptly.

7. REFERENCES

- [1] Wilken, R.D. and Diehl, R., 1989, Überwachung der Sr-89/Sr-90-Aktivität von Kuhmilch, Empfehlungen zur Ueberwachung der Umweltradioaktivität, Fachverband für Stahlschutz e.V., Loseblattsammlung FS-78-15-AKU
- [2] Erard, M. and Zimmerli, B., 1988, Bestimmung von Strontium-90 in Milch, Mitt. Gebiete Lebensm. Hyg., 79, pp. 48-56.
- [3] Baratta, E.J. and Knowles, F.E., 1973, Ion Exchange Determination of Strontium-89 and Strontium-90 in Milk, Journal of the AOAC, 56, 1, pp. 213-218
- [4] Morre, J., Janin-Caufment, F. and Mazer, J.P., 1971, Analyse radiobiologique rapide et complete d'un lait, Rapid Methods for Measuring Radioactivity in the Environment, Proceedings of an International Symposium held in Neuherberg, 5-9 July 1971, International Atomic Energy Agency, Vienna, pp. 233-239 (IAEA-SM-148/46)

ETUDE DE COMPTEURS MINIATURES POUR LA DOSIMETRIE
INDIVIDUELLE DES NEUTRONS

J. BARTHE, M. MOURGUES, J.M. BORDY, B. BOUTRUCHE,
T. LAHAYE et G. PORTAL.
CEA/Institut de Protection et de Sureté Nucléaire
Département de Protection de l'homme et Dosimétrie
P. SEGUR
CPAT, ERA277, Université P. Sabatier, TOULOUSE

STUDY OF MINI-COUNTERS FOR PERSONAL NEUTRON DOSIMETRY

The characteristics of three electronic detectors designed for personal neutron dosimetry are compared: a multicellular tissue equivalent proportionnel counter, a differential diode detector and a detector operating in a partial G.M. regime. The two detectors employed the same thin film of Boron-10 doped polyethylene as a neutron to proton converter.

INTRODUCTION

Il n'existe pas, à l'heure actuelle, de dosimètre électronique individuel commercialisé permettant d'évaluer, en temps réel, la dose due aux neutrons dans les champs mixtes. Les recherches entreprises dans le service sur ces capteurs dosimétriques concernent la conception et l'étude d'un détecteur électronique miniature susceptible d'équiper les futurs dosimètres individuels. Parmi les difficultés qui se présentent, les deux plus importantes sont l'obtention d'une sensibilité aux neutrons et d'une discrimination neutron/gamma suffisantes.

COMPTEUR PROPORTIONNEL

Le principal défaut des compteurs proportionnels, utilisés en microdosimétrie, est leur manque de sensibilité, consécutive à

la faible section efficace de collision élastique microscopique des neutrons avec les atomes d'hydrogènes constituant le matériau équivalent tissu. Pour compenser cet effet, il faut accroître la surface d'échange entre la cathode et le gaz détectant les particules secondaires chargées (1).

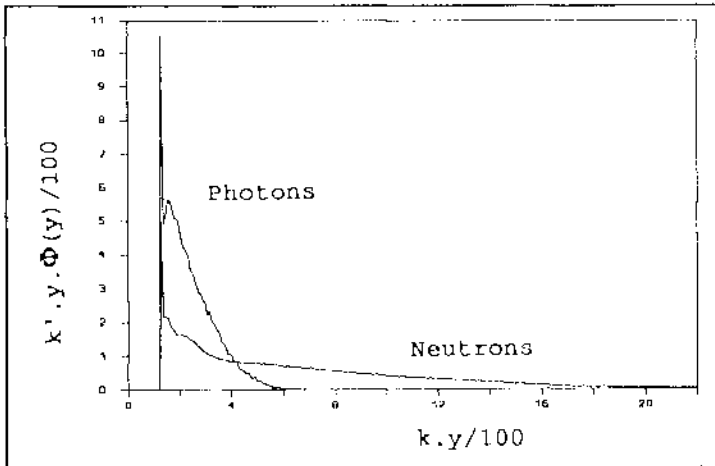

Figure 1: Distribution de la dose en fonction de l'énergie linéique.

Les comp-teurs proportionnels auront en général des dimensions importantes, diamètre supérieur à 5 cm (2), rendant ainsi impropre leur utilisation comme capteur dans un dosimètre individuel.

La surface d'échange, entre la paroi et le gaz du compteur développé dans le service, est accrue par le forage d'un ensemble de canaux borgnes orthogonaux à la surface interne (3). Selon le diamètre des canaux et l'épaisseur de la paroi, l'accroissement de surface peut atteindre un facteur 10 par rapport au compteur orthocylindrique de même volume (4). Le volume de détection n'est plus convexe et la simulation d'un site microscopique imparfaite. Ceci n'est pas rédhibitoire dans la mesure où une deuxième interaction du même neutron incident avec une nouvelle zone de la cathode est improbable. L'épaisseur entre les canaux est suffisante pour arrêter toutes les particules secondaires chargées à l'exception toutefois des électrons d'énergie supérieure au MeV.

Dans le cas du compteur multicellulaire (4), le calcul de la distribution de la longueur des cordes donne une distribution de Dirac dont la valeur la plus probable correspond sensiblement à la valeur moyenne. La figure 1 donne la réponse du compteur monocanal, normalisée à la même charge collectée pour les photons du cobalt-60 et les neutrons d'une source d'Am-Be. Ces spectres sont déformés par la présence de l'encainte métallique qui entoure, pour le moment, la maquette du compteur.

DOUBLE DIODES

De nombreux auteurs ont étudié la réponse aux neutrons des détecteurs solides de traces (DST) avec et sans convertisseur hydrogéné.

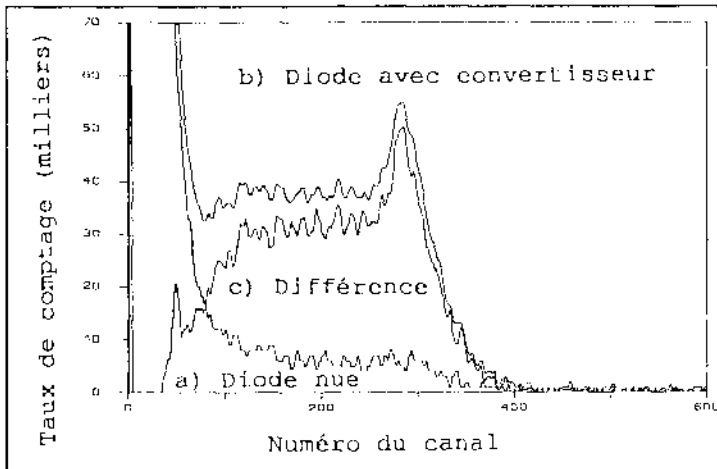

Figure 2: Réponse différentielle du système de détection, source Am-Be.

Barélaud et coll. (5) ont remplacé le DST par une diode. Celle-ci détecte les particules secondaires chargées créées dans le convertisseur, principalement les protons dus à la diffusion élastique des neutrons et les particules alpha dues à la réaction des neutrons de faible énergie avec le bore-10. Afin de séparer au mieux la réponse des photons de celle des neutrons, une deuxième diode, de caractéristique équivalente, mesure la composante photonique

ainsi que les interactions directes avec les neutrons. La différence de réponse des deux diodes est exclusivement liée à la réponse du convertisseur aux neutrons.

Le principal avantage de ce système est lié à la réponse du convertisseur; en effet Makovicka (6) a montré que, pour une épaisseur de polyéthylène d'environ 30 μm , le débit de fluence des protons émergeant du radiateur est sensiblement proportionnel (à $\pm 30\%$) au débit d'équivalent de dose neutronique entre 100 keV et 5 MeV. Une implantation adéquate en bore-10 permet d'étendre la gamme de mesure jusqu'à l'énergie des neutrons thermiques. Un second avantage est lié à la faible tension de polarisation des diodes particulièrement bien adaptée au détecteur individuel. Plusieurs inconvénients existent: le bruit de fond propre des diodes qui limite le seuil de détection à quelques dizaines de keV, l'épaisseur de la zone morte qui arrête les particules chargées de faible énergie ou très ionisantes, la forte sensibilité aux photons.

La figure 2 donne la réponse, pour les neutrons d'une source d'Américium-Beryllium, de la diode nue (a), de la diode sous convertisseur (b) ainsi que la réponse différentielle du système de détection.

COMPTEUR A REGIME GM PARTIEL

La sensibilité du système de détection est directement liée à la surface du détecteur, soit 1,5 cm^2 dans le cas des diodes. Afin d'accroître, sans coût excessif, la sensibilité du capteur, la diode est remplacée par un compteur fonctionnant en régime GM partiel dont la surface sensible peut atteindre plusieurs

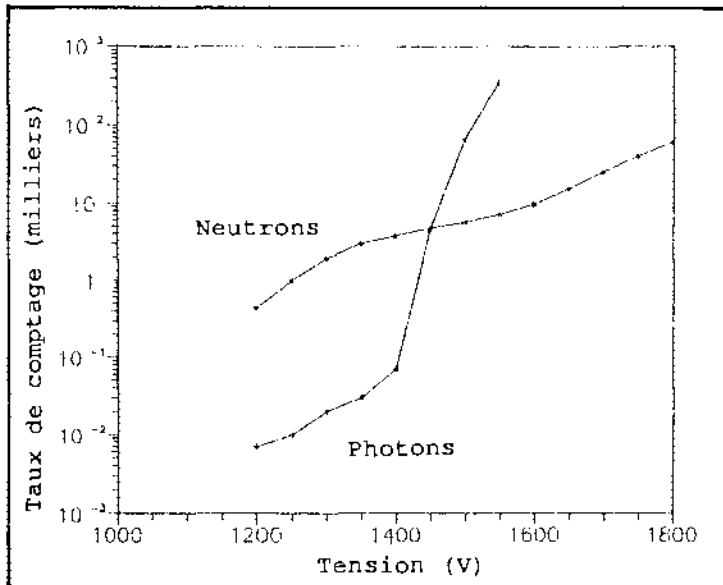

Figure 3: Taux de comptage en fonction de la tension appliquée.

dizaines de centimètres carrés. Dans la maquette étudiée, la cathode est constituée d'une feuille métallique dont la surface intérieure est recouverte d'une fine couche de polyéthylène, ce dernier étant rendu macroscopiquement conducteur électrique. La cathode est constituée soit par un parallélogramme ou soit par un ensemble de tubes cylindriques.

celle du DINEUTRON pour un poids et un encombrement du détecteur plus faibles.

Les matériaux constituant la cathode et sa structure de maintien sont choisis de telle sorte que l'interaction avec les photons soit minimale; ceci permet de s'affranchir de l'utilisation d'un deuxième détecteur de compensation. Comme pour la diode, une implantation de la cathode en bore-10 permet de détecter les neutrons thermiques et épithermiques. La figure 3 donne, pour un même débit de dose, les réponses respectives du détecteur aux neutrons d'une source de californium et aux photons du cobalt-60 en fonction de la tension appliquée.

CONCLUSION

Si l'obtention d'un capteur dosimétrique individuel, à partir d'un compteur proportionnel pose encore de nombreux problèmes technologiques (gain gazeux, stabilité à long terme, etc.), il est par contre certain que la réalisation d'un compteur à régime GM partiel ou, plus encore, d'un ensemble différentiel à diodes ne pose aucun problème majeur. Il faut toutefois noter que le compteur proportionnel donne une information dosimétrique complète: dose, équivalent de dose et facteur de qualité moyen, alors que les détecteurs à convertisseur hydrogéné ne fournissent a priori que l'équivalent de dose.

BIBLIOGRAPHIE

(1) P. KLIAUGA, H. H. ROSSI and G. JOHNSON: A multi-element proportional counter for radiation protection measurements, Health Physics, 57, N°4, (1989) pp. 631-636.

(2) EURADOS INTERCOMPARISONS: Investigation of radiation protection instruments based on tissue-equivalent proportional counters, Kernforschungsanlage, Jülich (1988).

(3) D. BLANC, P. SEGUR, J. BARTHE et J.M. BORDY: Utilisation des compteurs proportionnels à milieu équivalent au tissu biologique, 8ième Congrès IRPA, Montréal 17-22 Mai (1992), Québec, Canada.

(4) J.M. BORDY: Caractérisation d'un compteur proportionnel équivalent tissu à dérive, Mémoire CNAM (PARIS) à paraître.

(5) B. BARELAUD: Conception et réalisation d'un capteur pour les neutrons thermiques et rapides, Thèse d'université, Limoges France, n°7-89, Avril (1989).

(6) L. MAKOVICKA: Contribution à la dosimétrie neutron-gamma: Etude d'un ensemble radiateur-détecteur type CR39, Thèse d'état, Université de Limoges France, n°.17-87, Mai (1987).

DEVELOPPEMENTS D'UNE ANALYSE AUTOMATIQUE D'IMAGE
POUR LE COMPTAGE DE FILMS DOSIMETRIQUES

F. BERGER ¹, D. KLEIN ², R. BARILLON ¹ et A. CHAMBAUDET ¹

1 - Laboratoire de Microanalyses Nucléaires, U.F.R. des Sciences
et de Techniques, Université de Franche Comté,
25030 Besançon, France

2 - Laboratoire de Metrologie des Interfaces Techniques, IUT
Belfort-Montbéliard, Rue Engel-Gros, BP 527,
90016 Belfort Cedex, France

DEVELOPEMENT OF AN AUTOMATIC IMAGE SCANNER FOR DOSIMETRY
ANALYSIS

Solid Nuclear track detector in dosimetry are necessary for numerous uses. We have developed image analysis for scanning and measuring nuclear tracks (alpha, proton and fission fragment) in various detectors. The track density makes it possible to calculate the activity concentration to which the detector has been exposed. Special computer programs enable us to count both low and high densities.

INTRODUCTION

L'analyse d'image a pour but d'extraire d'une image brute des informations concernant des structures particulières appelées "objet". Dans le cas du comptage de films dosimétriques, l'analyse automatique des traces nucléaires doit permettre d'accéder dans les meilleures conditions de temps et d'efficacité à la densité de trace et donc à l'exposition auxquelles ont été soumis les films.

LE SYSTEME D'ANALYSE D'IMAGE

Le système de base utilisé est commercialisé par la Société OLYMPUS sous le nom de CUE-2. Il comporte les éléments présentés sur la figure 1.

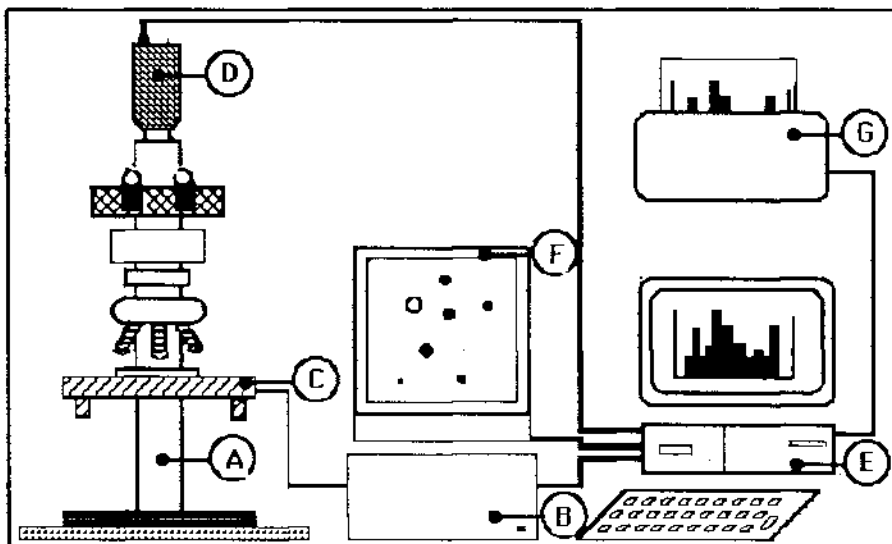

FIG 1: Le système d'analyse d'images

microscope optique (A), contrôleur de déplacement x, y et z (B), platine motorisée (C), caméra video CCD (D), micro-ordinateur (E), moniteur image(F) et imprimante laser (G)

DEROULEMENT D'UNE ANALYSE D'IMAGE

Le programme informatique réalise l'analyse d'image en quatre phases essentielles précisées dans le schéma suivant :

- acquisition de l'image : pour réaliser de telles observations, le traitement d'image est connecté a un microscope optique (BH2), pouvant travailler à la fois en lumière transmise ou en lumière réfléchie. Dans le but d'accroître son efficacité, le système est de plus équipé d'une platine microscope motorisée. Cette platine motorisée permet un déplacement suivant les trois axes x, y, z. Le déplacement suivant l'axe z permet le réglage de la netteté de l'image au moyen d'un système autofocus.

- mise en valeur et prétraitement : l'opérateur fixe un intervalle de niveaux de gris englobant au mieux les niveaux de gris des pixels constituant les objets. L'image est ensuite binarisée suivant les valeurs de niveaux de gris seuils imposés.

- analyse des objets de l'images : dans sa configuration de départ, le logiciel est capable de caractériser chaque objet analysé avec plus de trente paramètres géométriques (surface, périmètre, diamètre de férêt,...). dans le cadre des améliorations que nous avons développées l'ensemble des paramètres est fixable.

- sortie des résultats de l'analyse sous la forme d'histogrammes ou de courbes caractéristiques de chaque champ analysé ou de l'ensemble de la surface.

APPLICATIONS DU SYSTEME POUR LE COMPTAGE DE FILMS DOSIMETRIQUES

Ce type de détecteurs polymériques permet la caractérisation des interactions des rayonnements nucléaires suivant : alpha, neutron, proton et produits de fission.

Le but du développement d'une analyse de ces détecteurs par traitement d'image est principalement destiné à la détermination de densité des traces, c'est à dire à la mesure des événements nucléaires subits en surface. Dans certains cas, il est également nécessaire d'accéder à tous les paramètres de forme et à la cartographie des traces sur l'ensemble de la surface.

Pour ce faire, le système a été adapté à l'analyse automatique de détecteurs solides de traces nucléaires, deux catégories d'analyses ont requis une adaptation particulière :

- les films à faible densité de traces car ils nécessitent la prise en compte d'une surface importante du détecteur pour obtenir un résultat fiable.

Pour ce faire un programme informatique spécifique est utilisé pour piloter le déplacement de la platine en x et y afin de compter toute la surface de plus il y a également un contrôle des fluctuations de focalité avec correction en jouant sur l'axe z

- les films à forte densité de traces, car dans ce cas certaines traces se chevauchent, ce qui nécessite un traitement spécial pour les séparer.

L'étude de ce type de films à forte densité est réalisée en utilisant également un programme spécialement développé qui d'une part peut comparer les objets observés par rapport à une bibliothèque de traces se recouvrant ou peut retrouver par traitement mathématique la forme des traces initiales dans un recouvrement.

Les résultats obtenus par analyse d'image et leur comparaison avec ceux réalisés au moyen d'un comptage semi-automatique par un opérateur sont tout à fait adaptés à l'analyse de détecteurs à faible et à forte densité.

CONCLUSION

Les différents développements de l'analyse d'image présentés dans le cadre de ce travail montrent l'intérêt de cette technique pour l'analyse des traces nucléaires.

Les différents programmes informatiques nous permettent à la fois de qualifier et d'extraire des formes caractéristiques de traces d'une surface et de quantifier leurs répartitions sur le matériau.

Le temps d'analyse est très court, par exemple le traitement d'un détecteur de traces nucléaires qui demande une heure par cette technique en demande cinq fois plus en comptage optique par un opérateur.

De plus, l'automatisation de ce traitement permet de réaliser un nombre important d'analyses pour vérifier les résultats, ce qui par analyse optique directe n'est pas envisageable.

Après avoir développé des méthodes d'études efficaces, par observation microscopique, il s'avère que de nombreuses applications de ce traitement sont encore à venir.

BIBLIOGRAPHIE

1. Rebetez M., B. Zoppis, A. Rebrab, P. Grillon, E. Gentilla et A. Chambaudet ,
"Atom: a semiautomatic measuring system for the analysis of fission track characteristics in anisotropic minerals",
Nucl. Tracks Radiat. Meas., in press
2. Barillon R., D. Klein , A. Chambaudet, F Membrey et M. Fromm, "Additional uses of polymeric nuclear track detectors (CR39 and LR115) for measuring radon emanation",
Nucl. Tracks Radiat. Meas., in press
3. Chambaudet A. , D. Fellmann, M. Fromm and D. Klein,
"Counting in plastic track detector during routine work,
Nucl. Tracks Radiat. Meas. Vol. 15, Nos 1-4, pp 287-290,
(1988).
4. Chambaudet A. , F. Berger, D. Klein, D. Fellmann et R. Barillon, "Development of an automatic image scanner for nuclear track analysis", *Nucl. Tracks Radiat. Meas.*, in press
5. Berger F., "Etude de surfaces par analyses d'images", DEA de Chimie-Physique, Besançon, 24 pages, (1990)

BACKGROUND TRACKS IN CR-39 SSNTD SHEETS: THEIR CONTROL AND PREDICTION THROUGH AN INTERPLAY OF ETCHING PARAMETERS

A.M. Bhagwat, G.R. Naik, S.Thampan, K. Rudran,
V.B. Joshi and M.R. Iyer

Radiation Safety Systems Division
Bhabha Atomic Research Centre
Bombay - 400 085, INDIA

ABSTRACT

High sensitivity of CR-39 film in turn leads to higher and variable background track-densities. A two-step etching process, each consisting of CE and ECE, is therefore suggested which permits not only partial freezing of the background but also allows to know its level. The procedure identifies bad pieces with scratches and determines the minimum detection limit (MDL) of each film individually. Activities as low as 0.2 mBq ($\approx 5 \times 10^{-15}$ curies) can thus be measured with low background films for exposure periods of 7-10 days (exposure is carried out after first processing).

INTRODUCTION

The discovery of low detection threshold CR-39 track detector by Cartwright et al in 1978 and subsequent appearance of its improved version, SR-86 (Fujii & Yokota, 1988) has tremendously extended the areas of application of technique of Solid State Nuclear Track Detection (SSNTD). One of the noteworthy areas of its applications is "measurement of low levels of activity in a variety of matrices. Our interest in this area has been constantly growing over the years. (Bhagwat et al, 1988). During the followup studies it became evident that the background in CR-39 pieces is largely variable. Further, though it should be preferably low, there should be a way of knowing it in advance. The possibility of controlling the background should also exist. This paper suggests a new approach to the problem highlighted above.

APPROACH TO THE PROBLEM

A two-step processing of CR-39 was visualised for the purpose. The first step was intended to i) reveal the background in the film ii) show the surface quality, i.e. with or without scratches and iii) select pieces for a particular measurement based on acceptable level of background. It was also realised that background tracks will increase further in number during second step of processing. It is the background appearing in the second step which will interfere with experimental measurement. If possible therefore, it should be quantified to enable assessment of contribution from the experimental exposure. The details of this investigation are explained in the following sections.

EXPERIMENTAL

Since the whole exercise is oriented towards measurement of low track densities, it was decided to incorporate both chemical etching (CE) and Electrochemical etching (ECE) in each step of processing so that large/entire area of film could be easily counted. The optimum etching times were selected as follows.

The conditions of processing during second step were those adopted for revelation of alpha tracks in CR-39, i.e. CE of 6h in 6N KOH at 60°C and ECE at room temperature (22° - 24°C) for 15h employing 6N KOH and applying an AC field of 6 Vp/μm of film thickness (= 500 μm) at 500 Hz.

The ECE conditions for the first processing were maintained the same as those in the second processing. The time of CE was however, varied to study its influence on revealed number of tracks. This data is shown by the lower curve in fig. 1. The time of CE was varied from zero hour to 18 h in steps of 2 h. The initial part of this curve is shown by dashed line. This was because a smooth curve was difficult to draw in this region due to large scatter in experimental points. The latter part of the curve, however, shows a smooth variation and is depicted by a continuous curve. This part of the curve also reveals that observed number of background tracks is low for chemical etching times corresponding to 12 to 14 h. The time of CE in the first processing was therefore fixed at 12 h for all subsequent measurements.

The upper curve in fig. 1 shows the effect of second processing (where CE and ECE conditions are already fixed) on the data revealed by the lower curve. It is seen that in the region of continuous curve, the final number of tracks continues to be low for the same region where the first curve has its minimum. This further substantiates the selection of 12 h of CE in the first processing.

RESULTS AND DISCUSSION

In order to study the relationship between number of tracks revealed in the first and second processing steps, a large number of films were subjected to two processing steps without any exposure in between. Fig. 2 shows this data. A quantitative relationship is found to exist between two sets of data, i.e. it is possible to predict the background generated during the second processing from the number of ECE spots observed after the first processing. The figure also shows 95% confidence level (CL) lines (= 1.96 σ), i.e. the standard deviation of the second step background is automatically known for any level of background.

Before obtaining the line of best fit, Dixon Criterion (Dixon, 1973) at 90% C.L. was applied to search for possible outliers. Two points (out of 39) were rejected on this basis. The line of best fit was then obtained by the method of weighted least squares. The equation for this line is

$$Y = 0.845 X \text{ -----} \quad (1)$$

The upper and lower bound lines at 95% C.L. are

$$Y = 1.514 X \text{ -----} \quad (2) \quad \& \quad Y = 0.176 X \text{ -----} \quad (3)$$

The coefficient of correlation (r) for the data was found to be 0.465. Student's t -distribution test was also applied ($t=3.512$) to the data [$t(0.99)_{37}=2.447$ from the tables] which proved that a significant relationship exists ($3.512 > 2.447$).

A salient point about the above study is that it permits i) rejection of pieces with scratches and ii) calculation of MDL separately for each film based on its background observed after the first processing. The MDLs corresponding to 2σ and 3σ limit as a function of ECE spots observed after the first processing are shown in fig. 3. Thus for 30 (or less) ECE spots after first processing, one can measure activities as low as 0.2 mBq (≈ 5 femtocuries) for exposure period of one week (see the 30 line).

APPLICATION OF THE TECHNIQUE

The above technique was used to evaluate the strength of standard alpha sources of low activity, prepared by evaporating a few lambda of standard stock solution on teflon planchets. Source area was 10 mm in diameter. The teflon planchets were thoroughly cleaned previously by employing standard chemical procedures and their background was measured by SSNTD technique only.

CR-39 films (after their first processing) were exposed to two such sources twice for 12 days each. The measured average source strength was (0.018 ± 0.0018) dpm ($= 0.3$ mBq) which is in reasonably good agreement with the quoted value of (0.024 ± 0.006) dpm ($= 0.4$ mBq).

CONCLUSION

The above results confirm the utility of the technique at the level mentioned. Further improvements in M.D.L. are possible by increasing the time of exposure. However, more significant contribution to M.D.L. may come from future improvements in the quality of CR-39 leading to lower backgrounds and reduced uncertainties.

REFERENCES

- Bhagwat, A.M., Parmeshwaran, M., Panday, V.K., Dang, H.S., Sunta, C.M. and Soman, S.D., (1988), 7th IRPA Congress Proceedings, pp 1134-1137.
- Cartwright, B.G., Shirk, E.K. and Price, P.B. (1978), Nucl. Instrum. & Meth, 153, 457-460.
- Dixon, W.J., (1973), Biometrics, 9, 74.
- Fujii, M. and Yokota, R., (1988), Nucl. Tracks Radiat. Meas., 15, 107-110.

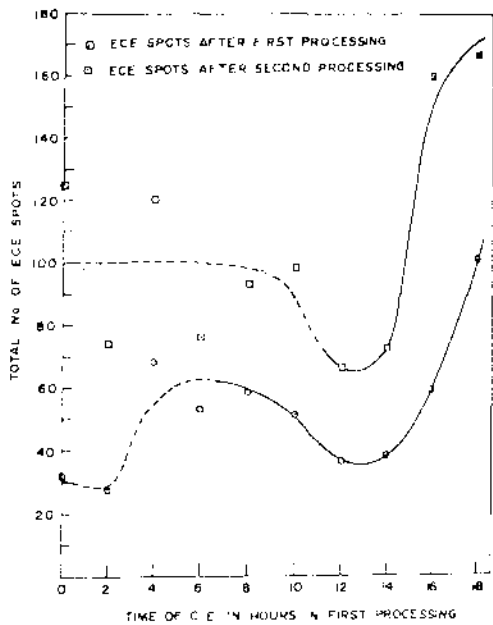

FIG 1 VARIATION OF ECE SPOTS AS A FUNCTION OF TIME OF CE IN THE FIRST PROCESSING (AREA SCANNED = 78 cm².)

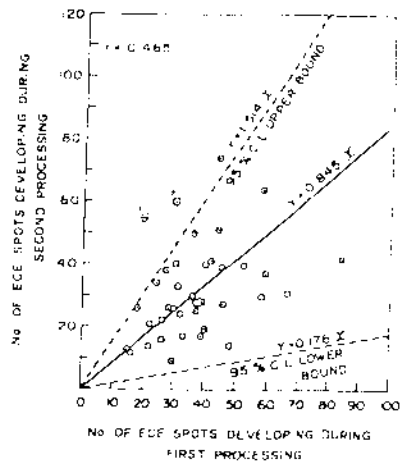

FIG 2 RELATIONSHIP BETWEEN ECE SPOTS DEVELOPING DURING FIRST AND SECOND PROCESSING

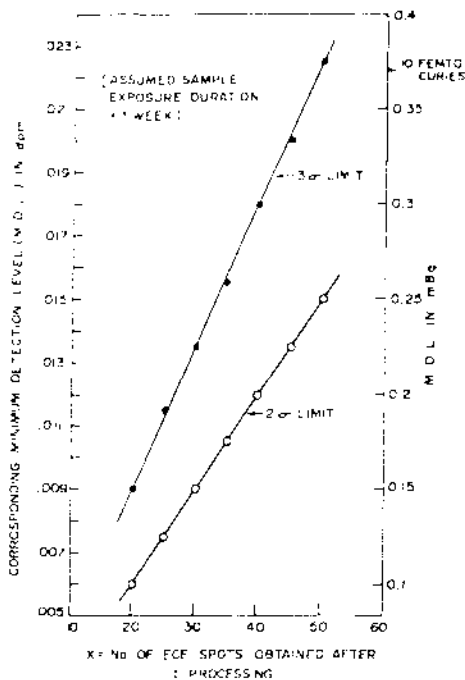

Fig 3 Variation of M.D.L. as a function of ECE spots obtained in the first processing (AREA SCANNED = 78 cm²)

A Compact System for Neutron Spectrometry*

J.-F. Vailey¹, A. Aroua¹, M. Grecescu¹, P. Lerch¹ and S. Prêtre²

1 Institute for Applied Radiophysics, CH-1015 Lausanne

2 Swiss Nuclear Safety Inspectorate, CH-5303 Würenlingen

* This work has been financially supported by the Swiss Nuclear Safety Inspectorate

Abstract

A neutron spectrometer based on Bonner spheres has been calibrated in monoenergetic neutron beams. The response matrix has been interpolated using a one dimensional transport calculation. The unfolding code SAND has been implemented on a personal computer leading to a compact measuring system. The validation of the response matrix and of the unfolding procedure was performed using measurements of known spectra. The system has been applied satisfactorily as a reference instrument in nuclear power plants and near medical accelerators.

1. Introduction

Dosimetric quantities related to neutron irradiation are strongly dependent on the energy spectrum of the radiation. Two common methods are used in order to obtain relevant dosimetric information. In the first one the neutron energy fluence is measured using a set of moderating polyethylene spheres (Bonner spheres); the dosimetric quantities (absorbed dose, dose equivalent, quality factor and radiation weighting factors) are obtained by convoluting the energy spectrum with conversion factors derived from Monte Carlo calculations. The second method is based on microdosimetric measurements using a tissue equivalent proportional counter (TEPC); in this case the LET spectrum allows the calculation of the dosimetric quantities.

The first approach was chosen because it provides through the fluence energy spectrum a better insight into the radiation protection conditions. A particular effort has been devoted to the determination of the characteristics and the performances of the system and to its integration in a compact measuring system.

2. Description

The spectrometric system used [1] comprises 11 moderating spheres made of polyethylene with diameters of : 2, 2.5, 3, 4.2, 5, 6, 8, 9, 10, 12 and 15 inches (") (from 5.08 to 38.1 cm). Spheres with diameters smaller than 6" can be covered by a cylindrical cadmium box, in order to absorb the thermal component of the incident neutron spectrum. The thermal neutron detector used is a miniaturized proportional counter filled with

helium-3. The preamplifier located close to the counter is linked through 20 m long cables to a standard spectroscopy instrumentation. An optimal discrimination level which insures a good rejection of noise and γ rays without affecting the neutron sensitivity too much, has been chosen.

The dead time of the electronics is 6 μ s and the gamma sensitivity of the ^3He counter is very low (0.01 imp. / μ Sv for the cobalt-60 γ field). The nominal value of the counter's sensitivity to thermal neutrons is 6.10^4 imp./ μ Sv which leads to a relative sensitivity (n/γ) of 6.10^6 . Even in the worst case where the bare counter is placed in a hard spectrum such as that of americium-berillium and where the sensitivity to neutrons is 1 imp./ μ Sv only, the relative sensitivity (n/γ) of the counter remains of the order of 100.

The results obtained are corrected for the system's dead time and normalised to the indication of the fluence monitor. They are unfolded by a version of the code SAND [2] operating on a PC. The 640 energy groups originally used by SAND have been compressed into 120, in order to reduce the processing time. The SAND program has been implemented in an environment which allows to visualize the unfolded spectrum after each iteration. The program stops when a reasonable stability of the result is reached. The unfolding code provides, in addition to the neutron spectrum and the total neutron fluence, different dosimetric quantities such as : \hat{D}_n and \hat{H}_n using conversion factors given in ICRP publication 21; $D_n^*(10)$, $H_n^*(10)$, $C_m = H_n^*(10)/D_n^*(10)$ and the effective dose equivalent, using conversion factors given in ICRP publication 51.

In a moderate field strength (≈ 100 μ Sv/h) the duration of a complete measurement, using all the spheres, is of the order of 30'; the deconvolution needs about 2' in order to get a precision on the dosimetric quantities better than 10%. The deconvolution can be monitored by visualizing the iteration steps of the spectrum on a screen.

3. Performances

The spectrometer has been calibrated with thermal neutrons at Cadarache (France), and with several monoenergetic neutron beams of energies : 8; 144; 250; 570 keV et 1,2; 2,5; 5,0; 14,8 MeV at the PTB, Braunschweig (Germany). The interpolation of the response curves between the calibration points is based on neutron transport calculations using the one dimensional code ANISN [3] and a recent condensed cross section library. The calculation has been matched to the measurement using a unique parameter, the intrinsic counter efficiency. The response functions of the spheres are presented in figure 1.

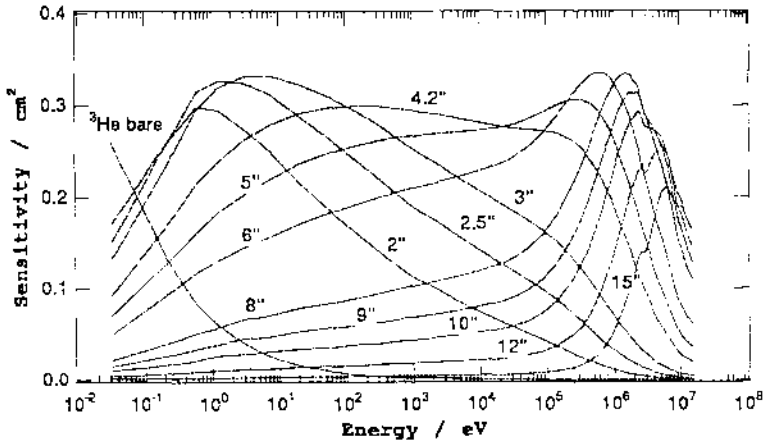

Figure 1. Response functions of the Bonner spheres

The validation of the deconvolution has been performed using the measurement in known neutron beams of americium-beryllium, californium and heavy water moderated californium sources [4]. The results obtained (examples are given in figure 2) confirm the good performances of the system, including the response matrix and the unfolding procedure.

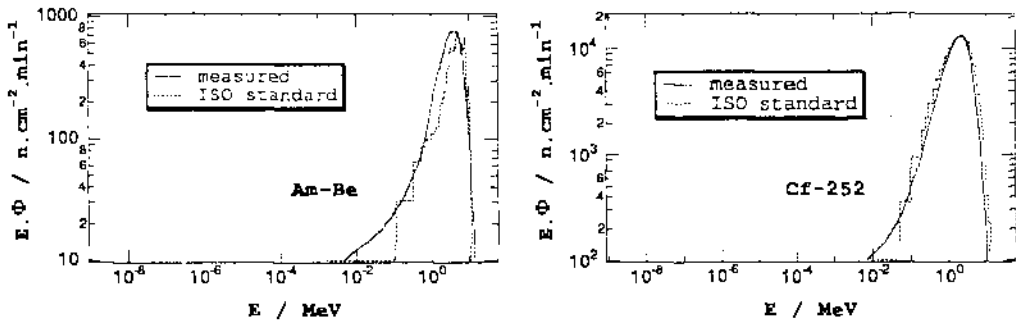

Figure 2. Comparison between the americium-beryllium and californium measured spectra and the ISO standard ones

4. Measurements of neutron fields

The system has been used in different neutron fields : nuclear power plants, medical accelerators, etc... It was not only possible to get the relevant dosimetric quantities, but also to calibrate operational instruments (rem-counters) in these fields [4]. On the other hand the knowledge of the spectrum gives a better insight into the radiation protection conditions.

In figure 3 the spectrum and the dosimetric quantities in two typical situations in a nuclear power plant are presented. The ratio of the response of the 9" sphere to that of the 3" sphere (9"/3") is given as a global indicator of the spectrum. The measurement near the entrance of the containment shows a moderated spectrum with a relatively low Q factor. The measurement performed near a transport flask presents a typical fission spectrum with hard components and a high Q factor.

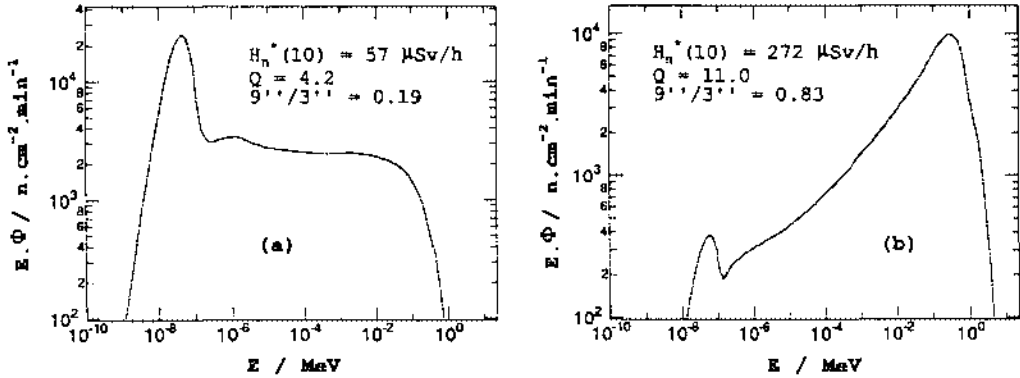

Figure 3. Examples of neutron spectra inside the containment of a nuclear power plant (a), and near a transport flask (b)

5. Conclusions

The system presented is based on a firm background consisting of a detailed calibration and a careful validation of the unfolding. The instruments are incorporated in a compact system allowing on-site evaluation. It has been successfully applied in different neutron fields as a reference instrument.

References

- [1] Vylet, V., Grecescu, M., Lerch, P., Prêtre, S. and Valley, J.-F., 1988, Multisphere measurements at several neutron facilities, Radiation Protection Dosimetry, 231, 4, 289-292.
- [2] McElroy, W.N., et al., 1967, A Computer-Automated Iterative Method for Neutron Flux-Spectra Determined by Foil Activation, Rep. AFWL-TR-67-41, Vols. I-IV, U.S. Air Force Weapons Lab., Kirtland, AFB, New Mexico.
- [3] Engle, W.W., Jr., 1967, A User Manual for ANISN, A One Dimensional Discrete Ordinates Transport Code with Anisotropic scattering, A.E.C. Research and development Report K 1693.
- [4] Aroua, A., 1991, Etude des champs neutroniques dans les centrales nucléaires et de l'influence de leur diversité sur la détermination des grandeurs de la protection radiologique, Thèse No 942, Ecole Polytechnique Fédérale de Lausanne.

FAST NEUTRON DOSIMETRY WITH CR 39 PLASTICS PLATE

T. Tsuruta and T. Niwa
Atomic Energy Research Institute, Kinki University,
3 4 1 Kowakae, Higashiosaka-shi, Osaka, 577 Japan.

Y. Fukumoto
Chiyoda Safety Appliances Co., Ltd.,
1-7 12 Yushima, Bunkyo-ku, Tokyo 113 Japan.

ABSTRACT

CR-39 detectors were irradiated with fast neutrons and etched in several alkaline solutions. An automatic image analyzer was used to obtain the density and size distribution of etch pits. When etching conditions were kept at 30% KOH, 60°C and 8h, the sensitivity was found to be 3.1×10^{-4} , 4.2×10^{-4} and 2.0×10^{-4} for neutron energies of about 1MeV, several MeV and 14MeV, respectively. The size of etch pits increased with neutron energy. The etching time could be reduced to less than one tenth as a result of a rising from 60 °C to 90°C. After due consideration of background counts, a dose of 0.2mSv could be measured with this system.

INTRODUCTION

Many types of CR 39 detectors are used for personal neutron dosimetry. Chemical and electrochemical etching are performed to enlarge latent tracks caused by nuclear reactions to etch pits. There are several methods to count the etch-pits. A lot of conditions are proposed for the etching and the counting. The energy response of the detectors depends on the combination of these conditions intensely.^{1,2)} It is important to know the energy response under adapted etching and counting conditions for accurate dosimetry.

There is a demand for shorter etching time of CR-39 detectors. Several hours or more prolonged etching time is too long to adapt for practical measurement. Generally, high temperature promotes the etching, though it has a tendency to roughen the detector surface. It is set as a goal in this study to reduce the etching time to one hour or less without enhancement in surface roughness. In this study, sensitivity is measured for three energy regions of fast neutrons under our conventional and present etching conditions.

EXPERIMENTAL METHODS

The composition of the CR 39 plates used in the present study was 97% of allyl diglycol carbonate and 3% of diisopropyl peroxy

dicarbonate. The transparent plate with a thickness of 1.6mm was sandwiched with polyethylene sheets with a thickness of 0.1mm to form a detector. The detectors were irradiated with about 1MeV neutrons from a fast neutron source reactor, several MeV neutrons from an Am-Be source or 14MeV neutrons from a Cockcroft Walton type accelerator. Irradiated neutron fluences were estimated by an activation method.

After irradiation, the CR 39 plates were separated from the polyethylene sheets, and were etched in aqueous solutions of 30 wt% of KOH or NaOH at 60-90 °C for 0.4-20h. The solution was agitated by magnetic driven vanes during etching. After etching, the plates were immediately washed clean in flowing water and dried under clean ventilation. In order to determine the amount of bulk etching, plate thicknesses were measured before and after etching by micrometer callipers.

Etch pits and the state of the surfaces were observed using an optical microscope. The etch pits were counted with an automatic image analyzer having an optical microscope, TV camera and computer. The distributions of etch-pit diameters were measured with this analyzer. The number of etch-pits on an unirradiated and etched plate was subtracted from that of an irradiated and similarly etched plate.

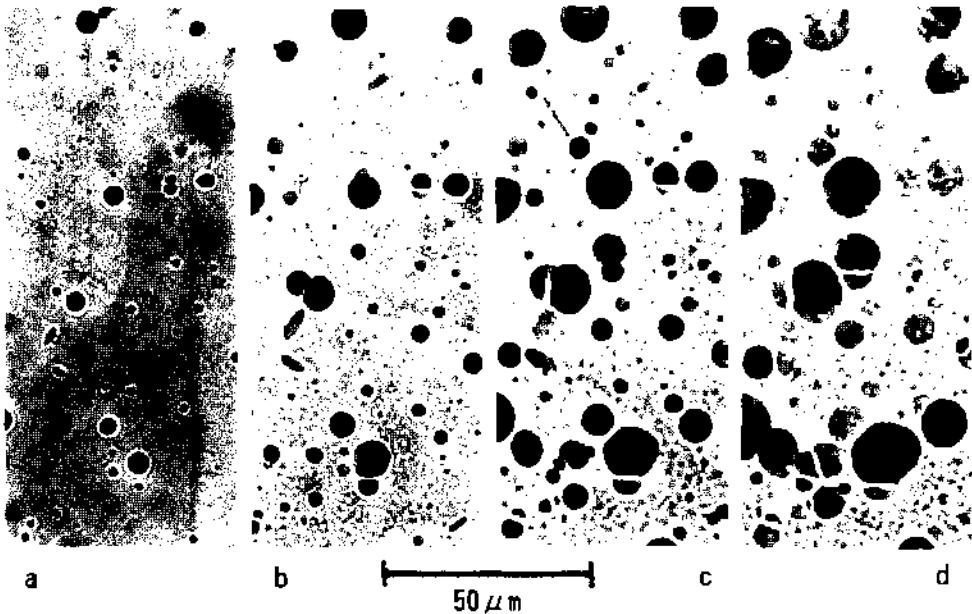

Fig. 1 Growth of etch-pits on a CR-39 plate irradiated with fission neutrons. Etching conditions : 30% KOH, 60°C. Etching time : a 4h, b 8h, c 12h, d 16h.

EXPERIMENTAL RESULTS AND DISCUSSION

Figures 1(a-d) reveal the transition in shape and number of etch pits on a plate irradiated with about 1MeV neutrons. They represent the photographs of the same area of the plate at successive stages of etching, to show how individual etch-pits generate, grow and then disappear with progress of etching. It will be noted that in the course of etching, new etch pits are continually making their appearance. The etch-pits grow in size with etching time, become easily detectable and remain so during a certain period. Beyond the certain limits of etching time, however the etch pits begin to lose their shape, which makes it difficult to avoid counting loss.

The automatic image analyzer is able to adjust the lower limit of etch pit diameter and of contrast between etch-pit's black and surface's white. The lower limit of the diameter was set for 2 μm . That of the contrast was adjusted to be able to discriminate the etch pits from the surface roughness. The number of countable etch-pits increased rapidly with etching time in the first stage of etching. However, in the prolonged etching time, the increasing rate became slow because the appearance of the etch-pits had to compensate for the disappearance. From these observations, it was found that 8-12 hours were suitable for etching time when 30% solution of KOH or NaOH was used at 60°C.

With respect to 14MeV neutrons, Fig.2 shows an increase of etch-pit density and sensitivity with etching time. The ratio of the etch

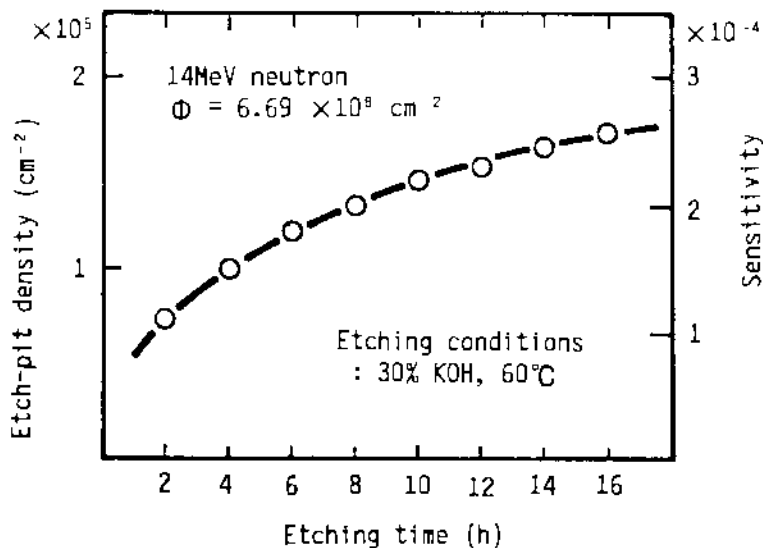

Fig.2 Increase of etch pit density and sensitivity with etching time

pit density to the neutron fluence is termed sensitivity. In the case of about 1MeV and several MeV, similar relationships were obtained. When etching conditions were kept constant, the sensitivity was the highest for several MeV, middle for about 1MeV and the lowest for 14MeV. For example, when the condition was kept 30%KOH, 60°C and 8h, the sensitivities were found to be 3.1×10^{-4} , 4.2×10^{-4} and 2.0×10^{-4} for neutron energies of about 1MeV, several MeV and 14MeV, respectively. When etching conditions were kept constant, the average of etch-pit diameter increased with neutron energy.

From the experimental results, the following formulas (1) and (2) were obtained as relationships of bulk etching rate $V(\mu\text{m/h})$ and temperature $T(\text{K})$ of etching solution for KOH and NaOH.

$$V = 3.17 \times 10^{18} \exp(-1.13 \times 10^4 / T) \quad (1)$$

$$V = 3.11 \times 10^{18} \exp(-1.12 \times 10^4 / T) \quad (2)$$

Activation energies are calculated to be 0.89 and 0.88 eV for KOH and NaOH from the formulas (1) and (2). These values agree with the value derived before.³⁾ The bulk etching rate at 90 °C is twelve times as fast as that at 60°C. The increasing rates of the sensitivity and the etch pit diameter are approximately proportional to the bulk etching rate. The etching time could actually be reduced to less than one tenth as a result of a rising from 60°C to 90°C. This increase did not change the energy response and did not enhance in surface roughness. After due consideration of background counts, it was found that a dose of 0.2mSv can be measured with this detection system. At the present time, we adopt 30% KOH, 90 °C and 1h as ordinary etching conditions for fast neutron dosimetry.

REFERENCES

- 1) Tommasino, L. and Harrison, K. G., 1985, Radiation Protection Dosimetry 10, 1 4, 207-217.
- 2) Harrison, K. G. and Tommasino, L., 1985, Radiation Protection Dosimetry 10, 1 4, 219-235.
- 3) Khan, H. A. and Khan, N. A., 1980, Nucl. Instrum. Methods, 178, 491.

ACKNOWLEDGEMENT

The authors wish to express their appreciation to Mr. T. Ichihara of the Kyoto University and Mr. K. Yoshii of the Tokyo University for their assistance in carrying out the neutron irradiation. Acknowledgment is also due to Dr. S. Durrani and Mr. I. Badr of the University of Birmingham, for helpful discussions.

**FIXED RADIATION PROTECTION CHANNELS ON EDF PWR
Gilles Champion EDF/SEPTEN F-69628 VILLEURBANNE
Jean-Marie Houin MERLIN GERIN PROVENCE BP No. 1 F-13560 SENAS**

INTRODUCTION

The power plant unit radiation protection system (designated KRT) groups together the fixed radiation protection channels designed for the radiation monitoring of a PWR in order to :

- check the condition of the various containment barriers,
- monitor the radioactive discharges into the environment,
- protect the personnel working on a PWR,
- assist the operator in an accident situation.

To fulfil all these functions with the minimum amount of different equipment items, it is merely necessary to combine about 80 different subassemblies (detectors, electronic signal shaping, ratemeters) to form the 50 channels which are installed on each EDF PWR. This modularity enables a channel to be easily tailored to the required function.

The methodology adopted by EDF and the manufacturer MERLIN GERIN PROVENCE to define the measurement subassemblies, select the sensor locations and qualify the equipment items complies with the IEC standards.

DESCRIPTION

The location of the sensors is schematically shown in the drawing hereafter.

1. Barriers

The Process Stream Radiation Monitoring channel used for the first barrier is marked (1) in the diagram (IEC standard 768).

Checking of the second barrier requires the provision of more channels sensitive enough to detect as soon as possible the presence of noble gases in the air, indicating the loss of tightness of this barrier (locations 2 and 8). This also concerns the steam system for checking the condition of the steam generator (locations 3, 4 and 5), the intermediate cooling system (6) and the condensates of the heat exchangers (7) installed in the nuclear auxiliary building. The gas channels comply with IEC project standard 45A145.

900 MW REACTOR SCHEMATIC DIAGRAMM

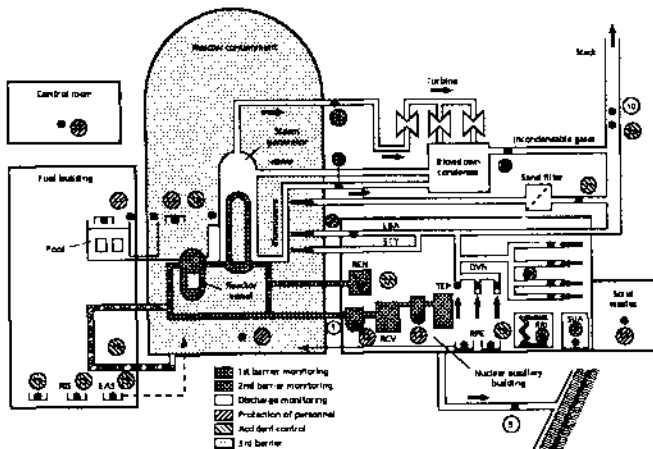

2. Discharges

The liquid discharges (9) are monitored so as to prevent release into the environment due to a handling error (IEC standard 861). The gaseous discharges (10) are monitored at the stack by means of noble gas and aerosol channels (IEC standards 761-2 and 761-3).

3. Protection of Personnel

The aerosols and iodine in the air of the containment in the plant shutdown configuration are monitored (location 2). Area monitors are used for monitoring the irradiation (IEC standards 1031 and 532) :

- above the spent fuel pool (location 11),
- due to the head filters of the RCV (reactor control volumetry) and TEP (boron recycling) systems (locations 12 and 13),
- due to the solid wastes (location 14),
- in the control room (location 15).

4. Accident Condition

The containment air (16, IEC standard 951-3), primary coolant (17, IEC project standard 45A122), sump recirculation water (13) and the sumps (19) are monitored. The gases at the stack are also monitored in an accident condition (20, IEC standard 951-3).

EQUIPMENT AND RELEVANT QUALIFICATION

The measurement channel sensors are manufactured with the application of time-proved ionizing radiation measurement techniques and mainly concern :

- scintillation detectors (mainly sodium iodide) with coupled photomultiplier,
- proportional counters, Geiger-Müller or ionization chambers (simple and differential).

The experience gained from the operation of a great amount of identical equipment items has been taken into account to improve the equipment since the start of the French nuclear program.

The EDF radiation protection Technical Specifications (TS) is the reference document which has enabled coherence to be obtained between the manufactured and installed equipment.

The TS is in coherence with the IEC general recommendations concerning the qualification of electric equipment (IEC standard 780 : Qualification of Electrical Items, and IEC standard 980 : Recommended Practices for Seismic Qualification) and those relative to radiation protection channels (IEC standard 761-1 : Equipment for Continuously Monitoring Radioactivity in Gaseous Effluents, and IEC standard 951-1 : Radiation Monitoring Equipment for Accident and Post-Accident Conditions, and IEC project standard 45 BWC9 : Centralized System for Continuous Monitoring of Radiations).

The tests intended to check the conformity of the equipment items with the TS have been conducted for fifteen years by EDF in collaboration with the manufacturer. It is to be noted that all the subassemblies integrated in the fixed channels have been tested.

DEVELOPMENTS

The development of VAMCIS indicates the course followed by EDF and MERLIN GERIN PROVENCE for the design of channels providing better performance. This channel was constantly developed as from 1985 for both the continuous measurement of leaks in steam generators and the detection of a sudden rupture of a generator tube. This channel is installed at (5) in the diagram, in contact with the steam line and upstream of the relief valve.

Its rapid development and installation on all the steam generators (SG) of the EDF PWR was made necessary by the rapid degradation of the SG tubes, the absence of a continuous measurement without sampling, sufficiently reliable and accurate to indicate the leak rates.

If the sensor is still based on a scintillating system with sodium

iodide, the electronics has greatly advanced in order to :

- analyze the signal energy per 30 keV channel. This spectrometric measurement is accurate enough to identify the nitrogen 16 peaks,
- allow for the influence parameters (nuclear power, temperature) to suppress inadvertent drifts,
- make better use of the microprocessor capabilities for converting the raw count rates (pulses per second) into leak physical units (liters/hour).

The development of new fixed radiation protection channels to be installed on the future PWRs will be conducted according to these directions so as to possess information as regards the nature of the fission products in the primary coolant and the air of the containment. This will enable the harmonious integration of the increasingly strict requirements of the Safety Authorities as regards the control of nuclear accidents.

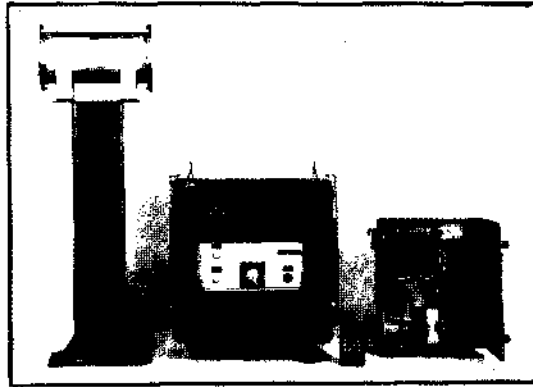

STEAM GENERATOR LEAK RATE MEASUREMENT CHANNEL - VAMCIS

CONCLUSION

The French system is installed in numerous power plants other than those of EDF, particularly the KOEBERG, ULJIN and DAYA BAY, VANDELLOS and SIZEWELL power plants. Many channels (VAMCIS, CHEG for instance) have been installed on Spanish, American and Belgian PWRs and in Slovenia.

These references provide the utmost guarantee for power plant operators as regards the availability of a dependable source for the procurement of spare parts throughout the operational life of a power plant. EDF also plays an important role by ensuring that the nuclear qualification of equipment items is maintained owing to the product surveillance system.

AN α -ACTIVITY IMAGING MONITOR SYSTEM FOR RAPIDLY DETECTING PU CONTAMINATION

Takao IIDA, Yukimasa IKEBE and Takeo NISHIYA
Department of Nuclear Engineering, School of Engineering,
Nagoya University, Furo-cho, Chikusa-ku, Nagoya 464-01, Japan

and

Takeshi OGURA and Tamotsu NOMURA
Tokai works, Power Reactor and Nuclear Development Corporation,
Tokai-mura, Naka-gun, Ibaraki-ken 319-11, Japan

ABSTRACT

A new type of α -activity imaging monitor system was constructed for rapidly obtaining the position profile of Pu contamination on filter paper. The system consists of a detector head, an image intensifier, a low-lag vidicon and an image processor. When the integrated image is taken with 10 min., PuO₂ particles more than 0.03 Bq and Pu(NO₃)₄ particles more than 0.13 Bq can be rapidly detected by spot separation processing.

INTRODUCTION

When an air monitor gives extraordinary α counts in Pu facilities, it is necessary to distinguish rapidly between Pu contamination and Rn daughters¹⁾. If the α counts are judged to be caused by Pu particles, the size distribution is an important in evaluating the inhalation exposures.

The authors constructed an α -activity imaging monitor system which was developed from the charged-particle imaging video monitor system²⁾. The present paper describes the methods for distinguishing between Pu particles and Rn daughters and estimating the size distribution of Pu particles.

IMAGING MONITOR SYSTEM

The schematic diagram of the imaging monitor system is shown in Fig. 1. The system consists of a detector head, an image intensifier, a low-lag vidicon and an image processor. The light image of α particles is integrated in the image processor. The system can display the distribution image of α particles becoming gradually clearer on a video display. The image memory consists of 512×512×16 bit words (512 k bytes). The integrated image and the processed image are stored on a floppy disk.

IMAGE PROCESSING FOR RAPID DETECTION OF PU CONTAMINATION

When the integrated image of a filter paper is taken immediately after sampling, both α spots of Pu particles and Rn daughters are observed on the image. Large Pu particles result in clearer α spots, while small Pu particles produce only a cluster of a few small α spots. Smoothing process is effective

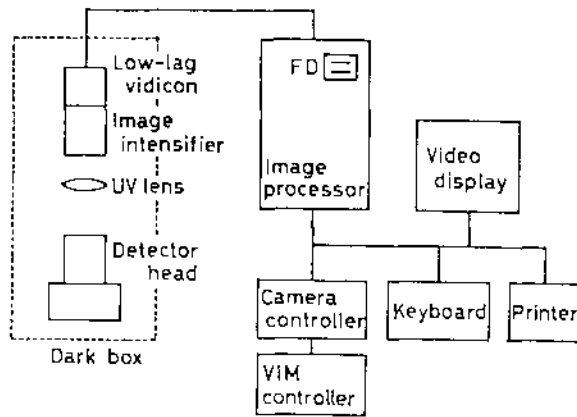

Fig. 1 Schematic diagram of the α -activity imaging monitor system.

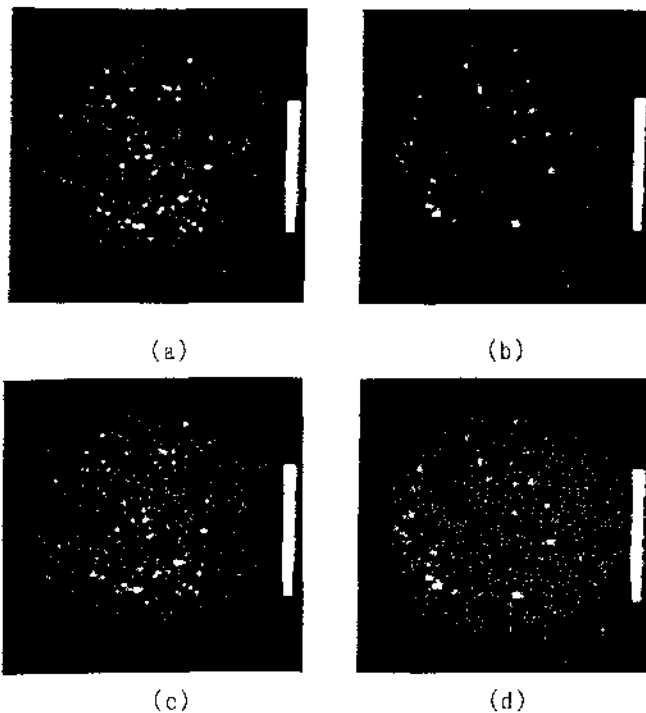

Fig. 2 Distribution images of (a) PuO_2 and (b) $\text{Pu}(\text{NO}_3)_4$ particles. Superimposed images of Rn daughters images of 1,771 counts and the images of (c) PuO_2 and (d) $\text{Pu}(\text{NO}_3)_4$ particles.

for collecting the scattering α spots into one spots.

The integrated image shows nonuniformity. To evaluate the

image quantitatively, the uniformity correction process has been carried out by using a standardized α image.

The spots of Pu particles are separated from the small spots of Rn daughters by using threshold level (TL) and separate level (SL) determined as a function of Rn daughters concentration on the filter. The values of TL and SL were decided as the probabilities that the counts of one pixel and one spot have more than TL and SL are less than 0.05, respectively.

DISTINCTION BETWEEN PU PARTICLES AND RN DAUGHTERS

The applicability of the system for distinguishing Pu particles from Rn daughters was studied by using filters contaminated with PuO_2 particles, $\text{Pu}(\text{NO}_3)_4$ particles and Rn daughters. The whole activities of PuO_2 and $\text{Pu}(\text{NO}_3)_4$ particles are 2.37 Bq and 1.60 Bq. Figures 2 (a) and (b) show the images of PuO_2 and $\text{Pu}(\text{NO}_3)_4$ particles taken with 90 and 60 min. Figures 2 (c) and (d) shows the superimposed images of Rn daughters image of 1.771 counts and the images of PuO_2 and $\text{Pu}(\text{NO}_3)_4$ particles. The Rn daughters images of 5.475 and 10.857 counts were also superimposed on the images of PuO_2 and $\text{Pu}(\text{NO}_3)_4$ particles.

Figure 3 shows the detection limits of PuO_2 and $\text{Pu}(\text{NO}_3)_4$ particles when Rn daughters are present on the filter. The PuO_2 particle of 0.03 Bq ($1.41 \mu\text{m}$: activity equivalent spherical diameter) and $\text{Pu}(\text{NO}_3)_4$ particle of 0.13 Bq ($3.43 \mu\text{m}$) may be detected within 10 min, even if Rn daughters of 2 Bq are present on the filter. The activities of PuO_2 and $\text{Pu}(\text{NO}_3)_4$ particles of 0.03 Bq and 0.13 Bq in air per 1 m^3 are lower than DAC of ^{239}Pu particle ($0.2 \text{ Bq}\cdot\text{m}^{-3}$) in air.

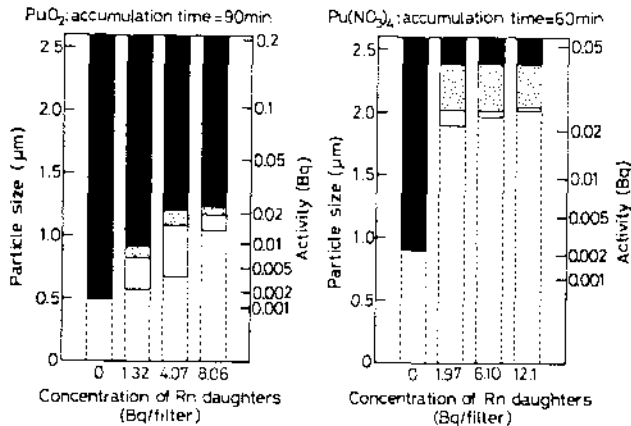

Fig. 3 Detection limits of PuO_2 particles and $\text{Pu}(\text{NO}_3)_4$ particles when Rn daughters are present on the filter.

ACTIVITY AND SIZE DISTRIBUTION OF PU PARTICLES

Radioactivity of PuO_2 particle is given by

$$D = 4.01 \cdot C \tag{1}$$

where D is PuO_2 activity (Bq) and C is the α count obtained on a uniformity-corrected image. The relation between the size and the activity of PuO_2 particle is given by

$$Y = (k \cdot D)^{1/3} \quad (2)$$

where Y is particle diameter (μm) and k is constant of 83.4 for PuO_2 particles and 319 for $\text{Pu}(\text{NO}_3)_4$ particles³⁾.

The spot count of each Pu particle in Figs. 2 (c) and (d) is converted into size by eqs. (1) and (2). The results shown in Figs. 4(a) and (b). The size of almost Pu particles is less than 4 μm .

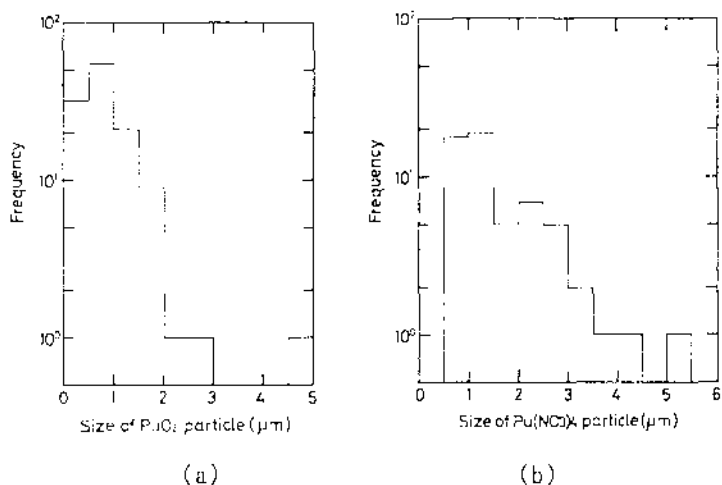

Fig. 4 Size distribution of (a) PuO_2 and (b) $\text{Pu}(\text{NO}_3)_4$ particles.

CONCLUSIONS

The α -activity imaging monitor system has good spatial resolution. The integrated image can be evaluated quantitatively by the software programs. When the integrated image is taken with 10 min., PuO_2 and $\text{Pu}(\text{NO}_3)_4$ particles more than 0.03 Bq and 0.13Bq can be rapidly distinguished from En daughters by the spot separation processing. Moreover, the size distribution of Pu particles can also be determined from the integrated image.

REFERENCES

1. Hunt, S.E., Allenden, D., Boddy, K., Cattle, B., Freck, D.V., Taylor, E.D. and Waters, D.G., 1965, The Monitoring of Uranium and Plutonium Dust Hazards: Radiological Monitoring of the Environment, eds. Godbold, B.C. and Jones, J.K., pp. 85-91, Pergamon, London.
2. Iida, T., 1988, A Charged-Particle Imaging Video Monitor System, Rev. Sci. Instr., 59, pp. 2206-2210.
3. Leary, J.A., 1953, Particle Size Determination in Radioactive Aerosols by Radioautograph, Anal. Chem., 23, pp. 850-853.

INTELLIGENT DOSE RATE DETECTORS
FOR RADIATION MONITORING IN AUTOMATIC MEASURING NETWORKS

W.Rieck, H.Faatz, J.Frowein, B.Hoffmann, M.Iwatschenko-Borho, H.Schleicher

FAG Kugelfischer, Erzeugnisbereich Strahlenmeßtechnik, Erlangen, Germany

ABSTRACT

Several gamma and neutron doserate detectors have been recently developed which are specially designed for the application in networks: All the electronic components which are necessary for an automatic measurement mode are integrated inside the detector. This also includes a microprocessor and a serial interface. On request the probe transmits the complete measurement information. Up to 32 probes can be operated in one network.

A newly developed PC program (MRP = Monitoring Radiation Program) allows to handle, present, and store the data of up to 32 intelligent probes additionally to the data of other radiation monitors.

INTRODUCTION

Automatic ambient radiation measurements require the periodic acquisition and evaluation of signals. For this purpose in conventional systems the detector signals have to be amplified, computed and translated into a computer readable format. The new FHZ 601 A intelligent dose rate detectors perform all these steps of signal processing itself by its integrated microprocessor and analogue devices. The detector delivers completely calibrated digital data via a serial interface.

DETECTOR EXAMPLE

The FHZ 601 A intelligent probe combines the advantages of modern microprocessor electronics with the excellent properties of the FHZ 600 A proportional detector [1] which is successfully in use in several measurement networks and monitoring stations. The high sensitivity and the wide measuring range have as well been fully retained as the typical angular and energy response (see fig. 1). For the FHZ 600 A proportional

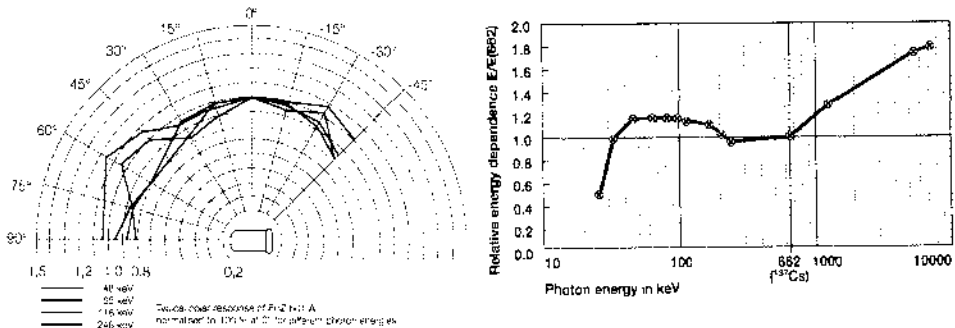

fig. 1: typical angular and energy response of the FHZ 601 A

detector as well as for the FHZ 601 A intelligent detector the approval for official calibration by German authority has been given /2/. The individual correspondence of a probe and its measuring and display instrument in a calibrated system is no longer necessary. Intelligent probes are calibrated as an independent system and can be substituted by any other one by chance without losing the calibration of the system.

THE ELECTRONICS

Modern technologies such as SMD technics, flexible printed circuits, and ASIC devices were used to build up the intelligent probe. It contains the energy filtered proportional counter, the high voltage supply, preamplifier, the whole counting electronics and an integrated microprocessor with a serial interface RS 485. The microprocessor controls the whole measurement and transmits a calibrated measuring value to the serial interface. Additionally it permanently performs self-tests for all devices and measures the operating and ambient conditions. The results are transmitted to the RS 485 interface as a status information.

The probe does not require any special display unit. For data acquisition and display a standard PC can be used. A software program for data handling in the PC is available (see below).

THE FHZ 601 A LN NETWORKS

The RS 485 interface permits the construction of local measuring networks, in which up to 32 probes can be operated from a central control station in a simple twisted pair bus system. Each probe can individually be addressed (0..31). Data transmission takes place at 2400 or 9600 bit/s via cables which may exceed even a length of 1000 m. Data transmission over distances of 3 km has successfully been tested /3/.

The measurement information is transmitted by a Level 2 protocol (ISO/OSI) listed in DIN 66348 to protect data against transmission errors. The data telegram contains not only the measured value but also an identification parameter and various status information. This telegram permits

- the identification of the source i.e. the transmitting probe
- a check of the data transfer
- a permanent control of the operating conditions and the status.

The permanent self-tests detect any ambient or operating conditions out of the normal range and report them as a status information. These tests include:

- measurement of the supply voltage for the digital electronics
- measurement of the temperature
- control of the detector amplification
- preamplifier tests by permanently injecting sets of test pulses
- control of the minimum countrate (detector failure)
- watchdog routines

Further the calibration and measuring parameters can be read out by the user and a plateau measuring routine is available that can be operated on request.

A built-in history memory stores up to 256 measuring values including time and status. The measurement is therefore independent of the connection to a central computer. On request the history data can be read out without disturbing the actual measurement.

CALIBRATION

All the calibration parameters (including two correction factors and the intrinsic background) and related information such as serial number, detector type, and software version are stored in the permanent memory (EEPROM) of each probe. The probe is calibrated at three dose rate levels. This calibration takes place once before delivery. After this initial calibration the calibration data are locked and can not accidentally be changed. For recalibration a hardware switch inside the probe has to be manipulated. Therefore by sealing the detector housing the calibration data are protected against any unauthorized changes.

THE INTELLIGENT PROBE'S FAMILY

The electronics of the FHZ 601 A is also integrated into other proportional detectors.

The probe FHZ 621 A covers the middle and high dose rate range from 50 nSv/h to 25 mSv/h. The FHZ 621 A is also PTB approved. The BIOREM FHT 750 neutron detector which uses a BF_3 proportional detector has been combined with the intelligent electronics and thus represents an intelligent neutron detector. This development allows the parallel integration of neutron and gamma detectors in the same network.

For further applications the intelligent electronics has been integrated into an ion chamber which can therefore also be used in a network together with the other detectors of the intelligent family.

MRP MONITORING RADIATION PROGRAM

As a powerful tool for analysing and interpreting the measured values a special PC-program has been designed. It allows the acquisition, storage and presentation of the measurement results from up to eight stand alone radiation monitors e.g. aerosol monitors or from up to 6 radiation monitors plus 32 dose rate probes such as e.g. the FHZ 601 A (fig. 2). According to their interactive communication with the user 3 groups of routines can be found:

1. Automatically running routines without interactive control.

These routines are automatically executed after program start up:

- The measuring values of the connected monitors and detectors are periodically acquired. Depending on preset parameters the chart of the last 1 to 31 days of the measured values is graphically displayed. Additionally another set of measured values may be displayed numerically. Fast changing values may also appear in an analogue display as a bargraph.

- Error messages from the remote monitors and exceeded alarm levels as well as transmission failures are signaled optically and acoustically.

2. Routines requiring user dialogue

Using the function keys explained on the monitor the following operations may be executed:

- Change of the time and measured value scale of the graphic display.
- Selection of the measured values to be displayed.
- Display of measured values from any time period during the last 10 months and calculating the average values of selectable regions.
- Numerical output of a complete data set for any selected time.
- Display of a protocol file containing error messages from the remote monitors and exceeded alarm levels as well as transmission failures together with the time they occurred.
- Execution of special functions e.g. control of a multi channel analyser.

All these functions do not affect the permanent data acquisition of the actual measured values.

3. Configuration Files

The preset values for the complete program (such as time period of the data acquisition, number of the monitors and detectors, scale and colours of the graphic display and many more) are stored in external ASCII files. This allows the user to modify these parameters and thus to adapt the program to new hardware configurations or to modified requirements.

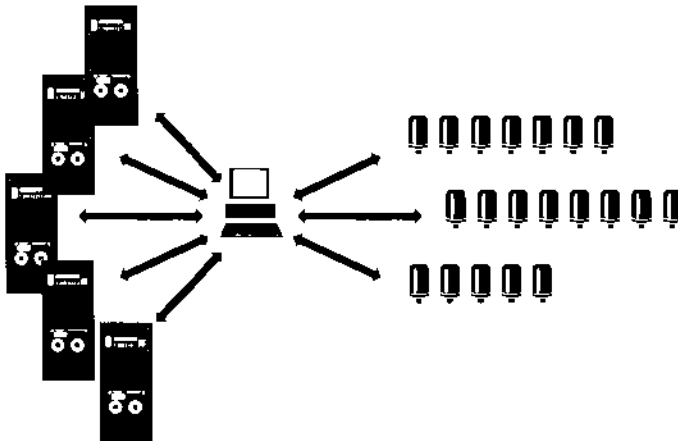

fig. 2:

Local network consisting of aerosol monitors and intelligent probes linked to a PC via MRP

- [1] Fischer, U.: Hoheempfindlicher Proportionaldetektor zur Messung und Überwachung der Umgebungsstrahlung; Detektor FHZ 600 A im natürlichen Strahlungsfeld; FAG Erzeugnisbereich Strahlenmeßtechnik, Betriebsinterner Bericht (1989)
- [2] Innerstaatliche Bauartzulassungen: PTB Nr. 6.41-06/89 B and PTB Nr. 6.41-17/90 B
- [3] B. Hoffmann et al.; Intelligente Sonde FHZ 601 A für die Ortsdosimetrie; Jubiläumstagung des Fachverbandes für Strahlenschutz e.V.; Aachen (1991)

HEALTH PHYSICS INSTRUMENTATION
A PROGRESS REPORT

R. Maushart

Laboratorium Prof.Dr.Berthold GmbH & Co.
Wildbad, Germany

ABSTRACT

Health Physics Instruments have changed rather dramatically in the past decade. On the one hand, technological innovations like Microprocessors, data storage facilities and imaging displays have altered shape, size and appearance of the classical devices, particularly the hand-held ones. On the other hand, instruments are increasingly being considered as an integral part of Radiation Protection procedures and organisations, supporting a smooth and reliable implementation of all necessary measures. This implies ease of operation, and extensive self-checking and performance control features.

Since there are different categories of users with quite different degrees of motivation and training, the measuring instruments of the future will have to be adapted to specific types of users. Instruments for "professional" radiation protection - for example in nuclear power plants and nuclear technology - will differ from instruments used in the radionuclide laboratory, where radiation protection will necessarily have to be done as a "side-job".

TODAY'S STATE OF THE ART IN THE DEVELOPMENT OF MEASURING INSTRUMENTS

The present state of the art in measuring technique can be illustrated by means of several types of instruments which are employed for important tasks in radiation protection in the medical field.

A large variety of portable doserate measuring instruments with digital microprocessor systems is available on the market. Their detector is usually a built-in miniature GM counter tube, and a more or less great assortment of external probes may be connected in addition.

Strangely enough, instruments with scintillation detectors have hardly been improved since they were introduced into the market one and a half decades ago; the technology change in electronics seems to have passed by these instruments.

Portable instruments using an ionization chamber as a detector are mainly supplied by US manufacturers. German manufacturers offer only two instruments, both rather obsolete.

Still hardly available - probably due to the low demand - are instruments capable of measuring the beta doserate.

Stationary doserate measuring systems used, for example, for the monitoring of accelerators are worlds apart from the first generation of analog ratemeters.

Usually, they operate, like the portable instruments, almost exclusively with digital result display. Moreover, they incorporate a significant intelligence, such as sliding time constants, dose integration, result storage over longer time periods, and autonomous programs for data transfer to a printer or computer, with data transfer option via bus lines.

The different energy and doserate ranges for specific applications are covered by a broad assortment of GM, proportional and ionization chamber probes.

Rem counters - which actually should be called Sievert counters - with BF_3 or ^3He counter tubes or even LiI scintillation counters as detectors in combination with large moderator spheres are still employed for the measurement of the **neutron doserate**. Alternative systems such as the "Dineutron" made by a French company, or tissue-equivalent proportional counter tubes (TEPC), whose development has been reported a number of years ago, have not been very successful so far.

Xenon large-area counter tubes in combination with pre-selectable nuclide-specific calibration factors for Bq/cm^2 display are fairly common in portable contamination monitors. Wall holding devices allow their application as semi-stationary units for exit control. Sophisticated calculation methods for determining the measured value have largely eliminated the slow reaction of the display of older ratemeter units. Background storage is a standard feature with most instruments.

Self-monitoring and test routines are also fairly common. However, some instruments appear to be "over-refined"; simple handling, an essential factor for the every-day use in the laboratory, is sacrificed to a large number of parameters which can be selected and edited by the user.

In the aftermath of accidents involving person contaminations one usually has to perform measurements under difficult conditions, such as high humidity or bad visibility. Many of our modern contamination monitors do justice to these requirements.

The external design of personal contamination monitors reflects the modern technology they incorporate. Detector contaminations are monitored, external radiation fields compensated, measurement times adapted to the statistics. Monitors for graphic, location-related result display are fairly common. Highly advanced data processing allows the build-up of a network of recording systems comprising contamination monitors, access control and a PC-based central evaluation station.

In the medical field, the measurement of gaseous radioactivity is required particularly in two areas: for the diagnostic use of the radioactive noble gases ^{85}Kr and ^{133}Xe , on the one hand, and for the room and waste air monitoring of accelerators, on the other hand. The monitoring systems used for this purpose usually still operate with large-area proportional counter tubes, occasionally also with surface layer semiconductors as detectors. The progress becomes obvious largely in the subsequently connected "smart" electronics.

Detectors used for **iodine measurement** which is more and more required and employed in room air monitoring on therapy stations did not change much over the last years. The noise reduction was improved, however. Specially designed low-noise instruments are capable of reaching sound levels around 50 db.

FUTURE TRENDS IN THE DEVELOPMENT OF MEASURING INSTRUMENTS

With regard to the measuring electronics the change in technology is largely completed. Microelectronics, surface mounting and hybrid technique, and the use of solid-state data memory affect the appearance and performance of the instruments.

With regard to the detectors, however, the technology has hardly changed in recent years, leaving aside the introduction of highest grade germanium detectors for high resolution gamma spectrometry. This will change in the years ahead.

Geiger-Müller counter tubes are still preferred for dose-rate measurement, particularly in portable instruments. Their weak points are the limited service life, in particular with high doserates, the measuring range which is limited to a maximum of 5 decades, and the inadequate sensitivity in the energy range below 40 keV.

These detectors will be replaced by very small proportional counter tubes in ceramic technology which can be employed in particular in the low energy range required in radiology.

Silicium-PIN-detectors offer another alternative to the GM counter tube, especially for low-priced instruments.

Large-area proportional counter tubes for contamination measurement will be constructed in plastic technology. This allows the simple electrical division of very large detector areas into small, separate counting elements.

Thus, position-resolution detectors for scanning extensive contaminated areas can be realized, for example as one square meter large mosaic of one hundred individual detectors with 100 cm^2 window area each.

The detectors will incorporate an integrated microelectronics including the HV supply. The counts will thus be stored in the detector unit itself and then transferred to the measuring electronics as a data package. Thick, shielded HV and pulse cables between detector and evaluation electronics will become obsolete.

Now that the instruments have become rather similar in performance, future improvements will mainly be concerned with the outer design, an aspect which indeed has often been somewhat neglected. Occasionally one can even notice quite "fashionable" trends which have not much to do with any progress in measuring technique.

All instruments, even the portable ones, will include computer interfaces. Thus, one can output data and analyze and display it on a PC; on the other hand, parameters in the instrument can be edited and test routines can be run via the PC. Complete programs may also be entered via a barcode reader.

The portable instruments show a distinct trend toward a universal electronics suitable for a variety of applications when using different detectors. Thus, the circle becomes complete, with the disadvantages apparent in the very first instruments, especially of American origin, being completely eliminated today. Set-up routines by the user have become redundant. The modern electronics identifies the respective detector and automatically defines all pertinent parameters, such as calibration factors and display units.

The performance test, the automatic comparison of current reference values with stored standard values via so-called utility programs, will become more common. The constant storage of data, for example background rates or the detector efficiency, and the presentation of time curves permits the user to assess the stability of the system and to recognize drifts or aging effects in time.

Modern data storage technology, the versatile combination and presentation offer nearly unlimited opportunities. Unfortunately, this has led to a trend to overload the instruments with fancy electronic features and thus to overtax the user's abilities by manifold operation options and program ramifications. Finding a reasonable compromise will be the goal of the development for the years to come.

Today we are in an integrative phase of radiation protection measuring technique development. The measuring task, i.e. the safe and reliable radiation protection, must determine the appearance and performance features of the measuring instruments. They will have to be more and more integrated into the process of operative radiation protection. The user interface, the interaction of instrument and user, will play therefore a dominant role in future Health Physics Instrumentation.

CHARACTERISTICS OF TWO GAMMA-RAY SURVEY METERS
USED FOR INFLIGHT DOSE EQUIVALENT RATE MEASUREMENTS

D. Regulla and J. David
GSF - Forschungszentrum für Umwelt und Gesundheit,
D-8042 Neuherberg, Federal Republic of Germany

U. Lauterbach and W. Peßara
Physikalisch-Technische Bundesanstalt,
D-3307 Braunschweig, Federal Republic of Germany

Abstract

Survey meters as developed for terrestrial environmental radiation dosimetry are recently also used for inflight measurements of cosmic radiation. In order to interpret the measured data correctly the characteristics of these instruments in a cosmic ray environment must be considered. The present investigations deal with established equipment, i.e., (a) a high pressure ionization chamber dose equivalent rate meter (Reuter-Stokes RSS-112) and (b) a scintillation dose-equivalent rate meter (Halle DLM 7908). Both equipment was applied during an extended GSF research programme in 1990/91 on "Radiation Exposure of Civil Aircrews and Passengers" on board of passenger aircraft of Lufthansa German Airlines (Boeing 747-400) for the major intercontinental flight routes.

The equipment was studied with respect to the following characteristics: Inherent background; linearity of the readings in low dose rate photon fields; response to cesium 137 gamma rays, high energy photons, high-energy charged particles and neutrons.

It is shown that each parameter may, under laboratory conditions, lead to significant differences in the dose equivalent rates as indicated by the two instruments. After evaluation and application of appropriate correction factors however the dose equivalent rates can be brought into good agreement. For completeness, the influence of the proposed corrections on the dose equivalent rates is quantified for cosmic ray field conditions as found on flight altitudes during the GSF inflight programme.

MULTI-COUNTER SYSTEM FOR LOW LEVEL MEASUREMENTS OF ENVIRONMENTAL SAMPLES

H.Schlösser, U.Engel, R.Ringling, M.Iwatschenko-Borho

FAG Kugelfischer, D-8520 Erlangen,
Frauenauracherstr. 98, Germany

ABSTRACT

A new multi-counter system for the measurement of environmental samples is described. The system measures simultaneously alpha and beta contaminations down to the mBq range with high accuracy. Up to 12 samples can be measured simultaneously. Individual counting times can be used and samples can be changed without disturbing the measurement of the others.

INTRODUCTION

For the measurement of environmental samples like soil, air filters or smear-tests, FAG Kugelfischer developed a variety of different detector systems^{1,2,3} during the last years. Routine measurements are usually done by automatic sample-changers or by manually operated multi-counter systems. Especially in the case of very long counting times with a great amount of samples the use of multicounter systems is advantageous. Additionally multi-counter systems are very helpful instruments, in case of incidents with a need to have a quick information about the collected samples, because they have a higher throughput as single automatic systems.

Recently we developed a new multi-counter system FHT 770 T to measure simultaneously the low level alpha and beta contamination of 6 or 12 samples. Thus it is possible to perform the measurement 6 or 12 times faster compared to a single system. Furthermore the simultaneous measurement of alpha and beta contaminations saves an additional factor of 2.

THE MULTI-COUNTER SYSTEM FHT 770 T

The FHT 770 T shown in Fig 1. is designed for laboratories in the nuclear, chemical, pharmaceutical or research industry, for analysis of foodstuff and for the use in the field of general health physics.

The system consists of the detector assembly, the lead shielding and the electronics with preamplifier, high voltage generator and counters. These components are placed in the shown box. The dimensions of the box are 615 x 650 x 455 mm³ for the 6 sample version or 615 x 650 x 530 mm³ for the 12 sample version. The total weight is approximately 950 kg or 1200 kg respectively. The system includes 3 or 6 manually operated sample slides each provided with two measuring positions with 60 mm diameter and a maximum depth of 8 mm.

The detector assembly uses 6 or 12 single proportional gas-flow counters, designed for the use with Ar-Methane 90/10 gas or Ar-CO₂ 82/18 gas. Every 6 counters are guarded by a large area proportional counter to suppress the cosmic-ray background by using an anticoincidence technique. Each counter is provided with <0.5 mg/cm² gold coated polyester window with a diameter of 60 mm.

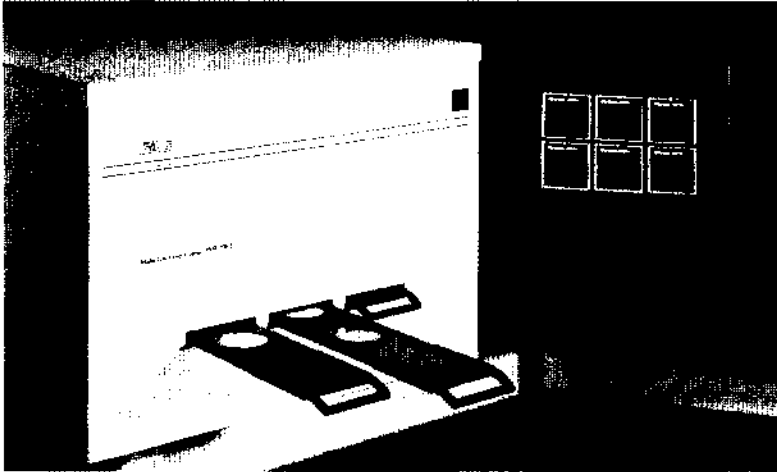

Fig. 1 Photograph of the multi-counter system for 6 samples

The use of multi-wire technique gives a small variation of the detection efficiency over the detector surface. The detector assembly is surrounded by a lead shielding of 100 mm thickness to reduce the ambient background radiation.

The electronic system is shown as a block diagram in Fig 2.

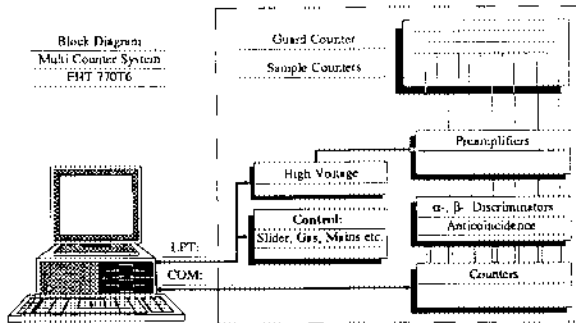

Fig 2 Block diagram of the electronics of the FHT 770 T

The signals produced by alpha- or beta-particles in the FHT 770 T are amplified by the preamplifier module and fed to discriminators which distinguish between alpha and beta signals. An anticoincidence circuit eliminates the background produced in the counters by cosmic radiation. The remaining signals are fed to counters which are controlled via one serial port by a personal computer. The high voltage of the detectors can be set by the PC via one parallel port. The control module gives information about the actual sample slide position and controls the automatic gas supply unit, which supply the detectors with gas and protects them against overpressure.

For operation of the measuring system, an IBM compatible Personal Computer is required which must be fitted with at least one serial and one parallel interface. In addition, a graphic card is necessary. A second parallel interface is required for an optional printer unit.

The measurement is controlled by a software which permits input of the most important measurement parameters, such as measuring time, nuclide, sample-id, etc., for each sample-position individually. The measurement is started after loading the samples by moving the slides into the measurement position. The measurement is finished when either a preset time, a preset count or an preset statistical accuracy is reached. When a sample slide is opened during measurement the counting for two samples is stopped. When the slide is reclosed subsequently, the interrupted measurement can either be resumed or a new measurement is started. Measurement of the other samples is unaffected thereby.

A test routine running permanently checks the detector amplification and the counting gas supply. If any significant shift in the operating points or a malfunction in the counting gas supply is detected, the system issues a warning.

The results of the measurement are stored in data-files and can thus be processed in other software programs. It is possible to quit the measurement program at any time, for example for an analysis of the measured values. After reentering the program, the data accumulated meantime are included in processing, without any loss.

FHT 770 T CHARACTERISTICS

The FHT 770 E is suitable for detection of very low alpha and beta contamination. The relevant parameters of low contamination A_{min} measurement are the measurement time t , the background n_0 and the efficiency η of the measuring assembly, according to the known formula

$$A_{min} = k \cdot \sqrt{n_0} / t \cdot (1/\eta)$$

where k represents the statistical error in terms of sigma.

In order to get a low background counting rate it is necessary to have a well designed sample-guard-counter geometry and an efficient anticoincidence circuit. In addition thoroughly selected detector and shielding materials should be used.

The variation of the background rate during long term measurement is shown in Fig 3, where subsequent background measurements over 100 min intervals are shown. The mean value for the beta background for all 6 detectors is 0.52 ± 0.08 cpm. The background variation of the individual detectors is statistically not significant within the 3 sigma level.

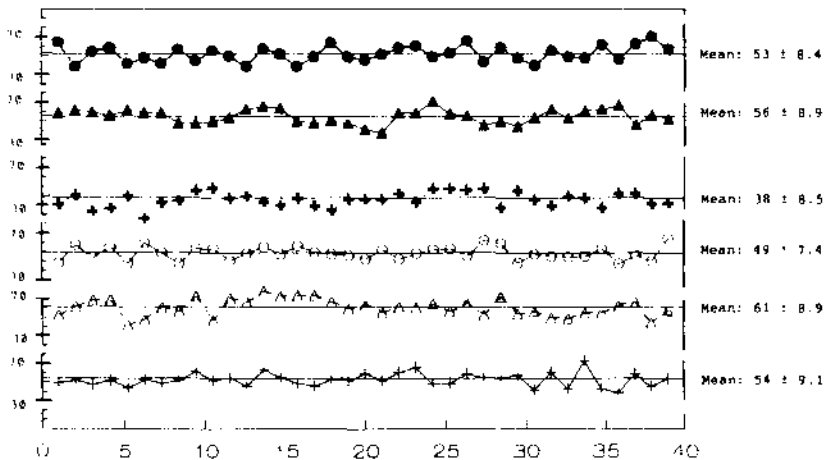

Fig. 3 Subsequent 100 min measurements of beta background

The FHT 770 T is calibrated for different nuclides and different sample sizes, the corresponding values for the detection efficiencies (in %) are shown in Table 1.

Table 1 Calibration data FHT 770 T

Nuclide	Planchet Ø 60 depth [mm]		Planchet Ø 30 depth [mm]	
	3	8	3	8
⁶³ Ni	7.7	3.3		
¹³² Ba	16	10	10	7.9
¹⁴ C	27	19		
⁶⁰ Co	28	22	33	28
¹³⁷ Cs	41	34	47	39
²⁰⁴ Tl	37	30	42	39
⁹⁰ Sr/ ⁹⁰ Y	42	34	51	41
²⁴¹ Am, α	28	21	32	25
²⁴¹ Am, β	9.4	6.1	11	8.7
²¹⁰ Po			40	32
geom. 100%	36	28	42	34

The radioactive sources are standard calibration sources in aluminium or stainless steel planchets. The activities are known within an accuracy of 10 %, the additional statistical errors are below 1%. The values for ⁹⁰Sr/⁹⁰Y refer to ⁹⁰Sr. Values above the geometric limits given by the source detector geometry are induced by backscattering effects.

The efficiencies decrease about 20 % by changing the distance from source to counter

from 4 to 9 mm. For the low beta energy sources, there is a decrease of about 60 %. The use of samples with 30 mm diameter in the center of the 60 mm counter gives an reasonable increase of the detection efficiency of about 15 % because of geometrical effects (solid angle and outer zones of the detector). The minimum detectable contamination in 1 hour measuring time is according to the above stated formula within an accuracy of 3 σ e.g. for ¹³⁷Cs in the order of 10 mBq.

The cross talk from alpha particles into the beta channel is < 3% measured with ²¹⁰Po and the value for beta in alpha is < 0.1 % for the above stated beta sources.

The crosstalk between neighboring detectors measured with ⁶⁰Co is less than 5·10⁻⁴, for alpha and beta emitting nuclides there is no considerable cross talk.

CONCLUSION

The new multi-counter system FHT 770 T shows extremely low and stable background counting rates: <0.35 cpm for alpha-particles and 0.5 to 0.7 cpm for beta particles. In order with the excellent counting efficiencies of the multi-detector device simultaneously up to 12 samples can be measured. Thus the fast and accurate measurement of even a great number of environmental samples with very low detection limits can be performed.

REFERENCES

- 1 Automatic Sample Changer FHT 770 R, FAG Strahlen-Meßtechnik, MP-048-900124E, Issue:1/90
- 2 FHT 770 N for the determination of Alpha- and Beta-Contamination, FAG Strahlen-Meßtechnik, MP-052-900206E, Issue:2/90
- 3 Measuring Assemblies FHT 770 K and FHT 770 S with Manual Sample Changer FAG Strahlen-Meßtechnik, SM 41225E, Issue: 6/90
- 4 Multi-low-level-counter FHT 770 T, FAG Strahlen-Meßtechnik, ZT-052-0891, Issue:6/91

THE RESPONSE OF CONTAMINATION MONITORS TO NEARLY 600 RADIONUCLIDES

M. Heinzelmann^{*)} and G.H. Schnepel^{**)}

^{*)} Forschungszentrum Jülich,
W-5170 Jülich, Bundesrepublik Deutschland

^{**)} Bundesamt für Strahlenschutz,
W-5300 Bonn, Bundesrepublik Deutschland

ABSTRACT

The response of contamination monitors to 589 nuclides and 44 nuclide mixtures was calculated using large-area proportional counters. Calculations were carried out for two different types, portable contamination monitors and foot detectors of hand/foot monitors. The aim was to determine those radionuclides for which surface contaminations at the level of the area contamination limits applicable in the Federal Republic of Germany can be detected. Portable devices can detect with a measuring time of 10 s contaminations at the limit level for 434 nuclides (74 %) and 41 nuclide mixtures (93 %). This is only possible for 325 nuclides (55 %) and 32 nuclide mixtures (73 %) using the foot detectors of hand/foot monitors.

INTRODUCTION

Large-area proportional counters are generally used in the Federal Republic of Germany for contamination checks at the exit of a controlled area. The surface contamination on objects, clothes and underwear must not exceed stipulated limits. Outside monitored plant areas (Betrieblicher Überwachungsbereich) these limits, averaged over a surface of 100 cm², are 0.05 Bq · cm⁻² for α -emitters with an licencing limit of 5 · 10³ Bq, 5 Bq · cm⁻² for β -emitters and electron capturers with an licencing limit of 5 · 10⁶ Bq, and 0.5 Bq · cm⁻² for other radionuclides [1]. Since no limit values are defined for persons, the above limits are generally also applied to them. The aim was to determine those nuclides for which surface contaminations at the limit level can be detected [2]. For this purpose, the response of contamination monitors and the minimum response required for the detection of a contamination at the limit level must be known. The minimum response required depends on the background and measuring time.

EQUIPMENT

Two different detectors were examined: portable contamination monitors and the foot detectors of hand/foot monitors. The detector of portable contamination monitors is a relatively small, highly sensitive detector with a surface area of 150 to 200 cm². The response of devices from different manufacturers is not very different. The foot detector of hand/foot monitors is least sensitive since it is covered by a grate. The detector surface of the foot detector is 600 cm².

Due to this large detector surface, the detector background is larger than that of portable contamination monitors. The detector voltage of large-area proportional counters can be adjusted so that either only α -radiation or α - and β -radiation are detected. Large-area proportional counters generally use hydrocarbons as the counter gas. The detector response to photon radiation is therefore small.

RESPONSE CALCULATION

The response R of a contamination monitor equals

$$R = \frac{n - n_0}{A} = \frac{n - n_0}{a \cdot F} \quad (1)$$

wherein: n = count rate
 n_0 = background count rate
 A = activity of the radionuclide to be measured
 F = contaminated surface area
 a = A : F = activity per area of contamination

Calculations of the response to 589 nuclides are based on values measured for 22 nuclides [2]. Assuming only one β -spectrum component or one energy of the conversion electrons or α -rays, these values were taken to determine the response as a function of the energy (Figs. 1 and 2) as a good approximation to experimental results. Below the lowest energy measured the response was equated to zero. Above the highest energy measured a constant response value was assumed. The response to photon radiation is smaller or equals 0.007 s⁻¹Bq⁻¹. Based on these assumptions and on the decay data specified in ICRP 38 [3] the contamination monitors' response to 589 radionuclides and 44 radionuclide mixtures was calculated both for the detection of α -rays only and for the detection of α - and β -rays. The half-life of the nuclides selected is greater or equals one hour. All important longer-lived radionuclides are covered by this investigation. For nuclides with short-lived radioactive daughter products (half-lives below one hour) the response was calculated for the nuclide mixture assuming radioactive equilibrium.

MINIMUM REQUIRED RESPONSE

The minimum response, R_{min} , required for the detection of a contamination, a, according to German DIN standards [4] is:

$$R_{min} = \frac{3.3}{F \cdot a} \left(\sqrt{\frac{n_0}{t}} + \frac{3.3}{t} \right) \quad (2)$$

Equation (2) assumes that the detector pulses are counted during the measuring time t. Furthermore, a 5 % error probability is assumed for classifying an uncontaminated surface as contaminated, and a 5 % error probability for classifying a contaminated surface as uncontaminated. R_{min} was calculated for different background values, n_0 , and for contaminations at the different limit levels for a measuring time of t = 10 s and a surface F = 100 cm². The background

assumed for portable contamination monitors was $n_0 = 0.03 \text{ s}^{-1}$ when measuring only the α -rays and $n_0 = 6 \text{ s}^{-1}$ when measuring the α - and β -rays. The background assumed for hand/foot monitors was $n_0 = 0.1 \text{ s}^{-1}$ when measuring only the α -rays and $n_0 = 18 \text{ s}^{-1}$ when measuring the α - and β -rays.

The minimum required response calculated according to (2) was compared with the response values calculated for the individual nuclides and nuclide mixtures.

RESULTS AND DISCUSSION

Contaminations at the level of the above specified limits can only be detected with portable contamination monitors for 434 nuclides (74 %) and 41 nuclide mixtures (93 %) of the 589 radionuclides and 44 radionuclide mixtures under consideration. The foot detector of hand/foot monitors can only detect such contaminations for 325 nuclides (55 %) and 32 nuclide mixtures (73 %). The specific results for all nuclides will be published in a detailed report [2]. Contamination detection is difficult, in particular, for K-capturers, pure γ -emitters and low-energy α - and β -emitters. For example, contaminations at the level of $0.5 \text{ Bq} \cdot \text{cm}^2$ cannot be detected using contamination monitors for α -emitters with energies below 4 MeV and β -emitters with average energies below 30 keV. For many α -emitters with the low limit of $0.05 \text{ Bq} \cdot \text{cm}^2$ it is difficult to detect contaminations at the limit level.

The results presented here give a survey of the state of the art concerning the direct detection of surface contaminations. Calculated response values can slightly deviate from actual values in specific cases. If the calculated response value is only slightly below the minimum response required, contamination checks are possible by prolonging the measuring time. Contamination monitoring is possible for certain nuclides using special procedures. Contaminations occurring in nuclear power stations due to low-energy K-capturers (e.g. Cr-51, Mn-54, Fe-55, Zn-65) can be detected, for example, using large-area proportional counters with xenon or argon-methane as the counter gas. Other suitable methods of contamination monitoring are available for objects (e.g. wipe test). If it is not possible to monitor the limit value using contamination monitors, technical or organizational precautions must prevent contamination from spreading.

REFERENCES

1. Verordnung über den Schutz vor Schäden durch ionisierende Strahlung
Neufassung der Strahlenschutzverordnung
BGBl.I. p. 1321, 1989
2. Heinzelmann, M. and Schnepel, G.H.
KFA Report, in preparation
3. ICRP Publication 38
Radionuclide Transformations
Annals of the ICRP, 11-13, 1983

4. Nachweisgrenze und Erkennungsgrenze bei Kernstrahlungsmessungen; Zählende Messungen ohne Berücksichtigung des Probebehandlungseinflusses
 German Standard DIN 25482 Part I, 1989

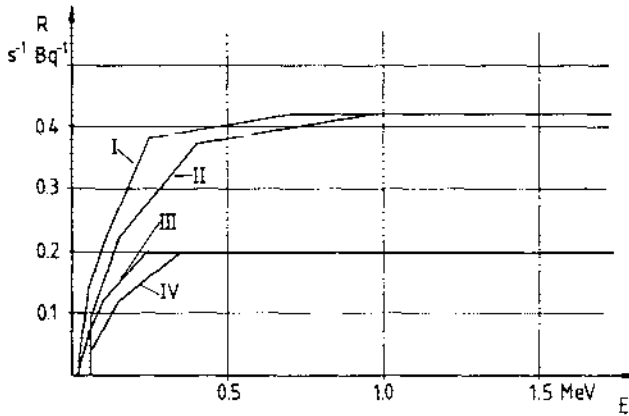

Figure 1: Response R of contamination monitors as a function of the average energy of β -radiation or the energy of conversion electrons

- I - portable contamination monitors; β -radiation
- II - portable contamination monitors; conversion electrons
- III - foot detector of hand/foot monitors; β -radiation
- IV - foot detector of hand/foot monitors; conversion electrons

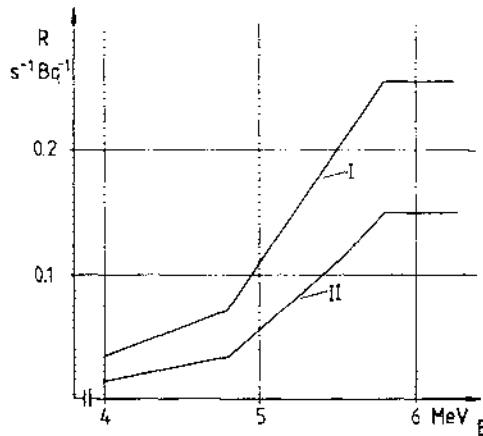

Figure 2: Response R of contamination monitors as a function of the energy of α -radiation

- I - portable contamination monitors
- II - foot detector of hand/foot monitors

A New CAM System on the Basis of Proportional Counter Tubes

Dr. E. Frenzel
EG&G Berthold, Wildbad, Germany

CAM systems using proportional counter tubes in combination with the AERD technique are capable of determining 1 DAC value within one hour with a high statistical safety. Air flow rates of up to 30 cfm are possible.

Introduction

When handling plutonium and other actinides, the air-borne particulate activity concentration has to be monitored to ensure optimum safety at the workplace. Lowest activity concentrations (DAC values of 40 mBq/m^3 relative to plutonium-239 = $1 \times 10^{-12} \text{ } \mu\text{Ci/cc}$) must be detected within a few hours with a high statistical safety. Usually one uses CAM systems with silicon detectors for this task. For construction reasons, however, only small dusting units can be realized, which limits the air flow to a few m^3/h (= 1 cfm).

The new CAM Monitor LB 150 RD designed by EG&G Berthold operates with large-area proportional counter tubes to ensure an extremely reliable measurement of the DAC values as well as a high representativity concerning the sample quantity (nearly $50 \text{ m}^3/\text{h}$ = 30 cfm).

The AERD technique (1) (2) (3) eliminates virtually all interference factors, such as background fluctuations, dustloading on the filter, and a high ambient gamma level.

The Principle of Measurement

The acronym AERD stands for Alpha Energy Range Discrimination, a method utilizing the relationship of α energy and range (4). It is well known that all natural air-borne alpha emitters which are daughter products of the noble gases ^{222}Rn ("radon") and ^{220}Rn ("thoron") show alpha energies above 6 MeV. On the other hand, all relevant plutonium isotopes as well as ^{241}Am and other transuranics have energies below 5.5 MeV. This fact is the physical basis of a large variety of commercially available monitors utilizing the advantages of the excellent spectroscopic properties of semiconducting detectors.

At the end of the eighties, Frenzel and Kreiner have taken up this idea to create a suitable measuring method, the alpha energy range discrimination method. The essential aspect of the AERD technique is a detector system which allows the selection of alpha sources with energies of $\alpha > 6 \text{ MeV}$ and $\alpha < 6 \text{ MeV}$ in combination with an air flow up to $50 \text{ m}^3/\text{h}$.

This application uses a two-detector system of flow-type proportional counters. In this case, however, the separation foil between the counter tubes is dimensioned such that low-energy alpha particles (artificial) can be detected in the bottom counter tube and high-energy alpha particles (natural) in the bottom and center counter tube. Through calibration and optimization one can reach an ideal cut of approx. 5.8 MeV with this detector configuration. By means of a simple coincidence stage for the alphas of the two tubes, the alphas can easily be identified as natural alphas and distinguished from artificial alphas. Oblique running high-energy alpha particles can be detected in addition in the bottom counter tube by means of a simple pulse height analyzer mechanism.

Description of the Monitor

A powerful side-channel blower ($50 \text{ m}^3/\text{h} = 30 \text{ cfm}$) aspirates the air through a $200 \text{ mm } \varnothing$ glass fiber filter located on a sinter metal support. The detector, a proportional sandwich counter tube with suitable separation foil for high and low-energy alphas, is located directly above the dusting unit. The charge-sensitive preamplifier with built-in coincidence and anticoincidence module is located directly on the counter tubes. The data logger LB 5310 is employed for evaluation; this unit includes all common interfaces used in nuclear technology.

All components are housed in a mobile 19" rack. The air flow required for calculation of the respective activity concentration is measured and calculated on-line. Since proportional counter tubes operate in the alpha plateau, no lead shielding is required (see Fig. 1).

Performance Features

A high air flow rate is imperative for achieving a high representativity of the measurement. Using the glass fiber filter and large-area proportional counter tubes one can realize a flow rate of $50 \text{ m}^3/\text{h} (= 30 \text{ cfm})$. The high efficiency of the detectors together with the high air flow rate guarantee an excellent statistics, which, as a consequence, results in a virtually negligible false alarm rate and an extremely low detection limit. The typical properties of proportional counter tubes, i.e. the fact that the efficiency curve is hardly dependent upon the alpha energy, ensure a consistent sensitivity of the monitor not only for plutonium-239 but also for plutonium-238 and uranic isotopes.

Dustloading is no problem for the AERD monitor, since the AERD compensation factor (the ratio of counting data of both detectors) is directly proportional to the air flow rate. A change in the air flow rate, on the other hand, is directly proportional to a change in the dustload on the filter; by measuring the flow rate, the correct compensation factor is determined and used. Since all alpha energies $< 6 \text{ MeV}$ are measured in the bottom counter tube, the problem of shifting thresholds and drifting ROI's does not exist for the AERD monitor.

Moreover, AERD monitors are easy to calibrate, so that recurring tests at site can be carried out within a few minutes.

As many experiments and measurements have shown, the AERD compensation factor does not change with varying radon or thoron activity concentrations or their fluctuations, so that this method may also be employed with success under difficult conditions, such as frequently changing ventilation conditions, fluctuating levels and dust-loaded air (see Fig. 2).

Conclusions

The combination of the semi-spectroscopic analysis with a high-volume technique has resulted in a monitor which is highly capable of mastering difficult measuring tasks. CAM monitors operating according to the AERD method are capable of determining a DAC hour with a very high statistical accuracy within a very short time. CAM monitors can be employed in any situation where air-borne alpha activity concentrations need to be monitored.

References

- (1) R. Maushart, H. Kiefer: Radiation Protection Measurement, Pergamon Press, Oxford, New York, Toronto, Sydney, Braunschweig, First edition 1972.
- (2) E. Frenzel: A new concept for an alpha-in-air low level monitor, Proceedings 20. Jahrestagung des Fachverbandes für Strahlenschutz e.V., FS-87-44-T, Basel 1987.
- (3) E. Frenzel, H.-J. Kreiner u.a.: Immissionsmessung von künstlichen Alphaaktivitätskonzentrationen mit einem AERD-Monitor, Atomwirtschaft 34, S. 498, Oktober 1989.
- (4) E. Frenzel, R. Maushart, P. Nemecek, H.-J. Kreiner: Measurement of Concentrations of Alpha Activity Using the ABPD and AERD Techniques, ANS Winter Meeting, San Francisco, CA, Nov. 10 - 14, 1991.
- (5) General Literature:
 R. Winkler, E. Frenzel, H. Rühle, J. Steiner: Rapid Methods for the Analysis of Plutonium and Other Actinides in Environmental Samples, Report of an Ad-hoc Study Group of the Working Group on Environmental Monitoring (AKU), Publication Series Progress in Radiation Protection, FS-90-51-AKU, ISSN 1013-4506, November 1990.

Acknowledgements

The author would like to give special thanks to Art Isham, H.-J. Kreiner, R. Maushart and P. Nemecek. (all EG&G Berthold) for their support and counsel.

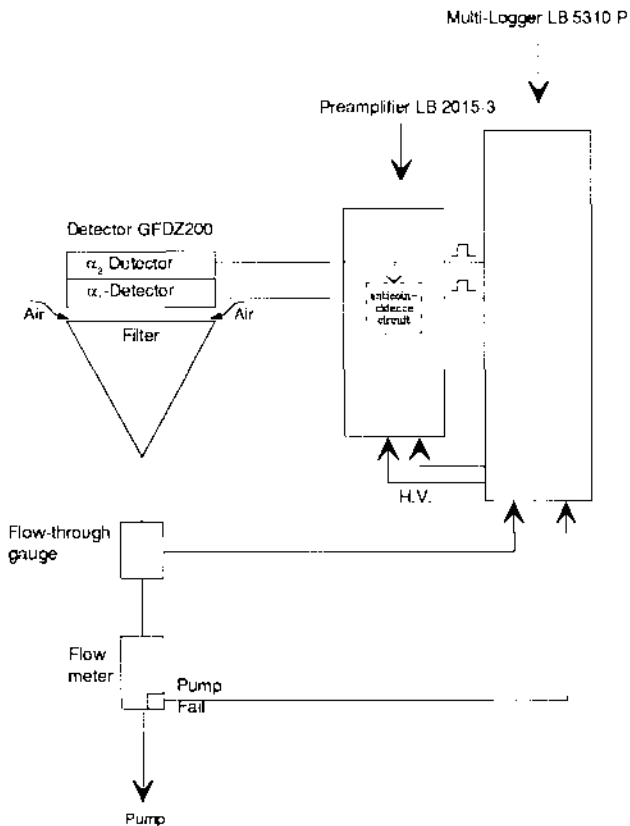

Fig. 1: Function diagram of the AERD-CAM-System

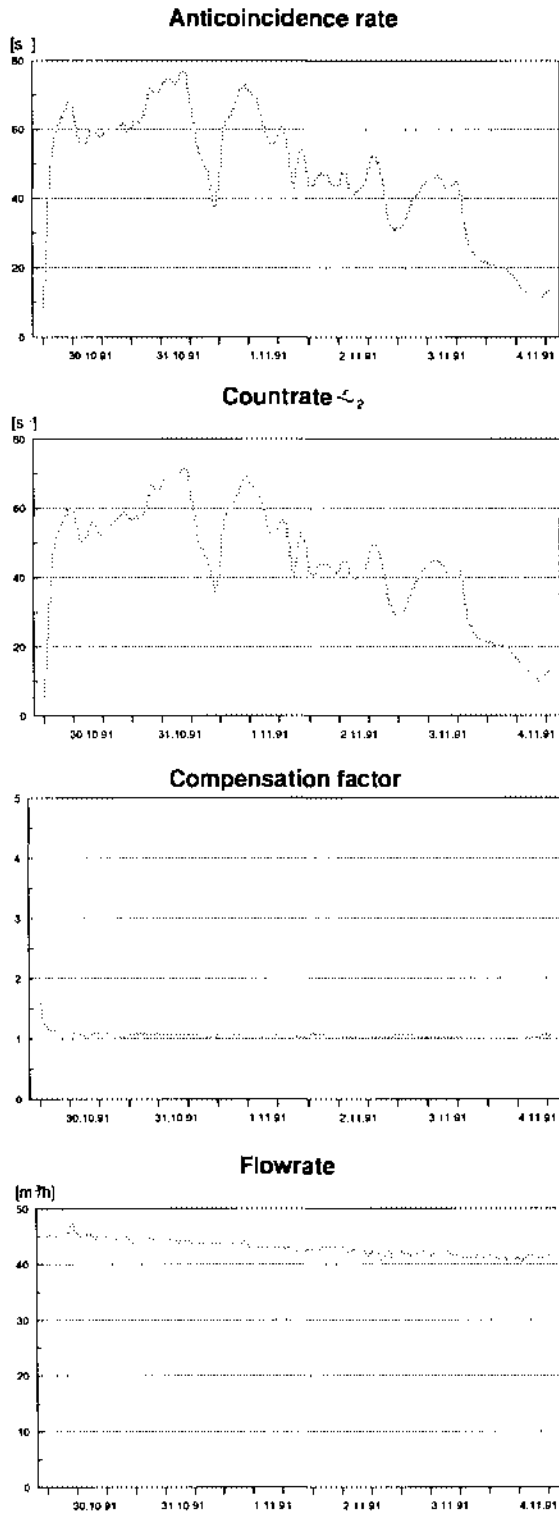

Fig 2. shows from top to bottom the curves of the anticoincidence rate, the alpha, counter tube rate (directly proportional to the natural activity concentration), the compensation factor and the flowrate

POSSIBILITIES OF THE MICROELECTROPHORESIS TECHNIQUE FOR THE
ASSESSMENT OF RISK AT LOW-DOSE IRRADIATION

I.V.Filippovich, V.A.Tronov, M.F.Denisenko, T.M.Alfyerova,
S.V.Grinko

Laboratory of Molecular Radiobiology, Institute of Biophysics
U.S.S.R. Dept. of Health, Moscow 123182, U.S.S.R.

ABSTRACT

The heterogeneity of lymphocytes in the amount of pre-existing (spontaneous) and radiation-induced DNA lesions is demonstrated using the modified microelectrophoresis technique. Irradiation of lymphocytes at 1 cGy leads to two-fold decrease in the amount of pre-existing DNA lesions 2h later. Therefore the beneficial effect of adaptive irradiation of cells is probably explained by the inducing of the repair mechanism that makes the lymphocytes less susceptible to the subsequent exposure.

INTRODUCTION

The risk of appearance of the delayed effects of radiation and other toxic agents on living cells is determined by their ability to repair DNA lesions. In turn the efficiency of DNA damage repair depends on the organization of chromatin structure and somewhat determined by the level of pre-existing (spontaneous) DNA lesions. The methods currently used to measure both the pre-existing and induced DNA damage can provide a measure of average response of the cell population according to the damage and its repair. The evaluation of pre-existing DNA lesions (recognizable by endonucleases) includes their transformation into single strand breaks (ssb) at the sites of lesions during the incubation of cells with DNA-repair inhibitors: 1- β -D-arabinofuranosylcytosine (ara-C) and hydroxyurea (HU). Thus the incubation of unirradiated cells with these inhibitors leads to their death because of double strand breaks in DNA formed as a result of ssb accumulation in opposite DNA strands. Therefore the rate of death will depend on the level of these pre-existing lesions (1,2). Recently various modifications of microgel electrophoresis technique were described which allow visualization of DNA damage and repair in individual cell (3-5). We have modified the microgel electrophoresis technique to improve the sensitivity in the evaluation of DNA damage in the single cell (lymphocyte) (6). This modified technique can provide with the most important information: whether all cells within a given population show equal amount of pre-existing DNA damage, and whether they repair the induced DNA lesions at the same rate. We have also shown that our technique of the determination of pre-existing DNA lesions in the bulk of cells permits the evaluation of the effect of irradiation at a dose as low as 1 cGy on DNA-repair functioning.

EXPERIMENTAL MEASUREMENTS

Rat blood lymphocytes and thymocytes were isolated and incubated without or with ara-C (0.1 mM) and HU (4 mM) according to the routine procedures and the number of dead cells after incubation was determined by staining. For single-cell technique measurements the cells were embedded in low melting agarose (1%) on the microscope glass slides pre-coated with 0.1% agarose, and after gelling at 4°C for 5 min were lysed in neutral salt-detergent solution (1 M NaCl, 200 mM EDTA, 200 mM Tris-HCl pH 8.0, 0.5% Triton X-100, 0.5% Sarcosyl) containing proteinase K (100 µg/ml) and ethidium bromide (20-40 µg/ml) at 20°C for 30-40 min. Electrophoresis of DNA was performed for 5 min at 5 v/cm. By use of microdensitometric system connected with computer the size of the "tail" (L) and quantity of migrated DNA (S) for single cell and the distribution of these parameters among the cells in population were determined. Cells were irradiated at a dose rate of 1.6 Gy/min by placing them in the centre of a ⁶⁰Co source, and the absorbed dose was determined with ferrous sulphate dosimetry.

RESULTS

Our modification of microelectrophoresis technique permits to increase its sensitivity and use the relatively low doses of radiation as compared with previously published results (Fig. A).

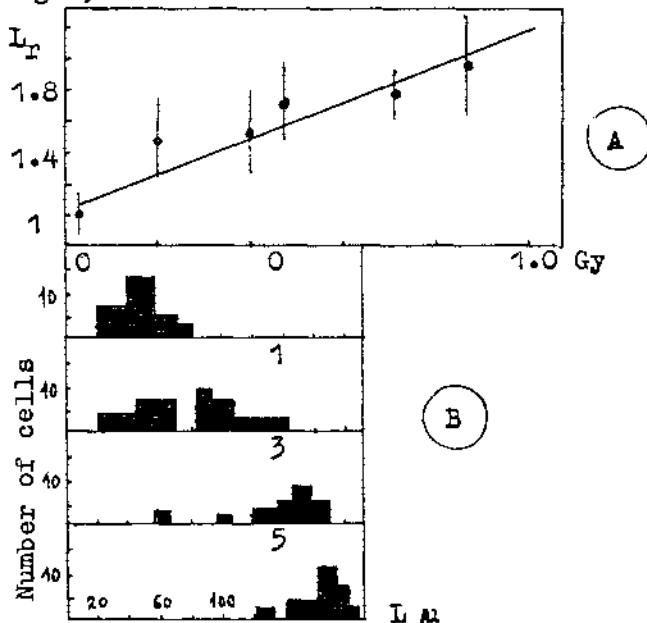

Figure. Radiation dose response for thymocytes exposed to 0-1 Gy (A). Heterogeneity in L_r for cells exposed to 0, 1, 3 and 5 Gy immediately after irradiation (B).

Interestingly, we also observed the clear heterogeneity in DNA damage among the thymocytes even at a dose 1 Gy (Fig.B). The same heterogeneity took place in DNA lesions repair (results not shown). It is noteworthy that this heterogeneity in DNA damage and its repair was not the result of technical considerations.

The next important point is the heterogeneity of control unirradiated thymocytes (Fig.B). Taking into consideration the lysis conditions this heterogeneity is explained in terms of the existence of cells with various amount of spontaneous DNA lesions. It appears that the heterogeneity in preexisting lesions observed in thymocytes within a population determines the heterogeneity in their DNA damage and repair (results not shown).

Lymphocytes that are exposed to low-doses of ionizing radiation become less susceptible to the induction of chromatid aberrations by subsequent high doses of X-rays (radioadaptive response) (7). When lymphocytes were exposed to adapting dose of 1 cGy and incubated with ara-C plus HU for 2h later, the dead cell number decreased (Table). Thus low level doses of irradiation now are seen to have a beneficial effect on the amount of pre-existing DNA lesions probably inducing the repair mechanism that makes the cells less susceptible to the effects of subsequent exposures to gamma-rays.

Table

Death of rat blood lymphocytes after irradiation at 1 cGy (0.5 cGy/min) and subsequent incubation of cells with ara-C and HU for 2h later

Incubation conditions	Dead cells,%	Increase in dead cells,%
Unirradiated	11.9 ± 1.9	16.4
Unirradiated + ara-C + HU	28.3 ± 2.3*	
Incubation for 2h after irradiation	15.2 ± 5.9	7.3
Incubation for 2h after irradiation, then + ara-C + HU	22.1 ± 3.8*	

Lymphocytes were irradiated, pre-incubated for 2h, and further incubated with or without ara-C + HU in the same growth medium for 24h. *P < 0.05; n=5.

Inasmuch the pre-existing DNA lesions plays an essential role in determining the cell susceptibility to the effects of low-dose irradiation we hope that the modified technique of their assessment in single cells will be of value for various needs especially concerning the studies on the Chernobyl accident consequences.

CONCLUSIONS

The modified microelectrophoresis technique permits to detect DNA damage induced by the dose as low as 0.2 Gy and also proved to be suitable for the assessment of the heterogeneity of lymphocytes in pre-existed DNA lesions within a population. Only a small number of cells (up to 100-200) is generally required for the analysis. The heterogeneity pattern is of the potential use in the prediction of the response of human being to the effects of low-doses irradiation and to other toxic pollutants. The resistance of blood lymphocytes to subsequent irradiation is increased after their preliminary irradiation at a dose as low as 1 cGy (adaptive response). It is noteworthy that in the cells previously irradiated at 1 cGy the decrease in the level of pre-existed DNA lesions has been observed.

REFERENCES

1. Filatov, M.V. and Noskin, L.A., 1983, Sensitization of human cells by inhibitors of DNA synthesis following the action of DNA-damaging agents, *Mutation Research*, 110, pp. 393-399.
2. Filippovich, I.V., Sorokina, N.I., Soldatenkov, V.A., Alfeyrova, T.M., Trebenok, Z.A., 1988, Effect of the inducers of cellular differentiation and of ionizing radiation on thymus lymphocytes: chromatin degradation and programmed cell death, *Int. J. Radiat. Biol.*, 53, pp. 617-628.
3. Ostling, O., Johanson, K.J., 1984, Microelectrophoretic study of radiation-induced DNA damages in individual mammalian cells, *Biochem. Biophys. Res. Commun.*, 123, pp. 291-298.
4. Ikushima, T., 1990, Visualization of DNA damage in individual cells, *Annu. Rep. Res. Reactor Inst., Kyoto, Univ.*, 23, pp. 85-90.
5. Olive, P.L., Banath, J.P., Durand, R.E., 1990, Heterogeneity in radiation-induced DNA damage and repair in tumor and normal cells measured using the "comet" assay, *Radiat. Res.*, 122, pp. 86-94.
6. Tronov, V.A., Grinko, E.V., Beritashvili, D.R., Filippovich, I.V., 1991, Microelectrophoresis of DNA from individual intact and gamma-irradiated thymocytes, *Cytology (russ.)*, 33, pp. 94-102.
7. Wolff, Sh., Afzal, V., Wiencke, J.K., Olivieri, G., Michaeli, A., 1988, Human lymphocytes exposed to low doses of ionizing radiations become refractory to high doses of radiation as well as to chemical mutagens that induce double-strand breaks in DNA, *Int. J. Radiat. Biol.*, 53, pp. 39-48.

**ICRP COMMITTEE 1: THE CONTINUING SAGA OF
ESTIMATES OF RISK FOR RADIATION INDUCED CANCER**

Warren K. Sinclair
National Council on Radiation Protection and Measurements
Bethesda, Maryland, U.S.A.

ABSTRACT

The estimates of fatal cancer risk which ICRP used in recommending more restrictive exposure limits for workers and for the public in 1990, were derived from the study of atomic bomb survivors. The many uncertainties in these estimates will be reduced with time as future data accrues in the Japanese study. Recent low dose studies in the Soviet Union, in the U.K. and in the U.S.A. provide tests, within broad limits, of the estimates of risk derived from the atomic bomb survivors. These form part of the continuing saga of cancer risk estimation.

INTRODUCTION

ICRP Committee 1 is responsible for advising the Main Commission of ICRP concerning the biological effects of exposure. In the 1990 recommendations of the ICRP (ICRP, 1991a) these responsibilities included reviewing Chapter 3 on Biological Effects in the main text of Publication 60, preparing the background material on biological effects used by the Commission, *i.e.*, Annex B of ICRP Publication 60 (ICRP, 1991a), and reviewing the selected papers of the Risk Task Group of Committee 1, which supported Annex B (ICRP, 1991b).

ICRP Committee 1 continues surveillance over developments in our knowledge of the biological effects of radiation and sets up working groups and task groups in selected areas as needed. This surveillance embraces all aspects of radiation-induced cancer risk, including the examination of low dose epidemiological studies for possible confirmation of risks from high dose, high dose rate studies.

NOMINAL VALUES OF CANCER RISK

ICRP appraised, for radiation protection purposes (ICRP, 1991a), recent evaluations of cancer risk from all human sources by both the UNSCEAR (1988) and the BEIR V Committee (NAS/NRC, 1990) as well as providing some additional analyses of their own. ICRP concluded that for the general public (*i.e.*, a population of all ages) the nominal risk of fatal cancer following high dose, high dose rate exposure is 10%/Sv, while for an adult (working) population it is about 8%/Sv. ICRP then applied a dose rate effectiveness factor of 2 to these numbers

to obtain the risk for low dose or low dose rate exposure, yielding 5%/Sv and 4%/Sv respectively.

SIGNIFICANT ASPECTS OF NOMINAL VALUES OF CANCER RISK

Certain features of these nominal values need to be emphasized. These include supporting estimates from other studies, projection to lifetime risk, age and sex variations and transfer between populations.

Comparison of cancer risks between different studies

The important study of the survivors of the atomic bombs has limitations, consequently confirmation would be useful. UNSCEAR (1988), (see ICRP, 1991a, Annex B, Table B-4), compared risk estimates for the ankylosing spondylitis in the U.K., and the international cervix series with those for the atomic bomb survivors. The estimates for the ankylosing spondylitis series are lower than for the atomic bomb survivors by a factor of about 2. Given the wide differences in sample, in age, in exposure circumstances, etc. (see Upton, 1991) this difference is small. For the cervical cancer series the agreement is less satisfactory, but the circumstances of exposure are even more different.

Projection of observed results to lifetime risk estimates

To estimate lifetime risk, observations of the survivors in Japan must be projected to the end of the life span of those individuals comprising over 60% of the original population who were alive in 1985. The time course of the increase in induced cancers in a number of sites has followed a multiplicative pattern well so far, consequently, the multiplicative model has been used for projection (UNSCEAR, 1988; Preston & Pierce, 1988). However for some cancer sites the multiplicative model may overestimate the risk, at least slightly. BEIR V (NAS/NRC, 1990) included a term involving time since exposure which enabled the model to be fit separately to the data for individual cancers and thus allow for a small fall-off in some cases. If this trend in the data were to continue, current estimates of lifetime risk based on multiplicative projection would be over projected. The ankylosing spondylitic study already shows a substantial fall off at longer times (Darby et al, 1987).

Recently Kellerer & Barclay (1991) have shown that if the multiplicative projection is based on attained age instead of age at exposure (and the data fit reasonably well), the projected risk is only about a half. Again, this implies over projection for current models.

Age and sex variations

Both UNSCEAR and BEIR V give substantial information on variations in cancer risk with age at exposure and sex, and still more detail, especially for individual organ risks, is available in Land & Sinclair (1991) and in summary form in Sinclair, 1992. The cancer risk is 10 times greater for the 0 to 19y ages than for the 65 to 90y age group. The sex difference is of the order of 10 to 50% depending on age, females having the larger induced cancer risk especially at young ages.

Transfer between populations

When populations other than the Japanese are considered, estimated risks must be transferred to the new population either multiplicatively using the base cancer rates in the new population or additively, independent of the spontaneous rates in the population, as in the NIH model (Rall et al, 1985). Presently it is not known which is the preferred method (Land, 1991; UNSCEAR, 1988; NAS/NRC, 1990) or whether there is a preferred method for all sites. Consequently, in deriving the contributions of the individual organs to the overall detriment, results have been averaged between the two models (Annex B, ICRP, 1991a). The total risks by the two transfer methods also differ somewhat as do results for some other national populations considered in the ICRP evaluation. ICRP averaged results for the two transfer models and for five national populations as well as for age and sex.

DETRIMENT AND ORGAN WEIGHTING FACTORS

ICRP's effective dose is based on the total detriment from a radiation exposure which includes fatal cancer in individual organs and tissues, severe hereditary effects, a weighting of each for length of life lost and a contribution for each organ or tissue from nonfatal cancer. These are listed in Table 1.

The relative contribution of the organs to this total detriment are determined as outlined in Annex B (ICRP, 1991a, Table B-20) and are then rounded to obtain tissue weighting factors. Only four weights are used (Table 2). Uncertainties due to transfer model and to characteristics of national populations have been reduced by averaging and the same weights can be used for all ages, sex and national population.

Table 1 - Nominal probability coefficients
(from ICRP, 1991a)

Exposed Population	Detriment 10^{-2} Sv^{-1}			Total
	Fatal Cancer	Nonfatal Cancer	Severe Hereditary Effects	
Adult workers	4.0	0.8	0.8	5.6
Whole population	5.0	1.0	1.3	7.3

Table 2 - Tissue weighting factors

$w_T =$	0.01	0.05	0.12	0.20					
	Skin Bone surface	Bladder Breast Liver Oesophagus Thyroid "Remainder"	Bone marrow Colon Lung Stomach	Gonads					
$\Sigma w_T =$	0.02	+	0.30	+	0.48	+	0.20	=	1.00

UNCERTAINTIES IN RISK ESTIMATES

The main uncertainties in the estimates of risk for high dose, high dose rate exposure include:

1. uncertainties in the epidemiological data,
2. dosimetric uncertainties, neutron RBE, etc.
3. uncertainty in projection to lifetime
4. uncertainties due to transfer model and
5. variations due to specific age groups or sex.

Some committees have attempted to assign magnitudes to these uncertainties (Rall et al., 1985; NAS/NRC, 1990).

Risk coefficients for low dose or low dose rate exposure are subject to these uncertainties plus those arising from the application of a dose response model or a dose and dose rate effectiveness factor, DDREF. The uncertainty in the DDREF is probably not greater than a factor of two, because the value applied by ICRP is two and the factor that could be assigned is probably not less than one nor more than about four.

FUTURE EXPECTATIONS IN THE STUDY OF THE ATOMIC BOMB SURVIVORS IN JAPAN

The study of the atomic bomb survivors will continue to acquire additional data. By the turn of the century, less than half (44%) of the study population will be surviving, four more cycles of data will have accumulated, time relationships will be better defined and the younger age groups will be further into the ages when cancer is more prevalent. Questions of fall-off (from constant relative risk) with time and overprojection of lifetime risks should be much clearer.

Significant excess of various cancer sites should extend to lower doses, to the group at 0.1 Gy to 0.19 Gy, or even to 0.06 Gy to 0.09 Gy. This will greatly influence the choice of DDREF and if the dose response curve is established at low enough doses perhaps eliminate the need for a choice.

In dosimetry, extension of the DS86 sample from 76,000 to 86,000 is expected in the 1985-89 evaluation. It may subsequently be extended a little further. Small improvements in the dosimetry can be expected and possibly a resolution of the worrisome discrepancy between calculation and measurement with distance for thermal neutrons. Further studies in high-LET radiation biology might provide additional information on neutron RBEs at low doses and permit more precise evaluation of the neutron component.

Incidence data from the tumor registries at Hiroshima and Nagasaki is just becoming available. The greater number of excess tumors, fatal and nonfatal, will improve estimates of the excess and establish better the dose response curve free of complications from treated cases. Incidence data may, in time, take over from mortality, as a superior index of the excess tumors due to radiation induction.

Overall, within not much more than a decade, improved (less uncertain) risk estimates from the atomic bomb survivors should be possible.

LOW DOSE STUDIES

In radiation protection the risk after low doses is paramount and thus direct low dose studies seem to be more relevant than high dose studies. However, most low dose studies suffer from methodological flaws which render the results questionable. Modan, in addressing this question (Modan, 1991), examined studies of fallout, occupational exposure, fetal (medical) exposure, therapeutic experience and natural background studies. Among the principal problems he identified were inadequate dosimetry, limitations on sample size and composition, lack of adequate controls, extraneous effects and sociogeographic confounders. Additional problems include the fact that studies are of too low a statistical power to demonstrate an effect, small numbers tend to increase chance associations and there is often no clear association between radiation dose and effect. Care in interpretation is also necessary if the time relationships involved are not those usually found or the cancers detected in excess are not those usually associated with radiation.

Given all these difficulties few low dose studies have been able to provide quantitative estimates of risk. Nevertheless, some have aspired to describe a range of risk and some of these are becoming of increasing importance as tests of estimates of risk derived from high dose studies.

Recent "quantitative" low dose studies

An early study of U.K. atomic energy workers (Beral et al., 1985) resulted in a broad range of risk estimates which included both the old and the new ICRP estimates. A more recent study of these workers (NRPB, 1991) is more definitive. It obtained a specific risk estimate for leukemia of $0.8 \times 10^{-2} \text{ Sv}^{-1}$, about twice the ICRP value for workers, with broad confidence limits extending to six times the ICRP value. A nonsignificant risk value for all cancers was also derived which had even broader limits.

In the U.S.A. (Gilbert et al., 1989) a study of some nuclear workers did not yield a significant association of leukemia or of all cancer with dose. The estimates ranged from below zero to an upper limit which was about the same value as that derived from the Japanese atomic bomb survivors. An initial report (Matanoski, 1991) on nuclear shipyard workers also lacked a definitive answer. Nuclear workers with exposures above 5 mSv had more leukemia and more hematopoietic cancers than those exposed below 5 mSv. However, both groups were less than for non-nuclear workers. Furthermore, within those above 5 mSv no clear association with dose was found. Further follow-up in this study may yield some more definitive contribution.

Two recent studies from the Soviet Union appear to be of greater intrinsic value, partly because the exposures in early atomic energy work were higher. The first involved workers in the atomic energy program exposed in the period 1947-58. Workers with total exposure above 1 Sv had greater cancer excess than workers below 1 Sv, from which Shlyakhter & Wilson (1991) derived a risk of all cancer expressed as $>3 \times 10^{-2} \text{ Sv}^{-1}$ similar to the $4 \times 10^{-2} \text{ Sv}^{-1}$ for workers of ICRP. In a study of residents in an area of Chelyabinsk (Degteva & Kosenko, 1990), people were exposed via their drinking water from the Techa River which for three years, 1949-52, was used for the disposal of fission products. Modeling the dosimetry appropriately, a risk estimate was derived of about $0.2 \times 10^{-2} \text{ Sv}^{-1}$ for leukemia, half the ICRP value for workers. More information on these studies would be most welcome.

Thus, in spite of the broad ranges only that can be defined, these low dose studies are within about a factor of two of the estimates derived from the atomic bomb survivors.

Possible future low dose studies

From Chernobyl useful data may emerge eventually (perhaps on leukemia only) from evacuated groups or from those in "hotspot" areas of the Ukraine, Byelorussia and Russia.

Also, a comprehensive study has been proposed of all nuclear workers in the U.S.A., possibly to include U.K. and European nuclear workers. A more positive result than any to date could result from such a comprehensive study.

CONCLUSIONS

The study of the atomic bomb survivors will continue to provide more and more data and thus to improve lifetime risk estimates. Some present and future low dose studies may help materially in testing the risk estimates from the atomic bomb survivors.

ICRP Committee 1 will continue to evaluate the situation as new information appears and relate it to radiation protection circumstances.

REFERENCES

- Beral, V., Inskip, H., Fraser, P., Booth, M., Coleman, D. and Rose, G. (1985) "Mortality of employees of the U.K. Atomic Energy Authority 1946-79", *Brit. J. Clin. Res.* 291, 440-447.
- Darby, S.C., Doll, R., Gill, S.K. and Smith, P.G. (1987) "Long term mortality after a single treatment course with x-rays in patients treated for ankylosing spondylitis". *Brit. J. Cancer* 55, 179-190.
- Degteva, M.O. and Kosenko, M.M. (1990) "Analysis of cancer mortality and risk assessment in the population exposed in consequence of disposal of radioactive wastes into the Techa River in southern Urals". Paper

presented to conference with Radiation Effects Research Foundation, Nov. 1990 (RERF, Hiroshima).

- Gilbert, E.S., Fry, S.A., Wiggs, L.D., Voelz, G.L., Cragle, D.L. and Petersen, G.R. (1989) "Analysis of the combined mortality data on workers at Hanford site, Oak Ridge National Laboratory and Rocky Flats Nuclear Weapons Plant", *Radiat. Res.* 120, 19-35.
- ICRP (1991a) International Commission on Radiological Protection. 1990 Recommendations of the International Commission on Radiological Protection, *Annals of the ICRP* 21, 1-2 (Pergamon Press, Oxford).
- ICRP (1991b) International Commission on Radiological Protection. *Risks Associated with Ionizing Radiations*, *Annals of the ICRP* 22, 1-4 (Pergamon Press, Oxford).
- { Kellerer, A.M. and Barclay, D. (1991) "Risk projections under two multiplicative models for cancer mortality among atomic bomb survivors", submitted to *Radiat. Res.*
- { Land, C.E. (1991) "Projection of risk from one population to another". In: *Risk Estimates for Radiation Carcinogenesis*, Proceedings of an International Workshop, K. Renz, Ed., Munstereifel, Germany (Institut für Strahlenschutz, Köln).
- { Land, C.E. and Sinclair, W.K. (1991) "The relative contribution of the different organ sites to the total cancer mortality associated with low dose radiation exposure". In *Annals of the ICRP* 22, 1-4, 31-57 (Pergamon Press, Oxford).
- Matanowski, G.M. (1991) *Health Effects of Low-Level Radiation in Shipyard Workers*. (Johns Hopkins University School of Hygiene and Public Health, Baltimore, Maryland).
- Modan, B. (1991) "Low-dose epidemiological studies: An assessment of methodological problems." In *Annals of the ICRP* 22, 1-4, 58-73 (Pergamon Press, Oxford).
- NAS/NRC (1990) National Academy of Sciences/National Research Council. *Health Effects of Exposure to Low Levels of Ionizing Radiation*, BEIR V Report (National Academy Press, Washington, D.C.).
- NRPB (1991) National Radiological Protection Board. *Mortality and Occupational Exposure to Radiation: First Analysis of the National Registry for Radiation Workers*. in press (NRPB, U.K).
- Preston, D.L. & Pierce, D.A. (1988) "The effect of changes in dosimetry on cancer mortality risk estimates in the atomic bomb survivors", *Radiat. Res.* 114, 437-466.
- Rall, J.E., Beebe, G.W., Hoel, D.G., Jablon, S., Land, C.E., Nygaard, O.F., Upton, A.C., Yalow, R.S. and Zeve, V.H. (1985) *Report of the National Institutes of Health Ad Hoc Working Group to Develop the Radioepidemiological Tables*. (U.S. Government Printing Office, Washington, D.C.).
- Shlyakhter, A. and Wilson, R. (1991) "Radiation doses and cancer". *Nature* 350, 25.
- Sinclair, W.K. (1992) "Radiation induced cancer risk estimation, today and tomorrow" in *Proceedings of the 26th Annual Meeting of the NCRP* (NCRP, Bethesda, Maryland).
- UNSCEAR (1988) United Nations Scientific Committee on the Effects of Atomic Radiation. *Sources, Effects and Risks of Ionizing Radiation*, E.88.IX.7 (United Nations, New York).
- Upton, A.C. (1991) "Risk estimates for carcinogenic effects of radiation". In *Annals of the ICRP* 22, 1-4, 1-30 (Pergamon Press, Oxford).

MORTALITY UNDER AGE 25 AROUND SIX FRENCH NUCLEAR SITES

Catherine Hill and Agnès Laplanche

Institut Gustave Roussy et Institut National de la Santé et de la Recherche Médicale Unité 287, Villejuif, France.

ABSTRACT

Mortality under age 25 between 1968 and 1987 has been studied in the population residing around the six major nuclear sites (two reprocessing plants and four power plants), in operation before 1976 in France. The population under study represents 3 million person-years. A total of 58 leukaemia deaths were observed, similar to the 67 leukaemia deaths expected from national death rates, and to the 62 leukaemia deaths observed in control communes. The risk of leukaemia did not depend on distance to the installation.

INTRODUCTION

In 1983, a British television programme reported an increased incidence of leukaemia in children in the village of Seascale, near the Sellafield nuclear reprocessing plant. Following this report, a working group, commissioned by the British government, concluded that there was an increased incidence of lymphoid leukaemia in children around Sellafield (1), and this result has been confirmed by numerous studies (2-5). Other excesses of leukaemias have been observed around the Dounreay facility, a reprocessing plant located in the North of Scotland (6), in the vicinity of the two nuclear military facilities of Aldermaston and Burghfield (7), and in the vicinity of the Hinkley point nuclear power plant (8).

France derived 75% of its electricity from nuclear energy in 1989, and the first nuclear unit producing electricity started operating industrially in 1962 (9). We have studied the main sites in operation during 1975 or before in order to have a minimum follow-up of 10 years for mortality. Before the study presented here, two studies of mortality around La Hague, French nuclear reprocessing plant had been reported (10,11); their results are summarised elsewhere in the present volume (12).

MATERIALS AND METHODS

Four geographical zones were defined around each installation according to the distance from the installation: <5 km, 5-10 km, 10-13 km, and 13-16 km. For La Hague, the farthest zone bordered the densely populated suburbs of the city of Cherbourg: an extra zone corresponding to a distance of 16-21 km has been considered for this site. France is divided into 36,500 administrative units called 'communes'. The average population of a commune is 1,500, and the average area 15 km². For each site and each zone, the 'exposed'

communes were identified, and for each exposed commune, a 'control' commune was selected as the commune in the same 'Département' having the closest total population figure. This defines, for each site, four (five for La Hague) exposed zones according to the distance to the installation, and the same number of control zones. The average distance between control communes and installation is 53 km (range 16-133 km, s.d. 24 km).

From the Institut National de la Santé et de la Recherche Médicale, we obtained the cause of each death that occurred in the population aged 0-24 between 1968 and 1987, by zone. The underlying cause of each death was coded according to the International Classification of Diseases. Census data by commune were obtained from Institut National de la Statistique et des Etudes Economiques (INSEE), for the three censuses of 1968, 1975, and 1982. The population at risk were estimated from these data.

To test the possible existence of an increase in leukaemia mortality between age 0 and 24 around French nuclear sites, we made two comparisons. First, the observed mortality was compared to the mortality expected from national rates. Second, in an attempt to control for possible systematic differences between death certification procedures in rural, sparsely populated areas and in the country as a whole, the mortality around nuclear sites was compared with the mortality in control communes, matched for total population and large geographical unit (Département).

RESULTS

The table gives the number of leukaemia deaths by type of installation (reprocessing plants versus others) and by distance from installation. The number of leukaemia deaths was 58, which is slightly less than the 66.9 deaths expected from national mortality statistics. Among the other causes considered, two significant differences (both with $p=0.02$, two-sided test) were observed between nuclear sites and national mortality: an excess of Hodgkin's disease, and a deficit of malignant brain tumors. After correction for the multiple tests due to the consideration of several causes of death, these results are no longer significant. No significant differences were observed when comparing the standardised mortality ratios in the exposed and control areas, but these comparisons are less powerful than the comparison of the exposed population to the nation as a whole. There was no effect of sex and age, no difference between reprocessing plants and reactors, and no trend with increasing distance from installation.

Table

Number of person-years, observed and expected number of leukaemia deaths, and standardised mortality ratios (SMR) by type of installation and distance from nuclear installations

Characteristics	Person-years in thousands	Observed	Expected	SMR(%)
Installation				
Reprocessing	1,576	30	36.7	82
Other	1,316	28	30.2	93
Distance in km				
< 5	260	5	6.1	82
5-9.9	982	21	22.7	93
10-12.9	373	4	8.5	47
13-15.9	748	17	17.3	92
16-21	530	11	12.3	90
Total	2,892	58	66.9	87

CONCLUSION AND DISCUSSION

Our study shows no excess leukaemia mortality in the population aged 0-24 residing near French nuclear sites. The power of this study is reasonable: when the reference is the general population, and with an expected number of leukaemias around installations equal to 60, the probability of detecting an increase of 50% is 95% (with a type I error of 5%), and the probability of detecting an increase of 23% is 50% (13). When the reference is a control group of similar size, the probability of detecting an increase of 50% is 80% (13).

Our results confirm Viel and Richardson's study of leukaemia mortality around La Hague (11), which used geographical units with populations seven times larger than in our study.

The excess leukaemia observed around nuclear sites in the United Kingdom was not observed around French nuclear sites. The amount of radioactive effluent discharged might have been higher around Sellafield and Dounreay than around French installations (11). The excess leukaemia observed in the United Kingdom could also be attributed to some characteristic common to Sellafield and Dounreay, but not shared by French installations, for instance a rapid increase of population leading to viral infections (14), or some unknown factor shared by existing and potential nuclear sites in the United Kingdom (15).

References

1. Black D. Investigation of the possible increased incidence of cancer in West Cumbria. London: HMSO 1984.
2. Gardner MJ, Winter PD. Mortality in Cumberland during 1959-

- 78 with reference to cancer in young people around Winscale. Lancet 1984; i: 216-217.
3. Gardner MJ, Hall AJ, Downs S, Terrell JD. Follow up study of children born to mothers resident in Seascale, West Cumbria (birth cohort). BMJ 1987; 295: 822-827.
 4. Gardner MJ, Snee MP, Hall AJ, Powell CA, Downes S, Terrell JD. Results of case-control study of leukaemia and lymphoma among young people near Sellafield nuclear plant in West Cumbria. BMJ 1990; 300: 423-429.
 5. Gardner MJ, Hall AJ, Snee MP, Downes S, Powell CA, Terrell JD. Methods and basic data of case-control study of leukaemia and lymphoma among young people near Sellafield nuclear plant in West Cumbria. BMJ 1990; 300: 429-434.
 6. Heasman MA, Kemp IW, Urquhart JD, Black R. Childhood leukaemia in Northern Scotland. Lancet 1986; i: 266.
 7. Roman E, Beral V, Carpenter L, Watson A, Barton C, Ryder H, Aston DL. Childhood leukaemia in the West Berkshire and Basingstoke and North Hampshire district health authorities in relation to nuclear establishments in the vicinity. BMJ 1987; 294: 597-602.
 8. Ewings PD, Bowie C, Phillips MJ, Johnson SAN. Incidence of leukaemia in young people in the vicinity of Hinkley Point nuclear power station, 1959-1986. BMJ 1989; 299: 289-293.
 9. Memento sur l'énergie. Paris: Commissariat à l'énergie, Paris 1987: 19-21.
 10. Dousset M. Cancer mortality around La Hague nuclear facilities. Health Physics 1989; 56: 875-884.
 11. Viel JF, Richardson ST. Childhood leukaemia around the La Hague nuclear waste reprocessing plant. BMJ 1990; 300: 580-581.
 12. Thomas P. Etudes épidémiologiques relatives au cancer concernant La Hague et sa région. Montréal: IRPA 1992.
 13. Breslow NE, Day NE. The design and analysis of cohort studies. Lyon: IARC 1987.
 14. Kinlen L. Evidence for an infective cause of childhood leukaemia: comparison of a Scottish new town with nuclear reprocessing sites in Britain. Lancet 1988; ii: 1323-1327.
 15. Cook-Mozaffari P, Darby S, Doll R. Cancer near potential sites of nuclear installations. Lancet 1989; ii: 1145-1147.

CHILDHOOD LEUKAEMIA AROUND NUCLEAR FACILITIES IN GREAT BRITAIN

R. Wakeford, K. Binks and A.J.M. Slovak

Health and Safety Directorate, British Nuclear Fuels plc,
Risley, Warrington, Cheshire, UK.

ABSTRACT

The elevated levels of childhood leukaemia incidence around certain nuclear facilities in Great Britain that have been found by epidemiological studies must be viewed with caution. The various inferential problems associated with these studies produce an uncertain interpretation. More research into the causes of childhood leukaemia is required before the distribution of cases is properly understood.

INTRODUCTION

Since the broadcast in 1983 of a television documentary which identified an excess of childhood leukaemia cases in the coastal village of Seascale near the Sellafield nuclear establishment in North-West England, there has been considerable scientific interest in whether the risk of childhood leukaemia is elevated in the vicinity of nuclear installations, and, if so, the reason for this excess risk. Since the Sellafield report, a number of other studies have been published which appear to support the interpretation of a raised risk; but detailed radiological assessments have demonstrated that radiation doses due to discharges are too low to be able to account for the excess cases. This apparent conflict of evidence has led to suggestions that radiation risks have been grossly under-estimated, or that novel leukaemogenic mechanisms are involved. However, before reaching such conclusions, the evidence for a raised risk should be scrutinised more closely.

EPIDEMIOLOGICAL EVIDENCE

The evidence for a discernible excess risk of childhood leukaemia around nuclear installations derives from various epidemiological studies. Epidemiology is predominantly an observational science that relies upon the statistical analysis of health data produced under the uncontrolled conditions of "everyday life". Causal inference based upon non-experimental data is fraught with difficulties, particularly when the health effect of interest is childhood leukaemia which is uncommon (~450 cases per year in Great Britain) and for which the major causes remain unknown (<20% of cases can be accounted for by known causes). Furthermore, childhood leukaemia is a convenient grouping of various types and subtypes of leukaemia, which may have different major causes [1].

It is in the nature of an uncommon disease that, even if the underlying risk is uniform, the distribution of cases will be heterogeneous, in much the same way as winning lottery numbers are not regularly distributed amongst the sequence of ticket numbers. It is possible that the Seascale grouping of cases has arisen purely through the vagaries of chance; but it is also possible that it reflects an excess risk, whatever the cause may be. By itself, the Seascale observation does not allow us to distinguish between these two possibilities, and independent corroborating evidence is required before an excess risk can be inferred. However, reliable supporting evidence is difficult to generate, because the "background" conditions under which further datasets are produced will differ (to a greater or lesser extent) from those experienced by the original cases, and these conditions could modify the risk of childhood leukaemia. In addition, should prior knowledge of the data available for analysis influence the structure of that analysis (eg the choice of location, geographical boundaries or time periods) then severe interpretational problems can result. [2], [3].

We would argue that the influence of prior knowledge has had a major impact upon the development of evidence in this area of epidemiology. The analysis of childhood leukaemia cases around the Dounreay installation in Northern Scotland produced an incidence rate which was ten times the national average when employing geographical and temporal boundaries which were suspiciously tight about the case data; but when more "reasonable" boundaries were used in the analysis, the rate was reduced to twice the national average, and the excess leukaemia incidence did not achieve the margin whereby it could be conventionally regarded as "statistically significant". The reported excess of cases in the vicinity of the Aldermaston and Burghfield establishments (in Berkshire, England) relies heavily upon the decision to include Burghfield (and thereby the town of Reading) in the analysis. Burghfield had featured strongly in an earlier television documentary, and the decision may have been compromised by this knowledge. Other researchers have chosen to exclude this "minor" nuclear weapons facility from their analyses. Similarly, the Hinkley Point (Somerset, England) study was undertaken with the knowledge that leukaemia rates were generally raised in Somerset, and the authors failed to point out that, unlike in previous reports, their result of an excess of cases in young persons was driven by an excess amongst young adults rather than children. However, despite these (and other) shortcomings these three studies have been disconcertingly influential in scientific circles [2], [3].

Cook-Mozaffari et al., have avoided these various selection and reporting biases by including all 15 of the major nuclear installations of England and Wales in their studies [2], [3]. These studies have not been without

weaknesses, being based unavoidably upon mortality data for largish geographical areas, but their strength lies in the comprehensiveness and coherence of analyses which have not been influenced by prior knowledge. In the latest study by this group, an elevated level of leukaemia mortality was found for young people living in areas defined as being associated geographically with nuclear installations: the adjusted mortality rate for these areas was 14% above that for England and Wales [3]. However, the authors do not conclude that this result supports a link between radioactive discharges and excess childhood leukaemia deaths, because, for example, for those areas associated geographically with the installations, rates are higher for populations living further from the installations than the rate for the population living nearest the installations. That the elevated leukaemia mortality rate might have more to do with the "background" risk factors pertaining in those areas geographically associated with nuclear facilities than with factors directly linked with the operations at the facilities is lent support by a subsequent study by Cook-Mozaffari et al. [4] in which the same analyses were performed for areas around potential nuclear power station sites. This study revealed a pattern of cancer mortality which was "strikingly similar" to that for existing sites. Similar studies in other countries (for example, USA and France) have not found any evidence of an excess risk around nuclear installations, which, at present, leaves the UK reports puzzlingly isolated.

Recently, the results of a study by Gardner et al. have indicated that the excess of childhood leukaemia cases near Sellafield may be linked to the occupational doses of radiation received by fathers prior to the conception of their children [5]. This potential explanation is of particular interest because it does not depend upon the somatic doses of radiation received from discharges, but upon occupational exposure of the paternal germ cells. However, it must be appreciated that parental exposure to radiation was only one of a large number of potential explanatory factors examined in this study, and that, under these circumstances, the effects of chance are difficult to quantify. Also, the positive statistical association is based upon four cases and a similarly small number of controls, so that results are not especially robust against minor perturbations in the data. Given the context of this study, a direct causal interpretation of the association cannot be accepted without confirmatory evidence. Presently, such evidence does not exist: a review of earlier studies of low dose preconceptual irradiation has not revealed any reliable associations with childhood cancers, and more recent studies have failed to provide strong support (for example, the excess of childhood leukaemia cases around Dounreay cannot be accounted for by preconceptual work in the nuclear industry), although the results of statistically more powerful studies are not yet available. Perhaps most

importantly, the risk of childhood leukaemia in the children of the Japanese A-bomb survivors is statistically incompatible with that suggested by the Sellafield study, a detectable excess risk being absent in the Japanese children. For these, and other, reasons it is not possible at the present time to be able to interpret the results of Gardner et al. with any confidence. [5].

CONCLUSION

Despite the extensive research that has taken place in response to the Seascale childhood leukaemia cases, a satisfactory explanation of the various reports of raised levels of childhood leukaemia incidence around UK nuclear facilities remains elusive. The interpretation of a number of these reports has been hampered by problems of statistical inference, and the results of further work on the association between childhood leukaemia and paternal preconceptual irradiation must be available before this association is properly understood. It may be that these results will be explicable only when the major causes of childhood leukaemia have been identified, and the results of Kinlen et al., eg [6], are of particular interest in this respect.

REFERENCES

1. Doll, R., 1989, The Epidemiology of Childhood Leukaemia, Journal of the Royal Statistical Society, Series A, 152, 341-351.
2. Wakeford, R., Binks, K. and Wilkie, D., 1989, Childhood Leukaemia and Nuclear Installations, Journal of the Royal Statistical Society, Series A, 152, 61-86.
3. Wakeford, R., Binks, K. and Wilkie, D., 1991, The Test of Hypothesis and Leukaemia Near Nuclear Installations, In: "Statistics in Medicine" (eds F. Dunstan and J. Pickles), Clarendon Press, Oxford, UK.
4. Cook-Mozaffari, P., Darby, S. and Doll, R., 1989, Cancer Near Potential Sites of Nuclear Installations, Lancet, ii, 1145-1147.
5. Wakeford, R., 1991, Editorial, Journal of Radiological Protection, 11, 73-74.
6. Kinlen, L.J., Hudson, C.D. and Stiller, C.A., 1991, Contacts between Adults as Evidence for an Infective Origin of Childhood Leukaemia: an Explanation for the Excess Near Nuclear Establishments in West Berkshire?, British Journal of Cancer, 64, 549-554.

EPIDEMIOLOGY OF LEUKEMIA AMONG NUCLEAR WORKERS:

A QUANTITATIVE ANALYSIS OF RESULTS FROM 8 PUBLISHED STUDIES

Gregg S. Wilkinson (University of Texas Medical Branch)
Nancy A. Dreyer (Epidemiology Resources Inc.)

A quantitative analysis of the published results from epidemiologic studies of 8 nuclear worker cohorts in the U.S. and the U.K. was completed. Only those studies that reported data on the cumulative doses received by individual workers were selected for this analysis. The doses received by workers who were included in these studies were the result of protracted exposures to low LET ionizing radiation. A total of 87 leukemia deaths among white males from a combined total of almost 1.5 million person-years were identified. An overall relative risk of 1.6 for leukemia was calculated after adjustment for age and calendar time for workers with cumulative doses of 10 mSv or greater compared with those with cumulative doses of less than 10 mSv. When workers with doses of 10-50 mSv were compared with those who had cumulative doses of less than 10 mSv, the adjusted relative risk was 1.7. A similar comparison of workers with doses greater than 50 mSv yielded an adjusted relative risk estimate of 1.4. These combined data indicate approximately a 70 percent increased risk for leukemia at doses of 10-50 mSv and a similar (but slightly lower) increased risk at doses above 50 mSv. Empirical evidence from well characterized populations, such as nuclear workers, should be given more weight in estimating the risk of leukemia from protracted exposures to low doses of low LET radiation.

Mailing Address: Gregg S. Wilkinson, Ph.D; Chief, Epidemiology and Biostatistics; Department of Preventive Medicine and Community Health, J-47; University of Texas Medical Branch; Galveston, TX 77550; U.S.A.

Telephone: (409) 761-2335 FAX: (409) 761-5272

ETUDE EPIDEMIOLOGIQUE DE LA MORTALITE D'UN GROUPE DE MINEURS D'URANIUM EN FRANCE

M. Tirmarche, A. Raphalen, F. Allin *
J. Chameaud, P. Bredon **

* CEA/Institut de Protection et de Sécurité Nucléaire/Département de Protection de la Santé de l'Homme et de Dosimétrie, B.P. 6 - 92265 FONTENAY-aux-ROSES Cedex (France)

** SMT MINES - COGEMA

EPIDEMIOLOGICAL STUDY OF THE MORTALITY OF A GROUP OF URANIUM MINERS IN FRANCE

SUMMARY

The exposure of the French uranium miners can be considered as relatively low in comparison to most of the other groups of uranium miners (U.S.A., CANADA, CSSR) that have been published. The mean cumulated exposure of 70 WLM, observed in this French group, is linked to a long duration of underground mining, reflecting a low annual exposure rate. The excess of lung cancer deaths is studied in function of the cumulated exposure and discussed in comparison with the risk factors mentioned by the international committees.

INTRODUCTION

L'enquête épidémiologique sur les mineurs d'uranium en FRANCE est conduite depuis 1984 par l'IPSN (Institut de Protection et de Sécurité Nucléaire) avec la collaboration étroite des Services de Médecine du Travail des Mines et de Surveillance Dosimétrique de la COGEMA.

La mortalité d'un groupe de mineurs d'uranium ayant commencé à travailler au fond entre 1946 et 1972, et exposés au radon et à ses descendants pendant au moins deux ans, est analysée dans le cadre d'une étude de cohorte dont le bilan actuel s'arrête au 31 Décembre 1985. Les mineurs de la cohorte, au nombre de 1785, ont travaillé dans les mines exploitées à cette époque dans le Limousin et en Vendée.

LE SUIVI DOSIMETRIQUE

Le suivi dosimétrique des mineurs d'uranium a été assuré par le même groupe de surveillance radiologique durant la totalité de la période concernée. Les techniques de surveillance ayant cependant évolué avec le temps, il faut distinguer, pour cette étude couvrant les années 1946 à 1985, deux époques essentielles :

- 1) Depuis 1956 il existe, pour chaque année, des enregistrements de l'exposition individuelle au radon et à ses descendants ; 1956 coïncide avec la mise en place de mesures de radioprotection importantes qui ont fait baisser le niveau d'exposition au radon d'un facteur 5 à 10. La cohorte de mineurs embauchés depuis 1956

peut donc être suivie en se basant sur une dosimétrie individuelle ; ceci est un avantage certain comparativement aux études américaines et canadiennes, où la dosimétrie a dû être évaluée rétrospectivement.

- 2) L'estimation a posteriori de l'exposition individuelle a été nécessaire pour la période antérieure 1946-1955. Un niveau de concentration en radon et une valeur du facteur d'équilibre entre le radon et ses descendants ont été reconstitués par des experts.

L'historique dosimétrique de chaque mineur est donc retracé depuis sa date de début de travail au fond jusqu'à sa date de départ de la mine. La figure 1 indique la distribution de l'exposition individuelle au radon, au cours des années, exprimée en Working Level Months (le WLM est le produit d'une concentration volumique d'énergie par une durée. La concentration volumique d'énergie est le Working Level, soit $1,3 \cdot 10^8$ Mev par m^3 d'air dû au rayonnement alpha émis par le gaz radon et ses descendants présents dans l'air. La durée est le mois, soit 170 heures de travail).

Comparativement aux études menées aux U.S.A. (1, 2), au CANADA (3, 4), ou en TCHÉCOSLOVAQUIE (5) sur des groupes de mineurs d'uranium, l'étude française se caractérise par des expositions annuelles relativement faibles, aboutissant à une exposition cumulée individuelle qui vaut en moyenne 70 WLM (tableau 1). Il en ressort que cette cohorte permet d'étudier le risque de cancer pour une exposition cumulée faible obtenue sur une longue durée d'exposition longue, la durée moyenne d'exposition au radon étant de 14,5 ans.

LA RECHERCHE DES CAUSES DE DECES

En FRANCE, toute étude épidémiologique de cohorte, visant à étudier les effets à long terme et notamment le risque de décès par cancer, se heurte au problème du suivi des mineurs au-delà de leur départ en retraite à l'âge de 55 ans. C'est le Service de Médecine du Travail des Mines de la COGEMA qui est responsable de la recherche des causes de décès. En effet, à l'inverse des pays anglo-saxons et scandinaves, la FRANCE n'a pas de fichiers nominatifs nationaux des causes de décès ; cette recherche se fait donc au niveau local, grâce à la collaboration des hôpitaux et de la famille, et la cause de décès ainsi recueillie est vérifiée soigneusement.

RESULTATS

La mortalité par cancer de ces mineurs est comparée à celle de la population masculine nationale de même structure d'âge, par la méthode de standardisation indirecte. Le nombre de décès observé est comparé au nombre attendu à l'aide du rapport de mortalité standardisé (SMR). Le nombre de personnes-années est calculé jusqu'à la date de décès, et, pour ceux qui sont encore vivants, jusqu'au point actuel de fin de suivi, soit le 31 Décembre 1985. Les 1785 mineurs précités totalisent 44 995 personnes-années. Le tableau 2 indique les décès par cancer significativement en excès. La mortalité par cancer du poumon est en excès sur la totalité de la cohorte. Quand l'analyse est limitée au groupe faiblement exposé, c'est-à-dire ceux embauchés depuis 1956, l'excès de cancers du poumon reste statistiquement significatif. Pour les décès par

cancer du larynx, l'excès est principalement dû aux mineurs ayant travaillé pendant la période 1946-1955. Un excès par cancers du cerveau est observé sur le groupe faiblement exposé. Il est à noter qu'aucun excès de leucémies n'est observé.

Les cancers du poumon et du larynx sont fortement liés à la consommation tabagique et, dans un moindre degré, au niveau socio-économique. Pour qu'un facteur tel le radon puisse être incriminé, l'augmentation du risque de cancer doit être fonction de l'exposition cumulée. En admettant pour le cancer du poumon une relation linéaire entre le rapport de mortalité standardisé et l'exposition cumulée, il est possible de démontrer que la pente de la droite est proche de 0,6 % par WLM. Cette valeur, plus faible que celle de la plupart des autres études, se situe dans l'intervalle (0,5 à 1,5 % par WLM) donné dans la CIPR 50 (6).

PERSPECTIVES

Il est prévu de prolonger la surveillance de cette cohorte pour deux raisons principales ; d'une part, la cohorte est encore trop jeune pour que la totalité du risque de cancer du poumon se soit exprimée. D'autre part, la faible exposition annuelle observée présentement devrait permettre de mieux préciser le risque associé aux faibles expositions. L'enregistrement systématique de la dosimétrie est un élément favorable pour le suivi.

Parallèlement une collaboration au niveau international s'est établie pour analyser de façon conjointe les résultats d'une dizaine de cohortes de mineurs, avec l'objectif de mieux quantifier la relation entre l'exposition et l'effet.

REFERENCES

1. Hornung, R.W. and Meinhardt, T.J., 1987. Quantitative Risk Assessment of Lung Cancer in U.S. Uranium Miners, *Health Physics*, 52, pp.417-430.
2. Samet, J.M., Pathak, D.R., et al. Lung Cancer Mortality and Exposure to Progeny in a Cohort of New Mexico Underground U Miners, To be published in *Health Physics*.
3. Howe, G.R., Nair, R.C., et al., 1987. Lung Cancer Mortality (1950-80) in Relation to Radon Daughter Exposure in a Cohort of Workers at the Eldorado Port Radium Uranium Mine : Possible Modification of Risk by Exposure Rate, *Journal of the National Cancer Institute*, 79, pp. 1255-1260.
4. Muller, J., Wheeler, W.C., et al., 1984. Study of Mortality of Ontario Miners, In *Proceedings of the International Conference on Occupational Radiation Safety in Mining*, 1, pp.335-343. Canadian Nuclear Association, Toronto, Canada B. Stocker, editor.
5. Sevc, J., Kung, E., et al., 1988. Cancer in Man After Exposure to Rn Daughters, *Health Physics*, 54, pp. 27-46.
6. ICRP 50, 1987. Lung Cancer Risk from Indoor Exposures to Radon Daughters, Vol. 17, n° 1, Pergamon Press.

CARACTERISTIQUES DE LA DISTRIBUTION
DE L'EXPOSITION INDIVIDUELLE
PAR ANNEE D'ETUDE (WLM)

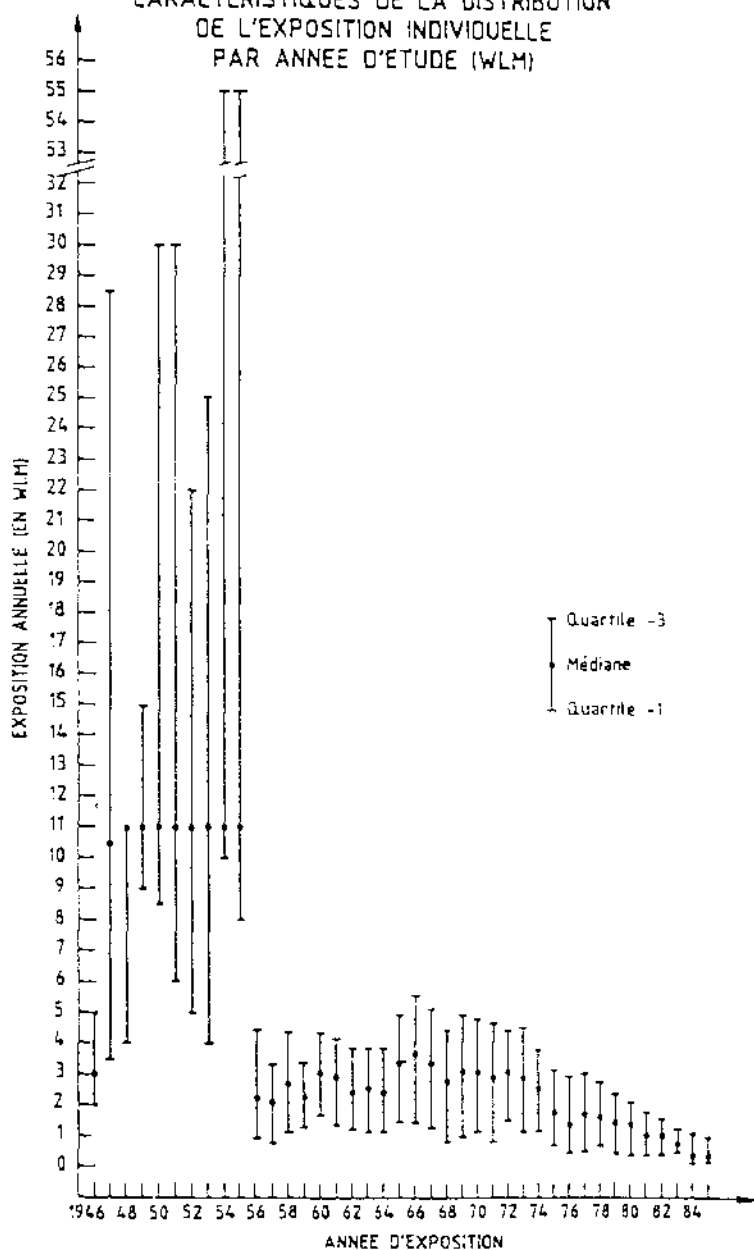

Figure 1

TYPE D'ETUDE	EXPOSITION CUMULEE EN WLM
Colorado [1]	430 (médiane) 831 (moyenne)
New Mexico [2]	35 (médiane) 111 (moyenne)
Ontario [4]	60 ± 25 (moyenne + écart type)
Eldorado (Port Radium) [3]	183 (moyenne)
Tchécoslovaquie [5]	226 (moyenne)
France	70 (moyenne)

Tableau 1

MORTALITE	Nb. OBS.	SMR	SIGNIF.STATIST.
Toutes causes	352	1,07	n.s.
Tous cancers	118	1,26	p = 0,008
Cancer pulmonaire	45	2,13	p = < 0,0001
Cancer du larynx	17	2,35	p = 0,001
Cancer du cerveau	7	1,89	p = 0,08

1785 sujets

Durée moyenne de suivi : 25 ans
 Age moyen des vivants : 57 ans
 Nombre moyen d'années au fond : 14,5

Tableau 2

BILAN DE LA MORTALITE PAR CANCER DES TRAVAILLEURS DU CEA ET DE LA COGEMA DE 1969 A 1986

M. Tirmarche*, A. Raphalen*, F. Allin*, P. Le Guen**

* CEA/Institut de Protection et de Sûreté Nucléaire/Département de Protection de la Santé de l'Homme et de Dosimétrie, B.P. 6 - 92265 FONTENAY-aux-ROSES Cedex (France)

** Conseiller Médical CEA

CANCER MORTALITY OF NUCLEAR WORKERS OF CEA AND COGEMA FROM 1969 TO 1986

SUMMARY

Cancer mortality of the nuclear workers of CEA and COGEMA has been collected by the occupational health services of both firms from 1969 to 1986. The data are related only to the workers who died when in activity. Only very few workers left CEA and COGEMA before retirement ; so we consider this mortality survey as describing correctly the cancer mortality for the age groups less than 60-65 years old. Compared to the national mortality of same sex, age and calendar period, by the method of indirect standardization, the only excess observed was in the female population, linked to breast cancer mortality. The male population demonstrated a high healthy worker effect, even for cancer mortality. This study has now to be completed by an typical epidemiological cohort study in order to test cancer mortality after retirement and to discuss a possible relation with occupational exposure.

INTRODUCTION

La mortalité par cancer des agents du Groupe CEA (CEA civil et militaire ainsi que de COGEMA, à l'exception des mineurs d'uranium) a été recueillie de façon systématique par les différents services de médecine du travail. Elle est enregistrée par cause de décès par le Conseiller Médical du Groupe CEA. Le but de ce travail est de surveiller, de façon continue, au niveau de la médecine du travail, la mortalité de ce groupe de travailleurs pour la comparer à celle de la population nationale.

Le bilan réalisé sur la période 1969 à 1986 ne peut être considéré comme une étude épidémiologique dite de cohorte, car le suivi des travailleurs est limité aux seuls agents en activité et ne concerne donc qu'une population âgée de moins de 60 à 65 ans.

METHODOLOGIE

Les causes de décès par cancer des travailleurs sont transmises de façon anonyme par la médecine du travail, chaque individu étant caractérisé par sa date de naissance, sa date

d'embauche et sa date de décès. Pour le bilan actuel, la date de fin d'étude est le 31 Décembre 1986. Pour chaque cause de cancer retenue, le nombre de décès observé (O) est comparé au nombre attendu (A) qui a été obtenu en appliquant à la structure d'âge de la population active du CEA et de COGEMA, les tsux de mortalité nationaux spécifiques, par sexe et par année. Les résultats apparaissent dans les tableaux 1, 2 et 3 sous forme de rapport de mortalité standardisé O/A (ou SMR). Si le SMR est différent de 1, un test statistique, basé sur l'hypothèse que O suit une loi de Poisson de paramètre A, permet de déterminer si l'excès ou le déficit observé est significatif.

RESULTATS

La mortalité toutes causes est significativement inférieure à celle de la population nationale, aussi bien pour les travailleurs masculins que féminins.

La mortalité par cancer des agents CEA et COGEMA indiquée dans le tableau 1 pour les hommes, et dans le tableau 2 pour les femmes, est aussi significativement inférieure, si la période globale 1969-1986 est considérée. Sur le groupe féminin, un excès de mortalité par cancer est observé sur les six dernières années ; il s'explique par un nombre élevé de décès par cancer du sein : 19 observés pour 7,45 attendus (tableau 3).

DISCUSSION

Dans le groupe masculin, l'étude de la mortalité par cancer considérée globalement, ou selon les différentes causes, ne montre pas d'excès. Il est vrai que les décès par cancer apparaissent majoritairement au-delà de 60 ans. Cependant, vu le type de population suivie, un excès de décès par leucémies aurait pu être attendu [1]. Sur la période de l'étude, 3 décès par leucémies ont été observés pour 2,74 attendus et le SMR de 1,09 est non significatif. Il existe également un net déficit des décès par cancer bronchique ; ceci indique que le groupe étudié est peu exposé à des facteurs cancérigènes tels que le tabac. La mortalité toutes causes, également en déficit, reflète le fameux "healthy worker effect" des groupes de travailleurs ayant ce type d'activités professionnelles [2].

L'excès de décès par cancer du sein, observé dans le groupe féminin peut refléter la différence de niveau socio-économique entre ce groupe et la population féminine nationale. L'exposition professionnelle ne semble pas intervenir : une seule femme, sur les 19 décédées durant la période 1981-1986, a cumulé plus de 10 mSv. La possibilité d'une étude cas-témoin est actuellement envisagée afin de tenir compte des différents facteurs intervenant dans le risque de cancer du sein (nombre de grossesse, âge au premier enfant, etc...).

Parallèlement il est envisagé de réaliser, en collaboration avec le Centre International de Recherche sur le Cancer à LYON, une vaste étude de cohorte des travailleurs du nucléaire en France.

REFERENCES

1. Tirmarche, M., 1987. Etudes du risque cancérigène chez les travailleurs exposés aux rayonnements ionisants. Revue critique des études épidémiologiques actuelles, Proceedings of an NEA Workshop on Epidemiology and Radiation Protection, Paris, 13-15 Octobre 1987, pp. 53-66, Nuclear Energy Agency OCDE.
2. Carpenter, L., Beral, V., Fraser, P., Booth, M., 1990. Health related selection and death rates in the United Kingdom Atomic Energy Authority workforce, Brit. J. of Ind. Medicine, 47, pp. 248-258.

MORTALITE PAR DECES TOUTES CAUSES (CIM 8 : 1 - 999)

Population masculine (1969 - 1986)

Année	Nombre observé	Nombre attendu	SMR	p
1969 à 1980	633	1 350	0,47	
1981 à 1986	376	731,1	0,51	
TOTAL	1 009	2 082	0,48	

La mortalité toutes causes est largement inférieure à celle de la population masculine nationale ($p < 0,001$).

Population féminine (1969 - 1986)

Année	Nombre observé	Nombre attendu	SMR	p
1969 à 1980	71	107,0	0,66	
1981 à 1986	67	63,94	1,05	0,37
TOTAL	138	171,0	0,81	

La mortalité toutes causes est significativement inférieure à celle de la population féminine nationale ($p = 0,005$).

Tableau 1

MORTALITE PAR CANCER TOUTES LOCALISATIONS (CIM 8 : 140-207)

Population masculine (1969 - 1986)

Année	Nombre observé	Nombre attendu	SMR	p
1969 à 1980	213	351,9	0,61	
1981 à 1986	142	237,5	0,60	
TOTAL	355	589,3	0,60	

Pour toute la période considérée, la mortalité par cancer de la population masculine du CEA et de la COGEMA est inférieure à celle de la population nationale (différence statistiquement significative : $p < 0,001$).

Population féminine (1969 - 1986)

Année	Nombre observé	Nombre attendu	SMR	p
1969 à 1980	32	35,21	0,91	
1981 à 1986	41	24,47	1,68	0,001
TOTAL	73	59,68	1,22	0,05

L'excès de mortalité par cancer dépend de la période 1981 - 1986. Il s'explique essentiellement par une augmentation significative de la mortalité par cancer du sein.

Tableau 2

MORTALITE PAR CANCER DU SEIN (CIM 8 : 174)

Population féminine (1969 - 1986)

Année	Nombre observé	Nombre attendu	SMR	p
1969 à 1980	8	9,56	0,84	
1981 à 1986	19	7,45	2,55	< 0,001
TOTAL	27	17,01	1,59	0,02

Un net excès de mortalité par cancer du sein est observé sur la population féminine en activité entre 1981 - 1986.

Tableau 3

GENDER SPECIFIC RISKS FOR FEMALE IONIZING RADIATION WORKERS

R. McFadden

Radiation Protection Service
Ontario Ministry of Labour
Toronto, Ontario, Canada

ABSTRACT

Following exposure to ionizing radiation, certain neoplastic diseases are expressed significantly more frequently in females than in males. Radiation associated ovarian cancer and the differential disease rates for thyroid cancer, breast cancer and other carcinomas lead to higher gender specific risks for female radiation workers when compared to males. This has implications for the calculation of the effective dose in both genders and for practical radiation safety procedures, especially for certain organs such as the breast and thyroid. The radiation associated fatal cancer rate in females is 60 % higher than in males.

INTRODUCTION

Tissue Weighting Factors recommended by the International Commission on Radiological Protection (ICRP) (1) are based on estimations of the adverse effects of radiation on the health of those exposed. In these calculations, which use the ICRP concept of Detriment, the gender averaged incidence of fatal cancer is aggregated with a weighted incidence of non-fatal cancer and genetic effects. Calculated below are Gender Specific Tissue Weighting Factors based on the incidence of cancer and genetic effects in both sexes. These TWF explicitly delineate the adverse effects of radiation on males and on females.

The ICRP TWF (1) are listed in their Table B-20. The development of the TWF is shown in Chapter 5 and particularly pp 120-136. The ICRP chooses to use several important averages in the development of TWF: sex, par. B99; age, par. B100; and national population par. B101-B105.

Implicit in the ICRP TWF calculation is the definition of the Detriment, a measure of the possible harm to the person exposed, par. B115 and par. B117-119. The probabilities of fatal cancer, Table B-17, on which the detriment is based, implicitly contain gender averaging. The relative length of life lost, Table B-18 and fraction of fatal cancers, Table B-19, also result from these averaging processes.

CALCULATION

An alternate approach is to carry out a calculation of a set of TWF for each gender. Gender averaging is the averaging process most at question in the ICRP approach to the calculation of TWF. There are incontrovertible differences between the two genders in their responses to ionizing radiation. At least some of these differences are biologically based:

FEMALE	MALE
ovaries	no organ
breast	female to male fatal cancer rate in range 107/1 to 150/1
thyroid	female to male fatal cancer rate 3 to 1
colon	female to male fatal cancer rate 3 to 1
oesophagus	female to male fatal cancer rate 2.4 to 1

The ICRP ovarian cancer rate results from an average over both genders. Because this organ is not present in the male, the ICRP rate must be multiplied by a factor of two to account for gender averaging and to obtain the gender specific female rate. $f = 0.20 \times (10^{-2}) / (Sv)$. The ICRP breast cancer rate also results from an average over gender. The algebraic expression to obtain the female rate is given by the following equations where: F = gender averaged fatal cancer rate; f = female fatal cancer rate; m = male fatal cancer rate; and R = f/m.

$$\text{Eq. 1} \quad f = (2FR)/(1+R)$$

$$\text{Eq. 2} \quad m = (2F)/(1+R)$$

The gender ratio R = 107 to 150 for breast cancer in the U.S. population (3) (4). This leads to a fatal female cancer rate which almost twice the ICRP rate. $f = 0.396 \times (10^{-2}) / (Sv)$.

The BEIR V preferred model for breast cancer (2) also shows an age structure of significance for the working population of females, after accounting for gender averaging. First, for females under 20 years, breast cancer is expressed 4 times more frequently than the adult female between the ages of 20 and 40 years at time of exposure to radiation. Second, for females over 40 years, breast cancer is expressed at 40 % of the rate of the adult female between the ages of 20 and 40 years at exposure.

ICRP data (1) Table B-12 and (4) may be combined to obtain an estimate of the relative probability of fatal cancer by gender and organ. These estimates of R are used with the ICRP 60 gender averaged fatal cancer incidence rates of Table B-20 to obtain gender specific fatal cancer incidence rates. These appear in the recalculations of the Gender Specific TWF below.

ICRP fatal fraction data are shown in Table B-19. However, for some organs the fatal fraction, k , differs with gender. Again choosing to use the data of (4) and 10-year cancer survival rate data, (4) Table 1 and Table 2, it is possible to estimate the fatal fraction by organ and gender. For all organs females have lower fatal fractions than do males. For example, the fatal fractions (male, female) are: Breast (0.63, 0.53), Thyroid (0.25, 0.17), and Remaining (0.77, 0.58). These data imply that females have somewhat higher cancer survival rates, at least based on the definition of 10-year survival. For expected life lost, ICRP (1) Table B-18 and B-20 data are used.

Using these data and equations a set of Gender Specific TWF can be recalculated. The calculations are shown in a format which permits simple comparison with ICRP 60 Table B-20. Results are shown in Tables I and II below. A column is added to the calculations. This column, labelled "relative contribution male" or "relative contribution female" uses the appropriate gender detriment as a basis for illustrating the sensitivity of the organs within that gender.

TABLE I Tissue Weighting Factors - Female

	Prob. fatal cancer F (per 10+4 female/Sv)	Severe genetic effects (per 10+4 Sv)	Relative Length of life lost 1/la	Relative non-fatal contrib. (2-k)	Product F(1/la)(2) (per 10+4 female/Sv)	Rel. contrib. to ICRP female	Rel. contrib. female
Bladder	20.02		0.65	1.40	18.22	0.02	0.03
BoneMar	38.93		2.06	1.14	91.43	0.11	0.13
Bone Surf	5.00		1.00	1.43	7.15	0.01	0.01
Breast	39.74		1.21	1.47	70.68	0.08	0.10
Colon	128.40		0.83	1.28	136.41	0.16	0.19
Liver	15.00		1.00	1.02	15.30	0.02	0.02
Lung	102.16		0.90	1.09	100.22	0.12	0.14
Oesph	42.34		0.77	1.03	33.58	0.04	0.05
Ovary	20.00		1.12	1.30	29.12	0.03	0.04
Skin	2.00		1.00	2.00	4.00	0.00	0.01
Stmch	127.86		0.83	1.08	114.61	0.13	0.16
Thyroid	12.00		1.00	1.83	21.96	0.03	0.03
Remain	63.77		0.91	1.42	82.40	0.10	0.11
Gonads		100	1.33		133.00	0.15	0.18
Total	617.22				858.08	1.00	1.18
					ICRP 60 Total Table 8-20		725.3

Prob. fatal cancer F (per 10 ⁴ males/Sv)	TABLE II		Tissue Weighting Factors - Male			
	Severe genetic effects 10 ⁴	Relative Length of life lost 1/1a	Relative non-fatal contrib (2-k)	Product F(1/1a) (2-k) (per 10 ⁴ males/Sv)	Rel contrib. males	Rel normalize to ICRP males
Bladder	39.98	0.65	1.35	35.09	0.06	0.05
Bone Mar	61.07	2.06	1.13	142.15	0.24	0.20
Bone Surf	5.00	1.00	1.38	6.90	0.01	0.01
Breast	0.26	1.21	1.37	0.44	0.00	0.00
Colon	41.60	0.83	1.23	42.47	0.07	0.06
Liver	15.00	1.00	1.01	15.15	0.03	0.02
Lung	67.84	0.90	1.05	64.11	0.11	0.09
Oesph	17.66	0.77	1.02	13.87	0.02	0.02
Ovary	0.00			0.00	0.00	0.00
Skin	2.00	1.00	2.00	4.00	0.01	0.01
Stmch	92.14	0.83	1.06	81.06	0.14	0.11
Thyroid	4.00	1.00	1.75	7.00	0.01	0.01
Remain	36.23	0.91	1.23	40.55	0.07	0.06
Gonads	100	1.33		133.00	0.23	0.18
Total	617.22			585.78	1.00	0.81

CONCLUSION

Gender Specific TWF make explicit that in the male the organs are equal or less in sensitivity than the ICRP reference and females are equal or greater than the ICRP reference. For the evaluation of population exposures of equal numbers of both sexes, the ICRP reference may be appropriate. However, in evaluating practical safety practices where females of various ages may be exposed to ionizing radiation, it is necessary to consider gender specific TWF. Applications may, for example, emphasise the female breast and thyroid. Finally, the ratios of fatal cancer estimates indicate that females are at a 60 % greater risk of fatal cancer than are males for cancers associated with exposure to radiation.

REFERENCES

- (1) International Commission on Radiological Protection, Annals of the ICRP, ICRP Publication 60, 1990 Recommendations of the International Commission on Radiological Protection, Pergamon Press 1991
- (2) National Academy of Science, Committee on the Biological Effects of Ionizing Radiation, Health Effects of Exposure to Low Levels of Ionizing Radiation, BEIR V, National Academy Press, Washington 1990
- (3) Mettler, F.A. and Moseley, R.D., Medical Effects of Ionizing Radiation, Grune & Stratton Inc. 1985 Orlando Fla.
- (4) Ca-A Cancer Journal for Clinicians, Ca 39: 3-39, 1989; as quoted in: Cancer Statistics, American Cancer Society 1989

ETUDES EPIDEMIOLOGIQUES RELATIVES AUX CANCERS
CONCERNANT LA HAGUE ET SA REGION

P. THOMAS, Chef du Service Médical de l'Etablissement
COGEMA DE LA HAGUE

The separate investigations have been made of cancer-related deaths among the population living in the vicinity of the La Hague reprocessing plant. The results of these investigations are in agreement. They show, especially as far as leukemia is concerned, that the number of deaths recorded is no higher than the number of deaths forecast.

A la suite de la publication des premières études britanniques faisant état d'un excès de décès par leucémies dans les populations voisines des installations nucléaires de SELLAFIELD et DOUNREAY, la presse française a évoqué à plusieurs reprises la possibilité d'une augmentation des cancers en général et des leucémies en particulier dans l'environnement de l'usine de retraitement des combustibles usés de La Hague. Si, compte tenu des niveaux d'activité des rejets, une telle possibilité paraissait extrêmement réduite, elle justifiait néanmoins la réalisation d'études épidémiologiques.

L'usine de retraitement de La Hague est située dans le Nord-Ouest de la France, à l'extrémité de la péninsule du Cotentin. Cette usine, construite en 1966, a retraité depuis 1968 plus de 8400 tonnes de combustibles usés. Par ailleurs, sont implantés dans la même région une centrale nucléaire de 2 x 1300 MWE et un chantier naval construisant les sous-marins nucléaires français.

Les études épidémiologiques relatives à la mortalité par cancer dans la région de La Hague sont au nombre de trois :

1° - Etude de M. DOUSSET : "Mortalité par cancer autour des installations nucléaires de La Hague" (1).

Cette étude concerne la mortalité par cancer dans le canton de Beaumont-Hague (la France est divisée en 95 départements, eux-mêmes divisés en "arrondissements" ; ces derniers étant subdivisés en "cantons". Le "canton" peut-être comparé au "district" britannique). Le canton de Beaumont-Hague, sur le territoire duquel est implantée l'usine de retraitement compte 19 communes ; la commune de Beaumont-Hague est le chef lieu de ce canton dont la population, lors du recensement de 1982, s'élevait à 7408 habitants.

Les premiers rejets de l'usine ont eu lieu en 1968. L'auteur a considéré que le temps de latence minimum pour les leucémies était de 2 ans, et de 7 ans pour les autres cancers (valeurs généralement adoptées par les radiopathologistes). Les décès par leucémies ont été étudiés de 1970 à 1982 et, pour les autres cancers, de 1975 à 1982.

La mise à jour publiée en 1990 a permis d'étendre l'étude jusqu'en 1985.

La population de référence à partir de laquelle a été établi le nombre de cas attendus est la population du département de la Manche, auquel appartient le canton de Beaumont-Hague.

Le chiffre de population et la distribution par groupe d'âge sont déterminés tous les 7 ans par un recensement national. Les recensements pris en compte sont ceux de 1968, 1975 et 1982.

L'étude de M. DOUSSET précise par année, par sexe et par tranche d'âges les décès dus à l'ensemble des cancers sauf les leucémies, les décès dus aux cancers du sein, aux cancers de la prostate, aux myélomes multiples, aux cancers de la trachée, des bronches et du poumon et enfin aux décès dus aux leucémies.

Le tableau suivant résume les résultats de l'enquête pour la période 1968-1985 : on constate qu'il n'y a aucun excès de décès par leucémies parmi les personnes de moins de 25 ans et qu'il n'existe aucune différence significative entre la mortalité par cancer dans le canton de Beaumont-Hague et celle du département de la Manche.

NOMBRE DE CAS DE DECES ATTENDUS ET OBSERVES DANS			
LE CANTON DE BEAUMONT-HAGUE			
NATURE DE L'AFFECTION	SEXE	ATTENDUS	OBSERVES
Toutes affections malignes à l'exception de la leucémie..	les deux	110,8	111
Appareil digestif	masculin	31,1	32
(CIM 150-159).....	féminin	16,7	16
Poumon (CIM 162).....	masculin	10,3	9
	féminin	0,12	0
Sein (CIM 174).....	féminin	6,3	6
Utérus et ovaires			
(CIM 179-180, 182, 187).....	féminin	5	3
Prostate (CIM 185).....	masculin	7,3	8*
Vessie (CIM 188).....	les deux	2,3	3*
Leucémie (CIM 204-208)			
Tous âges.....	les deux	6,6	6
Moins de 25 ans.....	les deux	(0,95)	(1)
Autres localisations.....	les deux	31,7	34*

* non significatif

2° - Etude de J.F. VIEL et S. RICHARDSON : "Leucémie de l'enfant et usine de retraitement" (2).

Cette étude portant sur les périodes 1968-1978 et 1978-1986 concerne la population habitant à l'intérieur d'un périmètre déterminé autour de l'usine. La surface ainsi définie a été divisée en 3 zones délimitées par 3 cercles concentriques de 10, 20 et 35 Km de rayon. La population de référence est la population du département de la Manche. Trois tranches d'âge ont été étudiées : 0-4 ans, 5-15 ans et 15-24 ans.

Les résultats de cette enquête figurent dans le tableau suivant : ils confirment les résultats de l'enquête de M. DOUSSET.

: Période d'étude. :	:	:	: Rapport Stan-
: Distance de :	: Décès :	: Décès :	: dardisé* de :
: l'usine :	: observés :	: attendus :	: mortalité(%) :
: 0-4 ans :	:	:	:
: <u>1968-78</u> :	:	:	:
: <10 km :	: 0 :	: 0,143 :	: 0 :
: 10-<20 km :	: 2 :	: 1,831 :	: 109 :
: 20-<35 km :	: 0 :	: 1,038 :	: 0 :
: <u>1979-86</u> :	:	:	:
: <10 km :	: 0 :	: 0,096 :	: 0 :
: 10-<20 km :	: 2 :	: 0,986 :	: 203 :
: 20-<35 km :	: 1 :	: 0,669 :	: 149 :
:	:	:	:
: 5-14 ans :	:	:	:
: <u>1968-78</u> :	:	:	:
: <10 km :	: 0 :	: 0,340 :	: 0 :
: 10-<20 km :	: 0 :	: 3,935 :	: 0 :
: 20-<35 km :	: 3 :	: 2,697 :	: 111 :
: <u>1979-86</u> :	:	:	:
: <10 km :	: 0 :	: 0,220 :	: 0 :
: 10-<20 km :	: 2 :	: 2,126 :	: 94 :
: 20-<35 km :	: 2 :	: 1,617 :	: 123 :
:	:	:	:
: 15-24 ans :	:	:	:
: <u>1968-78</u> :	:	:	:
: <10 km :	: 0 :	: 0,136 :	: 0 :
: 10-<20 km :	: 5 :	: 2,002 :	: 250 :
: 20-<35 km :	: 0 :	: 1,199 :	: 0 :
: <u>1979-86</u> :	:	:	:
: <10 km :	: 1 :	: 0,214 :	: 467 :
: 10-<20 km :	: 1 :	: 2,579 :	: 38 :
: 20-<35 km :	: 2 :	: 1,746 :	: 115 :
:	:	:	:

Il faut noter que les taux standardisés de mortalité pour l'ensemble des classes d'âges, les périodes et les zones est de 0,89 (nombre de cas observés : 21 - nombre de cas attendus : 23,6).

* Rapport standardisé de mortalité (Standardized Mortality Ratio) = nombre de décès observés/nombre de décès attendus.

3° - Enquête de C. HILL et A. LAPLANCHE : "Etude sur la mortalité par cancer autour des centres nucléaires français (3).

Cette étude fait l'objet d'une communication particulière dans le cadre de ce Congrès. Elle sera donc, ici, brièvement résumée.

Dans ce rapport, l'étude des populations de La Hague est incluse dans une étude plus vaste englobant les populations voisines de 5 autres établissements industriels nucléaires (période étudiée : 1968-1987). Les résultats confirment les résultats des 2 études précédentes : il n'existe aucune différence significative entre le nombre des décès constatés et le nombre des décès attendus.

En conclusion, aucune des enquêtes épidémiologiques, couvrant la période 1968-1986 n'a mis en évidence une augmentation de la mortalité par cancer et par leucémie parmi la population voisine de l'usine de retraitement de La Hague.

Références :

- (1) - DOUSSET M.
Cancer mortality around La Hague Nuclear facilities
Health Physics 1989 ; 56 : 875-84.
- (2) - VIEL JF. - RICHARDSON S.
Childhood leukaemia around the La Hague nuclear waste reprocessing plant
British Medical Journal 1990 ; 300 : 580-1.
- (3) - HILL C. - LAPLANCHE A.
Overall mortality and cancer mortality around French nuclear sites
Nature 1990 ; 347 : 755-6.

CONSISTENCY OF EXTERNAL DOSIMETRY IN EPIDEMIOLOGIC STUDIES OF NUCLEAR WORKERS

Jack J. Fix and Ethel S. Gilbert

Pacific Northwest Laboratory
Richland, Washington USA

ABSTRACT

Efforts are underway to pool data from epidemiologic studies of nuclear workers to obtain more precise estimates of radiation risk than would be possible from any single study. The International Agency for Research on Cancer (IARC) is coordinating combined analyses of data from studies in the United States, Canada, and the United Kingdom. In the U.S., the Department of Energy (DOE) has established the Comprehensive Epidemiologic Data Resource (CEDR) to provide investigators an opportunity to analyze data from several DOE laboratories. IARC investigators, in collaboration with those conducting the individual studies, have developed a dosimetry protocol for the international combined analyses.

INTRODUCTION

In the pooling of radiation exposure data, there is significant concern regarding consistency of personnel exposure records between the different epidemiologic studies. Dosimetry working groups have been formed to evaluate this issue for pooled studies for the International Agency for Research on Cancer (IARC) and U.S. Department of Energy (DOE) Comprehensive Epidemiologic Data Resource (CEDR). A protocol has been developed for the IARC study by representatives of the United States, United Kingdom and Canadian studies. Recently, a dosimetry working group has been formed to provide recommendations to CEDR regarding retrospective and prospective radiation dose records. The IARC protocol addresses concerns related to the consistency of recorded dose as obtained from personnel exposure records, and requires evaluation of historical dosimetry practices by dosimetrists for each of the contributing studies.

EPIDEMIOLOGIC EVALUATIONS

Several epidemiologic studies of workers who have been exposed occupationally to external radiation are being conducted in the United States, the United Kingdom, and Canada. U.S. studies include workers at the Hanford site¹, at Oak Ridge National Laboratory², and Rocky Flats Nuclear Weapons Plant³; the U.K. studies include workers at the Atomic Energy Authority⁴, the Atomic Weapons Establishment⁵, and at the Sellafield Plant⁶, and the Canadian study is of workers at Atomic Energy of Canada Limited⁷. Analyses of data from these studies have included tests for an

association of cumulative radiation dose and mortality from many specific diseases, and have also included the estimation of excess risk per unit of dose.

Recently, pooled analyses of data from the three U.S. studies have been conducted⁸ and pooled analysis of the international studies are underway⁹. A major objective of these pooled analyses is to obtain more precise risk estimates than could be obtained from any single study, and to compare these estimates with risk estimates obtained through extrapolation from studies of the Japanese A-bomb survivors and other groups exposed at high doses. To accomplish this objective, it is important to evaluate the consistency of dose estimates across studies and across time. In addition, because risk estimates from high dose studies are generally based on organ doses, it is important to understand the relationship between recorded whole body doses obtained from personnel dosimeters and doses to various organs.

CONSISTENCY OF RECORDED DOSE

Consistency of recorded dose between epidemiologic studies is essential to the technical integrity of the pooled evaluations. There are several potential causes, administrative and technical, of inconsistency between different facilities or through time for a given facility. These causes of potential inconsistencies should be evaluated as an integral part of the epidemiologic evaluation. Typically, there is a need for documentation of the physical meaning of the recorded dose, particularly for facilities which began operation in the 1940s and 1950s. Potential causes of inconsistency should be evaluated for systematic differences, which affect the entire dosimetry system, and for differences in administrative practices, which are generally of most significance for recorded doses near the detection level of the dosimetry system.

Potential causes of systematic differences include the dosimetry technology, calibration methodology, dose algorithms, environmental dose correction and the physical definition of the calculated dose (i.e., exposure, absorbed dose in air, deep dose, etc.). Technical, administrative and compliance considerations are involved in the determination of practices adopted by facilities to record personnel dose. Facility specific technical and administrative practices may have significant effects on the recorded lifetime personnel dose for each individual. Prior to pooling data between facilities, an evaluation of the potential causes of inconsistency in recorded dose is necessary to ensure credibility of the analyses.

DOSIMETRY ASPECTS OF IARC PROTOCOL

A protocol for "Combined Analyses of Cancer Mortality Among Nuclear Industry Workers" was published by IARC in 1989⁹. This protocol includes a discussion of dosimetry data and the consistency of dose estimates, makes specific recommendations regarding documentation of dosimetry data, and specifies the dosimetry variables that are to be included in the IARC data sets. Results of the U.S. dosimetry working group evaluation were considered along with evaluations conducted in the U.K. and Canada in the development of the dosimetry portion of the IARC protocol. The IARC protocol contains several recommendations for dosimetry data. These include the following:

- Documentation of procedures and practices used to record dose
- Report external whole body dose as currently recorded
- Report external whole body dose components (i.e., penetrating photon and beta, neutron and tritium)
- Flag records with monitoring for internal depositions
- Flag records with confirmed plutonium, uranium or other nuclide internal depositions
- Comparison of recorded dose to deep dose
- Determination of organ dose as feasible

Prior to inclusion in the IARC study, a representative for each participating study completed a questionnaire on specifics of dosimeter design, dose assessment, monitoring and recording practices, radiation fields to which workers were exposed, etc. This information was used by IARC and the dosimetry subcommittee to conduct a preliminary evaluation of consistency of dose estimates used in different studies, and whether the reported doses can be converted to "deep dose", and to doses to various organs. More detailed documentation by the respective studies is encouraged. Recently, documentation of historical personnel dosimetry practices was published for Hanford¹⁰. This document describes dosimeters, calibration and dose recording practices for hanford facilities from 1944 through 1989.

REFERENCES

1. E. S. Gilbert, G. R. Petersen, and J. A. Buchanan. 1989a. "Mortality of Workers at the Hanford Site: 1945-1981." Health Physics, Vol. 56, 11-25.
2. S. Wing, C. M. Shy, J. L. Wood, S. W. D. L. Cragle and E. L. Frome. 1991. "Mortality Among Workers at Oak Ridge National Laboratory." Journal of the American Medical Association, Vol. 265, No. 11, pp 1397-1402.

3. G. S. Wilkinson, G. L. Tietjen, L. D. Wiggs, W. A. Galke, J. F. Acquavella, M. Reyes, G. L. Voelz, and R. J. Waxweiler. 1987. "Mortality Among Plutonium and Other Radiation Workers at a Plutonium Weapons Factory." *American Journal of Epidemiology*, Vol. 125, pp 231-250.
4. V. Beral, H. Inskip, P. Fraser et al. 1985. "Mortality of employees of the United Kingdom Atomic Energy Authority, 1946-1979." *Br Med J* 291:440-447.
5. V. Beral, P. Fraser, L. Carpenter et al. 1988. "Mortality of employees of the Atomic Weapons Establishment, 1951-1982." *Br Med J* 297:757-770.
6. P.G. Smith, A.J. Douglas. 1986. "Mortality of workers at the Sellafield plant of British Nuclear Fuels." *Br Med J* 293:845-52.
7. G.R. Howe, J.L. Weeks, A.B. Miller et al. 1987. A Study of the Health of the Employees of Atomic Energy of Canada Limited. IV. Analysis of Mortality During the Period 1950-1981. AECL-9442. Pinawa, Manitoba, Atomic Energy of Canada Limited.
8. E. S. Gilbert, S. A. Fry, L. D. Wiggs, G. L. Voelz, DL Cragle and GR Petersen. 1989b. "Analyses of Combined Mortality Data on Workers at the Hanford Site, Oak Ridge National Laboratory, and Rocky Flats Nuclear Weapons Plant." *Radiation Research*. Vol. 120, pp 19-35.
9. E. Cardis and J. M. Kaldor. 1989. "Combined Analyses of Cancer Mortality Among Nuclear Industry Workers." Internal Report 89/005. International Agency for Research on Cancer (IARC). Lyon, France.
10. R. H. Wilson, J. J. Fix, W. V. Baumgartner and L. L. Nichols. 1990. "Description and Evaluation of the Hanford Personnel Dosimeter Program From 1944 Through 1989." PNL-7447. Pacific Northwest Laboratory, Richland, Washington.

ACKNOWLEDGEMENT

This work was funded by the U.S. Department of Energy under Contract DE-AC06-76RLO 1830.

EFFECT OF CHITOSAN AND ALGINATE ON THE BIOKINETICS OF RADIOSTRONTIUM IN RATS

Y. Nishimura,* I. S. Wui,* K. Y. Kim, K. Watari,** J. Inaba,*** K. Imai

Division of Environmental Health, National Institute of
Radiological Sciences, 4-9-1, Anagawa, Chiba-shi 260, Japan,

* Department of Biology, college of Natural Sciences, Chonnam
National University, Gwangju 505-787, Chonnam, Korea,

** Division of Comparative Toxicology, National Institute of
Radiological Sciences, 4-9-1, Anagawa, Chiba-shi 260, Japan,

*** Department of Veterinary Medicine, Faculty of Agriculture, Iwate
University, 3-18-8, Ueda, Morioka-shi 020, Japan.

ABSTRACT

The chelating effect of natural polymers on the radiostrontium was investigated on a single ingestion with chitosan and a long day pre-feeding diet with alginate in rats. After dosing of chitosan, Sr-85 was ingested orally to the rats and the whole-body retention of Sr-85 was investigated. The whole-body retention of the chitosan treated rats was lower than that of non-treated control.

INTRODUCTION

The radiostrontium, one of the nuclear division products flown out to the environmental area by the nuclear power plant accident and nuclear weapon accident. It brings out of a serious genetic disease like Bone Cancer, Hypocemia, etc. Therefore, it has been discussed out an important human health problem that the chelating of radiostrontium and the removing out of the body before or after accumulating to the bone. Chitosan derived from chitin which is a cellulose-like biopolymer distributed widely in nature, especially in shell fish, insects, fungi and yeast, is known to be one of the natural chelating agents. The purpose of the present study is to investigate whether chitosan can be applied to the animal and human body and the long day pre-feeding effects of alginate in order to reduce the bioavailability of radiostrontium in foods. Many chelating agents—that is, DTPA, CDTA, EDTA, etc were reported as effective medicines. But they have some toxicity. So, we need a serious check to use of them at the real clinic experiment. Therefore, the discovery of non-toxic natural chelating polymer is quickly needed.

MATERIALS AND METHODS

Experimental animals used were male rats of the adult wister strain and 8 weeks of age, weighing about 250-300g, bred and supplied by the animal and plant supply section of National Institute of Radiological Sciences were used in this experiment. The rats were provided with a standard cubed diet(Fubashi Farm co. Fubashi, Chiba, Japan). Radiostrontium chloride ($^{85}\text{SrCl}_2$) with a specific activity of 430MBq/mg Sr was obtained from England Nuclear, U.S.A through Radioisotope Association, Japan. This was diluted to 15KBq/ml of solution with normal saline solution and administered 0.5ml per one rat. Chitosan (Hwasung K.K, Tokyo, Japan) is slightly soluble in distilled water and alkali, it is soluble in some organic acids. 0.8, 2, 3% of chitosan solution was prepared by dissolution in 1N acetic acid. And also 0.8, 2, 3% of water soluble chitosan (Hwakwang K.K, Tokyo, Japan), the chemical form of 45-55% deacetylated chitin, solution was prepared by dissolution in distilled water. Chitosan solution was orally given and immediately after than $^{85}\text{SrCl}_2$ was administered to rats using a stomach tube. The whole-body retention of Sr-85 was determined by in vivo counting. The percent of alginate food was given to rats during 10days and Sr-85 was administered orally.

CONCLUSIONS

The whole-body retention of Sr-85 determined by in vivo counting was lower than that of control rats which were not given chitosan.(Fig.1) And the effects were differented along the concentration variation of chitosan.(Table1) The activity ratio in urine and feces for chitosan-treated rats was higher than control rats.(Fig.2) The whole-body retention of Sr-85-alginate treated rats was decreased sharply compared with control rats.(Fig.3) These results suggested that chitosan and alginate can be used as a drug to reduce bioavailability from gastrointestinal of ingested radiostrontium.

REFERENCES

1. ICRP Publication 30, 1967, Pergamon Press. Oxford, pp. 77-78. Keisuka K., Yoshiyuki K., Shin-ichiro N., and Mami K., 1989, Facile Preparation of Water-Soluble Chitin from Chitosan, Chemistry letters, pp. 1597-1598.
2. Kimie A., Toyosuke K., and Takao F., 1968, Toxicity of Chitosan, Bull. Tokai Reg. Fish. Res. Lab., 56, pp. 90-94.

3. Riccardo, A. A. Muzzarelli, 1971, Selective collection of trace metal ions by precipitation of chitosan, and new derivatives of chitosan, *Anal. Chim. Acta*, 54, pp. 133-142.
4. Satoshi F. and Haruzo I., 1987, Toxicological study of DTPA as a drug (III) side effect of orally administered Zn-DTPA to Beagles, *Hoken Butsuri*, 22, pp. 439-444.
5. Taylor, D. M., 1962, The absorption of calcium, strontium, barium and radium from the gastrointestinal tract of the rat, *Biochem. J.*, 83, pp. 25-29.
6. Taylor, D. M., 1967, *Strontium metabolism*, Academic Press, London, pp. 175-180.

Table 1 Whole-body retention of Sr-85 in rats after oral administration

Days after dosing	Control	Chitosan (0.8%)	Chitosan (2%)	Chitosan (3%)	Continuous injection (3% Chitosan)	Alginate (2%)	Alginate pre-feeding (10%)
1	15.3±4.4	15.0±6.4	13.0±1.9	8.8±2.6	12.7±4.8	10.3±4.8	7.9±2.4
2		10.7±6.2	8.1±1.7	6.7±1.7	7.7±3.9		3.5±0.4
3	11.5±1.2			6.7±1.6	6.7±3.8	13.4±4.9	3.2±0.5
4		9.7±5.9	6.7±1.4	6.0±1.4	6.7±3.7		3.1±0.5
5				5.7±1.4	6.3±3.7	12.7±4.7	2.9±0.5
6	11.0±1.1						
7		9.0±5.5	6.6±1.3	5.4±1.3	6.0±3.5	11.8±4.3	2.8±0.4
14	9.4±0.7	8.4±5.0	6.0±1.2	4.8±1.1	5.5±2.3	11.6±4.3	2.5±0.4

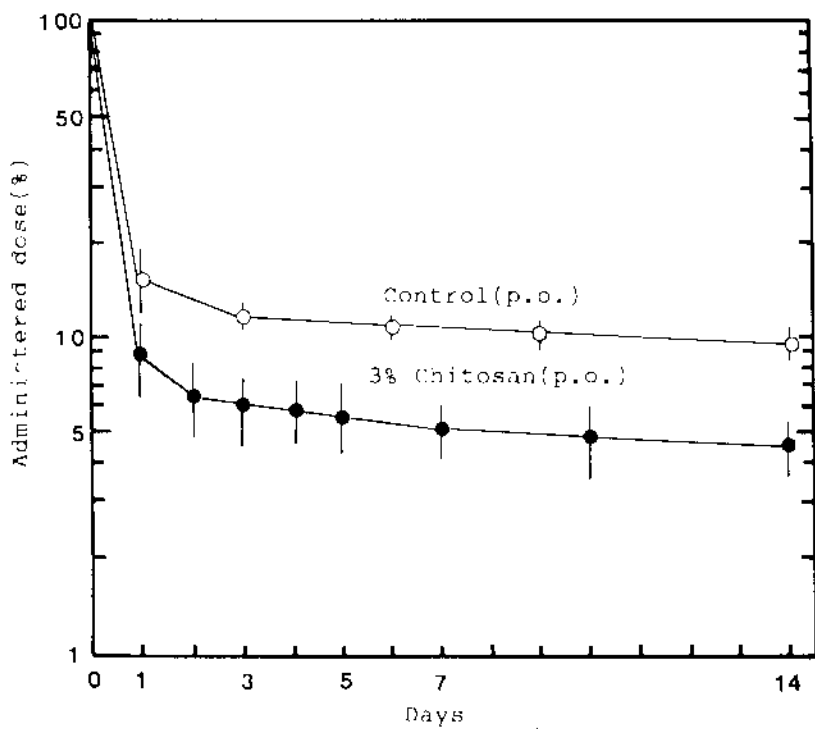

Fig.1 Whole-body retention of Sr-85 in rats after a single oral administration.

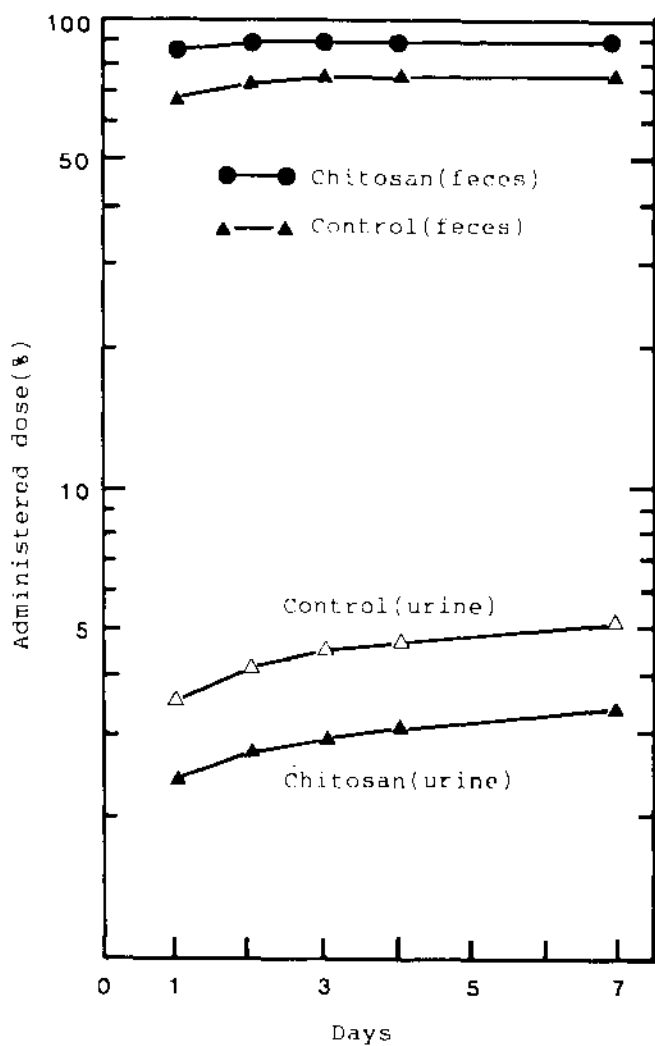

Fig.2 Cumulative excretion of Sr-85 in rats after a single oral administration.

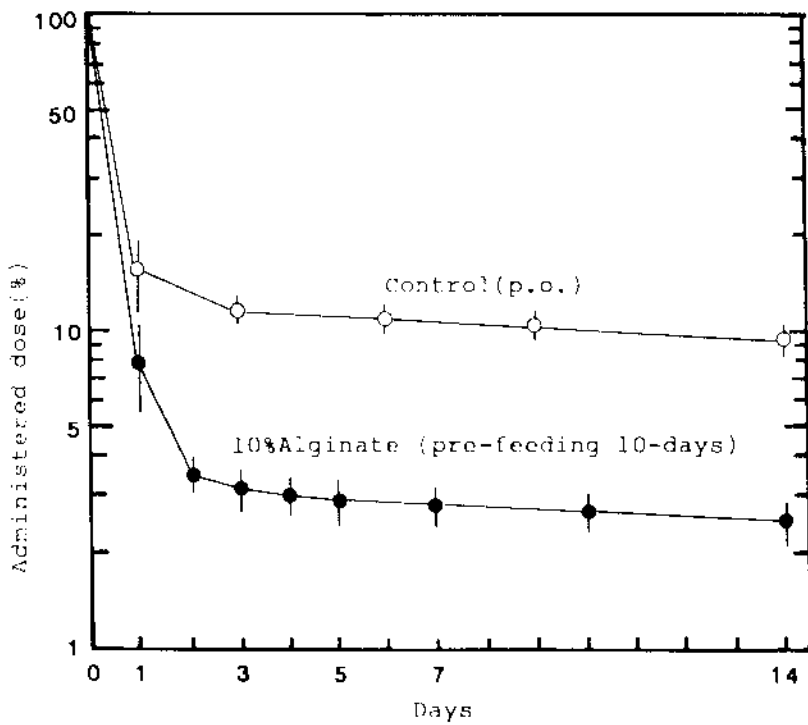

Fig.3 Whole-body retention of Sr-85 in rats after a single oral administration.

NONSPECIFIC CELLULAR RESISTANCE DISORDERS
INDUCED BY LOW DOSES OF RADIATION

I. Voltchek, E. Kostyushov, L. Filyov, V. Dyachek, I. Izyumtsev,
A. Tyaptin, I. Popov, Yu. Medvedev, L. Goncharova

Department of Extreme Medicine, Leningrad Institute of
Advanced Medical Studies; All-Union Research Institute of Highly
Pure Biopreparations, Leningrad, USSR

Some integral proofs of nonspecific cellular resistance was studied at liquidators of the consequences of Chernobyl AES crash 4-4,5 years ago radiation influence in doses 20-25 rem. The share of blood mononuclears with viral inclusion bodies and degree of its viral affect, metabolic and phagocytic monocyte activity in NBT-test (L. Filyov et al., 1985) were appraised. Lysosomal-cationic test was used for the revealing of functional state of granulocytes.

It was established that at all patients influenced by low doses of radiation there were increased proofs of viral affect of mononuclears in comparison with control group of healthy donors. At the same time most liquidators had functional defects of monocytes and granulocytes.

Consequently, there may occur nonspecific (antiviral) cellular resistance disorders under the influence of radiation low doses which in its turn may lead to development, unfavourable course, chronization of infection diseases, forming of immunocomplex pathology, neoplastic processes. The perspective way of prophylaxis radiation low doses induced unfavourable consequences is the correction of nonspecific cellular resistance disorders (Olifen, Interlock).

RADIATION PROTECTION - IS IT SCIENCE?

Dr B M Hartley

**Physicist in Charge, Radiation Health Section
Health Department of Western Australia**

Radiation Protection brings together a variety of disciplines which would claim to be sciences. The amalgamation of these into radiation protection is done under the guise of Scientific Committees and by Scientists. Can the result of this amalgamation still be described as a science? If not, our perception of the discipline and attitude to its practice may need to change. The attitude of the media and that of the public to our profession may also change if radiation protection is recognised not to be a science.

An analysis of the basis of science would indicate that Radiation Protection is not a science. The question is then posed; What is the discipline of Radiation Protection?

INTRODUCTION

Whether radiation protection is 'science' or not should affect the way it is practised and the way it is considered by the public at large. If it is science there is an expectation of accuracy, precision and consistency and therefore the possibility of widespread acceptance of decisions based on its application. If it is not science the public at large, and especially those who may be affected by its practice, may have a role in determining how it is practised. Radiation protection may then become subject to political, philosophical and practical pressures which influence decisions on the application of its systems.

WHAT IS SCIENCE?

It is common to distinguish between two types of conventions which control our actions. The first of these are the natural laws which define such properties as the law of gravity or the laws of thermodynamics; these are laws which can be investigated by the scientific method. Other conventions are the so called normative laws which are the conventions by which people control their lives and in which society has exercised a choice. Such laws often cannot be rationalised by scientific investigation.

Such a classification is not precise as there are some natural laws which, for a variety of reasons, cannot be investigated whilst normative laws imply that an option or choice has been exercised. Some normative laws of behaviour may, however, arise from natural laws or be required for survival. The distinction between normative and natural can, as a result, become blurred.

Without being too precise science could be defined as being the process of investigating natural laws. In investigating natural laws a common procedure is to devise a hypothesis and test it by experiment. The linear hypothesis of radiation protection may be considered such a hypothesis, but it is not testable at certain doses and dose rates. As it cannot be investigated scientifically it is an invalid scientific hypothesis.

A more scientifically justifiable hypothesis would be one of no effect at low doses and dose rates. Such an hypothesis is falsifiable by application of scientific methodology and is therefore scientifically valid hypothesis.

WHAT IS RADIATION PROTECTION?

The principal foundations of radiation protection are the disciplines of epidemiology, modelling and laboratory studies. These disciplines are identifiable as sciences since they seek to investigate natural laws by the testing of hypotheses through experiment. The phenomenon which is being investigated in these studies is that which relates the effect of radiation exposure to the level of exposure on the ensemble of the human population; an identifiable natural law.

The syntheses of the results of epidemiology, modelling and laboratory studies has given us some confidence about the relationship between radiation exposure and response. The International Commission of Radiological Protection has, as a result, devised a system of radiation protection with its basis being exposure control by justification, optimisation and limitation.

These three tenets of radiation protection do not evolve readily from natural laws. Justification and optimisation, require a judgement of the community value placed on the detriment which exposure to radiation imposes on the community. The limitation of exposure to an individual is derived from the ensemble of human responses. It may not be appropriate to apply a dose-response law to an individual when it is derived from grouped data. Its application departs from the normal practices of science. All three involve ethical considerations.

The setting of standards for Radiation Protection is clearly in the area of public policy and ethics although its basis is scientific.

An alternative to optimization would be a policy of "Prudent Avoidance" of exposure and this would be more in keeping with the adoption of the null hypothesis for effects of radiation at low doses.

Since radiation protection is commonly pursued by persons who have scientific training there is a tendency to confuse the application of scientific method with science. Attempts have been made to adopt a scientific approach to justification by placing a value on a human life and assessing the loss of life or health against the benefits to be had by others. A similar paradigm is used to optimise a practice.

In giving advice the ICRP could confine themselves to statements of the known data on levels of radiation which produce known biological effects. Such levels are well above those which are used as annual occupational radiation limits. By adopting the non falsifiable linear hypothesis the ICRP alters the profession of radiation protection from purely scientific to pseudo-scientific.

SETTING OF RADIATION STANDARDS

The means by which standards for radiation exposure are set should depend on whether the process is one which set natural or normative laws i.e. scientific or conventional. Even the necessity to establish radiation protection standards in law would indicate that they are normative laws and not natural ones. Recommendations for limits can derive either from an expert group or from community based groups. Included among the community groups may be workers groups with representatives on decision making bodies.

It is normally considered to be the role of politicians to determine policy but in this instance their input has been small or non-existent. In some countries there is a growing call for tripartite agreement on occupational limits with the persons occupationally exposed having a major role in determining limits. Participating workers often call for exposure limits lower than those recommended by the ICRP taking the determination of limits further away from the scientifically verifiable.

The groups making recommendations will nevertheless consider matters which are, in the above definitions, not scientific. If the matters are scientific the uncertainties are often such as to render their consideration by scientists inappropriate. If recommendations are only made by scientists, the public expects greater precision than can be given. Radiation protection cannot respond adequately through science alone.

Bodies setting radiation protection standards should understand that they are setting policy not science. Optimisation and justification tend to demand the use of a scientific method which is inapplicable in a policy area. When effects are so uncertain a policy of either acceptance or avoidance of exposure could be adopted instead of optimisation.

At levels where effects are quite uncertain a policy of acceptance could be adopted. Such a method of radiation control is clearly then a policy matter but is based on the proper scientific hypothesis of no effect of radiation exposure at low doses. Optimisation would only be applicable where radiation effects were known and demonstrable.

THE FUTURE FOR RADIATION PROTECTION STANDARDS

As the ICRP and Regulatory Bodies have, as a policy matter, set exposure limits outside the bounds of scientific evidence, one may question whether this should continue. The success of such a process should be a determining factor in deciding.

The ICRP can point to many successes in its long history including the evidence of low exposures and health risks in most radiation industries. The cost of the reduction in exposures must however be balanced by the benefits derived. It is certain that the ICRP's assumption of continuing detrimental effects of radiation at low levels has caused the expenditure of considerable effort which could have been directed at more tangible and direct hazards. To balance this, however, emphasis on radiation has led to reductions in other industrial hazards.

A new Radiation Protection System could be considered to replace the current system of radiation exposure control.

- (1) Radiation exposure at high levels has been shown to produce detrimental health effects. Limits of exposure of single persons should be set to be below such levels.
- (2) Where large numbers of persons may be exposed to radiation as a result of a practice and where individuals may be exposed to levels which are a significant fraction of the limit, radiation exposure should be controlled by optimisation.
- (3) Where individual radiation exposures are low a policy of prudent avoidance of exposure should be employed. At levels at which it is unfeasible to demonstrate harmful effects on individuals or groups a policy of acceptance of the radiation exposure may be adopted where the use of radiation is shown to produce other positive benefits.

This system of radiation protection is based on a scientifically valid hypothesis and includes explicit to the statement on formation of policy implicit in setting of any standards.

\bh160991.sg

Training and Retraining of Radiation Protection Technicians

L. Warming, J. Søgaaard-Hansen, B. Lauridsen and P. Hedemann Jensen
Risø National Laboratory, DK-4000 Roskilde, Denmark

Abstract

A new training programme for health physics technicians has been based on a textbook on health physics (700 pages in Danish). Two technicians have been trained according to the programme. Following this an extensive programme was initiated for the retraining of all technicians. Both programmes consists of lectnres, theoretical problems and practical exercises.

Introduction

Risø National Laboratory was founded in 1956 and in the following years several nuclear facilities were build. Today, two reactors, several nuclear laboratories and a nuclear waste treatment plant are in operation.

A section for applied health physics is responsible for radiation protection at the nuclear facilities and at other laboratories at Risø, where radioactive materials, ionizing radiation and lasers are used. The section consists of four health physicists (HPs) and 13 radiation protection technicians (RPTs). A few of the technicians have been with the section for about 30 years.

New comprchensive programmes for both basic training and retraining of RPTs have been made. All training is done by the HPs and senior RPTs. The main part of the teaching is based on the first draft of a textbook on health physics (approximately 700 pages in Danish). The book has been tailor-made for the RPTs. It is comprehensive and self-contained; a good basic school education is needed to read the textbook. The textbook is suitable as a handbook in the daily radiation protection work for both the HPs and RPTs. The authors of the book are the HPs (also authors of this paper), and the retired senior RPT who previously was in charge of training of the RPTs.

Basic training

The basic training takes 8 months. Trainees are recruited among people with a technical background such as laboratory assistants or mechanical technicians. The basic training consists of lectures (400 h), theoretical problems and laboratory exercises (200 h) and on-the-job training (400 h). The lectures give the theoretical basis of radiation protection and cover the subjects of the textbook, such as: atomic physics, interaction of ionizing radiation with matter, dosimetry, radiation biology, radiation protection philosophy, legislation and local rules. Further the various nuclear installations at Risø are described with emphasis on radiation protection matters. The laboratory exercises introduce measuring techniques and data analysis. The lectures are given by the HPs, who also formulate the theoretical problems, while senior RPTs are in charge of the laboratory exercises and the on-the-job training. The training is not identical for all new trainees, but it is adjusted slightly to fit the educational background of the individual.

The aim of the basic training is to reach a level of education that enable the RPT to act independently and:

- give advice in work-situations both on-line and in the planning phase
- perform standard analysis on samples (γ -spectrometry, gross α - and β -counting)
- report results and evaluations in writing
- present problems for the HPs
- answer questions on radioactivity and radiation protection from the staff of the installations
- handle emergency situations.

The trainees are evaluated by a written (4 h) and an oral (1-2 h) examination. The man-power required for running a basic training programme including preparatory work is approximately 1000 HP hours and 500 senior RPT hours.

Retraining.

An extensive retraining programme was initiated for the first time in 1990 and will run for a period of two years. It is an assembly of teaching sessions, and each session has three parts:

- two double lectures on separate subjects, lasting a morning (3 hours),
- a set of theoretical problems
- a practical exercise.

The programme has about 20 sessions in total (one session a month). Most subjects are dealt with in several sessions (months) depending on their importance. During the programme the technicians will become familiar with the different chapters of the health physics textbook.

The two set of lectures are always dealing with two separate subjects and they are given by two different teachers. The level of the teaching is set rather high and is higher than needed for the RPT's daily work.

With each lecture follows a set of theoretical problems to be solved and the answers to be handed in before the next lecture. An example is the calculation of the internal dose, the tritium concentration in the body as well as the concentration in the urine at different times after two separate intakes of tritiated water.

The practical problems aim at making the technicians familiar with all health physics instrumentation available at the health physics laboratories. This is among others, survey instruments, γ -spectrometers, α - and β -counters. The problems chosen for the practical exercises are specifically selected to be closely related to the daily use of the instruments. An example of a practical exercise is calibration of an air-monitor for a specific radionuclide. When the RPTs have made the measurements they have to write a report. The report should present the purpose of the exercise and describe the work carried out together with the measured data, the calculations and a discussion of the results. The report should be written in a manner that can readily be understood by their colleagues. Also this report should be handed in before the next session.

From reading and correcting the problems and reports handed in, it is easy for the teachers continuously to get an impression of the educational level of the technicians.

Experience - Results.

The training programme has been used once for two new RPTs and has proved very effective, although some minor corrections were needed. The new RPTs have now been working for two years and accomplish their work satisfactorily. During the teaching period parts of the draft of the health physics textbook were written in parallel with the teaching which helped to make the content directly aimed at the RPTs.

The extensive retraining programme runs for the first time and we are now about half-way through the programme. All the RPTs have expressed a need for retraining before the programme was initiated and they appreciate the information they are presented with. The two "youngest" RPTs do also participate in the retraining programme. Although it is only two years ago they finished their basic training, they find the repetition useful. The practical experience they have gained in these two years has clarified for them some of the theoretical aspects in the training programme.

The educational level of the "old" RPTs has increased considerably. They are now able to make better use of the different instruments in the laboratories. Measurements and observations during important operations are being very well documented. This is essential both for record keeping and for communication to and from the RPTs working in shifts and in reports to the HPs. The RPTs find themselves with a better background for their advice to those workers, they supervise.

The teaching has been done in an informal way, and the enthusiasm of the teachers(!) seems to have spread to the RPTs. During the lectures the RPTs have contributed with practical examples from their local working area. This helps linking the theoretical subjects with the practical work and it is a good exchange of information among the different working places. This also makes it more easy for the RPTs to help their colleagues at other installations. During the teaching sessions and the following discussions the HPs and the RPTs have got to know each other better and the HPs have now a much better knowledge of the capabilities of the individual RPT.

The teachers have also benefitted both from writing the book and from the teaching itself. As always, teachers gain a deeper knowledge of a subject when they have to teach it.

So far the retraining seems to be so much a success that it is being discussed to let it continue in a less intensive manner.

COST-EFFECTIVE RADIATION PROTECTION FOR SCHOOLS AND COLLEGES
IN THE UNITED KINGDOM

K W Bowker

Hinton & Higgs (Consultants)
Abingdon, Oxon
United Kingdom

ABSTRACT

This paper describes how schools and colleges in the United Kingdom can meet the requirements of the Ionising Radiations Regulations 1985 in a simple and cost-effective manner.

INTRODUCTION

In the United Kingdom, the storage, handling and use of radioactive materials is controlled by the Ionising Radiations Regulations 1985. Students, usually in the 16-18 age group studying Advanced Level Physics in schools and colleges carry out a number of practical experiments using radioactive sources. The sources are principally closed sources of low activity and their usage is of corresponding low risk. Nevertheless, there is a need for the school or college to comply with the legislation and this paper describes how this can be achieved in a cost-effective way.

SOURCES USED

Appendix 1 shows typical closed sources used in the Advanced Level Physics course, together with their activities. In addition, cloud chamber sources are of very low activity (740 Bq). Thoron generators typically use 100 grams of thorium carbonate powder in polythene squeeze bottles. Radioactive rocks sets are a mixture (usually for four different rocks) of naturally occurring minerals containing radioactivity.

MAIN POINTS OF THE LEGISLATION

An essential aspect of the legislation is the requirement for the employer to appoint a Radiation Protection Adviser (RPA) who, as the title implies, provides advice on all aspects associated with the safe use of radiation sources in the school or college. In addition, each establishment must appoint a Radiation Protection Supervisor (RPS) to oversee the day to day arrangements for the radiation sources. The person usually appointed as RPS is the head of physics in the school, occasionally the head of science.

The main duties of the RPS in a school or college are principally to ensure that:

- 1 The list of sources is kept up to date and to notify the RPA of any changes;
- 2 Sources are kept in a locked, fire-proof cabinet, properly signed;
- 3 A log book is kept with the sources and that details of source movements are being maintained;

- 4 Local rules have been formulated and are kept up to date;
- 5 Leakage tests on appropriate closed sources are carried out;
- 6 To arrange, usually via the RPA, for the safe disposal of unwanted sources.

LEAKAGE TESTING

The Regulations require that all closed sources with a surface dose rate greater than 100 microsieverts per hour and with any dimension greater than 5mm are tested for leakage every twenty-six months. The method of test is a wipe followed by counting the activity removed onto the wipe. The limit of leakage test activity is 185 Bq. A sensible and cost-effective arrangement that can be adopted in schools involves an initial in-house screening process which is followed, but only where necessary, with testing by an appropriate external organisation. The RPS carries out the wipe test using a moistened paper and counts the wipe using school counting equipment. Where a significant quantity of activity is found on the wipe, the RPA is notified and arrangements for quantitative testing made. Schools must keep records of the test in a format laid down by the Regulations.

Most Radium-226, Strontium-90 and Cobalt-60 sources used in schools require leakage testing. In the author's experience, an insignificant few are found to have any measurable leakage activity. Thus, for the main part, this requirement of the Regulations can be carried out in-house by the school at a time to suit their convenience and at minimal cost.

TRAINING

The Regulations require that a RPS is not appointed until such time as he/she is aware of the Regulations such as they affect their particular work activity. Training is therefore essential. All RPS's are expected to attend a training course, typically of one half day's duration. A syllabus for a school/college RPS training course is shown in Appendix 2.

RADIOACTIVE WASTE DISPOSAL

In addition to commercially purchased sources, schools and colleges often 'acquire' additional sources, usually from well-meaning parents or teachers themselves. These 'acquired' sources tend to be either naturally occurring ores/minerals or apparatus containing luminising material. Many contain more activity than the commercially bought sources. In most cases, the teacher in charge is pleased to see such sources put for disposal. A collection of unwanted sources, including those commercial sources that have decayed to a level where they are no longer useful, is most cost-effective when carried out on a basis involving as many schools as possible in an area. Disposal by individual schools is not recommended on cost grounds.

CONCLUSION

Perhaps with the exception of thoron generators, the use of radioactive sources in schools is of a low order of risk. Compliance with the UK regulations can be achieved simply and in a cost-effective manner. There is a further positive benefit in that schools and colleges are able to demonstrate to their students, whose opinions are at a critical stage of development, a sensible radiation protection regime.

APPENDIX 1

CLOSED SOURCES USED IN SCHOOLS AND COLLEGES

SOURCE	TYPICAL ACTIVITY (kBq)
Americium-241	185
Cobalt-60	185
Strontium-90	185
Radium-226	185
Plutonium-239	3.7

APPENDIX 2

SYLLABUS FOR RADIATION PROTECTION SUPERVISOR TRAINING

Radiation harm.
Radiation protection objectives and methods by which objectives are achieved.
Dose limits - units of activity and dose.
Methods of dose reduction.
Summary of typical sources used in schools and associated doses and risks.
Thoron generators, cloud chamber sources.
Naturally occurring radioactive sources used in schools.
Ionising Radiations Regulations 1985 - main points of legislation as they affect the school.
Role of the Radiation Protection Adviser and Radiation Protection Supervisor.
Duties and responsibilities of the Radiation Protection Supervisor.
Local rules.
Waste disposal requirements.
Leakage test - demonstration - records to be kept.

EDUCATIVE HEALTH PHYSICS

R J VETTER⁽¹⁾, M C O'RIORDAN⁽²⁾

⁽¹⁾ B-31 Medical Sciences, Mayo Clinic,
Rochester MN 55905, USA
Fax Number: 0101 507 284 0150

⁽²⁾ National Radiological Protection Board
Chilton, Didcot, Oxon OX11 0RQ, UK

There is more to education in radiation protection than curricula, courses and certificates. In a broader sense, education implies the provision of knowledge, the development of competence, and the promotion of understanding. These purposes are served by Health Physics, the journal of radiation protection. The leading role of the journal is supported by an Advisory Board composed of members of the IRPA Publications Commission.

A review is presented of the diversity of material in Health Physics throughout the last few years and set against the historical background. Expansion in the range of topics is described as well as the increase in didactic content both theoretical and operational. The global range of contributions is noted as is the attempt to provide an international perspective on developments in the discipline. Plans for the future are discussed.

ooOoo

COMPARAISON DES RISQUES DES DIVERSES ENERGIES POUR LA
PRODUCTION D'ELECTRICITE

M. BERTIN, D. HUBERT, J. LALLEMAND, Ph. ROLLIN

ELECTRICITE DE FRANCE - Comité de Radioprotection
PARIS - FRANCE

COMPARED RISKS AMONG ELECTRICITY GENERATING ENERGIES

ABSTRACT

When comparing risks among the different electricity generating energy sources, demonstration has been made that nuclear electricity "performance" is comparable to that of natural gas and far better than oil and coal's. The greenhouse effect must of course be taken into account. Nuclear and hydro power stand out as non-contributing to this effect. We must keep in mind that energy requirements will increase in the next years, because of demographic development and economic growth in the Third World. Therefore, a large-scale use of nuclear power will become necessary.

INTRODUCTION

Les comparaisons des risques des diverses énergies utilisées pour produire de l'électricité ont commencé il y a environ 20 ans.

Leur but est de "situer" l'importance des risques dus à l'emploi du "nucléaire" par rapport à ceux dus à l'utilisation d'autres énergies : elles concluent toutes que pour produire de l'électricité les risques de l'industrie nucléaire sont moindres que ceux du charbon ou du pétrole et du même ordre de grandeur que ceux du gaz naturel [1].

Leurs faiblesses sont cependant nombreuses :

- manque ou insuffisance de données,
- absence de dénominateur commun pour juger des effets sur la santé.
- variabilité très grande des résultats suivant les conditions d'exploitation.
- etc...

Les publications récentes [2,3,4] affirment que malgré Tchernobyl la hiérarchie indiquée ci-dessus est toujours valable bien que l'évaluation des conséquences de l'accident soviétique ne soit pas encore terminée.

PRISE EN COMPTE DE L'EFFET DE SERRE

Cependant le bilan de telles études doit être complété par la prise en compte de l'effet de serre et, par extension, de tous les problèmes d'environnement ayant une dimension à l'échelle de plusieurs pays ou d'un continent : pluies acides, dépérissement des forêts, pollutions transfrontières par les dérivés soufrés et azotés.

Le meilleur exemple est celui de l'effet de serre.

Il est dû essentiellement au CO₂ mais aussi au méthane, aux oxydes d'azote, aux chlorofluorocarbones ou CFC et aux hydrocarbures imbrûlés.

Il concerne toute l'atmosphère terrestre ; ce n'est donc pas un problème à résoudre au plan local ou régional. Il implique une politique énergétique commune.

C'est un problème dont l'évolution est lente et qui oblige à une politique à très long terme.

Cette évolution paraît difficilement réversible puisque les quantités de CO₂ produites paraissent supérieures à celles qui peuvent être éliminées par les étapes suivants du cycle du carbone.

Tous les combustibles carbonés y contribuent : charbon, lignite, produits pétroliers, gaz naturel mais encore le bois et, plus généralement la biomasse, la combustion des déchets et en particulier des ordures ménagères.

C'est une pollution différente des pollutions classiques ; elle modifie l'environnement et agit par le cumul de substances modifiant le climat. Elle n'agit pas directement sur l'homme.

Parmi les énergies actuellement utilisées à grande échelle seuls le nucléaire et l'hydraulique ne sont pas concernés. Ceci est la première conclusion.

QUELLES SONT LES CONSEQUENCES DE L'EFFET DE SERRE

L'augmentation progressive du taux de CO₂, de méthane et d'oxydes d'azote dans l'atmosphère est certaine. L'élévation lente mais réelle de la température atmosphérique paraît très vraisemblable. Les conséquences pour l'environnement semblent n'être que partiellement prévisibles mais elles ont peu de chances d'être réversibles dans les conditions actuelles de croissance de la consommation d'énergie. Les conséquences pour la santé sont inconnues mais des modifications des conditions de vie, du climat, de l'agriculture sont à peu près certaines.

Tout ceci devrait amener à réviser les politiques énergétiques : d'ailleurs les producteurs d'énergies fossiles qui à énergie égale produisent le moins de CO2 revendiquent déjà un rôle accru : c'est le cas du gaz naturel par rapport au charbon. L'essentiel et c'est notre deuxième conclusion est que la nécessité de développer l'électronucléaire est ainsi devenue évidente pour un nombre croissant d'hommes politiques et surtout de scientifiques de disciplines diverses [5].

SOLUTIONS

En effet on propose de réduire (ou de stabiliser) la consommation d'énergie pour diminuer la production de ces gaz favorisant l'effet de serre. On ne peut qu'être sceptique sur la réussite de telles mesures et on peut même se demander si ce n'est pas une façon de refuser de poser les vrais problèmes.

. L'augmentation de la population mondiale est extrêmement rapide (population 91 : 5,4 milliards d'habitants - prévision 2025 : 8,6 milliards d'habitants) et ceci en raison essentiellement de l'accroissement de la population du Tiers Monde.

. Or l'évolution du tiers monde passe par le développement économique donc par le développement de la consommation d'énergie ; le manque de moyens financiers de ce pays fait que la protection de l'environnement n'est pas une de leurs priorités ; les économies d'énergie sont soit imposées par le manque de ressources d'un pays, soit un luxe de pays riches.

. Cependant il sera évidemment nécessaire de freiner l'augmentation de la consommation d'énergie puisque les réserves sont limitées ; elles représentent quelques dizaines d'années de consommation pour le pétrole, entre 60 et 100 ans pour le gaz naturel, plusieurs siècles pour le charbon, et certaines énergies non encore exploitées comme les asphaltes et les schistes bitumineux sont encore plus polluantes que le charbon. La consommation de la biomasse et du bois augmente l'effet de serre de deux façons : la déforestation et la production de CO2.

. Il sera évidemment nécessaire d'utiliser toutes les énergies disponibles tant qu'une révolution technologique ne permettra pas de révolutionner la production d'énergie, et l'électronucléaire, en particulier dans les pays économiquement développés, sera amené à se développer et ceci paradoxalement, n'en déplaise à certains, pour des raisons sanitaires et, deuxième paradoxe pour que ce développement ait une influence significative il faudra qu'il soit très important. Ceci est notre troisième

conclusion. Le surgénérateur est peut-être la seule filière à la mesure des besoins d'autant qu'il est peut-être aussi la solution pour éliminer les nucléides à très longue période.

BIBLIOGRAPHIE

1. Les risques sanitaires des différentes énergies. Actes du Colloque SFEN, 24-26 janvier 1980, 658 p. GEDIM.
2. A.F. FRITZSCHE. The Health Risks of Energy Production. Risk Analysis, 9, 565-577, 1989.
3. Council on Scientific Affairs. American Medical Association. Medical Perspective on Nuclear Power. JAMA, 262, 2724-2729, 1989.
4. Senior Expert Symposium on Electricity and the Environment. Comparative Environmental and Health Effects of Different Energy Systems for Electricity Generation. Helsinki, Finland, 13-17 May 1991., 72 p.
5. Sous-Commission d'Etudes Médicales. Union Internationale de l'Industrie du Gaz. Rapport d'activité. 18ème Congrès Mondial du Gaz, Berlin, 8-11 juillet 1991.

**RADIATION PROTECTION TRAINING
AT ELECTRICITE DE FRANCE**

**Evelyne Guinard
Deputy Training Division Manager
Nuclear and Fossil Generation Division**

ABSTRACT

Training in radiation protection is a part of EDF's general risk prevention training program. Operating personnel who work in controlled areas receive specific training focused on ensuring awareness of the risks involved at each phase of an operation. Specific training actions also have been designed for specific target populations. The program calls on an innovative tool : a simulator is used for training of operators in managing accidents following steam generator tube breaks. This simulator is linked to a special training-oriented expert system in order to generate key parameters, including graphs showing changes in dose equivalent at the site boundary.

During the development of France's PWR nuclear plants, radiation protection was taught as a specific subject. Today, we feel that it can be integrated within a broader context, i.e. training in risk protection, which encompasses both radiation protection and so-called conventional safety training. This thinking has led to preparation of a training plan which targets all personnel -- operating staff, supervisors and managers -- who might take actions in a controlled area.

This plan starts with an initial training segment, which is in turn divided into two parts:

- The first 5-day session takes place no later than several weeks after a new employee has joined a nuclear power plant. This session provides the basic knowledge required to issue level one personnel certification (level one means operating personnel taking action either alone or under the supervision of a supervisor with level two certification).
- The second session lasts four days and takes place one year later.

The objective of this initial training is to ensure that all persons who will subsequently work in controlled areas are aware of the need for:

- integration of all components of safety information, particularly those related to radiation protection, within a coherent whole during every phase of workplace action: preparation, execution and experience feedback;

- knowledge of the reasons for which regulations have been defined and are applied;
- improved ability to implement behavior aimed at risk prevention during all workplace actions, with an emphasis on cooperation within the work team.

In order to achieve these objectives -- which are directly linked to awareness of the importance of the issues involved -- the acquisition of information strictly speaking has been accorded secondary importance. Rather, the training courses emphasize reflection, situational exercises, tours of work sites and case studies.

Following this first training program, a second program has been developed within the same context. This program is designed specifically for personnel with the following functions in controlled areas:

- work preparation manager,
 - supervisor,
 - safety supervisor,
 - safety instruction manager,
 - shutdown manager,
 - supervisor,
- as well as certain other categories.

The goal of this action is to ensure that all these staff take risk prevention into account during preparation of their work, as well as during actions taken before, during and after the tasks they perform in controlled areas. The training course seeks to develop their ability to:

- analyze work situations, especially in terms of identifying potential risks;
- apply the operating procedures and resources required to control risks and prevent any member of the work team from having an accident during all three shifts (particularly for work on a given site with other teams);
- explain to team personnel the risks inherent to the tasks to be performed in a controlled area.

Before taking this second session, all participants must have first completed the initial training course.

The training tools are based on the same approach as the initial module: studies of accidents or near-accidents to gain awareness of responsibilities and obligations, exercises in organizing a work site, case studies, situational exercises and group work. These different elements build awareness among participants of the different aspects of team leadership and communications.

It is important to note that these two programs never replace specific training provided for risks related to individual jobs. These risks are covered during initial professional training, as well as in "refresher" courses for each job category.

The training program calls for two "refresher" modules three years after completion of the two initial training courses.

After this training program for employees who work in controlled areas, specific training actions have been developed for distinct target populations.

1 - RADIATION PROTECTION SAFETY TEAMS AT NUCLEAR PLANTS

These training sessions last a total of four weeks. The objectives are:

- increase skills in regulatory and theoretical areas;
- enhance inter-personal relations expertise, i.e. dialogue and listening skills, problem analysis and resolution, etc.
- provide the technical skills required for detection and calculation of risks (principles for using various detectors, adjustment and calibration, qualitative and quantitative measurements), as well as knowledge of ionizing radiation (effects on materials, appropriate means of prevention).

2 - ENGINEERS ASSIGNED TO NUCLEAR PLANTS

There are two successive courses on radiation protection. The first, lasting two weeks, is for engineers who have been at a plant for at least one year and who have acquired basic knowledge of radiation protection. The second training session (four days) is a refresher course given one year after the initial session.

Both modules share a common goal: strengthen and add to understanding of the main radiation protection issues linked to normal and accident mode operation at nuclear power plants. The content covers both theory and the reasons behind rules and regulations applied.

3 - OPERATING MANAGERS

The position of operating manager was recently created in the face of two major challenges: increased safety and availability of EDF's PWR reactors, and enhanced career development of the company's managers.

The operating manager is specialized in plant operation, and has in-depth knowledge of all aspects of safety and security.

He or she is in charge of managing the operating team and is a member of the plant operating management team. A specific training program has been prepared for shift supervisors seeking to take up this new position. The program provides them with the technical knowledge required to carry out this position. Radiation protection has been identified as a central component of the course and covered both as a separate subject and indirectly through related subjects:

- generation and management of gaseous and liquid effluents and wastes;
- processing of gaseous and liquid effluents -- discharge conditions and regulatory requirements;
- "safety during accident mode operation". One of the subjects covered is the radiological consequences of incidents both at the site and off-site (magnitude of radioactive releases and dose equivalents at site boundaries for different types of accidents, criteria proposed by the International Commission on Radiological Protection, etc.);
- "radiation protection during normal operation", focusing on knowledge and control over the main risks (particularly radiological). This part of the course also covers the Alara optimization concept and containment principles.

Independent of the training programs and courses described above, radiation protection is taken into account whenever possible during training actions. For example, the SG tube break/SEPIA training tool has a simulator linked to an expert system. There is an independent system at each nuclear site (installed near the control room), available to operators at any time.

This tool simulates all types of SG tube breaks, combining in particular the initial state, unavailability of ancillary and safety systems, as well as the type of break. During the initial simulation phase, the operators manage the accident. The Sepia artificial intelligence system records operator actions and shows their impact on some one hundred different parameters. The system then analyzes the management performance of the operator during the session and generates results in learning-feedback form, acting as a trainer. One of the functions of the Sepia system is display of graphs showing changes in different parameters over time. Two of these parameters are the dose equivalent at the site boundary (500 meters), with one set of worst case scenarios and one set of realistic hypotheses.

This training policy, based on both course work and specific training, is designed to help reduce the doses recorded at nuclear sites despite the ageing of the installations.

RADIATION SAFETY TRAINING FOR URANIUM WORKERS

Bhawani Pathak

**Canadian Centre for Occupational Health and Safety
Hamilton, Ontario, Canada**

ABSTRACT

In cooperation with Denison Mines and the Atomic Energy Control Board (AECB), the Canadian Centre for Occupational Health and Safety has developed an interactive computerized radiation safety training program for uranium mine and mill workers. It consists of modules designed to provide the radiation safety training required by the Uranium and Thorium Mining Regulations (1988) of the AECB. The style and the technical level of the subject matter in these modules is appropriate for communicating scientific information to people in the "real-world" workplaces - the employers and the employees.

INTRODUCTION

Employee education and training are essential parts of any radiation protection program. The purpose of such training is to ensure that radiation workers perform their tasks in accordance with an established code of practice and in a way which poses no danger to health and safety.

The Uranium and Thorium Mining Regulations of the Canadian Atomic Energy Control Board (AECB) require that employees in uranium mines and mills receive appropriate radiation safety training. The scope of the subject matter of the training is also specified in these regulations. We developed and produced computerized training modules to fulfill the above training requirements. These modules serve two basic purposes. First, the trainer can use them as a training aid in a class room situation. Second, the trainees can use them at their own pace to review the subject matter and update themselves. In this way these modules provide the trainee an opportunity for interactive learning.

The modules were developed by the Canadian Centre for Occupational Health and Safety (CCOHS) in collaboration with the staff and Joint Health and Safety Committee at Denison Mines and the Atomic Energy Control Board.

LEARNING OBJECTIVES

The objective of this training package is to develop a heightened awareness about radiation protection among employees and enable them to take remedial action in their day-to-day work and in the event of an accident.

The modules are not intended to serve as a substitute for a trainer. Instead, they are intended to serve as a learning aid for the trainees and an instructional tool for the trainer. Movement and development of ideas and images on the screen encourage the trainees to talk about their own work situations. The trainer plays the role of an organizer and discussion leader as well as a source of technical information.

For persons with basic radiation protection training, the modules serve as a resource for self study and periodic refresher training. As well, the "Test Your Knowledge" module can be used for a quick review and self evaluation.

CONTENTS

The subject matter of this training package is designed to address the radiation safety issues of uranium miners, including the distribution of radioactive material in the mines and techniques for the evaluation and control of radiation exposure.

The training is divided into four modules which combine colourful graphics, animation and text in a comprehensive training package.

A fifth module called "Test Your Knowledge" is presented in a question and answer format. The purpose of this format is to guide the trainee through a review of the four modules.

An illustrated Glossary of technical terms is included for reference as the sixth module.

The contents of modules are outlined below.

Module I: An Introduction to Radiation

- What is radiation
- Types of radiation
- Sources of radiation
- How people are exposed
- How radiation is measured
- Harmful effects
- Exposure in mines
- Protecting ourselves

Module II: Properties and Hazards of Radiation

- Radiation emission
- The atom
- Half-life
- Types of ionizing radiation
- Radioactive dust
- Radiation exposure of uranium workers
- Lungs and dust
- What is risk

Module III: Principles of Radiation Protection

Dose limit
Minimizing external dose
Minimizing internal dose
Monitoring radiation
Workers' radiation doses
Monitoring methods
Units of measurement
Personal protective equipment
Medical surveillance

Module IV: Uranium and Thorium Mining Regulations

Uranium mining and the AECB
Regulatory control
Uranium and Thorium Mining Regulations
Joint employer-employee responsibility
Code of practice
Compliance procedures
Employer and worker obligations
Whom to contact

Module V: Test Your Knowledge

This module contains review questions on the first four modules. The questions are presented as multiple choice. When the user provides his answer, the computer displays whether or not the selected answer was correct and also displays the correct answer with appropriate illustration.

Module VI: Glossary

This module provides an illustrated definition of technical terms in a simple and non-technical language.

COMPUTER CONFIGURATION REQUIREMENTS

All the modules utilize the videotex technology based on the NAPLPS (North American Presentation Level Protocol Standard).

Equipment requirements are as follows:

- ° IBM or compatible PC, XT, 286, 386 or 486 with at least 640K RAM and either a) or b) of the following:
 - a) EGA interface card with 256K on card and an EGA colour monitor or
 - b) Norpak PCD6 or PCX6+ card and a RGB colour monitor

NEEDS FOR FUTURE DEVELOPMENT

Recent advances in computer technology enable the production of multimedia and multilingual training modules with text, sound, photo scanned images, animation and high resolution graphics.

The CCOHS plans to upgrade and convert the existing training modules for both the Macintosh and IBM platforms and standards. Work is in progress to develop radiation safety training modules specific to other selected occupational categories. These training modules will provide the user with the fundamentals necessary for working with radiation emitting equipment and radioactive materials. All these training modules will be available from CCOHS on a compact disc along with other training packages.

REFERENCES

1. Commission of the European Communities, Radiation Protection - 45. Radiation protection training and information for workers. Proceedings of a seminar held in Luxembourg, 28 to 30 November 1988. Luxembourg: Directorate General, Environment, Nuclear Safety and Civil Protection, Radiation Protection Division, 1989.
2. International Commission on Radiological Protection, Radiation Protection in Uranium Other Mines, ICRP publication 24, Annals of the ICRP Vol. 1, no. 1 (1977).
3. Atomic Energy Control Act: Uranium and Thorium Mining Regulations, Canada Gazette Part II, May 11, 1988, Ottawa: Queen's Printer for Canada, 1988.
4. International Atomic Energy Agency, Radiation Protection of Workers in the Mining and Milling of Radioactive Ores, Safety Series No. 26, 1983 Edition. Vienna: IAEA, 1983.
5. International Atomic Energy Agency, Manual on Radiological Safety in Uranium and Thorium Mines and Mills, Safety Series No. 43, Vienna: IAEA, 1975.

RADIATION PROTECTION TRAINING AT IEN/CNEN

Patricia Wieland Fajardo

Jesse James Gomes da Silva

Instituto de Engenharia Nuclear

CP 68.550 - CEP 21945 - Rio de Janeiro - BRAZIL

FAX 55/21/590-2692

ABSTRACT

Training in radiation protection is one of the most hard and important task in an occupational radiation protection program. The Radiological Protection Service of the Nuclear Engineering Institute of the Brazilian Nuclear Energy Commission (IEN/CNEN) organized several radiation protection courses suitable for research personnel, radiation workers, radiation protection specialists and non-radiation workers. All of the courses have practical exercises, simulating real situations. It has been noted the general necessity of inicial basic training on foundations of atomic and nuclear physics.

INTRODUCTION

The main activities and researches developed at the Nuclear Engineering Institute (IEN), involves the operation of an Argonaut research reactor, a CV-23 cyclotron, a radioisotope production laboratory, radiochemistry laboratories, a radwaste treatment laboratory and a type test laboratory. IEN has a staff of about 200 non-radiation workers and about 170 radiation workers. According to the activity, the associated radiological risks involve exposure to beta, gamma and neutron radiation of wide energy spectrum and external and internal contamination. From 1984 to 1990, the highest collective dose of IEN workers belongs to the cyclotron laboratory workers mainly due to the handling of the cyclotron activated parts during its maintenance⁽¹⁾.

The occupational radiation protection program consists⁽²⁾, as usual, of individual monitoring, surface, air and area monitoring, radiation protection equipment testing, decontamination and training. In order to implement this programa, the Radiological Protection Service of IEN has an infrastructure that includes a radiation measurement laboratory,

equipment testing laboratory, decontamination laboratory, laundry, radwaste provisory deposit, liquid effluent treatment installation and a staff that consists of 1 MSc, 2 physicists, a chemistry engineer and 7 technicians, all with specialization in radiation protection.

In Brazil, there are very few schools or universities that provide training in radiation protection. The courses on radiation protection at IEN are based on a standard curriculum, and depending on the worker category, relevant subjects are emphasized or included, or some subjects can be omitted. Beside the training courses, every worker receives the "IEN's Internal Regulation on Radiation Protection" that informs about responsibilities, attributions, classification of areas and operational limits.

STANDARD CURRICULUM

The basic curriculum consists of the following subjects. It is also indicated the duration of each lecture. All theoretical lecture ends with exercises and at the end of the course there is an evaluation. Those who are not successful have another chance by an oral interview. The on-the-job follow up is very important in a sense that it helps to evaluate the efficiency of the training and is a opportunity to correct any failure.

- FUNDAMENTAS OF RADIOACTIVITY (1h)
- RADIATION INTERACTION WITH MATTER (1h)
- PRINCIPLES WITH RADIATION PROTECTION (1h)
- RADIATION QUANTITIES AND UNITS (1h)
- ICRP SYSTEM OF DOSE LIMITATION (2h)
- BIOLOGICAL EFFECTS OF IRRADIATION (1h30)
- EXTERNAL RADIATION CONTROL, DOSE CALCULATION, SHIELDING DESIGN (2h)
- INTERNAL RADIATION CONTROL, ICRP MODELS, DOSE CALCULATION (2h)
- RADIATION MEASUREMENT TECHNIQUES, STATISTICS (3h)
- PRACTICE ON RADIATION MEASUREMENTS (6h)
 - AREA SURVEY WITH SEVERAL EQUIPMENTS
 - SURFACE CONTAMINATION MEASUREMENTS (FIXED AND NON-FIXED)
 - EQUIPMENT CALIBRATION
- OCCUPATIONAL RADIATION PROTECTION (1h)
- ENVIRONMENTAL RADIATION PROTECTION (1h)
- VISIT TO THE RESTRICTED AREAS OF IEN WITH ENPHASIS IN THE RADIATION PROTECTION ASPECTS OF EACH AREA (2h)

- PRACTICE ON DECONTAMINATION (1h)
- RADIOACTIVE WASTE - VISIT TO THE PROVISORY DEPOSIT (2h)
- RADIOACTIVE MATERIAL TRANSPORTATION (1h)
- RADIOLOGICAL ACCIDENTS (1h)

RADIATION PROTECTION BASICAL COURSE

The purpose of this course is to prepare technicians in charge of radiation survey and also to provide basic technical knowledge essential for those who develop activities in restricted areas. The curriculum is the standard one described above.

FOUNDATIONS OF NUCLEAR ENERGY COURSE

This course is offered by IEN for those students that must have a six month practical experience to complete the technical college. One of the subject of this course is radiation protection. The curriculum is the standard one but dose calculation and theory of radiation detection is not so deeply explored.

INTRODUCTION TO NUCLEAR ENGINEERING COURSE

This course is offered by IEN for those who have finished a technological graduation course and will begin to research in the nuclear area. One of the subject of this course is radiation protection. This subject is offered for IEN research personnel. The curriculum is the standard one without notion of radioactivity. A lecture on Optimization of Radiation Protection and an Emergency Planning are included and the exercises are mathematically more complex.

SEMINAR ON RISKS AND BENEFITS OF NUCLEAR ENERGY

This seminar is given to non-radiation workers. It is explained in a simple way what is ionizing radiation, the biological effects of irradiation, the pacific uses of nuclear energy, practical rules of radiation protection, basic emergency training and a brief description of the restricted areas of IEN. The main purpose is to divulgate de benefits of nuclear energy and avoid misunderstandings such as "the individual dosimeter is a radiation protector" or "X-ray contaminates" or

panic in case of an unusual event inside a restricted area.

1. Silva, J.J.G. and Fajardo, P.W. 1991. Occupational Radiation Exposure of the Staff of the Nuclear Engineering Institute from 1984 to 1990.
2. Fajardo, P.W., Pastura, V.F.S., Santos, I.H.T., 1991. Programas e Procedimentos em Radioproteção Ocupacional do IEN - 1991.

PRESENT SITUATION AND THE ROLE OF THE RADIATION CONTROL EDUCATION FOR HEALTH PERSONNEL BEFORE LEAVING SCHOOL

T. Orito, *S. Koga, S. Suzuki and *M. Nakamura

Department of Health Physics, School of Health Sciences, *Department of Radiology, school of Medicine, Fujita Health University, Toyoake, Japan

ABSTRACT

For purpose of investigating the present situation of radiological technologist education for radiation protection and control before leaving school, questionnaires were sent out to 28 school for radiological technologist in Japan.

For purpose of characterizing each school, it is permitted by the "Designation rules for schools and training schools for radiological technologist" to use 500 school hours for any of the subject, mainly special subjects, that are selected by the school. In investigating the 500 school hours which are left to the discretion of each school for characterization, some of these hours are used for radiation control-related subjects in 20 schools from which answers to questionnaires were obtained. Briefly, 15 to as many as 210 hours are spent for lessons regarding such subjects.

INTRODUCTION

Utilization of radiation in medical treatment has made a large contribution to society as a whole. On the contrary, radiation may bring about serious social problems not capable of being solved within the field of medicine, if used in an inappropriate manner. In this paper, the present status of radiation protection and control education for radiological technologist as health personnel before leaving school is investigated from the standpoint of the curriculums being taught and the results of a questionnaire for finding out the present situation of such education in individual schools are described.

METHOD AND DETAILS OF THE QUESTIONNAIRE

A total of 29 schools for radiological technologist exist in Japan. The students received until the year of completion are present in 28 of them. The questionnaire was sent out to the teachers in charge of radiation control in these 28 schools, with 20 of the answering the

questionnaire.

RESULTS OF THE QUESTIONNAIRE

For purpose of characterizing each school, it is permitted by the " Designation rules for schools and training schools for radiological technologist " to use 500 school hours for any of the subjects, mainly special subjects, that are selected by the school. Table 1 shows the proportion of these school hours assigned to the subjects related to radiation control. Only six of the schools had no classes in radiation control-related subjects. A varying number of school hours are assigned to these subjects in the remaining 20 schools.

Tables 2, 3 and 4 show the subjects which are also taught by teachers of radiation control, radiation health and related laws, respectively.

Table 1 Of the 500 Hours Left to the Discretion of Each School, the Following Number of Hours are Assigned as Extra Hours to Radiation Control-related Subjects.

Radiation control-related subjects are not included	Number of school
15 hours	1
21 hours	1
30 hours	5
45 hours + 120 hours (only for students who selected the subjects)	1
50 hours	1
60 hours	1
70 hours	2
120 hours	2

The teachers of radiation control-related subjects are also in charge of various other subjects as well.

DISCUSSION

As leading experts to apply radiation to the field of medical treat-

Table 2 Names of Subjects Taught by Teachers also in Charge of Other Subjects

Number of subject	Total number of teachers	Number of subject	Total number of teachers
Medical act, et. al.	7	Practice of radiation physics	1
Radiation measurement	7	Radiation physics	2
Radiochemical practice	5	Image science	1
Radiation health	3	X-ray instrument experiment	1
Radiation control experiment	2	Radiochemistry	1
Radiation measurement experiment	2	Radiation engineering	1
Nuclear medicine technology	2	Instrumental engineering	1
		Anatomy for radiography	1
		Radiobiology	1
		Radio-pharmaceuticals	1
		RI experiment	1
		Single subject	1

ment, medical radiological technicians have a much higher degree of knowledge and technological level. On the other hand, they may be

less interested in radiation protection or control, due to the fact that they are experts. If they had received fundamental education for

Table 3 Names of Subjects Taught by Teachers of Radiation Hygiene

Number of subject	Total number of teachers	Number of subject	Total number of teachers
Radiobiology	8	Radiation physics	1
Single subject	5	Biochemistry	1
Anatomy for radiography	3	Photographic technology	1
Radiation measurement	2	Experiment on measurement	1
Medical introduction	2	Special lecture on nuclear medicine technology	1
Radiation control	2	Special lecture on clinical radiation	1
		Outline of radiation medicine	1
		Radio-pharmaceuticals	1
		Radiochemical experiment	1
		Biology	1
		Mathematics	1
		English for biology	1

Table 4 Names of Subjects Taught by Teachers of Related Laws

Number of subject	Total number of teachers	Number of subject	Total number of teachers
Radiation control	7	Radiation measurement	2
Paractice of radiation control	2	Experiment on radiation photography	1
Radiation control experiment	2	Radiation physics	1
Practice of radiochemistry	2	Practice of X-ray photographic technology	1
Practice photography	2	Nuclear medicine technology	1
Radiation instrument engineering	2	Radiochemistry	1
Single subject	2	Radiobiology	1
		Radioactive drugs	1
		Radiological examination	1
		Jurisprudence	1
		X-ray photographical technology	1

radiation protection and control before they leave school, they would tion control, radiation health and related laws directly related to them were investigated from the standpoint of curriculums by means of carrying out a questionnaire in the present study. In investigating the 500 school hours which are left to the discretion of each school for characterization, some of these hours are used for radiation control-related subjects in 20 schools from which answers to questionnaires were obtained. Briefly, 15 to as many as 210 hours are spent for lessons regarding such subjects. These results suggest that radiation protection and control are considered very important by teachers actively engaged in the education of students who want to be radiological technologist. Radiation protection and control are expressed more clearly in curriculums for radiological technologist than for any of the other kinds of medical professionals. Moreover, many hours are used to lecture on these subjects. It is conceivable

from these findings that the role of radiological technologist in radiation protection and control is one of their most important tasks. To our surprise, however, the lessons on radiation control, radiation health and related laws are given by teachers who are also in charge of other subjects. The absence of true professionals may be seen by the fact that lessons on radiation control-related subjects are given by teachers who are in charge of a wide range of subjects. Taken altogether, it must be said that the content of education for radiation protection and control is seriously lacking, though these subjects are deemed important in the education of students who want to be radiological technologist. Accordingly, it may also be an urgent necessity to bring up the level of teachers specializing in subjects related to radiation protection and control. Taking this need into consideration, education for radiological technologist must be conducted not only in training schools and junior colleges but also at the university level as well. It is necessary to actively introduce these subjects into university education and to develop a system of radiation protection and control.

CONCLUSIONS

For purpose of investigating the present situation of radiological technologist education for radiation protection and control before leaving school, questionnaires were sent out 28 schools for radiological technologist. Based on the answers obtained from 20 of them, the following conclusions were able to be obtained.

(1) Of the 500 school hours left to the discretion of each school, 15 to 120 hours are assigned to radiation control-related subjects in 14 of the 20 schools.

(2) Since many teachers are in charge of classes of radiation control, radiation health and radiation-related laws as well as other classes, it is necessary to increase the number of teachers who are actually specializing in radiation control-related subjects.

(3) The range of related laws actually taught is wider than prescribed in the designation rules.

REFERENCE

1) Ministry of Education and Ministry of Health and Welfare: Enforcement of ordinances for partial revising of the designation rules for schools and training schools for medical radiological and X-ray technicians (1981).

EDUCATIONAL PROGRAMME ON RADIATION PROTECTION FOR
VETERINARY MEDICINE SPECIALISTS

G. Djuric and D. Popovic

Department of Radiology and Radiation Hygiene and Department
of Physics, School of Veterinary Medicine, Belgrade,
Yugoslavia

ABSTRACT

The education of radiation protection for veterinary medicine specialists on the University of Belgrade is integrated both in regular graduate studies and in postgraduate studies. Within the graduate studies, students attend courses in physics and biophysics and in radiation hygiene. During postgraduate or specialistic veterinary medicine studies, veterinary medicine specialists expand their knowledge in radiation protection through a number of courses on radiation biophysics, radioecology, nuclear instrumentation and environmental protection.

INTRODUCTION

Radioactive contamination of the environment became a very serious problem during the age of nuclear energy exploitation. As the radiocontamination of the biosphere includes the contamination of the cattle breeding process and the live stock production and eventually the man exposure to radiation through food, the radiation hygiene in animal and food production was developed as a new educational and scientific discipline in veterinary medicine. Together with radiation protection it obtained an important role both from medical and technological point of view, in scientific as well as in practical sense, in the field of activity of a modern veterinary medicine specialist. The knowledge that such a specialist should obtain through these courses, together with basic knowledge in physics, is intended to enable him to undertake necessary measures of radioprotection and radio-decontamination if the radioactive contamination endangers the animal or food production process. The nuclear accident in Chernobyl and the situation that followed, confirmed that this matter is of invaluable importance for veterinary medicine specialists, especially those involved in the inspection of cattle and food production.

EDUCATIONAL PROGRAMME ON RADIATION PROTECTION IN THE GRADUATE STUDIES

During the first year of veterinary medicine studies, students obtain basic elements of radiation biophysics through courses of elementary physics and biophysics. The educational programme is carried out within a course of 2 theoretical lessons and 2 laboratory lessons per week during 15 weeks. The programme comprises:

- atom and nuclei structure, nuclei forces and bond energy;
- stable and unstable nuclei, radioactive disintegration and the law of radioactive decay;
- emission of alpha and beta particles and gamma and neutron rays and their interaction with matter;
- nuclear reaction, production and properties of radioisotopes, their application in medicine and biology;
- ionizing radiation: sources, detection and dosimetry, biological effects.

Laboratory lessons comprise detection of radioactive radiation and its absorption in matter with Geiger-Muller nuclear instrumentation, as well as calculation exercises on the matter.

Within the fifth year of veterinary medicine graduate studies, students attend a course on radiation hygiene including 15 lectures and 30 laboratory exercise hours. The programme comprises basic elements of radiation hygiene in animal production and food technology, including:

- basic principles of radioecology in animal production;
- distribution of natural and technologically produced radionuclides in different phases of cattle breeding process and food chains;
- internal radiocontamination of animals;
- radiopathology: radiation sickness in animals, methods of internal and external radiodecontamination;
- basic principles of radiation protection: units, standards, recommendations, permissible doses for occupational and nonoccupational exposures, accidental doses;
- radiohygienic control of food and fodder;
- nuclear accidents and protective measures in animal and food production;
- exposure and radiation risk for agricultural workers in accidental situations due to radiocontamination of the environment.

The laboratory exercises are especially emphasized within the framework of the course; students are acquainted with some of the methods for fast evaluation of radionuclide contents in food and fodder. The methods are developed for radiometric laboratories with GM counter detector. The exercises include detection of ionizing radiation and absorption of beta and gamma radiation in different materials, exposure

rates measurements in the field, mass activity determination of food and fodder including sampling, transport and storage procedures, fast evaluation of radionuclides contents in food and fodder in accidental situations, undertaking of protective measures and recommendations in food and fodder usage in accidental situations.

EDUCATIONAL PROGRAMME ON RADIATION PROTECTION IN POST-GRADUATE STUDIES

During postgraduate or specialistic veterinary medicine studies, veterinary medicine specialists expand their knowledge on radiation protection through a number of courses on biophysics, radioecology, nuclear instrumentation and environmental protection. The programmes discuss biophysical, radiobiological and biomedical aspects of the effects of ionizing radiation on cellular and molecular level, as well as some aspects of radiation diseases and post irradiation recovery.

The special course on environmental radiation protection considers:

- sources of ionizing radiation in the environment,
- translocation of radionuclides from the source of radiocontamination to man;
- radioecological parameters, concentrations, translocation and discrimination factors;
- models of radionuclides migration in the biosphere;
- instrumentation and methods for radionuclides detection and identification in the environment;
- aspects of dose and risk evaluation for animal and food production and eventually, population on the whole.

Some of the courses are specially organized for veterinarian inspectors. They provide important informations about legal regulatives in production of animal and food regarding radioactive contamination, especially in accidental situations. There are also training courses in methodology of fast evaluation of radioactive contamination of food and fodder in the field.

CONCLUSIONS

In the field of activity of a modern veterinary medicine specialist radiation protection plays an important role, both from medical and from technological point of view. The possibility of occurrence of large nuclear accidents demands that one obtains basic theoretical knowledge in radiation physics and biophysics, as well as to be acquainted with methods of detection of radionuclides in the environment, methods of radiodecontamination of animals and food and legal regulatives in this area. Radiation protection should be therefore considered an integral part of the educational

process in graduate and in postgraduate studies of veterinary medicine.

REFERENCES

1. Draganovic B., Djuric G., Petrovic B. and Zagorcic A., 1980, Radiation Biology, University Press, Beograd.
2. Djuric G. and Petrovic B., 1982, Nuclear Instrumentation and Methods in Radiometry, University Press, Beograd.
3. Djuric G., 1985, Laboratory Training Course in Radiation Hygiene, University Press, Beograd.
4. Djuric G., 1985, A Notebook for Laboratory Training Course in Radiation Hygiene, University Press, Beograd.
5. Petrovic B. and Djuric G., 1981, Elements of Radioecology in Animal Production, University Press, Beograd.
6. Petrovic B., Djuric G. and Draganovic B., 1984, Radiation Hygiene in Animal Production, University Press, Beograd.
7. Popovic D. and Stefancic V., 1984, Laboratory Training in Physics and Biophysics, University Press, Beograd.
8. Popovic D. and Stefancic V., 1988, Courses in Physics and Biophysics, University Press, Beograd.

DEVELOPMENT OF AN EFFECTIVE DOSE EQUIVALENT DETECTOR
HAVING ANGULAR RESPONSE OF HUMAN BODIES

M.Tsutsumi, K.Saito and S.Moriuchi

Department of Environmental Safety Research,
Japan Atomic Energy Research Institute,
Tokai-mura, Ibaraki-ken, Japan

ABSTRACT

In order to estimate effective dose equivalent due to external photon exposures, a new shape of NaI(Tl) scintillation detector was developed which has an angular response similar to that of adult human bodies. Further, the detector utilized a spectrum-dose conversion function for compensating accurately the difference of energy response. The accomplishment of this detector made it possible to estimate effective dose equivalent easily from direct measurement without assuming irradiation conditions.

INTRODUCTION

ICRP ¹⁾ introduced effective dose equivalent (H_E), being a better indicator of stochastic effect of radiation, for radiation protection. In practice, quantities proposed by ICRU such as $H^*(10)$ have been used since they give conservative values for H_E under arbitrary exposure conditions. In case H_E is estimated, conversion factors assuming an irradiation condition have been multiplied to a measurable quantity. One of the reasons why such indirect procedures have been taken is the difficulty of acquiring the information of irradiation condition, that is, the angular distribution of incident radiations on human bodies. This information is needed because human body's sensitivity depends strongly on the incident angle of radiation.

This study intended to develop a detector which has responses similar to human body. In order to meet this requirement, we used the following two methods in this study: (1) letting the detector have the angular sensitivity similar to human bodies, for the irradiation geometry problem; (2) making the energy weighting $G(E)$ function applied to this detector for the compensation of energy response.

DETECTOR

The scintillation detector which incorporates 75 mm in diameter x 210 mm long NaI(Tl) crystal was constructed. The shape is circular cylindrical with the both ends spherically cut, as shown in Photo 1. The shape and size were determined from empirical estimate of

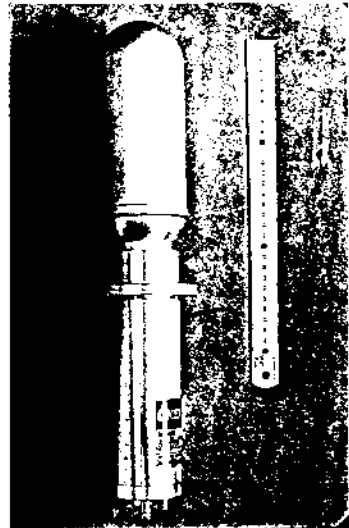

Photo 1 Effective dose equivalent detector.

change of absorbed energy in the crystal due to the incident angle. The sensitivity difference around the body axis, which is not significant under usual exposure conditions, is not considered.

On the characteristics on angular sensitivity, we compared H_E with this detector at 3 points of energies, 124 keV, 514 keV and 1836 keV. The comparisons are shown in Fig. 2(a)-(c). Both are in good agreement except for the direction of photomultiplier tube. Judging from the solid angle extended by the photomultiplier tube, the effect of the difference is considered not significant. Both curves coincide within 10% except for this direction.

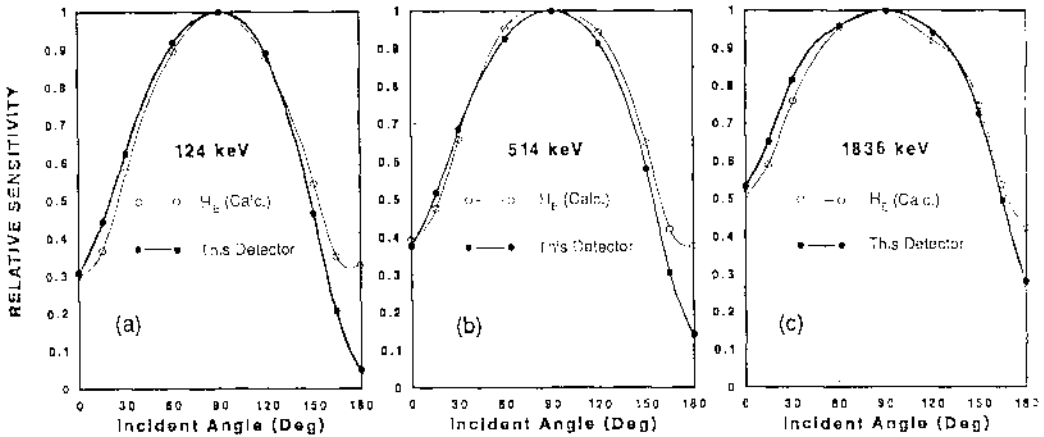

Fig.2 Comparison of angular sensitivities of this detector to H_E . Energies are (a) 124 keV, (b) 514 keV and (c) 1836 keV. Head: 0 Degree.

The effect of detector dimensions was discussed from detector responses calculated with the Monte Carlo code MARTHA. The results from this simulation are shown in Fig.3. Here, the ratio of detector response to gamma rays coming from 0 deg. direction over that to gamma rays from 90 deg. direction was considered. The axis of ordinates represents the relative deviation of the ratios between the detector and human bodies, the axis of abscissas the ratio of the length to the diameter of detector. At low energy the angular profile of the detector is mainly deter-

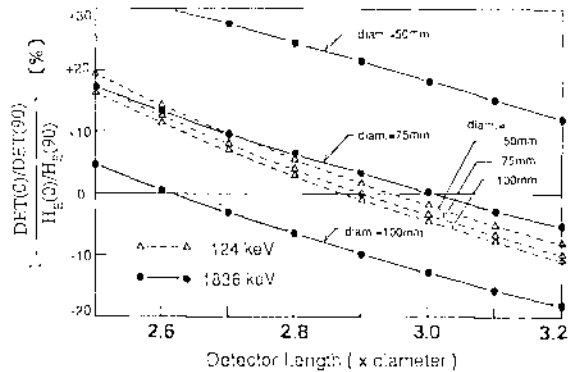

Fig.3 Relationship between detector dimensions and angular sensitivity. $DET(x)$: Detector sensitivity at angle x. $H_E(x)$: H_E at angle x.

mined by the ratio of the length to the diameter. The higher the energy is getting, the more critical the diameter becomes. It is desirable that the zero crossing point on this figure does not change much for a wide range of energy. From this view point, the optimum diameter should preferably be about 80 mm, the optimum length being about 2.8 to 3.0 times the diameter of the detector. From this figure, the dimensions of the detector constructed were confirmed to be fairly close to the optimum ones.

G(E) FUNCTION

A spectrum-dose conversion function ²⁾ called "G(E) function" is defined by the following equation,

$$\int_{E_{\min}}^{E_{\max}} F(E, E_j) \cdot G(E) dE = D(E_j)$$

where $F(E, E_j)$ and $D(E_j)$ are a measured pulse-height spectrum and an interested dose quantity due to a certain number of photons with energy E_j , E_{\min} and E_{\max} being lower and upper energy limits. Here, E_{\min} and E_{\max} were taken to be 40 keV and 10 MeV, respectively. The $G(E)$ function is usually determined by polynomial fitting from several tens of $F(E, E_j)$ and the corresponding $D(E_j)$ covering energies considered.

Response functions $F(E, E_j)$ were calculated by MARTHA. Here, the $G(E)$ function was determined for planar isotropic irradiation, and the $D(E_j)$ are taken from data of GSF ^{3,4)}, which present the H_E per unit fluence as a function of photon energy. These factors have been derived from calculations using a Monte Carlo computer code and associated anthropomorphic phantoms. The $G(E)$ function can calculate doses within 2% over the whole energies. $G(E)$ values are expressed in $\text{nSv} \cdot \text{h}^{-1} / \text{cpm}$.

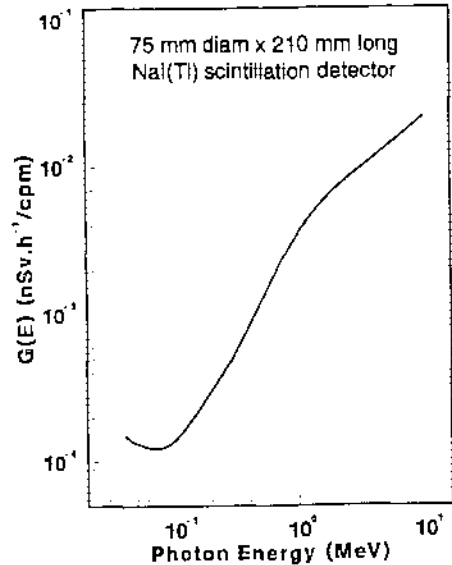

Fig.4 G(E) function applied for this detector.

APPLICATION IN NATURAL ENVIRONMENT

Applying this detector to natural gamma rays, we examined variability of conversion coefficients from air dose to H_E in Sv per Gy. Generally, a constant of 0.7 ⁵⁾ is used as this conversion coefficient. Furthermore, H_E may also depend on the posture of the body. Measurements were performed at indoors and outdoors, changing the orientation of detector to simulate body postures; standing (detector axis = 0 deg) and lying (axis = 90 deg). Air dose (free-in-air) measured by a 3 in. diam. spherical NaI(Tl) detector was used as a normalizing quantity. Obtained results are shown in Table 1. The results are a

little higher than the conventional value 0.7. However, these are in good agreement with our former results^{6,7)}. It was observed that the conversion coefficients do not depend much on human posture for natural radiation.

CONCLUSIONS

The method introduced in this paper made it possible to estimate H_E easily from direct output of the detector without assuming angular and energy distributions of incident photons. Angular responses of the developed detector are in good agreement with H_E , and errors induced from dose conversion using $G(E)$ function is very small. Consequently, overall systematic errors are within 10%, up to 2 MeV except for its particular incoming angle. Moreover, the posture of the body exposed, for example, standing or lying, is able to be easily accounted by changing the orientation of the detector.

It is believed that the H_E detector is a useful device to estimate H_E for radiation workers as well as for the public in the environment.

REFERENCES

1. ICRP, 1977, Recommendations of the ICRP, ICRP Publication 26, Pergamon Press, Oxford.
2. Moriuchi, S., 1971, A New Method of Dose Evaluation by Spectrum-Dose Conversion Operator and Determination of the Operator, JAERI 1209 (in Japanese).
3. Williams, G., Zankl, M., Eckerl, H. and Drexler, G., 1985, The Calculation of Dose from External Photon Exposures Using Reference Human Phantoms and Monte Carlo Methods - Part 2: Organ Doses from Occupational Exposures, GSF-Bericht S-1079.
4. ICRP, 1987, Data for Use in Protection against External Radiation, ICRP Publication 51, Pergamon Press, Oxford.
5. UNSCEAR, 1988, Sources, Effects and Risks of Ionizing Radiation, United Nations.
6. Moriuchi, S., Tsutsumi, M. and Saito, K., 1990, Examination on Conversion Factors to Estimate Effective Dose Equivalent from Absorbed Dose in Air for Natural Gamma Radiations, Hoken Butsuri, 25, pp.121-128 (in Japanese).
7. Saito, K., Petoussi, N., Zankl, M., Veit, R. and Drexler, G., 1990, Calculation of Organ Doses from Environmental Gamma Rays Using Human Phantoms and Monte Carlo Methods - Part 1: Monoenergetic Sources and Natural Radionuclides in the Ground, GSF-Bericht 2/90.

Table 1 Variability of conversion coefficients, Sv/Gy in natural circumstances.

Places	Sv/Gy	
	(Standing)	(Lying)
Indoors	0.73 - 0.77	0.73 - 0.79
Outdoors	0.72 - 0.74	0.73 - 0.79

ETUDE D'UNE SOURCE DE RAYONNEMENT SIMULANT DES SPECTRES
REALISTES DE NEUTRONS POUR L'ETALONNAGE D'APPAREILS DE
RADIOPROTECTION

J.L. CHARTIER - F. POSNY - M. BUXEROLLE
CEA/Institut de Protection et de Sûreté Nucléaire
Département de Protection de la santé de l'Homme et de
Dosimétrie - Ministère de l'Industrie

STUDY OF A RADIATION SOURCE FOR THE SIMULATION OF REALISTIC
NEUTRON SPECTRA FOR CALIBRATING

A set-up intended to replicate neutron spectra encountered at workplaces is presented. Such a facility can provide means of calibrating dosimeters in spectral conditions similar to those of their use for radiation protection purposes. Results of a computational approach are compared with Bonner Multisphere Spectrometer measurements.

I - INTRODUCTION -

La simulation de spectres neutroniques réalistes constitue, actuellement, l'un des domaines d'étude de la radioprotection. Son but principal, est d'obtenir, avec l'instrumentation en usage, une meilleure estimation des doses "neutron" auxquelles sont soumis les personnels en activité dans l'industrie nucléaire. L'importance de ce projet, déjà reconnue en raison des performances limitées des dosimètres de surveillances individuelle et d'environnement, s'est amplifiée avec la publication des Nouvelles Recommandations de la CIPR (Rapport 60) en raison de l'abaissement des limites primaires de doses et du changement des facteurs de qualité des neutrons.

Pour l'étalonnage des instruments, la panoplie des spectres de référence recommandés est assez pauvre (4 spectres disponibles) et leur représentativité ne fait pas l'unanimité, par exemple : réacteurs, conteneurs de transport.

Il s'avère donc indispensable de compléter les moyens d'étalonnage actuels par d'autres dispositifs, mieux adaptés, délivrant des spectres neutroniques plus variés, dont la conformité aux situations effectivement rencontrées soit établie. Ceci a justifié l'action conjointe de plusieurs laboratoires dans le cadre du contrat CCE Bi7-0031-C, afin de recenser ces situations réelles, puis de les simuler en laboratoire.

Le principe d'un montage expérimental a été défini et ses caractéristiques ont été calculées puis optimisées à l'aide du code MCNP.

II - PRINCIPE DU MONTAGE -

II.1 - Généralités sur les spectres neutroniques réalistes

Une description générale simple représente de façon satisfaisante l'ensemble des cas rencontrés en radioprotection. 3 zones énergétiques composent un spectre réaliste (1,2) :

- a) la zone "thermique" (TH) : $E_n < 1 \text{ eV}$
- b) la zone "intermédiaire" (INT) : $1 \text{ eV} < E_n < 10 \text{ keV}$
- c) la zone "haute énergie" (HE) : $10 \text{ keV} < E_n < 15 \text{ MeV}$

Les données consultées résultent, en général, de mesures multisphères (ou sphères de Bonner) pour lesquelles les informations spectrométriques doivent être considérées avec précaution (3).

Les différents "spectres" étudiés, ont montré que :

- a) les contributions relatives en fluence dans les zones TH, INT et HE peuvent varier dans de larges proportions,
- b) pour la zone HE, l'énergie moyenne de la distribution constitue un paramètre supplémentaire dépendant :

Pour la radioprotection, la loi de variation avec l'énergie de $h_\phi(E)$, facteur de conversion fluence-équivalent de dose, modifie notablement les "poids" dosimétriques respectifs des différentes zones.

II.2 - Éléments fondamentaux de montage -

Le concept choisi est celui d'un dispositif de laboratoire produisant un faisceau de rayonnement non perturbé par l'environnement (Fig. 1).

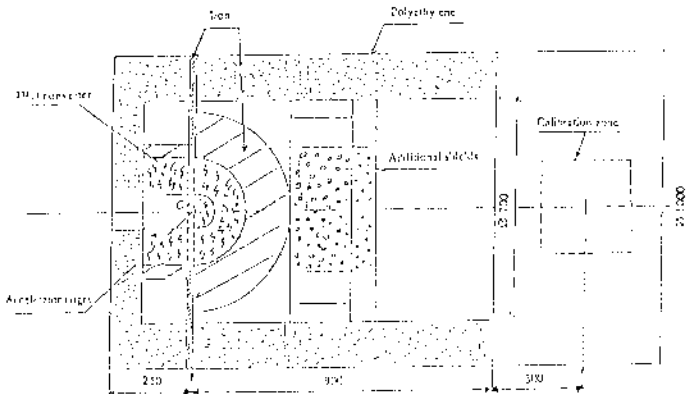

Figure 1

Schématiquement, les parties principales de l'option choisie sont :

- une source de rayonnement, constituée d'un convertisseur d' ^{238}U irradié en son centre par la cible d'un accélérateur,
- une chambre de diffusion, associant un canal cylindrique en polyéthylène et des écrans complémentaires,
- une zone d'étalonnage, assimilée à un orthocylindre ($h = \varnothing = 30$ cm), situé à 30 cm du plan de sortie du canal de $(\text{CH}_2)_n$.

L'étude des spectres neutronique et photonique, produits dans la zone d'étalonnage, a été effectuée à l'aide du code MCNP-3A, pour 2 énergies de la source primaire :

* Configuration (I) : $E_n^1 = 14,6$ MeV [Réaction (d,T)]

* Configuration (II) : $E_n^2 = 2,8$ MeV [Réaction (d,d)]

L'homogénéité de la fluence dans la zone d'étalonnage a été vérifiée aux distances 5, 10 et 15 cm de l'axe. Les variations relatives sont $< 2\%$ pour l'ensemble des cas étudiés.

III - ETUDE DE LA CONFIGURATION (I) : $E_n^1 = 14,6$ MeV -

III.1 - Atténuation de la composante "neutron" parasite de 14,6 MeV -

Afin de réduire cette contribution, une coquille de fer de 15 cm d'épaisseur entoure le convertisseur, et une 1/2 sphère d' ^{238}U , de rayon 5 cm, est placée au contact de la cible. Dans ces conditions, la contribution parasite résiduelle est :

- en fluence $\Phi_{14,6}/\Phi_{total} \approx 0,2\%$
- en équivalent de dose $H_{14,6}/H_{total} \approx 1,7\%$

La géométrie de base du système est représentée par $[E_n^1 + U + Fe]$.

III.2 - Caractéristiques des spectres produits -

Quelques exemples de spectres calculés pour le dispositif expérimental considéré sont tracés sur la figure 2 et regroupés dans le tableau 1.

TABLEAU 1

CONFIGURATION (I) - $E_n^1 = 14,6$ MeV										
Numero du spectre	Caractéristiques du montage	θ_m (%)	θ_{av} (%)	θ_{ca} (%)	E_1 (MeV)	θ_{1m} (%)	θ_{1av} (%)	θ_{1ca} (%)	E_1^1 (MeV)	Débit d'équivalent de dose moyen ($\mu Sv/h$)
I	$[E_n^1 + U + Fe]$ sans canal	0	1	99	0,42	0	0	100	0,71	2850
II	$[E_n^1 + U + Fe]$ + canal (13) θ_{1ca} $l = 90$ cm	36	20	44	0,15	6	3	91	0,61	1700
III	$[E_n^1 + U + Fe]$ + canal (13) θ_{1ca} $l = 90$ cm	21	18	61	0,13	2	2	96	0,63	1000
IV	$[E_n^1 + U + Fe]$ + canal (13) θ_{1ca} $l = 90$ cm + Fe de 10 cm	45	27	28	0,08	12	7	81	0,50	1700
V	$[E_n^1 + U + Fe]$ + canal (13) θ_{1ca} $l = 90$ cm + Fe de 10 cm	10	28	42	0,14	5	1	90	0,62	1500
VI	$[E_n^1 + U + Fe]$ $l = 90$ cm + (13) θ_{1ca} + Fe de 10 cm	41	26	31	0,09	10	7	83	0,56	2100

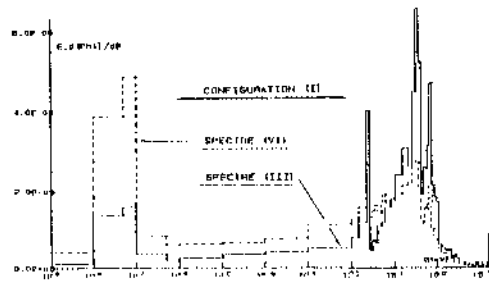

IV - ETUDE DE LA CONFIGURATION (II) - $E_n^2 = 2,8$ MeV -

Le même dispositif expérimental de diffusion peut aussi être associé à une source de neutrons de 2,8 MeV produits par réaction (d,d). Dans ce cas, la composante monocinétique transmise appartient au domaine "haute énergie" du spectre. La géométrie de base du système est donc : $[E_n^2 + U]$.

Quelques résultats des calculs sont rassemblés dans le tableau 2 et tracés dans la figure 3.

TABLEAU 2

CONFIGURATION (II) - $E_n^2 = 2,8$ MeV										
Numero du spectre	Caractéristiques du montage	θ_m (%)	θ_{av} (%)	θ_{ca} (%)	E_1 (MeV)	θ_{1m} (%)	θ_{1av} (%)	θ_{1ca} (%)	E_1^1 (MeV)	Débit d'équivalent de dose moyen ($\mu Sv/h$)
A	$[E_n^2 + U]$ sans canal	0	0	100	0,71	0	0	100	1,05	420
B	$[E_n^2 + U]$ + canal (13) θ_{1ca} $l = 90$ cm	37	17	46	0,24	4	3	91	0,83	600
C	$[E_n^2 + U]$ + canal (13) θ_{1ca} $l = 90$ cm + (13) θ_{1ca} $l = 90$ cm	36	16	48	0,19	4	2	94	0,96	600
D	$[E_n^2 + U]$ + canal (13) θ_{1ca} $l = 90$ cm + (13) θ_{1ca} $l = 90$ cm	23	15	60	0,16	2	1	97	1,00	510

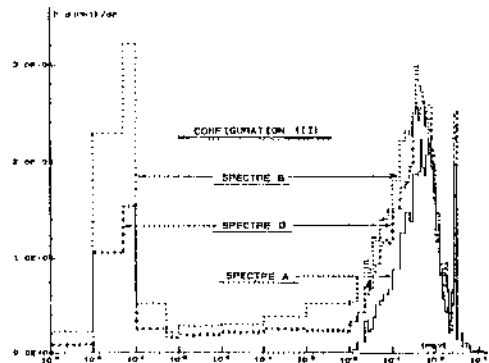

V - COMMENTAIRES SUR LES SPECTRES NEUTRONIQUES CALCULES -

Les résultats présentés ont pour objectif principal de traiter des situations courantes de l'industrie nucléaire où les protections biologiques et l'environnement contribuent à produire des spectres dégradés : conteneurs de transport, laboratoires de fabrication de combustibles...

A partir de ces résultats, on constate que 2 groupes de spectres neutroniques de basse énergie peuvent être produits à l'aide de ce montage : $\bar{E}_1 \approx [0,10 \text{ à } 0,20] \text{ MeV}$ et $\bar{E}_2 \approx [0,25 \text{ à } 0,35] \text{ MeV}$.

Deux exemples de simulation sont présentés ci-dessous. Ils correspondent, d'une part, au spectre de fuite d'un conteneur LK100 de transport de combustibles (spectre 28, réf. 1), et d'autre part, à une zone de passage dans un laboratoire de retraitement de combustibles (spectre E, réf. 2).

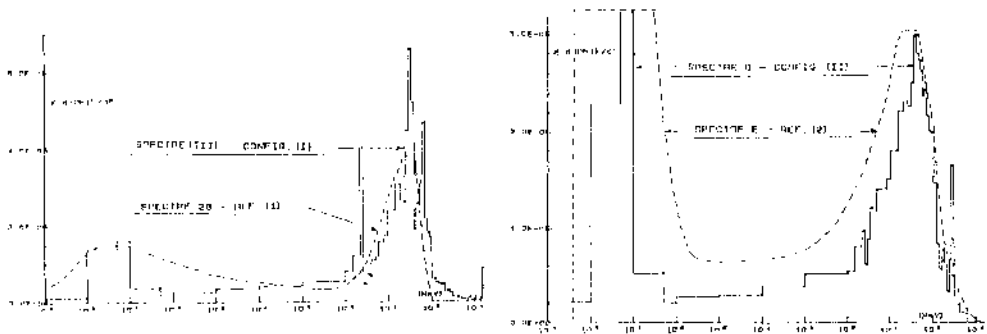

VIII - CONCLUSIONS -

Un dispositif d'irradiation destiné à reproduire dans un laboratoire d'étalonnage des spectres neutroniques réalistes rencontrés en radioprotection a été présenté. A l'aide du code MCNP, les caractéristiques de plusieurs spectres disponibles dans la zone d'étalonnage ont été calculées. Enfin, le domaine d'application de ce dispositif a été précisé par le biais de comparaison à des données expérimentales.

BIBLIOGRAPHIE

- 1 - M. BUXEROLLE et al. Catalogue de spectres de neutrons. Rapport CEA-R-5398 (1987).
- 2 - J.C. LIU et al. Neutron spectra measurements at ORNL. Rad. Prot. Dos., Vol. 30, N°3, p. 169-178 (1990).
- 3 - A.V. ALEVRA et al. Unfolding Bonner-sphere Data : A European Intercomparison of Computer Codes - PTB-7.22-90-1 (Januar 1990).
- 4 - K. KNAUF et al. Neutronen spektrometrie in Strahlenschutz PTB Mitteilungen 99 (Februar 1989).
- 5 - J.F. BRIESEMESTER et al. MCNP - A General Monte Carlo Code for Neutron and Photon Transport (Version 3A) - LA-7396-M, Rev. 2 (Sept. 1986).

A RADON EXPOSURE CHAMBER IN HONG KONG

John K.C. Leung, D. Jia and Man-yin W. Tso

Radioisotope Unit,
University of Hong Kong,
Hong Kong.

ABSTRACT

A radon exposure chamber was constructed. Both ^{222}Rn and ^{220}Rn can be injected independently or simultaneously into the chamber from separate dry sources. The air flow in the chamber can be adjusted manually in a 100% flow-through mode, 100% recirculate mode or flow-through/recirculate mode. Water vapour and aerosol particles of variable sizes are injected into the chamber through computer controlled mechanism. The continuous radon and radon progeny concentration and working level, and aerosol concentration are constantly monitored by the microcomputer.

INTRODUCTION

The Radioisotope Unit (RIU) of the University of Hong Kong has had a programme of research on radon and its decay products started a number of years ago. Surveys on radon concentration and working levels have been conducted which indicated that the arithmetic means of both indoor radon concentration¹ and working level² are higher than most other countries and the world average³.

Because of the special geological conditions and tropical monsoon climate, Hong Kong deserves special attention to the adaptability and response of radon detectors which were otherwise proved to be good in Continental or high latitude countries. With the experience gained and quality of measurements assured through participating in the Asian/Australasian Regional Intercomparison Programme in 1987/88⁴ and a similar programme in China in 1989, the RIU has successfully constructed a radon exposure chamber which is essential for calibrating radon and radon progeny measuring instruments over a range of temperature, humidity and aerosol concentration likely to be experienced in this region of the world. In addition to calibrating instrument and detectors, the chamber will also provide service for interlaboratory comparison studies (one such programme is being conducted during the writing of this paper), and for other research and development projects.

THE RADON EXPOSURE CHAMBER

A schematic diagram of the exposure chamber is shown in Fig. 1. The chamber is made of stainless steel and has a volume of 1.4 m^3 ($1.3\text{m} \times 1.2\text{m} \times 0.9\text{m}$). A smaller conditioning chamber having a volume of 0.056 m^3 is attached to the side of the main chamber. Radon gas, recirculated gas, water vapour and aerosols are injected into the conditioning chamber where they are mixed before being passed into the main chamber. The gas diffuses into the main chamber through a series of perforated tubing laid at

the bottom of the chamber to ensure an even mixture. The air flow in the chamber can be adjusted manually in a flow-through, recirculate or flow-through/recirculate mode so that a wide range of environmental condition can be simulated. The maximum air exchange rate (including recirculated air through the conditioning chamber) is about 1 hr^{-1} . The various flow modes are illustrated in Fig. 2.

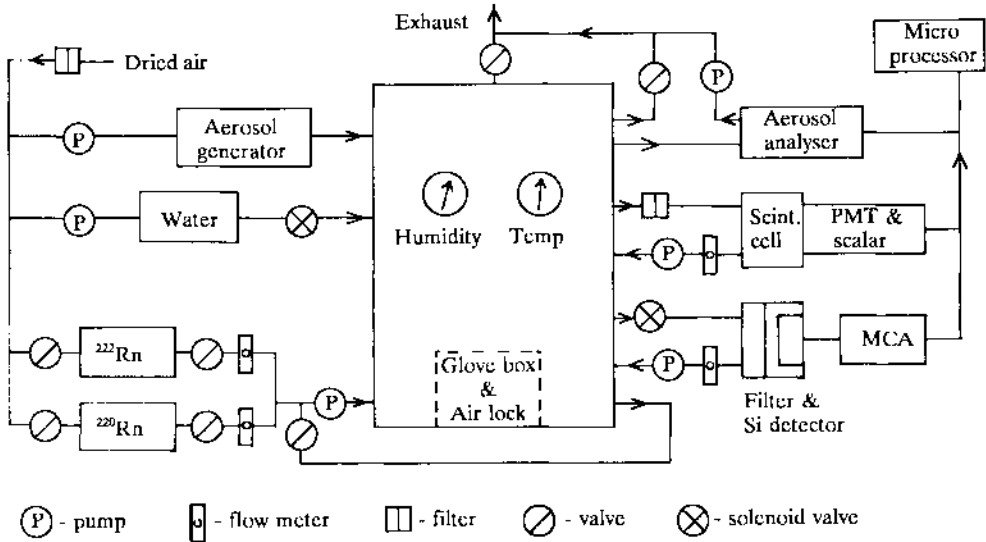

Fig. 1 Schematic diagram of the radon exposure chamber

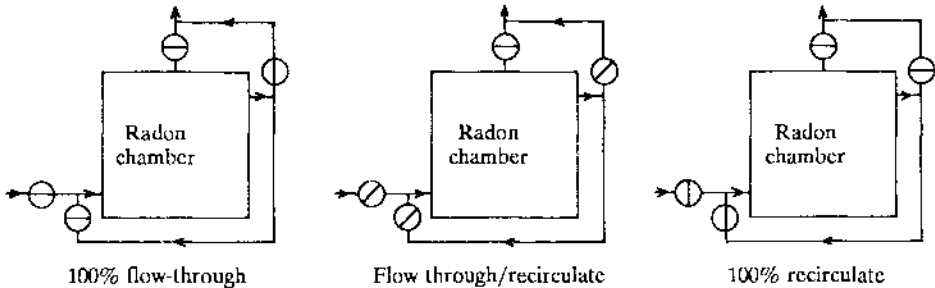

Fig. 2 The air flow mode of the radon chamber

The chamber is totally heat insulated from the surrounding by 1/2 inch foam insulator which allow it to operate in a temperature other than room temperature. On the front of the chamber is a viewing glass which can be opened for putting large equipment into the chamber. Smaller piece of equipment can pass through an airlock at the side of the chamber without having to shut down the system completely. A pair of long armed glove is provided for easy access of the inside of the chamber. The following is a brief description of the peripheral equipment installed to the chamber.

1. Radon source. Flow through type dry source of ^{222}Rn and ^{220}Rn (RN1025 and TH1025, Pylon Electronic Development Co., Canada) of various activity are used to provide a wide range of radon concentration. Dry and filtered air carries the radon gas and is mixed with the recirculated gas before being pumped into the conditioning chamber. The radon concentration inside the chamber depends on the source strength and the circulation mode. The nominal range is from a few hundred Bq m^{-3} to 10^5Bq m^{-3} . It is to be noted that the flow rate through the radon source becomes critical when the chamber is operating at low concentration under a 100% flow through mode.

2. Aerosol generator. To maintain a steady aerosol size and concentration, a high output atomizer (Model 3076, TSI Inc, USA) together with a diffusion dryer (Model 3062, TSI) is installed. The aerosol particle size can be altered by changing the amount of solute in the solution. Typical particle size is from $0.02 \mu\text{m}$ to $0.3 \mu\text{m}$. The pump for the atomizer is computer controlled to turn on and off intermittently. By adjusting the ejection duration and interval, a wide range of aerosol concentration can be achieved.

3. Water source. Water is sprayed into the conditioning chamber through pressure exerted to a reservoir of water by a pump. The pump and the solenoid valve which gates the water pathway are controlled by the computer to maintain the desired humidity.

4. Temperature control. A simple heating coil inside the conditioning chamber is used to warm the chamber gas to above room temperature. For low temperature, the gas is circulated through a freezer by a coil of copper tubing outside the chamber. By using the heater and freezer independently or simultaneously, a temperature range of about 0°C to 60°C can be achieved.

5. Radon gas measurement. The gas inside the chamber is continuously pumped through a scintillation cell connected to a photomultiplier tube and a counter. The radon daughters are first removed by a filter and the radon gas that decays inside the scintillation cell is recorded. The continuous radon concentration is then calculated by an algorithm which takes into account of activities of previously deposited radon daughters and also corrects for different humidities and flow rates.

6. Radon daughter measurement. The radon daughters are sampled intermittently by a filter and Si α -detector assembly. The complete α spectrum of the radon daughters collected in the filter paper can be recorded in a computer controlled multichannel analyzer (PCA-II, Tennelec Inc, USA). Alternatively, three count method, five count method or similar algorithm are also being used to determine the daughter activities and working levels. The gas flow through the filter is governed by a solenoid valve and a pump which are again controlled by the computer.

7. Aerosol measurement. A condensation nuclei counter (Model 3760, TSI) is used to count the aerosol concentration. A variable number of stainless steel wire screens can be added to

the front of the analyzer to discriminate the size of aerosol particles inside the chamber. The analyzer will be operated intermittently and the data can be communicated to the computer. A maximum of 2.5×10^4 particle per cc can be measured.

AN INTERCOMPARISON PROGRAMME

Despite of the small area of Hong Kong, at least five organisations (higher institutions including RIU and Government Departments) are doing investigations on radon in one way or the other. It is noted that a wide range of detectors are being used by different organisations. Most of them were commercially bought and therefore the calibration factors rely solely on the manufacturers. Because of the lack of locally available calibration standards, some inconsistency has already been observed among detectors owned by different organisations. As the best equipped and experienced laboratory in Hong Kong on the radon issue, the RIU of the University of Hong Kong is conducting a territory radon intercomparison programme with this newly built radon exposure chamber. The result of the programme will be reported in due course. Hopefully, the exercise will assure the quality of measurement done by all the participating organisations.

CONCLUSION

A radon exposure chamber has been built which can be operated at various simulated environmental conditions. Studies on ^{222}Rn , ^{220}Rn or a mixture of them can be done precisely. Calibration of detectors and some form of intercomparison are other applications of the chamber.

REFERENCES

1. Tso, M.Y.W. and Leung, J.K.C., 1991, Survey of Indoor ^{222}Rn Concentrations in Hong Kong, Health Physics, 60, pp. 237-241.
2. Tso, M.Y.W. and Li, C.C., 1987, Indoor and Outdoor ^{222}Rn and ^{220}Rn Daughters in Hong Kong, Health Physics, 53, pp. 175-180.
3. UNSCEAR, 1988, Ionising Radiation: Sources and Biological Effects, United Nations, New York.
4. Tso, M.Y.W., Leung, J.K.C., Wang, H.D., Wei, S.X., Wang, F.T. and Wang, Q.H., 1989, Summary of Participation in the International Intercomparison of Radon Measurements, Radiation Protection, 9, pp. 177-180.

A CONTROL SYSTEM FOR STANDARD ALPHA AND BETA RADIOACTIVE SOURCES

Simone K. Dias and Linda V.E. Caldas

Instituto de Pesquisas Energéticas e Nucleares
Comissão Nacional de Energia Nuclear
São Paulo

ABSTRACT

A system of alpha and beta radiation detection was designed and constructed, using a plastic scintillator, in order to control the sources used for the calibration of contamination detectors. The obtained results of the short and medium-term stabilities, linearity and energy dependence using three different measurement systems were compared.

INTRODUCTION

The systematic routine monitorations have to be conducted using sensitive detectors in any area where radioactive materials are handled and specially where the possibility of surface contamination exists. The normally used instruments for surface contamination detection are scintillators, proportional counters, semiconductor detectors and Geiger-Müller detectors provided with thin entrance windows. The calibration process of such monitors involves the use of different radioactive sources^{1,2,3}. In the case of alpha radiation, the sources are unsealed, requiring special care during their handling. In order to check these sources periodically a control system was developed.

DESIGN AND CONSTRUCTION OF THE CONTROL SYSTEM

The developed detection system is constituted mainly by a plastic scintillator, a light pipe (Lucite) and a photomultiplier tube. This arrangement can be seen in Figure 1. Three different measurement assemblies were tested: an electrometer Keithley 616 (System 1), an electrometer Keithley 610C (System 2) and a timer-counter (System 3).

The secondary standard set in the case of alpha radiation for calibration of surface contamination monitors is composed by ^{239}Pu , ^{238}Pu , ^{244}Cm , ^{233}U and ^{241}Am sources, with certificates of the Laboratoire de Metrologie des Rayonnements Ionisants and by ^{241}Am sources produced and calibrated at the Nuclear Metrology Laboratory of IPEN. In the case of beta radiation,

the secondary standard sources are $^{90}\text{Sr} + ^{90}\text{Y}$, ^{137}Cs , ^{14}C and ^{36}Cl , all calibrated at LMRI.

RESULTS

a. Short and medium-term stabilities

A source of ^{241}Am (2305 s^{-1}) was used for this study. The best short-term stability (repeatability test) was shown by the System 3: the obtained variation coefficient was lower than 0.11%, while in the case of Systems 1 and 2 it was respectively 0.95 and 0.19%. For the medium-term stability (10 daily measurement series) the obtained variation coefficient was 0.18% for the System 1 and 0.14% for both Systems 2 and 3.

b. Linearity

Two different methods were carried out in this test. First, an ^{241}Am source (2305 s^{-1}) was used and the irradiation time was varied between 0 and 300 seconds. In the second case the control system was exposed to several ^{241}Am sources, with the emission flux varying between 55.3 and 11100 s^{-1} . In both cases a linear behaviour was observed for all three systems.

c. Energy dependence

Alpha and beta radiation sources with different energies were utilized, in order to obtain calibration factors for the control system and to study its energy dependence.

In the case of alpha radiation, in the energy interval of 4.7 and 5.8 MeV, the obtained energy dependence was 31.0 and 37.6% for the Systems 1 and 2 and only 5.3% for the System 3. Exposing the developed instrument to beta radiation, the energy dependence showed values of 19.6, 14.0 and 12.2% for respectively Systems 1, 2 and 3, in the energy interval of 511 keV and 2.0 MeV. Comparing these results, it can be verified that the arrangement with the timer-counter (System 3) demonstrated the lowest energy dependence, a desirable characteristic of such an instrument.

The efficiency of System 3 was determined: 91.8% for alpha radiation (^{241}Am) and 55.9% for beta radiation ($^{90}\text{Sr} + ^{90}\text{Y}$).

Table 1 presents the calibration factors of the control system for ^{241}Am and $^{90}\text{Sr} + ^{90}\text{Y}$ in the case of the three different measurement assemblies.

CONCLUSION

The studied characteristics of the developed control system for alpha and beta sources, ie, the short and medium-term stabilities, the linearity and the energy dependence indicate the system composed by the radiation detector and the timer-counter measurement assembly as the most suitable, although the other two systems showed their usefulness also.

REFERENCES

1. IAEA, 1971, International Atomic Energy Agency, Handbook on Calibration of Radiation Protection Monitoring Instruments, Vienna, Technical Report Series 133.
2. IEC, 1981, International Electrotechnical Commission, Alpha, Beta and Alpha-Beta Contamination Meters and Monitors, Geneva, Publication 325.
3. ISO, 1988, International Standard Organization, Reference Sources for the Calibration of Surface Contamination Monitors, ISO Standard 8769 (E).

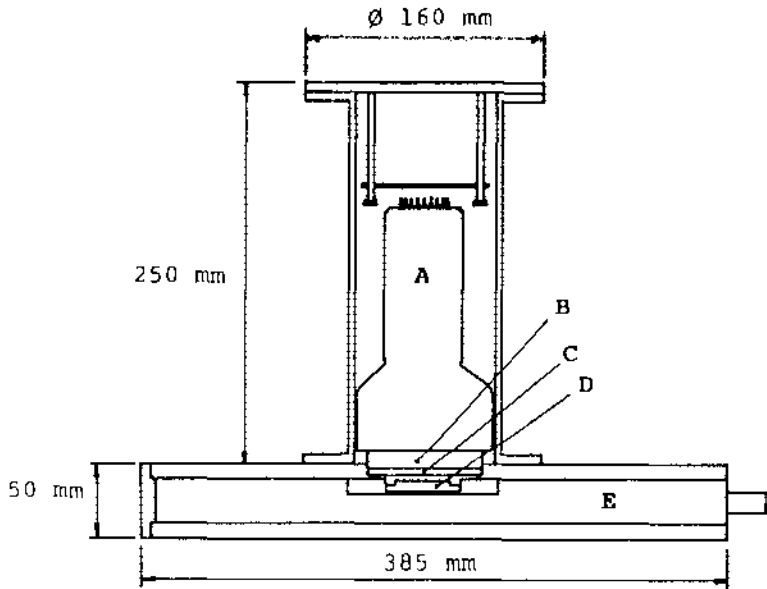

Figure 1: Alpha and Beta Radiation Detection System.
A: Photomultiplier tube; **B:** Light pipe (Lucite, 3 in. diameter and 12 mm thickness); **C:** Plastic scintillator detector (3 in. diameter and 1 mm thickness); **D:** Radioactive source; **E:** Drawer.

TABLE 1
Calibration factors (f_C) of the control systems
for alpha and beta radiation

System	f_C ($s^{-1} \cdot ue^{-1}$)	
	^{241}Am ($167.2 s^{-1}$)	$^{90}\text{Sr} + ^{90}\text{Y}$ ($2930 s^{-1}$)
1	$(1.30 \pm 0.04) \times 10^2$	$(6.07 \pm 0.24) \times 10^2$
2	$(1.22 \pm 0.02) \times 10^2$	$(5.82 \pm 0.25) \times 10^2$
3	$(1.86 \pm 0.03) \times 10^{-2}$	$(2.98 \pm 0.12) \times 10^{-2}$

Systems 1 and 2 : 1 ue = 10^{-8} A
 System 3 : 1 ue = 1 cpm

SIMULTANEOUS MONITORING OF ALPHA AND BETA
EMITTING AEROSOLS IN THE ENVIRONMENT

M. Iwatschenko-Borho, U. Engel, A. Gagel
FAG Kugelfischer, D-8520 Erlangen, Frauenaucherstr. 98

W. Kiese Wetter, T. Naatz, T. Steinkopff
German Meteorological Service, D-6050 Offenbach, Kaiserleistr.

ABSTRACT

Both fixed-filter and step-filter monitors can be used for the on-line surveillance of airborne fission products and trans-uranium elements in the environment. In this paper the specific benefits and drawbacks of these monitoring concepts are discussed. The network of the German Meteorological Service takes advantage of the complementarity of both sampling techniques. The comparability of the data received by different methods is demonstrated by some typical results of environmental measurements.

INTRODUCTION

In Europe the radiological consequences of the nuclear accident at Chernobyl have stimulated the design and the configuration of extended networks for the continuous surveillance of the environmental radioactivity. Nevertheless not all of the radiological features that have been observed in Western Europe can be taken for granted in respect to potential events in the future. But even an analysis of published data concerning the isotopical composition of the Chernobyl-fall-out clearly reveals the necessity of nuclide specific measurements at different locations:

In Germany the observed activity-ratio of Plutonium- to Cesiumisotopes had been in the order of 10^{-5} /1/. This means that the insignificant amount of transuranium elements had been detectable by off-line radiochemical methods only. On the other hand the official russian IAEA-report /2/ states an Pu/Cs activity ratio of $1.7 \cdot 10^{-3}$ for the emitted core material. This discrepancy can be explained by the different processes of emission, transportation and deposition for non-volatile and volatile elements: A comparison of soil samples taken in distances of up to 100 km from Chernobyl and those taken in Western Europe showed a derichment of the heavier particles of the nuclear fuel material by three orders of magnitude with increasing distance to the emittent. Additionally great differences in the isotopical composition of the various contaminated clouds depending on the time of emission at Chernobyl have been found /3/. Taking into account that the inhalation dose factor of $^{239,240}\text{Pu}$ is $3 \cdot 10^4$ higher than for ^{137}Cs /4/ it can be concluded that in the area around Chernobyl α -emitters played an important role in respect to the potential inhalation risk. Since the inhalation of these radioactive particles can be reduced quite effectively by the use of masks or by staying indoors the instantaneous knowledge of the airborne presence of α -emitters can thus be quite essential for the authorities.

REQUIREMENTS FOR ENVIRONMENTAL ALPHA AND BETA MONITORING

Keeping the radiological features of the Chernobyl accident in mind, the following aspects of environmental α - and β -monitoring have to be considered:

- The activity concentration of fission products (β -emitters) can be expected to exceed that of transuranium elements (α -emitters) by several orders of magnitude. Thus the β -sensitivity of the α -measurement has to be very small.

- Transuranium elements often occur as part of 'hot particles', i. e. the spatial distribution of the activity concentration can be quite inhomogeneous. Thus the volumina of the air under investigation should be sufficiently large in order to get a reliable result.

- According to the fact, that the required detection limits of artificial α -activity concentrations are typically two orders of magnitude below the natural background an effective suppression and compensation of the ^{222}Rn -daughters is very essential. Here an on-line discrimination can be performed via an energy analysis of the emitted α -particles, while the most efficient separation technique (simply waiting for the Rn-daughters to decay) yields delayed results only.

- Due to the preferential short-ranged transportation behaviour of non-volatile radionuclides the relative presence of artificial α -activity can be expected to be quite different at different locations of a network. Additionally the higher deposition rate in comparison to the volatile elements leads to a more transient time behaviour as well. Thus an on-line measurement of the α -activity concentration at selected sites of the network is desirable.

- Depending on the kind of nuclear accident the presence of artificial α -activity is related with the observation of other specific radionuclides, for example ^{144}Ce /3/, which might be identified via Γ -spectroscopy. Thus on-line Γ -spectroscopy also yields a first indication concerning the presence of small airborne α -contaminations which might remain below the detection limit of the α/β -monitor.

- Of course the design of the monitoring techniques must fit to the specific requirements of the network. For example the desired minimum response time for an alarm or the availability of skilled crews at the individual stations have to be taken into account.

ENVIRONMENTAL MONITORING CONCEPTS

Different off-line (1,2) and on-line (3,4,5) methods can be applied for the detection of airborne α - and β -contaminations in the environment (see table 1):

- 1) Using high-volume samplers combined with a subsequent radiochemical analysis detection limits in the order of several $\mu\text{Bq}/\text{m}^3$ for a sampling periode of one week can be reached. Though being the only technique for the detection of these (radiologically irrelevant) traces of radioactivity, this

method cannot supply instantaneous data which might be required in a network designed for an early warning. Depending on the distance to the laboratory and the kind of analytical method, a typical delay of at least one day between the end of the sampling periode and the final result can be assumed.

2) The off-line application of the alpha beta pseudo coincidence (ABPD) method /5/ represents a much faster evaluation technique which can be applied in the stations by unskilled personal as well. Here α - and β -detection limits of several mBq/m^3 for a sampling periode of 24 h can be reached.

3) Due to an excellent discrimination behaviour against natural radioactivity the α -energy range discrimination (AERD) method /6/ allows the on-line detection of α - and β -emitters. The detection limit is typically 50 mBq/m^3 for an integration time of two hours. According to the great volume under investigation ($\Phi = 40 \text{ m}^3/\text{h}$) an instantaneous response to the presence of hot particles can thus be combined with a very low detection limit for small but persistent concentrations. The presence of personal is required for the change of the filter only.

4) Much larger service intervals (up to 6 month) can be reached by the use of step-filter monitors /7/ involving silicon detectors. Here typical detection limits for averaging times of several hours are similar to those of AERD-monitors since the much smaller flow-rate ($8 \text{ m}^3/\text{h}$) approximately balances the improved discrimination against natural radioactivity. On the other hand smaller concentrations might remain undetected since the accumulation process is restricted by the filter transportation mechanism.

5) Isotopes which are Γ -emitters as well can be identified by an on-line Γ -spectroscopical step-filter monitor.

	high volume sampler radiochem. analysis	sampler, ABPD - analysis	On-line AERD monitor	On-line α, β step-filter-monitor	On-line γ step-filter-monitor
measured isotopes	α, β, γ	α, β	α, β	α, β	γ
nucleide specific	++	-	-	+(α)	++
discrimination vs. natural activity	++	+	0	+	++
alarm generation	-	-	+	+	+
delay between data request & final result	≥ 1 day	1 h	immediate	immediate	≤ 0.5 h
suitable for uncrewed stations	0	-	0	++	+
service	4h/week	0,5h/day	0,5h/week	1h/0,5 year	1h/week
typical detection limits	-	-	50 mBq/m^3	50 mBq/m^3	200 mBq/m^3
24h	-	10 mBq/m^3	10 mBq/m^3	-	50 mBq/m^3
168h	5 mBq/m^3	-	2 mBq/m^3	-	-

table 1: Application scheme of aerosol monitoring concepts (++ excellent, + good, 0 moderately suited, - unsuited)

EXPERIMENTAL RESULTS

The network of the German Meteorological Service (DWD) includes methode 1, 2 or 3 and 5 (table 1). Figure 1 shows some on-line-data concerning the natural airborne activity gained by an α/β - (methode 3) and Γ -measurement (methode 5) respectively.

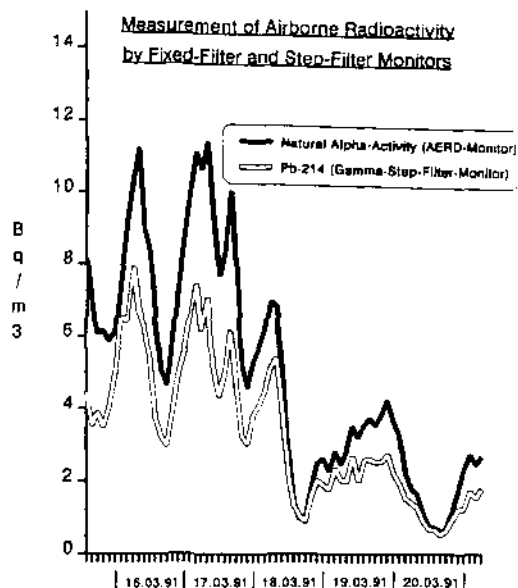

Figure 1:
Immission data measured
at Offenbach, Germany

REFERENCES

- /1/ ISH Institut f. Strahlenhygiene München, 1986, Ergebnisse von Radioaktivitätsmessungen nach dem Reaktorunfall in Tschernobyl, ISH report 99.
- /2/ USSR State Committee on the Utilization of Atomic Energy, 1986, The Accident at the Chernobyl Nuclear Power Plant and its Consequences, IAEA Post-Accident Review Meeting, Vienna.
- /3/ Lindner, G., Kaminski, S., Schell, B., Schodlock, H.-J., Wahl, U., Wilhelm, Ch., 1991, Proc. 25. Jahrestagung Fachverband für Strahlenschutz, Aachen, 259-264.
- /4/ ICRP, 1979, Limits for Intakes of Radionuclides by Workers, ICRP Publication 30.
- /5/ Vaane, J. P., de Ros, E. M. M. , Proc. 1st Int. Conf. Rad. Prot. 1966, 997-1001
- /6/ Iwatschenko-Borho, M., Frenzel, E., Kraut, N., Kreiner, H.-J., Wichmann, H.-P., 1989, Proc. 15th Reg. Conf IRPA in Visby, 487-492.
- /7/ Gagel, A., Iwatschenko-Borho, M., Hofmann, B., Löw, R., Buijs, K., Servranckx, J. P., Burger, P., Wagner, G., Frenzel, E., 1991, Proc. 25. Jahrestagung Fachverband für Strahlenschutz, Aachen, 389-394.

AN APPROVED PERSONAL DOSIMETRY SERVICE BASED ON AN
ELECTRONIC DOSEMETER

T.O. Marshall, E.A. Pook, D.T. Bartlett and J. Hallam

National Radiological Protection Board,
Chilton, Didcot, Oxon, OX11 0RQ, UK

ABSTRACT

An electronic dosimeter has been developed in the U.K. by the National Radiological Protection Board (NRPB) and Siemens Plessey Controls Ltd. It has been designed to measure the quantities $H_p(10)$ and $H_s(0.07)$ for photons and beta-rays and is suitable for use by approved personal dosimetry services.

The specification of the dosimeter and the operational features it provides are described and a summary of the type tests and the dosimeter trials is also given.

INTRODUCTION

Personal dosimetry services, approved by their national authorities for category A workers, invariably use passive dosimeters incorporating photographic film or thermoluminescent detectors. However, for several years the NRPB has felt that the next major development in personal dosimetry should be an electronic dosimeter mainly because the instantaneous indication of radiation levels to the wearer should lead to improved control of exposures and a reduction in individual doses. This became a possibility when an arrangement of solid state detectors and filters was developed at NRPB⁽¹⁾ which was suitable for the measurement of individual dose equivalent penetrating, $H_p(10)$ for photons.

Since then further development has taken place at NRPB⁽¹⁾ for the measurement of individual dose equivalent superficial, $H_s(0.07)$ for beta-radiation. The quantities $H_p(10)$ and $H_s(0.07)$ have been recommended by ICRU⁽²⁾ for individual monitoring.

NRPB and Siemens Plessey Controls agreed to develop jointly the device which will, in due course, be manufactured and distributed by Siemens Plessey.

THE DOSEMETER SPECIFICATION

It is the intention that the device is suitable for use as a legal dosimeter, i.e., one which in the U.K., for example, could be the basis of a dosimetry service, approved by the Health & Safety Executive (HSE) for "Classified" workers.

The dosimeter will measure $H_p(10)$ and $H_s(0.07)$ for photons and beta-rays both as the accumulated dose or instantaneous dose rate and the wearer is free to choose at any time which of these is displayed. The dose range which can be displayed for $H_p(10)$

and $H_p(0.07)$ is 1 μSv to 999.9 mSv. On its own this range is insufficient but the dosimeter will store up to 10 times this value, which will be accessible with an external reading unit. The dose rate ranges which can be displayed for $H_p(10)$ and $H_p(0.07)$ are 1 to 9999 $\mu\text{Sv h}^{-1}$ and 0.01 to 99.9 mSv h^{-1} respectively.

For photons and beta-rays the dosimeter can cover the energy ranges 20 keV to 7 MeV and 250 keV to 1.5 MeV (mean energies) respectively. Over the more important regions of these ranges the response is constant to within about 30% and the variation of response with angle of incidence will be contained within these limits.

Audible and visual alarms are provided, the setting up of which is restricted to authorised persons. The wearer, using keypads provided on the unit, can cause dose rate, or accumulated dose, or the alarm settings or his personal unique identifier to be displayed. Warning signals such as battery low or calibration required are automatically displayed. An essential feature for a legal dosimeter is that the accumulated values of $H_p(10)$ and $H_p(0.07)$ are stored securely. This security will be maintained even if the battery is discharged or the unit is damaged providing the storage chip is intact.

Important internal features are the use of semi-conductor detectors together with state of the art electronics. A customised battery will have a life of at least 1 year under normal conditions. Each dosimeter has a unique identifier and authorised stations (i.e., approved dosimetry services in U.K.) will be able to read and reset the stores for $H_p(10)$ and $H_p(0.07)$ prior to re-issue to a different person. The dosimeter is shown in Figure 1.

TYPE TESTING THE DOSEMETER

The dosimeter is being type tested in order to demonstrate its overall performance characteristics. Central to these tests is an investigation into the way its response varies with radiation type and energy and with the angle of incidence of the radiation. The dosimeter is intended for the measurement of $H_p(10)$ and $H_p(0.07)$ for photons and beta-rays. The above tests are being carried out with ISO reference radiations with energies between 17.4 keV and 7 MeV for photons and with beta particle spectra from ^{204}Tl , $^{90}\text{Sr}/^{90}\text{Y}$ and ^{106}Rh . In all cases the dosimeters will be exposed at angles of incidence 0° , 20° , 40° and 60° . The dosimeters are being exposed on the phantom expected to be recommended by the ICRU for this type of test namely a slab of dimensions 30 x 30 x 15 cm. Appropriate conversion coefficients, recommended by ICRU, are used to convert the air kerma intensity in the radiation beam to $H_p(10)$ and $H_p(0.07)$ in the phantom, i.e., the quantities against which the reading of the dosimeter is compared. The results will be presented in the form of a family of 4 curves being the energy response for each of the angles of incidence. To gain acceptance the mean of these curves at each energy should be within $\pm 30\%$ of that at the calibration energy over the whole energy range. So far this work has been

completed for photon radiations. Figure 2 shows the photon energy response for the dosimeter at angles of 0°, 20°, 40° and 60°. It can be seen that all values of the combined energy and angular response are within the range $1.0 \pm 30\%$.

In addition the dosimeter has been tested against the Draft IEC Standard for pocket alarm dosimeters and the tests have been successful for all requirements of major importance. This standard prescribes an extensive range of tests which includes the following:

- i) effects of temperature and humidity
- ii) effects of electromagnetic and electrostatic fields
- iii) effects of shock, vibration and immersion in water
- iv) the ease of radioactive decontamination

The dosimeter has also been shown to meet the requirements for personal dosimeters given in the Draft CEC document on Technical Recommendations for Monitoring Individuals Occupationally Exposed to External Radiation.

THE WEARER TRIALS

Wearer trials are in progress and are being largely limited to NRPB staff at its centres in Chilton, Leeds and Glasgow using the system described above. The service will be operated from Chilton and the trials at Chilton are being used to simulate an ADS serving its own on-site staff. The staff at Leeds are being used to simulate a remote customer linked to the dose record keeping system by an interactive computerised system and those at Glasgow to simulate a remote customer transferring data by means of some computer compatible medium. During the trials staff are, of course, continuing to wear their current passive dosimeters.

SUMMARY

An electronic personal dosimetry service has been described. The NRPB considers this to be the next logical development in personal dosimetry and it has been shown that the device offers a number of advantages for this purpose.

REFERENCES

1. Burgess P.H. Private communication.
2. International Commission on Radiation Units and Measurements. Determination of Dose Equivalents Resulting from External Radiation Sources. ICRU Report 39, Bethesda, MD, 1985.

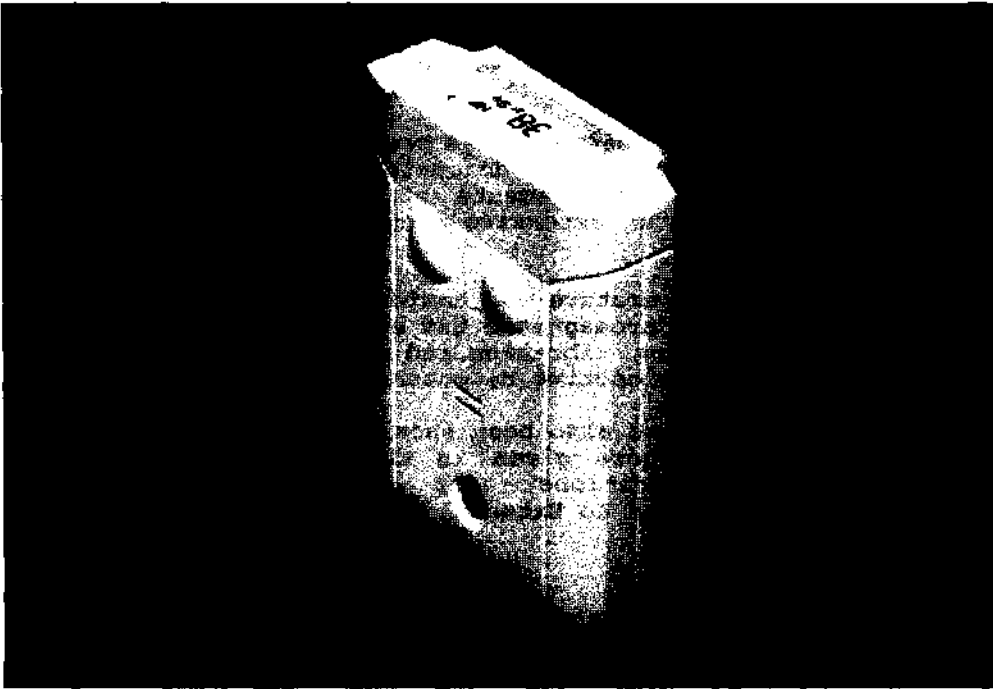

Figure 1 The Electronic Personal Dosemeter

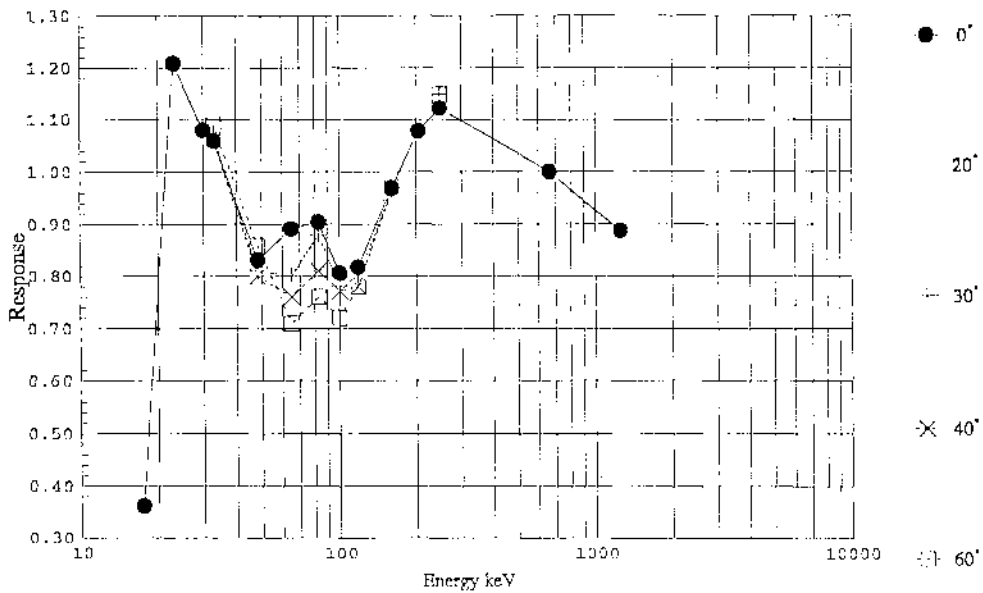

Figure 2 Variation of Response with Radiation Energy and Angle of Incidence

GRAPHITE MIXED $\text{CaSO}_4:\text{Dy}$ TL DOSEMETERS FOR
BETA RADIATION DOSIMETRY

L.L.Campos

Instituto de Pesquisas Energéticas e Nucleares
Comissão Nacional de Energia Nuclear
São Paulo - Brasil

ABSTRACT

Sintered pellets of $\text{CaSO}_4:\text{Dy}$ of different thickness with graphite contents from 0 to 10% were investigated for application for beta dosimetry.

INTRODUCTION

During the last few years many attempts have been made to develop detector devices for assessment of radiation doses from low energy beta rays to the unprotected skin⁽¹⁻³⁾. The Dosimetric Materials Production Laboratory of IPEN developed thin pellets of $\text{CaSO}_4:\text{Dy}$ (0.20 mm thick) for beta radiation detection⁽⁴⁾. This type of dosimeter shows good sensitivity but high energy dependence for beta mean energies below 100 keV. In this work it was investigated the TL characteristics of the sintered $\text{CaSO}_4:\text{Dy}$ dosimeters with graphite contents from 1 to 10% for application for personnel dosimetry.

EXPERIMENTAL MEASUREMENTS

TLD pellets were obtained from a homogeneous mixture of $\text{CaSO}_4:\text{Dy}$ (0.1% mol) phosphor (35% by weight), Teflon powder and graphite (0; 0.5; 1; 2; 5 and 10% by weight). Pellets of this mixture, with a diameter of 6.0 mm and thickness between 0.20 mm and 0.80 mm were first cold pressed and then sintered.

The TL response of these pellets were determined using the Harshaw TL Reader model 2000 (AB). Prior to irradiation, the samples were subjected to an annealing at 300°C for 3 h. They were irradiated under the same conditions. Each reported value corresponds to the average of five measurements.

The beta irradiations were carried out using the beta Secondary Standard System of the Calibration Laboratory of IPEN, with $^{90}\text{Sr} - ^{90}\text{Y}$ (74 MBq), ^{204}Tl (18.5 MBq) and ^{147}Pm (0.5 GBq) sources (manufactured by Buchler & Co., Germany). The detectors were always placed on a 12 mm thick phantom (Lucite) and covered with a 15 μm thick (2.1 $\text{mg}\cdot\text{cm}^{-2}$) polyethylene terephthalate (Hostaphan) foil during the irradiation.

The gamma irradiations were carried out using a ^{60}Co source (1.0 GBq). The samples were always irradiated sealed in Hostaphan foil 15 μm thick and under electronic equilibrium conditions.

RESULTS

The CaSO₄:Dy Teflon pellets with different graphite contents were exposed to 2.58×10^{-5} C.kg⁻¹ (100mR) of ⁶⁰Co gamma radiation. The decrease of the TL sensitivity with increasing graphite content is observed. Pellets with thickness of 0.20 mm showed the highest TL response when exposed to 10 mGy of ²⁰⁴Tl radiation.

The individual reproducibility of the dosimeters was investigated for each dosimeter type by calculating the standard deviation from ten successive dose measurements. The average reproducibility obtained for ten pellets irradiated with 10 mGy (⁹⁰Sr - ⁹⁰Y) under identical conditions was 3% (1σ) for all type of dosimeters.

The dose threshold defined as three times the standard deviation of the zero dose reading of the dosimeters expressed in terms of dose units, was calculated for each type of dosimeter. From Table 1 it can be seen that the dose threshold for dosimeters 0.20 mm thick with graphite content of 10% is approximately 23.0 μGy for gamma radiation of ⁶⁰Co, which is an acceptable level for application for personnel dosimetry.

The TL response of all type of CaSO₄:Dy dosimeters was measured for ⁹⁰Sr - ⁹⁰Y, ²⁰⁴Tl, and ¹⁴⁷Pm beta sources normalized to ⁶⁰Co radiation. The energy dependence for 0.20 mm thick pellets is shown in Table 2. It can be seen that the beta ray response of CaSO₄:Dy dosimeters with a graphite content of 10% gives an optimal response curve when compared with the response curve of pellets without graphite.

After a storage period of one month at room temperature, the results from the stored dosimeters were compared with dosimeters annealed, immediately irradiated, stored for 24 h and then read out: only 3% fading was found in the TL response.

CONCLUSIONS

The graphite mixed CaSO₄:Dy Teflon pellets produced at IPEN appear attractive for beta as well as mixed beta-gamma dose measurements. The reduced energy dependence to beta rays with average energy between 100 and 800 keV makes them useful in personnel monitoring.

REFERENCES

1. Horowitz, Y.S. TL and TL Dosimetry: Vol. II, Ch II p. 62-4, Cleveland, OH: CRC Press.
2. Pradhan, A.S. and Bhatt, R.C., 1977. Graphite-Mixed $\text{CaSO}_4:\text{Dy}$ Teflon Discs for Beta Dosimetry. Phys. Med. Biol. 33, 873-879.
3. Prokić, M. and Christensen, P., 1983. Graphite-Mixed Magnesium Borate TL Dosemeters for Beta Ray Dosimetry. Radiat. Prot. Dosim. 6, 133-136.
4. Campos, L.L. and Lima, M.F., 1987. Thermoluminescent $\text{CaSO}_4:\text{Dy}$ Teflon Pellets for Beta Radiation Detection. Radiat. Prot. Dosim. 18 (2), 95-97.

Table 1 - Effect of graphite content on background TL and dose threshold (0.20 mm thick).

Graphite Content	Minimum Measurable Absorbed Dose			
	^{60}Co	$^{90}\text{Sr}-^{90}\text{Y}$	^{204}Tl	^{147}Pm
%	μGy	μGy	μGy	μGy
0	1.30	1.50	2.70	7.00
0.5	2.90	2.60	4.30	14.00
1	3.60	3.70	5.80	17.00
2	7.60	7.00	8.90	24.00
3	12.00	15.00	20.00	53.00
5	20.00	20.00	33.00	60.00
10	23.00	30.00	36.00	113.00

Table 2 - Energy dependence of 0.20 mm thick pellets with 0% and 10% graphite content.

Source	Mean energy	Relative TL response	
	MeV	0% graphite	10% graphite
$^{90}\text{Sr}-^{90}\text{Y}$	0.80	1	1
^{204}Tl	0.24	0.50	0.90
^{147}Pm	0.06	0.20	0.40

A PARALLEL PLATE IONIZATION CHAMBER FOR ELECTRON DOSIMETRY

Cleber N. de Souza* and Linda V.E. Caldas

Instituto de Pesquisas Energéticas e Nucleares
Comissão Nacional de Energia Nuclear
São Paulo, Brazil

ABSTRACT

A parallel plate ionization chamber for electron dosimetry was developed and tested in relation to the metrological characteristics: short and medium-term stabilities, leakage current and response to electron beams up to 13 MeV. The polarity effect was also investigated. The obtained results show that they are within the international limits recommended for a secondary standard chamber.

INTRODUCTION

The increasing utilization of linear accelerators in radiotherapy treatments has imposed the necessity of use of parallel plate ionization chambers for dosimetry of the electron beams with energies lower than 15 MeV, as recommended by the dosimetry protocols^{1,2,3}. In the present work an ionization chamber of this kind was designed and constructed at the Calibration Laboratory of IPEN. Such chambers may be calibrated in future by comparison with cylindrical ion chambers in a phantom irradiated by ⁶⁰Co gamma rays⁴, without the need for an electron fluence correction.

DESIGN AND CONSTRUCTION OF THE IONIZATION CHAMBER

The parallel plate ionization chamber developed in this work has a circular shape, is mainly made of Lucite and presents an active volume of 0.06 cm³. The entrance window consists of a thin polyethylene foil coated with graphite (0.84 mg.cm⁻²); the collecting electrode is made of a graphite block (3 mm thickness) and a graphite coated slice of Lucite (0.15 mm). The distance between the electrodes is 2 mm; the external diameter and height of the chamber are 54 and 17.5 mm respectively. A schematic diagram of the chamber is shown in Figure 1.

* Fellowship from Conselho Nacional de Desenvolvimento Científico e Tecnológico, Brazil.

EXPERIMENTAL MEASUREMENTS

The chamber was connected to a Keithley model 617 electro meter in order to allow measurements with both polarities. The tests were made in electron beams up to 13 MeV, using a phantom made of Lucite slices.

The short-term stability was determined through 10 consecutive measurements using a check source of ^{90}Sr . The percentual standard deviation showed values between 0.14 and 0.34%. For the medium-term stability test 15 series of measurements were performed at different days. The response presented a variation lower than 0.5% in relation to the mean value: Figure 2.

The leakage current was measured several times during 1 h with intervals of 5 min and showed always values lower than 0.4%. The chamber presented an ion collection efficiency higher than 99%, when operated at a collecting potential of 250 V.

The polarity effect of the chamber was investigated in a 10 MeV electron beam, taking measurements for both polarities and varying the Lucite absorber thickness (z) up to the practical electron range (R_p). The polarity effect was lower than 1% at the maximum ionization depth and it increased for greater depths: Figure 3. All standard deviations of these measurements were lower than 0.25%.

According Goswami and Kase⁵ the replacement factor for parallel plate ionization chambers in electron beams above 13 MeV is approximately 1 and probably not significant. In the present work the chamber response was compared to that of a calibrated thimble chamber (Capintec-C II model 66080, 0.6cm^3) in a electron beam of 13 MeV. The obtained calibration factor was 1.04 cGy/s.u. (s.u.: scale unit).

CONCLUSION

The developed parallel plate ionization chamber presented metrological characteristics, as short and medium-term stabilities, leakage current, ion collection efficiency, polarity effect and calibration factor comparable to those of commercial ionization chambers. The obtained values, within the recommended ones for this kind of radiation, demonstrate the usefulness of the chamber for electron dosimetry.

ACKNOWLEDGEMENTS

The authors wish to express their thanks to Mr. Marcos Xavier for technical assistance.

REFERENCES

1. AAPM, 1983, American Association of Physicists in Medicine. A Protocol for the Determination of Absorbed Dose from High Energy Photon and Electron Beams. Med. Phys. 10 (6) 741-771.
2. IAEA, 1987, International Atomic Energy Agency. Absorbed Dose Determination in Photon and Electron Beams. An International Code of Practice, Vienna, Technical Report Series 277.
3. AAPM, 1991, American Association of Physicists in Medicine. Clinical Electron Beam Dosimetry, Med. Phys. 18 (1) 73-109.
4. Attix, F.H., 1990, A Proposal for the Calibration of Plane-Parallel Ion Chambers by Accredited Dosimetry Calibration Laboratories, Med. Phys. 17 (5) 931-933.
5. Goswami, G.C. and Kase, K.R., 1989, Measurement of Replacement Factors for a Parallel-Plate Chamber, Med. Phys. 16 (5) 791-793.

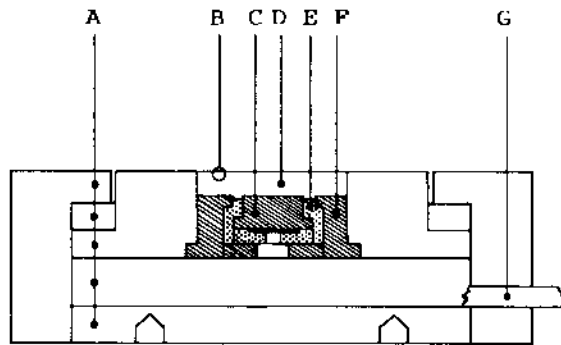

Figure 1: Schematic diagram of the parallel plate ionization chamber for electron dosimetry.

A: Chamber body (Lucite); **B:** Entrance window;
C: Collecting electrode (graphite); **D:** Active volume (0.06 cm^3); **E:** Insulator (Teflon); **F:** Guard-ring (graphite); **G:** Triaxial cable.

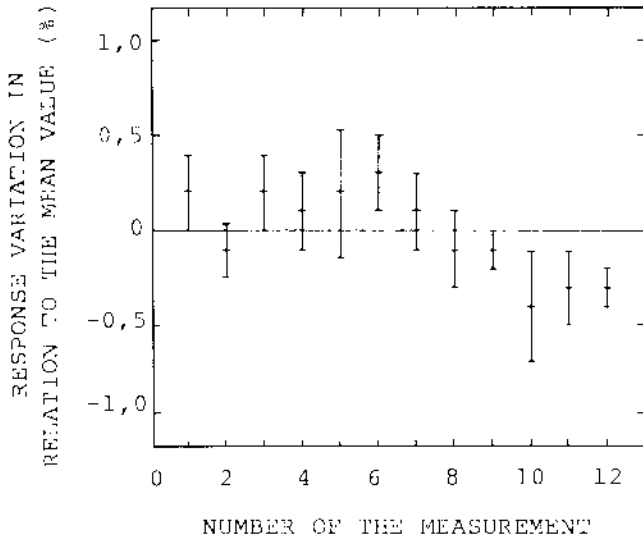

Figure 2: Medium-term stability test.

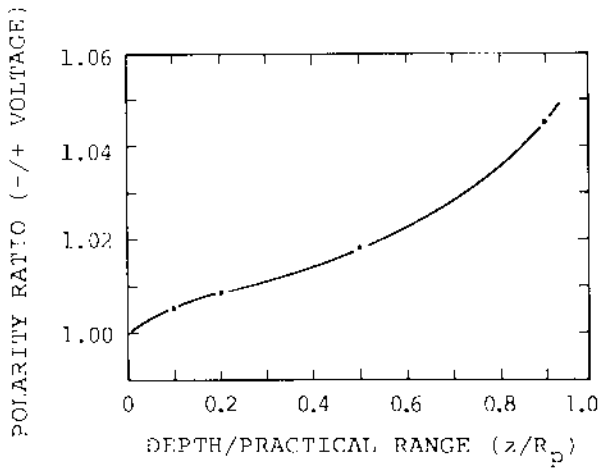

Figure 3: Polarity effect of the ionization chamber in an electron beam of 10 MeV.

THORIUM BIOASSAY OF MINERAL SANDS WORKERS

G S Hewson¹ and J J Fardy²

1. Department of Mines, 100 Plain Street, East Perth, Western Australia.
2. Australian Nuclear Science and Technology Organisation, Lucas Heights, New South Wales.

ABSTRACT

The concentration of thorium in the blood serum and urine of Western Australian mineral sands workers was studied to complement estimates of radiation dose derived from air sampling measurements. The measured levels were significantly lower than the values predicted from the application of ICRP biokinetic models to air sampling data. In many cases, the levels were of the same order as background levels measured in occupationally unexposed persons.

AIM OF PROJECT

The study was designed to enable comparisons between measured values of thorium in the blood and urine of mineral sands workers and:

1. measured values for unexposed persons;
2. values reported in the literature for other worker groups exposed to thorium; and
3. predicted values based on air sampling measurements undertaken by the industry.

It was considered that such comparisons would facilitate a comparative assessment of the relative level of exposure.

BACKGROUND

Workers in the mineral sands industry are exposed to varying concentrations of the radioactive mineral, monazite, which contains 6-7% by weight of the radioactive element thorium. The principal radiation exposure pathway is thought to be through inhalation of alpha radiation associated with airborne dust. Estimates of internal radiation dose using the assessment protocols and data contained in ICRP Publications 26 and 30 indicate that up to 15% of the approximately 1500 workers in the mineral sands industry may exceed the formal investigation level of 15 mSv⁻¹.

The existing radiation dose assessment method is based on air sampling, which requires assumptions to be made concerning a number of environmental factors, including the size of the dust particles, the solubility of the dust, the incorporation of dust into the body and the effectiveness of respiratory protective equipment in reducing exposure to dust.

Bioassay monitoring for thorium will assist in improving knowledge of its metabolic behaviour. The blood and urine samples provide an indication of the amount of thorium circulating in the body and being cleared from the body, respectively. Such bioassay studies assist in refining our estimates of radiation dose following inhalation of thorium.

STUDY GROUP AND METHODS

The project commenced in April 1991 and involved thirty four (34) mineral sands workers across five processing plant sites. In addition, a number of samples were collected from unexposed persons to obtain an indication of background levels of thorium.

The cumulative internal exposure history for each worker was obtained from industry records of airborne radioactivity (gross alpha activity) measurements submitted to the Department of Mines. It was assumed that workers were exposed to class Y (i.e. avidly retained) Th ore dust with an AMAD of 10 μm . Twenty five millilitres of blood and 1 L of urine were collected using rigorous collection protocols to minimise the possibility of contamination. The samples were analysed using chemical/radiochemical neutron activation analysis procedures.

RESULTS

The results of testing are summarised in the attached figure. The measured average levels for the industry are compared with the expected level, based on industry monitoring of the workplace atmosphere, and also average background levels. The levels of thorium in urine and blood are expressed in parts of thorium per billion parts of either urine or blood.

The following observations are made on the results obtained in this study:

1. The levels of thorium in urine are very low and typically more than ten times lower than those expected based on air sampling measurements.
2. The levels of thorium in blood are typically more than two times lower than those expected based on air sampling measurements.
3. The urine results for many workers are not substantially different from those reported for members of the public and are lower than those reported for other groups of workers exposed to thorium.

Results of Bioassay Measurements

(a) Urine Sampling

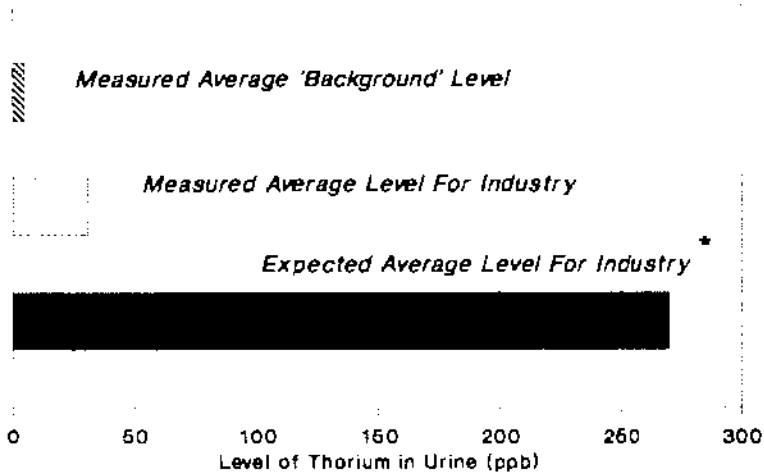

(b) Blood Sampling

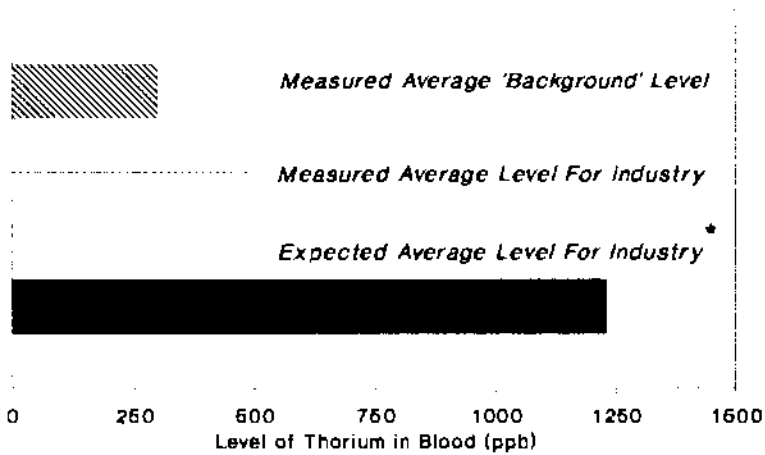

- * *Expected Level Based Upon Application Of ICRP Biokinetic Models To Airborne Radioactivity Measurements.*

4. The level of thorium in blood are higher than some reported background levels.

The blood testing is considered to be more reliable than urine testing since varying intake of fluids such as water and alcohol, or loss of water by perspiration, will cause significant differences in the amount of urine excreted.

CONCLUSIONS

This testing program indicates that the absorption of thorium is much less than has been previously assumed. This result suggests:

- (1) present industry monitoring procedures may overstate the radiation doses received by workers. The lower results could arise if respirators have been worn for "dusty" jobs and no allowance has been made for their protective effect; or
- (2) thorium may be much less soluble than expected and only a small amount passes into the blood or urine. If this is so, then thorium will not be carried to sensitive organs such as bone.

It is likely that, on the basis of this study, average radiation doses in the industry may only be about one-half of those reported.

While this monitoring has indicated that existing protective measures are effective in controlling radiation exposure to low levels, it is still important to maintain radiation exposures As Low As Reasonably Achievable.

REFERENCES

1. Hewson, G.S. and Fardy, J.J., 1991, Thorium Bioassay of Mineral Sands Workers, submitted for publication.
2. Hewson, G.S., 1990, Radiation Exposure Status of Mineral Sands Industry Workers (1983-1988), Rad. Prot. in Australia, 8:3-12.
3. Hewson, G.S. and Hartley, B.M., 1990, Radiation Research Priorities in the Mineral Sands Industry. J. Radiol. Prot., 10:221-229.
4. Dang et al., 1989, A Sensitive Method for the Determination of Th in Body Fluids. Health Phys., 57:393-396.
5. Lipsztein et al., 1989, Bioassay Monitoring Studies for Thorium. Radiat. Prot. Dosim., 26:57-60.

GHUUN388

THE N-16 GAMMA RADIATION RESPONSE OF GEIGER-MUELLER TUBES

D. J. Allard, A. M. Nazarali and G. E. Chabot

Arthur D. Little, Inc., Acorn Park, Cambridge, MA 02140; WIPP, P.O. Box 2078, Carlsbad, NM 88220; University of Lowell, 1 University Ave., Lowell, MA 01854

ABSTRACT - This paper describes an evaluation of various Geiger-Mueller (GM) tubes for N-16 gamma radiation response. The work is an extension of investigations regarding the various radiation response characteristics of these devices. Previously acquired photon energy response data were from 10 keV to 1.25 MeV. Utilizing the 6 MeV gamma ray of N-16, the pair production interaction response with different GM tube styles was studied. The new relative response ratios of N-16 to Cs-137 are presented with a discussion of results. Additionally, two full energy response curves are presented.

INTRODUCTION AND METHODS

Recently, evaluations for radiation response characteristics of GM tubes with respect to beta energy, dose rate, photon polar and photon energy response have been performed in conjunction with the NRPB in the UK (Allard 1987). That work investigated photon energy response from 10 keV to 1.25 MeV. The dominant interactions in this energy range are photoelectric and Compton scattering. An investigation presented herein extended the photon energy testing into the 6 MeV range using an N-16 source. At this energy the pair production interaction will become more apparent with respect to detector response. Various styles of "pancake", mica end window, thin wall, thick wall and energy compensated GM tubes were included in this study. The mechanical aspects of the various styles are noted in Table 1 and TGM Detectors' product specifications. In this evaluation a portable high voltage supply/digital scaler was set up adjacent to the N-16 source at the University of Lowell's research reactor facility. This source has been fully characterized for the specific purpose of measuring response of portable radiation protection instruments (Neault, 1980). It should be noted that a 1.5 inch thick iron plate was placed in front of the source to attenuate the high energy beta component and provided secondary electron buildup. This arrangement also furnished an exposure scenario that is similar to what is encountered in a nuclear power plant. The various GM tubes were irradiated with the N-16 source at known exposure rates, and observed counts and times recorded. Efforts were made to obtain at least 10,000 counts for statistics. Similarly, the same detectors were irradiated with a calibrated Cs-137 source. The background was measured in each area and corrections applied. Collected data were then used to determine a count rate per unit exposure rate value. A response ratio of N-16 to Cs-137 was then calculated in order to fold this information into the previously acquired photon energy response measurements made at NRPB.

RESULTS AND DISCUSSION

Table 1 is a summary of the N-16 to Cs-137 response ratios. As noted, the relative response ratio varied from nearly unity to about two. Considering the interactions and number of secondary charged particles produced, this would be expected. If one were to plot of photon fluence versus photon energy, a peak would be observed below 200 KeV. This is mentioned in that GM tubes are basically photon counters, and will more or less exhibit the same generally shaped curve. However, differences in GM tube construction does cause notable discrepancies at high photon energies and variable peak spread at low photon energies. Figures 1 and 2 are energy response curves for a bare and energy compensated version of a GM tube. The data presented are a combination of the NRPB and this study's results (i.e. N-16 data point).

GM tubes will respond to any charged particle that enters their sensitive volume. A discharge may be produced by charged particles directly entering the tube through a mica window or thin cathode wall. Alternately a discharge may result from secondary electrons; thus, the construction of any given GM tube will greatly influence an energy response curve by the complex contribution of primary photon transmission/attenuation and secondary particle production/attenuation at various depths in the GM tube window, wall or outer energy compensation filter. Again, the data shown in Figures 1 and 2 are the relative response values for the GM tube on an exposure rate basis. Because Cs-137 is a very common calibration source, by convention 662 keV is used as the normalization point. This allows comparison of tubes that may have quite different gamma ray sensitivities due to overall size.

As can be noted in Figure 1, the "thin wall" style GM tube with an 80 mg/sq. cm window provides excellent transmission for low energy photons below 100 keV. However, relative to Cs-137 it does over-respond by nearly a factor of 13 at 70 keV. This results from the high photon fluence being transmitted through the cathode wall, a high interaction probability, and the subsequent discharge events being counted. In the intermediate energies the response is relatively flat, but does begin to increase slightly above 1 MeV. The latter is due to the increase in number of secondary charged particles from pair production. Over-response below about 200 keV may be reduced by adding a thin layer filter of high atomic number metal over the tube with an appropriate open area. This effectively attenuates a portion of the low energy photon fluence. With proper engineering, one can easily obtain a +/-20% response from 50 keV to 1.25 MeV using a "thin wall" GM tube and energy compensation filter. However, as can be noted by comparing the response curves in Figures 1 and 2, the high atomic number filter actually causes an increased over-response in the 6 MeV range compared to the bare tube. This is no doubt due to energetic secondaries produced in the energy compensation filter, passing through the GM tube cathode wall and causing a discharge.

Acknowledgement - The authors wish to thank TGM Detectors, Inc. (Waltham, MA, U.S.A.) and Centronic Limited (Croydon, U.K.) for their financial support of this project.

REFERENCES

Allard, D.J., Geiger-Mueller Tube Radiation Response Characteristics, Proceedings of the Health Physics Society's 21st Midyear Topical Meeting on Power Reactor Health Physics, Miami, FL, 1987.

Neault, P.J., The Dosimetry of Nitrogen-16, University of Lowell Masters Thesis, 1980.

Table 1. Ratio of N-16 Gamma Response Relative to Cs-137

GM Tube	Ratio	Comments
N1002/8767	1.88	Through mica window.
N1002/BNC	1.90	Through mica window.
N1003	1.96	Through mica window.
N201	1.71	Through 0.047" SS wall.
N205	1.90	Through 0.010" SS wall.
N210/BNC	1.58	Through 0.109" SS wall.
H220/7840	1.90	Through mica window.
N107	1.61	Through 30 mg/sq.cm SS wall.
N112	1.65	Through 30 mg/sq.cm SS wall.
N114	1.73	Through 30 mg/sq.cm SS wall.
N115-1	1.09	Through 80 mg/sq.cm SS wall.
N115-1S1	1.42	Through 80 mg/sq.cm SS wall with high Z filter.
N116-1	1.24	Through 80 mg/sq.cm SS wall.
N116-1SE	1.63	Through 80 mg/sq.cm SS wall with high Z filter.
N117-1	1.74	Through 30 mg/sq.cm SS wall.
N117-1S	1.73	Through 30 mg/sq.cm SS wall with high Z filter.
N118-1	1.03	Through 120 mg/sq.cm SS wall.
N118-1S	1.49	Through 120 mg/sq.cm SS wall with high Z filter.
N302	1.76	Through 0.020" SS wall.
N305	1.82	Through 0.010" SS wall.
N305S	1.99	Through 0.010" SS wall with high Z filter.
NP315-6	1.52	Through 0.020" SS wall, platinum plated inside.
NP334-6	1.48	Through 0.012" SS wall, platinum plated inside.
NP358-6	1.69	Through 0.009" SS wall, platinum plated inside.

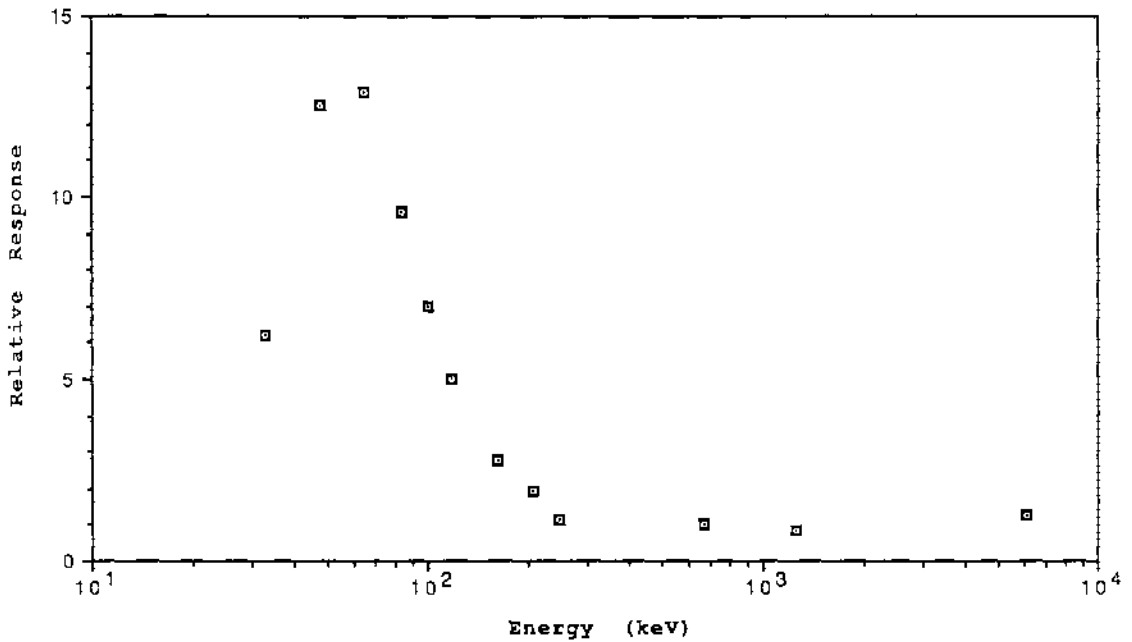

Fig. 1: Photon Energy Response of N116-1 miniature "thin wall" GM tube, normalized to unity at 662 keV with beam perpendicular to detector wall.

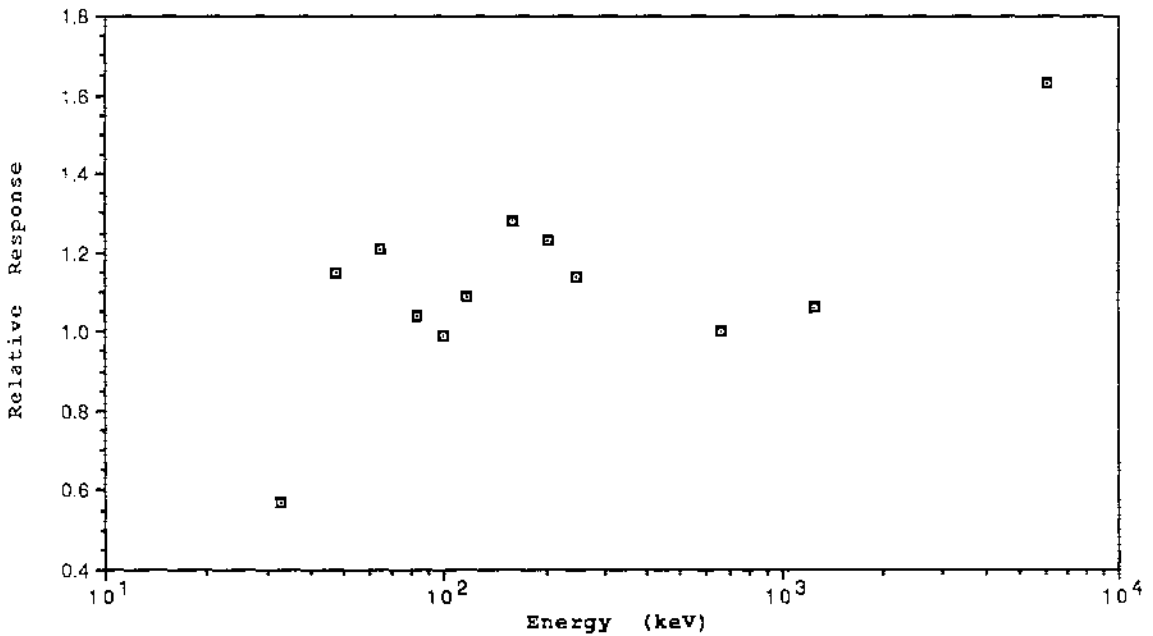

Fig. 2: Photon Energy Response of N116-1SE energy compensated miniature "thin wall" GM tube, normalized to unity at 662 keV, same geometry.

**"L'ENVIRONNEMENT" ET LA SURVEILLANCE
DE LA RADIOACTIVITE DANS L'AIR**

B. ROTTNER Docteur Ingénieur E.S.P.C.I.
Directeur Technique / SAPHYMO-PHY

SAPHYMO-PHY

18, Rue de Villeneuve SILIC 551.
94643 RUNGIS CEDEX
FRANCE Tél. : 33 (1) 46.87.25.16.

**"THE ENVIRONMENT" AND THE MONITORING
OF RADIOACTIVITY IN AIR**

The french company, SAPHYMO-PHY, presents two state of the art products for "the Environment" and the monitoring of radioactivity in air :

- The **RAM 900** : Aerosol (Alpha and Beta) activity measurement.
- The **SIAM 9000** : - Aerosol (Alpha, Beta, Gamma) activity measurement
- Gaseous Iodine Gamma volumic activity measurement
(High resolution gamma spectrometry)
- **RAM 900** :

La RAM 900 est une balise de surveillance de la radioactivité de l'air : elle mesure l'activité alpha et bêta des aérosols.

La mesure est faite par pompage de l'air à travers un filtre déroulant séquentiel et par spectrométrie alpha/bêta en ligne à l'aide d'une diode Silicium. La spectrométrie permet d'une part de discriminer les alpha des bêta, et d'autre part, de mesurer l'énergie de chaque alpha.

La RAM 900 peut ainsi mesurer et compenser l'activité alpha bêta naturelle - due aux descendants solides des radons - quelle que soit la situation radon, situation extrêmement variable suivant la météorologie et le lieu d'implantation de la balise. Un détecteur gamma permet de mesurer l'ambiance gamma et de compenser son influence sur la voie bêta. Les limites de détection en isotopes artificiels atteignent :

- 1 mBq/m³ pour les alpha
- 100 mBq/m³ pour les bêta.

- SIAM 9000 :

La SIAM 9000 intègre une voie de mesure type RAM 900 avec des filtres individuels et effectue une spectrométrie gamma haute résolution (grâce à un détecteur au Germanium refroidi à l'azote liquide) sur les aérosols et sur les iodés gazeux, ce qui lui permet d'identifier et de quantifier les éventuels contaminants.

Les deux détecteurs (Germanium et Silicium) sont placés dans des enceintes en plomb hermétiques afin de les protéger de l'effet de l'ambiance gamma.

Le prélèvement d'iode est effectué par pompage de l'air à travers une cartouche au charbon actif.

Un bras manipulateur robotisé manipule les filtres et les cartouches.

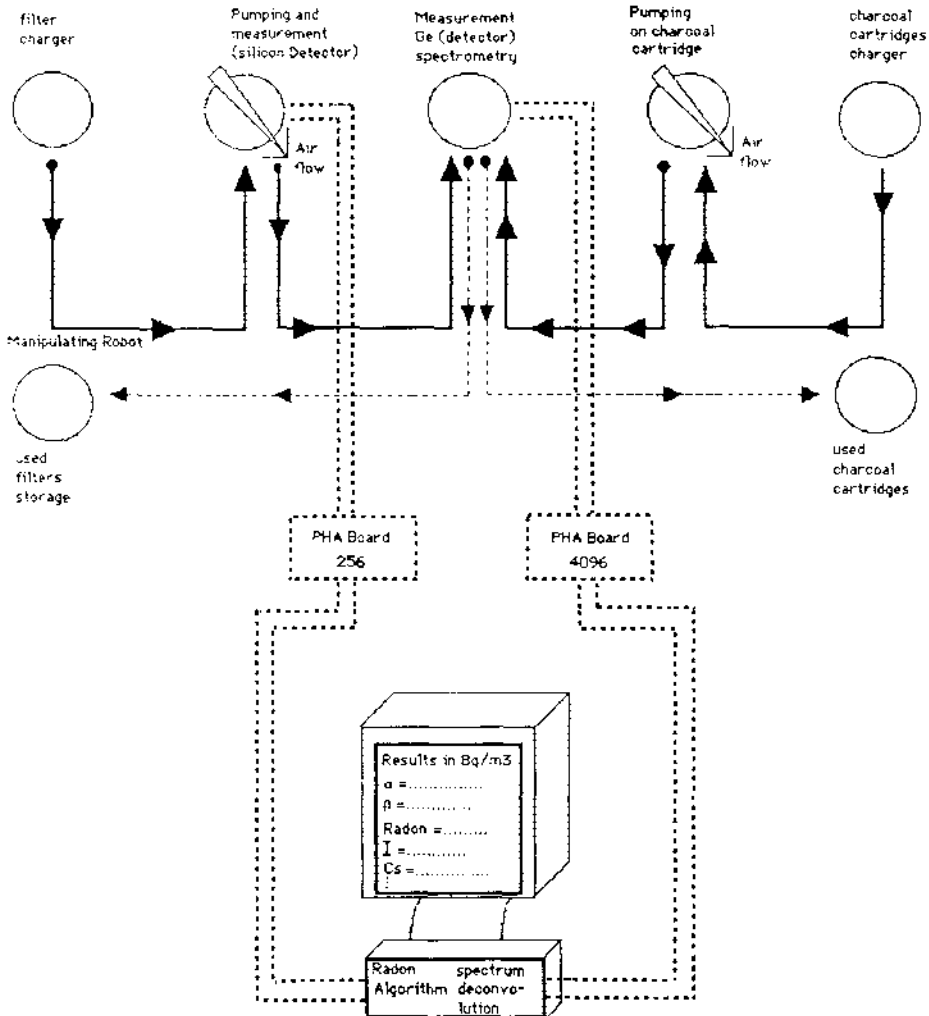

COMPARAISON DE TECHNIQUES DE MESURE DU RADON 222 (COMPTEUR
PROPORTIONNEL, DIODE SILICIUM (P.I.N.) ET DETECTEURS SOLIDES DE
TRACES NUCLEAIRES)

D. KLEIN ^{1,2}, R. BARILLON ¹ et A. CHAMBAUDET ¹

1 - Laboratoire de Microanalyses Nucléaires, U.F.R. des Sciences
et de Techniques, Université de Franche Comté,
25030 Besançon, France

2 - Laboratoire de Metrologie des Interfaces Techniques,
IUT Belfort-Montbéliard, Rue Engel-Gros, BP 527,
90016 Belfort Cedex, France

AN INTERCOMPARISON OF TECHNIQUE TO MEASURE RADON 222
(PROPORTIONAL COUNTER, SILICON DIODE AND SOLID STATE NUCLEAR
TRACK DETECTOR)

An intercomparison in laboratory conditions was made between three different methods to measure radon 222. One instantaneous technique based on the use of a proportional counter and the others by integrating method base on the use of diode silicium (P.I.N.) and Solid State Nuclear Track Detector. The test was performed in a standard source in L.M.N. at Besançon. Good agreement was obtained between all the techniques.

INTRODUCTION

Le radon 222, gaz radioactif de la famille de l'uranium 238 est le principal composant de la radioactivité atmosphérique. Le suivi de sa concentration est donc fondamental dans le domaine des Sciences de la Terre et dans le domaine de la radioprotection, que cela soit dans les habitations ou sur les sites miniers.

Dans le but de disposer d'une instrumentation adaptée à l'ensemble des conditions de terrain (maison, mine, site géologique, etc...), le Laboratoire de Microanalyses Nucléaires a développé différentes techniques de mesure.

Ces techniques sont : des détecteurs solides de traces nucléaires (LR 115 et CR 39), un compteur proportionnel et un détecteur à diode silicium.

LES TECHNIQUES DE DETECTION

- Le compteur proportionnel

Le compteur proportionnel a été spécialement développé au Laboratoire de Microanalyses Nucléaires pour la mesure en continu du radon 222 avec la possibilité de fonctionner sur des terrains très hostiles tels que les volcans.

Cet ensemble de détection est autonome et portable. Sa limite de détection inférieure à 40 Bq.m⁻³ et son temps de réponse immédiat permet son utilisation pour de nombreuses applications.

Cet appareil a déjà été utilisé et a montré son efficacité pour différentes applications en radioprotection (mesure de

concentration dans des mines et des habitations) et dans le domaine des Sciences de la Terre (caractérisation des mouvements terrestres, prospections géologiques, étude des fluides géothermiques et suivi des variations de radon aux édifices volcaniques).

- Diode silicium (P.I.N.)

Utilisant les effets de l'irradiation des particules alpha sur les semi-conducteurs, un détecteur de radon est en cours de développement. Il utilise en base de détection du matériel Hamamatsu standard et une électronique associée qui est développée au Laboratoire de Microanalyses Nucléaires pour son utilisation aux mesures de terrain.

Cette technique est en cours de développement et nous présentons ici les premiers résultats obtenus à partir du prototype de laboratoire qui vient d'être développé et qui donne une mesure intégrée directement accessible sur le terrain par connexion d'un micro-ordinateur portable sur une eprom de stockage intégrée à l'électronique de détection.

- Les Détecteurs Solides de Traces Nucléaires (D.S.T.N.)

L'utilisation de D.S.T.N. pour la mesure de l'émanation radon, s'est imposée pour de nombreuses applications. Deux types de détecteurs sont utilisés au Laboratoire: le LR 115, nitrate de cellulose commercialisé par la Société KODAK, sensible aux particules alpha d'énergie comprise entre 0,5 et 4 MeV et le CR 39, polycarbonaté commercialisé par la Société TASTRAX, sensible pour toutes la gamme des énergies de particules alpha.

Pour cette technique, les détecteurs sont placés dans des cellules de mesure de géométries spécifiques développées pour des mesures de terrain et ensuite après un temps d'exposition variant de 10 à 60 jours les détecteurs sont analysés au laboratoire par traitement d'image automatique.

- Utilisation des appareils sur le terrain

Pour réaliser des mesures sur le terrain, la méthode que nous utilisons actuellement repose sur l'utilisation complémentaire du compteur proportionnel et des détecteurs de traces nucléaires. Le compteur proportionnel est placé en un point du site et son information permet de suivre les variations de la concentration radon par pas de trente minutes et de choisir le temps d'exposition des détecteurs nucléaires en fonction de la concentration en radon au point de référence. Les détecteurs nucléaires quant à eux sont placés sur l'ensemble de la zone d'intérêt et leur analyse permet d'accéder à la cartographie en radon de toute la zone.

En ce qui concerne le détecteur à diode silicium, il n'a pas été encore utilisé en routine sur le terrain, mais leur utilisation est appelée à remplacer à court terme les détecteurs polymériques.

RESULTATS EXPERIMENTAUX

Pour réaliser l'intercomparaison deux chambres sont utilisées. La première (Figure 1) permet la mesure de la concentration en radon dans un flux d'air sec, la seconde (Figure 2) permet la mesure dans un atmosphère humide.

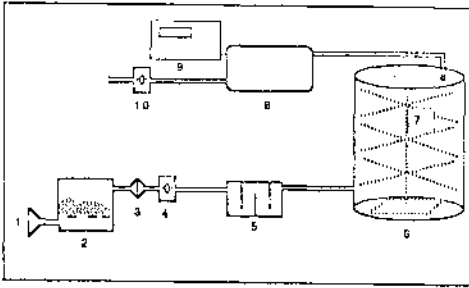

Figure 1

1. entrée du flux d'air
2. source d'uranium naturel
3. filtre
4. pompe
5. piège desséchant
6. chambre d'analyse
7. portoir
8. compteur proportionnel
9. électronique associée
10. pompe

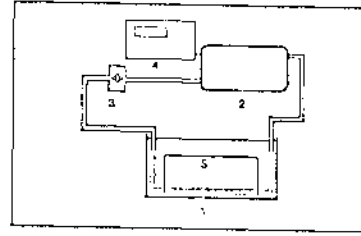

Figure 2

1. eau chargée en radon
2. compteur proportionnel
3. pompe
4. électronique associée
5. portoir

La mesure en continu de la concentration en radon est accessible par le compteur proportionnel en impulsion par seconde, en ce qui concerne la diode silicium (PIN) et les détecteurs solides de traces nucléaires, la mesure est réalisée par intégration sur une période de 5 jours et les résultats sont exprimés en trace par centimètre carré ou impulsion par heure. La figure 3 présente l'ensemble des résultats.

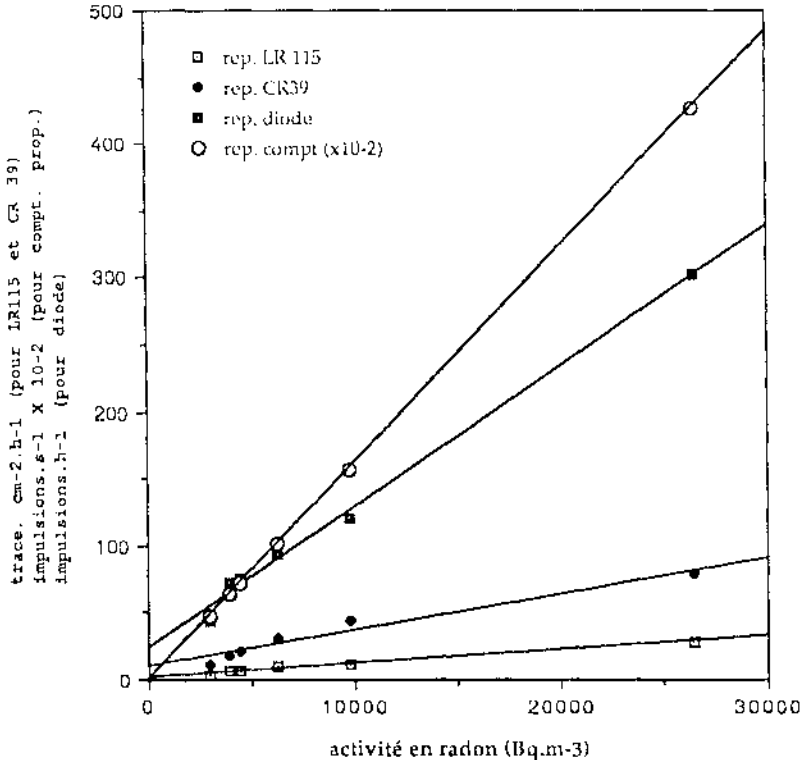

Figure 3 : Principaux résultats

CONCLUSIONS

Le tableau suivant donne l'ensemble des avantages et inconvénients des techniques utilisées

	Avantages	Inconvénients
- Compteur proportionnel	- mesure en continu - autonome et portable - sensibilité < 40 Bq.m ³	- coût - encombrement
- Diode silicium (PIN)	- bonne sensibilité - mesure directe sur site	- mesure intégrée - coût
- Détecteur Solide de Traces Nucléaires	- coût - facilité de mise en oeuvre	- mesure intégrée - traitements en laboratoire post-exposition

Les résultats obtenus sont en accord et il est à noter que l'avantage principal de la mesure intégrée obtenue par la diode silicium est la rapidité d'acquisition de l'information qui ne nécessite aucun traitement en laboratoire.

BIBLIOGRAPHIE

1. D. KLEIN
"Un appareil de mesure de terrain du radon 222, en continu".
Revue générale Nucléaire , N°2, p 134-138 (1989).
2. A. CHAMBAUDET, M. CIEUR, M. HUSSONNOIS et D. KLEIN
"A portable system for the continuous measurement of radon 222 in hostile geophysical environments"
Nuclear Instrumental and Method B, B61, pp 244-250, 1991
3. D. KLEIN, A. CHAMBAUDET, Y. CAUCHOIS, R. BARILLON et L. DREZET
" Developing measuring technique in radioprotection for tracking radon in situ "
Nuclear Tracks and rad. Meas. , Vol. 19, N°4, (1991).
4. R. BARILLON, D. KLEIN , A. CHAMBAUDET, F. MEMBREY et M. FROMM
"Additional uses of polymeric nuclear track detectors (CR39 and LR115) for measuring radon emanation"
Nuclear Tracks and rad. Meas. , Vol. 19, N°4, (1991).

AIR CONTAMINATION MEASUREMENTS CONNECTED WITH THE THERAPEUTIC USE
OF I-131

M. Kristufek¹, E. Ogris², H. Aiginger¹

¹Atominstitut der Österreich. Universitäten

²Institut für Nuklearmedizin, KH der Stadt Wien, Lainz

ABSTRACT

By measuring the Radioactivity in the air of a Radionuclide Therapie - Unit it could be observed that the changes of the radioactivity concentration are closely related to the functional state of the patient's thyroid. In patients with thyroid carcinoma the organification of administered J-131 depends on the size and function of the postoperatively remaining thyroid tissue and this in turn influences the exhalation of J-131 by the patient. In a patient with a relatively large amount of remaining thyroid tissue the shape of the observed time activity curve shows an ascending slope reaching a maximum at 7,5 h. After the maximum the curve follows a monoexponential decrease with a disappearance half-life time of 10,7 h. In patients suffering from hyperthyroidism several cyclic changes of radioactivity concentration could be observed as a result of the organification and the release of J-131 after deiodination of endogenous labelled thyroid hormones.

INTRODUCTION

Since radioactive Iodine and its stable isotopes have the same chemical and physiological properties, it can be used for diagnosis and treatment of various thyroid disorders. J-131 is used for therapy because of its β -emission (606 keV, directly ionising radiation, small range). The gamma-radiation (364 keV, penetrating radiation) on the other hand can be used for diagnostic procedures like uptake measurements and scintigraphy of the thyroid gland. Mainly two types of thyroid disorders are subject for therapy with J-131:

Carcinoma of the thyroid and hyperthyroidism. The Radioactivity administered for treatment of thyroid cancer ranges from 1850 to 5550 MBq (50-150 mCi). The corresponding Radioactivity for treatment of hyperthyroidism ranges from 185 to 1110 MBq (5-30 mCi) corresponding to an absorbed organ dose of 100 - 200 Gy for therapy of so called Grave's disease and up to 400 Gy for treatment of toxic thyroid nodules. The estimation of the individual dose for treatment is made using a formulation which contains the 24 h J-131 uptake in % of a standard-dose and the effective J-131 half-life time.

Since the patient after treatment can be considered as a radioactive source, he has to stay 3 - 4 days in a special designed therapy Unit for radiation protection of the nursing personal. Within 48 h J-131 is mostly excreted (65 %) in the urine. About 30 % of the administered dose are excreted by stool, the remaining 5 % are excreted by sweat and exhalation.

Due to the fact that J-131 is also exhaled from the patient, a monitoring of the radioactive concentration in the air has to be done using aerosol monitors.

The aim of our study was:

1. to investigate the activity concentration of exhaled J-131 in the room air
2. to investigate whether the time course of activity concentration is specific for a certain type of thyroid disorder after J-131 treatment.

MATERIAL AND METHODS

In order to measure the concentration of radioactive iodine in the air with acceptable accuracy, it is necessary to suck the air through a filter. The activity absorbed on the filter is measured with a NaI-crystal coupled with a photomultiplier.

Assuming that all the concentration of activity is uniformly distributed in the air of the room and is only time-dependent, the infinitesimal change of absorbed activity $dA(t)$ during the time-interval dt comes up to

$$dA(t) = C(t) \cdot Q \cdot F \cdot dt - \lambda \cdot A \cdot dt$$

- A(t) activity on the filter
- C(t) concentration of activity (activity / volume)
- Q sucking rate
- λ decay constant
- F efficiency of filter

The relation between the activity in the filter and the concentration of activity in the air yields

$$\frac{dA}{dt} + \lambda A = Q \cdot F \cdot C(t)$$

For finding a solution of the above equation the assumption was made that the concentration between two data points was considered to be constant.

(A_i, A_{i+1} ...activity at the time t_i, t_{i+1}) With $C(t)=C_i$ the solution of the differential equation can be written as

$$A_{i+1} = A_i e^{-\lambda(t_{i+1} - t_i)} + \frac{QF}{\lambda} C_i (1 - e^{-\lambda(t_{i+1} - t_i)})$$

With respect to $x = \lambda(t_{i+1} - t_i) \ll 1$ we can approximate the concentration of activity to

In our carcinoma patients 1,2 the half-life time of whole-body retention was 22,6 h (large amount of remaining tissue) and 19 h (small rest of remaining tissue) respectively. The blood disappearance half-life time in patient 1 was 14,4 h and 15,3 h in patient 2.

Regarding the concentration of J-131 in air after administration of the therapeutic dose to patient 1 a single peak of maximum activity at 9,9 h with a disappearance half-life time of 10.7 h could be observed. After treatment of patient 2 the maximum activity was reached at 3,0 h. The disappearance half-life time was 3,1 h.

In hyperthyroidism 3 peaks of radioactivity with a mean disappearance half-life time of 1,6 h could be registered.

DISCUSSION

In our investigations we compared the whole-body retention curve (% of administered dose), the course of the activity concentration in the blood (% dose/L blood) and the course of the radioactivity concentration in the air of the therapy Unit (nCi/m³) of patients with different types of thyroid disorders.

In patients with carcinoma of the thyroid a single peak of radioactivity could be detected. The organification of anorganic J-131 depends on the volume and the function of the remaining thyroid tissue. If this volume is relatively small, low uptake of administered J-131 and rapid whole-body clearance will take place. If the volume of the remaining thyroid tissue is comparatively large, considerable uptake of J-131 by the thyroid gland and labelling of endogenous thyroid hormones will take place.

The deiodination of these organic compounds leads to another rise of activity in the air exhaled by the patient. So, a second lower peak of activity in the air is registered. The same phenomenon will take place in the treatment of hyperthyroidism. Due to the rapid J-131 turnover up to 3 activity peaks can be detected in the air of the room.

REFERENCES

1. Mück, K., Messung der ¹³¹J-Konzentration in der Reaktorabluft, Mitteilung der Österreichischen Studiengesellschaft für Atomenergie (Seibersdorf)
2. Glöbel, B., et al, "Radioaktive Isotope in Klinik und Forschung" Strahlenschutzprobleme beim Umgang mit radioaktivem Iod in der Medizin, 13. Band/Gasteiner Symposium 1978, Verlag H. Egermann 1978)
3. Bolek, W., 1990, Meßfehlerbestimmung bei Jodmonitoren, Praktikum-Atominstitut der Österreichischen Universitäten

$$C_i = \frac{\lambda A_{i+1} - A_i(1-x)}{QF \left(x - \frac{x^2}{2} \right)}$$

Finally a five-point smoothing has been done.

Patient 1: Thyroid Carcinoma
 Therapeutic activity: 3700 MBq
 Activity in the air: Patient 1

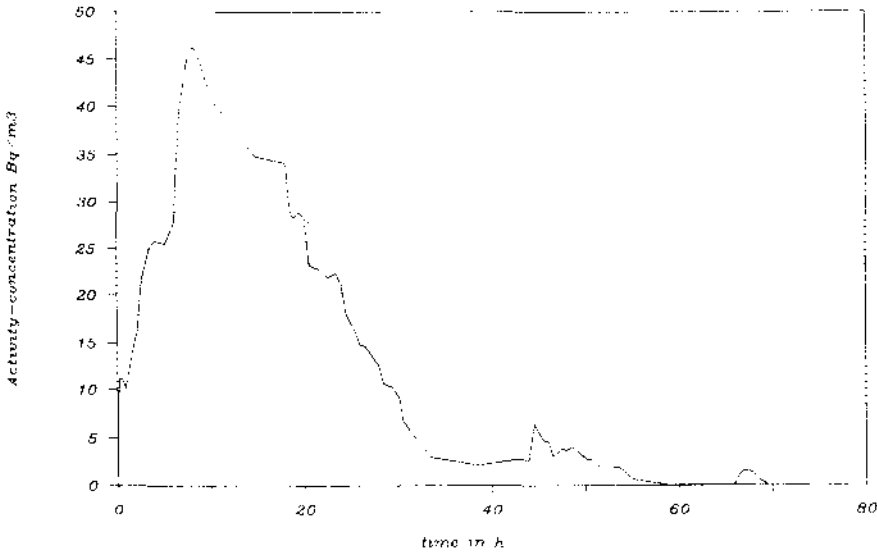

Patient 3: Hyperthyroidism
 Therapeutic activity: 1110 MBq
 Activity in the air: Patient 3

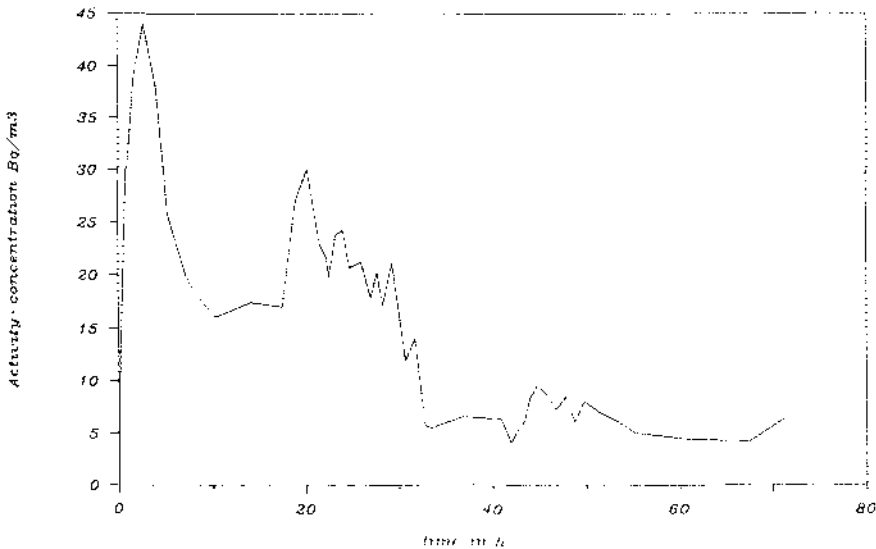

LEVELS OF POLONIUM-210 IN SOME BEVERAGES AND IN TOBACCO

C. H. Colangelo, M. R. Huguel, M. A. Palacios and A. A. Oliveira

Gerencia de Seguridad Radiológica y Nuclear
Comisión Nacional de Energía Atómica
Buenos Aires -República Argentina

ABSTRACT

The objective of the present work is the estimation of the Polonium-210 content in some beverages and in tobacco, in order to assess the corresponding collective doses to the population in Argentina. Yerba mate, an autochthon plant of South America, tea leaves, their infusions and ground coffee were analyzed as well as tobacco. Collective doses due to annual consumption of the beverages described, resulted in values from 6 man.Sv to 1200 man.Sv. Results for Polonium-210 in tobacco ranged from 10 Bq kg⁻¹ to 80 Bq kg⁻¹. Doses due to the use of tobacco were not assessed since an appropriate metabolic model was not found.

INTRODUCTION

Polonium-210 is a naturally occurring radionuclide in the environment and it is considered one of the highly toxic radioisotopes. It is an α emitter, T_{1/2} 138 days, but in spite of its relatively short half life it is maintained in the atmosphere due to longer lived precursors. Polonium-210 in food is an important route of intake [1].

ANALYTICAL METHOD

Solid samples were homogenized, spiked with Polonium-208 as a tracer, and wet ashed with concentrated nitric acid and hydrogen peroxide [2]. The insoluble was discarded because of negligible levels of activity [3].

Yerba mate infusions were prepared with 25 g per liter of boiling water and filtered five minutes later; tea infusions were done in the same way but 10 g of tea leaves were used. The chemical procedure was the same as before, but less insoluble remained.

Nitrates were eliminated, the solution was adjusted to a hydrochloric acid concentration of 0.5 N, ascorbic acid was added to keep iron reduced and Polonium was deposited on silver disks, 25.4 mm in diameter, with constant stirring during 3

hours at 85°C [2] [4].

The deposited activity was measured by α spectrometry with a Si surface barrier detector (1000 mm²) and a Canberra Series 30 Multichannel.

The radiochemical yields for Polonium-208 were quite low and widespread, mainly in the solid samples, with values fluctuating between 20 % and 50 %.

The results obtained are shown in TABLES I to IV.

DISCUSSION

If we compare levels of Polonium-210 in yerba mate and tea leaves with values published for different vegetables [5] [6], a higher bioconcentration in the former is noticeable. Nevertheless, the fraction of Polonium-210 actually extracted into the infusions was between 15 % and 63 %, representing an annual dose by ingestion between 28 $\mu\text{Sv y}^{-1}$ and 86 $\mu\text{Sv y}^{-1}$ (TABLE I). The values corresponding to tea leaves and its infusions are shown in TABLE II. Dose estimations were performed by applying representative consumption rates [7] and dosimetric factors [8] [9]. We assumed f_1 as 0.2 in our calculation.

The annual doses due to yerba mate infusions are six times higher than the doses for tea infusions.

Collective doses, estimated considering the consumption rate during 1990 for Argentina, were 1200 man.Sv. and 6 man.Sv for yerba mate and tea infusions, respectively. As a matter of fact, if we compare the annual collective dose in Argentina due to the consumption of yerba mate with the corresponding collective dose due to previously published data of Polonium-210 in the Argentine diet [10], it results that the former is almost 3 times greater than the latter. It must be taken into account that the beverages analyzed are not included in the total diet, in spite of their important levels of consumption.

Besides, phosphate fertilizers may be discarded as a source of Polonium-210 [11] since their use in yerba mate and tea production in Argentina is insignificant [12].

As the activity levels of Polonium-210 for ground coffee (TABLE III) were negligible, their infusions were not considered for the estimation of the annual doses by ingestion.

Regarding tobacco, only activity levels are given in TABLE IV, since it is difficult to adopt a simple respiratory model in order to calculate the annual doses. Anyway, the results obtained are much higher than the corresponding values for Indian tobacco, but close to U.S.A. data [13].

- TABLE I -

Yerba Mate		Yerba Mate Infusions		
Trademark	Bq kg ⁻¹ (a)	Bq L ⁻¹ (a)	Bq y ⁻¹ (b)	μSv y ⁻¹ (c)
A	14 [±] 0.9(2) [*]	0.25 [±] 0.05(4)	90	80
B	18 [±] 0.9(12)	0.25 [±] 0.04(2)	90	80
C	16 (1)	0.21 [±] 0.05(3)	75	65
D	19 (1)	0.06 [±] 0.04(4)	26	22
E	--	0.28 (1)	100	86

- TABLE II -

Tea Leaves		Tea Infusions		
Trademark	Bq kg ⁻¹ (a)	Bq L ⁻¹ (a)	Bq y ⁻¹ (b)	μSv y ⁻¹ (c)
G	7.5 [±] 0.8(4) [*]	0.02 (1)	7.3	6.3
H	8.3 [±] 0.6(4)	--	--	--
I	13 [±] 1.4(4)	0.04 [±] 0.01(2)	15	13
J	1 (1)	0.017 [±] 0.002(4)	7.3	6.3

- TABLE III -

Ground Coffee	
Trademark	Bq kg ⁻¹ (a)
K	0.38 [±] 0.01 (5) [*]
L	0.19 (1)
M	0.25 [±] 0.02 (4)

- TABLE IV -

Tobacco	
Trademark	Bq kg ⁻¹ (a)
N	10 [±] 2.5 (3) [*]
O	80 [±] 4 (4)
P	53 [±] 5 (4)
Q	77 [±] 4 (4)
R	18 [±] 0.4 (7)

*Figures in brackets indicate No of samples
(a) Concentration
(b) Total Activity Consumed
(c) Annual Effective Equivalent Doses

Uncertainties quoted are at the 95 % confidence level.

REFERENCES

- [1] Parfenov, Y. D., 1974, Polonium-210 in the Environment and in the Human Organism, Atomic Energy Review, Vol 12, No 1 pp 75-143.
- [2] R. B. Holtzman, 1987, The Determination of ^{210}Pb and ^{210}Po in Biological and Environment Materials, Journal of Radioanalytical and Nuclear Chemistry, Articles, 115, No 1 pp 59-70.
- [3] K. Bunzl, W. Kracke and W. Kreuzer, 1979, ^{210}Pb and ^{210}Po in liver and kidneys of cattle. 1. Animals from an area with little traffic or industry, Health Physics, 37, pp 323-330.
- [4] J. D. Smith and T. F. Hamilton, 1984, Improved Technique for recovery and measurement of Polonium-210 from environment materials, Analytica Chimica Acta, 160, pp 69-77.
- [5] R. N. Khandekar, 1977, Polonium-210 in Bombay Diet, Health Physics, 33, pp 148-150.
- [6] W. R. Hansen and R. L. Waters, 1970, Plant Uptake of ^{210}Po from soil, Radiation Botany, Vol. 10, pp 371-375.
- [7] Ministerio de Economía, Secretaria de Agricultura, Ganadería y Pesca, 1991, Personal Communication.
- [8] Kendall, G. M., Kennedy, B. W., Greenhulgh, J. R., Adams, N. and Fell, T. P., 1987, Committed Dose to Selected Organs and Committed Effective Doses from Intakes of Radionuclides. NRPB-GS7 (HMSO).
- [9] Kendall, G. M., Harrison, J. D. and Fell, T. P., 1988, Report of the Nuclear Energy Agency Expert Group on Gut Transfer Factors: Implications for dose per unit intake, Radiation Protection Dosimetry, Vol. 25, No 1, pp 59-65.
- [10] Beninson, D., 1972, UNSCEAR 72, United Nations Scientific Committee on the Effects of the Atomic Radiation. Ionizing Radiation on: Levels and Effects, Vol 1, pp 82. Unpublished data.
- [11] T. Izak-Biran, T. Schelesinger, R. Weintgarten, O. Even, Y. Shamai and M. Israeli, 1989, Concentration of U and Po in Animal Feed Supplements, in poultry meat and in eggs, Health Physics, 186, No 3, pp 315-319.
- [12] Ministerio de Agricultura de la Provincia de Misiones, 1991, Personal Communication.
- [13] D. R. Singh and S. R. Nikelani, 1976, Measurement of Polonium Activity in Indian Tobacco, Health Physics, Vol 31, pp 393-394.

DOSE EQUIVALENT ESTIMATE OF WORKS IN A BRAZILIAN MONAZITE SAND PLANT

Ney, C.L.V., Tauhata, L. And Oliveira Filho, D.S.
Instituto de Radioproteção e Dosimetria (IRD)
Comissão Nacional de Energia Nuclear (CNEN)
Av. Salvador Allende, s/nº - Barra da Tijuca - C.P. 37750
CEP.: 22642 - Rio de Janeiro - Brasil

ABSTRACT

Dose equivalent estimate of workers in a Brazilian monazite sand plant, due to concentration of thorium in the air is presented, using in air monitoring program and utilizing calculation model described in publication nº 30 of the International Commission on Radiological Protection (ICRP).

The sample area, the number of measurements and the results evaluation were made using the experimental design techniques. The results of the dose equivalent estimation due to internal and external radiation exposure indicate the existence of operation areas, for example mill and magnetic field separation, where the dose values surpassed the recommended limits, demanding improvement in radiological protection and the modification of the engineering process, in order to obey the international standards.

INTRODUCTION

The Nuclear Energy National Commission (CNEN) has been developing for many years programs of accompanying of radiological conditions at installations that use ores with reasonable thorium and uranium tails, as those that processes monazite sand mill to produce rare earth and trisodic phosphate. The Brazilian industry analysed, processes monazite with the following sequences of operation: magnetic field separation, milling, alkaline treatment, trisodic phosphate filtration and thorium and uranium cake filtration.

The radiological conditions evaluations were performed by an area monitoring program in the various processes steps location. The results obtained from monitoring were considered as input data in the dose equivalent calculation model, recommended by ICRP publication nº 30⁽¹⁾.

METHODOLOGY

The use monitoring program performs the sampling of measurement in the positions of major occupation of workers, inside of a process area. The permanence time used was the time of labour agreement, i.e., 40 hours/week.

The evaluation of the dose was given by the sum of the doses due external and internal exposure. The dose due to external exposure was estimated by direct measurement in the radiation field, using a Geiger Muller detector, and considering the quality factor for gamma radiation equal to 1. The dose due to internal radiation was estimated by indirect method, measuring the portion that was inhaled through the determination of the concentration of radionuclides in the air, sampling the air and total alpha counting, and multiplying by permanence time, and using models for internal dose calculation.

The main difficult in the monitoring program is to find the distribution representative value or values of the results. It was resolved by using the technique of statistics planning. The planning took into consideration that the main source of fluctuation would be the measurement of the sample point and time/day of its execution.

Therefore, the value of an individual measurement was expressed by:

$$Y_{ijk} = \bar{Y} + P_i + D_j + PD_{ij} + \varepsilon_{(ij)k}$$

where:

Y_{ijk} - individual measurement value

\bar{Y} - distribution mean value

P_i - measurement influence in a "i" point

D_j - measurement influence in a "j" day

PD_{ij} - combined influence in a "i" point and in a "j" day

$\varepsilon_{(ij)k}$ - variation due random error and other influences.

Using this equation we obtain the number of measurement, the measurement points and sampling days. Hence, we draw lots the days and points sequence to be monitored, to obtain an statistics planning of the type "totality random". The obtained results were submitted to variance analysis.

Using the results distribution of the gamma exposure rate and radionuclide concentration in air, we estimate the dose equivalent using the dosimetric model for the determination of internal and external dose.

RESULTS AND DISCUSSIONS

The estimates of the dose equivalent due to external exposure are presented in table 1. The results do not present higher risks to the workers.

Table 1 - Annual dose equivalent due to external exposure to gamma radiation in several areas of the installation.

Processing area	Dose (mSv)
Monazite mill	15,4
Magnetic separation	35,0
Light fraction deposition	21,0
Autoclave (alkaline treatment)	8,0
Filter-press	10,5

The dose equivalent results due to internal exposure to radiation are presented in table 2. All the results are higher than the limits set by safety series n° 82. That indicates the need for improvement in the radiation protection and the modification in the industrial process.

Table 2 - Annual dose equivalent due to internal exposure.

Processing area	Mean Concentration (Bq/m ³)	Dose (mSv)
Monazite mill	0,25	150,6
Magnetic separation	0,56	300,0
Light fraction deposition	0,43	259,0
Autoclave (alkaline treatment)	0,20	120,5
Filter-press	0,13	78,3

The total dose equivalent are presented in table 3.

Table 3 - Total annual dose equivalent.

Processing area	Dose (mSv)
Monazite mill	166,0
Magnetic separation	335,0
Light fraction deposition	280,0
Autoclave(alkaline treatment)	128,5
Filter-press	88,3

The results in table 3 show that all the values are higher than the primary limits (50 mSv/year). To avoid those doses it was adopted the following remedial actions: reduction of working journey; the use of masks for radioactive particulate; and modifications in the processing, like deactivation of the magnetic separation.

CONCLUSIONS

1) The monazite processing to obtain rare earth trissodic phosphate, in areas that have associated thorium, can yield doses equivalents up to 335,00 mSv a year, mainly during milling and magnetic separation.

2) According to the results from mean concentration given in table 2 and considering the limits for thorium associate ore dust, $0,082 \text{ Bq/m}^3$, by safety series 82, we conclude:

a) For free air sampling one should use techniques to retain particles of breathing size such as Cyclones.

b) The total alpha technique is not adequate to apply those limits for concentration. It is necessary a additional technique that allow discriminat the contribution from thorium, radium and uranium.

c) Since the dose equivalent values are greater than 3/10 of the primary limit, it is recommended a individual monitoring program using personal air sampler and/or bioanalysis.

3) The Company should execute cost-benefit analysis to obtain a conclusive solution for the radiological problems.

BIBLIOGRAPHY

- 1 - International Commission on Radiological Protection, Limits for Intakes of Radionuclides by workers, ICPR nº 30, (1978)
- 2 - Ney, C.L.V., Determination of the Dose and Risks in the Thorium Cycle, Master Thesis, IME (1988)
- 3 - International Atomic Energy Agency, Application of the Dose Limitation System to the Mining and Milling of Radioactive Ores, Safety Series nº 82 (1987).

MESURES DANS UNE MINE D'URANIUM DE LA GRANULOMETRIE DES AEROSOLS ET DES DESCENDANTS DU RADON

D. BOULAUD, J.C. CHOUARD

CEA/Institut de Protection et de Sûreté Nucléaire
DPEI/SERAC/LPMA, BP 6, 92265 FONTENAY-AUX-ROSES CEDEX, France

SUBMICRON-SIZED AEROSOL AND RADON PROGENY MEASUREMENTS IN A URANIUM MINE

Submicron-sized aerosol was studied in a uranium mine using an Electrical Aerosol Analyzer and a Differential Mobility Particle Sizer. In addition radon progeny particle size distributions were measured using a prototype instrument developed by us (SDI 2000). The number weighted mean electrical mobility diameters and the geometric standard deviations ranged respectively from 0.05 to 0.1 μm and 1.8 to 2. The gross alpha activity weighted mean thermodynamic diameters ranged typically from 0.1 to 0.2 μm .

INTRODUCTION

La seconde campagne européenne d'intercomparaison des méthodes de mesure du radon s'est déroulée du 29 juin au 7 juillet 1989 sur le siège minier de Bellezane (Division Minière COGEMA de La Crouzille, France) [1]. La section de la galerie est de 10 m² avec des vitesses moyennes d'air de l'ordre de 1,3 m/s. Au cours de cette campagne, la caractérisation de la granulométrie des aérosols était assurée ainsi que la mesure de la distribution en dimension de l'activité alpha globale. L'objet de cet article, outre la caractérisation de l'aérosol d'une mine d'uranium, est de montrer comment ces deux mesures peuvent être reliés.

METHODES DE MESURE - APPAREILLAGES

Mesure de la distribution en dimension de l'aérosol

Deux dispositifs fondés sur les propriétés électriques étaient utilisés :

- l'analyseur électrique d'aérosol (EAA modèle 3030 de TSI, St Paul, Mn, USA),
- l'analyseur différentiel de mobilité électrique (DMPS modèle 3932 de TSI, St Paul, Mn, USA)

EAA : Le principe de comptage et de sélection en dimension de ce dispositif est basé, premièrement sur un processus de charge des particules par un nuage d'ions unipolaires, deuxièmement sur une mesure de la distribution en mobilité électrique des particules ainsi chargées. La connaissance de la loi de charge permet alors de remonter à la distribution en dimension de l'aérosol. Le domaine effectif de mesure s'étend de 0,01 à 1 μm . Dans notre application, cet appareil fonctionnait automatiquement, une mesure étant effectuée toutes les 15 minutes. Un PC assurait à la fois la commande, l'acquisition et le stockage des données. L'EAA nous fournissait l'évolution au cours du temps de la distribution en dimension numérique de l'aérosol, caractérisée principalement par le diamètre médian numérique, l'écart type géométrique et la concentration en nombre.

DMPS : Le principe de sélection en dimension de ce dispositif est basé, premièrement sur un processus de mise à l'équilibre de

Boltzmann des particules par passage au travers d'un nuage d'ions bipolaires, deuxièmement sur une mesure de la distribution en mobilité électrique en utilisant un analyseur différentiel qui permet une meilleure résolution que l'EAA. La détection des particules est assurée en aval de l'analyseur par un compteur de noyaux de condensation (CNC, TSI, 3030, St Paul, Mn, USA). Ce dispositif permet de couvrir un domaine s'étendant de 0,008 à 0,4 μm . Le DMPS nous fournissait le diamètre médian numérique et l'écart type géométrique de l'aérosol.

Mesure de la distribution en dimension de l'activité alpha globale

Nous avons utilisé un prototype développé par nos soins et dénommé SDI 2000 (Spectromètre Diffusionnel et Inertiel). Il permet de couvrir un vaste domaine de dimensions s'étendant de 0,0075 à 15 μm en diamètre. Une description complète du SDI 2000 a déjà été publiée [2, 3]. Ci-dessous, on trouvera une description succincte des principaux composants et du fonctionnement. La partie inertielle est constituée d'un impacteur en cascade de huit étages (ANDERSEN mark II) dont les diamètres de coupure s'échelonnent entre 0,35 et 7,5 μm pour un débit nominal de 28,3 l/min. La partie diffusionnelle est constituée par six tubes disposés en parallèle qui contiennent des lits granulaires ayant des hauteurs et des diamètres de billes différents. Dans notre application particulière, l'impacteur était réduit aux trois derniers étages et un canal de la batterie de diffusion était neutralisé. De plus, un ensemble de grilles, dimensionné pour piéger la fraction libre des descendants du radon était placé en amont du SDI. Dans ces conditions, le domaine couvert s'étendait de 0,01 à 2 μm . Pour ce type de dispositif associant un impacteur à une batterie de diffusion, les dimensions caractéristiques sont soit aérodynamique (impacteur), soit thermodynamique (batterie de diffusion). Ceci signifie que pour un dépôt majoritairement dans l'impacteur on détermine un AMAD (Activity Mean Aerodynamic Diameter) et que pour un dépôt majoritairement dans la batterie de diffusion on accède à un AMTD (Activity Mean Thermodynamic Diameter). Après la mesure, l'ensemble des filtres et des plaques de collection étaient récupérés et analysés par comptage alpha. Les chaînes de comptage se composaient d'un détecteur de silicium implanté et d'une échelle de comptage multivoie couplée à un calculateur. Du fait des délais dans le démontage du SDI et la récupération des différents échantillons, la distribution en dimension des descendants du radon est représentée en activité alpha totale, car il n'est pas possible d'accéder à la distribution des différents descendants du radon.

RESULTATS EXPERIMENTAUX

Noyaux de condensation

La concentration en noyaux de condensation a été mesurée en continu durant toute la durée de l'intercomparaison. Celle-ci a varié entre 30 000 et 200 000 particules/cm³ avec des valeurs moyennes par demi-journée comprises entre 60 000 et 90 000.

Distribution en dimension de l'aérosol

Pour une journée représentative, on a représenté sur la figure 1 les variations du diamètre moyen numérique de l'aérosol

à partir des mesures effectuées avec l'EAA et le DMPS. On constate que l'amplitude de ces variations est faible et qu'elles sont bien reproduites simultanément par les deux dispositifs. Néanmoins, un léger écart est observé entre les deux appareils. Les variations de l'écart type géométrique sont très faibles et celui-ci est typiquement compris entre 1,8 et 2.

Distribution en dimension de l'activité alpha globale

A titre d'exemple, on a représenté sur la figure 2 une distribution en dimension de l'activité alpha globale obtenue au cours de la même journée (mesure à 16 heures) à partir des prélèvements effectués avec le SDI 2000. Au cours de cette étude, les mesures au SDI et au DMPS étaient simultanées.

DISCUSSION

Afin de relier les deux types de mesures décrites dans le paragraphe précédent, on peut, à partir de la distribution en dimension numérique obtenue au DMPS, calculer la distribution en dimension de la fraction attachée des descendants du radon, en utilisant les éléments théoriques permettant de décrire l'attachement. Ces développements théoriques ont fait l'objet de nombreux travaux que nous ne rappellerons pas ici [4, 5]. Le coefficient d'attachement utilisé est celui introduit par Porstendorfer [6], avec comme valeur du coefficient de diffusion de la fraction libre pour le ^{218}Po , celle qui est couramment admise (0,068 cm^2/s [5]). Sur la figure 3, on a donc porté les valeurs des diamètres moyens en activité alpha globale obtenus directement avec le SDI et les diamètres moyens de la distribution en dimension de la fraction attachée des descendants du radon calculée à partir de la distribution en dimension numérique obtenue au DMPS. On constate que pour nos conditions expérimentales, l'accord est très satisfaisant et que le calcul de l'attachement des descendants du radon à partir d'une distribution en dimension numérique permet de restituer une distribution en dimension tout-à-fait comparable à celle de l'activité alpha globale obtenue avec le SDI.

REFERENCES

- [1] BERTRAND C., BOULAUD D., CHOUARD J.C., GIBAUD C., JANOT M., PINEAU J.F., RICHOU P. - Contrat CCE n° B16 0340-F, 1991
- [2] BOULAUD D., DIOURI M. - J. Aerosol Sci., 19, (7), 927-930, 1988
- [3] BOULAUD D., COMPER C., DIOURI M. - J. Aerosol Sci., 20, (8), 1505-1508, 1989
- [4] TYMEN G. - Thèse d'Etat de la Faculté des Sciences de l'Université de Bretagne Occidentale, Rapport CEA-R-4965, 1979
- [5] WY TY K., KNUTSON E.O. - Aerosol Science and Technology, Vol. 9, n° 1, 71-82, 1988
- [6] PORSTENDORFER J., ROBIG G., AHMED A. - J. Aerosol Sci. Vol. 10, 21-28, 1979.

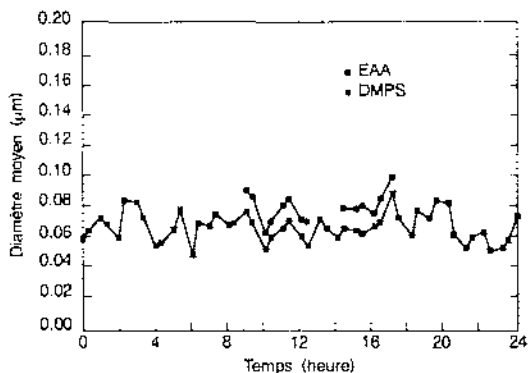

Figure 1 - Variations journalières du diamètre moyen numérique mesuré avec l'EAA et le DMPS

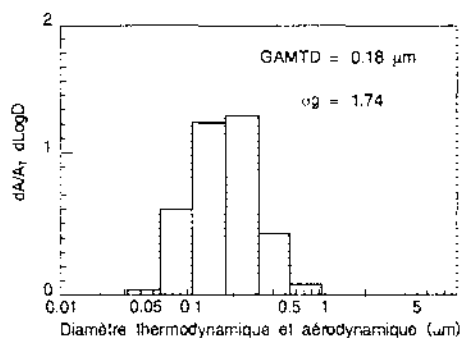

Figure 2 - Exemple d'une distribution en dimension de l'activité alpha globale

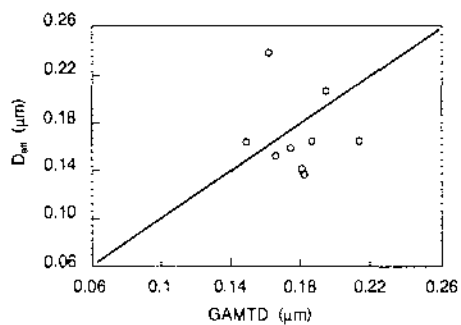

Figure 3 - Comparaison entre le diamètre thermodynamique moyen de l'activité alpha globale (GAMTD) et le diamètre moyen obtenu à partir de la distribution en dimension numérique et du calcul de l'attachement du ^{218}Po (D_{att})

SESSION 7D

Exposition professionnelles -I: installations industrielles

Occupational exposure - I: industrial installations

GESTION DE LA DOSIMETRIE
DES TRAVAILLEURS D'ENTREPRISES EXTERIEURES

Philippe ROLLIN*, Christian LEFAURE**

* EDF - Comité de Radioprotection - Paris

** CEPN (Centre d'Etude sur l'évaluation de la
protection dans le domaine nucléaire) -
Fontenay-aux-Roses

MANAGEMENT OF OCCUPATIONAL EXPOSITION
OF CONTRACTORS' WORKERS

Abstract :

In order to improve the dosimetric follow-up of the contractors' workers and for a fair application of the ALARA principle, EDF has developed a computerized file for occupational doses (collected by electronic dosimeters). Contractors will be associated to the use of the system. In its contracts, EDF is also providing for an improved quality and supervision of the workers' education and training.

I - LE PROBLEME DES TRAVAILLEURS DES ENTREPRISES
EXTERIEURES DANS LE CYCLE ELECTRONUCLEAIRE FRANCAIS

Entre 1985 et 1990, on peut estimer que le bilan de l'exposition collective des travailleurs dans le cycle électronucléaire français est passé de 110 à environ 150 H.Sievert. La part des travailleurs des entreprises extérieures qui était inférieure à 50 % de l'exposition totale en 1985 s'est accrue progressivement pour atteindre près de 70 %, soit environ 100 H.Sievert en 1990.

La quasi-totalité de cette exposition apparaît concentrée dans deux maillons du cycle : les centres de retraitement et les centrales nucléaires. La part de ces dernières est prépondérante dans l'exposition des travailleurs des entreprises extérieures, plus de 90 % en 1990. Cette situation n'est pas surprenante lorsque l'on sait que les travaux de maintenance des réacteurs sont réalisés pour l'essentiel par ces entreprises et que le volume des travaux s'accroît avec le vieillissement du parc (révisions quinquennales, décennales, remplacement de générateurs de vapeur...). Ainsi en 1990, les travailleurs de ces entreprises ont reçu 82 % de l'exposition collective engagée dans les réacteurs à eau pressurisée d'EDF, soit 92 H.Sv sur 113 au total.

En France, du point de vue réglementaire, le contrôle des doses reçues par les travailleurs des entreprises n'est pas du ressort de l'exploitant mais de la responsabilité de leur employeur. Ces contrôles se font par

films dosimétriques mensuels dépouillés par des laboratoires contrôlés par le Ministère de la Santé. Mais l'exploitant n'est pas habilité à connaître les doses, qui sont couvertes par le secret médical et ne peuvent être communiquées qu'à des médecins. Si l'on ajoute à cela les délais de dépouillement de la dosimétrie réglementaire, la mobilité des travailleurs, le rattachement de certaines entreprises à des Services communs de médecine du travail, et il faut le dire la fraude qui peut être le fait d'employeurs peu scrupuleux comme d'ailleurs de travailleurs -surtout intérimaires- plus soucieux de conserver un emploi bien rémunéré que de protéger leur santé, on prend la mesure de la méconnaissance des doses réelles.

Une enquête du CEPN réalisée en 1989 auprès d'un échantillon d'entreprises a permis d'estimer la distribution des doses individuelles des travailleurs extérieurs sur la période 1985-1988. Le pourcentage, d'opérateurs exposés dont la dose annuelle dépasse 15 mSv fluctue entre 25 et 45 % ; celui des opérateurs dont la dose annuelle dépasse 20 mSv fluctue entre 16 et 32 %. Les spécialités concernées par ces fortes doses sont aussi bien celles d'opérateurs très qualifiés amenés à opérer dans des zones pénalisantes (boîtes à eau de générateurs de vapeur) que d'opérateurs beaucoup moins qualifiés comme les calorifugeurs ou les agents de servitudes.

II - MOYENS MIS EN OEUVRE PAR EDF

Face à cette situation préoccupante*, EDF a été conduite à prendre un certain nombre de mesures de sa propre initiative, en dehors du contexte réglementaire ; d'une part afin d'assurer aux travailleurs le même degré de protection qu'à son propre personnel, d'autre part en vue de se doter d'outils lui permettant de mettre en oeuvre une véritable politique d'optimisation de la radioprotection.

Par ailleurs, l'abaissement futur des limites de dose en application de la CIPR 60 (révision de la Directive CCE/EURATOM 80/836) est un motif supplémentaire d'améliorer le suivi dosimétrique des agents d'entreprises extérieures.

EDF a généralisé depuis plus de 10 ans l'usage des dosimètres électroniques. Tout agent -EDF ou entreprise- pénétrant en zone contrôlée en est doté ; la dose est lue automatiquement quand l'agent sort de la zone et lui est affectée par un système informatique. Ceci permet la gestion des doses du personnel fixe de la centrale, et du

* La Commission des Communautés Européennes s'est d'ailleurs saisie du problème au plan européen et a publié une Directive (90/641 EURATOM) pour améliorer la surveillance dosimétrique de ces travailleurs.

personnel d'entreprises pendant son séjour sur un site de centrale. Mais le système est actuellement limité car :

- 1 - la gestion est locale : un travailleur qui change de site repart à zéro ; seules sont contrôlées les doses reçues sur le site (sachant que c'est l'employeur -avec son médecin du travail- qui est responsable du respect des limites annuelles).
- 2 - quand on tente des recoupements avec les résultats obtenus sur plusieurs sites, on se heurte fréquemment au problème de l'identification correcte des travailleurs ; les sources d'erreur sont en effet nombreuses.

Un premier pas vient d'être franchi avec la mise en place d'un *fichier national* (DOSINAT) regroupant les données de dosimétrie opérationnelle*. Ce fichier pourra être interrogé par toutes les centrales. Le système comprend des procédures de contrôle et de validation des identités pour éviter les écueils mentionnés ci-dessus. Ce fichier mis en service en 1992 sur 2 sites pilotes, va être très rapidement étendu à tous les sites.

Mais cette démarche est encore insuffisante. En effet, EDF n'est pas le seul exploitant nucléaire en France. Des contacts ont été pris pour étendre la portée du fichier en y incluant les sites du groupe CEA (Commissariat à l'Energie Atomique).

Ce fichier présente aussi un grand intérêt pour les entreprises prestataires elles-mêmes confrontées au problème de connaître rapidement les doses pour pouvoir gérer leur personnel ; elles sont également sollicitées par leurs clients étrangers pour fournir l'état des doses reçues par les travailleurs et se trouvent souvent dans l'incapacité de le fournir.

III - GENERALISATION DE LA DEMARCHE : L'ASSURANCE DE LA QUALITE - DEVELOPPEMENT DES RELATIONS CONTRACTUELLES

Pour aller plus loin dans la démarche d'optimisation de la radioprotection des travailleurs

* Nota : la dosimétrie opérationnelle ne donne pas nécessairement les mêmes valeurs que la dosimétrie réglementaire par film (seule légale en France), et pourrait être -dans le contexte français- une source de conflits. En fait, il faut comprendre que la dosimétrie opérationnelle restera un moyen de gestion, capable de permettre l'optimisation des doses et d'attirer l'attention sur les travailleurs approchant d'un "niveau d'investigation" à définir avec les services médicaux.

extérieurs, il faut pouvoir compter sur des partenaires industriels sérieux ; les abus liés à l'utilisation d'intérimaires sans formation sont en effet connus.

Pour obtenir des progrès sensibles, il faut un personnel sensibilisé et bien formé. Et cette formation doit être soumise aux règles d'assurance de la qualité, donc contrôlée*. Par ailleurs, l'abaissement des normes de radioprotection va conduire à accroître le nombre des travailleurs pour certains postes plus particulièrement exposés -si des moyens de réduction de doses (robots par exemple) ne peuvent être mis en oeuvre. On ne peut exiger des entreprises cet effort de formation sans leur garantir en contre-partie un volant de travail suffisant même pour les travailleurs ayant atteint un seuil de dose déterminé : ces travailleurs devront être employés en zone non nucléaire. Ceci conduit à développer les relations contractuelles avec les entreprises, ce qui devrait se traduire par une amélioration des conditions de formation et une réduction des doses individuelles.

Les acteurs seront en effet bien identifiés, les temporaires sans formation ne pourront plus être employés pour les travaux les plus exposés ; les clauses contractuelles -avec risque d'exclusion- seront claires sur ce point.

Conclusion :

En résumé, la création d'un fichier national, associant progressivement les principaux exploitants nucléaires français, et auquel auront accès -sous certaines conditions- les entreprises prestataires qui le souhaiteront, devrait permettre de mieux connaître les doses de la plupart des travailleurs et d'assurer correctement leur suivi dosimétrique en temps réel. L'association avec des clauses contractuelles, "moralisant" les relations avec les entreprises, donnant une importance essentielle à l'assurance de la qualité, devrait permettre globalement une meilleure protection des travailleurs extérieurs, objectif conforme aux vœux de la Communauté Européenne. On pourrait en outre souhaiter qu'un fichier communautaire voit rapidement le jour.

* Les moyens prévus dans cette optique sont développés dans la communication n°350 de M. MARILLIER sur le CEFRI.

NUCLEAR POWER IN SWEDEN - DOSES, RELEASES AND ACTIONS

J.Valentin, P.Hofvander, C.Hägg, L.Malmqvist, B.Å.Persson

Swedish Radiation Protection Institute (SSI),
Box 60204, S-104 01 Stockholm, Sweden

ABSTRACT

Some 5,000 workers at 12 units get a mean annual effective dose of 2-3 mSv corresponding to a collective dose of c. 2 man Sv per GW. Annual critical group doses from environmental releases are 0.001-0.015 mSv, public collective doses c. 5 man Sv per GW. A steam generator replacement, 1989, did not change this picture. During the 1980ies, filtered containment venting systems were installed and an organisation for local measurements of gamma dose rate established.

BACKGROUND

The Swedish nuclear programme consists of 12 light water reactors producing about half of the electric power in Sweden. Nuclear power is scheduled for phaseout by 2010, but no starting date is fixed for the phaseout.

The energy availability factor has been in the range of 75-90 %. Some years, utilisation has been about 10 % lower than availability, due to well-filled water reservoirs and low power demand in mild winters. The low annual number of scrams per reactor decreased further in 1990 to 1.7, with no triggered scram at all at 3 reactors. Most scrams originated in conventional systems, not the reactor process system.

THE SYSTEM OF DOSE LIMITATION

Current regulations are based on ICRP 26 (1). However, for workers supplementary dose limits enacted 1989 for age 30 (180 mSv) and lifetime (700 mSv) correspond to a mean of 15 mSv annually. As a level of ambition the annual collective worker dose should not exceed 2 man Sv annually per GW installed capacity. Releases must not cause annual doses exceeding 0.1 mSv to members of critical groups. The annual collective dose should not exceed 5 man Sv per GW installed.

A common centralised dose registration system is operated and used by all nuclear power plants. Internal exposure, checked at the plants by whole-body measurements, has so far been insignificant compared to external exposure.

ANNUAL OCCUPATIONAL EXPOSURES

Data on the nuclear programme and average effective doses are given in Table 1. For individual doses, utility employees have slightly but significantly lower doses than

contractors. No dose since 1981 exceeds 50 mSv per year. Normalised collective doses to staff are consistently in agreement with the regulatory level of ambition, 2 man Sv per year. Internationally, the doses are low, cf. (2).

Table 1. Occupational exposure data at Swedish light water reactors, 1981 - 1990

Year	Number of reactors	Installed capacity (Gw)	Energy generated (Gwa)	Number of exposed workers(a)	Annual individual mean dose (mSv) for utility	Annual individual mean dose (mSv) for contractors	Annual collective dose (man Sv) per reactor	Gwa(b)	Gw(c)
1981	9	6.4	4.5	4,154	2.9	3.3	1.5	3.2	2.1
1982	9	7.3	4.3	3,766	2.3	2.6	1.1	2.3	1.5
1983	10	7.4	4.6	4,774	2.6	3.2	1.5	3.2	2.0
1984	10	7.4	5.8	4,584	2.5	2.5	1.2	2.0	1.6
1985	12	9.5	6.7	4,674	1.8	2.6	0.9	1.7	1.2
1986	12	9.5	8.0	5,688	2.1	3.4	1.4	2.1	1.5
1987	12	9.7	7.7	5,815	1.9	2.9	1.3	2.0	1.5
1988	12	9.7	7.9	5,976	2.2	3.1	1.5	2.2	1.7
1989	12	9.9	7.5	5,449	2.0	3.2	1.3	2.1	1.6
1990	12	10.0	7.4	5,138	2.1	3.1	1.2	1.9	1.4

Notes: (a) Workers with recorded doses only
 (b) Energy generated
 (c) Installed capacity (ambition level: annual collective dose < 2 man Sv)

The steam generators at Ringhals unit 2 were replaced in 1989. The replacement took 72 days and caused a collective dose of only 2.9 man Sv (3). All doses due to this big project are included in Table 1. As can be seen, the project has not changed dose statistics compared to other years.

ACCUMULATED OCCUPATIONAL EXPOSURES

Accumulated effective doses at age 30 are recorded, and predicted lifetime doses shown, in Table 2. Two discriminators were used for lifetime dose prediction: 1) Only workers with a current accumulated dose exceeding 100 mSv were included (their number is given in Table 2), and 2) The dose had to be distributed over 5 or more years.

Lifetime doses were calculated as $E = (D_r + D_c)$, where D_r is the recorded dose during n years including 1990 at the latest, and D_c is the expected dose from 1991 up to age 65 calculated as $D_c = (t * D_r / n)$ where $t =$ years from 1991 to age 65, i.e. with the very conservative assumption of the same average annual dose all years as in past years.

Doses at age 30 have not exceeded the new 180 mSv limit since 1976 (but one foreign contractor was refused to work for this reason in 1991). A score of workers are predicted to hit the lifetime 700 mSv limit, but the prediction is not very realistic. Also, steps taken in response to the limit

Table 2. Accumulated effective dose (E) in mSv at age 30, currently and predicted for lifetime for Swedish nuclear industry workers

Occupational group	Dose at age 30			Current dose	Predicted total lifetime effective dose				
	Number with E >50	E >180	E max	Number with E >100	Number with E >700	E mean	E max	E median	SD E
Health physicists	33	2	222(a)	36	3	430	820	380	163
Mechanical workers	76	2	322(a)	163	17	440	1060	400	183
Service personnel	18	-	136	10	-	410	650	420	160
Insulation personnel	7	-	141	12	1	420	740	410	166
Operation personnel	9	-	148	36	-	330	670	300	124
Material testers	5	-	92	15	-	350	660	310	123
Electr & instr technicians	5	-	97	4	-	320	460	270	105
Chemists	1	-	82	5	-	310	550	240	165
Other staff	18	4	275(a)	37	-	340	660	310	143

Notes: (a) These doses were accumulated before 1976

(b) Total number of workers with recorded dose >0.1 mSv in the underlying central dose register is 27,479

decrease doses further. Although ICRP disfavours lifetime dose limits, the new 100 mSv per 5 years limit (4) will also limit lifetime doses to 900 mSv. Few Swedish workers could accumulate 900 mSv, but several predicted mean lifetime doses exceed 400 mSv, the German lifetime dose limit (5).

EXPOSURES OF THE PUBLIC: RELEASES FROM NORMAL OPERATION

The left part of Figure 1 compares Swedish and international normalised activity releases, excluding air releases of H-3 and all C-14. On average, Swedish BWR releases are similar to other countries, while Swedish PWR releases are smaller than in other countries. The high BWR releases in 1980-1982 are mainly due to fuel damage at the Ringhals BWR unit and at Oskarshamn, causing large noble gas releases.

The right diagram shows effective doses to critical groups from Swedish plants including H-3 and C-14. All doses are far lower than the limit, 0.1 mSv. However, 3 of the 4 Ringhals units are PWRs, all other Swedish units are BWR. While PWR releases are smaller, PWR doses are higher, mainly due to lower smoke stacks causing a higher C-14 dose.

C-14 dominates the collective dose. Using a truncated 500-year time integral, the calculated C-14 collective dose is c. 48 man Sv annually, or up to c. 1.2 times the level of ambition of 5 man Sv per GW. All other releases together

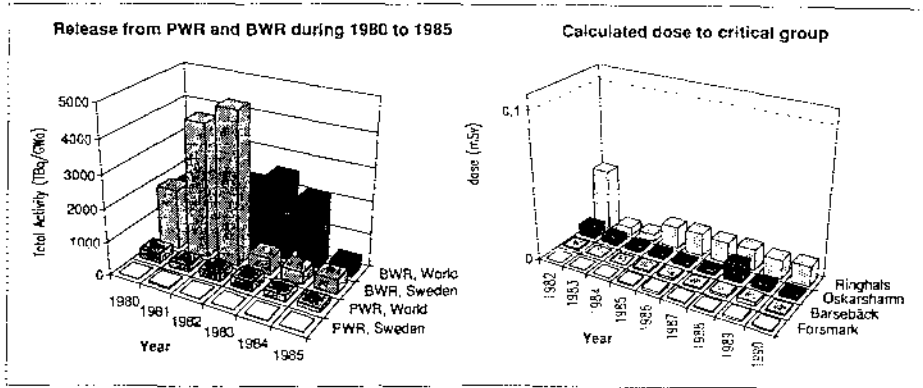

give less than 0.1 man Sv.

EMERGENCY PREPAREDNESS

Since 1981, an extensive programme has introduced mitigating devices and a new severe accident handling strategy at the plants. For each reactor containment, filtered venting systems can be activated manually or automatically, in order to avoid heavy ground contamination even in severe accidents. There is a regulatory limit on accident releases through the filter of 0.1 % of the core inventory of particulate activity, normalised to an 1800 MW (thermal) reactor.

After Chernobyl, all counties and all 284 urban and rural districts in Sweden were equipped with gamma dose rate instruments with a range of 0.1 uSv/h to 10 mSv/h. Some 500 persons have been taught to use these and measurements are practiced at 7-month intervals at about 800 local reference points. Thus reference data with seasonal variations are obtained and handling proficiency retained. This supplements other means of rapid determination of radiation conditions. It would provide an important background for information to the public in accidental fallout situations.

REFERENCES

1. ICRP, 1977. Recommendations, ICRP Publ. 26. Annals of the ICRP 1(3).
2. Wood, C.J., 1991. Getting exposures down at US plants. Nucl. Eng. International, May, 16-18.
3. Looft, H., 1990. Ringhals replacement project sets new standards. Nucl. Eng. International, January, 20-28.
4. ICRP, 1990. Recommendations, ICRP Publ. 60. Annals of the ICRP 21(1-3).
5. Kaul, A. et al, 1989. Limitation of occupational radiation risk by radiation protection legislation in the Federal Republic of Germany. J. Radiol. Prot. 9, 85-92.

SAFETY STATUS OF RADIATION WORKERS HANDLING RADIOLUMINOUS PAINT

P.K.Gaur, Geetha Sadagopan, G.Venkataraman &
*Kamala Rudran

Division Of Radiological Protection

*Health Physics Division

Bhabha Atomic Research Centre,

Trombay, Bombay-400 085

ABSTRACT

Staff handling Radioluminous Paint (RLP) have been monitored for internal burden for the past ten years. The annual collective dose equivalent is found to vary from 20 to 268 man mSv in case of ^3H . The collective dose per TBq activity of ^3H is ranging from 0.54 to 7.72 man mSv. In case of ^{147}Pm the bioassay results indicated pulmonary burden in some of the workers. The effective dose equivalent is found below 0.1 mSv.

INTRODUCTION

Use of RLP in the country in past seven years has increased from 37 to 185 TBq in case of ^3H paint and 2 to 3.7 TBq in case of ^{147}Pm . Watch manufacturers import ^3H paint with specific activity varying from 0.07 to 18.5 TBq/kg. ^{147}Pm paint is manufactured in the country with specific activity of 70 GBq/kg. There are sixteen institutions actively using RLP with a work force of 100. These institutions use RLP in large quantity. At one place the paint is used in powder form. Their workplaces were routinely inspected and modified to reduce air, surface and personnel contamination. The luminizing jobs are now done in ventilated boxes (VB) & glove boxes (GB) installed in a ventilated room⁽¹⁾. Workers engaged in luminizing job, work with RLP in rotation for fixed interval of time varying from 15 to 90 days. The workers engaged in painting job are monitored continuously for internal burden.

METHOD/PROCEDURE OF MONITORING

Tritium concentration in air as HTO is measured by cold strip method and total tritium using continuous tritium monitor⁽²⁾. To remove tritium in particulate form, air was filtered through absolute filter paper and counted for ^3H concentration. ^3H workers are monitored before commencement and soon after stopping the work with RLP. ^3H burden is estimated by urine analysis, by taking biological half life $T_b=7$ days or actual T_b of the workers. The urine samples from outstation institutions are received by post at regular intervals. ^{147}Pm concentration present in particulate form in air is measured by filtering large volume of air through absolute filter paper and counting ^{147}Pm betas on it with a calibrated end window type GM counter. ^{147}Pm workers are called to Trombay for monitoring once in a year soon after stopping the work with RLP. ^{147}Pm body burden is measured by estimating activity in liver using Phoswich Detector⁽³⁾ (counting the bremsstrahlung) and also by carrying

out bioassay. RLP workers have been monitored continuously over a period of 10 years.

RESULTS AND DISCUSSION

Regular personnel monitoring, periodic inspection of the workplaces and modifications carried out in working areas have resulted in a significant reduction of annual dose to radiation workers. In institution 'A' where the luminizing operation is dusty, the annual Dose Equivalent (ADE) in the year 1981-82, was in the range 8.2 to 16.2 mSv, is now, in the range 0.07 to 3.5 mSv (Table I). The use of GB/VB for luminizing job and the improvement in ventilation system to create 5 to 12 air changes in the workshop was recommended. This change has brought down the HTO concentration during working hours to 40 kBq/m³ from 1200 kBq/m³ of air. A worker in this air concentration would receive ADE of about 2.5 mSv. It can be seen in the table I that in most of the workers, the ADE in 1988 is less than 3 mSv. During the monitoring programme, ³H concentration in urine samples indicated the concentration varying from 3.7 to 370 kBq/l of urine. There were instances when ³H concentration in few workers exceeded the level of 370 kBq/l of urine. The maximum ³H concentration in urine which was detected at any time in any subject was 2.5 MBq/l of urine. The investigations revealed that the ventilation system was not operative during the period of higher internal burden. It was evaluated that with the ventilation system OFF, the HTO concentration can rise to 330-370 kBq/m³ of air⁽⁴⁾. This may increase the urine concentration by a factor of ten. In institution 'B' large quantity of RLP (92.5 TBq) with specific activity 18 TBq/kg is in use and is currently being modified. The monitoring programme was started in 1987 and systematic studies were initiated in 1988. The ADE in these workers ranged from 4.35 to 23.53 mSv (Table II). In 1990 the ADE received by most of the workers was in the range of 0-10 mSv whereas in 1988-89, it was 10 to 20 mSv. Here HTO concentration in urine was usually in the range of 10 to 100 kBq/l. There were also instances when HTO concentration was higher than the usual level. In two cases the levels were estimated to be 2.58 & 3.8 MBq/l. Air monitoring results showed HTO concentration at this place to be in the range of 101 to 210 kBq/m³ of air. This contamination also has

Table I: Distribution of annual dose equivalent in mSv in institution 'A'.

Range	Number of Workers							
	1981	1982	1983	1984	1985	1986	1987	1988
0-3.0	0	0	7	10	10	9	8	8
3.1-4.0	0	1	1	0	0	2	1	1
4.1-5.0	0	0	0	0	0	0	1	0
5.1-10.0	2	1	1	0	0	0	1	0
11.0-20.0	2	4	0	0	0	0	0	0
Above 21	0	0	0	0	0	1(EE)	0	0

Table II: Distribution of annual dose equivalent in mSv in institution 'B'.

Range	Number of workers		
	1988	1989	1990
0-10	2	3	15
11-20	3	11	8
21-30	0	2	1
Above 31	0	0	1 (EE)

EE- excessive exposure (annual dose equivalent more than 50 mSv)

Table III: Level of fecal activity detected.

Range of act. Bq/24 h	0-1.0	1.0-2.0	2.0-3.0	3.0-4.0	4.0-5.0
No. of workers	8	1	1	2	2

been brought down by improving ventilation system and use of GB/VB. This relatively higher internal burden in these workers is probably due to two reasons. Firstly, the period of rotation is as long as 90 days. Secondly, the quantity and the specific activity of paint used is large.

Whole body counting of ^{147}Pm did not show any liver burden in workers. However fecal analysis indicated some activity in a few workers. Activity was not detected in any urine sample. Repeat measurements after five days did not show reduction in fecal activity. Lung burden was evaluated from fecal activity assuming $T_b=500$ days in lung. It was found to range from 0.4 to 5.2 kBq (Table III). In all other cases the pulmonary burden was below the detection limit of the counting set-up which is 0.89 kBq. The ^{147}Pm paint supplied to the institutions is an oxide compound which is insoluble in body fluid. The activity in fecal samples is the activity which is being eliminated from the lung. In most of the cases the exact date of intake is not known, as they reported for monitoring very late after stopping the work with paint. After the improvement in ventilation system the air concentration is 1.2 MBq/m^3 . Some times when the room is dry swept, the air contamination rises to a level of 2.3 MBq/m^3 , higher than DAC for ^{147}Pm (2 kBq/m^3).

CONCLUSION

Use of RLP in the country is safe. The internal burden in the workers is well within the limit provided the radiation safety procedures are followed. There are about 76 workers engaged in tritium work and collective dose evaluated from monitoring data of two institutions works out to be 20 and 268

man mSv. There were two cases of excessive exposure due to ^3H . In one subject it was 120 mSv and in the other it was 210 mSv. However these workers were laid off from the radiation job. The annual internal dose received per person due to ^3H in year 1988 was 0.24 mSv which is one eighth of the annual dose received per year in USA(5). In 1989 it was 3.5 mSv. The main contribution is due to institution 'B' which is under modification. In case of ^{147}Pm paint, the number of workers are less and have insignificant lung burden. The collective dose is much less. Internal burden can further be brought down by improving the ventilation system as per the activity handled and allotting the painting job in rotation to workers. Surface contamination was observed in all the workplaces, therefore cleanliness and periodic decontamination of the workplace will also reduce the annual dose to workers. No liver burden was observed in recent years, but in 1982 there were three cases with liver burden ranging between 10.7 to 27.4 kBq(6). ^{147}Pm workers receive external exposure mainly due to bremsstrahlung but well within the limit. These results will be presented separately.()

ACKNOWLEDGEMENT

Authors gratefully acknowledge the help given by Dr. R.C.Sharma, Head of the Internal Monitoring Section of Health Physics Division in providing the Whole Body Monitoring results from 1980 and sincere thanks are due to Mr. M.Rathnakaran of Environment Assessment Division for loaning the tritium monitor.

REFERENCES

1. I.L.O., 1964, Guide on Protection Against Ionising Radiations in the Application of Luminous Compounds, Manual of Industrial Radiation Protection, Part V, International Labour Office, Geneva.
2. Rathnakaran M, 1982, Portable Tritium Monitor for Measurement of Tritium in Water Vapour Form (HTO) in Presence of Other Interfering Radiations. Bulletin of Radiation Protection, 5, pp 33-38.
3. Sharma R.C.et al.,1975, Assesment of Chest Burdens of Plutonium, Vienna, IAEA-SR-/50
4. Gaur P.K. and Venkateswaran T.V., 1986, Radiation Safety In Radioluminous Paint Workshop Handling Tritium Activated Paint, Bulletin of Radiation Protection, 9, pp 13-17.
5. Robert E.S. et al, 1983, Occupational Exposure To Dial Painters And Assemblers Of Radioluminous Timepieces, Health Physics, 44, pp 501-506.
6. Venkateswaran T.V. et al, 1984, Proc. of VI International Congress of the International Radiation Protection Association, Berlin, May 7-12, pp 824-827.

---000---

" IMPACT DU COMBUSTIBLE MOX
SUR LA DOSIMETRIE PROFESSIONNELLE "

---000---

" IMPACT OF MOX FUEL
ON PROFESSIONAL RADIATION EXPOSURE "

---000---

Alain GLOAGUEN
Electricité De France
Direction Production Transport
Service des Combustibles
23 bis, avenue de Messine
75384 - Paris - FRANCE
Tel : 40.42.23.79
Fax : 40.42.56.92

Christian THEZEE
Electricité De France
Centre de Production Nucléaire
de Saint-Laurent-des-Eaux
B. P. 42
41220 - La Ferté-Saint-Cyr - FRANCE
Tel : 54.44.84.84
Fax : 54.44.84.00

---000---

The plutonium recycling in LWR was adopted by several european countries right from the early 70's. At that time, France elected to develop the breeders. Some years later, when the economic conditions led to postpone the building of breeders, recycling in PWR was decided in France.

MOX fuel was introduced firstly in Saint-Laurent-des-Eaux 900MWe reactor (unit 1) as an industrial product. Since five reactors are dedicated to plutonium recycling; the core management scheme consists of reloads containing 16 MOX fuel (i. e. a third of the renewed assemblies). Sixteen PWR units are authorized to such a recycling and could be used by the year 1997.

As far as radioprotection is concerned, the fresh MOX fuel emits neutron and gamma rays when enriched uranium fuel emission is almost negligible.

In files established to obtain a generic authorization for MOX use it has been demonstrated that the collective doses corresponding to the complete fuel cycle were quite similar for MOX and for enriched uranium fuel. This fact has been confirmed by experience; MOX fuel fabrication and handling do not induce penalty in comparison with uranium mining and implementation.

To reduce doses for operators in the EDF power plants, a new handling system of fresh fuel has been conceived. the controls concerning fresh fuel receipt have been modified to make shorter the operator exposition time and screens are used to decrease the level of radiations.

---000---

Dès le début des années 1970, plusieurs pays européens optaient pour le recyclage du plutonium dans les réacteurs à eau légère. La France, en choisissant le développement des réacteurs surrégénérateurs, trouvait là une voie d'utilisation du plutonium issu des usines de retraitement provenant des Réacteurs à Eau sous Pression (REP) et des réacteurs de la filière Uranium Naturel Graphite Gaz (UNGG). L'évolution différée de la filière des réacteurs surrégénérateurs a conduit la France en 1985 à s'engager dans la voie du recyclage du plutonium dans les réacteurs REP. Cette possibilité avait été prise en compte dès la conception du palier REP 900 MW, tant sur le plan technique qu'administratif. Seize tranches REP 900 MW sont actuellement disponibles pour ce type de fonctionnement. Dans l'avenir, 12 tranches REP 900 MW et quelques tranches REP 1300 MW pourraient compléter ce parc. La première tranche REP 900 MW a été chargée en 1987 et aujourd'hui, cinq tranches fonctionnent de manière industrielle en cycle mixte, selon une stratégie de rechargement par tiers de coeur. Deux de ces tranches ont un coeur à l'équilibre. La stratégie de rechargement par tiers de coeur conduit à renouveler le tiers des éléments combustibles lors de chaque campagne, en les remplaçant, en cycle mixte par un tiers de combustible MOX (4,5 % de PU) et deux tiers de combustible standard (3,25 % d'U5). Les irradiations de décharge des lots de combustible sont de l'ordre de 33.000 MWj/t, ce qui correspond à 300 JEPP.

Le tableau qui suit donne le bilan comparatif de la dosimétrie engagée selon les deux voies, combustible standard (cycle UO₂) et combustible mixte (cycle MOX).

POSTES	CYCLE UO ₂	CYCLE MOX	
	en mSv / tonne de combustible		
Mine	57,27		
Concentration	3,06		
Conversion UF ₄	1,76		
Conversion UF ₆	0,20		
Enrichissement	faible	40,00	*
Transport PU		0,20	
Fabrication	25,00	40,00	
Transport Assemblages		0,13	
Réacteur	87,00	90,10	
Retraitement	16,40	19,70	
BILAN TOTAL	190,69	190,13	

* Ce chiffre résulte:

- du coût dosimétrique de l'extraction d'uranium naturel,
- et d'une part du coût dosimétrique du retraitement pour le plutonium.

Avant d'analyser les chiffres présentés dans ce tableau, un rappel élémentaire des données radiologiques s'impose.

Le combustible standard est constitué d'uranium enrichi à 3,25 %. Provenant directement de l'uranium naturel,

Le MOX est actuellement fabriqué à partir de plutonium provenant du retraitement du combustible UNGG. Sa composition isotopique évoluera donc lorsqu'il sera utilisé en aval du retraitement du combustible REP. Enfin le MOX est actuellement élaboré à partir d'uranium naturel appauvri lors du processus d'enrichissement (et non d'uranium de retraitement).

Le Plutonium sous ses différentes formes isotopiques :

- est un émetteur alpha. Il émet 10 à 100 fois plus de rayonnement alpha que l'uranium,
- est un émetteur bêta par l'intermédiaire de l'isotope 241 lors de sa désintégration en américium,
- est un émetteur gamma par la présence d'américium 241 provenant de la désintégration du plutonium 241,
- et est enfin un émetteur neutron par les fissions spontanées de la plupart des isotopes ou par les conséquences des réactions nucléaires qui se produisent lorsque des atomes d'éléments plus légers sont bombardés par des particules alpha de haute énergie (provenant par exemple du plutonium 238 et plutonium 240).

Les rayonnements alpha et bêta ne sont nocifs que lorsque le plutonium s'introduit dans le corps humain, ceci ne concernant que les situations accidentelles d'inélançabilité de stockage qui ne sont pas traitées dans cet exposé. En fin de cycle (33.000 MWj/t) le Mox ne se distingue pas significativement du combustible standard qui contient alors 1% de plutonium provenant de la transformation de l'Uranium 238.

Les émissions de rayonnements gamma ou neutrons obligent à prévoir

- une protection physique supplémentaire à certains stades du processus industriel,
- une automatisation ou des techniques d'examen ou de maintenance adaptées afin de limiter les temps d'exposition.

Il ressort donc, malgré les incertitudes entachant les valeurs présentées, que les doses collectives engagées par tonne de combustible irradié sont du même ordre de grandeur pour les deux cycles de combustible.

Les doses intégrées dans les réacteurs et les usines de retraitement sont voisines pour les deux types de combustible.

Les doses plus importantes dans les usines de fabrication du combustible MOX, relativement aux usines de fabrication du combustible standard, sont compensées par les doses économisées dans les mines et les usines de conversion.

Si l'on fait abstraction de l'enrichissement pris ici au titre du retraitement du combustible standard irradié, le bilan dosimétrique pour le MOX s'établit à 150 mSv par tonne de combustible. L'analyse des écarts par rapport au cycle du combustible standard fait apparaître des postes en augmentation. Ce sont les étapes de fabrication, d'exploitation en réacteur et de retraitement (toutes activités confondues).

La fabrication de ce combustible se fait actuellement dans l'usine BELGO-NUCLEAIRE située à DESSEL en BELGIQUE. Cette usine ne pouvant assurer la fabrication de la quantité de combustible suffisante, sera à terme relayée par l'usine française MELOX implantée à MARCOULE. On peut considérer que les chiffres de dosimétrie ne changeront pas de manière significative dans la mesure où deux paramètres agiront de manière antagoniste. Cette usine mettra en oeuvre un processus de fabrication qui diminuera le bilan dosimétrique, cependant, il est probable que la dégradation qualitative du plutonium de retraitement (augmentation du burn-up) réduira les gains escomptés.

S'agissant de la phase d'exploitation en réacteur, l'écart peu significatif (3 mSv par tonne de combustible) a pour principale origine la manutention du combustible MOX en centrale nucléaire lors de sa réception. Le combustible MOX est livré par transport routier spécial, accompagné. Deux livraisons sont nécessaires pour un rechargement du coeur (16 éléments MOX). Chaque livraison comprend en général quatre containers renfermant chacun deux éléments combustibles. Chaque container est instrumenté afin de mesurer avant son ouverture l'éventuelle occurrence de chocs lors du transport. L'effectif du personnel présent lors des opérations de réception est limité à 8 personnes. Des contrôles dosimétriques gamma et neutrons sont effectués sur le container avant l'ouverture. Après ouverture, un contrôle dosimétrique gamma et neutron est effectué au contact des éléments combustibles MOX. Les éléments combustibles sont ensuite basculés en position verticale et manutentionnés un à un, afin de réaliser une opération de contrôle élémentaire avant l'immersion en piscine. Un poste d'examen a spécialement été conçu afin que tout le chemin effectué par l'élément combustible ne se fasse pas à une hauteur supérieure à 70 cm (2,3 feet). Cette disposition permet de prévenir les risques en cas de chute de l'élément combustible. Le contrôle élémentaire a pour seul objectif de s'assurer qu'aucun corps étranger ne se trouve entre les crayons combustibles. Les contrôles de qualité et dimensionnels sont effectués en usine de fabrication du combustible, cette stratégie étant validée par les résultats. Le poste d'examen en centrale nucléaire est blindé afin de réduire les effets des rayonnements gamma et neutrons. Il est équipé d'un poste d'observation optique par binoculaire et miroirs coulissant de bas en haut afin d'examiner les quatre faces de l'élément combustible. Après ce contrôle, l'élément combustible MOX est immergé en piscine avant son transfert dans le coeur du réacteur. Le stockage sec est exclu.

La phase complète d'ouverture d'un container, de contrôle, et d'immersion des deux éléments combustibles MOX dure en moyenne xx minutes.

Les appareils de mesure utilisés par Electricité de France pour ces opérations sont :

- le compteur FAG FH 40 (SOCIETE NARDEUX) pour le débit de dose gamma,

- le compteur DINEUTRON (SOCIETE NARDEUX) pour le débit de dose neutron. Ce compteur effectue directement la conversion neutron-gamma sur la base de la courbe de la CIPR (gamme d'énergie de 0,025 ev à 15 Méga ev).

Seize réceptions de combustible ont déjà été réalisées dans la centrale nucléaire de Saint-Laurent-des-Maux. la valeur moyenne des doses mesurées est de 3,3 mSv par tonne de combustible.

Le retraitement enfin fait apparaître un bilan dosimétrique plus fort en ce qui concerne le MOX. Cet aspect est directement lié à la composition du combustible MOX en fin de cycle. Le combustible MOX contient, à burn-up égal (33.000 MWj par tonne) 4 % de plutonium, alors que le combustible standard ne renferme que 1 % de plutonium. Les deux pourcentages cités étant à pondérer dans leurs effets radiologiques par la composition isotopique qui est défavorable pour le MOX.

Le dossier de faisabilité établissait que les doses collectives par tonne de combustible chargé en réacteur, pour le combustible standard à l'uranium enrichi et pour le MOX, devaient être comparables. L'expérience acquise confirme donc ce point. Les doses résultant de la fabrication du MOX en usine et de sa manutention en centrales nucléaires sont compensées par les doses liées à l'extraction et à la conversion de l'uranium naturel.

---000---

SPECIFICATIONS DE BLINDAGE PRIMAIRE ET SECONDAIRE POUR
LES SALLES DE RADIOGRAPHIE INDUSTRIELLE MUNIES
D'IRIDIUM 192 SELON LES LIMITES DE DOSES
EFFECTIVES ANNUELLES D'ICRP 60

Jean-Marc Légaré

Ministère de l'Environnement du Québec,
6072 est, rue Sherbrooke
Montréal, Québec, Canada H1N 1C1

PRIMARY AND SECONDARY SHIELDING SPECIFICATIONS FOR INDUSTRIAL
RADIOGRAPHY ROOMS WITH IRIDIUM 192 ACCORDING TO ICRP 60
ANNUAL EFFECTIVE DOSE LIMITS

The correlation between the HVL of large fields coming out of various shielding thicknesses of exposure rate transmission curves and the conversion coefficients [Effective dose equivalent/100 Exposure] for an AP anthropomorphic phantom (ICRP 51, 1987) is first determined. These factors are then applied to free air primary, scatter and leakage exposure dose rates and transmission fractions for lead, steel and concrete. The results are then used to obtain the table of shielding specifications for primary, scatter and scatter with 0,1% 1% and 10% leakage for various distances and weekly workloads to meet the average yearly effective dose limits of 20 and 1 mSv per year of ICRP 60 (1991).

INTRODUCTION

Le but de ce travail est d'établir les spécifications de blindage pour l'iridium 192 afin de rencontrer les limites de doses effectives annuelles moyennes de 20 et 1 mSv par année de ICRP 60 (3) pour l'exposition AP d'un mannequin selon ICRP 51 (2).

PROCÉDURE

La procédure utilisée est la suivante:

1. Faire sur la figure ci-jointe le graphique des CDA expérimentales de plomb, d'acier et de béton pour des grands champs très filtrés en fonction de l'énergie équivalente des rayons (4, 5 et 7). Ajouter sur cette figure le graphique de la fraction [Equivalent de dose effective en Sv/100 Exposition en R] d'un mannequin AP selon ICRP 51 (2). Ceci nous donne donc les facteurs de conversion [EDE/100 Expos.] pour diverses CDA à la sortie de diverses épaisseurs de blindage présélectionnées sur toute courbe de transmission.
2. Choisir une charge de travail hebdomadaire donnée de 4800 Ci h (640 000 TBq s) par semaine pour l'iridium 192 et calculer à 1,0 m de distance pour ces épaisseurs de blindage présélectionnées, les produits [Débit d'exposition primaire de 500 mR/h Ci (7) ou diffusé de 22 mR/h Ci x Fraction d'exposition primaire (1) ou diffusée (6)] pour le plomb, l'acier ou le béton selon l'épaisseur de blindage présélectionnée x

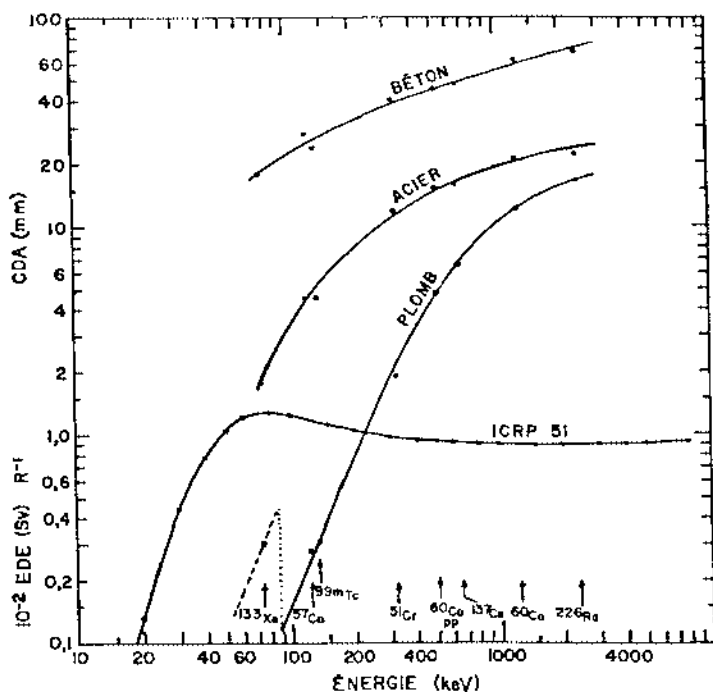

Figure - Couches de demi-atténuation (CDA) de grands champs traversant le plomb, l'acier et le béton (4 et 7) en fonction de l'énergie équivalente d'exposition (5); coefficients de conversion [Equivalent de dose effective/100 Exposition] de grands champs sur un mannequin AP (2) en fonction de l'énergie (keV). L'EDE s'appelle maintenant la dose effective E (3).

Facteur de conversion [EDE/100 Expos.] pour les CDA au-delà des épaisseurs de blindage présélectionnées. On a fait les mesures au moyen de compteurs Berthold LB 1200 et Keithley 36150 étalonnés par sources radioactives (5). Les rayons diffusés à 90° avec l'axe central provenaient d'un mur de béton exposé à 45° alors que les rayons diffusés à 95° avec l'axe central provenaient du plancher de béton exposé perpendiculairement. La moyenne des rapports des débits d'exposition [diffusé (2 m)/ primaire (2 m)] était de 0,044 pour le cône de 60°, soit 1,7 fois le résultat d'un cône de 46° utilisé dans un autre projet relié aux expositions (6).

3. Faire pour chaque matériau, une figure de courbes de ces valeurs mSv/sem. en fonction de l'épaisseur des matériaux.
4. Répéter l'étape 2 pour les rayons de fuites dont les CDA s'obtiennent pour chaque épaisseur de blindage donnant 10%, 1% ou 0,1%, ajoutée des épaisseurs présélectionnées.
5. Additionner, pour chaque épaisseur présélectionnée, les équivalents de doses effectives par semaine de diffusion de l'étape 2 et de fuites (10% 1% ou 0,1%) de l'étape 4. Ajouter ces trois lignes sur la figure (non illustrée).

Spécifications de blindage pour l'iridium 192 pour réduire les doses effectives primaires, secondaires et diffusés à 90°-95°, à 0,40 et 0,02 mSv par semaine (20 et 1 mSv/année)

Irc 5 sem.	Ci h sem.	Distance source - point d'intérêt (m)									
		1,0	1,4	2,0	2,8	4,0	5,7	8,0	11,3	16,0	
640 000	4 800										
320 000	2 400										
160 000	1 200										
80 000	600										
40 000	300										
20 000	150										
10 000	75										
5 000	38										
2 500	19										
mSv/sem	Matériau	Épaisseur de blindage (mm)									
		Primaire									
0,40	Piom b	81	75	70	64	57	52	45	40	35	
0,02	Piom b	105	100	94	88	82	77	71	66	59	
0,40	Acier	265	193	180	168	155	143	130	118	105	
0,02	Acier	259	247	234	223	210	197	185	172	159	
0,40	Béton	710	668	627	583	540	500	450	415	374	
0,02	Béton	893	850	810	764	725	687	636	595	554	
mSv/sem	Matériau	Secondaire: 10% fuites avec diffusion (cône 60°)									
0,40	Piom b	68	62	57	51	45	39	33	27	22	
0,02	Piom b	92	87	81	75	70	64	58	52	47	
0,40	Acier	155	144	131	120	107	94	83	70	58	
0,02	Acier	210	197	184	173	160	147	135	124	110	
0,40	Béton	530	486	448	404	364	321	283	245	206	
0,02	Béton	714	671	630	583	544	501	458	414	379	
mSv/sem	Matériau	Secondaire: 1% fuites avec diffusion (cône 60°)									
0,40	Piom b	53	47	42	36	30	23	18	13	7	
0,02	Piom b	77	72	66	60	55	49	43	37	32	
0,40	Acier	118	107	96	85	74	63	53	43	34	
0,02	Acier	170	158	146	134	123	110	100	89	77	
0,40	Béton	420	387	350	313	277	240	207	170	140	
0,02	Béton	589	550	510	470	432	395	359	321	288	
mSv/sem	Matériau	Secondaire: 0,1% fuites avec diffusion (cône 60°)									
0,40	Piom b	33	28	23	18	13	9	7	5	3	
0,02	Piom b	58	52	46	41	35	29	24	19	14	
0,40	Acier	107	97	84	74	65	55	46	38	29	
0,02	Acier	145	135	125	115	105	95	86	77	67	
0,40	Béton	393	368	323	291	256	225	192	160	127	
0,02	Béton	537	502	468	432	401	367	332	300	266	
mSv/sem	Matériau	Diffusion (cône 60°: diff. = 0,044 prim.)									
0,40	Piom b	16	14	13	11	9	7	5	4	3	
0,02	Piom b	24	22	20	19	17	15	13	11	9	
0,40	Acier	99	90	81	72	63	55	46	38	29	
0,02	Acier	136	128	119	110	102	93	84	75	66	
0,40	Béton	386	352	320	288	253	224	191	160	127	
0,02	Béton	528	496	461	428	397	364	330	297	265	

6. Lire, pour chacune de ces cinq courbes pour un matériau donné, les épaisseurs de blindage donnant 0,40 et 0,02 uSv par semaine à 1,0 m de distance et le double de uSv par semaine à chaque multiple de $\sqrt{2}$ m de distance.
7. Inscrire ces épaisseurs de chaque matériau dans le tableau ci-joint des spécifications de blindage puisque sur une base de 50 semaines de travail par année, elles correspondent aux limites de doses effectives annuelles moyennes de 20 et de 1 mSv/année de ICRP 60 (3) pour le mannequin AP (2).

DISCUSSION

Les facteurs de conversion [EDE/100 Expos.] trouvés et utilisés dans ce travail sont pour les courbes primaires de plomb, d'acier et de béton successivement de 0,92-0,96 0,90-0,93 et 0,89-0,95 selon l'épaisseur de matériau. Pour les rayons diffusés, elles sont 0,97-1,09 0,99 et 0,92-1,05. La procédure utilisant la figure ci-jointe peut s'appliquer dans l'obtention des spécifications de blindage pour rencontrer les valeurs d'ICRP 60 (3) pour le mannequin, tant pour les rayons X que pour les sources radioactives si les données d'exposition (ionisation) de base sont adéquates. Dans l'utilisation du tableau, il y a lieu d'inclure un facteur de sécurité surtout lorsqu'on utilise de grandes épaisseurs de blindage en raison des extrapolations dans les données utilisées (1 et 6). Dans le cas de la courbe de transmission primaire à travers le plomb utilisée (1), elle est plus exigeante qu'en 1958 (8). Quant aux installations sans plafond, on peut trouver ailleurs (6) des données utiles sur l'effet de ciel (skyskine) et sur le blindage (hauteur x épaisseur) optimal pour l'iridium 192 et le cobalt 60.

BIBLIOGRAPHIE

1. ICRP Publications 15 and 21, Pergamon Press, Oxford, 141 p., 1976 et 1978, ISBN 0-08-02 0906-8
2. ICRP Publication 51, Pergamon Press, Oxford, 135 p., 1987 ISBN 0 08 035587 0 et ISBN 0146-6453
3. ICRP Publication 60, 1990; Ann. ICRP 21 (1-3)), 201 p. Pergamon Press, Oxford, 1991
4. Légaré J.-M. et Carrière P.-E., Radioprotection, 23, 367-379, 1988
5. Légaré J.-M., Ministère de l'Environnement du Québec 22 p., 1990, ISBN 2-550-20797-1, Envirodoq 900030 QEN/EN-26/1. Gratis.
6. Légaré J.-M. et Aubé B. Ministère de l'Environnement du Québec, approx. 80 p., 1992
7. NCRP Report Nr. 49, 126 p., 1976, Washington, D. C.
8. Ritz V. H., Nondestructive Testing 16, 269-272, 1958

**RETROSPECTIVE ANALYSIS OF THE EVOLUTION OF
THE PWRs OCCUPATIONAL EXPOSURE**

Marie BENEDITTINI* - Alain BRITSAUD** - Jean-Luc TROMBINI***

(*) CEPN, BP 48, 92263 Fontenay-aux-Roses Cedex - France

(**) EDF/SEPTEN, 12-14 av Dutriévoz, 69629 Villeurbanne Cedex - France

(***) EDF/DSRE, BP 114, 93203 Saint-Denis Cedex 1

ABSTRACT

The communication presents the main evolutions of the collective and individual exposures within pressurized water reactors. Results are based on the analysis of a database developed at CEPN since 1986 for Electricité de France including about 1 100 reactor-years in nine countries. So far the impact of new reactors integrating the benefit of past experience and improvement in exposure-control has balanced the tendency to increasing doses associated with the ageing of installations. This evolution will only remain if on-going efforts to control and reduce exposures are strengthened.

**ANALYSE RETROSPECTIVE DE L'EXPOSITION PROFESSIONNELLE
DANS LES REACTEURS A EAU PRESSURISEE**

I - LA BASE DE DONNEES

Depuis 1986, à la demande d'Electricité de France, le CEPN développe une base de données, mise à jour annuellement, sur l'exposition professionnelle dans les réacteurs à eau pressurisée (REP). Cette base intègre les réacteurs mis en exploitation depuis juillet 1974 dans les neuf pays suivants : Belgique, Espagne, Etats-Unis, Finlande, France, Japon, République Fédérale d'Allemagne, Suisse et Suède. Au total, en prenant en compte les données relatives à 1989, la base contient 147 réacteurs, ce qui représente une expérience de près de 1 100 années réacteurs.

Le Tableau 1 présente les principales caractéristiques des réacteurs introduits dans la base de données pour les différents pays. Les parcs des Etats-Unis et de France sont les plus importants et représentent respectivement 37 % et 33 % du nombre total de réacteurs de la base, et 38 % et 34 % de la puissance totale installée. Les parcs les plus jeunes sont ceux de l'Espagne et de la France ; les plus anciens ceux de la Finlande et de la Suisse.

Tableau 1 : Caractéristiques des parcs REP en exploitation en 1989 pris en compte dans la base de données.

PAYS	Nombre de réacteurs	Puissance électrique (GW _e)	Nombre d'années d'exploitation (ans)	Age moyen (ans)
Belgique	7	5,8	65	9,3
Espagne	6	5,7	27	4,5
Finlande	2	0,9	22	11
France	48	50,3	297	6,2
Japon	14	11,5	126	9
R.F.A	11	13,9	78	7,1
Suède	3	2,8	29	9,7
Suisse	1	1	10	10
USA	55	57	442	8
Ensemble	147	149	1096	7,5

II - L'EVOLUTION DE L'EXPOSITION COLLECTIVE

La **Figure 1** qui présente l'évolution depuis 1975 de la dose collective moyenne par réacteur, montre une réduction régulière de cette dose entre 1982 et 1988 et une légère remontée des valeurs en 1989 avec des résultats comparables à ceux de 1987.

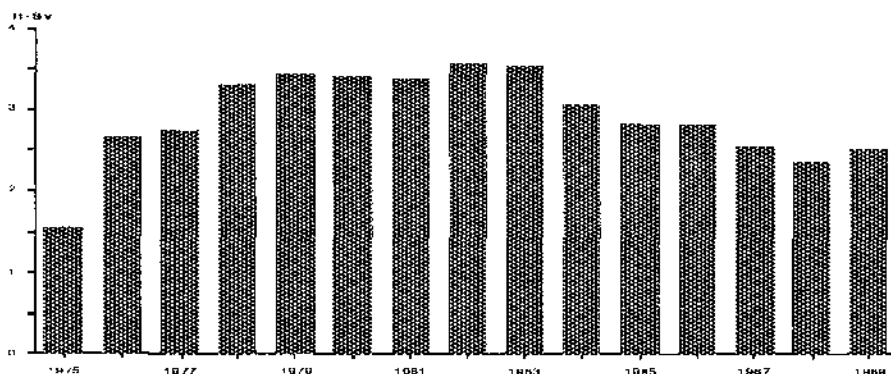

Figure 1 : Evolution de la dose collective annuelle moyenne par réacteur (1975-1989)

L'analyse selon le nombre d'années d'exploitation met en évidence une nette augmentation de la dose collective moyenne par réacteur au cours des huit premières années d'exploitation.

La tendance se poursuit ensuite mais des écarts importants apparaissent d'une année sur l'autre dans la mesure où cette moyenne correspond à un nombre de réacteurs de plus en plus réduit.

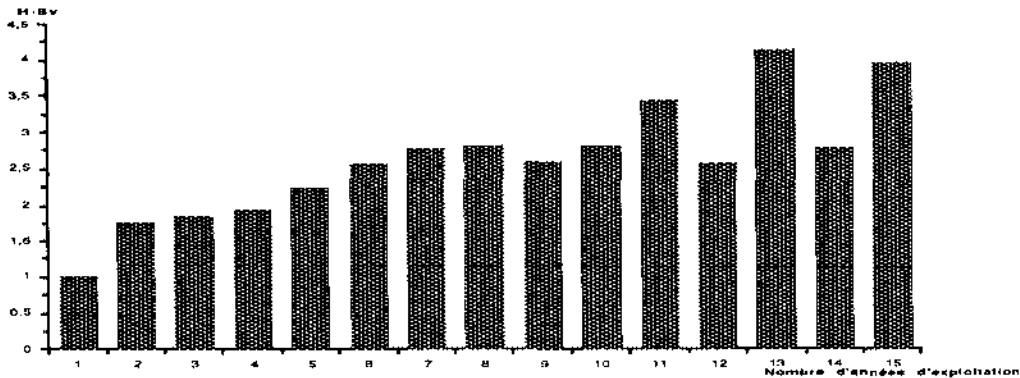

Figure 2 : Evolution de la dose collective moyenne par réacteur en fonction du nombre d'années d'exploitation.

L'examen des évolutions par pays montre des résultats assez différenciés dont l'explication ne peut reposer que sur une bonne connaissance des travaux effectués dans les réacteurs, en liaison avec des analyses de la structure par âge et par génération des différents parcs.

III - LA REPARTITION DE L'EXPOSITION ENTRE LES TRAVAILLEURS DES EXPLOITANTS ET CEUX DES ENTREPRISES EXTERIEURES

Le mode d'exploitation des REP induit qu'une part importante des travaux de maintenance est confiée à des entreprises extérieures. En moyenne, sur l'ensemble des pays, l'exposition des agents de ces dernières est passé de 67 % de l'exposition totale annuelle en 1980 à 74 % en 1988. Toutefois comme l'indique la Figure 3 la contribution des travailleurs des entreprises extérieures à l'exposition totale varie assez sensiblement selon les pays.

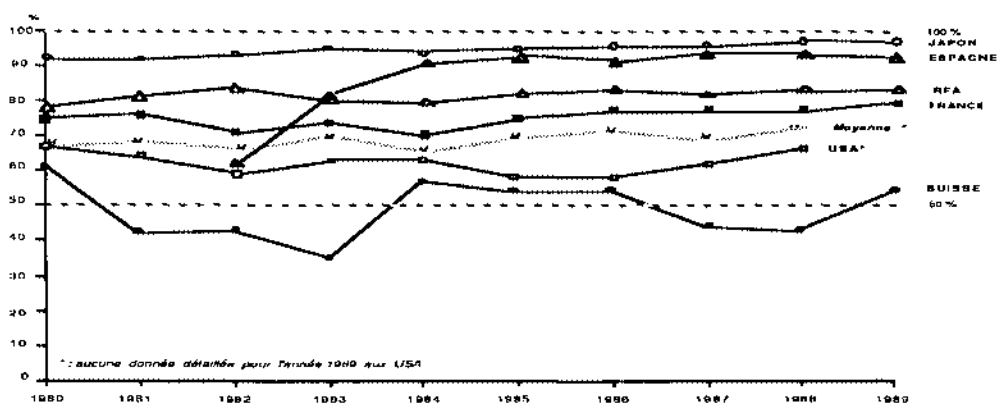

Figure 3 : Part de l'exposition des travailleurs des entreprises extérieures dans la dose collective annuelle selon les pays.

En ce qui concerne l'exposition individuelle moyenne annuelle, la situation est clairement appréhendable pour le personnel des centrales. L'évolution sur la période 1975-1989 montre une tendance à la baisse depuis 1980 où la valeur moyenne était de 2,6 mSv, alors qu'elle n'est plus que de 1,6 mSv en 1989. En revanche, pour le personnel des entreprises extérieures, la situation est beaucoup plus confuse. Les seules données disponibles, à quelques exceptions près, ne concernent que les expositions associées à chaque réacteur. Une fraction non négligeable de ce type de personnel intervient sur plusieurs réacteurs chaque année. Il est donc impossible en l'absence de systèmes centralisés, de reconstituer les doses annuelles individuelles moyennes.

IV - CONCLUSION

L'évolution générale de la dosimétrie professionnelle dans les REP est la résultante de deux tendances contradictoires. D'un côté, le vieillissement des installations conduit à un accroissement des travaux de maintenance qui pèsent de plus en plus lourd dans les bilans dosimétriques. A ces travaux viennent souvent s'ajouter ceux engagés pour améliorer la sûreté. De l'autre côté, les efforts entrepris pour mieux contrôler les sources, le développement d'outillages spécialisés et de la robotique, les progrès au niveau des protections et de l'organisation du travail en milieu irradiant permettent de maintenir, sinon de réduire, les niveaux d'exposition des travailleurs.

Globalement, au vu des résultats présentés ci-dessus, il semble que les effets positifs associés au retour d'expérience aient permis une évolution favorable de l'exposition. L'introduction de nouveaux réacteurs beaucoup plus performants sur le plan de la dosimétrie semble plus que compenser les effets négatifs du vieillissement.

Compte tenu de la diminution des mises en service de nouveaux réacteurs dans les années à venir il est difficile d'assurer que la tendance passée se poursuivra sans envisager d'accroître la maîtrise des sources et des interventions du personnel dans les réacteurs mis en service dans les années quatre-vingt.

Dans ce contexte, l'analyse approfondie des données du retour d'expérience et leur mise en commun, associée à la mise en oeuvre plus systématique de la démarche ALARA apparaissent comme indispensables pour s'assurer, d'une part que toutes les potentialités de réduction des expositions ont été exploitées et, d'autre part que les efforts de radioprotection consentis sont compatibles avec les conditions d'exploitation des installations.

REFERENCES

M. Benedittini, M. Tabare, "Expositions professionnelles dans les réacteurs à eau pressurisée : évolution et comparaison internationale entre 1975 et 1989", Rapport CEPN-R178, Nov. 1991.

P. Boussard, "Situation et conséquences des nouvelles recommandations de la CIPR pour les réacteurs français", Communication aux journées BNS/SFEN, Bruxelles, 30 & 31 mai 1991.

FRENCH NUCLEAR POWER PLANTS ACCUMULATED DOSE
INTERNATIONAL COMPARISONS

J. STAIMESSE (*), A. BRISSAUD (**), J.L. TROMBINI (***)

(*) EDF/UTO, BP 129, 93612 NOISY LE GRAND CEDEX - FRANCE

(**) EDF/SEPTEN, 12-14 avenue Dutriévoz, 69628 VILLEURBANNE CEDEX - FRANCE

(***) EDF/DSRE, 6 rue Ampère, 93203 SAINT DENIS CEDEX 1 - FRANCE

After ten years of operation, the accumulated dose of the PWR french nuclear power plants is generally positive. In comparison to countries having an important number of nuclear power plants, like JAPON or US, the french results are better.

More or less, the tendency to an increase of certains indicators, like the annual average dose by reactor, or the dose by product energy, obliged us to follow our efforts to continue our goods results.

BILAN DOSIMETRIQUE DU PARC REP FRANCAIS
Comparaisons Internationales

Après une dizaine d'année de fonctionnement, le bilan dosimétrique du parc REP français est globalement positif. Par rapport à des pays ayant un parc électronucléaire important, comme le JAPON ou les USA, les résultats français sont meilleurs. Néanmoins, la tendance à la hausse de certains indicateurs, comme la dose moyenne annuelle par réacteur ou la dose par énergie produite, nous impose de poursuivre nos efforts pour conserver de bons résultats.

INTRODUCTION

Entre la première divergence de FESSENHEIM 1 en 1977 et aujourd'hui, ce sont 34 tranches REP 900 MW et 17 tranches REP 1300 MW qui ont été couplées au réseau. L'âge moyen du parc est d'environ 8 ans.

DOSIMETRIE MOYENNE PAR REACTEUR (figure 1)

La dose moyenne annuelle du parc REP par réacteur oscille autour de 2,3 h.Sv, avec une tendance à la hausse depuis 1989.

Cette augmentation est causée en particulier par :

- le plus grand nombre des arrêts de tranche pour rechargement et l'allongement de leur durée,
- la réalisation des premières visites décennales de tranches 900 MW longues et plus coûteuses en dose qu'une simple visite pour rechargement.

Il est à noter un meilleur comportement des tranches du palier 1300 MW dont la moyenne annuelle est voisine de 1,5 h.Sv, ce qui est dû aux valeurs plus faibles de débit de dose dans les locaux et au voisinage des matériels (les moindres teneurs en cobalt des tubes de générateur de vapeur et l'application, dès le démarrage de ces tranches, de spécifications radiochimiques lors des mises en arrêt en froid ne sont pas étrangères à ces meilleurs résultats).

COMPARAISON INTERNATIONALE (figure 2)

Alors que la dose moyenne annuelle par réacteur oscille aux environs de 2,3 h.Sv avec une tendance à la hausse depuis 1989 en FRANCE, on constate une tendance inverse continue à la baisse pour les USA, le JAPON et l'ALLEMAGNE.

Il en est de même pour l'indicateur de dose collective divisée par l'énergie produite.

Ces pays appliquent depuis plusieurs années le principe ALARA dans le domaine de la radioprotection.

Il faut noter également qu'à l'étranger, de plus en plus de tranches réalisent aujourd'hui des campagnes longues de 18 à 20 mois contrairement au parc REP français, où pour des considérations économiques de combustible un cycle dure environ 1 an. Le calcul de la dose moyenne annuelle est fortement influencé par l'espacement des arrêts de tranche, la dose d'arrêt de tranche étant environ 3 fois la dose prise au cours d'une année de fonctionnement.

DOSE PAR ENERGIE PRODUITE (figure 3)

La dose par énergie produite oscille aux environs de 3 h.mSv/MW.an pour l'ensemble du parc REP.

Elle est voisine de 2 h.mSv/MW.an pour les centrales REP 1300 MW qui sont plus récentes et où les débits de dose tant ambiants que sur les matériels, sont plus faibles ; les doses reçues par le personnel sont donc plus réduites.

COMPARAISON INTERNATIONALE (figure 4)

Par rapport aux pays étrangers comparés précédemment (USA, JAPON, ALLEMAGNE), le parc français présente un bilan dose/énergie produite satisfaisant.

CONCLUSION

Le bilan dosimétrique du parc REP est satisfaisant. Cette situation est la combinaison de facteurs favorables :

- abaissement de la teneur en cobalt des tubes GV,
- application d'un conditionnement chimique rigoureux,
- application d'une procédure de mise en arrêt à froid performante,
- gestion rationnelle des assemblages combustibles pour maîtriser la contamination par produits de fission,

et défavorables :

- "maladies" génériques : jet de baffle, broches, tubes guides, tubes GV, piquages pressuriseurs, ...,
- augmentation de la durée des arrêts de tranche,
- augmentation des contrôles.

Pour conserver et peut-être améliorer ces résultats, il est nécessaire de persévérer et d'améliorer nos conditions d'interventions.

DOSE MOYENNE DU PARC REP PAR REACTEUR

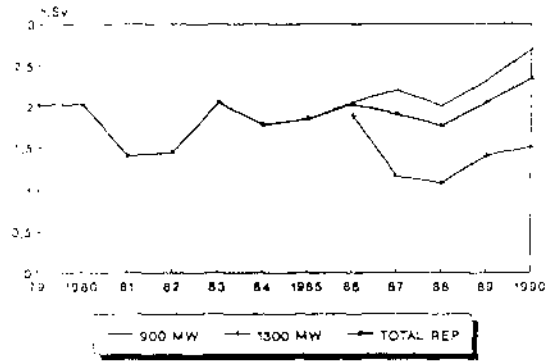

Figure 1

DOSE COLLECTIVE PAR ENERGIE PRODUITE

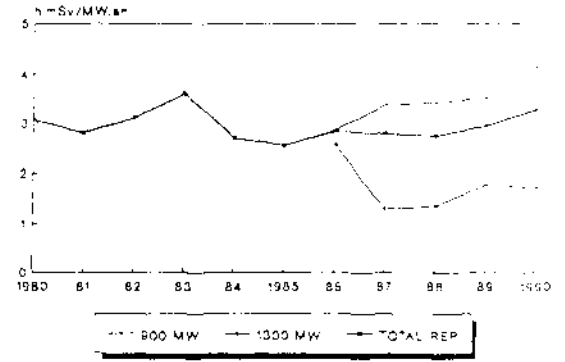

Figure 3

705

Comparaison internationale

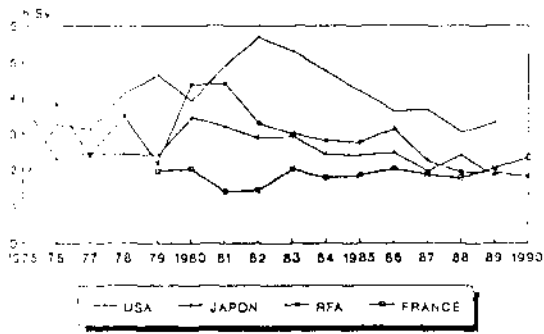

Figure 2

Comparaison internationale

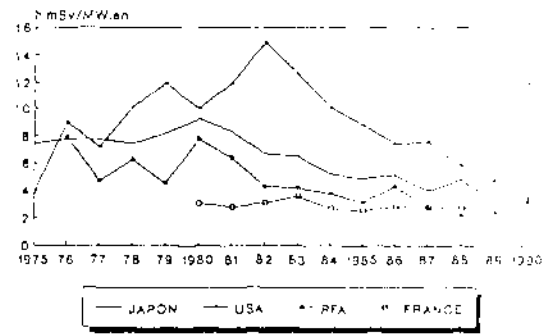

Figure 4

PROPERTIES OF AEROSOL FLOATING IN THE AIR IN A NUCLEAR
POWER PLANT WORKPLACE ENVIRONMENT

Hideaki KARASAWA, Makoto FUJIBASHI

TOSHIBA Corp, Nuclear Engineering Laboratory,
4-1, Ukishima-cho, Kawasaki-ku, Kawasaki, Kanagawa, 210, Japan

Makoto ITO

Tokyo Electric Power Co, Ltd.
1-3, Uchisaiwaicho 1-chome, Chiyoda-ku, Tokyo, 100, Japan

ABSTRACT

An investigation was carried out on properties of radioactive aerosol floating in the air at several workplaces in a nuclear power plant.

The principal results are as follows:

- (1) The aerosol particle size distributions consisted of two particle groups, whose aerodynamic diameters ranged from 4 to 7 microns and from 0.4 to 0.6 microns.
- (2) The radioactive aerosol particle size distribution were unimodal. The mean activity median aerodynamic diameter (AMAD) was 6 microns, with geometric standard deviation 1.9 microns.
- (3) The average density of the aerosol was about 2.2g/cm^3 .

INTRODUCTION

Knowledge of the particle size distribution of radioactive aerosol floating in the environmental air at workplaces in a facility handling radioactive materials is essential for estimating the internal radiation exposure dose of workers, caused by respiration and for monitoring the concentration of radioactive aerosol.

Task Group on Lung Dynamics of the ICRP has proposed a lung model for estimating the dose, following inhalation of radioactive aerosol.^{1,2} This model takes particle size into account and also defines three classes of retention, which, in part, reflect the chemical form of the aerosol. This model shows that the pattern of deposition can be related to the activity median aerodynamic diameter (AMAD) of the aerosol, for a log-normal distribution of diameters, which seems typical distribution of aerosol. Therefore the particle size distributions of radioactive aerosol are important and have been studied in detail in the present work.

Aerosol particles floating in the air at several workplaces were sampled during the maintenance period of a nuclear power plant. Analysis were carried out for the samples and particle size distributions of total aerosol and radioactive aerosol were determined.

MEASUREMENTS AND DATA ANALYSIS

Samples of aerosol floating in the environmental air at several workplaces in a nuclear power plant were collected with a cascade impactor (Andersen sampler model AN200). The Andersen sampler consists of 8 stages and a backup filter, and flow rate was regulated at 28.3 l/min. The height of sampling position was about 1.2 meter above the working floor, corresponding to the worker's respiratory zone. The sampling time was 60 to 90 hours at a workplace. After sampling, the weight of the aerosol particles taken at each sampler plate (stage) were measured with a micro balance (minimum detectable weight is 0.01mg) and gamma radioactivity of the each plate (stage) were measured with a Ge-detector and a multichannel pulse height analyser.

Data analysis for particle size distribution of aerosol were made with the method proposed by Fujimura and Hashimoto⁽³⁾. In this method, at first, a cumulative distribution curve $F(D)$ for aerosol particle diameter D is drawn by plotting the percentages of cumulative weight (or radioactivity) on a semi-logarithmic graphpaper. Then, the $F(D)$ curve is differentiated to obtain a frequency distribution curve $f(D)$, by plotting the gradient $dF(D)/d(\log D)$. It is suitable to obtain an intuitive image of the size distribution for aerosol particles.

The "Floating Method" was used to determine particle density. In this method, aerosol accumulations were soaked into a liquid and the liquid density was changed by mixing two other liquids whose densities were different from each other. If the aerosol density was equal to the liquid density, the aerosol particles float in the liquid. So, by measuring the liquid density, the aerosol density can be obtained.

RESULTS

The aerosol size distribution (mass frequency distribution) was found to be bimodal, as shown in Fig.1, consisted of two particle size groups, whose aerodynamic diameters were 4 to 7 microns and 0.4 to 0.6 microns. The particle size distribution for each aerosol group closely resembled to logarithmic normal distribution. Their average mass median aerodynamic diameter was 6 microns and 0.5 microns, with geometric standard deviations of 1.9 and 2.1 microns, respectively.

On the other hand, the particle size distribution for radioactive aerosol were found to be unimodal, as shown in Fig.2. The mean activity median aerodynamic diameter (AMAD) was 6 microns with geometric standard deviation of 1.9 microns. As shown in Fig.3, the concentration of radioactive aerosol particles in the air strongly depended on the concentration of larger particle group, whose aerodynamic diameters were 4 to 7 microns.

The radioactive nuclides, included in the aerosol,

were Cr-51, Mn-54, Fe-59, Co-58, Co-60, Zn-65 and Ag-110m. These radioactive nuclides were activation products of structural materials by neutrons. The main radioactive nuclides were Mn-54 and Co-60.

The densities of aerosol, measured by the "Floating Method", is shown in Table 1. Measured densities for aerosol were ranged from 1.8 to 2.6 g/cm³ in place by place, and average aerosol density was about 2.2 g/cm³.

Other observed properties of the aerosol were chemical elements. The main chemical element included in the aerosol was iron.

CONCLUSION

An investigation was carried out on properties of radioactive aerosol floating in the environmental air at workplaces of a nuclear power plant.

The results are as follows:

- (1) The aerosol particle size distributions consisted of two particle groups, whose aerodynamic diameters ranged from 4 to 7 microns and from 0.4 to 0.6 microns.
- (2) The particle size distributions for each aerosol group closely resembled to logarithmic normal distribution. Their mean mass median aerodynamic diameter (MMAD) was 6.0 and 0.5 microns with geometric standard deviations of 1.9 and 2.1 microns, respectively.
- (3) The particle size distribution of radioactive aerosol were unimodal. The mean activity median aerodynamic diameter (AMAD) was 6 microns, with geometric standard deviation of 1.9 microns. The radioactive aerosol concentration in the air strongly depended on the concentration of the larger particle group, whose aerodynamic diameters ranged from 4 to 7 microns.
- (4) Other observed properties were:
 - (a) The average density of the aerosol was about 2.2g/cm³.
 - (b) The main radioactive nuclides, included in the aerosol were Mn-54 and Co-60.
 - (c) The main chemical element, included in the aerosol was iron.

REFERENCES

1. ICRP Task Group on Lung Dynamics(1966). Deposition and retention models for internal dosimetry of the human respiratory tract. Health Phys., 19, 173-207
2. ICRP Publication 30, Limits for Intakes of Radionuclides by Workers. Pergamon Press, Oxford, 1979.
3. Mitsuru FUJIMURA, Yoshikazu HASHIMOTO; Analysis of size distribution data of particulate matters by Andersen sampler (in Japanese), Analytical Chemistry, 24, 36-41, 1975

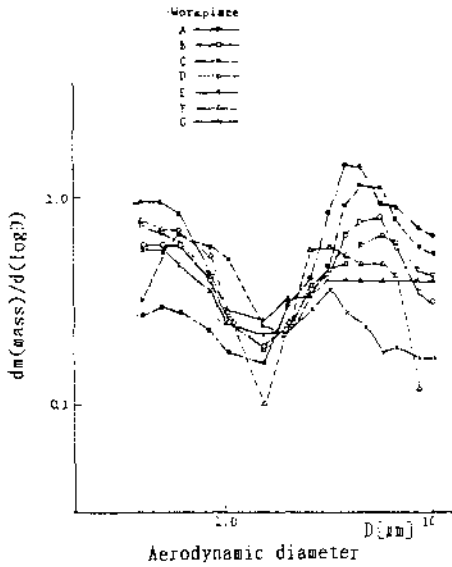

Fig.1 Particle size distribution of aerosol in workplace [Mass]

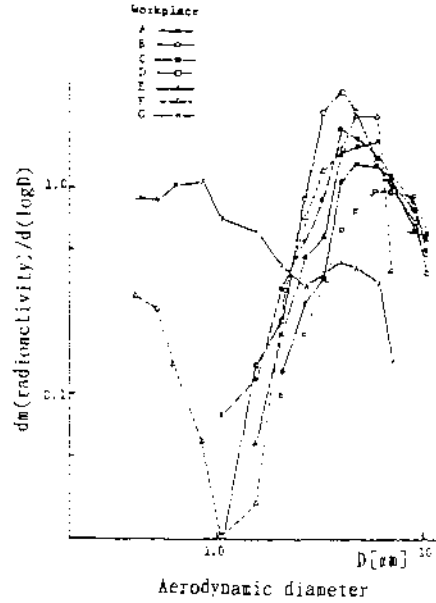

Fig.2 Particle size distribution of aerosol in workplace [radioactivity]

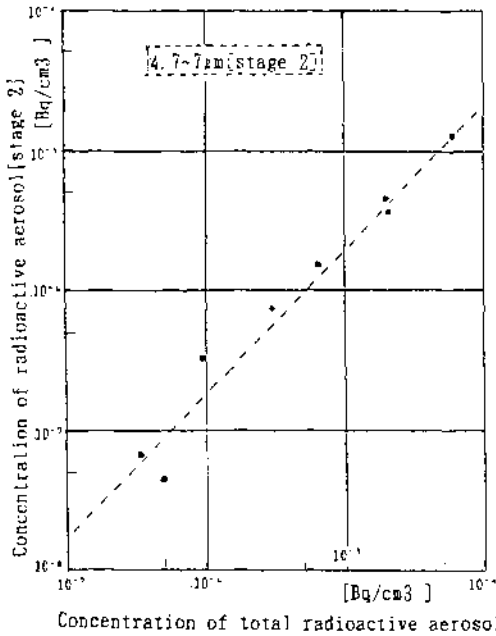

Fig.3 Relationship between concentration of total radioactive aerosol and concentration of radioactive aerosol at [stage2]

Table 1 Particle density of aerosol

Workplace	Particle Density (g/cm ³)
A	2.6
F	1.8
C	2.0
D	2.0
E	2.2
F	2.5
G	2.6
Average of Particle Density	2.2

RISK MODELS FOR ESTIMATING LIFETIME CANCER PROBABILITY: ALTERNATIVE TO RELATIVE RISK MODEL BY UNSCEAR/ICRP

M. KAI and T. KUSAMA

Department of Radiological Health, Faculty of Medicine,
The University of Tokyo, Tokyo, JAPAN

ABSTRACT

Based on the carcinogenesis model as proposed by Moolgavkar et al., time-dependent relative risk models were derived for projecting time variation in excess relative risk. If it is assumed that each process is described by time-independent linear dose-response relationship, the time variation in excess relative risk is influenced by the parameter related with the promotion process. Its parameter was discussed by analyzing spontaneous cancer incidence data. The model predicts larger variation in relative risk with time for younger ages at exposure.

INTRODUCTION

The ICRP adopted relative risk models for radiation-induced lifetime cancer probability in the 1990 recommendation(1). The application of the relative risk projection model mainly causes higher lifetime cancer probability than the ICRP 1977 recommendation(2). The main background why the ICRP adopted the relative risk model is based on the epidemiological data of A-bomb survivors in Japan. The atomic bomb data indicate that the variation of relative risk with time is constant for a given age-at-exposure, but the transfer of the constant relative risk to population other than the Japanese cannot be verified by the statistical models based only on the data fitting. However, there is no biological basis for projecting excess hazard rate of radiation. The carcinogenesis model as proposed by Moolgavkar et al.(3,4) can give a good fitting and interpretation for the age-dependent spontaneous cancer incidence rate of a specific population data. In this paper a risk projection model will be derived from the carcinogenesis model as biological basis. Moreover, the time variation in relative risk for age at exposure will be discussed.

CARCINOGENESIS MODELS

Moolgavkar et al.(2,3) proposed the two-stage carcinogenesis model, which will be referred to as MVK models below. The two-stage carcinogenesis model assumes that stem cells change to initiated cells by first mutation and furthermore tumor cells are induced by second mutation. In addition, the MVK model is a stochastic model which deals with a homogeneous filtered Poisson process of initiated cells. In the case of epidemiological data, the approximation of the hazard rate as an expected value is as follows:

$$r(t) = u_2(t) \int_0^1 \left\{ u_1(s) X(s) \exp\left(\int_s^1 [a(u)-b(u)] du \right) \right\} ds. \quad (\text{Eq.1})$$

DERIVATION OF MATHEMATICAL MODELS

It is assumed that each process is described by linear dose-response relationship which is time-independent. Furthermore, it can be assumed that a single exposure to radiation acts as an initiator. On these assumptions, if the stem cell population is constant, the hazard rate of spontaneous cancer ($R_s(t)$) and excess hazard rate ($R_r(t)$) due to a single exposure can be derived as:

$$R_s(t) = N_0 ac/g \{ \exp(gt) - 1 \} \quad (\text{Eq.2})$$

$$R_r(t) = N_0 bcx \exp[g(t-t_0)], \quad (\text{Eq.3})$$

using the expressions as $u_1(t)=a+bx$, $u_2(t)=c$ and $a(t)-b(t)=g$.

In addition, N_0 , x , t and t_0 represent the number of normal cells, dose, attained age and age-at-exposure, respectively. The parameter g is the net rate of proliferating initiated cells and plays an important role in projecting the variation in relative risk. The above expressions are the most simple form with minimum unknown parameters.

If the growth of the normal stem cell population is modeled by an exponential function until t_1 , the hazard rate of spontaneous cancer is then described by the summation of hazard rates that originate from the numbers of cells which are initiated until t_x and are initiated after t_x . The expression can be given by:

$$R_s(t) = \begin{cases} \left\{ \frac{ack}{(L-g)} \right\} \{ \exp[L-g)t_x + gt] - \exp(gt) \} \\ \quad + (acN_0/g) \{ \exp[g(t-t_x)] - 1 \} & \text{if } t > t_x \quad (\text{Eq. 4}) \\ \left\{ \frac{ack}{(L-g)} \right\} \{ \exp(Lt) - \exp(gt) \} & \text{if } t < t_x \quad (\text{Eq. 5}) \end{cases}$$

where it is assumed that $X(t)=k\exp(Lt)$ ($t < t_x$). The excess hazard rate due to a single exposure can be obtained as:

$$R_r(t) = \begin{cases} (kbcx)\exp[g(t-t_0)+Lt_0] & \text{if } t_0 < t_x \quad (\text{Eq. 6}) \\ (N_0bcx)\exp[g(t-t_0)] & \text{if } t_0 > t_x \quad (\text{Eq. 7}) \end{cases}$$

The expression of hazard rates involving time-dependent processes can be derived by dividing the age into two or more age groups in which the parameters are assumed to be time-independent. In the case of two age groups, the expression for the hazard rate of spontaneous cancer shown in Eq.2 must be rewritten into:

$$R_s(t) = \begin{cases} (N_0a_1c/g_1) \{ \exp[g_2(t-t_1)] \} \{ \exp(g_1t_1) - 1 \} \\ \quad + (N_0a_2c/g_2) \{ \exp[g_2(t-t_1)] - 1 \} & \text{if } t > t_1 \quad (\text{Eq. 8}) \end{cases}$$

where the parameters of g_1 and g_2 are the net rates of proliferating initiated cells in each age group, and those of a_1 and a_2 are mutation rates per cell per year of one normal cell into one initiated cell. If $t_0 < t_1$, the excess hazard rate due to a single exposure can be obtained as:

$$R_r(t) = \begin{cases} (N_0bcx)\exp[g_1(t-t_0)] & \text{if } t < t_1 \quad (\text{Eq. 9}) \\ (N_0bcx)\exp[g_1(t_1-t_0)+g_2(t-t_1)] & \text{if } t > t_1 \quad (\text{Eq. 10}) \end{cases}$$

MODEL FITTING TO SPONTANEOUS CANCER DATA

The cancer incidence data from 20 to 80 years of age in Japan in 1985(5) were used for the parameters by model fitting. By using Eq.2 and Eq.8, in which $t_1=60$, the results of data fitting to the incidence rates of lung cancer and stomach cancer of males were obtained as shown in Fig.1 and Fig.2, respectively. These organs have higher cancer probabilities in ICRP Pub.60. The MVK model agrees with the spontaneous cancer data.

PREDICTED TIME VARIATION IN EXCESS RELATIVE RISK

The reduction in excess relative risk can be predicted by the g parameter which is obtained by data fitting to spontaneous cancer incidence rates. Figure 3 illustrates the excess relative risk in stomach for a single exposure at adult age or young age. The excess relative risk for the young age decreases more rapidly with time than that for the adult age. This is

influenced by the age-dependence of the growth of radiation-induced initiated cells and spontaneously induced initiated cells.

CONCLUSION

It was suggested that the MVK model is a useful tool as a carcinogenesis model for projecting the time variation in excess relative risk. The reduction rate in excess relative risk can be obtained by the data fitting to spontaneous cancer incidence data. For adult exposure, the excess relative risks are approximately constant for some cancers such as lung, colon and stomach. However, for breast cancer, the excess relative risk decreases with attained age. In applying the above risk model to epidemiological data for estimating lifetime cancer probability, the parameters related with the time variation in relative risk can be estimated by analyzing the spontaneous cancer incidence data.

REFERENCES

1. ICRP Publication 60, 1990 recommendations of the International Commission on Radiological Protection. *Annals of the ICRP*, 21(1-3) (1991).
2. ICRP Publication 26, Recommendations of the International Commission on Radiological Protection. *Annals of the ICRP*, 1(3), (1977).
3. Moolgavkar, S.H. and Venzon, D.J. Two-Event Models for Carcinogenesis: Incidence Curves for Childhood and Adult Tumors. *Math. Biosciences* 47, 55-77 (1979).
4. Moolgavkar, S.H. and Knudson, A.G. Mutation and Cancer: A Model for Human Carcinogenesis. *JNCI* 66, 1037-1052 (1981).
5. Research Group for Population-based Cancer Registration in Japan, Cancer Incidence and Incidence Rates in Japan in 1985 - Estimates Based on Data from Seven Population-based Cancer Registries - . *Jpn. J. Clin. Oncol.* 20, 212-218 (1990).

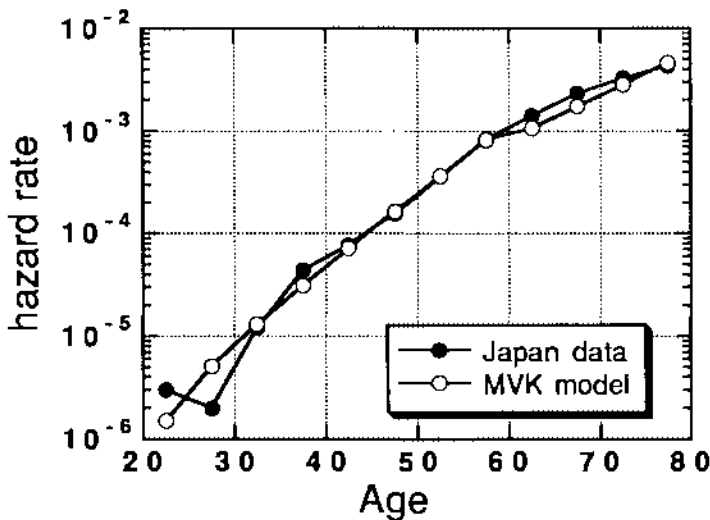

Fig. 1 Lung cancer incidence in Japan and the data fitting by MVK model.

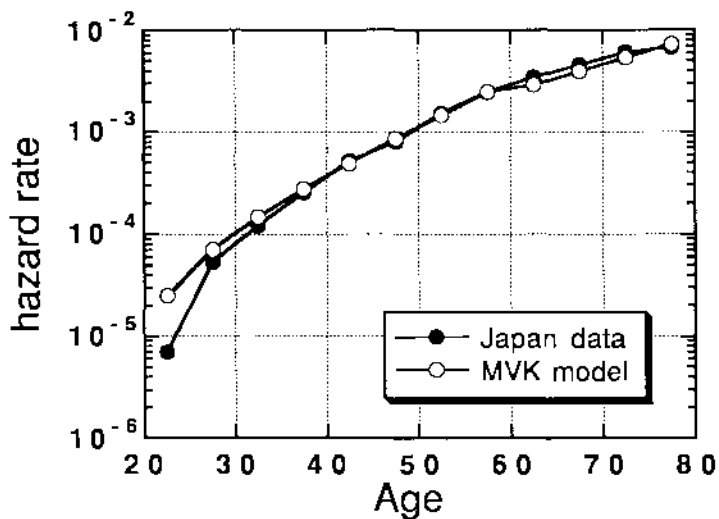

Fig. 2 Stomach cancer incidence in Japan and the data fitting by MVK model.

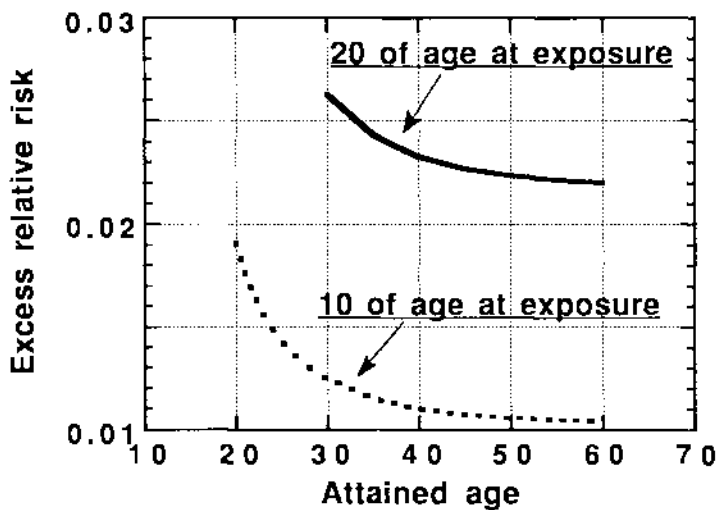

Fig. 3 Predicted time variation in excess relative risk. The mutation rate per cell per year of one normal cell into one initiated cell is assumed to be independent of age-at-exposure.

EPIDEMIOLOGY OF PLUTONIUM WORKERS

G. L. Voelz, L. D. Wiggs, and W. A. Galke

Los Alamos National Laboratory
Los Alamos, New Mexico, U.S.A.

ABSTRACT

Workers at several U.S. plutonium (Pu) processing or research facilities are subjects of the National Plutonium Workers Study. Mortality from all causes and all cancers has not been elevated in these cohorts compared with rates in the general U.S. population. Mortality from all causes and blood cell neoplasms was statistically elevated in Pu-exposed workers at Rocky Flats compared with those not exposed to Pu. Linear dose-response trends were not observed. Bone sarcoma in a Los Alamos Pu exposed worker is noteworthy because bone tumors are an important cancer found in Pu exposed dogs.

INTRODUCTION

The National Plutonium Workers Study uses a historical cohort mortality design to study the long term health experience of four worker populations: Los Alamos National Laboratory and Zia Co., Los Alamos, NM; Rocky Flats plant near Denver, CO; and Mound facility near Dayton, OH. About 54,300 workers have been employed at these facilities from the onset of operations until 1979. The cohorts include over 80% of all persons with occupational exposures to Pu in the U.S. Seventy seven percent of the workers are white males. Vital status of white males in these cohorts is known with about 95% completeness thru the end of 1983.

Monitoring for internal Pu deposition, primarily by measurement of Pu in one or more urine samples, has been done on 13,750 (25%) of the 54,300 workers. Selection is based on the potential for exposure in work assignments. About 1800 workers are estimated to have Pu depositions of more than 74 Bq. The majority of these depositions are ^{239}Pu , but some ^{238}Pu exposures are also present. Estimates of depositions below the arbitrary value of 74 Bq Pu are considered to be too uncertain to be included in the exposed category. Regarding higher depositions, only fifty workers are estimated to have depositions above 1480 Bq Pu, which is the lifetime maximum permissible body burden guideline used during the years under study.

Eighteen percent of the white males in these cohorts have cumulative external doses in excess of 10 mSv. External radiation exposure is a potential confounding factor in these studies. Plutonium work involves exposure to external gamma and neutron doses. The contribution from neutron exposures is either not known or has large uncertainties in the personnel dosimetry data from the 1940s into the 1970s.

MORTALITY OF PLUTONIUM WORKERS

Using mortality rates of the U.S. general population for comparison, the standardized mortality ratios (SMR) for deaths from all causes in the cohorts (unexposed and exposed workers) studied to date are all significantly less than 100.¹⁻⁵ A ratio below 100 means the mortality rate of the study cohort is less than that of the comparison group. The low SMRs are attributed to a large healthy worker effect, which is frequently observed in studies of employed populations when occupational health impacts are absent or small. The SMRs for deaths from all cancers are also low in these cohorts.

Rate ratios comparing mortality rates of Pu-exposed workers with those of unexposed workers were calculated for the Rocky Flats workers.¹ If the mortality rates of exposed and unexposed workers are equal, the rate ratio is 1.0. If the mortality rate of the exposed exceeds the unexposed, the rate ratio is above 1.0. This type of internal comparison has an advantage over external comparison with state or national rates, because employment procedures for the exposed and unexposed persons are the same. The use of internal comparisons essentially eliminates the healthy worker effect. Using 5-year and 10-year induction times, the stratified rate ratios for all causes of death for Rocky Flats workers exposed above 74 Bq Pu are significantly elevated at 1.33 (90% confidence intervals (CI) = 1.05, 1.68) and 1.39 (CI = 1.04, 1.87) respectively. Persons exposed to external radiation (>10 mSv) did not exhibit elevated rate ratios. Interpretation of this observation will be strengthened if the finding is confirmed in other studies. The stratified rate ratios for all cancer deaths were 1.24 (CI = 0.75, 2.07) and 1.61 (CI = 0.88, 2.93) for 5- and 10-year induction times respectively.

CANCERS OF SPECIAL INTEREST

Experimental studies in rodents and dogs have shown plutonium concentrations to be highest in lung and tracheobronchial lymph nodes after inhalation of insoluble Pu particulates. Soluble Pu compounds are distributed primarily to bone and liver. It is thus not surprising that animal experiments showed excess cancers primarily in lung (after inhalation exposures only), bone, and liver. Bone tumors in dogs were most frequently osteogenic sarcomas arising in trabecular bone. Leukemias and myeloproliferative disorders were not prominent findings in the dog studies.

The following sections describe selected findings to date in studies of workers. It is anticipated that the induction time for Pu-induced cancers is likely to be very long, perhaps in excess of 30 years. These epidemiologic research studies should continue and will record such events as they unfold.

Bone Cancer. In a clinical study of 26 workers exposed at Los Alamos in 1944-5, one individual died of an osteogenic sarcoma in 1990.⁵ The latent period from exposure to the time

of initial clinical symptoms was 43 years. It appears that this is the first case in which a bone tumor has been observed in a person exposed to Pu. The estimates of ^{239}Pu deposition in this case, using urine excretion measurements, range from an initial maximum of 740 Bq to 560 Bq at the end of his life. These depositions are somewhat lower than current radiation protection guidelines would allow. The cumulative dose to bone surface is estimated to be 0.44 Gy. This estimated dose is similar to the lowest skeletal doses in Pu exposed dogs that have developed bone tumors.

The incidence of bone cancer in humans is ordinarily low. In a group of 26 adult males over a 40+ year period, the likelihood is only about 1% that a bone cancer would occur.

Blood Cell Neoplasms. This term is used here to describe a group of neoplasms originating from a variety of cell types in lymphatic and hematopoietic tissues, including all leukemias, lymphomas, and multiple myeloma. This group (ICDA 8th Revision, Codes 200-209) is convenient to use for epidemiologic analyses when the number of observed cases is too small to evaluate specific diseases. It has frequently been used in studies of radiation health effects to evaluate potential effects on lymphoid and hematopoietic tissues. Several of these diseases have had an increased frequency associated with doses of external radiation.

The Rocky Flats study¹ indicated a 5 to 10 fold increased rate of blood cell neoplasms in Pu exposed workers compared to unexposed workers using 2-, 5-, and 10-year induction times. The rate for the 5-year induction time was 9.86 (90% CI = 1.26, 94.03). A linear dose-response trend was not present. It is interesting that the rate ratio for blood cell neoplasms in workers exposed to external radiation was not similarly elevated. This interesting group of diseases bears close watching as Pu epidemiology studies unfold.

Lung Cancer. Lung cancer mortality for the cohorts studied thus far in Pu handling facilities is not increased compared that in the U.S. general population. For example, the SMR for lung cancer of 64 (90% CI = 46, 87) in the Rocky Flats study¹ is significantly low. The same study indicates ratios of lung cancer rates for Pu exposed and unexposed workers are not significantly different using induction times of 2-, 5-, and 10-years. Analysis of the 10-year induction time gives a rate ratio of 1.4 (90% CI = 0.33, 4.65) based on the three lung cancer deaths in the exposed group.

An earlier study of 224 white males with the highest Pu exposures at Los Alamos observed an SMR of 20 (95% CI = 0, 110) for lung cancer.⁴ Only one death from lung cancer occurred over a 33-year follow-up period. In the study of 26 Manhattan Project Pu workers⁵, three lung cancers have been observed over a 44-year period, which is a higher incidence than expected but is still within the limits of expectation. All three men had a long history of cigarette smoking, which is an important confounding risk for lung cancer.

Liver Cancer. Mortality rates for cancers of the liver and gallbladder have not been elevated in the cohort studies to date.

Other Cancers. A two to three fold increase of brain tumors--benign and malignant combined--in Rocky Flats workers has been reported.¹ A case-control study of brain tumors showed no association between these tumors and radiation doses--either internal Pu depositions or external radiation.⁶ The reason for the excess brain tumors in this cohort is unknown, but it is clearly not from Pu deposition.

In the Pu-exposed worker cohort at Rocky Flats, six cancers of all digestive organs combined gives a rate ratio of 1.68 (90% CI = 0.58, 4.71) relative to the unexposed monitored workers using an induction time of 5 years. The ratios for 2- and 10-year induction times are 1.31 and 1.46. Wide confidence intervals suggest these results may well be due to chance, but elevated central values were not observed in the same study for workers exposed to external radiation .

REFERENCES

1. Wilkinson GS, Tietjen GL, Wiggs LD, et al.: Mortality among plutonium and other radiation workers at a plutonium weapons facility. *Am J Epidemiol* 105:231-250, 1987.
2. Wiggs LD, Cox-DeVore CA, Wilkinson GS, Reyes M: Mortality among workers exposed to external ionizing radiation at a nuclear facility in Ohio. *J Occup Med* 33:632-637, 1991.
3. Wiggs LD: Mortality among females employed by the Los Alamos National Laboratory. Thesis Dissertation, University of Oklahoma, Oklahoma City, OK, 1987.
4. Voelz GL, Wilkinson GS, Healy JW, et al.: Mortality study of Los Alamos workers with higher exposures to plutonium. Proceedings of the 16th Midyear Topical Meeting of the Health Physics Society, Albuquerque, NM January 10-13, 1983. CONF-83010. Technical Information Service, Washington, D.C. 1983, pp 318-327.
5. Voelz GL, Lawrence JNP: A 42-year medical follow-up of Manhattan Project plutonium workers. *Health Phy.* 61:181-190, 1991.
6. Reyes M, Wilkinson GS, Tietjen G, et al.: Brain tumors at a nuclear facility. *J Occup Med* 26:721-724, 1984.

ACKNOWLEDGEMENT

The National Plutonium Workers Study is funded by the U.S. Department of Energy.

INFLUENCE OF TIME AND DOSE RATE ON CANCER RISK
FROM INTERNALLY DEPOSITED RADIONUCLIDES

Otto G. Raabe

Department of Veterinary Pharmacology & Toxicology,
Department of Civil Engineering, and
Institute of Toxicology and Environmental Health
University of California, Davis, California 95616 USA

ABSTRACT

The effect of time and dose rate on cancer risk from protracted irradiation by internally deposited radionuclides forms a three-dimensional mathematical dose-rate/time/response relationship. Data were reviewed from lifetime studies with beagles exposed by injection, ingestion, or inhalation to either beta emitters or alpha emitters. The cumulative absorbed dose required to yield a specified level of cancer risk was found to be less at lower dose rates than at higher dose rates, but the time required for tumors to manifest tends to be much longer at lower dose rates and can exceed the natural life span, yielding a virtual threshold for fatal radiation-induced cancer. The $RBE(\alpha/\beta)$ was found to vary from about 1 at high dose rates to above 50 at low dose rates. These results can be scaled by life-span normalization to predict similar relationships in people.

INTRODUCTION

This report focuses on risks associated with radiation-induced cancer from internally deposited radionuclides with respect to the separate and independent risks of death associated with natural aging. Precise data obtained in lifetime studies utilizing beagles provide the basis for understanding the relationship of these risks.

The effect of time and dose rate on cancer risk from protracted irradiation by internally deposited radionuclides forms a three-dimensional mathematical dose-rate/time/response surface in which the coordinates for protracted exposure to the ionizing radiation are time-weighted average dose rate, elapsed time after intake, and risk given as the independent probability of death with radiation-induced cancer (1-2). Raabe et al. (3) used life-span normalization to scale response relationships from laboratory animal species to human risks.

METHODS

Selected data were reviewed from published reports of lifetime studies of internally deposited radionuclides in young adult beagles at four laboratories: University of California, Davis (4), Lovelace Inhalation Toxicology Research Institute, ITRI (5), University of Utah (5), and Battelle Pacific Northwest Laboratory, PNL (6). Data were reviewed for skeletal burdens of Sr-90 via ingestion at Davis, via injection at Utah, and via inhalation at ITRI, for lung burdens of inhaled Ce-144, Y-91, and Sr-90 in fused aluminosilicate particles (FAP) at ITRI and of inhaled Pu-239 dioxide at PNL, skeletal burdens of inhaled

Pu-238 at ITRI and of injected Ra-226 at Davis and Utah, and skeletal burdens of injected Ra-228, Pu-239, and Am-241 at Utah. Throughout this report, doses refer to average absorbed doses from parent and decay products in their appropriate proportions, where all X-ray and gamma emissions are ignored, and beta emissions are ignored when in combination with alpha emitters.

Because of an observed pattern of linearity between the logarithm of time to radiation induced cancer deaths and logarithm of lifetime average dose rate, standard log-linear survival models and maximum likelihood regression methods were used to describe the response functions (7). In terms of the natural logarithms, the log-linear regression line is thus given by:

$$\ln t_m = \ln K_m - s \ln \bar{d} \quad (1)$$

where \bar{d} is the time-weighted average dose rate, t_m is the median value of survival time, s is the negative slope of the regression line for the specified effect, and K_m is the coefficient describing the median risk. This regression line is equivalent to the power function:

$$t_m = K_m \bar{d}^{-s} \quad (2)$$

which describes the median survival time after intake.

RESULTS AND CONCLUSIONS

The results of these analyses are summarized in Fig. 1. The alpha emitting radionuclides all yielded cancer risk distributions with negative slopes of 1/3 and the beta emitting radionuclides all yielded cancer risk distributions with negative slopes of 2/3, showing that two beta particles are needed to cause the same cellular transformations produced by one alpha particle. Also, the underlying slope of 1/3 indicates that the distance between these events controls the response as a function of survival time as discussed by Raabe (2).

Because of the negative slopes of these distributions, the cumulative absorbed dose required to yield a specified level of cancer risk is less at lower dose rates than at higher dose rates, but the time required for tumors to manifest is much longer at lower dose rates and can exceed the natural life span, yielding a virtual threshold for fatal radiation-induced cancer.

This threshold occurs at about 0.08 Gy for Pu-238 and Pu-239 in bone, 0.2 Gy for Am-241 in bone, 0.5 Gy for Ra-228 in bone, 0.9 Gy for Pu-239 in lung, 1.4 Gy Ra-226 in bone, 28 Gy for Sr-90 in bone, 70 Gy for Y-91 in lung, 110 Gy for Ce-144 in lung, and 130 Gy for Sr-90 in lung.

Because the slopes of the response curves for alpha emitters differ from those for the low LET beta emitters, the

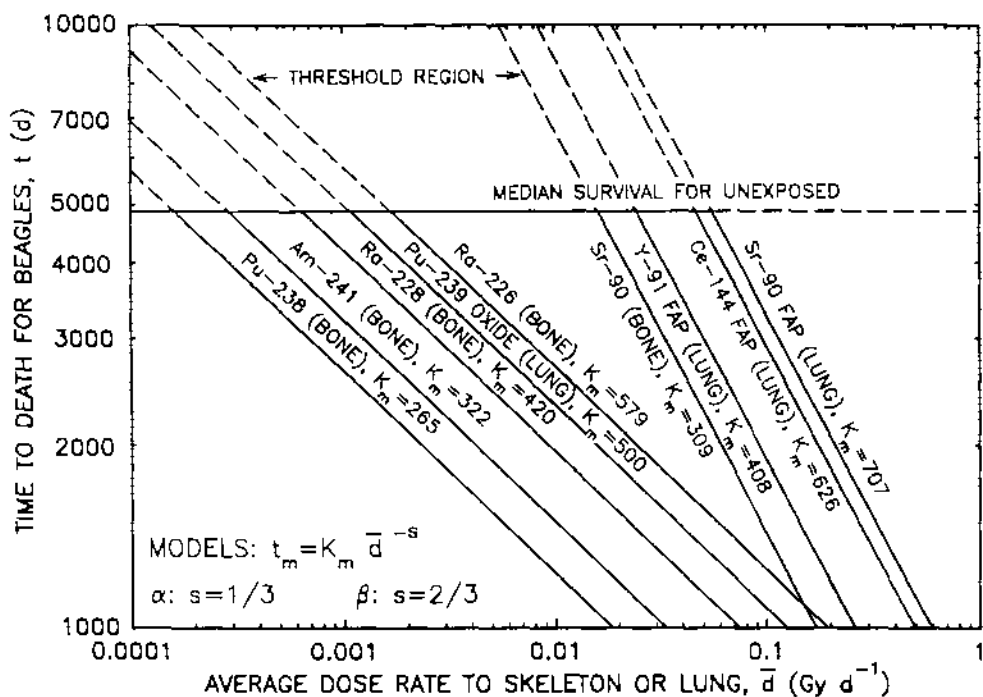

Figure 1: Median bone and lung cancer risks for beagles.

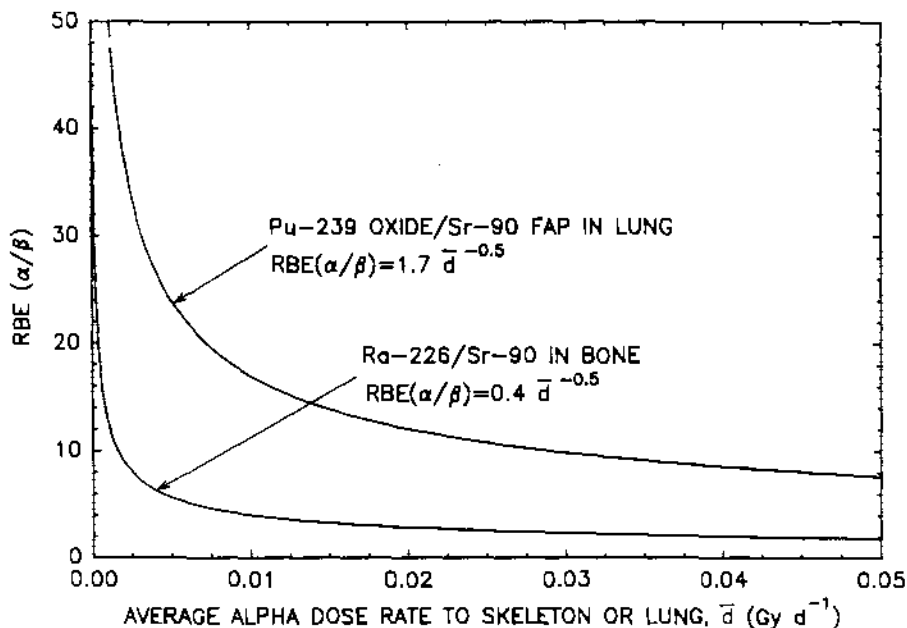

Figure 2: Apparent relative biological effectiveness, $RBE(\alpha/\beta)$, for beagle deaths with radiation-induced cancer.

observed relative biological effectiveness, $RBE(\alpha/\beta)$, varies as a function of dose rate, and rises as dose rate decreases. The $RBE(\alpha/\beta)$ contrasting Pu-239 dioxide with Sr-90 FAP at the median risk for fatal radiation-induced lung cancer in beagles and for Ra-226 versus Sr-90 bone cancer in beagles are shown in Fig. 2.

At high dose rates this radiation-induced cancer $RBE(\alpha/\beta)$ is small and rises to large values at low dose rates. As dose rate goes down the fatal radiation-induced cancer $RBE(\alpha/\beta)$ rises without limit; actually the beta effectiveness for producing radiation-induced cancer approaches zero. For example, for Pu-239 dioxide in lung at 0.1 Gy/day the $RBE(\alpha/\beta)=5$, while at 1 mGy/day $RBE(\alpha/\beta)=50$. The bone cancer $RBE(\alpha/\beta)=30$ at 1 mGy/day for Ra-226/Sr-90 in bone. Since Pu-238 and Pu-239 are about 10 times more effective than Ra-226 in producing bone cancer, the apparent $RBE(\alpha/\beta)=300$ for plutonium in bone at 1 mGy/day.

REFERENCES

1. Raabe, O.G., Parks, N.J., and Book, S.A., 1981, Dose-response relationships for bone tumors in beagles exposed to Ra-226 and Sr-90, Health Physics 40: 863-880.
2. Raabe, O.G., 1984, Comparison of the carcinogenicity of radium and bone-seeking actinides, Health Physics 46: 1241-1258.
3. Raabe, O.G., Rosenblatt, L.S., and Schlenker, R.A., 1990 Interspecies scaling of risk for radiation-induced bone cancer, International Journal of Radiation Biology 57, 1047-1061.
4. Raabe, O.G. and Abell, D.L., 1990. Laboratory for Energy-related Health Research Final Annual Report, UCD472-135, University of California, Davis, CA.
5. Boecker, B.B., Muggenburg, B.A., Miller, S.C., and Coors, T.A. (Eds.), 1990, Annual Report on Long-term Dose-response Studies of Inhaled or Injected Radionuclides 1988-89, LMF-128, Inhalation Toxicology Research Institute, NM
6. Park, J.F., 1991, Pacific Northwest Laboratory Annual Report for 1990 to the DOE Office of Energy Research: Part 1: Biomedical Sciences, Pacific Northwest Laboratory, WA.
7. Kalbfleisch, J.D. and Prentice, R.L., 1980, The Statistical Analysis of Failure Time Data, John Wiley & Sons, New York.

ACKNOWLEDGEMENTS

This research was sponsored by the Radiation Effects Branch of the United States National Cancer Institute under Grant number R01 CA46296. The author thanks Dr. Steven J. Samuels for beneficial statistical advice and Chengxian Gao for data processing and preparation of illustrations.

Rayonnements, Cancérisation humaine et Radiorésistance Ionizing radiation, Human Carcinogenesis and Radioresistance

Monique Vuillaume et Eric Quéinnec

URA 686 CNRS, Ecole Normale Supérieure, 46 rue d'Ulm, Paris, France, Cedex 05.

RESUME

Les espèces activées de l'oxygène sont mises en cause dans de nombreux phénomènes inflammatoires, dans la transformation cellulaire et la carcinogénèse. Toutes les expériences qui ont étudié : (i) leur influence directe; (ii) ou indirecte *in vivo*, et/ou, sur culture de cellules se sont révélées positives.

A contrario, les réactions, ou les produits, qui diminuent le taux de ces espèces activées, soit directement, soit indirectement par une augmentation des activités SOD, catalase, et peroxydase, limitent les anomalies énoncées ci-dessus. C'est le cas du domaine "2" (porteur du cuivre) de l'hémocyanine du scorpion (i) qui possède les trois activités de défense cellulaire, (ii) dont les activités oxyphorique, SOD, catalase et peroxydase résistent à au moins 4000 Gy, et qui de ce fait, participe à la radiorésistance exceptionnelle de cet animal.

ABSTRACT

H₂O₂ and free radicals are correlated with inflammatory diseases, cellular transformation and carcinogenesis. Experiments studying their direct or indirect influence (*in vivo*, and/or, in cell cultures were still positive.

In the contrary, reactions or products, which decrease level(s) of free radicals/H₂O₂ (i) directly, (ii) indirectly by an increase of SOD, catalase and peroxydase activities zeroed the above described phenomena. It is the case of the domain number 2 (that contains copper) of the Scorpion's blood pigment (hemocyanin), (i) which possesses SOD-, catalase- and peroxydase-like properties, resistant, at least, at 4000Gy, furthermore explaining the especially high radioresistance of scorpions.

INTRODUCTION

La majeure partie de l'oxygène respiré est consommée durant la phosphorylation oxydative des mitochondries. Cependant 8 à 10% échappent dans un métabolisme normal, à la réduction totale à 4 électrons (H₂O). Les radicaux libres (O₂^{•-}, OH[•]) et les molécules d'H₂O₂ ainsi obtenus sont potentiellement très toxiques pour la cellules. D'autres réactions biologiques normales conduisent également à la production, dans le cytosol, les mitochondries et près du DNA, de ces espèces activées .O₂^{•-}, OH[•], H₂O₂ sont également produites par l'action des radiations ionisantes naturelles ou artificielles qui selon l'énergie distribuée conduisent à une radiolyse totale ou partielle de l'H₂O. Des systèmes enzymatiques présents dans les cellules/tissus peuvent minimiser leurs dommages (1-5) : ce sont les peroxydases, les catalases et les superoxydes dismutases. Ces

enzymes ne fonctionnent plus lorsque le taux de leurs substrats respectifs excède leur capacité enzymatique. et ne pourront assurer qu'un service réduit en cas de débordement pathologique.

D'où l'intérêt de travailler sur des systèmes cellulaires, et/ou, pathologies humaines bien définies, où la production/ accumulation anarchique d'une ou plusieurs de ces différentes espèces est soupçonnée. Parmi quelques exemples, je citerai certains de nos propres travaux qui ont mis en évidence certaines des relations pouvant intervenir entre différents systèmes défaillants, (DNA repair, activité catalase anormale) et les tentatives de réparation spontanées par le biais d'une augmentation de l'activité d'une autre enzyme (par exemple l'activité glutathion peroxydase). Cette présentation n'est évidemment pas exhaustive et ne choisit que certains exemples portant sur certaines étapes de la cancérogénèse humaine. En contre partie, je citerai brièvement un exemple de radiorésistance naturelle exceptionnelle, l'hémocyanine du scorpion) pour laquelle nous avons mis en évidence, aussi bien dans la protéine purifiée que dans ses sous-unités (monomères et domaines 75 et 50 KDa) des activités de type SOD, catalase et peroxydase, résistant à au moins 4000 Gy .

RESULTATS

I) AGENTS EXTERNES /CONDITIONS produisant des espèces activées de l'oxygène .L'oxygène hyperbare, les peroxydations lipidiques, les intermédiaires quinoniques, des mimétiques des réactions de type-Fenton, des modifications dans le transport des électrons le long de la chaîne des cytochromes, des réactions redox en présence de métaux, des molécules chimiques utilisées dans les traitements des obésités, la fumée de cigarette, les extraits de cafés, les radiations ionisantes (UV, X, γ , α , β , électrons) sont tous générateurs des espèces activées de l'oxygène.(6)

II) EFFETS DES RADICAUX LIBRES ET DE L'H₂O₂ (7-25)

Les premiers effets remarquables ont été sur les chromosomes/DNA. Je citerai aussi, les corrélations naturelles qui existent entre la carcinogénèse humaine , les dommages du DNA et les maladies héréditaires radiations-ionisantes dépendantes que sont *Xeroderma pigmentosum*, *Ataxia telangiectasia* , le Syndrome de Bloom, l'anémie de Fanconi, le syndrome de Cockayne .Les effets des espèces activées de l'oxygène et de leur protection par addition de SOD, et/ou catalases,et/ou, peroxydases, ont été étudiés sur des cultures de cellules, sur des organes *in toto* ,(duodénum de rat)(9) etc....Dans tous les cas, un effet inhibiteur de la "transformation " a été constaté lorsque les systèmes enzymatiques cités ci-dessus pouvaient fonctionner normalement; des coupures sur les DNA et jusqu'à la formation de tumeurs cancéreuses dans le cas contraire. Parmi les maladies génétiques non radiations dépendantes, on peut citer la trisomie 21; en effet, Sinet *et al* ont, en 1975,(12) montré que les fibroblastes, lymphocytes et monocytes de ces malades produisent une overdose de CuZnSOD . Cela a été considéré comme une des origines possible de l'accroissement de stress oxydatifs conduisant aux nombreuses anomalies métaboliques qui atteignent ces malades (rappelons que les mongoliens font un taux anormalement élevé de leucémies).

Le fait que l'activité catalase (i) ne s'effondre pas ; (ii) que l'activité glutathion peroxydase augmente dans un bon nombre de composés sanguins, paraît cependant assez peu compatible avec cette théorie.

Les relations entre "production de radicaux libres, de peroxyde d'hydrogène et d'oxygène singulet" ont été également envisagées dans bon nombre de cas.(15). Nous mêmes avons démontré qu'une maladie génétique récessive et autosomale, (16-17) UV-dépendante, *Xeroderma pigmentosum*, est caractérisé par une chute très précoce et progressive de l'activité catalase de la peau : de 20% dès l'âge de 6 mois et sans signe clinique d'apparition de la maladie, à 95% au moment de la formation des premières tumeurs cancéreuses (dès l'âge de 2-3 ans). Ce phénomène s'accompagne, après irradiation UV des extraits acellulaires, d'une augmentation par 2-3 du taux normal de l' H_2O_2 . Un traitement externe avec de la catalase de mammifère gèle l'évolution de la maladie.(18-19).

Fort de ces résultats établis sur des malades et leur famille après un suivi de 6 ans, nous avons voulu savoir si cette chute de l'activité catalase était caractéristique :

(1) de la peau, et/ou, des ses fibroblastes et kératinocytes en culture de XP, d'autres maladies génétiques sensibles aux radiations ionisantes (*Ataxia telangiectasia*, syndrome de Bloom ...); (20-22)

(2) d'autres systèmes de même origine embryonnaire, mais non-radiations dépendants (cancers du col de l'utérus, du vagin et de la vulve) contaminés ou non par Papillomavirus; (23)

(3) de fibroblastes et kératinocytes en culture, transformés par différents virus à DNA; (24)

(4) de cancers d'origines inflammatoires (vessie, maladie de Lapeyronie).

Dans tous les cas nous avons trouvé une diminution très précoce (même dans les cellules en culture d'origine embryonnaire) de cette activité (70-95%) et une augmentation très marquée de la quantité d' H_2O_2 formée (2-3 fois la normale) après irradiation UV. Un point remarquable est qu'il n'y a pas de parallélisme entre l'effondrement de l'activité catalase et le degré de possibilité de réparation du DNA. Par contre, il paraît y avoir :

(a) **synergie** entre les % de diminution de ces deux activités, la précocité d'apparition de la maladie et le pronostic de survie, mais, de toutes façon

(b) **cancérisation**, seulement un plus tard dans la vie de l'individu lorsque seule l'activité catalase est diminuée;

III) ENZYMES DE DEFENSE ET RADIORESISTANCE. (25-26)

Une pigment transporteur d'oxygène, l'hémocyanine de scorpion, est depuis longtemps mis en cause dans la radiorésistance exceptionnelle de cet animal. Nous avons montré que cette protéine multimérique, à Cu^{2+} et Zn^{2+} de $2 \cdot 10^6$ Da de PM, ainsi que ses sous-unités possèdent : une **activité de type catalase**, une **activité de type SOD** qu'elles conservent même après irradiation de 4000 Gy.

L'étude moléculaire de l'hémocyanine dans le cadre de la radioprotection a été abordée par le biais des travaux actuels sur les séquences d'hémocyanines d'Arthropodes:

a) la réalisation d'une sonde spécifique au(x) gène(s) hémocyanine a demandé la recherche d'une séquence conservée dans les différentes sous-unités protéiques. La séquence:His-His-Trp-His-Trp-His remplit ces caractéristiques et semble, de plus, impliquée dans la structure du site actif. Une séquence de DNA complémentaire au mRNA a donc été synthétisée afin de servir de sonde pour rechercher le messenger de l'hémocyanine.

b) La purification des RNA messagers et leur hybridation avec la sonde oligonucléotidique spécifique, a permis de déterminer la taille du (ou des) messenger (s) de l'hémocyanine. Le cDNA correspondant à l'hémocyanine a été cloné. Son expression dans des systèmes eucaryotes devrait permettre :

1) l'étude de la "réparation" éventuelle des systèmes déficitaires cités ci-dessus par un fragment de petit poids moléculaire,

2) ainsi que de l'éventuel transfert de la radio-résistance de l'hémocyanine à différents systèmes cellulaires.

CONCLUSIONS

Les produits de réduction de l'oxygène obtenus aussi bien au cours du métabolisme normal que lors de réactions pathologiques paraissent entrer très activement en jeu dans la mise en place de la transformation cellulaire, et/ou de la cancérisation. En contre partie, la radio-résistance naturelle du scorpion qui est de plus de 1000 fois supérieure à celle de l'Homme est en majeure partie portée par son pigment sanguin natif (l'hémocyanine, protéine de 2.10^6 KDa) et ses sous-unités (75 et 53 KDa) qui possèdent tous des activités de type catalase, SOD et peroxydase, dépendant du Cu^{2+} dans le site actif du domaine 2; Ces activités résistent à au moins 4000 Gy. L'obtention en grandes quantités de ,

REFERENCES

1. Mc Cord, J.M., and Fridovitch, I., 1969, J.Biol. Chem., 244, 6049-6057
2. Frew, J.E., and Jones, P. 1984, Adv. Inorg. and Bioinorg. Mechanisms, 3, 175-212
3. Chance, B., Sies, H., and Boveris, A. 1979. Physiol. Rev., 59, 527-605
4. Chaudière, J., Gérard, D., 1988, Dosage de l'activité glutathion peroxydase , dans "biologie des Lipides chez l'Homme"
5. Flohé, L. 1989. The selenium glutathion peroxidase. dans "Glutathion" Dolphin et al edit., 644-731
6. Vuillaume, M., 1987, Mutation Res., 186, 43-72
7. Cerutti, P.A. 1985. Science, 227, 375-381
8. Wong, H.W., Elwell, J.H., Oberley, L.W. 1989, Cell, 58, 923-931
9. Ito, A, Watanabe, H., Naito, M., Kawashima, K. 1984. Gann, 75, 17-21
10. Imlay, J.A. and Linn, S. 1989. Science, 240, 1302-1309
11. Sinet, P.M., Michelson, A.M., Bazin, J., Lejeune, J. 1975. Biochem. Biophys. Res Comm., 67, 910-915
12. Zimmerman, R. and Cerutti, P. 1984, Proc. Natl. Acad. Sci. USA, 81, 2085-2087
13. Liotti, F.S., Bodo, A.R., Menghini, M. Bruschi, G. 1987. Intern. J Cancer, 40, 354-357

14. Fuchs, J., Huflejt, M.E., and Packer, L. 1989. Photochem. Photobiol., 50, 739-744
15. Kawanashi, S., Inoue, S., Yamamoto, K. 1989. Humana Press, 21, 367-372
16. Dodet, B.1991, Biofutur, mai 1991, 23-34
17. Cleaver, J.E., and Bootsma, D. 1975. Ann. Rev. Genet., 9, 19-38.
18. Vuillaume, M., Decroix, Y., Calvayrac, R., Vallot R. and Best-Belpomme, M. 1983. C. R. Acad. Sci. Paris, 296, 845-850.
19. Vuillaume, M., Calvayrac, R., Decroix, Y., Goyffon, M., and Best-Belpomme, M. 1983. Nuclear General Review, 6, 465-472.
20. Vuillaume, M., Calvayrac, R., Best-Belpomme, M., Tarroux, P., Hubert, M., Decroix Y., and Sarasin, A. 1986. Cancer Res., 46, 538-544.
21. Vuillaume, M., Lafont, R., Jouve, H., Hubert, M., Calvayrac R., and Best-Belpomme, M. 1989. Bioelectrochem. Bioenergetics., 19, 541-556.
22. Vuillaume, M., Best-Belpomme, M., Lafont, R., Hubert, M., Decroix Y., and Sarasin, A. 1989. Carcinogenesis, 10, 1375-1381.
23. Vuillaume, M., Decroix, Y., Calvayrac, R., Truc, J.B., Paniel, B.J., Vincens, P., Tarroux P., and Poitout, P., 1991. International J. Gynecol. Pathol., sous presse.
24. Rabilloud, T., Asselineau, D., Miquel, C., Calvayrac, R., Darmon M., and Vuillaume M. 1990. Intern. J. Cancer, 45, 952-956.
25. Huyart, N., Calvayrac, R., Goyffon, M., and Vuillaume, M. 1983. Comp. Biochem. Physiol., 76B, 153-159.
26. Vuillaume, M., Ducancel, F., Rabilloud, T., and Goyffon, M. 1988. Comp. Biochem. Physiol., 92B, 17-23.
27. Quéinnec, E., Gardés-Albert, M., Goyffon, M., Ferradini, C. and Vuillaume, M. 1990, Biochim. Biophys. Acta, 1041, 153-159
28. Quéinnec, E., Gardés-Albert, M., Ducancel, F., Goyffon, M., Ferradini, C. and Vuillaume, M. 1991. J. Biophys. JECR 1990.
29. Quéinnec, E. 1991. Activités anti-oxydantes de l'hémocyanine du scorpion *Androctonus australis*. Thèse de Doctorat d'Université, Paris VI, 12 avril 1991.

REMERCIEMENTS.

Le travail sur le rôle de l'hémocyanine dans la radiorésistance du Scorpion a été subventionné par EDF-Radioprotection, France, et La Société Française de Radioprotection

TRANSFER OF RISK COEFFICIENTS ACROSS POPULATIONS¹

Len R. Rasmussen

Radiation and Industrial Safety Branch
Whiteshell Research Laboratories
Pinawa, Manitoba Canada

ABSTRACT

The variation of lifetime risk projections for a Canadian population caused by the uncertainty in the choice of method for transferring excess relative risk coefficients between populations is assessed. Site-specific projections, varied by factors up to 3.5 when excess risk coefficients of the BEIR V relative risk models were transferred to the Canadian population using an additive and multiplicative method. When the risk from all cancers are combined, differences between transfer methods were no longer significant. The Canadian projections were consistent with the ICRP-60 nominal fatal cancer risk estimates.

INTRODUCTION

Current lifetime risk estimates of cancer mortality following exposure to ionizing radiation are based almost entirely on the Life Span Study of the Japanese survivors of the atomic bombings of Hiroshima and Nagasaki. As a result of the latest follow-up of cancer mortality of the cohort (1950-1985), the relative risk model has become preferred over the absolute risk model for projecting lifetime cancer risks following radiation exposure (ICRP 1991, NRC 1990, UNSCEAR 1988, Shimizu et al. 1988). The use of the relative risk model introduces the question of how to transfer excess relative risk coefficients to other populations, such as Canada, where baseline cancer rates are substantially different from those in Japan.

There are two plausible risk transfer methods. The first is a multiplicative method whereby excess relative risk coefficients are transferred directly and applied to the baseline cancer mortality rates of the population of interest. The second is an additive method whereby the excess relative risk coefficients are first applied to the baseline rates of Japan and then the resulting excess absolute risk coefficients transferred to the population of interest. Presently, there is no general agreement on which, if any, transfer method should be used or whether the same method should be used for every cancer site (ICRP 1991).

The purpose of this paper is to assess the variation in the projected lifetime risk of fatal cancer per unit dose for a Canadian population caused by the uncertainty in the choice of risk transfer method. Variations are compared with statistical errors in the excess relative risk coefficients caused by sampling variation. In addition, Canadian projections are compared with the nominal fatal cancer risk coefficients derived in ICRP publication 60, the 1990 Recommendation of the ICRP (ICRP 1991).

¹This paper is based on a M.Sc. thesis report (Rasmussen 1991) commissioned by the Atomic Energy Control Board of Canada.

METHODS

Lifetime risk projections for the Canadian population are performed using the excess relative risk coefficients of the modified relative risk models developed by the BEIR V Committee (NRC 1990) of the respiratory tract, female breast, digestive system, and other remaining organs and tissues. Projections are performed for a single hypothetical whole body exposure of 1 Sv and projections are averaged over the life-table age distribution of a 1982 and 1988 Canadian population with equal number of male and females. A dose and dose rate effectiveness factor of 2 is assumed.

The additive risk transfer method uses the baseline cancer mortality rates of the 1984 Japanese population² to compute the conditional absolute excess risks. The multiplicative method uses the baseline cancer rates of 1982 Canada (StatCan 1985) and 1988 Canada³. A Canadian life-table is constructed using age-specific mortality rates for all causes of death in Canada for 1980-1982 (StatsCan 1985b) and 1988. Approximate 90 percent confidence intervals representing the uncertainty due to sampling variation are calculated indirectly by multiplying the ratio of the upper and lower 90% confidence interval of the excess lifetime risk point estimate given in the BEIR V report (NRC 1990) to the Canadian projected lifetime fatal cancer risk. The Canadian projections are compared to the ICRP-60 nominal risk factors by combining the ICRP site specific values to give the corresponding groupings in the BEIR V report⁴.

COMPARISON OF BASELINE CANCER MORTALITY RATES IN CANADA AND JAPAN

Table 1 shows the standardized⁵ sex and site specific cancer mortality rates for Canada and Japan. The annual background risk of cancer mortality are similar between Canada and Japan for leukemia, Canadian rates being higher by about a factor 1.07. For other cancers, baseline rates differ substantially between the populations. Cancers of the respiratory tract, female breast, and other remaining cancers are greater in Canada than Japan by factors of about 2, 4, and 2 respectively. For digestive cancers, the Canadian baseline mortality rate is about half the rate in Japan. The differences in site-specific baseline rates between Canada and Japan tend to be offsetting so that overall, the rate for all cancers combined is similar between Japan and Canada (Canadian rates higher by a factor of 1.2).

RESULTS

Table 2 shows the age- and sex averaged⁵ site-specific risks of fatal cancer per Sv for the Canadian population. Given is the lifetime fatal

² Supplied by Dale Preston of the Radiation Effects Research Foundation

³ The 1988 Canadian rates were calculated using data from 1988 causes of death tables and population estimates supplied by Statistics Canada

⁴ Standardized to the age distribution of the 1988 Canadian population.

⁵ Averaged over a Canadian life table population (ages 0-85) and equal number of males and female

cancer risk averaged over transfer methods (the nominal risk estimates) the variation with transfer method, the 90% confidence interval of the nominal estimates, and the nominal values given by the ICRP. For cancers of the respiratory tract, female breast, and other remaining cancers the multiplicative transfer method gives a significantly higher projected risk than additive method by factors of 1.8, 3.5, and 2.4, respectively. For digestive cancer, the fatal cancer risk projected by the multiplicative method is almost half that of the additive method. These variations are comparable to the uncertainty caused by sampling variation (i.e. 90% confidence intervals). The projected lifetime risk for radiation induced leukemia is similar between transfer methods, differ by a factor of 1.14. The site-specific differences between transfer methods tends to be offsetting so that when the lifetime risk from all radiation induced cancers are combined, there is little difference between transfer methods (transfer methods differing by a factor of 1.18).

The site-specific lifetime risk projections for the Canadian population are in good agreement with the nominal fatal cancer risk factors given in ICRP publication 60 (ICRP 1991). For specific cancer except leukemia, the ICRP risk factors within the range projected by the two transfer methods for Canada. The ICRP risk factor for radiation-induced leukemia mortality is lower than that for Canada (ICRP: 50×10^{-7} per Sv, Canada: 70 to 80×10^{-4} per Sv). However, this is not significant in view of the uncertainty due to sampling variation and the ICRP do not use the BEIR V risk coefficients.

CONCLUSION

The choice of method for transferring excess relative risk coefficients is a significant source of uncertainty in lifetime risk projections of fatal cancer resulting from radiation exposure. Canadian site-specific projections can be expected to vary up to a factor 3 or more, depending on the transfer method and cancer site. In view of the difficulty in choosing between transfer methods and the significant effect on site-specific risks, it would seem the appropriate approach is to carry out lifetime risk projections using both methods and then average the results.

TABLE 1

NATIONAL CANADIAN AND JAPANESE STANDARDIZED* MORTALITY RATES
BY CANCER SITE (DEATHS PER 100,000 PERSONS PER YEAR)

CANCER GROUP	MALES			FEMALES		
	Canada	Japan	Ratio Can/Jap	Canada	Japan	Ratio Can/Jap
Leukemia	5.4	5.0	1.08	3.6	3.4	1.06
Respiratory	73	39	1.87	22	11	2.00
Breast	--	--	--	28	7	4.00
Digestive	61	120	0.50	36	59	0.60
Other	73	28	2.60	42	23	1.83
All Cancers	212	192	1.10	132	103	1.28

(a) Standardized to the age distribution of a 1988 Canadian population

TABLE 2

VARIATION OF THE PROJECTED LIFETIME RISK OF FATAL CANCER PER UNIT DOSE FOR
GENERAL CANADIAN POPULATION CAUSED BY THE UNCERTAINTY IN RISK TRANSFER
METHOD AND SAMPLING VARIATION.

Lifetime Risk of Fatal Cancer
(10^{-4} per Sv)

CANCER	CANADA (a)	ICRP-60 (b)	SOURCE OF UNCERTAINTY	
			RISK TRANSFER TRANSFER (c)	SAMPLING VARIATION (d)
Leukemia	75	50	70 - 80	30 - 185
Respiratory	90	85	65 - 115	60 - 135
Breast	25	20	10 - 35	20 - 35
Digestive	220	240	275 - 165	155 - 325
Other	130	105	75 - 180	90 - 190
All Cancers	540	500	495 - 575	390 - 805

- (a) Average over risk transfer method, sex, and age distribution of a 1982 and 1988 Canadian life-table population (ages 0-85)
- (b) ICRP site-specific risk estimates grouped to represent the equivalent BEIR V cancer groupings
- (c) Range of Canadian lifetime fatal cancer risk per Sv projected by additive and multiplicative risk transfer method.
- (d) 90% confidence interval of Canadian projected lifetime fatal cancer risk per Sv.

REFERENCES

- ICRP 1991. "The 1990 Recommendations of the International Commission on Radiological Protection." ICRP Publication 60. Pergamon Press, Oxford (1991).
- NRC 1990. National Research Council, Committee on Biological Effects of Ionizing Radiation (BEIR V), "Health Effects of Exposure to Low Levels of Ionizing Radiation". National Academy Press, Washington, D.C. (1990).
- Rasmussen, L.R. 1991. "Uncertainties in Lifetime Risk Projections for Radiation-induced Cancer and an Assessment of the Applicability of the ICRP-60 Fatal Cancer Risk Estimates to the Canadian Population". Thesis report. McMaster University, Hamilton Ontario, Canada (1991).
- Shimizu, Y, H. Kato, and W.J. Schull. 1988. "Life Span Study Report 11, Part 2. Cancer mortality in the years 1950-1985, based on the recently revised doses". RERF TR5-88, Hiroshima: Radiation Effects Research Foundation.
- StatCan 1985. "1982 Canada Cancer Statistics". Statistics Canada 1985.
- StatsCan 1985b. "Canada 1980-82 Current Life Tables". Statistics Canada 1985.
- UNSCEAR 1988. "Sources, Effects, and Risk of Ionizing Radiations". United Nations Scientific Committee of the Effects of Atomic Radiations, 1988 Report to the General Assembly. U.N. Publication E.88.IX.7. United Nations, New York (1988).

Augmentation of Proliferative Responses of Mouse
Splenocytes by Low Dose X Ray Irradiation

*Keiichiro Ishii, **Miyuki Ayuzawa and *Jun Misonoh

*Central Research Institute of Electric Power Industry,
2-11-1 Iwatokita Komae-shi, Tokyo 201, Japan.

**Nissei Sangyo Co., Ltd.,
26-27 Sakamachi Shinjuku-ku, Tokyo 160, Japan.

ABSTRACT

To elucidate the hormetic effect on the immune system, we studied the mitogen induced proliferation of mouse splenocytes after low-dose X irradiation. Major results obtained were as follows; Proliferative response of mouse splenocytes induced by Con A or PHA was augmented by a single whole-body irradiation with 2.5 or 5 cGy, and its optimal concentration of Con A rose to 4 $\mu\text{g/ml}$ from 2 $\mu\text{g/ml}$ in the sham irradiated control group. Furthermore, irradiation with 5 cGy prevented mouse splenocytes from declining of mitogen responses by subsequent 4 Gy irradiation.

INTRODUCTION

Radiation hormesis is a new concept for radiation biology. The concept is that low-dose irradiation stimulates bio functions¹. A phenomenon in which low-dose irradiation stimulates mitogen-induced proliferation of human T-cells in in vitro experiments has been reported². In general, however, it was well known that immune cells are easily injured by X-ray irradiation, since they are highly sensitive to X-ray. To verify the hormetic effect of low-dose whole-body X-ray irradiation, in vivo, in cells of immune system, we studied effects on the proliferative responses of mouse splenocytes induced by various mitogens. The results obtained are reported in this paper.

METHODS

Male BALB/c mice of 7 weeks old were given a single whole body X ray irradiation of 2.5 or 5 cGy at an irradiation dose rate of 1 cGy/min. SHIMADZU X ray irradiator MBR-1505R was used. Another experiment was made, where the dose was divided over 5 days, 1 cGy/day. Spleen was taken out 4 hours after the single irradiation or 4 hours after the final irradiation in the divided irradiation case. Cell suspensions were prepared.

Splenocytes were cultured on RPMI-1640 medium containing 5% fetal bovine serum under an environment of 37°C and 5% CO₂, in the presence of 1-16 µg/ml of Concanavalin A (Con A) or 25 µg/ml of Phytohemagglutinin (PHA) or lipopolysaccharide (LPS), for 44 hours. Next, ³H-thymidine was added to the culture, and cultivation was continued for 4 hours. Radioactivity taken into the cells was measured by a liquid scintillation counting system.

Some animals were irradiated with 4 Gy 21 days after the low-dose whole body irradiation of 5 cGy. Spleen was taken out 4 hours or 24 hours after the last irradiation. Response of splenocytes to mitogen was examined in the same manner.

The controls of these experiments were mice for which the low dose irradiation operation was substituted with a sham operation.

CONCLUSIONS

To conclude, our major results are as follows;

(1) As shown in Fig. 1, proliferative response of mouse splenocytes induced by Con A or PHA was augmented by a single whole-body irradiation with 2.5 or 5 cGy, whereas the proliferation induced by LPS was augmented only by irradiation with 2.5 cGy. And, the fractionated whole-body irradiation

exhibited less effect on PHA-induced proliferation than a single irradiation.

(2) Although the data is not shown in the paper, low-dose whole-body irradiation with 5 cGy prevented mouse splenocytes from declining of mitogen-induced proliferation by subsequent high-dose irradiation with 4 Gy.

(3) As shown in Fig. 2, Con A-induced proliferation of mouse splenocytes was augmented by an irradiation with 2.5 cGy over the range of 1-16 $\mu\text{g/ml}$ of Con A. Its optimal concentration of Con A rose to 4 $\mu\text{g/ml}$ from 2 $\mu\text{g/ml}$ in the sham-irradiated control group.

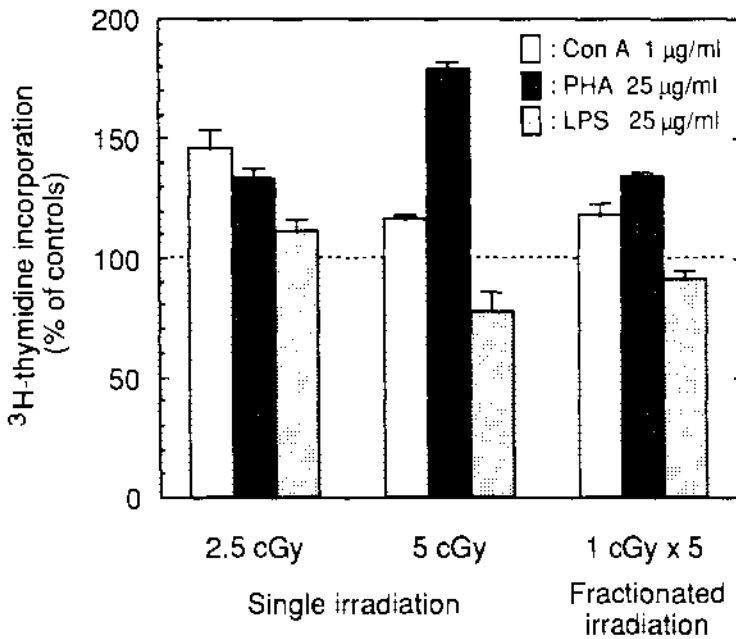

Fig. 1. Effect of a single whole-body X-ray irradiation and fractionated irradiation on mitogen-induced proliferation of mouse splenocytes. The number of mice per experimental point is 13.

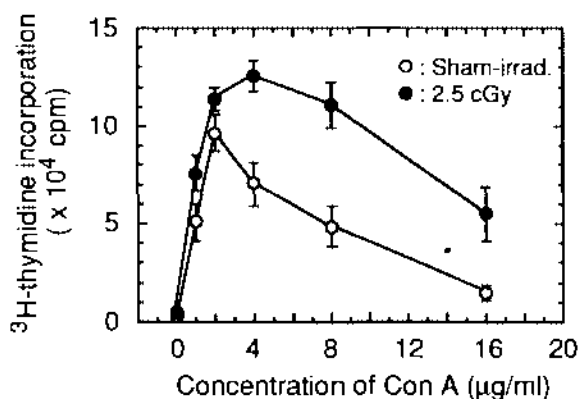

Fig. 2. Effect of a single whole-body X-ray irradiation (2.5 cGy) on Con A-induced proliferation of mouse splenocytes, as a function of concentration of Con A. The number of mice per experimental point is 12.

The augmentation of the response to mitogen in mouse splenocytes this time was also observed in F344/NSlc rats in the past³. We considered significant augmentation of mitogen-induced proliferation of mouse splenocytes by low-dose whole-body X-ray irradiation is one of hormetic effects. And, our finding suggests some functional alteration in splenocytes from low-dose irradiated mice.

REFERENCES

1. T. D. Luckey, 1982, Physiological Benefits from Low Levels of Ionizing Radiation, *Health Phys.*, 43, 771.
2. N. Gualde and J. S. Goodwin, 1984, Effect of Irradiation on Human T-Cell Proliferation: Low Dose Irradiation Stimulates Mitogen-Induced Proliferation and Function of Suppressor/Cytotoxic T-Cell Subset, *Cell. Immunol.*, 84, 439.
3. K. Ishii, N. Muro and Y. Yamamoto, 1990, Augmentation in Mitogen-Induced Proliferation of Rat Splenocytes by Low Dose Whole Body X-Irradiation, *NIPPON ACTA RADIOLOGICA*, 50, 10, 1262.

STUDY ON LEUKOCYTIC ENZYMES ACTIVITY INFLUENCED
BY IONIZING IRRADIATION

Snežana Milešić

Institute of Occupational and Radiological Health,
University clinical center of Belgrade

and

M. Jančić., S. Dodić

ABSTRACT

Both alkaline phosphatase (APL) and myeloperoxidase (MPO) activities in neutrophilic granulocytes influenced by different doses of ionizing irradiation were studied.

In individuals professionally exposed to the low doses, the enzyme activities were repeatedly determined during the period from 1986-1989. The activities of APL and MPO in patients exposed to the therapeutic irradiation were presented before, during and after the therapy.

Both alkaline phosphatase and myeloperoxidase activities were evidenced by cytochemical staining of capillary blood smears.

INTRODUCTION

Hematopoietic tissue is, according to its radiosensitivity classified into the first group.1 Therefore, routine peripheral blood analysis is a method of choice in irradiation effects monitoring. Intermittent, low doses induce no depression of bone marrow stem cells (when single doses not higher than 0.5mGy/0.5 mSV/) even during longer time intervals 2. Therefore, numeric changes of peripheral blood elements are not indicative of initial impairment in routine monitoring of patients. Intracellular enzymes are the most sensitive substances to ionizing irradiation 3. They are closely related to hematopoietic cells differentiation

and maturation 4. Alkaline phosphatase (APL) and myeloperoxidase (MPO) found in secondary and primary granules of neutrophilic granulocytes are of particular importance 5. Ionizing irradiation induces the inhibition of these enzymes in mature cells as well as its synthesis discontinuation in the course of granulocytopenia 6.

MATERIAL AND METHODS

The influence of small doses of ionizing irradiation was examined in professionally exposed workers (radiologic technicians, N= 27). The irradiation extent was evaluated according to the mean annually absorbed dose calculated on the basis of dosimetric control using thermoluminescent pastilles (TLD) for the whole period of the exposure.

The influence of high doses of irradiation may be evaluated in human model only in accidental situations, which are infrequent and unpredictable. Therefore, we conducted our study in cases of therapeutic application of high doses. In order to approximate local therapeutic application of high doses and accidental situation, we had performed experimental dosimetric evaluation of patient's total body dose by thermoluminescent dosimeters (TLD) as well as by dose measurement on Rando phantom's surface.

Alkaline phosphatase (APL) and myeloperoxidase (MPO) activities were determined by cytochemical staining of capillary blood smear 7. The activity was calculated according to the intensity of staining and expressed as a score of cell count product and stain index per 100 neutrophilic granulocytes, i.e. semiquantitatively 7, 8.

The activity of the examined enzymes in workers exposed to low-dose irradiation was determined repeatedly during the period from 1986 till 1989, and in patients therapeutically exposed to the irradiation, APL and MPO values are presented before, during and

after the therapy 8.

RESULTS AND DISCUSSION

The mean annually absorbed dose obtained for ten-year exposure period was 4.5 mGy, while for thirteen-year exposure period it was 5.59 mGy. Accordingly, professionally exposed workers continually and absorbed approximately the same, low doses.

The estimated effective equivalent therapeutical dose for the whole 6-week period of therapy was 2.6 Sv, with 1.3 Sv for the 2-week period.

AFL scor values in professionally exposed workers after 10 and 13 years of exposure were mutually compared, and also compared with the controls having 10 and 13 years of service. The results are presented at Table 1.

Table 1.

AFL scor in exposed and control groups

Observed groups	N	<u>Years of Service</u>	
		10 yrs	13 yrs
E	27	39,93	39,53
C	16	45,50	47,81
		0.62NS	0.11NS

Mean RBC scor values are identically compared and presented at the Table 2.

Table 2.

MFO scor in exposed and control groups

Observed groups	N	Years of Service	
		10 yrs.	13 yrs.
E	27	132.29	91.79
C	16	168.0	170.0
p		0.001 S	0.001 S

As it may be seen from labels 1 and 2, there was no significant difference in AFL scor in controls. Duration of exposure had no statistic significance.

MFO scor was significantly lower in the exposed workers, decreasing with the duration of exposure (Figure 2).

Table 2 reviews mean AFL and MFO scor values obtained from 18 patients, therapeutically irradiated due to the tumor for 6 weeks, before, during and after the therapy:

Table 3.

AFL and MFO scor in Therapeutically Irradiated Patients

AFL, MFO	N	Before RTh	During RTh	After RTh
X SCOR AFL	18	66.61	85.11	34.17
X SCOR MFO	18	141.77	109.20	73.0

The analysis using Paired T-test revealed: the difference between mean values of both enzymes showed significance of p 0.05, before, during and after the therapy. AFL values significantly increased during the

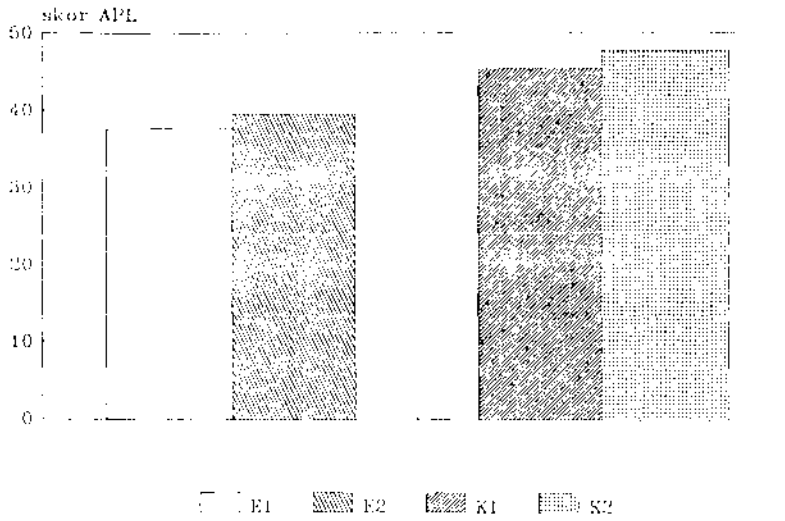

Figure 1.
APL SCOR in exposed and control group after 10 and 13 years

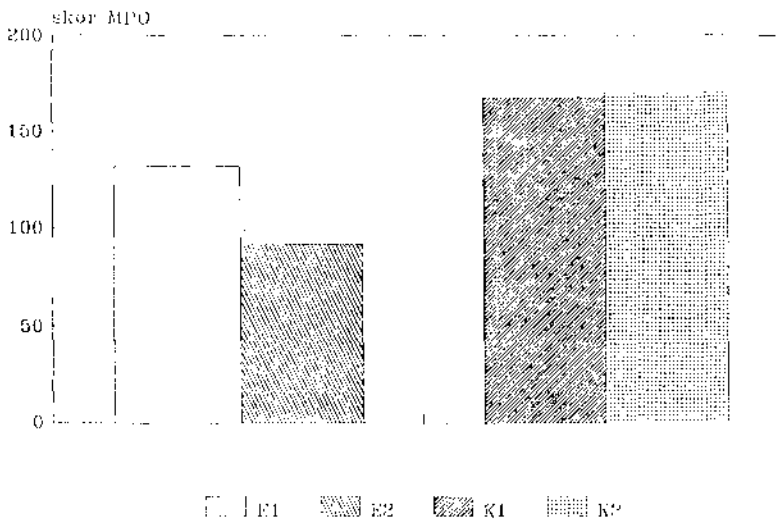

Figure 2.
MPO SCOR in exposed and control group after 10 and 13 years

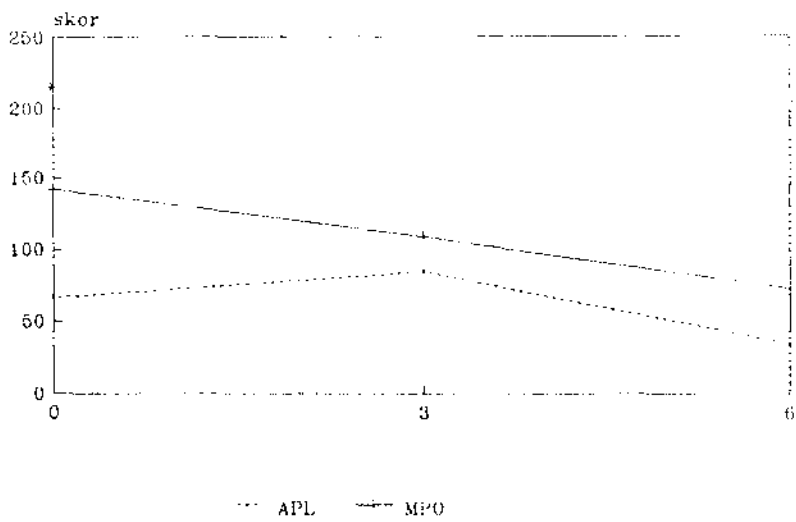

Figure 3.

APL and MPO scor tendencies influenced
 by high doses during the 6-week
 irradiation therapy

therapy, with sudden decrease after the irradiation, while significant decrease of MFO values was observed both during and after the irradiation when compared to pre-irradiation values (Figure 3).

CONCLUSION

Our results revealed significant decrease of MFO values under the influence of irradiation, while APL values decrease, influenced by low doses was insignificant. After the initial increase, significant fall was observed induced by high doses.

REFERENCES:

1. International Commission on Radiological Protection. The Evaluation of Risks from Radiation. A Report for Committee I of the International Commission of Radiological Protection and received by the Committee on April 10th, 1965 Publication 8. Pergamon Press, Oxford, (1966).
2. Cronkite EP, Bond VE, Carsten AL: Effects of low-level radiation upon the haemopoietic stem cell, IAEA-SM-266, 1964, 483-96.
3. International Commission of Radiological Protection. Radiosensitivity and Spatial Distribution of Dose, Publication 14, Pergamon Press, Oxford (1969).
4. Elizabeth N, Naparstek, E, Donnelly P, Wagner K: Persistent production of colon stimulating factor-CSF by cloned bone marrow stromal cell line D2XR11 After X-Irradiation, J. of Cellular Physiology 126:407-413, 1986
5. Jančić, M.: Diagnostic and Prognostic significance of the activity of Alkaline phosphatase in granulocytes Bull. scient. Yougoslave, T. 15, No 5-6 p.163, Zagreb maj-juni 1970.
6. Fests, K. G., Mendry, J. H. and Molineux G.: Long-Term Bone Marrow Damage in Experimental Systems and in Patients After Radiation or chemotherapy, Anticancer Research, 5:101-110, 1985.
7. Jančić, M.: Doktorska teza, Medicinski fakultet, Beograd 1969.
8. Mlađić S.: Ispitivanje aktivnosti alkalne fosfataze i peroksidaze u granulocitima periferne krvi pod uticajem jonizujućeg zračenja, Magistrski rad, Medicinski fakultet, Beograd, 1990.

PERCUTANEOUS ABSORPTION OF TRITIATED OIL AND DOSIMETRIC CONCERNS

A. Trivedi

Dosimetric Research Branch, AECL Research, Chalk River Laboratories
Chalk River, Ontario, Canada.

ABSTRACT

Tritiated oil deposited on the skin provides an intake route for organically bound tritium (OBT) and tritiated water (HTO). The kinetics of tritium excretion in the urine of hairless rats exposed to tritiated vacuum-pump oil have shown a much shorter effective time constant for OBT, compared to HTO. However, the detection of long-term tritium activity in urine indicates that there is also long-term retention in the body. This is attributed to metabolism and assimilation of tritiated compounds into the body.

INTRODUCTION

Tritium has been measured in pump oils within the vacuum pump reservoirs in tritium handling facilities [1]. A high-performance vacuum pump operating in the tritium handling facilities can retain significant amounts of tritium activity in oil and lubricants [2]. Tritium activities in the pump oils from a D-T neutron generator facility are being detected and reported as a possible source of internal contamination during maintenance of the pump systems [3].

Tritium contamination of vacuum-pump oil can result in radiation-induced polymerization of the oil. Thermal degradation and tritium radiolysis of pump fluids are considered to be critical factors in generating specific tritiated impurities. Also, tritium gas in the oil may convert to tritiated water by the catalytic effect of the emitted β -rays. This conversion becomes an important factor in contamination evaluation.

The absorption of tritium through the skin has long been recognized as a possible route of intake. Our earlier study on the skin-contact exposure to tritium-gas-contaminated metal surfaces has increased the awareness of the radiological consequences of such tritium exposures [4]. To enable improved assessment of the risk from skin contaminated with tritiated oil, the urinary excretion of tritium following the skin-contact exposure of hairless rats has been investigated. The analysis of urinary excretion of tritium is performed to evaluate the possible radiological consequences from this mode of contamination.

EXPERIMENTAL PROCEDURE

Tritiated oil was prepared by the Chemical Engineering Branch at Chalk River Laboratories. The tritium content of the oil was $31 \pm 1 \text{ mCi} \cdot \text{g}^{-1}$ ($1.2 \times 10^3 \text{ MBq} \cdot \text{g}^{-1}$). To prevent abrasion to the skin, six-month old male hairless rats (Sprague-Dawley:hy,hy) were used. The contaminated oil (28 MBq in 0.05 mL) was applied against the dorsal skin (4 cm²) to expose the animal percutaneously. The application was short (less than a minute), but the oil remained on the skin. Urine samples were collected before exposure to provide

background specimens, and were subsequently collected at regular intervals to determine HTO and OBT rates of excretion.

RESULTS AND DISCUSSION

The application of contaminated oil on the skin does not represent an acute exposure, as a thin film of contaminated oil on the skin was detected in the post-exposure examinations (within 24 h). This situation may represent a continuing exposure for the period in which a gradient of the contaminated oil exists across the skin.

Tritium in pump oil has been identified as existing in two distinct chemical states: one is tritiated organic impurities or nonexchangeable tritium (95%), and the other is tritiated water (5%).

Tritiated water in the oil should behave similarly to HTO from skin exposed to HTO vapour [5]. Thus HTO absorbed through the skin from contaminated oil should distribute uniformly throughout the body, and be excreted with a dominant single time constant. However, the urinary excretion of HTO from contaminated animals was best fit in terms of two exponentials: a fast- and a long-term component (Fig. 1). The fast component of HTO excretion was represented with an average half-life of about 3.3 ± 0.4 days (Table I). This half-life value is identical to the value of clearing component observed after skin exposure to HTO, suggesting that the HTO excreted in this component originated predominantly from the oil. The presence of a second component with half-lives of 25.5 ± 3.5 days was attributed to the fact that the turnover of HTO in the body is initially influenced by rapid absorption of tritium through the skin as tritiated water with subsequent excretion in the same form, followed by the delayed excretion of HTO as a result of catabolism of stored OBT in the body.

TABLE I Urinary Excretion of Tritium ($\text{MBq}\cdot\text{d}^{-1}$) and Biological Half-Lives (days). Values are mean of four independent animal experiments ($n=4$), and the standard deviation (S.D.) for each value is in parentheses.

Component	$U_{0,1}$	$U_{0,2}$	$U_{0,3}$	$T_{0,1}$	$T_{0,2}$	$T_{0,3}$
HTO	$2.7\text{E-}02$ ($1.5\text{E-}02$)	$2.0\text{E-}05$ ($4.7\text{E-}06$)		3.3 (0.4)	25.5 (4.0)	
OBT	$9.0\text{E-}02$ ($4.5\text{E-}02$)	$6.1\text{E-}04$ ($3.0\text{E-}04$)	$1.3\text{E-}05$ ($4.1\text{E-}06$)	1.0 (0.1)	5.4 (0.6)	31.4 (1.9)

A significant amount of OBT was also observed in urine (Fig. 1). The excretion of OBT elevated sharply and reached a maximum at 12 h. The OBT excretion in urine was analyzed in terms of three exponentials: fast-, medium- and long-term components. As shown in Table I, a much faster OBT (compared to HTO) clearing was noticed with a half-life of 1.0 ± 0.1 day. The slower

components were represented with 5.4 ± 0.6 days and 31.4 ± 1.9 days of half-lives. The amount of OBT excreted in the urine during the experimental period (for 112 days) accounted for about 75% of the total tritium excreted, whereas HTO concentration ranged between 20% and 30%.

The urinary concentrations and kinetics of tritium not only reflect the degree of percutaneous absorption of tritiated oil, but also exhibit a function of the distribution and elimination characteristics of the tritium in the body. The majority of tritium (~80%) is cleared in the urine in very early periods post-exposure (within five days). However, that fact does not account for the total applied activity on the skin. The excretion of total tritium in urine accounts only for 1% of the applied activity. The unaccountability of a large portion of tritium in urine suggests that a significant portion of tritium has: (i) been retained in the body, (ii) been lost through exhalation, (iii) been evolved from the skin, or (iv) may never have entered the body. The last seems most likely; however, the estimation and accountability of such large portions of tritium are prerequisites in developing a proper metabolic understanding.

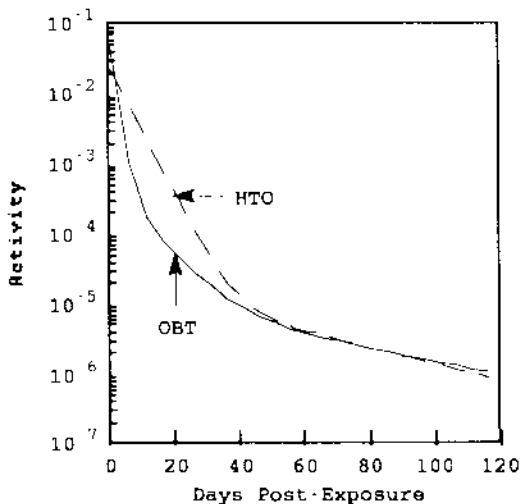

Figure 1. Urinary excretion (MBq.d^{-1}) of tritium following skin-contact exposure to tritiated oil.

The skin forms a complex barrier to external contaminants. The knowledge of the skin penetration of tritium contaminants is important. In predicting the rate at which tritiated contaminants penetrate the skin, it is necessary to consider the fundamental physiology of the skin and relate this to the possible rate-limiting steps in the permeation process. It would be useful to learn quantitatively the absorption and retention of tritium in

skin. It is thought that tritium diffuses passively in all its forms across the skin. This assumption is necessary if a simple mathematical representation of the experimental results is required for dosimetric interpretations.

Comparing the current data with our earlier work on tritium-gas-contaminated metal surfaces [4], it is apparent that the mode of contamination from two different sources results in similar tritium excretion kinetics in urine. Such observations support (but do not prove) the notion that tritium contamination from metal surfaces is due to the transfer of tritium impurities that originated external to the body and are then assimilated into the body.

CONCLUSION

It is apparent that skin-contact exposure to tritiated oil results in HTO uptake and OBT accumulation in the body. The accumulation of OBT at the point of contact in the skin and in various tissues influences the kinetics of tritium excretion in urine. The long-term retention of tritium in the body can contribute to doses to the skin and other tissues. It is therefore important to illustrate the significance of long-term retention of tritium in the body and its influence on dosimetry.

ACKNOWLEDGEMENTS

This work was financially supported by the Canadian Fusion Fuels Technology Project (CFFTP), CANDU Owners Group (COG) and AECL Research.

REFERENCES

1. Lasser, R., Klatt, K.-H and Triefenbach, D., 1987, Tritium compatibility measurements of turbomolecular pump oil. *J. Nucl. Materials* 148, 145-147.
2. Stencel, J.R., Gilbert, J.D., Griesbach, O.A. and Greco, J.M., 1988, TFTR health physics tritium measurements following D-D operations. *Fusion Tech.* 14, 1047-1053.
3. Kollar, J., Tatara, M. and Chovat, D., 1975, Tritium hazards connected with the operation of a neutron generator. *Int. J. Appl. Radiat. Isot.* 26, 635-636.
4. Trivedi, A., Leon, J.W., Barr, C.A. and McElroy, R.G.C., 1989, Skin-contact exposure to tritium on stainless-steel surfaces. In "Tritium and Advanced Fuels in Fusion Reactors" (Bonizzoni, G. and Sindoni, E., eds.), SIF, Bologna, pp. 623-631.
5. Pinson, E.A. and Langham, W.H., 1980, Physiology and toxicology of tritium in man. *Health Phys.*, 38, 1087-1110.

FUNCTIONAL STATE OF ANTIOXIDANT SYSTEM
UNDER INFLUENCE OF RADIATION LOW DOSES

I. V. Voltchek, E. V. Kostyushov, L. L. Goncharova,
I. S. Izyumtsev, V. A. Dyachek, A. A. Tyaptin,
I. N. Popov, S. A. Kalikanov, L. V. Filyov

Department of Extreme Medicine,
St. Petersburg Institute of Advanced Medical Studies,
St. Petersburg, Russia

ABSTRACT

The functional state of blood antioxidant system (AOS) was studied at liquidators of Chernobyl AES crash 4-5 years ago irradiation (200-250 mSv). The increasing SH/SS ratio in protein and non-protein thioldisulfide system, the prevailing of ascorbic acid oxiforms in plasma, changes activity of catalase, glutathionreductase and superoxidedismutase, rising of the intensity of peroxide lipid oxidation and nucleotides degradation have been revealed. Thus, the adaptational failure of the AOS may be regarded as one of the leading links in low dose irradiation injuring effect.

INTRODUCTION

It is now evident that one of the most common manifestations of the effect of stressor agents on man's organism is the intensification of free-radical oxidation processes. Obviously, this fact is to be regarded as a side effect of the growing intensity of biochemical reactions in response to the action of extreme factors, including radiation through neuro-endocrine regulation mechanisms [1]. As known, these processes are capable of exercising multiplan injuring effect on living cell.

The manifestation of the injuring effect of free radicals and peroxide compounds is hindered by the complex multicomponent antioxidant system (AOS) providing binding and modification of radicals, the prevention of peroxides formation or their destruction. In its composition are included bioantioxidants of different nature and antiperoxide enzymes [2,3]. So, pro- and antioxidant systems exist in dynamic equilibrium and provide in their interaction the adaptive reactions in response to the effect of extreme factors, ensuring radioresistance of organism [4].

MATERIALS AND METHODS

Complex clinical examination employing modern functional and biochemical methods was conducted with 35 men-liquidators of the consequences of Chernobyl AES crash 4-5 years ago radiation influence in doses 200-250 mSv per 1-2 months. The observed patients were suffered from different internal diseases (neurocirculatory asthenia, hypertensive and

ischemic heart diseases, stomach and duodenum ulcers, chronic gastroduodenitis) which have been revealed after their work in Chernobyl. The control group consists of 104 healthy donors. We studied contents of sulfhydryl (SH) and disulfide (SS) groups in whole blood [5], concentrations of ascorbic acid (AA) and its oxiforms (OF) in plasma [6]. Activity of superoxidodismutase (SOD), catalase and glutathionreductase (GR) was determined [7]. Intensity of peroxide lipid oxidation was estimated by accumulation of malone dialdehyde (MDA) in whole blood [8]. Valuing of lymphocyte products of nucleotides degradation (PND) was executed by the spectrofluorimetric method [9].

RESULTS

As the analysis of data obtained has demonstrated changes were observed in the non-enzymatic link of the AOS in low dose irradiated patients (Table).

TABLE Values of AOS in low dose irradiated patients

PROOFS	CONTROL GROUP	PATIENTS
Protein		
SH (mM/l)	13.00 ± 0.20	12.30 ± 0.20 *
SS (mM/l)	4.80 ± 0.10	3.79 ± 0.18 **
SH/SS	2.70 ± 0.20	3.81 ± 0.22 *
Non-protein		
SH (mM/l)	1.14 ± 0.01	1.35 ± 0.10 *
SS (mM/l)	0.41 ± 0.01	0.42 ± 0.10
SH/SS	2.80 ± 0.30	3.69 ± 0.29 *
AA/OF	0.84 ± 0.13	0.24 ± 0.05 *
Catalase (mKat/g)	601.7 ± 14.9	657.3 ± 34.9
GR (nKat/g)	18.5 ± 0.6	19.8 ± 1.2
SOD (% of inhib.)	29.6 ± 0.9	17.2 ± 1.6 *
MDA (μ H/l)	76.8 ± 5.1	101.8 ± 2.5 *
PND (%)	50.0 ± 8.5	70.7 ± 1.5 *

* - differences with a control group are significant (* - p<0.05, ** - p<0.01) by Fisher test

In particular, the significant disorders were observed in thioldisulfide system which displayed by increasing of SH/SS ratio both in protein and non-protein fractions of the solid blood. And if in protein part it was connected with the reducing value of SS-groups then in non-protein part it was due to significant increasing value of SH-groups.

At the same time the functional state of ascorbic redox system was characterized by the great prevailing of its oxiforms in plasma.

Changes of enzymatic function were exclusively individual: the activity of catalase and GR more often has

been increased than decreased but overall there weren't differences between the enzymatic activity of low dose irradiated patients in comparison with a control group. At the same time SOD was depressed in all observations.

On the background of data obtained the level of MDA and FND were significantly rised.

DISCUSSION

The increasing of non-protein SH-groups and enzymatic activity may testify the hormetic influence of low dose irradiation on the nonspecific resistance in the process of adaptation. From the one side, unproportional decreasing of protein SS- (to a considerable extent) and SH- groups (to a smaller extent) may be limited by structural protein alteration which are accompanied by changes of correlation between camouflage and accessible for determination protein thiol and disulfide groups. From the other side, the rising of protein SH/SS ratio may be regarded as the protective reaction at the more low adaptational level in the conditions of the oxidizing agents excess which is realized at non-protein group expence.

Even under conditions of AOS adaptative activation there aren't abilities to prevent the increasing of peroxide lipid oxidation, DNA degradation and reducing of ascorbic acid oxiforms. So, our data give reason to suggest the significant role of antioxydant insufficiency in the launching mechanisms of disease in low dose irradiation.

At the level of cell metabolism it is manifested in peroxidation reactions, whose biochemical substrate are practically all biomolekules, which leads to injuring their practically. Its consequence is disturbance of biological activity, synthesis, transport and inactivation of enzymes, hormones, vitamins, mediators and other substances, as well as change of receptivity, membrane permeability, energetic deficit, disturbance of hemoglobin transport of oxigen and its utilisation by tissue. This leads to proliferation and differentiation disorders, disintegration of humoral and cellular defence mechanisms, including the immune [10].

In its turn, the result of the changes indicated is disturbance of circulatory homeostasis system, vessel reactivity and microcirculation, heart activity, as well as disorder of pulmonary gas exchange leading to hypoxia of tissues and organs. Subsequent hemocirculatory disturbances together with tissue and cell hypoxia lead to functional and morphological modifications in organs and lifesecuring systems and to development of various organ's pathology in low dose irradiated persons.

CONCLUSIONS

For our opinion, the adaptational failure of the antioxydant system may be regarded as one of the leading links in pathogenesis of damage by radiation low doses.

The methods employed can be recommended for the estimation of radiation danger, standartization and elaboration of the directions for radioprotection. Achived results enable us to propose a pathogenetically founded metabolic therapy of injuries induced by low dose radiation with the employment of antioxidants.

REFERENCES

1. Kuzin, A.M., 1986, Structural metabolic theory in radiobiology, Moscow, 284 p.
2. Sokolovsky, V.V., 1988, Thiol antioxidants in molecular mechanisms of organism nonspecific reaction on the action of environment extreme factors, *Quest.Med.Chem.*, 34, 6, pp. 2-11.
3. Kostyushov, E.V., 1984, The role of thioldisulfide and ascorbic redox systems in late toxicosis of the pregnant, Minsk, pp. 1-20.
4. Burlakova, E.B., Ivanenko, G.Ph., Shishkina, L.N., 1985, A contribution of antioxidants and endogenous thiols to ensuring radioresistance of organism, *Proc. Acad. Sci. USSR, Ser.: Biol.*, 4, pp. 588-593.
5. Sokolovsky, V.V., Belozyorova, L.A., Ogurtsova, R.E., 1977, Method of quantative analysis of disulfide groups in blood by reverse amperometric titration, *Lab.work*, 1, pp. 26-27.
6. Sokolovsky, V.V., Lebedeva, L.V., Lielup, T.B., 1974, Separate determination of ascorbic, dehydroascorbic and diketogulonic acids content in serum, *Lab work*, 3, pp. 160-162.
7. Beutler, E., 1975, Red cell metabolism: a manual of biochemical methods, Sec.Edd. - N.Y.
8. Andreeva, L.I., Kozhemyakin, L.A., Kishkun, A.A., 1988, A modified thiobarbituric acid test for measuring lipid peroxidation products, *Lab. work*, 11, pp. 41-43.
9. Ivannik, B.P., Sin'kova, R.V., Konov, A.V., Ryabchenko, N.I., 1986, Chromatin endonucleolysis in thymocytes of irradiated and nonirradiated rats, *Radiobiol.*, 26, 2, pp. 162-166.
10. Voltchek, I.V., Filyov, L.V., Kostyushov, E.V., and co-workers, 1991, About the disorders of mononuclear antiviral resistance under influence of low dose radiation, Human immune status and radiation, All-Union Sci. Conf. (Gomel), Moscow, pp. 130-131.

LOCALISATION MOLECULAIRE DE L'AMERICIUM, DU TECHNETIUM
ET DU CESIUM CHEZ DES ANIMAUX MARINS COMESTIBLES
LEUR COMPORTEMENT METABOLIQUE ET SES CONSEQUENCES

PIERI J., F. GOUDARD et M.C. MILCENT
Laboratoire de Biochimie et Radiobiologie, Faculté des
Sciences et des Techniques, 2 rue de la Houssinière
44072 NANTES CEDEX 03

MOLECULAR LOCALISATION OF AMERICIUM , TECHNETIUM
AND CESIUM IN EDIBLE MARINE ANIMALS.
THEIR METABOLIC BEHAVIOR AND THEIR CONSEQUENCES

We show the molecular behavior of americium, technetium and cesium on the chromatographic pattern of each cytosol in the digestive gland of eel and lobster.

The contamination by cadmium seems to compete with americium in the fractions of MW 10,000.

Cesium shows an ionic behavior.

Il est actuellement connu que le radiocésium présente un comportement ionique lorsqu'il est disséminé dans l'environnement.

Notre but a été d'étudier le comportement de ce radioélément au niveau moléculaire chez un animal comestible, l'anguille, et de comparer ces résultats avec ceux obtenus pour le Tc-95m et l'Am-241 chez des animaux marins comestibles.

Le fractionnement subcellulaire a été fait sur le foie et le muscle de l'anguille, selon une méthode utilisée précédemment (Galey et al, 1986 ; Goudard et al, 1991). La radioactivité du césium se trouve essentiellement dans le cytosol : 87 % pour le foie et 79 % pour le muscle.

Le fractionnement chromatographique du compartiment cytosolique est obtenu sur Séphacryl S300 : Fig. 1 et 2.

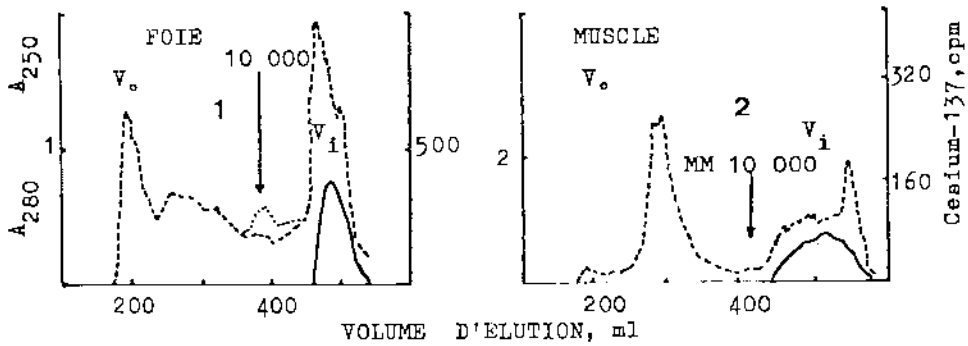
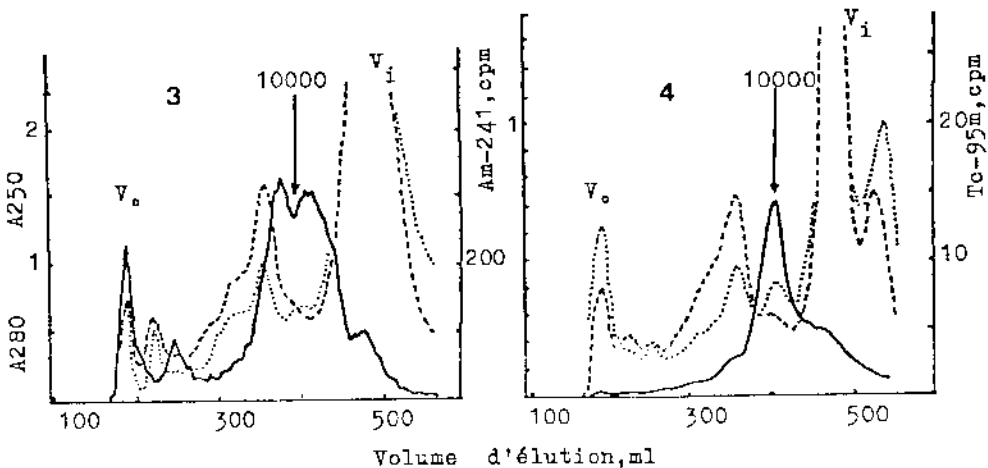

Fig. 1 et 2 - Chromatographie en gel filtration (Séphacryl S300) de cytosols de cellules de foie et de muscle d'anguille contaminés au Cs 137.



Les figures 3 et 4 nous montrent les chromatogrammes de cytosol de homards contaminés par l'Am-241 et le Tc-95m.

On note :

1 - L'activité pour les deux radioéléments est reportée sur les fractions détectées à 280 et 250 nm entre le V_0 et le V_1 , c'est à dire là où les molécules présentent un coefficient de partage.

2 - L'Am-241 est lié de façon répétitive sur la ferritine. On relève un pic très net d'activité dû au Tc-95m dans la zone de masse 10 000 (métallothionéines). Au niveau des masses molaires 10 000, la courbe d'activité de l'Am-241 présente une dépression accentuée par une induction de métallothionéine (injection de Cd-109), Fig. 5 et 6. et 7.

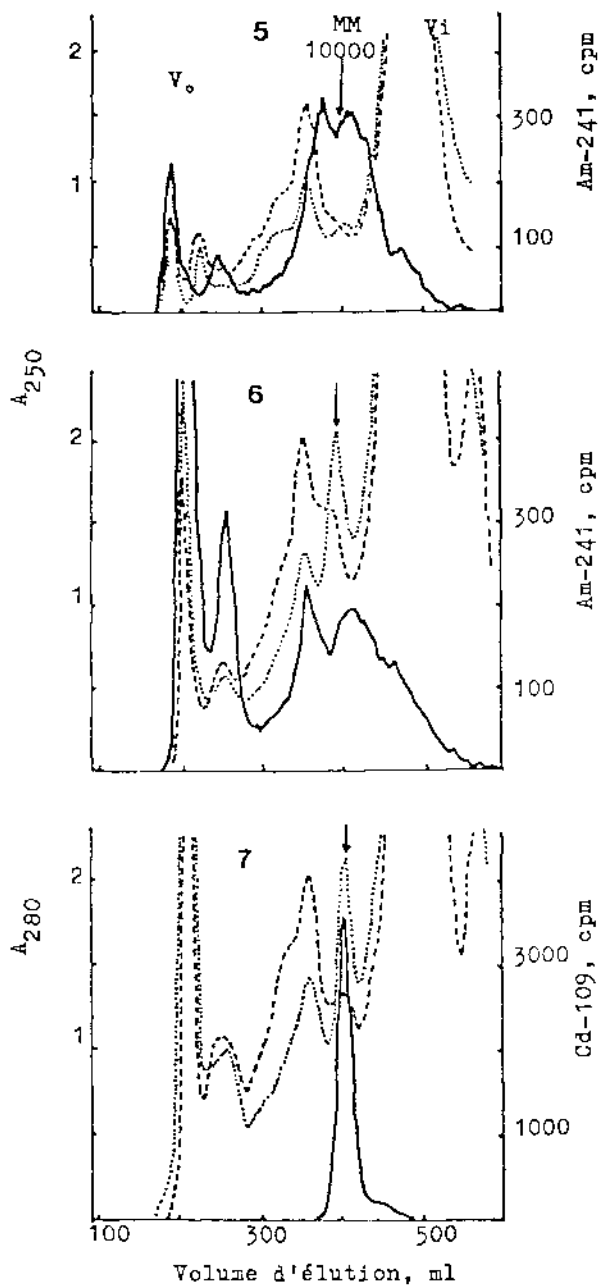

Fig. 5, 6 et 7 - Courbes d'activité de l'Am-241 dans des fractions cytosoliques sans (fig.5) et avec (fig.6) injection de cadmium chez le homard. La fig. 7 montre la place du cadmium.

L'Américium présenterait une compétition défavorable avec le métal inducteur.

Sachant que toutes les petites molécules et les ions ont une diffusion libre dans la phase stationnaire, le Vi représente ce volume. Le rapport entre l'activité dans la zone chromatographique où les protéines présentent un coefficient de partage et l'activité après le Vi peut être considérée comme un rapport de localisation métabolique. Ce rapport est assez représentatif de la diffusion d'un radionucléide dans l'organisme d'un animal contaminé. Il est très bas dans le foie de l'anguille pour le césium, ce qui montre la tendance très limitée du radiocésium à se fixer sur les protéines cytosoliques de cet organe. En comparaison, ce rapport est 500 fois plus élevé pour le Tc-95m et 2500 fois plus élevé pour l'Am-241 dans l'hépatopancreas du homard.

En d'autres termes, deux radionucléides peuvent montrer la même radioactivité au niveau cytosolique dans le foie, mais présenteraient un comportement différent selon ce rapport. Il est possible que la contamination des parties comestibles des animaux correspondrait à ces différences de rapport.

Références

- GALEY J., F. GOUDARD, J. PIERI, P. GERMAIN and S.G. GEORGE
241Am binding components in the digestive gland cells of the marine prosobranch Littorina littorea
Comparative Biochemistry and Physiology 85A, 333-340 (1986)
- GOUDARD F., J.P. DURAND, J. GALEY, J. PIERI, M. MASSON and S.G. GEORGE
Subcellular localisation and identification of 95mTc and 241Am binding ligands in the hepatopancreas of the lobster Homarus gammarus
Marine Biology, 108, 411-417 (1991).

MANAGEMENT OF RADIO FREQUENCY RADIATION EXPOSURES IN TELECOM AUSTRALIA

K.H. Joyner and B. Hocking
Telecom Australia Research Laboratories
770 Blackburn Road Clayton Victoria 3168 Australia

ABSTRACT

Telecom Australia is the largest non-military user of radio frequency radiation (RFR) in Australia and the management of risks to health from RFR exposure are discussed. The Australian RFR Exposure Standard forms the basis of risk assessment. Risk assessment and control procedures including the health surveillance of workers, other special occupational groups and members of the general public are outlined.

INTRODUCTION

Risk management principles regarding safety of workers and public were originally developed in the nuclear industry. They have been recently applied to the use of chemicals in the UK code on Control of Substances Hazardous to Health and the Worksafe Australia code on Workplace Hazardous Substances. Essentially employers are required to identify and assess risks to the health of their workforce, contractors, visitors and public arising from substances and processes, and where appropriate to control any risks. Control should mainly be by engineering or administrative actions rather than relying on protective clothing. Health surveillance is part of the control strategy. This paper extends these ideas to RFR and is based on the authors experiences in Telecom Australia, the Royal Australian Air Force and some small industries.

In order to thoughtfully assess risks from RFR it is essential to be aware of the range of possible health effects [1]; to have an understanding of the mechanisms of interaction of RFR with the human body [1] and to know the relevant safety standards that have been set. The limits permitted by the Australian RFR Exposure Standard [2] are shown in Figure 1.

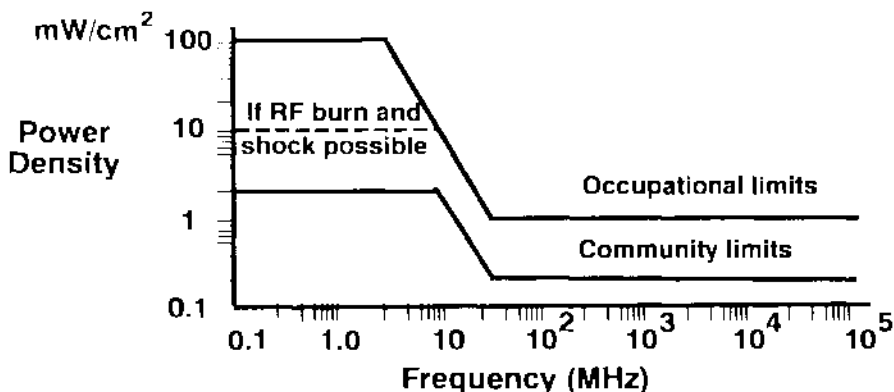

Figure 1: Australian RFR Exposure Standard

RISK ASSESSMENT AND CONTROL - OCCUPATIONAL EXPOSURES

Evaluation

The first step is to measure the exposure. Appropriate measurement procedures and instrumentation are covered in detail in [3]. Any person planning to measure RFR levels should refer to this or similar publications as there are a number of issues with which the "would be surveyor" should be familiar prior to the commencement of the survey. The results of any surveys should be recorded and updated with changes to plant or equipment. The results are then compared to the occupational level of the Australian Standard.

Control Procedures

Where the Standard is exceeded, the levels of exposure should be reduced (to at or below the relevant limit) by various control procedures. Expert advice may need to be sought. Control procedures include:

- Shield or restrict access to the source.

Shielding or isolation of the source through the use of metallic enclosures is the preferred control procedure. Where shielding is not an option, such as in the case of radio and TV broadcast antennas, access restrictions are generally the only control option.

- Reduce power.

During maintenance, a reduction in transmitter power may be an option to achieve compliance with the limits. Indeed the transmitter may have to be turned off in instances where maintenance on antennas and plant is required. Specific procedures for down-power or power-off will have to be included with safe working practices (see below).

- Safe working practices.

All safe working practices such as down-power or power-off procedures, as well as a map of restricted zones should be located in a central position. All staff should be aware of the procedures and the need to up-date this record when changes are made to the site.

- Warning signs.

Warning signs should be installed to identify areas which are off limits to the general public or to personnel, and to identify sources of RFR.

- Protective clothing.

Protective clothing should only be provided where other methods have been shown to be ineffective and where it has been established that the protective clothing is effective.

- Supervision and co-ordination.

The responsibility for supervision and coordination all of these approaches should be given to a unit or person within the organization.

To complement these procedures, training is required for staff about the hazard of RFR and the safe working practices. Special training may be required for the coordinating staff and those persons involved in the survey of RFR levels. Where contractors are working on sites with RFR sources the operator has a responsibility to inform contractors of any risks and the safe working practices to be followed.

Health Surveillance

Health surveillance of workers should be instituted if there is a significant risk of exposure above the community limits. Medical surveillance has various aims:

- At pre-employment it provides a baseline on health status and detects conditions which may be adversely affected by RFR exposures. The latter include electromagnetic interference to, and heating of medical implants (see below).

- At periodic examinations it is intended to detect adverse health effects, (such as changes in the lens of the eye).
- It should also provide medical data for epidemiological studies. (This should be in parallel with documentation on work exposure).

The Australia Standard [2] details the medical examination required for RFR workers. The records of examination need to be stored for durations set by regulatory authorities. Special occupational groups may require further management. Such groups include workers with medical implants, pregnant workers and staff accidentally over-exposed. RFR workers who have medical implants should be evaluated prior to commencing, or on resuming work [4]. Devices such as cochlear implants or pacemakers may be subject to EMI in high field strengths or at certain frequencies. Other devices such as orthopaedic prosthesis or skull plates may act as antennas and cause heating of adjacent tissue. Individual advice should be provided regarding any restrictions on duties or alterations to the work environment.

The specific absorption rate of the foetus may exceed community exposure levels when a pregnant worker is exposed to the occupational exposure limits at certain frequencies [5]. Therefore, it is prudent to reduce exposure of pregnant RFR workers to below the community exposure limit as soon as reasonably practicable for the duration of the pregnancy to ensure maximal protection of the unborn child and to ensure potential legal liabilities are met.

In the event of accidental over-exposure to RFR the following should occur:

- The circumstances causing the over-exposure should be determined and corrected.
- A biophysical investigation should proceed to determine the extent of over-exposure.
- Medical examination should be conducted utilising data on the over-exposure to direct detailed examination [6].

Good occupational risk management requires monitoring all of the above to ensure documentation of exposure levels, auditing of work practices and integration of health surveillance and accident data.

RISK ASSESSMENT AND CONTROL - PUBLIC EXPOSURES

The community may be exposed to RFR due to their proximity to transmitting antennas, industrial sources of RFR, or their use of radiocommunications products. Possible exposures should be measured and evaluated, and where required appropriate control procedures introduced.

- Community Exposure Limits

At the boundary of transmitting sites and areas within transmitting sites open to visitors the RFR levels must comply with the community exposure limits (see Fig. 1). For industrial sources of RFR (eg RF welding) barriers and warnings should be place at the boundaries where community exposure limits may be exceeded.

- RFR Products.

Radiocommunication devices or equipment, where required, will also have to comply with the community exposure limits (see Fig. 1). Clear instructions on the appropriate use of the equipment and the placement of antennas will need to be included.

- Electromagnetic Interference (EMI)

EMI generally manifests itself as the visible or audible degradation of TV or radio reception. EMI is irritating but in general, not life threatening. However, there are instances where EMI may have serious consequences, such as the disruption of air navigation services and electronic systems of aircraft, the inadvertent detonation of electro-explosive devices and ignition of flammable atmospheres. In hospitals where patients may have susceptible medical devices it is particularly important RFR fields be controlled to avoid EMI.

- Town Planning

In Australia some State Government Departments have developed guidelines for town planners in order to protect the public and to avoid disruption of RFR transmissions. These require that where development is proposed it should be critically assessed if it is within 500 m of VHF, UHF broadcast services and 1000 m of radar and HF sources, or if transmission paths may be interrupted. In addition, it has been recommended that planning authorities not approve new transmission sources which would expose the surrounding community to levels in excess of relevant Australian Standards.

- Education and Information

In addition it is desirable the public be provided with information on RFR and good public relations be fostered through the use of videos [7] booklets [8] and the lay and scientific media. McKlveen & Blitz have described a community consultation process for ionising radiation concerns [9] and Morgan & colleagues [10] have outlined the level of knowledge of lay groups about extremely low frequency radiation as a starting point for education programs. These approaches should be considered when communicating about safety of RFR between the public, generators and regulators of RFR.

CONCLUSION

Health risk management for RFR requires a coherent approach to the safety of workers and public. It is desirable that users of RFR adopt a high standard of management and risk mitigation and that personnel are aware of, and adhere to safe working practices. This paper sets out the authors experiences within Telecom and other industries. It is suggested that this paper could form a basis of a code of practice. However, it is recognised that the authors own experience is limited to certain aspects of RFR usage and therefore a wider input is needed for a code to be formed. It is also noted that the above paper is broader than some existing codes, (by inclusion of information on the management of pregnancy or accidents) and thereby indicates ways other codes may be extended to improve risk management.

ACKNOWLEDGEMENT

This paper is published by permission of the Executive General Manager Telecom Australia Research Laboratories.

REFERENCES

1. NCRP Rep. No. 6, 1986. Bethesda, MD.
2. AS2772.1-1990. Standards Australia, North Sydney, NSW.
3. AS2772.2-1988. Standards Australia, North Sydney, NSW.
4. Hocking B., Joyner K. H. and Fleming A. H., Scan. J. Work Environ. Hlth.1991;17:1-6.
5. Fleming A. H. and Joyner K. H., Telecom Australia Res.Labs. Report RLR7996,1990.
6. Hocking B. and Joyner K.H., J. Microwave Power. 1988;23:75-80.
7. Radio Base Stations - Are They Safe? Mobile Comms. Services. Telecom Australia ,1991.
8. Yost M. Non-ionizing Radiation Questions & Answers. San Francisco Press. 1988. San Francisco.
9. McKlveen J. and Blitz P., J. Occup. Hlth.Saf.:ANZ. 1990;6(6):491-501.
10. Morgan M. et al., Bioelectromagnetics. 1990;11:313-35.

RESULTS FROM AN AUSTRALIAN SOLAR UVR MEASUREMENT NETWORK AND IMPLICATIONS FOR RADIATION PROTECTION POLICY

C.R.Roy and H.P.Gies

Australian Radiation Laboratory
Yallambie, Victoria, Australia

ABSTRACT

Growing evidence of global depletion of stratospheric ozone has emphasised the need to establish an ultraviolet radiation (UVR) status and trends network, to increase our knowledge of human health effects and to better educate the public about the need to modify personal behaviour in order to minimise UVR exposure. The results presented highlight some of the difficulties that will be faced in developing a consistent approach to solar UVR protection in Australia.

INTRODUCTION

Recently there has been considerable concern over the likely depletion of the stratospheric ozone layer due to the effect of trace gases released to the atmosphere as a result of man's activities. Reports have suggested that a depletion of 2 to 3% occurred in the Northern Hemisphere during the last decade and atmospheric model calculations^{1,2} indicate possible depletions of up to 15% in the coming decades.

The development of the ozone hole in the stratosphere over Antarctica during winter^{3,4} is almost certainly due to reactions involving organochlorine chemicals⁵. Model calculations, which suggested that the breakup of the ozone hole in late spring may result in the transportation of ozone-depleted air into the mid-latitudes, have been confirmed^{6,7}.

There are indications that the numerical models are underestimating ozone loss and that ozone depletion is increasing at a rate greater than that predicted above. We are undoubtedly entering a period of increased ambient UVB with scant knowledge of the implication for plant and marine systems and for human health.

The Australian Radiation Laboratory has been making spectral measurements of UVR in Melbourne since the early 1980s. In addition broadband measurements are now made at a total of twenty locations in Australia and at the permanently-manned Australian bases in Antarctica. The aim of these measurements is not necessarily to determine long-term trends in UVR but to provide data on ambient UVR and input into epidemiological studies as well as information to help educate the public about the dangers of overexposure to UVB. Some results from the network will be presented.

EXPERIMENTAL METHOD

The radiation calibration of the network is underpinned by the spectroradiometer (SRM) system at Yallambie (38°S). This PC-

controlled system incorporates a Spex 1680B double grating monochromator with an integrating sphere input optic. The noise equivalent spectral irradiance at 300 nm is less than $1 \mu\text{W}\cdot\text{m}^{-2}\cdot\text{nm}^{-1}$. Global and diffuse horizontal terrestrial UVR over the spectral range 280-400 nm is measured at 1 nm steps with a bandpass of 1 nm on cloud-free days. Radiation calibrations are performed in-situ using a calibrated (traceable to the US National Institute of Standards and Technology) 1000 W quartz halogen lamp. Ideally an Australian network of 5 or 6 spectroradiometers would provide data to satisfy all research interests. However, available resources (both financial and human) dictated a network comprising a permanent SRM in Melbourne, a network of broadband detectors and a portable SRM for the regular field calibration of the broadband detectors.

The broadband measurement system has four radiometers each responding to the regions of the solar radiation spectrum indicated: solar radiation [0.285 - 2.8 μm], solar UVR [295-385 nm], UVB [280-315 nm] and erythemal UVR [280-340 nm].

RESULTS

The 5-day average daily total UVB for Melbourne (38°S) and Darwin (4°S), which provide the extremes of latitude on the Australian mainland, is shown in Figure 1. The data reflect the fact that Darwin has small annual changes in the solar zenith angle and ozone while Melbourne has much larger variations in both. As expected, in winter, Darwin and the other tropical locations experienced significantly higher UVB (up to a factor of eight) than the midlatitude locations. In

Figure 1. Daily total UVB for Melbourne and Darwin

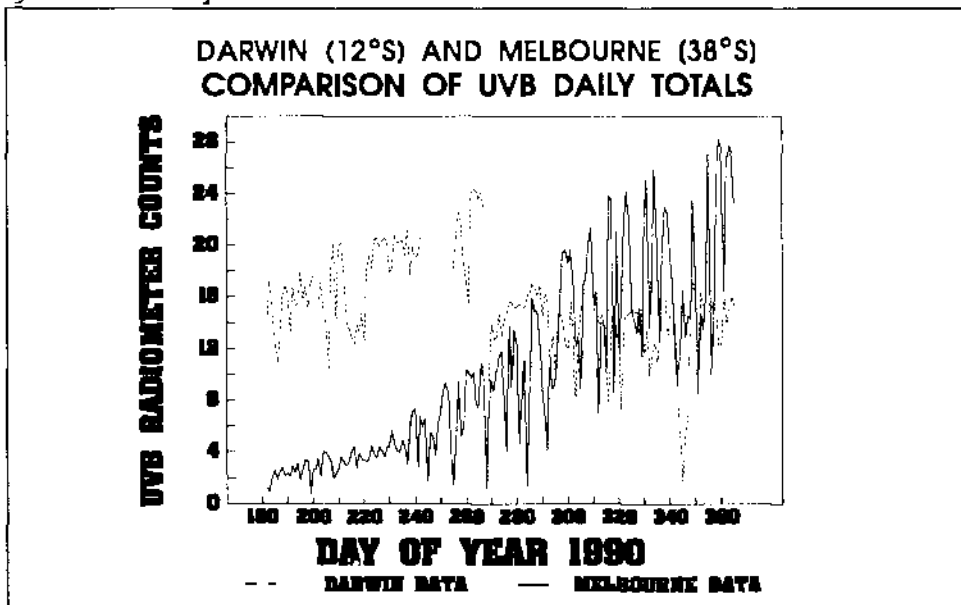
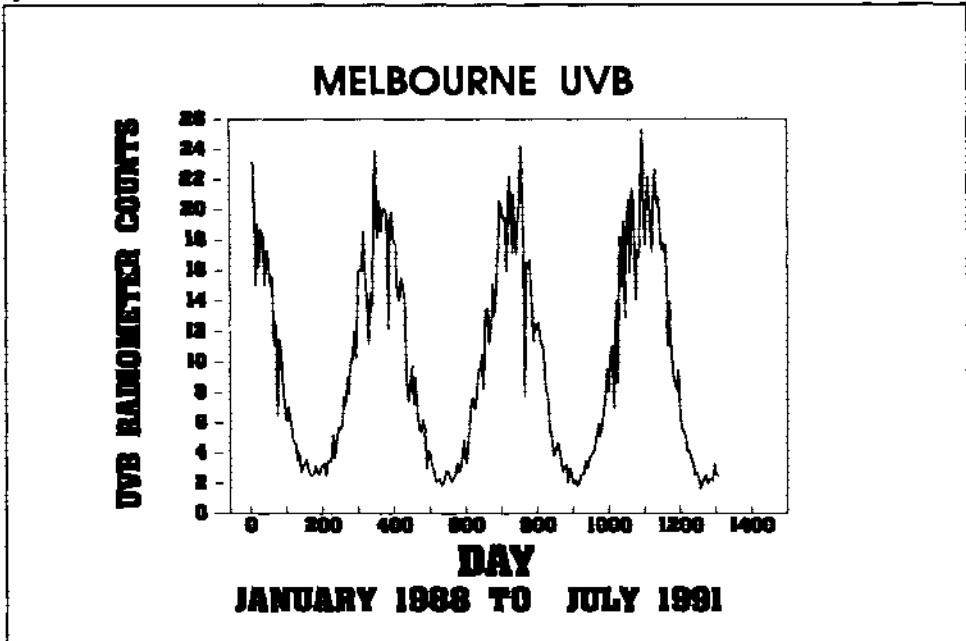

Figure 2. Melbourne solar UVB



summer there is little difference between the various sites. In Figure 2 daily total UVB for Melbourne is plotted for the 3½ year period indicated (1 count is approximately 1.6 kJ m^{-2}).

Antarctic ozone depletion can influence Melbourne ambient UVB during November/December⁷. However, total ozone measured in Melbourne during February 1991 were the lowest values on record for this period. This same period also had low cloudcover compared with recent years. These two important parameters reinforce each other and result here (Figure 3) in large increases in UVB - substantially greater than long-term ozone trends would suggest. In fact, the February 1991 UVB is 37% and 27% higher than that for 1990 and 1989 respectively.

DISCUSSION

In developing radiation protection advice for both outdoor workers and the public the considerable differences in the seasonal profiles of ambient UVB make a uniform approach impossible and advice needs to be tailored to the location.

Estimates of future ozone depletions of 3-4% per decade are alarming but if correct should provide time to pursue critical research and to develop appropriate strategies. Although short-term ozone variations have always been a natural phenomenon effects such as that seen in Figure 3 suggest that either ozone depletion is occurring at a rate substantially greater than the models are predicting or that other atmospheric processes are capable of producing substantially reduced ozone for periods of a month or more. If similar

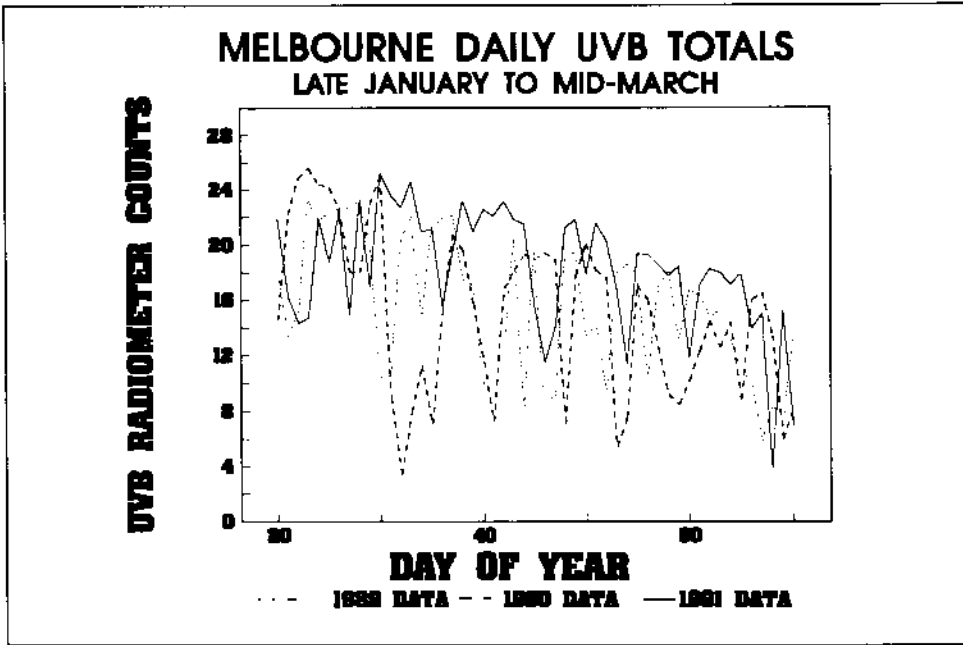

Figure 3. Comparison of Melbourne UVB for the years 1989-91.

periods of reduced ozone become a regular occurrence then it may be necessary to develop criteria on which public warnings could be based.

The current extremely high skin cancer rates in Australia is the result of past exposure to UVR. Ozone depletion will result in large increases in skin cancer rates unless the public can be convinced of the need to modify their behaviour. A national educational program is required which takes into account not only current behaviour but acknowledges that the public resides in vastly different ambient UVR regions.

REFERENCES

1. World Meteorol. Organisation, 1988. Report No.18, Geneva.
2. Stolarski, R.S., Bloomfield, P. and McPeters, R.D., 1991, Geophys.Res.Letts. 18, 1015.
3. Farman, J.C. et al., 1985, Nature, 315, 207.
4. Chubachi, S., 1986, Geophys.Res.Lett., 13, 1197.
5. Farmer, C.B. et al., 1987, Nature 329, 126.
6. Atkinson, R.J. et al., 1989, Nature 340, 290.
7. Roy, C.R., et al., 1990, Nature 347, 235.

**EXPOSURE OF ONTARIO WORKERS TO RADIOFREQUENCY FIELDS
FROM DIELECTRIC HEATERS**

Maurice E. Bitran, John M. Nishio, and David E. Charron

**Radiation Protection Service
Occupational Health and Safety Branch
Ontario Ministry of Labour**

ABSTRACT

As part of a program to assess and reduce the exposure of Ontario workers to non-ionizing radiations, stray electric and magnetic fields from 383 dielectric heaters were measured in 71 industrial establishments from 1988 to 1990. This represents a population of over 800 workers potentially exposed to radiofrequency (RF) electromagnetic fields. Electric and magnetic field strengths at the head, waist, and thigh levels of the operators, corrected by duty cycle, are presented for the different heater types surveyed. Worker exposure data and compliance with Ontario radiofrequency exposure guidelines are discussed.

INTRODUCTION

Electromagnetic energy in the radiofrequency range (1 - 100 MHz) is used in industry to heat dielectric materials such as plastics, woods, glues, fabrics, etc. Dielectric heaters, also known as RF heaters or plastic welders, usually operate at a frequency of 27.12 MHz and have output powers approximately ranging from 0.2 to 100 kW. The dielectric material to be processed is placed between the heater's electrodes, and held under mechanical pressure while the RF field is applied (usually between 0.5 and 10 seconds). The dielectric material is efficiently heated by the energy dissipated when its polar molecules oscillate under the influence of the external RF field.

Dielectric heaters are a significant source of occupational exposure to RF fields. This is the result of the intense stray fields emitted by the habitually unshielded electrodes, the close proximity of the operators to the electrodes, and a standard operating frequency very close to the resonant absorption range of an electrically-grounded adult. A number of surveys have shown that a significant fraction of RF sealer workers are exposed to field strengths in excess of applicable guidelines or standards (1, 2, 3, 4, 5). Overexposure to radiofrequency fields is known to result in a variety of health effects (6, 7, 8, 9). The Ontario Ministry of Labour guidelines limit worker exposure to $900/f^2[\text{MHz}]$ [mW/cm^2] for frequencies between 3 and 30 MHz and to 1 [mW/cm^2] between 30 and 100 MHz, averaged over 1 hour; and to 25 times the 1 hour guideline averaged over 1 second.

MATERIALS AND METHODS

Operator exposure to stray fields from dielectric heaters takes place in the reactive near field, it is intermittent, and the actual RF frequency often differs from the nominal value. In order to take these factors into account, both the electric and the magnetic fields were measured, the "on time" and the production rate of each machine were recorded, and the operating frequency was measured. Measurements were taken at approximately 10 to 15 cm from the left and right sides of the operators at the head, waist, and thigh levels. The measurements were taken while the operators carried out their normal duties at their working positions.

The field strength measurements were carried out with Narda 8616 and 8716, and Holaday HI-3001, meters equipped with broadband, isotropic electric and magnetic field probes. The frequency was measured with a Global Model 5000 frequency counter, and the "on time" was measured with a stop watch. Other information recorded included the type of heater, the nominal power output, the hourly production rate, the presence of shielding, and reports of contact electric shocks.

RESULTS

In total, 383 dielectric heaters were surveyed. The average output power and operating frequency for the different RF heater types are presented in Table I. The corresponding minimum and maximum values are listed below in parenthesis. Most of the heaters surveyed were either of the "Turntable" type (30.5%) or of the "Shuttle Tray" type (24.3%), but enough devices of each type were surveyed to ensure representative exposure averages. "Standard" heaters (general purpose heaters with a fixed work table without attachments) were divided according to the number of operators (one or two). The electric and magnetic field exposure data are presented in Table II, expressed in equivalent power densities to facilitate comparison. This table presents mean exposure levels at the head, waist, and thigh of the operators, corrected for duty cycle, for the different RF heater types. The corresponding minimum and maximum values are listed below in parenthesis. Table III presents the fractions of RF heaters found to produce operator exposure in excess of the Ontario Ministry of Labour RF exposure guidelines.

DISCUSSION

The results of this survey agree with previous findings indicating that a significant fraction of RF heater operators are exposed to high electric and magnetic field levels. Exposure levels were found to depend more on the type of heater used than on their power output. "Standard, 2-Operator" heaters produced the highest exposure levels, with exposure to the magnetic field being higher than to the electric field. Most of these heaters are used in the manufacture of pool liners or water beds. They have relatively high output powers, long "on times", and the electrodes are normally unshielded. In addition, the operators may have to support the material during

processing, and thus stand close to the sides of the electrodes and to the RF feed cables. The proximity of the operator to current-carrying cables and straps may contribute to the larger magnetic field exposure produced by this type of heater. Half of the "Standard, 2-Operator" heaters surveyed exceeded the 1 hour exposure guideline and 38.9% exceeded the 1 second guideline.

The lowest exposure levels were produced by the "Conveyor" heaters (only 3.6% exceeded the 1 hour guideline, and none the 1 second guideline). This is probably due to the greater distance between electrodes and operators allowed by automated feeding. Comparable fractions of the rest of the heaters exceeded the guidelines: 17.6% to 26.5% exceeded the 1 hour guidelines, and 2.5% to 7.8% exceeded the 1 second guideline. In general, the electric field exposure to the head was higher than to the waist and thighs, while magnetic field exposures to the waist and thigh were higher than to the head.

Control measures used to reduce worker exposure included shielding of the interaction area, reducing the production rate, and increasing the distance between the operator and the electrodes. If the material does not have to be held by hand during processing, increasing the distance is a simple and effective way to reduce exposure. This can be facilitated by relocating the controls further from the interaction area, adding a time delay to the cycle, and painting a line on the floor to indicate the high exposure areas. Compliance with the Ministry of Labour RF exposure guidelines is enforced in Ontario workplaces under a general duty clause of the Occupational Health and Safety Act.

REFERENCES

1. Stuchly, M.A., et al. Radiation Survey of Dielectric (RF) Heaters in Canada. *Journal of Microwave Power* 15(2), 1980.
2. Cox, L., et al. Occupational Exposures to Radiofrequency Radiation from RF Dielectric Heat Sealers. *American Industrial Hygiene Association Journal* 43(2), 1982.
3. Joyner, K.H. and Bangay, M.J. Exposure Survey of Operators of Radiofrequency Dielectric Heaters in Australia. *Health Physics* 50(3), 1986.
4. Erikson, A. and Mild, K.H. Radiofrequency Electromagnetic Leakage Fields from Plastic Welding Machines. *J. Microwave Power* 20(2) 1985.
5. Allen, S.G. et al. Radiofrequency PVC Welding Machines, Fields and Body Currents. *Radiological Protection Bulletin* n.120, 1991
6. Elder, J.A., Cahill, D.F. Eds. *Biological Effects of Radiofrequency Radiation*. U.S. Environmental Protection Agency. EPA-600/8-83-026F. 1984.
7. Michaelson, S.M. *Biological Effects of Radiofrequency Radiation: Concepts and criteria*. *Health Physics* 60(1), 1991.
8. Adey W.R. *Tissue Interactions with Non-Ionizing Electromagnetic Fields*. *Physiol. Rev.* Vol. 61, 1989.
9. National Council on Radiation Protection and Measurements. *Biological Effects and Exposure Criteria for Radiofrequency Electromagnetic Fields*. NCRP Report No. 86, 1986.

TABLE I
RF POWER AND FREQUENCY OF THE DIELECTRIC HEATERS SURVEYED

TYPE	NUMBER	POWER [kW]	FREQUENCY [MHz]
Turntable	117	9.6	26.4
		(3.0-30)	(16.0-31.9)
Shuttle Tray	93	10.8	25.6
		(3.0-45)	(19.7-33.0)
Standard (1 Op.)	58	6.0	26.1
		(3.0-16)	(12.4-35.0)
Standard (2 Op.)	36	8.8	25.8
		(2.0-20)	(13.0-33.4)
Sewing Machine	51	1.8	37.3
		(0.25-4.0)	(25.0-78.5)
Conveyor	28	10.7	25.6
		(1.5-22.5)	(16.7-29.0)

TABLE II
WORKER EXPOSURE TO ELECTRIC AND MAGNETIC FIELDS BY HEATER TYPE,
EXPRESSED IN EQUIVALENT POWER DENSITIES AND CORRECTED BY DUTY
CYCLE

	ELECTRIC FIELD [mW/cm ²]			MAGNETIC FIELD [mW/cm ²]		
	HEAD	WAIST	THIGH	HEAD	WAIST	THIGH
Turntable	0.4	0.4	0.3	0.2	0.3	0.4
	(0.0-4.2)	(0.0-3.1)	(0.0-2.4)	(0.0-3.6)	(0.0-2.8)	(0.0-2.4)
Shuttle Tray	0.5	0.4	0.3	0.2	0.6	0.8
	(0.0-6.0)	(0.0-3.2)	(0.0-4.8)	(0.0-1.4)	(0.0-6.3)	(0.0-9.5)
Standard (1 Op.)	1.0	0.2	0.1	0.1	0.2	0.2
	(0.0-13)	(0.0-2.0)	(0.0-2.2)	(0.0-1.2)	(0.0-1.9)	(0.0-0.9)
Standard (2 Op.)	1.6	0.6	0.3	1.5	2.7	1.4
	(0.0-13)	(0.0-5.7)	(0.0-2.2)	(0.0-11)	(0.0-13)	(0.0-9.5)
Sewing Machine	0.7	0.3	0.2	0.3	0.6	0.5
	(0.0-4.7)	(0.0-0.9)	(0.0-1.6)	(0.0-2.6)	(0.0-2.4)	(0.0-2.3)
Conveyor	0.2	0.2	0.5	0.1	0.3	0.2
	(0.0-1.2)	(0.0-2.0)	(0.0-9.6)	(0.0-0.4)	(0.1-0.7)	(0.1-0.7)

TABLE III
NUMBER OF HEATERS ABOVE GUIDELINES

TYPE	1 HOUR GUIDELINE	1 SECOND GUIDELINE
Turntable	26.5 %	2.5 %
Shuttle Tray	23.7 %	5.4 %
Standard (1 Op.)	24.0 %	6.9 %
Standard (2 Op.)	50.0 %	38.9 %
Sewing Machine	17.6 %	7.8 %
Conveyor	3.6 %	0.0 %

ELF Magnetic field distribution around power lines in an urban area

B. Heaton and H.M. McCallum
Department of Bio-medical Physics,
University of Aberdeen, Foresterhill,
Aberdeen AB9 2ZD, SCOTLAND.

Abstract

A number of epidemiology studies have drawn attention to an increase in incidence of leukaemia and other cancers among children living close to sources of ELF magnetic fields. By comparing the studies a lower limit for such an effect was estimated to be $250\text{mA}\cdot\text{m}^{-1}$.

Magnetic field measurements were made around power lines running at 275kV, 132kV and 33kV. Fields above $250\text{mA}\cdot\text{m}^{-1}$ were found as far away as 60m from a 275kV line and 15m from a 132kV power line. Fields near a 33kV power line were below $250\text{mA}\cdot\text{m}^{-1}$.

The maximum magnetic field near an electric blanket was $1\text{A}\cdot\text{m}^{-1}$ and a maximum field of $3.9\text{A}\cdot\text{m}^{-1}$ was measured in an electric train.

Introduction

The work of Savitz (1988), Wertheimer and Leeper (1979) and others has drawn attention to an increase in the incidence of leukaemia amongst children living in close proximity to sources of extra-low-frequency (ELF) magnetic fields. Contradictory work has been published by Fulton et al (1980) in which no increase in leukaemia was found in children living in elevated fields. By comparing the various studies and reworking the data it was concluded that, on balance, it was likely that an increased risk did exist for children living in such fields. It was concluded that the lower limit of the magnetic field strength for such an effect was approximately $250\text{mA}\cdot\text{m}^{-1}$ although it could possibly be lower. The $250\text{mA}\cdot\text{m}^{-1}$ level was used as a threshold to determine whether there was a group of the population potentially at risk in the urban environment of Aberdeen.

One advantage that Scotland has over other parts of the world when considering the effect of ELF magnetic fields, is that there are no power transmission lines greater than 275kV. The main power line into the Aberdeen area runs at 275kV but at the outskirts of Aberdeen drops to 132kV and then to 33kV. Before dropping to 132kV, the power line passes through a suburban area and it was there that most of the measurements were made.

The work of Savitz (1990) has drawn attention to the fact that, within most homes, there are many sources of ELF magnetic fields in everyday use. One of particular interest in Aberdeen was electric blankets, particularly electric over blankets. These can be in use for upto 8 months of the year in Aberdeen and some people will, for some of the time, sleep with them switched on. Measurements were taken in the areas close to both types of blanket and around various electrical items found in the home.

Although it was felt that no problems really existed once the overhead power line kV had dropped to 33kV, one situation was identified as being of interest where the overhead line was only at 15kV; this was the field which was created inside electric trains. The magnetic fields were measured inside a train on the Aberdeen to London route. The line is not electrified until Edinburgh, about one third of the journey, thus allowing comparative measurements to be made.

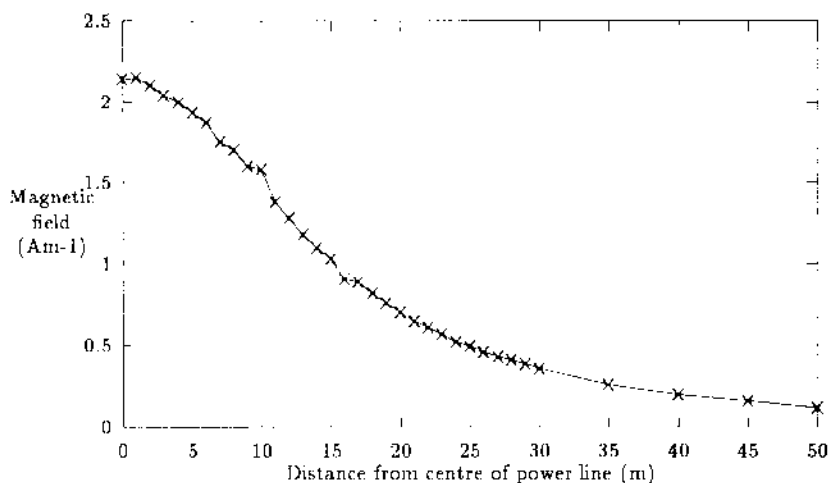

Figure 1: Magnetic field at right angles to a 275kV power line.

Measurements around power lines

Measurements were made at right angles to the power lines in autumn and summer. The summer measurements are shown in Figure 1. These were taken under a 275kV line on a warm day (for Aberdeen) at 1500 hours. Even in this situation, the distance from the centre of the line to the 250mAm^{-1} field strength boundary was upto 36 metres. Similar measurements made in autumn showed that this boundary could extend as far as 60 metres on a cold autumn evening. The strength of the field obviously depends on the current flowing through the power lines, but it was not possible to obtain numerical figures for the current. Only a subjective assessment could be made that, as the ambient temperature fell, more current would flow. Figure 2 shows measurements taken at right angles to 275kV, 132kV and 33kV power lines. Measurements taken over a week, shown in Figure 3, were made directly beneath the power line each day and showed that the field strength could vary by a factor of two. It is thought that similar measurements made in the evening could well show a much bigger variation. Although insufficient measurements were made to establish where an average magnetic field strength of 250mAm^{-1} would be situated it would not be being too pessimistic to assume a distance of 45 metres from the line. Even on this suburban housing scheme where the houses are quite widely spread, there were many well within this 45 metre distance. The cables pass twenty metres from an area health clinic and over the local primary school playground.

In the U.K. no legislation currently exists to limit the distance power cables must be from the houses.

Measurements close to electric blankets

The measurements were made with the probe positioned between a person and the blanket and at 0.1, 0.2 and 0.3 metres from it. Care was taken that no other local source of ELF magnetic field was present. Several different types of blanket were tested and all had magnetic fields in excess

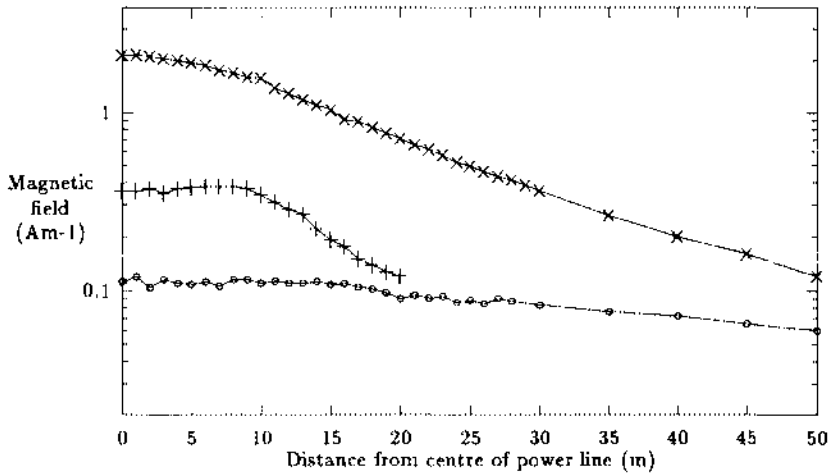

Figure 2: Magnetic fields at right angles to 275kV (x), 132kV (+) and 33kV (o) power lines.

of 250mAm^{-1} . Some rose to as high as 1Am^{-1} . The field value depended on the inter-wire spacing and the map of the wires in the blanket. In some areas the magnetic fields were found to cancel. No blankets were tested where a conscious effort had been made by the manufacturer to try to cancel the magnetic fields. The information supplied with the blankets was insufficient to easily determine which would have the higher fields and which would not.

Magnetic field levels in trains

The levels measured during the non-electrified part of the journey were low and subjectively appeared to vary with the speed of the train. The maximum field recorded at seat level was 40mAm^{-1} but this rose to 50mAm^{-1} at floor level. Once the line was electrified the magnetic field became, as one might expect, much more stable. The maximum field was recorded with the probe at right angles to the axis of the railway carriage. Measurements made on an occupied seat had a maximum of 3Am^{-1} and measurements on an empty seat a maximum of 3.9Am^{-1} . The field fell to approximately 2Am^{-1} at floor level and 1.4Am^{-1} in the central corridor 1.4 metres from the floor. Although these fields are high, one would have to travel on many train journeys to be exposed to an average field of over 250mAm^{-1} from this source. However many long distance commuters could spend 2 hours per day in these fields, and the drivers, of course, would spend much longer. The long exposures are limited to adults and little positive evidence has been established linking increases in leukaemia or other cancers in adults from exposure to fields of this order of magnitude.

Conclusion

More effort should be put into measuring ELF magnetic fields as they occur in a multitude of situations at, occasionally, surprisingly high levels. In the first instance those countries which

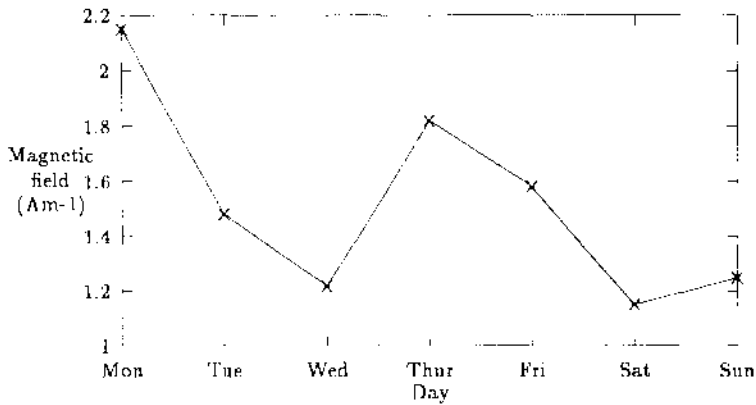

Figure 3: One week survey of the magnetic field directly beneath a 275kV power line.

do not have restrictions on the proximity of power lines to housing should seriously consider introducing them.

References

- Fulton JP, Cobb S, et al.
Electrical wiring configurations and childhood leukemia in Rhode Island.
Am. J. Epidemiol. 111:292-296,1980.
- Savitz DA, John EM et al.
Magnetic field exposure from electric appliances and childhood cancer.
Am. J. Epidemiol. 131:763-73,1990.
- Savitz DA, Wachtel H et al.
Case-control study of childhood cancer and exposure to 60Hz magnetic fields.
Am. J. Epidemiol. 128:21-38,1988.
- Wertheimer N, Leeper E.
Electrical wiring configurations and childhood cancer.
Am. J. Epidemiol 109:273-284.

OCULAR EXPOSURE TO ULTRAVIOLET AND VISIBLE RADIATION FROM LIGHT SOURCES

Maila Hietanen

Institute of Occupational Health
Laboratory of Physics
Helsinki, Finland

ABSTRACT

Exposure of the eyes to UV radiation and blue light of artificial light sources and the sun was evaluated. A spectroradiometer was used to determine the spectral irradiance at 1 nm intervals from 250 to 800 nm. Various groups of workers are at risk of ocular over-exposure to optical radiation. Outdoor workers maintenance personnel of bright light source as and wear eye-protectors with effective filtering of UV radiation and blue light.

INTRODUCTION

Normally, the human eye is not subject to prolonged bright visible radiation, since it is protected by the blink reflex and head movement. However, in certain situations bright light sources are situated so that high irradiances fall directly upon the the face and the eyes. To be able to work under such uncasual conditions, people have to overcome the natural aversion response. In the present study, spectroradiometric and photometric measurements weighted by various biologic functions were used to estimate ocular exposure to ultraviolet and visible radiation from three types of artificial light sources and the environmental solar radiation.

MATERIALS AND METHODS

In addition to the sun, study material included low-power tungsten halogen spotlights, fluorescent tubes for photostimulation, and photofloods in television and theatres. The main criterion for selecting the objects was a high probability of directly looking at the light source.

A portable spectroradiometer (Optronics 742) was used to determine the spectral irradiance and radiance of UV and visible radiation (250 to 800 nm). The detector attached to the monochromator was a photomultiplier tube. A digitally controlled stepping motor provided automatic wavelength scanning at 1 nm intervals. The spectroradiometric instrumentation was controlled by a microcomputer (Toshiba 3200).

The threshold limit values (TLVs) of the American Conference of Governmental Industrial Hygienists (ACGIH) for occupational exposure of the eyes to UV-radiation and blue light were used to evaluate the exposure of the eyes. In addition to these well-known occupational

recommendations, a biological action spectrum proposed by the International Committee on Lighting (CIE) was applied to UV radiation measurements.

RESULTS

The biologically weighted irradiance and radiance of the lamps studied were highest for photofloods used in TV studios. The unweighted UV-A irradiances varied from 1 to 38 W m^{-2} and the biologically weighted effective irradiance E_{eff} from 0.01 to 6.9 $\mu\text{W cm}^{-2}$. Particularly high values were recorded for metal halide lamps emitting strongly in the UV region. Correspondingly, the blue-light radiances L_B ranged from 0.02 to 1.9 $\text{W cm}^{-2} \text{sr}^{-1}$. The recommended daily exposure times varied from a few minutes to several hours depending on the type of the photoflood. The stage lighting systems studied were equipped with relatively low-power halogen lamps, so that the emitted optical radiation was insignificant at the realistic exposure distances.

UV irradiance and blue-light radiance of a few tungsten halogen spotlights measured at a distance of 1 m are summarized in Table 1. The calculated safe direct viewing times are based on the ACGIH limits for blue-light radiance.

Table 1. Ultraviolet irradiance and blue-light radiance of six various tungsten halogen lamps with the corresponding safe direct viewing times.

Lamp	Power	$UV_{\text{CIE}} (\text{Wm}^{-2})$	$L_B (\text{Wm}^{-2}\text{sr}^{-1})$	t_{max}
A.	50	13	750	1 h
B.	50	2.3	6070	3 min
C.	20	25	890	19 min
D.	50	17	1667	10 min
E.	100	5.4	3417	5 min
F.	150	3.8	2171	8 min

The UV irradiance and blue-light radiance measured from phototherapy lamps were lower than the recommended limits for ocular exposure (Table 2).

Table 2. UV irradiance and blue-light radiance of three photostimulation panels at a distance of 0.5 m.

Source	Distance	UV _{CIE} (Wm ⁻²)	L _B (Wm ⁻² sr ⁻¹)
A.	1.5 m	5.8x10 ⁻⁵	10.4
B.	0.5 "	8.7x10 ⁻⁴	13.9
C.	0.7 "	1.3x10 ⁻³	13.5

A few examples of the results of solar measurements on sunny days in Finland are listed in Table 3.

Table 3. Solar UV radiation and blue-light measured on various days of a year in Helsinki (60°N). E_B and L_B are the blue-light weighted irradiance and radiance.

Source	UV _{CIE} (Wm ⁻²)	E _B (Wm ⁻²)	L _B (Wm ⁻² sr ⁻¹)
Sun	0.063	72	-
Sun	0.127	93	-
Snow ^a	0.023	-	6.8
Ice ^a	0.025	-	9.7

^a reflected solar radiation

An example of the typical UV spectrum of the solar reflections from fresh snow is shown in Fig. 2.

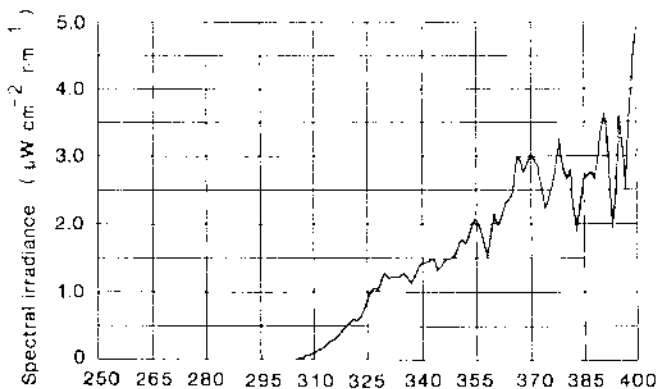

Fig. 1. UV irradiance of the solar radiation reflected from the snow.

CONCLUSIONS

The group of people subjected to the highest exposure is the maintenance personnel working near lamp sources. Also, outdoor workers (fishermen, farmers, personnel of skiing centers) are at the risk of chronic ocular over-exposure. Effective eye-protectors are necessary in such situations, especially if strong after-images are frequently produced.

Ocular exposure of phototherapy light sources is equal to the maximal environmental load of the eyes. Hence, the benefits and risks should be thoroughly considered, until the chronic effects of bright light will be unquestionable known.

Also in future revisions to the occupational and environmental safety standards the risk of ocular damage involved in chronic exposure should be carefully estimated.

REFERENCES

1. American Conference of Governmental Industrial Hygienists, 1990, Threshold Limit Values and Biological Exposure Indices for 1990-1991, Cincinnati, Ohio.
2. Commission International de l'Eclairage (CIE), 1987, Research Note of a Reference Action Spectrum for Ultraviolet Induced Erythema in Human Skin, CIE Journal, 6, pp. 17 -22.
3. Hietanen, M.T.K. and Hoikkala, M.J., 1990, Ultraviolet Radiation and Blue Light from Photofloods in Television Studios and Theaters, Health Physics, 59, pp. 193 - 198.
4. Hietanen, M., 1990, Spectroradiometric and Photometric Studies on Ocular Exposure to Ultraviolet and Visible Radiation from Light Sources, Ph.D. Thesis, University of Helsinki, Finland.
5. Marshall, J., 1985, Radiation and the ageing eye, Ophthalmol Physiol Optics, 5, pp. 241 - 263.
6. Sliney, D.H. and Wolbarsht, M.L., 1980, Safety with Lasers and Other Optical Sources, A Comprehensive Handbook, Plenum Press, New York.

**THRESHOLD LIMIT VALUES FOR ULTRAVIOLET RADIATION
MEASURED FOR SOURCES USED IN RESEARCH EQUIPMENT
AND SOME CASES OF OVEREXPOSURE TO UV RADIATION**

A.G. RICHARDS
RADIATION PROTECTION SERVICE
UNIVERSITY OF LEEDS
UNITED KINGDOM

ABSTRACT

The standard for occupational exposure to ultraviolet radiation is based on the Threshold Limit Values (TLV) published by the American Conference of Governmental Industrial Hygienists. These TLV are relative to a monochromatic source of radiation at 270nm. The exposure at this wavelength in 8h is 30 Jm^{-2} and the effective irradiance which will produce this exposure in 1 milliwatt m^{-2} . TLV have been measured for a range of ultraviolet sources used widely in educational establishments. Some cases are given of over exposure resulting in 5 - 35 Threshold Limit Values being received to the face and eyes.

INTRODUCTION

The Occupational Exposure Standard for protection against ultraviolet radiation adopted in the United States of America and accepted by the United Kingdom Health and Safety Executive for protection against ultraviolet radiation was produced by the American Conference of Governmental Industrial Hygienists (ACGIH).

The standard¹ which applies both to the skin and eyes is based on the threshold limit value for the eyes, and whilst it overprotects the skin of most individuals it should protect the eyes satisfactorily.

ACGIH Recommendations for the actinic region 200 - 315 nm

The TLV vary with wavelength. TLV for the actinic ultraviolet region 200-315nm are shown in Table 1.

Maximum permissible exposure for 8 hours at 270 nm = 30 Jm^{-2} (Compare this with a threshold² for Infra Red exposure of the cornea of $6 \times 10^4 \text{ Jm}^{-2}$)

$\lambda \text{ nm}$	TLV Jm^{-2}	S_{λ}
200	1,000	0.03
220	250	0.12
240	100	0.30
260	46	0.65
270	30	1.00
280	34	0.88
290	47	0.64
300	100	0.30
310	2,000	0.015
315	10^4	0.003

The effective irradiance for the ultraviolet source is defined by the following equation

$$E_{\text{eff}} = \int E_{\lambda} S_{\lambda} d\lambda \text{ in } \text{Wm}^{-2}$$

E_{λ} = Irradiance at wavelength

S_{λ} = Relative spectral effectiveness (relative to 270nm)

$d\lambda$ = Wavelength interval of

E_{eff} = Effective irradiance relative to a monochromatic source at 270nm

The effective irradiance for a period of 8 hours in 1 milliwatt m^{-2} . The exposure time in an eight hour period for other values of effective irradiance is given by

$$t(\text{secs}) = \frac{30}{E_{\text{eff}}(\text{Wm}^{-2})}$$

The relative spectral effectiveness S_{λ} is the factor which allows for the differing biological sensitivity of the skin and eyes against λ . S_{λ} is based on data determined for primates, rabbits and human exposure of the eye near the threshold.

ACGIH Recommendation for UVA region 315-400nm

1989-90 proposals for the TLV for the UVA region are as follows

λ nm	TLV Jm^{-2}	S_{λ}
315	1×10^4	0.003
320	2.9×10^4	0.001
330	7.3×10^5	0.00041
340	1.1×10^5	0.00028
350	1.5×10^5	0.0002
360	2.3×10^5	0.00013
365	2.7×10^5	0.00011
370	3.2×10^5	0.000093
380	4.7×10^5	0.000064
390	6.8×10^5	0.000044
400	1×10^6	0.000030

Measurement of Effective Irradiance and Threshold Limit Values

The effective irradiance can be determined by two methods

- (i) Measuring the irradiance at Wavelength λ multiplying this by S_{λ} and integrating this product over the spectral output of the lamp:
- (ii) Measuring the effective irradiance directly using an instrument where response matches the relative spectral effectiveness curve defined by ACGIH.

The International Light Radiometer 1L730A³ is an instrument that will, using a suitable detector, measure the effective irradiance directly for the region 200-315nm.

The detector used to undertake the measurements below was a type PT171D which is essentially a vacuum photodiode with a filter assembly. The detector response ideally should match the relative spectral effectiveness curve (S_{λ}) of ACGIH.

Sources of ultraviolet radiation and their outputs.

The equipment has been grouped into categories.

Low output (1 - 100) x TLV

Hilger Atomic absorption spectrometer		2 x TLV
Hilger DC Spectrograph with carbon-graphite electrodes		40 x TLV
Hilger DC Spectrograph with carbon-graphite electrodes		17 x TLV
Amnisco Colorimeter Hg lamp F4T4 BL		6 x TLV
Desaga UVIS Chromatogram Viewer Sylvania F85T/BLB lamp(10cm)		80 x TLV

Medium Output 100 - 1000 TLV

Isco UV flow monitor		168 x TLV
Philips Hg Type MB/U 400W	(25cm)	800 x TLV
Philips Hg Type MLU 300W	(25cm)	600 x TLV
Pen-ray UV Mineralight Hg lamp	(20cm)	160 x TLV

High Output > 1,000 TLV

Hanovia Portable Chromatolite Hg lamp with filter in place at (4cm)		2,500 TLV
with filter removed at (4cm)		26,000 TLV
Hilger Spectrograph Fe electrodes		2,600 TLV
Camag Universal Lamp (Sylvania G8T5) with filter (4cm)		3,400 TLV
no filter (4cm)		15,000 TLV
Desaga UVIS Chromatogram Viewer G8T5 (Germicidal lamp) 254		1,400 TLV
Hanovia Alpine Sun Lamp	(50cm)	8,000 TLV
Parker Printing Plate Machina		3,500 TLV
Sterilising Cabinet Philips TUV 30w Germicidal lamp	(25cm)	6,000 TLV
Philips TUV 15w lamp	(25cm)	1,600 TLV
Sterilisation Cabinet Sylvania G15T8	(25cm)	3,300 TLV

UV Microscopes

The output from UV microscope depends on the lamp and its power. The lamps are enclosed but leakage of UV may take place from the lamp housing. The leakage is usually low in intensity or is inaccessible and hence the hazard is small.

Occupational Over Exposure of Ultraviolet Radiation

Case 1

This involved a worker using a high intensity Hg/Xenon lamp. The lamp was housed inside an apparatus at about 2 metres from the floor some leakage took place. No estimate of the worker exposure could be made he sustained a small erythema on his forehead.

Case 2

An electrician was asked to replace a fluorescent tube in a sterilisation cabinet. The cabinet contained a visible light fluorescent tube and a germicidal UV lamp TUV 30W. The electrician worked for a period of about 15 minutes unaware that the UV lamp was switched on. Later the same day he suffered severe photophobia and photokeratitis. Subsequently it was estimated that the effective irradiance was 1.2 W m^{-2} which corresponds to an exposure time of 25 seconds in an 8 hour period. The electrician thus received about 35 x TLV.

Case 3

A research technician was working with a clean air cabinet containing a UV germicidal lamp (TUV 30w). The technician worked for a period of about 20 minutes during which time her eyes were probably about 170 mm from the lamp and it was estimated that the effective irradiance was $1.4 \times 10^{-1} \text{ Wm}^{-2}$. The technician suffered slight erythema of the skin of the face and mild irritation of the eyes. It was estimated the worker received about 5 x TLV.

Conclusions

Some equipment measured doses have a potentially hazardous high level output of UV radiation. Control of such sources of radiation is needed. The cases of over exposure considered suggests that the threshold limit values given by ACGIH are set at a reasonable value.

References

1. Threshold Limit Values and Biological Exposure Indices for 1989-1990 published by the American Conference of Governmental Industrial Hygienist Cincinnati, Ohio, ISBN 0 - 936712 - 81- 3.
2. Evaluation of Ocular Hazards Due to Electric Arc Flash at an in-line switch B.R. Chou and A.P. Cullen. Health Physics Vol. 61 No. 4 p473-479, 1991.
3. International Light, Incorporated Newburyport, Maryland, MA 01950USA.

RADIO FREQUENCY RADIATION (RFR) EXPOSURES FROM MOBILE PHONES

**K.H. Joyner, V. Lubinas, M.P. Wood, J. Saribalas
and J.A. Adams***

**Telecom Australia Research Laboratories
770 Blackburn Road, Clayton Victoria
*Department of Physics,
University of Canterbury, Christchurch, New Zealand.**

ABSTRACT

Measurements of the free space levels of radio frequency radiation (RFR) around a hand-held mobile phone and the specific absorption rate (SAR) induced in the ocular region of a phantom head exposed to RFR from a mobile phone are presented. The level of RFR measured 5 cm from the antenna of a mobile phone transmitting 600 mW was 0.27 mW/cm². The average SAR level measured in the nearside eye of the phantom head containing tissue equivalent jellies was 0.7 W/kg for a 600 mW transmit power which is very much less than the spatial peak limit of 8 W/kg underlying the Australian and other national and international RFR exposure standards.

INTRODUCTION

In Australia the Telecom cellular mobile phone network is expanding rapidly with the total number of customers exceeding 300,000. The hand-held mobile phone transmits on frequencies between 825 and 845 MHz and has an output power of 600 mW. Questions associated with RFR exposure have been raised in the media and, in one report, the use of a mobile phone was likened to placing one's head in a microwave oven. Clearly such a claim is ludicrous as the hand held mobile phone has a transmit power of 600 mW and radiates into all space, whereas a microwave oven operates at around 600 W and radiates into a confined space.

Australian and IRPA Standards for Mobile Phones

Both the Australian [1] and IRPA [2] Standards contain exclusions for devices with output powers of less than 7W and transmission frequencies of less than 1000 MHz. The exclusions, although not explicitly stated in the Standards, are based upon a spatial peak limit for the specific absorption rate (SAR) of 8 W/kg averaged over any 1 gram of tissue. As stated earlier, the hand-held mobile phones in use in Australia have maximum radiated power of 600 mW and transmission frequencies of between 825 and 845 MHz and as such are excluded from compliance with both the Standards. If these exclusions did not appear in the Standards then for members of the general public, the appropriate limits of RFR exposure to be observed at 835 MHz would be 0.2 mW/cm² for the Australian Standard and 0.42 mW/cm² for the IRPA Standard.

EXPERIMENTAL MEASUREMENTS

Measurements were made of the free space levels of RFR in the vicinity of the antenna of a mobile phone. These measurements were conducted in a semi anechoic chamber with the mobile phone mounted in a vertical position on a wooden support 1.75 m above the ground. The mobile phone was configured to transmit a full 600 mW of continuous power. A Narda 8616 broadband monitor and Narda 8621C isotropic broadband probe (0.3 to 26 GHz), mounted on a wooden support 1.75 m above the ground, were used to measure the levels of RFR at various distances from the antenna. The following levels were recorded:

Distance From Antenna (cm)	Power Density (mW/cm ²)
0	0.39
1.0	0.33
2.5	0.32
5.0	0.27
7.5	0.21
15.0	0.10

Within distances of 7.5 cm from the antenna, the level of 0.2 mW/cm² recommended in the Australian Standard [1] for members of the general public is exceeded. However, in the normal mode of operation the antenna is unlikely to be closer than 7.5 cm to the eye. In any case exposures within 7.5 cm would only be of concern if there was no exclusion clause. The free space levels of RFR are not of concern for the IRPA Standard because they are below the limit values irrespective of the exclusion clause.

Energy Absorption in Eye of Phantom Head

In the Australian context it is possible for confusion to exist between the exclusion clause in the Standard [1] and the observation that the free space levels of RFR close to the antenna of a mobile phone exceed the recommended limit for members of the general public. Therefore, it was decided to conduct a series of measurements on a phantom head and actually measure the SAR in the ocular area. The ocular area was chosen as the primary site of investigation because of the limited ability of the eye to dissipate heat relative to the brain, and the possibility of local field enhancement in the orbit due to resonance.

The phantom head was fabricated to simulate as closely as possible the electrical characteristics of a real head. Consequently, artificial tissues for eye, muscle, brain, skin and fat were developed having the same conductivity and relative permittivity as their real counterparts. The tissues were applied to a plastic replica skull which, was found to have electrical properties closer to living bone than a dried human skull. The following electrical properties

corresponding to the various tissue types were used in the experiment.

Tissue	Relative Permittivity	Conductivity (mS/m)
eye [3]	70	1900
muscle [4]	59	1190
brain [5]	44	940
skin [6]	35	590
fat [7]	5.7	60

In order to measure the electrical properties of these mixtures at 835 MHz a technique has been adapted which relies on measuring the input admittance of a monopole antenna inserted into the medium under test. The complex permittivity and hence relative permittivity and conductivity are obtained from the measured admittance as they are functionally related according to the antenna modelling theorem [8].

Both an electric (E) field probe and a temperature probe were used in the experiment. The E-field probe was manufactured specifically for the task. It consisted of an 11 mm (tip-to-tip) dipole and an HP 2207 diode mounted across the centre gap. The dipole was angled at 54.7° to the probe handle such that when the probe handle was rotated through each of three 120° sectors an isotropic response was achieved. The dipole elements of the E-field probe were encased in a 4 mm coating of epoxy. This was to physically protect the dipole and to reduce any artificial enhancement of the probe output when inserted in tissue due to increased capacitive coupling between the dipole elements. The probe was then calibrated in air. The temperature probe used was a Luxtron Fluoroptic probe model 1000A which has a 0.1°C resolution.

During the experiment the mobile phone was placed along side the head in a normal manner and measurements made in the nearside eye. The SAR was calculated from the measured E-field level using the relationship $SAR = \sigma E^2 / \rho$ where σ is the conductivity and ρ the density of wet tissue (1000 kg/m³).

A number of measurements of the SAR were made and the average value obtained was 0.7 W/kg for a transmit power of 600 mW. If we scale up from 600 mW to the figure of 7 W which is used in the exclusion clause [1, 2] we find the scaled SAR corresponds to 8.2 W/kg which is in very good agreement with the spatial peak limit of 8 W/kg underlying the exclusion clause.

No temperature increases could be measured in the phantom with the Fluoroptic probe which indicates that any rise in a real head must be less than 0.1° C. An interesting point is that a 3mm sheet of polystyrene foam had to be used as a thermal barrier in order to shield the phantom head from heat generated by the electronic circuitry of the phone.

Temperature rises in the eye corresponding to the induced SAR were numerically calculated by applying the well known

bioheat equation to a finite element model of the eyeball. The model was axisymmetric about the optic axis and consisted of 64 triangular and 166 quadrilateral elements. The thermal conductivities used for the major structures of the eyeball were 0.58 W/m/°C for the cornea, sclera, aqueous humour, iris and ciliary body 0.40 W/m/°C for the lens and 0.603 W/m/°C for the vitreous humour [7]. The external heat loads to the anterior surface of the eyeball exposed to air were evaporation at 60 W/m² and convection and radiation to an ambient temperature of 20°C at a combined heat transfer coefficient of 16 W/m/°C. Convective heat transfer from the posterior surface of the eyeball to the blood flow of the choroid was set at a heat transfer coefficient of 67 W/m²/°C to a blood temperature of 37°C. Internally the respective blood flow in the iris and ciliary body was characterised as transferring 270 X 10³ and 416 X 10³ W/m³ per degree C difference from the blood temperature of 37°C, as per the heat sink term in the bioheat equation.

Steady state analyses were conducted on the model when the eyeball was uniformly loaded at 0.75 W/kg SAR and on the normal unirradiated eye. The maximum temperature difference between the two conditions was 0.07°C in the vitreous humour. The maximum temperature rise in the lens was 0.05°C around the posterior pole.

CONCLUSIONS

The level of RFR measured 5 cm from the antenna of a mobile phone transmitting 600 mW was 0.27 mW/cm². This level of RFR has been shown to produce an average SAR of 0.7 W/kg in the ocular region of a fabricated skull. The subsequent maximum temperature rise in the eye has been calculated to be 0.07° C. On the basis of these results the general exclusion for devices operating at less than 7 W and with transmission frequencies of less than 1000 MHz is justified. It can also be concluded that the use of hand-held mobile phone does not present a health risk.

REFERENCES

1. AS2772.1, 1990. Standards Australia, North Sydney, NSW.
2. IRPA/INIRC. Health Physics, 1988;54;115-123.
3. Guy, A.W. IEEE Trans. Microwave Theory Tech., 1971;MTT-19(2);205-214.
4. Kraszewski, A. et al. Bioelectromagnetics, 1982;3;421-432.
5. Thurai, M. et al. Bioelectromagnetics, 1985;6;235-242.
6. Grant, J.P. et al. Phys. Med. Biol., 1988;33(5);607-612.
7. Cleveland, R.F. and Athey, T.W. Bioelectromagnetics, 1989;10;173-186.
8. Pham, A. Telecom Aust. Res. Labs. Rep. RLR 8078, 1991.
9. Scott, J.A. Phys. Med. Biol., 1988;33(2);227-241.

ACKNOWLEDGEMENTS

This paper is published by permission of the Executive General Manager Telecom Australia Research Laboratories.

Observed occupational radiofrequency and microwave radiation exposures during surveys around a few scientific, industrial and medical sources

R.N.Sachdev, N.A.Ingle, G.Swarup and K.K.Rajan
Environmental Assessment Section
Bhabha Atomic Research Centre
Trombay, Bombay 400085

Abstract

This paper summarizes the results of a few near electric field safety surveys conducted around radiofrequency and microwave radiation (RFMR) generating equipment. Field levels observed under actual working conditions have been graded into three categories. In the first category are the diathermy units. In the second, are inductively coupled plasma atomic emission spectrometers, crystal growing furnaces and feeder lines of the broadcasting transmitters. In the third category are surveillance radars and TV transmitters. Fields around plastic sealing machines vary widely.

Introduction

During the last few years there has been growing realization that occupational exposure to RF radiation in the lower frequency range, from health consideration, is of the same importance as that from MW. In this paper the observed electric field strengths in the vicinity of equipment have been graded and interpreted in the light of existing exposure limits¹. The instrument used for measurement of electric field in RF and MW region is model B611 radiation monitor of Narda make working in conjunction with probes B662B and B621C.

Main observations and Discussion

Salient observations on the electric field strengths observed around the equipment along with the frequency, power and distance of measurement are given in Table 1. Bathymetric representation of the field generated by operation of two furnaces in a single hall has been plotted as given in figure 1.

Below operating frequencies of 10 MHz electric and magnetic fields are required to be measured separately¹. In this study, however, measurements were confined to electric field strengths alone in all the cases². The fields observed in case of diathermy-unit surveys³ have been listed according to the part of the body being treated. It is seen that field as high as 776 V/m has been observed at a distance of 10 cm from the applicator plates. The farthest spot with appreciable field of 168 V/m is at 30 cm in the case of knee treatment. Occupational exposure limit for the 10-400 MHz slab which is relevant for the units operating at 27.12 MHz is 61 V/m. The observed fields are high when compared with a value of 17

mW/cm² at a distance of 15 cm reported elsewhere⁴.

It is clear from the bathymetric representation of the field around two crystal growing furnaces in a single working area that fields created by individual operation fall rather sharply and do not superimpose each other. In spite of the fact that power dissipated in one of the units is 2.5 times that in the other, the highest observed electric field strength is of the same level.

Concluding Remarks

It is concluded from the above study that high fields in most cases are confined to distances close to heating electrodes, radiating element or applicator plates. Awareness about high fields in close proximity and the knowledge that unnecessary exposures are to be avoided would go a long way in reducing exposure. When an instrument is under repair, inadequately shielded and inappropriately terminated, it can be a source of high leakage⁵. It is imperative that a programme of safety studies and survey around equipment generating RFMR be kept alive.

References

1. International Non-Ionizing Radiation Committee of the International Radiation Protection Association, 1988, Guidelines on Limits of Exposure to Radiofrequency Electromagnetic Fields in the frequency Range From 100 KHz to 300 MHz, Health Physics, 54(1), 115-123.
2. Swarup G., Ingle N.A., Rajan K.K. and Sachdev R.N., 1990, Observed radiation exposures around a few typical industrial, scientific and medical radiofrequency sources, Proceedings of the National Symposium on DC and RF Powersources in Research and Industry, BARC, Bombay, Feb. 26-28, CP 43.1-CP 43.10 .
3. Brown-Woodman P.D.C., Hadley J.A., Richardson L., Bright D. and Porter D., 1989, Evaluation of reproductive function of female rats exposed to radiofrequency fields (27.12 MHz) near a shortwave diathermy device, Health Physics, 56(4), 521-525.
4. International Labour Office, Geneva, 1986, Protection of workers against radiofrequency and microwave radiation, a technical review, OSH 57,18-19, Geneva.
5. Monig C.A. and Koirtophann S.R., 1985, Modifications of a separated impedance match/torch assembly for inductively coupled plasmas, Applied Spectroscopy, 39,(5), 884-885.

Acknowledgement

Authors appreciate the interest shown by Dr.D.V.Gopinath, and Shri P.Gangadharan in the work reported.

Table 1. Observed electric field strength around a few medical, scientific and industrial sources of radiofrequency and microwave radiation

MEDICAL

Source of rf radiation : Diathermy unit
 Operating frequency : 27.12 MHz
 Power of unit : 500 W

Part of body	No. of obs.	Average field strength (V/m)				
		Distance from applicator plate (cm)				
		10	15	20	25	30
Back	16	776	598	238	194	
Neck	14	739	434	260	238	
shoulder	16	658	442	-	-	
knee	19	598	455	307	434	168

SCIENTIFIC

Source of rf radiation	operating frequency (MHz)	power of unit (kW)	Dist. from source (cm)	field strength (V/m)	remarks
ICP Units	27.12	2	5	19	Improperly terminated cable
			5	307	
Crystal growing furnace	0.45	10	20	868	Distances are from the bend position of the feeder line between osc. and furnace
			60	238	
			90	194	
			180	87	
Crystal growing furnace	0.38	25	5	751	Distances are from the feeder line near the furnace
			20	238	
			40	162	
Crystal growing furnace	0.38	25	30	672	Above the feeder line
			60	238	
			120	27	
Crystal growing furnace	0.38	25	5	823	Readings taken at the height of feeder line
			50	162	
			100	31	
			150	19	

(Table 1. Continued)

Source of rf radiation	operating frequency (MHz)	power of unit (kW)	Dist. from source (cm)	field strength (V/m)	remarks
Plastic sealing unit	30.00	1	5 10	162 90	Distances are from the electrodes
	30.00	1	10	>868	below RF cable to electrode
INDUSTRIAL					
Broadcast transmitters	11.83	100	1100	306	Distances are from the antenna
			6700	123	
			45000	72	
T.V. transmitters	62-67	10	40000	negligible	Antenna height 330 meters
Radar units	2-6 (GHz)	2 (Av)	10000	negligible	Pulsed beam, 1.6 MW peak power

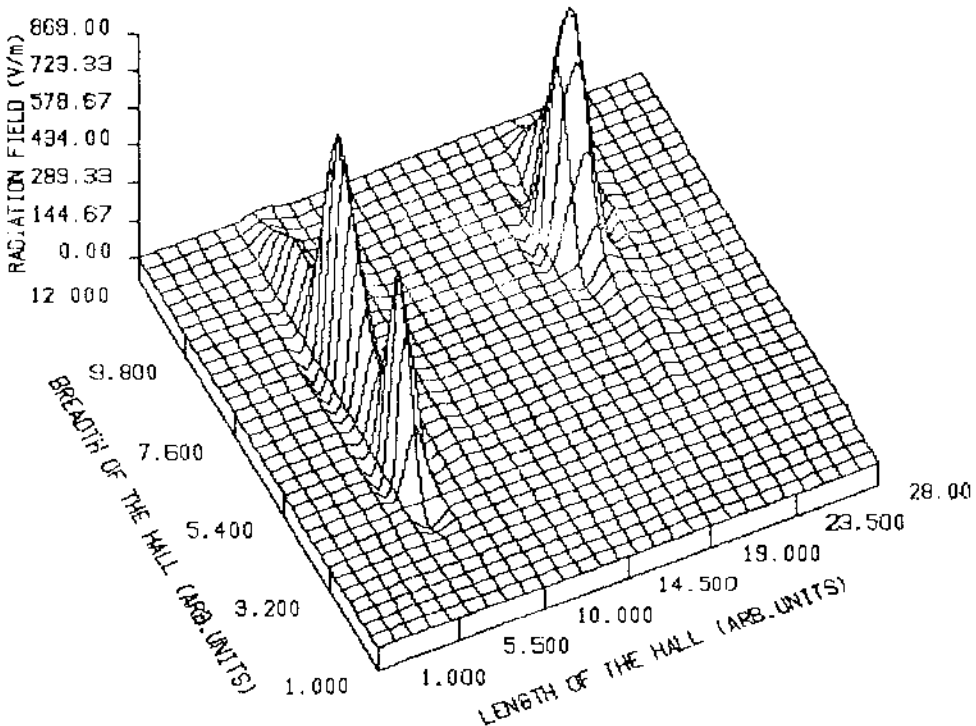

FIG. 1. RADIO FREQUENCY FIELD AROUND TWO CRYSTAL GROWING FURNACES HAVING 10 AND 25 kW POWER. ARBITRARY UNIT IS 0.5m.

A STUDY ON THE RELATIONSHIP BETWEEN INCOMING SOLAR UV RADIATION AND CLOUD COVER

V.J. Daoo

Health Physics Division
Bhabha Atomic Research Centre
Bombay-400085 (INDIA)

ABSTRACT

In this study an empirical relationship between the incoming solar UV radiation and concurrently measured cloud cover at Bombay ($19^{\circ}01'N$, $72^{\circ}55'E$), based on data pertaining to two year (1986-1987) period is established. It is compared with a similar relationship used elsewhere and found to differ in its form as well as in the regression coefficients. Possible reasons for this discrepancy are discussed. Conditions under which the two relationships agree are also examined.

INTRODUCTION

Observed data on solar UV radiation reaching the earth's surface are sparse and particularly so in tropics. In tropical region, recent studies by Chacko et al. (1983), Ilyas (1987) and Daoo et al. (1991) deal with such observations. In the absence of direct measurements, the solar UV radiation is generally estimated from its extra-terrestrial value and assuming certain average atmospheric conditions. It has been established that the UV radiation is significantly attenuated by cloud cover and the atmospheric ozone content before reaching the surface. Among these, variation in ozone content is known to be somewhat regular but not so the cloud cover variation. Hence estimates are generally made for clear sky conditions and effect of cloud cover is accounted for by using an empirical relationship between clear sky UV radiation and cloud cover observations. In this study one such attempt is described. Based on measured data on UV radiation during 1986-87 and concurrently observed cloud data at Bombay ($19^{\circ}01'N$, $72^{\circ}55'E$) an empirical relationship is established. This can be used to predict UV radiation if cloud data is available and clear sky radiation is known. Such relationship is particularly useful because cloud cover data are routinely available at National Weather Service stations in the country and can be conveniently used to predict incoming UV radiation under actual conditions.

MEASUREMENT AND SITE DETAILS

The measuring instrument was an Eppley UV radiometer (model TOVR) having a spectral response over the region 295-390 nm wavelengths. Measurement accuracy is within 5%. Data on cloud cover were obtained from weather reports routinely published by India Meteorological Department. The measurement site was within the campus of Bhabha Atomic Research Centre at

Bombay. The site is located in a region subject to industrial air pollution. Further the site experiences regular monsoon rains during June to September. During this period the sky is generally overcast with cumulus types of clouds. Even during non-monsoon periods the sky is rarely clear except for few occasions during winter months.

RESULTS AND DISCUSSION

Plot of ratio of monthly mean daily total of UV radiation (UV) to mean daily total under clear sky conditions (UV_0) and concurrent daytime average cloud observations in fractions of cloud cover (n) is shown in Fig 1. Average daytime cloud cover is obtained from the visual observations made after every three hours. Clear sky UV radiation is obtained from the computed clear sky global solar radiation for Bombay (Mani and Kangarajan, 1982) and using observed ratio of the UV radiation to the global solar radiation, during clear weather (Dado et al., 1991). Thus UV_0 represents the radiation received at the earth surface under cloudfree atmosphere for average atmospheric conditions with respect to other relevant constituents like ozone and dust content.

Visual inspection of the scatter plot suggests a non-linear relationship. Regression analysis of the data set gives following relationship :

$$UV/UV_0 = 0.80 + 0.45 n - 0.64 n^2 \quad (1)$$

with correlation coefficient (r) = 0.785

The only other equivalent relationship widely quoted in literature (Johnson et al., 1976; Ilyas, 1987), after converting it as per our notations is -

$$UV/UV_0 = (1 - 0.56 n) \quad (2)$$

Comparison of Eq (1) and (2) reveals that -

(1) Eq (1) is quadratic while Eq (2) is linear. For higher cloud cover amount ($n > 0.3$), Eq (1) also tends to show a monotonic decrease as expected from Eq (2). The quadratic relationship shows a major departure from the linear form for low cloud cover amounts. Low cloud cover amounts are generally associated with broken or passing clouds (usually of cirrus type in the present case). These type of clouds lead to significantly increased diffuse radiation compared to that under higher cloud cover conditions. As a result the incoming UV radiation initially (when the cloud cover is less) does not decrease as expected but shows a slight increase and afterwards (for higher cloud cover) it decreases monotonically. Higher cloud cover conditions are usually associated with uniform and continuous sheet type of cloud (generally of cumulus type in the present case) obstructing the sun directly and hence the monotonic decrease. Thus the quadratic expression given here could give more realistic estimates under low cloud cover conditions.

(2) Intercept of Eq (1) is 0.80 and not unity like Eq (2). Relatively larger atmospheric dust content in the region can be one of the responsible factors in determining this.

(3) In low cloud cover range ($n < 0.3$), Eq (1) when compared with Eq (2), underestimates the ratio UV/UV_0 (upto a maximum of about 25 %) while in the higher cloud cover range it generally overestimates the ratio (upto a maximum of about 12 %). Hence while using any such relationship for estimating the incoming solar UV radiation levels, consideration must be given to the higher and lower ranges of cloud cover amounts. Otherwise the results can be misleading. This is particularly true for tropical regions where low cloud cover conditions occur with significant frequency.

CONCLUSIONS

The relationship established in this study is quadratic in form in contrast to linear relationship used in earlier studies. The difference has been attributed to the type and nature of cloud cover and dust content prevailing in the atmosphere. The relationship used in the earlier studies is generally suited for high cloud cover conditions (cloud cover > 0.3) whereas the present relationship is applicable to whole range of cloud cover.

REFERENCES

1. Chacko, O., Rahalkar, C.G. and Desikan, V., 1983, Ultraviolet radiation at Pune, Mausam, 34, 4, pp. 425-430.
2. Ilyas, M., 1987, Effect of cloudiness on solar ultraviolet radiation reaching the surface, Atmos. Environ., 21, pp. 1483-1484.
3. Daoo, V.J., Faby Sunny and Shirvaikar, V.V., 1991, Solar UV radiation measurements at Bombay, Ind. J. Pure & Appl. Phys., 29, pp. 71-72.
4. Mani, A. and Rangarajan, S., 1982, Solar radiation over India, Allied Pub. Pvt. Ltd., New Delhi, India.
5. Johnson, F.S., Mo, T. and Green E.S., 1976, Average latitudinal variation in ultraviolet radiation at the earth's surface, Photochem. Photobiol., 23, pp. 179-188.

ACKNOWLEDGEMENTS

Author is thankful to Mr. V. Sitaraman, Dr. V.N. Bapat and Mrs. Faby Sunny for useful discussions on the subject. Thanks are also due to Mr. T.M. Krishnamoorthy Head, Site evaluation section and Dr. K.C. Pillai, Head, Health Physics Division, for providing all the facilities for carrying out this study.

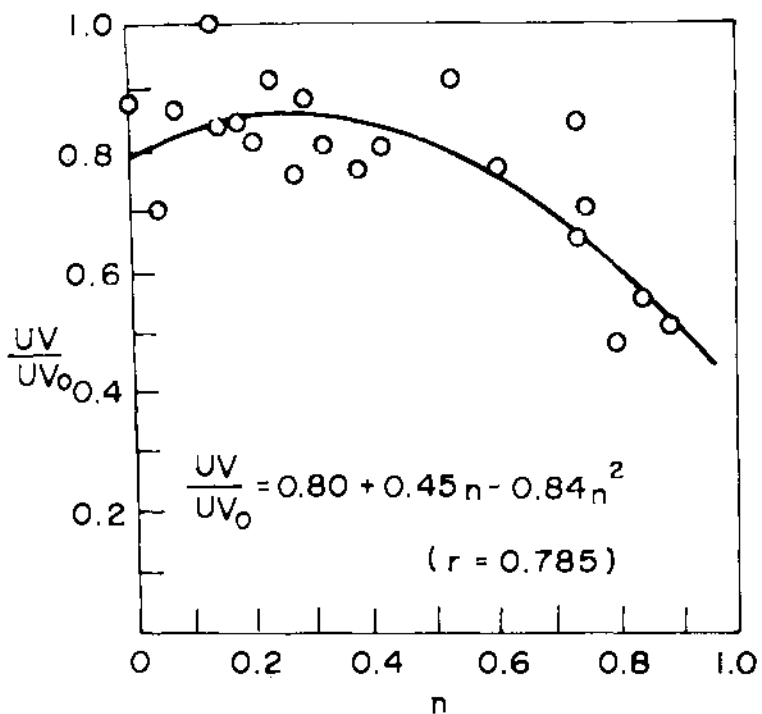

FIG. 1. RELATIONSHIP BETWEEN RATIO OF ACTUAL TO CLEAR SKY SOLAR UV RADIATION (UV/UV_0) AND CLOUD COVER IN FRACTION (n) (BOMBAY 1986-87)

PERSONAL DOSIMETRY OF SOLAR UVB USING POLYSULPHONE FILM

HP Gies, CR Roy, E Herlihy* and J Rivers#

Australian Radiation Laboratory
Lower Plenty Road, Yallambie, Victoria, 3085

* Menzies Centre for Population Health Research
43 Collins St, Hobart, 7000

Sydney Melanoma Unit, Royal Prince Alfred Hospital
Camperdown, NSW, 2050

ABSTRACT

Polysulphone film badges have been used to quantify the solar UVR exposure received by different subjects and these measured results are compared to those calculated from personal diaries and measured ambient solar UVB. In general, when UVR exposure activities took place under close supervision, good correlations were obtained between the polysulphone badges and the ambient/diaries approach. UVR exposures for indoor workers and a number of outdoor activities are presented.

INTRODUCTION

Recent evidence confirming the presence of global ozone depletion and of Antarctic ozone 'holes' has increased the concern over possible adverse human health effects as a result of increased levels of solar UVR. The scarcity of accurate long-term ambient UVR measurements and the lack of knowledge of personal solar UVR exposure has also become apparent.

Previous measurements of the anatomical distribution of solar UVR using polysulphone (PS) film as a dosimeter have been made with both mannikins and headforms as well as volunteers in a variety of outdoor activities^{1,2}. Personal histories of UVR exposures have been determined from retrospective questionnaires and the results used in epidemiological studies into factors affecting skin cancer incidence. Careful design of the questionnaire or diary of UVR exposure is crucial, as is the choice of sites at which the badges are worn.

EXPERIMENTAL MEASUREMENTS

The ARL radiometer/datalogger network³, which collects data continuously during daylight hours, provided ambient UVB levels for both the Sydney and Hobart studies. The dose response of PS film to solar UVR, which relates the change of absorbance (dA) to the erythemally effective dose (EED) in $J.m^{-2}$, can be determined from simultaneous exposure of the PS film and measurement of the incident solar UVR spectral power distributions^{4,5}. As the change in absorbance dA increases (ie for larger UVR exposures) the estimation of EED becomes less accurate. Any study to monitor UVR should try to limit the UVR dose to PS badges to the linear or near linear region of the dose response curve (dA less than 0.5).

Two studies using polysulphone dosimeters and volunteers were undertaken. The month-long Sydney study, in February and early March 1990 was undertaken in collaboration with the Sydney Melanoma Unit. The group of 40 indoor workers each wore a single PS badge attached at the shoulder. A new badge was used each day, some subjects recording the time periods spent outdoors on a time line in a diary at the end of each day, while others were asked to record the information only at the end of the study. In this way it was hoped to detect whether there was any variation in recall between the two groups of subjects. Following initial discussions at the beginning of the study, the subjects were given their PS badges and no further direct supervision took place.

The Hobart study, in collaboration with the Menzies Centre, took place primarily on two days in February 1991, with two small groups participating in a trial the previous day. Subjects each wore eight PS badges at different anatomical sites, while participating in one of the following activities, pool swimming (SM), sailing (SL), bushwalking (BW), gardening (GN), playing tennis (TN) or golf (GF). The subjects then filled in a comprehensive questionnaire covering the duration of solar UVR exposure, type of clothing or sunscreen worn, ground surface cover, and many other details. As well as determining the anatomical distributions of UVR, the calculated ambient/diary UVB exposure could be compared with the PS badge measurement to determine whether the subjects' diaries gave an accurate reflection of their UVR exposures.

RESULTS

As the Sydney study volunteers were indoor workers, the measured PS badge EEDs were generally low, the mean value for the group of subjects was $82 \pm 51 \text{ J.m}^{-2}$. In most cases exposure to solar UVR was in the morning and evenings on the way to and from work, with some contribution to the UVB exposure during lunch hour.

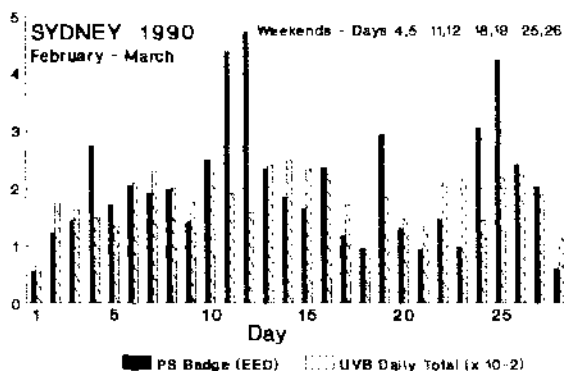

Figure 1. A comparison of the total measured PS badge exposures EED (J.m^{-2}) for the group of subjects for each day with the daily total UVB (radiometer counts).

Correlation between the EED from the PS badges and the calculated ambient/diary exposure for the Sydney study was poor. The variation between individuals was large. The diary provided no opportunity to indicate the quality of the UVR exposure, which is affected by shade and buildings in the immediate vicinity. If the subjects were analysed as a group, a pattern did emerge. Figure 1 shows the sum of the exposures in $J.m^{-2}$ for the entire group of subjects for each day, while also showing the daily total of ambient UVB (to a different scale). The weekend days stand out as days of high UVR exposures, the mean week day exposure being $65 \pm 26 J.m^{-2}$ while that for the weekend days was twice this at $123 \pm 54 J.m^{-2}$. The maximum measured daily total EED for any subject was 2060 $J.m^{-2}$, which occurred on a weekend. Monthly UVR exposure totals for each subject ranged from 500 to 6865 $J.m^{-2}$ (mean of $2294 \pm 1430 J.m^{-2}$).

Supervision of subjects and PS badge placement was more tightly controlled in the Hobart study. Figure 2 shows a comparison of the PS badge exposures EED in $J.m^{-2}$ with the UVB/diary calculations. The activities in the Hobart study can be considered to fall into two broad categories, the first where the subjects would have spent a fair proportion of their time out of the direct sun (in amongst trees etc for the BW, GF and GN), the second where the activities took place predominately in the open. Comparison of the PS badge readings with the UVB/diary calculations for the TN, SL and SM subjects in Figure 2(A) shows a series of points scattered about the expected straight line (ie good correlation). However, the comparison for the BW, GF, and GN in Figure 2(B) shows considerable scatter, with the points all in the region of the graph where the PS badge readings are less than the corresponding UVB/diary entries. These lower measured EEDs and the scatter in the results (BW,GF,GN) are almost certainly due to subjects spending different amounts of time in the shade. The effective exposure rates I in $W.m^{-2}$ (Table 1) are generally less than for the other activities (TN, SL, SM).

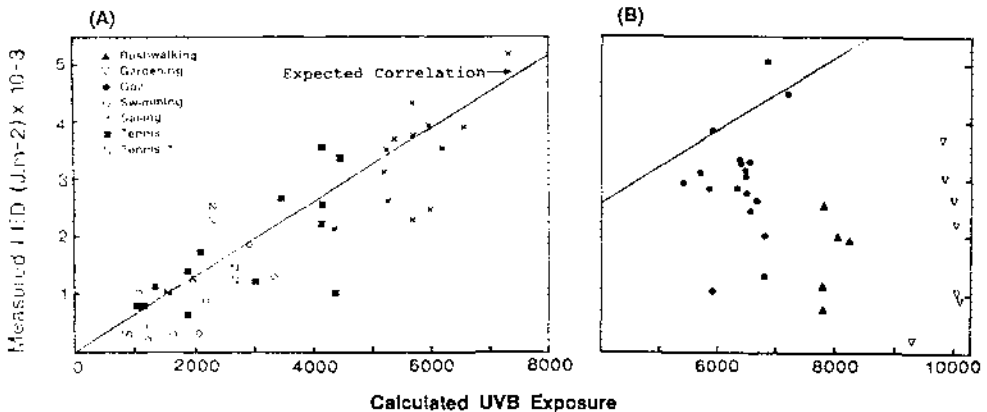

Figure 2. A comparison of the measured PS surface badge exposures EED ($J.m^{-2}$) for the different activities with the UVB exposures calculated from the diary entries and the measurement of ambient UVB (radiometer counts).

TABLE 1

The variation of UVR exposure with anatomical site as a fraction of ambient for different outdoor activities for the Hobart study (* denotes Day 1).

ACTIVITY Tennis* Tennis Sailing Swimming Walking Golf Gardening*

SITE	Tennis*	Tennis	Sailing	Swimming	Walking	Golf	Gardening*
Cheek	0.20	0.36	0.25	0.43	0.08	0.21	0.24
Hand	0.43	0.54	0.54	0.94	0.30	0.51	0.19
Shoulder	0.52	0.79	0.70	1.39	0.22	0.76	0.30
Back	0.40	0.57	0.57	0.98	0.39	0.66	0.31
Chest	0.32	0.41	0.28	0.61	0.17	0.36	0.14
Thigh	0.26	0.47	0.44	0.72	0.20	0.42	0.14
Calf	0.40	0.51	0.25	0.62	0.19	0.41	0.16
Surface	1.00	1.00	1.00	1.00	0.39	0.74	0.30
EED(J.m ⁻²)	814	928	1712	289	834	1355	766
I#(mW.m ⁻²)	158	122	125	77	47	91	31

I is the effective irradiance calculated from the PS badges

The Hobart UVR exposures EEDs (Table 1) are higher than the average daily EED for the Sydney study, although they are comparable with many of the weekend exposures. Table 1 shows that the shoulder badges have the highest exposures, the reason this site was used for the Sydney study. The UVB exposure rates given by I in Table 1 show that activities (TN, SL, SM) which occur in the open have the highest UVB exposure, although (GF) can also have quite large UVB exposure rates.

CONCLUSIONS

Preliminary analysis of both studies indicate that good correlation between measured and calculated UVR exposures can be achieved if sufficient information is recorded in the diaries and if exposures occur under close supervision. In Australia the highest exposures to solar UVR (apart from outdoor workers) are due to outdoor recreational activities and any effort to reduce the general population's UVR exposures needs to concentrate on these.

REFERENCES

1. Diffey, BL, Kerwin M and Davis A, 1977. Br J Dermatol, 97, pp 407-410.
2. Holman, CDJ, Gibson, IM, Stephenson, M and Armstrong, BK, 1983. Clin Exp Dermatol, 8, pp 269-277.
3. Roy, C, Gies, HP and Elliott, G, 1989. Transactions of the Menzies Foundation, Vol.15, pp 71-76.
4. Diffey, BL, 1987. Photochem Photobiol, 46, pp 55-60.
5. Gies, P, Roy, C and Elliott, G, 1987. IRPA Congress Proceedings, Vol.I, pp 341-344, 1987.

UV radiation: sources, effects and risks of human and environmental exposure

G.J. Eggink, H. Slaper
Laboratory for Radiation Research,
National Institute of Public Health and Environmental Protection
P.O.Box 1, 3720 BA BILTHOVEN, The Netherlands

ABSTRACT

This paper summarizes the principal results of a review study on UV-exposure and UV related risks in the Netherlands. Both the present state of affairs and future developments are discussed, the latter partly based on model calculations.

The sun is the main UV source to which the whole population is exposed. Solar exposure is estimated to amount to at least 90% of the annual UV burden for the Dutch population. For certain groups in the population man made sources are estimated to contribute considerably to the yearly UV dose. Ozone depletion as a result of human activities, growing use of tungsten halogen lamps and increasing application of UV-sources in industry and medicine all tend to increase UV exposure.

UV exposure can lead to a wide variety of health effects, among which the induction of skin cancer, skin aging, cataract formation and suppression of immune responses. Risk estimates of these health effects are available for skin cancer and to a lesser extend for cataracts. The estimated UV related skin cancer incidence rate in the Netherlands is 10^{-3} per year (15 000 cases), and the associated mortality rate amounts to $6-25 \cdot 10^{-6}$ per year (90-400 deaths). The ozone depletion presently observed over the past decade (5% in the Netherlands), is expected to lead to an increased annual mortality rate due to skin cancer of $1,3 \cdot 10^{-6}$ per year.

Environmental exposure can influence plant physiology and lead to a decrease of biomass in aquatic as well as terrestrial ecosystems. This may result in adverse effects on the foodweb and biodiversity of ecosystems. Quantitative risk estimates for these effects are very uncertain or lacking.

INTRODUCTION

UV-exposure of man and the environment is caused by emissions from a number of sources. The UV-burden for man as well as for ecosystems is expected to increase due to:

- the depletion of the ozone layer (the main UV absorbing layer in the earth's atmosphere)
- the increasing use of UV-emitting light sources (e.g. tungsten halogen lamps)
- the use of tanning equipment
- the use of UV sources in industry and laboratories (lasers, welding, lamps for paintdrying, copiers, etc.)
- the use of UV-sources in medical therapies (PUVA, UVB-therapy, lasers)

Based on the recent knowledge of exposure and effects, an estimation is made of the related risks of (over)exposure.

Based on the 'source-distribution-exposure-effect-risk chain' this UV issue will be presented.

SOURCES, DISTRIBUTION AND EXPOSURE

The sun is the main and only natural UV source on earth. The spectral distribution peaks in the visible part of the spectrum with a relative large fraction in the UV. Due to the absorbing and scattering properties of the atmospheric layers (esp. the ozone layer) the radiation reaching the earth surface contains less UV.

The effectiveness of UV radiation is strongly dependent upon the wavelength. The MED is used as a unit for effective UV-doses and corresponds to a UV-dose which is just sufficient to elicit erythema (in unadapted white skin). One MED is equivalent to a dose of 200 J/m^2 of monochromatic 297 nm radiation.

In the Netherlands the total amount of solar (erythema-effective) UV radiation is estimated to be 2200 MED/a (Schothorst, 1987; Slaper, 1987). Over 75% is available in the period May-August; less than 7.5% from November-February. Based on measurements with personal dosimeters indoor workers are estimated to be exposed to about 70 MED/a and outdoorworkers receive about 150 MED/a (Slaper, 1987). The dose acquired during holidays must be added to this and is estimated to be 2-50 MED for a three weeks period in the Netherlands and 60-150 MED for three weeks in the Mediterranean (Health Council, 1986).

Based on recent measurements by NASA satellites the ozone layer decreased with an average of 5% in the last 10 years in North West Europe (Stolarski et al, 1991). Model calculations of the UV-transfer in the atmosphere indicate that this reduction leads to an increase in erythema-effective UV on the earth surface of about 6.5%. This in turn corresponds to an additional 6.5 MED/a for the average exposed person in the Netherlands and an

additional 13 MED/a for the group with highest sun exposure (5% of population).

Artificial UV-sources are found in various applications: regular lighting systems, tanning equipment, medical phototherapies, industrial lightsources, lasers etc. In the indoor environment exposure can be divided in intentional and unintentional exposure. Intentional exposure takes place during tanning and medical UV therapies.

Depending on the characteristics of the lightsources (e.g. temperature of tungsten lamps, quality of the glass envelope, pressure and gas used in gas discharge lamps etc.) the UV emission can vary by several orders of magnitude.

Assuming an exposure time of 500 h/a (= 1.5 h/d) a potential exposure of 10-500 MED/a for tungsten halogen lights and about 2 MED/a for fluorescent lamps is estimated (McKinlay et al, 1989). Personal dosimetry is lacking. It appears that tungsten halogen lamps are the most important UV emitting artificial lightsources for the general public.

The use of special UV emitting fluorescent lamps for tanning is widely spread in the Netherlands. About 7% of the population (= 1 million) uses tanning equipment. The average yearly dose received as a result of the use of these artificial sources is estimated to be 74 MED/a (Berghahn & Bruggers, 1986).

Since 1900 ultraviolet radiation is used in medical therapies, for treating tuberculosis, rachitis, and later on for treating several skin diseases. Nowadays UV is mainly used in treating psoriasis (ca 200 000 patients in the Netherlands). Two types of therapy are common: PUVA and UVB-therapy. In PUVA the skin is sensitized by means of psoralens and treated with UVA ("black-light"). In UVB-therapy the skin is directly exposed to UVB. The average yearly dose is 250 MED/a, but doses of more than 500 MED/a are not unusual. For PUVA-therapy the UV dose depends greatly on the amount and type of psoralens. An average value can not be given. Figure 1 gives the estimated yearly doses for the general public and for some selected groups of the population. In this figure outdoors workers are farmers, fishermen, roadworkers etc. Halogenlamp users are assumed to be exposed to bare halogen lamps for 500 h/a at a distance of 30 cm.

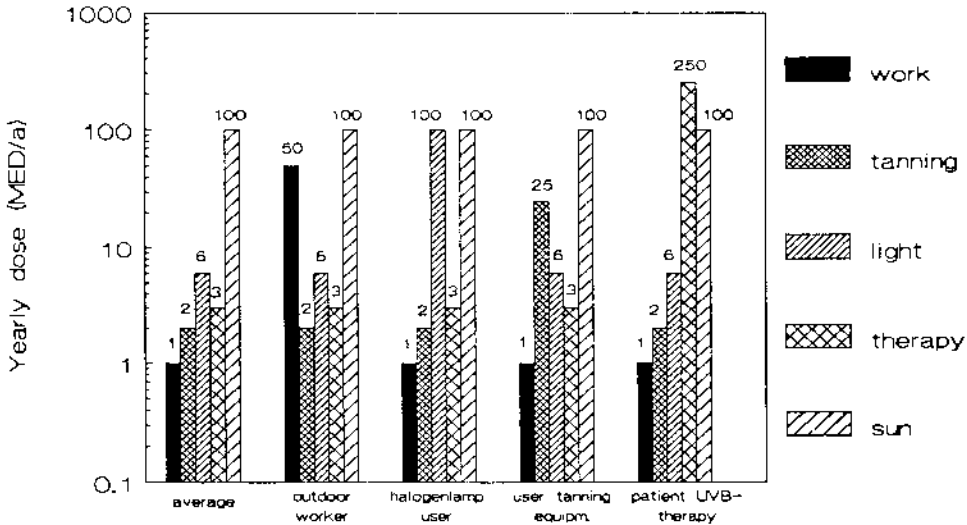

Figure 1. Estimated yearly effective UV dose for the general public and some selected groups in the Netherlands.

EFFECTS AND RISKS

UV exposure can lead to several deleterious effects in man, some shortly after acute exposure (sunburn, snowblindness) and some after prolonged exposure (skin cancer, skin aging, damage to the immune system and cataract formation).

For skin carcinoma (basal cell carcinoma and squamous cell carcinoma) UV exposure is assumed to be the main cause. For melanoma and cataract it is believed that UV contributes to the incidences although the extend is uncertain. The incidence and mortality rate for skincarcinoma, melanoma and cataract operations in the Netherlands is given in figure 2a. Figure 2b provides estimates of the additional effects of a 1% increase in effective exposure (1 MED additional for average exposed group).

A 1% increase of the effective UV exposure is expected to lead to an increase in cataract incidence of 0.5%, corresponding to an increased incidence rate of 10^{-5} per year in the Netherlands. This implies an additional 100-150 cataract operations per year in the Netherlands.

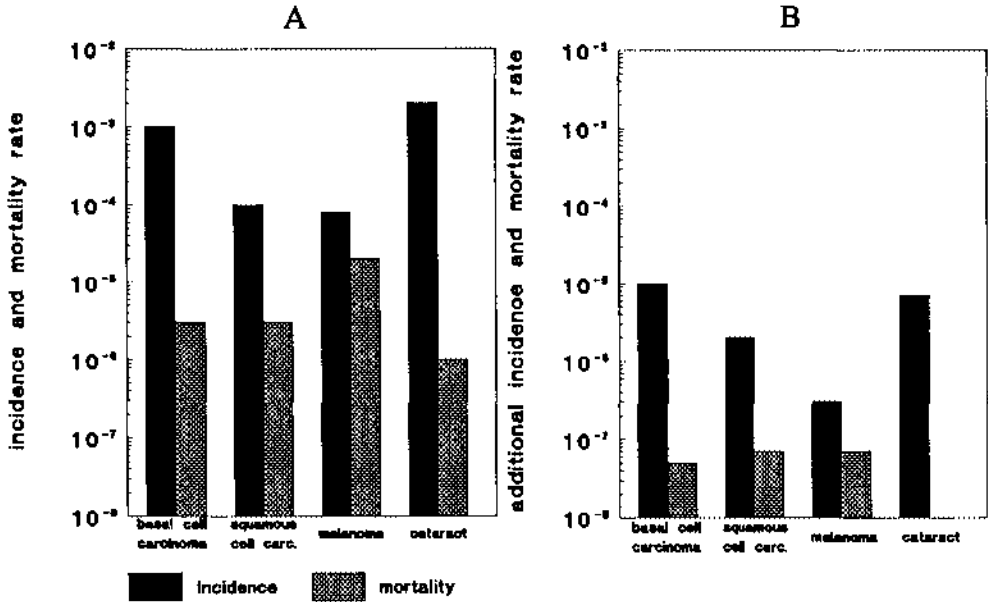

Figure 2. A. Incidence and mortality rate of carcinoma, melanoma and cataract (operations).
B. Additional incidence and mortality rate caused by an additional 1% effective UV.

Death rates due to skin cancer in the Netherlands are: 80-90 deaths per year due to skin carcinoma, 300 deaths per year due to melanoma. The estimated yearly mortality rate in the Netherlands associated with average UV exposure is $6.25 \cdot 10^{-6}$ per year. For 'highly-exposed' persons (200 MED/a) this is $25.55 \cdot 10^{-6}$. Based on models, the additional mortality rate for the 'average-exposed' group is calculated to be $2 \cdot 10^{-7}$ per MED. For the 'high-exposed' group this is estimated to be $4 \cdot 10^{-7}$. For persons with an extra sensitive skin the risks are $4 \cdot 10^{-7}$ and $7 \cdot 10^{-7}$ per MED respectively. Table 1 gives an overview of the estimated risks and mortality rates for various exposure situations.

Evidence has been gathered in experiments with animals and humans that UV exposure of the skin causes damage to the immune system. An assessment of the risks can not yet be made, due to a lack of information about the mechanism, the dose-reponse relation and the action spectra.

In terrestrial plants UV exposure can influence several processes that have a negative effect on the growth and development of plants, like smaller leaf size, less flowering, and a lower photosynthetic activity. These effects can be reinforced by certain deficiencies and waterstress (UNEP, 1989). Although this is very species-specific (even great intraspecific (cultivar) differences have been observed) many of the observed effects lead to a decrease of biomass by influencing the primary production. Further study is needed to get more information on the mechanisms of UVB-effects and the possible effects of ozone depletion on food plants.

Research indicates that also phytoplankton and zooplankton in aquatic ecosystems can be affected. This includes orientation, motility, photosynthesis and enzymatic reactions and the survival of small marine organisms during their first stadia of life (fish eggs and -young, shrimp larvae and crab larvae). These changes can lead to disturbance of stable ecosystems, and can have negative effects on the foodweb, the biodiversity of ecosystems, and finally on the human food supply. Based on the assumption of a 5% decrease in primary production (estimated for a 16% ozone depletion) Häder calculated that fish yield would reduce by approximately 6-9% (a 7% reduction in fish yield, if it is on a global basis, would then represent a loss of about 6 million tons of fish per year) (Häder et al, 1989). However, uncertainties regarding the magnitude of these effects remain large, because of problems of extrapolating laboratory findings to the open sea and the nearly absence of data on long-term effects and ecosystem responses.

Further research on the ecosystem effects is necessary to get a proper view of their possible ecological impact.

Sources	exposure	estimated group size	effective dose (MED/y)	mortality rate	
<u>outdoor environment</u>					
sun	normal	15 · 10 ⁶ (100%)	100	6-25 · 10 ⁻⁶	
	high	7 · 10 ⁵ (5%)	200	25-55 · 10 ⁻⁶	
	high, sensitive skin	2 · 10 ⁵ (1.3%)	200	30-150 · 10 ⁻⁶	
ozone depletion ¹⁾	normal	15 · 10 ⁶ (100%)	7 (?)	1,3 · 10 ⁻⁶ ²⁾	
	high	7 · 10 ⁵ (5%)	13 (?)	5 · 10 ⁻⁶ ²⁾	
	high, sensitive skin	2 · 10 ⁵ (1.3%)	13 (?)	9 · 10 ⁻⁶ ²⁾	
<u>indoor environment</u>					
tungsten halogen lamps					
- 500 hours desk-lamp					
distance 30 cm	normal	1 · 10 ⁵ (0.7%)	(?)	100 (?)	20 · 10 ⁻⁶ ²⁾
fluorescent lamps					
- 500 hours					
distance 100 cm	normal	1 · 10 ⁶ (7%)	(?)	2 (?)	0,4 · 10 ⁻⁶ ²⁾
tanning equipment	normal	1 · 10 ⁶ (7%)	(?)	25 (?)	5 · 10 ⁻⁶ ²⁾
<u>medical therapy</u>					
UVB-therapy (psoriasis)	normal	1 · 10 ⁵ (0.7%)	(?)	250 (?)	50 · 10 ⁻⁶ ²⁾
¹⁾	additional UV exposure caused by measured ozone depletion (5%)				
²⁾	additional risk caused by the indicated source				
(?)	estimated exposure				
(??)	groupsize not known (preliminary estimate)				

Table 1. Estimated effective doses and mortality rates for different groups of the Dutch population due to different UV sources. The estimated group size is based on a total population of 15 million persons.

REFERENCES

- Berghahn, A.J.; Bruggers, J.H.A. *Individueel gebruik van UV-toestellen en eventuele ongewenste gevolgen in Nederland. Rapport Stralenescherping 18*, Den Haag: Ministerie van Volkshuisvesting, Ruimtelijke Ordening en Milieubeheer, 1986.
- Häder, D.P.; Worrest, R.C.; Kumar, H.D. *Aquatic ecosystems*. In: UNEP, Environmental Effects Panel Report. Nairobi: UNEP, 1989.
- Health Council of the Netherlands. *UV radiation. Human exposure to ultraviolet radiation. A report of a committee of the Health Council of the Netherlands. report nr 09/1986*. The Hague: Health Council, 1986.
- McKinlay A.F.; Whillock, M.J.; Meulemans, C.C.E. *Ultraviolet radiation and blue-light emissions from spotlight incorporating tungsten halogen lamps. NRPB-R228*. Chilton: National Radiological Protection Board, 1989.
- Schothorst, A.; Slaper, H.; Telgt, D.; Alhadi, B.; Suurmond, D. *Amounts of ultraviolet B (UVB) received from sunlight or artificial UV sources by various population groups in the Netherlands*. In: Passchier, W.F.; Bosnjakovic, B.F.M. (eds). *Human exposure to ultraviolet radiation. Risks and regulations*. Amsterdam: Excerpta Medica, 1987.
- Slaper, H. *Skin cancer and UV exposure: investigations on the estimation of risks*. Ph D Thesis. Utrecht: University of Utrecht, 1987.
- Slaper, H., Eggink G.J. *Exposure to ultraviolet radiation. report nr 249104002.*, in Dutch. RIVM, Bilthoven 1991
- Stolarski, R.S.; Bloomfield, P.; McPeters R.D. *Total ozone trends deduced from nimbus 7 TOMS data. Geophys Res Lett 1991; 18(6): 1015-8*.
- UNEP. *United Nations Environment programme. Environmental Effects Panel Report*, november 1989.

LES EFFETS DES CHAMPS ÉLECTROMAGNÉTIQUES DE 50/60 Hz:
BILAN ET PERSPECTIVES DE SANTÉ PUBLIQUE POUR LE QUÉBEC

P. LEVALLOIS, P. LAJOIE, D. GAUVIN.
Département de Santé communautaire
Centre Hospitalier de l'Université Laval,
Ste-Foy, Québec.

HEALTH EFFECTS OF EXTREMELY LOW FREQUENCY (ELF) FIELDS:
A PUBLIC HEALTH PERSPECTIVE FROM QUÉBEC:

This communication summarizes the report presented to the Quebec government by an expert-committee. The main health effects of ELF fields are reviewed and a discussion of the public health impact for Quebec is presented. Recommendations include the need of further research as well as a public information program and major efforts to improve risk assessment.

INTRODUCTION

En 1987, le gouvernement du Québec autorisa la construction d'une ligne à haute tension sur son territoire à la condition qu'un comité interministériel, coordonné par le ministère de la Santé et des Services sociaux du Québec, assure un suivi des études sur les effets des lignes à haute tension sur la santé. La présente communication résume l'état de situation sur les connaissances scientifiques qui a été déposé et accepté par ce comité¹.

RÉSULTATS

Plusieurs effets potentiels chez l'humain, associés à l'exposition chronique aux champs électromagnétiques de très basses fréquences ont été inventoriés. Le risque de cancer est le mieux documenté. D'une part, plusieurs chercheurs ont observé des associations entre l'exposition à ces champs (mesurée ou estimée) et l'incidence de certains cancers chez l'enfant: leucémies, tumeurs du système nerveux, lymphomes. D'autre part, plusieurs études réalisées en milieu de travail ont montré, de façon répétée, une association entre l'inci-

dence de leucémies et de tumeurs du cerveau et l'exercice d'une profession dans laquelle il y a exposition aux champs électromagnétiques de basses fréquences: électriciens, monteurs de ligne, soudeurs, etc.. Bien que plusieurs lacunes empêchent de porter un jugement définitif sur le risque de cancer (principalement à cause des difficultés de mesure de l'exposition), on doit considérer ce risque comme possible. D'une part, les études les plus perfectionnées tendent à confirmer les résultats des premières études, d'autre part, la plausibilité biologique de telles associations s'est renforcée ces dernières années. Même si le risque relatif de cancer est probablement faible pour les personnes anormalement exposées (RR <2), le risque pour la santé publique peut être important. Ceci est dû à l'omniprésence des champs et au nombre important de personnes exposées à ces champs. Ainsi, si 20 % de la population à risque était exposée de façon anormale et si le RR était de 1,8, 14 % des cancers incidents pourraient être attribuables à cette exposition.

D'autres problèmes de santé ont été moins investigués. Il s'agit principalement des troubles de la reproduction (infertilité, avortements, malformations congénitales) et des troubles neuropsychiques (en particulier les états dépressifs). Il est cependant encore trop tôt pour porter un jugement sur la possibilité de tels effets. Cependant, à cause de leur plausibilité biologique, ils ne devraient pas être négligés dans les recherches futures.

CONCLUSION

Le Québec, particulièrement par l'intermédiaire de la société d'État Hydro-Québec, participe à l'effort mondial de recherches pour élucider l'impact potentiel des champs électromagnétiques sur la santé humaine. Il faut poursuivre ces efforts mais ne pas s'y limiter. Dès maintenant des mesures devraient être prises pour mieux connaître l'exposition des populations québécoises à ces champs. Il y a lieu aussi de mettre sur pied un programme d'information publique sur le sujet. Le Québec devra aussi participer activement à l'effort international visant à mieux évaluer et gérer un tel risque environnemental.

1. P. LEVALLOIS, P. LAJOIE, D. GAUVIN. Les effets des champs électromagnétiques de 50/60 Hz sur la santé: bilan et perspectives de santé publique pour le Québec. DSC du CHUL, Québec, janvier 1991, 231 p.

CHROMOSOMAL ABERRATION ANALYSES OF BYELORUSSIAN CHILDREN
EXPOSED TO CHERNOBYL FALLOUT

S. Salomaa, A. Koivistoinen, W. Paile, T. Rahola, and T. Rytömaa

Finnish Centre for Radiation and Nuclear Safety
P.O.Box 268, 00101 Helsinki, Finland.

ABSTRACT

The radiation exposure of 26 Byelorussian children visiting Finland in summer 1990 was estimated by chromosomal aberration analyses and whole body counting. For comparison, twelve children from southern Finland were studied similarly. In general, the children were healthy and blood pictures and thyroid function tests were within the normal range. In the whole body measurements, the only nuclides detected were cesium-137 and cesium-134. The cesium body contents of the Byelorussian children were low (mean 6.3 Bq/kg of ^{137}Cs and 0.4 Bq/kg of ^{134}Cs), similar to those of the Finnish children. However, the Byelorussian children had significantly higher frequencies of radiation-related chromosome-type aberrations in their lymphocytes than the Finnish children.

INTRODUCTION

After the Chernobyl accident, many controversial reports have appeared of the radiation exposure and the possible health impact of the population living in the most affected areas. Also in the field of biological dosimetry the data are either inadequate or puzzling. Without any actual figures published, local studies have been described where no differences in the chromosomal aberration frequencies have been observed between the subjects living in contaminated or control areas. On the other hand, scientific papers report unexpectedly high aberration frequencies after exposures to minimal radiation doses from cesium in Central Europe.

We have estimated the radiation exposure of 26 Byelorussian children visiting Finland in summer 1990, four years after the Chernobyl accident, by whole body counting and chromosomal aberration analyses, and compared the results to Finnish children of the same age. Also the health status of the visitors was investigated.

MATERIAL AND METHODS

There were 15 girls and 11 boys in the Byelorussian group and their mean age was 14 years. The children originated from the Minsk, Mogil'ov and Gomel areas. Of these, the Gomel area is the most polluted by Chernobyl fallout, and the Minsk area the least. The surface contamination of cesium-137 in the Gomel area typically ranges from 37 to more than 1480 kBq/m², in the Mogil'ov area from less than 37 to 555 kBq/m², and is less than 37 kBq/m² in the Minsk district. In the Gomel region, there are also minor areas contaminated by strontium-90 with surface activities from 37 to 111 kBq/m².

The health status of the children was clarified by interviews and clinical investigations. Information was obtained on

diagnoses given to the children in Byelorussia. In Finland, every child went through a physical examination made by a general practitioner, and a few were referred for a specialist consultation. All the children were investigated for complete blood picture including differential count of leukocytes; free thyroxine, and thyroid-stimulating hormone. Other tests were made if indicated.

The activity in the body was measured using two whole-body counters. The IRMA 1 whole-body counter, installed in an iron room, uses a multidetector scanning technique, with four NaI(Tl)-crystals. The scanning time is 30 minutes and the minimum detectable activity (MDA) for cesium-134 and cesium-137 is 30 Bq. The mobile IRMA 2 whole body counter has a measuring geometry of chair type and a high purity germanium detector with 27 percent efficiency. The measurement time is 1,000 seconds and the corresponding MDA for cesium-134 and cesium-137 about 50 Bq.

Routine 48-hour lymphocyte cultures were established and 200 cells from each subject were analysed for chromosomal aberrations. The chromosomal aberrations scored included both chromatid aberrations (breaks, gaps) and chromosome-type aberrations (breaks, gaps, dicentric, rings, translocations and inversions). The results of chromosome aberration analyses were tested by Fisher's exact probability test.

For the results of whole body measurements and chromosomal analyses, the Byelorussian children were compared to twelve children from the southern Finland, matched by age, sex, and X-ray examinations. The control children originated from an area where the surface activity of cesium-137 was less than 6 kBq/m².

RESULTS

Generally, the children were in good health, and no major health problems were noticed. A clear discrepancy was noticed between diagnoses given them in Byelorussia and the scarcity of findings during their stay in Finland. Diagnoses like gastritis, arthritis, and neurocirculatory dystonia were frequent but, as a rule, could not be confirmed. Six of the children were reported to have an enlarged thyroid, which is not surprising, as they come from an area in which goiter is endemic. Four of these cases could be confirmed at the time of the examination in Finland. All of the children were, however, clinically euthyroid. The thyroid function tests were all in the normal range. The blood pictures were all normal except two cases of eosinophilia and two cases of slight anemia of iron deficiency type.

The results of the whole body measurements are shown in Table 1. The only Chernobyl fallout nuclides found were cesium-137 and cesium-134, with mean activities of 6.3 Bq/kg and 0.4 Bq/kg, respectively, in the Byelorussian group. The children from the Mogil'ov and Gomel districts tended to have higher values than those from the Minsk district, as could be expected by the distribution of surface ground contamination. As a whole, however, the cesium body contents of the Byelorussian children were low, similar to those of the Finnish children living in much less contaminated areas.

The internal mean effective dose equivalent delivered in 1990 from radiocesium to Finnish children was less than 0.05 mSv. The total internal dose delivered to the Finnish children studied from

1986 to 1990 was about 0.2 mSv. The external dose equivalent during the same time period was higher and the total mean effective dose equivalent 1986-1990 was estimated at 0.6 mSv. For the Byelorussian children studied, no information on temporal behaviour of radiation doses after the Chernobyl accident was available.

Table 1 The whole body contents of Chernobyl fallout nuclides in the Byelorussian children and the controls

Region	No. of subj.	Cesium-137 Bq/kg, mean (range)	Cesium-134 Bq/kg, mean (range)
Minsk	10	4.0 (3.2-5.2)	0.3 (0-0.8)
Mogil'ov	15	7.6 (3.1-14)	0.4 (0-2.0)
Gomel	1	9.2	1.5
Total	26	6.3 (3.1-14)	0.4 (0-2.0)
Control (Finland)	12	7.5 (1.1-14.4)	1.2 (0.5-2.7)

The frequency of the radiation-related chromosome-type aberrations was significantly ($P=0.046$) higher among the Byelorussian children than among the Finnish children, whereas there was no difference in the frequency of chromatid aberrations, that are not typically induced by ionizing radiation in resting lymphocytes (Table 2). The children from the more heavily contaminated areas of Gomel and Mogil'ov had more chromosome-type aberrations in their lymphocytes than those from Minsk, and the control children from the least polluted area also had the lowest number of aberrations.

The frequency of dicentric chromosomes was almost four-fold (1.5×10^{-3}) in the Byelorussian group as compared to the Finnish children (0.4×10^{-3}); this difference was not, however, statistically significant ($P = 0.167$). An absorbed dose of 100 mGy of ^{60}Co gamma radiation raises the number of dicentric chromosomes to about 4 or 5 per thousand lymphocytes from the control value of less than 1/1000. Assuming a dicentric half-time of 3 years, and that the majority of the radiation dose was delivered shortly after the accident, the average exposure of the children in this group could be as high as 100 mGy. However, this estimate is complicated by an uneven distribution of dicentrics between the cells analysed. As the cesium body contents of the Byelorussian children were similar to that of the Finnish children, most of their radiation exposure must have come from other sources, eg. external radiation.

Table 2 The frequency of chromosomal aberrations among the Byelorussian children and the Finnish controls

Region	No. of subj.	Aberrations per 1000 cells		
		Ct	Cs	Dic, r
Minsk	10	2.0	3.6	1.0
Mogil'ov	15	1.7	4.3	2.0
Gomel	1	5.0	20.0	0
Total	26	1.9	4.6*	1.5
Control	12	1.3	2.1	0.4

* P=0.046, Fisher's exact probability test

Ct, chromatid aberrations; Cs, chromosome-type aberrations; Dic, dicentric chromosomes; r, rings

CONCLUSIONS

Comparison of Byelorussian children to Finnish children showed that their cesium body contents are similar. It thus appears that the Soviet authorities have applied strict dietary restrictions within the areas studied, at least recently. However, the Byelorussian children had significantly higher frequencies of radiation-related chromosome-type aberrations in their lymphocytes.

REFERENCES

1. The International Chernobyl Project, 1991. An Overview. Assessment of Radiological Consequences and Evaluation of Protective Measures. Report by an International Advisory Committee. IAEA, 1991.
2. The International Chernobyl Project, 1991. Surface Contamination Maps. IAEA, 1991.
3. Pohl-Rüling, J., Haas, O., Brogger, A., Obe, G., Lettner, H., Daschil, F., Atzmüller, C., Lloyd, D., Kubiak, R. and Natarajan, A.T., 1991, The Effect on Lymphocyte Chromosomes of Additional Radiation Burden Due to Fallout in Salzburg (Austria) from the Chernobyl Accident, Mutation Research, 262, pp.209-217.
4. Rahola, T., Suomela, M., Illukka, E. and Pusa, S., 1991. Radioactivity of people in Finland 1988. STUK-A91, supplement 2 to Annual Report STUK-A89. Helsinki: Finnish Centre for Radiation and Nuclear Safety, 1991.
5. Arvela, H., Markkanen, M. and Lemmelä, H., 1990, Mobile Survey of Environmental Gamma Radiation and Fallout Levels in Finland after the Chernobyl Accident, Radiation Protection Dosimetry, 32, pp. 177-184.

**STUDY OF AN ACCIDENTAL EXPOSITION OF THREE WORKERS DURING A
GAMMAGRAPHY WITH ^{192}Ir SOURCE**

S.A.BELLINIANI; A.SAHYUN; M.E.GRACIOTTI; O.R.SANTOS;
R.ALVARES

INSTITUTO DE PESQUISAS ENERGETICAS E NUCLEARES -IPEN-CNEN/SP
FAX: (011)2123546 C.P.11049 05499 SÃO PAULO - BRAZIL

ABSTRACT

This paper is concerned with an accident occurred in an industrial gammagraphy unit located in São Paulo, Brazil, on 2nd of July, 1988. A work team, composed of three workers, was engaged on a routine operation with a ^{192}Ir source of 3,299 TBq, when the flexible cable of the holder broke, giving rise to an accidental exposure. The evaluation of the dose received by the three workers was carried out by three different methods: the film badge measurement, the biological dosimetry and the reconstitution of the accident taking into account the exposition time and the distance between the source and the workers. In the film badge evaluation the dose obtained was around 300 mSv, whereas for the biological dosimetry doses of 370 mSv, 290 mSv and 110 mSv was achieved. In the accident reconstitution the doses obtained were: 200 mSv (whole body), 131.000 mSv (left hand) for the first worker; 232 mSv (whole body), 25.000 mSv (left hand), 99.000 mSv (right hand), for the second one and finally 232 mSv (whole body) for the last one. It was concluded, by the evaluation of the doses, that the irradiation was not uniform, being the hand the more severely irradiated organ. From 18th of July, 1988, the victims were treated by the medical staff, together with the radiological protection group, both from the IPEN. In this paper the clinical and laboratorial exams carried out for the evaluation of the extension of the deleterious effects are described. By that time, the victims presented already radiodermatitis in their hands, and the clinical treatment pursued is also described.

SUIVI MEDICAL ET SANITAIRE
DE POPULATIONS VICTIMES DE L'ACCIDENT DE TCHERNOBYL :
PRESENTATION D'UNE EXPERIENCE FRANCO-UKRAINIENNE

A. Moutet, M.L. Simonet*
M. Valenty, C. Bensimon, N. Parmentier, J.C. Nénot, Ph. Hubert**
C. Parmentier, M. Schlumberger***
C. Gicquel****
D.F. Gluzman, O. Vasilenko, M. Abramova, I. Zastanchenko*****
I. Spijenko*****
B. Kouchner*****

* Association "Les Enfants de Tchernobyl"
** Institut de Protection et de Sécurité Nucléaire
*** Institut Gustave Roussy
**** Hôpital Trousseau
***** Institut des Problèmes Oncologiques et de Radiobiologie
Kavetsi de l'Académie des Sciences d'Ukraine
***** Ministère de la Santé d'Ukraine
***** Secrétariat d'Etat à l'Action Humanitaire

MEDICAL AND HEALTH FOLLOW-UP OF
VICTIMS OF THE TCHERNOBYL ACCIDENT :
A FRANCO-UKRAINIAN STUDY

SUMMARY

A Franco-Ukrainian center, devoted to medical follow-up and epidemiological study of 7 000 children who were living in PRIPYAT during the CHERNOBYL accident, was established at the beginning of 1991. After such an accident large numbers of patients and long follow-up are necessary to draw any epidemiological conclusions. However there are important lessons to be drawn from operating experience of the Center. For example it might be felt useful to open others centers. This paper describes the experience acquired during the first 6 months.

INTRODUCTION

Cinq ans après l'accident de TCHERNOBYL, de grandes incertitudes, voire une certaine confusion, règnent dans l'appréciation de ses conséquences médicales. Cette confusion rend difficile la tâche des autorités, mais crée aussi de nombreuses inquiétudes chez les victimes, à la recherche d'informations crédibles sur leur état de santé et sur les risques qu'ils encourent. On décrit ici le bilan du fonctionnement d'un centre médical franco-ukrainien mis en place en 1991.

HISTORIQUE ET OBJECTIFS

Sous l'égide du Ministère de la Santé d'Ukraine et du Secrétariat d'Etat Français à l'Action Humanitaire, une opération axée sur une population particulière a été mise sur pied en 1990.

Elle visait à la fois à fournir une assistance directe aux victimes et à recueillir des informations sur les effets possibles de l'accident et a abouti, en Février 1991 à la mise en place du Centre Médical Franco-Ukrainien de KIEV. Ce Centre, implanté en milieu hospitalier, fonctionne comme un dispensaire, il résulte de l'action de l'Association "Les Enfants de TCHERNOBYL" qui en a été l'initiatrice et qui le gère, de l'Institut de Protection et la Santé Nucléaire (IPSN) du Commissariat à l'Energie Atomique et de l'Institut Gustave ROUSSY (I.G.R.).

L'objectif principal de ce Centre consiste en la surveillance médicale et épidémiologique d'une population bien précise, celle des personnes évacuées de PRIPYAT et des environs relogées à KIEV. Sur 30 000 personnes environ, la priorité pour le suivi est donnée aux 7 000 enfants susceptibles d'avoir été irradiés et/ou contaminés pendant l'accident de TCHERNOBYL. Les personnes suivies subissent un examen complet, avec notamment une recherche des pathologies thyroïdiennes et immuno-hématologiques. Le suivi repose principalement sur le système de santé Ukrainien. Une des originalités du projet réside dans l'alliance de l'action humanitaire et de la coopération médicale et scientifique avec un transfert de compétences. Une autre originalité est le parti pris de s'appuyer autant que faire se peut sur les responsables et les initiatives locales, démarche dictée par le souci de créer un climat de confiance chez des populations méfiantes vis-à-vis des initiatives trop liées aux autorités centrales.

MISE EN PLACE ET RETOUR D'EXPERIENCE ACTUEL

Inauguré le 19 Février 1991, le Centre a atteint son régime de croisière au début du printemps 1991.

Sur place, à plein temps, 3 pédiatres et 2 infirmières ukrainiens, un médecin de l'Association "Les Enfants de Tchernobyl" et une infirmière française bénévole, constituent l'équipe du Centre. En 1991, un premier travail a constitué à mettre l'équipe Ukrainienne en place et à la former à des approches diagnostiques et à des techniques médicales de type occidental. Dans le même temps, le Centre a été équipé, une partie du matériel (analyseur de sang, échographe, ordinateur) étant importé de France. Un stock de médicaments a aussi été fourni au titre de l'aide humanitaire. Parmi les outils spécifiques développés pour cette étude, il faut mentionner le questionnaire à visée médicale et épidémiologique qui comporte trois volets :

- . Une partie signalétique, permettant de repérer l'individu et d'organiser un suivi à long terme.
- . Une partie médicale, réalisée dans l'optique d'un dossier médical, l'accent étant mis sur les pathologies thyroïdiennes et certains paramètres biologiques (numération-formule sanguine et dosage de la TSH).
- . Une partie à visée dosimétrique, visant à reconstituer les localisations successives de l'individu de façon très fine (par tranche de 3 h pendant les premières 48 h, et jour par jour pendant les 8 jours suivants).

Un système de saisie a été conçu pour permettre l'enregistrement direct du questionnaire sur l'ordinateur du Centre.

A la date de ce bilan, 4 mois après l'ouverture, le mode de fonctionnement du Centre peut être considéré comme à peu près définitif. L'équipe de KIEV est secondée par du personnel français envoyé en mission (responsable de l'Association "Les Enfants de TCHERNOBYL", médecin spécialiste, médecin épidémiologiste, informaticien, etc...). La circulation de l'information est décrite par la figure ci-dessous.

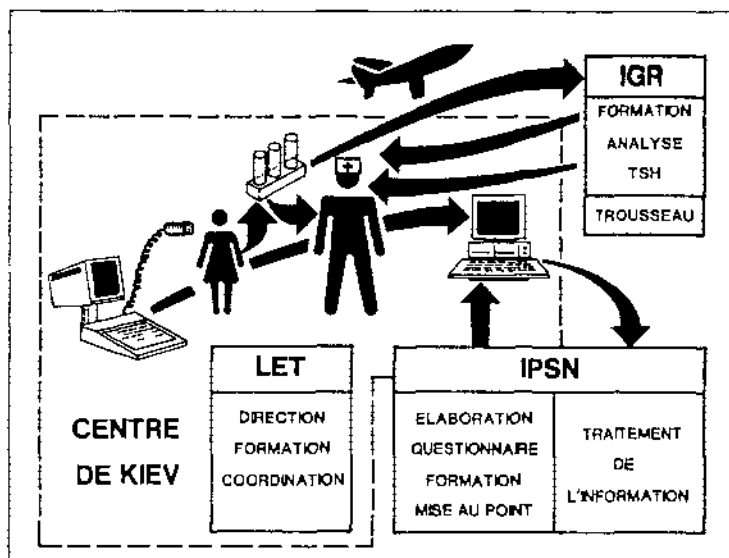

Circulation de l'information

Avant Juillet 1991 (le Centre ferme en été), 953 personnes avaient été examinées ; parmi elles, 808 avaient moins de 18 ans au moment de l'accident et 31 ont été exposées in utero.

Ces premiers résultats permettent de valider le mode de recrutement : les personnes suivies sont convoquées par l'intermédiaire des médecins de quartier et suivies ensuite par le Centre. Les personnes convoquées ont toutes répondu et un climat de confiance paraît s'établir avec le Centre, ce qui justifie le choix initial de s'appuyer sur des relais locaux. Le questionnaire a aussi pu être validé. Quelques modifications mineures sont à envisager dans la partie médicale, et un contrôle de saisie devra sans doute être mis en place localement. La structure générale s'est montrée satisfaisante, et surtout, la partie à visée dosimétrique, a priori très délicate, a très bien été remplie. Les victimes de l'accident ont en effet gardé un souvenir précis de ce qu'elles ont fait pendant les heures et les jours qui ont suivi l'accident.

Les examens systématiques (écographies et dosages de TSH) sur 900 personnes mettent en évidence certaines anomalies, qui ne

s'accompagnent pas pour autant d'une traduction classique ; ces diagnostics nécessitent des confirmations, cas par cas. A cause de ceci, du fait du nombre limité de personnes déjà examinées et à cause de la possibilité d'existence de biais de recrutement qui restent à vérifier, il n'est pas permis d'effectuer pour le moment une interprétation épidémiologique des résultats. Tout au plus peut-on noter qu'une hypothyroïdie a été recensée, dont l'étiologie reste à établir, et qu'aucun cancer ou aucune leucémie n'a été observé sur cet échantillon.

PERSPECTIVES

Au début de 1993, la cohorte des 7000 enfants aura probablement pu être constituée. Même à cette date, les calculs que l'on peut faire à partir de nos connaissances sur les effets des rayonnements et sur les expositions des personnes suivies indiquent qu'il est improbable d'observer des résultats significatifs à cause de la faiblesse du nombre de personnes-années associées au suivi. Ainsi, pour les leucémies, compte-tenu des évaluations dosimétriques publiées par l'AIEA et des facteurs de risque retenus par l'UNSCEAR et le BEIR V, la taille de l'échantillon, plus que le délai écoulé depuis 1986, constituerait le principal handicap pour mettre en évidence un excès statistiquement significatif. Pour les tumeurs thyroïdiennes et les cancers en général la question se pose en des termes un peu différents à cause des longs délais d'apparition (5 à 15 ans après l'irradiation). La cohorte des 7000 enfants serait peut-être assez puissante, mais les difficultés inhérentes à un suivi prolongé, avec ses "perdus de vue" et ses "intrus", risquent d'affaiblir l'étude. En 1993, il est prévu de faire le point sur les "perdus de vue", afin de définir les conditions d'un suivi à long terme de cette cohorte.

En revanche, le simple fait de posséder un bilan descriptif en 1993 présentera un intérêt considérable, car, dans le cas de TCHERNOBYL, les inconnues sont très grandes et des hypothèses bien plus inquiétantes que celles mentionnées ci-avant (sur le plan de l'exposition et de l'effet de l'irradiation) circulent ; les données qui auront été recueillies permettront probablement d'éliminer les plus extrêmes. A titre d'exemple, sur 10 ans, un doublement des taux de leucémies ne serait sans doute pas significatif statistiquement, mais un quadruplement le serait.

Ce projet nécessite encore quelques développements. Les différentes méthodes de reconstitution des doses doivent être examinées (dosimétrie individuelle, reconstitution à partir du terme-source de l'accident, de modèles de diffusion et du comportement des évacués, données initiales soviétiques). L'objectif est évidemment de constituer des groupes d'exposition ; selon la qualité des données disponibles il sera plus ou moins facile à réaliser. Dans une hypothèse défavorable, il faudra créer des groupes en fonction des durées et modalités d'exposition.

Enfin, la mise en place d'autres Centres doit être examinée dans cette optique (groupes à faible exposition ou groupe témoin).

Over-exposure Cases on the Extremities in Radiological Accidents

Tomoko KUSAMA, Yuko BESSHO, Emiko KONISHII, Katumasa OIITA,
Michiaki KAI and Yasuo YOSHIZAWA

Department of Radiological Health, Faculty of Medicine,
The University of Tokyo, Tokyo, JAPAN

ABSTRACT

In a decade, we have treated from medical and radiological viewpoints five males who were over-exposed to direct beam of X-ray on their extremities when they had handled X-ray analysis machine during research or maintenance. All workers except one had worn personal dosimeters on the chest, but not on fingers or wrists. The estimated absorbed dose of the epidermis of the skin performed by a reconstruction of events ranged from 15 to 300 Gy. The causes of accidents in all cases were mishandling of safety system of machine. Clinical syndrome of radiation burn of the skin appeared in all cases and these clinical signs were very useful indicators to estimate dose of each individual.

INTRODUCTION

One of the most important purposes of radiological protection is preventing the deterministic effects of radiation. However, there were some cases of radiation injuries, particularly the radiation burn on hands and faces, quite recently. In a decade, we have treated five male workers over-exposed to X-rays on their hands with radiological and medical cares (1,2,3). Detailed analysis of these accidental subjects from viewpoints of radiological protection is important to prevent further accidental cases in future.

SUMMARY OF INDIVIDUAL CASES INCLUDED IN THIS PAPER

The exposure conditions of each subject are shown in Table 1. Physical properties of irradiated radiation are shown in Table 2. All individuals are male engineers or students. Causes of over-exposure were misuse of safety system of X-ray analytical machine and shortage of sufficient knowledge and perception on radiation safety in workers themselves.

Table 1 Summary of over-exposure by X-ray analytical equipment

Subject	Occupation (age)	Time	Distance	Area	Dose
A	engineer (30)	5 sec	3 cm	50 cm ²	200 Gy
B	engineer (20)	2 sec	0	4 cm ² x 2	300
C	student (22)	20-30 sec	6	4 cm ² x 2	8
D	student (23)	100-150 sec	5	2 cm ² x 3	30-300
E	engineer (20)	4-5 sec	10	20 cm ²	300

Table 2 Physical properties of exposed radiation from X-ray analytical equipment

Subject	Voltage	Current	Additional filter	Effective energy
A	50kV	20mA	-	10 keV
B	50	30	-	10
C	30	20	-	9
D	50	50	-	9
E	40	200	-	10

ESTIMATION OF ACCIDENTAL EXPOSED DOSE

Four cases were wearing personal dosimeters on the trunk when they were clearly exposed, but as irradiated areas were limited to only a part of the body, the dosimeters did not include exposed direct beam of X-rays. Therefore, their dosimeter recorded zero. One case, a college student, did not wear personal dosimeter because he was not registered as a radiation worker. In all cases, personal dosimeters on the wrist or finger were not worn; thus, in all cases, the doses to the exposed parts of the hands were not given by personal dosimetry. So we estimated dose by reconstruction of events after each accident. The detailed information of exposed time, distance, shielding and source strength were taken from interview of both subject and radiation safety officer immediately after exposure. Exposure doses were measured with the following equipment in the experiment of the reconstruction;

Ionizing chamber : CAPINTEC Model 192 (probe volume;6cc)
 Thermoluminescence dosimeter : CaSO₄, BeO

The estimated absorbed dose of epidermis of each case by reconstruction are shown in Table 1. Each estimated dose had uncertainty factor 2 to 3, because exposed times at the accident were equivocal. We considered that the clinical manifestations on the skin after accidents were the most valuable indicators for dose estimation. We did not perform biological estimation of dose, that is analysis of chromosome aberrations and hematological examination of circulating blood; because irradiated area was a very restricted volume, we considered that dose could not be detected by these biological analyses.

CLINICAL SIGNS AND TREATMENT

Acute and chronic syndromes of the radiation burns appeared in all subjects with some period of latency. Typical acute syndromes that appeared in each case were erythema, dry and wet desquamation, dermal oedema, blister and erosion. These acute syndromes disappeared in two or three months after exposure and chronic syndrome appeared after 9 or 18 months after events. In one case, chronic syndromes appeared without a break from acute syndromes. Typical chronic syndromes in all cases were ulcer, necrosis, hyperplasia, telangiectasis, pigmentation, dis-pigmentation and atrophy. The points of medical care of subjects were cleaning of the exposed area and giving it a good rest. Four cases were treated with non-surgical conservative therapies and one case was treated with surgical skin graft therapy.

Clinical manifestations, particularly the length of latencies of acute syndromes, were very useful information for dose estimation in individuals not wearing personal dosimeter. The times of appearance of each acute syndrome in individuals are shown in Fig.1.

ADMINISTRATION ACTION

(1) Improvement of safety equipment

All equipment was provided with safety lock system. However, many workers frequently ignored these safety systems while operating the machine. At the time of accident, the functions of safety systems were not effective in any of the cases reported in this paper. Then deep defense systems of safety were introduced.

(2) Creation of a formal management structure and operational guidance

New effective organizations for radiation protection and manuals of good practice expressed in clear terms were prepared in all institute after the accidents.

(3) Training and skill for radiation workers

Special training and skill were performed to establish a safety-based attitude in everyone concerned with operations of X-ray analytical machines in each institute. There were many types of machine and various techniques of utilization of X-ray analytical machine; thus, details of training concerning safety and protection depended on the type and technique of operating machine and degree of worker's skill.

(4) Lay-off from radiation work

All cases were permitted the subsequent employment in the same duties of radiation work from clinical and radiological consideration; however, the duties of all cases were modified from radiation work to non-radiation work as required by each individual.

DISCUSSION

(1) Biological dosimetry of very small part of the skin

Analysis of chromosome aberration in peripheral lymphocytes has usually been performed in accidental cases, but, in the cases where the irradiated area or volume is very small, chromosome analysis does not detect irradiation dose. Then, other biological dosimetric system must be investigated; particularly useful indicators under the dose range are the appearance of clinical manifestation, that is erythema and epilation. Now we research growth retardation of hair after over-exposure of skin as a biological indicator (4).

(2) Dose estimation of very low energy of X-ray

In cases of irradiation by X-ray analytical machine, the energies of radiation were very low, under 10 keV. The response of present dosimetric equipment, TLD, depends on energy of exposed radiation. The equipment is over-responsive in these energy ranges. Then, we employed a method of two kinds of TLDs, which are different in effective atomic number, to correct X-ray energy response.

(3) Shortage of knowledge of radiation safety and protection of workers

Our previous studies made it clear that the understandings of managers and workers for radiation protection were lacking. The most important aspect of radiation safety and protection is the close links between managers and workers. All persons concerned with radiation work must have appropriate knowledge of safety of radiation.

CONCLUSION

We have treated five male workers who were over-exposed to X-rays on their hands with doses from 8 to 300 Gy. The experience of detailed analysis of these subjects suggested that it is important to practice appropriate pre-operational and periodical education and training for workers on radiological safety and protection.

REFERENCES

- (1) Y. Yoshizawa and T. Kusama : Medical Treatments of Radiation Injuries. J. Japan Medical Association (2769) 27-29 (1987)
- (2) Y. Yoshizawa, E. Konishi, T. Tabara and T. Kusama : The case report of accidental exposure on the extremities. (In) Proceedings of 19th Ann. Meeting of Japan Health Phys. Soc. 6 (1984)
- (3) K. Ohta, M. Kai, T. Kusama and Y. Yoshizawa : The case report of over-exposure on the hands by X-ray analytical machine. (In) Proceedings of 23rd Ann. Meeting of Japan Health Phys. Soc. 74 (1988)
- (4) Y. Bessho and T. Kusama : Hair growth as a biological dosimeter for over-exposure of skin. (In) Proceedings of 26th Ann. Meeting of Japan Health Phys. Soc. 76 (1991)

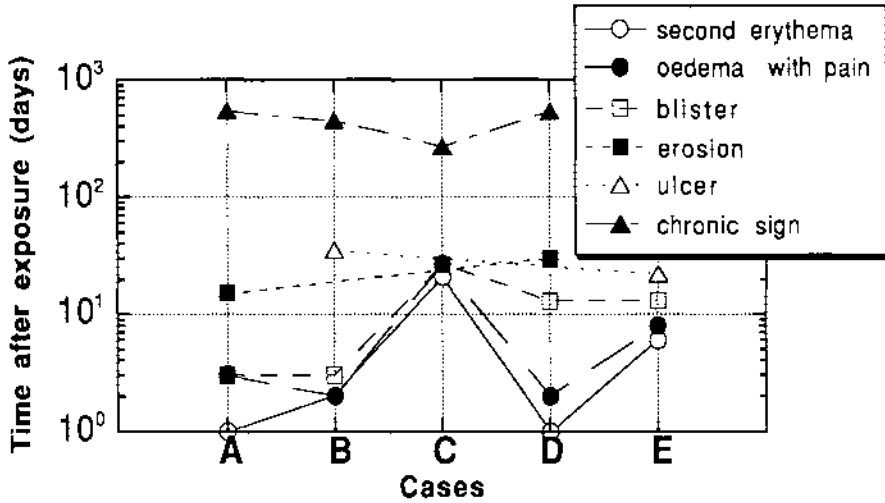

Fig.1 Clinical manifestation of each case.

RADIOTOXICOLOGICAL ASSESSMENT OF BURNS CONTAMINATED BY NITRIC
SOLUTION OF PLUTONIUM

J. Piechowski,
CEA/Institut de Protection et de Sûreté Nucléaire,
Département de Protection de la Santé de l'Homme et de
Dosimétrie, BP 6, 92265 Fontenay aux Roses Cedex, France.
J. Benoit, J. Mercier,
COGEMA/Marcoule, BP 170, 30205 Bagnols sur Cèze Cedex, France.
P. Thomas, J.C. Harduin,
COGEMA/La Hague, BP 508, 50105 Cherbourg Cedex, France.

Skin burn by nitric solutions of plutonium is a possible way of contamination during fuel reprocessing. Two well documented cases have been analyzed. They show that the initial transfer of Pu through the skin is very important. Conversely, there is practically no long-term release of Pu from the burn. Consequently, DTPA therapy can be considered as a medical emergency whereas there is no urgency for an eventual surgical operation.

In fuel reprocessing plants, the Occupational Physician may occasionally come across cases of burns contaminated with plutonium in nitric acid solutions. A long-term follow-up of excretion is necessary in order to assess the systemic burden correctly.

Initial urinary excretion, over about the first ten days following the incident, is essentially attributable to the activity that has passed rapidly into the blood. Measurements performed during this period represent the sum of the excretion relative to systemic burden and of the activity released from the burn, washed away by the circulating DTPA. Excretion over medium and long periods is more difficult to interpret. Measurements performed beyond the first month allow a theoretical determination of the activity transferred very slowly to the blood.

Two examples are presented. The theoretical function of urinary excretion relative to the activity that is rapidly transferred to the systemic target tissues (1, 2) allows us to find the systemic burden by applying a factor of 50 for the action of DTPA. The margin of uncertainty, taking into account the variability of DTPA action (25 at least, 100 at most), is shown by a hatched band. It is obvious that an interpretation with a view to determine a long-term released activity could have been envisaged only if several points had been situated clearly above this band beyond one month. As this is not the case, it can be considered that the long-term release of activity from the burn is virtually non-existent.

In the examples treated, only the rapid transfer component participates in the systemic burden. Internal exposure thus results from the activity which passes in the blood through at the time of the incident or in a few hours thereafter. Emergency medical therapy, i.e. the administration

of DTPA as soon as possible, washes away the plutonium released from the burn.

The local activity which persists for long periods seems above all to be "inert", not at all or very little metabolizable. It is not possible to show a component of slow transfer to the blood. This suggests that, contrary to the medical action which should be very rapid, possible surgical action can be calmly prepared for reducing to a minimum any anatomical and functional risks.

The argument of local dose may be raised, but it should be tempered in view of the very small distance travelled by the radiation and of the very low probability of alpha particles hitting critical target cells. If an excision is performed, it actually removes the irradiated tissues, thereby eliminating the associated risk of a high local dose.

REFERENCES

1. Durbin, P.W., 1972, Plutonium in Man: a New Look at the Old Data, Radiobiology of Plutonium, Eds. B.J. Stover and W.S.S. Jee, Salt Lake City: The J.W. Press, 469-530.
2. ICRP Publication 48, 1986, The Metabolism of Plutonium and Related Elements, Ann. ICRP 16(2/3), Oxford : Pergamon Press.

ACKNOWLEDGEMENTS

We would like to thank Dr. J. JEANPIERRE for providing the data of the case B and Mrs B. MENOUX for elaborating the excretion curves software.

COMMENTARY ON THE FIGURES

Case A : Burn of about 4 cm² located on the left forearm, plutonium was in nitric acid solution N 13; initial local activity 600 Bq; excision on day 20; assessment of systemic burden: 2 to 6 Bq.

Case B : Burn of about 48 cm² located on the right thigh; plutonium in nitric acid solution N 6 to 8; initial local activity: 50 kBq; no excision; assessment of systemic burden: 1 to 4 Bq.

The hatched bands give an estimate of the activity excreted relative to the systemic burden. The margin of uncertainty takes into account the variability of DTPA action (25 at least, 100 at most).

(a): the initial values above the hatched band represent the activity released from the burn, immediately trapped by DTPA and eliminated in urine.

(b): the measurement results located in these areas correspond to urinary excretion without DTPA; the points between square brackets represent results below the limit of detection.

(c): no value does appear above the hatched band; it means that there is no long-term release from the burn.

PLUTONIUM

OBSERVED DAILY URINARY EXCRETION RESULTING FROM A CONTAMINATED BURN

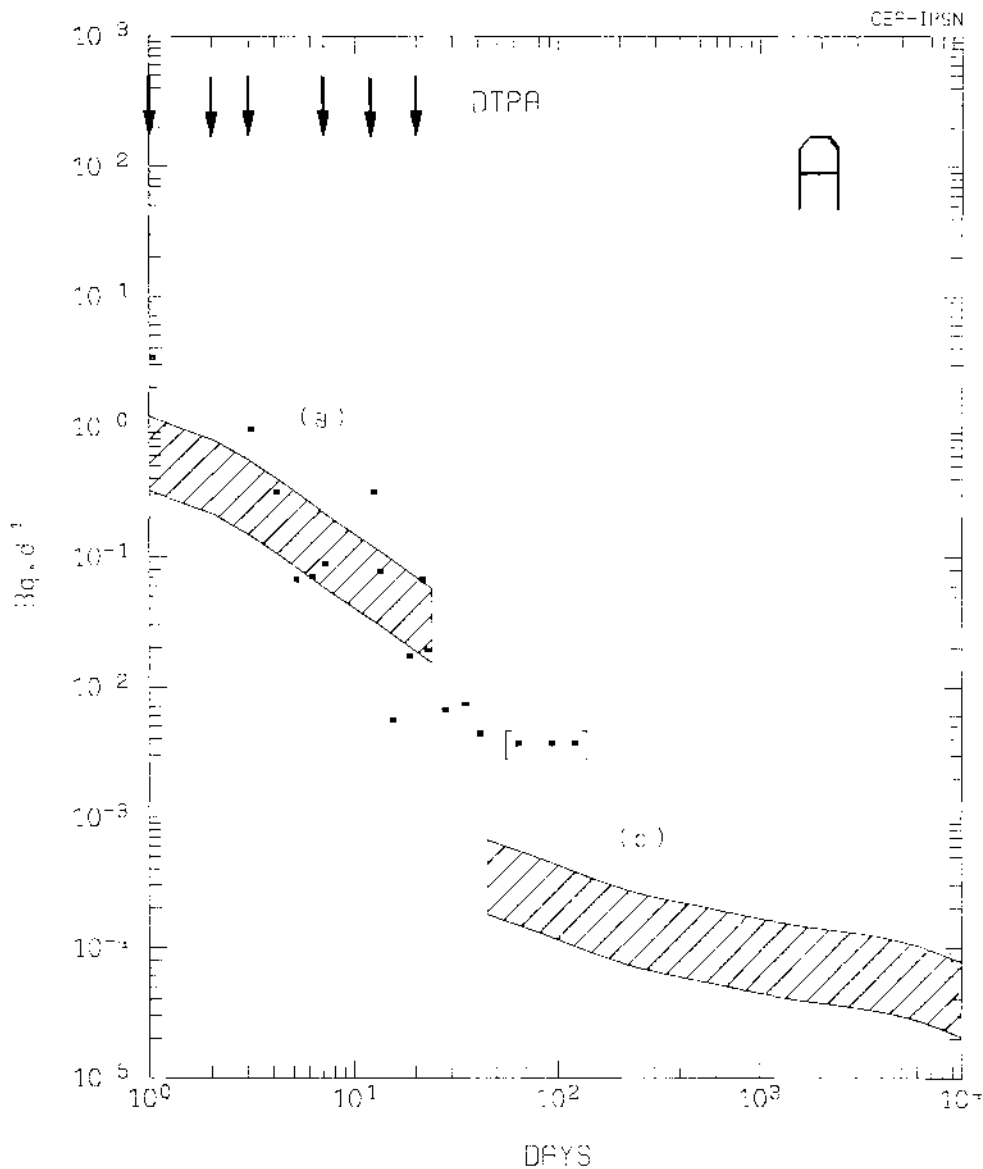

PLUTONIUM

OBSERVED DAILY URINARY EXCRETION RESULTING FROM A CONTAMINATED BURN

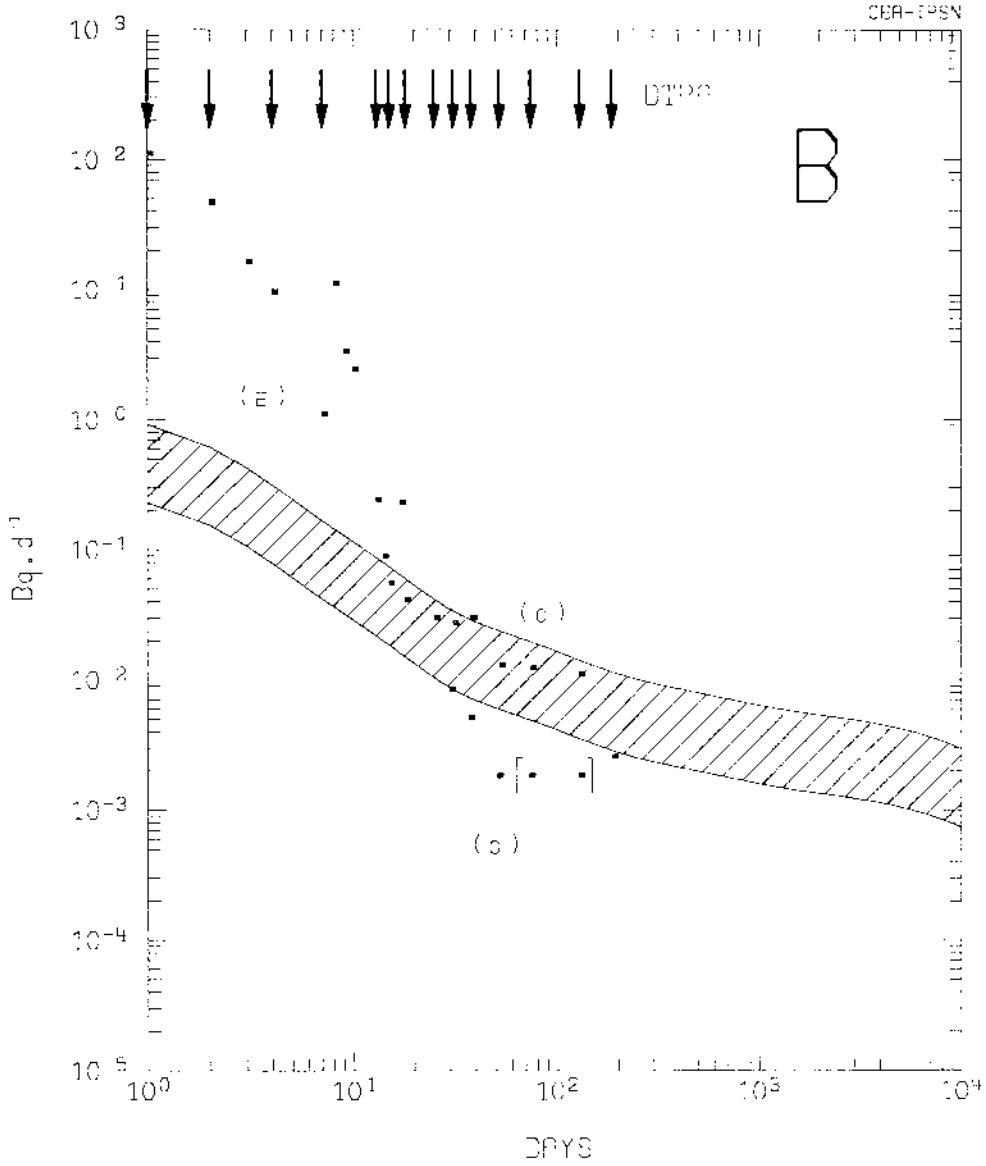

**AIDE INFORMATISEE A L'ORGANISATION DES SECOURS MEDICAUX SUR SITE
DANS LE CADRE D'UN ACCIDENT DE GRANDE AMPLIEUR EN CENTRALE NUCLEAIRE**

M. TEISSIER

**Médecin du travail, E.D.F. Centre de Production Nucléaire, BP 30
07350 CRUAS**

**COMPUTER AID IN RESCUE ORGANISATION ON SITE
IN CASE OF CATASTROPHIC SITUATION ON NUCLEAR PLANT**

The rescue organisation in case of catastrophic situation is based on known principles : creation of medical buffer structures between hazard spot where injured people are being collected and rear hospitals, triage of victims as urgent casualties.

We will propose computer aid in order to value the time used to prepare and evacuate all the victims from the site, knowing inventory of available means, waiting periods and lengths of intervention, types and number of victims. Thus, it is possible to optimize the former organisation, qualitatively and quantitatively to improve efficiency in rescuing operations.

INTRODUCTION

L'accident survenu à la centrale nucléaire soviétique de Tchernobyl le 26 avril 1986 a rappelé la nécessité d'une préparation optimale des plans de secours.

Si l'essentiel de cette préparation en ce qui concerne la population est à la charge des pouvoirs publics ("Plan Particulier d'Intervention"), le médecin du travail se doit de participer à la mise en place et à l'organisation des secours pour les travailleurs dont il a la responsabilité ("Plan d'Urgence Interne").

1 POSITION DU PROBLEME

Il importe tout d'abord de limiter notre champ d'action à la fois dans l'espace : secours aux personnes présentes sur le site (travailleurs, sauveteurs, visiteurs éventuels) et dans le temps : phase précoce de l'accident que l'on considèrera comme achevée lorsque toutes les victimes du site auront, après avoir reçu les soins immédiats nécessaires, été évacuées.

Notre objectif sera alors la prise en charge la plus efficace et dans les délais les plus courts possibles de chaque victime prise isolément et ce à chaque étape de la chaîne des secours qui comprend un relevage des premiers soins et une évacuation ; chaque étape étant dans la mesure du possible médicalisée.

1.1 Victimes en petit nombre (< 3)

Les moyens à mettre en oeuvre tant en matériel qu'en personnel sont en général faciles à créer ou à mobiliser car déjà disponibles à l'extérieur, les procédures d'alerte et de premiers secours assez faciles à organiser.

Par sa spécificité la pathologie nucléaire impose néanmoins, soit de s'adresser à des secours extérieurs compétents en ce domaine (Hôpitaux universitaires, armée), soit de former le personnel interne pour servir de spécialiste accompagnant au personnel habituellement confronté aux urgences dans le secteur concerné.

1.2 Victimes en nombre important (>3)

Les sites nucléaires français comportent souvent quatre unités dont l'effectif en personnel dépasse 1 000 personnes. Il peut exister un nombre important d'impliqués : personnes indemnes qu'il importe néanmoins de contrôler sur le plan radiologique.

Nous nous trouvons alors en inadéquation temporaire entre les moyens mis à disposition pour les secours et les besoins : c'est un contexte de médecine dite de catastrophe. Les grands principes en sont connus et deux sont essentiels : trier les victimes et créer un centre tampon précédant les structures habituelles de soins à l'extérieur. C'est le rôle du centre de tri et de soins (CTS) qui peut se dédoubler en poste médical avancé (PMA) et centre médical d'évacuation (CME).

Il faut établir l'inventaire des moyens à notre disposition tant en personnel qu'en matériel (interne au site, Services médicaux d'urgence, sapeurs pompiers, ...), en discuter l'opportunité et agir en conséquence.

Il faut optimiser leur répartition et leur mise en oeuvre de façon à éviter le problème majeur de ce type de situation : l'attente tant du côté de la victime que du sauveteur : attente des victimes ayant pour conséquence une augmentation de la morbidité et de la mortalité globale, attente des sauveteurs ayant au minimum une conséquence sur le plan économique ne serait-ce que par une surestimation a priori des moyens.

2 CHOIX D'UNE SOLUTION

2.1 Approche habituelle

C'est une approche pragmatique fondée sur le retour d'expérience. Il en est résulté des solutions types adaptées à quelques cas-types ne faisant pas toujours l'unanimité parmi les intervenants concernés. L'adaptation de la montée en puissance se fait au vu de l'évolution de la situation. Dans le secteur nucléaire, les accidents de ce type ont été fort heureusement rares et nos confrères soviétiques sont restés relativement discrets sur cette phase précoce et localisée au site de l'accident.

Cette approche est néanmoins une source indispensable de renseignements quantitatifs issus des statistiques disponibles en ce qui concerne les délais d'intervention, les durées moyennes de conditionnement des blessés...

2.2 Approche de type ordonnancement

Nous avons tenté une modélisation du déroulement des secours à l'aide de la méthode des graphes qui consiste à découper l'ensemble des actions à effectuer en tâches élémentaires de durée déterminée, puis à mailler par des chemins logiques l'ensemble de ces tâches.

Certaines tâches peuvent être effectuées simultanément : un blessé pourra être évacué pendant le conditionnement d'une autre victime si les moyens sont suffisants.

Certaines tâches doivent être effectuées successivement : tous les blessés seront d'abord conditionnés puis ils seront évacués l'un après l'autre au moyen d'une noria si une seule équipe médicale munie d'un véhicule d'évacuation est disponible.

L'ensemble des opérations de secours se passent par ailleurs sous contrainte de durée : une urgence absolue doit arriver en moins de 6 heures en milieu chirurgical, une urgence relative en moins de 18 heures (durées proposées par les médecins militaires que nous avons volontairement de beaucoup réduites). Dans ces problèmes très combinatoires dès qu'un grand nombre de variables apparaissent, l'informatique permet d'optimiser plus facilement les moyens pour les objectifs que l'on s'est préalablement fixés.

2.3 Présentation du programme

Le programme permet de simuler le déroulement des secours dans le cadre de l'organisation que nous lui avons fixée a priori : une chaîne de secours traumatologique avec ou sans caractère radiologique, une chaîne de secours radiologique isolée s'occupant essentiellement du contrôle de personnes.

Les données d'entrée comprennent :

. Des variables (10) concernant le nombre et la nature des victimes ; nous avons créé à ce propos une typologie adaptée à la prise en compte de la durée et de la qualification nécessaires des intervenants en ce qui concerne les classes de victimes. Ces valeurs sont fonction de l'accident envisagé.

. Des paramètres (21) propres à la configuration du site (déterminés par des exercices) et aux moyens disponibles en ce qui concerne les délais et durées d'intervention et les effectifs de ces moyens.

Pour un type d'accident donné l'essai de différents paramètres en ce qui concerne les moyens, fournit en temps réel la durée totale de l'intervention telle qu'on l'a définie précédemment et les durées partielles sur lesquelles il est judicieux de porter son effort (c'est la recherche du chemin critique).

3 APPLICATION PRATIQUE ET PRECAUTIONS D'UTILISATION

L'aide informatisée ne supprime pas la réflexion, elle ne prend pas par elle même de décision !

Il y a tout d'abord à s'interroger sur les incertitudes liées aux paramètres d'entrée : la durée du conditionnement du blessé peut être éminemment variable. On peut dire que plus il y a de victimes, plus la durée moyenne se stabilise, mais la distribution de ces durées est à prendre en compte dans une file d'attente.

Il y a aussi à s'interroger sur la robustesse aux nécessaires simplifications introduites dans notre modèle figé dans son organisation : la montée en puissance des contre-mesures à la fois progressive et cahotique est difficile à introduire mais ceci peut s'améliorer.

Nous estimons mal enfin le facteur de viscosité introduit par le climat psychologique inhérent à ce type de situation.

Actuellement ce programme nous a servi à l'aide de scénarios plausibles d'accidents que nous avons analysés, à déterminer des ordres de grandeur d'effectifs et des choix quant à la nature des moyens de secours, ceci nous permet de créer des exercices qui nous servent eux même à valider le modèle.

Nous espérons ne pas le voir utilisé en temps réel, mais il pourrait sans doute y apporter une aide.

BIBLIOGRAPHIE

NOTO R, HUGUENARD P, LARCAN A. Médecine de catastrophe. Masson éd. 1987.

Exemple : sortie résultats sur MACINTOSH

EFFECTIFS DES VICTIMES

SECOURS SC 1-3

BLESSES (cont et/ou irr ou non)	B-	15
dont BLESSES GRAVES	Bbb-	15 par défaut: 5
dont BLESSES LEGERS	Bb-	0 par défaut: 10
dont BLESSES CONTAMINES	BC-	0
dont BLESSES IRRADIES	BI-	0
SUSPECTES DE CONTAMINATION	Csu-	0
dont TROUVES CONTAMINES APRES DETECTION	Cc-	0
dont CONTAMINES INTERNES PROBABLES	Ccc-	0
SUSPECTES D'IRRADIATION	I-	0
contaminés internes probables & suspects d'irr	Cccl-	0

PARAMETRES (Durée moyenne intervention) (mn)

ARRIVEE SECOURS AUPRES BLESSE	TEA-	15
DEGAGEMENT RELEVAGE BLESSE	TEB-	10
ALLER/RETOUR EVACUATION ZONE-CTS	TEP-	10
SE RENDRE POINT REGROUPEMENT	TEG-	0
ALLER/RETOUR NAVETTE PT RGPT-CTZ	TEN-	0
PREMIERS SECOURS SUR PLACE BLESSE	TSS-	10
REANIMATION AU CTS BLESSE	TUA-	20
SOINS COMPLEMENTAIRES AU CTS BLESSES	TUR-	10
INTERVENTION COMPL. BLESSES CONTAMINES	TUC-	0
CONTROLE CONTAMINATION AU PT RGPT	TCM-	0
DECONTAMINATION EXTERNE AU PT RGPT	TCE-	0
CONTROLE CONTAMI. INT. + SOINS COMPL. AU CTS	TCI-	0
PRELEVEMENT POUR IRRADIATION	TII-	0

PARAMETRES (effectifs des ressources)

SOMMES DES PLACES YSAB ZONE-CTS	NEP-	2
SOMMES DES PLACES NAVETTES PT RGPT-CTS	NEN-	0
NOMBRE SECOURISTES OPTIMAL (Calcule)	NSS-	30
NOMBRE MEDECINS	NUA-	2 OPTIMUM: 5
NOMBRE INFIRMIERS	NUF-	3
UNITES DE DETECTION CONTAMINES AU PT RGPT	NCK-	9
UNITES DE DOUCHES DECONTAM. EXTERNE AU PT RGPT	NCE-	9
UNITES DE MESURE CONTAMINATION INTERNE AU CTS	NCI-	3

RESULTATS DUREE RESOLUTION CRISE

DUREE TOTALE (Victimes conditionnées prêtes ou déjà évacuées=	D-	200 mn
		3,20 hh,mn
dont FILE BLESSES (contaminée et ou irr. ou non)	DX-	200 mn,
dont mise en condition secouriste et attente YSAB site	DDS-	20 mn
dont évacuation complète zone-CTS	DEP-	75 mn
dont soins médicaux au CTS	DUB-	175 mn
dont FILE DETECTION & DECONTAM. EXTERNE AU PT RGPT	DY-	0 mn
dont détection contamination	DCM-	0 mn
dont décontamination externe & vérification	DCE-	0 mn
dont évacuation cont int et/ou irr potentiels complète zone-CTS	DEN-	0 mn
dont contrôle prélèvement & soins compl cont int, irr au CTS	DUN-	0 mn

EFFECTS OF POWDERED OYSETER SHELL ON DECORPORATION OF PLUTONIUM

S. Fukuda and H. Iida

Division of Comparative Radiotoxicology, National Institute of Radiological Sciences, Chiba, Japan

ABSTRACT

Active amino acid calcium (AAACa), a natural product which oyster shell electrolysate and seven amino acids were mixed, has strong bioavailabilities that can raise the serum level of calcium and affects on bone metabolism, by the action of high calcium intestinal absorption. This compound may be expectable as a abetting agent to reduce the risk of plutonium or other bone seeking radionuclides-induced cancers because it has beneficial effects to decorporate plutonium from bone and liver.

INTRODUCTION

Chelation agents such as DTPA (Diethylenetriaminepentaacetic acid) can decorporate effectively plutonium and other actinides, however the practical use for human is limited by the many unavoidable toxic side effects and the time of use.

AAACa is one of natural foods that the main component, CaO, of oyster shell electrolysate which is easily ionizing and the seven kinds of amino acids such as valine containing in seaweeds that has an action of active calcium transport [1,2] are mixed. Recently it was demonstrated that AAACa has beneficial effects to prevent and treat especially osteoporosis [3] and hypertension without side effects, indication it has a strong bioavailability against calcium and bone metabolism.

The present study was performed to examine the effects of AAACa to decorporation of plutonium particularly from bone in rats.

MATERIALS AND METHODS

Twenty five rats, 3 months-old, were divided into the following five groups: group A was give a control standard diet (1 % CaCO₃). group B was given a 1 % AAACa diet immediately after plutonium injection. group C was given a 1 % AAACa diet 1 week before plutonium injection. group D was given a 1 % AAACa diet and injected intra-peritoneally once a day a daily dose of 150 μ mol/kg body weight Ca-DTPA. group E was given a control diet and injected the same schedule of Ca-DTPA as that of group D.

Rats were injected intravenously plutonium under anesthesia and sacrificed 14 days later. The femur and liver were removed. The excreta, separated and feces urine, were collected at 24-hr intervals. Plutonium activity of these samples was measured by an alpha liquid scintillation counter after wet ashing.

RESULTS

The plutonium contents of skeleton were reduced to 63.6 % in the group B, 58.9 % in the group C, 10.4 % in the group D and 19.0 % in the group E, whereas the control was 69.3 %. Those of liver were 6.93 %, 6.43 %, 0.22 %, and 0.35 % in each B, C, D, E group, whereas the control was 7.74% (Fig 1).

DISCUSSION

The data obtained showed that AAACa can remove plutonium from not only bone but also liver, and a combination of it and Ca-DTPA can promote the reduction of plutonium contents in these organs. The possible mechanisms are considered that rapid absorbed and increased ionic calcium in serum covered the osteoid surface of trabecula bone, followed the inhibition of plutonium deposition in bone, and affected on some changes to the functions of osteoclasts and liver cells bone cells. The results indicated that particularly a long term dietary AAACa supplement has beneficial effects to reduce the risk of radionuclides-induced cancers and is expectable as one of agents to use practically and immediately to prevent and treat for human exposure without toxic side effects.

REFERENCES

- [1] Fujita, T., Orimo, H. and Yoshikawa, M., 1961, Hyper- and hypocalcemic effects of amino acids in parathyroidectomized rats, *Endocrinology*, 78, 1082-1084.
- [2] Fujita, T., Fukase, M., Nakada, M. and Koishi, M., 1988, Intestinal absorption of oyster shell electrolysate, *Bone and Mineral*, 4, 321-327.
- [3] Fujita, T., Fukase, M., Miyamoto, H., Matsumoto, T. and Ohue, T., 1990, Increase of bone mineral density by calcium supplement with oyster shell electrolysate, *Bone and Mineral*, 11, 85-91.

Fig.1 Plutonium contents of femur 14 days after Pu injection

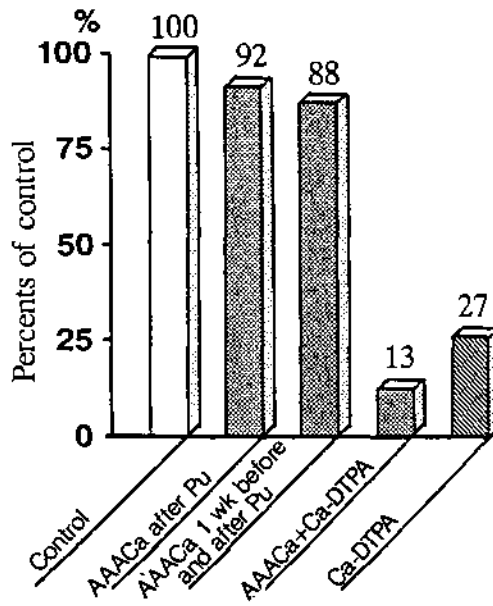

Plutonium contents of liver 14 days after Pu injection

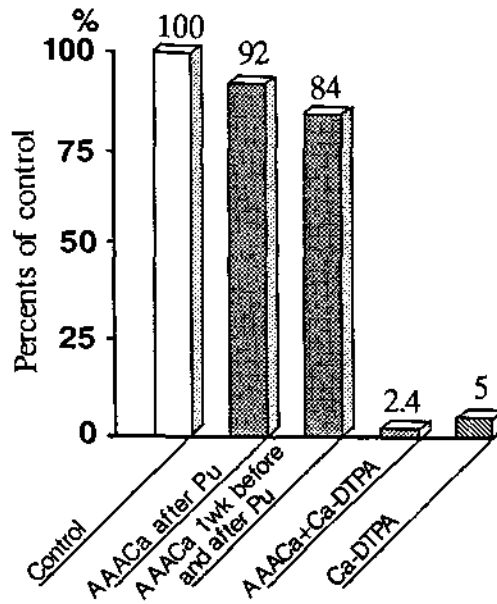

RADIOLOGICAL PROTECTION AT PARTICLE ACCELERATORS: AN OVERVIEW

Ralph H. Thomas

University of California
School of Public Health
Berkeley, California
and
Lawrence Livermore National Laboratory
Livermore, California

"Igneus est ollis vigor...seminibus."
Virgil, *Aeneid* VI, 730 (ca. 50 B.C.)

ABSTRACT

Radiological protection began with particle accelerators. Many of the concerns in the health physics profession today were discovered at accelerator laboratories. Since the mid-1940s, our understanding has progressed through seven stages: observation of high radiation levels; shielding; development of dosimetric techniques; studies of induced activity and environmental impact; legislative and regulatory concerns; and disposal. The technical and scientific aspects of accelerator radiation safety are well in hand. In the U.S., there is an urgent need to move away from a "best available technology" philosophy to risk-based health protection standards. The newer accelerators will present interesting radiological protection issues, including copious muon production and high LET (neutron) environments.

INTRODUCTION

The elegant work of Cockcroft and Walton at Cambridge and Lawrence at Berkeley was reported in that *annus mirabilis* of nuclear physics, 1932; as a result, this is regarded as the year in which particle accelerators were invented. However, accelerators are 35 years or more older. Since the time of J. J. Thomson's cathode-ray tube (1894) and the discovery of Roentgen rays (1895), particle accelerators have been associated not only with major discoveries in atomic, nuclear, and fundamental particle physics but also with radiological protection.

Accelerators were first developed as research instruments, and thus, many of the concerns that now occupy health physics were first identified at accelerator laboratories. Accelerators were the first to produce the symptoms of the acute radiation syndrome; induced radioactivity; radiopharmaceuticals; transuranic elements; and by an accelerator-derived instrument, the calutron, fissile and fissionable materials. It was at an accelerator laboratory that the first studies of the radiotoxicity of the alpha-emitting transuranic elements were made. Nevertheless, accelerator radiological protection is largely perceived as something of an academic backwater aside from the mainstream; many of the subdisciplines that began at accelerators are now so large in scope that they have become separate fields of endeavor.

HISTORICAL OVERVIEW

After the Second World War, studies of the radiological environments of accelerators began in earnest, following the work started during the Manhattan Project. Our understanding of the development has been reviewed by Perry et al. (1991), who suggested that it occurred in seven stages:

1. Observation of high radiation levels.
2. Shielding studies.
3. Radiation dosimetry.

4. Studies of induced activity and radiation damage.
5. Environmental impact.
6. Legislation and regulation.
7. Disposal.

Each of these aspects will be briefly discussed.

HIGH-RADIATION LEVELS AND SHIELDING STUDIES

Many years before nuclear reactors operated, the early accelerators were powerful neutron sources. In the late 1940s and early 1950s, many accelerators of various types were constructed in several different countries. Performance often exceeded expectations, and high beam intensities led to the production of high, unwanted, ambient radiation levels. Two immediate necessities resulted: (1) to shield and (2) to quantify radiation fields.

Incentives were greatest at laboratories, like Berkeley, where new accelerators had been built aboveground and with very little shielding. At the early synchro-cyclotrons buried in the ground, radiation problems were avoided, but at the cost of no improvement in understanding. The progress of shielding studies has been extensively documented in several texts to which the interested reader is referred. Suffice it to say that nowadays, accelerator shields may be defined with considerable confidence and efficiency (Patterson and Thomas, 1973; Swanson, 1979; Thomas, 1988; and Fassò, 1990).

RADIATION DOSIMETRY

Swanson and Thomas (1990) assert it is at accelerators that "the science and technology of radiation dosimetry are at their most sophisticated. In only one other class of radiation environments—those met in extraterrestrial exploration—do such novel and diverse dosimetric challenges need to be faced. Even here the dosimetrist does not encounter the range of particle intensities, variety of radiation environments, or pulsed characteristic of radiation fields."

These authors give detailed descriptions of the dosimetric systems that have proved useful in accelerator environments where measurements are made for many purposes, above and beyond the need to determine personnel exposure. Techniques that determine the physical characteristics of the radiation environment are preferred to attempts avoid the complex problem by expressing measurements in terms of a single scalar quantity, such as equivalent dose.

Philosophers might reflect on the vicissitudes of the dose-equivalent system over the past decade: the system is now so complex when applied to mixed radiation fields that it has lost its original intended virtue of simplicity.

INDUCED RADIOACTIVITY

The largest contribution to collective dose equivalent resulting from accelerator operation arises during repair, maintenance, and modification. While these doses mainly result from photons, the detailed inventory of radionuclides in accelerator environments differs from that found at nuclear reactors. High-energy hadron reactions tend to produce radionuclides that are neutron deficient and many decay by positron emission or electron capture (e.g., ^7Be , ^{54}Mn , ^{51}Cr).

In the decade from 1975 to 1985, there has been a general tendency for the annual collective dose equivalent at accelerators to fall by about a factor of 3. Typical collective dose equivalents at large accelerator facilities range from a few tens to a few thousand millisievert (Perry et al., 1991).

ENVIRONMENTAL IMPACT AND DISPOSAL

Accelerator operation may expose the general public by four pathways. In order of importance they are

- Prompt radiation;
- Production of radionuclides and noxious chemicals, and release to the environment;
- Production of radionuclides in soil and groundwater near the accelerator and possible migration to water supplies;
- Radioactivity produced in materials of accelerator components that may be subsequently recycled or released to the general environment.

Measurements of the transport of neutrons to large distances (on the order of km) from the roof-less synchrotrons began at Brookhaven and Berkeley in the 1950s. These studies have been refined over the past 30 years, and this source of environmental impact is now well understood (Thomas and Stevenson, 1988; Stapleton et al., 1991; Stevenson and Thomas, 1984).

No significant population dose is expected from the latter two pathways and the second pathway is of less consequence than the first by an order of magnitude (Thomas and Rindi, 1979; Goebel, 1987).

LEGISLATION AND REGULATION

In the United States, perceptions of increasing concern for health by the general public have led legislators to reduce allowed radiation exposures to the general public using legislative and regulatory means regardless of cost. Such regulation often takes the form of control by the "best available technology"—and this often translates into merely what minimum level may be measured—rather than any assessment of risks to public health.

Such a process has resulted in a set of protection standards promulgated by the U.S. Environmental Protection Agency that is disparate and illogical. For example, under the Clean Air Act, radioactive emissions are limited to produce an annual dose equivalent of no more than 100 μ Sv. However, if these radionuclides were waterborne, the committed dose-equivalent limit would be 40 μ Sv. The annual limit for all radiation exposure from both external and internal sources is 1000 μ Sv. One wonders how the particular biological structure being irradiated discerns the specific origin of its own radiation exposure!

RADIOLOGICAL PROTECTION AT PARTICLE ACCELERATORS

In most respects, the operational requirements of radiological protection at particle accelerator laboratories do not substantially differ from those at other radiological facilities that have been well documented; for example, in Report 59 of the National Council on Radiological Protection and Measurements (NCRP). Nevertheless, there are aspects unique to particle accelerators that are of concern:

- Facility design,
- Personnel access control,
- Control of radioactive materials,
- Control of contamination, and
- Radioactive-waste management.

These special topics will be discussed in the new version of NCRP Report 51, which is now under revision.

THE FUTURE

Accelerators have entered into the very fabric of our life: they are applied in medicine, materials science and solid-state physics (e.g., ion-implantation);

micro-lithography; food preservation; sterilization of toxic wastes; polymerization of plastics; and radiopharmaceutical production. The applications are many and will increase in the future. Heavy ion accelerators may be used in fusion devices; accelerators will be used to incinerate radioactive waste to produce fissionable material and in plasma heating.

Research instruments now planned or under construction, such as the SSC near Dallas, are of enormous proportions—large enough to encircle a large metropolitan region—and will bring with them other, unanticipated technological spin-offs. In adopting these new technologies, it is to be hoped that society will move to develop cost-effective health standards based upon an assessment of all risks to human health and a proper placing of them in context with radiation risks. This could be a welcome change from our present obsession with the "best available technology" approach, which is not necessarily related to health risks.

These newer high-energy accelerators present two radiological issues of interest: first, the generation of muons (because of their copious production at higher energies), presenting an environmental impact; and second, the production of neutrons and other high-LET radiation. Perhaps, in the last analysis, it will be only high-LET radiations that are of concern at low doses. In the future, accelerators will provide a continuous source of high-LET radiation to which workers and nearby members of the public will be exposed. We will need to understand the radiobiological implications of such exposures and improve on our techniques of measurement to meet this important challenge.

REFERENCES

- Fassò, A., K. Goebel, M. Höfert, J. Ranft, and G. R. Stevenson (1990), *Shielding Against High-Energy Radiation*. (Springer-Verlag, Berlin).
- Goebel, K. (1987), "Radiation Protection for the CERN Large Electron Project LEP," in *Proc. Health Phys. Rad. Generating Machines, 20th Mid-Year Topical Symp.* (Health Physics Society, Reno, Nevada).
- National Council on Radiological Protection and Measurements (1978), *Operational Radiation Safety Program*, Report 59, NCRP, Washington, DC.
- Patterson, H.W., and R. H. Thomas (1973), *Accelerator Health Physics*, (New York, Academic Press).
- Perry, D. R., K. B. Shaw, G. B. Stapleton, G. R. Stevenson, and R. H. Thomas (1991), *Trends in Radiological Protection at High-Energy Accelerator Laboratories*, Rutherford Appleton Laboratory, Report, RAL-91-019, *British Nuc. Conf. Occ. Rad. Protection*, (Guernsey, UK, April 29-May 3, 1991).
- Stapleton, G. B., K. C'Brien, and R. H. Thomas (1991), *Accelerator Skyshine: Tyger, Tyger, Burning Bright*, internal report, Continuous Electron Beam Accelerator Facility, Newport News, VA.
- Stevenson, G. R., and R. H. Thomas (1984), "A Simple Procedure for the Estimation of Neutron Skyshine From Proton Accelerators," *Health Phys.* **42**, 115-222.
- Swanson, W. P. (1979), *Radiological Safety Aspects of the Operation of Electron Linear Accelerators*, AEA Technical Report 188, IAEA, Vienna.
- Swanson, W. P., and R. H. Thomas (1991), "Dosimetry for Radiological Protection at High-Energy Particle Accelerators," in *The Dosimetry of Ionizing Radiation*, Kase, Bjarngard, and Ahix, Eds. (Academic Press, New York).
- Thomas, R. H., and G. R. Stevenson (1988), *Radiological Safety Aspects of the Operation of Proton Accelerators*, AEA Technical Report 283, IAEA, Vienna.
- Thomas, R. H., and A. Rindi (1979), "Radiological Impact of High-Energy Accelerators," *CRC Control Reviews in Environmental Control* **9**(1), pp. 51-95.

RADIATION PROTECTION AT THE CERN LARGE ELECTRON POSITRON
COLLIDER(LEP)

M. Höfert, A. Fassò, K. Goebel, G.R. Stevenson
CERN, Geneva, Switzerland

P. Schmidt
Technical University, Dresden, Germany

ABSTRACT

Results of recent investigations into two particular aspects of radiation protection at LEP are presented: penetration of radiation as a result of beam losses through the main shield and attenuation of low energy photons from synchrotron radiation in ducts and labyrinths.

INTRODUCTION

The Large Electron Positron collider (LEP) is an accelerator where counter rotating beams of electrons and positrons are stored for periods of several hours and collide in four experimental areas. LEP is housed in a circular tunnel with a circumference of approximately 27 km. The collider came into operation in July 1989 and has worked since then at beam energies of 45 GeV. Following the installation of superconducting RF cavities in the near future with the consequent possibility of transferring more power to the beam, the energy will be increased over the next few years to its design value of 100 GeV.

Studies of radiation protection issues in this unique high-energy installation started in 1980. In this paper attention will be primarily concentrated on only two aspects: shielding against beam losses and shielding against the intense synchrotron radiation emitted from the bending sections of the collider.

SHIELDING AGAINST BEAM LOSSES

The amount of shielding necessary around LEP is determined by beam losses either during the filling operation of the storage rings at an injection energy of 20 GeV or by the possibility of a full loss of the stored beams at their maximum energy (100 GeV). CERN's radiation protection philosophy already stipulated in 1981 that annual personal exposures should stay within a reference dose of 15 mSv i.e. below the new dose limits only recently recommended by ICRP^{1,2}. It was decided to design the shielding for LEP such that annual doses in occupied areas would never exceed 10 mSv. Occupancy time would then provide an additional safety factor.

The classical way to treat shielding assessment for electron accelerators is to consider the three main radiation components of the electron-induced shower that develops in the shield separately, i.e. the electromagnetic, the fast neutron and the high-energy particle components. In most materials, due to the short radiation lengths which govern electron-gamma shower development, the effective source for shielding against beam losses can be regarded as point-like so that a $1/r^2$ dependence for the overall attenuation of the radiation will hold.

Furthermore the intensity of stray radiation produced in the interaction of a several GeV electron beam is considered to be proportional to the beam energy. Lateral shielding requirements for each component can then be characterized by two parameters, a source term per interacting electron given in $\text{Sv m}^2 \text{GeV}^{-1}$ and an attenuation length for the shielding material (concrete or earth) in g/cm^2 . These parameters are presented in the following table as they were used in the shielding estimations for the LEP collider³.

Source terms for electron beam losses and radiation lengths in concrete or earth perpendicular to the beam line for the three radiation components as used in the shielding estimations for the LEP collider.

Radiation component	Source term in $\text{Sv m}^2 \text{GeV}^{-1}$ per electron	Attenuation lengths in g/cm^2
Electromagnetic	$2.2 \cdot 10^{-15}$	48
Giant resonance neutrons	$1.0 \cdot 10^{-15}$	42
High energy particles	$1.5 \cdot 10^{-17}$	115

Since LEP was designed, three changes have occurred which will modify the parameters in the table. ICRP has recommended that the radiation weighting factor for fast neutrons should be changed from 10 to 20 in the energy range from 0.1 to 2 MeV^2 . It would therefore be prudent to multiply the source term for the giant resonance neutron component by a factor of two. Recent work has shown that the source term for the high energy component is higher than previously assumed ($4.2 \cdot 10^{-17} \text{Sv m}^2 \text{GeV}^{-1}$) and the attenuation length somewhat lower (100g/cm^2 compared to 115g/cm^2)⁴. These new values are used in figure 1 where the dose equivalent in Sv per electron for the different radiation components is plotted as a function of the lateral thickness of concrete (density 2.4g/cm^2).

Fig. 1: Curves showing the lateral attenuation of the three main radiation components in the case of electron accelerators.

- 1) Electromagnetic component,
- 2) Giant resonance (fast) neutrons and
- 3) High energy particles.

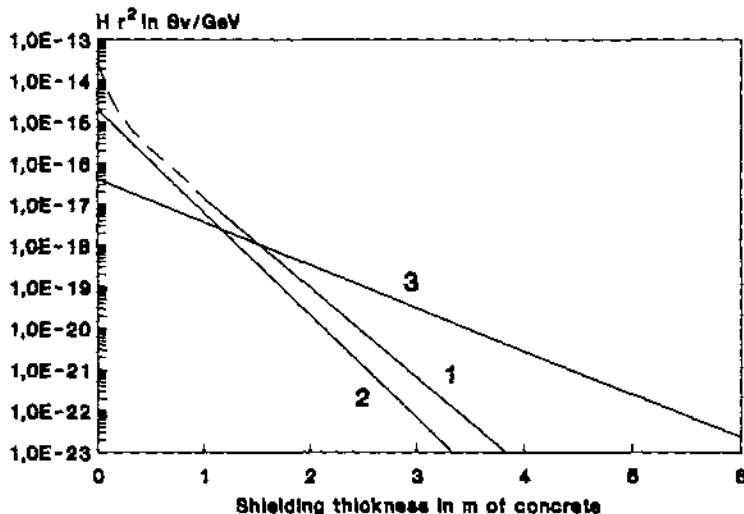

The functions for three components are purely exponential when the geometrical $1/r^2$ dependence for a point source is removed. The parameters that were used in the LEP design give similar answers to those obtained using the more recent parameters since it is only beyond a shielding thickness of about 1.5 metre that the high energy particle component will determine the overall shielding requirements of a GeV electron accelerator. At LEP the required shield thicknesses are in the 1 to 2 metre range and here the effect of the higher source term for the high-energy particle component is compensated by the shorter attenuation length. Hence, for LEP the change of parameters had no effect but since the knowledge of source terms and attenuation lengths is particularly important for a future generation of high intensity machines like CEBAF or CLIC it is essential that extrapolations of earlier measurements and recent calculations be supported by benchmark experiments.

SHIELDING AGAINST SYNCHROTRON RADIATION

Photon energies for synchrotron radiation resulting from the operation of the LEP collider extend from below 1 keV to several 100 keV even reaching energies greater than 1 MeV when the machine will have attained its design energy of 100 GeV. The high photon intensities mean that particular care has been taken in the design of lead shielding around the LEP vacuum chamber in order to protect sensitive equipment in the accelerator tunnel against damage caused by radiation. Correct design of the ducts for cables and access labyrinths for personnel through the main shield in order to limit doses in occupied areas is also essential. The construction of these passage-ways was based on so-called "universal attenuation curves" that had been confirmed by measurements in the case of neutrons⁵.

Fig.2: Universal attenuation curve (solid line) for the second and higher legs in access labyrinths as a function of their cross-section A and their depth d . The dotted lines give the range of uncertainty⁵. The rectangles present results for photon transmission by Morse-calculations and their uncertainties⁶, \diamond the results of measurements in a second leg, Δ the results for a third leg⁷.

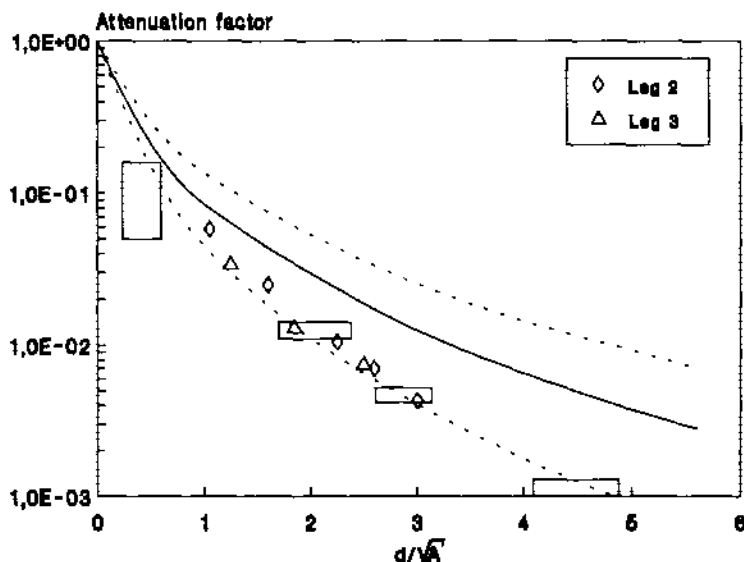

For photons Monte-Carlo simulations suggested that the attenuation of photons in labyrinths would be more important than for neutrons, but these simulations were poorly supported by very few measurements⁶. Hence the labyrinths of LEP were built with a considerable safety factor.

Reliable experimental information for the penetration of synchrotron radiation through ducts and labyrinths in the shielding of LEP became available only recently⁷. The results of the experiment are shown in figure 2 together with results of Monte-Carlo calculations and the universal attenuation curves for the second and higher legs of a labyrinth. For photon radiation the attenuation with depth follows the relation on the lower bound of uncertainty and confirms the earlier results from calculations with the MORSE transport code.

CONCLUSIONS

Up to now radiation protection experience with the operation of LEP has revealed no surprises. Radiation levels in occupied areas are barely measurable in the present mode of operation. It is however expected that radiation levels will increase as beam energies and intensities are increased to their design value. Future developments of the radiation situation will be closely followed in order to compare the predictions made in the design studies (summarized in reference 3) with the results of actual measurements.

REFERENCES

1. CERN, 1981, Radiation Protection Philosophy, in Weekly Bulletin of CERN N^o 29/81.
2. ICRP, 1991, Publication 60, 1990 Recommendations of the International Commission on Radiological Protection, Annals of the ICRP 21, 1.
3. Rapport provisoire de sureté du LEP, CERN, juillet 1987.
4. Fassò, A., Höfert, M. and Ioannidou, A., 1991, On the shielding of electron accelerators in the GeV energy range, Accepted for publication in Rad. Prot. Dosim.
5. Vogt, H. G., 1975, Monte Carlo Calculations of neutron transmission through the access ways of the CERN Super Proton Synchrotron, CERN/LabII/Radiation Group, Rep 75-14.
6. Fassò, A., Stevenson G.R., Tartaglia, R. and Ferrari A., 1987, Monte Carlo simulation of synchrotron radiation transport and calculation of dose to the components of a high-energy accelerator, Prog. in Nucl. Energy, 24, 417.
7. Schmidt, P., 1991, Dosimetry of scattered synchrotron radiation in the LEP environment, CERN/TIS-RP/IR/91-18

PHOTONEUTRON LEAKAGE FROM MEDICAL ACCELERATORS: A COMPREHENSIVE
APPROACH TO PATIENT AND PERSONNEL DOSE MEASUREMENT

F. d'Errico and G. Curzio

Dipartimento di Costruzioni Meccaniche e Nucleari
Università degli Studi di Pisa
Pisa, ITALY

ABSTRACT

Simple and reliable techniques, based on the use of superheated drop neutron detectors (SDD's*), are presented for both medical accelerator personnel exposure monitoring, and the direct measurement of non therapeutic dose equivalent received by patients undergoing high-energy x-ray and electron treatment.

INTRODUCTION

Radiotherapy by means of high energy bremsstrahlung allows for a well established advantage over Cobalt-60 therapy: the treatment of a target volume with minimum dose deposition in surrounding healthy tissues.¹ Unfortunately, nuclear interactions between such radiation and the medium- to high- atomic number constituents of the accelerator head, treatment room and patients themselves, yield fast neutrons causing further undue exposure.

The assessment of dose equivalent from these photoneutrons is among the most complex tasks in mixed field dosimetry: the x-ray field is extremely intense, photons exceed the neutron fluence by factors of 1000-4000 inside the collimated beam, and 10-100 outside; neutron energies are mostly in the 100 keV to 2 MeV range, over which the dose equivalent per unit fluence varies by a factor of three; finally, the pulsed nature of the radiation field overwhelms the counting electronics of any active detector.²

Passive neutron rem-meters provide the simplest way to measure ambient dose equivalent, the regulatory quantity of interest, which should be monitored periodically, since neutron leakage appears to vary with machine age and state of adjustment.³ The main advantage of rem-meters is that they are insensitive to the neutron spectral shape, restrictions on their applicability derive from their large dimensions and directional response. In an attempt to overcome the above mentioned shortcomings, a new approach based on SDD's has been developed.^{4,5}

MATERIALS AND METHODS

The SDD is a suspension of superheated halocarbon drops dispersed in a nearly tissue equivalent gel. High LET neutron recoils trigger the boiling of these drops, nucleating visible bubbles. The total volume of vapor or the pressure pulses

* SDD is a trademark of Apfel Enterprises, Inc., New Haven, CT.

accompanying each nucleation event may be registered and give a measure of neutron irradiation.

While virtually insensitive to photons up to 15-18 MeV, the SDD detects neutrons with a free-in-air energy response that, above 50 keV, resembles fluence-to-ambient-dose-equivalent as well as kcrma-equivalent (ideal response for an in phantom rem-meter) conversion factors.⁶ The agreement between albedo response and individual dose equivalent (penetrating) per unit fluence is even closer.⁷

Based upon these considerations, we devised the application of SDD's in personal, ambient and depth- dosimetry around medical accelerators. In particular, a passive, integrating rem-meter of 2 cm³ active volume and isotropic response was realised by simply screwing a graduated pipette onto the detector vial. Vapor bubbles displace an equivalent volume of gel into the pipette (Figure 1), providing an immediate reading of the neutron dose equivalent field inside and outside x-ray treatment beams.



Figure 1. Passive, integrating, instant read-out neutron detector.

Furthermore, these devices are tissue equivalent (Table 1), and can be placed inside phantoms without affecting neutron spectrum and charged particle equilibrium.

Table 1. Physical properties of TE composition recommended by ICRU Rep. 33, our phantom, and superheated drop detector.

Material	Per cent elemental weight					Density (g cm ⁻³)
	H	C	O	N	Other	
ICRU 33 TE	10.1	11.1	76.2	2.6	-	1
TE liquid	10.2	11.1	76.1	2.6	-	1.07
SDD	8.8	28.2	62.5	-	0.18 F, 0.32 Cl	1.25

Employing sets of previously calibrated detectors, we acquired free-in-air and entrance dose equivalent profiles for various 18 MV x-ray beam sizes of a Saturne 20 accelerator. Entrance dose was measured at an average depth of 1 cm inside a 20x30x80 cm³ TE phantom (Figure 2).

RESULTS

The results of our measurements are summarized in Figure 3. For each beam size, dose values are normalized to x-ray dose at maximum build-up at the isocenter. The error bars overestimate optical misreading of the graduated pipettes.

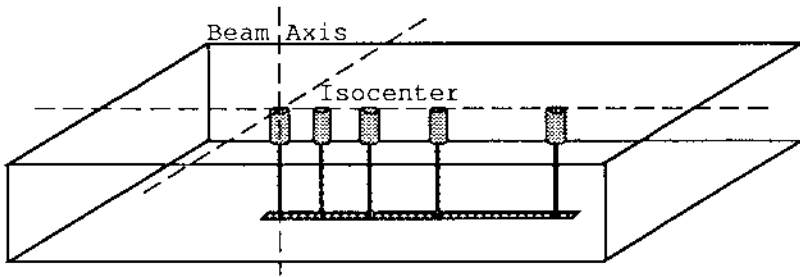

Figure 2. In-phantom irradiation scheme.

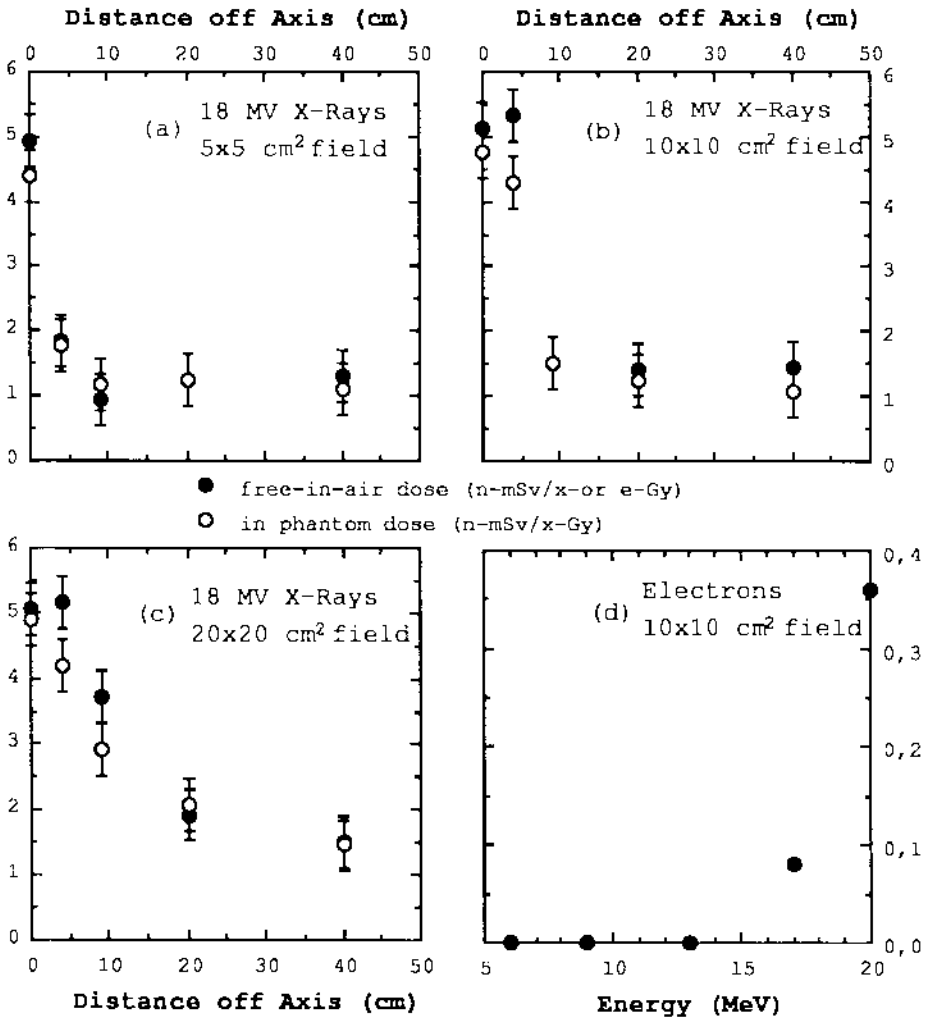

Figure 3. (a, b, c) Neutron dose equivalent profiles for some x-ray fields. (d) Neutron dose equivalent at the isocenter of 6-20 MeV electron beams.

Our measurements show that free-in-air dose is slightly higher than entrance dose, and confirm that the contribution from photo-neutrons generated inside the patient is negligible, as asserted by several authors. Also, the neutron source strength at the x-ray beam isocenter appears to be substantially independent of beam size. These results are in good agreement with the preliminary indications of an on-going intercomparison with CR-39 detectors.

CONCLUSIONS

The mixed field dosimetry method presented here allows for an immediate evaluation of photoneutron leakage from medical accelerators, without any detector post-processing subject to operator error. The integral dose delivered to the patient outside the treatment volume may be easily assessed from the dose equivalent profiles.

REFERENCES

- 1 Nath, R., Laughlin, J.S., Swanson, W.P., and Bond, V.P., 1984, Neutrons from High-Energy X-Ray Medical Accelerators: An Estimate of Risk to the Radiotherapy Patient, *Med. Phys.*, 11, pp. 231-241.
- 2 NCRP, 1984, Neutron Contaminations from Medical Electron Accelerators, Report 79, Washington D.C.
- 3 Sherwin, A.G., Pearson, A.J., Richards, D.J., and O'Hagan, J.B., 1988, Measurements of Neutrons from High Energy Electron Linear Accelerators, *Radiat. Prot. Dosim.*, 23, pp. 337-340.
- 4 Nath, R., Meigooni, A.S., King, C., and d'Errico, F., 1990, Superheated Drop Detectors for Determination of Neutron Dose Equivalent to Patients Undergoing High-Energy X-Ray and Electron Radiotherapy, *Med. Phys.*, 3.
- 5 Apfel, R.E., Characterization of New Passive Superheated Drop (Bubble) Dosimeters, Proceedings of the VII Symposium on Neutron Dosimetry, Berlin, 14-18 October 1991.
- 6 d'Errico, F., and Apfel R.E., 1990, A New Method for Neutron Depth Dosimetry with the Superheated Drop Detector, *Radiat. Prot. Dosim.*, 30, pp.101-106.
- 7 Curzio, G., and d'Errico, F., Rivelatori a bolle per la dosimetria neutronica, Proceedings of the XXVII Congresso Nazionale dell'AIIRP, Ferrara, 16-18 September 1991.

ACKNOWLEDGEMENTS

We would like to thank Dr Ciucci from our Department, Dr Tana from Ospedale Santa Chiara, Pisa, and Dr Civolani from ENEA, Bologna, for their valuable cooperation.

EMPLOYEE DOSE REDUCTION AT BRITISH NUCLEAR FUELS plc

A.H. Fishwick, J.L. Finlayson and R.D. James

British Nuclear Fuels plc
Risley, Warrington, Cheshire, U.K.

ABSTRACT

Average workforce doses in uranium fuel fabrication plants are a small percentage (about 6% or 3 mSv pa) of UK regulatory limits. In uranium metal casting, and uranium oxide production plants, doses are somewhat higher than the average. Dose reduction methods have, however, resulted in these being reduced to 20%, or less, of the same limit. Major future investment should reduce doses in oxide production plants to about the current average level.

INTRODUCTION

British Nuclear Fuels plc (BNFL) sets stringent Company targets for employee dose uptake and, in addition, has always vigorously employed the principle of ALARP. Thus, the current design targets for new plant are 5 mSv per calendar year (average) and 15 mSv per calendar year (maximum individual). For existing operational plants, the relevant targets are 20 mSv per calendar year (maximum individual) and 75 mSv maximum individual over any five consecutive years. All targets are the sum of effective dose equivalent and committed effective dose equivalent. These targets are the outcome of a response to a growing emphasis on the application of ALARP since 1975 and, more recently to the added impetus provided by the "Gardner Report" (Ref 1) and ICRP 60.

Employee dose reduction at the Sellafield reprocessing plant has been the subject of previous papers (Refs 2 and 3). This paper describes trends in dose reduction, and methods of achieving that, at the Springfields nuclear fuel fabrication plant, from 1986 to 1991.

DOSE REDUCTION TRENDS

By comparison with the above targets, average doses at Springfields have always been low (Table 1).

TABLE 1

Average Whole Body, and Collective Doses
(all Classified Workers)

<u>Year</u>	<u>Average Dose</u> <u>(mSv)</u>	<u>Collective Dose</u> <u>(manSv)</u>
1986	4.0	12.6
1987	3.8	11.9
1988	2.4	7.0
1989	2.6	7.0
1990	3.1	7.4
1991 (projected)	2.5	6.0

The slight increase in 1990 was a result of some increase in programme with a workforce strength at about 75% of the 1986 figure. Further emphasis on ALARP has since reversed this trend.

Against this background, dose reduction policies and practices have been focused primarily on reducing dose in areas of the plant where these have been highest by comparison with the above averages. The two areas receiving the greatest attention have been the Uranium Casting Plant and the Oxide Powder and Pelleting Plants. Springfields is a multi-purpose Site, providing a wide range of finished fuels and intermediate products. It incorporates major production lines for the fabrication of metal fuel for Magnox reactors and Oxide fuel for AGR and PWR reactors. The Casting Plant is one of the stages in the production of Magnox fuel.

Recognising the eventual termination of the UK Magnox programme, major capital investment in new plant to service this programme could not be justified. Therefore, the casting, and other, stages of the fuel fabrication process have undergone extensive refurbishment of which dose reduction has been a significant, but not the only, feature. The cost of the casting renovation project was £2.5M (1981 MV) ie £4.5M (1991 MV). New, and modified, equipment and procedures were installed to bring about reduction in both internal and external doses.

For Oxide fuel production, the situation is different. In the UO_2 Powder Production plant, extensive modifications to existing cubicalised plant items had been carried out progressively from the mid 1970s to the mid 1980s (total cost in 1991 MV, £0.9M). Improved ventilation of, and operator access to, the cubicles, together with other engineered features, had resulted in significant reduction in airborne contamination levels in the working areas. Following this, nothing further by way of major renovation of existing facilities was practicable. Similar, though less extensive, work was carried out in the UO_2 Pellet

Plant. However, future potential Oxide fuel business, in both UK and worldwide, has justified investment (£145M, 1991 MV) in a major new plant, the New Oxide Fuel Complex (NOFC) to completely replace all existing Oxide production facilities and allow continuation, and expansion, of this side of the business into the 21st century. NOFC is currently under construction and will come on line, in phases, from 1994. Again, dose reduction is a prominent design feature. In the meantime, existing plants have continued to operate at high proportions of capacity but, by attention to good housekeeping and making modifications to reduce dose wherever reasonably practicable, doses have been steadily driven down (Table 2).

TABLE 2

Whole Body Doses, Casting and Oxide Plants

<u>Year</u>	<u>Casting</u>		<u>Oxide Powder</u>		<u>Oxide Pelleting</u>	
	<u>Ave Dose (mSv)</u>	<u>No. > than 15 mSv</u>	<u>Ave Dose (mSv)</u>	<u>No. > than 15 mSv</u>	<u>Ave Dose (mSv)</u>	<u>No. > than 15 mSv</u>
1986	18.8	35	13.9	33	11.3	12
1987	17.2	32	9.6	NIL	7.9	NIL
1988	13.4	10	8.8	NIL	5.6	NIL
1989	8.5	1	8.2	NIL	6.3	NIL
1990	6.6	NIL	10.6	NIL	7.9	NIL
1991 (projected)	3.3	NIL	8.0	NIL	6.3	NIL

In addition to average dose, the other important indicator of the dose uptake position is the number of workers whose dose exceeds the UK Ionising Radiations Regulations investigational level of 15 mSv per calendar year. This number, also, has been reduced from the mid 1980s figure to a position in which there are now no such cases.

THE FUTURE

NOFC has, of course, been designed to meet Company dose targets. In practice, it is assessed that actual doses will be well below target (about 3 mSv pa or less as an average) due, mainly, to sophisticated methods of containment of any airborne UO₂ powder, internal dose uptake being the dominant potential factor in Oxide plants. In other areas, the now well established Joint (Management/Workforce) Dose Reduction Working Parties will continue to identify dose reduction methods for implementation wherever they can be justified on ALARP grounds. These Working Parties now operate throughout the Works including areas where dose has always been very low, with the objective of reducing doses still further wherever reasonably practicable.

CONCLUSION

Average, and maximum, doses at Springfields Works are well within Company targets which, themselves, are well within regulatory requirements. Future developments will continue to drive doses down to levels that are significantly below ICRP 60 recommendations.

REFERENCES

1. Gardner, M.J. et al. Results of a case control study of leukaemia and lymphoma among young people near Sellafield Nuclear Plant in West Cumbria. British Medical Journal Vol 300 pages 423-429, February 1990.
2. Dose reduction and the application of the ALARP principle to occupational exposure at the nuclear fuel reprocessing plant at Sellafield in Cumbria. R.W. Anderson and R. Coates, Occupational Radiation Protection, BNES Guernsey, 1991.
3. Past trends in occupational exposure in nuclear fuel reprocessing at Sellafield, R. Strong and C. Partington, Occupational Radiation Protection, BNES Guernsey, 1991.

DOSE AND DOSE RATE MEASUREMENTS AROUND THE SIS

J. G. Festag

Gesellschaft fuer Schwerionenforschung mbH, Darmstadt,
Federal Republic of Germany

ABSTRACT

Dose equivalent measurements with a TEPC and a modified rem counter around a heavy ion accelerator are reported. These measurements give some informations about the composition of the radiation field.

INTRODUCTION

A heavy ion synchrotron (SIS) is operated by the GSI at Darmstadt, Germany. The highest attainable specific energy of 2 GeV/n for carbon descends to about 1 GeV/n for uranium. Till now ions from neon to bismuth have been accelerated with up to 10^9 particles per spill. The length of the interval between two successive spills depends on the extraction mode, but this time is usually longer than 1 second at the moment.

EXPERIMENTAL MEASUREMENTS

Dose and dose rate measurements were made by a TEPC, type HANDE (1), and a high pressure ionization chamber (7 bar, Ne/Ar mixture), type FAG FHT 191 N, in regions with thin and thick shielding. The dose equivalent is calculated from the energy dose by using the ICRP 21.

Behind thick shielding (more than 400 g/cm² concrete) the TEPC gives a quality factor near to 4 (3,94). Such a value is known from other high energy accelerators (2). Distributions of the lineal energy are shown in figure 1a. The contribution of the neutrons to the dose equivalent appears in the higher lineal energies.

Measurements with ⁶LiF TLD's in a 12 inch polyethylene moderator give also a quality factor of 4. Here the calibration was made with neutrons coming out of an Am-Be source.

In regions with a thin or almost no shielding the quality factor varies depending on the degradation of the primary beam. The figures 1b and 1c show two examples. ¹⁹⁷Au ions of 814 MeV/n are stopped in carbon surrounded by concrete (less than 300 g/cm²); the secondary high energy particles deposit only a little energy in the detector (figure 1b); the Q - value is 2.1. Figure 1c shows the frequency distribution of the lineal energy registered by the TEPC during stopping and focussing of an ¹⁹⁷Au ion beam with a specific energy of 1 GeV/n. This distribution is very similar to that measured behind thick shielding (figure 1a) and indeed here the quality factor is also near to 4 (3.99).

For comparison a frequency distribution of the lineal energy of a background measurement with $Q = 2.2$ is shown in figure 1d.

The energy doses (Gy) registered by the TEPC and by the ionization chamber are very similar.

The measurements were made for times of several hours during the normal course of nuclear physics experiments, therefore relations between the dose rate and the ion current of the beam cannot be given because the intensity of the beam was not held constant.

Activation techniques for the evaluation of the neutron energy spectrum could not be applied on behalf of too low intensities.

Birattari et al. (3) have described an extended range neutron rem counter, which shall be able to measure neutrons with energies up to about 400 MeV with an adequate sensitivity.

An unmodified rem counter and a rem counter surrounded by a layer of 2 cm lead were used to look for neutrons with energies above 20 MeV. The measurements were taken behind thick shielding. The results are given in the following table.

accelerated ions	ion energy	measured dose equivalent by the unmodified rem counter	(dose equivalent measured by the rem counter with lead) divided by (dose equivalent of the unmodified rem counter)
	MeV/n	μSv	
^{20}Ne	310 - 400	6.7	1.71 ± 0.03
^{20}Ne	400	0.3	1.84 ± 0.61
^{209}Bi	800	1.1	1.65 ± 0.08

The given uncertainties of the result take only into account the standard deviation of the registered counts.

CONCLUSIONS

The results are preliminary, but at this stage they point out that a not negligible share of the dose equivalent is caused by neutrons with energies of more than 10 Mev.

REFERENCES

1. Dietze, G. et al., 1988, Investigation of radiation protection instruments based on tissue - equivalent proportional counters. Results of a EURADOS intercomparison, EUR 11867 EN.
2. Hoefert, M. et al., 1980. Nucl. Instr. and Meth. 176, pp. 443-448.
3. Birattari, C. et al., 1990. Nucl. Instr. and Meth. A297, pp. 250-257.

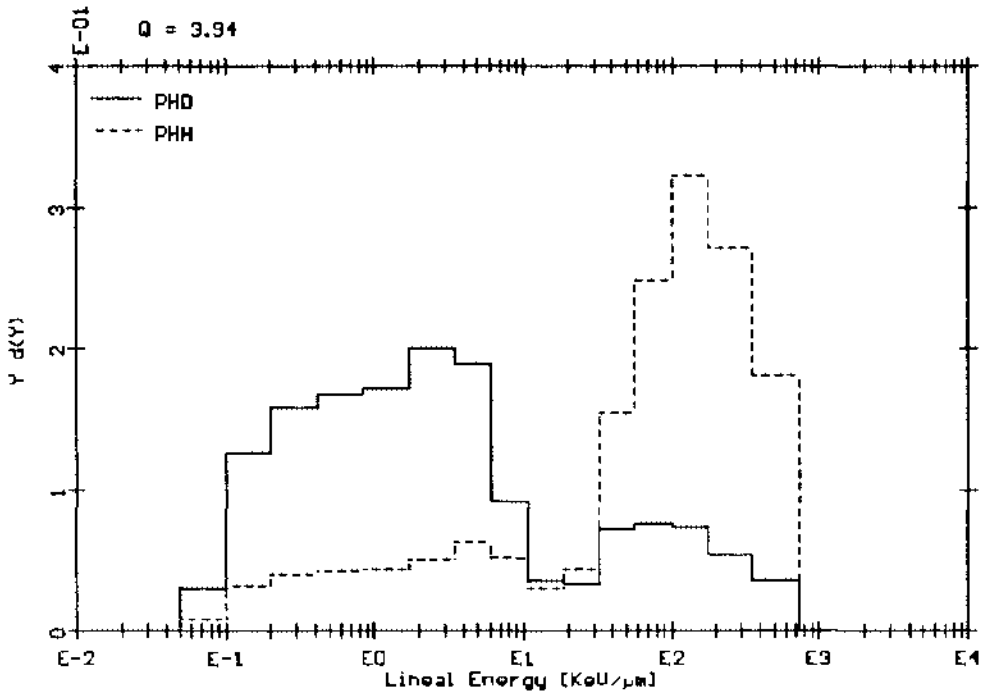

figure 1a

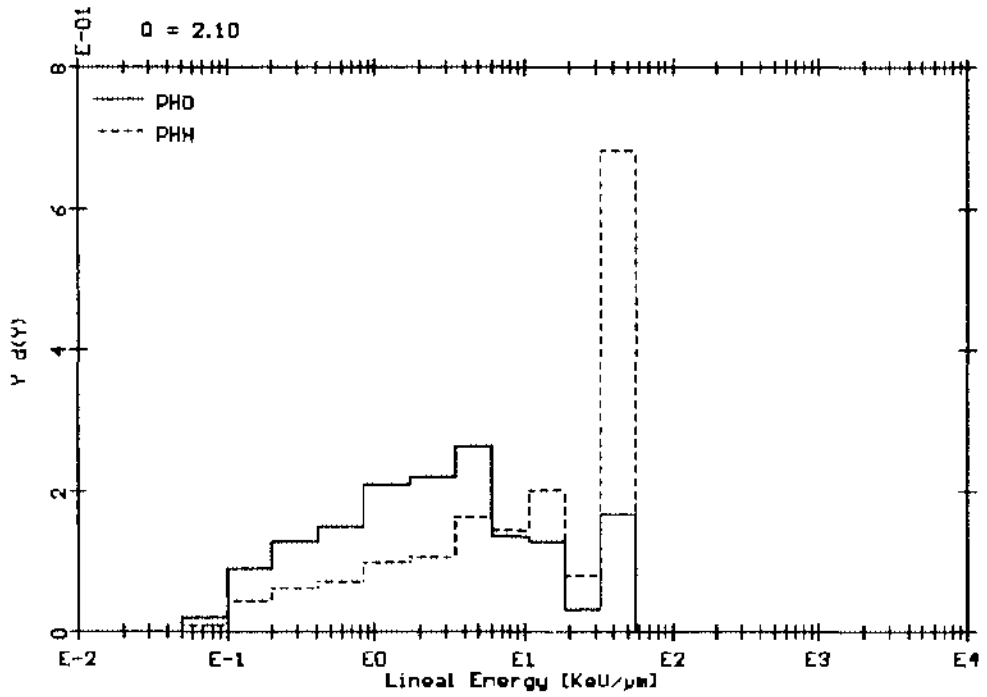

figure 1b

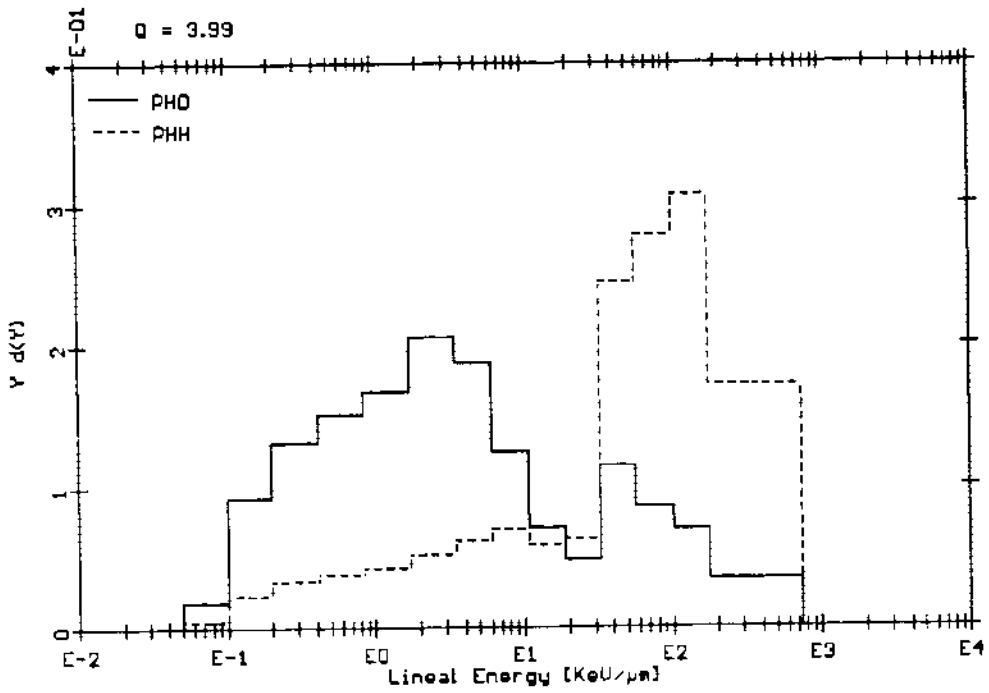

figure 1c

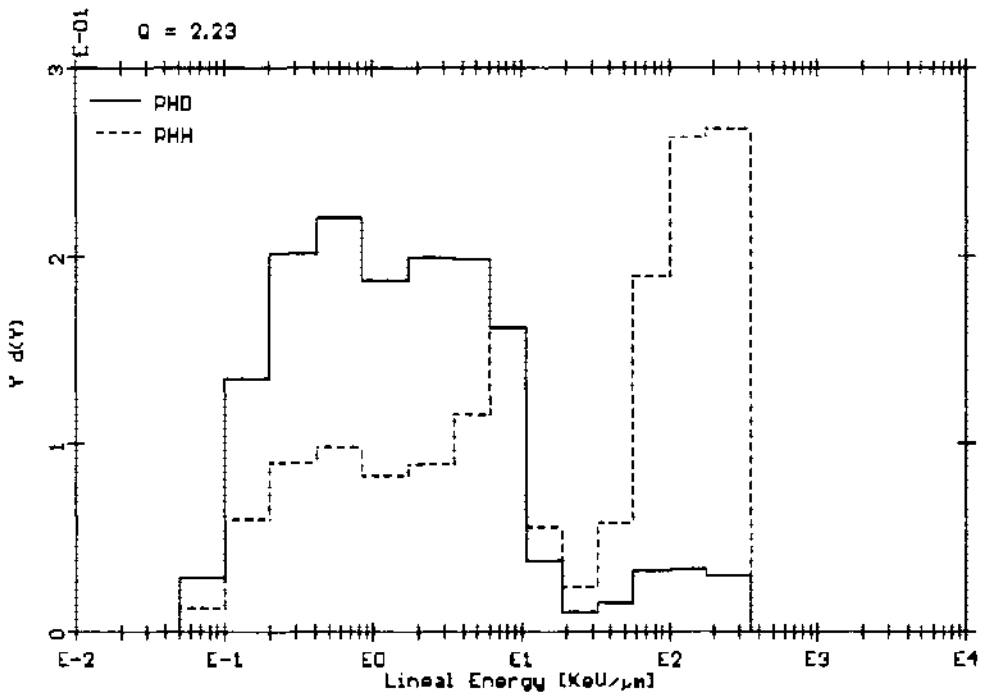

figure 1d

CONTAMINATION BY TRITIUM OF WATERS AND CONCRETE
IN A RESEARCH REACTOR CONTAINMENT DUE TO LEAKAGE OF HEAVY WATER

Masami Fukui

Radiation Control Division,
Research Reactor Institute, Kyoto University,
Kumatori-cho, Sennan-gun, Osaka(590-04), Japan

ABSTRACT

Approximately heavy water of ca. 28.2 L (ca. 0.34 TBq of tritium) leaked from the D₂O facility of the Kyoto University Reactor (KUR) during the period of about one and half year. As a result of the incident, HTO concentrations in pool waters had increased extensively as well as in the containment building air during the period before the leak detection. The soaking effect of HTO vapor by the building concrete was also confirmed by air monitoring. Although the leak was of little radiological consequence, it served as a useful lesson of our emergency response.

INTRODUCTION

Radiation protection both on and off the site is deeply dependent upon the availability of appropriate monitoring data both in nuclear facilities and in natural environs.

The KUR near Osaka, Japan commenced operation in 1964 at 1 MW_{th} but the power was raised to 5 MW_{th} in 1968. Ventilation system in the containment building works so as to cover the duration of the reactor operation cycle of 70-80 h/wk. By the routine monitoring the concentrations of radionuclides in the exhaust air from the KUR, operating at 5 MW_{th} have been confirmed to be in the order of 10⁻² Bq/cm³ for ⁴¹Ar, 10⁻⁶ Bq/cm³ for HTO, 10⁻⁸ Bq/cm³ for ¹³³I and 10⁻⁹ Bq/cm³ for ¹³¹I. Because of the low detection limits, as measured by a 22-L ionization chamber set for the exhaust streams, the presence of most radionuclides in the stream is usually masked by the reading of ⁴¹Ar for such minor releases during normal operation of the reactor; this is especially true for HTO vapor. For this reason, monitoring of HTO vapor in the exhaust is carried out during the operation of the KUR on twice a year basis using liquid scintillation counting of water samples collected by condensation from the exhaust air.

BACKGROUND TO THE INCIDENT

During such a routine check in fall 1987, a relatively high concentration of HTO vapor was detected in the condensate. This result, however, was attributed to probable contamination of experimental devices because the same staff of the Radiation Control Division was involved in the research of tritium metabolism and routine monitoring of HTO from the KUR stack. A water sample was not taken from the exhaust during the next monitoring period (Spring 1988) because the operation of KUR was suspended over a 3 month period beginning in April because of fixation for secondary

coolant system. Although passing over data from the exhaust air monitoring had delayed the confirmation of HTO leakage, there was another indicator of leakage. The source monitoring data obtained by the Research Reactor Division had showed gradual increases in the HTO concentration in pool water in the containment building. This was especially the case in the sub-pool (ca. $1.0 \text{ m}^2 \times 1.7 \text{ m}$ deep), located on the top of biological shield, where the HTO concentration in water had increased 60-fold during the period of 1 y (May 1987-April 1988). Investigations into the source of this increase in the HTO concentration in water were focused mainly on the presence of irradiated materials such as lithium and boron which could be a source of HTO production by a neutron activation process. A smear test carried out on August 1988 revealed significant contamination on the front surface of a heavy water tank, and a high HTO concentration was detected in the atmosphere near the D_2O tank using a 1.5-L portable ionization chamber. These findings led to the conclusion that HTO increases in water were the result of leakage of the heavy water. Nevertheless, the mechanisms by which HTO concentrations of both the sub-pool and the primary coolant water (about 30 m^3 and 9-m deep) had extensively increased during 1 year since May 1987, were unknown.

SURVEY OF LEAK POINT AND RECOVERY OF HTO

Under normal conditions, the aluminium D_2O tank contains approximately 2.2 m^3 of heavy water with a purity of 99.7%. As is shown in Fig.1, one face of the D_2O tank, ca.1.8 m in dia., is adjacent to a graphite block layer (ca. 1.5 m^3), 48 cm thick, with a bismuth plug. The space in front of this layer is used as an irradiation room with dimensions ca. $2.4 \text{ m} \times 2.4 \text{ m} \times 2.4 \text{ m}$, covered with high density concrete identical to the biological shield of the reactor core. By 5 October 1988, the concentration of HTO in condensate in air near the tank was found to be as much as 2.2 MBq/ml . Then, using an air conditioner and a 20-L water bubbling trap, a 6-wk program was started to lower the moisture in the air in the irradiation room adjacent to graphite blocks. On 16-17 November, the heavy water in the D_2O tank was withdrawn into 200 L drums and replaced by light water to carry out a leak test. An estimated loss of 28.2 L of heavy water was made by comparing the weight of the water removed with that initially loaded into the D_2O tank. Inspection with a remote TV camera failed to locate the source of the leak in any of the suspected areas such as joints or flanges in the D_2O plumbing system. Then, the high density concrete shield of the irradiation room was dismantled on 21 November 1988. The graphite layer adjacent to the D_2O tank was removed and stored in a container ($2 \text{ m}^2 \times 2 \text{ m}$ in height) on 19 January 1989 so as to access more easily to the tank and to recover any HTO absorbed by the graphite blocks. In early February, air, heated to $90 \text{ }^\circ\text{C}$ was circulated through this container with electrical condensation loop system over a 2-mo period. By this procedure ca. $4.6 \times 10^1 \text{ GBq}$ (ca. 12.4 L of condensate) of HTO was recovered as shown in Fig.2.

On 25 January 1989, less than 100 mL of water was found in a guide tube in the D_2O tank used to hold a thermo-couple. The HTO

concentration of this water was 7.9 MBq/ml, which was close to that of the stagnant heavy water (8.1 MBq/ml) in the dead space of the D₂O plumbing system, and two thirds the concentration of the heavy water in the D₂O tank itself (1.2×10^1 MBq/ml). Therefore, the source of the HTO leak was located somewhere in the guide tube. This tube was cut on the upper part of the tank where it had been inserted, and the resulting hole was welded shut. This resulted in the isolation and sealing of the main sources of HTO in the reactor containment building by early April 1989.

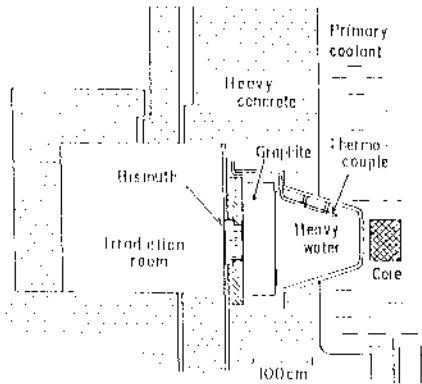

Fig. 1 Cross section of KUR.

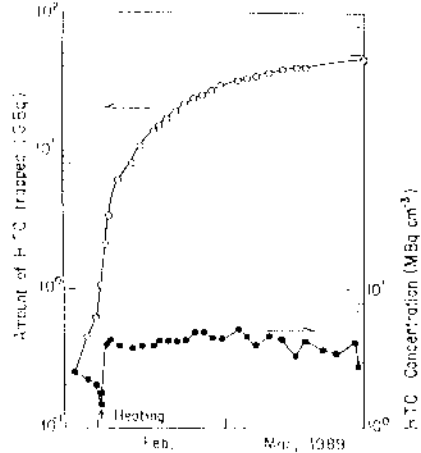

Fig. 2 Amount of HTO recovered.

CHANGE IN HTO CONCENTRATION IN AIR

After the ventilation was shut down, the concentration of HTO vapor in air increased and reached a steady state condition within a few days. Assuming a constant production rate of HTO vapor from sources such as building concrete and neglecting physical decay process of tritium, the growth of HTO concentration in containment building air is formulated as follows:

$$d(CV)/dt = P - \mu CV \quad \dots (1)$$

where

- C : HTO vapor concentration in air (Bq/cm³),
- V : volume of the containment building (cm³),
- P : production rate (Bq/h),
- μ : leak rate (1/h), and
- t : elapsed time after turning off of ventilation (h).

Setting C=0 at t=0, the HTO concentration is given by:

$$C/C_0 = 1 - \exp(-\mu t) \quad \dots (2)$$

where

- C₀ : HTO concentration in air (=P/μV) under steady state condition (Bq/cm³).

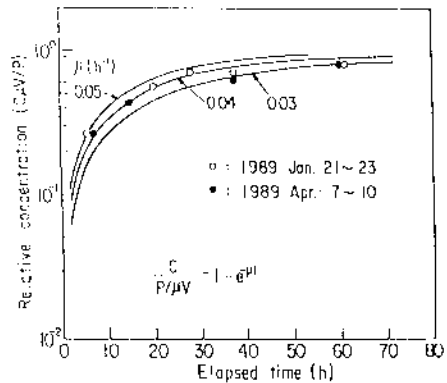

Fig. 3 Growth of HTO concentration in building air.

The growth curve, as expressed by eqn (2) for HTO concentrations in air during shut down of the ventilation allows for the estimation of the leak rate, which was approximately estimated to be 0.04 h^{-1} by the curve fitting as shown in Fig.3.

The production rate, P, could be approximated from eqn (1) as the product, $\mu C_0 V$, for large times ($t > 3 \text{ d}$). Therefore, long-term monitoring of HTO concentration in air (C_0) under steady state conditions allows for the estimation of the attenuation rate of the HTO production rate, which depends on the HTO content in the building concrete. The concentration, C_0 , in air monitored over nearly a 1-y period after venting shut down, shows attenuation rate of approximately $5.0 \times 10^{-3} \text{ d}^{-1}$ ($T_{1/2} = 20 \text{ wk}$) for the first 8-month starting on late November 1988 after transferring heavy water into drums and $3.0 \times 10^{-3} \text{ d}^{-1}$ ($T_{1/2} = 33 \text{ wk}$) since August 1989.

CHANGE IN HTO CONCENTRATION IN POOL WATERS

Laboratory experiments revealed that the fundamental mechanisms describing the HTO dynamics between water and air are exchange and evaporation. A model developed on the basis of this concept gave an average concentration of HTO vapor in air as soaking effect during the period for the HTO concentration in water to decrease from C_{w0} to C_w as expressed in eqn (3),

$$C_v = aH\varepsilon k_c^{-1} \{C_w - C_{w0} \exp(-at)\} / \{1 - \exp(-at)\} \quad (3)$$

where k_c : exchange rate constant between air and water (cm/h),
 k_e : evaporation rate constant (cm/h),
 H : water depth (cm),
 a : $(k_c + k_e)/H$ (1/h),
 ε : isotopic ratio in HTO vapor and water (-),
 C_{w0} : HTO concentration in water at time 0 (unit/ml),
 C_w : HTO concentration in water at time t (unit/ml), and
 C_v : average HTO vapor concentration in condensate in air (unit/ml).

A linear regression for the attenuation of HTO concentrations observed in sub-pool water after removing sources in containment building gave a half-life of approximately 15 wk. Using a value for ε of 0.92 in eqn (3), the average concentration, C_v , in the condensate in the containment building air was calculated to be 36 Bq/ml during 50 wk starting on 20 March 1989. The average value estimated for the air corresponds to only ca. 5×10^{-5} times of the Administrative Level for radiation workers ($7 \times 10^{-1} \text{ Bq/cm}^3$), though it was more than ca. one order larger in magnitude compared with that during normal operation.

CONCLUSIONS

Approximately 0.34 TBq of tritium had been leaked from the D_2O tank over a 19-mo period. More than 80% of HTO leaked was estimated to be released promptly as exhaust. Part of HTO leaked (ca. 2.5 GBq) moved into pool waters via air and increased the concentration as much as ca. 60-fold for sub-pool (1.7 m^3) and 5-fold for primary coolant (30 m^3), respectively. A significant amount of HTO vapor had been absorbed by the concrete material (4.2 GBq) and 46 GBq of HTO absorbed by graphite blocks was recovered.

REDUCTION OF EXPOSURES ARISING DURING THE
MANUFACTURE AND DISTRIBUTION OF RADIOACTIVE
PRODUCTS FOR HEALTHCARE, RESEARCH AND INDUSTRY

R W Davies

Amersham International plc
Amersham Place, Little Chalfont
Buckinghamshire, HP7 9NA
England.

ABSTRACT

Radiation dose uptake for workers in a company producing radioactive materials for use in medicine, research and industry is reviewed. The measures that were introduced to optimise protection are detailed and shown to lead to a 90% reduction in the numbers of workers receiving in excess of 15 mSv in the past four years.

INTRODUCTION

Amersham International specialises in the development, manufacture and distribution of radioactive products for use in healthcare, life sciences research, environmental safety and industrial quality assurance. The production and distribution of the radioactive materials give rise to a number of challenges in radiological protection. These include operation and maintenance of cyclotrons for the production of short lived diagnostic products (containing for example Tl-201, Ga-67, In-111) for nuclear medicine; the design and operation of shielded plant for high energy gamma emitting nuclides used in cancer therapy (eg. Co-60, Cs-137); the preparation for transport of more than $\frac{1}{2}$ million radioactive packages annually.

SAFETY POLICY

The company has had a continuing policy of working to reduce radiation exposure to staff and has set company whole body dose limits below those required by legislation as a means of promoting dose reduction. The success of this policy is evidenced by Figure 1. which shows the progressive reduction in the percentage of the UK workforce receiving doses in excess of 15 mSv over the past 15 years to 0.3% in 1990.

Amersham's focus on safety and dose reduction obtained further impetus with the Ionising Radiation Regulations 1985 (IRR) in the UK, and the introduction of formally recorded reviews of working practices and processes for staff who exceeded 15 mSv.

ANALYSIS OF DOSE REDUCTION

Figure 2 shows the collective dose (man-mSv) and number of staff over the period immediately before and after the introduction of the IRRs. Figure 3 shows the numbers of staff receiving more than 15 mSv over the same period. It is evident that the reduction in numbers of staff exceeding 15 mSv was a result of genuine dose reduction since it was accompanied by a reduction in the collective dose. Figure 4 gives a breakdown of the numbers of staff exceeding 15 mSv since 1986 by work activity.

RADIATION SOURCE PRODUCTION

The main reduction achieved in radiation source production areas followed reviews of working practices which developed increased operator awareness. Line management commitment to dose control encouraged the workers to improve techniques; reduce waste arisings, decrease occupancy times and improve general housekeeping. On older plant, use was made of improved local shielding at critical stages of the processes while new plant was designed and built. The majority of the staff receiving greater than 15 mSv in 1990 were working on old plant which is scheduled for replacement in the next 2 years.

CYCLOTRON OPERATIONS

The very nature of cyclotron operations presents unique radiological problems. Cyclotron produced isotopes typically have half lives of the order of 3 days and thus must be produced several days a week, every week to meet the needs of hospitals. Staff outside the heavily shielded machine vaults only receive background levels of radiation. Maintenance of the machine and any other in-vault work, however, give rise to the potential for high doses from highly activated components.

Machine reliability will always have an overriding effect on operator doses so at Amersham, machine components requiring regular, frequent changing, have been designed to facilitate quicker, simpler maintenance. Component failures have been analyzed to attempt to eliminate them. Changes to machine operating schedules, whilst remaining aligned with customer requirements, have maximised the decay of the shorter lived activation of the vault and the machine components. The combined effect of the actions has been to keep all cyclotron staff doses below 15 mSv in 1990.

TRANSPORT

Introduction of new plant to handle and package certain products (eg Technetium generators), along with major refurbishment of the despatch warehouse area has resulted in significant reductions in operator doses. The material flow pattern through the warehouse has been improved and items requiring manipulation or further work in the warehouse are stored in shielded interim storage facilities. The build up of packages on conveyor lines is prevented to reduce ambient dose rates and the conveyor lines themselves are run, where possible, at high level to increase distance between packages and staff. Increased staff awareness coupled with use of gamma integrating dosimeters has had a positive effect on dose reduction.

The numbers of staff exceeding 15 mSv in other work areas also decreased as a result of similar actions to those outlined above.

CONCLUSIONS

Line management commitment with Health Physics support led to a heightened awareness of dose control measures which encouraged individuals to review and improve their own work method. Investment in personal dosimeters, plant modification and new facilities provided the necessary resource to support the dose reduction initiatives.

Figure 1: Percentage of Workers > 15 mSv
1975 - 1990

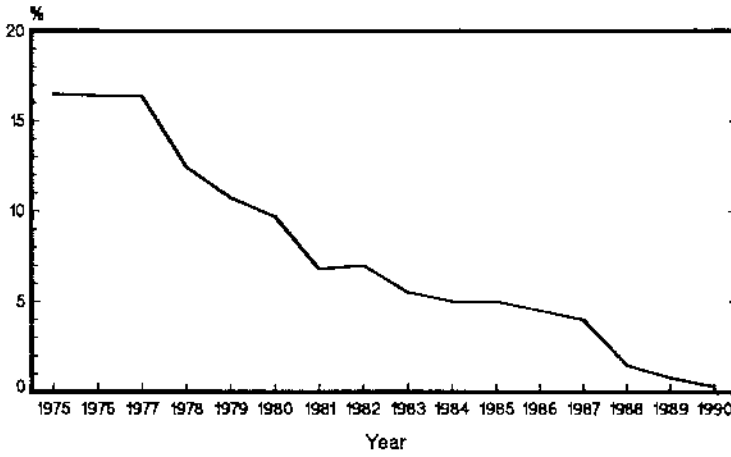

Figure 2: Collective dose / Staff numbers

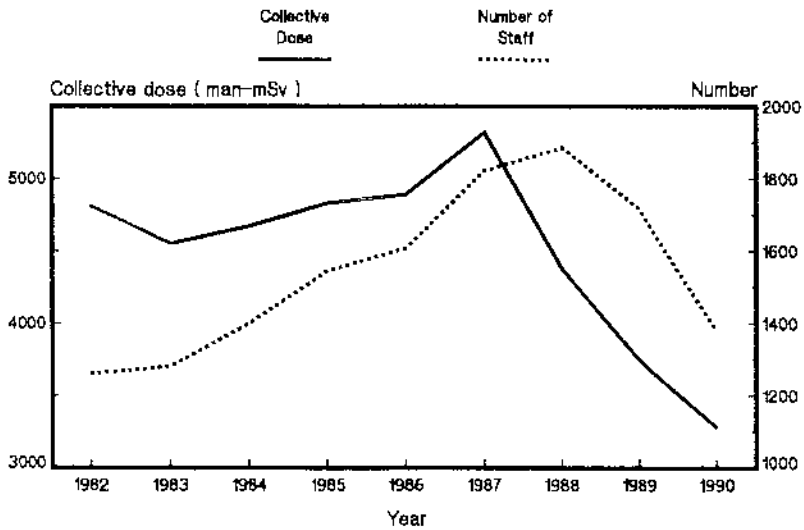

Figure 3: Numbers of staff > 15 mSv

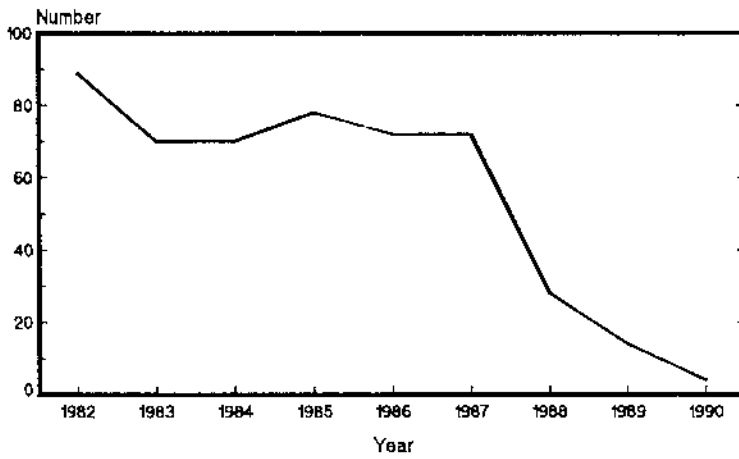
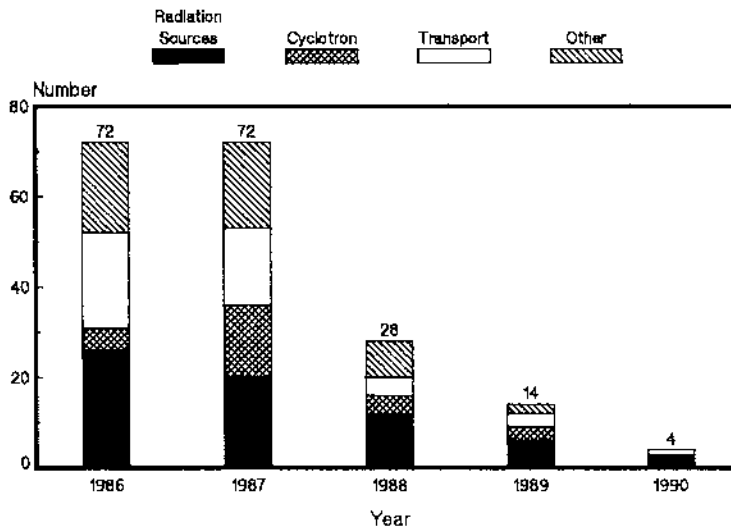

Figure 4: Work activity of staff > 15 mSv



VERY LOW ENERGY β MEASUREMENTS IN TRITIUM
CONTAMINATED PARTS

S. K. AL-ARBI, B. M. BAHAL, U. M. EL-GHAWI,
A. A. GULAK and H. H. ENBIA
T. N. R. C., P. O.Box 30878, Tripoli, LIBYA

ABSTRACT

Possibility of utilizing a gas proportional counter for routine beta activity contamination checkup in a Neutron Generator lab is explored. The sensitivity of the gas flow counter has been improved and suitable modifications made to record beta energy spectrum. Samples from all over the laboratory were collected to monitor accidental spread of tritium.

INTRODUCTION

There is a renewed interest in fast neutron generators for their use in studying radiation damage on structural materials as well as its medical application in radiation therapy of cancer cells. High flux generators usually use solid targets with Tr. adsorbed in a matrix. Intense deuterium beam desorbs the tritium, thereby, contaminating several parts of the generator. In spite of usual precautions it leaks to unexpected areas causing a possible health hazard if internally taken [1,2]. Since tritium is a very low energy pure β emitter, it escapes detection by conventional radiation detectors employed in a routine checkup. Therefore, windowless gas flow detectors are specially useful for the measurement of soft β . They have high efficiency, large solid angle and a convenient size. The counter can be successfully employed for low energy β emitters such as H^3 , Ni^{63} and C^{14} .

RESULTS AND DISCUSSION

For tritium detection a conventional 4" windowless gas counter has been developed and improved by us [1,3]. The lower limit on the electron energy was determined by sensitivity of associated amplifiers, stability of the high voltage power supply and the characteristic of the counter gas. Its sensitivity for low energy electron has been enhanced from 300 keV to less than 5 keV. The

upper limit on the electron energy producing a full spectrum due to the chamber size and gas pressure in our case was < 50 keV [4]. Other factors affecting are the absorption of electrons in the source backing and backscattering from foils. Fig.1 shows spectrum of pure H^3 and C^{14} sources measured from the modified counter. For C^{14} β only partial energy is spent in the anode chamber. The laboratory faced at several occasions contaminations of which the causes could not be ascertained. As a result more than 100 samples from all over the lab. and working rooms were collected on a Watman filter paper. Table I & II summarises the measurements of β activity of these samples. Fig.2 presents the spectrum measurement of an oil sample of ruffing pump . The pump was in operation for more than 8 years and required maintenance work. The oil was found highly active with tritium.

CONCLUSION

The use of D-T based sources exposes personnel to hazards of radiation of neutron induced activities as well as of the tritium in the targets [5]. Tritium contamination are found in unexpected areas due to the easy migration of specs which might fall down while changing of the target or during some maintenance of the beam line. Such a spread can be controlled by regular measurements of swap samples using the modified gas flow counter. Strict rules of safety should be followed during changing of tritium targets. Use of a face mask is strongly recommended. The used targets should be placed in an air tight container and stored in separate housing immediately.

REFERENCES

1. Salem Arbi and B. M. Bahal. 1st Conference on Environmental Pollution and Health Physics, Jan.1990, Sabha, Libya.
2. H.H.Barschal, Fast Neutron Physics, Proc. of the Int. Conf. on Fast Neutron Physics, Dubrovnik, Yugoslavia, 1986 .
3. Radiometric Instrument 2154-1-1M. User's Manual, Assembly and Schematic Diagrams, T. N. R.C., Tripoli,1979
- 4 W. J. Price, Nuclear Radiation Detection, 2nd Ed., McGraw-Hill

Pub., 1964, page 156.

5. R. F. Boggs, Radiobiological Safety Aspects of the Operat. of Neutron Generators. IAEA Safety Series No.42 , 1976.

TABLE I : The beta activity routine measurements between March 1987 to May 1987.

Place of Sampling	Activity Counts/S (sample)	(BackGrnd)	Comments
Control Room			
Desk	3	2	clear
Floor	3	2	clear
Window Pane	500	2	Cont.
Neutron Gnerator Room			
Wall	2100	2	High Cont
Vaccum Valve	10	2	Clear
Ground Surf.	80	2	clear
Accelerator Room			
Wall	40	2	Clear
Vaccum Valve	100	2	Clear
Non Radiation Zone			
Head Physics office	2	2	Clear
Corridor	9	2	Clear

TABLE II : The beta activity routine measurements between Dec. 1989 and January 1990.

Place of Sampling	Activity Counts/S (Sample)	(Backgnd)	Comments
Control Room			
Window Frame	30	1	Clear
Desk	2560	1	High Cont.
Floor	120	1	Cont.
Accelerator Room			
Tool Box	2300	1	High Cont.
Ion Pump Valve	1800	1	High Cont.
Non Radiation Zone			
Head Physics office	5	1	Clear
Corridor	10	1	Clear

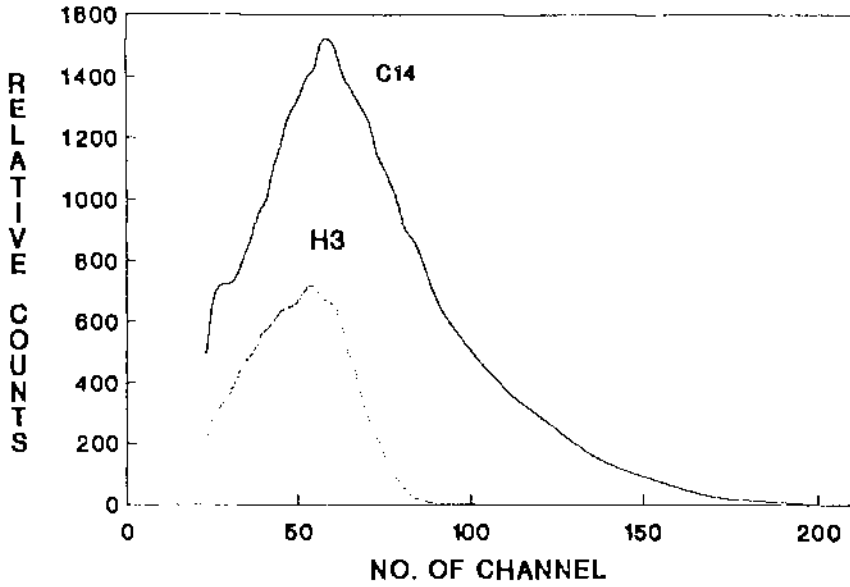

Fig.1: Beta spectrum of C14 and H3 using P-10 gas in the modified gas counter.

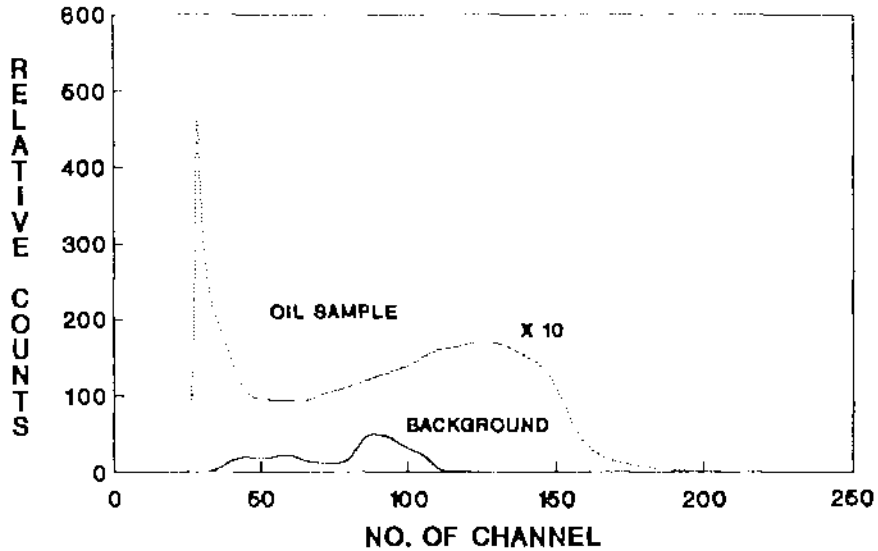

Fig.2: Beta spectrum of oil from ruffing pump of N.G.lab. It also shows background activity for identical conditions.

EXPERIENCES LIEES A L'EVALUATION DU FACTEUR DE REMISE EN
SUSPENSION D'AEROSOLS DE PLUTONIUM

G.Pescayre, J.Moll

CEA/Service de Protection contre les Rayonnements

EXPERIMENTS TO ESTIMATE THE RESUSPENSION FACTOR OF PLUTONIUM
AEROSOLS

In the field of interventions in hardly contaminated areas (60 to 100 MBq.m⁻²), we have studied the resuspension factors of plutonium aerosols and the atmospheric contamination gradient between 20 and 150 cm, to estimate the risk incurred by a lying case, compared with a standing operator. K (m⁻¹) has been evaluated between 10⁻⁶ (m⁻¹) and 10⁻⁵ (m⁻¹) without any personnel in the area, and between 10⁻⁴ (m⁻¹) and 10⁻³ (m⁻¹) with personnel.

INTRODUCTION

Un groupe de travail constitué de médecins et de radioprotectionnistes s'est interrogé sur le risque encouru par un blessé couché au sol sans protection respiratoire dans une zone fortement contaminée (activité surfacique comprise entre 3,7 et 37 MBq.m⁻²). Le facteur de remise en suspension est généralement pris égal à 10⁻⁴ m⁻¹ pour un individu en station debout mais quel est-il à 20 cm du sol au niveau de la respiration du blessé ? C'est pour répondre à cette interrogation qu'ont été entreprises, dans une zone opérationnelle où l'on n'accède qu'en tenue ventilée, des expériences visant à évaluer le gradient du facteur de remise en suspension des aérosols de plutonium entre le sol et en hauteur standard de respiration d'un individu.

ZONE DES EXPERIENCES

La zone d'expérience n'est accessible qu'en tenue ventilée. Les contaminations surfaciques sont élevées (en moyenne entre 60 et 100 MBq.m⁻²) au niveau du sol et entre 1 et 2 MBq.m⁻² sur les surfaces verticales. Le sol est recouvert d'un vinyle, enlevé périodiquement pour faciliter l'assainissement de la zone. Les locaux sont ventilés (8 renouvellements par heure) et en dépression par rapport aux sas d'entrée et aux autres locaux de l'installation (- 20 mm CE).

MATERIELS UTILISES

Les contaminations atmosphériques ont été mesurées à l'aide d'appareils de prélèvement du type SIT dont le débit est de 5 l.mn-1. Ces appareils étaient placés sur un trépied à 20 cm et à 150 cm du sol. Après prélèvement, les filtres ont été minéralisés et l'activité mesurée en spectrométrie α .

La contamination surfacique a été mesurée par frottis à l'aide d'un contaminamètre de surface du type DSM 2. 3 frottis successifs ont été réalisés en chaque point pour bien connaître la part de la contamination détachable. Une calibration préalable a été réalisée entre la réponse du contaminamètre et l'activité réellement prélevée par frottis.

DEROULEMENT DES EXPERIENCES

3 expériences ont été réalisées :

- Expérience 1 : elle avait pour objectif de mesurer le facteur de remise en suspension sans présence de personnel dans la zone.

- Expériences 2 et 3 : elles ont été réalisées en présence de 3 agents opérant dans la zone.

L'introduction du matériel de prélèvement et de mesure a fait l'objet de précautions particulières pour éviter toute contamination parasite apportée par l'environnement très contaminé de cette zone.

RESULTATS DES MESURES

La valeur du facteur de remise en suspension K (m^{-1}) a été calculée en faisant le rapport de l'activité atmosphérique C ($Bq.m^{-3}$) sur l'activité surfacique A_s ($Bq.m^{-2}$) :

$$K \text{ (m}^{-1}\text{)} = \frac{C \text{ (Bq.m}^{-3}\text{)}}{A_s \text{ (Bq.m}^{-2}\text{)}}$$

Les activités surfaciques moyennes ont été obtenues à partir des points représentatifs de la zone de travail ; avec $A_{1s} = 64 \pm 15 \text{ MBq.m}^{-2}$ et $A_{2s} = 96 \pm 10 \text{ MBq.m}^{-2}$. Le premier frottis détache 60% de la contamination non fixée.

Les facteurs de remise en suspension obtenus sont donnés dans le tableau ci-joint.

Coefficient de remise en suspension	distance (cm)	expérience 1 sans opérateur	expérience 2 avec opérateurs	expérience 3 avec opérateurs
K1 (m ⁻¹)	20	6.10 ⁻⁶	2,4.10 ⁻³	5,8.10 ⁻⁴
	150	8,7.10 ⁻⁶	2,7.10 ⁻³	1,3.10 ⁻³
K2 (m ⁻¹)	20	4.10 ⁻⁶	1,6.10 ⁻³	3,8.10 ⁻⁴
	150	5,8.10 ⁻⁶	1,8.10 ⁻³	8,9.10 ⁻⁴

COMMENTAIRES ET CONCLUSIONS

On constate qu'entre 20 cm et 150 cm l'activité volumique prélevée sur le filtre a pratiquement la même valeur, on n'a donc pas relevé de gradient de contamination atmosphérique sur la durée totale des expériences réalisées.

Les facteurs de remise en suspension sont compris entre 10⁻⁶ (m⁻¹) et 10⁻⁵ (m⁻¹) sans présence de personnel et entre 10⁻⁴ (m⁻¹) et 10⁻³ (m⁻¹) en présence de personnel. Ces facteurs relativement élevés peuvent s'expliquer par la turbulence et le massage de l'air à l'intérieur du local (8 R/h).

Un blessé séjournant une ½ heure, sans protection dans une zone contaminée au niveau de 37 MBq.m⁻² pourrait engager un équivalent de dose efficace de 0,25 Sv et 1 Sv, ce qui nécessite, sur le lieu même de l'accident de prendre des mesures telles que protection des voies respiratoires, éloignement ou évacuation la plus rapide possible.

REFERENCES :

I.S HONES and SF POND : some experiments to determine the resuspension factor of plutonium from various surfaces

GAMMA RADIATION INDUCED ALTERATIONS IN THE ULTRASTRUCTURE OF PANCREATIC ISLET, METABOLISM AND ENZYMES IN WISTAR RAT

Jayashree V. Dao and S.A. Suryawanshi
Institute of Science
Bombay 400 032
I N D I A

ABSTRACT

Effects of gamma irradiation (600 rads) on the ultrastructure of pancreatic islet, metabolism and some enzymes in wistar rat, are reported. Electron microscopic observations of endocrine pancreas revealed prominent changes in beta cells while alpha and delta cells were not much affected. Irradiation also inflicted hyperglycemia, increase in liver and muscle glycogen and decrease in insulin level. It has also increased the activity of enzymes but failed to produce significant changes in protein, lipid and mineral metabolism.

INTRODUCTION

Though large number of information is available on long term effects of radiation, studies on immediate effects are comparatively a few. This investigation deals with the immediate effects (observed after 24 hours) of gamma irradiation (600 rads) on the ultrastructure of pancreatic islet, carbohydrate, protein, lipid and mineral metabolism and some enzymes.

MATERIAL AND METHODS

Twenty acclimatized male rats were exposed to 600 rads of gamma rays (Co-60) with a dose rate of 39 rads/min. Equal number of animals served as a control group. The animals were sacrificed after 24 hours and blood samples were collected and were subject to biochemical analyses. For electron microscopic observations the pancreas was fixed in 3% glutaraldehyde and blocks were prepared in araldite. The ultrathin sections were stained with uranyl acetate and lead nitrate and observed under JEM-T-8 electron microscope.

RESULTS AND DISCUSSION

Ultrastructural changes included degenerative effects and vacuolization of the cytoplasm in alpha and beta cells (Plate I). The decrease in hormone granules was observed in beta cells while no noticeable changes were seen in alpha and delta cells. The presence of less number of hormone granules in the beta cells suggests reduction in insulin secretion which agrees well with observations in golden hamster (Tsubouchi and Sasumu, 1981).

Gamma irradiation inflicted changes in the carbohydrate metabolism and some enzymes but failed to produce significant changes in protein, lipid and mineral metabolism (Table I).

The changes in carbohydrate metabolism include pronounced hyperglycemia with a marked decline in serum insulin level. Liver and muscle glycogen showed significant increase after irradiation which can be attributed to the fact that the irradiation stimulates secretion of corticosteroids which enhances deposition of glycogen in the liver and muscle (Malatova et al., 1977).

The irradiation is known to cause an increase in gluconeogenesis from the amino acids (Kandysh and Moroz, 1979), and decrease in glucose utilisation by cells (Ahlersova, 1980). The hyperglycemia observed in the present study may be the result of release of amino acids from the destroyed tissues and less uptake of glucose by the cells.

Except for serum glutamate pyruvate transaminase, all other enzymes studied, showed significant increase in the concentrations after irradiation. This might be due to increased permeability consequent upon the disturbed metabolism. The enzymes diffuse abnormally from the cell to the plasma because of increased permeability which can be considered as an early non-specific reaction of every cell when its metabolism is disturbed.

CONCLUSIONS

Gamma irradiation reduced the synthesis of insulin as confirmed by the decrease in the hormone granules of the beta cells and decline in serum insulin level. The irradiation might have stimulated release of corticosteroids leading to hyperglycemia and deposition of glycogen in the liver and muscle. Proteins, lipids and minerals remained almost unchanged. Prominent increase in some enzymes concentration can be attributed to the diffusion of enzymes from the cell into the plasma due to change in the permeability.

REFERENCES

1. Tsubouchi and Sasumu, 1981, Radiation induced necrosis in the pancreatic islet and diabetic syndrome in golden hamster, *Int. J. Radiat. Res.*, 40, 95.
2. Malatova, Z., Sedlakova, A. and Ahlers, I., 1977, Continuous gamma radiation influence on food intake, body weight and weight of some rat organs, *Biologiya*, 32, 9, 641.
3. Kandysh, I.N. and Moroz, B., 1979, The role of radiosensitive tissues in the mechanism of post irradiation gluconeogenesis, *Dokl. An SSSR*, 195, 1242.
4. Ahlersova, E., Ahlers, J. and Paulikova, E., 1980, Tissue glycogen and blood glucose in irradiated rats - effects of non lethal dose of continuous gamma irradiation, *Folia Biologiya*, 26, 423.

ACKNOWLEDGEMENTS

Authors are thankful to the authorities of Institute of Science, Bombay and Bhabha Atomic Research Centre, Bombay, India, for providing the facilities.

Table I - Effect of gamma rays (600 rads) on various parameters.

Sr.No.	Parameter	Control	Irradiated (600 rads)
1.	Blood glucose (mg/100 ml)	84.20 ± 1.13	194.00 ± 3.56 (P < 0.001)
2.	Liver glycogen (g/100 g)	1.92 ± 0.17	6.97 ± 0.44 (P < 0.001)
3.	Muscle glycogen (g/100 g)	0.99 ± 0.06	4.90 ± 0.31 (P < 0.001)
4.	Serum insulin (IU/ml.)	115.00	50.00 ± 2.83 (P < 0.05)
5.	Serum amylase (Somogyi Units)	605.00 ± 4.40	682.00 ± 6.77 (NS)
6.	Serum lactic dehydrogenase (IU/lit.)	268.00 ± 12.50	997.00 ± 11.68 (P < 0.001)
7.	Serum glutamate oxalate transminase (IU/lit.)	70.50 ± 4.98	123.00 ± 3.56 (P < 0.05)
8.	Serum glutamate pyruvate transaminase (IU/lit.)	40.00 ± 2.77	24.00 ± 2.43 (P < 0.05)
9.	Serum acid phos- phatase (IU/lit.)	22.03 ± 1.55	24.00 ± 1.46 (NS)
10.	Serum alkaline phosphatase (IU/lit.)	8.30 ± 0.70	108.00 ± 2.92 (P < 0.001)

Note: 1) Values are given as mean ± standard error for 20 animals.
 2) P indicates the level of significance
 3) NS means non-significant.

Plate I

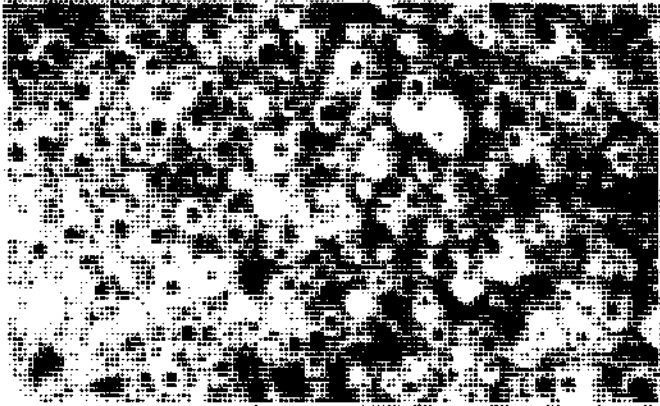

Electronmicrophotograph of beta granules
before irradiation (X10000)

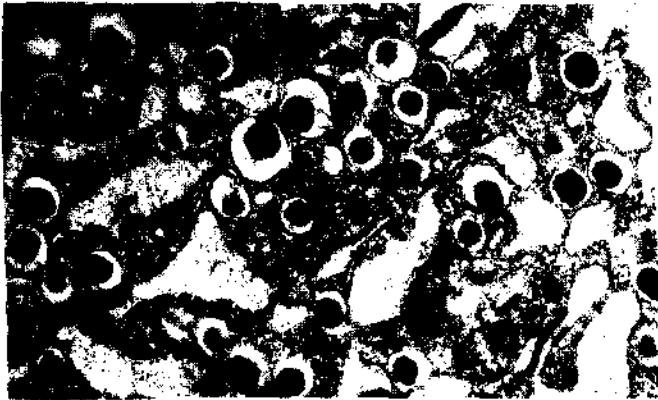

Electronmicrophotograph of beta granules
after irradiation at 600 rads (X15000)

LIFE-SPAN HEALTH EFFECTS OF RELATIVELY SOLUBLE FORMS OF INTERNALLY DEPOSITED BETA-EMITTING RADIONUCLIDES

B. B. Boecker, B. A. Muggenburg, F. F. Hahn,
K. J. Nikula, and W. C. Griffith

Inhalation Toxicology Research Institute, P.O. Box 5890, Albuquerque, NM 87185 USA

ABSTRACT: As part of a large research effort to study the lifetime health risks of inhaled radionuclides, Beagle dogs inhaled $^{90}\text{SrCl}_2$ or $^{144}\text{CeCl}_3$ or were injected intravenously with $^{137}\text{CsCl}$. Because these three compounds were soluble in body fluids, the resulting widely differing patterns of radionuclide distribution and dose reflected tissue affinities of the elements involved. Long-term health effects, predominantly cancers, were seen in the organs receiving the highest doses. Investigations are continuing on the extent to which other less irradiated organs may have also been affected.

INTRODUCTION: A major series of life-span studies on the effects of inhaled radionuclides is in progress at the Inhalation Toxicology Research Institute¹. Both fission product and transuranic radionuclides are being studied. The primary goals of these studies are to determine the life-span health risks of inhaled radionuclides, the influence of various dose- and effect-modifying factors, and to extrapolate these results to possible human exposures, particularly those for which no direct human data currently exist. One of the important areas addressed in the fission-product studies is the influence of *in vivo* solubility of the inhaled material on the doses received by, and effects seen in, different organs and tissues. This report presents and compares results from three studies in which young-adult Beagle dogs inhaled $^{90}\text{SrCl}_2$ or $^{144}\text{CeCl}_3$ or were injected with $^{137}\text{CsCl}$. This comparison was chosen because of known differences in the pattern of metabolism and dosimetry among these three radionuclides, ranging from concentration mainly in one organ (^{90}Sr), several organs (^{144}Ce), and the whole body (^{137}Cs). Of particular interest are the relative distributions of radiation dose and long-term biological effects among organs exposed by these three regimens.

MATERIALS AND METHODS: Young adult Beagle dogs (12-14 mo, equal number of both sexes) inhaled, on a single occasion, different activity levels of either $^{90}\text{SrCl}_2$, or $^{144}\text{CeCl}_3$, or were injected once, intravenously, with $^{137}\text{CsCl}$. The 224 dogs used in these studies were divided as follows: ^{90}Sr , 66; ^{144}Ce , 55; ^{137}Cs , 54; and combined controls, 49. The exposure aerosols, consisting of the radionuclide plus a CsCl or CeCl₃ vector, had polydisperse size distributions with activity median aerodynamic diameters ranging from 1.5 to 2.4 μm ($\sigma_g = 1.6$ to 2.1). Exposures were completed in less than one hour. Each dog was whole-body counted immediately after radionuclide exposure and at selected intervals thereafter to determine the initial body burden and its retention as a function of time after exposure. Each dog's health status was evaluated periodically and illnesses considered not to be associated with the radiation exposure were treated using standard veterinary practices. All dogs were maintained in the ITRI kennel facility until they died or were euthanized when moribund. Complete necropsies and histopathological examinations were performed. When all dogs in a study were dead, all clinical and histopathological results and materials were reviewed to ensure accuracy and consistency of the diagnoses. All diseases were coded for

a FOCUS database using the SNOMED system modified for dogs. Absorbed beta doses were computed for individual organs or the whole body as appropriate for the radionuclides and forms used. These dose calculations were based on the whole-body retention data from each radionuclide-exposed dog in the longevity study and tissue distribution and retention data obtained from serially sacrificed dogs in separate, but similar, dosimetry studies. The small photon contribution was ignored except for the whole-body dose from ^{137}Cs where the photon portion contributed about one-third of the total dose.

RESULTS AND DISCUSSION: Table 1 presents the experimental design features for the three studies compared in this report. In each of these studies, a range of long-term retained burdens was studied, the highest of which led to early deaths within the first two years after exposure. Most of these early deaths were from hematologic dyscrasias resulting from irradiation of the bone marrow. Several others were due to radiation pneumonitis, pulmonary fibrosis, or hepatic degeneration. The focus of this report is on the remaining ~80% of the dogs that survived more than two years after exposure and, therefore, were at risk for the development of cancer and other later-occurring diseases.

Table 1
Experimental Design Features for Life-Span Studies of Dogs Exposed to
Relatively Soluble Beta-Emitting Radionuclides

Study	LTRB ^a (MBq/kg)	Number of Dogs			
		Exposed		Controls	
		Total	> 2 y ^b	Total	> 2 y ^b
^{90}Sr	0.10 - 4.8	66	58	22	22
^{144}Ce	0.096 - 13	55	41	15	15
^{137}Cs	28 - 130	54	42	12	11

^aLTRB = long-term retained burdens for exposed dogs

^bSurvived more than 2 y after exposure

Cumulative absorbed dose factors for organs in animals exposed to these three different patterns of radionuclide distribution are given in Table 2. The organs and tissues listed for ^{144}Ce are the four that received the highest total beta doses. Of these four, only two, bone and nasal mucosa, received significant doses from ^{90}Sr . In contrast, the relatively uniform whole-body distribution of ^{137}Cs produced about the same total dose (beta plus gamma) in all four organs.

Table 2
Cumulative Absorbed Beta Doses to 5000 Days after Exposure of Beagle Dogs to Radionuclides in a Relatively Soluble Form²

Organ/Tissue	Gy per MBq/kg LTRB ^a		
	⁹⁰ SrCl ₂	¹⁴⁴ CeCl ₃	¹³⁷ CsCl ^b
Lung	--- ^c	24	0.15
Liver	---	60	0.21
Bone	220	18	0.13
Nasal Mucosa	270	92	0.18
Whole Body	N/A ^d	N/A	0.21

^aLTRB = long-term retained burden

^bDoses for ¹³⁷Cs include gamma contribution

^c--- = Dose < 0.1% of skeletal dose

^dNot applicable

Neoplasia was a prominent long-term finding in both the exposed and control dogs.^{3,4,5} Table 3 gives the number of dogs in which primary malignant or benign tumors were found. All tumors, whether they were the primary cause of death, a major contributing disease or an incidental finding, are included. For this report, the controls for the three individual studies have been combined. One can roughly compare the number of tumors across the three exposed groups and the combined controls because the number of two-year survivors was about the same in each group.

Table 3
Occurrence of Primary Tumors in Certain Organs of Dogs that were Exposed to ⁹⁰SrCl₂, ¹⁴⁴CeCl₃ or ¹³⁷CsCl and Lived > 2 y after Exposure or in Control Dogs

Organ/Tissue	Number of Tumors ^a			
	⁹⁰ Sr	¹⁴⁴ Ce	¹³⁷ Cs	Controls
Lung	2,1 ^b	3,1	3,0	5,0
Liver	0,1	10,11	5,5	0,2
Bone	45,1	1,0	--- ^c	---
Nasal Mucosa	3,0	5,0	4,0	---
Number of Dogs	58	41	42	48

^a Some dogs had more than one tumor. In addition to the tumors listed, a number of tumors were found in other organs of dogs in each of these groups; many were incidental findings at necropsy.

^b Number malignant, number benign

^c --- = No tumors

The number of lung tumors was similar in all three exposed groups and the control group. These tumors were mainly bronchioloalveolar carcinomas and adenocarcinomas in dogs that died from 10 to 16.5 y after exposure. The exceptions were two ^{144}Ce -exposed dogs that died at 4.5 and 7.6 y after exposure in which a bronchioloalveolar adenoma and adenocarcinoma, respectively, were found. In the liver, bone and nasal mucosa, pronounced differences were found between the exposed dogs and the controls. No tumors were found in these organs in the control dogs except for two bile duct adenomas in the liver. A large number of liver tumors, both malignant (hemangiosarcoma, hepatocellular carcinoma, cholangiocarcinoma and neurofibrosarcoma) and benign (biliary cystadenoma and bile duct adenoma) were found in dogs exposed to ^{144}Ce or ^{137}Cs but not to ^{90}Sr . In contrast, the tumorigenic response in the ^{90}Sr -exposed dogs was primarily the occurrence of bone tumors (osteosarcoma, hemangiosarcoma and fibrosarcoma). No bone tumors were seen in the other groups except one osteosarcoma that occurred in a ^{144}Ce -exposed dog at 2.2 y after exposure. Tumors in the nasal mucosa, mostly carcinomas, occurred in all three studies, but not in the controls. The relative distribution of tumors between the $^{144}\text{CeCl}_3$ and $^{90}\text{SrCl}_2$ studies is consistent with the dosimetry information in Table 2. The occurrence of tumors in the livers and nasal mucosa of $^{137}\text{CsCl}$ -exposed dogs indicates that these tissues are relatively responsive to this radiation insult.

These initial analyses have been directed to organs and tissues that have been clearly identified as targets of radiation from these and other internally deposited radionuclides. Investigations are continuing on the question of whether additional organs or tissues may also be at risk from these different patterns of chronic beta irradiation. These results are providing valuable *in vivo* information on the appropriateness of current radiation-protection practices for internally deposited radionuclides.

ACKNOWLEDGEMENTS: Research supported by the U.S. DOE/OHER under Contract No. DE-AC04-76EV01013 in facilities fully accredited by the American Association for the Accreditation of Laboratory Animal Care.

REFERENCES:

1. McClellan, R.O., Boecker, B.B., Hahn, F.F., and Muggenburg, B.A., 1986, Lovclace ITRI Studies on the Toxicity of Inhaled Radionuclides in Beagle Dogs, pp. 74-96 in *Life-Span Radiation Effects Studies in Animals: What Can They Tell Us?*, Rpt. CONF-830951, Eds. Thompson, R.C. and Mahaffey, J.A.
2. Boecker, B.B., Hahn, F.F., Cuddihy, R.G., Snipes, M.B., and McClellan, R.O., 1986, Is the Nasal Cavity at Risk from Inhaled Radionuclides?, pp. 564-576 in *Life-Span Radiation Effects Studies in Animals: What Can They Tell Us?*, Rpt. CONF-830951, Eds. Thompson, R.C. and Mahaffey, J.A.
3. Gillett, N.A., Muggenburg, B.A., Boecker, B.B., Griffith, W.C., Hahn, F.F., and McClellan, R.O., 1987, Single Inhalation Exposure to $^{90}\text{SrCl}_2$ in the Beagle Dog: Late Biological Effects, *JNCI*, 79, pp. 359-376.
4. Hahn, F.F., Muggenburg, B.A., and Boecker, B.B., 1991, Biological Effects of $^{144}\text{CeCl}_3$ Inhaled by Dogs, pp. 70-74 in *Annual Report on Long-Term Dose-Response Studies of Inhaled or Injected Radionuclides*, Rpt. LMF-130.
5. Muggenburg, B.A., Nikula, K.J., Boecker, B.B., Hahn, F.F., and Griffith, W.C., 1991, Biological Effects of $^{137}\text{CsCl}$ Injected in Dogs, pp. 66-69 in *Annual Report on Long-Term Dose-Response Studies of Inhaled or Injected Radionuclides*, Rpt. LMF-130.

PRELIMINARY EARLY EVALUATION OF RADIATION ACUTE SYNDROME
SEVERITY IN AN ANIMAL MODEL.

Giménez, J.C.; Nasazzi, N.B.; Taja, M.R.; Nagle, C.*; Dubner, D.;
Di Rizzio, C.**
Comisión Nacional de Energía Atómica
Centro de Educación Médica e Investigaciones Clínicas*
Academia Nacional de Medicina**

SUMMARY

To improve the knowledge of Radiation Acute Syndrome radiopathological picture, whole body X-rays irradiation at 2Gy of a primate (*Cebus apella paraguayanus*) used as model has been performed.

Early evaluations of clinical symptoms and dose and damage biological indicators have shown that this primate has given out similar responses to those of man.

INTRODUCTION

All accidental overexposures, particularly Chernobyl and Goiânia, have made evident the need to evaluate even more precisely the severity of the Radiation Acute Syndrome during the first days in order to decide the specific treatment (1,2). A delay in applying a compensatory treatment may be as fatal as an early supplying of a substitutive one (3). The difficulty in evaluating the RAS severity in the shortest time is due to complex accidental circumstances, variability in clinical response and imprecise knowledge of the underlying radiopathological mechanisms.

In order to increase and to improve the information about these infrequent events it is necessary to obtain data from animal models which may reproduce accidental situations.

Cebus apella paraguayanus is a primate which has shown cytogenetical radiosensitivity similar to that of man and this fact makes this species an interesting potential model (4).

The variables chosen to define therapeutical behaviour were:

a) Dose biological indicators (5) which may predict how deep and severe overexposure has been.

b) Damage indicators which may predict clinical evolution through the insufficiency degree of affected organs.

The information obtained from both indicators is complementary.

Intensive care of the overexposed animal model necessarily implies some analysis of the mechanisms and stages of radiation induced damage.

According to overexposure dose and dose rate, there are different degrees of insufficiency in different tissues, some of which have high vital hierarchy such as the hemopoietic, gastrointestinal and neurovascular ones. Evolution to lethal condition is not frequent when multiparenchymatous insufficiencies are not evident (6).

It is not simple to distinguish deviations of the physiological state from insufficiencies or transitory stages

strictly physiologically generated by the lost of functional balance. It is necessary to develop a repeatable quantificator to diagnose insufficiency and its severity degree, particularly when RAS clinical and humoral expressions appear relatively late.

All above mentioned leads to a wide physiopathological approach such as that applied to Multiple Organ System Failure (7,8).

Radiation Acute Syndrome objective evaluation needs to take into account severity and chronometry of dose and damage biological indicators.

The aim of this work is to establish multiple correlations between dose and damage indicators observed during the first 2 or 3 days to in order to:

- Found therapeutic decisions.
- Interpret radiopathological mechanisms.
- Train medical staff to assist accidentally overexposed people.

MATERIAL AND METHODS

An adult female primate has been X-Rays whole- body irradiated with the following exposure conditions: 200 Kvp. 10 mA, 0,25 Gy/min.

Previous dosimetry with a phantom and TLD dosimeters have been performed. The entrance dose has been 2 Gy and outlet dose has been 1.8 Gy.

A LD50 of approximately 4 Gy is supposed.

RESULTS

1) Dose indicators

a) Cytogenetical Dosimetry: dicentric + rings/cell has been 0.38 dic.+rings/cell (human frequency: 0.34 dic + rings/cell).

b) Taurine quantification: in 24 hours taurine in plasma had not increased as expected, whereas a non identified compound, next in its position in the chromatography column, had.

c) α -amylase has doubled in 6 hours, while TGO, CPK and LDH have increased 24 hours post irradiation 4,20 and 10 times respectively.

2) Damage indicators

a) Blood parameters

-Peripheral blood: the kinetics of blood cells concentration related to time for equal dose, has been similar to that of man, though it has shown a more marked tendency to cell depletion, except for platelets. Neutrophiles increased 260%, 24 hours later. During this time lymphocytes have decreased 50%. From this moment neutrophiles have reached the lowest value (20%) in 20-22 days. Lymphocytes have reduced to minimal value (14%) 8 days post-irradiation.

Platelets have increased 175% in 24 hours for later fluctuations between 75% to 125% of control values. Reticulocytes have increased 4% in 48 hours; they have reduced to minimum (0.12%) the 6th. day post-irradiation and have fluctuated during follow-up between 0.5% and 1% .

-Bone marrow: Previous to irradiation, slides for mononuclear cells recognition, reccount and recovering have been performed (24 E6 cells/ml.).

A few hours after irradiation cell changes had not been observed yet. On the 14th. day post-irradiation an 370% lymphocyte increase and megakaryocytes disappearance has been observed.

Cultures from a withdrawal made some hours after irradiation have not developed colonies; only a fibroblastic type monolayer has been formed.

The cultures set-up on the 14th. day post-irradiation has developed CFU-GEMM colonies, whose size was similar or slightly inferior to that of man, particularly erythrocytes "burst" type, having few hemoglobinized cells.

Mors than 50% of granulocytes colonies have immature cells. The number of colonies has decreased in all lineages except for some very compact macrophagic colonies, whose number has increased.

The cell stroma was abundant till 14th. day; then its decreased till all cells disappeared one month later.

b) Metabolic parameters

The acid-base balance has moved towards metabolic acidosis. Chloride has significantly increased. Glucemia has doubled in 24 hours and at the same time uremia has decreased.

c) Endocrinological parameters

Premature luteinization of the growing follicule has been observed, with a later insufficient luteal phase.

Thyroid parameters have ranged within control values. T3 has had greatest fluctuations.

CONCLUSIONS

A preliminary assay of primate acute overexposure evaluation has given out similar responses to those of man, even though hemopoietic radiosensitivity (except for platelets) has been more marked than human.

Cell kinetics has been similar.

Deep changes in bone marrow cell stroma has been observed. However, in 50 days recovery has been complete.

The stable platelet concentration is associated with high megacaryocytes proliferation.

Metabolic parameters and acid-base state have been modified with the same trend as that of man but more highly marked.

There has been an outstanding premature luteinization of growing follicule.

Primate has not shown clinical manifestations during the period of observations. The handling of the animal model has been an adequate stage of operative training for medical personnel who treat overexposed people.

REFERENCES

- 1- Summary report on the post accident review meeting on the Chernobyl accident. IAEA, Vienna. International Safety Group (INSAG) Vienna (1986)
- 2- The radiological accident in Goiania. Medical response. IAEA, Vienna (1988)
- 3- Gale, R.P. The role of bone-marrow transplants after nuclear accidents. *The Lancet* 23:923-926 (1988)
- 4- Nasazzi, N.; Taja, M.R.; Nagle, C.; Gimenez, J.C. Cytogenetical evaluation of a new animal model for radiobiological studies (this issue) (1992)
- 5- Kaul, A.; Dehos, A.; Bogl, N.; Hinz, G.; Kossel, F.; Schwarz, E.R.; Stamm, A.; Stephan, G. Biological indicators for radiation dose assessment. Medizin Verlag Munchen
- 6- Pujado, J.F.; Doghoss, R.; Hernandez, M.S.; Egurrola, M.A. *Sindrome de Fracaso Organico Multiple* Hernandez Editores (1990)
- 7- Madoff, R.; Fath, J.J.; Cerra, F.B. Metabolic basis of multiple system organ failure. *The Lancet* 1:514 (1984)
- 8- Draper, E.D.; Knaus, W.A.; Wagner, D.; Zimmerman J. Prognosis from combined organ system failure. A natural study. *Crit. Case Med.* 11:236 (1983)

Class I and II HLA antigen expression after a 10 Gy-4 hour total body irradiation

J.M. COSSET (1)(3), C. RAFFOUX (2), M.P. CHAILLET (1),
G. SOCIE (1), J. Y. FOLLEZOU (4), T. GIRINSKY (1).

(1) Institut Gustave Roussy - 94800 VILLEJUIF - France
(2) France Transplant - Hôpital Saint Louis - 75010 PARIS - France
(3) Institut Curie - 75005 PARIS - France
(4) Service de Radiothérapie Cancérologie - Hôpital de La Salpêtrière - 75013 PARIS - France

SUMMARY

Class I and II HLA antigenic expression was explored before and at various intervals after a 10 Gy total body irradiation delivered in 4 hours, before allogeneic bone marrow graft for various hematologic malignancies. A reliable class I HLA typing appears to be possible in almost all cases 6 to 8 hours after the start of irradiation, but is only possible in 5/12 patients after 24 hours. Preliminary results with class II antigens might suggest a still higher "fragility" of this antigen class. These results urge to take blood samples for HLA grouping as soon as possible after an accidental whole body irradiation.

INTRODUCTION

In a situation of accidental total body irradiation, allogeneic bone marrow transplantation from a HLA-compatible donor may represent the only therapeutic solution. In such a case, the class I and II HLA antigenic profile of the irradiated recipient must be precisely known, in order to be able to look for a HLA compatible donor among the relatives or in a donor "bank".

The total body irradiation (TBI), part of the conventional conditioning regimen before bone marrow transplantation for various hematologic malignant disorders (mostly leukemias), represents an interesting "model", since it mimicks an accidental high-dose whole body irradiation.

This model was used in a series of 14 patients to study the expression of class I and II antigens after a 10 Gy-4 hour therapeutic TBI, in order to try and answer the questions : is it possible to define a precise HLA typing after such an irradiation ? And, if yes, how long after TBI the identification of a precise HLA profile remain possible in those patients ?

METHODS AND MATERIALS

a) Irradiation technique

The series is comprised of 14 patients who were given a total body irradiation by 18 MV photons of a linear accelerator (SATURNE GE-CGR MeV), using two antero-posterior and postero-anterior beams at a SSD (Skin-Source Distance) of 4 meters, according to usual technique of the Institute Gustave Roussy.

The total dose, calculated at mid-depth of the abdomen, was 10 Gy. The lung dose was reduced to 8 Gy by an appropriate lead shielding.

The irradiation was delivered in an overall time period of 4 hours with several interruptions. The "instantaneous" dose rate was 12 cGy/min,

while the "mean" dose rate (taking into account the 4 hour setting) was about 4 cGy/min.

A double extemporaneous in vivo dosimetry (semiconductors and thermoluminescent dosimeters) precisely ensured the delivery of the prescribed dose.

An additional chemotherapy, usually using cyclophosphamide, was systematically given **AFTER** irradiation (more than 24 hours afterwards), therefore non interfering with this study of antigen expression in the first 24 hours after irradiation.

b) Patients

Fourteen patients were entered in the study. Sex, age and disease are reported in table 1.

TABLE 1 :

Patient	Sex	Years	Type of disease
1	F	26	Hodgkin's disease (HD)
2	F	21	Chronic Myelogeneous Leukemia (CML)
3	M	55	Myeloma
4	M	30	CML
5	M	4.5	Acute lymphoblastic Leukemia (ALL)
6	M	38	Acute Myeloid Leukemia
7	F	34	CML
8	M	24	Lymphoblastic Lymphoma (LL)
9	M	21	LL
10	F	21	LL
11	F	38	CML
12	M	21	ALL
13	M	22	CML
14	M	21	Low grade Non Hodgkin's Lymphoma

c) Class I and II HLA subtyping was performed using the conventional serologic technique (microlymphocytotoxicity). We considered, as widely accepted, that a minimum antigenic expression of 70 % was necessary for the typing to be reliable. Molecular biology procedures were not utilized in this study.

RESULTS

1) Class I HLA antigens.

The mean expression of class I HLA antigens **before** irradiation (HC), then 6, 8, 17 and 24 hours after the **initiation** of the 10 Gy- 4 hour irradiation, respectively, is given for each patient in table 2.

TABLE 2 :
Class I HLA antigen Mean expression.

Patient	H0	H6	H8	H17	H24
1	78.75 %	83.65 %	n.d	n.d	63.25 %
2	46.14 %	52.20 %	n.d	n.d	14.43 %
3	69.92 %	66.59 %	n.d	n.d	0%
4	95.57 %	89.38 %	n.d	n.d	0%
5	95.83 %	83.33 %	n.d	n.d	73.61 %
6	82.95 %	78.66 %	n.d	n.d	81.16 %
7	100.00 %	73.96 %	n.d	n.d	31.77 %
8	71.73 %	71.35 %	n.d	n.d	0%
9	97.97 %	n.d	88.07 %	n.d	74.48 %
10	77.86 %	n.d	69.53 %	n.d	61.20 %
11	81.94 %	n.d	72.22 %	65.63 %	62.50 %
12	82.50 %	n.d	63.13 %	n.d	n.d
13	100.00 %	n.d	100.00 %	87.78 %	87.78 %
14	97.92 %	n.d	96.35 %	91.88 %	83.54 %

(n.d : not done)

- **Before** irradiation, Class I HLA typing appears to be reliable in 13/14 patients.
- **Six hours** after the irradiation start, HLA typing remains possible for all the 7 tested patients for whom typing was initially possible.
- **Eight hours** after the beginning of irradiation, 4 out 6 tested patients exhibit a sufficient antigenic expression for a reliable typing.
- **At 17 hours**, the number of tested patients (3) is too small for any serious conclusion to be drawn.
- **Twenty-four hours** after the irradiation start, a class I HLA antigen typing could be reliably performed in only 5 out of 12 tested patients with initial reliable typing.

Table 2 emphasizes the large interindividual variations of the mean value of class I antigenic expression over time. Moreover, for a given patient, we were able to demonstrate different evolutions with time of the expression of the various class I antigen (data not shown), thus suggesting different "fragilities" of the various class I antigens after irradiation ; A1, B35 and B44 expression would seem more "resistant" after irradiation in this series.

2) Class II HLA antigens

This study was initiated later ; this explains why only 6 patients were explored.

Before irradiation, only 4 patients out of 6 could benefit from a precise class II HLA typing (possibly because of the type of previous chemotherapy in 2 patients (?)).

Three of the 4 patients with initial typing were tested at 8 hours ; class II antigen typing was still possible in 2 cases.

Twenty four hours after the irradiation, class II antigenic typing was only possible in one case out of the 4 initially reliably typed.

CONCLUSIONS

- For class I histocompatibility antigens, a precise typing seems to be possible in a majority of cases 6 to 8 hours after the start of a 10 Gy-4 hour total body irradiation, but is only possible in 5/12 patients at 24 hours.

- For class II HLA antigens, the small number of patients presently enrolled in our study precludes any valid conclusion. Our preliminary data could only suggest a "sensitivity" to irradiation -at least- equal to the one of class I antigens.

These results urge to take blood sample for HLA typing as soon as possible after an accidental irradiation, since a 20-24 hours delay would preclude the precise HLA typing of an irradiated individual in a significant proportion of cases.

In case of impossibility of HLA grouping by serologic techniques, one should be ready to resort to the new of molecular biology techniques.

CHRONIC IONIZING RADIATION EXPOSURE
AS A TUMOR PROMOTER IN MOUSE SKIN

R.E.J. Mitchel and A. Trivedi

AECL Research
Chalk River Laboratories
Chalk River, Ontario, Canada

ABSTRACT

We have tested a chronic exposure to ^{90}Y beta-radiation as a tumor promoter in mouse skin previously exposed to a chemical tumor initiator. Three different tests of radiation as a stage I tumor promoter, in skin subsequently given chemical stage II promotion, all indicated that the beta-radiation acted as a weak stage I skin tumor promoter. It showed no action as either a stage II or complete tumor promoter.

INTRODUCTION

Tests of ionizing radiation for its action at the promotion step in the multi-step process of carcinogenesis have usually indicated a lack of tumor promotion by single or multiple doses of radiation (1,2). One test of γ -radiation as a stage I promoter, given as two doses of 1.0 Gy each to DMBA initiated mouse skin, and followed by a chemical stage II promoter also failed to produce tumors (3). In spite of these negative results, exposure of cells to ionizing radiation results in expression of protein kinase C, *C-jun* and *C-fos* (4,5), molecular changes associated with tumor promotion. *In vivo* tumor promotion by ionizing radiation may therefore occur only at certain doses or dose rates. In this paper we present the results of our tests of chronic exposure to ^{90}Y beta-radiation as a stage I, stage II or complete tumor promoter in mouse skin.

EXPERIMENTAL MEASUREMENTS

Groups of female 7-8 week old SENCAR mice had their dorsal skins initiated by a single topical application of 10 nmol of the carcinogen 7,12, dimethylbenz(a)anthracene (DMBA, in acetone). Some groups subsequently received the complete chemical tumor promoter 12-O-tetradecanoylphorbol-13-acetate (TPA, 2 μg in acetone, twice/week) for 13-20 weeks, after which time multiple skin tumors appeared on the mice. For some groups chemical promotion was broken into two steps, stages I and II. Those groups received TPA stage I promotion, as above for 2 weeks only, followed by mezerein (4 μg) applied in the same protocol for an additional 13 weeks. Multiple skin tumors also appeared after this treatment. Some groups had their dorsal skins irradiated with a ^{90}Y source at a surface dose rate of 13.4 mGy/s, twice/week for varying periods (chronic exposure).

Table 1 shows the results of two tests of multiple 0.5 Gy β -radiation exposures as a complete promoter in DMBA initiated skin. Used alone this radiation exposure produced no tumors, and in conjunction with the complete chemical promoter significantly reduced ($p < 0.001$) the tumor

frequency. The reduction in tumor frequency may be attributable to radiation induced death of initiated cells.

Table 1: Chronic β -Radiation Exposure as a Complete Tumor Promoter.

Test No.	Treatment*	No. Animals	Tumors/Animal + SD
1	DMBA + No promotion	23	0
	DMBA + TPA (13 weeks)	25	9.72 \pm 0.45
	DMBA + 0.5 Gy (13 weeks)	100	0
2	DMBA + TPA (15 weeks)	25	14.21 \pm 0.30
	DMBA + TPA + 0.5 Gy (15 weeks)	22	9.88 \pm 0.54

* TPA treatment twice per week
0.5 Gy exposure twice per week.

Table 2 shows the tests of chronic exposure to β -radiation used as a stage II promoter in a two stage promotion protocol. DMBA initiated skin, stage I promoted with TPA (2 weeks) followed by 13 weeks of chemical stage II promotion by mezerein produced multiple tumors/animal. Substituting β -radiation exposure (0.5 Gy, twice/week, 13 weeks) for mezerein resulted in essentially no tumors indicating that this radiation exposure did not act as a stage II promoter. The reduced tumor frequency seen when chronic radiation exposure was given prior to or with the chemical stage II promoter, again may be attributable to radiation induced cell death.

Three protocols were used to test chronic radiation exposure as a stage I tumor promoter (Table 3). In the first, initiated skin was subsequently exposed to radiation alone as a stage I promoter followed by chemical stage II promotion. For the second protocol, initiated skin was subsequently treated with a combination of radiation and a chemical stage I promoter (TPA), followed by chemical stage II promotion. The third protocol gave the radiation exposure entirely preceding the initiation, which was then followed by chemical promotion. In all three cases the radiation significantly ($p < 0.05$) increased the tumor frequency, in spite of the concurrent, radiation induced loss of initiated cells shown in Tables 1 and 2.

At the doses and dose rates tested the action of β -radiation as a stage I tumor promoter was weak in comparison to the chemical promoters, consistent with its relatively weak action as a tumor initiator (6) or progressing agent (1). However, its promotion action was offset by its apparent lethal action on initiated cells. At lower dose rates, lethal effects may diminish and enhance the effectiveness of radiation as a promoter.

Table 2: Chronic β -Radiation Exposure as a Stage II Tumor Promoter.

TREATMENT*	NO. ANIMALS	TUMORS/ANIMALS \pm SD
DMBA \rightarrow TPA \rightarrow Mezerlein (2 wks) (13 wks)	24	6.05 \pm 0.29
DMBA \rightarrow TPA \rightarrow no treatment (2 wks) (13 wks)	25	0
DMBA \rightarrow TPA \rightarrow 0.5 Gy (2 wks)(13 wks)	25	0.14 \pm 0.03
DMBA \rightarrow TPA \rightarrow 0.5 Gy + Mezerlein (2 wks) (13 wks)	25	4.79 \pm 0.26
DMBA \rightarrow TPA \rightarrow 0.5 Gy \rightarrow Mezerlein (2 wks)(13 wks) (13 wks)	25	4.53 \pm 0.28

* TPA, Mezerlein and/or radiation (0.5 Gy) were all applied twice per week for the indicated time.

Since stage I promotion can occur prior to the DNA damaging initiating event in cells (7), it is likely to depend on an inducible biological process which subsequently acts on the initiated cell to produce the change necessary for this step in carcinogenesis. We have other (unpublished) evidence that tumor promotion is a process which occurs naturally, in the absence of stimulation by chemical or physical agents. We suggest that the chronic radiation exposure prior to or after tumor initiation stimulates this natural process, such that when an initiating event occurs, there is an increased probability that stage I promotion will also occur and tumor frequency will consequently rise.

Table 3: Chronic β -Radiation Exposure as a Stage I Tumor Promoter.

Test No.	Treatment*	No. Animals	Tumors/Animal \pm SD
1	DMBA \rightarrow No treatment \rightarrow Mezerlein (13 wks) (13 wks)	24	3.46 \pm 0.16
	DMBA \rightarrow 0.5 Gy \rightarrow Mezerlein (13 wks) (13 wks)	25	3.99 \pm 0.23
2	DMBA \rightarrow TPA + Mezerlein (2 wks) (13 wks)	24	6.05 \pm 0.29
	DMBA \rightarrow TPA + 0.5 Gy \rightarrow Mezerlein	25	6.95 \pm 0.43
3	MNNG \rightarrow TPA (20 wks)	25	4.73 \pm 0.23
	0.5 Gy \rightarrow MNNG \rightarrow TPA (4 wks) (20 wks)	23	5.47 \pm 0.37

* Chemical tumor promotion or radiation exposure (0.5 Gy) was twice per week.

CONCLUSIONS

Chronic exposure to ^{90}Y beta-radiation does not act as a complete tumor promoter or a stage II tumor promoter in mouse skin previously exposed to a tumor initiator. However, it does act as a stage I skin tumor promoter possibly by stimulating or inducing a naturally occurring stage I tumor promotion process in cells. This result suggests that chronic exposure to radiation may increase the risk of tumor formation in persons exposed to a previous or subsequent tumor initiating dose.

REFERENCES

1. Jaffe, D.R., Williamson, J.F. and Bowden, G.T., 1987, Ionizing radiation enhances malignant progression of mouse skin tumors, *Carcinogenesis* 8, pp. 1753-1755.
2. Ootsuyama, A. and Tanooka, H., 1987, The tumor-initiating and promoting effects of ionizing radiations in mouse skin, *Jpn. J. Cancer Res. (Gann)* 78, pp. 1203-1206.
3. Schwarz, M., Peres, G., Kunz, W., Fürstenberger, G., Killstein, W., and Marks, F., 1984, On the role of superoxide anion radicals in tumor promotion, *Carcinogenesis* 5, pp. 1663-1670.
4. Woloschak, G.E., Chang-Liu, C.-M., and Shearin-Jones, P., 1990, Regulation of protein kinase C by ionizing radiation, *Cancer Res.* 50, pp. 3963-3967.
5. Sherman, M.L., Datta, R., Hallahan, D.E., Weichselbaum, R.R. and Kufe, D.W., 1990, Ionizing radiation regulated expression of the c-*jun* protooncogene, *Proc. Natl. Acad. Sci. U.S.A.* 87, pp. 5663-5666.
6. Jaffe, D.R. and Bowden, G.T., 1986, Ionizing radiation as an initiator in the mouse two-stage model of skin tumor formation, *Radiat. Res.* 106, pp. 156-165.
7. Fürstenberger, G., Kinzel, V., Schwanz, M. and Marks, F., 1985, Partial inversion of the initiation-promotion sequence of multistage tumorigenesis in the skin of NMRI mice, *Science* 230 76-78.

GENE CONVERSION IN YEAST AS A FUNCTION OF LINEAR ENERGY
TRANSFER (LET) FOR LOW-LET RADIATION

J.R. Johnson*, P. Unrau and D.P. Morrison

Atomic Energy of Canada Limited, Chalk River Laboratories,
Chalk River, Ontario KOJ 1J0

*Current address: Pacific Northwest Laboratory, Richland,
Washington 99352

ABSTRACT

The relative biological effectiveness (RBE) for low linear energy transfer (LET) radiation is known to depend on such factors as LET and dose rate. Microdosimetric calculations indicate that the biological target size could also be an important parameter, and calculations predict that the RBE for effects produced by hits in target sizes below about 100 nm should be unity for all low-LET radiation. We have measured the RBE for gene conversion in yeast (a small target) for five different low-LET photon sources, and the results were consistent with an RBE of unity. This finding is consistent with microdosimetric predictions.

INTRODUCTION

Radiation quality is normally estimated using the linear energy transfer (LET). Radiation with LETs less than 10 keV μm^{-1} are called low-LET, and the quality-factor-versus-LET relationship predicts a range in radiation quality of about 0.5 to 2.⁽¹⁾ Similar values are predicted when the quantity of linear energy is used to define radiation quality.⁽²⁾ However, linear energy theory predicts that radiation quality is dependent on the size of the biological target, and the theory also predicts that the ratio of tritium beta rays (LET ≈ 6.5 keV μm^{-1}) to ^{60}Co gamma rays (LET < 1 keV μm^{-1}) has a maximum of about 3 for target sizes of 1 to 3 μm , and decreases to unity for smaller and larger target sizes.⁽³⁾

Gene conversion in irradiated yeast is generally thought to result from DNA damage in the immediate vicinity of the mutant gene. Such damage presents a small target that can be used to test microdosimetric predictions. The repair of this damage can result in the mutant gene's being converted to the "wild" type that will form colonies when plated onto growth medium. These colonies can be counted; thus, the conversion yield is considered a function of dose estimated.⁽⁴⁾

EXPERIMENTAL

Two mutant varieties of the yeast *Saccharomyces cerevisiae* were first irradiated with five different sources of low-LET radiations normally encountered in the workplace.

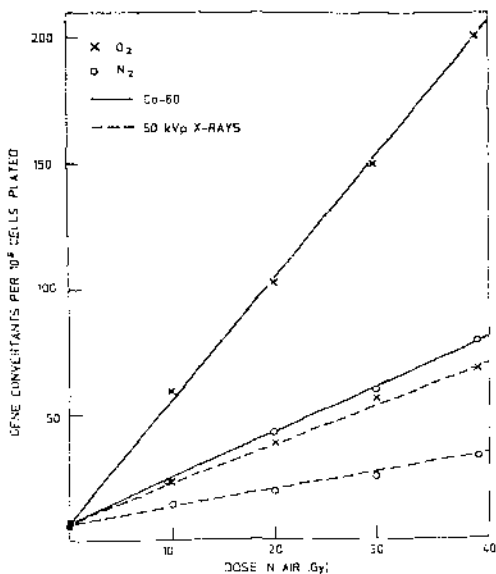

Fig. 1. Typical results obtained for gene conversion yield as a function of dose. The dose to cells from the 50 kVp x-rays is considerably less than the dose in air.

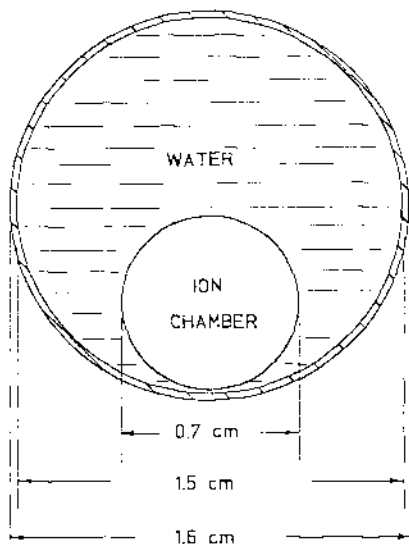

Fig. 2. Experimental arrangement to measure doses to cells. The ion chamber was at an equal dose position to the lucite test tubes containing yeast cells in suspension.

After each exposure, gene-conversion yields in the yeast were measured (see Fig. 1). The following radiations were used: 50 to 150 kVp x-rays from a thin window (2.5 mm Be) x-ray tube, 150 and 300 kVp x-rays from a thick window (0.4 mm Cu) x-ray tube, and ⁶⁰Co gamma rays. The x-rays emitted from the thin window tube have a much higher LET (50 kVp thin window $\approx 7.5 \text{ keV } \mu\text{m}^{-1}$, 150 kVp thin window $\approx 2.5 \text{ keV } \mu\text{m}^{-1}$) than those from the thick window tube (150 thick window = $1.5 \text{ keV } \mu\text{m}^{-1}$, 300 thick window = $1.0 \text{ keV } \mu\text{m}^{-1}$). The gamma rays from ⁶⁰Co have an even lower LET ($\approx 0.26 \text{ keV } \mu\text{m}^{-1}$). The dose rates used in all the experiments were about 100 rad/min, which, as shown by the authors' previous experience with this system, is well below that which produces dose rate effects.⁽⁴⁾

Cells were suspended in growth medium in lucite test tubes (see Fig. 2) and maintained at 0°C (ice bath) during irradiation. To give yields under both oxic and anoxic conditions, either air (O₂) or nitrogen (N₂) gas was bubbled through the medium.

Typical results are shown in Fig. 1. The slopes (b_1) of straight line fits to the data were estimated and their ratios and uncertainties obtained from the formula

$$R = \frac{b_x}{b_y} \pm \left[\frac{\Delta b_x^2}{b_y^2} + \frac{b_x^2 \Delta b_y^2}{b_y^2} \right]^{1/2}$$

These slopes are given in Table 1. Δb_i are the uncertainties returned by the fitting routine.

The much lower yield for the 50 kVp irradiation was because the average dose to cells for these low-energy x-rays is much smaller than that in air. (Absorption of radiation by the lucite tube and by the suspension caused this reduction in dose.) For all irradiations, the absorption was estimated using two methods. First, theoretical energy spectra of the x-rays were used to calculate the average dose to cells by using known absorption cross sections. These values were then checked by inserting the ion-chamber into a water-filled tube (Fig. 2) and measuring the average dose. The correction for absorption was applied to the ratio of slopes to obtain the RBEs in Table 2.

DISCUSSION AND CONCLUSION

The estimated RBEs (Table 2) for the TRP (N_2) mutant are all less than 1, and those for the HIS (O_2) are all greater than 1, indicating that there may be some unexplained bias in the results. However, the overall results are consistent with an RBE close to unity and serve as experimental support for the predictions of the microdosimetric theory that the RBE for low-LET irradiation of small biological targets is approximately one.

REFERENCES

1. International Commission on Radiological Protection. Recommendations of the International Commission on Radiological Protection. Publication 26, Pergamon Press, New York (1977).
2. The Quality Factor in Radiation Protection. International Commission on Radiological Protection and International Commission on Radiation Units and Measurements. Publication 40, ICRU, Bethesda, Maryland (1986).
3. J. Booz and H.G. Paretzke. Microdosimetric considerations for the quality factor of tritium. Radiation Protection. Commission of the European Communities Report. EUR8712EN (1984).
4. D.P. Morrison, R.V. Osborne, and P. Unrau. Beta ray induced gene conversion in yeast. Radiat. Res. 87, 50-58 (1978).

TABLE 1. Ratio of the slopes obtained from the straight line fitting routine to the gene conversion data (See Fig. 1). The values in parentheses are twice the standard error calculated from the error estimate in the slope as returned by the fitting routine. Experiment (1) results are with the thick window x-ray set, and (2) results are with the thin window.

Experiment	Ratio of Slopes			
	TRP		HIS	
	O ₂	N ₂	O ₂	N ₂
300 (1)	1.02(0.03)	0.84(0.05)	0.99(0.07)	0.95(0.05)
150 (1)	1.00(0.03)	0.92(0.03)	0.97(0.07)	0.94(0.05)
150 (2)	0.42(0.03)	0.41(0.01)	0.51(0.03)	0.48(0.02)
50 (2)	0.34(0.03)	0.31(0.01)	0.41(0.04)	0.34(0.03)

TABLE 2. RBEs for gene conversion in yeast induced by the indicated x-rays, as compared to ⁶⁰Co gamma rays. The values in parentheses are twice the standard error, including the estimated contribution from uncertainty in dose estimates. Experiment (1) results are with thick window x-ray set, and (2) results are with the thin window.

X-ray Source	Corrected RBE			
	TRP		HIS	
	O ₂	N ₂	O ₂	N ₂
300 (1)	1.07(0.05)	0.88(0.06)	1.04(0.08)	1.00(0.06)
150 (1)	1.05(0.05)	0.97(0.05)	1.02(0.08)	0.99(0.06)
150 (2)	0.93(0.08)	0.91(0.06)	1.13(0.08)	1.07(0.07)
50 (2)	1.02(0.14)	0.93(0.11)	1.23(0.17)	1.02(0.14)

ACKNOWLEDGMENT

The advice on dosimetry provided by A. R. Jones and A. Ohno of CRL is gratefully acknowledged. Pacific Northwest Laboratory is operated for the U.S. Department of Energy by Battelle Memorial Institute under Contract DE-AC06-76RLO 1830.

TAURINE AS A BIOLOGICAL DOSIMETER. ITS DETERMINATION IN
PHYSIOLOGICAL SAMPLES BY REVERSED PHASE HIGH-PERFORMANCE
LIQUID CHROMATOGRAPHY.

Dubner, D; Fernandez, M.

Comisión Nacional de Energía Atómica
Centro Atomico Ezeiza
Buenos Aires, Argentina.

ABSTRACT

Taurina, which is the metabolic end-product of cysteine shows a dose dependent change in urinary excretion after radiation exposure. The results of whole body gamma irradiated rats with doses of CO-60 ranging from 100 cGy to 800 cGy are expressed as percent increase of taurine in urine in the first 48 hours postirradiation and confirm the existence of a linear relationship.

INTRODUCTION:

To predict the medical consequences of accidental irradiation, the absorbed dose has to be determined with a sufficient degree of accuracy and precision. It is also essential that the dose information can be produced within an acceptable time period, before clinical symptoms requiring important medical treatment are manifest. So, known dose effect relationship reproducibility of observations and early availability of results are some of the basic requirements for practical applicability of bio-indicators.

Biochemical analysis of the metabolic patterns in the body can provide information on cellular disturbances that may arise due to the radiation exposure.

There is a general increase in the levels of aminoacid in the urine of animals and humans during the first day after irradiation.

The relative enhancement depends on the absolute excreted amount and on the metabolism of the specific aminoacids. Accordingly, the excretion of aminoacids is not usually an appropriate indicator.

However, taurine, a metabolic end product of the aminoacid cysteine, shows a dose dependent change in urinary excretion after irradiation.

Raghavan et al. (1) showed a linear dose-response relationship in urinary taurine of rats measured at 24 Hs. postirradiation with dose ranging from 100 cGy to 800 cGy of X rays.

In this work we estimated taurine in urine collected during the first 48 hours postirradiation, and the results are expressed as percent increase respect to control value.

MATERIALS AND METHODS:

Normal male rats (Wistar) weighing 200-250 g, maintained on stock laboratory diet, were used in the experiments.

Whole body gamma irradiation was carried out with Co-60 Picker C4M60 unit at a rate of 29.3 cGy/min, total doses ranging 100 to 800 cGy.

The rats were housed in individual metabolic cages for urine collection. The urine was collected at intervals of 24h, in flasks containing a few drops of toluene.

It was ensured that there was no contamination of urine by water and faeces.

Taurine was analysed by reversed-phase HPLC after mixed-bed ion-exchange clean up and precolumn derivatization with Dansyl Chloride based on the method of Marquez et al. (2).

Briefly, 1 ml samples of urine were deproteinized adding 0.1 ml 3.2 M of perchloric acid and filtered through an ion-exchange clean up column to remove aminoacids that could interfere with taurine separation by HPLC. Columns were prepared according to Larsen et al. (3).

Separation of Dansyl derivatives was carried out on a 5 μ m Supelcosil LC-18 reversed phase column (150 x 4.6 mm I.D., Supelco, Bellefonte, PA, U.S.A.).

Two mobile phases were used: a) methanol 14%, b) 0.6% acetic acid with 0.008% triethylamine in water solution (30:70). It was delivered at a flow rate of 1.5 ml/min and constant room temperature. Detection at 250 nm of wavelength were performed.

RESULTS:

The excretion values of urinary taurine of rats at 24, 48 and 72 hours after exposure are shown in table 1.

TABLE 1

URINARY EXCRETION OF TAURINE (μ moles/24 hours)

Dose (cGY)	100	300	500	600	800
Control*	76.0	87.2	77.1	30.4	50.
S.D.	30.1	35.0	31.6	9.9	19.2
24 Hours	57.8	126.7	130.0	52.0	100.6
S.D.	20.2	53.2	49.0	16.6	27.2
48 Hours	24.2	32.2	67.3	36.5	57.7
S.D.	7.7	10.2	20.1	14.6	17.8
72 Hours	38.7	60.3	47.2	36.1	28.9
S.D.	16.6	20.7	13.2	10.1	6.6

* Before Irradiation

Taurina levels reach a peak at 24 hours and return to normal values at 48 hours. After 72 hours, taurina levels decrease below control values.

The increase during the first 48 hours postirradiation taken in percentage of controls were plotted against doses and a linear correlation was found (fig. 1).

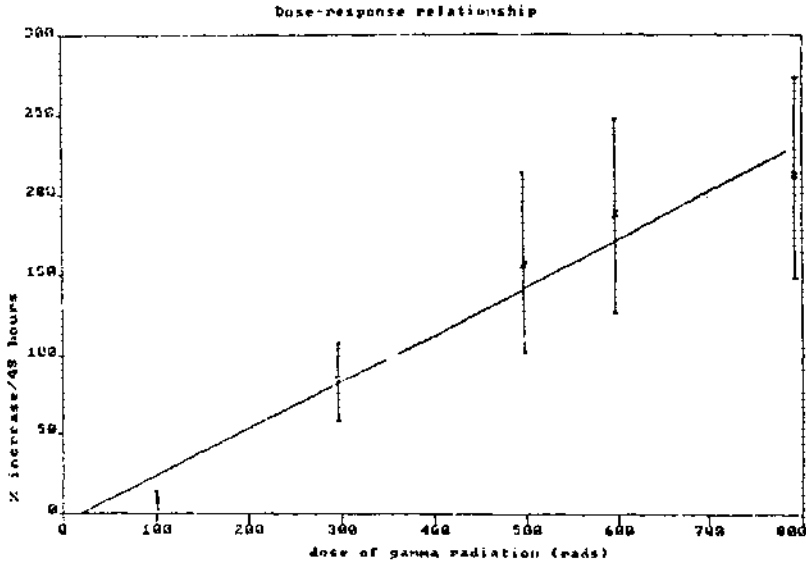

Each point is the average of at least 4 rats.

DISCUSSION:

A number of studies have shown an enhancement in the urinary excretion of taurine after accidental exposures and in irradiated rats and mice.

The present results confirm that increase and the existence of a linear relationship up to a dose of 800 cGy. The lower limit of dose detection is restricted to 100 cGy.

However, the values obtained are not in agreement with the findings of Raghavan and Nadkarni showing a persistence of high taurine levels after 72 hours of high dose irradiation. We have found a decrease of the mean values in irradiated samples below of control ones, at that time.

It may be questioned the validity of this assay pointing out the relatively great fluctuation in the "normal" physiological taurine status in urine and plasma, but this level is restored after 48-72 hours postirradiation and can be estimated for each individual.

The technique used provides accurate and precise quantitation of taurine in biological materials within 70 minutes.

The level of urinary taurine may be useful for high dose ranges in the early evaluation of radiation injury.

REFERENCES:

- 1- Raghavan, K. G., Int. J. Radiat. Biol., 1970, 18 (41-49)
- 2- Márquez, F. J., J. Chromatogr., 1986, 380 (275-283)
- 3- Larsen, B. J. Chromatogr. Sci., 1980, 18 (233-236)

RESPONSES OF GAMMA IRRADIATED MICE TO α -TOCOPHEROL

N. M. Eliosoff, D. Dubner and P. Gisone

Comisión Nacional de Energía Atómica
Gerencia de Seguridad Radiológica y Nuclear
Buenos Aires. Argentina

ABSTRACT

CB57 female mice whole body gamma irradiated were orally administered with acetato DL- α -tocopherol. It was observed a higher survival in α -tocopherol treated groups up to 14th and 10th days with doses of 8.5 and 10 Gy respectively and a greater bone marrow cellularity at day 10 in α -tocopherol treated group irradiated with 10 Gy.

INTRODUCTION

Radiation-induced damage to biological membranes is important because these cellular elements perform a decisive role in the functional organization of the cell. In view of the importance of α -tocopherol in membrane structure, we chose this drug to test its action not only in protecting against initial radiation damage but also in the recovery from radiation stress.

Rejholcová and als. (1) found an increase in lipid peroxidation from the 13th postirradiation day after doses of 6.8 Gy. They suggested this peroxidation was the result of metabolic disorganization caused by the radiation sickness.

In this work we used higher doses of radiation (8.5' and 10 Gy) and assuming that increase in lipid peroxidation could be observed earlier, the α -tocopherol was administered to mice immediately after exposure and 4 and 7 days later.

MATERIAL AND METHODS

CB57 female mice, 8 weeks old, weighing 18-20g were whole body gamma irradiated with doses of Co-60 (8.5-10 Gy, dose rate 0.25 Gy/min).

Acetato DL- α -tocopherol (50mg/kg body weight) using corn oil as carrier was orally administered to mice immediately after exposure and 4 and 7 days later. Animals treated with only corn oil served as control.

Damage was assessed using mortality as endpoint. Animals were observed daily from the first day following irradiation. A group was sacrificed at different times, and the other one when terminally moribund. Splenic weight and bone marrow and splenic cellularity were evaluated at different times (3-8-16-23 and 30 days). Body weight was daily monitored.

Data represent mean values obtained from 4 separate experiments and were analysed using Student t test.

RESULTS

Survival data are summarized in Table 1.

SURVIVAL

TABLE 1

day	DOSE = 8.5 Gy		DOSE = 10 Gy	
	α -tocopherol	control	α -tocopherol	control
0	100.0%	100.0%	100.0%	100.0%
7	97.6%	85.4%	100.0%	84.2%
10	84.6%	81.1%	100.0%	52.9%
14	81.1%	57.1%	11.8%	0.0%
30	21.2%	32.2%	0.0%	

The α -tocopherol and control groups irradiated with 8.5 Gy showed a significant mortality by the 30 day, but up to 14th day α -tocopherol treated group had greater survival than control one. Although a dose of 10 Gy resulted in 100% lethality of treated and control animals by day 15 after irradiation, treated group had a significantly higher survival than control one up to 10th day.

The body weight was decreased by about 20% on day 2 postirradiation in treated and control groups irradiated with 8.5 Gy. The growth recovered to the normal level by 30 days (fig. 1). Animals irradiated with 10 Gy did not reach normal weight until the end of the experience. Although the values are not significant, body weight in α -tocopherol treated group tended to be greater than control one (fig. 2).

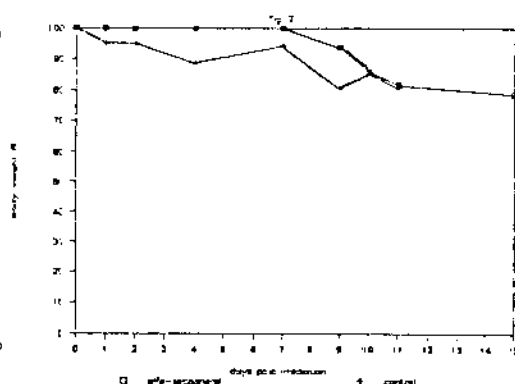
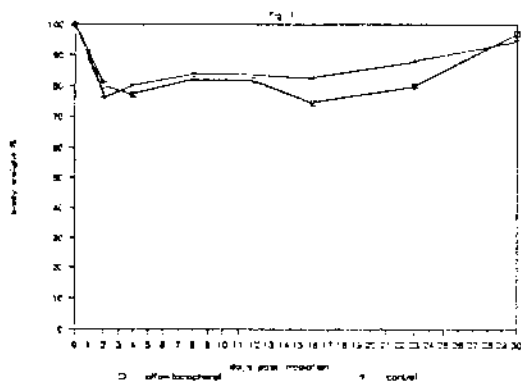

Relative to normal (nonirradiated mice) the splenic weight of 8.5 Gy irradiated animals was reduced to \approx 30% at day 3 postirradiation and so on up to day 20, when it was observed an overshoot. Thirty days were needed for recovery to the control level (fig.3). A similar initial fall was observed in mice irradiated with 10 Gy. The splenic weight in α -tocopherol treated group tended to increase showing a

significant difference on day 12 ($p < 0.01$). The splenic hyperplasia and the recovery to normal level could not be observed because of the earlier death (fig. 4).

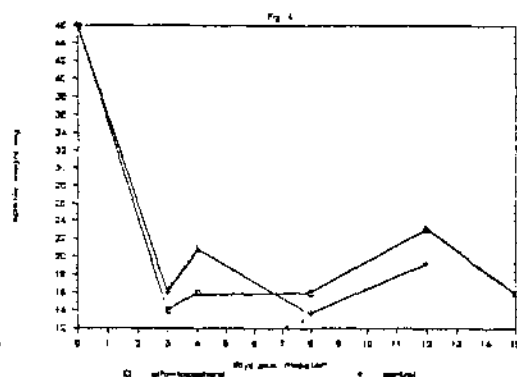
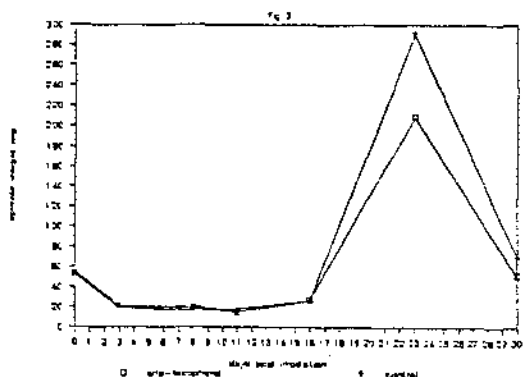

The bone marrow cellularity of both irradiated groups (8.5 Gy) reached minimal values (about 1.5% of the nonirradiated mice) on day 3, and tended to recover on day 12. The complete recovery was reached on day 30 (fig. 5). Bone marrow cellularity of both irradiated groups (10Gy) decreased significantly to 0.7% on day 4, and turned to increase thereafter, but finally the recovery failed. However, mice treated with α -tocopherol exhibited increased bone marrow cellularity at day 10 postirradiation relative to control group (fig. 6).

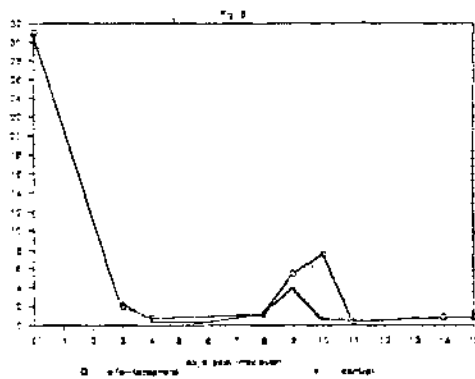
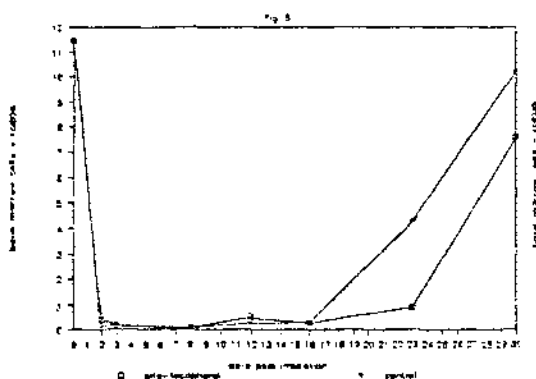

Qualitatively splenic cellularity was similar to bone marrow cell counts. However in groups irradiated with 8.5 Gy it was observed a very significant increase on day 20 postirradiation, reaching normal values on day 30, accordingly to splenic weight.

DISCUSSION

Although radiation lethality does not seem to be greatly affected by the oral intake of α -tocopherol after irradiation our results show a greater survival in α -tocopherol treated groups up to 14th day and up to 10th day with doses of 8.5 and 10 Gy respectively.

After total body irradiation at low doses death from hematopoietic depletion continues beyond 10 day, and is complete by 15 days, while death from gut failure occurs by day 10 at high doses.

Analysis of our data would suggest a probable radioprotector role of α -tocopherol on bone marrow syndrome. With doses of 8.5 Gy, the differences between bone marrow and splenic cellularity in α -tocopherol and control groups were not significant, but the survival of α -tocopherol treated group was higher than control one up to 14th day. In animals irradiated with doses of 10 Gy, it was observed not only a higher survival up to 10th day, but also bone marrow cellularity was greater in α -tocopherol treated group respect to control one. Alfa-tocopherol administered after irradiation would help animals exposed to recover from radiation damage, decreasing lipid peroxidation events. It is suggested these events are the result of a late metabolic disorganization caused by the radiation sickness.

Although our data are not concluding they show a trend to a radioprotector role. There would be different explanations for these not concluding results: 1) Alfa-tocopherol contained in corn oil (1mg/g corn oil, Rowe and Wills, (2)) could play certain radioprotective action, explaining why there were not significant differences in animal survival and bone marrow cellular counts with doses of 8.5 Gy. 2) The days chosen for the reinforcement doses of α -tocopherol probably were not accord to a 10 Gy dose of radiation, being the plasmatic levels of α -tocopherol not sufficient to prevent secondary lipid peroxidation events. 3) Alfa-tocopherol treated group irradiated with 10 Gy had higher survival and bone marrow cellularity at day 10. However, this dose resulted in 100% lethality by day 15. It could be suggested that this mortality is caused by gastrointestinal damage rather than bone marrow failure. It seems that α -tocopherol would prevent death from bone marrow depletion but not from gastrointestinal injury.

REFERENCES:

- 1- Rejholcová, M. and Wilhelm, J., Rad. Research, 117:21-25 (1989)
- 2- Rowel, L. and Wills, E. D., Biochem. Pharmac., 25: 175-179 (1976)

CYTOGENETICAL EVALUATION OF A NEW ANIMAL MODEL
FOR RADIOBIOLOGICAL STUDIES

Nasazzi, N.; Taja, M.R.; Nagle, C.*; Giménez, J.C.
Comisión Nacional de Energía Atómica
Centro de Educación Médica e Investigaciones Clínicas*
Buenos Aires - Argentina

SUMMARY

The response of a New World monkey species (*Cebus apella paraguayanus*) lymphocytes to various doses of 60 Co gamma-rays has been studied using dicentric + rings frequency in first mitosis and compared to that of man. Results have shown that differences between both species are no significant. The distribution of 200 breakpoints in G-banded metaphases has been scored showing an excess of breaks in chromosomes 1, 11, 12 and 16. Terminal heterochromatic blocks differ from intercalary heterochromatin in the response to gamma radiation being the former more affected.

INTRODUCTION

Frequency of accidental whole-body overexposures is low even though they may result in lethal effects. For that reason, present knowledge for diagnosis and treatment of such overexposures is scanty and it is necessary to extrapolate qualitative and quantitative data from animal models used to reproduce accidental overexposure conditions. To extrapolate with confidence, an adequate animal model should have a close phylogenetical relationship and show radiosensitivity similar to that of man.

Among New World Monkeys, *Cebus apella paraguayanus* (Fisher, 1829) is one of the most widely spread species in South America and frequently used in biomedical research. This species has shown a successful breeding and reproduction rate in captivity. Its karyotype has been standardized (1) and the amounts and variations of constitutive heterochromatin have been characterized (2). Among Platyrrhini, this species is the least distant to man, with about thirty five rearrangements separating both karyotypes (3). However, previous studies have shown that phylogenetical proximity does not necessarily imply a similar radiosensitivity because even the higher primates such as gorilla and chimpanzee (4) don't represent good models, at least for quantitative estimation of cytogenetical hazards, because chromosomal radiosensitivity is not related to chromosome number, chromosome arm number or similarities in the karyotypes (5) even if only first mitoses are considered.

Unstable chromosome aberrations frequency in short-term lymphocytes cultures is a useful tool to make direct analysis of the effects of ionizing radiation on human and other species genetic material using in-vitro irradiations or samples from in-vivo overexposures.

In order to establish if *Cebus apella paraguayanus* has a chromosomal radiosensitivity similar to that of man we have estimated the frequency of unstable chromosomal aberrations (dicentric+rings/cell) in 48 hours lymphocytes cultures of

both species, using simultaneously in-vitro irradiated human and primate blood samples with different doses of ^{60}Co gamma-radiation, from 0.5 Gy to dosimeter saturation point. Distribution of the breakpoints among the chromosomes involved in the production of dicentrics and rings has been scored in G-banded metaphases.

MATERIAL AND METHODS

Three human and three *Cebus apella paraguayanus* whole blood samples have been irradiated by gamma-rays at high dose-rate from a ^{60}Co source, pairing a human and a monkey sample in each irradiation at 0.5, 1, 2, 3, 5 and 6 Gy doses. Whole-blood cultures have been immediately set-up using RPMI 1640 medium with 1-2 % PHA and supplemented with FCS (15 %). Cells have been harvested after 48 hours. At this time practically 99 % and more than 95 % of human and monkey (own data) lymphocytes respectively are in first division. Irradiations at 7 Gy in both species indicate dosimeter saturation ($y:2\text{ dic}+r/\text{cell}$). For that reason the higher dose considered in data analysis has been 6 Gy. A blood sample of *Cebus apella* has been irradiated at 2 Gy and 300 well spread metaphases from 48 hours cultures were used to localize breakpoints on G-banded chromosomes following the procedure of Seabright, 1971 (6).

RESULTS

Human results have been fitted to a linear quadratic dose-effect model, using least squares weighted method (weight: $1/y$) obtaining values of $2.613\text{ E-}02 \pm 0.01$ and $5.074\text{ E-}02 \pm 0.004$ for α and β coefficients respectively (χ^2 : $2.35\text{ E-}02$; DF:4). (TABLE I)

Cebus apella results have been fitted to a quadratic dose-effect model with β coefficient: $5.575\text{ E-}02 \pm 0.01$ (χ^2 : $2.25\text{ E-}02$; DF:5) (Fig. I). Background levels have been discounted from y values in each dose and in both species. The two way analysis of variance indicates that there is no significant difference between species or for interaction dose-species ($p > 0.05$).

A total of 100 two-breaks chromosome aberrations (dicentrics + rings) were scored in 300 G-banded karyotypes prepared from gamma irradiated at 2 Gy cells of 48 hs culture. The distribution of the observed number of breakpoints per chromosome and comparison with the expected numbers is presented in Table II. The expected numbers has been calculated assuming that break distribution is proportional to chromosome corrected length in 54,XY cells, taking into account C-bands heteromorphisms for 11 and 19 chromosome pairs. This specimen shows the following heterochromatic variations: Pair 11: one chromosome (11L) with a large-size terminal block (85% of the chromosome length) and the other (11M) with a medium-size block (75% of the chromosome length). Pair 19: one chromosome (19H) with an intercalary heterochromatic block (40% of the chromosome length) and the other without it.

The differences between the observed and expected number of breakpoints per chromosome, determined by χ^2 analysis,

are shown in Fig. II. As can be seen, chromosomes 1, 12 and 16 show significant excess of breakpoints ($p < 0.01$). A trend toward a deficiency of breaks has been observed in chromosome 4 ($p < 0.1$) and to an excess of breaks in chromosome 11 L ($p < 0.1$) and 11 M ($p < 0.05$).

DISCUSSION

Even though each species fits to different models the results of analysis of variance indicate that differences are not significant. Under the light of this data this species could be considered a model in terms of cytogenetical evaluation, at least in the range from 0.5Gy to 6Gy. However, being ratio α/β approximately 0.5 Gy for man, the authors think this model deserves further studies under this low dose, to focalize the precise behavior of monkey chromosomes in the zone where it is postulated that dicentrics are produced principally by one track.

Respecting distribution of breakpoints, the results have indicated that chromosomes 1, 12 and 16 have been more frequently involved in radiation induced aberrations but they have shown random association with the second chromosome which takes part in each aberration. Interestingly, conspicuous terminal heterochromatic blocks in chromosomes 11 have shown more breaks than expected resembling chimpanzee terminal heterochromatin behavior (7), though this species seems to be more radiosensitive than man, contrary to *Cebus apella paraguayanus*. However, in the case of chromosome 19 H, clustered breaks in euchromatin but none in the intercalary heterochromatic block has been observed. If the amount and position of heterochromatin play some role and must be taken into account when chromosome radiosensitivity of a particular species is evaluated, requires more information.

REFERENCES

- 1.- Matayoshi, T.; Howlin, E.; Nasazzi, N. et al. Chromosome studies of *Cebus apella*: The Standard Karyotype of *Cebus apella paraguayanus*, Fisher, 1829. *Am. J. Primatol.* 10:185-193 (1986)
- 2.- Matayoshi, T.; Seuánez, H.; Nasazzi, N. et al. Heterochromatic variation in *Cebus apella* (Cebidae, Platyrrhini) of different geographic regions. *Cytogenet. Cell Genet.* 44:158-162 (1987)
- 3.- Dutrillaux, B.; Muleris, M.; Paravatou-Petsota, M. Diagrammatic representation for chromosomal mutagenesis studies: Karyotypes most similar to that of man. *Mut. Res.*, 126:81-92 (1984)
- 4.- Léonard, A.; Decat, G.; L. Fabry The lymphocytes of small mammals A model for research in cytogenetics? *Mut. Res.*, 95:31-44 (1982)
- 5.- Léonard, A.; Fabry, L.; Deknuddt, G. and G. Decat. Chromosome aberrations as a measure of mutagenesis. Cytogenetic extrapolation from animal to man. *Cytogenet. Cell Genet.* 33:107-113. (1982)
- 6.- Seabright, M. A rapid banding technique for human chromosomes. *The Lancet* 2:971-972. (1971)
- 7.- Paravatou-Petsota, M.; Muleris, M.; Prieur, M. and B. Dutrillaux. Diagrammatic representation for chromosomal mutagenesis studies. III Radiation-induced rearrangements in *Pan troglodytes* (chimpanzee). *Mut. Res.*, 149:57-66. (1985)

TABLE I

DOSE (Gy)	MAN			CEBUS		
	Cells scored	Dic+ring	Frequency	Cells scored	Dic+ring	Frequency
0.5	501	18	0.035	500	14	0.028
	500	13	0.026	500	20	0.040
	500	10	0.020	500	18	0.036
1	300	18	0.060	311	7	0.022
	252	26	0.073	500	30	0.060
	315	21	0.066	500	22	0.044
2	203	56	0.275	200	46	0.230
	250	56	0.224	245	45	0.306
	200	60	0.300	200	82	0.410
3	200	116	0.580	200	86	0.430
	200	123	0.615	200	108	0.540
	200	100	0.500	200	98	0.490
5	100	142	1.420	96	171	1.260
	100	153	1.530	60	95	1.583
	100	152	1.520	75	110	1.466
6	67	125	2.016	50	108	2.160
	100	190	1.920	95	180	1.894
	00	193	1.930	50	110	2.360

TABLE II Distribution of breaks per chromosome

Chromosome	Observed	Expected
1	27	12
2	7	11.04
3	10	9.98
4	2	9.28
5	6	8.70
6	9	8.26
7	5	7.16
8	4	6.20
9	2	4.48
10	3	4.48
11 L	15	7.08
11 H	10	4.89
12	17	4.84
13	8	8.84
14	5	6.52
15	4	8.32
16	14	7.60
17	11	7.50
18	6	7.00
19	4	2.50
19 H	5	4.94
20	5	5.74
21	4	4.76
22	2	4.62
23	2	4.48
24	3	3.84
25	2	3.04
26	1	3.04
X	6	8.92
Y	1	2.44

Fig. 1: Gamma radiation dose-response relationship

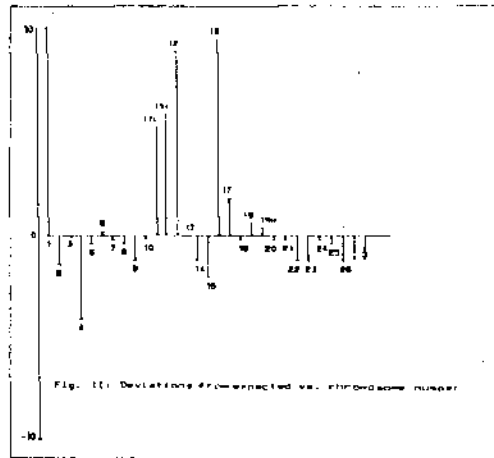
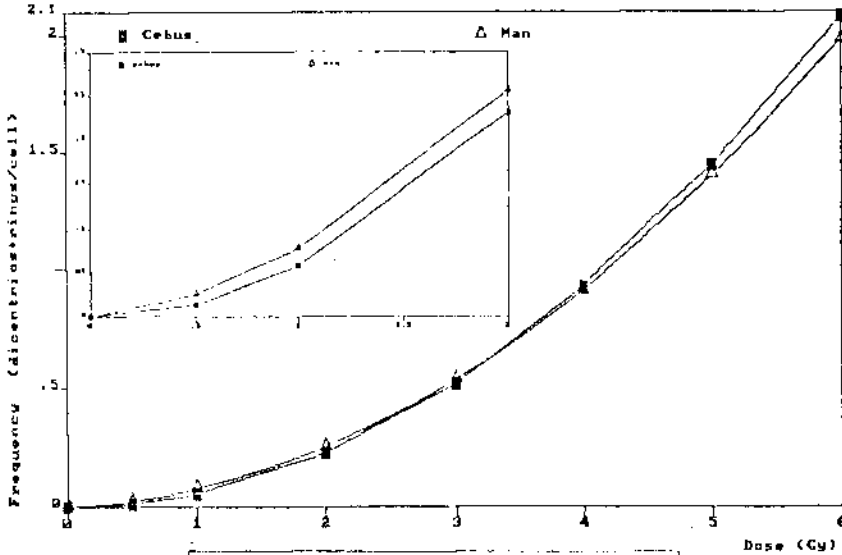

Fig. 2: Deviations from expected vs. chromosome number

The Effect of Dose Protraction on the Incidence of Lung Carcinomas in Beagle Dogs with Internally Deposited β -Emitting Radionuclides

W.C. Griffith, B.B. Boecker, F.F. Hahn, B.A. Muggenburg, and M.B. Snipes
Inhalation Toxicology Research Institute, PO Box 5890, Albuquerque NM 87185 USA

ABSTRACT: Studies using Beagle dogs were conducted to understand health effects when lung is the primary organ irradiated after inhaling insoluble radioactive particles containing one of four β -emitting radionuclides, ^{90}Y , ^{91}Y , ^{144}Ce , or ^{90}Sr . The low-LET β irradiation was delivered over a wide range of total doses and dose rate patterns that protracted the dose to lung from about 1 wk to several years. The tumor incidence rates for lung carcinomas were estimated using a proportional hazard rate model. These studies suggest that dose protraction only affects production of lung carcinomas at doses above 50 Gy.

INTRODUCTION: Studies using Beagle dogs were conducted to understand the health effects of inhaling radioactive particles when lung is the primary organ irradiated. Our studies were designed to complement the limited information available from human epidemiological studies. In this report, we present our analysis of four, β -emitting radionuclides, ^{90}Y , ^{91}Y , ^{144}Ce , or ^{90}Sr , acutely inhaled as relatively insoluble particles by young-adult dogs^(1,2). This aerosol form resulted in the radiation dose being delivered primarily to lung and adjacent tissues. These studies examined the health effects of exposure to low-LET β irradiation over a wide range of total doses and dose rates. The dose-rate patterns are characterized by a decreasing dose rates due to radioactive decay and clearance of particles from the lung. These patterns protracted the dose from a single inhalation exposure from about 1 wk to several years and are more similar to occupational and environmental exposures than are exposures that were received by the subjects of human epidemiology studies exposed to low-LET radiation from which regulatory limits for exposure have been developed. The exposures in the latter category were either a single, high-dose-rate exposure for the Japanese atomic bomb survivors or a series of high-dose-rate exposures for medically exposed patients, such as ankylosing spondylitis patients.

The importance of dose rate for low-LET exposures is difficult to resolve. Because of the lack of data, the effect of dose protraction has usually been summarized into a simple dose-rate-effectiveness factor that divides the cancer risk factors for low-LET radiation exposures at high dose rates. The BEIR V committee⁽³⁾ did not specifically recommend a number for this factor, because of the scarcity of data, but thought that it must be at least 2. These studies are the first to study the effect of dose-rate protraction for low-LET radiation exposure in lifespan studies, using a long-lived laboratory animal species.

METHODS: Predicting cancer risks for people by extrapolating from carcinogenesis studies using animals as subjects is a largely empirical process, because the present knowledge of the mechanisms of carcinogenesis is inadequate. This report is a summary of our studies of incidence rates of β -irradiation-induced lung carcinomas by means of a relative risk function. The relative risk function relates tumor incidence rate to both total dose and dose pattern. Similar methods are used to summarize carcinogenesis information from studies of human populations exposed to low-LET external radiation⁽³⁾.

We applied proportional hazard rate models to describe how tumor incidence rates change with radiation dose⁽⁴⁾. To describe these models, suppose that $X(t)$ is a time-dependent covariate vector where the tumor incidence rate is proportional to the baseline tumor incidence rate at $X(t) = 0$; that is

$$\lambda(t, X(t)) = \lambda(t, 0)\Theta(X(t)),$$

where $\Theta(X(t))$ is the relative risk function at $X(t)$. In this model, the estimated lung tumor incidence at 0 dose $\lambda(t, 0)$, is multiplied by the relative risk function $\Theta(X(t))$. All animals in these four studies were used to estimate both $\lambda(t, 0)$ and $\Theta(X(t))$. The multiplicative factor $\Theta(X(t))$ is the relative risk (i.e., relative to values of the covariates where $\Theta(\cdot) = 1$) and is only related to time through the covariates. No assumption about the function $\lambda(t, 0)$ is made, and thus, inference does not depend upon a particular shape or form of a mathematical relationship being satisfied. Estimation of the relative risk function $\Theta(X(t))$ is of main interest, because it summarizes the effect of the radiation dose. In this report we used an additive form of the relative risk $\Theta(X(t)) = 1 + \beta X(t)$ where β is a vector of coefficients to be estimated. Estimates of β were found by maximizing the partial likelihood with a Newton-Raphson technique, and the covariance matrix for these estimates was found by inverting the observed information matrix⁽⁵⁾.

Lung carcinomas were the primary biological endpoint of interest for this paper. Lung carcinomas were diagnosed on the basis of radiographic, autopsy, and histopathologic information. Time to lung carcinoma was taken as the time to the first positive radiograph, or to death, if there were no positive radiographs. Animals without detected lung tumors were treated as being censored at their death time.

RESULTS: A common baseline incidence rate function $\lambda(t, 0)$ for lung carcinomas was used for the four studies so that the relative risk function would be comparable for the four radionuclides. This was a reasonable assumption because all the dogs were produced in the Institute's animal colony using a randomized breeding program. Radiation doses to the lung were calculated as average absorbed β doses in Gy using the coefficients shown in Table 1 and estimating the lung weight including blood, to be 1.1% of the total body weight at time of exposure. The shifts in time to appearance of lung tumors make it possible to model these studies. If the time to appearance of the tumors were not considered, the numbers of animals and tumors would be too small to model in the same detail as has been possible using this information.

Table 1
Basic Dosimetric Parameters for Radionuclides Inhaled in
Fused Aluminosilicate Particles by Beagle Dogs.

	⁹⁰ Y	⁹¹ Y	¹⁴⁴ Ce	⁹⁰ Sr
Average β energy (MeV)	0.93	0.60	1.29	1.13
Radionuclide half-life (days)	2.7	59	284	10,600
Lung retention half-life (days)	2.5	50	175	154 (39.5%) 990 (60.5%)
Time to accumulate 95% of total committed dose (days)	11	220	760	3600

The parametric form of the relative risk $\Theta(\cdot)$ found to describe these studies best was a linear function of dose added to a power function of dose having the following form :

$$1 + \sum_{i \in A} [\exp(\alpha) d_i(t) + \exp(\beta_i) d_i^{\gamma_i}(t)],$$

where $A = \{^{90}\text{Y}, ^{91}\text{Y}, ^{144}\text{Ce}, ^{90}\text{Sr}\}$, $d_i(t)$ are time-dependent doses in Gy, and $\alpha, \beta_i, \gamma_i$ are estimated coefficients. The time-dependent dose functions $d_i(t)$ are non-zero only for animals exposed to radionuclide i . The maximum partial likelihood estimates for the coefficients are shown in Table 2 and the excess relative risk (1 subtracted from the relative risk) in Figure 1. By the likelihood ratio test, this model was a statistically significant improvement ($p < 0.01$) over models with just a linear function of dose or just a power function of dose (analysis not shown), but there was no statistically significant improvement ($p > 0.2$) to estimate separate linear coefficients, α_i , for each radionuclide.

Table 2
Estimates of Coefficients and Their Standard Errors for the Relative Risk Model Outlined in the Text with the Linear Coefficient $\alpha = -2.9(0.6)$ for All Four Radionuclides.

Coefficient	^{90}Y	^{91}Y	^{144}Ce	^{90}Sr
β	-39.7 (11.9)	-36.3 (6.3)	-25.0 (6.7)	-10.3 (3.6)
γ	10.2 (2.8)	8.3 (1.2)	5.3 (1.1)	2.8 (0.6)

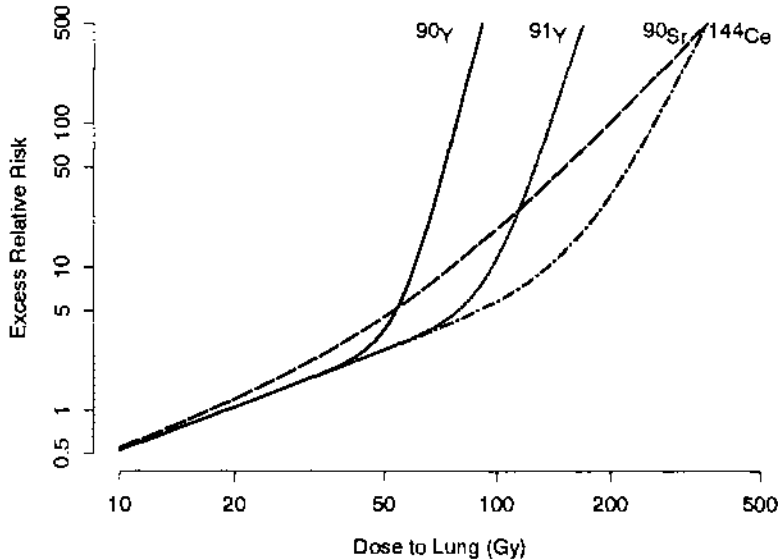

Figure 1: Excess relative risk (1 subtracted from the relative risk) for development of lung carcinoma in Beagle dogs as a function of radiation dose to the lung.

DISCUSSION: The models used in this report relate the lung carcinoma incidence rates to two factors: 1) the cumulative radiation dose in Gy as a time-dependent quantity and 2) the pattern of accumulation of the radiation dose, by estimating separate

coefficients for each of the four radionuclides used in the studies. Because the physical half-lives of the radionuclides differed, the patterns of dose delivery differed greatly. The estimated coefficients for the four radionuclides also differ from each other, indicating that the characteristics of the exposure pattern, in addition to the time-dependent dose, are important to estimate the risks of developing lung carcinomas. In the case of dose protraction, the radionuclide dose is delivered at a constantly changing dose rate. Thus, a dog with a high initial dose rate will experience a constantly decreasing dose rate until death. This means that the pattern of dose protraction used in these studies does not have a simple relationship to any single dose rate.

The results of this analysis indicate that the effect of dose protraction on the incidence of lung carcinomas is similar at the lower range of doses used in this study but differs markedly at high doses (Figure 1). At high doses, it is much more effective to deliver the dose over a short time period. Within the power of this study, it was not possible to discern a difference between the four radionuclides below about 50 Gy. This suggests that there may not be an effect of dose rate on the production of lung carcinomas below doses in this range.

ACKNOWLEDGEMENTS: *Research sponsored by U.S. DOE/OHER, under Contract No. DE-AC04-76EV01013 and was performed in facilities fully accredited by the American Association for the Accreditation of Laboratory Animal Care.*

REFERENCES

1. Hahn, F.F., Boecker, B.B., Cuddihy, R.G., Hobbs, C.H., McClellan, R.O., and Snipes, M.B., 1983, Influence of Dose Rate Patterns on Lung Tumor Incidence in Dogs That Inhaled Beta Emitters: A Preliminary Report, *Radiation Research* 96, 505-517.
2. Inhalation Toxicology Research Institute, 1991, *Annual Report on Long-Term Dose-Response Studies of Inhaled or Injected Radionuclides: 1989-1990* (B. B. Boecker, B.A. Muggenburg, S.C. Miller, P. L. Bradley, eds.), LMF-130, National Technical Information Service, Springfield, VA.
3. National Academy of Science, 1990, *BEIR V : Health Effects of Exposure to Low Levels of Ionizing Radiation*, National Academy Press, Washington D.C.
4. Cox, D.R., and Oakes, D., 1984, *Analysis of Survival Data*, Chapman and Hall, London.
5. Kalbfleisch, J.D. and Prentice, R.L., 1980, *The Statistical Analysis of Failure Time Data*, Wiley, New York.

THE EFFECT OF ISOTOPE ON THE DOSIMETRY OF INHALED PLUTONIUM OXIDE

Raymond A. Guilmette¹, Albert W. Hickman² and William C. Griffith¹

1. Inhalation Toxicology Research Institute, P. O. Box 5890, Albuquerque, NM 87185

2. University of Florida, Gainesville FL

ABSTRACT: Results of experimental studies in which animals inhaled $^{238}\text{PuO}_2$ or $^{239}\text{PuO}_2$ aerosols have shown that the biokinetics and associated radiation dose patterns for these two isotopes differ significantly due to differences in *in-vivo* solubility caused by the 260-fold difference in specific activity between $^{238}\text{PuO}_2$ and $^{239}\text{PuO}_2$. We have adapted a biokinetics and dosimetry model derived from results of the ITRI dog studies to humans and have calculated dose commitments and annual limits on intake (ALI) for both Pu isotopes. Our results show that the ALI calculated in this study is one-third that for class Y ^{238}Pu from ICRP 30, and one-half or equal to that for class Y ^{239}Pu , depending on how activity in the thoracic lymph nodes is treated dosimetrically.

INTRODUCTION: Inhalation has been shown to be the most likely route of occupational exposure to plutonium. Nonoccupational inhalation exposures to Pu aerosols have also occurred as a result of atmospheric nuclear weapons testing. Despite these exposures, information from studies of people have not been adequate to define the dosimetry of inhaled Pu aerosols. Consequently, data from experiments with animals are used to augment our knowledge of Pu biokinetics and dosimetry and to identify important dose- and effect-modifying factors. This report summarizes results obtained from studies at ITRI in which adult dogs inhaled monodisperse aerosols of either $^{238}\text{PuO}_2$ or $^{239}\text{PuO}_2$ having similar aerodynamic sizes, produced in the same way, and having the same chemical form. Therefore, the two exposure materials differed only in specific activity.

MATERIALS AND METHODS: The materials and methods used in these studies have been reported in detail (1,2). Briefly, adult male and female beagle dogs (15 - 41 mo of age) received a single brief pernasal inhalation exposure to a monodisperse aerosol of $^{238}\text{PuO}_2$ (1.7 or 2.7 μm AMAD) or $^{239}\text{PuO}_2$ (1.4 or 2.9 μm AMAD). Each aerosol was produced by heat-treating droplets of a nebulized suspension of $\text{Pu}(\text{OH})_4$ at 1150°C, thus forming PuO_2 . After exposure, each animal was maintained in a metabolism cage for excreta collection and in a kennel run until the dog was either sacrificed, euthanized or died. Sacrifice times ranged from 4 hr to 4 y after exposure. Additional data from dogs that inhaled $^{239}\text{PuO}_2$ as part of a dose-response study were also included in this analysis (3). Radiochemical analysis of Pu in tissue and excreta samples provided the data for determination of the biokinetics of ^{238}Pu and ^{239}Pu following inhalation deposition of Pu in oxide form.

Fifty-year dose commitments for lung, liver and bone surfaces of humans were obtained from different models for ^{238}Pu and ^{239}Pu . In the former case, the doses were calculated using the canine-based model of Mewhinney and Diel (1) that was modified for application to man. Four changes in metabolic parameters from those of the canine model were made: 1) The partitioning of Pu that reached the blood from solubilization of the deposited Pu particles was 45% liver, 45% bone, 4% muscle and 0.4% kidney, values which were derived from the analyses of McInroy *et al.* (4),

and are similar to those suggested in ICRP 30 (5). 2) A ratio of Pu in urine to Pu in feces of 1 was used based on the systemic model of Leggett (6). 3) Biological retention half times of 40 y for liver and 100 y for skeleton, as proposed in ICRP 30 (5) and supported by analyses of exposed humans (7) were used. 4) The particle size of the inhaled aerosol was assumed to be 1.0 μm diameter.

The calculation of human dose commitments for ^{239}Pu was based on retention equations obtained from the ITRI dog studies modified to include the 40-y biological half time for liver and 100-y half time for skeleton. These equations are:

$$R_{lung}(t) = 0.18e^{-0.024t} + 0.82e^{-0.00045t}$$

$$R_{liv}(t) = 0.010e^{-4.7 \times 10^{-5}t}(1 - e^{-0.12t})$$

$$R_{skel}(t) = 0.0017e^{-1.9 \times 10^{-5}t}(1 - e^{-0.12t})$$

$$R_{thor}(t) = 0.17e^{-0.027t} + 0.83e^{-0.00016t}$$

where $R_i(t)$ is the retention in organ i (where i = lung, liver, skeleton and thoracic = lung + lung-associated lymph nodes, LALN, respectively) expressed as fraction of the initial lung burden, and time t is in days after exposure. For all dose calculations, the organ masses used were those specified in ICRP 30 (5), i.e. lung = 1000 g, liver = 1800 g, and bone surfaces = 120 g.

RESULTS AND DISCUSSION: Model curves describing the retention of ^{238}Pu and ^{239}Pu in dogs exposed to PuO_2 aerosols are shown in Figure 1 for lung and skeleton. The retention of Pu in liver (not shown) was similar to that in skeleton. The biokinetics of the two Pu isotopes were significantly different. Whereas ^{239}Pu was retained in lung and LALN for very long times, ^{238}Pu translocated from the lung mainly to liver and bone at an accelerated rate beginning at about 100 days after exposure. The accumulation of ^{238}Pu in liver and bone was about 200 times larger than that seen with ^{239}Pu .

The observed difference in biokinetics of inhaled ^{238}Pu and ^{239}Pu aerosols has been explained based on the 260-fold difference in specific activity of equivalently sized aerosol particles. The much higher specific-activity $^{238}\text{PuO}_2$ particles incur a proportionately higher amount of energy deposition within the particle itself, particularly from the recoil nuclei. This energy deposition results in damage to the crystalline structure of the PuO_2 , presumably lattice defects that accumulate with time, and that ultimately are expressed in an aqueous environment as fragmentation and accelerated dissolution (8). This theory is supported by autoradiographic observation of particle breakup (8). The dissolved ^{238}Pu was then available for translocation to blood and redistribution to the major deposition sites for systemic Pu, i.e., liver and bone. In contrast, the much lower decay rate of ^{239}Pu has yet to provide concrete evidence that fragmentation of these particles occurs to any significant extent, at least through 3 y after exposure.

The consequences of the different radiation dose patterns found for the two Pu isotopes are shown in Table 1 with respect to the 50-y dose commitments predicted for man, as calculated using the ITRI models and using ICRP 30 methods (5). It can be seen for ^{238}Pu that the highest dose commitments were to the bone surfaces for both methods of calculation, the difference being in the threefold higher dose

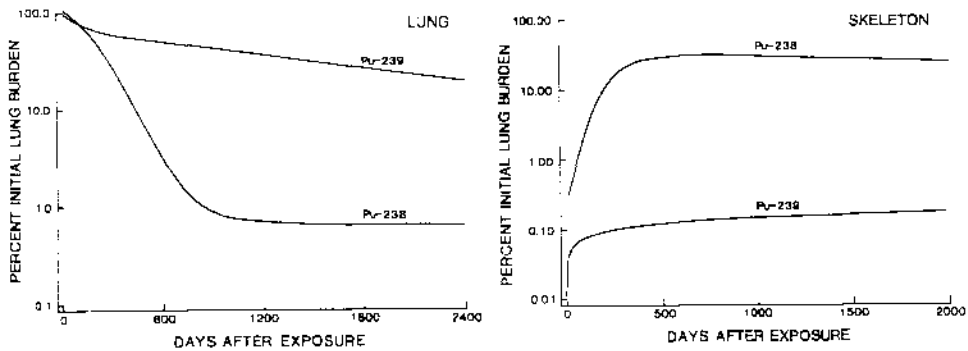

Figure 1: Model curves for the uptake and retention of ^{238}Pu and ^{239}Pu in lung and skeleton of dogs that inhaled Pu dioxide aerosols (data points for individual dogs not shown). Retention of Pu in liver was similar to those shown for skeleton.

Table 1
Dose Commitments for Inhaled ^{238}Pu and ^{239}Pu in Man (mSv/Bq inhaled)

Organ	^{238}Pu		^{239}Pu	
	This Report	ICRP 30	This Report	ICRP 30
Lung	0.079	---	0.65	---
Thoracic*	0.085	0.32	1.75	0.32
Liver	0.50	0.18	0.024	0.21
Bone Surface	2.4	0.83	0.019	0.95

* Includes Pu contained in lung and LALN, since ICRP 30 does not differentiate between activity in these two organs

derived from the ITRI model. This is due to the uptake of a larger fraction of inhaled ^{239}Pu that translocates to bone. For ^{239}Pu , there are several significant differences in the calculated dose commitments: 1) The dose to lung calculated with the ITRI model is either twofold or fivefold higher than that calculated using ICRP 30, depending on whether the activities translocated to the LALN are included in the dose calculation for the former. Although the rationale for including LALN activity with that of the lung as seen in the dog studies is speculative, there is evidence in human exposure cases that there is very long-term retention of insoluble Pu in the thoracic region (~6000 days based on thoracic photon measurement (9)), and the ratio of concentration of Pu in lung to that in lymph nodes is significantly larger in man than in dogs (10).

From Table 2, it is evident that the higher dose to bone surfaces for ^{238}Pu based on the ITRI model has resulted in a limiting ALI that is one third that of ICRP 30, i.e. 200 Bq vs. 600 Bq. For ^{239}Pu , the ITRI-derived ALI is either one half or equivalent to that of ICRP 30, depending on the manner in which the dose to lung is calculated. In either case, however, the limiting ALI for the ITRI model is determined by the stochastic ALI, of which most of the dose contribution comes from the dose to lung. This is more consistent with current data on the biokinetics and dosimetry of inhaled $^{239}\text{PuO}_2$ than is the ALI based on the nonstochastic dose to bone

Table 2
Annual Limits on Intake (Bq)

	Stochastic	Nonstochastic		
		Lung	Liver	Bone Surfaces
^{238}Pu				
This Study	450	6300	1000	200
ICRP 30	600	1600	2800	600
^{239}Pu				
This Study	240(630)*	290(770)*	14000	22000
ICRP 30	600	1600	2500	500

* ALIs in boldtype use dose commitments for lung and LANL; those in parentheses use lung only

surfaces. Whether reductions in the ALIs for Pu isotopes are warranted based on the available experimental data is a matter for discussion.

REFERENCES

1. Mewhinney, J.A., Diel, J.H. "Retention of inhaled $^{238}\text{PuO}_2$ in beagles: a mechanistic approach to description" *Health Phys.* 45, 39-60, 1983.
2. Guilmette, R.A., Diel, J.H., Muggenburg, B.A., Mewhinney, J.A., Boecker, B.B., McClellan, R.O. "Biokinetics of inhaled $^{239}\text{PuO}_2$ in the beagle dog: Effect of particle size" *Int. J. Radiat. Biol.* 45, 563-581, 1984.
3. Guilmette, R.A., Muggenburg, B.A., Hahn, F.F., Mewhinney, J.A., Seiler, F.A., Boecker, B.B., McClellan, R.O. "Dosimetry of ^{239}Pu in dogs that inhaled monodisperse aerosols of $^{239}\text{PuO}_2$ " *Radiat. Res.* 110, 199-218, 1987.
4. McInroy, J.F., Kathren, R.L., Swint, M.J. "Distribution of plutonium and americium in whole bodies donated to the United States Transuranium Registry" *Radiat. Protect. Dosim.* 26, 151-158, 1989.
5. International Commission on Radiological Protection, Limits on Intakes of Radionuclides by Workers, ICRP Publication 30, Pergamon Press, Oxford, England, 1979.
6. Leggett, R.W. "A model of the retention, translocation and excretion of systemic Pu" *Health Phys.* 49, 1115-1137, 1985.
7. McInroy, J.F., Kathren, R.L., Voelz, G.L., Swint, M.J. "U. S. transuranium report on the ^{239}Pu distribution in a human body" *Health Phys.* 60, 307-333, 1991.
8. Diel, J.H., Mewhinney, J.A. "Fragmentation of inhaled $^{239}\text{PuO}_2$ particles in lung" *Health Phys.* 44, 135-145, 1983
9. Carbaugh, E.H., Bihl, D.E., Sula, M.J. "Long-term follow-up of HAN-1, an acute plutonium oxide inhalation case" *Radiat. Protect. Dosim.* (in press)
10. Kathren, R.L., Strom, D.J., McInroy, J.F., Bistline, R.E. "Distribution of plutonium in the lungs and lymph nodes of USTR registrants and relationship to smoking status" *Health Phys.* 58, sup 1, S48, 1990

ACKNOWLEDGEMENTS: Work performed for the U. S. DOE/OHER under Contract No. DE-AC04-76EV01013 in facilities fully accredited by the American Association for the Accreditation of Laboratory Animal Care. A. W. Hickman's practicum at ITRI was supported by the DOE health physics fellowship program.

**EFFETS DE L'IRRADIATION GAMMA SUR LES CELLULES
MESENCEPHALIQUES ET STRIATALES EN CULTURE**

H. COFFIGNY*, M. BEAUVALLET*, L. COURT **

* Commissariat à l'Energie Atomique DSV/ DPTE/ STCE/ LRT
BP n°12 91680 Bruyères le Châtel France

** Centre de Recherche du Service de Santé des Armées, BP 87
F37702 La Tronche France

**GAMMA IRRADIATION EFFECTS ON MESENCEPHALIC AND STRIATAL
NERVE CELLS IN CULTURE**

ABSTRACT

Isolated rat mesencephalic and striatal nerve cells were gamma irradiated and cultured during 3 days. Significant increase mortality and neurite length reduction were observed with as little as 0.5 and 0.25 Gy respectively. The dopamine up-take in mesencephalic cells and the GABA up-take in cells of both structures were significantly decreased with 0.25 Gy and more deeply with higher doses. This study gave a threshold value with functions of living cells as target and established dose-effect relationships.

INTRODUCTION

Des embryons et des fœtus humains âgés de 8 à 15 semaines exposés aux radiations émises lors des explosions d'Hiroshima et de Nagasaki présentaient une microcéphalie et des retards mentaux dans l'enfance et leur nombre augmentait avec les doses croissantes reçues (Otake and schull, 1984). Pour les faibles doses (inférieures à 0,5 Gy), le problème de l'existence d'un seuil est posé.

Pour aborder ce point, nous avons utilisé un modèle de cellules nerveuses de rat en culture. plus particulièrement, nous avons étudié les effets de l'irradiation sur les cellules mésencéphaliques, principalement les cellules de la substance noire, ainsi que sur les cellules du striatum (Coffigny and al., 1990). Ces deux structures sont en relation étroite sur le plan fonctionnel.

Trois paramètres sont étudiés sur ces cellules en culture:

- la mort des cellules nerveuses
- la croissance des neurites
- la capture de dopamine (DA) et d'acide gamma-amino-butyrique (GABA).

MATERIEL ET METHODES

La substance noire et le striatum sont prélevés sur des fœtus de rat à 14 jours de gestation. Les cellules nerveuses sont isolées mécaniquement par passages répétés dans une pipette Pasteur à bout rodé à la flamme. Dans une étude préparatoire, nous avons déterminé la concentration cellulaire à ensemercer. Elle est de $4 \cdot 10^4$ cellules/cm² pour mesurer la létalité cellulaire et la croissance des neurites et de $2 \cdot 10^5$ cellules/cm²

pour mesurer la capture de neurotransmetteurs.

Juste après la séparation, les cellules sont soit pseudo-irradiées soit irradiées avec une source de ^{60}Co aux doses de 0,25; 0,50; 0,75; 1,5 et 3 Gy. Elles sont alors mise en culture dans un milieu sans serum pendant trois jours. A ce stade, la survie des cellules nerveuses est estimée par l'exclusion du bleu trypan; le plus long prolongement "axonal" est mesuré sur des microphotographies des cultures cellulaires de striatum; la capture de DA est déterminée sur des cellules mésencéphaliques et celle du GABA sur les deux types cellulaires.

Tous les résultats sont exprimés en pourcentage de la valeur témoin.

RESULTATS

Le pourcentage de cellules vivantes décroît significativement après une exposition de 0,5 Gy et au-delà (figure 1).

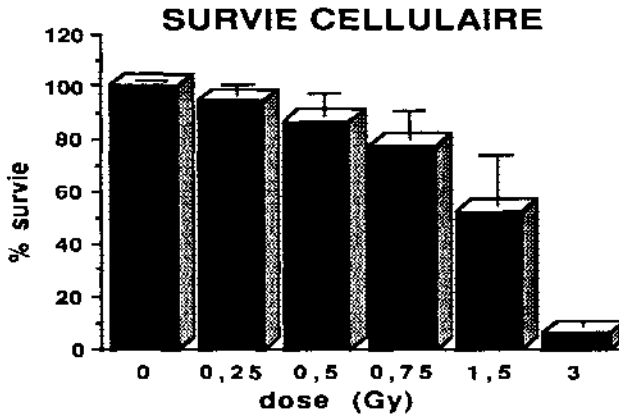

Le plus long prolongement des cellules nerveuses est réduit dès la dose de 0,25 Gy (figure 2).

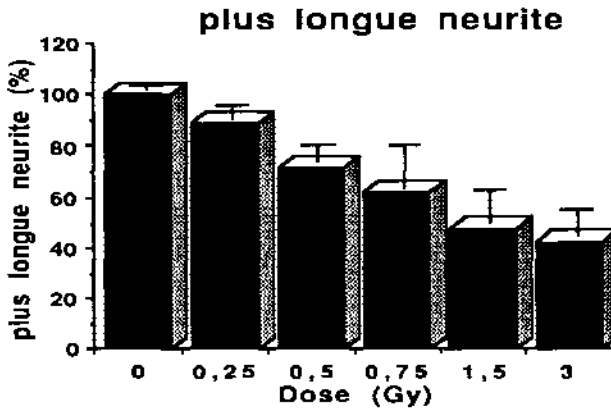

La capture de dopamine par les cellules mésencéphaliques et la capture de GABA par les cellules des 2 structures décroissent significativement avec 0,25 Gy et plus (figure 3 et 3').

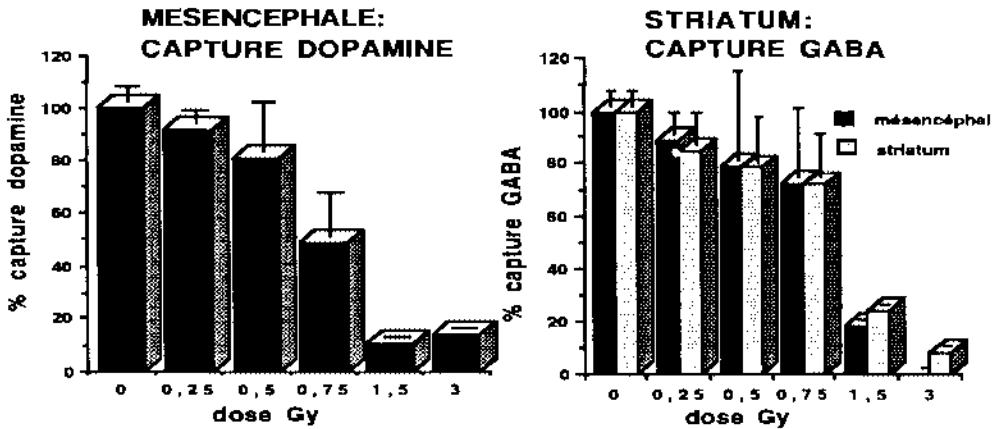

Pour tous les paramètres, l'effet est dépendant de la dose.

DISCUSSION

Chez les fœtus de souris, dès 0,1 Gy des perturbations de la migration neuronale (Kamayema, 1986) et des modifications de l'alignement des dendrites dans le cortex (Koner mann, 1986) sont observés chez l'animal devenu adulte. Cependant, ces effets ne sont bien établis qu'avec 0,2 Gy. Nos résultats semblent donc confirmer qu'il y a un seuil aux environs de 0,2 Gy pour provoquer un effet mesurable après irradiation.

Dans l'étude de la survie cellulaire, les cellules striatales sont un peu plus radio-résistantes que les cellules mésencéphaliques. Par contre, lorsque la capture de GABA est le paramètre étudié, les cellules des deux structures ont la même radiosensibilité.

Cette étude associant le test classique de la survie cellulaire à des phénomènes de croissance et de fonction des cellules nerveuses permet d'apprécier la radiosensibilité cellulaire sur différents aspects. Ce type de travail est également développé par l'équipe suédoise de Walinder (Int. J. Radiat. Biol. sous presse) avec des cellules nerveuses cultivées sous forme de sphéroïdes. Cependant, aucun travail sur les effets de l'irradiation sur des cellules nerveuses en culture n'a encore été publié.

Conclusion

La mise au point de ce modèle d'étude in vitro des cellules nerveuses a permis de déterminer un seuil d'effet de l'irradiation gamma à moins de 0,25 Gy. Ce seuil est déterminé à l'aide de paramètres morphologiques et fonctionnels complétant ainsi les études histologiques classiques des autres auteurs. Pour des doses d'irradiation plus fortes l'effet sur ces paramètres est dépendant de la dose reçue.

Cette étude se prolongera par la mesure de la survie

cellulaire et de la croissance des neurites des cellules dopaminergiques et gabaergiques identifiées par immunohistochimie. Ceci permettra de définir si ces deux populations cellulaires sont plus ou moins sensibles à l'irradiation que l'ensemble des cellules nerveuses et donc de savoir si la réduction de la capture est liée à une réduction du nombre des cellules spécifiques ou à une modification de l'affinité des récepteurs et/ou de leur nombre.

REFERENCES

- 1- Coffigny H., Beauvallet M. and Court L. 1990, Irradiation effects on mesencephalic and striatal nerve cells in culture. 23rd Annual Meeting of the European Society for Radiation Biology. Dublin, Ireland, september 24-26.
- 2- Kameyama y. and Hoshino K. 1986, Sensitive Phases of CNS Development. p.75-92 In "Radiation Risks to the Developing Nervous System", (H. Kriegel et al., eds.). Gustav Fischer Verlag, Stuttgart, New York.
- 3- Konermann G. 1986, Brain Development in Mice After Prenatal Irradiation: Modes of Effect Manifestation; Dose-Response-Relationships and the RBE of Neutrons. p.93-116 In "Radiation Risks to the Developing Nervous System", (H. Kriegel et al., eds.). Gustav Fischer Verlag, Stuttgart, New York.
- 4- Otake M. and Schull W. 1984, *In utero* exposure to A-bomb radiation and mental retardation: a reassessment. Br. J. Radiol., 57, 409-414.

ETUDE DE LA TOXICOCINETIQUE DU TECHNETIUM 95M CHEZ LE RAT
NOUVEAU-NÉ, ADULTE PENDANT LA GESTATION ET LA LACTATION.

ARCHIMBAUD Yves (1), PONCY Jean-Luc(1), COGNEAU Michel (2),
MASSE Roland (1).

(1)C.F.A./DSV/DPTE/Laboratoire de Radiotoxicologie 91680 Bruyères le Châtel
France (2)Laboratoire de chimie inorganique et nucléaire B1348 Louvain la
Neuve Belgique

TOXICOKINETIC OF 95M TECHNETIUM FOR NEWBORN AND PREGNANT RATS

ABSTRACT

In the future, technetium, a part of nuclear wastes, may increase dose equivalent delivered to members of the public. Technetium toxicokinetic was studied on newborn and pregnant rats. Results indicated concentration of technetium in the skin (95%), the kidney (3,5%) and the thyroid (1%).

INTRODUCTION

Le technétium 99 (^{99}Tc), émetteur bêta, est un produit de fission de l'uranium 235, de l'uranium 238 et du plutonium 239 présent dans les déchets nucléaires. En cas de dispersion dans l'environnement, le pertechnétate de Tc (forme probable de retour à l'homme), pourrait contribuer à l'augmentation des équivalents de dose potentiellement délivrés aux générations futures(2)(7), en raison de sa longue période radioactive (213000 ans). Rappelons que la CIPR fixe une limite annuelle d'incorporation par ingestion à 10^8 Bq pour le Tc, en retenant un coefficient d'absorption intestinal (f1) de 0,8, les organes de rétention étant la thyroïde, le foie et le tractus gastro-intestinal(5). Les références utilisées pour l'élaboration des recommandations de la CIPR(1)(9) laissent apparaître un manque de données expérimentales sur le comportement du Tc dans les divers états physiologiques. Le but de ces expérimentations réalisées à l'aide de ^{95m}Tc , émetteur gamma de période radioactive égale à 61 jours a été de préciser la toxicocinétique de l'élément après ingestion chez le rat nouveau-né, adulte et chez la ratte pendant la gestation et la lactation.

MATERIELS ET METHODES

L'étude toxicocinétique a été réalisée sur des rats Sprague Dawley (OFA, IFFA - CREDO). Une solution saline de pertechnétate de technétium, obtenue au cyclotron de Louvain la Neuve par irradiation de molybdène naturel par des protons de 50 Mev, a été administrée par sonde intragastrique à 8 rats nouveaux-nés (âgés de 6 heures lot1), à 12 mâles (âgés de 3 mois lot2) et à

8 femelles au 2ème jour de gestation (lot3). L'activité des animaux a été déterminée périodiquement par spectrométrie gamma pendant toute la durée des expérimentations (2 mois lot1; 14 jours lot2; 2 mois lot3). Les rats ont été sacrifiés 1, 2 mois (lot1), 1,3,7,14 jours (lot2) et à la fin de la période de lactation (2mois-lot3). Les animaux du lot 2 ont été placés dans des cages à métabolisme. Les reins, le foie, la thyroïde, le tractus gastro-intestinal (débarrassé de son contenu par lavage avec une solution de NaCl à 9%), le pancréas, le coeur, les poumons, le thymus, la rate, la parotide les testicules et les ovaires ont été prélevés et pesés. Des échantillons de peau, de muscle, d'os et de sang ont été effectués. L'activité des échantillons a été déterminée par une sonde à scintillation constituée d'un cristal à iodure de sodium 3"x3", placée au fond d'un puit. Les résultats sont exprimés en pourcentage de l'activité initiale.

RESULTATS

La valeur du coefficient d'absorption gastro-intestinal du Tc95m sous forme de pertechnétate chez le rat adulte après administration intragastrique, a été calculée d'après la formule suivante : (activité rétention + activité urinaire) / (activité totale). Le coefficient d'absorption apparent (le cycle entero-hépatique non pris en compte) est égal à 0,77 le 1er jour. (Tableau II)

La distribution et la rétention du Tc en fonction du temps chez les rats nouveaux-nés et les femelles gestantes sont présentées dans le tableau I. Les activités du sang, de la rate, du coeur, des poumons, des surrénales et de la parotide sont inférieures au seuil de détection. Les organes de rétention au 60ème jour sont selon un ordre décroissant : la peau, les reins, la thyroïde. La rétention globale du Tc suit une loi bi-exponentielle (figure 1). Les activités dans l'urine et dans les fèces chez les adultes sont inférieures à 1% de l'activité initiale 3 jours après administration du Tc. Le rapport entre l'excrétion urinaire et fécale est égale 0.85 après administration intragastrique. (tableau II)

DISCUSSION

La valeur du coefficient d'absorption apparent observés chez les rats adultes valide le choix de 0,8 par la CIPR pour le f1. La rétention globale du Tc chez les nouveaux-nés est inférieure d'un facteur 4 à celle des rattes au 60ème jour : la demi-vie du compartiment long terme est plus courte chez les nouveaux-nés que chez les femelles gestantes. La distribution du ^{95m}Tc est identique chez les nouveaux-nés et les femelles gestantes. L'organe de rétention prédominant est la peau (95% de l'activité totale) dont l'activité élevée peut s'expliquer par une contamination externe par léchage; cependant cette activité persiste dans le temps et s'avère élevée dans la région lombaire, dans une zone où la contamination externe est improbable. Rappelons que Sullivan et al.(9) observent une affinité du Tc pour des protéines du tissu cutané.

TABLEAU I : Distribution du ^{95m}Tc en % de l'activité initiale chez le rat nouveau-né et la femelle gestante suite à une instillation intragastrique.

Jour	NOUVEAU-NE	NOUVEAU-NE	FEMELLE GESTANTE
	30	60	60
Rein	0,416±0,054	0,038±0,008	0,169±0,035
Foie	0,040±0,009	ND	ND
TGI	0,054±0,021	ND	ND
Thyroïde	0,016±0,005	0,003±0,001	0,059±0,016
Peau	8,470±0,650	1,050±0,240	4,553±1,139
Animal	8,995±0,739	1,091±0,249	4,781±1,190

(moyenne ± écart-type de 4 animaux) ND = Non détectable

TABLEAU II Excrétions urinaire et fécale et rétention du ^{95m}Tc chez le rat suite à une instillation intragastrique.

Période de recueil (jours)	% Tc ^{95m} injecté (moyenne ± écart-type)			JOUR	RETENTION
	URINE	FECES			
0-1	31,3 ± 7,4	23,0 ± 7,5		1	45,70 ± 6,12
1-2	4,9 ± 0,3	17,1 ± 1,3			
2-3	1,6 ± 0,2	4,0 ± 0,3		3	18,05 ± 3,58
3-7	0,9 ± 0,2	0,9 ± 0,2		7	16,28 ± 3,44
7-14	0,4 ± 0,1	0,4 ± 0,1		14	15,52 ± 3,01
Total 0-14	39,2 ± 7,7	45,4 ± 5,9			

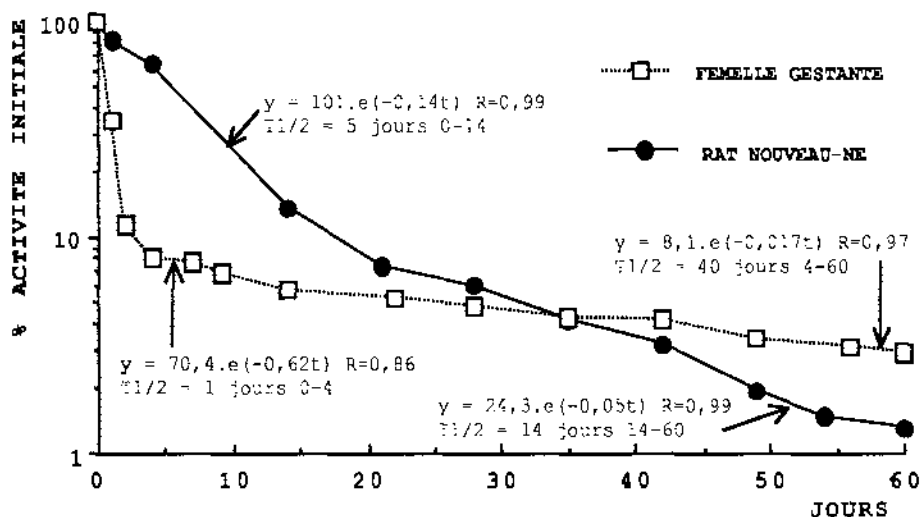

Figure 1: Rétention du Technétium ^{95m} chez le rat

Les autres organes de rétention sont les reins et la thyroïde. Les résultats pour les organes de rétention concordent avec les données de la littérature(3)(4)(6)(8). Rappelons cependant que l'ICRP ne mentionne pas la peau (5).

CONCLUSION

L'étude de toxicocinétique du ^{95m}Tc sous forme de pertechnétate chez le rat à différents stades physiologiques met en évidence une rétention de Tc variable suivant l'âge, toujours élevée au niveau de la peau, du rein et de la thyroïde ainsi qu'une excrétion rapide et intense. Ces données permettent de recalculer la dose efficace délivrée aux nouveaux-nés. L'évaluation de la dose engagée dans la peau devrait être prise en compte sur le plan sanitaire. Dans cette perspective, des études complémentaires sont à envisager pour localiser les sites de rétention cellulaire et intracellulaire du Tc dans le tissu cutané.

BIBLIOGRAPHIE

- 1 BEASLEY T.M., PALMER E.F., NELPS W.B. Distribution and excretion of technetium in humans. Health Phys. 1966, 12, 1425-1435.
- 2 Di GREGORIO D., KITCHING T., VAN VORIS P. Radionuclide transfer in terrestrial animals. Health Phys. 1978, 34, 3-11.
- 3 GARTEN C.T., MYTTENAERE C., VANDECASTEELE C.M., KIRCHMANN R., VAN BRUWAENE R. Chemical form of technetium in corn and the gastro-intestinal absorption of plant-incorporated Tc by laboratory rats. In Technetium in the environment. (Desmet, G; Myttenaere, C; Ed.). London. New York : Elsevier Appl. Science Publ., 1986, 319-332.
- 4 GERBER G.B., VAN HEES M., GARTEN C.T., VANDECASTEELE C.M., VANKERKOM J., VAN BRUWAENE R., KIRCHMANN R., COLARD J., COGNEAU M. Technetium absorption and turnover in monogastric and polygastric animals. Health Phys. 1989, 57, 315-319.
- 5 ICRP Statement and recommendations of the 1980 Brighton Meeting of the ICRP (ICRP Publication 30, part 2,). Oxford: Pergamon Press, 1980.
- 6 JONES B.E. Technetium metabolism in goats and swine. Health Phys. 1989, 57, 331-336.
- 7 QUINAULT J., GRAUBY A. Estimations des risques radiologiques liés à un rejet concerté de technétium dans l'environnement. In: Technetium in the environment. (Desmet, G; Myttenaere, C; Ed.). London. New York : Elsevier Appl. Science Publ., 1986, 377-382.
- 8 SULLIVAN M.F., MILLER B.M., GOBEL J.C. Gastro-intestinal absorption of metals (^{51}Cr , ^{65}Zn , ^{95m}Tc , ^{109}Cd , ^{113}Sn , ^{147}Pm , and ^{238}Pu) by rats and swine. Env. Research. 1984, 35, 439-453.
- 9 SULLIVAN M.F., GRAHAM T.M., CATALDO D.A., SCHRECKHISE R.G. Absorption and retention of inorganic and originally incorporated technetium-95 by rats and guinea pigs. In : Pacific Northwest Laboratory Annual Report for 1977, Part1 Biomedical Sciences, Feb. 1978, PNL-2500PT1.

INFLUENCE DU DEBIT DE DOSE ET DE L'AGE A L'IRRADIATION SUR LES EFFETS
CANCEROGENES DU RAYONNEMENT GAMMA CHEZ LE RAT SPRAGUE-DAWLEY.

M. Morin

CEA-CENFAR, DSV-DPTE-STCE
BP n°6, 92265, Fontenay aux Roses Cedex.

EFFECT OF DOSE-RATE AND AGE AT IRRADIATION ON CANCER DEVELOPMENT
IN SPRAGUE-DAWLEY RATS EXPOSED TO GAMMA RAYS.

The probability that rats develop tumors following a 3 Gy exposure to gamma rays from cobalt 60 was observed to depend on age at exposure and on dose rate. Dose rate reduction by a factor of 60 decreased the carcinogenic incidence (mainly carcinomas) by a factor of about 5. Lifetime excess of malignant neoplasia decreased by a factor of about 10 in 9 month-old rats as compared to animals irradiated in utero. The 3 month age group developed slightly fewer cancers than the group irradiated in utero, and tumor location was different. The higher incidence of tumors following in utero exposure was dependent to the high sensitivity of brain and gonads during organogenesis.

INTRODUCTION

L'étude de groupes humains exposés à diverses sources de rayonnement ionisant, accidentelles ou thérapeutiques, a permis d'évaluer un risque d'excès de cancers en relation avec le niveau d'exposition. Les enquêtes épidémiologiques n'ont pas mis en évidence une augmentation du taux de cancers dans les groupes exposés à de faibles doses d'irradiation délivrées de façon chronique à faible débit de dose. L'évaluation du risque pour les faibles débits de dose, résultant d'extrapolations provenant d'observations faites à fortes doses et forts débits, reste incertaine. L'expérimentation animale apparaît indispensable pour vérifier si la diminution du débit de dose entraîne une diminution du risque cancérigène. Les expositions pouvant porter sur des périodes très longues représentant une fraction importante de la durée de vie, il est nécessaire de prendre en compte dans l'estimation du risque l'influence du vieillissement, et donc de l'âge au moment de l'irradiation.

METHODE

Les animaux utilisés sont des rats de souche Sprague-Dawley SPF qui ont été irradiés globalement par le rayonnement gamma d'une source de cobalt 60 à une dose cumulée totale de 2.5 à 3 Gy. Cette dose a été délivrée sur une durée variant de 38 heures à 14 semaines. Les animaux ont été irradiés à des âges différents, depuis le stade fœtal jusqu'à l'âge de 9 mois.

- Une première série, de mâles et femelles, a été irradiée du huitième jour après l'accouplement jusqu'au jour de la naissance (2.66 Gy - 53 mGy/h).

- Une deuxième série, de mâles, a été irradiée à l'âge de 3 mois (3 Gy - 78 cGy/h délivrés en 38 heures).

- Une troisième série, de mâles et femelles, a été irradiée à l'âge de 9 mois (3 Gy - 39 cGy/h pendant 5 jours).

- Enfin, pour étudier le rôle du débit, une quatrième série, de mâles, a été irradiée à l'âge de 3 mois à faible débit de dose (2.83 Gy - 1.34 mGy/h pendant 14 semaines).

Ces animaux ont été comparés à des animaux témoins mâles et femelles.

Les rats ont été surveillés quotidiennement jusqu'à leur mort, et les prélèvements effectués ont été fixés dans du Bouin-Hollande. A l'autopsie, toutes les lésions et tumeurs ont été prélevées ainsi qu'un certain nombre d'organes (poumons, cerveau, rein, foie, rate, thyroïde, hypophyse). L'examen anatomopathologique a été effectué sur des coupes de 5 microns après coloration à l'hémalum-éosine-safran.

RESULTATS

- Effets sur la durée de vie (tableau 1):

	sexe	nombre	dose (Gy)	débit (mGy/h)	âge (jours) début irradiation	durée de vie (jours)
témoins	M	785				833 ± 126
	F	120				750 ± 130
série 1	M	66	2.66	53	- 15	737 ± 151
	F	65	2.66	53	- 15	765 ± 131
série 2	M	120	3	78	90	738 ± 160
série 3	M	120	3	39	280	755 ± 138
	F	60	3	39	280	698 ± 126
série 4	M	304	2.83	1.34	90	726 ± 160

La durée de vie des rats a été diminuée par l'irradiation, mais ni l'âge au début de l'exposition ni le débit de dose n'ont eu d'influence sur la longévité des animaux.

- Effets sur l'incidence tumorale (Fig. 1 et 2) et tableau 2:

	Cancers en excès par rapport aux témoins (%)					
	Fœtus		3 mois	3 mois faible débit	9 mois	
	M	F	M	M	M	F
Total	46.6	82.2	43.7	20.6	5.2	- 1.4
Carcinomes sans THS*	18.8	60.3	18.9	3.3	3.9	- 1.6
Sarcomes sans cerveau	7.4	0.5	14.9	15.4	8.9	6.0
THS*	8.4	9.1	9.9	- 3.3	- 7.7	+ 5.8
Cerveau	12.0	12.3	-	5.2	0.1	0

*THS : Thyroïde, Hypophyse, Surrénales

1) Les carcinomes

Les tumeurs de la thyroïde, de l'hypophyse et des surrénales, organes endocrines dont l'évolution dépend plus du mode de vie que de l'exposition aux rayonnements et pour lesquels aucune relation dose-effet n'est

évidente, ont été considérées séparément. On a observé de la même façon dans la population humaine que le taux de cancers de la thyroïde était une variable non contrôlable.

La diminution du débit de dose a réduit l'incidence des carcinomes, et en particulier des poumons (d'un facteur 3), de la peau et des reins (d'un facteur 8).

C'est chez les rats irradiés à l'âge le plus avancé que l'excès de carcinomes par rapport aux témoins s'est avéré le plus faible.

Un excès significatif de cancers des organes reproducteurs a été observé chez les rats irradiés à l'état fœtal, en particulier chez les femelles dont les ovaires ont été particulièrement radiosensibles pendant l'organogenèse. L'excès de cancers des organes reproducteurs était de: 51.2% pour les femelles et de 5.6% pour les mâles dans la série des fœtus irradiés; aucun excès de cancers des gonades n'a été vu chez les animaux irradiés à 3 mois ou à 9 mois.

2) Les sarcomes

Le cerveau s'est révélé être très radiosensible pendant la période fœtale, alors qu'aucun excès de tumeurs cérébrales n'était observé chez les animaux irradiés à 9 mois. Le cerveau ayant été analysé de façon non systématique dans une des séries (3 Gy - 78 mGy/h), nous avons exclu la donnée pour cette série.

Les sarcomes, autres que cérébraux, ont été peu sensibles à l'influence de l'âge et du débit de dose.

DISCUSSION

- Rôle relatif de l'âge et du débit de dose.

L'action de ces deux facteurs est différente selon que l'on considère les carcinomes ou les sarcomes. L'augmentation de l'âge et la diminution du débit de dose ont agi, dans le même sens, en diminuant l'incidence des carcinomes, l'influence du débit semblant prépondérante.

En ce qui concerne les sarcomes, les variations de débit ont peu modifié l'incidence des tumeurs alors que l'augmentation de l'âge diminuait l'induction tumorale.

Une diminution du débit de dose d'un facteur 60 a réduit l'excès de carcinomes d'un facteur supérieur à 5.

Pour une même dose absorbée et un débit de dose équivalent, l'excès de cancers chez les mâles a été diminué d'un facteur 9 chez les rats irradiés à 9 mois par rapport aux rats irradiés en période fœtale; chez les femelles, le facteur de diminution entre ces deux séries apparaissait plus important en raison de l'incidence de cancers ovariens, élevée chez les fœtus et nulle chez les rates de 9 mois.

Dans la série irradiée à l'état fœtal, l'excès de cancers est dû essentiellement à la grande radiosensibilité du système nerveux central et des organes reproducteurs au moment de leur organogenèse.

CONCLUSION

Ces expériences ont montré que l'âge et le débit de dose avaient, selon les tissus et les types histologiques concernés, une influence complexe sur la cancérogenèse après irradiation. Le choix d'utiliser un seul facteur d'atténuation, pour passer des résultats des expositions à fort débit de dose à l'estimation du risque des expositions chroniques à faible dose et faible débit, ne peut conduire qu'à des approximations dont la justification est discutable.

Fig.1-Cancers en excès chez le rat après irradiation gamma.
Action du débit de dose et de l'âge à l'irradiation.

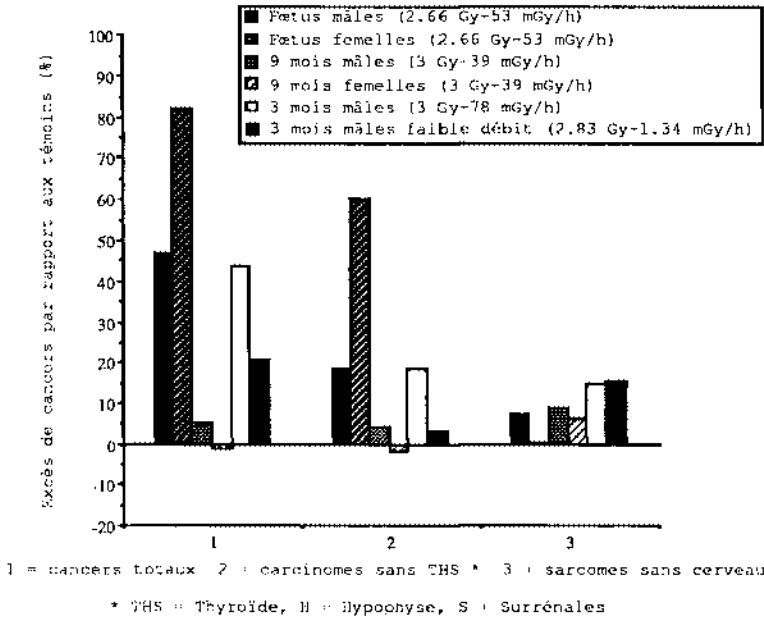
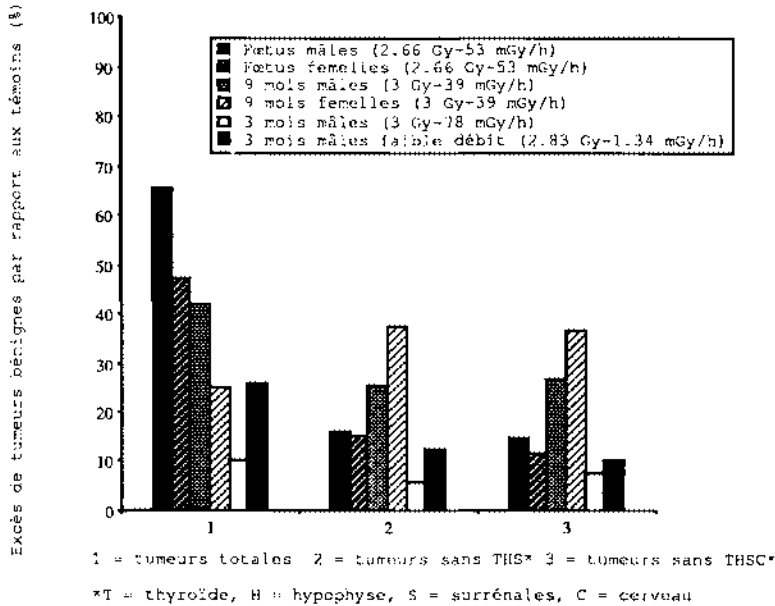

Fig. 2 - Tumeurs bénignes en excès après irradiation gamma.
Action du débit de dose et de l'âge à l'irradiation.



COMPARISON OF THE EFFECTS OF INHALED $^{239}\text{PuO}_2$ AND β -EMITTING
RADIONUCLIDES ON THE INCIDENCE OF LUNG CARCINOMAS IN
LABORATORY ANIMALS

F.F. Hahn, W.C. Griffith, B.B. Boecker,
B.A. Muggenburg and D.L. Lundgren

Inhalation Toxicology Research Institute
P.O. Box 5890
Albuquerque, New Mexico 87185, U.S.A.

ABSTRACT: The health effects of inhaling radioactive particles when the lung is the primary organ irradiated were studied in rats and dogs. The animals were exposed to aerosols of $^{239}\text{PuO}_2$ or fission-product radionuclides in insoluble forms and observed for their life span. Lung carcinomas were the primary late-occurring effect. The incidence rate for lung carcinomas was modeled using a proportional hazard rate model. Linear functions predominated below 5 Gy to the lung. The life-time risk for lung carcinomas per 10^4 Gy for beta emitters was 60 for rats and 65 for dogs, and for $^{239}\text{PuO}_2$ it was 1500 for rats and 2300 for dogs.

INTRODUCTION: Irradiation of the lung in sufficiently high doses is known to result in lung carcinomas. This result has been demonstrated in populations of patients with ankylosing spondylosis treated with thoracic irradiation, in survivors of atomic bomb explosions in Japan, and underground miners exposed to radon and radon daughter products. None of these situations, however, directly applies to chronic alpha or beta irradiation of the deep, or alveolar, portions of the lung. Such can occur if individuals inhale radioactive particles such as might be released in reactor accidents or waste transportation accidents. No human populations are available for study that have inhaled particles of alpha- or beta-emitting radionuclides which deposit deep in the lung. To address this situation, studies were initiated at the Inhalation Toxicology Research Institute to establish the dose-response relationships resulting from the inhalation of plutonium dioxide or beta-emitting radionuclides with different radioactive half-lives. This paper briefly summarizes the dose-response for lung carcinomas induced by these types of lung irradiation.

METHODS: Details of the experimental design, animal exposure, dosimetry, and husbandry techniques have been reported.¹⁻³ Beagle dogs were exposed briefly, per nasum, to aerosols of $^{239}\text{PuO}_2$ of different monodisperse particle size or ^{90}Y , ^{91}Y , ^{144}Ce or ^{90}Sr in relatively insoluble forms. F344 rats were similarly exposed but only to $^{239}\text{PuO}_2$ or $^{144}\text{CeO}_2$. The animals were observed for their life spans for resulting biologic effects. At present, all animals have died, except for some of the dogs exposed to $^{239}\text{PuO}_2$. The incidence rate for lung carcinomas was modeled as the observed time course for the appearance of carcinomas using a proportional hazard rate model. The proportional hazards calculation of relative and absolute risks was made using the following relationships:

$$\text{Proportional hazards: } \lambda(t) = \lambda_0(t)(1 + \beta D(t)).$$

In this relationship, $\lambda(t)$ is the age-specific lung tumor incidence rate at dose $D(t)$, $\lambda_0(t)$ is the background lung tumor incidence rate, β is the relative risk coefficient, and $D(t)$ is the

time-dependent, cumulative absorbed dose to the lung. The relative and lifetime absolute risks are:

$$\text{Relative risk per Gy} = \beta$$

$$\text{Lifetime risk per Gy} = \frac{1}{D(t)} \int_0^t S(\tau) (\lambda(\tau) - \lambda_0(\tau)) d\tau,$$

where $S(\tau)$ is the fractional survival at time τ . This method is similar to the techniques used in the BEIR IV and BEIR V models of risk analysis.

RESULTS: The biological effects of these exposures have been documented elsewhere.³⁻⁶ Briefly, at the highest doses, animals died within months to 3 years with pulmonary injury. Those living longer (rats > 1 yr, dogs > 2 yr) developed a high incidence of lung tumors. Table 1 gives the total number of lung tumors seen, the relative distribution of tumor types for each species and the types of radiation.

TABLE 1

Distribution (%) of Lung Tumor Types in Animals that Inhaled Radionuclides and Were Observed for Life Span

LUNG TUMOR TYPE	RATS		DOGS	
	α -emitters	β -emitters	α -emitters	β -emitters
(# of Tumors)	(172)	(24)	(108)	(110)
Adenoma	9	13	1	2
Adenocarcinoma	70	62	96	59
Squamous Cell Carcinoma	19	21	1	9
Hemangiosarcoma	1	4	0	25
Other Sarcomas	1	0	2	5

The predominant tumor types were adenocarcinomas and squamous cell carcinomas for rats and for dogs, adenocarcinomas and hemangiosarcomas. The hemangiosarcomas and other sarcomas are unusual tumors and occurred at higher doses. The dose-response analyses are based on the carcinoma incidences.

For dogs, the relative risk was estimated by summing a linear function of dose and a power function of dose. The power function applies to the higher doses and the linear function of dose predominates over the power function at doses below 5 Gy for beta irradiation and 0.5 Gy for alpha irradiation (Fig. 1).

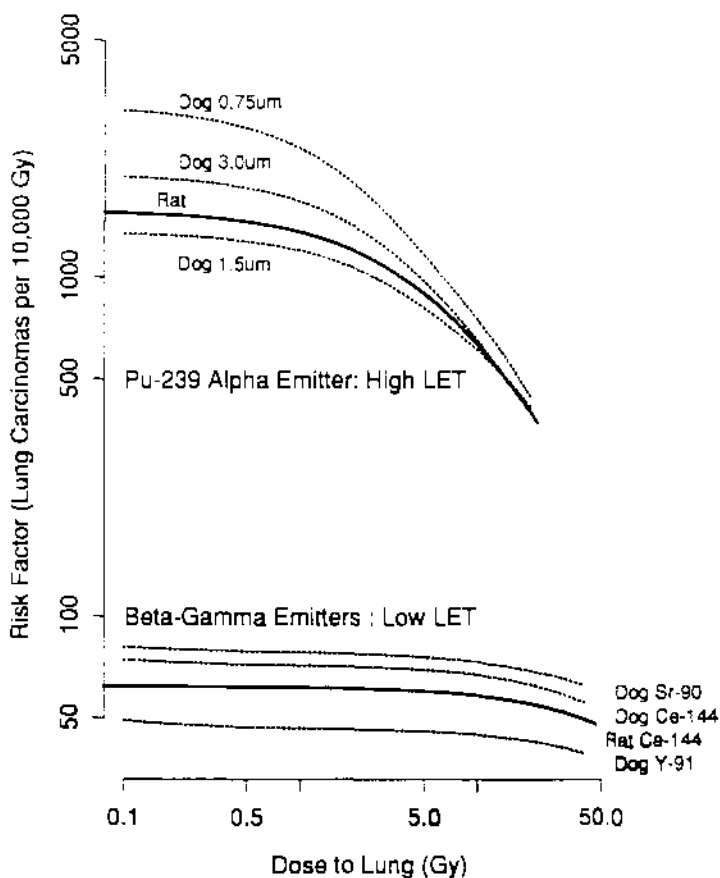

FIGURE 1 - Risk factors for lung carcinomas in dogs and rats that inhaled $^{239}\text{PuO}_2$ or beta-emitting radionuclides.

These analysis show a reasonable agreement between the life-time risks for lung carcinomas for rats and dogs for both alpha- and beta-emitting radionuclides.

Lifetime risks of lung carcinomas were calculated by integrating, over the life-time, the sum of the estimated lung carcinoma incidence rate at 1 Gy from the proportional hazard rate model and the mortality rate for competing causes of death in the control animals. The dose of 1 Gy was used because it did not cause an increase in competing causes of death. The lifetime risks of lung carcinomas per 10^4 Gy for beta-emitting radionuclides were 60 for rats and 65 for dogs. For $^{239}\text{PuO}_2$ the lifetime risk was 1520 for rats and 2300 for dogs. The ratio of $^{239}\text{PuO}_2$ risk to beta-emitter risk is 25 for rats and 36 for dogs. Although those ratios are higher than the presently accepted quality factor of 20 for alpha and x-irradiation, the uncertainties in this analysis would not exclude a value of 20. On the other hand, the results may indicate that the quality factor of 20 is too low for comparing radiation-induced lung carcinoma incidence of alpha irradiation with that of beta irradiation.

ACKNOWLEDGEMENTS: Research supported by the U.S. DOE/OHER under Contract No. DE-AC04-76EV01013 in facilities fully accredited by the American Association for the Accreditation of Laboratory Animal Care.

REFERENCES

1. McClellan, R.O., Boecker, B.B., Hahn, F.F. and Muggenburg, B.A., 1986. Lovelace ITRI Studies on the Toxicity of Inhaled Radionuclides in Beagle Dogs, pp. 74-96 in *Life-Span Radiation Effects in Animals: What can they tell us?* Eds. Thompson, R.C. and Mahaffey, J.A., Office of Scientific and Technical Information, U.S.,D.O.E., CONF - 830951
2. Lundgren, D.L., Hahn, F.F., Diel, J.H. and Snipes, M.B., 1991. Repeated Inhalation Exposure of Rats to Aerosols of $^{144}\text{CeO}_2$ I. Dosimetry. *Radiation Research* (Submitted).
3. Lundgren, D.L., Haley, P.J., Hahn, F.F., Diel, J.H., Griffith, W.C. and Scott, B.R., 1991. Pulmonary Carcinogenicity of Repeated Inhalation Exposure of Rats to Aerosols of $^{239}\text{PuO}_2$. *Radiation Research* (Submitted).
4. Lundgren, D.L., Hahn, F.F., Diel, J.H., 1991. Repeated Inhalation Exposure of Rats to Aerosols of $^{144}\text{CeO}_2$ II Biological Effects. *Radiation Research* (Submitted).
5. Hahn, F.F. and Lundgren, D.L., 1991. Morphologic Characteristics of Lung Tumors in Rats That Inhaled $^{144}\text{CeO}_2$. *Toxicologic Pathology* (Submitted).
6. *Annual Report on Long-Term Dose-Response Studies of Inhaled or Injected Radionuclides, Oct. 1, 1989 through Sept. 30, 1990* (1991). Eds. Boecker, B.B., Muggenburg, B.A., Miller, S.C. and Bradley, P.L., National Technical Information Service, U.S. DOE, LMF-130.

IMPROVEMENTS IN LUNG LAVAGE TO INCREASE ITS EFFECTIVENESS IN REMOVING INHALED RADIONUCLIDES

B.A. Muggenburg, R.A. Guilmette, L.M. Romero,
and J.A. Mewhinney

Inhalation Toxicology Research Institute
Albuquerque, New Mexico, USA

ABSTRACT: Lung lavage has been shown to be an effective method to remove insoluble radionuclides deposited and retained in the lung, but the treatment has been limited to the effective removal of only about 50% of the retained material. Reported here is a change in lavage technique that slightly increases the effectiveness and the addition of high-frequency chest wall oscillation. The latter increased the effectiveness of the lavage procedure but also caused significant physiological complications.

INTRODUCTION: Radioactive particles in relatively insoluble forms inhaled and deposited in the lung will be retained for long periods of time¹. For radionuclides with long physical half-lives, such as plutonium, this will result in the chronic irradiation of the lung (and lung associated lymph nodes) and the potential development of health effects. Decorporation of insoluble particles from the lung is limited at this time to lung lavage². Lung lavage has been shown to be effective in removing a variety of radioactive particles, but its efficiency, even with multiple procedures is approximately 50%². Improvements in the lung lavage procedure are needed to increase its efficacy. This study evaluated two changes in the procedure, the use of a single lumen endotracheal tube³ in place of the double lumen tube previously reported⁴, and the use of high-frequency chest wall oscillation (HFCWO). Both of these techniques improved the efficacy of the lavage treatment, but the use of the HFCWO induced some serious physiological complications.

METHODS: These studies were conducted in adult male and female beagles. The aerosol in the first study was ²³⁹PuO₂ heat-treated at 850° C, obtained as a powder from a commercial V-blending process. The dogs briefly inhaled the aerosol per nasi. The tissue content at death and the amount of ²³⁹Pu excreted and in the recovered lung lavage fluid was determined by radiochemical methods⁵. These values were used to reconstruct the initial pulmonary burden of ²³⁹Pu and the amount of ²³⁹Pu removed by lavage. In the second study, with the HFCWO, the aerosol was ⁸⁵Sr fused in aluminosilicate particles. The IPB of ⁸⁵Sr was determined by whole-body counting. The excreta and recovered lung lavage fluids were also assayed for ⁸⁵Sr activity.

In both studies, the lung lavage procedure employed the use of a single-lumen endotracheal tube as previously described³. Briefly, the dogs were anesthetized with halothane, an endotracheal tube placed in the trachea, and a T-tube connected to the end of the endotracheal tube. One end of the T-tube was connected to the anesthetic circuit to maintain anesthesia and for manual ventilation of the dog. The other end of the T-tube was connected by latex tubing to the lavage apparatus, which was simply a container of normal saline at room temperature suspended approximately 60 to 80 cm above the dog. A second T-tube was used in the lavage tubing to extend a latex tube to the floor to drain the recovered lavage fluid into a vessel. Clamps on the tubing were used to direct the flow of fluid or to permit

only the anesthetic/oxygen gas to reach the dog. Once the lavage apparatus was connected, the dog was manually ventilated for approximately 3 minutes to induce apnea, then placed on the table with the side to be lavaged in the down position, and a volume of saline equal to 40% of the estimated residual functional capacity was instilled in the lung. This fluid was then drained out of the lung into the vessel on the floor. Apnea, induced by several minutes of manual ventilation was repeated and then another wash was done. This procedure was repeated until 4 to 5 L of saline was used.

In the first experiment with $^{239}\text{PuO}_2$, the dogs were lavaged, alternating the right and left lung in each procedure on days 2 (both lungs were done), 7, 10, 14, 21, 28,35, 42, and 49 after inhalation exposure. There were two groups of dogs, a control group (2 dogs) and a lung lavage treated group (3 dogs). The dogs were euthanized 64 days after exposure by the intravenous injection of sodium pentobarbital to deep surgical anesthesia followed by exsanguination.

In the second experiment, a single lavage procedure was done on day 7 in which both lungs were lavaged. There were 4 groups of 2 dogs each in this study; 1) controls, 2) lung lavage only, 3) HFCWO simultaneous with lavage, and 4) HFCWO before lavage. The device used to perform HFCWO has been described⁶. It was operated at 13 Hz with a symmetric sine-wave input. The transducer was coupled to the dependant chest wall such that the middle of the device was at the midpoint of the rib cage. Two regimens of HFCWO therapy were followed. For group 3, HFCWO was administered during the time the lavage fluid was present in the lung but not during drainage or instillation of the fluid. Treatment time was approximately 30 minutes. Group 4 was treated for a 30 minute period just before the lung lavage was done. The dogs were euthanized 10 days after inhalation exposure.

RESULTS AND DISCUSSION: The distribution of $^{239}\text{PuO}_2$ in the excreta, lavage fluid, and tissues of the dogs that inhaled plutonium in the first experiment are shown in Table 1. The untreated controls had 70% of the initial lung burden in the lung at 64 days after exposure compared to 13% in the treated dogs. In the control dogs, most of the other plutonium was excreted in the feces with only about 5% being in other tissues. In the treated dogs, 66% of the IPB was removed in the lavage fluid, and, like the controls, the remainder was in the feces with about 5% in other tissues.

Table 1
Plutonium Activity in Excreta, Lavage Fluid, and Tissues of Dogs 64 Days
after Inhalation of $^{239}\text{PuO}_2$ with or without Lung Lavage

Group	No. of Dogs	Percent Initial Pulmonary Burden					
		Feces	Urine	Lavage Fluid	Lung	Liver	Skeleton
Control	2	24	0.1	-	70	0.01	ND
Treated	3	15	0.3	66	13	0.04	0.4

ND=not detected

In a previous study in dogs (n = 12) that inhaled $^{239}\text{PuO}_2$ in which a double lumen endotracheal tube method of lavage was used, the amount of plutonium removed by lung

lavage was approximately 44% of the IPB, with about 30% of the IPB remaining in the lung, 22% in the feces, and about 4% in other tissues at 64 days after inhalation of the plutonium aerosols⁷. A comparison of these similar studies suggests that the single lumen endotracheal tube method for lung lavage may be more effective than the double lumen tube method in removing radioactive particles from the lung. A possible increase in efficacy of nearly 20% is a significant improvement in the method; however, we must interpret this information cautiously because of the few numbers of animals involved and because the studies were not designed for direct comparison.

In the second study in which HFCWO was used, 85% of the IPB was in the lung of the control dogs at 10 days after inhalation of ⁸⁵Sr in fused aluminosilicate particles (Table 2). For the dogs that were treated only by lung lavage, the lung burden was 51% of the IPB and 44% was removed in the lavage fluid. The amount removed by lavage from these 2 dogs was higher than would be expected with only a single lavage procedure. Based on the study cited above, in which dogs inhaled ²³⁹PuO₂ and were treated with lavage, about 32% of the IPB would be expected to be removed in the first lavage of both lungs⁷. The third group, which also received HFCWO during the lavage procedure, had 34% of the IPB in the lung and 61% of the ⁸⁵Sr was removed by lavage. The last group, in which HFCWO was given before the lavage procedure, had 62% of the IPB in the lung and 32% removed in the lavage fluid. These results suggest that HFCWO during lavage, that is while the fluid is in the lung, does improve the effectiveness of the procedure. HFCWO performed before fluid was in the lung did not change the amount of radioactivity removed and appeared to be ineffective.

Table 2
⁸⁵Sr Activity in Excreta, Lavage Fluid, and Tissues for Dogs 10 Days after Inhalation of ⁸⁵Sr in Fused Aluminosilicate Particles and Treated with Lung Lavage and High Frequency Chest Wall Oscillation (HFCWO)

Group	No. of Dogs	Percent Initial Pulmonary Burden					
		Feces	Urine	Lavage Fluid	Lung	Liver	Skeleton
Control	2	9.8	2.2	-	84	ND	1
Lavage only	2	2.6	0.5	44	51	ND	0.5
Lavage with HFCWO	2	2.4	0.8	61	34	ND	0.7
HFCWO before lavage	2	2.2	1.2	32	62	ND	0.5

ND=not detected

The results from the lavage with HFCWO would have been very encouraging except for the accompanying pathophysiological sequelae. One dog from the group treated with lavage and HFCWO and one dog from the group that was treated with HFCWO before lavage died within 48 hours of the procedure from acute traumatic pneumonitis and pulmonary edema. The other 4 dogs from the groups treated with HFCWO and lavage had lung lesions at sacrifice, 72 hours after treatment, of inflammatory cell infiltrate and thickened alveolar septae with fibrin strands. Few indications of pulmonary edema remained.

These pathological effects were not expected because previous studies in dogs that employed either of the techniques did not result in significant damage to the lung. It appears, however, that the combination of treatments occurring close together in time produces very significant lung injury and therefore cannot be recommended at this time.

In summary, the lung lavage procedure using a single lumen endotracheal tube appears to remove radioactive particles from the lung more effectively than does the technique using a double-lumen tube. The increase in effectiveness may be as much as 50%. The HFCWO during lavage did improve the removal of radioactive materials from the lung, but serious lung injury occurred. Lung injury was not expected because previous studies with both of these techniques separately in dogs did not result in significant lung injury. The results from the studies with lavage and HFCWO were encouraging, but it is obvious that considerable work is needed to determine if a useful method can be developed.

ACKNOWLEDGEMENTS: Research supported by the U.S. DOE/OHER under Contract No. DE-AC04-76EV01013 in facilities fully accredited by the American Association for the Accreditation of Laboratory Animal Care.

REFERENCES

1. Snipes, M.B., 1989, Species Comparison for Pulmonary Retention of Inhaled Particles, in *Concepts in Inhalation Toxicology*, R.O. McClellan and R.F. Henderson, eds., Hemisphere Publishing, NY, 193-227.
2. Muggenburg, B.A., Felicetti, S.A., and Silbaugh, S.A., 1977, Removal of Inhaled Radioactive Particles by Lung Lavage - A Review, *Health Phys.* 33:213-220.
3. Muggenburg, B.A., and Mauderly, J.L., 1975, Lung Lavage Using a Single-Lumen Endotracheal Tube, *J. Appl. Physiol.* 38:922-926.
4. Boecker, B.B., Muggenburg, B.A., McClellan, R.O., Clarkson, S.P., Mares, F.J., and Benjamin, S.A., 1974, Removal of ^{144}Ce in Fused Clay Particles from the Beagle Dog Lung by Bronchopulmonary Lavage, *Health Phys.* 26:505-517.
5. Keough, R.F., and Powers, G.J., 1970, Determination of Plutonium in Biological Materials by Extraction and Liquid Scintillation Counting, *Anal. Chem.* 42:419-421.
6. Guilmette, R.A., Romero, L.M., and Muggenburg, B.A., 1987, Effect of High-Frequency Chest Wall Oscillation on the Clearance of Particles from the Peripheral Airways of Dogs, in *Inhalation Toxicology Research Institute Annual Report 1986-1987*, LMF-120, J.D. Sun, and J.A. Mewhinney, eds., National Technical Information Service, Springfield, VA, 169-172.
7. Muggenburg, B.A., Mewhinney, J.A., Slauson, D.O., Miglio, J.J., Ruoff, L., Mersch, S., and McClellan, R.O., 1976, The Removal of Inhaled ^{239}Pu from Beagle Dogs by Bronchopulmonary Lavage and Chelation Therapy, *Health Phys.* 31:315-321.

F. MENETRIER¹, Y. VERNOIS¹, and L. COURT²

¹ Commissariat à l'Energie Atomique, DSV/DPTE, BP6, 92265 Fontenay aux roses cedex FRANCE; ² Centre de Recherches du Service de Santé des Armées, BP87, 38700 La Tronche FRANCE.

EFFECTS OF A WHOLE BODY GAMMA IRRADIATION ON GABA REPARTITION IN INFANT RATS CEREBELLUM AND HIPPOCAMPAL FORMATION.

Thirteen-day-old rats were exposed to a single dose of 4 or 0,5 Gy of gamma at a dose rate of 0,25 Gy/min and were killed about 5h after. Fixation was achieved in situ using glutaraldehyde. For GABA immunocytochemistry transversal sections were incubated with antiserum against GABA, then with PAP and revealed with diaminobenzidine.

Proliferative layers are still observed in the infant rat cerebellum (external granular layer) and hippocampal formation (subgranular layer of the dentate gyrus). When irradiation occurs a high percent of these two layers cells are pycnotic.

In the normal cerebellum, no immunostaining is observed in external granular layer cell bodies. The only labelled structures are few cytoplasmic expansions coming from subjacent layers. When irradiated, a strong GABA staining appears around pycnotic cells as a network with labelled meshes. GABA staining and pycnotic cells were more especially important when the irradiation increases. Further studies are needed to specify the nature of labelled meshes.

In the normal hippocampal formation, subgranular cells are not GABA stained. Staining occurs in cells which are not granule cells. They are scattered throughout cell layers of the dentate gyrus with predominance in the hilus. After irradiation, GABA repartition is not modified.

After a 4 Gy whole body gamma irradiation, the inhibitory GABA system is not injured. Other amino-acid neurotransmitters such as Glutamate could be modified.

address: Mrs F. Ménétrier, CEN-FAR, DSV/DPTE, BP6,
92265 Fontenay-aux-Roses cedex, France.
FAX: (1) 46-54-91-80

GUIDELINES FOR EXPOSURE TO SUB-RADIOFREQUENCY ELECTRIC AND MAGNETIC FIELDS

David H. Sliney¹ and Robert M. Patterson²

¹Laser Microwave Division, US Army Environmental Hygiene Agency, Aberdeen Proving Ground, MD 21010-5422, USA ²College of Engineering, Temple University, Philadelphia, PA 19122, USA

Introduction

The International Non-Ionizing Radiation Committee (INIRC) of IRPA and the American Conference of Governmental Industrial Hygienists (ACGIH) have recommended guidelines for exposure limits (ELs) for sub-radiofrequency (sub-RF, defined as 30 kHz and less) electric and magnetic fields. The ACGIH refers to ELs as "Threshold Limit Values," or TLVs, and limits its guidance to the workplace.

Separate ELs are established for the electric and magnetic components of sub-RF electromagnetic fields because exposures of practical interest occur in the "near zone," where the two components behave independently.

Background

The SI unit for the electric field strength, E , is the volt per meter, V/m, while the magnetic flux density, B , is described by the tesla (T). The background static electric field is about 130 V/m, while oscillating fields range up to about 1000 V/m (20 kV/m during thunderstorms) with frequencies up to about 1000 Hz. Amplitudes generally decrease with increasing frequency. The typical atmospheric field at 50-60 Hz is only about 10^{-4} V/m.⁽¹⁾ Man produces sub-RF fields primarily from electric power generation, transmission, and use. Fields are typically about 10 kV/m directly under the conducting wires of transmission lines and 1 or 2 kV/m at the edge of the line right-of-way. By contrast, electric fields from building wiring and electrical appliances typically range only up to 100 V/m. Visual display terminals (VDTs) can produce fields of about 10 V/m or less at 10-15 kHz, due to the high-voltage circuit flyback transformer.⁽⁵⁾

The earth's static magnetic field is about 50 μ T. Power-frequency flux densities of about 10 μ T can occur very near electrical appliances. The home has levels of about 0.1 μ T. Some occupational environments, such as those where induction heaters are in use, may have flux densities of 10-100 mT.

Dosimetry and Measurement

Guidance on measuring power-frequency fields has been developed.⁽⁷⁾ Portable monitors, from simple spot measuring devices to dosimetric devices with on-board computers, are finding increasing use in epidemiologic studies.

Field Effects in Man

Sub-RF electric fields can induce fields and currents within the body. Hair vibration or other sensory stimuli may occur in fields greater than 10 kV/m. Currents induced in metal structures may produce shocks when humans contact the structure and permit a path to ground.

A grounded person in an electric field experiences a short-circuit current of approximately $I = 15 \times 10^{-8} f W^{2/3} E_0$, where I is in μA , f is the frequency in Hz, W is the weight in grams, and E_0 is the electric field strength in V/m.⁽⁶⁾ Thus, a 70 kg person would have a total short-circuit current of about 153 μA in a 10 kV/m, 60-Hz field. Studies of models indicate that current densities induced in a grounded, erect person exposed to a 10 kV/m, 60-Hz vertical electric field are 0.55 $\mu\text{A}/\text{cm}^2$ through the neck and 2 $\mu\text{A}/\text{cm}^2$ through the ankles.

Time-varying magnetic fields induce electric currents directly as the magnetic flux density and the frequency of oscillation, and inversely as the radius of the current loop. The current density at the perimeter of an adult torso can be approximated by $J = 0.24 f B_0$, where J is in A/m^2 , f is in Hz, and B_0 is in T. The maximum current density induced by normal residential field levels is thus of the order of 1 $\mu\text{A}/\text{m}^2$.

Biological Effects

Biological effects from sub-RF electric and magnetic fields have been demonstrated by in vitro and in vivo laboratory studies. However, no convincing studies have demonstrated adverse health effects. Moreover, a great many studies have led to findings of no effects. The many excellent reviews⁽¹⁻⁴⁾ offer a comprehensive discussion.

Human Studies

Occupational health effects of electric fields have been studied mainly in electric utility workers. Again, the references⁽¹⁻⁴⁾ contain excellent summaries of these.

A number of epidemiologic studies have identified an increased risk of cancer among those employed in "electrical occupations," such as electricians, engineers, or radio repairmen. The associations were not consistent among the studies, which often involved small numbers of cases.⁽¹⁾ Other deficiencies of these studies are stated in the report.

A more recent review⁽⁹⁾ considered eleven separate studies of electrical workers. The most consistent finding was a small increase in the risk of leukemia. The authors warned that the results are equivocal with respect to cause, because electrical workers are also exposed to agents besides fields, some of which may be leukemogenic. In contrast, a case-control study of deaths due to primary brain cancer or leukemia found an increased risk of brain cancer but no

increased risk of leukemia among electrical workers.⁽¹⁰⁾

Occupational studies are underway now (1992) in the U.S., Canada, and other countries. Results will become available over the next few years.

The Basis for Exposure Guidelines

Although there is little hard evidence for adverse effects from sub-RF fields, the growing concerns of workers and the public have prompted both INIRC and ACGIH to set guidelines.

Both groups developed guidance by limiting induced current densities in the body to levels that occur normally, i.e., up to about 10 mA/m² (higher levels can also occur naturally in the heart). Certain biological effects have been demonstrated in laboratory studies at field strengths below those permitted by the exposure guidelines; however, there is no convincing evidence now that occupational exposure to these field levels leads to adverse health effects.⁽²⁾

The INIRC Guideline ELs

The INIRC recommended electric field exposure limits of 10 kV/m for a whole working day with a short-term limit of 30 kV/m.⁽⁸⁾ Interim times and field strengths are related by the formula, $t = 80/E$, where t is in hours and E is in kV/m. The limits for magnetic flux density for occupational exposure were set at 0.5 mT for the entire workday, 5 mT for exposures of two hours or less, and 25 mT for exposure to limbs.

The ACGIH TLVs

The ACGIH TLV⁽¹¹⁾ for occupational exposure to sub-RF electric fields limits exposure to 25 kV/m for frequencies from 0 Hz to 100 Hz. For frequencies of 100 Hz to 4 KHz, the TLV is given by

$$E_{TLV} = 2.5 \times 10^6 / f \quad (\text{V/m, r.m.s.})$$

where f is in Hz. A limit of 625 V/m applies to frequencies from 4 kHz to 30 kHz. Because electromagnetic interference may occur in some models of heart pacemaker in power-frequency electric fields as low as 2 kV/m, exposures of workers with pacemakers are limited to 1 kV/m.

The TLV for sub-RF magnetic fields was revised in 1992 to be in consonance with the American National Standards Institute at frequencies above 300 Hz. For fields from 1 to 300 Hz, routine occupational exposure is limited to

$$B_{TLV} = 60 / f \quad (\text{mT, r.m.s.})$$

where f is the frequency in Hz. The TLV at 60 Hz is thus 1 mT. For frequencies from 300 Hz to 30 kHz, the TLV is 0.2 mT, which corresponds to a magnetic field strength of 163 A/m.

Below 1 Hz, the TLV is 60 mT.

References

1. World Health Organization Environmental Health Criteria 35: Extremely Low Frequency (ELF) Fields. WHO, Geneva, Switzerland (1984).
2. World Health Organization Environmental Health Criteria 69: Magnetic Fields. WHO, Geneva, Switzerland (1987).
3. American Institute of Biological Sciences: Biological and Human Health Effects of Extremely Low Frequency Electromagnetic Fields: Post 1977 Literature Review. AIBS, Arlington, VA (1985).
4. U.S. Congress, Office of Technology Assessment: Biological Effects of Power Frequency Electric and Magnetic Fields - Background Paper, OTA-BP-E-53. U.S. Government Printing Office, Washington, DC (May 1989).
5. Fatterson R.M., Hitchcock R.T., Non-Ionizing Radiation and Fields. Health and Safety Beyond the Workplace, Chapter 8. L.V. Cralley; et al., Eds. John Wiley and Sons, Inc., New York (1990).
6. Tenforde T.S., Kaune W.T., Interaction of Extremely Low Frequency Electric and Magnetic Fields With Humans. *Health Physics* 53:585-606 (1987).
7. The Institute of Electrical and Electronics Engineers, Inc.: Recommended Practices for Measurement of Electric and Magnetic Fields from AC Power Lines. IEEE Std 644-1979. IEEE, New York (1979).
8. International Non-ionizing Radiation Committee of the International Radiation Protection Association: Interim Guidelines on Limits of Exposure to 50/60 Hz Electric and Magnetic Fields. *Health Physics* 58:113-122 (1990).
9. Coleman M, Beral V, A Review of Epidemiological Studies of the Health Effects of Living Near or Working with Electricity Generation and Transmission Equipment. *International Journal of Epidemiology* 17:1-13 (1988).
10. Loomis D.P., Savitz D.A., Mortality from brain cancer and leukaemia among electrical workers. *British Journal of Industrial Medicine* 47:633-638 (1990).
11. "1991-1992 Threshold Limit Values," American Conference of Governmental Industrial Hygienists, Cincinnati, OH (1991).

GUIDELINES FOR EXPOSURE TO SUB-RADIOFREQUENCY ELECTRIC AND MAGNETIC FIELDS

David H. Sliney¹ and Robert M. Patterson²

¹Laser Microwave Division, US Army Environmental Hygiene Agency, Aberdeen Proving Ground, MD 21010-5422, USA ²College of Engineering, Temple University, Philadelphia, PA 19122, USA

Introduction

The International Non-Ionizing Radiation Committee (INIRC) of IRPA and the American Conference of Governmental Industrial Hygienists (ACGIH) have recommended guidelines for exposure limits (ELs) for sub-radiofrequency (sub-RF, defined as 30 kHz and less) electric and magnetic fields. The ACGIH refers to ELs as "Threshold Limit Values," or TLVs, and limits its guidance to the workplace.

Separate ELs are established for the electric and magnetic components of sub-RF electromagnetic fields because exposures of practical interest occur in the "near zone," where the two components behave independently.

Background

The SI unit for the electric field strength, E , is the volt per meter, V/m, while the magnetic flux density, B , is described by the tesla (T). The background static electric field is about 130 V/m, while oscillating fields range up to about 1000 V/m (20 kV/m during thunderstorms) with frequencies up to about 1000 Hz. Amplitudes generally decrease with increasing frequency. The typical atmospheric field at 50-60 Hz is only about 10^{-4} V/m.⁽¹⁾ Man produces sub-RF fields primarily from electric power generation, transmission, and use. Fields are typically about 10 kV/m directly under the conducting wires of transmission lines and 1 or 2 kV/m at the edge of the line right-of-way. By contrast, electric fields from building wiring and electrical appliances typically range only up to 100 V/m. Visual display terminals (VDTs) can produce fields of about 10 V/m or less at 10-15 kHz, due to the high-voltage circuit flyback transformer.⁽⁵⁾

The earth's static magnetic field is about 50 μ T. Power-frequency flux densities of about 10 μ T can occur very near electrical appliances. The home has levels of about 0.1 μ T. Some occupational environments, such as those where induction heaters are in use, may have flux densities of 10-100 mT.

Dosimetry and Measurement

Guidance on measuring power-frequency fields has been developed.⁽⁷⁾ Portable monitors, from simple spot measuring devices to dosimetric devices with on-board computers, are finding increasing use in epidemiologic studies.

Field Effects in Man

Sub-RF electric fields can induce fields and currents within the body. Hair vibration or other sensory stimuli may occur in fields greater than 10 kV/m. Currents induced in metal structures may produce shocks when humans contact the structure and permit a path to ground.

A grounded person in an electric field experiences a short-circuit current of approximately $I = 15 \times 10^{-8} f W^{2/3} E_0$, where I is in μA , f is the frequency in Hz, W is the weight in grams, and E_0 is the electric field strength in V/m.⁽⁶⁾ Thus, a 70 kg person would have a total short-circuit current of about 153 μA in a 10 kV/m, 60-Hz field. Studies of models indicate that current densities induced in a grounded, erect person exposed to a 10 kV/m, 60-Hz vertical electric field are 0.55 $\mu\text{A}/\text{cm}^2$ through the neck and 2 $\mu\text{A}/\text{cm}^2$ through the ankles.

Time-varying magnetic fields induce electric currents directly as the magnetic flux density and the frequency of oscillation, and inversely as the radius of the current loop. The current density at the perimeter of an adult torso can be approximated by $J = 0.24 f B_0$, where J is in A/m^2 , f is in Hz, and B_0 is in T. The maximum current density induced by normal residential field levels is thus of the order of 1 $\mu\text{A}/\text{m}^2$.

Biological Effects

Biological effects from sub-RF electric and magnetic fields have been demonstrated by in vitro and in vivo laboratory studies. However, no convincing studies have demonstrated adverse health effects. Moreover, a great many studies have led to findings of no effects. The many excellent reviews⁽¹⁻⁴⁾ offer a comprehensive discussion.

Human Studies

Occupational health effects of electric fields have been studied mainly in electric utility workers. Again, the references⁽¹⁻⁴⁾ contain excellent summaries of these.

A number of epidemiologic studies have identified an increased risk of cancer among those employed in "electrical occupations," such as electricians, engineers, or radio repairmen. The associations were not consistent among the studies, which often involved small numbers of cases.⁽¹⁾ Other deficiencies of these studies are stated in the report.

A more recent review⁽⁹⁾ considered eleven separate studies of electrical workers. The most consistent finding was a small increase in the risk of leukemia. The authors warned that the results are equivocal with respect to cause, because electrical workers are also exposed to agents besides fields, some of which may be leukemogenic. In contrast, a case-control study of deaths due to primary brain cancer or leukemia found an increased risk of brain cancer but no

increased risk of leukemia among electrical workers.⁽¹⁰⁾

Occupational studies are underway now (1992) in the U.S., Canada, and other countries. Results will become available over the next few years.

The Basis for Exposure Guidelines

Although there is little hard evidence for adverse effects from sub-RF fields, the growing concerns of workers and the public have prompted both INIRC and ACGIH to set guidelines.

Both groups developed guidance by limiting induced current densities in the body to levels that occur normally, i.e., up to about 10 mA/m² (higher levels can also occur naturally in the heart). Certain biological effects have been demonstrated in laboratory studies at field strengths below those permitted by the exposure guidelines; however, there is no convincing evidence now that occupational exposure to these field levels leads to adverse health effects.⁽²⁾

The INIRC Guideline ELs

The INIRC recommended electric field exposure limits of 10 kV/m for a whole working day with a short-term limit of 30 kV/m.⁽⁸⁾ Interim times and field strengths are related by the formula, $t = 80/E$, where t is in hours and E is in kV/m. The limits for magnetic flux density for occupational exposure were set at 0.5 mT for the entire workday, 5 mT for exposures of two hours or less, and 25 mT for exposure to limbs.

The ACGIH TLVs

The ACGIH TLV⁽¹¹⁾ for occupational exposure to sub-RF electric fields limits exposure to 25 kV/m for frequencies from 0 Hz to 100 Hz. For frequencies of 100 Hz to 4 KHz, the TLV is given by

$$E_{TLV} = 2.5 \times 10^6 / f \quad (\text{V/m, r.m.s.})$$

where f is in Hz. A limit of 625 V/m applies to frequencies from 4 kHz to 30 kHz. Because electromagnetic interference may occur in some models of heart pacemaker in power-frequency electric fields as low as 2 kV/m, exposures of workers with pacemakers are limited to 1 kV/m.

The TLV for sub-RF magnetic fields was revised in 1992 to be in consonance with the American National Standards Institute at frequencies above 300 Hz. For fields from 1 to 300 Hz, routine occupational exposure is limited to

$$B_{TLV} = 60 / f \quad (\text{mT, r.m.s.})$$

where f is the frequency in Hz. The TLV at 60 Hz is thus 1 mT. For frequencies from 300 Hz to 30 kHz, the TLV is 0.2 mT, which corresponds to a magnetic field strength of 163 A/m.

Below 1 Hz, the TLV is 60 mT.

References

1. World Health Organization Environmental Health Criteria 35: Extremely Low Frequency (ELF) Fields. WHO, Geneva, Switzerland (1984).
2. World Health Organization Environmental Health Criteria 69: Magnetic Fields. WHO, Geneva, Switzerland (1987).
3. American Institute of Biological Sciences: Biological and Human Health Effects of Extremely Low Frequency Electromagnetic Fields: Post 1977 Literature Review. AIBS, Arlington, VA (1985).
4. U.S. Congress, Office of Technology Assessment: Biological Effects of Power Frequency Electric and Magnetic Fields - Background Paper, OTA-BP-E-53. U.S. Government Printing Office, Washington, DC (May 1989).
5. Fatterson R.M., Hitchcock R.T., Non-Ionizing Radiation and Fields. Health and Safety Beyond the Workplace, Chapter 8. L.V. Cralley; et al., Eds. John Wiley and Sons, Inc., New York (1990).
6. Tenforde T.S., Kaune W.T., Interaction of Extremely Low Frequency Electric and Magnetic Fields With Humans. *Health Physics* 53:585-606 (1987).
7. The Institute of Electrical and Electronics Engineers, Inc.: Recommended Practices for Measurement of Electric and Magnetic Fields from AC Power Lines. IEEE Std 644-1979. IEEE, New York (1979).
8. International Non-ionizing Radiation Committee of the International Radiation Protection Association: Interim Guidelines on Limits of Exposure to 50/60 Hz Electric and Magnetic Fields. *Health Physics* 58:113-122 (1990).
9. Coleman M, Beral V, A Review of Epidemiological Studies of the Health Effects of Living Near or Working with Electricity Generation and Transmission Equipment. *International Journal of Epidemiology* 17:1-13 (1988).
10. Loomis D.P., Savitz D.A., Mortality from brain cancer and leukaemia among electrical workers. *British Journal of Industrial Medicine* 47:633-638 (1990).
11. "1991-1992 Threshold Limit Values," American Conference of Governmental Industrial Hygienists, Cincinnati, OH (1991).

ON THE BOUNDARY BETWEEN IONIZING AND NON-IONIZING RADIATION

Lars Persson

Swedish Radiation Protection Institute
Box 60204, S-10401 Stockholm, Sweden

ABSTRACT

The recent Radiation Protection Act of Sweden applies for the protection of people, animals and environment against the harmful effects of both non-ionizing and ionizing radiation. There are, however, a few differences in the obligations etc. in the Act for the two types of radiation. Some detailed physical and biological arguments are given here for use of the wavelength 100 nm as the practical boundary between the two types of radiation in the legislation.

INTRODUCTION

The recent Radiation Protection Act of Sweden (1) applies for the protection of people, animals and environment against the harmful effects of both non-ionizing and ionizing radiation. There are, however, a few differences in the obligations etc. in the Act for the two types of radiation. Thus in the preparatory work for the legislation it was necessary to define the boundary between the non-ionizing and the ionizing radiation. The Swedish Government's consultative commission for the preparation of the Act argued for a 100 nm photon wavelength corresponding to 12.4 eV as the boundary between the two types of radiation. The Swedish Government and the consulted authorities had no objections to this proposal and since the Act has now been passed by the Swedish Parliament the 100 nm boundary has been established in Sweden. Below some physical, chemical and biological arguments will be given for the use of 100 nm as the boundary between the two types of radiation in radiation protection legislation.

DEFINITION OF IONIZING RADIATION

The International Commission on Radiation Units and Measurement (ICRU) has given the following definition of the term ionizing radiation (2): "Ionizing radiation consists of charged particles or uncharged particles (e.g. photons) capable of causing ionization by primary or secondary processes". It is also noted by ICRU that a radiation, such as low energy photons, may be ionizing in one medium but not in another. Hence, the choice of a suitable energy cutoff, below which a radiation is considered as non-ionizing, will depend on the circumstances. In this work the author will discuss the cutoff energy for the human body.

PREVIOUS WORKS

Irradiation of living human cells with photons e.g. from a synchrotron light source in the relevant region of 100 nm has, according to the present author's knowledge, not yet

been performed. However, Hutchinson (3) found in an experiment for the inactivation of bovine serum albumin using a slow-electron beam of the appropriate energies that at some electron energy in the range 10-13 eV, with increasing energy, a process occurs which is much more likely to cause inactivation than that caused by ultraviolet ionization of lower energies. From the amount of energy involved he argues that it seems natural to identify this second process with ionization.

Setlow (4) has studied the effects of different wavelengths of ultraviolet light on nucleic acids and proteins. He observes at 121.5 nm with decreasing wavelength that the inactivation cross section of chymotrypsin increases much more rapidly than the absorption cross section. He noted in his paper that it is tempting to ascribe this large increase in quantum yield to the onset of ionization.

CALCULATIONS

The reference man with a weight of 70 kg consists of 15 elements with a quantity of 1.0 g or more (5). The ionization energies of these 15 elements vary from 4.3 eV for K to 17.4 eV for F (6). A mean value of the ionization energy, weighted according to the amount of these 15 elements in the reference man, is 12.9 eV corresponding to a photon wavelength of 96 nm.

DISCUSSION

As already mentioned there exist atoms in the human body with ionization energies much lower than 12.4 eV. For example the ionization energy 4.3 eV of K corresponds to a photon wavelength of 288 nm. However, the ionizing energy of K⁺ that you expect to find in biological systems is 31.8 eV corresponding to 45 nm.

The ionization potential of the isolated water molecule is 12.6 eV corresponding to a photon wavelength of 98 nm (7). However, there is also experimental evidence that at a quantum energy of only 6.8 eV corresponding to 185 nm some solvated electrons are formed (7). The reactive species of the irradiated water molecule may attack molecules in the cell leading to the production of biological damage yielding a highly reactive site on DNA in the form of a DNA radical (8). This is known as the indirect effect.

The DNA consists of atoms of H, C, N, O and P. The P atoms (approximately 10 weight percent of DNA) have an ionization energy of only 11.0 eV corresponding to a photon wavelength of 113 nm. Thus there exist some arguments for a wavelength longer than 100 nm as the boundary between ionizing and non-ionizing radiation.

The Swedish legal boundary between ionizing and non-ionizing radiation was established as 100 nm (or 12.4 eV) with the argument that it corresponds approximately to the upper wavelength limit for the production by photons of ionization in biologically important elements in the human body. This is by

the so-called direct effect (8). The World Health Organization has in its survey of protection against non-ionizing radiation (9) chosen a similar boundary between ionizing and non-ionizing radiation.

CONCLUSIONS

The 100 nm electromagnetic wavelength boundary established in connection with the adoption of the Swedish radiation protection Act may well in the field of radiation protection serve as a practical boundary between ionizing and non-ionizing radiation. However, there also exist some scientific arguments for a somewhat higher value. The data also indicate that there may be no sharp transition between ionizing and non-ionizing radiation.

An experimental investigation of the effects of photons on living, preferably human, cells in the boundary region approximately 10-400 nm, for example using synchrotron light should be valuable in the investigation of the problem.

REFERENCES

1. Persson, L., 1990, Radiation Protection Legislation in the Nordic Countries, SSI-Report 90-13, Swedish Radiation Protection Institute, Stockholm.
2. International Commission on Radiation Units and Measurements, 1980, Radiation quantities and units, ICRU Report 33, p. 4, Washington, D.C.
3. Hutchinson, F., 1954, Energy Requirements for the Inactivation of Bovine Serum Albumin by Radiation, Radiation Research 1, 43-54.
4. Setlow, R., 1960, Ultraviolet Wave-Length-Dependent effects on Proteins and Nucleic Acids, Radiation Research, Supplement 2, 276-289.
5. International Commission on Radiological Protection, 1975, Report of the Task Group on Reference Man, ICRP Publication 23, pp. 327-328, Pergamon Press, Oxford, New York, Toronto, Sydney, and Braunschweig.
6. Nordling, C. and Oesterman, J., 1987, Physics Handbook, 4th ed., pp. 65-69, Chartwell-Bratt Ltd, Bromley, England.
7. Stein, G., 1967, Excitation and ionization. Some correlations between the photo and radiation chemistry of liquids, Proceedings of a Conference on Radiation Chemistry and Photochemistry 21-23 September 1966 at University of Newcastle upon Tyne, Taylor & Francis Ltd, London, Editors: Johnson, G.R.A. and Scoles, G.
8. BEIR V, 1990, Health effects of exposure to low levels of ionizing radiation, pp. 12-13, National Academy Press, Washington D.C.

9. World Health Organization, Regional Office for Europe, 1982, Nonionizing Radiation Protection, WHO regional publications, European series, No 10, Copenhagen.

ACKNOWLEDGEMENTS

My thanks go to Professor emeritus H.H. Rossi, Columbia University, Irvington, New York, who kindly informed me of two relevant references, to Professor M. Almgren, Department of Physical Chemistry, University of Uppsala, Sweden for information on the photochemistry of water, to Dr M.C. Suess, WHO Regional Office for Europe in Copenhagen for comments on the WHO work, and to Dr A. Enflo, Swedish Radiation Protection Institute and Dr B. Cedervall, Department of Radiobiology, Karolinska Institute for many helpful discussions. I am also very grateful to Mr C Wilson for language corrections.

BASIC CRITERIA FOR ELF-STANDARDS

J.H. Bernhardt

Institute for Radiation Hygiene,
Federal Office for Radiation Protection
D 8042 Munich - Neuherberg

ABSTRACT

Since possible late effects resulting from ELF-field exposure have not definitely been proven standards are based on acute effects. The established basic limits (i.e. induced current densities) and derived limits (i.e. electric and magnetic field strengths) are summarized. Additionally, contact currents, interferences with medical implants and field perception must be considered for establishing intervention levels, especially, with regard to the aspects of preventive public health care.

INTRODUCTION

Though several epidemiological studies suggest, that a weak association exists between the exposure to ELF-fields and an increase of various kinds of cancer, a final risk assessment of long-term continuous exposure to ELF-fields is so far not possible. It has not definitely been proven, that the electric and magnetic ELF-fields occurring at working places or in every-day life are mutagenic or cancerogenic. The main critical points are concerning statistical evaluation, the insufficient determination of the field strength during the exposure and dose-effect relationships, furthermore, the inadequacy in the demarcation of concomitant factors and the absence of known interaction mechanisms. The final clarification of the question of possible late effects requires further elucidation. Therefore, for deriving standards, the non-stochastic ELF-field effects are well in the foreground ^{1,2}.

ACUTE FIELD EFFECTS

Electric and magnetic ELF-fields can generate - due to different interaction mechanisms - electric field strengths (in V/m) and electric current densities (in mA/m²) within the body. These tissue field strengths and current densities can produce - dependent on their intensity - biological effects. Although the electric tissue field strength is the basic quantity responsible for the biological effects, in most cases dose-effects-relationships are given in terms of the current density. Both of these quantities are connected via the electric conductivity.

No biological effects are scientifically confirmed so far below about 1 mA/m². Current densities between 1 and 10 mA/m² are corresponding to the endogenous background level of current densities in most organs and tissues of the body ^{2,3}. On the surface of electrically active nerve or muscle cells current densities of up to 1000 mA/m² can occur for short times.

From in-vitro laboratory studies using current densities between about 1 and 10 mA/m² some minor biological effects have

been reported. Some of these effects were observed only at distinct frequencies and field strengths ("windows"). Examples include changes in the calcium-efflux from preparations of brain-tissue following exposure of 16 Hz-electric or magnetic fields, modified calcium - uptake of lymphocytes following magnetic field exposure, and inhibition of melatonin synthesis by the pineal gland following exposure to weak static magnetic fields. The significance of these findings with human beings is not clear.

ELF-fields of relatively high intensity, producing internal body current densities exceeding about 10 mA/m², can cause some biological effects which cannot be ignored. Examples are enhancement of DNA synthesis, alteration of the molecular weight distribution during protein synthesis, delay of the mitotic cell cycle, blocking of the action of parathyroid hormone at the site of its plasma membrane receptor, and inhibition of the cytotoxicity of T-lymphocytes.

A systematic evaluation of the actually induced currents and field strengths at the tissue and cellular level of these findings is complicated by the following facts:

- large variations of the exposure conditions and,
- lack of details on the geometry of the biological samples.

Furthermore, the lack of reproducible results between different laboratories limit the interpretation. Since dose-response relationships have not yet been identified, systematic determinations of threshold values for tissue field strengths are urgently needed.

Controlled laboratory studies on volunteers exposed for short periods to electric field strengths up to 20 kV/m or magnetic flux densities up to 5 mT revealed no adverse clinical or significant physiological changes. These data do not exclude that health effects may occur by long term exposure. The thresholds for stimulation of excitable cells are above 100 mA/m²; for frequencies above about 300 Hz these thresholds increase proportionally with the frequency¹.

In addition to effects caused by induced tissue field strengths, there exist surface effects due to electric field exposure resulting in sensory perception and, furthermore, perception of transient or steady electric currents occurring from touching charged objects in electric fields. At 50/60 Hz a field strength of 20 kV/m is the perception threshold of 50% of people for sensations from their head hair or of tingling between body and clothes. A small percentage of people can perceive a field strength of 2 to 3 kV/m. The effects of steady or transient ("spark discharges") contact currents are depending on many factors, e.g., the size and geometry of the object, the electric field strength, the body impedance, the size of the contact area and the strength and duration of the contact current¹. Typical electric field strength levels leading to spark discharges which are felt as an annoyance in our daily environment are between 2 and 7 kV/m. A small percentage of people can perceive a field strength of .5 kV/m via spark discharges.

A further group of indirect effects result from possible effects of ELF-fields on electric or electronic implanted medical devices. Typical example is the implanted pacemaker.

BASIC AND DERIVED EXPOSURE LIMITS

For establishing exposure limits and safety factors, duration of exposure, presence of controlled or uncontrolled environments, existence of risk groups (e.g. with medical implants) should be considered. The evaluation of the acute effects have lead to recommendations of exposure limits which are different for occupationally exposed persons and the general public.

The International Non-Ionizing Radiation Committee (INIRC) of IRPA recommends that the ELF field induced current density should not exceed 10 mA/m^2 in the body². Since most evidence is based on short term observations and, since there is a limited knowledge of the possible effects of long term exposure, the INIR Committee recommends to limit of induced current density to 4 mA/m^2 for the continuous occupational exposure and 2 mA/m^2 for the general public (a factor of 5 below 10 mA/m^2). The current densities should be averaged over a period of 1 s and a cross-section of 1 cm^2 perpendicular to the current direction. This averaging seems to be sufficient for picking up spatial and temporal peak values, in view of the fact that the effects of current densities are occurring at the cellular levels, that a plurality of cellular effects are resulting in an action on the whole organisation and, furthermore, the safety zone from stimulating effects are sufficiently large.

From these basic restrictions for the current density the dosimetric quantities, which are necessary for practical purposes, must be derived. The derived secondary exposure limits, i.e., the external electric and magnetic field strengths must be deducted in such a way, that the protective aim is guaranteed also under worst case conditions. For the derivation of field strength exposure limits from the basic restriction there exist numerical and measuring methods. For both methods considerable simplifications were used up to now not taking into account, i.e., the inhomogeneous distribution and anisotropy of the electric conductivity. Due to such simplifications possible spatial increased values of the basic restriction remain disregarded.

CONCLUSIONS

The table summarizes the results of measurements and calculations. The table reflects partially the heterogeneous distribution of the current density within the human body produced by external electric or magnetic fields. For example, an electric field strength of 5 kV/m (the IRPA/IRNIC recommendation for the limit of continuous exposure of the general public to 50/60 Hz electric fields) produces in trunk, head, neck and ankles current density of up to 1.7, 0.5, 2.5 and 10 mA/m^2 , respectively. A magnetic flux density of 0.1 mT induces in trunk, head and wrists/ankles current densities of up to 1.7, 0.4 and 0.15 mA/m^2 , respectively. A refinement of such model estimations, however, is urgently needed.

Table: Derived values for the electric field strength and magnetic flux density approximately producing a current density of 1 mA/m² in different body parts at 50 or 60 Hz.

Left: Values of the electric field strength;

Right: Values of the magnetic flux density (peripheral regions; R: Radius of current loop; a homogeneous conductivity of 0.2 S/m is assumed).

Electric field strength in kV/m				Magnetic flux density in mT		
Trunk (average)	Head	Neck	Ankles (both feet grounded)	Trunk (R=0.3m)	Head (R=0.075m)	Wrist/ Ankles (R=0.03m)
3	10	2	0.5	0.06	0.25	0.6

Generally, for the establishment of standards, the simultaneous occurrence of other physical agents, noxious chemicals or biologicals factors is not being considered. The exposure limit of 5 kV/m provides substantial protection for the public from annoyance caused by contact currents or transient discharges, which is considered acceptable for occupational exposed persons. For occupationally exposure, hazardous body currents and contact voltages must be avoided by special measures. An electric field strength of 5 kV/m, however, cannot completely eliminate perception of electric field effects. Additionally, there is a small probability that a malfunction of some sensitive unipolar cardiac pacemakers will occur under worst-case conditions at electric field strength values between 2.5 and 5 kV/m and magnetic flux densities between 0.02 and 0.1 mT. Furthermore, in view of this and some other unknowns and uncertainties concerning the complete understanding of the interacting mechanisms and the final clarification of possible long term effects it may be prudent not to exhaust the exposure limits. Such aspects of preventive public health care should be taken into consideration especially on developing new technologies by using electric energy or building transmission lines near public dwellings.

REFERENCES

1. Bernhardt, J.H., 1988. The establishment of frequency dependent limits for electric and magnetic fields and evaluation of indirect effects. *Radiat. Environ. Biophys.* 27, pp 1-27.
2. International Radiation Protection Association/International Non-Ionizing Radiation Committee, 1990. Interim guidelines on limits of exposure to 50/60 Hz electric and magnetic fields. *Health Physics* 58, pp 113-122.
3. United Nations Environment Programme/World Health Organization Radiation Protection Association, 1987. Environmental health criteria 69. Magnetic fields. Geneva: WHO

PROPOSAL FOR CHANGING THE LASER EXPOSURE LIMITS
FOR EXTENDED SOURCE VIEWING

D. Courant¹, D.H. Sliney², W. Marshall² and I. Court^{1,3}

¹ Commissariat à l'Energie Atomique, DSV-DPTE, Bp6, 92265 Fontenay aux
Roses France. ² Laser Microwave Division, US Army Environmental Hygiene
Agency, Aberdeen Proving Ground, MD 21010-5422 USA. ³ Centre de
Recherches du Service de Santé des Armées, Bp 87,
F-38702 La Tronche, France

ABSTRACT

The current laser safety standards have two sets of ocular exposure limits. One set concerns the intrabeam or point source viewing condition, the other a diffuse reflection or an extended laser source. Recent studies of retinal injury thresholds for large retinal image sizes at microsecond exposure times have shown that no safety factor exists in current laser standards for this exposure regime. From a complete review of known biological data, it was possible to develop a set of new exposure criteria that much more closely follow actual injury thresholds. The new proposal makes use of the fact that retinal injury thresholds vary inversely as image size, and limits can be expressed as an angular correction factor to the intrabeam "point-source" exposure limits.

INTRODUCTION

The IRPA and IEC laser safety recommendations have two sets of ocular exposure limits. One set relates to the intrabeam or point source viewing condition, the other to a diffuse reflection or an extended laser source. The latter, although seldom used is nevertheless important. The increasing power of lasers can induce hazardous reflections. New laser products, especially in recent investigative techniques of the retina and in retinal imagery, are ever more using extended sources or optics producing large retinal images.

Many biological data exist on damage thresholds for minimal retinal image sizes. No controversy concerning the threshold values has been reported. The experimental results are in good agreement with present exposure limits. At the opposite, for non-minimal images few experiments were performed to know the influence of the retinal image size and specify the corresponding laser injury thresholds. Problems appear when comparing the limit values and the biological data base for large image sizes.

PROBLEMS RAISED BY THE EXPOSURE LIMITS FOR EXTENDED SOURCE VIEWING.

The present exposure limits for viewing extended sources or diffuse reflections of laser radiation are a function of the exposure duration. For extended sources, the exposure limits are usually expressed in $W.cm^{-2}.sr^{-1}$ (radiance) and in $J.cm^{-2}.sr^{-1}$ (integrated radiance). For a given exposure duration, the integrated radiance limit specified at the cornea determines a corresponding retinal radiant exposure limit expressed in

$\text{J}\cdot\text{cm}^{-2}$. This limit value does not vary with the size of the retinal image. Thus, the corneal exposure limit determines the same invariable radiant exposure limit for every retinal spot size. By example, the retinal radiant exposure corresponding to the exposure limit (EL), is $10 \text{ mJ}\cdot\text{cm}^{-2}$ for viewing angles as different as 0.004 and 0.033 radian. However, the biological data have shown a dependence of the retinal lesion threshold on image size. What is the maximal image size taken into account by the standard? This is not specified for the present EL.

The use, in the most recent studies, of an investigative technique such as fluorescein angiography, has shown that the retinal damage thresholds are lower than those reported in the early experiments using a direct ophthalmoscopic method [1,2]. The results demonstrated that at the relevant limit value, there is a risk of lesion which can be detected by angiography for retinal spot sizes greater than $250 \mu\text{m}$. The risk or probability of detecting a damage is increasing with the retinal image diameter.

THE NEW PROPOSAL

From a complete review of known biological data, it was possible to develop a set of new exposure criteria that much more closely follow actual injury thresholds. The good agreement of the experimental data with the exposure limits for point source or intrabeam viewing can be used to specify in a better way the limits for extended source viewing. The regression lines, fitting the biological data obtained with different image sizes, are divided in two groups which depend on the exposure duration in the same way as the intrabeam viewing exposure limits. The relationship established between the retinal lesion threshold level (ED_{50}) and the retinal image diameter can be described by the relevant equation:

$$Hr = b \cdot r^m$$

where Hr is the retinal radiant exposure expressed in $\text{J}\cdot\text{cm}^{-2}$, r the retinal image diameter expressed in μm , m the slope of the line and b is a constant. The similarity of the slopes of the curves allows one to consider very roughly the spot size dependence as a function that is inversely proportional to the image diameter. The best fit to the data is obtained with slopes m of -0.8 to -1.2 . This is corroborated for exposure durations ranging from 10^{-9} s to 10 s [2].

The new proposal makes use of the fact that retinal injury thresholds vary inversely as image size, and limits can be expressed as an angular correction factor to the intrabeam "point-source" ELs. Using this relationship, the retinal radiant exposure corresponding to the limit EL for extended source viewing (H ELs) could be expressed as the corresponding radiant exposure for the point source limit value (H ELps) multiplied by a correction factor CF that includes an image size dependent term:

$$\text{New H ELs (for extended source)} = \text{H ELps (for point source)} \times \text{CF}$$

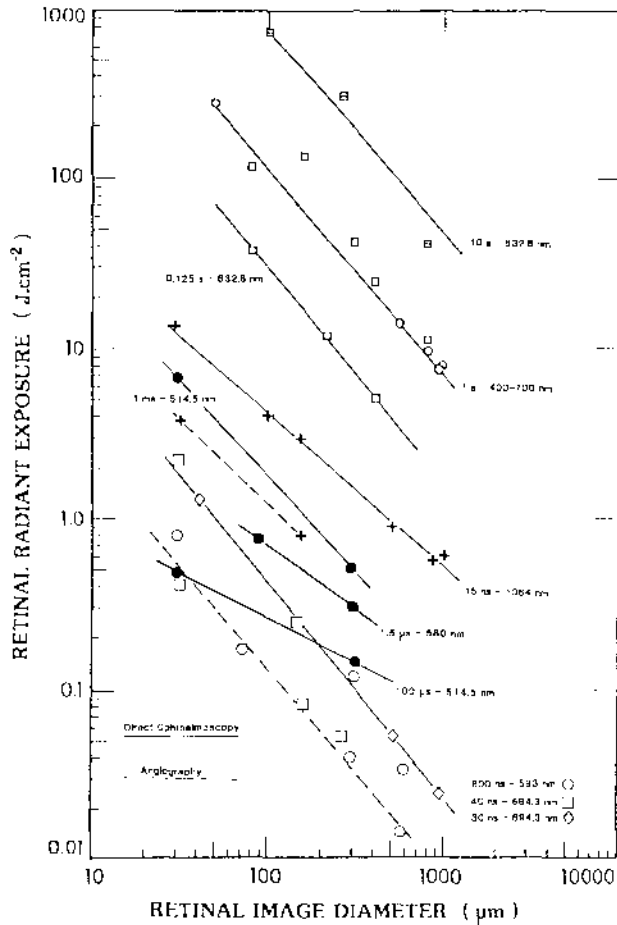

Figure 1. The relationship between the retinal damage threshold (ED_{50}) and the retinal spot-size.

The multiplicative correction factor CF can be expressed as follows:

$$CF = (\alpha / \alpha_{min})^m$$

where α is the angular subtense or visual angle of the extended source and α_{min} the limiting angle which determines extended source versus point source viewing condition. The value of the slope m is chosen 1.0. In the standard, α_{min} varies with the exposure duration, whereas in our

proposal α_{inj} is a fixed value in the thermal injury domain. It may be convenient to consider a value of α_{inj} equal to the lowest effective retinal image size formed on the retina but it may be too possible to choose a larger value of α_{inj} , at which the experimental data still warrant the exposure limits.

For exposure durations larger than 10 s, the effects of eye movements become dominant on the retinal spot-size. A good value for α_{inj} , based upon eye movements recordings for fixating a point seems 11 milliradians. A transition value of α_{inj} should be defined for exposure ranging from 1-3 s, when the eye movements begin to influence the retinal image diameter, to 10 s.

The recent thermal model calculations show that the 1/r spot-size dependance ends at about 1-2 mm retinal image diameter. Hence, a single radiance limit is possible for visual angle subtending the source corresponding to retinal image diameters larger than 1-2 mm. The visual angle specifying the use of a radiance limit could be defined by the new term α_{rad} .

This formulation allows one to specify safety margins for large image diameters equivalent to those existing for intrabeam viewing conditions. This revision effort also has implications for exposure limits applied to non-coherent light sources.

REFERENCES

1. Courant D., Court L., Abadie B. and Brouillet B., 1989, Retinal damage thresholds from single pulse laser exposures in the visible spectrum, Health phys., 56, pp. 637-642.
2. Courant D., Court L. and Sliney D.H., 1989, Spot-size dependence of laser retinal dosimetry in Dosimetry of Laser Radiation in Medicine and Biology, G. Müller and D.H. Sliney eds. published by SPIE Optical Engineering Press, Washington, 156-165.
3. Ham W.T. and Mueller R.A., 1987, . Applied optics, 26, pp. 3456-3460.
4. Delori F.C., Parker J.S. and Mainster M.A., 1980, Light levels in fundus photography and fluorescein angiography. Vision Res., 20, pp. 1099-1104.

**CURRENT AND PLANNED ACTIVITIES OF THE
IRPA - INTERNATIONAL NON-IONIZING RADIATION COMMITTEE**

A.S. Duchêne, INIRC Scientific Secretary,
32 rue Gambetta, 92260 Fontenay-aux-Roses, France

ABSTRACT

In its fifteen years existence, IRPA - INIRC has worked hard to achieve the objective that IRPA assigned to the Committee when creating it in 1977. The IRPA-INIRC Guidelines on limits of exposure now cover a large part of the electromagnetic spectrum as well as ultrasound and some of them have been updated in recent years. INIRC's activities since the last IRPA Congress in 1988, its work in progress and future programme are detailed below.

INTRODUCTION

As compared to ionizing radiation, non-ionizing radiation protection is a rather young matter of concern and IRPA-INIRC, the first international body specifically set up to this purpose, was created 50 years later than ICRP. For a long time health protection interests were mainly focussed on the nuclear industry. In recent years, however, the public has become increasingly aware of other factors of nuisance in its living and working environment, and NIR which is omnipresent in our everyday life is one of these. Public contests against planned or even existing NIR-emitting installations are developing and workers' concern about possible hazards from NIR has manifested itself in various industries. There is an increasing request for regulatory protection measures and guidance in this respect and the IRPA guidelines are being recommended or adopted in an increasing number of countries.

Non-ionizing radiation (NIR) refers to a wide range of radiations and fields with different physical characteristics and different processes of interaction with living matter. This requires that the composition of INIRC reflects appropriate expertise with respect to the different NIR and recognized competence within various disciplines. When considering the work achieved by INIRC since its creation, it must be borne in mind that its membership was limited to 12 members plus a Chairman and a Scientific Secretary, and for a long time was even less than that. For the last 4-year period, INIRC's membership included the following :

M.H. Repacholi, Chairman (Australia),
H.P. Jammet, Chairman Emeritus (France), J.H. Bernhardt (F.R.Germany),
B.F.M. Bosnjakovic (The Netherlands), L.A. Court (France), P.A. Czerski (U.S.A.), M. Grandolfo (Italy), B.G. Knave (Sweden), A.F. McKinlay (U.K.),
M.G. Shandala (U.S.S.R.), D.H. Sliney (U.S.A.), J.A.J. Stolwijk (U.S.A.),
M.A. Stuchly (Canada), L.D. Szabo (Hungary), A.S. Duchêne, Scientific Secretary (France).

Professor P. Czerski, charter member of INIRC, died in April 1990. He was a pioneer investigator in the effects of non-ionizing radiation on biosystems and a fervent promoter of international cooperation. With him, INIRC lost one of its most active members.

ACTIVITIES OF IRPA-INIRC.

INIRC's work up to 1988 has been reported in detail at the 7th International Congress of IRPA. Since then, INIRC carried on its activities in three directions, namely: the preparation of new guidelines for other parts of the NIR spectrum and of statements on questions of the moment; the analysis of background data relating to NIR in cooperation with the World Health Organization (WHO); and the development of practical guidance for protection against NIR at the workplace in cooperation with the International Labour Office (ILO).

In addition, INIRC contributed to the promotion of NIR protection through the organization or cosponsoring of Workshops (Melbourne, Australia, 1988; Vancouver, Canada, 1992) or International Courses on NIR (Erice, Italy, 1989).

IRPA-INIRC guidelines

New data on the biological effects and the relative spectral effectiveness in the UV-A region lead INIRC to revise its 1985 Guidelines on limits of exposure to ultraviolet radiation. The table of relative effectiveness values has been completed for the different wavelengths between 315 and 400 nm. Furthermore, it was felt that the former irradiance limit of 10 W m^{-2} for periods greater than 1000 s included an insufficient safety factor for longer periods. The revised exposure limits for the near UV spectral region, expressed in terms of radiant exposure (J m^{-2}), were published in Health Physics, vol. 56, June 1989.

Many specialists in the field of ultraviolet radiation have called attention to the long term health risks of excessive UV exposure. Following some concern about the potential hazard associated with fluorescent lighting, INIRC's conclusions that UVR exposure from indoor fluorescent lighting should not be considered a malignant melanoma risk were published in a statement on "*Fluorescent lighting and malignant melanoma*", Health Physics, vol. 58, January 1990. Despite many warnings, the populations living in temperate climates are still keen about suntanning. While voluntary exposure to the natural sun cannot be controlled, there is a real need to minimize the risks due to the use of artificial sunbeds and a statement to this purpose "*Health issues of ultraviolet 'A' sunbeds used for cosmetic purposes*" was published in Health Physics, vol. 61, August 1991.

INIRC's "*Interim guidelines on limits of exposure to 50/60 Hz electric and magnetic fields*" were published in Health Physics, vol. 58, January 1990. These guidelines deal with one of the presently most controversial issues in the field of NIR. The question in debate is whether extremely low levels of 50/60 Hz electric or magnetic fields (about $0.25 \mu\text{T}$) could induce an increased risk of occurrence of cancer or leukemia, although there is no proof of such a risk at high levels. INIRC's position in this respect, as stated in the guidelines, is: "The exposure limits are based on established or predicted effects of exposure to 50/60 Hz fields. Although some epidemiological studies suggest an association between exposure to 50/60 Hz fields and cancer, others do not. Not only is this association not proven, but present data do not provide any basis for health risk assessment useful for the development of exposure limits".

Magnetic resonance imaging and spectroscopy have become useful tools in clinical diagnostic. These techniques involve exposure of the patient to radiofrequency electromagnetic fields and to static and time-varying magnetic fields. A report dealing with "Protection of the patient undergoing a magnetic resonance examination" has been published in the December 1991 issue of Health Physics, vol. 61.

A few months ago, draft guidelines on limits of exposure to static magnetic fields have been distributed to IRPA Associate Societies for review. Depending on the comments received, these will be either finalized and approved or discussed again during the INIRC meeting in May 1992.

Finally, it is important to note that, for easier consultation, the INIRC guidelines and statements published in Health Physics up to end 1990 have been collected together in a single book issued by Pergamon Press in May 1991. The book is available to IRPA members at a special rate.

Environmental health criteria

Important advances in biological radiofrequency radiation research made it necessary to revise E.H.C.16 for Radiofrequency and Microwaves (1981). Therefore, a new E.H.C. document for Electromagnetic fields in the frequency range from 300 Hz to 300 GHz was prepared in cooperation with WHO and with funding from UNEP. The Environmental Health Directorate of the Health and Welfare of Canada kindly hosted and provided financial support for the international task group that met in Ottawa to review and complete the draft. The new UNEP/WHO/IRPA document is expected to be issued in 1992 in the WHO Environmental Health Criteria series.

Guidance for safe occupational practice

IRPA-INIRC collaborates with the ILO to provide guidance on working conditions and procedures that will lead to higher standards of safety in the workplace. After a report on protection against radiofrequency and microwave radiation published in 1986, ILO has asked INIRC to deal with further topics about which workers were concerned. At ILO's request the three following practical guides have been prepared :

- Practical guide on the protection of workers from power frequency electric and magnetic fields ;
- Visual Display Units - radiation protection guidance ;
- Practical guide on the use of lasers in the workplace.

These joint ILO/IRPA-INIRC publications will be published in the ILO Occupational Safety and Health Series.

Future programme of work

Environmental Health criteria documents. INIRC has submitted to WHO proposals for the revision of EHC 14 for Ultraviolet Radiation (1979) in priority, to be followed by the updating of EHC 22 for ultrasound (1982) and EHC 23 for lasers (1982).

Guidelines on limits of exposure. As a general rule, INIRC's guidelines are periodically revised to be kept in line with significant progress in scientific knowledge.

In the field of optical radiation, INIRC intends to develop guidelines on limits of exposure for visible and infrared radiation, and to amend the guidelines for lasers with respect to the exposure limits for extended sources.

Concerning electromagnetic fields, the guidelines should be completed over the frequency range between 0 and 10^5 Hz.

- *Guidance for safe operational practice.* INIRC feels that several topics should be dealt with, such as UV and infrared radiation for indoor workers, UV radiation for outdoor workers, and radiofrequency heating devices.

- *Joint project.* Considering the expanding use of NIR in medical technologies, it was found desirable that a Manual for the protection of health care workers against NIR be developed under the joint sponsorship of ILO, INIRC and WHO.

CONCLUSION

IRPA-INIRC has now gained international recognition in the field of protection against NIR and the IRPA-INIRC guidelines are known in all parts of the world. This would not have been achieved without the continuous and active support of the IRPA Executive Council and the IRPA members. INIRC is also grateful for the encouragement and support of national institutes and of international organizations and, in particular, of the World Health Organization, the United Nations Environment Programme, the International Labour Office and the Commission of the European Communities. INIRC has grown up and, to consolidate its international status, IRPA intends to give it a charter as a more independent body. If set up during the present Congress, the future International Commission on Non-Ionizing Radiation Protection (ICNIRP) will continue INIRC's work and still retain a special relationship with IRPA.

PUBLICATIONS

Non-Ionizing Radiations: Physical characteristics, biological effects and health hazard assessment. M.H. Repacholi, ed. IRPA-INIRC, 1988. Available: Australian Radiation Laboratory, Lower Plenty Road, Yallambie, Victoria, Australia 3085.

IRPA Guidelines on Protection against non-ionizing radiation. A.S. Duchêne, J.R.A. Lakey, M.H. Repacholi, eds. New York : Pergamon Press, 1991

**DÉVELOPPEMENT D'UN APPAREIL PORTATIF À LECTURE DIRECTE POUR
L'ÉVALUATION TRIAXIALE DES CHAMPS ÉLECTRIQUES ET MAGNÉTIQUES
AUX FRÉQUENCES EXTRÊMEMENT BASSES**

L. Laliberté, B. Caron, R. Sylvestre

**Groupe de métrologie des champs électromagnétiques
Secteur soutien analytique
Institut de Recherche en Santé et en Sécurité du travail du Québec (IRSSTQ)
Montréal (Québec)
Canada**

**DEVELOPMENT OF A PORTABLE DIRECT READING INSTRUMENT FOR
THE TRIAXIAL EVALUATION OF ELECTRIC AND MAGNETIC FIELDS
AT EXTREMELY LOW FREQUENCIES**

Concerned by the growing studies linking low frequency exposure and certain types of cancer and by the lack of a suitable direct reading instrument capable of analyzing specific frequencies, IRSSTQ has developed a portable direct reading microprocessor based instrument capable of measuring triaxially both electric and magnetic fields at any frequency in the 50 to 720 Hz range with a dynamic range of at least 70 db. The sensitivity of the instrument is 0.5 V/m and 10 nT. Accuracy is within $\pm 5\%$ and the bandwidth at 60 Hz is ± 2 Hz at - 60 db. At 720 Hz it is ± 41 Hz at - 60 db. In addition, the instrument has the capability of producing a printout of selected parameters via an RS-232 fibre optics port.

L'exposition à des champs électriques et magnétiques de basses fréquences préoccupe de plus en plus les spécialistes de la santé. Les ressources énergétiques du Québec sont abondantes et ont permis l'installation des industries qui consomment de grandes quantités d'énergie électrique. Les travailleurs qui oeuvrent dans ces industries et ceux qui voient à l'entretien des lignes de transport et de distribution d'électricité sont possiblement exposés à de forts champs électriques et magnétiques. Des études [1] laissent entrevoir la possibilité que ces champs soient des initiateurs ou des promoteurs de certains types de cancer ou du moins, qu'ils puissent interférer avec les mécanismes internes du corps [2], d'où l'intérêt grandissant pour l'évaluation de l'intensité de ces champs.

Il existe présentement des instruments de mesure sur le marché, mais la majorité de ces instruments n'évalue les champs que selon un seul axe, ce qui exige de la part de l'utilisateur une recherche de la lecture maximale par la rotation de la sonde. Ceci a pour conséquence de rendre ardues les mesures répétitives telles que la cartographie des champs en plus d'augmenter les risques d'erreur. De plus, les mesures à distance ne sont pas possibles avec de tels instruments. D'autres encore ne peuvent qu'évaluer une seule fréquence, généralement à 50 ou 60 Hz, ignorant tout des harmoniques supérieures qui sont souvent très élevées. Certains évaluent les intensités des champs sur une large bande ce qui nous empêche d'évaluer correctement l'exposition. En effet, l'American Conference of Governmental Industrial Hygienist (ACGIH) a récemment émis des recommandations [3] sur les champs électriques et magnétiques couvrant la plage de 0 à 30 kHz. Ces recommandations sont proportionnelles à la fréquence. Auparavant, seul un analyseur de spectre ou un voltmètre sélectif permettaient de telles mesures.

L'IRSSTQ a développé un appareil de mesure portatif à microprocesseur qui effectue la mesure triaxiale et sélective de l'intensité rms des champs électriques et magnétiques pour n'importe quelle fréquence située entre 50 et 720 Hz avec une gamme dynamique d'au moins 70 db. La sensibilité de cet instrument est de 0,5 V/m et 10 nT. La largeur de bande à 60 Hz est de $\pm 0,7$ Hz à un niveau de - 6 db et ± 2 Hz à un niveau de - 60 db et à 720 Hz elle est de ± 7 Hz à un niveau de - 6 db et ± 41 Hz à un niveau de - 60 db. L'exactitude est de $\pm 5\%$ de la lecture. De plus, l'appareil est muni d'une sortie RS-232 à fibre optique.

La figure 1 illustre un exemple de rapport que l'utilisateur peut obtenir de l'appareil.

POINT DE MESURE # 054

FREQ (Hz)	MAGX (tesla)	MAGY (tesla)	MAGZ (tesla)	TOTAL (tesla)	RECOMM (tesla)	J (A/m ²)	
60	+5.493E-03	+8.893E-04	+6.523E-03	+7.453E-03	+9.999E-04	+1.073E-01	*
120	+1.647E-04	+1.416E-04	+1.190E-04	+2.477E-04	+4.999E-04	+7.135E-03	
180	+1.134E-04	+3.982E-03	+2.396E-04	+3.991E-03	+3.333E-04	+1.724E-01	*
240	+7.906E-05	+6.799E-05	+5.714E-05	+1.189E-04	+2.499E-04	+6.849E-03	
300	+6.406E-05	+5.509E-05	+4.630E-05	+9.655E-05	+2.000E-04	+6.937E-03	
360	+5.364E-05	+4.613E-05	+6.933E-04	+6.969E-04	+1.666E-04	+6.022E-02	*
420	+4.510E-05	+5.065E-04	+4.129E-04	+6.550E-04	+1.428E-04	+6.603E-02	*
480	+7.825E-04	+7.985E-04	+2.793E-05	+1.118E-03	+1.249E-04	+1.288E-01	*
540	+3.458E-05	+2.974E-05	+2.499E-05	+5.201E-05	+1.111E-04	+6.740E-03	
600	+3.255E-04	+2.799E-05	+6.877E-05	+3.338E-04	+1.000E-04	+4.807E-02	*
660	+2.859E-05	+2.459E-05	+3.695E-04	+3.715E-04	+9.090E-05	+5.884E-02	*
720	+2.630E-05	+3.566E-04	+1.901E-05	+3.580E-04	+8.353E-05	+6.187E-02	*

FIGURE 1

CONCLUSION

Les essais sur le terrain ont été très encourageants, l'appareil rencontre nos objectifs initiaux. Vu la nature extrêmement fluctuante de certains champs, il est apparu nécessaire d'ajouter une fonction de moyenne et d'écart type afin d'obtenir des valeurs plus représentatives du milieu. L'ajout de paramètres de direction et de phase des champs permettront de mieux identifier l'origine des champs.

REPÉRENCES

- 1.- Silverman, C. Epidemiological Studies of Cancer and Electromagnetic Fields dans Biological Effects and Medical Applications of Electromagnetic Energy, Om P. Gandhi, editor. Prentice Hall, 1990, p 414 - 436.
- 2.- Anderson, L.E. Biological Effects of Extremely Low-Frequency and 60 Hz Fields dans Biological Effects and Medical Applications of Electromagnetic Energy. Om P. Gandhi, editor. Prentice Hall, 1990, p 196 - 235.
- 3.- American Conference of Governmental Industrial Hygienists. 1990-1991 Threshold Limit Values for Chemical Substances and Physical Agents and Biological Exposure Indices, Cincinnati, Ohio.

DOMESTIC MAGNETIC FIELDS

PROTOCOLS, MEASUREMENTS AND RESULTS

Authors:

Mr A T Wilson
Chief Engineer
Power Grid Development Department
State Electricity Commission of Victoria

Mr R J Owen
Fields and Investigations Engineer
Power Grid Development Department
State Electricity Commission of Victoria

ABSTRACT

The quantification of magnetic field exposure has been the subject of considerable debate. A number of surrogates have been used including, spot measurements, wire coding and 24 hour averages. The quantification of domestic magnetic fields including the identification of sources is important if any mitigation is required. The State Electricity Commission of Victoria has developed recording instrumentation and measurement protocols for the survey of domestic magnetic field strengths in the Melbourne area.

A range of domestic locations in the Melbourne metropolitan area is chosen to test the influence of external installations and the effect of appliance usage and energy consumption on the domestic magnetic field environment.

INTRODUCTION

The importance of residential magnetic fields has been the subject of considerable debate throughout the last decade. Several residential epidemiological studies of childhood cancer and magnetic fields suggested there may be an association, but the measures of exposure used were not entirely rigorous and criticised in several reviews.

The SECV has previously carried out a spot measurement survey of residential magnetic fields in the Melbourne metropolitan area and gained a good knowledge of the range of values involved. The magnetic fields debate has widened in its consideration of what it is that constitutes exposure. The equipment described below was designed to provide additional information regarding the variation, likely sources and level of residential fields.

SPOT MEASUREMENT SURVEY

This survey selected homes in the metropolitan area of Melbourne using a randomisation technique. The measurement protocol provided for measurements in each room and at common occupier locations. The measurements were taken under "high" load and "low" load conditions. These can be most simply described as the condition of the house during low activity of the occupants for low load and a typical evening meal time where lights are on and appliances operating for high load. Measurements were taken under the nearby street line and near the water meter.

The results of this survey showed that the energy consumption in the house had a significant effect on the magnetic field levels in the house. Histograms in Figures 1 and 2 show the distribution of magnetic field levels for each condition together with the average values for low and high load conditions.

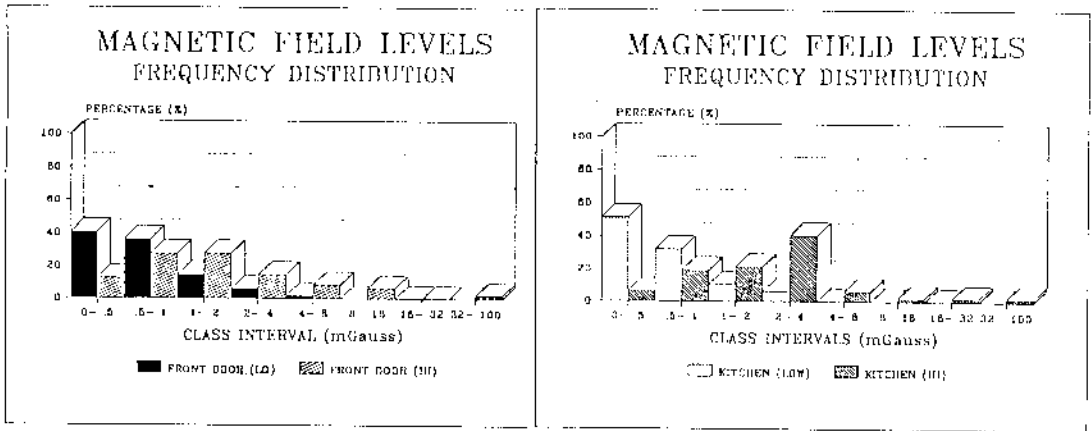

Figure 1 Effect of house energy usage on magnetic fields at the front door

Figure 2 Effect of house energy usage on the magnetic fields in the kitchen

Australia uses the Multiple earthed neutral system (MEN) for residential distribution of electricity. With this system the possibility exists for a fraction of the neutral return current to flow via earth. The influence of this current on the magnetic fields in the house is determined by the path of the current. To a great extent this is determined by the location and the type of the domestic water supply system used in that location and whether the MEN earth is bonded to the water pipe or not.

From a study of earth return currents it has been found that the majority of earth return current flows through the water and gas pipes. The magnitude of this current has been investigated in another project and estimated to be an average value of 5% of the household current.

INSTRUMENTATION DEVELOPMENT

The spot measurement survey using different house load conditions highlighted the need for knowledge of the range of variation of fields during normal activity in the house. Instrumentation was developed for this purpose. The requirements for the instrumentation included the need to record magnetic fields in up to three locations simultaneously and also record up to four currents. At each measuring point there are three coils mounted orthogonally and data is collected from each coil prior to combining to find the resultant value. Individual directional data can be analysed if required.

With the datalogger selected it is possible to vary the sampling rate between 1.0 seconds and several hours. The memory capacity allows for a recording time of 1 day at a sampling rate of 60 seconds.

Provision was included for the instrument to be pole mounted in streets. For this application a single measuring point (three orthogonal coils) is attached to the pole 1 metre above the ground. Results are shown in Figures 3 and 4 where the instrument has been used in street locations for up to 5 days. The cyclic variation of the results is indicative of supply to a domestic area.

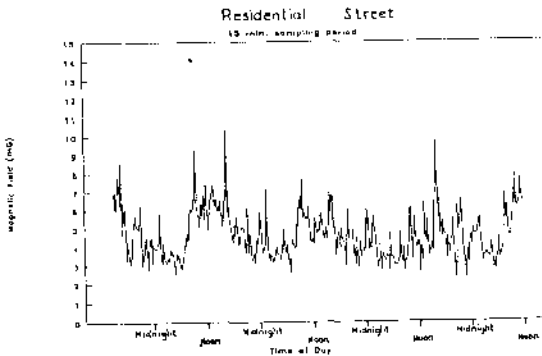

Figure 3 variation of magnetic fields over several days

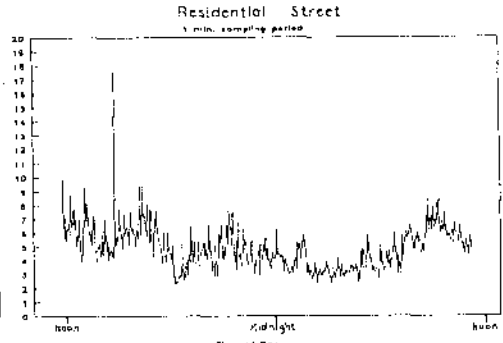

Figure 4 variation of magnetic fields over one day

The rapid variation of the field level combined with the daily cyclic variation could have ramifications for studies relying on spot measurements to quantify exposure. The time of measurement may introduce significant misclassification errors both from the point of view of short term variation and daily cyclic loading.

MEASUREMENT PROTOCOLS

For the measurement of residential data the measuring units will be located in the main living area, the main bedroom and the near the front door. Simultaneously measurements are also taken of the active, neutral and earth return currents.

A calibrating load will be operated for short periods at a range of locations throughout the house to measure the sensitivity of the household measuring locations to household power consumption. This load draws 10 amp and will cycle on and off each 10 seconds. The cyclic pattern will be visible in the recorded results and will give a measure of the contribution of the power consumption to the the overall magnetic fields.

Data is collected using sampling rates of 2 seconds during use of the calibrating load, 1 minute and 10 minutes. The short sampling time will collect details of the peaks and allow evaluation of the contribution provided by the house wiring. The 1 minute time will show the variation over a day and the longer sampling rate will show the cyclic pattern over several days including a weekend.

Household data regarding the electrical energy usage is recorded and use and type of electrical appliances for the measurement period is logged by the resident for factoring into the analysis of the data.

Details of street lines are noted for each location to test surrogates of magnetic field levels. This data includes the electrical proximity to the supply transformer as measured by the number of houses served by the transformer beyond the house selected for measurement. Other factors included with this data are the distance of the house to the lines and the function of the distribution feeder at that point, if present.

CONCLUSION

From the spot measurement survey it was determined that the sources that contribute to the residential magnetic field levels include the local distribution circuits, both low voltage and distribution voltage, the use of electrical energy in the home and contributions from the earth return currents. The relative importance of these sources depends on their relative strengths at the measuring point. To investigate the importance of components datalogging instrumentation has been developed and used with measurement protocols to try to evaluate the relative strength of each source.

The magnetic fields being measured in this survey and the assessment of the residents exposure relate to the long term pattern of the fields. The assessment of peak exposures must relate to appliances, their usage pattern and the strength of the associated magnetic field.

REFERENCES

"Magnetic Field effects in the Victorian Transmission System - Design and Measurement" A T Wilson, P J Wallace, D C Smith CIGRE 1990

"Measurements of ELF Magnetic Field Levels in Occupational and Domestic Situations" R J Owen ARPS Adelaide 1990

MAGNETIC FIELD EXPOSURE ASSESSMENT BY WIRE CODING

Vincent Delpizzo
Australian Radiation Laboratory
Yallambie, Victoria, Australia

Joanna L Borghesi
Department of Community Medicine
University of Melbourne, Melbourne, Australia

ABSTRACT

We describe the development of a wire coding protocol based on a study of electrical installations in Melbourne. Because of very significant differences between our power distribution system and that used in Denver, a different approach from that used by Wertheimer and Leeper was required.

INTRODUCTION

The hypothesis that exposure to extremely low frequency (ELF) magnetic fields may be responsible for an increase in the incidence of cancer remains the subject of several epidemiological studies. Wire coding, that is the grouping of residences based on the type, number and distance of nearby visible electrical installations, has been repeatedly used for assessment of exposure¹⁻⁵. In some studies³⁻⁵ actual measurements of the magnetic fields were also carried out, but, where an association with cancer was found^{3,5}, it was stronger for classification based on wire coding than for that based on measured fields. This can be interpreted in two ways: i) wire coding is a better index of magnetic field exposure than measured magnetic fields, either because it is less affected by time variability or because it is correlated to a parameter of the magnetic field different from the one measured (usually the time weighted average) or ii) wire coding is also correlated to some unidentified confounder which is responsible for the association with cancer.

In either case, it is important that analysis of data classified by wire coding remain a part of current residential exposure studies, so that either the relevant magnetic field parameter or the confounding agent can be identified.

Wire coding was devised specifically for the Wertheimer and Leeper studies in Denver and Boulder, Colorado. Electric power distribution practices vary significantly from place to place and it can not be assumed that the Denver code may be used in a different locale.

We describe here a wire coding protocol that we have developed for Melbourne, Australia, as part of the preliminary work for an epidemiological study of residential exposure to ELF magnetic fields and childhood cancer.

METHOD

The main difficulty we encountered was due to the fact that, in Australia, pole mounted transformers have a typical power rating much larger than that common in the US. A single transformer may supply a secondary distribution line consisting of dozens of spans. The current drop along the secondary line is thus very gradual and the resulting variation in the strength of the magnetic field from point to point of the same line is less than random time variability. Moreover, the lines often branch into side streets and it is very difficult for a field worker to classify a house in relation to its distance from the transformer. The use of standard gauge wire contributes to make classification difficult.

Our objective is that of identifying two reasonably large groups of subjects that can be reliably regarded as 'high' and 'low' exposure and an intermediate category which will contain most of the subjects whose exposure is less easily determined. We anticipate that this approach will not allow a reliable estimate of a risk-exposure trend (because of the large misclassification of the intermediate group). However, it offers the advantage over simple dichotomous classification of comparing two smaller but reliably classified groups, rather than two groups both grossly affected by misclassification.

Using a random number generator, we identified 415 points in the Melbourne metropolitan area. At each of these points, measurements were taken directly under the power lines, if any existed or at an equivalent position on the sidewalk, if no electrical installations were visible.

RESULTS

The data obtained from the random measurements are summarized in Table 1. According to these data, in a sizable fraction of the metropolitan area there are no significant external sources of ELF magnetic fields. Thus, it should be possible to identify with a certain degree of confidence a sufficiently large reference group.

The approximate magnetic field profiles were calculated from the median values of the measured magnetic field. These are plotted in Figure 1 for the most important wire types, as a function of the horizontal distance in the direction perpendicular to the line.

Note that in several cases this profile is asymmetrical, due to the presence of an unbalanced current. This introduces an additional uncertainty, since in general we cannot determine the predominant direction of the unbalanced current. Thus at a distance of 10 m from a secondary line the field may be less than 20% or more than 40% of the field measured under the line.

Table 1
Summary of magnetic field measurements

Wire type	Number of occurrences	Magnetic field (μT) mean	Magnetic field (μT) median	Stand. dev.	Quartile lower	Quartile upper
1	71 (17.1%)	0.067	0.017	0.146	0.017	0.042
2	18 (4.3%)	0.077	0.029	0.105	0.017	0.095
3	48 (11.6%)	0.078	0.017	0.149	0.017	0.032
4	20 (4.8%)	0.350	0.276	0.330	0.074	0.517
5	73 (17.6%)	0.359	0.279	0.306	0.121	0.489
6	74 (17.8%)	0.439	0.312	0.371	0.152	0.669
7	9 (2.2%)	0.530	0.461	0.356	0.288	0.695

(Wire type code: 1 = no visible wires; 2 = end pole; 3 = primary; 4 = 2 phase secondary; 5 = secondary; 6 = primary + secondary; 7 = high voltage distribution line + primary + secondary).

The 'strength' of a power line as a source of residential magnetic fields was defined as a function of the wire type and distance from the house. We arbitrarily defined a strong source as a power line capable of generating a typical field of 0.16 μT or more at the point of a house closest to the line.

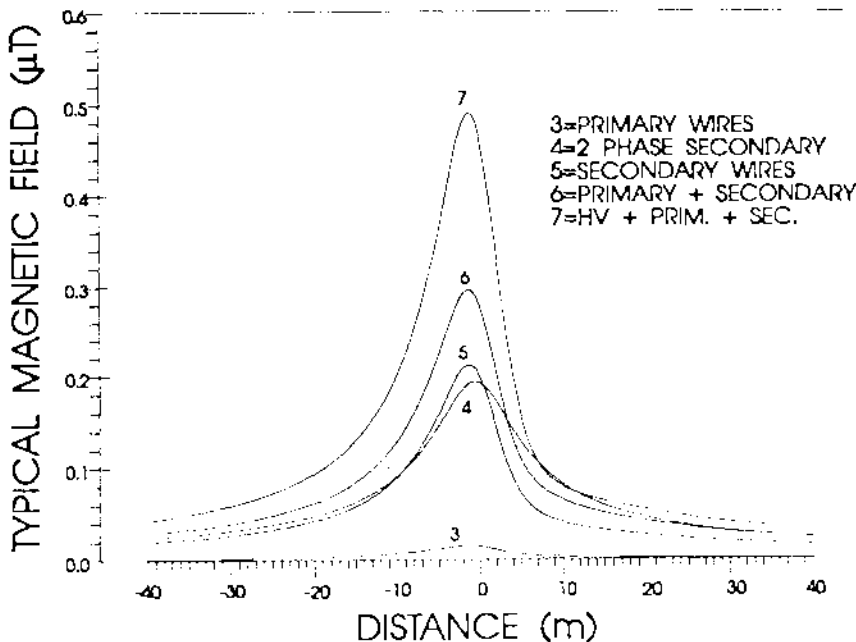

Figure 1. Typical magnetic field profile for several wire types.

Table 2
Exposure scores assigned to several wire types on the basis of their distance from a residence.

Wire type	Strong source (score = 4)	Moderate source (score = 2)	Weak source (score =1)
4	0 - 7.0 m	7.5 - 18 m	18.5 - 28 m
5	0 - 6.5 m	7.0 - 14 m	15.5 - 35 m
6 or 7	0 - 10.0 m	10.5 - 20 m	21.5 - 40 m

A line generating at that point a typical field of 0.08 to 0.16 μ T is regarded as moderate and one generating a typical field of 0.04 to 0.08 μ T is considered weak. From Table 1 and Figure 1 we determined, for each line type, the distances from the lines at which a median field of approximately 0.16, 0.08 and 0.04 μ T could be expected. Exposure scores were assigned to reflect the relative strength of the various sources (Table 2). Less common wire types were also similarly classified.

Houses with nearby sources totalling a score of 4 or more are classified as high exposure, while houses affected by no more than one weak source are regarded as low exposure. Houses with a total score of 2 or 3 are classified as medium exposure.

Validation of this exposure assessment protocol is, strictly speaking, not possible, since we do not know what the 'true' exposure metric is. We are investigating the long term correlation between this and other possible exposure indices.

REFERENCES

1. Wertheimer, N. and Leeper, E., 1979, Electrical wiring configurations and childhood cancer, *Am. J. Epidemiol.*, 109, 272-284.
2. Wertheimer, N. and Leeper, E., 1982, Adult cancer related to electrical wires near the home, *Int. J. Epidemiol.* 11, 345-355.
3. Savitz, D.A., Wachtel H., Barnes, F.A., John, E.M. and Tvrdik, J.G., 1988, Case-control study of childhood cancer and exposure to 60 Hz magnetic fields, *Am. J. Epidemiol.*, 128, 21-38.
4. Severson, R.K., Stevens, R.G., Kaune, W.T., Thomas, D.B., Heuser, L., Davis, S., Sever, L.E., 1988, Acute non-lymphocytic leukemia and residential exposure to power frequency electromagnetic fields, *Am J Epidemiol* 128, 10-20.
5. London, S.J., Thomas, D.C., Bowman, J.D., Sobel, E., Peters, J.M., 1991, Exposure to residential electric and magnetic fields and risk of childhood leukemia, *Am. J. Epidemiol.* 134, 923-937.

L'ORGANISATION DES POUVOIRS PUBLICS ET DES SECOURS EN FRANCE
EN CAS D'ACCIDENT NUCLEAIRE

M. le Préfet C. GUIZARD,
Secrétaire Général du Comité Interministériel de la Sécurité Nucléaire

THE FRENCH GOVERNMENTAL ORGANISATION AND RELIEF IN FRANCE
PLANNING IN CASE OF A NUCLEAR ACCIDENT

Despite of the unlikeliness of a nuclear accident, emergency planning is a must. It has several aspects : Internal Emergency Plan, Specific Intervention Plan, Post Accident and Relief specialized Plan. As a whole, the organisation is similar to the one used for others industrial risks. In a "Department", the supervisor for overall emergency action is the "Prefet", a high civil servant appointed by the Cabinet and responsible for nuclear security ; all the other civil servants are under the Prefet's command and assist him. A national post-accident plan is being worked out ; it will cover all the fields of intervention: control, administration of stable iodine, sheltering or evacuation.

----*--*

Les 55 réacteurs nucléaires Français et toutes les installations nucléaires associées, en particulier celles du cycle du combustible, obligent les pouvoirs publics à être en mesure de protéger les personnes qui pourraient être affectées par un accident sur ces installations. En effet, même si l'exploitant fait la preuve qu'il est toujours capable de ramener son installation dans un état sûr, quoi qu'il arrive, l'autorité politique ne peut pas faire aujourd'hui l'économie de la préparation des mesures qui permettraient de faire face à un accident dans le but d'en réduire le plus possible les conséquences. Tant que la technique ne permet pas d'affirmer que la probabilité d'un accident grave est réellement nulle, les responsables gouvernementaux mettent donc en place des plans d'urgence ;

- plan d'urgence interne (PUI) pour le personnel des installations,
- plan particulier d'intervention (PPI) pour le public applicable dans les premières heures qui suivent l'accident,
- plan post-accidentel (PPA) qui intervient après le PPI lorsque l'accident a des conséquences de longue durée,
- plans de secours spécialisés tel par exemple ceux associés aux transports de déchets radioactifs.

Il est clair que la pérennité du choix nucléaire, alternative énergétique la plus économique lorsque les autres ressources énergétiques nationales sont réduites, est liée à cette capacité d'annihiler toute velléité d'accident ou dans le pire des cas à en supprimer toute conséquence. Le monde ne pourrait pas supporter un second Tchernobyl ; ceci étant, 5 ans après, les réflexions de nos collègues soviétiques sont pour nous très précieuses et nous les remercions de nous en faire part.

L'organisation en cas d'urgence nucléaire ne diffère qu'assez peu de celle adoptée pour d'autres risques industriels ou naturels. La décentralisation de 1982 ne concerne ni la police, ni l'armée dont fait partie la gendarmerie et l'un des points forts du système français vient encore de cette centralisation napoléonienne.

Les Préfets nommés par le gouvernement sont les premiers responsables sur leur département des mesures à prendre pour le public : protection des personnes, information, police, contrôle sanitaire, soins, évacuation, etc... Le plan ORSEC (organisation des secours) départemental recense les moyens à mettre en oeuvre et leurs conditions d'emploi pour toutes les catastrophes. Le passage du PUI au PPI a pour conséquence que le Préfet gère l'ensemble des moyens disponibles, y compris ceux qui avaient fait l'objet de conventions particulières au titre du PUI. Il use en tant que de besoin de son droit de réquisition.

Le Préfet prend l'avis des autorités centrales de l'état (Service de Protection contre les Rayonnements Ionisants - SCPRI, Direction de la Sûreté des Installations Nucléaires), qui délèguent sur place leurs représentants comme conseillers directs du Préfet, qui examinent la situation depuis les centres de Crise de Paris, qui renforcent en personnels et en moyens les équipes préfectorales (pompiers, équipes médicales, hélicoptères,...), qui donnent éventuellement des directives au Préfet. Le Secrétariat Général du CISN ⁽¹⁾ que je dirige, placé auprès du Premier Ministre, suit la situation depuis le centre de Crise de l'Hôtel Matignon, informe le Premier Ministre et décide si nécessaire d'informer les autorités étrangères et internationales vis à vis desquelles nous sommes le point de contact. Dans le cas où l'accident prend une ampleur géographique qui dépasse le département, un préfet coordonnateur est désigné pour assurer la cohérence des actions prises dans les autres départements.

Au niveau local les postes de commandement sont opérationnels dans l'heure qui suit l'alerte. Ce sont environ 40 ingénieurs et techniciens qui sont mobilisés. L'organisation nationale est opérationnelle en 1 à 2 heures avec mobilisation d'une vingtaine de spécialistes.

Ces temps sont tout à fait compatibles avec les scénarios d'accidents envisagés dans nos réacteurs à Eau pressurisée : la présence de l'enclume de confinement, la durée de sa montée en pression pour atteindre celle à laquelle il serait nécessaire de l'ouvrir sur l'extérieur par les filtres à sable font qu'un rejet à l'extérieur n'est pas envisageable avant un délai de plusieurs heures après le début de l'accident.

(1) CISN = comité interministériel de la sécurité nucléaire

Le contrôle de l'efficacité de ce système est assuré par chacun des niveaux d'action et de nombreux exercices sont effectués régulièrement dans les installations, dans les Préfectures au niveau local, au niveau national par la Direction de la Sûreté Nucléaire ou par le Secrétariat Général qui décide une fois tous les 2 ou 3 ans d'un exercice national avec tous les acteurs du temps de crise. Le dernier exercice a mis en évidence les difficultés de l'information du public et des élus locaux en temps de crise ; aussi, des formations adéquates vont être mises en place pour tous ceux qui seraient requis. Le fonctionnement des Etats-Majors nationaux est apparu satisfaisant tandis que les Etats-Majors locaux doivent encore s'entraîner à faire face à ces situations.

Une ébauche de plan post-accidentel type a été réalisée. Elle doit être revue et améliorée, notamment au niveau des moyens pour recevoir des cartes en couleur, pour mesurer l'activité présente dans l'environnement et pour rendre performantes les transmissions. Ce sont d'abord les Cellules Mobiles d'Intervention Radiologiques (CMIR) des pompiers qui interviennent pour effectuer ces mesures sur le terrain.

Si besoin est, les moyens du CEA sont ensuite mis en oeuvre; cela peut aller jusqu'à la réquisition de tout le personnel et de tous les moyens de laboratoire disponibles ; des mesures par hélicoptère aident à dresser rapidement une carte de la contamination existante et les moyens de calculs de l'Institut de Protection et de Sûreté Nucléaire, appui technique des décideurs, permettent d'effectuer des prévisions sur l'évolution de la situation. Les moyens du SCPRI sont aussi d'un grand secours dans ce cas, tant pour les mesures sur le terrain que pour le contrôle des populations. Ce sont une voiture rail spectrométrique, 2 semi-remorques, 18 Master-Géminis ; des engins télécommandés permettent d'intervenir en milieu contaminé : un télémanipulateur, un engin téléopéré (VERI), un robot pour l'intérieur des bâtiments (CENTAURE), des mini-engins OSCAR, des engins de génie civil.

La philosophie Française est celle des recommandations de la CIPR, et des règles de la CEE. Cependant compte tenu des risques liés à des évacuations trop vite décidées, ainsi que du caractère d'irréversibilité des conséquences de ces évacuations, la France, comme la Grande-Bretagne recherche plutôt le confinement que l'évacuation. Rappelons que le choix des sites est toujours effectué pour que le nombre de personnes à évacuer ne soit pas trop important ; par exemple, certaines communes qui passent de 2000 habitants à 20 000 ou 30 000 en période estivale ont été éliminées pour cause d'évacuation trop difficile.

La distribution d'iode stable peut être demandée par le SCPRI; cette administration destinée à suture la thyroïde est justifiée lorsque l'activité de l'air respiré atteint 800 Bq/m^3 avec une durée prévisible d'exposition ne dépassant pas 10 jours; dans le cas d'une durée plus courte, le niveau à prendre en compte pourrait être plus élevé (8000 Bq/m^3 pour moins de 24 h par exemple).

Des stocks de comprimés d'iode (50 mg sous forme d'iodure de potassium) ont été constitués au niveau national (SCPRI, Service Central de santé des Armées, Hopitaux centraux) et au niveau local (Centrales nucléaires, Hopitaux Régionaux notamment). Leur distribution préventive continue de faire l'objet de réflexions sur le meilleur moyen de la réaliser : pompiers, gendarmerie, associations, enseignants. Une notice explicative serait distribuée simultanément. Les enfants et les femmes enceintes qui présentent une plus grande sensibilité, seront servis en priorité ; ils constituent d'ailleurs aussi le premier groupe de population auquel on interdirait la consommation de lait frais (activité supérieure à 500 Bq/Kg et à 150 Bq/Kg pour les nourissons). Les normes imposées par la CEE, sont des normes de commercialisation pour l'exportation et pourraient être dépassées dès lors qu'il s'agirait de la survie des populations.

Une surveillance permanente du territoire est assurée par : le réseau Téléray du SCPRI : les 67 stations transmettent automatiquement leurs mesures dans les préfectures, au SCPRI et à tous ceux qui en font la demande ; ces mesures, disponibles en permanence sur le minitel, sont consultables par toute la population ; une interrogation s'effectue automatiquement toutes les heures. Une station vient d'être installée au sommet de l'aiguille du Midi (3840 m) dans les Alpes et d'autres seront encore installées. De plus, un important réseau de prélèvement sur les avions longs courriers permet de prévoir l'arrivée de nuages radioactifs ; cela avait permis au SCPRI de communiquer à l'AFP, 60 heures après l'accident de Tchernobyl, la composition exacte du nuage en provenance d'URSS.

Le SCPRI peut accueillir jusqu'à 25 personnes exposées au rayonnement ou contaminées et est en mesure, selon l'urgence, de répartir les accidentés dans les hopitaux spécialisés. Au niveau régional, le SCPRI dispose de 4 divisions (Bordeaux, Avignon, Angers, Nancy) qui assureraient l'intervention immédiate sur place. Localement, une attention toute particulière est apportée à la gestion prévisionnelle des soins aux irradiés, afin d'être certain qu'il n'y aura aucune difficulté.

La dizaine d'exercices qui sont déjà réalisés chaque année oblige tous les acteurs à réfléchir sur le rôle qu'ils auraient à jouer en cas d'accident et conduit à perfectionner constamment ce système, de telle sorte que les aléas certains d'une situation de crise soient aussi limités que possible. Des détails sur toutes ces mesures vont vous être présentés et vous pourrez convenir que la France apparaît aujourd'hui tout à fait à même de gérer une situation d'accident nucléaire au mieux des intérêts du public.

EMERGENCY PLANNING AND EXERCISING
WITHIN BRITISH NUCLEAR FUELS plc

N J W McPhail, N J Oakes,
BNFL, Health and Safety Directorate,
Risley, Warrington, Cheshire, England

Abstract

Emergency planning within BNFL covers arrangements to deal with the on and off-site effects of an incident. The on-site arrangements cover measures to recover the situation at the scene of the incident and protection of the workforce. The off-site arrangements include co-ordination of the off-site emergency response, implementation of counter-measures to protect the public and information flow to the public, media and government. Regular emergency exercises held to test the arrangements may involve some 12 agencies and many hundreds of persons over a 2-day period.

Introduction

The general principles of emergency arrangements are common to all British Nuclear Fuels Plc (BNFL) sites. Detailed local arrangements at each site reflect their specific hazard, their local management arrangements, and the arrangements for emergency response within their county. As an illustration the arrangements described within this paper are those specific to BNFL's Sellafield site, the UK's centre for the reprocessing of irradiated fuel and also the site of the world's first large-scale nuclear power station, Calder Hall.

Background

The possibility of an accident leading to the release of sufficient radioactive material to cause interference with the normal activities of the public or requiring special arrangements to be made to protect the workforce is remote. During design of plant, safety aspects are considered to be of great importance and all credible combinations of events which could lead to an accident are taken into account. The Site Licence, issued by the Health and Safety Executive (HSE), also requires BNFL to make arrangements for dealing with any accident or other emergency on the licensed site which affects, or might affect, the safety of any person or property whether on or off the site. The emergency arrangements for Sellafield are essentially split into two broad interrelated sections, the arrangements for within the site, and the arrangements for off the site.

On Site Emergency Organisation

The principal aims of BNFL's site emergency management organisation are as follows:

- i recover the situation at the scene of the incident
- ii establish lines of communication to the incident plant, the remainder of the site and off-site
- iii alert people in the affected areas of the site, and handle any resultant local site evacuation and radiological monitoring
- iv keep people on site out of the affected areas by closing roads where necessary and providing adequate diversions
- v inform the site generally of the problem, including repre-

representatives of Staff Side and Trade Unions, and
vi notify external organisations where appropriate.

The emergency management functions outlined above would be discharged from a number of emergency centres established on declaration of a Site Emergency Standby. The principal centre, the Site Emergency Control Room (SECR) would act as the focus for the co-ordination of all post-accident management control functions. It would be manned on a continuous basis by designated senior staff until cessation of the emergency.

To provide a focus for the co-ordination and organisation of rescue and recovery operations on the incident plant, an Incident Control Centre (ICC) would be established. It would be located within or as near the affected plant as conditions permit. To control access to and from the incident area an Access Control Point (ACP) would be established. At this single point of entry to the incident location all necessary radiological advice and protection would be provided to personnel involved in rescue and recovery operations. A Health Physics (HP) Monitoring Station would be set up adjacent to the scene of the incident as a centre for the measurement of all HP samples obtained from the vicinity of the incident plant.

The focus for collection, collation and interpretation of HP data and for the management of HP resources would be the Health Physics Information Room (HPIR). Radiological data received from the scene of the incident, other areas on site, and from the district monitoring teams would be processed as appropriate. Additionally a continuous direct read out from a system of remote monitoring stations located at the site perimeter is also available in this room. This information would be passed to other centres such as the SECR and District Control Centre, (See below), for action as appropriate.

Other centres designated to receive and treat personnel affected by the emergency eg emergency reception centres, medical centres and decontamination centres would be activated depending on the severity of the incident. Control and communication with personnel on the remainder of the site would be achieved from the SECR via a communication network of manned Area and Building Control Points.

Off-Site Emergency Arrangements

Responsibilities for actions offsite to protect the general public rests with local and national organisations eg emergency services, health and environmental protection agencies according to their statutory responsibilities as for other types of emergencies. Each organisation has its own detailed arrangements and an overall composite plan is prepared. To ensure a coordinated response can be provided and the general public are appropriately advised, BNFL would establish a District Control Centre (DCC) and Media Briefing Centre (MBC) in a Company hostel some 13 Km from the site. The function of the DCC is to:

- i ensure the activities of the participating organisations in the District Emergency Scheme are effectively coordinated.
- ii provide a centre where definitive advice on the course of the

incident and the effect on the public and the environment can be given.

- iii provide a focus for information on the course of the incident for the media (via the MBC), and the general public (via the Public Information Centres).

The DCC would be staffed by representatives of all agencies with a responsibility in the emergency. The organisation of the centres although a matter for local and national agreement, is generally organised around a conference facility permitting close liaison between representatives of all organisations, together with adjacent facilities for each organisation.

In order to operate successfully, the key function of the DCC is to offer definitive advice on the course of the incident and the offsite consequences of the incident in terms of potential or actual radiation exposure. Emergency environmental monitoring resources are deployed and controlled from the site. The results of the surveys would be interpreted and fed to the DCC, where, initially, a BNFL team of Health Physicists would be available to advise the agencies on the actions which should be taken to protect the general public, ie sheltering, evacuation or the issue of iodate tablets. For any incident involving offsite action to protect the public, a government representative would be appointed by the Secretary of State for Energy to report to the scene as quickly as possible and to take over responsibility from BNFL for advising the police and local authorities on actions necessary to protect the public.

A Media Briefing Centre is provided with appropriate facilities for representatives of the media. This centre would be manned continuously by BNFL and Constabulary staff, supplemented, as necessary, by representatives of other organisations manning the DCC. Media briefings would be held at regular intervals.

In the event of evacuation of the general public being required, reception centres would be established at an appropriate location dependent on the prevailing weather conditions and following consultation with representatives of the voluntary services and appropriate county and district council officers. Public Information Centres would be established in County libraries to provide information and advice to residents within the district, whose fears may have been unnecessarily aroused. All 24 hour manned Police Stations would be activated to deal with enquiries from the public about the incident.

In addition to the above local centres, national emergency centres would be established as well as the control centres of the individual organisations.

Exercising the Plans

In order to test the effectiveness of the emergency procedures and to develop the necessary skills of staff involved in post-accident management, regular emergency exercises are held. The scale of these exercises ranges from building emergency exercises related to specific plants to full scale Site and District Emergency exercises. The frequency of these exercises are determined by Site

Licence Provisions and exercises are independently assessed by HMNII inspectors. In addition to exercises, regular training is given to all levels of staff involved in emergency duties.

Procedure for planning District Emergency exercises within BNFL

The planning of District Emergency exercises which can involve some 12 agencies and several hundreds of persons over a 2 day period, follows a now well established procedure at BNFL Sellafield.

- i Planning usually commences some six or more months in advance of the proposed date of the exercise.
- ii The representatives of all organisations involved in planning and taking part in the exercise are invited by the Company to form an exercise steering group of some 20 individuals chaired by a senior representative of BNFL. The group approves the overall objectives of the exercise, including the outline technical scenario and selects a working group of representatives to undertake detailed planning.
- iii The working group and it's sub-groups progress the detailed planning of the exercise, including technical scenario derivation, driving inputs, media simulation.
- iv Documentation describing the full exercise arrangements is ultimately referred back to the steering group for endorsement at a meeting usually held 1 month before the exercise. Key documentation is used as briefing material for exercise participants.
- v The exercise is conducted according to the agreed arrangements determined during planning. The exercise is independently assessed by a team lead by the Nuclear Installations Inspectorate (NII).
- vi Within 24 hours of the end of the exercise a 'hot' debriefing meeting is held for the principal participants and assessors, chaired by the Chief Assessor. A note of this meeting is prepared and circulated to agencies promptly to enable them to submit their detailed comments in writing, within 4 weeks of the exercise.
- vii A draft follow up report is produced by BNFL and circulated to the steering group for approval within 2 months of the exercise.
- viii The detailed follow-up of exercises is vested in a small working group of representatives of key agencies who report back to the steering group at appropriate intervals, nominally 6 months.

Conclusion

The safety precautions taken in the design and construction of a nuclear installation and the safety standards used in operating them, reduce the chance of accidents to an extremely low level. Emergency planning provides an additional assurance that even if an accidental release of radioactive material were to occur, arrangements exist for prompt action to protect both the workforce and the general public. Major exercises are held regularly to test these arrangements and train staff involved in implementing them. Experience gained leads to constant evolution and improvement in the plans.

A TABLE TOP EXERCISE AND WORKSHOP

J. R. A. Lakey

John Lakey Associates, Meopham, Gravesend, UK

ABSTRACT

Table top exercises are widely applied in training for emergency preparedness and have long been a feature of Courses on Planning for Nuclear Emergencies. Experience of a large number of table top exercises is used to provide a classification of the types of exercise indicating the application and the disadvantages. The use of workshops is considered to be complementary rather than an alternative to teaching methods available from table top exercises.

INTRODUCTION

The types of table top exercise which may be used to achieve emergency preparedness are reviewed on the basis of experience in running training and facility exercises (1). The method of conducting the exercise is also evaluated and where appropriate the disadvantages of the approach are given. In some cases a workshop may be more effective since the emergency planning problem can be approached by synthesis from existing components or an existing plan may be analyzed.

TYPES OF EXERCISE.

Linear. The scenario does not deviate from a predetermined sequence of events and the participants follow a route for which correct solutions have been specified. Unexperienced staff or students can perform directing staff duties. The exercises which have been applied in the Planning for Nuclear Emergencies courses at Harvard (2) since 1981 and at the Surrey University courses since 1987 are linear and are designed to stress the approach recommended by NRC (3). The exercise is developed based on a real incident and is run in real time (4). The method can be transferred internationally with few language difficulties.
Disadvantage: Lack of opportunity for initiative by the participants and not acceptable to those who have some experience in the field.

Open Play. The exercise is free running from the point of the initial scenario and the out-come is not known. It is preferred by students but demands considerable directing staff time. This method has been used in table top exercises at the RNC (5, 6) since 1976 and is useful for developing communication procedures between on-site and off-site facilities. A bank of messages, media questions and the injection of additional scenario items is required to keep up the momentum.
Disadvantage: The evaluation of success is difficult and the play may fail to cover some key areas.

Experimental. The exercise may be performed as an experiment to study a dubious feature of the plan and this may be approached from several different points of view by repetition of the exercise. An exercise of this type has been conducted by FEMA (7) to study post accident relocation decisions by using ten "mini-scenarios" each focused on one problem. The play was conducted in a "no fault" mode so that the participants concentrated on the identification of issues, problems and procedures arising during this post accident phase.

Disadvantage: Expensive in staff time and the number of scenarios which can be examined is limited.

CONDUCT OF THE EXERCISE

Rôle Playing. All of the above exercises may use rôle playing and it is an advantage if some individuals perform their normal task in the scheme. This is stimulating and can be used to enable a new member of a team to play themselves into their team position.

Disadvantage: The course of the exercise cannot be predicted and so it is difficult to ensure that a particular topic has been covered.

Functional Play. Functional play involving the players as groups or teams with a specific task. Typical tasks are, assessment of the event, media contact, rumour control and in this way exercise may focus on the desired topics. It is an advantage when functions are played by the group responsible for that aspect of the plan.

Disadvantage: Individuals may opt out of the play.

Committee Exercise. When broad issues are on the agenda and a large numbers of players must participate the exercise can be conducted like a committee meeting at which regulatory authorities, service organisations etc. are represented. The NRC conducted such an exercise (8) which ran for two days with 90 players. The first day was used to define rôles and review the accident through the plume phase. On the second day the play turned to re-entry, relocation and then to decontamination and recovery. The NRC found it to be difficult to adequately discuss all the issues attempted in the exercise but 12 important lessons were identified. A committee exercise encourages an exchange of views and a good chairman can ensure useful conclusions. The method can be entertaining and has been used in the UK as the format for a television documentary.

Disadvantage: Limited scenario with the temptation to seek too many aims especially with a large number of players.

Communication Exercise. In many exercises communications is the only part of the emergency scheme to be tested and the table top is ideal for this purpose. In some case a field exercise may be enhanced by using a table top team to provide communication responders. This avoids the use of dedicated networks and reduces the chance that exercise messages may be received outside the area of play. Communications are the weakest link in any scheme and

frequent table top testing is strongly recommended. Disadvantage: It is unrealistic to run communications exercises in the absence of the uncertainty and errors associated with a real event.

WORKSHOPS.

The exercises described above are run under pressure which can be avoided by using a workshop format to analyze or synthesize the plan.

Analysis. Participants analyze selected parts of the scheme critically reporting to a plenary session on their findings.

Synthesis. The teams are free to create a plan from elements provided by the directing staff but they have to defend their choice of plan in plenary session.

SURREY UNIVERSITY TABLE TOP EXERCISE AND WORKSHOP

Table Top Exercise.

The aim is to give participants an overview of planning and preparedness concentrating on the communications and management problems which arise in the first few hours of an incident. The technical aspects of the initiating conditions are considered and an assessment of dose due to the release of fission products is made. The players are assigned to one of four functions:-

Technical - plant conditions, assessment, recovery,

Radiation Protection - dose assessment, access, re-entry, protective action,

Communications - local authority, media and preparations for a press conference,

Management - actions, assistance, security and records.

This is a linear exercise but some mistakes similar to those made in the real incident are inserted in the scenario. A press conference is held and video taped for critical review at the plenary session. The scale of the event is then raised to produce a significant release of fission products which are evaluated.

Workshop.

The aim of the workshop (9) is to prepare a plan for the exercise site based on a list of tasks and a model plan. The actions required by the plan are analyzed to identify the responsible team, the authority under which they are acting and the support required. The plan is reviewed to find out if it is sufficiently robust to cope with an overload of the communication systems, with excessive doses to off-site workers and with an extended emergency.

CONCLUSIONS.

The table top exercise is recommended as a powerful training tool which is most successful when all participants are actively engaged throughout the exercise. The least effective being the committee type of exercise. Table top exercises also provide support for field exercises and may be used for research and for evaluation of plans and preparedness for nuclear emergencies. Workshops provide a complementary training technique in which the plan may be examined in depth.

REFERENCES

- (1) Sedge, L.A. and Lakey, J.R.A., 1986.
Fire Training, Drills and Exercises in the Nuclear Industry,
The Nuclear Engineer, vol. 28, pp. 16 - 20.
- (2) Moeller, D.W. and Selby, J.M., 1976.
Planning for Nuclear Emergencies,
Nuclear Safety vol. 17, pp. 1 - 14.
- (3) Nuclear Regulatory Commission, 1980.
Criteria for the Preparation and Evaluation of
Radiological Emergency Plans and Preparedness in
Support of Nuclear Power Plant.
NUREG- 0654 / FEMA - REP - 1.
- (4) Lakey, J.R.A., Barratt, K.L. and Marchant, C.P., 1983.
Nuclear Reactor Emergency Exercises and Drills,
IAEA-SM-280, Rome.
- (5) Lakey, J.R.A., Junes, A.G. and Gibbs, D.C.C., 1986.
Training at the Royal Naval College for the Nuclear
Propulsion Programme, Seminar Proceedings of the
Institution of Mechanical Engineers, London.
- (6) Lakey, J.R.A., 1988.
Education and Training for Emergency Procedures,
Radiation Protection Practise, 7 th International
Congress of the International Radiation Protection
Association, vol. 3, pp. 125 - 152.
- (7) Gant, K.S., Adler, M.V. and Wolff, W.F., 1987.
Relocation Table Top Exercise - Federal Radiological
Response in the Post Accident Phase,
Nuclear Safety, vol. 28, pp. 86 - 89.
- (8) Zech, G. et al., 1990.
Post Emergency Table Top Exercise, Lessons Learned
Report, NUREG - 1441 / FEMA - REP - 16.
- (9) Lakey, J.R.A., 1990.
Workshop on the Management of Nuclear Emergencies,
Paper 12, Course on Planning for Nuclear Emergencies,
University of Surrey, Guildford.

COORDINATED PROTECTION OF THE POPULATION IN EMERGENCIES IN SWITZERLAND: THE NATIONAL EMERGENCY OPERATIONS CENTRE (NAZ) AND THE EMERGENCY ORGANISATION RADIOACTIVITY (EOR)

Hans H. BRUNNER

Secretary Fachverband für Strahlenschutz (FS)

c/o GSEDI/Nationale Alarmzentrale (NAZ), Postfach, CH-8044 Zurich, Switzerland

ABSTRACT

As a consequence of the nuclear weapons tests Switzerland has since 30 years expert commissions, concepts, monitoring networks, monitoring and emergency teams for the protection of the population following radiological accidents of all types inside or outside the country. Thus Chernobyl hit a prepared country - except information. The Radiological Emergency Organisation (EOR) and its National Emergency Operations Centre (NAZ) have up-to-date legal bases, concepts and operational means. Besides radiological events, NAZ deals also with chemical accidents, satellite crashes and dam breaks. Unique is the coordinated use of the combined means of civil authorities, civil defense and army in all strategic cases.

GENERAL ORGANIZATION, TASKS AND CONCEPTS

Nuclear tests caused Switzerland in 1964 to establish an emergency organisation for protection against any radiological incident inside or outside the country. Since 1979 the permanently operating contact point (Alarmstelle ARMA) and the National Emergency Operations Centre (NAZ, Nationale Alarmzentrale) are located in Zurich close to the Swiss Institute of Meteorology (SMA). In 1984 a fully protected underground installation was taken into use, the permanent team of the NAZ was enlarged (now 15 persons) and supplemented by a militarized staff.

The main purpose is to protect the population by early warning of authorities, timely alert and instruction of the population and initiation of protective and preventive actions.

The Radiological Emergency Organization (EOR) operated very successfully after the Chernobyl accident but was restructured to improve the cooperation at the government and political levels and the information of the public.

The head of the EOR is the Secretary General of the Federal Department of the Interior (GSEDI) who is supported by a Managing Committee (Leitender Ausschuss Radioaktivität LAR) consisting of the directors of the relevant federal authorities. This links the Emergency Organisation directly to the Government. The Information Centre of the Federal Chancellery is responsible for communications with the cantonal authorities and for information of the public. (Fig. 1)

The official concepts of Total Defense and of Coordinated Radiological and Chemical (AC) Protection provide for full cooperation of the resources of federal, cantonal and communal authorities and of emergency services, army and civil defense for preparations and actions. Cantons and communities dispose of most of the means for countermeasures and actions such as health services, food control, police, fire-brigades, civil defense or public transports and must assist EOR at the order of the Federal Government.

Legal bases for the organisation are the new radiation protection law, the revised radiation protection regulations (both fully adapted to ICRP-60) and regulations on the EOR and on the NAZ. EOR has the legal competence to request the cooperation of any public or private specialists or services needed in an emergency. The pre-Chernobyl action concept based on emergency reference levels has been replaced by a thoroughly revised dose-action concept (Table 1) which contains the general action criteria and upper and lower dose levels as action / non-action criteria both for immediate preventive actions and later countermeasures. This concept corresponding to international recommendations will be specified in detail for various types of events. Thanks to good shielding provided by massive houses and to the large number of shelters in Switzerland, the main preventive action is not horizontal but vertical evacuation, i.e. stay in the house -> basement -> shelter. Horizontal evacuation would only be a later, well planned action, if necessary.

A fundamental concept is to use normal means and structures as far as possible, and extraordinary ones only where necessary. Regrouping in the early phase of an event could only result in chaos. Governments, authorities, public services on all levels must have an emergency organisation allowing them at any time to cope with unusual events besides their normal operations. Special means needed for emergency purposes, such as computers and monitoring networks, are regularly used for normal purposes, too.

The Federal Commission for Radiological and Chemical Protection (KOMAC) with 25 members and an additional 70 scientists in its Working Groups supports the NAZ in the development of concepts, in the preparations and in the conduct of exercises.

NATIONAL EMERGENCY OPERATIONS CENTRE (NAZ)

The NAZ forms EOR's permanent nucleus and first-stage action team. A contact point operating 24 hrs/day (ARMA) at the meteorological computer center, a duty officer and automatic monitoring networks assure instant readiness, rapid warning and alarming of authorities, emergency teams and population, evaluation of monitoring data and quick initiation of protective and preventive actions. The main tasks of NAZ relate to radiological events, from transport or operational incidents over nuclear installation accidents to nuclear weapons events in peacetime and war, but also include satellite crashes, chemical incidents and dam breaks. Within a few hours the permanent team of the NAZ can be enlarged by a military staff (Armeeabteilung) of over a hundred scientists (mostly members of KOMAC working groups), specialists, and support personnel. Thanks to the militia system of the Swiss Army, they have been recruited among the best specialists and scientists in radiation protection, nuclear safety, chemistry, data processing, communications and other related fields. Their main tasks are the management of the monitoring and laboratory organisations, the collection and evaluation of all informations and data on the event and its consequences, the presentation of up-to-date informations on the situation, especially the radiological one, the evaluation and proposal of protective actions to be taken, the judgement of their effectiveness, and whatever consultative support may be required by the federal authorities and the Information Centre.

In action, the NAZ operates from an autonomous protected installation with modern data processing and communications systems and safe communications to national partners, neighbouring countries and IAEA.

The organisation in action is centred around the three overlapping sectors intelligence + information / monitoring / evaluation and consequences, which are supported by technical, computer and communications services.

MONITORING, DATA PROCESSING, COMMUNICATIONS

The monitoring organisation shall permit to detect, identify and verify radiological events and hazards, to forecast, follow and evaluate their development and extent, to estimate the doses to the population and to check the efficiency of countermeasures. It consists of automatic networks and of quickly activated monitoring posts, a laboratory organisation, and mobile monitoring and sampling teams with cars and helicopters.

The main monitoring networks is NADAM, an automatic radiation monitoring network coupled to the automatic meteorological monitoring network. It collects dose rate and weather data every ten minutes from 56 stations all over the country. Daily dose-rate averages from 16 stations are shown on text-TV together with basic informations on radiation and nuclear safety. Other automatic networks collect and measure aerosols (FWP/RADAIR) or monitor the environment of nuclear power plants (MADUK). 107 monitoring posts (AWP) at police stations, equipped with highly sensitive dose rate monitors, can be activated within 1-2 hours and transmit data at short intervals. Mobile monitoring teams comprise special teams of health physicists with all sorts of instruments and sampling devices, and teams of police, fire-brigade, army and civil defense radiation protection specialists, monitoring helicopters and an aeroradiometry helicopter. The core of the laboratory organisation for sampling and analysing all kinds of samples and especially food are 5 permanent special laboratories which also do routine radiological environmental monitoring. 20 cantonal chemistry laboratories have been equipped with radioanalytical instrumentation and can on short notice be supplemented by 30 total-defence radioanalytical laboratories with militarized staff in shielded underground locations. This suffices to collect and analyse the large number of daily samples required to control food quality all over the country, making use of established food control routines.

All the monitoring data (from routine monitoring and in emergencies) are transmitted to, stored and analysed in a large data processing system at NAZ (project PHOENIX) which is also the base for several applications and expert systems, for visual presentation of results and for the exchange of data and informations within the EOR and its partners.

Communications must be reliable and redundant in all situations and make use of all available technical means and public as well as special systems, including those of the army. Both for data processing and communications simple robust stand-by methods are available in case of failures of the main systems.

Monitoring is only part of the entire intelligence activities needed for verifying and evaluating an event, especially if it happens abroad. An extensive information network, with links to news agencies, military intelligence, private information networks such as NucNet, and close contacts to partner organisations in neighbouring

countries, institutions and scientists in other countries and to international organisations such as IAEA and ESA are indispensable for NAZ. IRPA and its associate societies, especially the Fachverband für Strahlenschutz, are of invaluable help in this task.

INFORMATION, PUBLIC RELATIONS

Information was the weak spot after Chernobyl, not on the scientific and specialist level but on the political and government one. As a consequence the Information Center (Infozen) of the Federal Chancellery was made fully responsible for this task and was accordingly reorganized and equipped. The facts will come from NAZ and EOR which will provide consultants to the Infozen.

But information of the public in an emergency is only credible and accepted, if NAZ and EOR are already familiar to the public and to local and regional authorities. This requires a well planned continuous public relations program which makes use of all publicity means and of all situations where the media and the public may be willing or interested to learn about emergency preparations. The Gulf war was such an occasion. The widespread radiophobia among media, politicians and public and their tendency to rather believe horror stories than facts do not simplify this difficult task.

In a multilingual country with three official languages, with 15% alien population and many tourists using several dozen languages the information is further complicated.

EXPERIENCES AND PROBLEMS

Chernobyl was not the first but the largest real operation of the EOR. Although no genuine emergency as far as exposure levels were concerned, it allowed a full scale run of the monitoring and laboratory organisation and data evaluation far beyond anything feasible in exercises. Political decision making and information were put to a severe test. Exercises of parts or the whole organisation are done every year. Their preparation, execution and evaluation puts a large additional load on the NAZ.

As everywhere in the nuclear and radiation protection field we also have an abnormal age-structure in our staffs and will have to replace more than half within the next 5-10 years. How to find sufficient new and well trained staff when radiophobia makes any nuclear or radiation job unattractive, is a yet unsolved problem as is the transfer of all the knowledge and experience accumulated by the first generation to the newcomers. How far artificial intelligence will be able to ease that problem remains to be seen; we are working on prototypes for decision support systems.

Although Chernobyl set free an unexpected amount of funds for emergency preparations, this effect may soon decay, so all new investments will need a thorough justification and optimisation.

European integration and cooperation will increase in the near future and our concepts as well as monitoring, data processing and communications systems must be or become internationally compatible.

REFERENCES

1. Brunner, H.: Protection of the Swiss Population Against Radiation Accidents" in "Strahlenschutz für Mensch und Umwelt" Aachen 1991, FS-91-55-T, p. 188, Series: Progress in Radiation Protection, TÜV Rheinland, Cologne Sept. 1991, ISSN 1013-4506.

Table 1: Dose-Action Concept

Protective action	Dose ¹	LDL ²	UDL ²
Stay indoors	$H_{eff,ext+Inh}$	1 mSv	10 mSv
Sheltering basement/shelter	$H_{eff,ext+Inh}$	10 mSv	100 mSv
Evacuation, if sheltering insufficient or no longer possible / acceptable	$H_{eff,ext+Inh}$	100 mSv	500 mSv
Other protective actions	$H_{eff,ext+Inh}$	1 mSv	500 mSv
Intake of stable iodine	$H_{Sch,Inh,Iod}$	30 mSv	300 mSv
Restrictions in food consumption	$H_{eff,Ing}$	1 mSv	20 mSv

1) Effective dose resp. thyroid dose from external exposure + inhalation resp. from ingestion during the first year after the event, without the protective action considered.

2) LDL = lower dose level, UDL = upper dose level (-> ICRP publ. 40)

Figure 1: Structure of the Emergency Organisation Radioactivity (EOR)

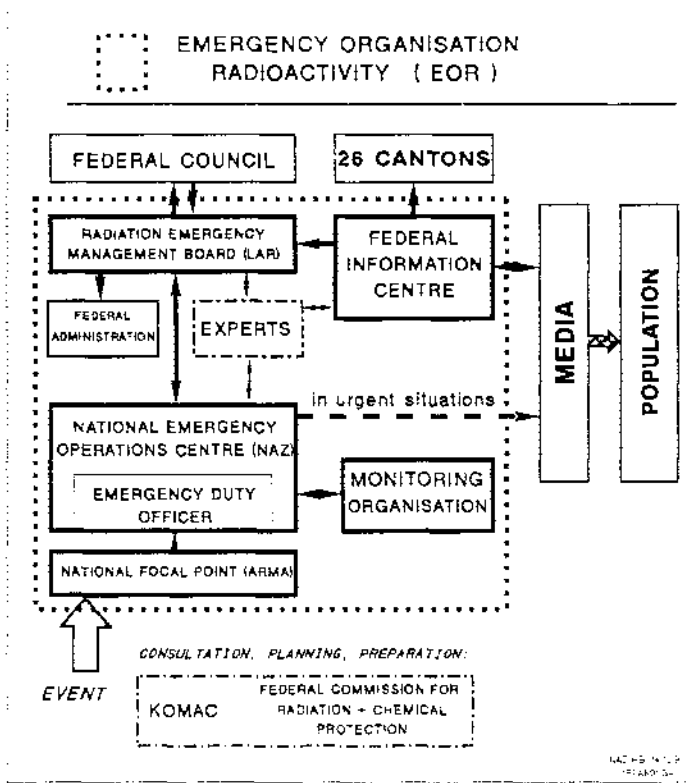
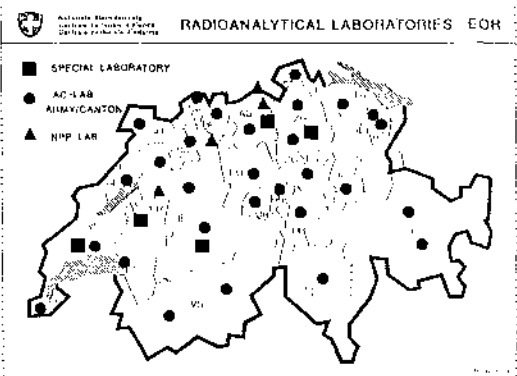
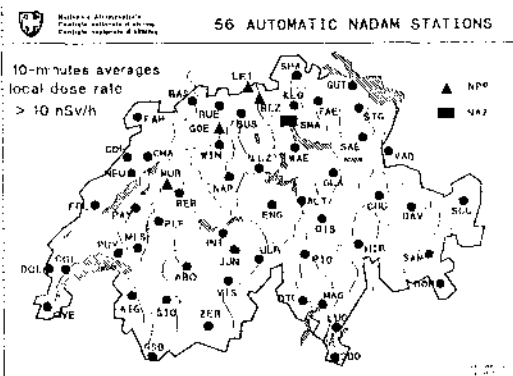

Figure 2: NADAM Automatic Monitoring Network

Figure 3: Radioanalytical Laboratories of EOR



THE NEW EMERGENCY ORGANIZATION IN FRENCH POWER PLANTS

B Houpin
Contrôleur général adjoint
Electricite de France

ABSTRACT

Initially, the emergency organization within french nuclear power plants was based on the practices used in conventional plants, extended to allow for the aggressions specific to nuclear activities. This approach tended to emphasize individual treatment needed, rather than taking due account of potential number of victims, which imposes a collective organization. After the Chernobyl accident a complete reorganization was undertaken with the exhaustive and rational approach used in nuclear safety, and based on the medical aid in catastrophes.

RESPONSABILITIES OF THE OPERATOR AND PUBLIC AUTHORITIES

French legislation aims to place responsibility on authority in best position to take action in a given area and at a given time. In general terms, the deciding factors are whether the activities are inside or outside the site and whether contamination has occurred or not.

As far as the preparation of emergency organization is concerned, the nuclear operator, who knows the risks involved, is consequently responsible of the resources committed ; these may be outside resources, in which case he is responsible for ensuring their availability and their suitability. This may do through agreements, or coordinated plans of action.

As soon as an accident occurs, the operator is responsible for starting emergency action, inside the site. Subsequently he transfers his responsibility to the public authorities, in particular by transferring victims to the hospitals capable of dealing with contamination.

A rational approach to these responsibilities implies :

- determining the characteristics of all potential accidents
- defining the required resources ,
- organizing the resources, which must be known by all participants

CHARACTERISTICS OF ACCIDENTS

An approach comparable to that used for nuclear accidents was applied. The internationally-reported accidents were supplemented following extensive enquiries held in all french power plants and amongst nuclear engineering companies. All incidents which led, or which in other circumstances, could have caused an accident which led to victims, were analysed and extrapolated into seven typical scenarios which, in terms of the emergency resources they require, encompass all real scenarios.

The table below indicates the typical scenarios from which the following conclusions were drawn:

- accidents to equipment or during maintenance represent a greater threat for nuclear plant staff than major nuclear accidents, which primarily represent a threat to the population.

- some scenarios may induce a risk of contamination to a great number of people working on the site. Even though possibly unaffected, some of them could consider they had been exposed and demand immediate checks and treatment, hampering the organization of real emergency work. In any case it is necessary to check a great number of personnel, this needing a special organization.
- finally the risk of multi-traumata and the complexity of the plant mean that not all victims will be discovered immediately, preventing accurate classification of the urgency.

scenarios	Injuries and or Burns		Asphyxia	contaminated		Exposed		
	serious	slight		to be checked	real	0 to 0,3 Sv	0,3 to 1 Sv	more than 1 Sv
1 Failure of a steam pipe	15							
2 Turbine burst on reactor shut-down	5	25						
3 Primary pump oil fire	10		10					
4 Primary pump motor dropped on the pool	5			5	5		5	
5 Gaz tank explosion	8			8	8	40		
6 Steam generator tube burst, valve open	5			5	5			
7 Entry into red zone				100	100			5
	1			2400				1

As an example, scenario N°4 illustrates one of the series of worst-case assumptions used. A sling breaks when a primary coolant pump is being handled ; the motor drops onto the cofferdam between the two half-pools in the reactor building. The cofferdam distorts, allowing water to flood the reactor-side pool and contaminate workers in the compartments. The internal structures placed in the other compartment become uncovered, exposing other workers on the pool floor, to a high dose rate while two teams of specialists are preparing other operations.

All the victims are irradiated, including 5 exposed to a total dose between 0,3 and 1 Sv, 13 of them are seriously injured and contaminated.

RESOURCES

LEVEL ONE The human resources available in the plant differ between working hours and non-working hours but the number of victims varies in the same way. The shift staff is the first to be informed of an accident by a special telephone reserved for this purpose, always available in each control-room. This staff provides the first team of 5, most of them trained

in emergency work : an assistant shift foreman and 4 members. This shift uses the fire-fighting installations and portable equipment.

LEVEL TWO The VICTIM RELIEF PLAN is part of the INTERNAL EMERGENCY PLAN (IEP), prepared by all nuclear plants to cover all types of accidents, particularly major nuclear accidents. A rotating on call system of the personnel at home, ensures the setting up of an emergency organization providing the following resources :

- a "Management Command Post" headed by one of the plant's managers, to coordinate emergency actions,
- a "Local Command Post", headed by an operation engineer to control the damaged unit and minimize the effects of the accident,
- a "Resources Command Post", headed by a maintenance engineer, responsible for providing any exceptional equipment required,
- at least one nurse on-call in permanent connection by phone with an industrial doctor specialized in nuclear accidents, who can reach the site, if necessary, within less than 3 hours.

LEVEL THREE The IEP of a nuclear plant is closely coordinated with the SPECIAL EMERGENCY PLAN (SEP) organized by authorities of the "DEPARTEMENT", who have two emergency organizations under their control :

- FIRE EMERGENCY UNITS, mainly specialized in "technical" work (fire-fighting, explosions, etc...) whose tasks include finding, rescuing and evacuating the injured and asphyxiated. These units are part of a national structure and can, therefore, increase their capacity by calling in regional or, if necessary, national resources.
- EMERGENCY MEDICAL SERVICE (known by its acronym, SAMU) which is part of hospital services in the Departement. The SAMU possesses a main control center and mobile medical units (doctors, reanimation specialists, fully-equipped ambulances) and, through mutual-aid agreements, can call in SAMU units from other Departement.

A member of the plant's staff, specialized in first-aid and decontamination, accompanies to the civil hospital any injured people who cannot be completely decontaminated on the site. He takes the responsibility for all decontamination problems during treatment, including responsibility for preventing the spread of contamination into the hospital. Each plant has an agreement with at least one hospital, specifying the responsibilities and procedures involved.

LEVEL FOUR To overcome any real or psychological difficulties involved in moving contaminated victims into a civil hospital, agreements are also made with regional military hospitals who are particularly well equipped for this type of work. In addition, three agreements have been reached, on a national scale, with :

- the "INSTITUT CURIE", to treat a limited number of highly irradiated victims,
- the "SERVICE CENTRAL DE SANTE DES ARMEES" (PERCY hospital), to treat a large number of burn or irradiation victims,
- the "INSTITUT DE PROTECTION ET DE SURETE NUCLEAIRE", to analyse hematological, cytogenetic neurophysiological balances and evaluate doses

Finally the SERVICE CENTRAL DE PROTECTION CONTRE LES RAYONNEMENTS IONISANTS possesses mobile (trucks, coaches, etc...) anthropogammametric equipment to carry out very large-scale checks.

EMERGENCY ORGANIZATION

The principles applied to the organization of internal and outside resources are those proposed by the "medical aid in catastrophes", a field which was highly developed in France. These principles aim at constantly coordinating and optimizing the use of all emergency resources by quickly setting up :

- a strong hierarchical structure including an "general emergency directorate", over an "emergency technical management " and an "emergency medical management",
- a SORTING AND TREATMENT CENTER (STC) close to the accident to group and quickly classify all the victims,
- an EVACUATION NORIA ie a "small noria" between the accident site and the "Sorting and Treatment Center", and several "major noria", between the STC and hospitals, the STC and the infirmary decontamination rooms, etc
- a CENTRAL EMERGENCY STATION where men and vehicles waiting to intervene are grouped,
- an INFORMATION ROOM to provide information to families and media.

The chronological sequence following a serious accident outside normal working hours could be as follows, (times are given in minutes) :

- 0 ALERT- Call from the control room to the first-aid shift staff

- 5 RECONNAISSANCE-First emergency operations
 - the assistant foreman automatically becomes "emergency manager" and has the control of the team of the 4 first-aid shift personnel
 - a member of the team fight against the fire, supported and protected by a second member,
 - the third member of the team becomes the first "medical manager". he lists the victims and gives first aid
 - the fourth member is available either for technical or medical aid

- 20 INTERNAL EMERGENCY PLAN IMPLEMENTED
 - the Management Command Post manager (i e the plant manager) takes over from the system shift foreman to manage emergency activities,
 - the team members are replaced by on-call first-aid workers,
 - a Sorting and Treatment Center is organized close to the accident,
 - the on-call nurse or on-call industrial doctor may take over as "medical manager" if their higher skill are not necessary to deal with extremely urgent victims,
 - the infirmary is open, particularly for decontamination,
 - the RCP manager sends staff to the plant entrance to guide outside emergency resources called in and then, set up one or several check stations at exits from controlled zones or outside the site.

- 30 SPECIAL EMERGENCY PLAN IMPLEMENTED
 - a medical team (SAMU) arrives. The doctor of this team may take over as medical manager. The first fire emergency unit arrives to help fire-fighting under the organization of the plant staff.

- 60 two SAMU teams and several other emergency units arrive.

- 120 the last two SAMU teams arrive at the site.

CONCLUSIONS

This new organization makes the best of the resources available and allows all victims to be dealt with in less than 3 1/2 hours. However, both internal and outside resources must regularly take part in full-scale exercises to ensure coherent, and efficient cooperation.

BASES TECHNIQUES DES PLANS PARTICULIERS D'INTERVENTION DES SITES NUCLEAIRES

J.P. MAIGNE - J. COLLINET

CEA/INSTITUT DE PROTECTION ET DE SURETE NUCLEAIRE

Département de Protection de l'Environnement et des Installations

B.P. n° 6 - 92265 FONTENAY-AUX-ROSES CEDEX - FRANCE

ABSTRACT

Off-site emergency planning for french nuclear sites

A method is suggested to elaborate, on realistic technical basis, an off-site emergency plan for a nuclear site. This method gives an homogeneous and exhaustive structure to guide :

- the identification of the representative accidents that have to be taken into account in the design of an off-site plan, according to the different installations, nuclear or not, likely to be set up on the site,
- the assessment of this representative accident consequences on the environment and the population,
- the forecast and the planning, in the off-site emergency plan, of adequate counter-measures implementation with regard to this environment and the population.

1 - INTRODUCTION

Malgré les dispositions préventives prises au cours de la conception et de l'exploitation des installations nucléaires, il n'est pas impossible que les exploitants et les pouvoirs publics aient un jour à faire face à une situation accidentelle grave.

Afin de gérer au mieux une telle situation, de remettre l'installation dans un état sûr, de limiter les conséquences éventuelles pour l'environnement et les populations, divers plans d'urgence précisément spécifiés en terme de responsabilités, d'organisation et de moyens ont été établis. Le Plan Particulier d'Intervention (PPI) d'un site nucléaire est l'un d'eux. Son objectif est de prévoir et de planifier la mise en oeuvre, sous l'autorité du préfet, de moyens appropriés de secours dans la phase accidentelle à court terme.

Les différents niveaux d'organisation et des moyens prévus en fonction de la gravité de la situation à gérer ainsi que les modalités de leur mise en oeuvre sont définis de la façon suivante :

- le niveau 1 du PPI correspondant aux situations accidentelles à caractère non radiologique et/ou non toxique qui peuvent résulter des risques classiques, inhérents à toute installation industrielle (incendie, explosion, émission de matières toxiques, ...). Ces situations ne devraient pas conduire à des conséquences importantes dans l'environnement. A ce niveau, le PPI a essentiellement pour objet l'information des populations et des autorités administratives d'une part, l'organisation de l'intervention éventuelle de moyens de secours extérieurs au site, à l'appel de l'exploitant, d'autre part ;

- le niveau 2 du PPI doit permettre de gérer des situations accidentelles à caractère radiologique et/ou toxique dont les conséquences restent d'ampleur limitée à l'extérieur du site, compte tenu des dispositions prises à la conception et dans l'exploitation des installations pour limiter les conséquences de ces accidents (ordre de grandeur des accidents de dimensionnement). A ce niveau, le PPI a le même objectif qu'au niveau 1 mais s'inscrit dans une organisation plus importante, à l'échelle régionale et nationale, et prévoit la possibilité de la mise en oeuvre de moyens plus importants, notamment de moyens spécialisés ;

- le niveau 3 du PPI concerne les accidents les plus graves envisageables qui pourraient conduire à des conséquences radiologiques et/ou toxiques importantes dans l'environnement, en l'absence de la mise en oeuvre des contre-mesures prévues à ce niveau.

La décision effective d'application des contre-mesures prévues dans le niveau 3 du PPI (confinement, évacuation des populations, ...), n'interviendrait, sur la base des niveaux d'intervention recommandés par la CIPR 40 en particulier, qu'en fonction de l'évaluation des conséquences et des délais prévisibles, effectuée par les équipes de crise au cours de l'accident même, à partir des données disponibles comprenant éventuellement des mesures dans l'environnement.

Sur le plan pratique, l'appréciation des dispositions et des moyens associés à prévoir dans le PPI nécessite la définition d'un ou plusieurs "termes sources", représentatifs des rejets maximaux auxquels peuvent conduire les différentes installations du site en cas d'accident. Cette définition repose sur l'évaluation réaliste de scénarios d'accidents et de la dispersion de produits dangereux qui en résulterait.

Les dispositions à prévoir sont déterminées à partir des effets éventuels sur la santé, qualifiés et quantifiés sur la base des données radiologiques et/ou toxicologiques.

II - IDENTIFICATION DES SITUATIONS ACCIDENTELLES A RETENIR DANS UN PPI (SCENARIOS)

II.1 - Initiateurs

On retient les initiateurs suivants :

- criticité,
- incendie d'origine interne ou externe à l'installation,
- explosion d'origine interne ou externe à l'installation,
- fuite de matières radioactives et/ou toxiques.

II.2 - Classement des installations du site

Les scénarios d'accidents envisageables étant de nature différente selon le type d'installation, on a retenu la classification suivante :

- réacteurs nucléaires électrogènes (REP, UNGG, rapides),
- réacteurs nucléaires expérimentaux,
- usines, ateliers, laboratoires, installations de stockage mettant en oeuvre des matières nucléaires (cycle du combustible, Centre d'Etudes Nucléaires),
- installations industrielles non nucléaires qui peuvent présenter en situation accidentelle un risque pour les populations et l'environnement, soit par elles-mêmes, soit par l'impact de cette situation accidentelle sur les autres installations du site, nucléaires en particulier (installations mettant en oeuvre de l'hydrogène, du propane, du fioul, du sodium, ...).

II.3 - Termes-sources

De manière générale, pour chacune des installations du site, selon son type (Cf. II.2) et en fonction des initiateurs possibles (Cf. II.1), on recherche les scénarios réalistes des accidents les plus graves envisageables qui pourraient conduire à des conséquences radiologiques et/ou toxiques à l'extérieur du site. Cette recherche conduit, pour l'installation considérée, à la définition de termes-sources caractérisés par les activités des différents produits radioactifs et/ou les quantités de produits dangereux rejetées et une cinétique associée au rejet.

II.3.1 - Réacteurs nucléaires

Pour les réacteurs nucléaires électrogènes, les scénarios accidentels consistent à étudier le comportement du confinement après une fusion du cœur de ces réacteurs, situation relevant du domaine "hors dimensionnement" considérée actuellement comme enveloppe par ses conséquences à l'extérieur du site des situations accidentelles justiciables de la mise en œuvre du PPI.

Pour les réacteurs nucléaires expérimentaux, les scénarios accidentels à retenir pour l'établissement du PPI du site concerné et les termes-sources en résultant, sont recherchés au cas par cas, compte tenu des caractéristiques de conception et de fonctionnement propres à chaque réacteur.

II.3.2 - Usines, ateliers, laboratoires et stockages nucléaires

Dans le cas des usines, ateliers, laboratoires et stockages nucléaires, la démarche de l'étude des accidents graves diffère selon la nature du confinement primaire des matières nucléaires pouvant être mises en jeu lors de l'accident considéré :

- si les matières radioactives contenues dans l'installation bénéficient d'un confinement primaire par conception, à l'intérieur d'un gainage, les scénarios accidentels à retenir éventuellement dans le PPI, sont ceux qui peuvent conduire à une perte importante de l'intégrité de ce gainage et à la dispersion des matières dans l'environnement.
- si les matières nucléaires contenues dans l'installation considérée ne bénéficient pas d'un tel confinement primaire, on évalue les quantités de matières radioactives disponibles à l'intérieur du confinement pour un rejet éventuel qui sont considérées comme enveloppes de ce qui est envisageable de manière réaliste.

Les termes-sources sont alors définis par un niveau d'activité et une cinétique associée.

II.3.3 - Installations non nucléaires

Dans le cadre du PPI, il convient d'examiner les situations accidentelles qui pourraient affecter des installations industrielles non nucléaires implantées sur le site ou au voisinage de celui-ci, en particulier les installations classées pour la protection de l'environnement (ICPE), et présenter un risque pour les populations, soit par leur impact sur les installations du site voisines, nucléaires notamment, soit par elles-mêmes lorsqu'elles affectent des installations situées sur le site.

La première étape de cet examen consiste à établir un recensement aussi précis et exhaustif que possible des installations concernées du site ; on s'appuie essentiellement à ce stade sur la nomenclature des installations classées. A partir de ce recensement, deux catégories d'installations sont distinguées.

- les installations du site susceptibles de rejeter en situation accidentelle les produits toxiques qu'elles utilisent (par exemple, stockage d'acide fluorhydrique, de sodium, ...),

- les installations du site ou extérieures au site mettant en oeuvre des produits inflammables qui pourraient par explosion sur place de ces produits ou de la nappe dérivante éventuellement formée à la suite d'une fuite, conduire à une situation accidentelle grave sur des installations voisines du site, nucléaires notamment.

Des scénarios accidentels réalistes pour chaque installation sont alors définis et les rejets dans l'environnement qui peuvent en résulter sont évalués : on s'appuie, d'une part sur des évaluations théoriques a priori (calcul du débit de fuite d'un stockage, masse pouvant exploser et surpression engendrée par l'explosion de cette masse sur une installation, ...), d'autre part sur des données expérimentales ou tirées du retour d'expérience (fuite d'UF₆, feux de sodium, ...).

III - EVALUATION DES CONSEQUENCES SUR L'ENVIRONNEMENT ET LES POPULATIONS DES REJETS RESULTANT DES SITUATIONS ACCIDENTELLES RETENUES POUR LE PPI

L'évaluation des transferts dans l'environnement des rejets résultant des situations accidentelles retenues (Cf. II), est effectuée à partir de modèles de dispersion de ces rejets dans l'air, l'eau et le sol.

Pour la détermination des contre-mesures de confinement ou d'évacuation des populations à prendre à court terme (objet du PPI), la voie de transfert par l'air est la plus critique : c'est à partir de l'évaluation des transferts des produits dangereux par cette voie que seront déterminées les zones pouvant nécessiter l'application de contre-mesures. L'évaluation des transferts en fonction de la distance au point de rejet est effectuée au moyen de codes de dispersion atmosphérique adaptés à chaque cas : rejet gazeux ou assimilable à un rejet gazeux, rejet de gaz lourd, rejet liquide, compte tenu de la géométrie de la source (ponctuelle, surfacique, volumique) et de la cinétique du rejet.

On retient pour cette évaluation des données météorologiques relatives au site réalistes, mais toutefois pessimistes au plan des coefficients de transfert atmosphérique.

Toujours par souci de réalisme, il est également tenu compte éventuellement de l'effet de bottement de la direction du vent ou cours du temps.

Les conséquences radiologiques et/ou toxiques des transferts sont ensuite calculées selon les méthodes classiques, les résultats étant généralement exprimés, pour les premières en équivalents de dose engagés durant l'accident par irradiation externe et/ou interne, pour les secondes, en concentrations des produits dans l'air associées aux durées d'exposition à ces concentrations.

IV - DEFINITION DES CONTRE-MESURES A PREVOIR DANS UN PPI

La définition des zones de confinement ou d'évacuation des populations repose sur l'examen des conséquences radiologiques et /ou toxiques, telles qu'elles sont évaluées en III, des situations accidentelles retenues selon les principes proposés en II, en regard, au plan radiologique, des niveaux d'intervention proposés par la publication n° 40 de la CIPR, et, au plan de la toxicité, des données françaises ou étrangères les plus récentes concernant les produits mis en cause.

Les données classiques en matière de toxicité sont constituées d'abaques qui représentent les seuils d'apparition sur l'homme d'effets toxiques croissants du produit considéré (en général : irritation, malaise, danger, décès) en fonction de sa concentration dans l'air et de la durée d'exposition à cette concentration.

Lorsque de telles données n'existent pas, on utilise les repères que constituent pour un produit donné les valeurs limites d'exposition à court terme (VLE) ou les valeurs limites de moyenne d'exposition (VME) pour les travailleurs, publiées en particulier par l'Institut National de Recherche en Sécurité (INRS).

Sur ces bases, on retient, pour l'ensemble des situations accidentelles examinées (Cf. II) celles qui nécessitent, selon les critères ci-dessus, la mise en oeuvre de contre-mesures.

Ces situations et leurs conséquences doivent être répertoriées dans le PPI ainsi que les zones concernées par les contre-mesures.

Les modalités et moyens pratiques de la mise en oeuvre des contre-mesures sont à définir par les autorités publiques compétentes. Compte tenu en particulier des courts délais d'intervention que requièrent certaines situations accidentelles à cinétique rapide, des contre-mesures particulières ponctuelles, spécifiques au site, peuvent être mises à la charge de l'exploitant au nom des pouvoirs publics avant l'intervention effective de ceux-ci.

V - CONCLUSION

La méthodologie proposée ci-dessus constitue un canevas structuré, homogène et exhaustif pour élaborer, sur des bases techniques fondées, le PPI d'un site nucléaire.

Elle a d'ores et déjà été appliquée à différents sites nucléaires français.

MAKING UP DECISION SUPPORT SYSTEM IN NUCLEAR EMERGENCY
———FRAMEWORK OF DECISIONS———

Y.Nakashima* , T.Suzuki** and A.Nagai**

- * Department of Nuclear Engineering, School of Engineering, Nagoya University, Furo-Cho, Chikusa-Ku, Nagoya (〒464-01).
** Nuclear Safety Section, Nuclear Safety Research Association, Hibiya-dai building, No.1202, Uchisaiwai-Cho, Chiyoda-Ku, Tokyo (〒100), Japan

ABSTRACT

In the case of nuclear emergency, decision will be made at various situations. Decisions are made to minimize detrimental effects to the population and environment of interest. Many materials and data are necessary. In the present study, the authors focus on making up the decision support system (DSS) in a nuclear emergency to help a decision-maker (a prefectural governor or a co-prefectural governor) in the headquarters of countermeasure against the emergency. As a first step to make up the system, the framework of the system is given in the following.

INTRODUCTION

There have been many natural disasters in our country and some experiences learnt from the disasters would be available to the situations in nuclear emergencies. One have experienced to some extent natural disasters everywhere in our country, accompanying recommendation of relocation due to landslide by heavy rain, for example. Since the naturally occurring phenomena could be felt by one's senses, one could apply his experiences activating his own script in natural disasters.

The decision-maker for the case recommending intervention measures in the headquarters of countermeasure against the emergency will be a prefectural governor or a co-prefectural one. It is important to prepare for nuclear emergency paying attention to the similarities and differences between natural disasters and the situations being supposed in the emergency. The authors discuss a framework of the decision in the emergency to support the decision-maker.

DECISION S IN NUCLEAR EMERGENCY OUTSIDE FACILITY

In the case of nuclear emergency, local authority set up the headquarters of countermeasure by the instruction of the central conference on countermeasure for disasters based on information from the nuclear facility, or by the judgement based on the indication of fixed environmental monitors above 10 μ Gy/h or dose predicted over 5 mSv.

A prefectural governor or a co-prefectural governor will be a head, and make decisions in various situations with assistance of the comments of senior advisers such as radiation protection and safety.

Stages of Decisions

With the declaration of nuclear emergency, environmental emergency monitoring will be made according to the procedure in advance. The decision-making in emergency have to be made based on information from the monitoring, economic and social factors. The decision-making will be done for (a)sheltering in the house, (b)sheltering in a PS concrete building, (c)evacuation, (d)restriction of area, food and water, (e)restriction of shipment for agricultural products, (f)cleanup of the environment ((d)-(f) are in the case of environmental contamination) and so on according to the situations. Based on justification and optimization procedure, decisions will be made after discussion on the alternatives and their feasibility. It is necessary to evaluate the cost of unit collective dose in the case of the emergency. As tentative value, the authors adopt the cost of ten times of D_0 -value for workers in normal practices⁴⁾.

Factors Specific to Local Site to Support Decisions

In the case of nuclear emergency, the local factors specific to the site have to be taken into account. The main factors include the followings; (a)populations (according to kinds of occupations and earnings), (b)distribution of populations, (c)agricultural products in each season, shipment and consumption of the products, (d)the data on the fishery products, shipment and consumption of the products, (e)network of roads, land and maritime transportation, (f)types of houses and building (including the characteristics of surfaces), (g)geological and geographical data (types of soil, agricultural field, plants, forest, and so on), (h)data on water resources, (i)equipments applicable to environmental cleanup, (j)data on societies, local culture and custom, and so on. On the introduction of intervention, economic and social data are important specially in comparison of predicted detriments. It is preferable for these basic factors to be incorporated into database. Some data in the database will be also applicable to decision-making in natural disasters. One could feel risk from natural disaster with his senses. Since the detriment could not clearly be felt in nuclear emergencies, it is important to make decisions referring the objective data.

CONSTITUTION OF DSS

In the case of the emergency, strategic and tactical decisions will be important. The former ones would be made to minimize (or to optimize) detriment from the view point

of the whole emergency, and the latter ones would be made to reduce hazard in the scene (to select routes of minimum exposure for refuge in the case of relocation or sheltering in a PS concrete building, for example).

DSS includes database management software, model-base management software and dialogue generation software²⁾. Major parts of DSS are classified into knowledge information system and modeling support system. These give information on the model necessary to the decisions after systematic referring knowledge on disasters in the database. The authors intend to introduce Fuzzy theory for judgement in the scene accompanying uncertain factors. Figure 1 give a conceptual framework of the present DSS.

CONCLUDING REMARK

In the present study, a decision support system in nuclear emergency was discussed. However, the system is just begun to start. The content of database and model-base necessary in nuclear emergency will be gradually revealing. Since the α -value in the emergency is the most important factor in comparison of the detriments, further discussion on the value will be needed.

REFERENCES

1. Nakashima, Y. and Doi, M., 1986, Study of the System of Dose Limitation: Long Term Variation of the α -Value in Japan, IAEA SM-285/06, 519-528.
2. Sprague Jr., R.D. and Carlson, E.D., 1982, Building Effective Decision Support Systems, Prentice-Hall, Inc.

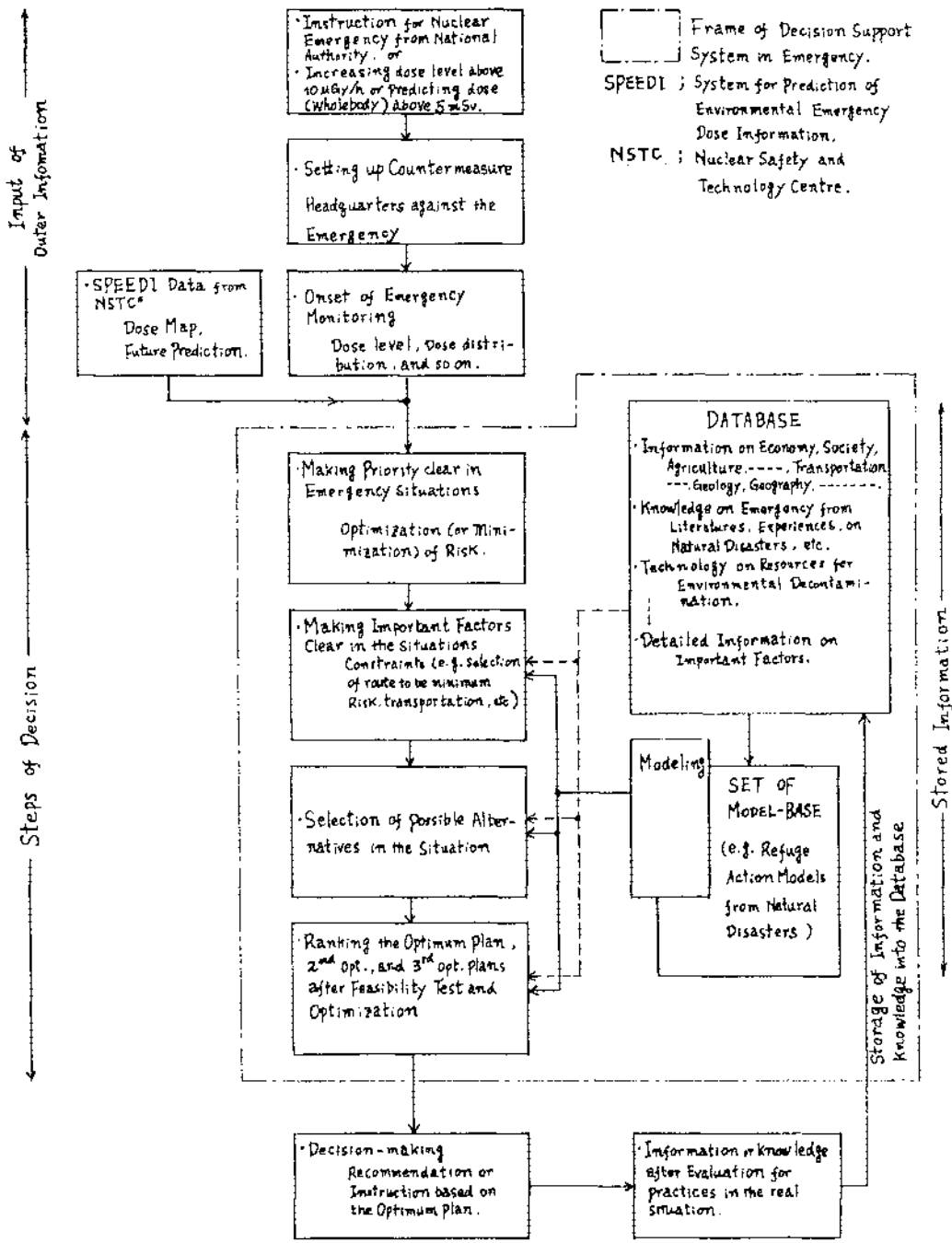

Fig.1 Conceptual Constitution of Decision-making in Nuclear Emergency

SPACE-TIME CONCEPT FOR ESTABLISHMENT OF INTERVENTION LEVELS FOR
OFF-SITE RADIATION EMERGENCIES

V.K. Gupta and T.N. Krishnamurthi
Atomic Energy Regulatory Board
Bombay - 400 094, India

D. Krishnan and K.K. Narayanan
Health, Safety and Environment Group
BARC, Bombay - 400 085, India
and

A.R. Sundararajan
Health Physics & Safety Research Programme
IGCAR, Kalpakkam - 603102, India

ABSTRACT

Intervention Levels (ILs) and Derived Intervention Levels (DILs) for initiating countermeasures in public domain following a nuclear accident or radiation emergency are established in advance. Public regime is divided in Domain 1,2 and 3 incorporating space-time concept to meet ICRP-40 recommendations. ILs in dose ranges from 1 mSv to 500 mSv to whole-body and 50 mSv to 2500 mSv to thyroid are proposed. A correlation between gamma dose rate from ground contamination and whole-body dose and inhalation thyroid dose is established to workout DILs. Relationship to obtain period of persistence and completion of countermeasure is also proposed. DILs for important radionuclide concentration in major food items are suggested.

BASES FOR INTERVENTION LEVELS

Accident in a nuclear installation, giving rise to radiological consequences in public domain, may call for implementation of countermeasures (intervention) for protection of public. Thus, there is a need to establish ILs and DILs in advance so that appropriate countermeasures could be undertaken in a planned manner. System of radiological protection for intervention is based on : i) the proposed intervention should do more good than harm; ii) the form, scale and duration of intervention should be optimised. Dose limits used for normal operations do not apply in the case of intervention (1).

The Sets of lower and upper levels of ILs are based on : a) serious nonstochastic (deterministic) effects should be avoided by introduction of countermeasures to limit individual dose to levels below the thresholds for these effects, b) the risk from stochastic effects should be limited by introducing countermeasures which achieve a positive net benefit to the individuals involved and c) the overall incidence of stochastic effects should be limited, as far as reasonably practicable, by reducing the collective dose equivalent (2).

ILs should be so selected that the dose criteria prescribed for Design Basis Accidents (DBA) in nuclear power plants, which dictate the design of engineered safety features, if exceeded only, should pose radiological consequences requiring implementation of disruptive countermeasures such as evacuation. Averting exposure by sheltering, administration of stable iodine or control of food stuffs for a limited period may be acceptable for

SPACE			
	NEAR FIELD (A ₁)	INTERMEDIATE FIELD (A ₂)	FAR FIELD (A ₃)
TIME			
EARLY PHASE (B ₁)	A ₁ -B ₁	A ₂ -B ₁	A ₃ -B ₁
INTERMEDIATE PHASE (B ₂)	A ₁ -B ₂	A ₂ -B ₂	A ₃ -B ₂
LATE PHASE (B ₃)	A ₁ -B ₃	A ₂ -B ₃	A ₃ -B ₃

Figure 1: SPACE-TIME DOMAIN ILLUSTRATION FOR EMERGENCY PREPAREDNESS PLANS accidents enveloping DBA.

Three Space-Time domains are identified on the basis of these principles for establishing ILs. These are; Domain 1: Near Field - Early Phase (A₁- B₁); Domain 2 : Near Field - Intermediate Phase (A₁-B₂) ; Intermediate Field - Early Phase (A₂-B₁) ; and Intermediate Field - Intermediate Phase (A₂-B₂) and Domain 3: Near Field -Late Phase (A₁-B₃); Intermediate Field - Late Phase (A₂-B₃); Far Field - Early Phase (A₃-B₁); - Far Field - Intermediate Phase (A₃-B₂); and Far Field - Late Phase(A₃-B₃). These are illustrated in figure 1.

Physical boundaries of domains in space and time are dependent on a large number of variable parameters such as, source term; duration of release, atmospheric conditions, etc. Thus, identification of these boundaries in case of an accident leading to atmospheric release of radioactive material would require multiple measurements and evaluations.

INTERVENTION LEVELS

Administration of stable iodine, sheltering, evacuation and control of food stuffs are considered important countermeasures for averting dose in the short term. ILs, suggested for these countermeasures for the three domains are summarised in Table 1 and are given in a range - lower and upper. If assessed release and measurements confirm that lower levels of ILs are not likely to be exceeded, countermeasures need not be initiated. If lower levels are likely to be exceeded, countermeasures should be initiated and completed such that upper levels of ILs are not exceeded. Persons in Domain 1, whose estimated exposures are in excess of upper levels of ILs of dose, may need special attention including medical care. Bases for adopting ILs are : Domain 1: Domain 1 is a low population zone. It is physically nearest to plant. ILs are based on prevention of serious nonstochastic effects. Objective of countermeasures viz., administration of stable iodine, sheltering and/or evacuation is to limit individual doses so as to avoid serious nonstochastic effects. Inhalation route for thyroid exposure would be a major consideration. Domain 2: ILs are chosen to limit stochastic risk to individual member of public. Ingestion route is likely to be the important mode of exposure. Exposure from plume, inhalation and ground contamination are expected. Countermeasures envisaged are administration of stable iodine, sheltering and / or control of food stuffs. Domain 3: ILs are aimed to reduce collective dose. Ingestion route is the predominant mode of exposure. Countermeasure recommended is control

D O M A I N	Counter- measure	Intervention Level mSv			
		Whole Body		Thyroid	
		Lower	Upper	Lower	Upper
	Administration of stable I	-	-	500	2500
1	Sheltering	20	100	-	-
	Evacuation	100	500	-	-
	Administration of stable I	-	-	50	500
2	Sheltering	5	20	-	-
	Control on food stuffs	5	20	50	500
3	Control on food stuffs	1	5	not anticipated	

Table 1: INTERVENTION LEVELS FOR DOMAINS 1, 2 & 3.

of food stuffs.

DERIVED INTERVENTION LEVELS

ILs are translated into DILs in quantities which are easily, reliably and accurately measurable. The time required for these measurements is important for initiation of countermeasures in Domain 1 & 2. Measurement of radiation field at 1 m above ground is a simple, fast and accurate parameter. A relationship is, therefore, derived to correlate gamma dose rate at 1 m from ground contamination to projected dose received by individual member of public following an accident resulting in atmospheric release. Dose rate from ground contamination DR_g is given by :

$$DR_g = X \cdot V_d \cdot DCF_i \quad \text{-----} \quad (1)$$

Where, X is time integrated airborne concentration, V_d is deposition velocity (0.01 ms^{-1}) for iodines and DCF_i is dose conversion factor ($2.9 \times 10^{-12} \text{ Sv h}^{-1} / \text{Bq m}^{-3}$). Intake of $6.76 \times 10^5 \text{ Bq}$ of iodines gives thyroid dose of 0.5 Sv, hence for a breathing rate of $1.7 \times 10^{-4} \text{ m}^3 \text{ s}^{-1}$, X is $2 \times 10^9 \text{ Bq m}^{-3}$. Using these values, DR_g calculates to $5.8 \times 10^{-5} \text{ Sv h}^{-1}$ for inhalation dose of 0.5 Sv. Thus 0.1 mSv h^{-1} dose rate from ground contamination would be equivalent to $> 0.5 \text{ Sv}$ thyroid dose from inhalation.

DR_g should be reliably available before initiating sheltering and/or evacuation. Thus, there is need to confirm these measurements over a period of time, and, if, radiation field persists, appropriate countermeasures can be initiated and completed. Total dose D_t to the whole body consists of plume dose D_p , inhalation dose D_i and ground contamination dose D_g . D_g is a

Countermeasure	Sheltering		Evacuation		
	DR _g (mSv/h)	P _h (h)	P _c (h)	DR _g (mSv/h)	P _h (h)
0.1 - 0.5	4	56	2.0 - 2.5	10	50
0.5 - 1.0	4	26	2.5 - 3.0	10	40
1.0 - 1.5	4	16	3.0 - 3.5	10	32
1.5 - 2.0	4	11	3.5 - 4.0	10	27

Table: DILs IN DOMAIN 1 FOR SHELTERING & EVACUATION

fraction $f = .3$ (4). Hours of persistence P_h , hours of completion of countermeasures P_c , ILs and DILs are related as follows:

$$(P_h + P_c) = IL \times f / DIL \quad \text{---- (2)}$$

Thus, for given DILs in terms of DR_g, IL and P_h , P_c can be calculated.

Relationships (1) and (2) are used for arriving at DILs for Domains 1 and 2. Accordingly, administration of stable iodine should be completed as soon as DR_g is more than 0.1 mSv/h and 0.01 mSv/h in Domain 1 and 2 respectively. DILs for evacuation and sheltering are given in Table 2. DILs for control of food stuffs in concentration of radionuclides, are calculated based on reference (3)

CONCLUSIONS

The ICRP-40 concept of recommending ILs for phases has been extended to incorporate space dimension. DILs are established in terms of radiation field at 1 m above contaminated ground, which is easily, reliably and accurately measurable. Proposed relationship between IL, DIL, P_h and P_c helps to adjust P_h and P_c to suit typical site conditions. Also, selective implementation of sheltering and evacuation can be undertaken depending on radiological conditions.

REFERENCES

1. 1990 Recommendations of International Commission on Radiological Protection, ICRP-60 (1990).
2. Protection of Public in the Event of Major Radiation Accidents: Principles of Planning -ICRP-40 (1984).
3. Derived Intervention Levels for Application in Controlling Radiation Doses to the Public in the Event of Nuclear Accident or Radiological Emergency; IAEA Safety Series No.81, (1986).
4. An Assessment of the Radiological Impact of the Windscale Reactor Fire, October, 1957, M.J. Crick and G.S. Linslay, NRPB-R 135, (1983).

ACKNOWLEDGMENT

Authors are thankful to Shri S.D. Soman, Chairman, Atomic Energy Regulatory Board for suggestions and discussions.

THE BRAZILIAN RADIOLOGICAL ACCIDENTS ANALYSIS METHODOLOGY
IN INDUSTRIAL GAMMA RADIOGRAPHY

F. C. A. Da Silva and L. Tauhata

Instituto de Radioproteção e Dosimetria
Comissão Nacional de Energia Nuclear
Rio de Janeiro - Brasil

ABSTRACT :

A critical review of 34 severe radiological accidents in industrial gamma radiography, that happened in 15 countries, from 1960 to 1988, was performed. It was noted that there is a need for improvement of the analysis and dose estimations methods, in order to obtain real information and good dose estimations.

The present paper shows the Brazilian radiological accidents analysis methodology in industrial gamma radiography, based in the analytical tree techniques, recommended by International Atomic Energy Agency to perform radiation protection and nuclear safety programs.

INTRODUCTION:

Industrial gamma radiography is a non-destructive technique used as nuclear application in industry. In spite of the simplicity of the technical procedure, the industrial gamma radiography is responsible for the highest number of radiological accidents in most countries. In this type of accident people are injured due to high radiation exposure given by the high activity of the small size sealed radioactive source.

The worst situation as far as exposure to radiation is concerned occurs when the radioactive source is at the unshielded position and it disconnects from the control cable. The more dramatic situation is when the radioactive source is found by individuals of the public who take it home and show it to their friends or members of the family. Depending on the source handling, absorbed dose can reach high values which cause severe injuries and even deaths.

In order to analyze a radiological accident, circumstances need to be carefully reconstructed to obtain accurate information on the number of exposed people, time of radiation exposure, probable values of absorbed dose and most affected organs. Such information help the medical treatment to be used, since they allow an estimation of the extension and type of injury, prognosis of damages, corresponding risks for the victims, etc.

As it has had some difficulties to analyze and to attend the Brazilian cases due to the absence of important data, it was elaborated a methodology, based in the analytical tree techniques, recommended by IAEA.

The Brazilian radiological accidents analysis methodology has five major constituents: investigation, reconstitution, dosimetry, conclusion and recommendation.

CONCLUSION :

The analysis of the 34 selected radiological accidents (Table 1) showed that 118 persons were highly exposed to radiation where 28 (23.7%) were workers and 90 (76.3%) were individuals of the public. Fifty five injured persons had acute exposures in localized parts of the body, mainly extremities (hands, fingers and arms) since they held the source in their hands and put it in their pockets.

The causes analyzed of radiological accidents in industrial gamma radiography showed that workers need a more detailed and wide-range training including an updating in radiation protection procedures to avoid faults in source monitoring and inadequate routine procedure.

Dose assessment methods for whole body, organs or parts of the body need to be improved to obtain good estimation of dose to help the medical treatment of victims.

The suggested methodology, that was elaborated to analyze and to attend the Brazilian cases of radiological accidents and is showed in the Figures 1 to 6, is very adequate and promising because it gives a systematic analysis procedure. This methodology enables to determine the true causes of the event, to estimate the dose with less uncertainty and to obtain recommendations to avoid future accidents.

REFERENCES :

DA SILVA, F.C.A. A Radiological Accidents Analysis Methodology in Industrial Gamma Radiography. M.Sc. Thesis. INSTITUTO MILITAR DE ENGENHARIA, Rio de Janeiro, Brasil, 1990.

INTERNATIONAL ATOMIC ENERGY AGENCY. Operation Radiation Protection: A Guide to Optimization. Safety Series No. 101, IAEA, Vienna, Austria, 1990.

INTERNATIONAL ATOMIC ENERGY AGENCY. Recommendations for the Safe Used and Regulation of Radiation Sources in Industry, Medicine, Research and Teaching. Safety Series No. 102, IAEA, Vienna, Austria, 1990.

TABLE 1: Localization of the victims of 14 radiological accidents and main health damages.

COUNTRIES	NUMBER OF ACCIDENTS	VICTIMS		DAMAGES *		
		PUBLIC	WORKER	DEATHS	AMPUTATION	INJURY
United States	12	20	13	-	3	22
Marrocco	1	26	-	6	-	-
Brazil	3	19	5	-	-	11
Argelia	1	7	-	1	1	-
Japan	1	6	-	-	-	3
England	5	-	5	-	1	4
Mexico	1	5	-	4	-	1
South Africa	1	3	-	-	1	-
Canada	2	-	2	-	1	1
Russia	1	1	-	1	-	-
West Germany	2	1	1	-	1	1
India	1	1	-	-	-	1
Iraq	1	-	1	-	-	1
Medium Orient	1	-	1	-	-	1
Argentina	1	1	-	-	1	-
15 COUNTRIES	34	90	28	12	9	46

* In this Table only the major damage is reported for each person, such as death > amputation > injury, atrophy and sterility

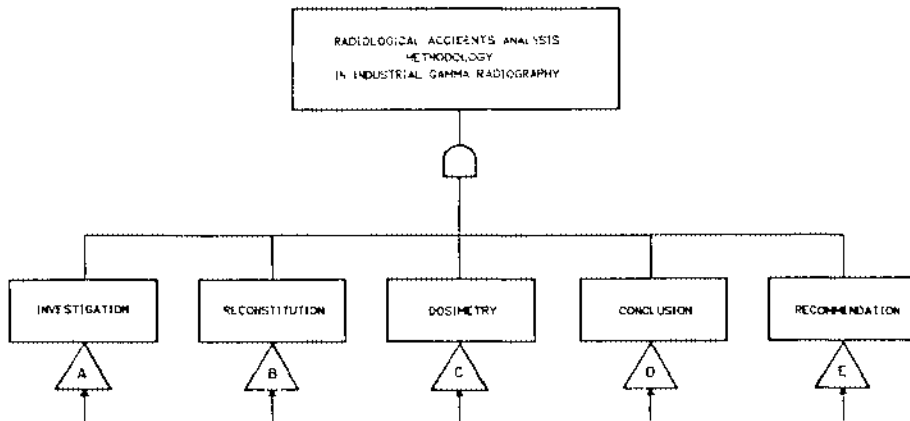

FIGURE 1 The analytical tree for the Radiological Accidents Analysis in Industrial Gamma Radiography

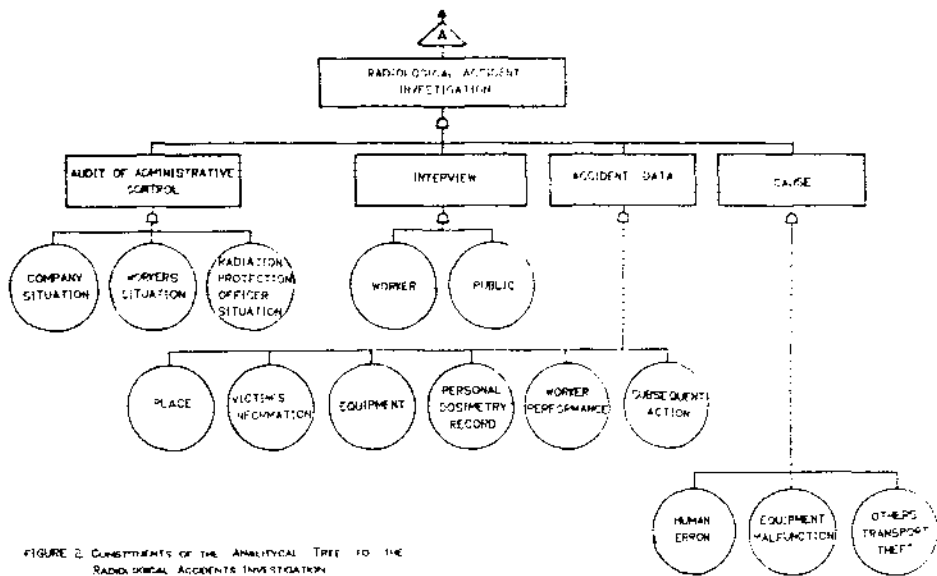

FIGURE 2. CONSTITUENTS OF THE ANALYTICAL TREE TO THE RADIOLOGICAL ACCIDENTS INVESTIGATION

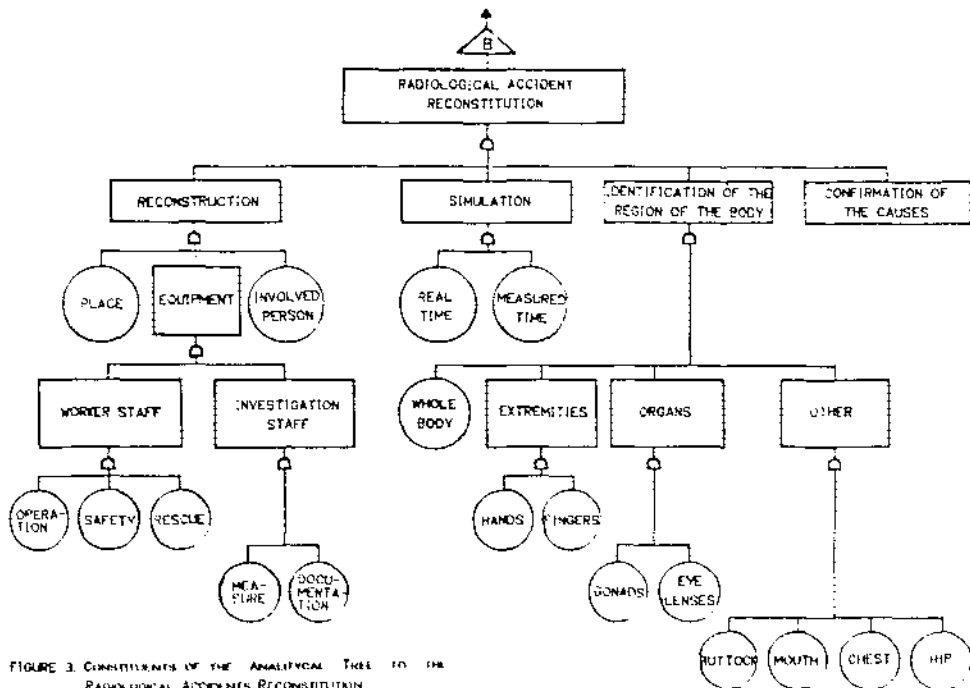

FIGURE 3. CONSTITUENTS OF THE ANALYTICAL TREE TO THE RADIOLOGICAL ACCIDENTS RECONSTITUTION

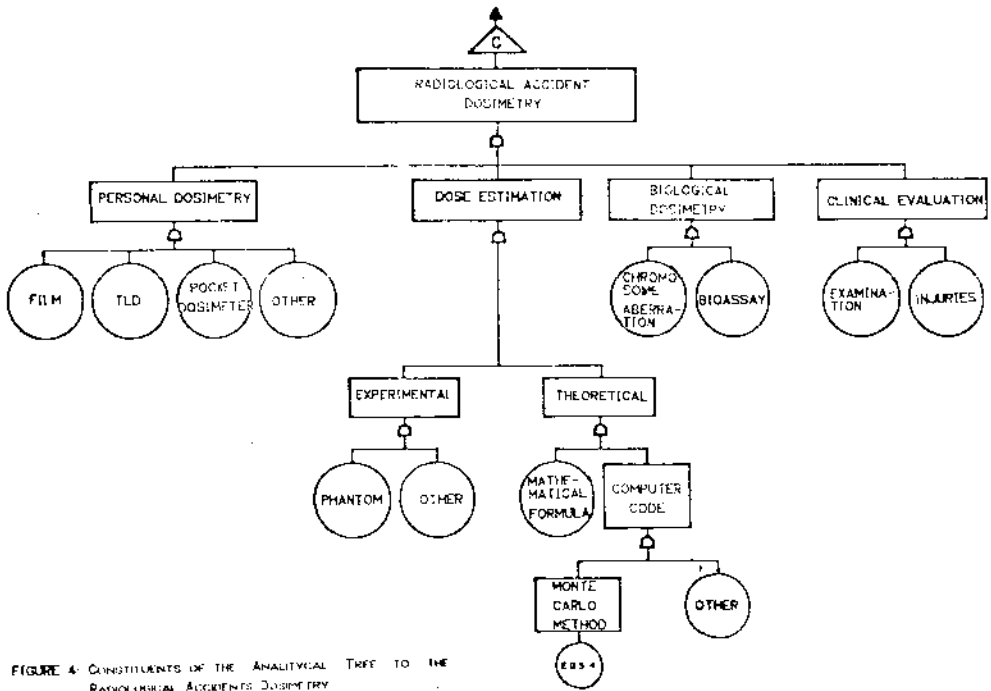

FIGURE 4. CONSTITUENTS OF THE ANALYTICAL TREE TO THE RADIOLOGICAL ACCIDENTS DOSIMETRY

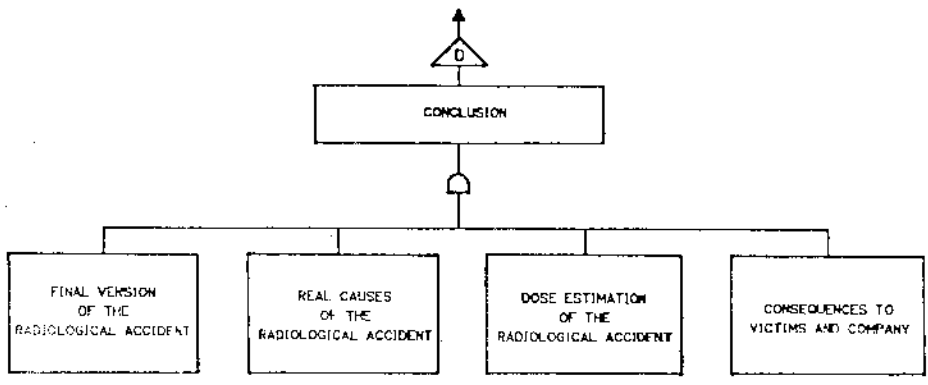

FIGURE 5. CONSTITUENTS OF THE ANALYTICAL TREE TO THE CONCLUSION IN RADIOLOGICAL ACCIDENT CASES

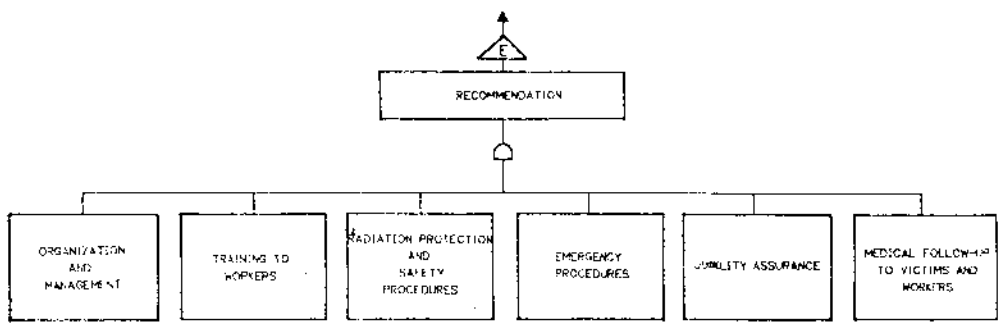

FIGURE 6. CONSTITUENTS OF THE ANALYTICAL TREE TO THE RECOMMENDATIONS IN RADIOLOGICAL ACCIDENT CASES

Decontamination Exercise at a General Hospital

B. Heaton

Department of Bio-medical Physics,
University of Aberdeen, Foresterhill,
Aberdeen AB9 2ZD, SCOTLAND.

Abstract

By using a luminescent material as a substitute for radioactive contamination a realistic assessment of the emergency plans for dealing with contaminated radiation casualties at a Regional General Hospital was made. The areas where problems arose in these plans are described and the changes now made to them given.

Introduction

Many hospitals have contingency plans to receive contaminated radiation casualties as part of the national arrangements for dealing with such events. Fortunately very few have to ever implement these plans and a real experience of how they would work is not available. Aberdeen Royal Infirmary is a receiving hospital for the North East of Scotland. Although we have no nuclear reactor or naval bases in our area we do have several research institutions and the University, all of which use quite large quantities of unsealed sources. A large air force base with strike aircraft based at it is also present. In addition to these long standing users we have had, in recent years, spent radioactive fuel occasionally passing through the area on its way to Dounreay for processing. The biggest recent influx of radioactive sources however is those introduced by various service companies to the oil industry. These are mainly large sealed sources but also include some unsealed sources. Our plans to deal with such casualties were written and prepared on very similar lines to those prepared for use in other hospitals and we had every confidence they would deal with the situation if it ever arose. As part of an on going evaluation of all emergency plans it was decided to test the plans in what would be perhaps the worst scenario.

Scenario

An accident was assumed to have taken place at one of the oil related companies resulting in the rupture of a sealed source. Casualties were restricted to two so that a realistic assessment of the plans could be made within a reasonable period of time. The clinical injuries were kept to a minimum as our decontamination procedures were being tested not the medical treatment. Sufficient clinical work had to be provided however to provide a realistic situation. One casualty was made up so as to indicate a broken tibia and facial lacerations from flying debris, the other broken ribs with a pneumothorax. Radiation contamination was simulated using a fluorescent powder. This had the very real advantage that in small quantities it was invisible to the eye but could be seen when viewed under a U.V. light. By using hand held

U.V. lights it was possible to simulate the contamination monitoring equipment that would be available. [Anthracene was used for this exercise, as this was commonly used in other areas for similar work. Tests were made to ensure that the two casualty volunteers were not sensitive to it by contaminating a small area of forearm skin a few days before the exercise. Recent recommendations on the use of anthracene for this purpose would suggest that an alternative powder should be considered]. The contamination of the casualties was restricted to quite a small area and was not visible to the naked eye. Likewise the floor around the casualties was contaminated but this again was not visible to the naked eye.

Senior management staff in all areas were aware of the exercise, mainly to stop events escalating rather than to ensure the exercise did not come to a complete stop. Most of the participants from telephone operators through to the emergency staff either did not know or were only vaguely aware that some sort of exercise was planned.

Description of Exercise

The hospital switch board was notified of the incident at 1.30p.m. and had successfully alerted all the emergency staff who had gathered with their equipment in the Accident and Emergency (A & E) department before the ambulance arrived with its casualties. If the incident had been out of normal working hours the physicists called in would have inevitably taken some time longer to appear. The first part of our plan involved covering the floor of part of our A & E department with polythene together with a "corridor" to this area from the designated entrance. It was very quickly realized this would not be possible to do in the time available before the casualties could arrive and the attempt was abandoned. Even with sheets of polythene cut to size it takes a surprising amount of time to lay and stick them down so that it is safe to walk on. Barriers were erected round the area to demarcate it. The personnel going into this controlled area put on protective clothing and other staff were positioned to service them as required.

Response of the Ambulance Crew

The crew were warned that the casualties were contaminated and they were entering (for the exercise) a radiation controlled area. They put on rubber gloves which subsequently split. If expert staff were present they would of course normally have advised them on what precautions to take. In this exercise no detailed advice was volunteered but would have been given if asked for. Likewise additional equipment held in the area would also have been provided if requested. No attempt was made by the crew to request contamination monitoring and none was undertaken. The clothes of both members of the crew became contaminated as well as the skin on their hands and knees. At the time of the exercise they were also expected to wear peaked hats at all times (this requirement has since been totally rescinded). As their hats fell over their faces and they pushed them back up, their faces and hair also became contaminated. Special 'impervious' coveralls were not normally carried on the ambulance although they were available at the ambulance depot. The ambulance became badly contaminated after they had put the casualties into it as, although they wrapped the casualties, their shoes and hands carried quite a large quantity of powder with them. During the crew's initial examination of the casualties and their treatment the contamination was spread over a much wider area. Without involving someone on site with a contamination monitor this spread of contamination

is impossible to control. Even if a monitor was available it is suspected that control would still be difficult.

Response of Accident and Emergency Department

The opportunity was taken to try out different types of protective clothing to see which was the most efficient and which the most convenient. This clothing varied from a simple white waxed paper suit with a theatre mask to a full PVC protective suit with a battery powered breathing hood. All staff wore normal disposable rubber gloves. Our plan stipulated that the ambulance men should hand over the patients at the entrance to the A & E department. Despite being aware of this they followed their normal practice and entered the area thus immediately contaminating the floor. One physicist had to be diverted from dealing with the casualties to monitor them and advise them what to do.

In the course of treating the injuries the doctor and nurses, even with "monitors" and advice available, spread the contamination to areas of the patient not previously contaminated. Our plans had laid down that staff in the controlled area should be kept to a minimum. This policy was felt to contribute to this spread as people moved from patient to patient and perhaps forgot the location of contamination on each patient. The other marked tendency was to use as little localised decontamination using swabs as possible and rely on the shower in the area to clean the rest. [The fact that the casualties were postgraduate male students and the nurses of similar age was not felt to have contributed to this].

At the end of the exercise anthracene powder was found all over the floor of the area and on the walls. The shower was generally contaminated. All individuals had some anthracene on their wrists and all but the person wearing the hood had some on their face. If it had been a real event a large part of the A & E department could have been taken out of use for several days while it was decontaminated. The consultant staff felt that even with the very small chance that a real incident would occur such a situation should not be contemplated.

Conclusions

For very little effort our procedures were tested under realistic conditions which highlighted many unsuspected inadequacies. The major one was that an alternative area required to be identified to receive contaminated patients if a large part of the A & E department was not to be under threat of being contaminated. This has now been found. A small room has been created at the very periphery of the A & E department which can, if necessary, be completely isolated without affecting the work of the A & E allowing decontamination to take place in a controlled manner. Medical equipment will have to be taken there if required but this is a minor problem. The room is completely tiled with a shower in one corner and can cope with two casualties. If more than two appeared they would have to stay outside in an Ambulance unless a life threatening situation existed. By being very prudent with the brief for this room the cost was kept to an acceptable level, even within the UK Health Service, for a room it is hoped never to use.

It was also apparent that although the hood provided complete protection it made communication with other staff and the casualties very difficult. It is now considered that the white wax suits used in conjunction with a high quality nasal mouth mask (i.e. rated for asbestos work) would suffice. It is accepted that some facial contamination may occur if loose powders

are present. Goggles should also be available. Long sterile gloves are absolutely essential, normal sterile gloves are inadequate. The stock of wellingtons also required changing - most of them were too big for the nurses.

Measuring pulse rates was difficult and a large clock with a sweep second hand would have been useful. Gauze swabs were found far more useful than disposable wipes and it was found that the stock of polythene bags for putting waste items into was soon finished. The idea of keeping the number of people involved to a minimum contributed to the spread of contamination and in future each casualty will have a "team" of people who will solely work on him/her. This will also allow much more of the contamination to be removed by local swabbing rather than using the shower.

Recommendation

All emergency plans for dealing with contaminated casualties should be tested using a real contaminant which can be spread in much the same way as a radioactive contaminant. Only by monitoring the spread of this material can a real assessment be made of the efficiency of the plans. Plans which are apparently quite adequate under routine trials can prove to have deficiencies when tested in this way.

AGRICULTURE, ENVIRONNEMENT ET NUCLEAIRE :

COMMENT REAGIR EN CAS D'ACCIDENT

G. Griperay* et R. COULON**

- * Fédération Nationale des Syndicats d'Exploitants Agricoles, Paris, France
- ** Institut de Protection et de Sûreté Nucléaire, Fontenay-aux-Roses, France

AGRICULTURE, ENVIRONMENT AND NUCLEAR USES :

HOW TO REACT IN CASE OF ACCIDENT

Presentation of a reference handbook analyzing the consequences of a nuclear accident on agriculture and how to react in order to mitigate them.

Based on the right of citizens to be informed on civil security organization, on the protection of population, goods and environment : this book is a preliminary reflexion to post-accidental planification.

INTRODUCTION

Dans le monde actuel, la communication a pris une importance considérable. Le public demande à être informé car il veut comprendre et apprécier le bien-fondé des choix faits par les instances politiques.

C'est dans ce contexte qu'a été élaboré, conjointement par un organisme professionnel, la Fédération Nationale des Syndicats d'Exploitants Agricoles, et un organisme scientifique, l'Institut de Protection et de Sûreté Nucléaire, un document intitulé "Agriculture, Environnement et Nucléaire : comment réagir en cas d'accident".

MOTIVATION ET OBJECTIFS

La FNSEA, au nom de ses adhérents, les agriculteurs, se préoccupe depuis longtemps déjà des conséquences que le développement de la filière nucléaire peut avoir sur l'agriculture : il ne faut pas oublier, en effet, que ce développement ne se fait pas dans les villes, mais à la campagne.

Jusqu'à l'accident de Tchernobyl, cette cohabitation s'est bien passée : par la suite, il en a été différemment. En effet, les agriculteurs ont été frappés de plein fouet par cet accident, à travers un flot d'informations désordonnées, contradictoires et auxquelles ils ne comprenaient pas grand chose, si ce n'est qu'il en résultait des difficultés pour écouler certaines de leurs productions.

Très rapidement, les responsables de la FNSEA, persuadés que l'information doit permettre, en ce domaine comme en d'autres, d'éviter une attitude moyennageuse et d'aborder ouvertement les problèmes éventuels, ont décidé de se rapprocher des spécialistes du nucléaire, parmi lesquels se trouvent des agronomes et des vétérinaires.

Ensemble, ils ont produit le document cité, qui a reçu un accueil étonnamment favorable, prouvant qu'il y avait là un véritable besoin.

LES DESTINATAIRES

La préoccupation principale de la FNSEA étant tournée vers ses adhérents, c'est d'abord à leur intention que le document a été préparé. Les agriculteurs connaissent bien l'environnement, ses forces et ses faiblesses : de plus, ils sont réalistes et savent bien qu'il faut parfois composer avec les événements notamment les agressions naturelles auxquelles ils sont sans cesse confrontés. Et, il faut le rappeler, ils ont été les principales victimes de l'accident de Tchernobyl.

Mais l'audience peut être beaucoup plus large, dans le monde agricole (administration, organismes publics ou professionnels, industrie agro-alimentaire, ...), vis-à-vis des associations préoccupées par les problèmes d'environnement, les médias (notamment scientifiques), les enseignants, ... et puis tout citoyen soucieux de s'informer et conscient du fait que l'environnement est son cadre de vie et l'agriculture le support de sa subsistance.

LES OBJECTIFS

L'objectif essentiel du document apparaît dans son intitulé "Comment réagir en cas d'accident". Il s'agit de donner des informations qui permettraient, en cas de crise, de prendre très vite toute initiative susceptible d'en atténuer les conséquences, puis, lorsque des consignes seraient données par les autorités compétentes, de les appliquer intelligemment. Ces informations doivent également aider le milieu agricole à sauvegarder ses intérêts et à ne pas être dépassé par une situation que certains sont tentés d'exploiter à des fins qui ne sont pas altruistes.

Pour cela, il faut non seulement intégrer l'information, mais aussi bien la comprendre. Le document s'est donc voulu explicatif, en traitant notamment des processus de transfert des éléments radioactifs de l'atteinte des productions agricoles et des conséquences des utilisations ou des transformations de ces productions.

Il fallait aussi faire précéder ceci par une information plus générale sur la radioactivité, ses effets, les moyens de s'en protéger. Il fallait enfin aborder le domaine des accidents nucléaires "Risques accidentels associés aux diverses utilisations de la radioactivité, éléments radioactifs concernés, typologie des accidents, organisation de l'intervention, mesures protectives,".

CONCEPTION DU CONTENU

De ce qui précède, découle le plan adopté qui porte sur :

- les connaissances générales ;
- les aspects liés aux accidents nucléaires, y compris les bases et l'organisation de l'intervention ;
- la contamination des milieux (atmosphère, sol, eaux, milieu naturel) ;
- la contamination des productions (légumes, fruits, lait, viande, ...) ;
- des exemples concrets.

Pour faciliter la lecture d'un document assez volumineux, on a cherché :

- > à faciliter la compréhension, en évitant les termes peu communs, en définissant les termes spécifiques, en repérant dans un index les termes importants et en utilisant un système de renvois entre parties similaires ou complémentaires ;
- > à rendre chaque "fiche" auto-porteuse (le lecteur peut ne lire que ce qui l'intéresse) et en adoptant une présentation standardisée pour les fiches "milieux" et "productions", à savoir :
 - * comment se produit la contamination ?
 - * quels sont les risques résultants ?
 - * comment s'en protéger ?
- > à équilibrer les explications théoriques et les applications pratiques ;

-> à utiliser un style direct, concis et clair et une présentation aérée et abondamment illustrée.

Cette approche, pour autant qu'elle soit réussie, ne va pas sans certains pièges. Le principal est sans doute de faire cohabiter l'exactitude scientifique et la simplicité de présentation. Difficile aussi de présenter des aspects qui sont encore en évolution ou sur lesquels il n'y a pas consensus.

CONCLUSION

Il serait illusoire de croire que l'on peut atteindre parfaitement un objectif aussi délicat, dans un domaine encore bien neuf, où tout n'est pas toujours net et précis et où la passion l'emporte bien souvent sur la raison.

Rester objectif, éviter tout catastrophisme mais aussi toute tendance lénifiante, essayer d'être bien compris : tel a été le souci des rédacteurs. Il sera fort utile de savoir s'ils y sont parvenus.

DACFOOD
Un système d'aide à la décision en cas de contamination de la chaîne alimentaire

Alain DESPRES, Antoine DIAZ & Dominique SOULATGES
CEA/Institut de Protection et de Sécurité Nucléaire
Département de Protection de la santé de l'Homme et de Dosimétrie

BP n 6 - 92265 Fontenay-aux-Roses Cedex (France)

DACFOOD
A Decision aiding-system in case of contamination of the foodchain

DACFOOD is an interactive decision-aiding software allowing:

- to calculate the doses due to the consumption of contaminated foodstuffs;
- to propose countermeasures, taking into account the type of foodstuff and the concerned radionuclides;
- to estimate the dosimetric impact, the cost and feasibility of the available countermeasures;
- to suggest a classification for sets of combined countermeasures, ie. actions, on a cost/effectiveness basis.

Introduction.

L'objectif du programme DACFOOD (Decision Aiding for Contaminated FOODstuffs) est de fournir aux décideurs les éléments d'une gestion optimisée des produits alimentaires contaminés à la suite d'un accident nucléaire. Cette gestion repose sur l'évaluation coût/efficacité des contre-mesures susceptibles d'être mises en oeuvre et sur des jugements d'experts.

Les fonctionnalités du système

L'analyse coût-efficacité repose sur deux types de données :

- des données propres à l'accident : la nature et la quantité de produits contaminés, l'activité mesurée de chaque isotope et l'activité déposée au sol;
- des données archivées de façon permanente.

Ces dernières figurent dans les bases de données suivantes :

- une base de données relative aux radionucléides (périodes radioactives, facteurs de dose);
- la base de données EUROGRID /1/, qui donne les populations, l'utilisation des sols, les productions agricoles annuelles, l'effectif du cheptel et le nombre d'emplois par type d'activité sur un réseau maillé. Cette base peut être appelée à défaut de données plus spécifiques du moment de l'accident;
- une base de données relative aux contre-mesures (coût, efficacité, faisabilité);
- une base de données relative aux différents facteurs de transfert sol-plantes;
- une base de données relative aux facteurs techniques traduisant l'impact des transformations agro-alimentaires.

Ces différentes données sont utilisées pour évaluer les doses individuelles et collectives consécutives à l'ingestion des denrées alimentaires. A ce stade, le système compare les doses individuelles aux seuils d'intervention proposés par la CIPR et aux seuils de commercialisation des denrées adoptés par la Commission des Communautés Européennes. Il en déduit s'il convient ou non de mettre en oeuvre une contre-mesure. Dans l'affirmative, le système évalue et classe les contre-mesures envisageables par le coût de l'homme-Sievert évité.

Les doses dues à l'inhalation et à l'irradiation externe sont introduites en tant que données pour le calcul des doses individuelles.

L'analyse précédemment décrite ne suffit pas, à elle seule, pour décider de la mise en oeuvre d'une contre-mesure. Plusieurs éléments, plus difficilement quantifiables et rassemblés sous le terme générique de jugements d'experts, doivent être pris en compte. Ces experts, sociologues, politiciens, économistes ou agronomes, ont naturellement des préoccupations différentes. Par exemple, un économiste pourrait prendre en compte la surproduction européenne actuelle de produits laitiers pour rejeter a priori la transformation du lait sous forme de beurre ou de poudre.

Pour introduire ces différents aspects, un système de maintien de la cohérence a été développé, qui met en évidence les contradictions entre les points de vue et recherche un compromis.

La phase actuelle de développement concerne le recueil de cette expertise. C'est une tâche difficile, qui nécessite l'identification des experts, leur sensibilisation au problème, ainsi que le recueil et l'organisation de leurs jugements sous forme de règles. Deux voies sont suivies pour parvenir à ces objectifs : la participation à des exercices de crise et l'enquête par questionnaire.

La maquette, entièrement conversationnelle, a été développée sur le logiciel GOLDWORKS. Son utilisation sur micro-calculateur nécessite une mémoire RAM de 6 Mbytes.

Exemple d'application

L'application, brièvement décrite ci-après, est issue de l'exercice de crise qui s'est déroulé sur le site de Cadarache (Bouches du Rhône, France) du 15 au 17 Octobre 1991.

Six produits alimentaires ont été retenus (salade de plein champ, pomme, raisin de table, viande d'agneau, laits de chèvre et de vache). Les services régionaux du Ministère de l'Agriculture ont pu rapidement estimer les quantités contaminées dans trois régions définies à partir des courbes d'iso-dépôt (seuls ^{131}I et ^{137}Cs ont été pris en compte).

La connaissance des rations alimentaires et la formulation d'hypothèses relatives à l'origine des produits consommés permettent de calculer les doses reçues par deux groupes de population (proche et lointain): les habitants de la zone proche sont considérés comme un groupe critique (on admet que tous les produits qu'ils consomment proviennent de la zone proche), tandis que les habitants de la zone lointaine ont une alimentation qui provient à part égale des trois zones respectivement proche, intermédiaire et lointaine.

La dose efficace reçue par les habitants de la zone proche ainsi que les limites de commercialisation conduisent à entreprendre des actions

sur toutes les productions de la zone proche, ainsi que sur la viande d'agneau, le lait de chèvre et le lait de vache de la zone intermédiaire. Pour chacun des produits alimentaires considérés, les contre-mesures envisageables sont les suivantes :

- aalade : destruction (D);
- viande : destruction (D), abattage différé (Ad) ou stockage;
- lait : destruction (D), décontamination (d) ou transformation;
- fruits : destruction (D) ou éventuellement stockage (pommes).

L'impact de chaque contre-mesure sur chaque lot de produit et pour chaque classe de consommateurs (zone et classe d'âge), ainsi que le coût de ces contre-mesures (incluant la destruction, le stockage des déchets, le transport,...) est illustré à l'aide des figures 1 et 2.

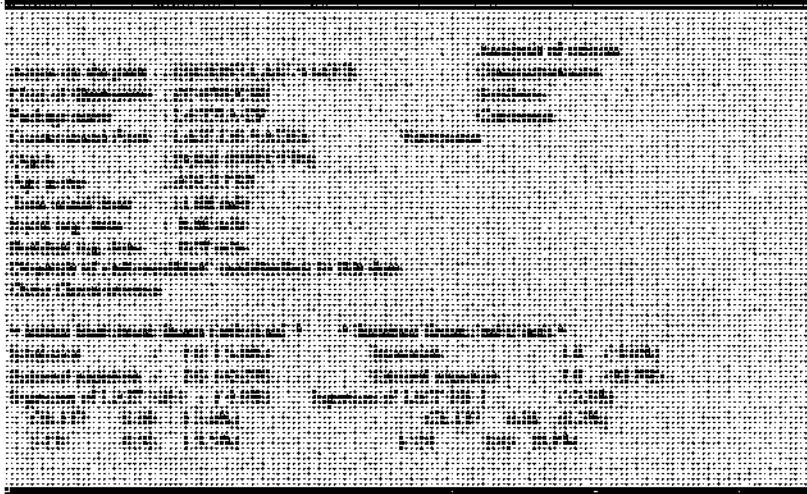

Figure 1 : Image d'écran montrant l'efficacité d'une contre-mesure

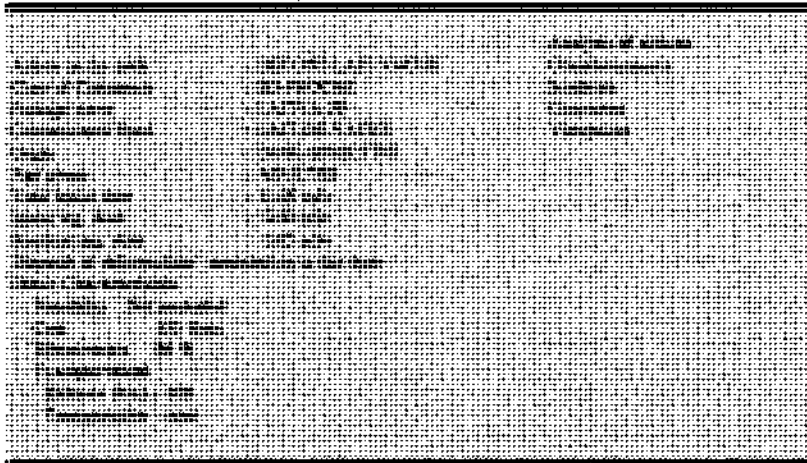

Figure 2 : Image d'écran montrant le coût d'une contre-mesure

Appliquées aux différents lots de produits, ces contre-mesures élémentaires permettent de définir des actions. Le choix d'une contre-mesure sur un lot peut être effectué, par l'opérateur ou par le système, en fonction d'un critère choisi (efficacité maximale pour une classe de consommateurs donnée, coût minimal, efficacité maximale sur la dose collective). Les actions évaluées dans le cadre de l'exercice étaient les suivantes :

Actions	Zone	Salades fruits	Lait chèvre	Lait vache	Viande
CM1	proche	D	D	D	D
	intermédiaire	-	D	D	D
CM2	proche	D	D	d	D
	intermédiaire	-	D	D	Ad
CM3	proche	D	d	d	Ad
	intermédiaire	-	D	D	Ad

Le coût et l'efficacité sur les doses individuelles sont donnés pour chaque action :

	Effic.	Coût (ECU)
CM1	90 %	6,7 E05
CM2	80 %	4,6 E05
CM3	90 %	3,7 E05

Figure 3 : Ecran de la synthèse des différentes actions envisagées.

Une telle analyse met en évidence le gain apporté par l'abattage différé, pour une perte d'efficacité relativement faible. Enfin, la décontamination du lait de la zone proche, parce qu'elle porte sur une faible quantité (5 tonnes en 10 jours), est tout à fait envisageable.

Conclusions

Au-delà de l'aide opérationnelle à la décision, l'objectif poursuivi dans la réalisation du système DACFOOD est de disposer d'un outil facilitant la réflexion des personnes impliquées dans la décision. Au stade actuel de maquettage, la participation à des exercices n'a pour but que de permettre de juger de l'intérêt de DACFOOD et de mettre en évidence ses insuffisances.

Référence.

/1/ S. BONNEFOUS, A. DESPRES

La base de données EUROGRID. Problèmes méthodologiques et développements récents. IRPA8, Montréal, 17-22 Mai 1992

Remerciements

Le système DACFOOD a bénéficié d'un financement des Communautés Européennes : Contrat d'association EURATOM/CEA. DGXII B16-122F(D).

ÉTUDE SUR LE COMPORTEMENT ÉVENTUEL DES BÉNÉVOLES APPELÉS À EFFECTUER LA DISTRIBUTION DE PILULES D'IODE EN CAS D'ACCIDENT À LA CENTRALE NUCLÉAIRE DE GENTILLY II

Dirigée par Raymond Corriveau
Unité de recherche en communication et communauté
Université du Québec à Trois-Rivières

Study Pertaining to the Distribution of Iodine Pills in the event of a Nuclear Mishap at the Gentilly II Station.

This study seeks to understand how volunteers, whose task it is to distribute iodine pills in the event of a nuclear mishap, are likely to react in such a situation. Our postulate is that the uniform application of preventive measures in an emergency situation requires that volunteers adhere to the principles of the ideological apparatus (civil authority). Our findings are that current measures are inadequate for an effective emergency strategy.

Cette recherche vise la compréhension du comportement éventuel d'un groupe de bénévoles appelés à distribuer des pilules d'iode à la population en cas d'accident nucléaire. Nous tenterons de mieux saisir, comme Lucien Goldmann (1971: 9) le postulait, non pas la conscience réelle des individus, mais bel et bien leur conscience possible. Les travaux furent menés grâce à une étroite collaboration avec le Département de santé communautaire Ste-Marie, dans le cadre de l'élaboration d'un plan de santé en cas d'accident à la centrale nucléaire Gentilly II. Rappelons qu'un aspect particulier de ce plan de santé traite du processus de distribution des pilules d'iode. Cette procédure recommandée par l'OMS (1988: 30) pose de sérieux problèmes de prévisibilité comportementale: en situation de danger appréhendé, les bénévoles voudront-ils exécuter la tâche qui leur a été confiée? C'est à partir de questions de cet ordre que nous avons orienté notre protocole de recherche.

Objectif général de la recherche

Développer une vision plus raffinée du comportement des bénévoles appelés à distribuer les pilules d'iode en situation d'urgence.

En corollaire

-fournir aux responsables un cadre de référence afin de mieux appréhender les divers comportements possibles;

-scoutenir l'effort des autorités compétentes dans leur concertation visant l'établissement de mesures d'urgence;

Objectifs spécifiques de la recherche

-identifier le comportement prévisible des individus afin d'améliorer l'efficacité des plans d'intervention en situation d'urgence;

-rendre plus apparentes les faiblesses possibles dans les mécaniques d'urgence qui pourraient relever de ces comportements éventuels;

-aider les citoyens à mieux protéger leur santé lors de situations d'urgence.

Moyens utilisés

-établir une expertise dans l'application de la Méthodologie-Q-;

-réaliser une enquête auprès des bénévoles ciblés dans le cadre des mesures d'urgence;

-produire des recommandations qui viseront à améliorer le travail des bénévoles appelés à distribuer les pilules d'iode lors d'une situation d'urgence.

Une réflexion soutenue sur la problématique des conjonctures extraordinaires nous invite donc à **postuler** que:

pour que des mesures de prévention et de coordination soient efficaces en situation d'urgence, le bénévole doit effectuer un rattachement significatif vers l'appareil idéologique.

En concordance avec notre cadre théorique, le comportement de l'individu sera vu à partir de ses rattachements idéologiques possibles. Ces rattachements constituent les variables de notre enquête.

***Établissement des variables**

Axe d'induction =====>	Rattachement à l'appareil idéologique	Rattachement au réseau idéologique primaire	Rattachement à soi (comportement narcissique)
	DSC/CLSC/Mairie/ Police/Exploitant de centrale/Sécurité publique, etc.	Famille/Parenté/ voisins/Connais- sances/Relations affectives	L'individu et ses préoccupations
Dimensions ↓			
Théorique (expression directe)	se rattache ou identifie une idéologie spécia- lisée	signale son appartenance à la famille	démontre un com- portement narcissique
Comportement individuel	respecte les lois	identifie la for- mation d'habitus coutumes, manières	priorise l'intérêt personnel
Comportement face aux autres	se conforme à la hiérarchie institutionnelle	privilégie la convivance (réseau affectif)	utilise les autres à ses propres fins

La réalisation de notre projet a nécessité l'utilisation de trois types de collectes de l'information: la méthodologie -Q-, le profil contextuel et l'animation des bénévoles. A la lumière des résultats obtenus dans l'ensemble de la démarche scientifique, nous établissons les constats suivants:

- * à ce stade-ci, la structure de distribution nous semble inopérante (selon contexte global de l'enquête);
- * toutefois l'établissement d'une telle structure nous semble difficile mais réalisable (selon les résultats spécifiques de l'enquête statistique);
- * les difficultés de mise en oeuvre relèvent de conditions liées à l'agissement des bénévoles ;
- * les difficultés rencontrées sont d'ordre organisationnel (selon le contexte global de l'enquête);
- * pour rencontrer les conditions de faisabilités souhaitées, les recommandations suivantes **doivent** être mises en application.

Recommandations

- 1 Revoir et mettre à jour la liste des bénévoles appelés à distribuer les pilules d'iode.
- 2 Structurer ou restructurer l'organisme spécifique qui encadre l'action des bénévoles. Pour être plus efficace, il faudrait revoir le rôle même que joue la Sécurité civile.
- 3 Établir un organigramme et un plan de tâche fonctionnel qui devraient tenir compte de la dispersion géographique des ressources en fonction des services à offrir.
- 4 Identifier un nombre restreint de domiciles à couvrir pour chaque bénévole. Le nombre devrait se mesurer selon le rapport temps/distance en prenant en considération une période de temps allouée à l'explication auprès des populations appelées à prendre des mesures préventives. Comme certains répondants nous l'ont mentionné, la barrière du 60 minutes est difficile à allonger. Dans une situation qui évolue rapidement, il peut être risqué de mandater des gens pour plusieurs heures, sans avoir aucun moyen de les rappeler ou de leur transmettre une information nouvelle. Ces arguments introduisent la recommandation suivante.
- 5 Assurer une formation continue et un suivi (principe de continuité) aux bénévoles en greffant leur organisme aux activités d'un corps déjà constitué. À ce stade-ci, les pompiers bénévoles nous semblent un des rares organismes à fournir des affinités suffisantes pour que le regroupement puisse être de caractère organique. Ce rapprochement permettrait également de fournir une alternative à l'utilisation du service des pompiers volontaires pour distribuer des pilules d'iode, car ces derniers pourraient devoir répondre en même temps à une urgence simultanée reliée ou non à l'accident nucléaire. Un tel rapprochement posséderait aussi le mérite de fournir une certaine reconnaissance et une certaine gratification à ceux qui manifestent un intérêt communautaire.
- 6 Prévoir une formation scientifique minimale pour les bénévoles, formation qui devrait comprendre un volet relié aux effets anxiogènes de la nouvelle dont ils seront porteurs. Cette formation s'avère importante d'autant plus qu'il s'agit d'une des rares modalités qui pourrait amoindrir l'«Évacuation Shadow» (Zeigler & Johnson, 84; 208).
- 7 Mettre sur pied des exercices périodiques afin de roder les mécanismes de gestion (notamment au plan de la circulation de l'information) et de coordination reliés à la distribution de pilules d'iode. Assurer les modalités de rétroaction de ces exercices auprès des intervenants de première ligne, soit les bénévoles.
- 8 Soutenir l'activité des bénévoles par une campagne d'information adressée au grand public afin de préparer leur intervention éventuelle auprès de la population. Encore une fois, nous devrions mettre à contribution les structures déjà établies avant de penser à en soutenir de nouvelles. Les municipalités et les institutions d'enseignement seraient des partenaires logiques dans cette activité d'éducation de masse. Cette campagne devrait prévoir une attention toute spéciale envers les médias afin d'assurer, en cas d'accident nucléaire, un minimum de correspondance entre la version médiatique et celle véhiculée par les bénévoles.
- 9 En cas de circonstances exceptionnelles caractérisées par une situation de haute instabilité, le contact avec les bénévoles devrait être constant. À défaut de pouvoir fournir un équipement de

communication personnel à chaque individu, une station de radio devrait être réquisitionnée afin d'assurer un canal de communication officiel, non seulement pour les gens impliqués dans la distribution des pilules d'iode mais aussi pour assurer la coordination générale des opérations.

Références

- Brown, S.R. Political Subjectivity: applications of Q-Methodology in political science, London, Yale University Press, 1980.
- Corriveau, R. «Doit-on intégrer le risque à nos cultures? Doit-on évoluer vers une culture du risque?», conférence prononcée au Colloque International Médias et crise, Université Laval, Octobre 1990.
- Corriveau, R. «Le rattachement idéologique: un facteur important à la cohésion en situation d'urgence», conférence prononcée au Congrès de l'Association Canadienne de communication, Queen's University, mai-juin 1991.
- Diggs, D.M. (edit). Natural Hazards Research And Applications, Risk communication, lessons from natural hazards: an annotated bibliography, Boulder, Natural Research Center, 1988.
- Fossaert, R. Les structures idéologiques, Paris, Seuil, 1983.
- Godin, G. «Les fondements psychosociaux dans l'étude des comportements reliés à la santé», Santé et Société, Québec, Gouvernement du Québec, Collection promotion de la santé, Vol. 3 (1990), pp. 5-25.
- Goldmann, L. La création culturelle dans la société moderne, Paris, Denoël/ Gonthier, 1971.
- Goldmann, L. Sciences humaines et philosophie, Paris, Gonthier, 1966.
- Gillepsis, D.F. (edit). Mapping networks of organized volunteers for natural hazard preparedness, Washington, Final report submitted to the National Science Foundation, Societal Response, Earthquake Hazards Mitigation Program, 1986.
- Mace, G. Guide d'élaboration d'un projet de recherche, Québec, PUL, 1988.
- McKeown, B. et Thomas, D. Q Methodology, Newbury Park, Sage University Paper, 1988.
- OMS. Énergie nucléaire: rejets accidentels-guide pratique des mesures de santé publique-, Mel, Belgique, Série européenne, No 21, 1985.
- Zeigler, D. et Johnson, J. «evacuation Behavior in Response to Nuclear Power Plant Accidents», Professional Geographer, 36, No 2, 1984, pp. 207-215.

**ETUDE DE L'EXPOSITION INDUSTRIELLE A DES OXYDES
D'URANIUM (UO₂ - U₃O₈)
METHODES ET RESULTATS**

**E. Ansoborlo ; P. Bérard ; J. Chalabreysse ;
M.H. Hengé-Napoli ; B. Quesne***

CEA/Institut de Protection et de Sureté Nucléaire
Département de Protection de la santé de l'Homme et de
Dosimétrie
Service d'Hygiène Industrielle.
BP 38 - 26701 Pierrelatte France

* COGEMA/Service de Médecine du Travail
BP 16 - 26700 Pierrelatte France

**OCCUPATIONAL EXPOSURE TO URANIUM OXIDES (UO₂ - U₃O₈)
METHODS AND RESULTS**

ABSTRACT

Chronic exposure to uranium compounds such as UO₂ and U₃O₈ led to the development of a methodology, based on the recommendation of ICRP, involving four main steps : the measurement of the uranium concentration and the particle size distribution at the workstation, the assessment of physico-chemical properties of the compound, the study of in-vitro solubility using a chemical test and the monitoring of workers.

Results and comments on UO₂ and U₃O₈ are given.

INTRODUCTION

Le but de cette étude est de décrire une méthodologie permettant d'évaluer les risques au poste de travail, de définir le comportement biologique des composés afin d'orienter la surveillance radiotoxicologique. Cette méthodologie appliquée aux composés UO₂ et U₃O₈ comporte quatre étapes :

- L'étude du poste de travail sur plusieurs jours, à l'aide de prélèvements individuels, en ambiance et de mesures de la distribution granulométrique afin d'évaluer le diamètre aérodynamique médian en activité ou DAMA et la déviation géométrique standard σ_g .
- La détermination des caractéristiques physico-chimiques des composés UO₂ et U₃O₈, comprenant la surface spécifique, l'identification par diffraction X et spectrométrie infra-rouge, la composition isotopique par spectrométrie de masse.
- L'étude de la solubilité chimique in-vitro à l'aide d'un test chimique décrit par Ansoborlo et Hengé-Napoli (1), permettant de déterminer la cinétique de dissolution, de calculer la périodes de chaque composé suivant la classification ICRP (2)

et de comprendre les mécanismes chimiques de dissolution. Le solvant est un liquide de culture cellulaire ou Gibco, tamponné à pH = 7,3, utilisé à 37°C sous 5 % de CO₂. Pour ces essais la poussière est présélectionnée par sédimentation à un DAMA de 3 µm.

- La surveillance du personnel avec suivi des selles, des urines, le contrôle de la charge pulmonaire par anthropogammamétrie et éventuellement des prélèvements et analyses sur mouchoir.

RESULTATS ET DISCUSSION

Les deux composés industriels étudiés UO₂ et U₃O₈ ont été prélevés sur un poste correspondant à un basculement de fut dans un container, impliquant donc une exposition du personnel, équipé en tenue spéciale avec port de masque.

Deux campagnes de prélèvement de trois jours chacune, correspondant aux deux composés UO₂ et U₃O₈ ont été réalisées, et les résultats sont présentés dans la figure 1 : la concentration en UO₂ varie entre 2,1 et 88,5 Bqm⁻³ et celle d'U₃O₈ entre 0,05 et 1,6 Bqm⁻³.

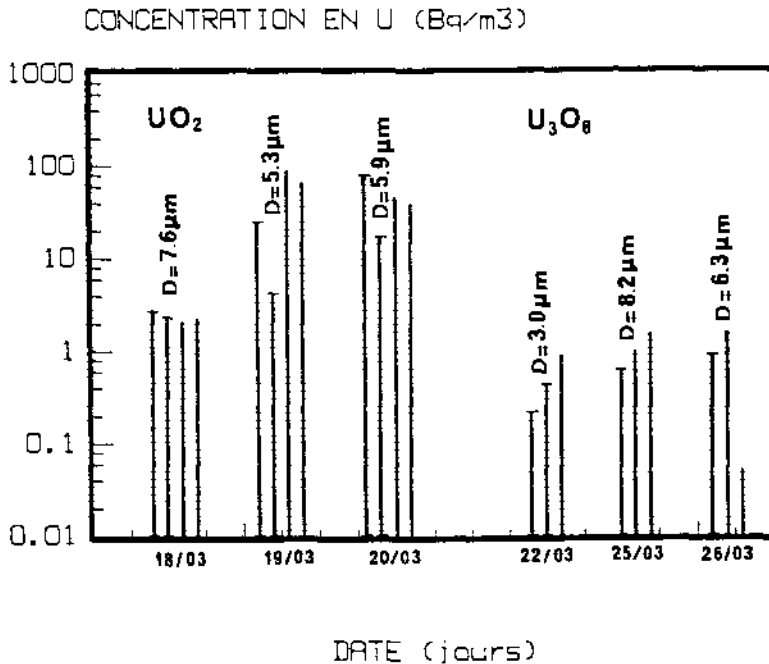

Figure 1 = Mesures de concentrations en Uranium et de diamètre aérodynamique sur un poste de travail - Composés manipulés UO₂ et U₃O₈.

Les concentrations en UO₂ sont supérieures à celles obtenues avec U₃O₈ d'un facteur 40. La mesure des DAMA varie de 5,3 µm

à 7,6 μm avec σg compris entre 2,1 et 2,5 pour UO_2 et de 3 μm à 8,2 μm avec σg compris entre 2,76 et >4 pour U_3O_8 . Les σg supérieures à 2 traduisent des distributions hétérogènes et le calcul du DAMA moyen sur les 6 prélèvements soit $6,1 \pm 1,6$ μm , permet d'estimer, suivant le modèle ICRP (2), que 78 % des particules inhalées seront déposées au niveau du naso-pharynx.

L'étude des caractéristiques physico-chimiques à l'aide de spectres de Rayon X et d'infra-rouge solide a permis d'identifier les 2 composés UO_2 et U_3O_8 sans trace d'impuretés. Leur composition isotopique correspond à celle de l'uranium naturel. La mesure des surfaces spécifiques a donné $4,3 \text{ m}^2\text{g}^{-1}$ pour UO_2 et $5,9 \text{ m}^2\text{g}^{-1}$ pour U_3O_8 , surfaces relativement faibles.

La figure 2 représente les résultats obtenus lors des essais de solubilité chimique en milieu Gibco. Notons une solubilisation toujours importante le premier jour correspondant à une phase rapide de dissolution, suivie d'une deuxième phase beaucoup plus lente ; l' U_3O_8 se dissout à raison de 7,5 % en 1 jour et 92,5 % en 51,8 jours, et l' UO_2 à raison de 7,4 % en 1 jour et 92,6 % en 212 jours. Si la phase rapide est identique, la deuxième phase est très différente et implique une classification de type W pour U_3O_8 et de type Y pour UO_2 .

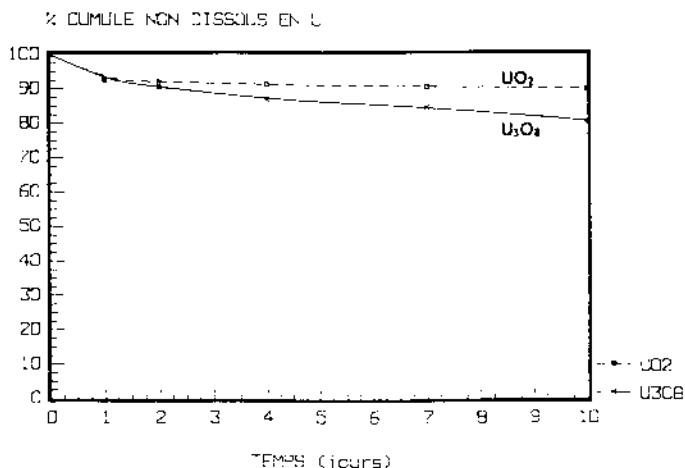

Figure n° 2 : cinétique de dissolution des composés UO_2 et U_3O_8 en milieu de culture cellulaire Gibco.

La classification ainsi déterminée in-vitro et la valeur moyenne de 6 μm pour le DAMA, permettent de calculer à partir du modèle ICRP des limites de concentrations admissibles dans l'air ou LDCA, propres à chacun des composés étudiés : ainsi pour U_3O_8 (92,5 % classe W) la LDCA calculée en uranium naturel est de $36 \text{ Bq}\mu\text{m}^{-3}$ et pour UO_2 (92,6 % Classe Y) la LDCA est de $2 \text{ Bq}\mu\text{m}^{-3}$.

Dans ces conditions nous pouvons considérer sur la figure I que l'exposition à U_3O_8 donne des valeurs inférieures à la LDCA de

36 Bqm⁻³, alors que pour UO₂ la LDCA de 2 Bqm⁻³ est dépassée. Les résultats d'analyses urinaires, sur mouchoirs et en anthropogammamétrie sur une période de 2 mois et qui ne correspondent pas uniquement à l'exposition des deux composés étudiés, sont inférieurs aux valeurs limites de détection, soit : (5 à 6 mBq.g⁻¹ de créatinine) pour les urines, 40 mBq pour les mouchoirs et 150 Bq pour l'anthropogammamétrie. Toutefois, il est intéressant de noter que la valeur moyenne obtenue par analyse des selles (12 personnes), durant la même période est de 357 mBq par 24 h pour des valeurs très dispersées allant de 20 à 850 mBq par 24 h (la valeur moyenne d'une population non exposée est de 20 à 70 mBq par 24h). Ce résultat est très difficile à corrélérer avec l'exposition observée, dans la mesure où il ne correspond pas à une exposition unique, mais à une exposition sur 2 mois à différents postes et sur différents composés allant de l'uranium naturel à l'uranium de retraitement.

CONCLUSION

La méthodologie d'étude d'un poste de travail décrite pour deux composés UO₂ et U₃O₈ met en évidence l'importance de la connaissance de deux paramètres essentiels, à savoir le DAMA et la classe de transférabilité, d'une part pour calculer une LDCA propre à chaque composé et d'autre part pour orienter la surveillance radiotoxicologique.

Les variations importantes de concentrations mesurées au poste de travail semblent liés au mode de travail des personnes : l'expérience montre que des équipes postées, travaillant sur un même produit, entraînent des valeurs très différentes de concentration dans l'air. La corrélation difficile entre les valeurs de concentration mesurées et les résultats de mesure dans les excréta ou par anthropogammamétrie, vient du fait que les travailleurs sont équipés de protections efficaces et qu'ils changent souvent de poste et de composé.

Ces observations mettent donc en évidence l'intérêt de la connaissance de tous les postes et composés utilisés dans un même atelier afin de bien orienter la surveillance radiotoxicologique.

Cette étude a permis, à partir de résultats au poste de travail, de calculer des LDCA de 36 Bqm⁻³ pour U₃O₈ et de 2 Bqm⁻³ pour UO₂.

BIBLIOGRAPHIE

- (1) ANSOBORLO, E., HENGE-NAPOLI, M.H., 1990, In vitro chemical and cellular test applied to uranium trioxide with different hydration states. Eulep International Symposium, Oxford UK 19-21 september 1990.
- (2) ICRP 1979, International Commission on Radiological Protection. Publication 30 - Limits for intake of radionuclides by workers - part 1 and 4 (Pergamon Press, Oxford)

**INTERNAL EXPOSURE IN FRENCH NUCLEAR POWER PLANTS :
10 YEARS ON**

C. CHEVALIER - M. GONIN

Laboratoire d'Analyses de Biologie Médicale et de Radiotoxicologie -
Service Général de Médecine du Travail - EDF, Saint-Denis, FRANCE

ABSTRACT

Collectively speaking, internal exposure in French nuclear power plants is negligible. However, some quite high individual doses have been recorded.

The details of cases of significant contamination are presented here in table form. A brief discussion of a few particular cases underscores the problems involved.

INTRODUCTION

At Electricité de France (EDF), individual monitoring of internal exposure is carried out by the occupational health services in the power plants. These services are equipped with counters for thoraco-abdominal activity. The radiotoxicological laboratory analyses all the biological samples (urine, faeces, nose-blows) and centralises the results.

Data from ICRP publications n°s 30 and 54 are used for the dose calculations.

The monitoring primarily concerns EDF workers. However, the analyses necessary for estimating internal exposure are also carried out for persons from other companies required to work on-site. Currently, the medical services monitor a total of about 30,000 people per year.

RESULTS AND DISCUSSION

1 - COLLECTIVE DOSES

Column 1 of the table shows that the collective effective dose equivalents are extremely low : 0.16 man-Sv over 10 years. Compared with those resulting from external exposure (which will be the subject of other papers), they are negligible.

French power plants are therefore, in general, "clean" and the protection methods used are efficient.

2 - INDIVIDUAL DOSES

The second part of the table (columns 2) shows the distribution of the effective dose equivalents among the different persons, and the major radionuclides measured. The table takes into account only those persons from whom, in addition to body counting, biological samples were taken.

TABLE : INTERNAL EXPOSURE (EDF + OTHER ON-SITE WORKERS)

YEAR	1	2		
	COLLECTIVE DOSE man-mSv	NUMBER OF WORKERS (EDF AND OTHER ON-SITE WORKERS)		
		HE = 0	0.5 ≤ HE < 5 mSv	5 ≤ HE < 50 mSv
1981	0	130		
1982	0	142		
1983	11	115	1 (I-131)	1 (α)
1984	72	80	1 (I-131)	1 (Ce-144 + α) 1 (Co-60)
1985	3	135	2 (Co-60 + α)	
1986	3	201	1 (Co-60)	
1987	6	121	2 (H-3) 1 (α)	
1988	28	108	2 (Ag-110m) 1 (α)	2 (α)
1989	1	187	2 (α)	
1990	39	197	5 (Co-60 + α) 5 (Co-60) 1 (α)	2 (Co-60 + α) 1 (α)
TOTAL	163	1416	24	8

α : transuranium isotopes

1 - Collective committed effective dose equivalent. (Only dose equivalents higher than 0.5 mSv are recorded).

2 - Number of workers (for whom doses have been estimated), per level of effective dose equivalent (HE). Dominant radionuclide(s) shown in brackets.

2-1 NUMBER OF SIGNIFICANT EXPOSURES

The total number of significant exposures (ie higher than the 0.5 mSv recording level adopted at EDF) is very low : 32 cases in all. Of these only 8 had an effective dose higher than 5 mSv. For these few persons, the doses are not always negligible. Furthermore, adding effective doses to external exposures doses can lead to regulatory limits being exceeded.

2-2 PRINCIPAL RADIONUCLIDES

The most frequently detected radionuclides in retention measurement are Co-58 and Co-60. However, other γ emitters can be dominant in the dose calculations : I-131, Ce-144 and, more recently, Ag-110m.

As far as other types of emitter are concerned, tritium is not a problem (the two cases recorded in 1987 are unrepresentative because the contamination occurred at Brennilis, a heavy-water power plant). However, the same cannot be said for the α emitters. In about half the cases, the transuranium isotopes were very dominant in the dose calculation. But the only test which allows them to be quantified with sufficient sensitivity is faecal analysis. Samples of the faeces must be taken, and specific tests - designed to detect α emitters at very low activity levels - carried out on them.

We were unable to find γ emitters which could consistently indicate the presence of these α emitters. Ce-144 and Cs-137 gave the best results, but Ce-144 is difficult to detect in retention measurements, and Cs-137's presence in the organism can be totally masked by that of Ag-110m.

Two cases of contamination illustrate this :

- the first case occurred in 1984. The mixture inhaled contained a number of radionuclides including Ag-110m. The presence of Cs-137 was detected in the urine, the presence of Ce-144 in the faeces. The contribution of the α emitters to the effective dose was greater than 95 %, the Ce-144 accounting for virtually all the rest. The estimated dose was close to 50 mSv.

- an even more striking case occurred in 1988. The only radioelement detected by retention measurement was Cs-137 (activity : 3 kBq). According to data from ICRP n° 54, the presence of α emitters in the faeces corresponded to an effective dose of about 20 mSv.

2-3 DIAMETER OF THE INHALED PARTICLES

A third case of contamination, which also occurred in 1984, suggests that the question of the diameter of inhaled particles needs to be looked into as well. In power plants, particles may have a diameter such that they are deposited in the naso-pharynx region and later swallowed. When this happens, and it is not uncommon, it represents the equivalent of an oral intake. The activity measured must be compared to the oral ALI.

This was the case in 1984 when a particle containing 22 MBq of

Co-60 was inhaled. The activity was such that retention measurement was impossible. Once the particle had been eliminated in the faeces, a comparison was made with the oral ALI (for a factor $f_1 = 5\%$). This comparison showed that the regulatory limit had in theory been exceeded. In reality, comparing urinary and faecal activity allowed the f_1 factor to be estimated at a value in the region of 10^{-4} . More importantly, a gentle laxative was used to accelerate passage through the intestine, thus diminishing exposure time. The particle was eliminated in 23 hours instead of the 42 hours forecast by the gastro-intestinal tract model. Taking these factors into account, the estimated effective dose was not higher than 25 mSv.

This case of contamination raises a double problem: first of all, the limits of the ALI concept for estimating doses and, more importantly, the problem of "hot" particles. It shows in effect that the inhalation of very active particles can lead to rather high effective doses even when they are later swallowed. From the medical point of view, given the size of these particles, it is to be hoped that they cannot penetrate the trachea, because that would then raise the delicate problem of their extraction.

CONCLUSION

Internal exposure does not represent a problem on the collective level in power plants. However, it can correspond to non-negligible individual doses.

The few examples cited show that :

- transuranium isotopes must be tested for,
- in making dose estimations - calculated from measurement results - the subject's metabolic variations, and the physico-chemical characteristics of the inhaled particles, must be taken into account. In other words, it is necessary to go beyond the ALI concept,
- finally, the existence of "hot" particles points up the eventual need for a therapeutic intervention, were such particles to penetrate the respiratory system. This requires further study.

The first two points implicitly raise questions, not dealt with here, of the reliability of measurement results and the validity of their interpretation in dose terms.

Intercomparison exercises between laboratories are needed to check measurement reliability, particularly in the case of very low transuranium isotope activity. This type of exercise is organised in some countries. In France, for example, the CEA (Commissariat à l'Énergie Atomique) organises voluntary intercomparison exercises among a number of European laboratories.

International intercomparison exercises, less confidential than those which currently exist, are needed to check the reliability of dose estimations. Such exercises will allow specialists from the different countries involved to standardise the procedures used.

ASSESSMENT OF INTAKES AND RADIATION DOSES FOLLOWING EXPOSURE TO TRITIATED WATER

Kamala Rudran, J.V. Sawant, S. Thampan and V.S. Bangera

Health Physics Division
Bhabha Atomic Research Centre
Trombay, Bombay - 400 085
I N D I A

ABSTRACT

Biological half-lives, (T_b) of tritium following exposure to tritiated water (HTO) are reported. T_b varied from 2.5 to 16 days with an average of 6.8 days. Equilibrium conditions existing between HTO concentrations in blood and urine at the time of voiding is demonstrated. T_b is observed to be affected only marginally by age or body weight and significantly by ambient conditions like temperature and moisture content of the air.

INTRODUCTION

Biological half-life is an important parameter in assessment of intakes. ICRP has adopted T_b of 10 days for HTO component for the purpose of internal dosimetry. Second component arising from the intake of HTO in human has been reported by a few authors, as quoted by Rudran [1988], who concludes that CEDE from the second component is about 1.5 to 2.5 times CEDE due to HTO alone. This has not been given due weightage assuming this to be less than 10% of the total (ICRP, 1979). Observations by the authors in the dose evaluation studies following intake of HTO under occupational conditions in 86 cases are reported here. Study of 40 cases of reported earlier (Thampan et al. 1974).

METHODOLOGY

Intake of HTO in heavy water moderated cooled research reactor CIRUS (40 Mw) is negligible under normal working conditions. Following spillage of heavy water and clean up operations urine analysis of concerned persons is carried out. Follow up studies are conducted whenever the first urine samples collected exceeds concentration of 370 KBq l^{-1} . The results are evaluated for T_b , intake and radiation dose. Blood samples are collected from exposed individuals in the morning after overnight urine collection. Tritium as HTO in the blood sample is corrected for HTO at the midpoint of urine collection with T_b of 7 days. At times, ^3H excretion in urine is followed for longer periods. These studies lead to the observation and evaluation of a second component (Rudran 1988). T_b observed in late winter during the month of Feb.-March were separated out and variations of T_b with age and body weight were studied by least square analysis. From the known temperature and humidity conditions existing in Bombay at different periods of the year, moisture content of air (g/m^3) was calculated.

Variation of Tb_1 with temperature and water content in the air at the mid-point of study period was worked out.

RESULTS

Concentration of 3H as HTO in blood and urine are given in table 1 and show that HTO is at equilibrium concentration in urine and blood at the time of voiding.

A study of 86 cases, showed Tb_1 varying from 2.5 days to 16 days. The results are presented in fig. 1. The average is 6.8 days. Thus under climatic conditions around Bombay, 7 days Tb_1 is appropriate for dosimetry.

Variation of Tb_1 w.r.t. atmospheric temperature are shown in table 2 and w.r.t. humidity conditions fig.2. The figures show an inverse relationship for Tb_1 with atmospheric water content. Tb_1 doesn't show any relationship directly attributable to ambient temperature.

26 case studies were made in late winter during Feb.-March under similar climatic conditions. These were analysed for variations due to individual parameters namely age and body weight. Results are shown in figures 3 & 4. The regression lines show that variations attributable to age or body weight are minimal.

Intake and CEDE to exposed individuals were evaluated using standard techniques (Thampan et. al. 1974, Rudran and Kirthi 1984) highest value of CEDE was 9.6 mSv when HTO component alone was taken care of. When contribution from second component is accounted for, CEDE is 25 mSv, 2.5 times that due to HTO (Rudran, 1988) and is within the annual permissible limit.

CONCLUSION

A Tb_1 of 7 days is appropriate for dose calculation from HTO intakes under tropical conditions prevalent in India. Changes in Tb_1 by a factor of 2 to 3 from the average are likely, due to ambient conditions. There is no significant change in Tb_1 due to age or body weight for the occupational group, normally 20 to 60 years and body weight group of 40 to 80 Kg.

REFERENCES :

1. ICRP (1979) Metabolic Model for Hydrogen, p. 65-68, Limits for Intakes of Radionuclides by Workers, ICRP Publication 30, Part 1.
2. ICRP (1990) Annual Limits on Intake of Radionuclides by Workers, ALI Based on the 1990 Recommendation, p. 5. ICRP Publication 61.
3. Kamala Rudran and Kirthi K.N. (1984) Derived Investigation Levels for the Purpose of Internal Dosimetry for Tritium, Bulletin of Radiation Protection 7, 4, 61-68.

4. Rudran K. 1988. Significance of in-vivo Organic Binding of Tritium following Intake of Tritiated Water, Radiation Protection Dosimetry, 25, 5-13.
5. Thampan S., Pullat V.R. and Kamala Rudran (1974) Dose Evaluation following Accidental Intakes of Tritiated Water in a Heavy Water Moderated Reactor, Abstract No. 3, 101, p. 61, Paper presented at the First Asian Regional Congress on Radiation Protection, IRPA, Abstracts Published by IARP, BARC Bombay.

ACKNOWLEDGMENT : The work reported is part of the research and development programme of Health, Safety and Environment Group, BARC.

Table - 1

Urinary HTO and HTO in blood at the time of voiding,

Case No.	Concentration KBq/l of Tritium	
	Urine	Blood
1.	960 ± 26	930 ± 10
2.	84 ± 2.6	84 ± 2.5
3.	340 ± 10	330 ± 10

Table - 2

Variation of T_{b1} of tritiated water with ambient temperature

No. of experiments	Ambient Temperature °C During the Study period			Average T _b days
	Maximum	Minimum	Average	
9	29	20	24.5	7.5
20	30	21	25.5	7.3
9	33	26.4	29.7	5.9
10	30	25	27.5	5.1
6	32	23	27.5	6.4
6	33	27	30	6.9

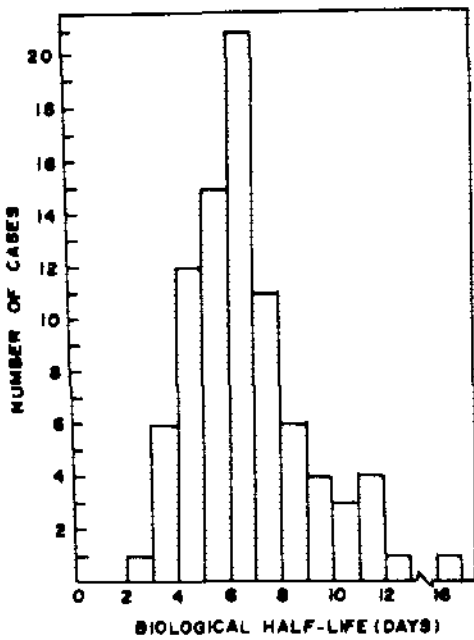

Fig. 1. Incidence of T_{b1} of Tritium (HTO)

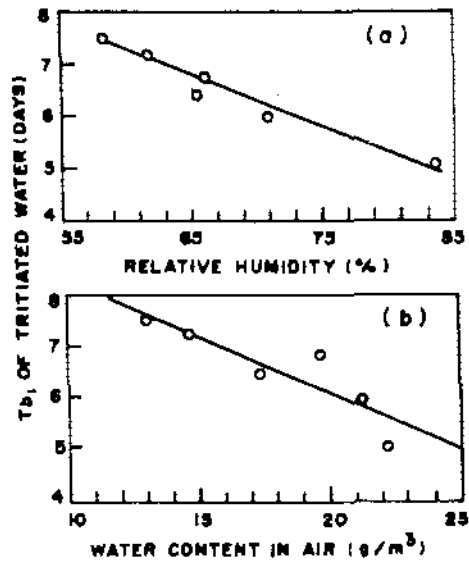

Fig. 2. Biological half-life of tritiated water vs humidity conditions.

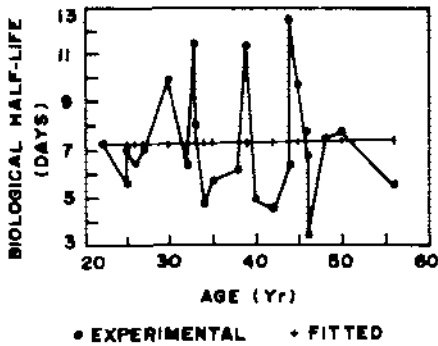

Fig. 3. Biological half-life vs age.
(FEB - MAR)

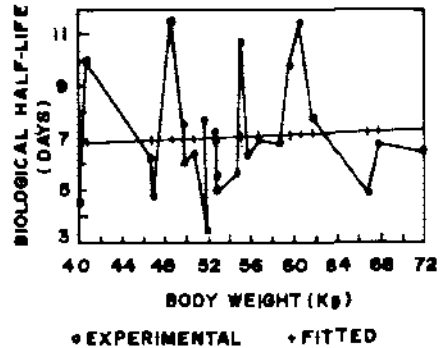

Fig. 4. Biological half-life vs body weight.
(FEB - MAR)

EXPOSURE TO RADIOACTIVE AEROSOLS IN MINING AND MILLING
OPERATIONS; THE IMPORTANCE OF ^{227}Ac AND ^{231}Pa

R. Vicente; J.C. Dellamano; S.A. Bellintani

INSTITUTO DE PESQUISAS ENERGÉTICAS E NUCLEARES
IPEN-CNEN/SP

FAX: 55 11 2123546 C.P.11049 CEP:05499

SÃO PAULO - BRASIL

^{227}Ac (half-life of 21.8 y) is the daughter of ^{231}Pa ; a beta-emitter and parent of a subseries with five short-lived alpha-emitters. ^{231}Pa (half-life of 3.27×10^4 y) is an alpha-emitter of the actinium series, the decay chain of ^{235}U . As daughters of this uranium isotope they are thought to be unimportant as a radiological hazard, despite the fact that their ALI values for ingestion and inhalation are the lowest of any other radionuclide. Both nuclides can be considered as being in secular equilibrium with uranium in most geological media and so the mass concentration of ^{231}Pa is the same of the ^{226}Ra and that of ^{227}Ac is the same of the ^{210}Po , to mention only two radionuclides of radiological concern. It is shown in this paper that if ^{231}Pa and ^{227}Ac are considered in the evaluations of dose commitments incurred by inhalation of aerosols in mining and milling operations, the results can be 70% higher than those calculated by the methodology of ICRP Publication 47.

ANNUAL DOSE DISTRIBUTIONS FOR THE
OLYMPIC DAM OPERATIONS

Jim Hondros
Olympic Dam Operations
Box 150, Roxby Downs
South Australia 5725

ABSTRACT

Production of uranium and copper from the Olympic Dam Operations' underground mine and metallurgical processing plant commenced in 1988, with underground exploration and development commencing in 1983. Since commencement of operations, employee radiation doses have been monitored and assessed to ensure that they remain well controlled. Total radiation doses to employees are calculated using the standard dose assessment methodology of the ICRP. Dose assessments to date indicate that all employee doses are well controlled.

INTRODUCTION

Olympic Dam Operations is a copper, uranium, gold and silver producer located approximately 600 kilometres north of Adelaide in South Australia. Ore is extracted from the underground mine workings at a depth of approximately 500 metres and is processed in a multifunction metallurgical plant. The ore body was discovered in 1975 and underground exploratory and development work commenced in 1983 when a shaft access was sunk. Following construction of a service decline in 1988, full scale production commenced using the open stoping mining method. The underground operation is highly mechanised and produces 1.6 million tonnes of ore per year. This is set to increase to 2.2 million tonnes at the beginning of 1992.

The ore is treated in the metallurgical plant situated 2 kilometres west of the main shaft and service decline. The plant commenced production in the second half of 1988. The ore is crushed, ground and treated with a flotation agent which results in initial separation of the uranium bearing minerals and the copper sulphide bearing minerals. The uranium minerals are processed to produce uranium oxide using standard solvent extraction techniques. The copper sulphides are dried and treated in a flash smelter to produce blister copper. Electrorefining further purifies the copper. Gold and silver is present in the residue of the electrorefining process. Approximately 48,000 tonnes of refined copper and 1600 tonnes of uranium oxide is produced annually.

At present there are approximately 800 people employed to operate, maintain and manage the operations.

Since commencement of underground operations in 1983, employee radiation doses have been monitored and assessed to ensure that they remain well controlled.

DOSE ASSESSMENT METHODOLOGY

In the mining and processing of radioactive ores, there are three major pathways by which employees can be exposed to radiation. These are;

- irradiation by gamma radiation,
- inhalation of radon daughters,
- inhalation of radioactive dust.

Assessing employee dose relies upon monitoring each exposure pathway to determine worker exposure, then applying an ICRP-based exposure-to-dose conversion factor.

Employee exposures are assessed using the results of a government approved radiation monitoring programme. At the mine, radon daughter levels are measured in all workplaces at least twice per week. Personal dust levels are measured twice weekly for all occupation groups. Gamma radiation levels at all locations are measured routinely, however, employee exposures are assessed using personal thermoluminescent dosimeters (TLD badges). In the metallurgical plant, personal dust samples measure the exposure to dust and TLD badges measure exposure to gamma radiation. The nature of the metallurgical plant means that employees will be exposed to dusts containing different quantities and ratios of radionuclides. This requires routine radionuclide analysis of dust samples. For the mine and metallurgical plant, workplace and occupation based concentration levels are then combined with occupancy time information to derive employee exposures.

The dose assessment methodology is based on the additivity principle of the ICRP. That is, the effective dose from each of the radiation exposure pathways are added together and compared to the annual dose limit. Experience at Olympic Dam indicates that on average, of the total dose received by the underground workers, one third is due to each of the major radiation exposure pathways. For the metallurgical plant, on average, approximately 85 percent of the total dose is derived from the inhalation of radioactive dust and 15 percent from gamma radiation.

ICRP32¹ provides a dose conversion factor of 10 milliSieverts per working level month (mSv/WLM) which is used for the conversion of radon daughter exposure to radon daughter dose. Conversion of employee dust exposure in Becquerel hours per cubic metre (Bq.h/m³) to an effective dose equivalent is more complex and requires the use of ICRP30². Dose conversion factors for radioactive dust are a function of a number of different parameters including dust activity distribution and relative radionuclide content of the dust. TLD badges report a whole body dose and do not require a dose conversion factor.

DOSE STATISTICS

The most recent distribution of doses for the mine and the metallurgical plant employees can be seen in figures 1 and 2 for the period 1/7/90 to 30/6/91.

**ANNUAL DOSE DISTRIBUTION 1990/91
MINE EMPLOYEES**

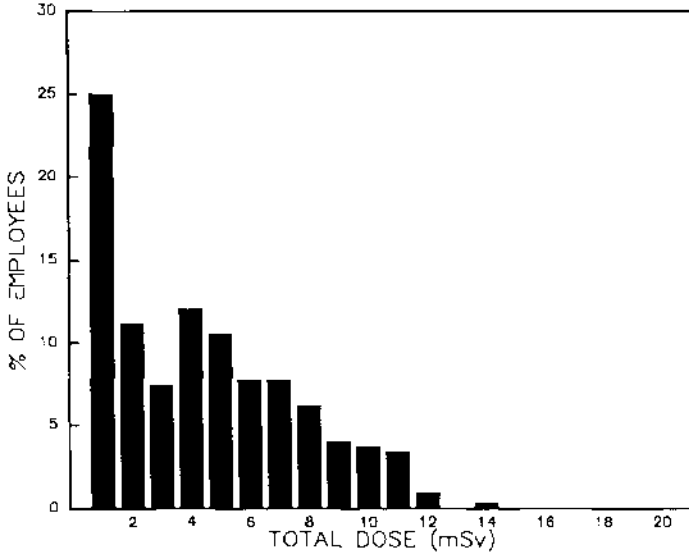

Figure 1: Mine employees dose distribution

**ANNUAL DOSE DISTRIBUTION 1990/91
PLANT EMPLOYEES**

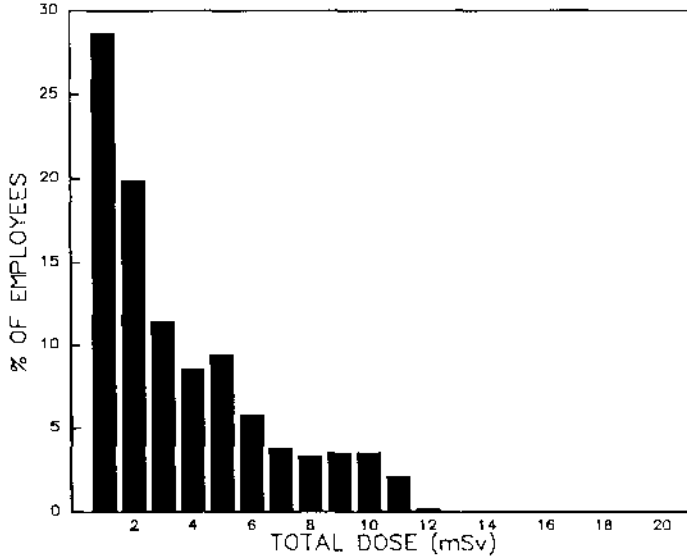

Figure 2: Plant employees dose distribution

The current dose limit recommended by ICRP is 20 mSv per year, averaged over five years ICRP60³, with a maximum annual limit of 50 mSv. Dose statistics for the years since commencement of full scale production can be seen in Table 1.

FINANCIAL YEAR	MINE		PLANT	
	AVERAGE	90th PERCENTILE	AVERAGE	90th PERCENTILE
1988/89	5.7	15.0	5.0	10.4
1989/90	4.0	11.0	3.6	6.8
1990/91	3.9	8.6	3.1	7.7

Table 1: Olympic Dam Operations Dose Statistics Since Commencement Of Production (all units are mSv)

CONCLUSION

The dose assessments presented in this paper demonstrate that the existing radiation protection mechanisms are adequate for the control of employee exposure, even considering the new ICRP dose limit. Olympic Dam Operations recognises that it is most important to continue to be vigilant and pursue the lowering of employee doses.

REFERENCES

1. ICRP32 Limits for inhalation of Radon Daughters by Workers. International Commission on Radiological Publication 31, 1981.
2. ICRP30 Limits for Intakes of Radionuclides by workers. International Commission on Radiological Protection Publication 30, 1979.
3. ICRP60 1990 Recommendations of the International Commission on Radiological Protection. Publication 60.

ACKNOWLEDGEMENT

The author would like to thank the Olympic Dam Joint Venture Management Committee for permission to publish this paper.

IAEA - USSR WHOLE BODY COUNTER INTERCOMPARISON

R.V. Griffith and R. Ouvrard
International Atomic Energy Agency
P.O. Box 100, A-1400 Vienna, Austria

V. Bad'in
Institute of Biophysics
USSR Ministry of Health, Moscow

S. Ulanovsky
Byelorussian Ministry of Public Health, Minsk

A. Kovtun
Research Institute of Sea Transport Hygiene, Leningrad

I.A. Likhtarev, L.A. Litvinets, V.S. Ropin, O.N. Perevoznikov
and V.A. Parrhomenko
Ukrainian Research Centre for Radiation Medicine, Kiev

F. Steger
Austrian Research Centre, Seibersdorf

ABSTRACT

As part of the IAEA programme to corroborate measurements of internal contamination levels ^{137}Cs in the effected population made by Soviet specialists following the 1986 accident at Chernobyl, the Agency has coordinated an intercomparison programme involving measurements at 8 Soviet whole body counting facilities. Additional measurements were made in the mobile van loaned to the Agency for use in the Soviet Union whole body counting programme by SCPRI, France; and whole body counters in Seibersdorf, Austria operated by the IAEA and the Austrian Research Centre.

INTRODUCTION

During a mission to the Soviet Union in August 1990 it was concluded that an intercomparison of USSR, IAEA and of the Austrian whole body counters used for *in vivo* measurement of ^{137}Cs would be valuable in corroborating large scale measurements of the USSR population.

The IAEA obtained use of a standard, adult phantom from the Battelle Pacific Northwest Laboratories in the United States. The phantom is a "Bush" or "Bottle" type, filled with solid, polyurethane tissue substitute and labelled uniformly with ^{137}Cs . The total quantity at the time of the intercomparison was 11,170 Bq (0.3 μCi). A solid matrix was necessary to avoid the practical problems of handling radioactive liquids during transport. Although accurate measurement of the caesium level in children is a major concern, it was not possible to locate a standard child phantom with a solid matrix.

INTERCOMPARISON SEQUENCE

Counting was performed in the SCPRI counting van, with the IAEA chair counter and with a whole body counter of the Austrian Research Centre during the week starting 17 September 1990. The phantom was then taken to the USSR and used there in various institutes. The intercomparison programme was completed in December 1990 with a final counting of two USSR phantom systems at Seibersdorf. The USSR institutes that participated in the intercomparison programme and the counter characteristics are listed in Table 1.

Table 1 - Counter characteristics of the participants in the IAEA whole body counting intercomparison programme				
Institute	Location	Counter type	Detector	¹³⁷ Cs background rate (counts/s)
Institute of Biophysics	Moscow	Stool, CIB-2	Ge. 100 cm ³	1.2
		Chair, CIB-1	NaI, 350 cm ³	
Ministry of Public Health	Minsk	Stool, QBM-1	NE 110, 5100 cm ³	24.8
		Chair, CIB-1	NaI, 1770 cm ³	4.9
		Chair, CIB-1	NaI, 200 cm ³	3.2
	Krasnopolje	Stool	NaI, 1310 cm ³	
Research Institute of Sea Transport Hygiene	Leningrad	Chair	NaI, 200 cm ³	1.8
Institute of Radiation Hygiene	Novozybkov	Chair, CIB-1	NaI, 200 cm ³	1.7
All Union Centre of Radiation Medicine	Kiev	Stool	NaI, 2060 cm ³	8.6
Ministry of Public Health	Kiev	Chair	NaI, 200 cm ³	5.1

USSR PHANTOM COUNTING, SEIBERSDORF

At the invitation of the IAEA, two USSR phantoms were brought for counting to Seibersdorf in December 1990; 1) a polyethylene block phantom with inertable ¹³⁷Cs loaded rods from the Leningrad Research Institute of Sea Transport Hygiene and 2) a flexible plastic manikin filled with dried cesium rich green peas grown in the Chernobyl region, provided by the All-Union Scientific Centre of Radiation Medicine. Equivalent configurations from both phantom systems were counted, representing (a) a small child, (b) a child of about age 10, and (c) a small adult. In addition, samples of the dried peas used in the Kiev phantom were assayed. Counting was done both in the IAEA chair counter and the counter of the Austrian Research Centre. It must be noted that the IAEA counter is intended only for adults, and it is not specifically calibrated for children. The Austrian Research Centre also normally only counts adults. Therefore, the results of the measurements made using the child phantoms should be viewed accordingly.

RESULTS

The results of the phantom intercomparison measurements are presented in Table 2. Under the conditions of the intercomparison, it was agreed that the results from the USSR counters would not be specifically identified. Therefore, the participating institutes in the USSR are indicated only by numbers in Table 2. However, each USSR facility has been provided a tabulation of the intercomparison results together with specific identification of its own data.

CONCLUSIONS

The IAEA does not have specific criteria for the acceptability of the performance of whole body counters. However, the quality of the intercomparison results can be compared with guidance provided in IAEA Safety Series No.84, *Basic Principles for Occupational Radiation Monitoring*, paragraph 4.1.5 [1], where it is stated that:

"In the case of routine individual monitoring for external radiation relative uncertainties of -50% and +100% at the 95% confidence level are acceptable for annual dose equivalents in the range of one-fifth of the derived limit. If, however, values are of the order of the annual limits, the relative uncertainties should not exceed -33% and +50% at the 95% confidence level." ...

"Similar requirements should, in principle, also apply in the case of routine individual monitoring for internal contamination, but in practice uncertainties as small as 50% are rarely possible."

In 5 of 36 measurements reported from institutes in the USSR (Table 2), the results were outside of a range of $\pm 30\%$ compared with the reference values. One result was slightly more than 50% above the reference value. In the latter case, the measurement was made with an unshielded probe used with the phantom doubled over in the "Marinelli" position.

Based on the distribution of the intercomparison results, it can reasonably be concluded that the participating institutes are capable of performing internal caesium measurements within an accuracy that is acceptable and adequate for radiation-protection purposes.

It should also be noted that 4 out of the 5 instances of results outside the range of $\pm 30\%$ from the reference value occurred with phantoms representing children. Although the differences are not excessive, they do suggest the need for additional attention to the calibration of counters for measurements of children.

REFERENCES

1. IAEA, 1987, *Basic Principles for Occupational Radiation Monitoring*, Safety Series No. 84, IAEA, Vienna.

ACKNOWLEDGEMENT

The authors would like to thank the U.S. Department of Energy and the Battelle Pacific Northwest Laboratories for providing the bottle phantom used in this study. Appreciation goes to the Byelorussian Ministry of Health for the logistics support provided during the period of measurements in Byelorussia and the Ukraine.

Reporting institute and/or type of counter	Measured activity (Bq/kg)						
	Bottle phantom	Block phantom			Dried pea phantom		
	Adult 74 kg	Infant 10.8 kg	Child 24.3 kg	Adult 63 kg	Infant 15.5 kg	Child 27.7 kg	Adult 58.4 kg
USSR 1 ^a	148						
USSR 2	138						
USSR 3	190						
USSR 4	132	3420	3500	3120			
USSR 5	165	3390	3390	3330			
USSR 6	120	3900	3910	2840			
USSR 7	160	4210	4350	3900			
USSR 8	165						
USSR 9	90	4110	3340	3520			
USSR 10		4800		2640			
USSR 11		4450		2520			
USSR 12	172	3090	3060	3380			
USSR 13	109	3220	3340	2960			
Van 1 ^b	160						
Van 2	148						
Van 3	152						
Van 4	136						
IAEA ^c	120	2150	2360	2190	477	507	485
ARC ^d	130	3850	3810	3270	684	610	673
Ref. value	151	3190 ^e	3190 ^f	3190 ^f	570 ^g , 587 ^g , 574 ^g		

^a Institutes in the USSR are designated only by number.
^b Counter number in mobile van.
^c Chair counter at IAEA Laboratory, Seibersdorf.
^d Chair counter at Austrian Research Centre, Seibersdorf.
^e USSR value.
^f IAEA value
^g Austrian Research Centre value.

IRPA8

**Association internationale
de radioprotection**

**International Radiation
Protection Association**



ACTES DU CONGRÈS / PROCEEDINGS

Volume II

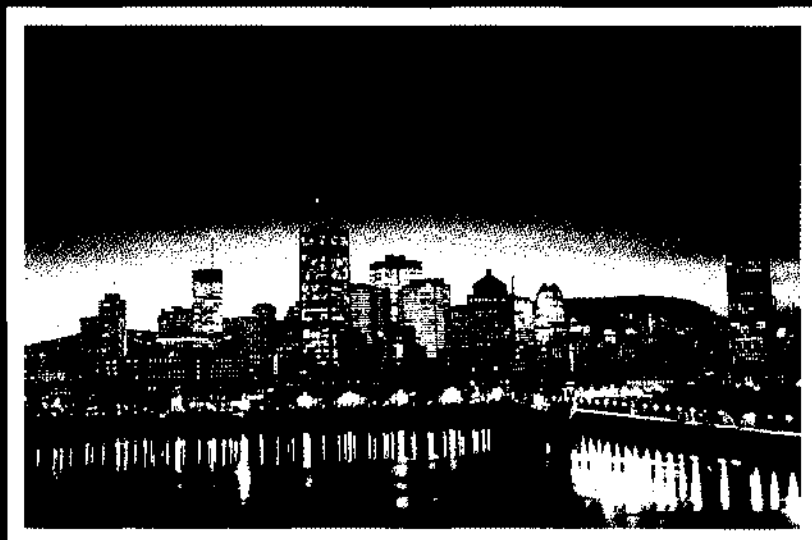

MONTREAL 92-05-17 AU/TO 92-05-22

PALAIS DES CONGRÈS

REVIEW OF THE EVIDENCE FOR CANCER PROMOTION
FROM EXPOSURE TO 50/60 Hz MAGNETIC FIELDS

Michael H Repacholi

Visiting Scientist,
Australian Radiation Laboratory, Melbourne

Chairman
International Non-Ionizing Radiation Committee of IRPA

ABSTRACT

There is some evidence from epidemiological studies that exposure of children and adults to 50/60 Hz magnetic fields may be associated with an increased incidence of leukaemia, brain tumours and other cancers. Laboratory studies have demonstrated that 50/60 Hz field exposure of biological systems is not an initiator (damages the DNA of cells) of cancer. This finding is in agreement with the fact that the photon energy of 50/60 Hz fields is much too low to break even the weakest macromolecular bonds. Thus, if 50/60 Hz fields are truly associated with an increased incidence of cancer, then these fields must act as a promoter or co-promoter of cancer in cells that have already been initiated. This paper reviews the evidence produced by the laboratory studies

INTRODUCTION

A cancer or malignant neoplasm is an apparently autonomous new growth of tissue having the ability to invade surrounding tissue and, in most cases, metastasize from the original site to distant sites where metastatic neoplasms may become established. As shown in figure 1, normal cells can undergo a process of initiation, promotion and progression that leads to the formation of a malignant neoplasm. Initiation describes changes in cells that have been exposed to a carcinogen that causes damage to the DNA. The initiating agent must be at sufficient levels to be carcinogenic. An initiated cell is not a cancer cell since the mutation in the DNA is not expressed. No detectable change in DNA synthesis or cell division or any change in enzyme activity occurs. The initiated cell remains dormant awaiting a promoting stimulus before a tumour results.

Cancer promoters cause a response where many changes in enzyme activity occur and cells can take on many of the morphological characteristics of transformed cells (Boutwell, 1990). For a neoplasm to develop, cells must be exposed to an initiator then promoting agent. Progression describes the changes in a neoplasm to a more malignant character, and is a result of mutations in addition to the original initiating event.

There have been experiments in each of these stages of carcinogenesis to determine whether 50/60 Hz fields have a role and these will be summarised. Since the epidemiological evidence for 50/60 Hz field exposure being associated with an increased incidence of cancer is weak, scientists look to the laboratory evidence to provide support for this evidence. This paper reviews the evidence from the laboratory studies.

Initiation

Studies to determine if any damage occurs to the DNA have been conducted on a number of biological systems exposed to 50/60 Hz fields (Cohen, 1986; Cohen et al, 1986a, b; Reese et al, 1988; Livingston et al, 1986; El Nakas and Oraby, 1989; Krueger et al, 1975; Bender, 1976; Frazier et al, 1990; Benz et al, 1987). All concluded that 50/60 Hz magnetic fields are not mutagenic. Thus, it is generally accepted that 50/60 Hz magnetic fields are not initiators in carcinogenesis. Much of the research effort is now conducted to determine if these fields can either promote or progress cancer in initiated cells.

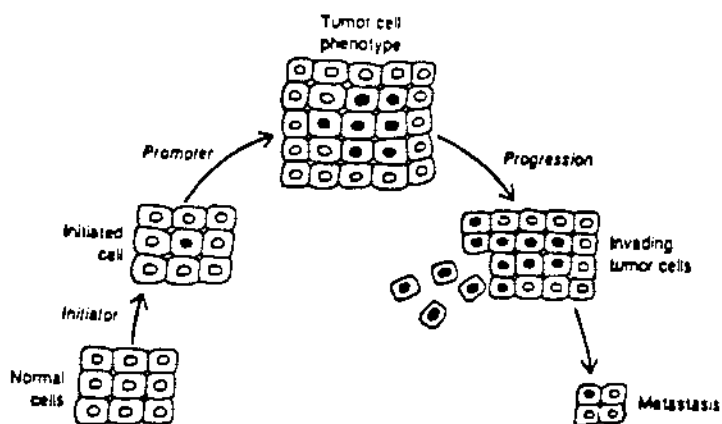

FIGURE 1 Schematic diagram (from Boutwell 1990) of changes that occur in normal cells by:
initiation - unexpressed nuclear changes (DNA damage)
promotion - expression of the phenotype of a benign tumour
progression - further nuclear/mutation-like changes leading to the expression of a malignant phenotype.

Promotion

An increasing number of researchers are investigating the different areas where 50/60 Hz fields could promote or co-promote cancer development in initiated cells or tissues: disruption of cell communication, modulation of cell growth, activation of specific gene sequences, depression of pineal melanotin production, modulation of ornithine decarboxylase activity and possible disruption of hormonal and immune system anti-tumour control mechanisms by triggering a stress response. I will deal with the evidence from the better conducted studies providing evidence for these mechanisms.

(a) In-vitro Studies

Studies with cultured human HL60 cells have reported that an increased level of specific RNA transcripts occurs in response to ELF field exposure as low as 1mV/m (Goodman et al 1990, Wei et al 1990). Using the technique of dot blot hybridization, it was observed that exposure to ELF fields increased the levels of RNA ζ_{00} β -actin, histone H2B and c-myc DNA. The changes in RNA transcripts exhibited a strong dependence on the amplitude and frequency of the applied ELF field, as well as the duration of exposure. A possible explanation of these observations is that the field alters the rate constant for one (or more) of the intermediate sequential reactions involved in RNA synthesis and degradation (Litovitz et al 1990). Increases in the synthesis of specific proteins have also been observed in other studies on cells exposed to ELF fields.

Byus et al (1987) reported that exposure of cultures of malignant cells to 60 Hz fields causes a measurable increase in ornithine decarboxylase (ODC) activity. The induction of the enzyme ODC is the largest known metabolic response to a cancer promoter and is essential but not sufficient to accomplish promotion. The maximum increase in activity reported by Byus et al was 5-fold in a mouse myeloma cell line. The increase in activity was much smaller in a human lymphoma line and the Reuber H35 rat hepatoma line. This maximal activity was observed at the end of a 1 hour exposure or within 1 or 2 hours post exposure. These observations on the extent and timing of the response differ sharply from the effect of tumour promoters on the activity of ODC, namely increases of 200-fold or more at 4 to 5 hours after a single exposure to the promoter (Boutwell, 1990). Further, the relevance of these experiments to the causation of cancer is limited because they were performed on cells that were already cancerous.

Similar experiments on the effects of a 60 Hz field on bone cells and fibroblasts by Cain et al (1986, 1990) resulted in increased ODC activity of 1.5- to 2-fold within 15 minutes to 1 hour after exposure. At 2 and 3 hours post exposure, ODC activity had returned to sham exposed levels. Although these experiments were not done with malignant cells, it is possible that the small, early increases in ODC activity were the result of gene activation. Cain et al argue that this increase in ODC activity attributable to field exposure reflects results consistent with promoting activity for 60 Hz fields. When C₃H10T1/2 fibroblasts, a cell line susceptible

to transformation, were exposed to 60 Hz magnetic fields, Cain et al (1990) evaluated the effects on the number and size of TPA-induced foci. They report that the results are consistent with tumour promotion protocols. It is important to realize, however, that while increased ODC production is an essential element of cancer promotion, the measurement of increased ODC is not per se an indicator of a cancer promotion effect (Boutwell, 1990). There are specific levels of ODC and patterns of ODC increase that must be observed before a research result can be interpreted in this way and the results of these studies do not fit the pattern expected of cancer promoters. Further, Frazier et al (1989, 1990b) using a standard, widely accepted cancer promotion protocol, found that 60 Hz magnetic fields were not able to promote the transformation of the same fibroblast cell line, (C₃H10T1/2) used by Cain et al (1990). Frazier et al do not find that 60 Hz fields cause cancer promotion when they actually test for cancer promotion; the studies by Cain et al do not test for cancer promotion.

Neither increased activation of ODC nor enhanced transcription of genes is sufficient to indicate that 50/60 Hz fields are acting as cancer promoters (Saunders et al 1991). Current in vitro studies do not support the epidemiological findings.

(b) In Vivo Studies

The question is being examined as to whether the hormone melatonin, produced by the pineal gland, can influence the growth of malignant cells. Evidence is accumulating that suggests breast cancer, melanoma and possibly other cancers may be inhibited by melatonin (Blask 1989). Since exposure to 60 Hz electric and magnetic fields may reduce the normal nocturnal rise in melatonin (Wilson and Anderson, 1989), Stevens (1989) suggests exposure to power frequency fields may account in part for an increased human breast cancer risk. However, there are no obvious biological consequences of changes in melatonin levels and the alteration in the melatonin circadian rhythm have no apparent deleterious effect on the health of test animals. Much more evidence is necessary before any suggestion that changes to melatonin levels is associated with cancer promotion.

McLean et al (1991) used an accepted in vivo cancer promotion protocol with Sencar mice (Sencar, for "sensitive to carcinogenesis") and report no difference between mice initiated with a subthreshold dose of DMBA and exposed to a 2mT 60 Hz magnetic field or sham exposed. However, McLean et al presented preliminary findings that a co-promotion effect may be occurring when an increase was observed in both the mean number of skin papillomas per mouse and the percentage of mice with papillomas in DMBA-initiated on mice treated weekly with TPA and also exposed to 60 Hz magnetic fields (2mT, 6h/d, 5d/week for 17 weeks).

Using a classical skin tumour promotion model with large numbers of animals, Holmberg et al (1991) exposed NMRI/HAN mice that had been initiated with DMBA, to 50 μ T and 0.5 mT magnetic fields for 19-21 h/d commencing 8 weeks after initiation and lasting for 103 weeks. There was no difference between exposed and non-exposed groups for

mortality, in the number of tumour bearing animals, latency for the appearance of a first skin tumour or in the total number of tumours per group. While some differences in the number of tumours per animal appeared at given weeks, no differences occurred overall when the exposed and non-exposed groups were compared.

In another large tumour promotion study, Rannug et al (1991) exposed Sprague-Dawley rats that were subjected to 70% partial hepatectomy followed 24 h later by initiation with DENA and then to 50 Hz magnetic fields of 0.5 μ T, 5 μ T, 0.05mT, or 0.5mT for 19-22 h/day. The fields were either continuous or switched (15 min on/off - 5 μ T and 0.5mT fields only). When the number of foci per unit area of liver and the number of foci per unit liver volume were calculated, continuous magnetic field exposures did not result in any consistent differences compared to control groups. Exposures to 5 μ T and 0.5mT pulsed 15 min on/off for 22 h/d resulted in a slight, non-significant increase in the number of foci per cc of liver. Overall the results did not suggest any cancer promotion effect was occurring with liver tumours.

There are a number of large animal studies being undertaken in Canada, Sweden, United States and Australia to determine if 50/60 Hz fields can promote cancer. Some of these studies will take a few years before results become available. However, the current evidence from in vitro and in vivo studies does not suggest that 50/60 Hz fields can promote cancer. There is some evidence that these fields may be cancer co-promoters in tissues that are in the process of carcinogenesis, but the health impact of such a finding remains unclear.

Progression

The effects of 50/60 Hz fields and currents on proliferation and growth of cancer cells have been studied by several investigators. Exposure to 60 Hz magnetic fields (strength 1.2 mT) were reported to decrease growth of neuroblastoma in mice (Batkin and Tabrah, 1977). However, no differences in growth characteristics were observed (Chandra and Stefano 1978) when either cultured human bronchiogenic carcinoma cells or Burkitts lymphoma cells were exposed for up to three days to 60 Hz magnetic fields. Kronenberg and Tenforde (1979) reported a similarly negative finding for mouse mammary tumour cells.

Phillips et al (1986 a,b) studied the binding of transferrin to two human colon tumour cell lines and the ability of cancer cells to form colonies after exposure to 60 Hz electric and magnetic fields (300mA/m², 0.2 mT for 24 hours). Altered expression of transferrin receptors and increases in cell colony growth were reported by Phillips and colleagues, but when their results were subjected to a laboratory visit and peer review (Cohen, 1987), it was concluded that their results were invalidated because of choice of model, experimental design and quality of data. Further Cohen (1987) was unable to replicate Phillips results. Winters (1986) reported that 60 Hz fields (up to 300 mA/m² or 0.1 mT for 24 hours) did not significantly effect responses to mitogens.

Female mice at 8 weeks of age were implanted with P388 leukaemia cells and exposed to 1.4 μ T, 200 μ T or 500 μ T, 60Hz magnetic fields for 3 hours after the implant, for 6 hours daily, 5 days per week until all of the exposed and non treated mice died (Thompson et al 1988). This life-time study found no statistically significant differences in survival, spleen weight or body weight resulting from the P388 cell implant of mice and subsequent exposure or non-exposure to magnetic fields. They also found no effect on the incidence or progression of the P388 leukaemia.

Conclusion

While more studies are necessary to determine if 50/60 Hz magnetic fields are cancer promoters or can progress cancers, the evidence so far suggests this is not the case. However, we await the results of some very large animal studies before we can be conclusive.

REFERENCES

- BATKIN S AND TABRAK F L (1977) Effects of alternating magnetic field (12 Gauss) on transplanted neuroblastoma. Res. Comm. Chem. Path and Pharm, 16:351-362.
- BENDER, H A (1976). A study of the effect of ELF electromagnetic fields upon *Drosophila melanogaster*, Indiana, University of Notre Dame (Final report, NTIS Document ADA 035956).
- BENZ, R D, CARSTEN, A L, BAUM, J W, AND KUEHNER, A V (1987). Mutagenicity and toxicity of 60 Hz magnetic and electric fields. Contractors Final Report, New York State Power Lines Project, Wadsworth Centre for Laboratories and Research, Albany, NY 12201 pp 196.
- BLASK, D. E., (1989). The emerging role of the pineal gland and melatonin in oncogenesis. In: Extremely low frequency electromagnetic fields: The question of cancer. Eds. B W Wilson, R G Stevens and L E Anderson. Battelle Press, Columbus and Richland, p319-335.
- BOUTWELL, R K (1990) Electric and magnetic fields - their relationship to the causes of cancer and the biology and molecular mechanisms of the processes associated with the appearance of cancer. Report submitted to US Environmental Protection Agency.
- BYUS, C V, PIEPER, S E, AND ADEY, W R (1987). The effect of low energy 60-Hz environmental electromagnetic fields upon the growth-related enzyme ornithine decarboxylase. Carcinogenesis, 8: 1385-1387.
- CAIN, C D, MALTO, M C, JONES, R A, AND ADEY, W R (1986). Effects of 60-Hz fields on ornithine decarboxylase activity in bone cells and fibroblasts. Technical Report, Contractors Review Meeting, DOE, EPRI, and N.Y. Dept. Health, Denver, CO, November.
- CAIN, C D, THOMAS, W J AND ADW R (1990). 60 Hz Magnetic field effects on C3H10T $\frac{1}{2}$ fibroblasts: ornithine decarboxylase-activity and focus formation in response to tumor promoter. Abstract P-2-5, 1990 BEMS Conference.
- CHANDRA, S AND STEFANO, S (1978). Effect of constant and alternating magnetic fields on tumor cells in vitro and in vivo. In: Proceedings of Eighteenth Annual Hanford Life Sciences Symposium, Richland, Washington, pp 436-446.

COHEN, M M (1986). In vitro genetic effects of electromagnetic fields. Contractors Final Report (Contract # 21082-11), New York State Power Line Project, Wadsworth Center, Albany, NY pp100.

COHEN, M M (1987). The effects of low-level electromagnetic fields on cloning of two human cancer cell lines (COLO 205 and COLO 320). Contractors Final Report (Contract # 218211), New York State Power Lines Project, Wadsworth Center, Albany, NY pp69.

COHEN, M M, KUNSKA, A, ASTEMBORSKI, J A AND McCULLOCH, D (1986a) The effect of low-level 60 Hz electromagnetic fields on human lymphoid cells. 11. Sister chromatid exchanges in peripheral lymphocytes and lymphoblastoid cell lines. *Mutation Res.*, 172:177-184.

COHEN, M M, KUNSKA, A, ASTEMBORSKI, J A, McCULLOCH, D AND PASKEWITZ, D A (1986b). Effect of low-level, 60 Hz electromagnetic fields on human lymphoid cells. 1. Mitotic rates and chromosome breakage in human peripheral lymphocytes. *Bioelectromagnetics*, 7(4):415-423.

FRAZIER, M E, REESE, J A AND MORRIS, J E (1989). Assessing the transformation and/or promotion potential of 60-Hz magnetic fields in C3H10T $\frac{1}{2}$ cells. Abstract P-1-14, 1989 BEMS Conference.

FRAZIER, M E, REESE, J A, MORRIS J E, JOSTES, R F AND MILLER, D L (1990) Exposure of mammalian cells to 60 Hz magnetic or electric fields : analysis for DNA repair of induced, single strand breaks. *Bioelectromagnetics* 11:229-234.

FRAZIER, M E, REESE, J A AND MORRIS, J E (1990a). Effect of 60-Hz electromagnetic fields on growth rates and transformation frequencies of C³H10T $\frac{1}{2}$ cells. Abstract P-3-4, 1990 BEMS conference.

GOODMAN, R., WEI, L.-X., XU, J. C. and HENDERSON, A. (1990). Exposure of human cells to low frequency electromagnetic fields results in quantitative changes in transcripts, *Biochem. Biophys. Acta*, 1009: 216.

HOLMBERG, B, RANNUG, A, ELKSTROM, T AND MILD K H (1991) A skin tumour promotion study on NMRI mice with 50 Hz magnetic fields. Presented at DOE Annual Contractors Review Meeting 3-7 November 1991, Milwaukee.

KRONENBERG, S S AND TENFORDE, T S (1979). Cell growth in low-intensity, 60 Hz magnetic field. Office of Environment for the US Department of Energy. Contract No. W.7405-ENG-48.

KRUEGER, A P, CIAROLA, A J, BRADLEY, J W AND SHREKERHAMER, A (1975). Effects of electromagnetic fields on fecundity in chickens. *Ann. New York Acad. Sci.*, 247:391-400.

LITOVITZ, T.A., MONTROSE, C.J., GOODMAN, R. and ELSON, E.C. (1990) Amplitude windows and transiently augmented transcription from exsore to electromagnetic fields, *Bioelectromagnetics* 11: 297.

LIVINGSTON, G K, GANDHI, O P, CHATTERJEE, I, WITT, K AND ROTI ROTI, J L (1986). Reproductive integrity of mammalian cells exposed to 60 Hz electromagnetic fields. Contractors Final Report (Contract # 218209). New York State Power Lines Project, Wadsworth Center, Albany, New York, pp 45.

McLEAN, J R N, STUCHLY, M A, MITCHEL, R E J, WILKINSON, D., YANG, H., GODDARD, M., LECUYER, D W, SCHUNK, M., CALLARY, E, AND MORRISON, D (1991) Cancer co-promotion in the mouse skin model by a 60 Hz magnetic field : II.Tumor development and immune response. *Bioelectromagnetics*, 12(5): 273-287.

PHILLIPS, J L, WINTERS, W D AND RUTLEDGE, L (1986a). In vitro exposure to electromagnetic fields: changes in tumor cell properties. *Int. J. Radiat. Biol.*, 49: 463-469.

PHILLIPS, J L, RUTLEDGE, L AND WINTERS W D (1986b). Transferrin binding to two human colon carcinoma cell lines: Characterization and effect of 60 Hz electromagnetic fields. *Cancer Res.*, 46: 239-244.

RANNUG, A, HOLMBERG, B, ELKSTROM, T AND MILD, K H (1991) Rat liver foci studies with 50 Hz magnetic fields. Presented to DOE Annual Contractors Review Meeting 3-7 November 1991, Milwaukee.

REESE J A, JOSTES, R F AND FRAZIER, M E (1988). Exposure of mammalian cells to 60 Hz magnetic or electric fields: Analysis for DNA single strand breaks. *Bioelectromagnetics* 9:237-247.

SAUNDERS, R.D., SIENKIEWICZ, Z.J. and KOWALCZYK, C.I. (1991) Biological effects of electromagnetic fields and radiation. *J. Radiol. Prot.* 11: 27-42.

STEVENS, R.G. (1989) Overview: ELF and carcinogenesis. In: *Extremely low frequency electromagnetic fields: The question of cancer.* Eds. B W Wilson, R G Stevens and L E Anderson, Battelle Press, Columbus and Richland, pp 9-13.

THOMPSON, R A E, MICHAELSON, S M & NGUYEN, Q A (1988). Influence of 60Hz magnetic fields on leukaemia. *Bioelectromagnetics* 9:149-158.

WEI, L.-X., GOODMAN, R. and HENDERSON, A. (1990). Changes in levels of c-myc and histone H2B following exposure of cells to low frequency sinusoidal signals: evidence for window effects, *Bioelectromagnetics* 11: 169.

WILSON, B W and ANDERSON, L.E. (1989). ELF electromagnetic field effects on the pineal gland. In: *Extremely low frequency electromagnetic fields: The question of cancer.* Eds. B W Wilson, R G Stevens, L E Anderson, Battelle Press, Columbus and Richland, pp 159-186.

WINTERS, W D (1986). Biological functions of immunologically reactive human and canine cells influenced by in vitro exposure to 60 Hz electric and magnetic fields. *Contractors Final Report (Contract # 218207) New York State Power Lines Project, Wadsworth Center, Albany, New York, pp 105.*

DOSE LIMITS REDUCTION CONSEQUENCES ON THE OPERATION OF NUCLEAR POWER PLANTS

E.Palacios, A.Curti, J.M.Espeche, G.M.Massera, F.Spano

Comisión Nacional de Energía Atómica
Buenos Aires - Argentina

ABSTRACT

Occupational doses are evaluated in each stage of the fuel cycle including nuclear power plants operation. Trends in the individual dose distributions and collective doses are analyzed. The maintenance operations with higher contribution to collective dose are identified and the implications of dose limit reduction as recommended by ICRP in 1990, are assessed. It is concluded that no relevant difficulties should appear in accomplishing with the new recommendations for installations designed after 1977. Only in Atucha I nuclear power plant which has been designed in the 60's, different alternatives should be analyzed to reduce individual and collective doses. Among them, the change of the fuel channels by new ones free of cobalt, is an essential decision to get an effective reduction of occupational doses.

INTRODUCTION

The ICRP recommendations, adopted in 1990, keep the basic criteria of dose limitation system. However the ICRP recommends a substantial reduction of the dose limits, the application of dose constraints, potential exposure analysis and the application of intervention levels, all of which have direct implications on the design and operation of nuclear installations. Nevertheless, only the dose limits reduction appears as an innovation for the Argentine regulations since all the other recommendations have already been incorporated to the standards and regulatory requirements for over a decade (1).

The fuel cycle is based on natural uranium - heavy water reactors and all the stages are being undertaken in the country. Even more, it is foreseen that in the next future, the power plants in operation will be fueled with slightly enriched uranium. Since 1983 a gas diffusion enrichment plant is in operation.

Occupational exposures are analyzed from 1981 up to 1990 for the main fuel cycle stages, in particular electric power generation. Also the practical difficulties for the implementation of the new dose limits are assessed.

OCCUPATIONAL DOSES

The collective effective dose, since now named collective dose, was estimated for the above mentioned period in 12 man Sv/year, the 85% of which corresponds to electric power generation and 14% to uranium mining and milling, and less than 1% to the fuel fabrication.

Annual individual doses for the different cycle stages have kept well below 20 mSv with the exception of the nuclear power plants operation. It is necessary to remark that since 1980 the remaining mining activities are only done in open pits.

ATUCHA I NUCLEAR POWER PLANT

The design of Atucha I (CNA I) dates back to the 60's, and as was common for other nuclear installations at that time, reactor internal parts were lined with "Stellite", an alloy with 60% of cobalt, to avoid excessive wearing-out. Co-60 is produced by neutron exposure of the "Stellite", and which in turn is carried by water along the primary circuit producing a high working ambient dose level (2) (3). As a result the collective dose is high and a considerable fraction of the personnel receives annual doses close to the limit.

The annual collective dose for CNA I, averaged over the period 1981 - 1986, is 20 man Sv/GWa approximately (4). The individual dose distributions show that around 30% received annual doses above 20 mSv (figure 1) and that a 15% of the personnel exceeded a five years cumulative dose of 100 mSv (figure 2).

Figure 3 shows the collective doses; total and due to operation excluding the major repair and maintenance works during reactor shut down. For the latter a 50% of the collective dose corresponds to interventions on the primary main pumps and steam generator while a 25% was received during moderator circuit works (5). Internal contamination due to tritium intake, contributes in CNA I with 10% to the total dose.

EMBALSE NUCLEAR POWER PLANT

This power plant was designed in the 70's and has no cobalt alloy in the internals of the primary circuit. The averaged annual collective dose from 1983 to 1990 is 1.5 man Sv; that corresponds to 3 man Sv per GWa of energy generated. The contribution from tritium to the collective dose is about 50%.

The individual dose distributions show that less than 10% of the personnel received annual doses above 20 mSv (figure 1) and that 2% to 3% of workers exceeded an accumulated dose of 100 mSv in five consecutive years.

ICRP 60 IMPLICATIONS

For Embalse the new situation does not seem to have much relevant consequences. Although the number of workers could be increased for some specific maintenance activities, this would not be too much significant from the radiological point of view and for the economical implications.

For CNA I, Regulatory Authority has tolerated that a considerable number of workers received doses close to the dose limit because this plant had been designed before the ICRP 26 were introduced.

It should be mentioned that for the building of CNA II, the Regulatory Authority required in 1981 that the use of "Stellite" should be omitted, keeping the cobalt content low in all reactor components. Nevertheless, with the new ICRP-60 recommendations reducing the dose limit to 20 mSv per year, averaged over five years, the situation in CNA I will be more difficult in the future. Increasing man power and thus fractioning the high doses for solving the problem is an option not acceptable for the Regulatory Authority. Indeed, an even greater number of workers would receive annual doses, year by year, close to the limits, and at the same time the collective dose would remain unchanged or increased. Therefore, other options such as to eliminate the source of Co-60, to decontaminate parts of the primary circuit or to introduce robots in some maintenance operations should be considered.

The Argentine Regulatory Authority has foreseen the implementation of the new recommendations by early 1992, with the necessary provision for accommodating the previous situation as soon as possible.

CONCLUSIONS

No relevant difficulties should appear in accomplishing with the new recommendations for those installations designed after 1977. The impact would be even less for those installations to be designed in the future, with the exception of underground mining, where the present 50 mSv dose limit is the main constrain in the optimization process.

In CNA I the change of the fuel channels by new ones free of cobalt is essential to get an effective occupational dose reduction and consequently to implement the new recommendations. An additional effort to lower even more the occupational doses should be done in both nuclear power plants to optimize the radiological safety.

REFERENCES

- (1) Palacios, E. "Las Nuevas Recomendaciones del ICRP y el Desarrollo de la Actividad Nuclear". Primer Congreso Regional Sobre Seguridad Radiológica y Nuclear. Buenos Aires, 1991.
- (2) Spano, F.; Righetti, M.; Hernández, D.; Massera, G. "Estimación de la contribución a la dosis ocupacional debida al Co-60 en la CNA I". III Congreso de S.A.R. Buenos Aires, 1988.
- (3) Spano, F.; Boutet, L.; Bruno, H.; Tellería D. "Modelo semi-empírico para el comportamiento de la actividad del Co-60 en un reactor PHWR" (to be published) CNEA - Argentina, 1991.
- (4) Palacios, E.; Arias, C.; Escribano, T. "Tendencia de las dosis ocupacionales en el programa nuclear argentino". International Conference on Radiation Protection in Nuclear Energy. IAEA Sydney, 1988.
- (5) Curti, A.; Espeche, J.M. "Recopilación histórica de dosis colectiva y distribución de dosis en CNA I" Informe de trabajo Nro. 144/91 - CNA I - CNEA - Argentina, 1991.

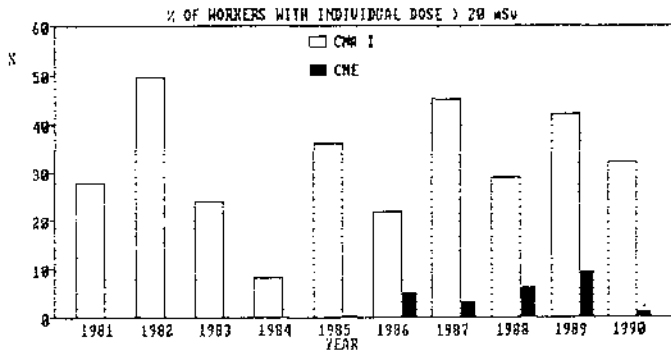

Figure 1

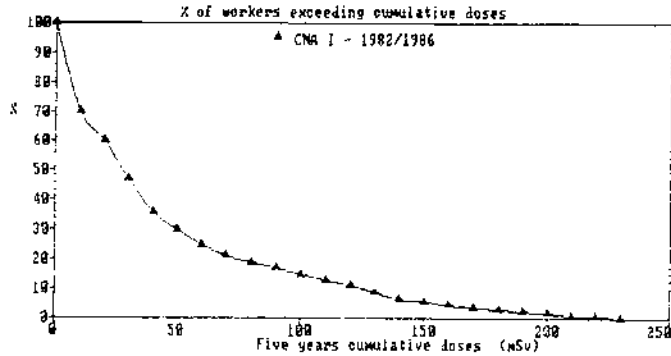

Figure 2

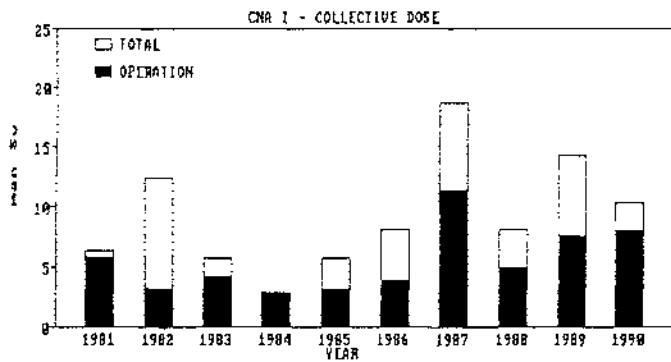

Figure 3

ASQRAD: A COMPUTER CODE FOR THE QUANTIFICATION OF RADIATION DETRIMENT

JD Robb and PJ Stokell

National Radiological Protection Board
Chilton, Didcot, Oxon. OX11 0RQ, UK

and

T Schneider and J-P Degrange

Centre d'étude sur l'Évaluation de la Protection
dans le domaine Nucléaire
BP 48, 92263 Fontenay-aux-Roses, France

Recent years have seen several new analyses of the risk associated with radiation exposure based on updated epidemiological data. This paper presents information on a personal computer code under development that will provide decision-makers and researchers with a tool to aid evaluation of these data. The key elements of the code are described in terms of its objectives, and in terms of its content. As one of the principal aims of the code is its friendliness, there is an emphasis on library and graphics facilities, as well as simplicity of use.

INTRODUCTION

During the last few years, two international organisations, UNSCEAR⁽¹⁾ and ICRP⁽²⁾ have undertaken extensive re-evaluations of information on the risks associated with radiation exposure. As a consequence, national bodies have sought to determine how this reflects on their own situation^(eg 3,4). These national studies tend to employ different sets of assumptions, and it follows that the quantitative data on risks often do not readily lend themselves to simple comparative exercises. Given that the flow of new data is unlikely to cease, and given also the range of measures of radiation detriment now being proposed to interpret risk, there is now a distinct need for a system that is capable of rationalising and encompassing all the relevant models, population distributions, and other data sets that are important in the quantification of radiation-induced stochastic effects.

This paper describes PC-based software, ASQRAD (Assessment System for the Quantification of RAdiological Dctriment), that is being developed with this aim in mind. It is the centrepoint of a joint research project between CEPN and NRPB, and largely funded under the CEC scientific programme, with the support of the Radiation Protection Committee of EdF (France).

OBJECTIVES

It is envisaged that ASQRAD (see Figure 1) will be applied in the development of policies where the radiation risk incurred or averted is an important factor in

decision-making. Obviously, it will also be of use for ongoing research on radiation detriment; it should find application in risk communication and training; and perhaps also in compensation issues. To this end, there are several features, not always associated with scientific software, that are deemed essential.

- (i) completeness: ASQRAD will accommodate all the principal health effects models, in particular those that interpret A-bomb survivor and medical exposure data, and a comprehensive range of national population parameters;
- (ii) a capacity for simple up-dating and adaptation: the user will be able to input other demographic statistics, and moreover the code is being constructed in such a way as to ensure that revised models can be readily installed;
- (iii) simplicity of use: the system will be menu driven and contain default pathways for common applications; and will be supported by help and library facilities;
- (iv) sensitivity analysis will be fully integrated; and
- (v) display and graphic facilities: a range of these will be available

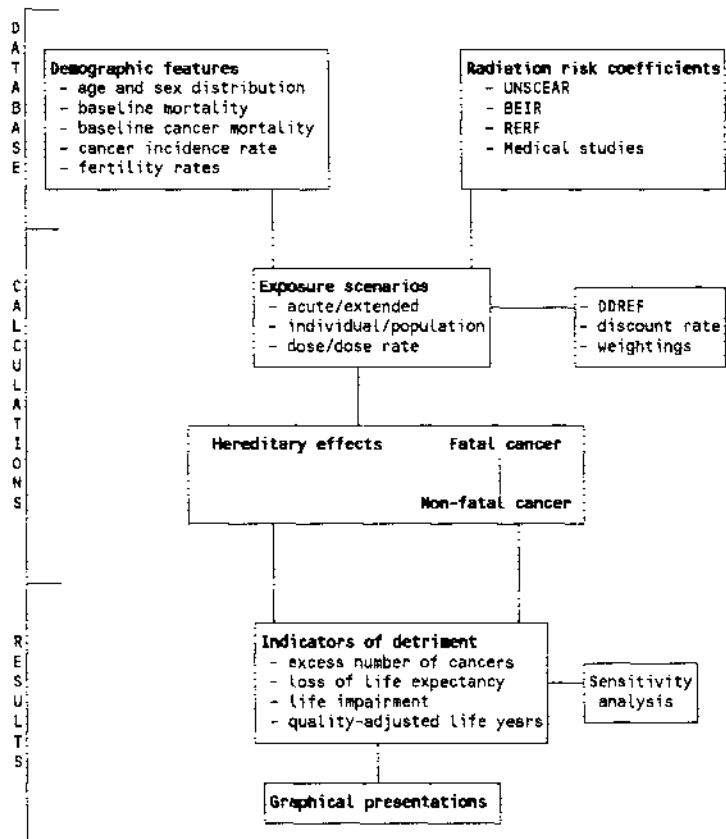

Figure 1. Outline of ASQRAD

HEALTH EFFECTS MODELLING

Risk and detriment estimates are obtained by combining 'fitted coefficients' with demographic details for a given exposure scenario. These health effects models have been developed either for specific organ sites or for groupings of sites, for example 'digestive'. There are two broad types of risk projection model applied. The additive (absolute) is where the results are independent of the baseline cancer rate in the population under consideration, and the multiplicative (relative) is where the results are a function of these baseline rates. Typically, these are becoming more complex as analysts seek to model the data more accurately, and thus often they are neither strictly additive nor multiplicative⁽⁵⁾. The code will, however, provide the user with a choice of all the relevant risk coefficients for each cancer type.

The demographic details required are a breakdown of the populations by age and sex cohorts in terms of numbers, death rates, and the cancer death rates for each site. In addition, two other sets of population statistics are used: the lethality fractions for each cancer type are needed for calculating the probability of non-fatal cancers; and the fertility rates by age and sex (the probability of an individual of given age and sex having a child during the forthcoming year) are used to calculate the probability of hereditary effects in progeny.

With all these data available, it will be possible to perform extensive sensitivity analyses. The library functions will provide background information on the data, and guidance on the legitimacy and consistency of these combinations.

OUTPUT

Measures of detriment will be calculated according to the following scenarios:

- (i) individual whole-body exposure: acute or extended (at variable annual dose), to an individual of given age or sex, or assuming an average for both sexes;
- (ii) population whole-body exposure: a single low dose and dose-rate exposure to a population (either default or user input) of mixed age and sex;
- (iii) non-uniform exposure: assuming doses to a single organ or a combination of organs; and
- (iv) committed exposure: as (iii) but assuming an intake of activity

For each of these situations, probability of cancer and hereditary effects, and associated loss of life expectancy (years of life lost, or YOLL) can be calculated directly using a chosen or default DDREF. Moreover, additional measures of detriment are proposed to take into account the severity of these effects in terms of morbidity and lost quality of life. Thus, two other expressions are introduced: years of life impaired (YOLI), and the quality-adjusted life year (QALY).

In addition, it will be possible to sum risk over different periods, for example probability of fatal cancer prior to age 75, and to make direct comparisons of radiation-attributable death rates against background death and cancer rates. The excess risk will also be assessed in terms of the excess lifetime risk (this subtracts the number of cancer deaths that would have been expected in due course in the population from the total

of radiation-induced cancer deaths) as used by BEIR V⁽⁴⁾, or the lifetime risk of exposure-induced death, as used by UNSCEAR⁽¹⁾, and in most other analyses.

It is worth adding more detail here on the QALY measure. This was originally developed in the field of health economics for the assessment of health care options that take into account the quality of life during and after treatment as well as survival rate and life expectancy. There is therefore a close parallel with the aspects of detriment that are now being incorporated into radiological protection quantities. As such, if the quality of life associated with different non-fatal, radiation-induced effects can be assessed using health indices⁽⁶⁾, then the QALY may provide for a more accurate measure of detriment than has hitherto been available. However, in keeping with the ICRP formulation of effective dose⁽²⁾, there will also be the option in ASQRAD to weight fatal effects according to YOLL, and to add a weighted non-fatal fraction based on 'curability'.

Extensive graphical presentations of the results will be provided as output in addition to the raw data. The library facility will provide information on any other measures of detriment that may be of interest in addition to those calculated, and also information on the variability and uncertainty of the data.

CONCLUSIONS

This paper has briefly presented a computer code, ASQRAD, for the calculation of the risk associated with exposure to low doses of radiation. The key features of the code are its comprehensiveness, and its simplicity of use. The aim is to produce a tool that is relevant to those decision-makers charged with decisions that require quantified assessments of radiation detriment.

REFERENCES

1. UNSCEAR. Sources, Effects and risks of ionizing radiation. 1988 Report to the General Assembly, with annexes. New York, UN (1988)
2. ICRP. 1990 Recommendations of the International Commission on Radiological Protection. ICRP Publication 60. Annals of the ICRP 21. Nos 1-3 (1991)
3. Stather, J W, Muirhead, C R, Edwards, A A, Harrison, J D, Lloyd, D C and Wood, N R. Health effects models developed from the 1988 UNSCEAR report. Chilton NRPB-R226 (1988) (London, HMSO)
4. NAS. Health effects of exposure to low levels of ionizing radiation. BEIR V Report. National Academy of Sciences. National Academic Press, Washington DC (1990)
5. Darby, S, Fagnani, F, Hubert, P, Schneider, T, Thomas, D, Vaeth, M and Weiss, K. Measures of lifetime detriment from radiation exposures: principles and methods. CEPN Report No 175 (1990)
6. Stokell, P J and Mayhook-Walker, A C. QALYs in radiological protection: a Babylonian inheritance. Radiol. Prot. Bull. No 125, 7 (1991)

UP TO WHEN ALARA IS RELIABLE?

GIAN MARIA A.A.SORDI

COMISSÃO NACIONAL DE ENERGIA NUCLEAR
INSTITUTO DE PESQUISAS ENERGÉTICAS E NUCLEARES
SÃO PAULO

ABSTRACT

The paper shows the principle problems introduced by ICRP publication 55 and provides suggestions to maximize the net benefit. The subject attacks six questions. 1- All options needed to maintain the net benefit positive. 2- The decision maker can define the optimum options by the premisses assumed. 3- The detriment of cost increases excessive when linear functions are not used. It is necessary to deal with the individual value of the protection and detriment costs. 5- The value is excessively high. 6- For the same collective dose, the preference to irradiate a large number of individuals at low doses rather than the contrary.

PROBLEM DEFINITIONS

The ICRP publication nº 37⁽¹⁾ which presents the calculation for the optimum analytical solution introduces the techniques of cost-effectiveness analysis, cost-benefit analysis, and extended cost-benefit analysis; this last technique makes the α value variable, that is the unit detriment cost of the collective dose.

The publication nº 55⁽²⁾ introduces two more techniques, the use of multi-attribute utility analysis and multi-criteria outranking analysis, giving leeway for decision taking techniques, relegating to the background the optimization as was up till then intended, that is, maximize the net benefit. This is very well demonstrated in the example of the ventilation system for a small uranium mine where it is shown that any of the first 4 techniques could be the optimum analytical solution based on the premisses adopted. It followed from the cost benefit analysis that the optimum option was nº 1. But when the qualitative manner of individual doses is introduced the optimum option becomes number 2 or 4. When the discomfort factor provoked by the ventilation is included the optimum option becomes number 3. In the extended cost-benefit analysis, considering the individual dose distribution factor, the optimum option returns to be number 3. In the multi-attribute utility analysis the optimum option could be number 3 or 4 depending on the importance given to the discomfort factor produced by the ventilation system. In the multi-criteria outranking analysis it is proven that and exclusion criterion of 0,5 presents two solutions, these being option 3 and 5 and that to eliminate option 5 it must be taken as exclusion criterion the value of 0,6.

This publication disengages a series of problems, six of which are made salient herein:

PROBLEM 1- The ICRP does not take the trouble to show that for not one of the 5 options does the benefit become $B < 0$ in proportion to the sum of protection costs, X , plus the increase in detriment cost, Y . This sum deviates from a factor of 3 for the same options to 2 between different options.

PROBLEM 2- Because an optimum analytical solution depends on the imposed conditions by the decision-maker, the graph of traditional optimization, figure n° 1, passes to that of figure n° 2.

PROBLEM 3- The linearity relationship between collective dose and detriment cost, so much, proclaimed in publication 22⁽³⁾, items 2,3,29 and 30 as well as in publication 26⁽⁴⁾, items 28 and 30 and in publication 55⁽²⁾, item 145, ceases to exist even through it is already considered to conservative. For this case the optimization graph becomes that shown in figure 3.

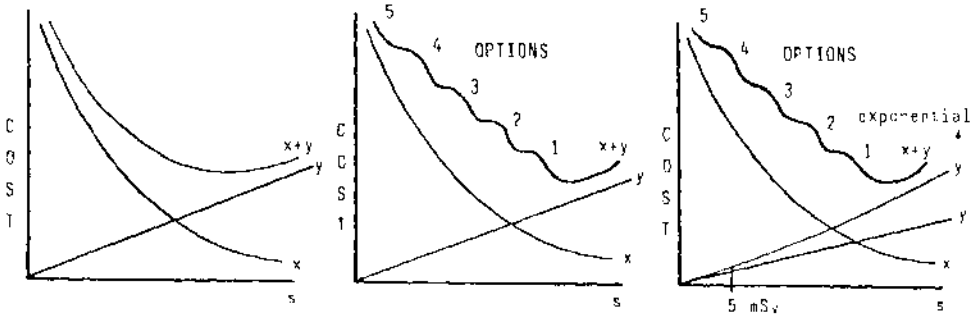

Fig. 1 - Traditional Optimization.

Fig. 2 - ICRP-Publication 55 - Proposed Optimization.

Fig. 3 - ICRP-Publication 55 - Proposed Optimization with Y Exponential.

PROBLEM 4- We know that B is maximum when $(X+Y)$ is at minimum but nothing is said in respect to each of these two last terms. In many countries these costs come from different sources and each has an interested to minimize expenses. On one side X is a real guaranteed immediate cost spent by executor of the service and Y is a probabilistic cost, not definite, with a long period of time for despenses. In agreement with item 98 of ICRP publication 26⁽⁴⁾ the average life lost by a worker with radiation is uniquely 10 years and when it is necessary to lay out the money now foreseen probably the techniques for cures will have advanced and the cost declined. For example, some years ago carcinogenic breasts were removed which is not done any more; people died of thyroid cancer but now the thyroid is removed and the patient is saved, etc.

PROBLEM 5- The very high value of α is still more than that adopted by ICRP, with an average value for the world of 3 to 5 times higher than the real value as some specialists assert. In

this case the source who pays for the detriment estimates a cost from 6 to 10 times the real cost in detriment to the other source which evaluates real costs. This is contrary to that presented in many ICRP publications that dictate we be as realistic as possible in the evaluation of doses and consequently unfavorable to the detriment cost during the optimization calculation for the purpose to evade discarding. The use of radiation in favor of another technique which offers higher risks but were move realistic in the calculations. Some publications and respective items that assert the realistic condition are: Publication 22⁽³⁾, annex II, Publication 26⁽⁴⁾, item 30, Publication 35⁽⁵⁾, items 36 and 84, and Publication 55⁽²⁾, items 38 and 55.

PROBLEM 6- The ICRP gives emphasis to the preference to irradiate a maximum number of individuals in low dosage rather than a small number with high doses for identical collective doses. Since in both cases the doses for the optimization calculation are below the annual limits and therefore inside the linear zone between dose, detriment, and biological effect, the emphasis should be the contrary.

For example: If 20.000 people were irradiated with a dose of 1 cSv having a probability of death of $4 \times 10^{-4} \text{ cSv}^{-1}$, we can say 8 people die by dose effect. On the other side having 10.000 people irradiated with a dose of 2 cSv with the same probability of death we would have only 4 deaths by radiation. Conclusion, the probability of death increased by a factor of 2 but the number of deaths decreased by a factor of 2.

RECOMMENDATIONS AND POSSIBLE SOLUTIONS

- For the first problem instigate the recognition of the calculation of B for the justification of the activity. With this calculation realized you can evaluate the maximum value of $(X+Y)_{\max}$ which makes $B=0$ and this will constitute a second constraint in addition to dose limits. Item 32 of Publication ICRP-55 discusses the dividing line of $B=0$. We suggest therefore an ICRP publication with a practical guide for the calculation of the justification showing how other factors could be inserted in addition to those of economic and social.

- For the second problem it should be remembered that the decision taken depends on the justification and not on optimization, and this subject is very well explained in items 32 and 33 of ICRP Publication 55. We urge therefore that the technical factors which enter into the calculation make themselves with their relative importance as partial parameters of the X and Y factors and that the sensibility study with its variation should be within technically justifiable intervals. We suggest a re-edition of ICRP Publication 55 with this eminent technical character and leave the decision which has no technical connotation to those which have the authority.

- For the 3rd problem the ICRP should decide what is the most realistic relation in light of actual knowledge between dose, de

triment, and cost when the doses are below the limits and make this relation or relations valid of all cases. The detriment cost should be established by the competent authority of the country based on the ICRP recommendations. The relation or relations between those three parameters, having various bands of dosage, should be published by the ICRP with urgency.

- For the 4th problem we should take into account the pair X and Y and because of reasons put forward we suggest and evaluation of $X=y$ or $X < Y$ in addition to $(X+Y)_{\min}$. The new edition of ICRP Publication 55 should attack this^{min} problem and manage to clarify it.

- For the 5th problem, since the distribution of doses varies in the different options; different values of α change the panorama of the optimum solution and therefore this value should be extremely realistic, even more so than of the proper dose, since that the interest is to encounter the differences between the options. Thus we suggest that the ICRP realizes an evaluation of the calculation for α and publish this as soon as possible. Excessively high values of α permit the choice of high risk techniques only due to the fact that we have excessively conservative numbers.

- For the 6th problem we suggest that the ICRP technically show if our example constitutes a sophism or not. In the negative case we eliminate from ICRP publication 55, since that all considered doses are below annual limits, the discussion with respect to a large number of individuals radiated with small doses or a small number radiated with doses higher for the same collective dose value.

REFERENCES

- (1) ICRP Publication 37: "Cost-Benefit Analysis in the Optimization of Radiation Protection", 1983.
- (2) ICRP Publication 55: "Optimization and Decision-Making in Radiological Protection", 1989.
- (3) ICRP Publication 22: "Implications of Commission Recommendations that Doses be kept as Low as Readily Achievable", 1973.
- (4) ICRP Publication 26: "Recommendation of the ICRP", 1977.
- (5) ICRP Publication 35: "General Principles of Monitoring for Radiation Protection of Workers", 1982.

**A STUDY OF THE HUMAN URINARY EXCRETION OF CHRONICALLY INGESTED URANIUM -
INSIGHTS ON THE GASTROINTESTINAL ABSORPTION FACTOR**

M. LIMSON ZAMORA, J. ZIELINSKI, AND R. FALCOMER

BUREAU OF RADIATION AND MEDICAL DEVICES
DEPARTMENT OF NATIONAL HEALTH AND WELFARE
OTTAWA, CANADA

ABSTRACT

A study was conducted in two Canadian towns to determine the feasibility of using urinalysis data to estimate uranium uptake where exposure is through the chronic ingestion of soluble natural uranium in drinking water. Forty-three subjects participated in the study. Uranium levels in drinking water varied from 5 to 376 $\mu\text{g/L}$, and intakes ranged from 3 to 628 $\mu\text{g/day}$. Urinary excretion varied from 1 to 10 $\mu\text{g/day}$. Variation of the gut absorption factor (f_1) correlated poorly with gender, years of residence, and age, while significant negative correlation was obtained with intakes greater than 9.5 $\mu\text{g/day}$.

INTRODUCTION

Despite numerous studies on the metabolism of uranium, there is still considerable uncertainty regarding the most appropriate value of the f_1 factor to use in the calculation of doses from uranium exposures. Values reported in the literature [1,2] have varied from less than 1% to as much as 32%. A number of human studies have been undertaken to estimate its value; but most have been conducted under conditions of acute exposure. Except when accidents occur, most exposures are chronic in nature. This is particularly true of environmental exposures.

This investigation was undertaken to determine how closely urinary uranium reflects uptake in the gut following chronic uranium ingestion, and to arrive at a "best estimate" of the f_1 factor to use in dose assessments.

METHODS

The subjects for the study were selected according to age, gender, health status, and years of residence in the towns that were studied. Twenty-two male and twenty-one female residents of the two towns with as good a spread in age between 20 and 70 years, and who had lived in the area from a minimum of 17 months to a maximum of 43 years, participated in the study. All were in good health, and were not subject to kidney problems or other complicating pathology. Two couples in one community requested that their three children - ranging in age from 5 to 14 years - be included in the study. Participants were asked to submit 24-hour urine specimens and samples of tap water collected at home and at work. Questionnaires were used to estimate total water intake, including water-based beverages, over a 7-day period. Laser-induced phosphorimetry was used to

measure the uranium content of samples.

Two assumptions were made in the design of the study and the interpretation of the results obtained. Subjects were assumed to be in a state of equilibrium insofar as their uranium excretion vis à vis their intake was concerned. Food was assumed to make a minor or even negligible contribution to uranium intake, compared to water. This was considered reasonable, based on the reported [3] factor of 10^{-3} for the bio-concentration of uranium by staples and garden vegetables grown in contaminated soil.

RESULTS AND DISCUSSION

The wide variability reported in the literature [1,2] for the value of the f_1 factor was also observed in this study, with values ranging from 0.2% to 61% of intake. Uptake data, separately or pooled between locations, were found to be gender-insensitive ($p < .60$). There appeared to be poor correlation between f_1 values and years of residence. This observation supports the assumption that the subjects were in a state of equilibrium with respect to uranium intake and excretion.

The variation of the f_1 values with intake expressed as $\mu\text{g}/\text{day}$ was examined. For intakes ranging from 3.0 to 9.5 $\mu\text{g}/\text{day}$, the correlation with the f_1 factor was poor ($p < .40$). For intakes greater than 9.5 $\mu\text{g}/\text{day}$ and up to 628 $\mu\text{g}/\text{day}$ the best fit was obtained with a power function, with negative correlation being significant at the 99% confidence level (Fig.1). One possible explanation for these observations may be that for f_1 values that correspond to lower daily intakes, food uranium may represent more than a minor fraction of the total amount ingested, contrary to what was originally assumed in this study. A second and more intriguing explanation may be that above a certain level of daily intake (9.5 μg in this study), uptake in the GI tract decreases to a minimum, because some "mechanism" for gut uranium absorption becomes saturated when challenged with increasing uranium intakes.

Statistical tests for correlation also demonstrated that the f_1 values were age-independent. However, an examination of Figure 2 suggests that the f_1 factor may not be altogether age-insensitive. The higher concentration of elevated values at ages greater than 54 years might suggest some release of uranium from bone deposits in these individuals; that is, that these individuals may be in negative uranium metabolism, a phenomenon that has been reported, in older humans, for calcium which is also a bone-seeking element. In contrast, the low values (.004 to .025) for the minors (ages 5 to 14 years), might suggest deposition. The assumption that following prolonged exposure, all individuals are in equilibrium and that therefore, their daily urinary uranium output should be approximately equal to their daily uranium uptake, may have to be reexamined. Excretion in urine may indeed be less than the uptake, if in growing children, uranium deposition is actively taking place during bone development.

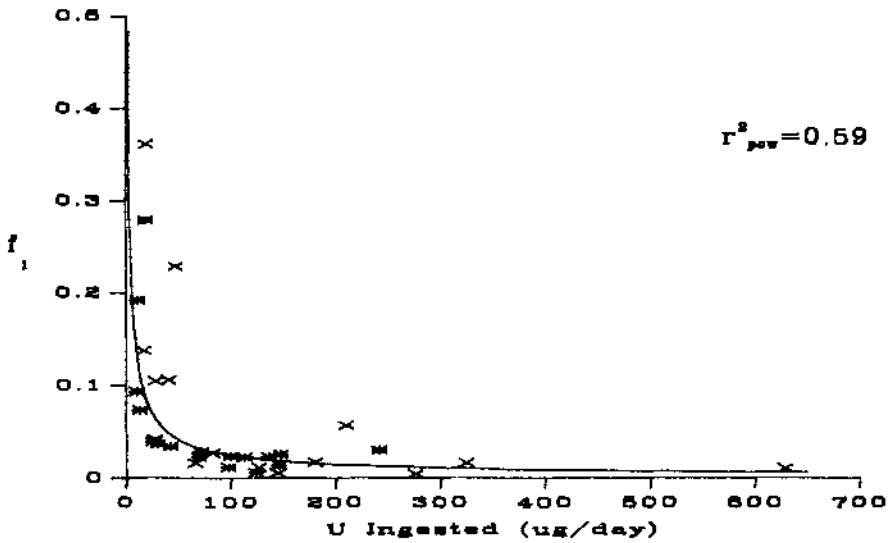

Fig. 1. Fractional gastrointestinal absorption of uranium as a function of intake ($\mu\text{g U/day}$). Data from a study of two towns were pooled and include uranium intakes ranging from 10 to 628 μg per day.

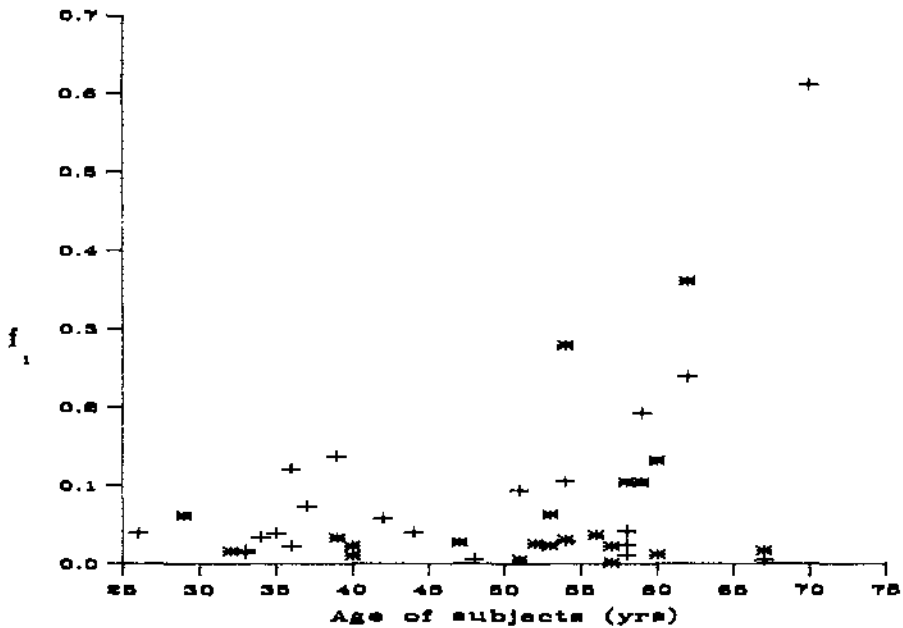

Fig. 2. Scatter plot of f_1 values versus the age of male (+) and female (*) subjects.

FURTHER STUDY

The above insights suggest certain areas that require further investigation. A mass balance study of total intake (water plus food) versus total excretion (urinary and faecal elimination) is proposed. This should provide answers regarding the role of food in uranium ingestion, as well as the possible existence of a saturable GI absorption mechanism. It is also proposed that a greater number of minors and subjects fifty years of age or older be included in the study in order to reevaluate whether or not the f_1 factor is age-dependent.

REFERENCES

1. HURSH, J.B. and SPOOR, N.L. 1973. Uranium, Plutonium, and Transplutonic Elements. Springer-Verlag, New York.
2. WRENN, M.E. et al., 1985. Metabolism of Ingested U and Ra, Health Physics, 48(5):601-633.
3. COTHERN, C.R., and LAPPENBUSCH, W.L., 1983. Occurrence of Uranium in Drinking Water in U.S. Health Physics, 45(1): 89-99.

EVALUATION OF INTERNAL CONTAMINATION DOSE TO EMBRYO AND FETUS

F. Breuer, L. Frittelli
Italian National Agency for New Technology, Energy and the
Environment, Via V. Brancati 48 00144 ROMA

ABSTRACT

In its Publication n. 60 the ICRP recommends that the methods of protection at work of women which may be pregnant should provide a standard of protection for any conceptus broadly comparable with that provided by the System of Protection for members of the general public. The Commission's policy could not be satisfied following maternal internal contamination before the declaration of pregnancy by some radionuclides homogeneously diffused into the body as ^{137}Cs and ^3H .

Antenatal exposure to ionising radiation seems to be likely to cause (1) an undetectable death of the conceptus before the beginning of organogenesis, deterministic effects (malformations), with an estimated threshold to be about 0.1 Gy, during the period of major organogenesis and an increased probability of cancer in the live-born. To limit to a tolerable level the health effects affecting the conceptus following the mother's occupational exposure the Commission recommends that the methods of protection at work of women which may be pregnant should provide a standard of protection for any conceptus broadly comparable with that provided by the System of Protection for members of the general public. The Commission states that its policy seems to be adequately applied if the mother is exposed, prior to a declaration of pregnancy, according to the recommended protection system, including the respect of the occupational dose limits and of the source-related dose constraints, if any. The exposure of women which may be pregnant is thus not believed by the Commission to require specific arrangements and no special occupational dose limits for women are in general recommended, owing to the substantial reduction (by a factor 2/5) in the dose limits for workers. Once the pregnancy has been declared the conceptus should be protected by applying a supplementary equivalent dose limit to the surface of the woman's abdomen of 2 mSv for the remaining of the pregnancy and by limiting intakes of radionuclides to about 1/20 of the ALI. Exclusion should be considered from jobs carrying a significant probability of high accidental doses and intakes.

The application of these recommendations seems to be straightforward in the case of external exposure, but a deeper analysis could be required in the case of internal exposure. Some computations (2) of the fetus equivalent dose received following the continuous internal exposure of the mother under the annual limit recommended for the members of the public

(roughly 1/20 of the Annual Limit on Intake for workers) confirm that the resulting dose can be very small and satisfying the general Commission's policy regarding the occupational exposure of women. Some doubts could however arise in the case of occupational exposure of women which could be pregnant, owing to the flexibility in averaging the intakes over five years allowed by the Commission's Recommendations. This is because keeping the exposure of women which may be pregnant at an approximately regular rate, is no longer recommended. Some exposure scenarios should be investigated to verify that a significant dose to the conceptus can be excluded following the occupational exposure of the mother before the beginning of the pregnancy, even if the recommended exposure conditions are satisfied.

The equivalent dose to the different organs or tissues following the intake of a radionuclide into the body depends on the type and energy of emitted radiations, on the distribution of the radionuclide in the source organs, and on the mean residence time in the different organs and tissue, determined by the physical half-life and by the biological retention period. There are not general methods for calculating equivalent dose to the developing embryo and fetus following intake of radionuclides by the mother before the declaration of pregnancy (2). Two different aspects should be considered for the irradiation of the conceptus: a) by penetrating radiation emitted from radioactive materials deposited in the mother's organs; b) by non penetrating radiation emitted from material deposited in the fetal organs and tissues. In the first case, owing to the lack of more complete information, it can be generally assumed that the dose to the embryo up to the end of the second month of gestation is equal to the dose to the uterus. For the second case the selectivity of the placenta will be very often the most important factor. Following the entry into fetal and mother's body fluids, information is ideally required on the initial uptake of radioactivity by the fetal tissue during the very early stages of gestation, on the activity distribution and retention in developing fetal organs and tissues and also on the extent in which activity is translocated to the fetus from the maternal tissue, which could behave as a reservoir after the end of the direct intake by the mother. In the different exposure scenarios discussed in the following reference is made to the radioactive materials which are mostly present in the work-place, by selecting from the different groups characterized by a particular metabolic behaviour the radionuclide which can produce a not negligible exposure of the embryo and fetus.

A continuous exposure to 1 ALI per year of ^{239}Pu (i.e an intake of 300 Bq for class W (3)) has been assumed as critical with reference to bone seekers radionuclides. The largest fraction of bone seekers taken-up into the body-fluids is deposited in the mother's bone and only a minor fraction is available for the fetus, even without taking into account the placental discrimination factor. Literature data (4) relative to ^{90}Sr , for which the placental discrimination factor seems to

be very small, show that the concentration in fetal bone at time of birth is equal or lower than in mother's bone. According to other results (5) we can thus expect for actinides a low concentration in fetal bone, causing to it a dose lower than that received by the mother's bone. The actinide concentration in soft tissue can also be assumed to be equal to the concentration in maternal uterus. Considering a biological half-life of 500 days and a dose-factor of 1 $\mu\text{Sv/Bq}$ (6) we obtain for a continuous constant intake at the level of 1 ALI/year, stopped after the first month of gestation, a total fetal dose of about 0.34 mSv. According to the flexibility allowed by the System of protection in averaging the intakes over 5 years we can also consider a further acute intake of 1 ALI just before the beginning of the pregnancy, because the requirement of an approximately regular exposure no longer holds. The fetus could so receive an additional dose of 0.24 mSv during the following gestation time, with a total dose amounting up to 0.58 mSv. For bone-seeker radionuclides, in particular actinides, the occupational exposure of the mother under the exposure conditions recommended in 1990 ICRP Recommendations seems to bear no problems for the exposure of the conceptus.

Owing to its importance in industry, in research places and in nuclear medicine ^{131}I has been selected among the radionuclides characterized by a selective affinity for an organ or tissue. Human data on which a dosimetric model can be based are also available for this radionuclide (7). Owing to short physical half-life the acute exposure to 1 ALI (800 kBq) can be assumed as critical. Fetal and maternal tissues other than the thyroid will receive an equal dose around 0.032 mSv, assuming a committed dose of 40 pSv/Bq (6). No significative thyroid irradiation could reasonably be assumed before the declaration of the pregnancy, owing to the short half-life of ^{131}I . A larger, but always small thyroid dose could be evaluated for ^{125}I . Exposure during the pregnancy at the recommended value of 1/20 of the ALI could cause, between the third and the sixth fetal months, the dose to the thyroid of the fetus to exceed the maternal thyroid dose by a factor no larger than two. Maternal exposure to radioiodine under the conditions suggested by the Commission would cause no deleterious deterministic effects to the fetus, but only a small overcome of the risk of stochastic effects allowed for the members of the public.

For radionuclides which diffuse homogeneously within the human body (i.e. ^{137}Cs and ^3H) an homogeneous diffusion into the fetal tissues is assumed, with a dose rate equal to that delivered to maternal soft tissues. Assuming a continuous constant inhalation of 1 ALI/year (2 MBq/y) of ^{137}Cs an equivalent dose of about 1.7 mSv will be received by the embryo during the first month after the beginning of the pregnancy (i.e. up to the time of the diagnosis). Moreover, considering for cesium in the pregnant woman a biological half-life of 50 days, an additional dose of 3.8 mSv will be received over the next months, up to the exhaustion of the maternal cesium

burden, leading to a total fetal dose of 5.5 mSv. In the case of a single intake of 1 ALI just before the beginning of the pregnancy, taking into account the different biological half-life during the pregnancy, the embryo will receive a dose of 12 mSv during the first two months, and a dose of 8 mSv during the following seven months. For internal contamination by tritium the total dose will be received in short time after a single acute intake, namely 99% in the first 60 days. The whole committed dose to the soft tissues of the embryo (about 20 mSv) can therefore be received soon after the intake. As a conclusion, when the exposure conditions recommended in ICRP Publication 60 are satisfied, maternal exposure from radionuclides homogeneously diffused within the body could cause the fetus to receive a dose significantly larger than that allowed for the members of the public, even if the value of the dose seems not to be large to cause deterministic effects. The Commission's policy aimed to protect the conceptus by protecting the mother seems to be not completely satisfied.

For trace radionuclides like zinc, nickel, cobalt, technetium, etc. literature data (4) show in some fetal organs values of concentration larger than in maternal organs. Since the kinetics of these radioelements in fetal organs is not known, it is not possible to calculate the fetal dose due to the maternal contamination. It seems proper therefore to recommend a particular caution in the exposure of women of reproductive capacity to this group of radioelements.

REFERENCES

1. Recommendations of the International Commission on Radiological Protection. ICRP publ. 60. Pergamon Press, Oxford, 1991.
2. Phipps A.W. et al.: Committed Equivalent Organ Doses and Committed Effective Doses from Intakes of Radionuclides. NRPB - R 245, Didcot 1991.
3. Annual Limits of Intake of Radionuclides by Workers Based on the 1990 Recommendations. ICRP Publ. 61. Pergamon Press, Oxford, 1991
4. Gerber G.B., McTivier H., Smith H., Editors : Age-related Factors in Radionuclides Metabolism and Dosimetry. Martinus Nijhoff publ. Dordrecht 1987.
5. Weiss J.F. et al.: Placental Transfer of Americium and Plutonium in mice. Health Physics, 39,903,1980.
6. Age-dependent Dose to Members of the Public from Intake of Radionuclides. Part. 1. ICRP Publ. 56. Pergamon Press, Oxford, 1990.
7. Johnson J.R.: Fetal Thyroid Dose from Intakes of Radioiodine by the Mother. Health Physics, 43,573,1982

APPLICATION OF THE PROPOSED NEW ICRP LUNG MODEL TO BIOASSAY

J. R. Johnson, A. C. James, and R. L. Hill

Pacific Northwest Laboratory
Richland, Washington 99352

ABSTRACT

The new lung model being proposed by the ICRP for use in radiation protection dosimetry requires calculating doses to separate regions of the respiratory tract, multiplying these doses by factors proportional to the risk per unit dose to each region, and summing over all regions of the lung to give a "weighted" lung dose. This paper compares the doses that would be calculated from bioassay measurements using the new model with those calculated using the current model, which basically uses total lung burden to estimate lung dose.

INTRODUCTION

The current ICRP lung model was developed over twenty years ago.⁽¹⁾ In its Publication 30, the ICRP modified the model only slightly in developing the Limits for Intakes of Radionuclides by Workers. Research during the past twenty years and experience with the model have indicated a number of areas where the current model can be improved for radiation protection purposes. Although the current model is sufficiently accurate for developing limits for intake of radionuclides for occupational exposures,⁽²⁾ it has a number of inadequacies. It does not allow for calculation of doses to airways in the head region; the clearance categories based on solubilities of radionuclide compounds are not valid in many cases; and the model is not readily useful for interpretation of bioassay data. These and other inadequacies, as well as the desire to incorporate the results of studies undertaken in the last 20 years, led the ICRP to initiate the development of a new lung model.

MODEL DEVELOPMENT AND CALCULATIONAL RESULTS

The process of developing the new lung model has been one of developing models of deposition, clearance, risk, and dosimetry. Development of these models has been described in detail previously.⁽³⁾

The underlying concepts for the model development are shown in Fig. 1. Material deposited in the extrathoracic (ET) region of the respiratory tract is known to clear quickly, both externally as well as to the gastrointestinal (GI) tract [$G_{ET}(t)$]. Material deposited in the thorax is either cleared within a few days (T_f), or more slowly (T_s) by mechanical

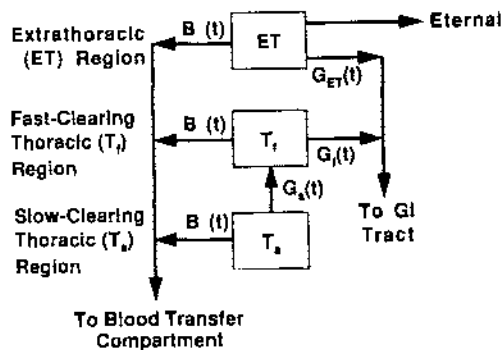

Fig. 1. The underlying concepts used as a basis for developing the new lung model.

processes $[G_i(t)]$. Clearance by translocation to blood takes place from all regions at the same fractional rate $[B(t)]$. The current implementation of these concepts into a compartment model is shown in Fig. 2. Mechanical clearance half times to the GI tract from these compartments are as follows: naso-oropharynx larynx = 10 min; bronchi = 100 min (fast) and 23 d (slow); bronchioles = 8 h (fast) and 23 d (slow); alveolar interstitium = 35 d, 700 d, and 7000 d. Clearance rates to the blood from all compartments are assumed to be equal. Default half lives, which are given for fast (F), medium (M), and slow (S) clearance (F, M, and S are similar to D, W, and Y in the old model), are: 10 min for F; 50% at 3 d and 50% at 100 d for M; and 0.1% at 15 min and 99.9% at 6930 d for S.

Recommended weighting factors for the different parts of the thoracic region are bronchi = 0.8, bronchioles = 0.15, alveolar-interstitium = 0.05, and thoracic lymph nodes = 0.001. These choices cause the ratios of dose-rate to thoracic-burden to vary with the time after an intake. Fig. 3 gives the relationship for Class S material (a). The current model assumes that the dose rate is always proportional to thoracic burden; however, if the activity in the lymph nodes is assumed to have very little risk, as in the new model, the current model (Fig. 3[b]) would also show a decrease in the ratio of dose-rate to thoracic-burden with time.

Fig. 4 gives comparisons of the current and new model results for uranium excretion in urine. The urinary excretion calculated for classes S and Y is much smaller using the new model because of the much lower predicted clearance to blood. Similarly, the peak in the ratio at about 100 days in the M/W ratio results because the current lung model has essentially emptied the lung by this time; hence, very little material is available for mechanical clearance. Ratios for fecal

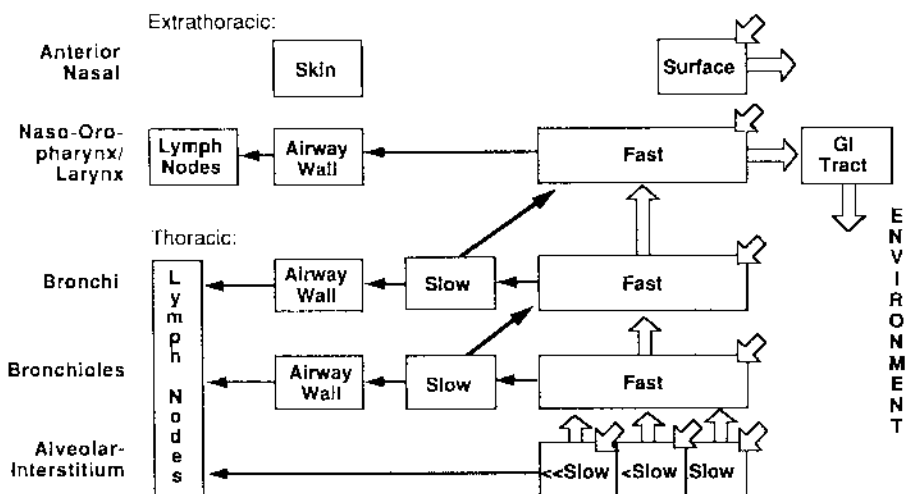

Fig. 2. The compartment model developed by the Task Group to implement the conceptual model shown in Fig. 1. The first order kinetics with constant fractional clearances used with the model results in easy computer implementation.

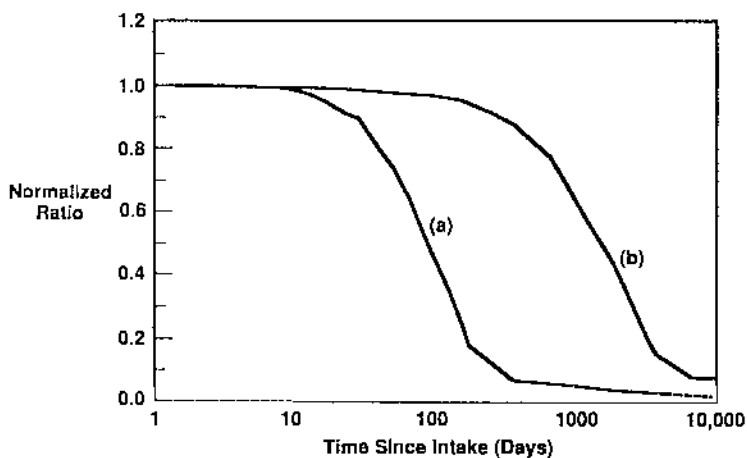

Fig 3. Ratio of lung dose rate to lung content for Type S (Class Y) alpha-emitting material.

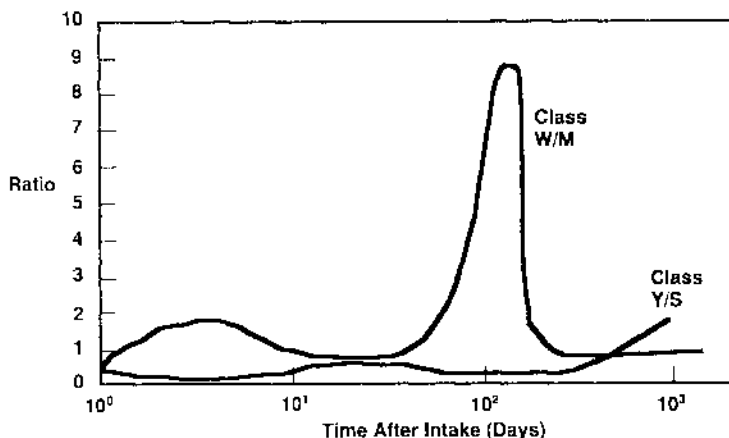

Fig. 4. Ratio of uranium excretion rates for the current and new lung models.

excretion of Y/S material show a broad peak at 5 to 50 days because the new model predicts much higher mechanical clearance of insoluble materials during this time period.

CONCLUSION

The new lung model is nearing completion. Its structure will allow easier matching of bioassay results to model predictions, and dose estimates will be better related to risk. However, the estimates of dose will be somewhat more difficult, and a conservative approximation of the actual dose may be necessary.

ACKNOWLEDGMENT

Pacific Northwest Laboratory is operated for the U.S. Department of Energy by Battelle Memorial Institute under Contract DE-AC06-76RLO 1830.

REFERENCES

- (1) Task Group on Lung Dynamics. 1965. "Deposition and Retention Models for Internal Dosimetry of the Human Respiratory Tract." Health Phys. 12:173-207.
- (2) International Commission on Radiological Protection. 1982. Limits for Intakes of Radionuclides by Workers. ICRP Publication 30, Pergamon Press, New York.
- (3) Papers presented by Members of the ICRP Lung Model Task Group at the Third International Workshop on Respiratory Tract Dosimetry, Albuquerque, New Mexico, July 1-3, 1990. Radiat. Protect. Dosim. (in press).

A ROLE OF THE HYBRID SCALE IN RADIATION PROTECTION

Shigeru Kumazawa

Department of Health Physics
Japan Atomic Energy Research Institute
Tokai-Mura, Ibaraki-Ken, 319-11, JAPAN

ABSTRACT

The hybrid scale, first introduced for the purpose of reasonable control of occupational exposure, has been expanded to generally apply it to various subjects in radiation protection. The merit of using the hybrid scale is discussed so as to control radiation risks as best as possible. New graph papers derived from the hybrid scale are systematically presented and their potential application is suggested.

INTRODUCTION

Both linear and logarithmic scales are widely used in radiation protection. The former is apt to describe variations of the same order of magnitude, e.g. levels of natural gamma radiation by time, while the latter is apt to describe variations of the different order of magnitude, e.g. levels of workplace radiation varied by operation of a nuclear facility. In radiation protection, however, there is another type of variations which consists of both the different order of magnitude in the lower range of variations and the same order of magnitude in the higher range. This type of variations needs a new type of scale of hybridizing a logarithmic and a linear scale in various ratios.

The first example of the scale for the hybridization was the variate coordinate axis on hybrid lognormal probability paper¹. The scale, termed a hybrid scale, was developed to be given the meaning of variations of individual doses controlled by radiation protection practices^{2,3}. The hybrid scale seems to be useful for assessing not only the control of dose to workers, but also the control of other quantities in radiation protection. Especially it is important to discuss how degree the system of radiological protection recommended by the ICRP needs the hybrid scale.

The 1990 ICRP Recommendations provide detail background information on biological effects of ionizing radiations. Some of the biological effects can be displayed more properly on hybrid graph paper than on linear or log graph paper^{4,5}. Therefore the new graph papers using the hybrid scale are systematically presented to explore the potential application in radiation protection.

METHOD

The standard hybrid scale is defined $y = \text{hyb}(t) = \ln(t) + t$, where the scale has marks of t at distances of y apart. This is the same as the log scale $y = \ln(t)$ or the linear scale $y = t$. The

hybrid scale approaches the log scale for $t \ll 1$ and the linear scale for $t \gg 1$ because the function is $\text{hyb}(t) \approx \ln(t)$ for $t \ll 1$ and $\text{hyb}(t) \approx t$ for $t \gg 1$. If the log term is equal to the linear term, that is, $y=0$, the value of t is about 0.567143.

Suppose a quantity x is of the different order of magnitude in the lower range of x and of the same order of magnitude in the higher range of x , a procedure to use the hybrid scale for x is as follows:

- 1) find a proper positive value of ρ having the reciprocal unit of x so that the value of $y = \text{hyb}(\rho x)$ should be of the same order of magnitude over the substantial range of x ,
- 2) calculate the value of $t = \rho x$ and plot it on a hybrid scale of t , or plot x directly on a hybrid scale of x which has marks of x calculated by t/ρ for a fixed proper value of ρ at distances of y apart.

Thus the locations of quantities x plotted on a hybrid scale represent the distances corresponding to the values of $y = \text{hyb}(\rho x)$. The value of $x_c = 0.567143/\rho$ is corresponding to $y=0$ and is termed a "critical point" between log and linear regions.

APPLICATION OF THE HYBRID SCALE TO DATA

The variations of annual dose to workers must reflect the effectiveness of a system of radiation protection. Analyzing the 1988 data of occupational exposure in Japan, we have the mean 1.7 mSv, $\rho = 0.3249 \text{ mSv}^{-1}$, and $x_c = 1.7 \text{ mSv}$ for nuclear industry the mean 0.4 mSv, $\rho = 0.0293 \text{ mSv}^{-1}$ and $x_c = 9.4 \text{ mSv}$ for medicine. Figure 1 shows quite different hybrid scales between nuclear industry and medicine. However a similar hybrid scale is applicable for each occupation over years.

The variations of annual collective dose per reactor must also reflect the ALARA efforts through regulatory activities. The 1983 data of annual collective dose to workers per reactor of PWRs licensed by the USNRC, was analyzed; $\rho = 0.0790$ (person-Sv/reactor) $^{-1}$ and $x_c = 7.2$ person-Sv/reactor, where the minimum, mean and maximum are, respectively, 0.7, 6.2 and 18.8 person-Sv/reactor.

The variations of radioactive concentration must reflect some controlled or planned procedures. Those of foods contaminated by the Chernobyl accident but inspected in Japan, and those of contaminated metals due to the decommissioning of JPDR are examples of applicability of the hybrid scale.

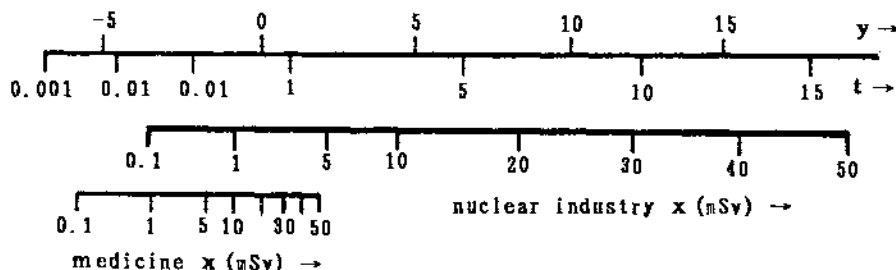

Figure 1 Examples of standard and actual hybrid scales

Another application of the hybrid scale is for the shouldered survival curves and low-LET radiation dose-response curves. The former is to plot surviving fractions on a hybrid scale with a positive parameter ρ estimated against doses on a linear scale⁴ and the latter is to plot effects on a log scale against doses on a hybrid scale with a positive parameter ρ^5 . These facts suggest to need new types of graph papers.

Figure 2 shows a hybrid hybrid paper which consists of both hybrid scales on a horizontal and on a vertical axis. A hybrid hybrid paper approaches a log log paper near the left lower corner of it, a section paper near the right upper corner, a semilog paper near the left upper corner or the right lower corner. In general a system of hybrid graphs is defined as follows:

(log linear)	(hybrid linear)	(linear linear)
(log hybrid)	(hybrid hybrid)	(linear hybrid)
(log log)	(hybrid log)	(linear log)

The key point of using the hybrid scale is to find an area, on a hybrid hybrid paper, with variations of the same order of magnitude in terms of y-value by selecting ρ parameters. Thus a way to implement a system of radiological protection must be to select a proper control space or area on a hybrid hybrid paper.

CONCLUSION

The hybrid scale has been developed to systematically formulate a quantitative feature of risks controlled by a system of radiological protection. However, as the hybrid scale is applicable for some biological effects of ionizing radiation but repaired by biological protection mechanisms, the hybrid scale is explicitly in future studies.

REFERENCES

1. Kumazawa, S. and Numakunai, T., 1981, A new theoretical analysis of occupational dose distributions indicating the effects of dose limits, *Health Physics*, 41, 465-475.
2. Kumazawa, S., 1987, Dose distribution models of workers (in Japanese), *J. At. Energy Soc. Jpn*, 29(11) 970-975.
3. Kumazawa, S. and Numakunai, T., 1991, Why do we need dose distribution models?, *Radiat. Prot. Dosim.*, 36(2-4), 269-273.
4. Kumazawa, S., 1991, A new model of shouldered survival curves, *Int. Biostatistics Conf. in the Study of Toxicology*, 5/23-25, 1991, Tokyo.
5. Kumazawa, S., 1992, Some hybrid scale models applicable for dose-response relationships, to be presented at the *Int. Conf. on Radiation Effects and Protection*, 3/18-20, 1992, Mito, Japan.

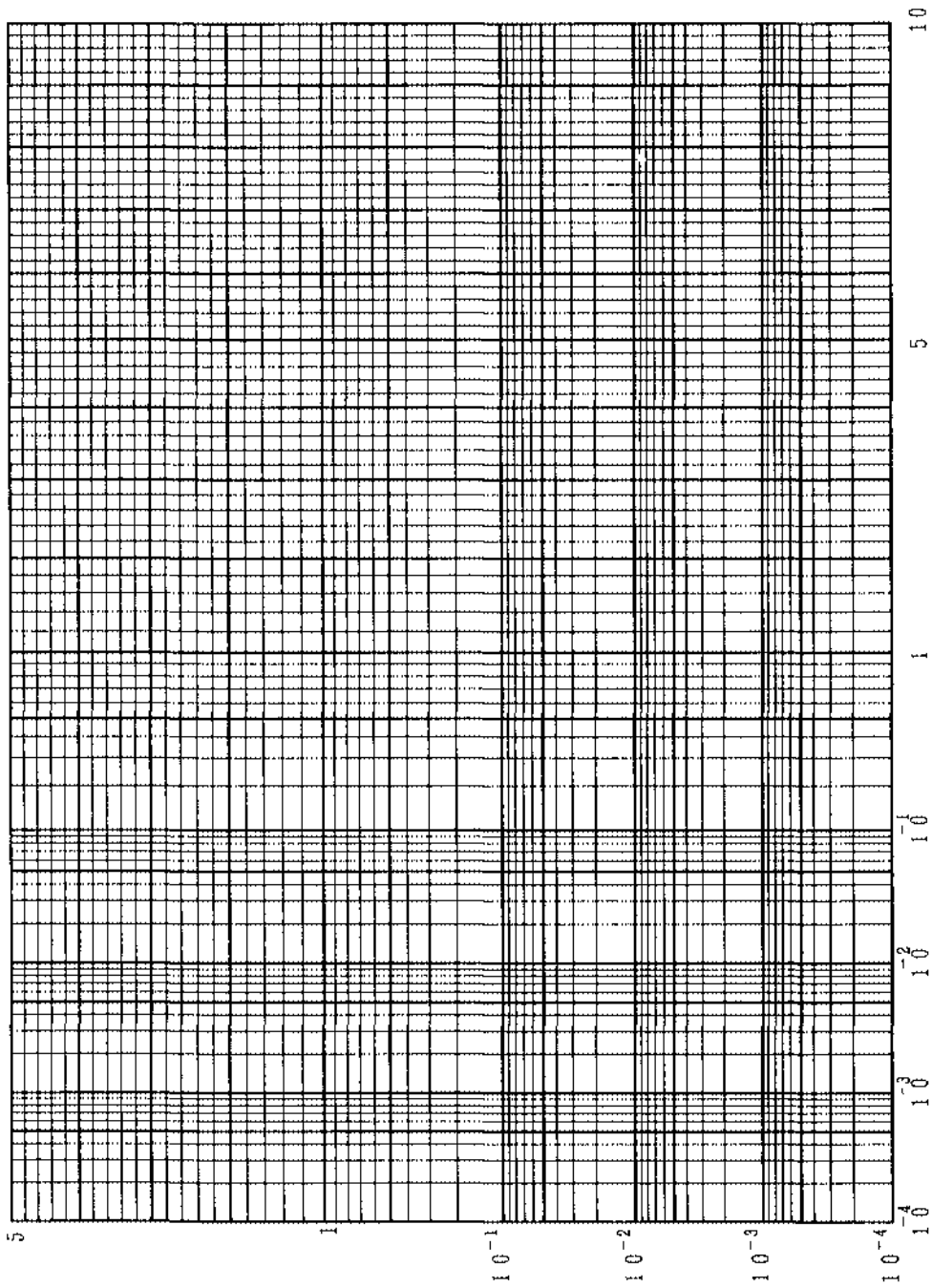

Figure 2. A hybrid hybrid paper

AN INTERIM UK RESPONSE TO REVISED RISK ESTIMATES AND ICRP 60

W P Bines and P F Beaver

Health and Safety Executive, London, UK

ABSTRACT

Risk estimates were revised in 1987. Since then, regulators have been under pressure to reduce dose limits. The UK government would prefer to await incorporation of ICRP's revised recommendations in a revision of the European Basic Safety Standards Directive. Interim action has therefore been taken, in the form of issuing additional guidance with a quasi statutory status. The new guidance includes the introduction of an investigation if an individual worker's cumulative dose within five years reaches or exceeds 75 mSv, to focus attention on workers being exposed at higher levels of dose.

BACKGROUND

The United Kingdom has had radiation protection legislation since the early 1960s, long before it joined the European Community. This legislation (Ref 1) only applied to the use of ionising radiation in factories however, licensed nuclear installations having radiological protection requirements written into their nuclear site licences; the remainder of users were covered by non-statutory guidance. Since joining the EC, the UK has fulfilled its obligation to implement the Euratom Basic Safety Standards Directive (Ref 2) by making the Ionising Radiations Regulations 1985 (Ref 3). These regulations extend radiation protection legislation to cover all uses and users of ionising radiation.

CURRENT LEGISLATION

The Ionising Radiations Regulations 1985, reflecting the Basic Safety Standards Directive, incorporate not only dose limits but, perhaps more importantly, the requirement for exposure to be kept as low as reasonably practicable (the UK equivalent of as low as reasonably achievable). The regulations contain certain action levels, which are levels of cumulative dose within a calendar year at which investigations must be made as a check on whether exposure is being kept as low as reasonably practicable. The first of these is when an individual's dose reaches 15 mSv. The ensuing investigation focusses on the work practices associated with this dose and whether it would be reasonably practicable to improve them to reduce exposure. The second

practicable to improve them to reduce exposure. The second action level is when a worker receives a dose of 30 mSv within a calendar quarter, in which case the enforcing authority, the Health and Safety Executive, must be informed.

DEVELOPMENTS SINCE 1987

The statement issued by ICRP following its meeting in Como in 1987 (Ref 4) recognised that further information about the Japanese atomic bomb survivors indicated that estimates of risk had been under-stated and should be considered to be two or three times as high as had previously been thought. As a result they would completely review their earlier recommendations, issued in 1977 (Ref 5). The UK National Radiological Protection Board, whose remit includes the duty to advise Government about the acceptability of international recommendations and standards, issued interim guidance in November 1987 (Ref 6). This guidance said that this latest information meant, in their opinion, that it would be prudent for employers to seek to restrict the exposure of their workers to no more than an average of 15 mSv a year over a number of years.

The Health and Safety Commission reacted to this advice from the National Radiological Protection Board by asking their recently appointed Working Group on Ionising Radiation to consider what action might be taken in view of the changing situation. The Working Group's subsequent advice (Ref 7) was that there was no need to reduce dose limits in advance of renegotiation of the Basic Safety Standards Directive, principally because the effect of the requirement to keep exposure as low as reasonably practicable had generally been to keep actual doses well below dose limits. However, they recommended that further statutory guidance on restriction of dose should be issued. This should draw employers' attention to the need to take account of the revised risk estimates when deciding whether existing and future exposures were as low as reasonably practicable, additionally it should focus attention on workers who were being exposed at an average of 15 mSv or more a year.

Following formal consultation with bodies and people likely to be affected by, and therefore interested in, the proposals (a statutory requirement in the UK's framework legislation for health and safety (Ref 8), further guidance was approved and published.

APPROVED CODE OF PRACTICE, PART 4

An Approved Code of Practice has a semi-legal status which is formally explained as follows "Although a failure to observe any provision of the Code is not in itself an offence, that

failure may be taken by a Court in criminal proceedings as proof that a person has contravened a regulation to which the provision relates. In such a case however it will be open to that person to satisfy the Court that the regulation has been complied with in some other way." Three Parts of an Approved Code of Practice supporting the Ionising Radiations Regulations 1985 had already been published, Parts 1 and 2 in 1985 (Ref 9) and Part 3, specifically about occupational exposure to radon, in 1988 (Ref 10).

Part 4, published in 1990 (Ref 11), advises employers to take account of the revised estimates of risk from exposure to ionising radiation when making new decisions about whether exposure is as low as reasonably practicable; it also requires them to review earlier decisions that are still operative to see if they remain valid in the light of the new information. Additionally the Code introduces an investigation if an individual worker's cumulative dose reaches or exceeds 75 mSv within any consecutive five calendar years. Unlike that when 15 mSv is reached within one year, this new investigation should focus on the individual's past dose history and likely future exposure. The final decision as to whether any further action needs to be taken to reduce the worker's future exposure should only be taken after the worker has been consulted and counselled and the views of other relevant people, such as the Appointed Doctor (an approved medical practitioner) and trade union and safety representatives, have been taken into account.

CONCLUSION

The issue of Approved Code of Practice Part 4 updates UK radiation protection to take account of revised risk estimates without changing dose limits. It also focusses attention on workers who have been receiving what is now seen as a relatively high level of dose in recent years, so that appropriate decisions to reduce their future incremental risk may be taken. This interim action will allow the UK to await revision of the Basic Safety Standards Directive before revising the dose limits and other provisions in our domestic legislation. The introduction of an investigation when 75 mSv or more is accumulated within five years is seen as compatible with ICRP '60 recommendations, in that it might quite properly be regarded as a generic constraint applicable to all users of ionising radiation.

REFERENCES

- 1 The Ionising Radiations (Unsealed Radioactive Substances) Regulations 1968, SI 1968 No. 780, and The Ionising Radiations (Sealed Sources) Regulations 1969, SI 1969 No. 808.
- 2 80/836/Euratom: Council Directive of 15 July 1980 amending the Directives laying down the basic safety standards for the health protection of the general public and workers against the danger of ionizing radiation. OJ L-246 of 17/09/80 page 1. Subsequently amended by 84/467/Euratom (OJ L-265 of 05/10/84 page 4).
- 3 The Ionising Radiations Regulations 1985, SI 1985 No. 1333, HMSO London.
- 4 International Commission on Radiological Protection, Statement from 1987 Como meeting. Radiol. Prot. Bull. No. 85 Supplement (1987).
- 5 International Commission on Radiological Protection, Recommendations of the ICRP, ICRP Publication 26, Annals of the Vol. 1 No. 3 1977, Pergamon Press.
- 6 National Radiological Protection Board, Interim Guidance on the Implications of recent Revisions of Risk Estimates and the ICRP 1987 Como Statement. Chilton, NRPB-GS9 (1987) (London HMSO).
- 7 Working Group on Ionising Radiations, Report 1987-88, Health and Safety Commission. HSE.
- 8 Health and Safety at Work etc. Act 1974. HMSO London.
- 9 Approved Code of Practice, Parts 1 and 2. The protection of persons against ionising radiation arising from any work activity. The Ionising Radiations Regulations 1985. HMSO.
- 10 Approved Code of Practice, Part 3. Exposure to Radon. The Ionising Radiations Regulations 1985. HMSO.
- 11 Approved Code of Practice, Part 4. Dose limitation - restriction of exposure. Additional guidance on regulation 6 of the Ionising Radiations Regulations 1985. HMSO.

TOWARDS UNIFORM STANDARDS OF RADIATION PROTECTION
IN HEALTH CARE IN EUROPE

P P Dendy

Dept of Medical Physics, Addenbrookes Hospital, Cambridge UK
(Chairman of the Professional, Education and Training Committee
of the European Federation of Organisations of Medical Physics)

ABSTRACT

In 1984 the Commission of the European Communities (CEC) issued a Directive for Protection of the Patient (84/466 Euratom). Article 5 of this Directive states that "A qualified expert in Radiophysics must be available to Sophisticated Departments of Radiotherapy and Nuclear Medicine".

This paper describes work carried out by the European Federation of Organisations of Medical Physics (EFOMP) on the interpretation and implementation of this Article.

INTRODUCTION

When Directives are issued by the Commission of the European Communities (CEC), Member States are required to introduce legislation, within a reasonable timescale, embodying the articles of the Directive. A Directive for Protection of the Patient (84/466 Euratom) issued in 1984 is specifically related to health care. Article 5 of this Directive states that "A qualified expert in radiophysics must be available to sophisticated departments of Radiotherapy and Nuclear Medicine" and to assist with the implementation of this Article, CEC Officers initiated a study to answer the following questions:

1. Do suitably qualified medical physicists, experts in radiophysics, exist in the Member States?
2. Are such experts available in radiotherapy, nuclear medicine and diagnostic radiology?
3. Is the basic education and training of the medical physicist in European Countries, a) consistent with the requirements of the proposed Directive of the Community on a general system for the recognition of higher education diplomas (89/48/EEC), b) equivalent in all countries, c) recognised by the appropriate government body?
4. What further education and hospital in-service training is required for the medical physicist to be designated as a qualified expert?

This paper reports on progress and developments resulting from the enquiry.

DESCRIPTION OF A QUALIFIED EXPERT IN RADIOPHYSICS (QE(R))

The first major problem was to define a QE(R). EFOMP has now proposed the following description:

"The Qualified Expert should normally be a suitably experienced physical scientist who would be responsible for the safe

application of radiological techniques in respect of the protection of the patient. This person would normally work in a hospital, or in a recognised analogous institution and would have knowledge and training in radiation physics appropriate to services where the quality of the diagnostic image or the precision of treatment is important and the doses delivered to patients undergoing these medical examinations or treatments must be strictly controlled"

This description has been accepted by the representatives of the National Authorities of Member States.

THE COMPETENCIES EXPECTED OF THE QE(R)

EFOMP is working towards a framework where 5 levels of competency will cover the whole of the career structure of the medical radiation physicist. A good honours degree or equivalent diploma in physics (competency level 1) will be followed by a period of training (competency level 2), then a period of experience. This will result in a qualified medical physicist (competency level 3) who will have an adequate span of practical knowledge, be able to perform given or routine professional tasks without supervision, and communicate with colleagues in related disciplines.

Because of the very advisory nature of the work of the QE(R), often requiring judgment in new or non-standard situations, EFOMP is now considering the view expressed by some Member Organisations that a further period of experience is required, to competency level 4, before becoming a QE(R). Competency level 5 would be appropriate for a Head of Department who was managing a range of routine services.

The duties and responsibilities of the medical radiation physicist in radiotherapy or nuclear medicine can now be assigned competency levels. The example in Table 1 is taken from draft proposals for a radiotherapy physicist.

**Table 1
Radiation protection - Source control**

Responsibility	Competency
a) Maintain source calibration certificates	2-3
b) Maintain records of contamination monitoring	3
c) Maintain source register with records of source purchase, movement and disposal	3
d) Assess adequacy of source storage facilities	2-3
e) Pack sources appropriately for transport with radiation hazard category and transport index correctly labelled	3
f) Arrange authorisation for waste disposal, by discharge to drains, incineration etc. as appropriate	2-3
g) Action to be taken in the event of source loss	2
h) Assessment of hazards and preparation of contingency plan for failure of teletherapy source return mechanism or fire	3-4

TRAINING FOR THE QE(R) IN THE VARIOUS EFOMP COUNTRIES

In 1984, EFOMP issued a policy statement on medical physics education and training¹ and more recently (1990) has conducted a survey of training programmes, with particular reference to training in radiation physics.

Replies have been received from 17 countries, 9 within the European Community and 8 outside it. All had introduced a training scheme in accordance with the EFOMP policy statement but 6 were not entirely happy with existing arrangements for the provision of lectures/seminars/tutorials and 4 felt that current arrangements for on-the-job practical training were unsatisfactory.

Current estimates of the number of physicists completing basic training with the approximate percentages in the ionising radiation related subject areas are shown in Table 2.

Table 2

Estimate of medical physicists completing training by country

<u>Country</u>	<u>Total</u>	<u>Percentage</u>				
		<u>Radthy</u>	<u>Nuc Med</u>	<u>Radlgy</u>	<u>Prot</u>	<u>Non Ion</u>
Belgium	0.5	80%	20%	-	-	-
Denmark	3-4	60%	20%	10%	-	-
France	30	40%	20%	20%	15%	5%
Germany	?					
Ireland	3-4	-	-	-	-	-
Netherlands	17	60%	-	20%	20%	-
Portugal	?					
Spain	8-10	50%	10%	20%	20%	-
UK	5-10	25%	25%	10%	-	40%
Austria	4	-	-	-	-	-
Czechoslovakia	8-10	60%	20%	20%	-	-
Finland	4	25%	25%	25%	-	25%
Norway	1-2	-	-	-	-	-
Poland	10-12	40%	30%	-	20%	10%
Sweden	10-20	-	-	-	-	-
Switzerland	1	-	-	-	-	-
Turkey	8	80%	15%	5%	-	-

EFOMP has also published, a policy statement on the training of a medical physicist as a QE(R)². In addition to the basic training covered in the previous policy statement, it recommends additional specialist training and a period of practical experience.

ADVANCED TRAINING BY EUROPEAN SUMMER SCHOOLS

With financial support from the European Community, the first Summer School for the QE(R) was held in Dublin in July 1991 to cover the advanced material required by the QE(R) in nuclear medicine. The school was very successful with 42 participants (6

lecturers, 2 observers, 5 associate lecturers/demonstrators and 29 students) from 17 different countries. Responses from the participants after the School showed that, in their opinion the objectives of the course were achieved. Following written and oral examination 16 persons were awarded EFOMP certificates of competence in the advanced course for training the QE(R).

INTERPRETATION OF THE TERM "SOPHISTICATED DEPARTMENT" IN ARTICLE 5

EFOMP has suggested that "Sophisticated Departments" should be those departments using ionising radiation routinely on patients, where complex equipment and/or complex procedures and/or frequent radiological examinations/treatments are involved. A meeting with Officers of the Commission in December 1991 acknowledged that this definition still contained subjective terms such as "complex procedures", but agreed that in any revision of the Directive the emphasis should be on the types of work undertaken.

EXTENSION TO DEPARTMENTS OF DIAGNOSTIC RADIOLOGY

Finally, representatives of National Medical Physics Organisations have argued strongly that diagnostic radiology should be included in Article 5. This is based on a number of factors - (i) the source of the highest radiation dose to the population is the use of X-rays in diagnosis, (ii) a number of complex high dose procedures are now in use, (iii) surveys have shown a wide range of doses for the same examination, (iv) the need for proper training of radiologists. Representatives of National Authorities are currently less supportive, some on the basis that the case of need has not been adequately demonstrated, some on grounds of cost and some because a significant proportion of the work is already covered by radiation protection services.

CONCLUSION

EFOMP has already been able to make a significant input to the thinking of Officers of the CEC on the right way to provide medical radiation physics support for the proper protection of the patient. More work remains to be done but an important route of communication from medical physics staff in hospitals through National Organisations of Medical Physics and EFOMP to the Commission has been established.

REFERENCES

1. EFOMP Policy Statement (1984). Medical physics education and training: The present European level and recommendations for its future development.
2. EFOMP Policy Statement (1988). Radiation protection of the patient in Europe: The training of the Medical physicist as a Qualified Expert in Radiophysics.

ref: stdinrp.doc/23 January 1992

AN IN VITRO INVESTIGATION ON THE SUBCELLULAR EFFECTS OF 50 HERTZ MAGNETIC FIELDS

W. Malorni, S. Paradisi, E. Straface, M.T. Santini,
and G. Donelli.

Dept. of Ultrastructures, Istituto Superiore di Sanita',
Viale Regina Elena 299, 00161 Rome Italy

ABSTRACT

The effects of 50 Hz ELF electromagnetic fields were investigated in cultured cells using morphological, ultrastructural and cytological techniques. Experiments conducted at different values of exposure intensity (2.5, 5 and 10 mT) and duration (from 24 to 96 hours) demonstrated that these fields seem to modify slightly surface morphology and intercellular relationships without affecting cell reproductive integrity.

INTRODUCTION

In recent years, much interest and debate have developed concerning the possible health risks to humans from exposure to extremely low frequency (ELF) electromagnetic fields (50-60 Hz) originating from a wide variety of sources (power transmission lines, household electric wiring and appliances, etc.). Results from numerous studies conducted *in vitro* have elucidated possible effects of these ELF fields on cells. However, although it has been hypothesized that specific organelles could be targets for electromagnetic radiation and consequently impair cell function (1-6), the mechanisms of action of these fields as well as the health risks to humans still remain unclear. The above considerations together with the controversial nature of the results themselves (2-4), prompted us to study the effects of ELF fields on cultured epithelial cells. Particular attention was paid to the proliferative capability and morphological features of these cells.

MATERIALS AND METHODS

Cell cultures: A431 cells (a human carcinoma cell line) were grown in DMEM supplemented with 10% fetal calf serum, non-essential aminoacids, 5mM L-glutamine, 100 I.U./ml penicillin and 100 ug/ml streptomycin.

Exposure system: The experimental set up was described previously (7). Briefly, homogeneous sinusoidal 50 Hz magnetic fields were generated inside cylindrical coils 50 cm in height and 15 cm in diameter. Electric current densities of up to 24 A circulating in about 300 loops generated different magnetic flux densities. Flasks containing A431 cells were inserted in the center of the coils with the monolayer oriented parallel with respect to

the magnetic field. The magnetic flux density was measured directly at the sample position through the narrow Hall probe of a Namicon MP-U 10/84 gaussmeter. Accuracy of the measurements was $\approx 2\%$. Temperature inside the coils was monitored continuously and kept at 37 ± 0.1 °C. Flasks inside the coils with no current were considered as controls (sham-exposed).

Cell treatments: ELF field intensities used in these experiments were 2.5, 5, 10 mT. Treatments lasted 24, 48, 72 or 96 hours.

Cell growth curves: 2×10^5 cells were seeded with 5ml of fresh medium in culture flasks. The flasks were filled with a 5% CO₂-air gas mixture and kept in the exposure system. Control cells were sham-exposed in the same temperature-controlled coil as experimental A431 cells. Cell counts were made at the end of each of the exposure times in triplicate using a Coulter Counter (Coulter Electronics, Ltd., Luton, England).

Scanning Electron Microscopy (SEM): For scanning electron microscopy cells were grown on glass coverslips. Sham-exposed and exposed cells were fixed with 2.5% glutaraldehyde in 0.1 M cacodylate buffer (pH 7.4) at room temperature for 20 min. Following post-fixation in 1% osmium tetroxide for 30 min, cells were dehydrated through graded ethanols, critical point dried in CO₂ and gold coated by sputtering. The samples were examined with a Cambridge 360 scanning electron microscope.

Fluorescence microscopy: Control and treated cells grown on coverslips were fixed with 3.7% formaldehyde in phosphate buffered saline (PBS) for 10 min. at room temperature. After washing in the same buffer, the cells were permeabilized with 0.5% Triton X-100 (Sigma) in PBS for 5 min. Cells were stained with fluorescein-phalloidin (Sigma) at 37 C for 30 min. After thorough washing, the samples were mounted together with glycerol-PBS (1:1) and observed with a Nikon optiphot fluorescence microscope.

RESULTS

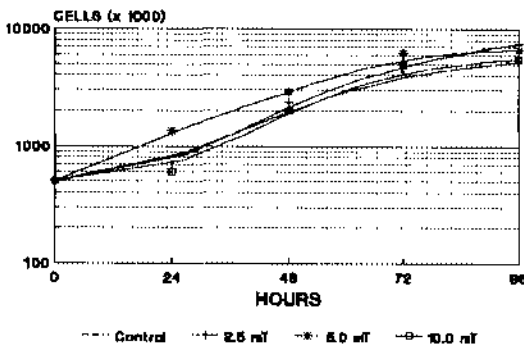

Growth curves. The effect of ELF fields on A431 cell growth is represented on the left (Fig. 1). No statistically significant differences were detectable in the growth rates of sham-exposed cells and cells exposed up to 96 hours to 2.5, 5 and 10 mT.

SEM analysis. In Fig. 2a the surface morphological features of control A431 cells are shown. Exposure to a 5 mT ELF field for 24 hours seems to induce flattening of the cell

cytoplasm accompanied by a rearrangement and redistribution of microvillar structures (Fig. 2b). After 48 hours of treatment, the above-mentioned modifications were also accompanied by an alteration of intercellular contacts. However, despite these changes monolayer confluence was nonetheless observed (Fig. 2c).

Fluorescence microscopy. The actin microfilament network appeared to be modified slightly by 5mT ELF fields. In particular, with respect to control cells (Fig. 3a), a marginalization of F-actin filaments toward the cell periphery occurred after 24 hours of exposure (Fig. 3b). Furthermore, after 48 hours, a microfilament rearrangement characteristic of cell retraction as well as intercellular contact modifications were observed (Fig. 3c)

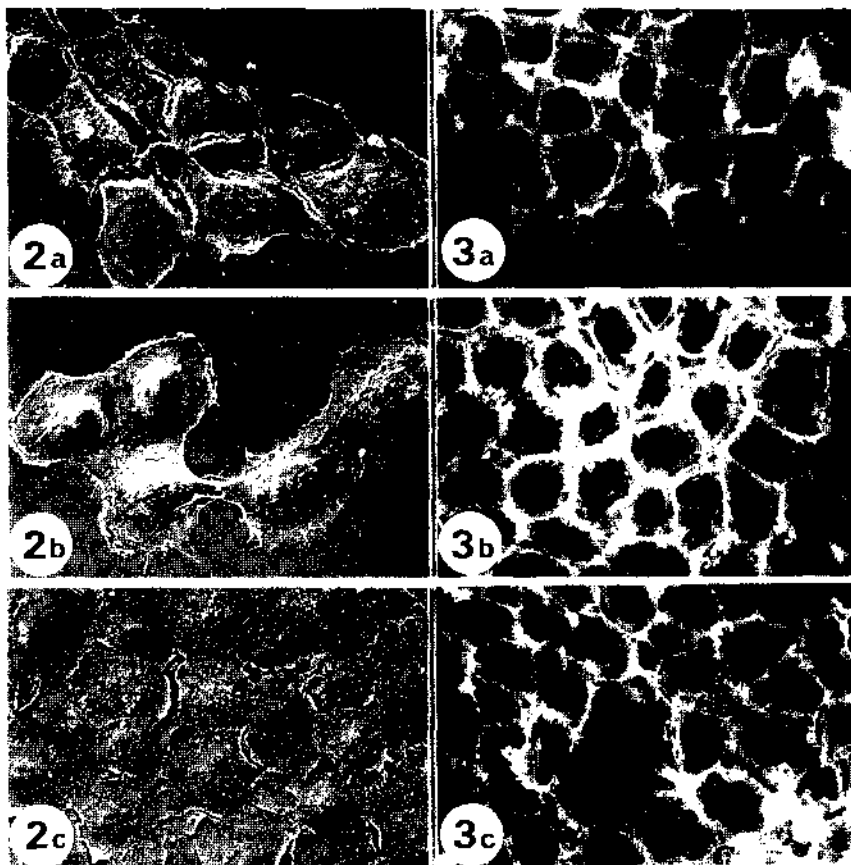

DISCUSSION

Our data suggest that sinusoidal magnetic fields can alter epithelial cell plasma membrane structure without modifying cell proliferative ability. These data can be paralleled with those of Adey (5, 8) which showed that magnetic fields can reduce the integrity of cell-to-cell contacts without interfering with other subcellular

processes. Furthermore, recent data from our group on chick embryo myoblasts revealed that cell membrane conductivity and permittivity can be affected by exposure to ELF fields (7). In contrast to the previously hypothesized role of ELF fields in promoting rather than initiating tumor development (9,10), our results seem to indicate that proliferative features of A431 cells are not affected by ELF field exposure. This fact could be related to differences in exposure conditions or to the type of cells used. Moreover, "window" effects render any speculation on this matter even more difficult (1).

This study was supported by the CNR-ENEL Project - Interaction of energy systems with human health environment - Rome, Italy.

REFERENCES

1. Goodman, R and Shirley-Henderson, A, 1990, Exposure of cells to extremely low-frequency electromagnetic fields: relationship to malignancy? *Cancer Cell*, 2, pp.355-359.
2. Phillips, JL, Winters, WD, and Rutledge, L, 1986, In *vitro* exposure to electromagnetic fields: changes in tumour cell properties. *Int. J. Radiat. Biol.*, 49, pp.463-469.
3. Ross, SM, 1990, Combined DC and ELF magnetic fields can alter cell proliferation. *Bioelectromagn.*, 11, pp.27-36.
4. Livingston, GK, Witt, KL, Gandhi, OP, Chatterjee, I and Roti Roti, JL, 1991, Reproductive integrity of mammalian cells exposed to power frequency electromagnetic fields. *Environ. Mol. Mutag.*, 17, pp.49-58.
5. Adey, WR and Sheppard, A, 1987, Cell surface ionic phenomena in transmembrane signaling to intracellular enzyme systems. In Blank M, Findl E (eds): "Mechanistic Approaches to Interactions of Electromagnetic Fields with Living Systems" Plenum Press, New York pp.365-387.
6. Aoki, H, Yamazaki, H, Yoshino, T, and Akagi, T, 1990, Effects of static magnetic fields on membrane permeability of a cultured cell line. *Res. Comm. Chem. Pathol. Pharmacol.*, 1, pp.103-106.
7. Grandolfo, M, Santini, MT, Vecchia, P, Bonincontro, A, Cametti, C and Indovina, P, 1991, Non linear dependence of the dielectric properties of chick embryo myoblast membranes exposed to a sinusoidal 50 Hz magnetic field. *Int. J. Radiat. Biol.*, 60, pp.877-890.
8. Adey, WR, 1981, Tissue interactions with non ionizing electromagnetic fields. *Physiol. Rev.*, 61, pp.435-514.
9. Cohen, MM, Kunska, A, Astemborski, JA, McCulloch, D and Paskewitz, DA, 1986, Effect of low-level, 60-Hz electromagnetic fields on human lymphoid cells: I. Mitotic rate and chromosome breakage in human peripheral lymphocytes. *Bioelectromagnetics*, 7, pp. 415-423.
10. Rosenthal, M and Obe, G, 1989, Effects of 50-Hz electromagnetic fields on proliferation and on chromosomal alterations in human peripheral lymphocytes untreated or treated with chemical mutagens. *Mutat. Res.*, 210, pp. 329-335.

THE WORK OF COMMITTEE 4 OF ICRP

Roger H Clarke

National Radiological Protection Board,
Chilton, Oxon, UK

ABSTRACT

This paper explains the rôle of Committee 4 of ICRP and outlines its current programme of work with the associated timescales. The topic areas are: probabilistic exposures; radiological emergencies; and radon at home and in the workplace.

INTRODUCTION

Committee 4 of the International Commission on Radiological Protection is established to consider the practical application of the Commission's Recommendations. The current programme of work of Committee 4 ICRP has now been running for three years and was established as the new Recommendations of the Commission were nearing completion. The programme therefore focused on three major issues that were emerging and would not be resolved by the time the new Recommendations were published. The Commission endorsed the Committees proposals for work in these three areas and has appointed a Task Group for each.

The first topic relates to the introduction of **potential exposures** in Publication 60. The Commission gives suggests that risk limits are not to be set and proposes **risk constraints** be developed but no guidance is given on how this is to be done.

The second topic is **intervention for protection of the public in a radiological emergency**. The Commission last gave advice in Publication 40 which was prior to the Chernobyl accident. There is a need to update the principles in the light of experiences gained in the intervening years.

The third topic being considered by Committee 4 is **Measures for protection against radon**. This was the last of the topics to be identified and the relevant Task Group has been in existence for a shorter period than the other two. The main thrust of the work relates to the establishment of intervention levels for radon in homes and in the workplace. The terms of reference specifically exclude radon in mines. However, the Commission accepted a recommendation of Committee 4 that it should clarify its position with regard to occupational exposure in mines. It has set up a Task Group of the Main Commission with the intention that the situation should be resolved in a relatively short time.

The work of each of the three Task Groups is considered in turn. The status of the work is as of mid-1991 in this paper. All of the Task Groups will be meeting and producing amended drafts for the next Committee 4 meeting in April 1992. An update of the progress will be given in the presentation at the IRPA meeting.

TASK GROUP ON THE ASSESSMENT AND CONTROL OF RISK FROM POTENTIAL EXPOSURES

This Task Group is chaired by Richard Cunningham of the US Nuclear Regulatory Commission and has as members, Adolf Birkhofer (Germany), Abel Gonzalez (IAEA), Lars Hoeberg (Sweden), and Bert Winkler (South Africa).

Potential exposures may arise from the introduction of any practice and may involve a wide range of consequences. Some practices utilise simple sources and the consequences of accidents may be fairly limited in terms of the numbers of people and areas affected. This may apply to the failure of

interlocks on an irradiation facility, or an accident involving an industrial radiography source. Other practices lead to a complex series of "source terms", such as nuclear installations, where the consequences of an accident may range from the almost negligible to significant social and economic disruption as well as severe health effects. Other effects may arise in the far future such as those from the deep disposal of solid radioactive waste.

The Commission has recommended that a risk limit should not be set on the grounds that it is impossible to regulate such a limit. On the other hand it is feasible to set constraints which may be sequence specific depending on the type of practice. The Task Group is considering generalised constraints on probabilistic events along the following lines:

- (a) events which result in doses below the dose limits and are treated as part of normal exposure: 10^{-1} to 10^{-2} y^{-1}
- (b) events which result in doses above the dose limits but are stochastic in nature: 10^{-2} to $10^{-6} y^{-1}$
- (c) events where some radiation effects are deterministic, but not fatal: 10^{-5} to $10^{-9} y^{-1}$
- (d) events when early death is likely: $< 10^{-7} y^{-1}$

These figures are intended to illustrate the types of constraint that may be imposed based on judgements of what can be accomplished and could be revised in the light of operational experience gained.

One of the more difficult issues for the Task Group is to try to recommend levels of probability that are sufficiently low as to make the event acceptable, regardless of the consequences. The acceptable level depends on whether the consideration is of justification, optimisation or individual risk.

In justifying a practice involving potential exposure there are many considerations other than radiological consequences and some events will be accepted, even if they are severe, because of the benefits expected from the practice. This will lead to a natural acceptance of some low probability events. In deciding on the optimisation of the safety of a particular plant, there will be an aggregation of various attributes for the purpose of comparing alternatives. In this case some sequences will not contribute significantly to the aggregated "risk" from the plant and may be ignored. These sequences may be of relatively high probability, but of little consequence, or may be of high consequence, but with negligible contribution to the "risk". In either case there is reason to accept events without further attempt to reduce their probabilities. Finally there will be grounds for accepting an event when the individual health risk is low enough. There are reasons for thinking that a risk of death to an individual of less than $10^{-7} y^{-1}$ is so low as not to be of concern to the individual.

The work of this Task Group will be of importance to the nuclear safety community as well as to the radiological protection world. However the report must not be written so as to appear dominated by nuclear power, since more accidents occur in the industrial and medical fields.

TASK GROUP ON PRINCIPLES FOR INTERVENTION FOR PROTECTION OF THE PUBLIC IN A RADIOLOGICAL EMERGENCY

This Task Group is chaired by Roger Berry of British Nuclear Fuels and has as members: Larry Channey (Canada), Frances Fry (UK), Yuri Konstantinov (USSR), Guy Lamaire (France), and Anneli Salo (Finland).

This Task Group is applying the principles of ICRP 60 for INTERVENTION. These are:

- (a) The proposed intervention should do more good than harm, i.e. the reduction in detriment resulting from the reduction in dose should be sufficient to justify the harm and costs, including social costs, of the intervention (JUSTIFICATION)

- (b) The form, scale, and duration of the intervention should be optimised so that the net benefit of the reduction in dose, i.e. the benefit of the reduction in radiation detriment, less the detriment associated with the intervention, should be maximised (OPTIMISATION)

Dose limits do not apply in the case of intervention, but Publication 60 states that the application of principles (a) and (b) will lead to dose levels where intervention is appropriate. The major objectives of the work of the Task Group are to develop the techniques of optimisation to be applied to each specific countermeasure. This should help clarify the difference in using individual or collective dose as the variable in the optimisation depending on the countermeasure. It is clear that an optimisation may lead to there still being no net benefit. The optimisation process is most likely to lead to a dose within a range of doses between which the intervention is justified. The Task Group is planning to use the justification principle to derive levels of dose, well below those at which deterministic effects would be observed, at which intervention is almost always likely to be justified. The resulting intervention levels are shown in Table 1.

There will thus be no lower levels of doses below which the Task Group recommends that intervention is not warranted because of the difficulties in finding common values which apply across a wide range of individual and societal benefits and disadvantages. It still remains clear that the dose limits for normal operation of the practice are not necessarily the correct figures at which to start intervention, although intervention below dose limits must be unjustified.

Table 1

Levels of individual dose at which intervention is almost certain to be warranted

Protective Action	Quantity	Intervention Level (mSv)
Sheltering	Effective Dose	50
Evacuation	Effective Dose	500
	Skin Dose	5000
Stable Iodine	Thyroid	500
Food Control	Effective Dose	10
Relocation	Effective Dose	Dependent on circumstances

The report will not address the exposure of emergency workers, either those who are involved in the immediate action to control the event, or those who become exposed as a result of the deliberate programme of decontamination. The Task Group will give guidance for the restriction of exposures for those people whose work takes place in a contaminated environment as a result of an accident, but whose work would not otherwise involve radiation exposure.

TASK GROUP ON MEASURES FOR PROTECTION AGAINST RADON

This Task Group is chaired by Richard Osborne (Canada) with members: John Harley (USA), Tony James (USA), Mike O'Riordan (UK), Gun-Astrid Swedjemark (Sweden), and Pierre Zettwoog (France).

The report addresses the situation of radon in dwellings first as that is the area where intervention as described by ICRP is most easily understood. The principles are identical to those referred to above and in this case everyone appears to be quite clear that dose limits for practices do not apply. The Commission has previously given advice in this area, but since then two things have happened. First the risk estimates have increased and second, more importantly, there is a new model of the human respiratory tract under development by a Task Group of Committee 2 of ICRP. This new model gives doses per unit intake that are at present 2 or 3 times greater than those given by the present

lung model. The reasons are that the new model identifies the secretory cells on the bronchi as being the cells at risk rather than the deeper basal cells previously thought to be those at risk. This increases the dose per Bq inhaled. In addition the model apportions the w_T of 0.12 for the lung in the ratio of the natural incidence of lung cancers. These are smoking related, and occur in the major bronchi which leads to a greater weighting being placed on the dose to those bronchi. The Commission has asked its Committee 1 (Biological Effects) to advise on the two features of the new model. The outcome will be of major significance to the work on radon.

The report will deal with the physical and biological fundamentals as well as movement and measurement, followed by remedial and preventive measures.

The more difficult area is the workplace. There will be situations where there is a high radon level in a workplace and intervention may be indicated, but are the workers to be regarded as occupationally exposed with all the associated considerations of monitoring, record keeping and medical examinations. The Commission has rather left this to National Authorities in Publication 60. If that Authority declares that a workplace is affected by radon, then the workers are radiation workers. The Task Group is trying to develop guidance which would help the decision making. Two possible approaches are being considered:

- (a) only that exposure to radon that is increased above the general level in the area is regarded as occupational exposure and this additional exposure is subject to control;
- (b) where the worker is not involved with handling radioactive materials and the additional exposure to radon is not considered occupational exposure.

The first proposal would treat radon as artificial radiation sources are treated in that natural background radiation is excluded from that for which management has responsibility. The second proposal means that radon at work would be dealt with in exactly the same way as radon at home and intervention alone would apply.

CONCLUSIONS

The three Task Groups of Committee 4 are meeting during the autumn of 1991 and will produce new texts for the Committee 4 meeting in April 1992. The intention is that Committee 4 will submit those three reports after any corrections and amendments, to the Main Commission at its meeting in November 1992. If the Commission adopts any or all of the reports, they should appear in the Annals early in 1993.

EDF-GDF
Directions Générales
Service des Etudes Médicales

CHAMPS ELECTRIQUES ET MAGNETIQUES ET CANCERS :
EXISTE-T-IL UNE RELATION ?

L'enquête épidémiologique d'Electricité de France

LAMBROZO J.¹ - GUENEL P.² - GOLDBERG M.² - CHEVALIER A.³ -
IMBERNON E.⁴ - HUTZLER B.⁵ - WARRET G.⁴ - DAB W.¹

ELECTROMAGNETIC FIELDS AND CANCERS : IS THERE A RELATIONSHIP ?
THE EPIDEMIOLOGICAL STUDY OF ELECTRICITE DE FRANCE

Electricité de France, Hydro-Québec and Ontario-Hydro are put together to grant a nested case-control study regarding possible effects of occupational exposure to EMF. Outcomes of interest are various cancers (leukaemia, brain tumor, melanoma). The cohort consists of 20 000 thousand electricity utilities male workers. Cases (4 controls for each case) were collected from an occupational cancer register.

A subset of 1 000 subjects underwent EMF dosimetry (POSITRON dosimeters).

A job-exposure matrix was also set up in order to assess concurrent exposures to potentially carcinogenic chemical as classified by IARC.

Results are expected to be published by the end of 1992. The study is coordinated by the Pr G. THERIAULT (Mac Gill University).

L'éventualité d'une relation entre l'exposition aux champs électriques et magnétiques de très basse fréquence (50-60 Hz) et la survenue de certains types de cancers demeure une question très controversée, malgré l'importance des travaux épidémiologiques et biologiques qui y sont consacrés.

Electricité de France s'est associée à ONTARIO-HYDRO et à HYDRO-QUEBEC pour entreprendre une étude épidémiologique en milieu professionnel visant à apporter des éléments de réponse.

-
1. Service des Etudes Médicales EDF-GDF - 22-30, avenue de Wagram - 75382 PARIS CEDEX 08
 2. INSERM U 88 - 91, Boulevard de l'Hôpital - 75634 PARIS CEDEX 13
 3. Service Général de Médecine de Contrôle EDF-GDF
 4. Service Général de Médecine du Travail EDF-GDF
 5. Direction des Etudes et Recherches EDF - Les Renardières, route de Sens, Ecuelles - 77250 MORET-SUR-LOING

Nous présentons ici les principales modalités de l'étude pour sa partie française. Elle ne diffère pas d'ailleurs fondamentalement dans sa composante canadienne.

LA POPULATION

Il s'agit d'une enquête cas-témoins au sein d'une population de 120 000 travailleurs.

- Les cas :

Le critère d'inclusion est la survenue d'un cancer chez les travailleurs statutaires en activité, de sexe masculin, entre janvier 1978 et décembre 1989. Les données sont recueillies dans un registre professionnel des cancers.

Pendant cette période 2075 cas de cancer ont été dénombrés. Les leucémies sont au nombre de 74. Les mélanomes cutanés sont au nombre de 39 cas. Enfin 90 tumeurs cérébrales ont été dénombrées.

L'incidence des tumeurs malignes tous types confondus dans la population considérée et pendant la période de recueil (12 ans) est en moyenne de 138 cas pour 100 000.

- Les témoins :

Les témoins sont tirés au sort. Il s'agit de travailleurs de sexe masculin, nés la même année que les cas auxquels ils sont appariés, présents depuis au moins un an dans l'entreprise à la date du diagnostic. Il a été sélectionné 4 témoins par cas.

- L'historique de carrière :

Le fichier du personnel permet, pour chaque cas et chaque témoin, de décrire l'ensemble des postes occupés dans l'entreprise depuis l'embauche jusqu'à la date du diagnostic.

L'EXPOSITION PROFESSIONNELLE

Elle comprend deux volets, l'exposition aux champs électromagnétiques mesurée par dosimétrie et celle aux autres facteurs potentiellement cancérigènes.

L'évaluation individuelle des expositions est assurée par une matrice emploi/exposition.

- La dosimétrie :

La dosimétrie est assurée par des dosimètres POSITRON mesurant le champ électrique et le champ magnétique dans la fréquence considérée (50 Hz). Les mesures sont stockées dans 16 cases d'amplitude dont la première enregistre les valeurs $< 0,0031 \mu\text{T}$ pour les champs magnétiques et pour le champ électrique, entre 2,4 V/m et 40 kV/m.

Le dosimètre est porté par l'agent pendant une semaine, accroché à sa ceinture, pendant toute la journée de travail, mais aussi en dehors de l'activité professionnelle, lors des loisirs ou à son domicile. Pendant le sommeil, il est posé en lieu "neutre", à distance d'appareils et d'installations électriques, mais toujours à la même place pendant la semaine de dosimétrie.

Il est demandé aux agents, de remplir en parallèle une fiche d'activité, où est mentionnée l'heure du lever, les heures de travail et les tâches effectuées pendant cette période (lieu de travail, voltage, travail sous tension ou hors tension...). La fiche d'activité prend en compte également les activités de loisir et l'heure du coucher.

Pour chaque agent, le dosimètre enregistre toutes les minutes, une mesure de champ électrique et une mesure de champ magnétique. Les données sont ensuite traitées par logiciel, qui permet d'établir des histogrammes. Il est également établi un bilan hebdomadaire d'exposition, où figurent en particulier la dose totale, la valeur moyenne et l'historique de l'exposition. Il est possible de séparer l'exposition purement professionnelle de l'exposition totale.

La campagne de dosimétrie a concerné environ 1 000 travailleurs, qui se répartissent dans les différentes branches d'activités de l'entreprise. Les travailleurs ont été sélectionnés pour représenter les principaux métiers pouvant entraîner une exposition aux champs. Des sujets non exposés ont également été inclus dans l'échantillon.

Actuellement nous ne disposons encore que de données partielles. Il ressort cependant une différence nette entre les sujets professionnellement exposés et ceux n'ayant qu'une exposition de base. A titre d'exemple, les ouvriers d'entretien des postes ont une exposition moyennée hebdomadaire de 2,6 μ T, les monteurs souterrains 0,7 μ T, le niveau moyen des "non-exposés" étant de 0,14 μ T. Il s'agit de données qui ne portent que sur 600 dosimétries et qui sont susceptibles de modifications, lorsque l'ensemble des données viendra à être disponible. Il faut également remarquer que certaines activités, dans le groupe des exposés, ne diffèrent pas quant à leur dosimétrie, du groupe des non exposés, il s'agit des agents de petites interventions.

- La matrice emploi-exposition pour les facteurs de confusion

Outre l'exposition aux champs électriques et magnétiques, la matrice emploi-exposition permet d'évaluer, pour les emplois existants ou ayant existé à EDF, l'exposition à d'autres produits potentiellement cancérigènes des liste 1, 2A et 2B du Centre International de Recherche sur le Cancer, et bien sûr, utilisés dans l'entreprise.

Il s'agit donc d'une évaluation des expositions moyennes attachées aux métiers exercés à EDF.

Les colonnes correspondent aux expositions professionnelles et les lignes correspondent aux emplois. A l'intersection des lignes et des colonnes, sont notés le niveaux moyens d'exposition définis selon l'intensité, la fréquence, la durée, et la probabilité de l'exposition.

Il en résulte une définition individuelle pour chaque sujet inclus dans l'étude de son niveau d'exposition, dans les différents emplois exposés.

L'établissement d'une matrice emploi-exposition est une approche pragmatique pour apprécier quantitativement des expositions dans les différents postes de travail. Elle n'est cependant pas exempte de limites. Il a été nécessaire de regrouper les fonctions occupées car la définition initiale à EDF était de 1 321 fonctions auxquelles s'ajoutaient 650 codes de spécialités.

Le regroupement a permis de définir une série de "métiers", mais ces métiers étant eux-mêmes évolutifs, avec souvent une modification du mode opératoire ou limitation de l'exposition ou l'utilisation de procédés de protection efficace, il a été nécessaire de définir des "métiers périodes". L'exemple du plomb est à ce type démonstratif : l'exposition au plomb a notablement décru depuis 1975 où les conduites neuves sont en polyéthylène, les niveaux d'exposition ont été définis en 4 échelons :

- exposition égale à la population générale
- exposition supérieure à la population mais inférieure à la VME
- exposition élevée variant entre le niveau de la VME et 3 VME
- exposition très élevée supérieur à 3 VME.

LE CALENDRIER DE L'ETUDE

- Le recueil de l'ensemble des données a été complété fin mars 1991
- Leur analyse pendant plusieurs mois et les premiers résultats seront disponibles vers la fin de l'année 1992.

HEALTH EFFECTS OF ELECTRIC AND MAGNETIC FIELDS:
PROGRESS AND NEW DIRECTIONS

Maria A. Stuchly

Department of Electrical and Computer Engineering
University of Victoria
Victoria, British Columbia, V8W 3P6

ABSTRACT

For decades there has been a scientific interest in interactions of electric, magnetic and electromagnetic fields with biological systems. Most of research and interest in the last few years have been in the area of extremely low frequency fields. Research of biological effects of electromagnetic fields is complex, comprising many areas, and it usually requires an interdisciplinary approach. Two distinctive, if sometimes overlapping, streams of studies have been conducted; one concerned with effects that may detrimentally affect human health, and the other exploring properties of electromagnetic fields for medical purposes, in either diagnostic or therapeutic applications. A brief overview is given here of the main directions in this field, progress and unresolved problems, and current directions of the research.

INTRODUCTION

Areas of research can be broadly divided into four categories, as illustrated in Figure 1. Measurements and dosimetry, and interaction mechanisms, provide an integral support in both the assessment of health effects and medical applications. The appreciation of the role of measurements and dosimetry in biological experimentation during the last two decades has brought a remarkable progress in quantification of biological effects and in development of exposure standards at radiofrequencies (RF) [1,2]. Dosimetry and interaction mechanisms provide important links between studies performed on various levels of organization of biological systems and the ultimate goal of determination of risks to the human health or therapeutic medical treatment, as illustrated in Figure 2. The importance of such an integrated approach has become particularly apparent in the research of biological effects of fields at extremely low frequencies, ELF, (1-300 Hz).

In contrast to early studies in bioelectromagnetics, which were mostly of exploratory nature, frequently only qualitative in assessment and often subject to artifacts, current studies are in many cases conducted by interdisciplinary teams. These studies include a careful characterization of exposure conditions, dosimetric evaluation where possible, and a meticulous control of artifacts. Many of the studies are aimed at testing and extending specific hypotheses [3]. Starting in the eighties the main research effort has been at ELF. Research activities and knowledge in bioelectromagnetics are too vast and diverse for a comprehensive overview, therefore, the remarks that follow are only a selected glimpse at some of the areas.

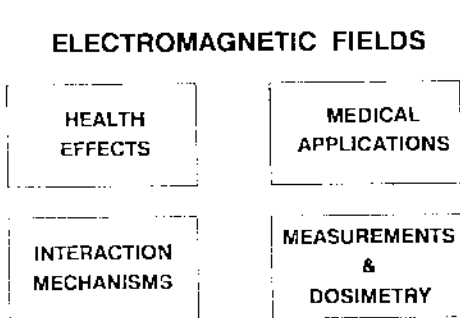

Figure 1

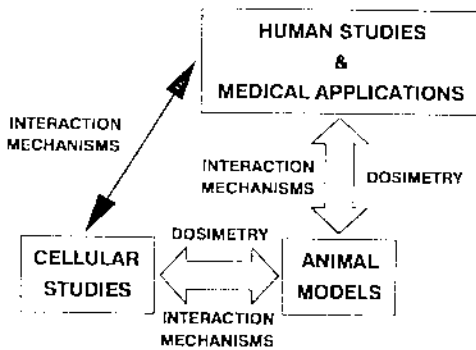

Figure 2

EXPOSURE ASSESSMENT

Measurements of electromagnetic exposure fields are of fundamental importance in many aspects of bioelectromagnetics. In experiments with cell preparations, animals and human volunteers, it is very important that exposure fields are comprehensively and accurately determined. Similarly, in medical applications, where it is important that either the exposure field or the electric field induced in the treated tissue have well defined specific characteristics, accurate measurements of fields are essential. Epidemiological studies have only a limited value, unless they include exposure assessment through actual measurements or other well-based quantitative methods. Finally, only through reliable measurements or estimation of exposure fields can compliance with exposure standards be ensured and protection against over-exposures implemented.

Exposure assessment at ELF and in particular at power line frequencies (50 or 60 Hz) is an area of a currently active pursuit. This is particularly important in support of epidemiological studies. A number of sophisticated personal dosimeters have been developed for this purpose [4]. One of the problems in this area is that the existing biological data do not clearly indicate what dosimetric parameters are of importance in eliciting interactions. Some studies suggest that the waveform, or perhaps transients or changes are important, which would indicate that measurements extending beyond the amplitudes of the electric and magnetic fields might be required.

Measurements of transient fields and pulsed electric and magnetic fields have recently become of growing interest, as there is a need to assess exposures associated with the electromagnetic pulse (EMP), as well as many other exposure situations such as large switching current at switchyards and transformer stations, arc-welding, induction heating, and RF heating. Several novel active and electro-optical sensors and measurement techniques have been recently developed [5,6].

DOSIMETRY

For ELF electric and magnetic fields dosimetric measures have

not yet been established. Although induced current densities from exposure to these fields have been calculated and can be measured [7,8], at present there is no compelling evidence that the current density in tissue is the critical dosimetric measure. Perhaps, calculations of current densities and induced potentials on the microscopic (subcellular) level will prove useful when used in conjunction with biophysical models of interactions.

HEALTH EFFECTS

Most of the studies conducted with ELF fields, are at the power line frequencies (50 and 60 Hz) [9]. A number of studies are motivated by beneficial effects of exposure rather than a potential hazard. These studies often utilize complex waveforms with energy contained below 1000 Hz. Magnetic fields are more often used rather than electric fields. The on-going investigations can be divided into three groups: (1) human studies, (2) animal studies, and (3) in vitro studies.

On-going human studies are mostly epidemiological and concerned with cancer [10]. Environmental exposures of children to electric and magnetic fields at 50 or 60 Hz are being scrutinized for a possible association with childhood cancers, particularly leukaemia and brain cancer. Epidemiological assessment is also underway for various occupational groups that are more exposed to electromagnetic fields than workers in other occupational groups. What distinguishes these studies from a number of already published studies is that actual measurements of exposure are performed, if only on the sample basis. In these studies, personal dosimeters are used for a certain period of time (e.g. 48 h) to determine an average exposure of the studied cohorts to electric and magnetic fields. Usually, current studies also have more statistical power than the previous studies, and some are prospective rather than retrospective. A very interesting human study with volunteers looks at effects on cardiovascular and nervous system responses [11]. This study is characterized by careful dosimetry, as well as elimination of artifacts.

To elucidate the question of a possible association between exposure to ELF fields and cancer, a number of animal studies have been undertaken. Long-term chronic studies which encompass an animal lifespan are presently underway and include lymphoma development in mice, brain cancer in rats, liver cancer in mice and skin cancer in mice. In some of these studies, a specific cancer is initiated (with a chemical agent or ionizing radiation) and the investigations are aimed at determining whether the field acts as a promoter. Also short-term studies looking at specific interaction mechanisms (e.g. melatonin suppression, or copromotion) have been undertaken.

The number of cellular in-vitro studies in progress is relatively large, many of them focused on a biological interaction mechanism. There appears to be a better convergence among the studies undertaken by researchers concerned mostly with potential hazards from environmental, occupational or medical exposures and those who are primarily interested in beneficial uses of ELF fields.

Conclusions

Interactions of electromagnetic fields with biological systems have been a subject of scientific inquiry for quite a long time. There are many common features of studies of potentially hazardous health effects and of studies of medical applications. At present there appears to be better appreciation of this fact and considerable cross-fertilization. Another positive characteristic of many investigations today is that they are aimed not only at the identification of an effect, but that they explore testable hypotheses in search of interaction mechanisms.

REFERENCES

- [1] Biological Effects and Exposure Criteria for Radiofrequency Electromagnetic Fields. National Council on Radiation Protection and Measurements, Report No. 86, Bethesda, MD, U.S.A. (1986).
- [2] Stuchly, M.A., 1987, Proposed Revision of the Canadian Recommendations on Radiofrequency Exposure Protection, Health Physics, 53, 649-665.
- [3] Adey, A.W., 1988, Cell Membranes: the Electromagnetic Environment and Cancer Promotion, Neurochem. Res., 13, 671-677.
- [4] Renew, D.C., Male, J.C. and Maddock, B.G., 1990, Power-Frequency Magnetic Fields: Measurement and Exposure Assessment. CIGRE Congress Record, Publ. No. 36-105.
- [5] Thansandote, A., Stuchly, S.S. and Stuchly, M.A., 1991, Broadband Active E-Field Sensors for Measurement of Transients, IEEE Trans. Instrum. Meas., 40, 465-468.
- [6] Stuchly, M.A., LePoche, H., Gibbons, D. and Thansandote, A., 1991, Active Magnetic Field Sensor for Measurements of Transients, IEEE Trans. Electromagn. Compat., in press.
- [7] Kaune, W.T. and Gillis, M.F., 1981, General Properties of Interaction Between Animals and ELF Electric Fields, Bioelectromagnetics 2, 1-11.
- [8] Tenforde, T.S. and Kaune, W.T., 1987, Interaction of Extremely Low Frequency Electric and Magnetic Fields with Humans, Health Physics, 53, 585-606.
- [9] Nair, I., Morgan, M.G. and Florig, H.K., 1989, Biological Effects of Power Frequency Electric and Magnetic Fields, U.S. Congress, Office of Technology Assessment, OTA-BP-E-59.
- [10] Savitz, D., Pearce, N.E. and Poole, C., 1989, Methodological Issues in Epidemiology of Electromagnetic Fields and Cancer, Epidem. Rev., 11, 59-64.
- [11] Graham, C., Cohen, H.D. and Cook, M.R., 1990, Immunological and Biochemical Effects of 60-Hz Electric and Magnetic Fields in Humans, Midwest Research Institute Report No. RA-338-C.

"HYPERSENSITIVITY TO ELECTRICITY" - A WORKPLACE PHENOMENON RELATED TO LOW-FREQUENCY ELECTRIC AND MAGNETIC FIELDS

B. Knave, U. Bergqvist and R. Wibom

National Institute of Occupational Health
S-171 84 Solna (Stockholm), Sweden

ABSTRACT

The present study describes the symptoms in "hypersensitivity to electricity" on basis of the medical histories of 32 afflicted people. Thirty-one of the 32 subjects (97%) reported vague skin complaints, such as blotchiness, pinkness, reddening, itching etc. Twenty subjects (63%) reported symptoms from the nervous system, such as dizziness, fatigue, headache, sweating, depression, heart palpitations, memory lapses etc. There were no symptoms indicative of organic lesions of the nervous system. The symptoms, however, were often pronounced and resulted in sickness registration in 25% of the cases. Twenty-nine of the 32 subjects (91%) cited the VDU as the triggering factor, but other triggering factors were also mentioned: fluorescent lighting, sunlight, electrical devices and wiring, ventilation units etc. Discontinuing VDU work was the most frequent adopted measure and the method achieving the greatest symptom alleviation.

INTRODUCTION

In the 1980's a number of studies have attempted to determine whether work at video display units (VDU's) was capable of producing certain slight and otherwise commonplace skin symptoms and disorders (see the tabulation in WHO Offset Publication No. 99, 1987; Knave et al., 1985; Lidén and Wahlberg, 1985; Svensson and Svensson, 1987; Berg and Lidén, 1990.) These studies consistently found that certain subjective skin complaints did increase in VDU work, but clinical diagnoses failed to find any equivalent increase in objective findings.

Over the past 4-5 years, attention has also turned to a small group of people (primarily VDU users) reporting more pronounced problems, usually in combination with other symptoms from e.g. the nervous system, sensory organs, upper respiratory tract, gastrointestinal tract etc. The complaints were not solely related to VDU's. The proximity of electrical wiring indoors and outdoors, electrical machines and devices, fluorescent lighting etc, have been reported to be triggering factors. Many people in this group are heavily affected and have been officially registered as ill for long periods of time. The patients have coined the term "hypersensitivity to electricity," since they feel that the proximity of electrical equipment, devices and wiring is a least common denominator. They recently founded the "Association for People Injured by VDU Work and Electricity," an organization in Sweden which now has about 1300 members.

The objectives of the present study were to report on and tabulate subjective symptoms in "hypersensitivity to electricity." The medical histories of 32 people reporting this hypersensitivity served as the basis of the tabulation.

METHOD AND MATERIAL

Each subject's medical history was taken by one of us (BK) and the information obtained was systematically tabulated and analysed. Thirty-two (32) people participated in the study. They were recruited in three different ways:

- Ten were selected at random from members of the "Association for People Injured by VDU Work and Electricity" resident in the Stockholm area (group A).
- Employees of the National Telecommunications Administration, referred to us by the Administration's central Occupational Environment Unit. The first 10 employees (living in different parts of Sweden) in this category were selected (group B).
- Twelve people were referred to us in some other way, primarily from local occupational health & safety services (group C).

Eleven of the 32 subjects (34%) were men, and 21 (66%) were women. The mean age of the men was 37 (range 20-61) years, and the mean age of the women was 41 (range 21-60) years. At the time they were afflicted, 20 of the 32 subjects (62%) worked as secretaries, telephonists, VDU operators with routine duties etc., whereas 12 (38%) worked as economists, engineers, managers etc.

SUMMARY OF RESULTS AND DISCUSSION

Symptoms and symptom prevalence. Thirty-one of the 32 subjects (97%) reported diffuse skin complaints, such as a rosy and reddened skin, hot, warm and burning sensations, pain, itching etc. Twenty persons (63%) reported functional symptoms from the nervous system, such as dizziness, tingling, fatigue, weakness, headache, difficulty in breathing, sweating, depression, heart palpitations, memory lapses etc. There were no symptoms indicative of any organic lesions of the nervous system. Seventeen of the 32 subjects (53%) also reported symptoms from eyes and vision, which did not, however, distinguish this group from other groups of VDU-users.

Initial and predominant symptoms. For 19 of the 32 subjects (59%), skin complaints were the first symptoms of "hypersensitivity to electricity". For 10 subjects (31%) and 7 subjects (22%), symptoms from the nervous system and the eyes respectively were the first symptoms detected. There was a similar distribution of the predominant groups of initial symptoms: skin symptoms were most common (63%), followed by symptoms from the nervous system (41%). Other groups of symptoms displayed a much lower prevalence.

Course of illness. The disorder proved to be of strikingly recent date; 25% fell ill in 1988, 60% in 1986 or later and 85% in 1983 or later. More than 60% of the subjects had symptoms which remained unchanged or became progressive after onset. Illness symptoms were often pronounced and resulted in official illness registration in 25% of the cases.

Triggering factors. Twenty-nine of the 32 subjects (91%) cited the VDU as the triggering factor in current symptoms. Other triggering factors ultimately developed (fluorescent lighting, electrical devices and wiring, ventilation units, cars, trains, sunlight etc.). The high proportion of VDU users in the material may have been due to various selective mechanisms. As a result of the current public debate on VDU's, symptomatic VDU workers may have been selected to the study more readily than symptomatic people with no VDU work duties. The temporal link between symptoms and VDU work (e.g. in the development of skin symptoms after an employee switched to a different VDU) may be more informative in this context.

Effects of certain countermeasures. The effect of adopted countermeasures appeared to depend on the type of symptoms displayed. When a person only had skin symptoms, she/he had a good chance of improving. But when symptoms were from the nervous system, the adopted counter-measures failed to produce any improvements. The present study was unable to ascertain the reason for this discrepancy. "Hypersensitivity to electricity" may consist of different sub-components, some of which possibly more resistant to therapy than others.

Discontinuing VDU work was the most common and even the most effective symptom-alleviating measure. However, switching to a low-emission VDU usually did not result in any improvement. On the contrary, several cases of deterioration were noted.

Comparisons between recruitment groups

The different recruiting methods probably enabled different selection mechanisms to affect the composition of the sub-groups. In group B (with the smallest percentage of symptoms from the nervous system, the smallest percentage of symptoms in general and with a more favourable recovery), subjects were all working full-time. This was in contrast to group A in which most of the subjects were registered as ill. People with moderate symptoms were often able to continue working, despite their symptoms.

It may be that the Telecom Administration employees in group B represented an "early" stage of "hypersensitivity to electricity," whereas people "injured by electricity and VDU work" in group A may have represented a later stage in development of that disorder. Or the people in groups A and B may have actually represented two different symptomatologies.

Skin symptoms and symptoms from the nervous systems. Despite the limited

scope of our study, some differences in the material were discernible in respect to skin symptoms and nervous system symptoms. People with these two symptom categories differed in e.g. age and sex distribution, possible triggering factors, the efficacy of remedial measures and prognosis (see Table 1.)

Table 1. Differences between subject groups with skin symptoms and nervous system symptoms in the studied group"

Condition	Skin symptoms	Nervous system symptoms
Age variation	None	Increased with age
Symptoms from a VDU	Rapid symptom onset more common	Onset usually insidious
Symptom when switching to a different VDU	Occurred in some cases	Did not occur
Symptoms from electrical equipment	Uncommon	More common
Treatability	Most improved	Few improved
Prognosis	Relatively good	Relatively poor

REFERENCES

Berg M. and Lidén S. (1990). Skin complaints and VDU work: An epidemiological study. In "Work With Display Units 89", ed by Berlinguet L and Berthelette D. North-Holland, Elsevier Science Publishers B.V., Amsterdam, pp 181-188.

Knave B., Wibom R., Voss M., Hedström L. and Bergqvist U. (1985). Work with video display terminals among office employees. I. Subjective symptoms and discomfort. Scand J Work Environ Health 11, 457-466.

Lidén C. and Wahlberg J. (1985). Work with video display terminals among office employees. V. Dermatologic factors. Scand J Work Environ Health 11, 489-493.

Svensson E. and Svensson J. (1987). Long-term VDU Work resulted in moderate skin complaints + tendency to increase during winter-time (in Swedish). Läkartidningen 84; pp. 1843-1845.

WHO Offset Publication No. 99 (1987). Visual display terminals and workers' health. World Health Organization, Geneva.

An Approach To Tackle Visual Display Unit User Health Problems

H.M. McCallum and B. Heaton,

Department of Bio-medical Physics, Aberdeen Royal Infirmary, Foresterhill,
Aberdeen AB9 2ZD, SCOTLAND.

Abstract

Reported health hazards from video display units (VDUs) vary from headaches to miscarriage and there is some concern that health problems experienced by VDU users could be associated with extra-low-frequency (ELF) electromagnetic field emissions. While investigating an individual case of 'VDU Syndrome' a procedure was developed which could be used to investigate and evaluate other complaints of a similar type. A relationship between the number of hours monitor work and severity of symptoms was observed along with a cyclic nature to the operator's sensitivity to VDU work.

Introduction

There is much public concern over the possible health hazards of ELF magnetic fields, especially amongst those who may be occupationally exposed. Working with video display units has been linked with health problems from eyestrain to miscarriage. Two studies published in 1988 found a significant risk of spontaneous abortion in women who worked more than 15 hours a week at a VDU (McDonald et al, 1988) and more than 20 hours VDU work per week (Goldhaber et al, 1988). However these studies did not measure the electromagnetic fields which were suggested to be harmful. A recent study by Schnorr et al (1991) measured both extra-low-frequency (45-60 Hz) and very-low-frequency (15kHz) electromagnetic fields around a sample of VDUs. This study concluded that the use of VDUs and exposure to accompanying electromagnetic fields were not associated with an increased risk of spontaneous abortion. However, VDU operator anxiety continues along with reports of eyestrain and headaches, as shown in a well controlled study (Rossignol et al, 1987) which found an increased prevalence of adverse conditions related to vision, musculoskeletal discomfort and headaches amongst clerical workers who used VDUs.

The data presented in this paper were gathered during a six month survey on the health of an individual VDU operator who suffered from severe headaches, nausea and eyestrain.

Methods

The VDU operator who was suffering from health problems was given a health questionnaire to quantify the range, severity and frequency of her health complaints. The questionnaire listed a short range of symptoms e.g. sore eyes, headache, nausea, which she was asked to grade daily on a scale of 0 to 4 where 0 corresponded to an absence of symptom and 4 extremely severe discomfort. The number of hours worked at a VDU were also noted.

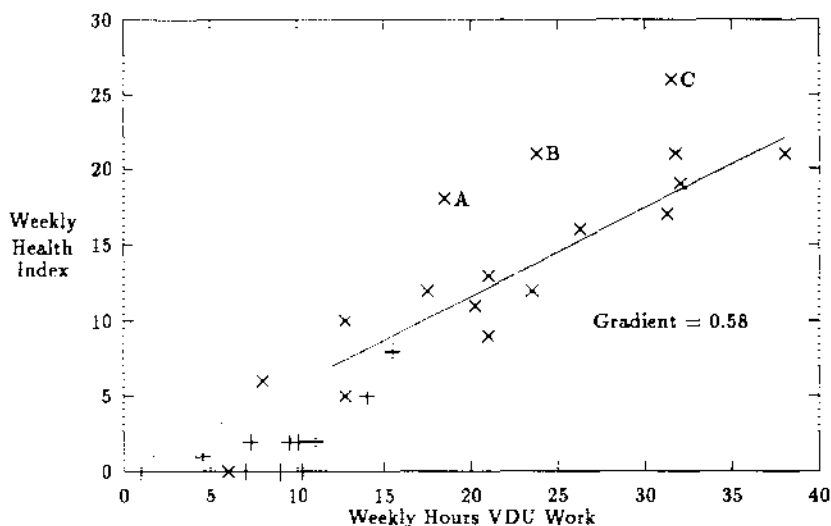

Figure 1: Weekly Health Index against Weekly Hours VDU Work:
 × - initial 3 month survey period, + - final three month survey period

The health of the VDU operator was monitored initially for three months whilst in a VDU intensive post and then for a further three months whilst in a post requiring significantly fewer hours VDU work, although the work was carried out on the same monitor.

Results

From the health survey data, the total hours worked at a VDU and the total of symptom gradings, defined as the weekly health index, were calculated for each week. Figure 1 shows a plot of weekly health index against weekly hours VDU work. A clear dose-response relationship was found, which is probably a personal characteristic. The survey showed that the effects of VDU work seemed to accumulate during a week's work; symptoms worsening towards the end of a week with complete recovery during weekends. If the total weekly VDU hours worked was more than 13, then the weekly health index was directly proportional to the number of VDU hours worked in that week. When the total was less than 13, the relationship was less clear, but the data suggests a threshold at approximately 7 hours, below which little or no adverse health effects were experienced.

As can be seen from Figure 1, points A, B and C lie significantly above the dose-response curve, indicating a particularly sensitive week where the stated number of hours VDU work caused much greater discomfort than might be expected. To investigate this further, a sensitivity index was defined as:

$$\text{Sensitivity} = \frac{\text{Weekly Health Index}}{\text{Weekly Hours VDU Work}}$$

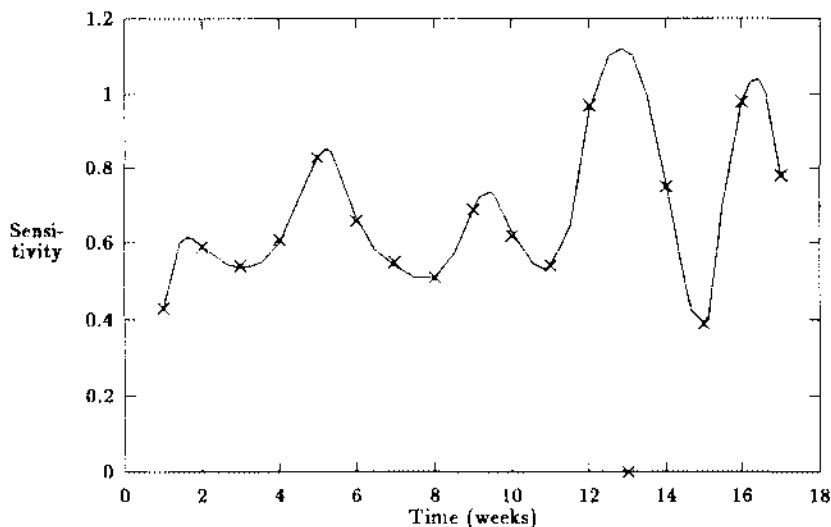

Figure 2: Sensitivity against Time

Figure 2 shows how Sensitivity varies with time. The graph shows a distinct cyclic quality which has an average period of 26 days.

Discussion

Whilst investigating an individual VDU operator suffering from severe headaches, nausea and eyestrain, a clear personal dose-response relationship was found which was a straight line fit when there were more than 13 VDU hours worked in one week. Excluding the three high sensitivity points, the data have a surprisingly small spread, indicating that the health problems seemed to be associated with VDU work and not some other work task. During the initial 3 month survey period, the following ergonomic changes were made in an attempt to reduce discomfort:

- half of the overhead fluorescent lighting was removed to reduce brightness and dazzle,
- screens were positioned behind the operator to eliminate glare, and
- fluorescent lighting was replaced with tungsten lamps to alter the quality of the light.

The workstation was already of a high standard, with a grounded anti-static mesh fitted over the monitor screen, and no significant improvements could be introduced. Although the operator felt more comfortable after these changes, this was not reflected in her health gradings which continued to be high enough to reduce her productivity and at times require sick-leave. When the operator's tasks were altered to require fewer hours VDU work, a significant improvement in health was observed, and the data obtained during this period suggests a shoulder to the dose-response curve with a threshold at approximately 7 hours. The variation of sensitivity with time was investigated during the initial survey period only,

and revealed a cyclic nature with a mean period of 26 days. This relationship may suggest a possible hormonal link and although stress is a possible explanation, this seems unlikely since the high sensitivity points are distributed throughout the range of weekly VDU hours and high stress might be indicated if these points were all due to a high number of weekly hours VDU work.

Any case of VDU user health problems could be tackled in a similar way. By filling in a daily health questionnaire, both the sufferer and employer are able to gauge the severity of the symptoms, and grading symptoms numerically discourages an emotional response. If ergonomic improvements can be made, or alterations in working practice, then a lessening of severity of symptoms would be reflected in the health gradings over a period of time.

This case study of VDU health problems has yielded interesting results, which were consistent throughout an extended survey period. However this is only one case and the symptoms of some other cases have been successfully relieved by altering the workstation design or using the ergonomic changes described earlier. Further research is required to determine whether a high sensitivity group of VDU workers exists, and if so, what factors influence their health symptoms. One such study is being carried out in Aberdeen.

References

- Goldhaber M.K., Poien M.R. and Hiatt R.A.
The Risk of Miscarriage and Birth Defects Among Women Who Use Visual Display Units During Pregnancy.
Am. J. Med. (1988), 13; 695-706.
- McDonald A.D., McDonald J.C., Armstrong B. et al.
Work with Visual Display Units in Pregnancy.
Br. J. Ind. Med. (1988), 45; 509-15.
- Rossignol A.M., Morse E.P., Summers V.M. et al.
Video Display Terminal Use and Reported Health Symptoms Among Massachusetts Clerical Workers.
J. Occ. Med. (1987), 29;2;112-18.
- Schnorr T.M., Grajewski B.A., Hornung R.W. et al.
Video Display Terminals and the Risk of Spontaneous Abortion.
New Eng. J. Med. (1991),324:11;727-733.

ETUDE DE L'EXPRESSION DES ONCOGENES DANS DES FIBROBLASTES HUMAINS
APRES IRRADIATION AVEC UN LASER A IMPULSIONS TRES BREVES

D. Dormont^{1,2}, Th. Fréville², H. Raoul¹, D. Courant¹ et L. Court²

¹ Commissariat à l'Energie Atomique, DSV-DPTE, Bp6, 92260 Fontenay aux
Roses, France. ² Centre de Recherches du Service de Santé des Armées,
Bp87, 38702 La Tronche, France.

STUDY OF THE ONCOGENIC EXPRESSION IN HUMAN FIBROBLAST CELLS
AFTER EXPOSURE TO VERY SHORT PULSED LASER RADIATIONS.

The aim of this study is to evaluate the capacity of a laser, delivering very short pulses in the near infrared spectrum with a high pulse ratio frequency, to induce genetic modification on biological tissues. The absence of dicentric among chromosomal aberrations on human lymphocytes suggests that a repetitive very short pulses irradiation has a relatively low capacity to induce genetic abnormalities. The studies of the radiation effects on the cellular growth and the oncogenic expression show that the modifications, induced at the cellular level, do not seem the origin of a cellular transformation and a possible mechanism of carcinogenesis.

INTRODUCTION

Les études antérieures, conduites dans le but de protéger le personnel exposé, ont montré que l'irradiation par un laser, délivrant des impulsions très brèves ($<10^{-8}$ s), peut induire des effets cytogénétiques sur des lymphocytes du sang circulant. Ces effets sont essentiellement caractérisés par une augmentation des fragments chromosomiques [1]. L'absence de dicentriques suggère que ce mode d'irradiation par impulsions brèves présente, par rapport aux autres modes d'irradiation [2, 3, 4, 5], une capacité à induire des anomalies génétiques relativement faible. Pour confirmer cette hypothèse, nous sommes convenus d'étudier d'une part, les effets biologiques du faisceau sur la croissance cellulaire et d'autre part, l'expression oncogène après exposition au même faisceau. Ceci permet d'apprécier, à un niveau moléculaire, si les altérations susceptibles d'être induites par un tel rayonnement peuvent être à l'origine d'une transformation et d'un mécanisme de cancérogénèse.

MOYENS ET METHODES

Le laser utilisé dans l'étude émet à 1064 nm et la durée de l'impulsion est de 50 ns. La variation d'énergie est obtenue en faisant varier la durée du train d'impulsions. Deux niveaux extrêmes d'énergie sont étudiés, 25 mJ et 250 mJ. L'irradiation s'effectue sur des cellules trypsinisées, recueillies dans un tube conique de 10 ml après centrifugation et aspiration du milieu de culture. Parallèlement des fibroblastes humains non irradiés ont été manipulés dans les mêmes conditions.

Les cellules étudiées sont des fibroblastes de poumon embryonnaire humain (IGI G7). Les cellules ne clonent pas en agar mou et ne sont pas tumorigènes chez la souris athymique. Les cultures cellulaires s'effectuent à 37°C en atmosphère humide contenant 7 % de CO₂ dans du milieu d'Eagle modifié additionné de pénicilline (25 U/ml) de streptomycine (25 mg/ml) et supplémenté avec 10 % de serum de veau fœtal.

Vingt-quatre et soixante-douze heures après l'irradiation les cellules ont été lavées au PBS et les ARN cellulaires ont été préparés selon la méthode de Chirgwin et Coll. Les cellules ont été lysées par addition de thiocyanate de guanidium 5.5 M et les ARN ont été purifiés par centrifugation. Les culots ont été dissous puis les ARN ont été précipités à l'éthanol en présence de 200 mM d'acétate de sodium. Après centrifugation les précipités ont été lavés à l'éthanol 70%, séchés et redissous dans de l'eau stérile. Les ARN ont été quantifiés par mesure de la densité optique à 260 nm et leur qualité a été vérifiée par une électrophorèse.

RESULTATS

1. Etude de l'effet d'un faisceau laser sur la croissance cellulaire

Des boîtes de culture ont étéensemencées avec $7 \cdot 10^4$ fibroblastes irradiés à 25 mJ ou 250 mJ ou non irradiés.

- Les fibroblastes non irradiés ont, en phase exponentielle de croissance, un temps de doublement de l'ordre de 35 heures. L'inhibition de contact est atteinte au 6ème jour avec une densité moyenne de $4,7 \cdot 10^5$ cellules par boîte correspondant à une densité de saturation d'environ $4,9 \cdot 10^4$ cellules par cm².
- Après irradiation, on note d'une part un allongement du temps de doublement (délai respectivement égal à 55 et 48 heures) et une réduction de la densité de saturation celle-ci atteignant au 6ème jour respectivement $3,5 \cdot 10^4$ et $3,4 \cdot 10^4$ cellules par cm². Les deux courbes de croissance de cellules irradiées à 25 et 250 mJ sont globalement superposables suggérant ainsi qu'il n'existe pas d'effet-dose à l'intérieur de cette gamme de doses (Fig 1).

2. Etude de l'expression oncogène après irradiation laser

a. Analyse qualitative de l'expression des oncogènes:

La première étape de cette étude a été de déterminer quels étaient les oncogènes qui s'exprimaient normalement dans nos conditions expérimentales et ceux qui s'expriment après irradiation laser. Dans ce but 1 µg des oncogènes suivants: v-abl, c-erbA1, c-erbB2, c-fes, v-fms, c-mos, c-myb, c-myc, L-myc, N-myc, c-raf, c-Ha-ras, c-Ki-ras, N-ras, c-ros, c-src, c-src2, c-sis, c-ycs, et p53 ont été déposés sur des filtres de nitrocellulose. Après rinçage des filtres à l'acétate d'ammonium 2 M les acides nucléiques ont été fixés.

Les filtres ont été hybridés avec des sondes cADN préparées à partir

de ARN de cellules irradiées ou non irradiées. Cette technique a permis de montrer que les fibroblastes non irradiés exprimaient dans nos conditions expérimentales à un niveau notable les oncogènes *C-myc*, *c-raf*, *c-erbB1* et *c-Ha-ras*. Vingt-quatre et soixante-douze heures après l'irradiation les mêmes oncogènes sont exprimés par les cellules irradiées. L'irradiation n'induit donc pas l'expression d'autres oncogènes.

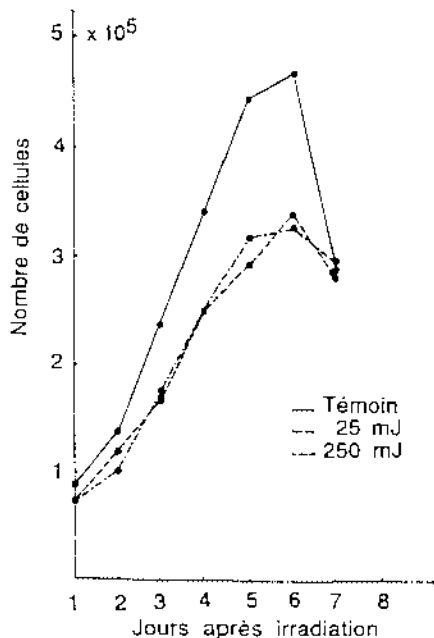

Figure 1: Effets du faisceau laser (1064 nm) sur la croissance des fibroblastes humains embryonnaires. Les doses de 25 et 250 mJ correspondent à des expositions respectives de 16 et 128 impulsions de 50 ns délivrées avec une fréquence d'émission de 1kHz.

b. Analyse quantitative de l'expression des oncogènes:

Afin de comparer le niveau d'expression des oncogènes détectables en dotblot entre les cellules irradiées et non irradiées, les ARN ont été analysés selon la technique Northern. Le marquage des sondes a été effectué par translation de coupure. Leur activité spécifique était comprise entre 1 et 2.10^8 cpm/ μ g.

L'hybridation des filtres avec une sonde dérivant d'un fragment de l'oncogène *c-myc* humain (correspondant au 3ème exon) a révélé une forte expression de *c-myc* dans les cellules irradiées à 16 et 170 mJ, 24h après

leur irradiation mais identique à celle des cellules humaines non irradiées. Soixante-douze heures après l'irradiation le niveau d'expression de c-myc diminue significativement dans les cellules irradiées et non irradiées, cette diminution traduisant très probablement l'arrivée au stade de confluence cellulaire.

L'hybridation des filtres avec une sonde dérivant de l'oncogène raf cloné dans pSP65 n'a pas révélé de différence significative entre les cellules irradiées et non irradiées.

L'hybridation des filtres avec une sonde dérivant du récepteur humain à l'EGF cloné dans pUC12 n'a objectivé aucune différence de niveau d'expression entre les cellules irradiées et non irradiées.

L'hybridation des filtres avec une sonde dérivant du gène EJ-ras s'est heurtée à des problèmes de cross hybridation entre l'oncogène et l'ARN ribosomique 28S ce qui interdit d'interpréter les résultats. Il semble donc indispensable de refaire des Northern en utilisant non plus de l'ARN cellulaire total mais de l'ARN polyA+, ce qui nécessite l'irradiation d'un nombre élevé de cellules. Ces manipulations sont actuellement en cours.

CONCLUSION

Il apparaît que Les fibroblastes de poumon humain embryonnaire présentent après irradiation un allongement du temps de doublement et une réduction de la densité de saturation. Il n'existe pas d'effet-dose à l'intérieur de la gamme de doses étudiées. Dans les limites de nos conditions expérimentales, l'irradiation des fibroblastes humains par un faisceau laser ne modifie pas la gamme des oncogènes normalement exprimés, leur niveau d'expression et leur régulation en fonction de leur croissance. L'étude de l'oncogène Ha-ras nécessite en raison de problèmes techniques une analyse plus fine des ARN messagers des cellules irradiées.

BIBLIOGRAPHIE

1. Guedeney G., Courant D., Dormont D. et Court L., 1990. Effets cytogénétiques d'un laser Nd:YAG impulsif sur des lymphocytes humains, S.S.A. Trav. Scient., 11, 165-166.
2. Rounds D.E., Chamberlain E.C. and Okigaki T., 1964, Laser radiation of tissue cultures. Ann. N.Y. Acad. Sci., 122, 713-727.
3. Paul J.S., Zugola R.C., Fong P.A. and Kop M.J., 1970, Laser-induced changes in DNA synthesis and embryonic developments in sea urchins. Exp. Cell Res., 60, 166-174.
4. Berns M.W. and Cheng W.K., 1971, Chromosome lesions produced with argon laser microbeam without dye sensitization. Science, 171, 903-905.
5. Nakajima M., Fukuda M., Kavoki T. and Atsumi K., 1983, Cytogenetic effects of argon laser irradiation on chinese hamster cells. Radiation Res., 93, 598-600.

EVALUATION DES EFFETS CYTOGENETIQUES D'UN RAYONNEMENT
LASER A IMPULSIONS TRES BREVES

G. Guedeney¹, D.Courant¹, J-L Malarbet², M-T Dolloy² et L. Court³

¹ Commissariat à l'Energie Atomique, DSV-DPTE, ² IPSN-D2HD, Bp 6, 92260 Fontenay aux Roses France, ³ Centre de Recherches du Service de Santé des Armées, Bp 87, 38702 La Tronche France.

EVALUATION OF CYTOGENETIC EFFECTS OF VERY SHORT
LASER PULSED RADIATIONS

The aim of this study is to evaluate the capacity of a laser, delivering very short pulses in the near infrared spectrum with a high pulse ratio frequency, to induce genetic modification on biological tissues. Chromatid exchanges and chromosomal aberrations studies are used to test this potential effect on human lymphocytes. The laser irradiation induces a significant increase of acentric fragments but the absence of dicentric suggests that a repetitive very short pulses irradiation has a relatively low capacity to induce genetic abnormalities.

INTRODUCTION

Cette étude s'inscrit dans un cadre plus général qui a pour but d'évaluer l'influence éventuelle d'un rayonnement laser à impulsions très brèves sur les tissus biologiques. Des études antérieures ont mis en évidence différentes lésions du matériel génétique produites par l'exposition au faisceau laser. Les anomalies les plus fréquemment rapportées sont d'origine cytogénétique ou affectent le cycle de division cellulaire [1, 2, 3, 4]. Elles sont les conséquences d'une action photochimique ou thermique provoquée par des lasers continus ou impulsions (10⁻⁶ à 10⁻² s). Aucune étude n'a été menée pour étudier au niveau cellulaire les effets des lasers à impulsions très brèves (< 10⁻⁷ s) qui entraînent des effets multiphotoniques et non linéaires. Cette étude a pour but d'évaluer la capacité d'un laser, délivrant des impulsions très courtes à cadence élevée dans le proche infrarouge, à produire d'éventuelles modifications génétiques. Nous avons testé cet effet potentiel sur des lymphocytes humains en observant les échanges de chromatides et les aberrations chromosomiques éventuellement induites.

MOYENS ET METHODES

Les lymphocytes obtenus par prélèvement sont centrifugés et irradiés sous forme de culot dans un tube plastique stérile. L'irradiation est effectuée avec un laser Nd:YAG à la longueur d'onde de 1064 nm. Les impulsions, d'une durée de 50 ns, sont délivrées à la fréquence de 1 kHz. La variation d'énergie est obtenue en faisant varier la durée du train d'impulsions. Dès l'irradiation terminée, les cellules sont mises en culture pendant 48 h et 72 h avant que soient effectuées les recherches des aberrations chromosomiques et des échanges de chromatides sœurs (ECS). A chaque irradiation une culture témoin était effectuée dans les mêmes conditions.

RESULTATS

Le nombre des anomalies observées sur les chromatides après une irradiation laser est élevé, tant sur les cellules irradiées que chez les témoins. Le taux d'ECS par cellule observé chez les témoins ($7 \pm 0,4$) ne diffère que très peu des taux $6,63 \pm 0,4$ et $7,86 \pm 0,5$ relevés parmi les cellules irradiées avec des énergies respectives de 1220 mJ (270 impulsions) et 1612 mJ (410 impulsions). Par contre, le taux d'anomalie portant sur les seuls chromosomes est significativement différent. Les résultats présentés à la figure 1 ont été obtenus pour des énergies de 323, 744, 1154, 1596 et 1865 mJ. Ces valeurs sont les énergies moyennes des expérimentations répétées et réalisées avec des expositions comportant respectivement 100, 200, 270, 410 et 490 impulsions. La plupart des anomalies observées parmi les cellules irradiées sont des fragments acentriques. Aucun chromosome dicentrique n'a été observé.

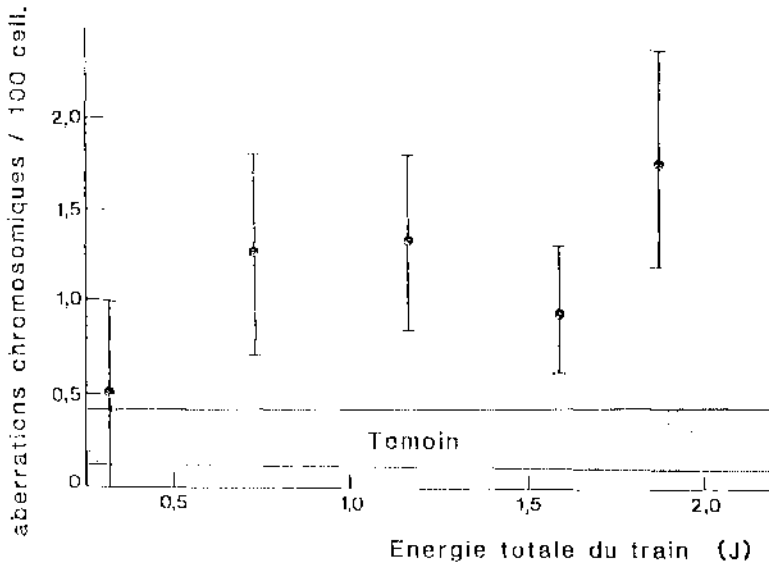

Figure 1: Taux d'anomalie chromosomiques (fragments) observé en fonction de l'énergie totale, exprimée en Joule, délivrée par le train d'impulsions laser.

DISCUSSION ET CONCLUSION

L'irradiation par un faisceau laser, fonctionnant de manière impulsionnel, peut induire des effets cytogénétiques sur des lymphocytes du sang circulant. Ces effets sont essentiellement caractérisés par une augmentation des fragments chromosomiques. Il est probable que la présence de dicentriques, parmi les anomalies chromosomiques observées par d'autres auteurs, soit la conséquence du mode d'irradiation utilisé. En effet, après une irradiation continue de plusieurs dizaines de minutes, les dicentriques apparaissent dès la première génération de culture cellulaire mais, après une exposition de 1 ms, il est nécessaire pour les observer d'augmenter l'exposition énergétique et d'observer les cultures cellulaires jusqu'à la 3ème génération [1,4].

L'absence de dicentriques dans nos cultures cellulaires suggère que le mode d'irradiation par impulsions brèves présente, par rapport aux autres modes d'irradiation, une capacité à induire des anomalies génétiques relativement faible [5, 6]. Pour confirmer cette hypothèse, il conviendrait d'étudier l'expression oncogène après exposition au même faisceau. Ceci permettrait d'apprécier, à un niveau moléculaire, si les altérations susceptibles d'être induites par un tel rayonnement peuvent être à l'origine d'une transformation cellulaire et d'un mécanisme de cancérogénèse.

BIBLIOGRAPHIE

1. D.E. Rounds, E.C. Chamberlain and T. Okigaki, 1964, Laser radiation of tissue cultures. *Ann. N.Y. Acad. Sci.*, 122, 713-727.
2. J.S. Paul, R.C. Zugola, P.A. Fong and M.J. Kop, 1970, Laser-induced changes in DNA synthesis and embryonic developments in sea urchins. *Exp. Cell Res.*, 60, 166-174.
3. M.W. Berns and W.K. Cheng, 1971, Chromosome lesions produced with argon laser microbeam without dye sensitization. *Science*, 171, 903-905.
4. M. Nakajima, M. Fukuda, T. Kavoki and K. Tsumi, 1983, Cytogenetic effects of argon laser irradiation on chinese hamster cells. *Radiation Res.*, 93, 598-600.
5. L. Court and D. Courant, 1990, Biological effect of coherent and non coherent IR radiation. in *Optical sources, lasers and synchrotron radiation - Biological effects and hazard potential.* (A. Rindi, M. Grandolfo and D.H. Sliney), Plenum Press, New-York, 1990, sous presse.
6. L. Court, D. Courant and D. Dermont, 1990, Medical lasers and biological criteria and limits of their therapeutic effect. In: *Optical sources, lasers and synchrotron radiation - Biological effects and hazard potential.* (A. Rindi, M. Grandolfo and D.H. Sliney), Plenum Press, New-York, 1990, sous presse.

A STUDY ON THE INFLUENCE OF 50-Hz MAGNETIC FIELDS
ON THE CYTOTOXIC ACTIVITY OF HUMAN NATURAL KILLER CELLS

C. Ramoni⁽¹⁾, M.L. Dupuis⁽¹⁾, P. Vecchia⁽²⁾, M. Grandolfo⁽²⁾

Department of Immunology (1) and Department of Physics (2)
Istituto Superiore di Sanità, Rome, Italy.

ABSTRACT

The effect of exposure to 50-Hz sinusoidal magnetic fields on the cytotoxic activity of fresh human natural killer cells has been investigated. Either effector or target cells were exposed to a homogeneous magnetic flux density ranging from 0.1 to 10 mT. The experimental results do not show evidence of an effect for any of the exposure conditions, suggesting that magnetic fields do not inhibit significantly the cytotoxic activity of peripheral blood lymphocytes.

INTRODUCTION

In the last years, a continuously increasing attention has been devoted, inside both the scientific community and the public opinion, to the biological effects of extremely low frequency (ELF) magnetic fields. The results of some epidemiological studies⁽¹⁾ have in fact indicated a possible association between long-term exposure to the magnetic fields generated by large electrical plants, in particular power lines, and the development of some kind of tumors.

In order to hypothesize a causal link between magnetic fields and cancer, a plausible biological mechanism of interaction is to be identified, which should account for the promoting action of the magnetic field.

Taking into account the present hypotheses on the potential carcinogenicity of power frequency magnetic fields, the study of possible effects on the *in vitro* immune response is deemed of uppermost interest.

In the light of the important role of the immunosurveillance system, we investigated the effect of power-frequency magnetic fields on the cytotoxic activity exerted by a small population of peripheral blood mononuclear cells, named natural killer (NK) cells. These cells have recently become the subject of extensive laboratory investigation.

NK cells are operationally defined as cells capable of mediating spontaneous *in vitro* cytotoxicity against a variety of target cell populations without apparent prior sensitization. They are involved in a large number of different immunological functions including cytotoxicity against tumor cells and virally transformed cells, resistance to some microbial, fungal, and parasitic agents, regulation of some lymphokine secretion, regulation of hemopoiesis, and natural resistance to allogeneic grafts.

In this study, the effect of 50-Hz sinusoidal magnetic field is investigated on the allogeneic cytotoxicity reaction conducted *in*

vitro by peripheral blood lymphocytes (PBL) effector cells acting on K562 target cells (specially sensitive to NK lysis).

EXPERIMENTAL

A sinusoidal 50-Hz magnetic field was generated inside coils of 18 cm diameter and 50 cm height, with a winding of 6 turns/cm. That allowed a quite homogeneous field in all the central region of the coil, where the samples were located. The current intensity was controlled by a Variac potentiometer, so that the magnetic flux density could be varied up to about 10 mT. The actual value of the magnetic field density was continuously monitored by the narrow Hall-probe of a gaussmeter, which was inserted in the coil at the sample location.

Although the magnetic flux density could be set within a precision of 2%, variations of the order of 5% generally occurred throughout the exposure period, due to instability in the electric network.

Through a Variac potentiometer, the magnetic flux density was varied between 0.1 and 10 mT, i.e. of the same order of magnitude of exposure limits for workers and population recommended by the recent IRPA/INIRC guidelines⁽²⁾.

PBL from fresh human blood, freed of adherent cells, were divided into two samples at 10^6 /ml concentration and suspended in culture medium. One sample was exposed to the magnetic field, while the other was sham-exposed.

All the exposure system was included in an incubator at 37 °C and 5% CO₂. Exposure lasted the whole incubation time (70 h).

Cytotoxicity was then assayed by mixing effector cells to ⁵¹Cr-labelled cells with effector-to-target (E/T) ratios ranging between 50:1 and 6.25:1. The reaction mixture was incubated for 3 h at 37 °C. All groups were tested in triplicate.

The percent ⁵¹Cr release R_s was calculated as:

$$R_s = 100 (R_t - R_s) / (R_m - R_s)$$

where R_t , R_s , and R_m are the test, spontaneous, and maximum release, respectively.

RESULTS AND DISCUSSION

Results of 3-hour ⁵¹Cr-release cytotoxicity tests are reported, for three different magnetic flux densities, in Figs. 1-3. Data relative to other exposure levels exhibit the same behaviour.

It has been suggested^(3,4) that the cellular plasma membrane may be a major target for ELF magnetic fields. Possible effects on cell-mediated lysis might therefore be related to action on either the effector or target cell membrane.

The experimental data do not show any significant change of the cytotoxic activity by NK cells after exposure of either effector cells (Fig. 1), or target cells (Fig. 2), or both (Fig. 3).

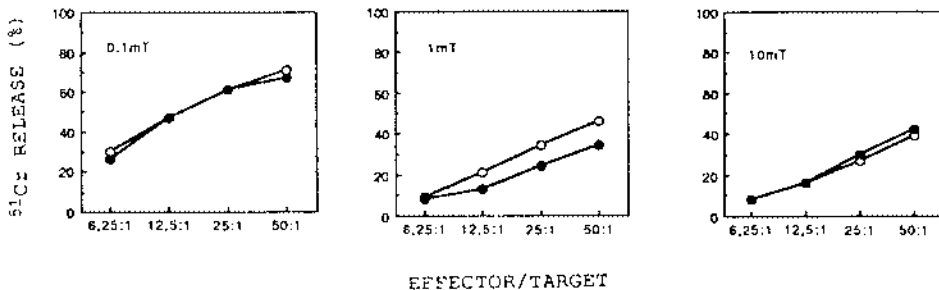

Fig. 1. Comparison of cytotoxic activity of exposed (●) and non-exposed (○) NK effector cells on K562 target cells.

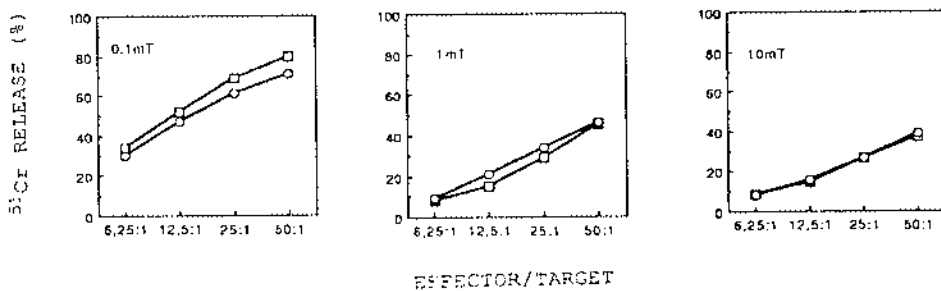

Fig. 2. Comparison of cytotoxic activity of NK effector cells on exposed (□) and non-exposed (○) K562 target cells.

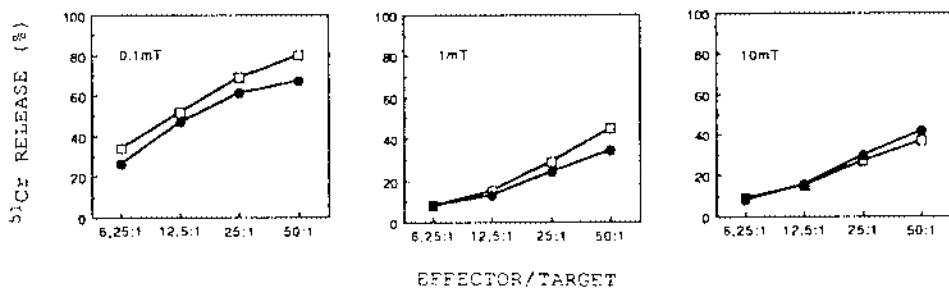

Fig. 3. Comparison of cytotoxic activity of exposed NK effector cells on exposed K562 target cells (●) and non-exposed NK effector cells on non-exposed and non-exposed K562 target cells (□).

Repeated experiments on blood from different donors show the same behaviour, independently on the individual variability.

Our findings therefore suggest that the exposure to 50-Hz sinusoidal magnetic fields do not have relevant effect on the behaviour of NK cells. In contrast, Lyle et al.⁽⁵⁾ reported a significant inhibition of allogeneic cytotoxicity by murine T-lymphocyte line CTLL-1 exposed to 60-Hz electric field, suggesting a possible effect on activated cells.

To test this hypothesis, research is in progress on activated lymphocytes. Preliminary results seem to indicate a significant inhibition of the cytotoxic activity when activated effector cells are exposed to 50-Hz sinusoidal magnetic fields.

ACKNOWLEDGEMENTS

The Authors are very indebted to Mr. V. Angelini and Mr. E. Chiotti for their skilled technical assistance, and to Mr. M. Sabatini for his invaluable help in data management.

This study has been supported by the CNR-ENEL Project - Interactions of energy systems with human health and environment - Rome, Italy

REFERENCES

1. Coleman M. and Beral V, 1988. A review of epidemiological studies on the health effects of living near or working with electricity generation and transmission equipment. *Int.J.Epidemiol.* 17, 1-13.
2. IRPA/INIRC, 1990. Interim guidelines on limits of exposure to 50/60 Hz electric and magnetic fields. *Health Phys.* 58, 113-122.
3. Phillips, J.L., Winters, W.D. and Rutledge, L., 1986. *In vitro* exposure to electromagnetic fields: changes in tumor cell properties. *Int. J. Radiat. Biol.* 49, 463-469.
4. Grandolfo, M., Santini, M.T., Vecchia, P., Borincontro, A., Cametti, C. and Indovina, P.L., 1991. Non Linear Dependence of the Dielectric Properties of Chick Embryo Myoblast Membranes Exposed to a 50-Hz Magnetic Field. *Int. J. Rad. Biol.* 60, 877-890.
5. Lyle, D.B., Ayotte, R.D., Sheppard A.R. and Adey, W.R., 1988. Suppression of T-Lymphocyte Cytotoxicity Following Exposure to 60-Hz Sinusoidal Electric Fields. *Bioelectromagnetics* 9, 303-313.

ELECTROPHYSIOLOGICAL CHANGES IN RATS AFTER MODULATED MICROWAVE IRRADIATION

Szabo L.D., Thuroczy G., Kubinyi G., Bakos J.
Natl. "Frederic Joliot-Curie" Res. Inst. for Radiobiology and
Radiohygiene, Budapest H-1775 POB.101., Hungary

ABSTRACT

The effects of modulated microwave irradiation on the electrophysiological changes in rats were studied. The response of the central nervous system (CNS) was observed simultaneously to the cardiovascular system by using quantitative polygraphic measuring system.

In acute experiments on rat the electroencephalogram (EEG), rheoencephalogram (REG) as an index of cerebral blood flow (CBF), brain tissue DC impedance and temperature, ECG were recorded in parallel before, during and after exposure of the brain localized amplitude (AM) modulated (16 Hz) and continuous wave (CW) microwave exposure. The average specific absorption rates (SAR) in the brain were 8.4 mW/g, 16.8 mW/g and 42 mW/g (CW) respectively.

At thermal level CW exposure the delta band of EEG increased. In case of low intensities modulated exposure the beta band of EEG spectrum increased. No changes were observed during athermal CW irradiation on the EEG. Moderate modulation depended changes were measured in cerebral metabolism, cerebral blood flow and cardiorespiratoric system during microwave irradiation.

INTRODUCTION

The psychophysiological background of complains of workers occupationally dealing with microwave and radiofrequency (RF) equipments which are related to the effects of weak electromagnetic field on the central nervous system (CNS) have not been clarified nor the question: which physiological modalities are in correlations with the intensity, carrier frequency or modulation of microwave and RF radiation. The compensation factors of regulation which are involved in response to the radiation may have an important role in the mechanisms.

We suppose that effects on the brain tissue and cell membrane which are exposed of microwave and RF radiation mostly depend on the frequency and type of modulation, specially the amplitude modulation (AM) below 100 Hz [1,3,9]. Adey et al. showed a special "window" effect by using Ca^{++} -efflux measuring methods in the brain cortex of cat [1,2]. They have found frequency and intensity bands in which the Ca^{++} -efflux were changed in the presence of weak electromagnetic fields below 100 Hz (ELF) and ELF modulated RF fields.

The increase in the cerebral blood flow after microwave exposure is known to occur and these changes depend on the duration of exposure [4,5]. Otherwise it was found that the slow waves of EEG raised after RF or microwave exposure [9].

Our experiments are based on the following questions:(i) An athermal weak modulated or continuous wave (CW) electromagnetic microwave and RF field cause measurable effects

on the systemic and/or localized regulation mechanisms of the central nervous system ? (ii) Does the signal processing evaluation of measured biopotentials (ie. quantitative polygraphy) give more information on the basis of the electromagnetic fields interaction with living systems ?

METHODS

MICROWAVE EXPOSURE AND DOSIMETRY

The irradiation were performed in a waveguide system setup TE-cell. A standard WR 40 waveguide was extended up to 100X60 mm and connected a horn to the waveguide. The incident, reflected and transmitted power were measured by directional couplers and power meters in the 3.4-4.4 GHz frequency [10]. The spatial pattern of SAR distribution in the brain cortex was measured with a thermocouple (0.18 mm, 40 mV/°C). The animal head was placed toward the generator.

The average SAR in the cortex was 8.4 mW/g, 16.8 mW/g and 42 mW/g using 300 mW, 600 mW and 1500 mW incident power respectively. The microwave frequency was 4 GHz and the modulation frequency was 16 Hz sinus (mod.depth 70 %). The duration of exposure was 30 min.

ELECTROPHYSIOLOGICAL PROCEDURE AND RECORDING

On F1-hybrid male anesthezied rats (180-200 g, Nembutal 60 mg/kg ip.) standard electrophysiological procedure were performed. The NICROTHAL stainless steel metal electrodes were placed symetrically to the saggital suture. The irradiation and registration were performed 2 weeks after the surgery (n=40).

In acute experiments (5 in each group, Nembutal 40 mg/kg ip.) the following electrophysiological modalities were registered simultaneously: EEG (70 Hz/0.3 s), DC brain tissue impedance (2.5 kohm/V), rheoencephalogram-REG (Time const.: 3s), brain tissue and rectal temperature, ECG (150 Hz/0.3 s).

SIGNAL AND DATA PROCESSING

The signal and data processing were based on the microcomputer IBM-AT with the following hardware and software: analogue memory, memory scope, recorders, A/D card (12 bit) and microcomputer aided data acquisition and processing system (A/D conversion, average, SD computation, FFT with 0.4 Hz accuracy, auto- and cross correlation, cursor operations). The obtained outputs of the data processing are the follows:

- Heart Rate (HR) beat/min.
- Pulse Delay (PD): REG ampl. max - ECG R-peak interval time.
- Amplitude of rheoencephalogram (REG ampl.)
- EEG frequency bands derived from the power spectrum by FFT analysis with 0.4 Hz accuracy. The processed interval of EEG signal were 10x2.5 sec and the power spectrum of epochs were averaged parallely. The separated frequency bands: delta (0.4 Hz-4 Hz), theta (4.4-8 Hz), alpha (8.4-14 Hz), beta (14.4-30 Hz).

Respiration frequency: beat/min

Before (baseline), during (3., 20., 30. min) and after (1., 20. min) 25 sec. of registration were processed. The results are expressed and illustrated in the figures in percent of the baseline values.

RESULTS

The signal processing and statistical evaluation of the electrophysiological modalities gave the following results:

- The CW irradiation at 42 mW/g SAR in the brain causes a significant increase in the delta band (0.4-4 Hz) and slight increase in the theta band (4.4-8 Hz) of EEG (Fig 1.). The rheoencephalogram increased simultaneously but there was no significant changes in the heart rate.
- The 4 GHz CW athermal level irradiation with 8.4 mW/g and 16.8 mW/g SAR in the brain did not cause changes in any frequency bands of the EEG, but 16 Hz modulated irradiation causes a significant alteration in the beta band of EEG (Fig.2.).
- The REG amplitude increased during CW non-thermal irradiation but the REG amplitude change during non-thermal modulated irradiation was not significant.
- The DC brain tissue impedance decreased depending on the type of modulation.
- In the slight decreased tendency of the pulse delay (PD) there were no sign.differences between the CW and modulated groups.
- The ECG profile showed slight transient bradycardia during exposure to both of CW and 16 Hz modulated waves as well.
- During the alterations of 8.4 mW/g and 16.8 mW/g no temperature increase was measured in the brain tissue and the rectum ($DT < 0.1^{\circ}C$).

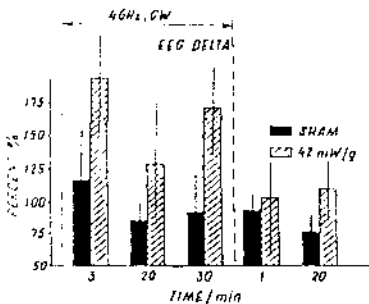

Fig.1. EEG slow waves (delta band:0.4-4 Hz) increase during (3, 20, 30 min) and after (1, 20 min) the 4 GHz, CW irradiation. Values (N=5) presented are in percent of baseline (before irradiation). The 42 mW/g SAR in the cortex of rat represents the averaged value.

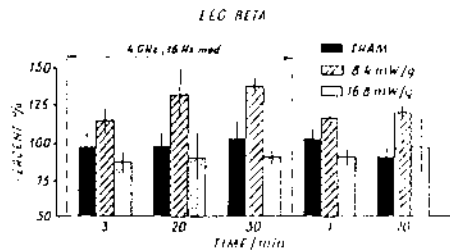

Fig.2. EEG beta band (14.4-30 Hz) during (3, 20, 30 min) and after (1, 20 min) the 4 GHz 16 Hz modulated (b) irradiation. Values (N=5) presented are in percent of baseline (before the irradiation). The SAR represents the averaged value in the brain cortex of rat.

DISCUSSION

Slight changes in cerebral metabolism and blood flow were observed during microwave irradiation. These transient alterations did not exceed the range of normal physiological regulation, but had a various involvement of compensating factors with different speed.

In the changes of EEG spectra during modulated irradiation were significant, but did not show dependence on the values of SAR in the brain. These results can not be explained by the EEG only [6,8]. The effect on cerebral circulation was quite definite which is well in agreement with results in the literature [5]. The microwave field interactions has an effect not only on the electrical activity of the brain tissue and the cerebral blood flow but also on the blood vessels. Changes in the measured tissue impedance of the vascular pulsation of the brain tissue (REG) can be explained not only as an effect on the cerebral blood flow and the wall of vessels but also is an effect on the electrical conductivity of the tissue and the rheological quality of the blood [7].

Because of the close correlation in the circulation-metabolism-function system of the brain, the low level of irradiation (ie. 8.4 mW/g, 16.8 mW/g) did not cause considerable changes in the measured polygraphic modalities, namely below the physiological regulation in the brain system the compensation mechanisms can be detectable. However, beyond the athermal level irradiation (42 mW/g) the changes remained in the range of the physiological regulation, but the effects on metabolisms and circulation were more detectable.

R E F E R E N C E S :

- [1] Adey, Wr.(1975):Evidence for Cooperative Mechanisms in the Susceptibility of Cerebral Tissue to Environmental and Intrinsic Electric Fields,in:Schmitt F.O.(ed):Functional Linkage in Biomolecular Systems, Raven Press NY, pp 326-342.
- [2] Adey W.R.(1990): Electromagnetic Fields and the Essence of Living systems, in Andersen J.B.(ed): Modern Radio Science 1990, pp:1-36, Oxford Univ.Press.
- [3] Blackman,C.F., Benane S.G., House D.E., Joines W.T.(1985): Effects of ELF(1-120 Hz) and modulated (50 Hz) RF fields on the efflux of calcium ion from brain tissue in vivo, Bioelectromagnetics,6,1.
- [4] Joines W.T.(1976): Reception of Microwaves by the Brain, Med.Res.Eng. Vol.12. No.3..
- [5] Oscar K.J.et al(1981): Local cerebral blood flow after microwave exposure, Brain.Res.,204.,pp.220-225.
- [6] Predmerszky T., Ballay L., B010ni E., Szab= L.D., V'mos L.(1982)> Investigation on microwave radiation exposure, Acta Physica Acad.Sci.Hungary, Vol.52.pp.479/486..
- [7] Schwan H.P.(1987): Biological Effects of Non-ionizing Radiations: Cellular Properties and Interactions, The L.S.Taylor Lecture Series No.10.by NCRP, pp:9-42.
- [8] Szab= L.D.,Thur=czy G. et al (1986): Biochemical, Embriological and Electrophysiological Effects of Microwaves,in: URSI Symp. on EM Theory,Akademiai Kiad.pp.181-184.
- [9] Takashima S.et al (1978): Effects of Modulated RF Energy on the EEG of Mammalian Brains,in:Stuchly S.S.(ed): Electromagnetic Fields in Biological Systems,Ottawa.
- [10] Thur=czy G. et al (1986): An Irradiation and Measuring System for the Study of Biological Effects of Microwaves, in URSI Int.Symp.on EM Theory,Akademiai Kiado,pp 241-244.

IN VITRO STUDY ON THE GENOTOXICITY OF 2450 MHz MICROWAVE IRRADIATION IN HUMAN PERIPHERAL BLOOD LYMPHOCYTES

L. Verschaeve¹, A. Maes¹, A. Arroyo¹, C. De Wagter² and L. Martens³

¹ Dept. Biology, Vlaamse Instelling voor Technologisch Onderzoek (V.I.T.O.), B-2400 Mol, ² Dept. Radiotherapy and Nuclear Medicine, Universitair Ziekenhuis, B-9000 Gent and ³ Lab. of Electromagnetism and Acoustics, Universiteit Gent, B-9000 Gent, Belgium.

ABSTRACT

A cytogenetic analysis was performed on human peripheral blood lymphocytes exposed to 2450 MHz microwaves during 30 and 120 minutes respectively. The exposure system developed allows a temperature control by means of a temperature probe put in the blood sample which gives feedback to a microcomputer. In the present study irradiation was performed at a constant temperature of 37°C for the whole exposure period. We found a marked increase in the frequency of chromosomal aberrations as well as micronuclei. On the other hand microwave irradiation did not influence the cell kinetics nor the sister chromatid exchange frequency.

INTRODUCTION

Microwaves have, like other non ionizing radiations (NIR), a lot of industrial, medical and other applications. They are for example widely used for communication purposes (satellite communication, radar, radio/TV,...), therapy, cooking and a lot domestic or industrial heating procedures. As a consequence everybody is exposed to microwaves. Harmful (and also beneficial) effects on the living organism are sometimes reported but are often questionable^{1,2,3,4}. Although there is much evidence in favor of the non-genotoxicity of microwaves, it

was reported in some papers that microwaves may be mutagenic^{5,6,7}. In order to verify this assumption we performed an in vitro cytogenetic analysis in human peripheral blood lymphocytes exposed to 2450 MHz microwaves. This paper describes some of our preliminar results.

MATERIAL AND METHODS

A freshly obtained blood sample from a 38 year old male donor was divided into three test tubes and resp. irradiated with 2450 MHz microwaves for 30 or 120 minutes, or kept at 37°C in a warm water bath. The exposure system used was developed to provide two modes of operations: temperature control and electric field control^{8,9}. In this study we used the temperature controlled mode in order to work at the constant temperature of 37°C. Therefore a temperature microprobe was put into the blood sample. Connected with a microcomputer it results in automatic adjustment of the microwave output allowing to rapidly obtain and closely maintain the prescribed temperature (37°C) within 0.05°C for the time of irradiation.

After irradiation cells were cultivated during 48 or 72 hrs according to standard methodologies for analysis of chromosome aberrations¹⁰, micronuclei¹¹, cell kinetics and sister chromatid exchanges (SCE)¹⁰.

RESULTS

Results of this preliminar cytogenetic study are summarized in tables 1-3. A marked increase in the frequency of chromosomal aberrations is observed, especially after a 120 minutes irradiation period. These aberrations comprise dicentric chromosomes and acentric fragments that are usually found after ionizing radiation exposure (table 1). The frequency of micronuclei increased equally for both irradiation periods (table 2). Differential staining of BrdU incorporated chromatids allows analysis of the cell kinetics and SCE. Table 3 shows that the cell kinetics nor the SCE frequency were significantly influenced by the microwave irradiation.

CHROMOSOME ABERRATIONS (per 200 metaphases)								
	gaps	breaks	acentric fragments	dicentric +/- ac. fragm.	other aberr.	number of cells		
						1	with 2	3
						aberrations		
CONTROLS	2	2	1	0	0	3	1	0
30 min. irradi.	4	1	3(2)	1 ⁺	0	9	0	0
120 min. irradi.	7(1)	9	13(3)	1 ⁺	3(4)	19	6	2

Table 1: Chromosome aberrations in 2450 MHz microwave irradiated human lymphocytes at a constant temperature of 37°C. (1): including two isogaps, (2): here all acentric fragments are single chromatid fragments (but apparently no chromatid break present), (3): including one acentric ring, (4) includes two translocations and one centromere splicing (no particular staining was used to detect translocations; those mentioned are only the very obvious ones due to a striking chromosome morphology).

MICRONUCLEI (per 1000 binucleated cells)			
	Number of cells		Total number of micronuclei
	with 1 micronucleus	with >1 micronucleus	
CONTROL	3	1(1)	5
30 minutes irradi.	23	0	23
120 minutes irradi.	11	2(2)	17

Table 2: Number of micronuclei in cytochalasin B blocked human lymphocytes irradiated with 2450 MHz microwaves at a constant temperature of 37°C. (1) and (2) : resp. cells with 2 and 3 micronuclei.

	CELL KINETICS (200 metaphases)						SCE FREQUENCY in 50 M2 figures (mean per cell)	
	% of	48 hr cultures			72 hr cultures			
		M1	M2	M3	M1	M2	M3	
CONTROL		91	9	0	14	41	45	5.88
30 min. irradi.		93	7	0	19	47	34	5.56
120 min. irradi.		88	12	0	20	40	40	7.16

Table 3: Frequency of 1st, 2nd or 3rd metaphases and SCE frequency in human lymphocytes irradiated at a constant temperature of 37°C with 2450 MHz microwaves and cultivated during 48 and 72 hours.

DISCUSSION

In this study irradiation was performed at a constant temperature of 37°C which could be obtained by adaptation of the microwave power output. The power intensity was thus variable but low enough as to maintain irradiation at non-thermal conditions. In this respect it is rather surprising to observe chromosomal aberrations. Indeed, 2450 MHz microwaves have a wavelength of 12.2 cm in free space and a photon energy which is much less than 12 eV. This means that even the weakest chemical bond in DNA is not likely to be broken by the microwaves. However, our results are in agreement with others presenting data for other frequencies and power densities^{5,6,7}.

The present study is only a preliminary stage in a series of experiments aimed at better understanding the microwave effects on biological systems, especially on the genetic material of mammalian cells.

REFERENCES

1. Cleary, S.F., 1983, Bioeffects of microwave and radiofrequency radiation, In: F.K. Storm (ed.), *Hyperthermia in cancer therapy*, G.K. Hall Medical Publishers, Boston, Massachusetts, pp. 545-561.
2. WHO, 1983, Radiofrequency and microwaves, *Environmental Health Criteria* 16, 134 pg.
3. Foster, K.R. and Guy, A.W., The microwave problem, *Sci. Am.*, 255, 32-39.
4. Wilkening, G.M. and Sutton, C.H., 1990, Health effects of nonionizing radiation, *Med. Clinics North America*, 74, 489-507.
5. Léonard, A., Berteaud, A.J. and Bruyère, A., 1983, An evaluation of the mutagenic, carcinogenic and teratogenic potential of microwaves, *Mutation Res.*, 123, 31-46.
6. Garaj-Vrhovac, V., Horvat, D. and Koren, Z., 1990, The effect of microwave radiation on the cell genome, *Mutation Res.*, 243, 87-93.
7. Garaj-Vrhovac, V., Horvat, D. and Koren, Z., 1991, The relationship between colony-forming ability, chromosome aberrations and incidence of micronuclei in V79 chinese hamster cells exposed to microwave radiation, *Mutation Res.*, 263, 143-149.
8. De Wagter, C., Gheeraert, P. and Van Loock, W., 1985, Narrowband microwave generator using a commercial magnetron, *Proc. 20th Annual Microwave Power Symposium*, Chicago, 124-127.
9. De Wagter, C., Martens, L., Verschaeve, L. and Maes, A., 1992, Computer controlled microwave exposure system: results of an in vitro cytogenetic study on human peripheral blood lymphocytes, *Proc. 1st World Congress for Electricity and Magnetism in Biology and Medicine*, in press.
10. IAEA, 1986, Biological dosimetry: chromosome aberration analysis for dose assessment, International Atomic Energy Agency, Vienna, pp. 69.
11. Van Hummelen, P. and Kirsch-Volders, M., 1990, An improved method for the 'in vitro' micronucleus test using human lymphocytes, *Mutagenesis*, 5, 203-204.

RADIATION PROTECTION QUALIFICATIONS

J. R. A. Lakey¹ and M. M. Wasson²

¹John Lakey Associates, Meopham, Gravesend, UK

²Society for Radiological Protection

6 Church Road, Burnham-on-Crouch, Essex, UK

ABSTRACT

In 1979 the UK Society for Radiological Protection adopted a scheme of Certification of Competence in Applied Radiation Protection. The scheme was linked to the concept of "Qualified Expert" defined in the 1976 Euratom Directive and the translation of the Directive into UK Legislation created the Radiation Protection Adviser (RPA), a statutory appointment for an Health Physicist. In 1983 the Hospital Physicists Association introduced a similar scheme and in 1991 the two schemes adopted a joint Certificate of Competence to Practice and Advise in Radiation Protection, and there are now 300 persons on these registers.

INTRODUCTION

The United Kingdom has never specified statutory qualifications for the professionals who plan, direct or conduct programmes for the evaluation and control of radiation hazards. The lessons learned from the 1957 Windscale Accident indicated a need for suitable categories of radiation protection staff with specified training. The European Directive of June 1976 was translated into UK legislation through the Ionising Radiations Regulations 1985 and three categories of Qualified Expert were recognised, the Radiation Protection Adviser, the Radiation Protection Supervisor and the Qualified Person. Only the first of these can be linked to the international concept of a Health Physicist and the response of the profession to the specification of qualifications for appointment to this category was the inspiration for the Certificate of Competence awarded by the professional societies.

POST WINDSCALE CATEGORIES

In 1960 following the Windscale Accident the Veale Committee (1) made recommendations for suitable training for three categories of staff engaged in radiological protection duties:-

- Category A. Graduates with the capacity to assume higher management duties or to play a leading part in research and development.
- Category B. Graduates or non-graduates with day-to-day management responsibility.
- Category C. Technical and other supporting staff.

This scheme dominated the UK education and training programme (2) and a number of masters courses, post-graduate diploma courses and specialist short courses were evolved to satisfy the needs of Category A and B. However there was no formal recognition of these persons as qualified for any specific appointment. The professional societies demanded a first degree as entry qualification and accepted an MSc as equivalent to one year of experience.

In June 1976 the Euratom Directive introduced the European concept of the Qualified Expert covering a very wide range of duties and standards. At that time it seemed unlikely that a scheme could be produced which would encompass both medical and industrial uses of ionising radiation and in any case no one person could be expected to carry the full range of responsibilities attached to the duties of the Qualified Expert.

The Directive was ratified in the UK when the Ionising Radiations Regulations 1985 were introduced. These gave recognition to three categories of Qualified Expert:-

Radiation Protection Adviser.

A person suitable qualified and experienced to advise "as to the observance of these regulations and as to other health and safety matters in connection with ionising radiation".

Radiation Protection Supervisor.

An employee responsible for supervising the work with ionising radiation "to the extent necessary to enable the work to be carried on in accordance with these Regulations".

Qualified Person.

A person suitable qualified and experienced to supervise the testing of monitoring equipment prior to, and in, service as required by the Regulations.

The RPA is equivalent to the Health Physicists employed by large organisations who would have been identified by the Veale Committee as Category B. They have a strong similarities to the Certified Health Physicist (CHP) of the American Board of Health Physics.

In 1976 the Society for Radiological Protection set up a working party to examine the situation and to make recommendations about setting up a register of people who would be "suitably qualified and experienced" from which employers could appoint RPAs with confidence.

The proposals were adopted and the Certification Scheme was inaugurated in 1976 when a small number of senior members were selected by the executive council for the first awards. In 1983 the Hospital Physicists Association, later to become the Institute of Physical Sciences in Medicine, set up a similar scheme for those radiological protection specialists working in Medicine and Dentistry. From the start both Societies recognised the need for comparable standards and maintained close links; each society was represented on the others assessment panel. In 1991 both schemes adopted a single procedure and awarded a joint "Certificate of Competence to Practice and Advise in Radiation Protection".

CERTIFICATION STANDARDS

The standard required for certification is training, experience and proven ability in one or more fields of radiation protection. An Assessment Panel of senior members with wide experience is appointed by each Society. Successful candidates have to adhere to a Code of Conduct and the validity of both Certificate is 5 years after which the Certificated person must demonstrate continued active involvement in radiation protection. There is no specified need for Continuing Education but evidence of this is taken as an indication of active participation in the field.

The formal requirements are:

1. A degree in Physical Science or exceptionally other qualifications with extensive relevant experience.

2. Three years full time experience in a post directly concerned with operational radiation protection, preferable supervised by a Certificated person or by a person of equivalent status. An approved course may be accepted in lieu of experience up to one year.

3. Professional knowledge of the fundamental principles and operational methods of radiation protection. The candidate must be capable of interpreting and applying radiation protection data and of supervising or carrying out practical measurements and control procedures for work involving significant exposure to ionising radiation.

4. The candidate must be capable of advising management on the implementation of relevant legislation. The candidate must be able to carry overall responsibility for radiation protection of operations in which there is a possibility in the normal course of events that at least one person may receive a dose in excess of 3/10 of the relevant limit.

REGISTRATIONS IN 1991.

The two registers have a total of 300 members. The distribution of field of work of SRP members is the following:

SECTOR	Number
Research including Atomic Energy Authority	20
Fuel fabrication and reprocessing (BNFL)	12
Defence including Royal Dockyards	37
Nuclear power	41
Central Government and NRPB	20
Medical	40
TOTAL.	170

Most of these Certificated Persons work in large organisation where the rôle of RPA is conducted as a corporate body. In the medical field it is estimated that about half of the Certificated persons are appointed as RPAs. Only half of the RPAs appointed in this field are Certificated.

CONCLUSION.

These schemes have been successful but the numbers of people involved is too small to sustain dedicated courses. The UK still has four courses at the MSc level which could lead to this Certification. The Society for Radiological Protection has now introduced the grade of Fellow and the profession seems to be advancing in status towards that of UK engineering professionals but lacks the international equivalence of qualifications. Engineers can attain Chartered Engineer status which is linked to the European profession through the Eur Ing scheme. A cautious move in this direction would be encouraged if an international evaluation of the safety related rôle of the radiation protection profession could be initiated to permit comparison with safety engineers in nuclear technology.

REFERENCES

- (1) "Training in Radiological Safety"
Sir Douglas Veale
HMSO, 1960
- (2) "Professional Standards in Radiological Protection"
J R A Lakey
J Soc Radiol. Prot. Vol 4, part 2, 1984.

THE NEW ICRP RECOMMENDATIONS: HOW WILL THEY BE TRANSLATED INTO PRACTICE?

O. Ilari, OECD/NEA; A. Gonzalez, IAEA; G. Hanson, WHO;
C. Borrás, PAHO; E. Boutrif FAO

The novel conceptual developments put forward by the new ICRP recommendations need to be converted into terms that can facilitate their transfer into regulatory texts and operational practices at the national level. The main problems that we may face in this conversion, through the revision of the Basic Safety Standards for Radiation Protection, are briefly discussed in this paper.

INTRODUCTION

During the last few years, radiation protection went through a period of significant developments and achievements. The major event in this period was the revision of the basic ICRP recommendations. Although the new recommendations represent an evolution more than a revolution with respect to the 1977 recommendations, they have introduced some important developments and significant elements of novelty. The new ICRP recommendations have been deliberately drafted in general and scientific terms so that sufficient scope for interpretation and application is left to their users, particularly the national authorities. There is, now, a need for a conversion of the ICRP guidance into terms which are sufficiently practical and straightforward to facilitate their transfer into regulatory and operational practices at the national level.

Traditionally, this is the task of the international intergovernmental organisations, in particular through the Basic Safety Standards for Radiation Protection (BSS), jointly issued by the IAEA/NEA/WHO and ILO, and the Euratom Radiation Protection Directives, issued by the CEC. In the past, this international applicative guidance was largely traced on the texts issued by the ICRP. This time, however, the higher degree of generality and flexibility of the ICRP recommendations is suggesting a different strategy in preparing the revision of the BSS. There will be, in fact, the need to make a serious effort of interpretation of the ICRP concepts and intentions, which will require expansions and clarifications from the ICRP text.

TRANSLATION OF THE ICRP RECOMMENDATIONS INTO PRACTICAL GUIDANCE

The first concerted effort to provide unified radiation protection standards to contribute to an harmonised worldwide application of the basic ICRP recommendations was made at the beginning of the eighties by the IAEA, the NEA, the WHO and the ILO. The result was the publication of the BSS issued in 1982 as IAEA Safety Series No. 9.

The work for the revision of the BSS was started at the beginning of 1991 with the constitution of a Joint International Secretariat among the four above-mentioned organisations, which were later joined by the Food and Agriculture Organization (FAO) and the Pan American Health Organization (PAHO), and the setting up of a Drafting Group in charge of the preparation of a draft text of the revised BSS to be submitted, in 1992, to international review and approval. It is interesting to note that this review will have a very transparent character in that not only

governmental, regulatory and professional groups, but also worker and employer organisations as well as other interest groups will be involved in the debate and give their contribution of ideas to the preparation of the new BSS.

Although a conclusive idea of the specific features of the new BSS can only be achieved when the international review process is completed, the Joint Secretariat has been able to establish a general strategy and agree on the main lines concerning this work. First of all, it was agreed that the BSS should be given the character of "Standards" that national authorities could use as a regulatory basis for the protection of workers and members of the public. This implies that the BSS should be written in a fully regulatory language; however, the Joint Secretariat quickly recognised that this may be difficult to achieve in practice, in view of the large variety of regulatory systems and associated legal languages used in Member countries. Therefore, it was agreed that, although the document should have a regulatory flavour and be, as far as possible, directly applicable in the preparation of national regulations, it should be kept at the technical level without attempting to be a "legal" text. Another important decision was that the document should be fully consistent with the new ICRP recommendations, unless there are in some points strong reasons which suggest variations in policy or interpretation.

SOME IMPORTANT ISSUES TO BE ADDRESSED IN THE NEW BSS

The guidance given by the previous ICRP recommendations and, subsequently, by the previous BSS was essentially focused on the control of "normal" exposures from what are now defined as "practices" involving artificial "sources". The merit of the new ICRP recommendations is to generalise its guidance to cover the whole network of possible exposure and control situations as it is summarised in the following scheme:

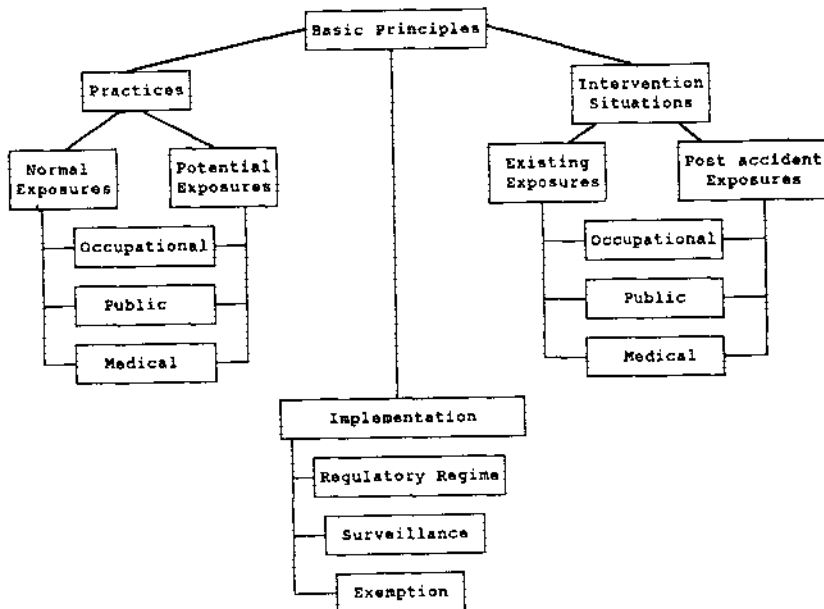

This scheme, in itself highly rational, creates problems of application due to the different degrees of controllability of the exposure which characterise the various situations. Some of the main issues to be addressed in the new BSS are highlighted in the following.

Individual Dose Limitation

Although optimisation of protection is confirmed as the main principle of a correct management of radiation exposures, the limitation of individual doses to workers continues to be the principal issue of concern to those who have the responsibility to implement radiation protection requirements in practice and it may be expected that a heated debate is raised on this issue during the preparation of the new BSS. In fact, several industrial and radiation protection operators have begun to express serious concerns on the feasibility of coping, at reasonable costs, with the new, reduced dose limits recommended by the ICRP. According to these critics, parts of the nuclear industry, and, perhaps, also other activities involving radiation might face major facility redesign and reorganisation of work practices, involving significant labour and cost increases, if this increase in the rigour of the international recommendations is followed by a similar stiffening of national regulatory requirements. Cases where these difficulties may arise include the maintenance of nuclear facilities, the operation of some underground uranium and other mines, some operations involving uranium and plutonium oxides, as well as some industrial applications and medical practices. These cases will have to be carefully examined to make sure that the requirements of the new BSS can be actually implemented.

Another issue which will have to be faced is the concept of flexibility proposed by the ICRP for the application of the dose limits. This concept, allowing a peak dose limit up to 50 mSv in one year against an average of 20 mSv per year over five years, is conceptually correct, but several regulators and operators have serious doubts on the concrete possibility to introduce it into laws and regulations, where only clear-cut rules and limits can fit with the required regulatory and legal language. One potential problem that could emerge with the introduction of a lower dose limit concerns those workers who have received so far doses in excess of 20 mSv per year. These workers and the trade unions might argue that they should now be guaranteed an annual dose limit lower than 20 mSv to compensate for what they could consider an unjustified past detriment. This is not a conceptual issue, nor is it of direct relevance to the text of the BSS, but its implications for the ensuing national regulations could not be overlooked.

All these considerations will have to be accommodated in the new BSS and the situation will be further complicated by the need to assign a place and a specific regulatory meaning to the new concept of source-related dose constraint introduced by the ICRP to limit the range of options considered in the procedure of optimisation of protection.

Exposure Situations not Fully Covered in Previous ICRP Recommendations

Historically, the ICRP recommendations mainly focused on the control of exposures that can be anticipated in advance and assumed to be delivered with virtual certainty and predictable magnitude. The new ICRP recommendations address two types of radiation-related activities not fully

covered by previous recommendations, namely the practices that may give rise to "potential exposures" and the "interventions". Not surprisingly, the available international guidance on radiation protection mainly concentrate on normal exposures. Apart from international standards for nuclear reactor safety, virtually no guidance exists for potential exposure situations and only general guidance is given internationally for intervention situations.

Clarification is, therefore, required of the role of the current principles of justification, optimisation and individual risk limitation in such situations. Any policy development should be tested against practical problems, such as specific requirements for the reliability of safety systems, the control of exposures due to radon in dwellings, and intervention levels for unanticipated situations. A particular and difficult problem to be dealt with in treating the question of potential exposures is that of solving the significant issues of interface with the philosophy and techniques used by the nuclear safety community in the safety analysis and prevention of nuclear accidents, which have been raised by these developments within the ICRP.

There are also problems in the area of interventions. For example, the new emphasis which is given nowadays to radon is not limited to the area of public exposure. The new ICRP recommendations suggest, in fact, to include exposure from natural sources as part of occupational exposure, but they do not provide unequivocal guidance on the choice of situations which should fall into this category. This will require interpretation and choice of options by those in charge of the preparation of the new BSS.

General Solutions: Standardization

A major shortcoming of the current radiation protection and safety policies is the lack of generic standardized objectives similar to those used in other safety disciplines. At a first sight, the rationale of ICRP requirements such as optimisation appears to be incompatible with generic solutions, because the requirements of optimisation seem to lead to case-by-case assessments. However, although there are specific problems for which only a case-by-case approach is feasible, it is worth questioning whether a more standardized approach could be possible for common, routine problems of protection and safety. Success in this endeavour would be very well received by designers and operators.

CONCLUSION

The issues highlighted in this paper are only some of the most important questions to be addressed in the implementation of the new ICRP recommendations. Several other problems of a more detailed nature can be raised by a reading of ICRP Publication 60, and a significant effort of interpretation and choice of options will have to be made in the transformation of the ICRP guidance into international recommendations liable to a concrete application. The new BSS will have to solve these questions in order to give an effective contribution to practical radiation protection in Member countries.

LE CEFRI ET LA CERTIFICATION EN RADIOPROTECTION
DES ENTREPRISES FRANCAISES

J.C Marillier - Cefri - Paris la Défense - France

THE CEFRI AND RADIOLOGICAL PROTECTION CERTIFICATION
OF FRENCH COMPANIES

In 1990, French nuclear operators and the nuclear industry set up a system for certifying the companies involved in industrial work with exposure to ionizing radiation and the concerned training organizations. Inspectors have been recruited and trained. The first certificates were issued during the past few months. The extension of this certifications to cover all work on nuclear sites is being envisaged.

INTRODUCTION

Le développement rapide du programme électro-nucléaire français a amené un grand nombre de travailleurs de l'industrie à travailler dans des zones où peuvent exister des rayonnements ionisants.

Il importe de veiller à ce que la radioprotection de ces travailleurs soit assurée compte tenu des normes les plus récentes et de la libre circulation des travailleurs à l'intérieur des Communautés Européennes prévue dès 1993.

C'est pourquoi les exploitants et les industriels ont jugé nécessaire la mise en place d'une organisation certifiant la formation et le suivi du personnel exposé aux rayonnements ionisants.

CONTEXTE

Si l'on ne tient pas compte du milieu médical, 50 000 travailleurs de l'industrie française sont amenés à travailler sous rayonnements ionisants dont 30 000 exploitants et 20 000 autres travailleurs appartenant à près de 1 000 entreprises extérieures et qui interviennent pour des opérations de maintenance concernant en particulier près de 60 réacteurs électro-nucléaires en exploitation.

Les interventions lors des arrêts pour rechargement de ces réacteurs peuvent demander l'intervention de plusieurs centaines de personnes durant des périodes courtes mais avec des débits de dose ambiante pouvant dans certains cas atteindre, voire dépasser, 100 mGray/heure.

Plus de 80% des doses d'irradiation sont reçues lors de ces interventions par le personnel des entreprises extérieures et en 1990, 1 500 personnes ont reçu une dose annuelle supérieure à 20 mSievert.

Afin de minimiser la radio-exposition, il est fait appel à des équipements de plus en plus sophistiqués mis en oeuvre par des techniciens spécialisés, se déplaçant fréquemment sur les différents sites français ou étrangers et en particulier dans la Communauté Européenne.

Pour s'assurer du bon respect de la réglementation en vigueur dans le domaine de la radioprotection, a été créé en France en 1990, à l'initiative des industriels réunis au sein du Groupement Intersyndical de l'Industrie Nucléaire (GIIN) le Comité français de Certification des Entreprises Pour la Formation et le suivi du personnel travaillant sous Rayonnements Ionisants (CEFRI).

Ont été associés au sein du CEFRI, outre les employeurs de travailleurs de catégorie A ou B et les organismes de formations spécialisés en radioprotection :

- les exploitants, à savoir CEA, COGEMA et EDF,
- la Caisse nationale d'assurance maladie des travailleurs salariés (CNAMTS),
- Le Service central de protection contre les rayonnements ionisants (SCPRI),
- la Société française de radioprotection (SFRP).

Le Ministère du Travail et le Ministère de l'Industrie ont témoigné de leur accord et leur soutien à la création du CEFRI.

ROLE ET FONCTIONNEMENT

Les objectifs fondamentaux de la création du CEFRI sont au nombre de trois :

- contribuer pour le personnel à l'amélioration de la prévention des risques liés aux travaux dans les installations nucléaires,
- permettre aux entreprises françaises intervenant sur les marchés du nucléaire de faire la démonstration objective des actions de prévention qu'elles mènent,
- améliorer pour les entreprises françaises intervenant sur les marchés du nucléaire leur accès aux marchés européens et internationaux.

Les entreprises (employeurs) et organismes de formation ainsi certifiées s'engagent à respecter une spécification dont les bases sont les suivantes :

- pour l'employeur, désignation d'un responsable qui suit les opérations de recrutement, de contrôle médical, de formation et de surveillance dosimétrique du personnel de catégorie A ou B,
- pour l'organisme de formation, mise en place d'une organisation, de méthodes et de moyens de formation, d'un contrôle de connaissances des stagiaires à l'issue du stage, conformément à la spécification pour la formation du personnel de catégorie A ou B établie par le CEFRI.

Le CEFRI délivre un certificat valable 3 ans au vu d'audits réalisés dans les entreprises extérieures (employeurs) et organismes de formation. Ces audits s'assurent que l'organisation et les moyens mis en oeuvre sont en conformité par rapport à la réglementation française et aux spécifications du CEFRI.

Le CEFRI se compose d'un Comité de certification qui constitue l'instance de décision et d'une Commission technique qui qualifie les auditeurs et donne son avis au Comité sur les questions relatives à la prévention à la radioprotection et à la formation.

Le Comité a également qualité pour faire connaître la démarche française au plan européen et international et pour négocier tout accord international de réciprocité ou d'équivalence.

La structure et le fonctionnement du CEFRI ont été étudiés pour être conformes à la normalisation européenne s'appliquant aux organismes de certification des entreprises.

Lorsqu'une entreprise ou organisme demande à être certifié, le CEFRI lui adresse les spécifications à respecter et un questionnaire à remplir. A réception de la réponse à ce questionnaire et des pièces jointes, le CEFRI décide ou non, à la vue de ces documents, du lancement de l'audit. L'audit est effectué par deux personnes dont une au moins spécialisée en radioprotection.

Au vu du rapport d'audit, signé par les auditeurs et le responsable désigné de l'entreprise ou de l'organisme audité, le CEFRI délivre ou non son certificat ou le renouvelle pour une période de trois ans.

SITUATION

En 1990, ont été mis en place le Comité de Certification et la Commission Technique.

Cette dernière a mis au point les spécifications et les questionnaires pour les entreprises et organismes de formation.

En 1991, ont été recrutés et formés après une sélection sévère des candidats, plus de 40 auditeurs, la plupart expérimentés en radioprotection ou en technique d'audits.

Un grand nombre de demandes de certification ont été reçues, les premiers audits effectués et les premières certifications délivrées.

L'objectif actuel du CEFRI est d'avoir, d'ici fin 1992, certifié la plupart des grandes sociétés et organismes de formation intervenant en France dans ce domaine.

Il est envisagé par les exploitants de rendre obligatoire cette certification pour toute entreprise intervenante.

CONCLUSION

Avec le CEFRI, l'industrie nucléaire française, soucieuse de sa réputation, dispose du moyen de garantir la formation et le suivi des travailleurs exposés aux rayonnements ionisants tant sur le territoire national que lors d'interventions à l'étranger en particulier dans les différents pays de la Communauté Européenne.

Il lui semble souhaitable que ce type de certification soit généralisé et harmonisé entre les pays intéressés.

REFERENCES

- 1 - BNS/SFEN Congress Brussels, May 30-31, 1991
M. BOUSSARD Consequences for French reactors of the new ICRP recommendations
- 2 - SFRP - Surveillance de l'exposition individuelle, October 17-18, 1990.

oOo

U.S. Department of Energy
Office of the Assistant Secretary for Environment Safety and Health
Office of Epidemiology and Health Surveillance
Washington, DC 20585

The Role of CEDR in Worker Health Protection

The development of the Comprehensive Epidemiologic Data Resource (CEDR) is one of the major elements in the Secretary of Energy's initiatives to establish a credible state-of-the-art epidemiologic and health surveillance program in the Department of Energy (DOE). The aim of this program is to identify human health effects that may be associated with energy production and technology. The CEDR program being undertaken by the Department of Energy (DOE) will be the focus for organizing, integrating, and disseminating data from the DOE's epidemiologic activities. The CEDR information system will facilitate the acquisition, storage, access, and analysis of data collected from past and ongoing research, as well as from future activities. It is anticipated that substantial use of CEDR will be made by DOE staff, scientists at national labs, persons with university affiliations and public interest groups. The paper will describe the structure of the CEDR information system, the types of data being incorporated, the accessibility of the data and the uses being made of the data.

Prepared by: Barbara G. Brooks, CEDR Program Manager (301-353-4674)

DOSIMETRIE DU PERSONNEL : SES POSSIBILITES ET SES LIMITES

G. Wolber*, G. Coudert**, R. Dollo**, M. Bertin*

* EDF , DPT, Comité de Radioprotection, Paris, France

** EDF, SPT, Département Sécurité Radioprotection
Environnement, St Denis, France

PERSONNEL DOSIMETRY : CAPACITIES AND LIMITATIONS

Two dosimetric systems are implemented for EDF nuclear plant personnel : legal, with photographic films, and operational, with electronic dosimeters. They have similar detection thresholds and are designed for radioprotection purposes. Occupational exposure levels are comparable to natural irradiation. So, these data must be used cautiously for epidemiology.

INTRODUCTION

Les textes réglementaires sur la radioprotection en France prennent en compte les principes fondamentaux émis par la CIPR tels qu'ils figurent dans les directives européennes, à savoir l'optimisation et la limitation des expositions individuelles. La dosimétrie du personnel constitue un moyen essentiel d'assurer pour le travailleur le respect de ces deux principes. Par contre ses caractéristiques ne lui permettent pas d'utiliser ses résultats à des fins épidémiologiques sans prendre un certain nombre de précautions.

LES DEUX FORMES DE LA DOSIMETRIE DU PERSONNEL A EDF

Cette dosimétrie du personnel se présente sous deux formes : la dosimétrie réglementaire et la dosimétrie opérationnelle. Elle concerne uniquement l'irradiation par les rayons gamma, considérée à priori homogène du corps entier.

- La dosimétrie réglementaire

Elle est du type photographique à relevé mensuel. Elle contrôle à posteriori les expositions individuelles, vérifie le respect des limites individuelles autorisées et permet la détection du dépassement de ces limites. Elle a seule valeur médico-légale et relève de la compétence du SCPRI, organisme du Ministère de la Santé.

- La dosimétrie opérationnelle

Les résultats de la dosimétrie mensuelle réglementaire ne sont connus qu'à la fin du mois suivant [1] : ils ne permettent pas un suivi en temps réel des conditions d'exposition. La dosimétrie opérationnelle qui emploie des dosimètres électroniques à lecture directe

permet ce suivi en temps réel. Avec son dispositif d'alarme, elle assure une fonction de sécurité, mais son but principal est la dosimétrie analytique : gestion des doses individuelles, des doses collectives par chantier et par poste de travail et mettre en application le principe d'optimisation (Démarche ALARA).

SIGNIFICATION DES DOSES

Les doses reçues par le personnel sont très dispersées parce que les personnes sont affectées à des tâches spécifiques [2]. Mais ces doses sont en majorité faibles : 50% des doses annuelles sont inférieures à 0,5 mSv (50 mrem) [3]. Avec les seuils de détection propres à chacun des systèmes dosimétriques toutes ces doses ne sont pas toutes significatives, loin de là.

- Cas de la dosimétrie réglementaire

- Influence des seuils de détection :

La dosimétrie par film est obtenue par interpolation à partir de films étalons avec prise en compte d'un film témoin qui est censé enregistrer les doses hors zone contrôlée et pendant le transport des dosimètres.

L'incertitude sur la lecture des doses à partir d'un film est variable en fonction de la dose [4]. A 2σ , elle est de l'ordre de 0,12 mSv (12 mrem) à la dose zéro et de 0,9 mSv (90 mrem) à la dose de 5 mSv (500 mrem), soit une incertitude relative de 18%. Avec la composition des écarts-types, cela conduit à un seuil de détection S_D mensuel de 0,17 mSv (17 mrem) et une limite de détection L_D de 0,34 mSv (34 mrem). Cela veut dire que toute dose relevée à partir des films et inférieure à 0,17 mSv n'a pas de signification statistique et que ce relevé doit être supérieur à 0,37 mSv pour avoir 95% de chances de représenter une mesure.

Il s'en suit que les modalités de l'exposition et sa répartition dans le temps, liées au poste de travail, ont une influence sur la signification statistique des doses enregistrées. Si l'on part de l'hypothèse d'une exposition à débit de dose constant :

- 0,5 mSv (50 mrem) cumulé sur 2 mois est significatif (Incertitude : 0,24 mSv).
- 0,5 mSv cumulé sur 12 mois n'est pas significatif (Incertitude : 0,59 mSv).
- 0,5 mSv par an cumulés sur 30 ans, soit 15 mSv (1,5 rem), sont largement significatifs (Incertitude : 3,22 mSv).

Les données annuelles sur les faibles doses n'ont pas de signification statistique : il faut des durées

d'observation de l'ordre de 5 ans pour disposer de résultats utilisables en épidémiologie.

- Influence des modalités de prise en compte des doses.

Le seuil de prise en compte des doses est actuellement de 0,1 mSv (10 mrem). Avec une limite de détection de 0,34 mSv, on peut déclarer nulles les doses inférieures à cette valeur : cela a une influence relativement faible sur les doses collectives mais on perd toute information sur les cumuls individuels des doses sur la vie professionnelle.

- Cas de la dosimétrie opérationnelle

Les dosimètres électroniques ont un mouvement propre de 20 μ Sv (2 mrem) par jour et ils n'enregistrent que des doses supérieures à 10 μ Sv (1 mrem). Le temps moyen de séjour d'un travailleur en zone contrôlée est d'environ 3h par entrée où il y a, au maximum, 2 entrées journalières. Dans l'hypothèse d'une exposition à débit de dose constant et pour une quarantaine d'entrées par mois, la dose cumulée minimale détectée dans le mois est de l'ordre de 0,15 mSv, équivalente à celle des films. La dosimétrie opérationnelle ne permet pas de lever les doutes sur les faibles doses.

- Possibilités des systèmes dosimétriques

Les faibles doses annuelles ne peuvent être que des repères : quel que soit le système utilisé, seul leur cumul sur plusieurs années constitue des données statistiquement fiables. L'emploi de dosimètres individuels nominatifs à mémoire, en abaissant le seuil de détection d'un facteur au moins égal à 4, est un des moyens de rendre les faibles doses annuelles significatives.

FACTEURS DE RISQUE A PRENDRE EN COMPTE DANS L'EVALUATION DE L'IRRADIATION DU PERSONNEL

L'irradiation du personnel des centrales nucléaires pendant le travail, avec une moyenne de 2 mSv par an, est de l'ordre de grandeur des irradiations non professionnelles : l'irradiation médicale et l'irradiation naturelle.

- L'irradiation médicale : en dose efficace, elle est en moyenne de 1 mSv, avec des variations d'un facteur 3 d'un pays à l'autre et d'un facteur 2,5 d'une région à l'autre en France.

- L'irradiation naturelle : avec une dose efficace moyenne annuelle de 2,4 mSv, elle varie en France d'un facteur 3 d'une région à l'autre.

Ces facteurs introduisent un biais dont il faut tenir compte dans les enquêtes épidémiologiques. Si l'irradiation naturelle est relativement facile à estimer, l'irradiation médicale est d'accès plus difficile : elle est individuelle, couverte par le secret médical, avec une dosimétrie approximative du fait des incertitudes de toute enquête rétrospective sur ce sujet.

CONCLUSION

La dosimétrie du personnel à EDF est conçue dans un but de radioprotection : elle permet de gérer les doses par des procédures relevant du principe d'optimisation et de s'assurer que les limites individuelles ne sont pas dépassées. Elle apporte des informations utiles aux enquêtes épidémiologiques mais elle a ses limites et il faut être prudent quant à leur usage.

REFERENCES

[1] WOLBER G. - Programme de traitement des films dosimètres utilisé dans le traitement informatique de la dosimétrie individuelle du personnel à EDF. (Note interne EDF, D87 - D17134). EDF - DPT - Comité de Radioprotection, 1982, 43p.

[2] ROLLIN P., BERTIN M. Dosimétrie en centrale nucléaire - Facteurs influençant les doses. In : " Radiation, Fields, Currents, . 10th Int. Symposium of the Int. Section of the ISSA for the Prevention of Occupational Risks Due to Electricity. Wien. Autriche. 21-23/11/1990 ". (ISSA, Ed.). Genève, Suisse, 1991, 40-43.

[3] DOLLO R. - Bilan dosimétrique du personnel des centrales nucléaires en 1988 - Radioprotection, 1990, 25, 65-70.

[4] COUDERT G. - Précision des dosimètres - Intercomparaison film - dosimètre électronique. (Note interne EDF, D584-SRE/TM-90). EDF - SPT - Département Sécurité, Radioprotection, Environnement, 1990, 39p.

REFLEXIONS SUR UNE METHODE PRATIQUE D'UNIFORMISATION DE LA COMPTABILISATION DES DOSES

P. BOUSSARD, R. DOLLO

ELECTRICITE DE FRANCE - DSRE

M. DE KERVILLER, M. PENNEROUX

COMMISSARIAT A L'ENERGIE
ATOMIQUE - FRANCE

IDEAS ON A PRACTICAL METHOD TO MAKE MORE UNIFORM THE MEASURE AND THE ACCOUNT OF DOSES

ABSTRACT : The CIPR 60 publication and its consequences on the revision of CEC regulations and basic norms, discussions on dosimetry of outside workers and more generally on the development of exchanges of information between users have led EDF to question its practices for measuring counting doses. Faced with this wide range of french practices and in a desire for harmonisation, an EDF and CEA work team has established a summary of present methods, an evaluation of the consequences of these different strategies and have then suggested a harmonisation of dosimetric measures based on systematic methodology.

1 - INTRODUCTION

Si la mesure et la comptabilisation des doses corps entier dues au rayonnement γ est en général bien comprise par les exploitants, la dosimétrie due aux autres types de rayonnement (neutron, α , β) ou à des voies d'exposition différentes (dose peau, doses aux extrémités, exposition interne) a toujours fait l'objet de nombreuses interrogations. Cependant, même la dosimétrie corps entier suscite encore des questions suite, par exemple, aux écarts constatés entre la dosimétrie réglementaire (film) et la dosimétrie opérationnelle (électronique).

Le développement du parc de réacteurs nucléaires français, l'apparition de nouvelles sources d'exposition (combustible MOX) ou le vieillissement des tranches ont renforcé ces interrogations. Parallèlement, les études comparatives avec les centrales étrangères, le suivi dosimétrique des travailleurs extérieurs et en particulier des travailleurs transfrontaliers ont conduit EDF à réfléchir sur la pertinence des informations ou la validité des choix effectués au début du lancement du programme nucléaire français, voire antérieurement.

C'est pourquoi un groupe de travail mixte EDF-CEA s'est attaché, courant 1991, à comparer ses pratiques, les évaluer et proposer une harmonisation des méthodes de mesures.

2 - BILAN DES PRATIQUES A EDF ET DANS LE GROUPE CEA

Au sein du parc des centrales REP d'EDF, une très forte cohérence est observée par suite de sa standardisation. En revanche, une grande variété existe si l'on compare EDF et les différentes filiales du groupe CEA. Les moyens de surveillance individuels et collectifs sont différents suivant les catégories de travailleur (A, B ou non exposés), les types de détecteurs sont également différents (film, thermoluminescence, etc.) et enfin les fréquences de traitement et la nature des enregistrements varient également.

Cette diversité est due à la fois à la nature des risques propres aux activités des sites concernés, mais également à des choix de stratégie dosimétrique.

3 - MISE EN PLACE D'UNE METHODOLOGIE STRATEGIQUE GLOBALE DE LA DOSIMETRIE ET EVALUATION DES DIFFERENTS CHOIX POSSIBLES

Une conception globale de la dosimétrie repose sur une évaluation des doses qui doit prendre en compte les aspects suivants :

- A quel usage est destiné la mesure (respect des limites individuelles, analyse dosimétrique de chantier ou études épidémiologiques) ?
- Quels sont les types de rayonnement réels ou potentiels auxquels sont soumis les travailleurs ?
- Parmi ces rayonnements, quels sont ceux qui méritent un suivi individuel actif (en temps réel) ou passif (en temps différé), un suivi collectif actif ou passif ?
- Parmi ces rayonnements, quels sont ceux qui ne méritent pas de suivi, mais simplement une évaluation calculée, associée ou non avec une détection d'alarme ?
- Avec quel type de détecteur le suivi est-il réalisé ? Comment est-il étalonné ? Quel est le pas de la mesure ?
- Quel est le seuil d'enregistrement, c'est-à-dire l'équivalent de dose au-dessus duquel le résultat de la mesure présente un intérêt suffisant pour valoir d'être enregistré et conservé ?
- Quel est le pas d'enregistrement ? Comment est fait l'arrondissement ?
- Comment sont enregistrées les expositions internes (à la date de l'exposition ou étalées dans le temps) ?
- Quelles données élémentaires sont conservées ?
- Quels traitements de données sont effectués (cumuls dans le temps, cumuls de doses efficaces, contrôle de dépassement des limites) ?
- Quels types de conservation et d'archivage utilise-t-on ?

- Quelle utilisation des résultats est effectuée, vis-à-vis des doses des travailleurs de l'exploitant comme de ceux des entreprises extérieures ? Quelles études statistiques sont effectuées et quelle diffusion leur est-elle accordée ?

La réponse à l'ensemble de ces questions constitue la stratégie dosimétrique retenue et EDF a essayé, pour quelques domaines, d'évaluer les conséquences d'autres options que celles actuellement utilisées en centrales nucléaires.

Le tableau ci-dessous montre par exemple (pour la dosimétrie réglementaire film), les variations de la dose collective des agents EDF en 1990 en fonction du seuil d'enregistrement, par rapport à la valeur de 27,9 Sv obtenue avec le seuil de 0,10 mSv actuellement utilisé à EDF.

Seuil d'enregistrement	Dose annuelle non enregistrée		Répartition de la dose annuelle individuelle (12 mois consécutifs) avec le seuil d'enregistrement à 0,1 mSv		
	en mSv	en Sv	en % dose totale	dose en mSv entre	Nombre d'agents
0,2	2,42	8,7	0 et 0,04	3112	19,6 %
0,3	4,10	14,7	0,05 et 0,14	2475	15,5 %
0,4	5,57	19,9	0,15 et 0,24	1458	9,2 %
0,5	6,91	24,7	0,25 et 0,34	905	5,7 %
			0,35 et 0,44	624	4,0 %
			0,45 et 0,54	423	2,7 %
			> à 0,55	7000	43,3 %

Le simple choix d'un seuil d'enregistrement à 0,1 ou 0,5 mSv fait donc varier la dosimétrie globale des agents EDF de 25 %.

4 - PROPOSITION D'HARMONISATION DES STRATEGIES DOSIMETRIQUES

Les raisons qui ont guidé les choix de stratégie dosimétrique, lors du développement de l'industrie nucléaire française ont privilégié les aspects spécifiques et locaux, ce qui explique les écarts constatés dans les pratiques des exploitants. Par ailleurs, l'utilisation de la dosimétrie résidait essentiellement dans la vérification du respect des limites individuelles.

Aujourd'hui, les échanges d'information, la circulation de nombreux travailleurs de site en site, le suivi des personnels changeant d'entreprise, nécessitent une plus grande harmonisation de l'enregistrement et de la comptabilisation des doses.

C'est pourquoi, le groupe de travail EDF/CEA a proposé dans un premier temps les mesures suivantes :

- étalonnage des dosimètres film selon la norme ICRU,
- valeur du pas de la dosimétrie opérationnelle de 0,01 mSv pour les détecteurs électroniques et de 0,05 mSv pour les TLD (Détecteur par thermoluminescence),
- valeur du pas de la dosimétrie film réglementaire et mensuelle de 0,1 mSv,
- seuil d'enregistrement par lecture pour une entrée en zone contrôlée de 0,01 mSv (ce seuil fait partie du cahier des charges pour les constructeurs de détecteurs),
- seuil d'enregistrement mensuel pour la dosimétrie film réglementaire de 0,2 mSv.

Par ailleurs, une revue des stratégies dosimétriques sera effectuée en particulier dans certains domaines (dose neutronique, dose peau, dose aux extrémités, radon). L'objectif est de définir l'ensemble des éléments à mesurer ou contrôler, puis à enregistrer et conserver.

Ces éléments constitueront une base de gestion analytique fine des données dosimétriques. Enfin, une sommation globale des doses efficaces permettra d'obtenir un indicateur unique d'évaluation globale de la dosimétrie individuelle et collective, même si cet indicateur présente peu d'intérêt sur le plan strictement médical.

5 - CONCLUSION

Les différentes pratiques observées dans la gestion des doses laissent à penser que des écarts dans les doses comptabilisées peuvent varier dans des proportions allant jusqu'à 50 %.

Cependant, la réduction des normes de base, le suivi au plus près des doses dans la mise en oeuvre de politiques ALARA, la prise en compte de nouvelles expositions, les échanges d'information conduisent les exploitants à mieux définir ce qui est pris en compte dans les valeurs annoncées et donc d'harmoniser leurs pratiques. La mise en place d'un indicateur global utilisant la somme des doses efficaces apparaît à ce titre indispensable.

Le travail réalisé entre EDF et le CEA a permis à cette occasion de mieux appréhender, dans leur globalité, les options qui avaient été prises (au moins implicitement) dans leurs stratégies dosimétriques, et la méthodologie mise en place donne une grille d'application utilisable pour toute révision de ces stratégies.

³²P PERSONNEL MONITORING IN U.S. RESEARCH INSTITUTIONS

Victor N. Evdokimoff

Boston University Medical Center
Radiation Protection Office
88 East Newton St.
Boston, Ma. 02118

ABSTRACT

Phosphorus-32 is used extensively in medical research. Because our ³²P personnel monitoring costs are significantly increasing especially for low exposure potential < 37 MBq, we surveyed 13 similar U.S. institutions to aid a review of our present badge policy. Our 3 year exposure data show that the extremities have a greater potential for exposure than the skin of the whole body. Despite significant costs, fifty-four percent of institution surveyed issued only a whole body badge for use < 37 MBq. Liability and registration are reasons other than exposure potential to monitor at < 37 MBq. Almost all issued a whole body badge and ring badge at 37 MBq.

INTRODUCTION

BUMC MONITORING AND COSTS FOR ³²P

Individuals using less than 37 MBq (1 mCi) of ³²P are issued a commercial TLD finger ring badge worn name side at the palm to assess extremity dose. Individuals using 37 MBq or more of ³²P are also issued a whole body film badge to assess the dose to the skin of the whole body.

In reviewing 3 years of exposure data for ³²P users through December 1989, the highest annual whole body badge dose was 5.1 mSv (510 mRem). For our ring badges, 25% had positive readings above the minimum detectible exposure at < 37 MBq ³²P use and 32% positive at 37 MBq and above. Our whole body badges had 12% positive exposures at 37 MBq and greater.

From 1987 to 1989, our ³²P badge costs have doubled accounting for 55% of all badges issued for radioisotopes. In 1990, our annual badge cost was over \$12,000 with approximately 35% of these costs due to issuing badges for ³²P use less than 37 MBq.

SURVEY

Our office contacted by telephone the health physics offices of 13 selected institutions throughout the United States known to have large broad scope or broad medical radioisotope licenses. These institutions were asked their policy for personnel monitoring of persons using only ³²P.

SURVEY RESULTS

Of the 13 institutions surveyed, 69% issued whole body badges for ^{32}P use < 37 MBq. At the 37 MBq level, 100% of the institutions surveyed issued a whole body badge and 77% issued a ring badge. At the 37 MBq level, four institutions that did not issue a badge at less than 37 MBq did issue a whole body badge and ring badge at the 37 MBq level, suggesting this as an action level for personnel monitoring.

Reasons given for issuing badges at < 37 MBq include: assess exposure potential, registration and protection from liability. Reasons for not issuing badges at < 37 MBq include: cost, low exposure potential, and because their health physics department surveys ^{32}P use.

Some institutions were unclear whether the whole body badges were assessing whole body ^{32}P exposure or skin of the whole body exposure.

CONCLUSION

1) Phosphorus-32 exposures at less than 37 MBq (1 mCi) appear to have a low exposure potential to researchers and are not likely to approach the current USNRC criteria of monitoring at 25% maximal permissible dose. However, determining what that dose is, i.e., skin vs. whole body, is not entirely clear from this preliminary survey of 13 institutions. In our opinion, the skin is at risk and the skin dose limit should apply.

2) The majority of the institutions surveyed issued a whole body film badge for less than 37 MBq ^{32}P use and a whole body film badge with a TLD ring badge at 37 MBq or greater ^{32}P use. There was a greater degree of uniformity in personnel monitoring for ^{32}P at levels of 37 MBq and greater.

3) Liability and registration are reasons other than exposure potential that some institutions issue a whole body badge to investigators using less than 37 MBq.

4) Should an institution decide to issue a badge for ^{32}P use under 37 MBq, it would be more appropriate to issue a ring badge worn with the name side at the palm to monitor extremity dose than to issue a whole body badge (32% versus 12% positive).

5) Should an institution decide to issue a badge for ^{32}P use under 37 MBq, the costs may be significant.

REFERENCES

1. USNRC, 1990, Code of Federal Regulations, Washington, D.C.: U.S. Government Printing Office; 10 CFR Part 20.
2. Evdokimoff, Victor, 1991, Phosphorus-32 Personnel Monitoring in Research Institutions, Health Physics 61, pp. 275-278.

CENTRAL INDEX OF DOSE INFORMATION (CIDI)

W.J.Iles, K.A.Fillary, E.Greenslade, G.M.Kendall, T.O.Marshall
National Radiological Protection Board (NRPB)
Chilton, Didcot, Oxon, U.K.

W.P. Bines, M.Williams
Health and Safety Executive (HSE)
London, U.K.

ABSTRACT

This paper describes the functions, operation, types and method of data transfer, and summarised data to be published relating to the Central Index of Dose Information.

INTRODUCTION

The Central Index of Dose Information (CIDI) is a national database of occupational exposure to radiation operated by the National Radiological Protection Board (NRPB) as agent for the Health and Safety Executive (HSE). It receives annual summaries from Approved Dosimetry Services (ADSs) of the radiation doses to classified persons in the United Kingdom. At present, there are approximately 40 dosimetry services approved in Great Britain for keeping records and approximately 60,000 classified workers. All the data provided to CIDI are treated as confidential with respect to individual persons and employers.

FUNCTIONS OF CIDI

CIDI has a number of functions as listed below:-

- (a) To enable data to be transmitted from the previous ADS to the next, when a classified worker changes employer.
- (b) To provide an index to show which ADS is responsible for the monitoring of a classified person, allow revised dose data to be passed from one ADS to the next, and to act as a back-up source of dosimetric information about the person.
- (c) To conduct an annual audit of the persons monitored by an ADS to ensure that the number of persons monitored agrees with the total for the previous year, allowing for additions and deletions during the year.
- (d) To provide statistics to guide policy making on a national basis.

TYPES OF RECORD EXCHANGED BETWEEN CIDI AND ADSs

Registration report: This is sent from an ADS to CIDI to notify CIDI that a dose record is being started by the ADS for a classified person.

Entry report: This is sent from CIDI to the ADS to notify the ADS that CIDI has started a record for the classified person.

Termination report: This is sent from the ADS to CIDI to inform CIDI that a classified person has left employment, and should be sent to CIDI as soon as possible after all outstanding dosimeters have been processed.

Annual return: This is sent from the ADS to CIDI and includes

summaries of the annual doses received by all classified workers for which the ADS kept records, irrespective of whether they ceased to be classified during the year. Note: a person can only be declared as having ceased classified work at the end of the year.

Amended records: These are records that are sent from the ADS to CIDI to correct previously submitted information. It is recognised that records may need to be provided occasionally, but amendments should be exceedingly rare in order to minimise the operating costs of CIDI.

In addition to the above, the ADS has to inform CIDI of the name and address of any employer for whom the ADS is keeping records. CIDI then allocates to the ADS a CIDI code number for that employer.

DOSE DATA FOR CIDI

The following is a summary of the dose data contained within the annual return, termination report and entry report. Precise details of the dose data and personal data are contained in The Reference Manual for Data Transfer to CIDI'. Not all the data are obligatory.

Current year dose data:

(a) Sum of effective dose equivalent from external radiation and committed effective dose equivalent from internal emitters.

(b) Neutron component of (a).

(c) Notional component of (a) (where this exceeds 10% of the total).

(d) Sum of dose equivalent from external radiation and committed dose equivalent from internal emitters to organs and tissues (where doses exceed 10% of the proportion of the annual dose limit for the period in question).

(e) A flag if (a) above includes a component from long-lived or other internal emitters.

Lifetime dose data:

(a) Effective dose equivalent from external radiation (including (b) below).

(b) Notional component of (a) (where this exceeds 10% of the total).

Note: Termination and entry reports will now be required to include separate dose summaries for each of the previous four years (excluding any year before 1/1/88).

PERSONAL DATA FOR CIDI

The personal data sent to CIDI includes the following:-

(a) Surname and forenames.

(b) Sex and date of birth.

(c) National insurance number (the unique identifier).

(d) Identifier of the ADS supplying information.

(e) Occupational classification of the employee.

(f) CIDI code number of the individual's employer.

(g) Date of commencement/termination of classified work in this employment.

(h) Employers work activity coded as Standard Industrial Classification (1980).

METHOD OF DATA TRANSFER

It is intended that the majority of data will be transmitted to and from CIDI in the form of magnetic media i.e. magnetic tape or floppy discs depending on the amount of data, in accordance with precisely defined data formats¹. In addition to the previously defined data, each computer compatible record has a field for: record type, record counter, record key, and amendment flag. The computer dose record(s) have a field to distinguish whether the record is for doses for the current year or lifetime doses, and fields that describe the dose type and organ/tissue type as per CIDI classification.

PUBLICATION OF CIDI DATA

Although the individual data on the database are treated as confidential, an annual summary of statistics for each year, commencing for the year 1986 will be published. In order to facilitate comparison between years, it is the intention that wherever possible, the format of succeeding summaries will remain unchanged. Also, in addition to these annual summaries, it is expected that further analyses will be published at likely intervals of five years that will assist in the identification of any trends.

The tabulated data is divided into three parts; Part A - Whole body doses, Part B - Dose variation with age and sex, and Part C - Doses to specific organs and tissues. A common feature of the tabular presentation is that all doses are related to Occupational Category. The majority of the tables present the data distributed within dose intervals, together with total workers, collective doses, and mean doses for each Occupational Category. There is also a table that gives the distribution of workers, by age and sex, that exceeded 15 mSv for the year.

As a matter of policy, the statistical summary includes a minimum of analysis. This is in order to ensure that any subsequent analysis of data will be based on the "raw" data as received by CIDI. However, there is an additional table that gives the distribution of effective dose equivalent plus committed effective dose equivalent where pro-rata doses have been substituted for notional doses. The reason for this is that it is believed that such a table is likely to give a more realistic impression of actual doses.

Figures 1 to 3 are taken as examples from the 1986 Summary of Statistics², they show respectively, mean doses, the number of workers exceeding 15 mSv, and collective doses per Occupational Category.

REFERENCES

1. Greenslade, E., Kendall, G.M., Iles, W.J., Gardner, P.H., Young, T.O. Reference Manual for Data Transfer to the Central Index of Dose Information, 1989, NRPE-M176.
2. Summary of Statistics 1986, The Central Index of Dose Information, HMSO (to be published).

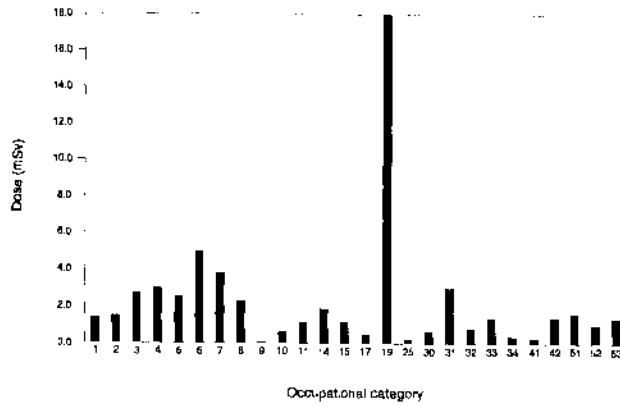

FIGURE 1 Mean dose per occupational category

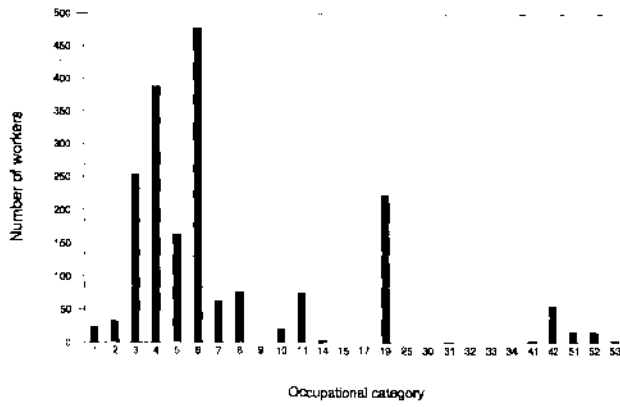

FIGURE 2 Workers exceeding 15 mSv per occupational category

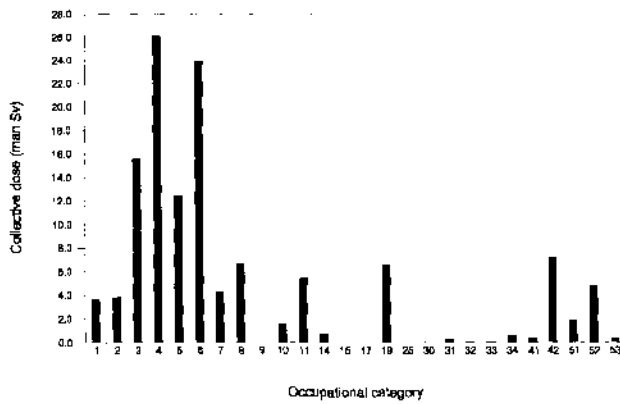

FIGURE 3 Collective dose per occupational category

IMPACT OF ICRP60 ON DOSES RECEIVED BY OCCUPATIONAL EXPOSED WORKERS IN EDUCATIONAL ESTABLISHMENTS IN THE UNITED KINGDOM

A. G. RICHARDS
RADIATION PROTECTION SERVICE
UNIVERSITY OF LEEDS
UNITED KINGDOM.

ABSTRACT

The doses received by University workers lie generally in the range 1-3 mSv. This paper discusses how the doses received by workers can be kept down by considering the changing working practices in laboratories with the revised dose limits and annual limits on intake.

INTRODUCTION

The International Commission on Radiological Protection (ICRP) in 1977 published its recommendations known as ICRP26.¹ Following the publication of ICRP 26 the Commission of the European Communities issued the Euratom Directive in 1980.² This directive is binding on all the countries in the European Economic Community (EEC) but has no legal status for countries outside the EEC.

The Euratom Directive required the members countries to produce requirements governing persons exposed to sources of ionising radiations. In the United Kingdom these requirements were implemented by means of the Ionising Radiations Regulations 1985 (IRR 85),³ under the Health and Safety at Work Act⁴. These regulations are only legally binding in the United Kingdom. They set out rules relating to the employment of workers who use ionising radiations. In addition certain duties are imposed on manufacturers of equipment or articles to ensure that any article is constructed to restrict so far as is reasonably practicable exposure to ionising radiations. There are certain exemptions to these regulations for members of the armed forces and to work for the Secretary of State for Defence.

Persons who are exposed to ionising radiations in the course of medical treatment are covered by different regulations.⁵

Under the Ionising Radiations Regulations a worker who is likely to receive three tenths of any relevant dose limit shall be designated a classified worker. A requirement of the IRR85 is that a dosimetry service used for the measurement of doses received by classified workers be approved. These services known as Approved Dosimetry Services (ADS) are approved by the body in the UK called the Health and Safety Executive. ICRP 60⁶ recommendations differ from ICRP26.

DOSE LIMITS

DOSE LIMITS IN ICRP60	OCCUPATIONAL	PUBLIC
Effective dose	20 mSv per year (i) averaged over 5 years	1 mSv per year.
Annual equivalent dose		
in the lens of the eye	150 mSv	15 mSv
the skin	500 mSv	50 mSv
the hands and feet	500 mSv	

Figure 1: ICRP 60 DOSE LIMITS

(i) The further provisions that the effective dose should not exceed 50 mSv in any single year.

The whole body doses received by workers in educational establishments are on average less than 2-3 mSv⁻¹ and since the introduction of the IRR 85 the mean dose is now much lower as the

data provided by an ADS shown in figure 2 and figure 3 indicates.

	0 - 5 mSv	5 - 15 mSv	15 - 50 mSv	Man mSv
University staff	1394	10	16	568

Figure 2: 1986 Dose Statistics

	0 - 5 mSv	5 - 15 mSv	15 - 50 mSv	Man mSv
University staff	1537	3	4	134

Figure 3: 1989 Dose Statistics

Clearly ICRP60 can not have too much effect on doses received by University workers⁷ and different criteria other than dose received would be needed to decide which groups to monitor.

Occupational Exposure of Women

The basis of control of occupational exposure of women who are not pregnant is the same as for men. If a woman is pregnant then additional control has to be taken. The effects on the unborn child from the 3rd week after conception are deterministic in effect and are estimated from animal experiments to have a threshold of 100 mGy⁸ but there is no definite evidence for the susceptibility of the human foetus. ICRP have decided that once the pregnancy has been declared the dose limit to the surface of the abdomen should be 2 mSv for the remainder of the pregnancy. Essentially pregnant women should not carry out high risk tasks.

Equivalent dose to the surface of the womens abdomen	$\leq 2 \text{ mSv}$
intake of radionuclides	$\leq \frac{1}{20} \text{ ALI}$

In Universities in the UK a small number of workers carry out work on cyclotrons and accelerators. The largest number undertake work with open sources or sealed sources and x-ray crystallographic work. A requirement of the UK Ionising Radiations Regulations is that for certain categories of work the employer appoints a Radiation Protection Adviser (RPA)

Should the adviser restrict the pregnant workers to $\frac{1}{20}$ ALI when handling open sources? or what criteria should an adviser use in relation to pregnant workers. Lets look at the implications of restricting the work $\frac{1}{20}$ ALI.

COMPARISON OF THE ACTIVITIES OF THE FIVE MOST COMMON RADIONUCLIDES USED IN UK UNIVERSITIES WITH $\frac{1}{20}$ ALI

	Activity in common use Bq	$\frac{1}{20}$ ALI Bq
³ H	1×10^{11}	5×10^7
¹⁴ C	1×10^7	2×10^6
³² P	$10^6 - 10^9$	4×10^5
³⁶ S	$10^6 - 10^8$	5×10^6
¹²⁵ I	$10^6 - 10^8$	5×10^4

Figure 4: Activities of common radionuclides

With the exception of Carbon 14 and some experimental work with Phosphorous 32 and Tritium most other work would be precluded if the level of $\frac{1}{20}$ ALI marked the upper limit for a pregnant worker to handle.

Work of Pregnant Employees in relation to external radiation.

A very small number of workers in the UK Universities are cyclotron workers. Pregnant workers may be exposed to an external radiation hazard when handling open/closed sources or when carrying out x-ray crystallography with the interlocks overridden. The risk of exposure needs to be considered in each case.

Large sealed sources which are housed in irradiation units or similar enclosures usually produce a very small risk and thereby would not present a problem in relation to pregnant workers.

Most problems are likely to occur in relation to the handling of open sources of radionuclides by pregnant workers.

Classification of Working Areas/Workers

ICRP 26 defined Working Conditions A, Working Conditions B and then went on to introduce the classification of the work place as Controlled Areas and Supervised Areas for these conditions. In line with ICRP 26 and the Euratom Directive the UK legislation defined **Classified Workers**.

The criteria for designating a controlled area as set down in UK legislation "is essentially an area is designated controlled if the dose rate is likely to exceed $7.5\mu\text{Sv}\cdot\text{h}^{-1}$ " The occasions when dose rates above this level are encountered have been considered in relation to pregnant workers. Generally whole body doses are negligible and extremity doses small.

Work with some machine sources and irradiation units may present a problem. The handling of some sources will generate dose rates above $\mu\text{Sv}\cdot\text{h}^{-1}$ but generally these sources can be dealt with by the use of remote handling tools and shielding as at present. Clearly this is working in the case of UK Universities as the whole body doses demonstrate. The ALARA principle is practised quite well.

Designation of Areas in Relation to Internal Radiation

The UK legislation requires that an area is designated as controlled in respect of internal radiation if there is a risk of airborne contamination or surface contamination above specified levels and the quantities in use are greater than 10 Annual Limits on Intake (ALI).⁹

Contamination above the levels specified are not found on a regular basis in UK Universities and other criteria have to be used to designate an area as controlled. Once an area is however designated as controlled it then becomes subject to the legal requirements relating to access.

One way forward which is being considered in relation to designating controlled areas in UK Universities is to consider the total activity handled.

There have been attempts in the past to relate the activity taken into the body to the activity being handled. A factor of 10^{-3} of the activity handled as an average could be used. Clearly this factor will be governed by the circumstances under which the activity is handled. Using this principle and restricting the intake to 1/10 ALI.

Laboratories would be designated a controlled area if the activity handled exceeded 100 ALI.

Using the criteria of 100 ALI very few laboratories in UK universities would need to be designated controlled areas. These would be the few laboratories that work with tritiated water in large quantities or where ^{32}P is used in hybridisation experiments or where perhaps iodinations are carried out.

ICRP 60 AND THE CLASSIFICATION OF WORKING AREAS

The Commission in the 1990 recommendations now regards the distinction between controlled and supervised as being too arbitrary. Not all workers in controlled areas received doses above 3/10ths of the occupational dose limit. Certainly workers in educational establishments do not receive doses above this figure whether in controlled or supervised area. ICRP now regard the decision in relation to area classification is better taken at a local level.

One aspect is quite clear that outside an area designated for occupationally exposed persons the

doses received should be below the dose limit for public exposure of $1\text{mSv}\cdot\text{y}^{-1}$. This dose is not measured easily and so it is difficult to implement.

ASSESSMENT OF DOSES

In UK Universities the practice of which workers to classify does vary. Whole body external doses are monitored in the usual way, urine monitoring being undertaken for a small number of high activity Tritium workers. Non-classified workers are generally also monitored although not required it provides reassurance to the worker.

ICRP 60 recommends that monitoring for external radiation is used for all who are occupationally unless it is clear that their doses will be consistently low.

Now we know that the doses occupationally exposed workers in UK universities receive are low because we monitor them already. The data accrued helps establish the designation of the working areas. So perhaps we should consider monitoring all radiation workers routinely!!

TRAINING

ICRP 60 suggests that the most important factor in implementing the recommendations is training. A substantial commitment should be undertaken by all educational establishments to training. This should include radiation protection advisers, radiation protection supervisors, and workers.

CONCLUSIONS

The implementation in the UK of the ICRP recommendations will not lead to a general reduction in doses. Careful consideration by the Regulatory authority of some of the problems posed will be needed, such as occupational exposure of pregnant workers and classification of areas. Better management of occupational exposure should result.

REFERENCES

1. ICRP Publication No. 26 Recommendations of the International Commission on Radiological Protection Vol.1, 3 1977.
2. Council Directive of the European Communities 80/836/Euratom Official Journal No. L246 Vol.23, 17.9.1980.
3. The Ionising Radiations Regulations 1985 No. 1333. Her Majesty's Stationery Office, London, ISBN 011-057333-1.
4. Health and Safety at Work Act 1974.
5. The Ionising Radiation (Protection of Persons Undergoing Medical Examination or Treatment) Regulations 1988, No. 778. Her Majesty's Stationery Office, London.
6. ICRP Publication No. 60 1990 Recommendations of the International Commission on Radiological Protection ISSN 0146-6453.
7. Personal Communication from Dr. P.J. Roberts, Department of Medical Physics, Southampton General Hospital, U.K.
8. ICRP Publication No. 61 Annual Limits on Intake of Radionuclides by Workers based on the 1990 Recommendations ISSN 0146-6453, Vol. 21 No. 4.

CUMULATIVE RADIATION EXPOSURE AT BNFL SELLAFIELD:
A HISTORICAL PERSPECTIVE

K BINKS, R WAKEFORD, R STRONG, D J COULSTON

British Nuclear Fuels plc, Risley,
Warrington, Cheshire, WA3 6AS, U.K.

ABSTRACT

The temporal distribution of the average cumulative whole body annual recorded external radiation doses of 15,182 monitored male Sellafield employees is presented. Results are given for successive pairs of years of first monitoring, from 1949-50 to 1985-86, and for successive single years of follow up for each of these cohorts. The results show: there is a reduction in average cumulative dose with later years of first monitoring at any length of follow up; a marginal reduction in the increase in the average cumulative dose for any given cohort with longer length of follow up; and the pattern of average dose in the first year of follow up is similar to that previously reported, in [1].

INTRODUCTION

Historical annual recorded whole body dose data for Sellafield employees were computerised as a special exercise by a dedicated team of British Nuclear Fuels plc (BNFL) Sellafield staff in the late 1970's. This computerised annual dose database has had the annual dose data for all Sellafield employees added to it up to 1986. These dose data together with personnel and tracing return data form part of the BNFL Company Epidemiology database and are held on computer in the Company Medical Office at the Sellafield site. Extracts from the Epidemiology database have been supplied to researchers for use in a range of studies, published and forthcoming eg. [1,2,3,4]. The Sellafield employee data have been combined with equivalent data for the Atomic Energy Authority (AEA) and the Atomic Weapons Establishment (AWE) by Harwell staff to form the Nuclear Industry Combined Epidemiological Analysis (NICEA) database. These data, which will be analysed by epidemiologists at the London School of Hygiene and Tropical Medicine (LSHTM), have been transferred to the International Agency for Research on Cancer (IARC) for combining with American and Canadian data, for analysis by IARC staff.

THE DISTRIBUTION OF ANNUAL EXTERNAL DOSE DATA

The Sellafield whole body annual dose data are, as with other such data [5], in their own right of considerable epidemiological interest. There are 15,182 male radiation workers on this database who have been occupationally exposed to 1307 Sv during 112,582 person years of employment. Only the first episode of continuous employment as a monitored worker and those annual external doses recorded during that employment period are used for the results of this paper.

AVERAGE CUMULATIVE ANNUAL EXTERNAL WHOLE BODY DOSES IN mSv (UPPER
 SUCCESSIVE PAIRS OF YEARS OF FIRST MONITORING, STARTING IN 1949-50,
 OF ALL AGES WHILE CONTINUOUSLY MONITORED DURING THEIR FIRST EMPLOYMENT

Year of first monitoring	Years of follow-up								
	1	2	3	4	5	6	7	8	9
49-50	2.3	7.3	30.8	59.5	83.8	109.7	143.9	178.8	200.7
51-52	6.9	26.7	45.7	62.9	82.8	106.4	127.2	141.1	158.2
53-54	10.1	24.8	42.9	64.0	81.2	96.1	114.4	134.5	150.3
55-56	8.9	28.4	44.9	60.6	78.3	96.1	112.1	125.1	137.9
57-58	8.8	24.4	43.8	61.7	78.9	94.6	108.8	125.2	144.1
59-60	8.8	23.0	35.9	47.6	56.8	68.2	84.6	102.4	118.9
61-62	5.6	14.8	22.4	32.3	46.5	63.6	82.5	100.1	115.7
63-64	3.4	10.1	18.1	26.7	39.1	49.2	61.0	73.5	83.0
65-66	5.1	15.0	26.5	40.1	53.8	70.1	85.7	100.9	116.7
67-68	7.0	20.5	35.0	52.2	71.9	86.5	103.8	119.2	131.6
69-70	5.0	16.6	31.5	46.1	58.2	73.2	87.0	97.2	109.1
71-72	7.6	22.1	37.1	52.5	69.8	83.8	95.9	109.0	121.9
73-74	7.6	23.3	41.3	56.8	71.0	84.4	97.9	112.2	124.8
75-76	8.1	22.3	36.9	51.0	65.7	81.4	94.3	105.5	116.1
77-78	5.3	15.0	25.4	35.4	44.4	52.9	61.5	69.5	73.4
79-80	4.9	12.6	20.6	28.9	37.0	44.2	48.7	59.7	
81-82	3.0	7.2	12.6	19.3	23.4	29.8			45
83-84	1.9	7.3	10.4	12.2			30	100	113
85-86	2.3	5.8			39	62	69	78	85
			36	88	110	143	165	177	197
49-50	0	20	24	32	38	43	45	48	58
Years of follow-up	38	37	36	35	34	33	32	31	30

Year of first monitoring	Years of follow-up								
	20	21	22	23	24	25	26	27	28
49-50	428.6	450.8	467.7	484.8	501.5	524.3	553.0	568.8	586.9
51-52	344.3	353.5	367.6	382.9	400.0	417.5	422.3	431.9	432.8
53-54	317.3	335.1	347.3	362.7	362.8	375.9	395.1	414.4	422.1
55-56	306.2	316.2	326.6	336.1	346.1	357.3	370.3	375.6	387.9
57-58	323.2	332.3	346.4	364.7	380.7	387.1	399.2	408.4	430.4
59-60	263.4	278.0	288.0	293.8	292.9	296.2	300.6	296.0	309.2
61-62	242.5	250.7	259.2	265.8	279.7	287.6	329.2		
63-64	194.2	198.6	212.4	215.2	199.8			255	548
65-66	228.4	234.3	276.5			86	222	231	238
67-68	225.3			93	166	172	174	179	183
		26	94	98	100	101	103	106	111
67-68	83	88	90	92	96	98	99	103	106
65-66	55	56	59	61	64	67	74	76	79
63-64	46	49	50	50	53	55	57	62	67
61-62	132	139	152	154	161	171	178	187	195
59-60	229	241	249	264	277	288	296	313	326
57-58	248	252	258	262	269	283	303	315	333
55-56	207	207	213	225	240	247	260	281	303
53-54	163	172	176	185	200	216	227	246	262
51-52	431	459	482	508	529	560	578	612	654
49-50	110	114	117	120	123	129	133	142	145
Years of follow-up	19	18	17	16	15	14	13	12	11

TRIANGULAR PART) AND NUMBERS OF EMPLOYEES (LOWER TRIANGULAR PART) BY BY YEARS OF FOLLOW-UP TO 1986 FOR MALE SELLAFIELD RADIATION WORKERS EPISODE

Year of first monitoring	Years of follow-up									
	10	11	12	13	14	15	16	17	18	19
49-50	219.6	245.4	266.3	288.1	300.2	319.3	334.5	358.8	379.0	403.9
51-52	177.7	194.9	211.1	223.7	236.9	256.4	275.8	294.0	311.6	330.4
53-54	163.8	173.9	187.4	201.5	218.4	236.0	251.1	270.7	285.2	304.0
55-56	152.9	170.2	188.5	208.2	229.4	244.6	257.3	271.0	282.8	295.7
57-58	161.3	180.7	201.0	219.0	239.2	257.8	275.4	290.7	302.1	313.5
59-60	137.3	150.0	165.0	177.8	191.6	206.0	221.2	235.5	247.1	254.3
61-62	132.7	146.5	160.4	172.6	184.7	196.3	206.9	215.0	228.6	237.8
63-64	93.9	94.9	105.3	124.3	139.3	148.3	163.5	171.3	180.5	189.6
65-66	132.4	142.2	156.1	165.9	176.0	184.4	191.1	203.1	217.3	227.4
67-68	143.3	154.9	165.5	178.3	186.2	192.0	199.1	204.5	213.2	208.1
69-70	119.6	136.3	146.9	156.2	164.4	171.1	175.6	179.2	149.1	
71-72	135.0	144.9	153.5	158.8	165.9	171.7	182.4			26
73-74	135.6	147.5	157.0	162.4	146.8			22	52	54
75-76	126.7	131.3	160.1			6	40	42	45	45
77-78	76.1			55	97	102	108	114	118	123
57-58	127	69	143	154	166	176	184	188	201	221
55-56	127	136	146	149	153	165	172	178	187	194
53-54	92	98	102	110	122	126	142	148	156	159
51-52	217	232	249	271	297	321	350	364	383	409
49-50	60	66	72	75	79	81	89	94	99	106
Years of follow-up	29	28	27	26	25	24	23	22	21	20

Year of first monitoring	Years of follow-up									
	29	30	31	32	33	34	35	36	37	38
49-50	622.0	631.5	665.3	666.5	673.0	685.7	704.0	721.3	750.7	750.0
51-52	437.3	443.1	444.5	443.1	427.8	463.2	483.9	463.1		
53-54	425.8	440.5	446.9	462.1	466.9	472.3			495	1210
55-56	394.5	393.8	395.5	365.0			213	539	609	668
57-58	443.0	460.0			208	408	449	537	690	798
77-78	322	757	389	815	868	900	944	1011	1090	1191
75-76	562	581	599	607	643	720	817	935	1083	1248
73-74	246	254	265	282	311	340	371	399	466	549
71-72	186	197	207	220	234	247	277	318	368	438
69-70	126	135	154	158	174	195	214	232	282	343
67-68	108	110	119	139	151	157	176	213	242	294
65-66	83	88	96	105	112	125	143	180	223	299
63-64	73	76	81	89	98	105	134	173	208	259
61-62	210	223	238	256	303	379	443	537	660	842
59-60	337	361	403	465	534	618	717	851	1052	1189
57-58	365	414	467	505	559	627	737	804	893	995
55-56	329	353	380	404	441	478	514	586	700	768
53-54	280	290	301	314	337	375	416	496	635	731
51-52	687	719	756	799	876	1014	1164	1319	1478	1610
49-50	151	159	167	185	223	254	279	307	336	363
Years of follow-up	10	9	8	7	6	5	4	3	2	1

The distribution of average cumulative whole body annual recorded doses for these male Sellafield employees (all ages) is given in the table. The upper triangular part of the table gives the average cumulative dose by successive pairs of calendar years of first year of monitoring and for successive years of follow-up through to 1986. The lower triangular part of the table gives the respective numbers of workers.

Comparison of the average doses in the first year of follow up for these cohorts with those of figure 3 of [1], shows that the average dose patterns are similar when it is noted that a worker will not normally contribute a full year of dose during his first year of employment.

Examination of the pattern of average cumulative dose for each successive pairs of years of first monitoring suggests an initially constant annual rate of accumulation of dose, with this rate reducing in later years of follow up. This dose accumulation rate is higher in earlier cohorts. An examination of the data for those workers continuously employed through to 1985 (eg. 20 for the 1949-50 cohort, 94 for the 1969-70 cohort, etc) supports this notion of a genuine reduction in individual average annual dose with increasing length of follow up.

CONCLUSIONS

This preliminary analysis draws out some features of these data, but further work is needed to better understand these data, particularly with respect to age at exposure and occupation. These results are consistent with a reduction in annual external whole body doses received by Sellafield workers over the follow up period.

REFERENCES

1. Smith P G, Douglas A J (1986) Mortality of workers at the Sellafield plant of British Nuclear Fuels. British Medical Journal, Vol 293, 4 October, pgs 845-854.
2. National Radiological Protection Board (1991) First Analysis of the National Register for Radiation Workers. In press.
3. Gardner M J et al. (1990) Results of case-control study of leukaemia and lymphoma among young people near Sellafield nuclear plant in West Cumbria. British Medical Journal, Vol 300, 17 February, pgs 423-434.
4. Kinlen L J. A paper in preparation: a case-control study of the incidence of leukaemia and non-Hodgkin's lymphoma in young persons from Seascale.
5. Goldsmith R et al. (1989) Mortality and career radiation doses for workers at a commercial nuclear power plant: feasibility study. Health Physics, Vol 56, No 2, February, pgs 139-150.

DEVELOPEMENT OF TLD BADGE READERS FOR PERSONNEL MONITORING IN INDIA

S.Kannan, P.Ratna, M.S.Kulkarni, T.V.Venkateswaran & U.Madhvanath

Division of Radiological Protection
Bhabha Atomic Research Centre
Bombay (INDIA)

ABSTRACT

More than 20,000 radiation workers are monitored in India using TLD badges⁽¹⁾ containing three teflon CaSO₄:Dy discs fixed on an aluminium card. A microprocessor based semiautomatic version of the TLD reader has been developed to handle about 2000 cards per month. It is having features like automatic dark current cancellation, autoranging, user selectable calibration factor, printer interface, digital glow curve storage, RS-232 serial interface and a built-in LED light source for system stability check. The Reader covers a range of 0-10 Sv with a minimum measurable dose of 50 μ Sv for X and gamma radiation. The hardware and software details of the TLD Reader are discussed.

INTRODUCTION

Personnel monitoring of radiation workers in India is carried out using both film dosimeters and TLD. However, TLD is preferred to film dosimeters owing to the advantages such as amenability to automation and stability under extreme climatic conditions of high temperature and humidity existing in most parts of India. Personnel monitoring in India is carried out by regional centres and an elaborate quality assurance programme by the Division of Radiological Protection (DRP), Bhabha Atomic Research Centre (BARC) ensures compatibility between centres. A manual type TLD reader indigenously developed was found to be satisfactory for dose evaluation in small centres which handles upto about 1000 cards per month. A microprocessor controlled data logger is used to interface these readers, to an IBM PC/XT for data transfer, glow curve display and storage. This paper discusses the design considerations of a semiautomatic personnel monitoring system having features like built-in interface for a PC/XT, motorised mechanical arrangement to read the three dosimeters of the TLD badge⁽¹⁾ sequentially, a self test diagnostic software, storage of digital glow curve data with high or low resolution etc.

SYSTEM DESCRIPTION

The BARC TLD Badge⁽¹⁾ consists of three 0.8mm thick (13mm diameter teflon CaSO₄:Dy) discs fixed to an aluminium card. The card is positioned inside a plastic holder provided with appropriate energy compensation filters, for the three dosimeters. The semiautomatic TLD reader shown in fig.1 is based on a compact 8085 microprocessor system. It consists of a rack

and pinion arrangement coupled to a D.C motor for transporting the dosimeter card to the heating position, a reproducible temperature control circuit for heating TL dosimeter upto 280°C, a multiplier phototube (PMT) having a suitable spectral response (EMI 9924), a regulated EHT(500-1000V variable) for the PMT and a current to frequency (I-F) converter with an automatic dark current suppression circuit. The operation of the TLD Reader is controlled by a ROM based 8K byte assembly language program. Two 6V dc motors are used, the first one for moving the card to the reading position inside the reader and the second for raising and lowering the kanthal heater to make contact with the TL dosimeter. Microswitches are used for sensing proper positioning of the dosimeter over the heater. The TLD reader is provided with a key-board consisting of the numeric and function keys and an eight-digit, seven-segment LED display for displaying various display parameters and the readings. A separate digital panel meter is used for displaying temperature and the EHT. The TLD reader is provided with a centronic parallel printer interface for an on-line/off-line printout of data, and a serial RS-232 interface for connection to an IBM PC/XT. The detailed hardware and software of the reader can be obtained from the authors.

OPERATION CYCLE

The dosimeter card is manually removed from the plastic holder and fed into the reader. A "Start" key is pressed to start the reading cycle. A buzzer prompts the operator to enter the badge number(B.No.) i.e. the dosimeter identification number which is entered using the numeric and "Enter" keys on the front panel. Prior to this, the institution number (I.No.) assigned for a batch of badges from an institution and the location code (LC) to indicate the location on the body where the TLD badge is worn can be entered. A location code of 00 is used for chest, 01 for right wrist and 02 for left wrist. If these numbers are not entered, a code of "00" is taken as default value for the location code and the institution number remains unchanged. On entering the badge number, the dark current of the PMT is sampled and stored on a low leakage capacitor for automatic subtraction from the output during the reading cycle. The TLD card is then transported by a geared dc motor till the dosimeter one is positioned over the heater. A pulse width modulated drive is used for precise control of the dc motor. The reading cycle is started with energising the heater. A heater control circuit heats the dosimeter to 280°C in less than 10 seconds and maintains it till the end of the reading cycle. A typical temperature profile during the reading cycle is shown in fig 2. The anode current from the PMT is fed to an I-F converter. The output pulses from the I-F converter are fed to a microprocessor compatible 8 digit counter (8253). A 10 pps clock interrupt is used to update the display and to read and store the counter readings every second in a non-volatile RAM (random access memory) for obtaining integral glow curve data. At the end of the read-out cycle, the integral glow curve data is transmitted to the PC/XT. A BASIC program finds the difference between the successive readings to

obtain the differential data and displays the glow curve on the PC monitor. The data is also stored on a floppy/hard disk. In addition, at the end of every readout cycle, the dose and the other dosimeter details are stored in a non-volatile RAM which has a capacity for dose data storage of 100 badges and printed on a 24 column dot matrix printer. The dosimeters 2 & 3 are read similarly and the card is ejected out. When the memory is exhausted after readout of 100 badges, the system goes into a lockout mode with a message "FULL" on the display. This ensures that there is no loss of data due to non-availability of memory for storage. The TLD reader cannot be operated unless the memory is cleared by the operator using a code number and pressing the "Enter" key on the panel. The reading stored in the memory can be recalled by using a "RECALL" key and entering the badge number of interest.

RESULT

The TLD reader has a readout time of three minutes per badge⁽¹⁾. A typical glow curve recorded from a 0.8mm TL dosimeter exposed to 6.2 mSv as stored in PC/XT is shown in fig.2. A low resolution glow curve storage with 60 points per curve as shown in fig.2 would provide enough evidence of a correct read-out and genuineness of the dose and to reject an occasional spurious reading⁽²⁾. A software has been written in BASIC to retrieve and display any of the stored glow curves from the database. The dosimeter data stored in the non-volatile memory of the TLD reader is transmitted off-line to a PC/XT for dose evaluation, preparation of the dose reports and record keeping. The system covers a range of 50 μ Sv to 10 Sv for X & Γ radiations.

CONCLUSIONS

The system costs about \$12,000 with 500 badges and the commercial production is already underway. The system will be a low-cost option for any medium scale personnel monitoring centre. The built-in interface in the TLD reader makes it possible to connect two or more such readers to a single IBM PC/XT on time-sharing basis. To achieve a faster read-out time, a modified TLD badge with 0.4 mm CaSO₄:Dy teflon dosimeter and a non-contact hot nitrogen gas heating system are under development.

REFERENCES

1. Vohra K.G., Bhatt R.C., Bhuwan Chandra, Fradhan A.S., & Shastri S.S., 1980. A Personnel Dosimeter TLD Badge Based on CaSO₄:Dy Teflon TLD Discs. Health Physics, 38, pp. 193-197.
2. Barthe J.R., Bohm J., Christensen P., Driscoll C.M.H., Harvey J.R., Julius H.W. & Marshall M., 1987. Report on The Application of Thermoluminescence Dosimetry to Large Scale Individual Monitoring. Radiat. Prot. Dosim. 18(1), pp. 47-61



FIG. 1. SEMIAUTOMATIC TLD READER

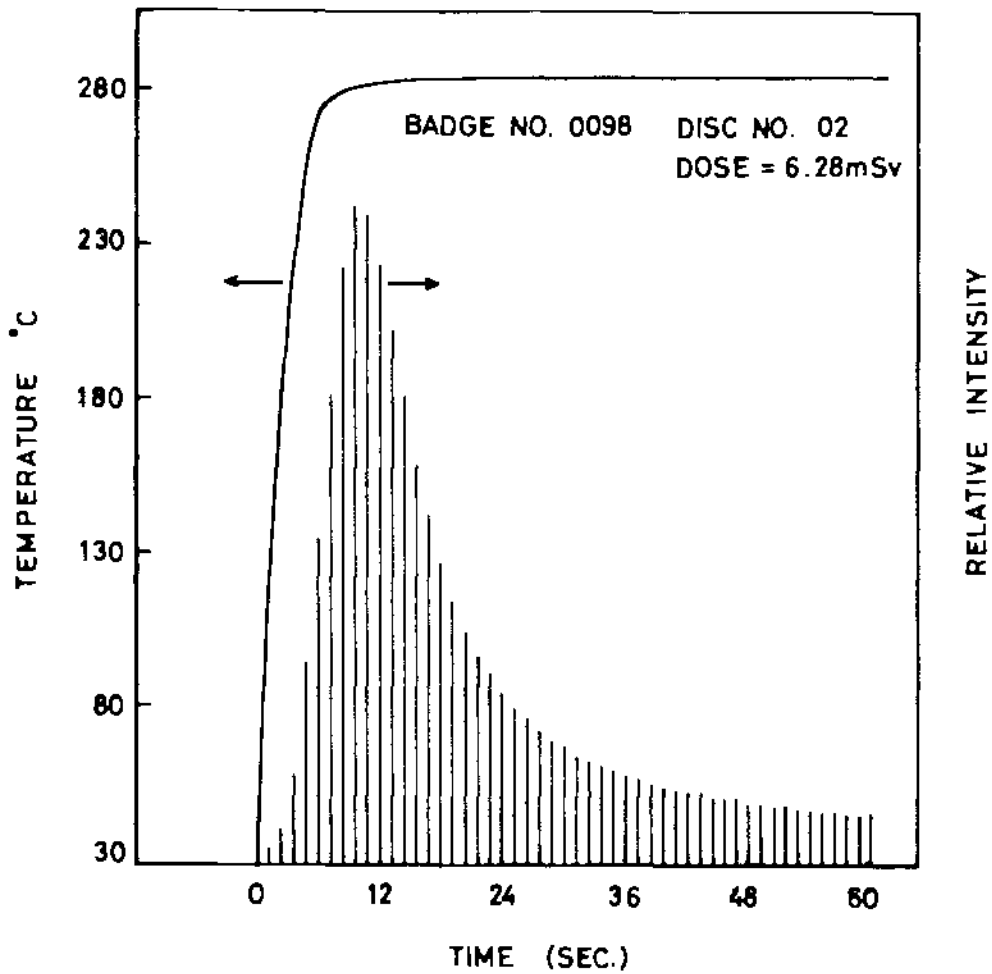

FIG.2. GLOW CURVE & TEMPERATURE PROFILE

NOUVELLE GESTION INFORMATIQUE
DU SUIVI DOSIMETRIQUE DE
L'EXPOSITION EXTERNE DES TRAVAILLEURS
APPLICATION DOSDAM

Y. MAGRI, M. CHERFI
CEA/DAM/B.III

NEW DATA PROCESSING MANAGEMENT
OF THE DOSIMETRY FOLLOW-UP OF THE
WORKERS EXTERNAL EXPOSURE
DOSDAM APPLICATION

ABSTRACT

The data processing application DOSDAM of the dosimetry follow-up of workers, is characterized by high variables of the treatment, in order to adapt to any evolution of the legislation, a centralised management, common to all the users scattered on the national territory, and above all by a data-processing transfert enabling each local responsible worker to perform specific treatment such as the management of workstations.

INTRODUCTION

Le Centre d'Etudes de Bruyères-le-Châtel a mis en exploitation depuis Janvier 1991 une application informatique appelée DOSDAM "Dosimétrie de la Direction des Applications Militaires", destinée à la gestion du suivi dosimétrique du personnel de la Direction des Applications Militaires du COMMISSARIAT A L'ENERGIE ATOMIQUE (CEA/DAM).

Une gestion commune de la dosimétrie pour tous les centres DAM, une adaptibilité complète à toute évolution de la législation et des techniques dosimétriques et surtout, un traitement spécifique local, comme le suivi des postes de travail, sont les principaux objectifs de cette application dont nous décrivons les principales caractéristiques.

PRINCIPES

L'application repose sur trois principes :

- la décentralisation de la saisie des données et l'édition des résultats dans chaque centre de travail réparti sur tout le territoire français,
- le paramétrage complet des données qui permet une flexibilité totale de l'application, c'est-à-dire son adaptabilité à toute évolution des techniques de dosimétrie ou de la législation, mais également aux caractéristiques particulières de chaque centre administratif,

- le transfert des données (identité agents, doses individuelles, etc...) extraites d'une base commune et transmises sous forme de fichiers informatiques directement exploitables sur micro-ordinateur par les logiciels habituels (dBase III +, Pascal, etc...).

Ainsi, la particularité essentielle de cette application est-elle d'offrir à chaque responsable local de radioprotection à la fois une gestion commune sur une base de données centralisée et à partir des fichiers transférés, une gestion spécifique locale comme le suivi des visiteurs, la détection des doses anormales et le suivi des postes de travail...

DESCRIPTION

L'application DOSDAM est implantée sur un ordinateur DPS7 du Centre d'Etudes de Bruyères-le-Châtel qui gère un réseau informatique entre tous les centres métropolitains de la DAM. Chaque utilisateur dispose comme terminal, d'un micro-ordinateur type IBM PC AT émulé en terminal DKU sur le réseau. Il assure ainsi le suivi administratif, la demande et l'attribution des dosimètres de tous les agents CEA et entreprises exerçant sur le (ou les) centre de travail dont il assume la radioprotection.

Les opérations comme la commande des dosimètres pour tous les centres auprès d'un même fournisseur et l'exploitation des résultats dosimétriques issus du même laboratoire de mesure sont à la charge du Service de Protection contre les Rayonnements du Centre d'Etudes de Bruyères-le-Châtel.

Ces opérations produisent des "états" sous forme de "fichier-spool" d'édition mis à la disposition de chaque responsable local qui décide d'une manière indépendante du moment et des conditions (type imprimante, nombre d'exemplaires...) de l'édition proprement dite.

Le suivi dosimétrique s'exerce sur tous les agents travaillant sur un (ou plusieurs) centre de travail qu'ils soient personnel CEA ou d'entreprises ou visiteur. Il repose, en premier lieu, sur un suivi administratif de chaque individu qui consiste à prendre en compte l'évolution de quelques données, regroupées sous le terme "position administrative" comprenant entre autres, le centre, le service, la classification radiologique associés à des dates de début et de fin de position. La dose individuelle d'une personne est ainsi affectée à sa véritable position administrative à la période de port du (ou des) dosimètre.

En particulier, lors des études de statistiques dosimétriques, la détermination des doses collectives par unité administrative prend en compte les différents mouvements de personnel entre service ou la variation des classifications radiologiques.

DOSDAM permet l'attribution, la commande de tous les types de dosimètres actuellement en service et, grâce à son paramétrage, de tous les futurs dosimètres susceptibles d'être employés. Ces dosimètres peuvent être attribués à toute personne quelle que soit sa classification radiologique suivant toute périodicité de port.

Chaque dosimètre est associé au centre de travail et à l'installation où il est porté par un individu. Ainsi, la dose mesurée peut être affectée à l'installation, voire au poste de travail de l'agent.

Il est possible, par là même, de dissocier par lieu de travail, les différentes doses prises par une même personne sur plusieurs postes de travail.

La diffusion des résultats dosimétriques s'effectue :

- pour chaque personne sous forme d'un "relevé individuel de dose" placé sous pli confidentiel,
- pour chaque unité administrative, sous forme de "situations dosimétriques" qui expriment pour tous les agents de l'unité concernée, la (ou les) dose individuelle mesurée lors de la dernière période de port les doses cumulées sur les trois derniers et les douze derniers mois glissants,
- pour chaque installation, sous forme de "résultats dosimétriques" qui indiquent les doses mesurées sur tous les dosimètres portés dans l'installation concernée au cours de la dernière période de port.

Les services médicaux du travail reçoivent pour leur part, les situations dosimétriques de tous les agents dont ils assurent le suivi médical et les résultats de tous les dosimètres portés sur le centre de travail concerné.

Des statistiques dosimétriques présentées aux organismes de sûreté sont calculées, soit par unité administrative ou par installation en prenant en compte l'évolution de la position administrative de chaque agent et en dissociant les doses calculées par poste de travail.

ORIGINALITE DE L'APPLICATION

Chaque responsable local peut extraire de la base commune centralisée des données relatives aux individus, aux doses et les transférer sur son micro-ordinateur sous forme de fichiers. Il lui est alors possible de mettre en oeuvre des traitements informatiques qui lui sont spécifiques, ou qui mettent en jeu d'autres paramètres particuliers du centre de travail non gérés dans l'application, ou enfin, d'autres traitements non réalisables sur réseau comme les traitements graphiques, le publipostage etc...

En particulier, cette méthode permet de réaliser un traitement immédiat des résultats dosimétriques pour mettre en évidence, dans les plus brefs délais, toute dose anormalement élevée, d'éditer des statistiques particulières (sur des critères très détaillés).

L'utilisation principale de ce mode d'exploitation est le suivi du poste de travail de chaque agent, suivi qui ne pourrait être réalisé sur une application centralisée en raison de la grande mobilité des personnes et l'extrême diversité des postes gérés, mais que permet le transfert des données par voie informatique jusqu'au responsable direct de la radioprotection de l'installation.

APPLICATIONS DES RECOMMANDATIONS DE LA CIPR. UTILISATION DES
CONTRAINTES ET DES NIVEAUX DANS DES CAS CONCRETS

Pr. H. JAMMET

Vice-Président de la Commission Internationale
de Protection Radiologique
Mme A. SUGIER, Directeur Délégué à la Protection
Institut de Protection et de Sécurité Nucléaire

INTRODUCTION

La Commission Internationale de Protection Radiologique dans sa Publication 26 présentait sous le terme de normes (standards) d'une part des limites, d'autre part des niveaux. Dans la pratique la notion de borne supérieure (upper bound) est apparue progressivement dans les processus d'optimisation. Dans la CIPR 60 les normes comprennent des limites, des contraintes et des niveaux.

Les limites recommandées par la CIPR 60 concernent des doses individuelles liées aux personnes (travailleurs ou membres du public) et sont d'application générale. Les contraintes introduites par la CIPR 60 sont liées aux sources, s'expriment en doses ou en risques et sont d'application particulière. Les niveaux continuent d'être conçus comme des guides de référence permettant avec la flexibilité appropriée de traiter des problèmes relatifs aux sources, aux environnements professionnel ou public et aux personnes concernées.

L'expérience en protection radiologique montre que les limites ne sont que d'une utilité très réduite du fait qu'elles constituent la barrière au-dessus de laquelle on entre dans la zone des expositions interdites. Par contre l'avenir est pour une bonne pratique de la protection de recourir à un usage rationnel des contraintes pour l'application du principe essentiel d'optimisation et des niveaux pour guider les actions entreprises dans les cas où une souplesse s'avère nécessaire.

CONTRAINTES GÉNÉRALITÉS

Dans le domaine relatif aux pratiques qui sont maîtrisables le principe d'optimisation de la protection constitue le fondement essentiel. La possibilité d'encadrer les solutions optimales par un système de contraintes judicieusement établies est souhaitable. Ceci peut concerner des situations normales avec des expositions habituelles ou des situations accidentelles éventuelles avec des expositions potentielles. Aux premières correspondent des contraintes de dose, aux secondes des contraintes de risque.

L'établissement de valeurs appropriées pour les contraintes relève d'une méthodologie multidimensionnelle. Celle-ci doit tenir compte de considérations sanitaires, techniques, économiques et sociales. Deux approches sont possibles ; l'une par voie d'optimisation, l'autre par voie statistique. Lorsque l'on procède à l'inventaire des solutions de protection on aboutit à une gamme de valeurs dont l'enveloppe supérieure tend vers la contrainte correspondante. De même lorsque l'on analyse les résultats statistiques des expositions liées à une opération, l'ensemble obtenu peut être cerné par une enveloppe supérieure qui peut correspondre à la contrainte correspondante.

La fixation des contraintes de dose ou de risque relève de responsabilités différentes selon qu'elles s'appliquent de façon plus générale ou plus particulière. Schématiquement on peut admettre que c'est aux autorités compétentes de fixer les contraintes relatives à des catégories de sources. Par contre les contraintes concernant une seule source où des installations même complexes sont spécifiques et peuvent dans beaucoup de cas relever du management. Cette répartition des rôles respectifs des managements et des autorités devrait responsabiliser les premiers en leur permettant de proposer les contraintes relatives à leurs installations et confirmer le contrôle exercé par les autorités.

Les modes d'expression des contraintes varient selon leur application, bien qu'elles soient toujours liées aux sources. Dans certains cas d'exposition il s'agit de contraintes de dose et s'expriment en Sv. Dans d'autres cas de pollution radioactive il s'agit de contrainte d'activité et elles sont données en Bq. Enfin pour les expositions potentielles liées à d'éventuels accidents, elles ne peuvent concerner que des risques et s'exprimer généralement en termes de détriment.

Dans la pratique de la radioprotection, les limites pour les travailleurs et le public sont très générales et peu nombreuses. Par contre les contraintes sont nécessairement nombreuses et variées adaptées aux cas particuliers liés aux différentes sources. Certaines peuvent être plus rigides portant sur une exposition annuelle, d'autres plus souples portant sur des périodes plus longues (5 ans par exemple), d'autres enfin plus adaptées à des circonstances, liées par exemple aux conditions météorologiques ou hydrographiques.

EXEMPLES

Pour mieux comprendre l'intérêt et l'application du concept de contrainte il convient de donner un certain nombre d'exemples à titre purement indicatif. Trois domaines méritent d'être abordés : l'exposition professionnelle, l'exposition du public, l'exposition potentielle.

EXPOSITION PROFESSIONNELLE

Un exemple caractéristique d'exposition professionnelle peut être fourni par l'utilisation des rayonnements en radiologie médicale : radiodiagnostic, radiothérapie et médecine nucléaire. Rappelons que les limites de dose individuelles d'après la CIPR 60

sont de 100 mSv/5 ans et 50 mSv/1 an. Pour le radiodiagnostic on peut choisir deux cas. Le premier concerne les examens radiologiques banaux tels que les radiographies pulmonaires, osseuses, rénales, etc... ; les installations sont telles qu'une contrainte de dose individuelle de 10 mSv an⁻¹ paraît convenable. Le deuxième est relatif à la radiologie d'intervention per-opératoire ; les conditions de travail sont particulièrement délicates et une contrainte de 20 à 50 mSv an⁻¹ paraît adaptée sur une période de 5 ans. Pour la radiothérapie on peut également envisager deux exemples. En radiothérapie externe par source de Co60 ou par accélérateur, les installations permettent d'éviter pratiquement toute exposition du personnel ; une contrainte de 5 mSv an⁻¹ paraît convenable. En radiothérapie par source scellée introduite dans l'organisme, les conditions sont nettement moins favorables et une contrainte de 10 à 20 mSv an⁻¹ semble adaptée.

Pour la médecine nucléaire il convient de distinguer entre les applications diagnostiques et les utilisations thérapeutiques. Dans le premier cas, compte tenu de la nature et de l'activité des substances radioactives utilisées une contrainte de 5 mSv an⁻¹ ne devrait pas poser problème. Dans le deuxième cas, du fait des activités importantes nécessaires au traitement, des contraintes comprises entre 10 et 20 mSv an⁻¹ paraissent raisonnables.

EXPOSITION GÉNÉRALE DU PUBLIC

Il semble qu'un bon exemple d'exposition générale du public soit celui des rejets radioactifs à partir d'installations diverses. Rappelons que les limites de dose individuelle pour les membres du public recommandées dans la CIPR 60 sont de 1 mSv an⁻¹, avec dans des circonstances particulières 5 mSv/5ans.

Les rejets atmosphériques des réacteurs nucléaires fournissent un exemple intéressant de contraintes relativement strictes : dans le cas d'une centrale comportant 2 réacteurs (PWR) de 1300 MWe, le rejet autorisé annuellement est de 1650 TBq pour les gaz rares et 55 GBq pour les halogènes et aérosols, correspondant à une exposition du groupe critique de l'ordre de 20 µSv an⁻¹.

Les rejets radioactifs en milieu aquatique sont très divers selon qu'il s'agit de grosses installations de retraitement de combustible, de réacteurs nucléaires et d'utilisations de sources non scellées en médecine nucléaire. Les installations de retraitement impliquent des rejets importants et de ce fait sont implantées sur de très grands fleuves ou en bord de mer dans des sites favorables. Dans le cas de l'usine de retraitement de la Hague une contrainte de 1700 TBq a été fixée pour le rejet annuel du mélange de radionucléides émetteurs βγ (hors tritium), qui contribue de façon majoritaire à l'exposition : celle-ci est de l'ordre de 15 µSv an⁻¹. Les réacteurs nucléaires ont des rejets radioactifs liquides beaucoup plus faibles, mais sont implantés sur des fleuves plus petits et à débit souvent irrégulier ; il en résulte que la contrainte annuelle de 1,1 TBq an⁻¹ (dans le cas de la même centrale ayant 2 réacteurs PWR de 1300 MWe pour le

mélange des radionucléides émetteurs $\beta\gamma$, hors tritium paraît satisfaisante, avec toutefois une préférence pour l'expression de cette contrainte sur une période de 5 ans. L'utilisation des sources non scellées en médecine nucléaire devrait pouvoir se faire sans pratiquement de rejets radioactifs et par suite des contraintes très sévères devraient pouvoir être imposées.

EXPOSITION POTENTIELLE LIEE A UN ACCIDENT EVENTUEL

On entre ici dans un domaine difficile car les conditions varient considérablement entre les domaines nucléaire et radiologique. La sûreté nucléaire a fait l'objet d'études approfondies et est gérée de façon rigoureuse. On ne peut malheureusement pas en dire autant de la sûreté radiologique concernant les utilisations des rayonnements dans l'industrie, la recherche ou la médecine. Par ailleurs, l'expérience et les statistiques montrent que la fréquence des accidents dans le domaine radiologique est grande alors que les conséquences sont relativement réduites à quelques victimes, bien que dans certains cas un grand nombre de personnes aient pu être atteintes (Goïana). Dans le domaine nucléaire par contre une gamme très étendue de scénarios est possible allant de dysfonctionnements mineurs à des accidents majeurs (Tchernobyl) mais dont la fréquence est extrêmement faible. Il résulte de toute cette complexité que la fixation de contraintes de risque pour les expositions potentielles est particulièrement délicate. Elle apparaît comme raisonnablement valable pour les installations radiologiques et pourrait être envisagée dans une fourchette de 10^{-4} à 10^{-5} .

Par contre pour les accidents nucléaires majeurs à très faible probabilité d'occurrence et à conséquences considérables, il apparaît encore actuellement difficile de rationaliser le choix de valeurs appropriées pour des contraintes de risque.

NIVEAUX GENERALITES

D'une façon très générale la CIPR 60 propose des recommandations plus strictes concernant les limites de dose individuelle et introduit la notion de contrainte comme borne supérieure des processus d'optimisation. Mais elle insiste aussi sur la nécessité d'une souplesse efficace dans la pratique courante de la protection radiologique. Cette souplesse ne doit pas être comprise dans le sens d'un certain laxisme mais au contraire comme traduisant une plus grande rigueur dans la prise en compte des paramètres en jeu. Il faut reconnaître en outre que la CIPR apporte une clarification essentielle entre les situations où le contrôle des pratiques est possible et les situations de facto où seule l'intervention peut apporter une réduction des expositions. Dans le premier cas on peut appliquer le principe de limitation au moyen de limites, de contraintes ou de niveaux. Dans le dernier cas ni les limites, ni les contraintes ne peuvent et ne doivent être utilisées, seuls les niveaux doivent être appliqués. Mais les principes de justification et d'optimisation restent valables pour mener à bien la protection radiologique.

Les niveaux sont des guides qui ne présentent pas la rigidité des limites, ni le respect des contraintes, mais au contraire permettent dans un grand nombre de cas une souplesse indispensable à une protection rationnelle. Souvent les niveaux envisagés apparaissent comme des gammes bornées par des valeurs inférieures et supérieures, afin de faciliter leur prise en considération pour l'aide à la décision. La méthodologie qui préside à l'établissement des niveaux est, comme pour les contraintes, multidimensionnelle. Les paramètres sanitaires, techniques, économiques et sociaux doivent être impliqués dans une fixation rationnelle. Par ailleurs, il peut être utile de tester la validité des choix ainsi faits, par des comparaisons avec les données statistiques de l'irradiation naturelle notamment. En pratique une très grande variété de niveaux peut être utilisée, dont nous retiendrons ici trois types essentiels relatifs à l'application de la réglementation, aux investigations et aux interventions en protection radiologique.

EXEMPLES

Pour illustrer les généralités précédentes nous choisirons des exemples dans les domaines de l'application, de l'investigation et de l'intervention. Le premier est relatif à l'application ou non du système de protection. Le second concerne les études à mener ou les surveillances à exercer pour déceler les sphères d'intérêt pour la protection. Le troisième se rapporte aux actions à entreprendre pour faire face à des situations où l'on souhaite réduire les expositions existantes ou engagées.

APPLICATION

Il s'agit de l'application du système de protection. Ainsi un excellent exemple de niveau d'application général est fourni par les valeurs recommandées du Codex Alimentarius (Organisation Mondiale de la Santé et Organisation pour l'Alimentation et l'Agriculture) concernant la libre commercialisation des denrées alimentaires contaminées après un accident. Des niveaux d'application particuliers portent sur les activités au-dessous desquelles on n'est pas tenu de faire une déclaration ainsi que celles au-dessous desquelles on n'est pas tenu de demander une autorisation préalable.

INVESTIGATION

L'investigation consiste à fixer les niveaux au-dessus desquels les résultats sont tels qu'une attention doit être portée aux problèmes posés à la protection radiologique. Un exemple intéressant est fourni par l'irradiation naturelle. La CIPR 60 demande que l'on prenne en compte dans certains cas l'irradiation naturelle des membres du public ou des travailleurs au cours de leur travail. Des niveaux d'investigation sont à établir au-dessus desquels on considère si l'on doit ou non envisager des mesures de

protection. Ainsi pour les maisons existantes un niveau d'investigation de 200 Bq/m³ en Rn est le point de départ des études statistiques à effectuer. Pour les locaux de travail, notamment dans les mines en général, des niveaux d'investigation devront être fixés afin de sélectionner les conditions de travail qui peuvent poser problème.

INTERVENTION

Le domaine par excellence des niveaux d'intervention concerne les accidents radiologiques ou nucléaires. En général, vu la variété des scénarios possibles, des niveaux sont fixés, dans une gamme assez large de valeurs comprises entre un niveau inférieur au-dessous duquel l'intervention est improbable et un niveau supérieur au-dessus duquel elle est presque certaine. De tels couples de niveaux doivent être établis pour les différentes interventions envisagées : confinement, évacuation, interdiction de consommation alimentaire. De même des niveaux peuvent être fixés pour limiter l'exposition des membres des équipes de secours intervenant en cas d'accident radiologique ou nucléaire.

CONCLUSION

Les généralités et les exemples précédents sont relatifs aux contraintes de dose, d'activité et de risque, ainsi qu'aux niveaux d'application, d'investigation et d'intervention. Ils montrent la voie à la fois souple et efficace offerte par les nouvelles recommandations de la CIPR 60.

Les limites de dose individuelle ne sont que d'un intérêt réduit pour une bonne protection radiologique, vu leur très grande généralité. Par contre, les contraintes apparaissent comme des moyens parfaitement adaptés à la grande variété des sources de rayonnements. De même les niveaux peuvent en tant que guides souples canaliser les décisions vers les solutions les meilleures.

Ce sont certainement deux modalités de normes de protection radiologique qui présentent pour l'avenir le plus grand intérêt.

LES TRAVAILLEURS DU GROUPE C.E.A. : SUIVI
RADIOLOGIQUE ET ANALYSES STATISTIQUES.

D. ROBEAU, M. TIRMARCHE, A. RAPHALEN

C.E.A./INSTITUT DE PROTECTION ET DE SURETE NUCLEAIRE
CENTRE D'ETUDES DE FONTENAY AUX ROSES
F92265 FONTENAY AUX ROSES CEDEX

C.E.A. WORKERS: RADIOLOGICAL AND STATISTICAL STUDIES

The radiological survey of the CEA workers is briefly explained. A preliminary study on the characteristics, the dosimetry and the mortality is presented on a subgroup of 17337 workers. The results of this study indicate the poor impact of the neutronic irradiation, the distribution of doses in function of the worker's attendance. The mortality is compared between three groups. A first group of workers having cumulated a dose less than 10 mSv, a second group having cumulated a dose between 10 and 50 mSv, and a third group having cumulated a dose greater than 50 mSv.

1. INTRODUCTION

L'exposition aux rayonnements ionisants des travailleurs du CEA est mesurée grâce au port d'un dosimètre individuel comptabilisant les différentes composantes de l'irradiation externe β , X, γ , neutrons thermiques et rapides. Jusqu'en 1984, l'attribution de ce film fut mensuelle pour tous les agents du CEA, depuis cette date le port du dosimètre mensuel est limité aux travailleurs susceptibles d'être exposés aux rayonnements ionisants, les autres agents (ceux exerçant essentiellement des fonctions administratives) ont une surveillance dosimétrique trimestrielle. Pour les agents exposés aux neutrons, la dose liée due aux neutrons épithermiques est mesurée depuis plusieurs années. L'irradiation liée aux émetteurs α est déterminée chez les mineurs d'uranium grâce à des dosimètres individuels, mesurant depuis 1982 l'énergie α potentielle des descendants du radon. Durant la période antérieure, cette exposition a été calculée à partir de nombreuses mesures d'ambiance radon effectuées dans les mines, en tenant compte du facteur d'équilibre entre le radon et ses descendants.

Certains travailleurs du CEA ont pu être soumis, selon les postes occupés, à une surveillance systématique d'une éventuelle contamination interne. Des mesures par anthropogamamétrie et à partir de l'analyse des urines de 24 heures permettent de déterminer l'existence d'une contamination par les radionucléides qu'ils manipulent. Ces mesures sont effectuées à des intervalles réguliers. La surveillance de la contamination interne est organisée par le médecin du travail qui en gère les résultats. Après chaque incident, le même processus de contrôle de la contamination

interne est déclenché. C'est donc le dossier médical de chaque agent qui contient les résultats des contaminations internes. L'irradiation externe annuelle de chaque agent du CEA est stockée sur des supports magnétiques depuis 1953. La connaissance de l'exposition totale d'un travailleur est un facteur important du suivi sanitaire et constitue un élément indispensable des études épidémiologiques. D'autre part, un accès à ces informations est nécessaire, si l'administration ou l'intéressé en font la demande.

2. PREMIERE ETUDE STATISTIQUE

2.1. But de l'étude.

Le but de l'étude est la description de l'ensemble du personnel CEA vis à vis de critères généraux, tels le cumul des doses reçues, l'âge, la mortalité.

2.2. L'état de la base de données exploitée.

Les sources d'information pour cette première étude statistique ont concerné 17337 agents CEA, soit 20% du personnel ayant travaillé au CEA depuis sa création. Ce sont les agents ayant reçu une dose cumulée non nulle au cours de leur carrière professionnelle. Pour ces agents, on a disposé de l'ensemble des données dosimétriques et administratives disponibles entre 1967 et 1985.

2.3 Résultats de l'étude.

Cette première étude a permis de définir les caractéristiques dosimétriques de la population CEA, et de définir les études qu'il est nécessaire d'entreprendre ultérieurement. Les caractéristiques suivantes ont été relevées.

2.3.1 Une population essentiellement masculine.

La population CEA ayant subi une irradiation non nulle est essentiellement masculine ; les études ultérieures ne pourront porter que sur une population masculine.

2.3.2 Pas de différence radiologique entre actifs et retraités.

Les études de dépendance n'ont pas montré d'hétérogénéité dosimétrique entre les différents groupes étudiés, c'est à dire les agents actifs, les agents retraités et les agents décédés avant leur départ du CEA. La seule dépendance notée l'a été par rapport au site d'affectation de l'agent.

2.3.3 Absence de mobilité des agents au cours de leur carrière.

85% des agents pris en compte n'ont pas changé d'établissement, c'est à dire de lieu de travail, au cours de leur carrière professionnelle.

2.3.4 Répartition des doses cumulées.

La dispersion des doses a été étudiée selon deux critères : le temps de présence au C.E.A., la nature des irradiations. Les

résultats de cette analyse sont schématisés par le diagramme en barres tridimensionnel ci-dessous. Ce diagramme indique le pourcentage des doses cumulées par les travailleurs :

- en utilisant quatre classes de valeurs de dose (0 à 20 mSv, 20 à 40 mSv, 40 à 60 mSv, plus de 60 mSv).
- en fonction du temps de présence des agents au C.E.A.
- en fonction du type de rayonnement ionisant.

2.3.4.1. Le temps de présence.

Dans cette première étude, on a simplement pris deux classes : les agents ayant moins de 10 ans de présence au C.E.A. et ceux ayant plus de 10 ans de présence au C.E.A. L'observation du diagramme en barres montre que la distribution des doses est indépendante de cette différenciation.

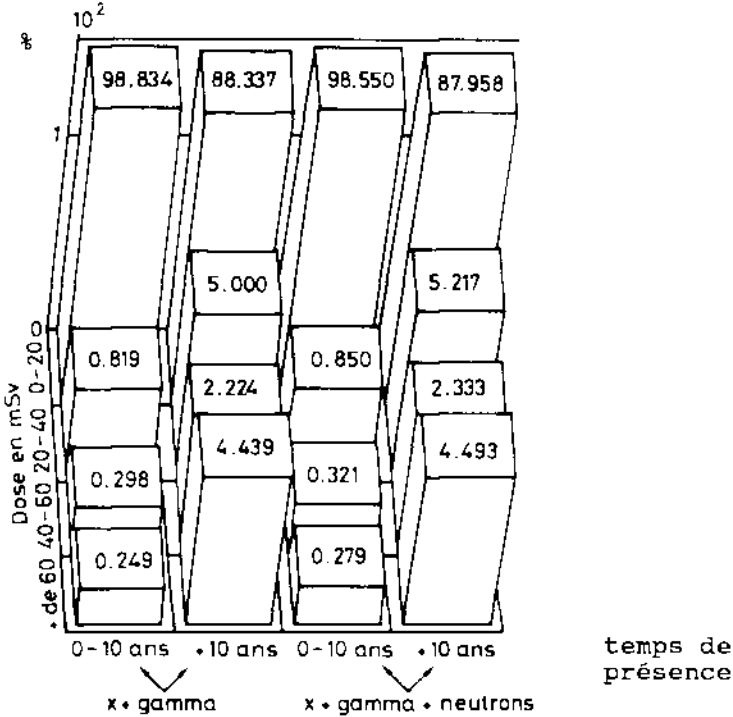

2.3.4.2. La nature des rayonnements.

Dans cette étude où on a pris en compte les irradiations X, γ et neutronique, on a choisi d'étudier l'impact des neutrons, en étudiant la dispersion des doses X+ γ +neutron comparée à celle des doses X+ γ . L'impact des doses neutron est très faible car associé à un effectif limité.

2.3.5. Etude de la mortalité.

Cette étude n'est en aucun cas une étude épidémiologique, mais une observation statistique. L'étude de la mortalité des travailleurs du C.E.A. n'a été effectuée que sur la tranche d'âge 25 à 60 ans. En effet lors de la réalisation de l'étude, il n'a pas été possible de faire le bilan des décès dans la population des retraités et en conséquence il n'a pas été possible de comparer les résultats de la mortalité des agents du C.E.A. avec la mortalité nationale. Par contre la mortalité a été étudiée en fonction des tranches d'âge et des doses reçues. On a donc comparé trois groupes d'agents, ceux ayant reçu une dose cumulée inférieure à 10 mSv, ceux ayant reçu une dose cumulée comprise entre 10 et 50 mSv et ceux ayant reçu une dose cumulée supérieure à 50 mSv. On ne note pas de différence significative entre les trois groupes de 25 à 40 ans. Le pourcentage de décès est plus élevé dans le groupe des doses supérieures à 50 mSv pour les agents âgés de 40 à 55 ans. Le pourcentage de décès augmente ensuite de façon significative après 55 ans pour les trois groupes étudiés. On note cependant une plus forte mortalité du groupe des doses 10-50 mSv. Cependant, la différence de mortalité ne peut pas être associée aux doses reçues car bien d'autres critères devraient être alors pris en compte (notamment les causes de décès).

BIBLIOGRAPHIE

- [1] D. ROBEAU, S. OUILLON, M. TIRMARCHE
Surveillance dosimétrique des travailleurs du CEA-1988-: projet de constitution d'un fichier reprenant l'irradiation externe cumulée de chacun des agents du groupe C.E.A.- Note SEAPS 88/02.
- [2] D. ROBEAU et coll.
Manuel d'utilisation de l'application DTC -Dosimétrie des travailleurs CEA- 1991 - Note CISI TRANSTEC Avril 1991.
- [3] D.ROBEAU et coll.
Manuel d'exploitation de l'application DTC -Dosimétrie des travailleurs CEA-1991- Note CISI TRANSTEC Avril 1991.
- [4] CISI-TRANSTEC: PROJET DTC Dossier d'analyse fonctionnelle-Mai 1990.
- [5] V. LEMER- Etude de la dosimétrie du personnel du C.E.A. de 1967 à 1985. Institut de statistique de Paris (Rapport de stage)-Juillet 1989.

**Radiological protection in medicine -
current and prospective
work of the ICRP**

J. Liniecki
Chairman, ICRP Committee 3
Medical University of Lodz, Poland

Abstract

Current and planned activity of ICRP in the field of radiological protection in medicine includes work on recommendations aimed at: optimized reduction of diagnostic X ray doses to patients, reduction of probability of potential exposure in medicine, protection of humans in biomedical research, and updating dosimetric information related to radiopharmaceuticals.

The paper provides background information for selection of these subjects and approximate time scheme for completion of the respective recommendations.

Introduction

The ICRP had been called to life in 1928 in Stockholm, by the Second International Congress of Radiology. This organisation has had always a medical character, even if prominent physicists and engineers played a determining role in the progress of radiological technology, health physics and radiation protection.

After World war II, the scope of ICRP activity has enlarged by including problems related to the protection in the nuclear field. However, special relationships with the International Society of Radiology still exists. This relationships is based not only on tradition. It reflects basic observations that population of medical workers exposed to ionizing radiations is very large and that exposure of the public to man-made radiation is dominated by the component resulting from radiological diagnostic activity. In the developed countries all other components, taken together, are lower at least by an order of magnitude compared with ab. = 1 mSv E per annum from the medical sources [U2].

It would, perhaps, be reasonable at this stage to analyse briefly what exposure of the public to the effective dose of this order could mean in terms of biological effects. For brevity let's consider possible magnitude of the expected extra cancer mortality. If one takes the ICRP nominal cancer mortality coefficient as reflection of reality, then at face value, the number of possible cancer deaths resulting from repeated - year after year - mean population exposure (Poland) to = 0.8 mSv per annum (Table 1) may approach 2 % of the actual cancer mortality rate. In absolute numbers this could be ab. 1500 cases per year in a country of ≈ 38 mln people.

Table I.

Possible cancer mortality rate resulting from exposure
of the public to diagnostic X-rays
(Poland, Staniszevska, 1986 [S1]).

Annual mean per caput effective dose:
0.8 mSv
Nominal cancer mortality coefficient (ICRP):
 $5 \cdot 10^{-2} \text{ Sv}^{-1}$
Possible induced cancer mortality rate per year:
 $\approx 40 \cdot 10^{-6} \text{ a}^{-1}$
Actual over-all cancer mortality rate [Z1]:
 $1800 - 1900 \cdot 10^{-6} \text{ a}^{-1}$

The view is sometimes expressed that such an estimate could be biased by neglecting following factors:

1. Difference between age distribution of patients and that of general population for which the risk coefficients have been specified. When comparisons were made, however (Staniszewska) [S1], of the above estimate with that, calculated using: 1/ real age and sex distribution of patients undergoing radiologic examinations in Poland; 2/ size of respective age and sex groups; 3/ age- and sex-specific cancer mortality coefficients for radiation-induced tumours proposed by BEIR V [N1], the difference between the latter estimate and the simple over-all assessment did not exceed + 20 % . This factor does not appear, therefore, to essentially modify the order of risk estimate.

2. The fact that a fraction of radiological examinations is performed in terminally ill patients in whom the risk cannot be expressed [R1]. There are very few credible estimates of the size of this fraction. In some parts of the U.K. the value did not exceed 5 % [R1] and there is no real indication that X-ray doses in the terminally ill are substantially higher than those in the rest of the population.

Therefore, total correction of the primary overall risk estimate appears negligible. Of course, an avoidable fraction of the collective dose (and therefore of the risk) is substantially lower. For instance, detailed considerations and estimates in the U.K. [N2] led the authors to conclude that the fraction amounts to ab. \approx 45 % of the total collective dose from medical sources (7500 out of 17000 manSv per year). In those countries in which the contribution from medical sources to the collective man made dose is higher than in the U.K. (\approx 0.4 mSva⁻¹) the avoidable fraction could also be greater.

In any case, the estimated order of extra risk due to diagnostic medical irradiation, even if on all accounts the health benefits by far exceed the concomitant risks justifies, in opinion of the Commission, radical efforts to reduce unnecessary exposure. This is especially true because this can be done without any sacrifice of the diagnostic benefit (image quality).

With respect to this basic opinion there is no essential difference between Publication 60 [I2] and Publ. 26 [I1] (Recommendations of 1977). However, Publ.26 directed the postulate primarily to medical practitioners (mostly radiologists and nuclear medicine physicians). Accordingly, the series of following recommendations (ICRP, Publ.34, 44, 52, 53, 57) [I3 - I7] had been addressed mainly - if not exclusively - to physicians of these professions, to hospital managements and health physicists.

The Commission took a somewhat different view in Publ. 60 [I2] (para 180). The text reads: "....." As a result, there is considerable scope for dose reductions in diagnostic radiology. Simple, low cost, measures are available for reducing doses without loss of diagnostic information, but the extent to which these measures are used varies widely. Doses from similar investigations cover ranges of as much as two orders of magnitude. Consideration should be given to the use of dose constraints, or investigation levels, selected by the appropriate professional or regulatory agency, for application in some common diagnostic procedures. They should be applied with flexibility to allow higher doses where indicated by sound clinical judgement."

This change in approach results from the conviction that appeals addressed to individual radiologists had not been sufficiently effective (at least on a large scale). This has been borne out by a fundamental, regular observation that frequency distribution of doses (entrance skin kerma or exposure) for a given diagnostic procedure, within a country or region, displayed a typical shape, exemplified in fig. 1 [U1]. When such distributions had been corrected [L1] for variation in patients body size, a variation in dose was less pronounced but that which persisted spanned still an order of magnitude.

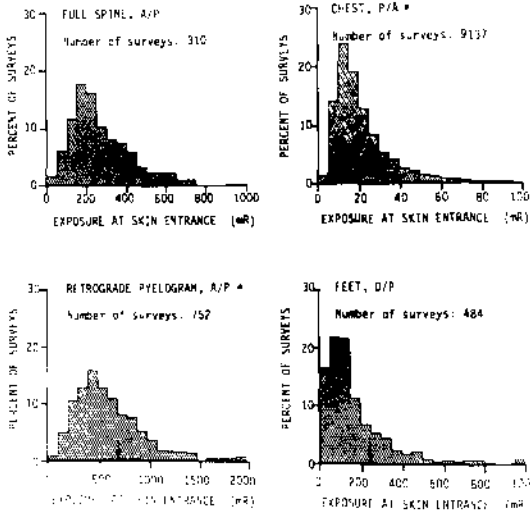

Fig.1. Frequency distribution of exposure at skin entrance for selected examinations in the USA (mR); arrow refers to mean exposure value (from [U1]).

This has been a regular finding in numerous surveys and, of course, such wide distributions cannot be accepted as justified, and much more so, as being consistent with requirement of the optimisation of protection. If optimal value of the dose lies somewhere in the shaded brackets (fig.2), the values above may be taken as excessive, and below as most likely insufficient for obtaining a good image. In other words, current situation results from a common lack of a functioning protection system, securing the feedback: magnitude of the dose → correcting action.

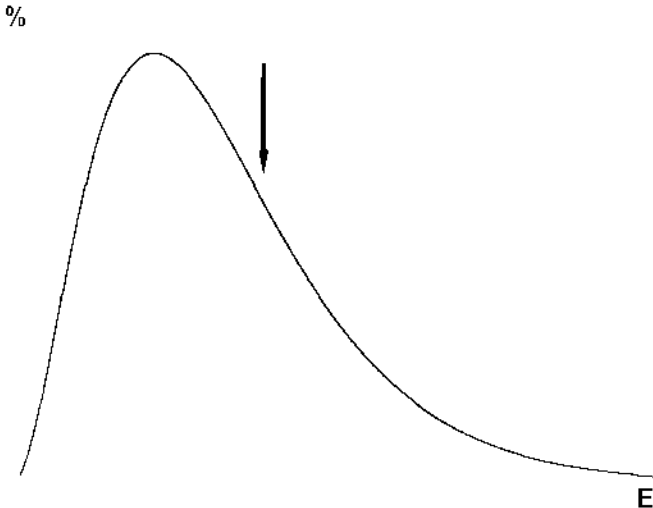

Fig.2. Idealised distribution of effective dose per examination
 --- Upper constraint - 75 percentile (?)
 ... Lower constraint - a dose too low for a satisfactory image.
 Arrow - mean dose.

Therefore, the Commission believes that constraints, or investigation levels, applied to diagnostic procedures have become necessary.

A. Task Group on Optimisation of Protection in Diagnostic Radiology

To look carefully into the subject and the experience gained so far in some countries and communities (USA, countries of the EEC) the Commission has made a decision to call into life in a short time, perhaps in 1992, a Main Commission - Task Group on "Image, Dose and Optimisation in Medical Radiology".

This group will collaborate closely with Committee 3. The principle objectives of this action would be:

1. To collect and analyse the experience obtained so far in those countries where such action has been already started on a wide scale, assessing and assuring image quality, combined with dose assessment in selected radiological procedures.

2. To work out and recommend measurement - and analytical procedures for dose-frequency distribution studies and to postulate criteria upon which ranges for exposure could be defined that may be accepted as justified at the current state of practice. (Below and above these some intervention would be warranted).

3. To compare the current state of practice with the available state of radiological art and technique. The latter should reflect nominal (reference) levels of dose that could be taken as representing at present the optimum range. Reaching an optimised level (consistent with the attainable current radiological technology), should be final objective of the exercise.

4. To reach this goal expenditures, sometimes quite high, are of course necessary. On the other hand, several simple modifications of the technique (both material and procedural) are possible which require basically very little or no capital input (stricter referral criteria, minimisation of a number of radiograms per examination, selection of appropriate projection, minimisation of fluoroscopy time, due collimation of the beam, shielding of organs, selection of optimal film/screen combination, optimal processing of the film etc, etc) [N2, I3]. With limited resources for health care in most countries it appears essential to optimise protection of the patient, to specify priorities for action and to obtain the best financial input-dose-reduction ratio. The Task Group shall carefully study both available methodology (generic and formalized optimisation) and will, hopefully, recommend adequate procedures for respective long-term action by professional societies, authorities (policy makers), hospital administrators and chiefs of radiology departments.

At this stage some remarks are warranted regarding selection of a nominal cost of a unit of collective dose for purposes of the optimisation of protection in the medical field. First, the cost of saving human life in various fields of medicine [N2] is lower than the up to now assumed cost of one manSv in other fields of radiation protection ($\approx 2 \times 10^4$ dollars). Therefore, selecting the latter, or even a higher value would, perhaps unduly, shift in most countries the resources in health protection into the less effective direction. Moreover, from the total cost of detriment per unit dose in medicine one should perhaps subtract the value of benefits accrued by the patients themselves (improved diagnosis, therefore more adequate and sometimes cheaper treatment, etc, etc). These questions, and some others, e.g. is it realistic to recommend an α value independent of expenditures for health protection per year per caput in a country, should be addressed by the Task Group.

5. The Task Group, Committee 3 and the Main Commission shall analyse and decide to what extent the question of referral criteria and the connected efficacy of individual radiological procedures shall be dealt with. In my opinion it is a difficult subject. There is, however, an obvious room for reduction of the frequency of practices and procedures of very low efficacy, provided the recommendations will avoid schematic treatment of the subject.

Elimination of a large fraction of retakes is also feasible.

6. There are specific aspects of patients protection in paediatrics, cardiology, interventional radiology, mass screening and dental radiology. In the prospective Task Groups' recommendations they should be treated in form of annexes and addressed to professionals directly concerned and active in these fields.

I believe that the task, just presented, is strategically the most basic and important among those related to the protection in medicine, being undertaken currently by Committee 3 and the Main Commission.

If implementation of prospective recommendations would result in substantial reduction of the total collective dose and within this of the avoidable fraction from medical sources by a factor = 3 or 4 (this seems quite feasible), the merit shall justify the efforts.

B. The project "Potential Exposures in Medicine".

Potential exposure has been defined in Publ. 60 as (para 127): "Not all exposures occur as forecast. There may be accidental departures from the planned operating procedures, or equipment may fail..... Such events can be foreseen and their probability of occurrence estimated, but they cannot be predicted in detail."

There is obviously a room for such exposures (patients, personnel) in medicine. There are well known, dramatic examples of this kind (related mostly to therapy): therapeutical accelerator accidents in Texas, U.S. (1986) and Zaragoza, Spain (1990), a series of accidents with ⁶⁰Co therapy units; misadministrations of therapeutic instead of diagnostic activities in nuclear medicine, etc.

Exhaustive statistics of such incidents or accidents, involving patients and sometimes also medical personnel, are not widely available. The respective working group of Committee 3 (to become most likely a task group), will collect available data on overexposures and mis-administrations (doses in therapy, radiopharmaceuticals), on dominant sources of the failures, and will try to develop recommendations aiming at reduction of the probability of their occurrence to the lowest reasonably attainable (i.e. optimised) level. The recommendations should have both technical and systemic character. The work has just started and will continue for few years.

C. Protection of humans in biomedical research.

The subject has been treated in the past both by the Commission and by other organisations (e.g. World Health Organisation)[W1]. General principles of the Helsinki accord on the subject - as amended in Tokyo in 1975 - [W2], form still an acceptable backbone of the system. Situation is relatively straight-forward in those fields where exposure to various noxae, is reflected by a threshold type dose-response relationship. Ionizing radiation is exceptional in this context as the probability of detrimental stochastic effects decreases with reduction of the dose but is not expected to reach zero level unless the dose does the same.

Assessment of the detriment vs. dose has increased in Publ. 60 by a factor 3-4 relative to that which served as basis for previous WHO documents, pronounced age effects have been documented, and new effects on human conceptus discovered. Ethical committees and other interested bodies are in obvious need for guidance in this field. Committee 3 will prepare a new document providing respective recommendations related to the diagnostic application of X rays and radiopharmaceuticals, to experimental procedures in radiotherapy and biological research, with and without actual or potential medical benefit to the participants. The Committee hopes to be able to issue the document not later than 1993, possibly still in 1992.

D. Updating dosimetric information related to radiopharmaceuticals.

A common Task Group of Committee 3 and Committee 2 works on updating information on doses incurred from radiopharmaceuticals. The subject has received extensive treatment in Publ.53 - "Doses from Radiopharmaceuticals", published in 1987 [I6]. There are, however, one or two new substances of this

kind being introduced into medical practice every year, and substantial proportion of them is going to stay with us for long time. For instance, since adoption of Publ.53 three new substances, utilizing ^{99m}Tc as the radioactive label, have been introduced into a wide use:

1/ ^{99m}Tc -MAG₃ (mercaptoacetyltriglycine) for renal functional diagnostics, and ^{99m}Tc -HmPAO (CERETEC, heksametylopropylencamineoxine) mainly for studies of the regional cerebral blood flow; 2/ ^{99m}Tc -hexakis MIBI (2-metoxiisobuthyl isonitrile) for heart perfusion studies. The latter two are administered at particularly high activities of ^{99m}Tc (500-1000 MBq) and the resulting doses need to be known. There are also other substances, like labelled fatty acids, ^{68}Ga -EDTA, labelled antibodies etc, of sufficient clinical interest to be treated similarly.

For several of these substances respective kinetic (and/or metabolic) models have been developed and organ doses calculated by the Task Group (they will be published in late 1992 or early 1993). In addition, values of E for those radiopharmaceuticals that had been included in Publ.53 will be included in the updating document, recalculated according to the currently recommended procedure, and with organ weighting factors, specified in Publ. 60. Some kinetic models will also be reviewed acc. to the fresh data (e.g. ^{201}Tl). It is perhaps interesting to note that new E values are generally lower than the old H_e , except for those radiopharmaceuticals that irradiate predominantly the thyroid gland [J10] (fig. 3); the latter E values have increased mostly due to the respective change of W_T . For radiopharmaceuticals included in Publ.53 the average value of E per unit administered activity is numerically lower by $\approx 12\%$ than the mean H_e . We hope this information will be useful for the professional community of nuclear medicine in their daily practice, and for optimisation of patients protection (selection of substances, selection of optimal administered activity).

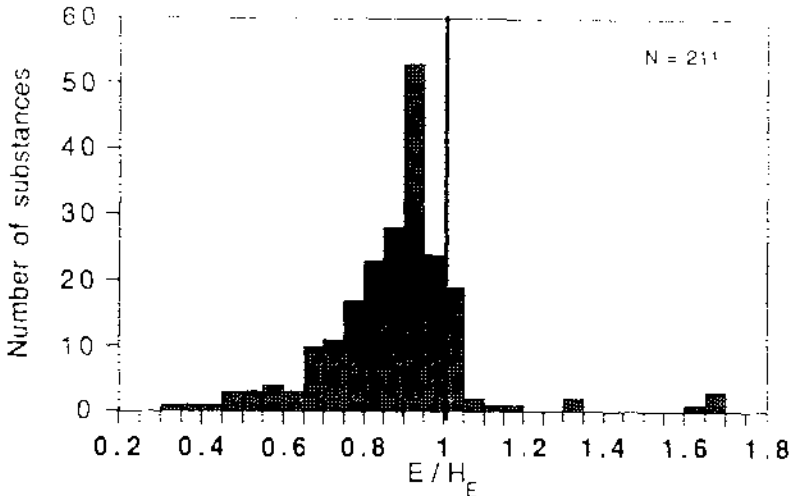

Fig.3. Distribution of the quotient effective dose (E): effective dose equivalent (H_e) using the new (ICRP 60) and old (ICRP 26) weighting factors, respectively. All substances found in ICRP 53 are included [J1].

I believe I have given you a rather detailed picture of Main Commissions' and Committee 3 activity aimed at radiological protection in medicine.

References

- I1 International Commission on Radiological Protection: Recommendation of; ICRP Publ. 26, 1977.
- I2 International Commission on Radiological Protection: Recommendations of; ICRP Publ. 60, 1991.
- I3 ICRP Publication 34 (Annals of the ICRP, Vol. 9 No 2/3) Protection of the Patient in Diagnostic Radiology
- I4 ICRP Publication 44 (Annals of the ICRP, Vol.15, No 2) Protection of the Patient in Radiation Therapy.
- I5 ICRP Publication 52 (Annals of the ICRP Vol.17, No 4) Protection of the Patient in Nuclear Medicine.
- I6 ICRP Publication 53 (Annals of the ICRP Vol.18, No 1-4) Radiation Dose to Patients from Radiopharmaceuticals.
- I7 ICRP Publication 53 (Annals of the ICRP Vol. 20, No 3) Radiological Protection of the Worker in Medicine and Dentistry.
- J1 Johanson, S.Mattson, B.Nosslin, S.Leide: Effective Dose to the Patient from Radiopharmaceuticals Calculated with the new ICRP Tissue Weighting Factors. Proc.5th Intern.Radiopharmaceutical Dosimetry Symposium, Oak Ridge, Tenn. May 7-10, 1991.
- L1 Lindskong B.A. Man standard in diagnostic radiology dosimetry 17 Intern. Congress of Radiology, Paris 1989, abst. 980 in: Radiodiagnosis abstract book.
- N1 National Research Council, Committee on Biological Effects of Ionizing Radiations. Health Effects of Exposure to Low Levels of Ionizing Radiation (BEIR V). National Academy Press, Washington, D.C., 1990.
- N2 National Radiological Protection Board. Patient Dose Reduction in Diagnostic Radiology. Documents of the NRPB, Vol. 1, No 3, Chilton, Didcot, Oxon, 1990.
- R1 I.G.B. Russell. The last illness factor: a district experience. Brit.J.Radiat. 61: 1037-1038, 1988.
- S1 Staniszevska A.M., Personal communication.
- U1 United States Department of Health and Human Services. Nationwide evaluation of X-ray trends (NEXT). HHS (FDA) 82 - 8056 (1982).
- U2 United Nations Scientific Committee on the Effects of Atomic Radiation, Sources, Effects and Risks of Ionizing Radiation 1988 Report to the General Assembly. United Nations, New York 1988.
- W1 World Health Organization. Use of ionizing radiation and radionuclides of human beings for medical research, training and nonmedical purposes. Technical Report Series 611, WHO, Geneva, 1977.
- W2 World Medical Assembly. Declaration on general ethical principles for research involving human subjects, with subsequent revision in Tokyo (1975). Full text: WHO Chronicle 30: 360-362, 1976.
- Z1 Zatoński et al, Eds. Cancer in Poland in 1988. Center of Oncology, Department of Cancer Control, Warsaw 1990.

FUTURE WORK OF ICRP COMMITTEE 2

by

Charles B. Meinhold

Abstract: ICRP Committee 2 has an exciting program in virtually all areas of importance to the development of secondary limits. Currently active task groups are working on 1) a new human respiratory tract model, 2) new data on Reference Man, 3) additional elements for age dependent dose to members of the public, and 4) and calculations for internally deposited radionuclides. A new activity is underway in collaboration with ICRU on sorting out protection quantities and metrological quantities for external exposures. All these activities have an important bearing on the next major effort, the revision of ICRP Publication 30.

The program chairman requested that we (the ICRP committee chairmen) speak to you about the future work of our respective committees. He specifically ask that we not address historical issues, meaning, I believe, the development of ICRP Publications 60 and 61.

One might expect that the committee members might feel that the work at this time is somewhat anti-climactic. You may rest assured that this is not the case. Committee 2 has an exciting program of work before it. Before describing this effort, I would like to list the other members of Committee 2: Dr. William J. Bair, Dr. A. Bouville, Prof. Dr. Chen Xing-an, Dr. Gunter Drexler, Dr. Keith F. Eckerman, Prof. Dr. Alexander Kaul, Professor Dr. Ilya A. Likhtarev, Dr. Osamu Matsuoka, Dr. H. Metivier, Dr. N. Parmentier, Dr. Chester R. Richmond, Dr. J.W. Stather, Prof. Dr. David M. Taylor, and Prof. Ralph H. Thomas.

As many of you know, Committee 2 is charged with developing the basic documents which permit the derivation of secondary limits.

The most organized approach to outlining the present and future work of this Committee is to discuss the work of each task group in some detail.

The Task Group on the Human Respiratory Tract

The objective of this task group, under the chairmanship of Bill Bair, is to develop a comprehensive, scientifically justifiable model of the human respiratory tract for use in radiation protection. It would, therefore, provide the basis for the calculation of ALI's for inhaled materials as well as enable individual and population dose assessments. The task group has written a document presenting a clear and eloquent description of the anatomy, physiology, and morphometry of the human respiratory tract. The latest data on deposition in the respiratory tract highlights the work as does the review of the latest information on clearance from the lung by both particle transport and absorption to the blood.

The material is presented in a manner that allows straightforward computer calculations of dose per unit intake as a function of the age and sex of the individual and the chemical and physical characteristics of the pollutant. The task group will, however, provide recommended parameter values of the model for occupational and environmental exposure situations.

In the important case of radon daughter exposure, a problem has surfaced in trying to reconcile lung cancer risks implied by the calculated effective dose with lung cancers actually observed, i.e., it would appear from calculations on radon daughter exposure that the incidence of lung cancer seen in the population should be far greater than predicted from the epidemiological studies to date. Perhaps, the lung risk estimate is the culprit, or maybe an unreasonably high w_R value for alpha emitters is responsible for this somewhat awkward result. Whatever the reason, Bill Bair and his task group can be expected to resolve these issues and a new report on the Respiratory Tract Model should be available in early 1993.

The Task Group on Reference Man Data for use in the revision of Publication 30

The task group on Reference Man had intended to produce a scholarly work- a worthy descendant of ICRP Publication 23. The extraordinary amount of new material and the Commission's desire for completion of the work, coupled with less outside financial support than anticipated, however, resulted in the chairman of the original Reference Man Task Group, Chet Richmond, withdrawing.

At that point, the Commission asked Committee 2 to focus on the data required for the revision of Publication 30. As a result, the terms of reference of the task group have been modified under the chairmanship of Keith Eckerman with a specific mandate to prepare a report on those aspects of Reference Man required for the revision of Publication 30. It is now anticipated that six sections of the Reference Man draft will comprise the body of the new task group work. In fact, the members of the task group are authors of these texts. The topics to be included are:

1. Anatomical and Physiological Characterization of Reference Man - with an Appendix on non-western man.
2. The Skeleton.
3. The Respiratory Tract (to be produced by the Task Group on the Human Respiratory Tract).
4. Gastrointestinal Tract.
5. Values for Gastrointestinal Absorption.
6. Hematopoietic System.

With a little luck, the document or documents on the case may be published in early 1993 as well. There are those who would like to see a complete revision of Publication 23, but specific financial support for the work is required.

Task Group on Dose Calculations

A reorganization of this major activity is taking place. Until very recently, the Commission's calculations on internally deposited radionuclides were centered at the Oak Ridge National Laboratory with assistance from other calculational groups, particularly those at the NRPB in England and the BfS in Germany. This task group, again under Keith Eckerman's chairmanship, has now been enlarged to involve representatives of these laboratories as well as others. This expanded task group will be looking at the question of how the Commission reconciles slightly different methods of computation or if, in fact, such reconciliation is needed. The overall objective is to increase the cadre of individuals willing and able to assist the Commission in this work. For example, Committee 2 expects this task group to assist in the work of the Task Group on Age-Dependent Dosimetry, the revision of Publication 30, and advice on similar calculations by other Committees and task groups.

The Task Group on Age-Dependent Dose (Committed Effective Dose per Unit Intake)

This task group, chaired by Alex Kaul, enthusiastically took on this important and difficult task. As most of you realize, ICRP Publication 56, Age-Dependent Doses to Members of the Public from Intake of Radionuclides Part 1, presents the initial work of this task group. Dose per unit intake values for tritium, carbon, strontium, zirconium, niobium, ruthenium, iodine, cesium, cerium, plutonium, americium, and neptunium have been provided for the 3-month, 1-year, 5-year, 10-year, 15-year, and adult individual. Part 2, which addresses sulfur, cobalt, nickel, zinc, molybdenum, polonium, technetium, silver, tellurium, lead, barium, and radium will be in your hands during 1992. It was held up somewhat due to the decision that the new w_T s should be incorporated and that Part 2 should also contain revised values for the elements given in Part 1, incorporating the new tissue weighting factors. In addition, since the Committee has adopted the task group's new generic bone model for the alkaline earths and lead, the biokinetic model and dose data given for strontium in Part 1 will have to be revised.

Still, the work goes on. The task group members will now take a deep breath and begin again, this time the elements will be antimony, uranium, bismuth, thorium, and iron. In addition, once the new respiratory tract report is approved by the Commission, the task group will prepare a complete set of age-dependent calculations for the inhalation case.

A major activity underway within the task group is an attempt to provide guidance on the dose to the embryo or fetus due to chronic intake by the mother prior to conception, chronic intake post

conception, and acute intakes before or during and specifically at the midpoint of the pregnancy. The task group will also likely incorporate in Part 3 a discussion of uncertainties in the dose calculations.

Revision of ICRP Publication 30

This has been a major topic of discussion within Committee 2 for some time. Fortunately, the Task Group on Age-Dependent Dose to Members of the Public from Intakes of Radionuclides has been evaluating the most recent biokinetic information for a number of elements. A working party of the Committee chaired by David Taylor has been examining the data for those elements not included in the work of the Age-Dependent Task Group. In fact, the work of all the task groups listed above is essential to this revision. New reference man data, a new respiratory tract model, the generic bone model, and the work on dose calculations are all oriented to this task. Although a formal proposal for the conduct of the work on this revision has not been prepared, a number of preliminary decisions have been taken. For example, the following elements will not be included in the revision to Publication 30: lithium, boron, palladium, neodymium, terbium, dysprosium, holmium, erbium, thulium, ytterbium, lutetium, rhenium, francium, berkelium, einsteinium, fermium, and mendelevium (this will reduce the pressure to revise ICRP Publication 38, "Radionuclide Transformation.")

With regard to chemical form, normally only those compounds encountered in occupational situations will be considered. Chemical toxicity will be included with the radionuclide data when it is important. The bone model used by the Age-Dependent Task Group for the alkaline earth metals, with the possible extension to all bone seeking radionuclides, has been adopted. The inclusion of urinary bladder among the tissues explicitly assigned weighting factors has encouraged Committee 2 to formulate biokinetic models which will meet the needs of both dosimetry and bioassay. An interesting concept developing within the Committee is that committed effective dose per unit intake is a much more useful quantity than the ALI. The revision of ICRP Publication 30 will very likely focus the presentation on dose per unit intake and still provide ALIs based on 20 mSv per year as was done in ICRP Publication 61.

ICRP/ICRU Task Group on Providing Data for Use in Radiation Protection

This joint task group under the chairmanship of Ralph Thomas will provide the information to replace ICRP Publication 51. Its secondary mission is to ensure that there is close cooperation and consistency between the ICRP and the ICRU. From the prospective of the Committee 2 chairperson, the issue is quite clear: the ICRP deals with the radiation protection quantities and ICRU deals with the metrological quantities. For example, the Q-L relationship, w_R , w_T , and effective dose are ICRP concepts, whereas absorbed dose, ambient dose equivalent, and individual dose equivalent are ICRU concepts. Completion of the work specified in the terms of reference of the task group should allow the two commissions and the practitioners, as well,

to determine if the ICRU metrological quantities meet the needs of assessing exposure against the requirements of the ICRP dose-limiting recommendations. It would appear that the work denominated in the first two terms of reference will supply the information needed, i.e., provide conversion factors for fluence to effective dose calculations for a variety of radiations and energies for reference man, woman, 15-year, 5-year, three-month old children, and provide fluence to ambient dose equivalent, directional dose equivalent, individual dose equivalent penetrating, and individual dose superficial.

In summary, I would like to reiterate that the Committee has an exciting and important program before us and the Commission is fortunate in having such excellent and dedicated scientists on its committees and task groups.

The Department of Energy Tiger Teams; Analysis
of Findings and Plans for the Future

Paul L. Ziemer, Ph.D.
Assistant Secretary for
Environment, Safety and Health
U.S. Department of Energy
Washington, D.C.

Since mid-1989, the Department of Energy (DOE) has used "Tiger Teams" to provide independent oversight and assessments of the compliance and management of environment, safety, and health programs in DOE facilities. These assessments have provided the Secretary of Energy with not only the current compliance status of each facility together with the associated vulnerabilities, but also have identified root causes for noncompliance. By mid-1992, Tiger Team assessments will be completed for all major DOE facilities (production, research, and testing facilities) as well as a number of smaller or less complex sites.

An analysis of the findings from all assessments including root causes and trends, will be presented. Particular emphasis will be placed on the technical safety appraisals of the radiation protection programs and on related industrial hygiene, occupational safety, and environment compliance issues. The emerging role of "self-assessment" offices within DOE program offices, and the subsequent changing role of independent oversight through Tiger Team assessments will be discussed.

The Department of Energy Tiger Team Analysis:
Analysis of Findings and Plans for the Future

Paul L. Ziemer, Ph.D.
Assistant Secretary
Environment, Safety and Health

Lawrence A. Weiner
Director, Office of Special Projects

U.S. Department of Energy
Washington, D.C.

ABSTRACT

Since mid-1989, the Department of Energy (DOE) has used "Tiger Teams" to provide independent oversight and assessments of the compliance and management of environment, safety, and health programs in DOE facilities. These assessments have provided the Secretary of Energy with not only the current compliance status of each facility together with the associated vulnerabilities, but also have identified root causes for noncompliance. By mid-1992, Tiger Team assessments will be completed for all major DOE facilities (production, research, and testing facilities) as well as a number of smaller or less complex sites.

INTRODUCTION

Through Tiger Team assessments implemented by the Office of Environment, Safety and Health, the Department of Energy (DOE) has provided oversight of DOE's facilities and assurance of facility compliance with environment, safety, and health (ES&H) requirements throughout the DOE complex. Tiger Teams are typically composed of at least 30 well-trained, highly qualified professionals who spend approximately three to four weeks in preparation and followup activities, and approximately four to six weeks on site during an assessment. Tiger Team assessments have worked to determine the causes as well as the symptoms of compliance issues in order to help facilities initiate appropriate changes and interact sooner with regulators.

A trend analysis of the findings from the first sixteen assessments was published in May 1991¹. This paper provides a synopsis of the key findings found during those first sixteen assessments, including root causes and trends common to the facilities. The role of on-site self assessment is addressed in this paper, and the future role of the Tiger Team assessment program is also discussed.

By June 1992, thirty-five DOE facilities will have been assessed. A final synopsis covering these thirty-five Tiger Team assessments will be completed in late 1992.

ROOT CAUSES

The common underlying causes identified by the Tiger Teams

vary in degree, ranging from probable causal factors to root causes (i.e., the cause that, when removed or corrected, will eliminate the potential for recurrence of a similar problem or incident). An analysis of all root causes revealed the following three general root causes common to a majority of the assessments:

- o ES&H compliance is not emphasized as a primary goal. Complacency or lack of attention to safety and health issues exist because workers do not perceive this to be important. Other workers feel that ES&H compliance is incompatible with research or line position duties.
- o Monitoring programs, assessment controls, and corrective action implementation programs are insufficient. A number of the reports show that the facilities have not been able to develop and implement self-assessment plans/programs. Furthermore, facilities fail to identify existing ES&H problems.
- o Management is ineffective in assessing or enforcing compliance at the facilities. Management systems and controls should be reviewed and revised to include accountability, monitoring, feedback/reporting, and oversight performance to ensure implementation of required ES&H objectives. Lack of effective management at the facilities impedes ES&H programs.

Other common root causes identified by the Tiger Teams included failure to implement Federal, state, local and DOE policy; insufficient training (especially within the Safety and Health discipline); inadequate budgetary controls; and a need for technical staff.

TREND ANALYSIS

The trend analysis revealed weaknesses and deficiencies clustered in the following six key areas:

Management and Oversight of ES&H Activities. ES&H authority and responsibilities are not clearly defined or understood. Facilities tend to operate in a reactive mode. Comprehensive management systems have not been implemented (or have been implemented slowly). Adequate self-assessment programs are lacking. Operations and Area Offices provide insufficient direct oversight of day-to-day contractor activities. Conclusion: Review/revise management systems and controls to include accountability, monitoring, feedback/reporting, and performance oversight.

Conduct of Operations/Formality and Discipline. Lack of sufficient formality and discipline exists in ES&H management systems. Conditions and practices that clearly do not satisfy ES&H requirements are accepted at DOE facilities. Conclusion: The discipline and formality of DOE's management systems must be improved.

Communication and Implementation of ES&H Policy. Although improvement is evident, ES&H policy is not being communicated to all levels of DOE and contractor staff. Policies, goals, and objectives have not reflected a strong commitment to ES&H excellence. Conclusion: A consistent set of performance expectations and technical requirements must be communicated throughout the entire system. The DOE compliance policy must be effectively implemented through orders, guidance, and employee and contractor performance objectives.

Resources/Training. Difficulties exist in securing staff with appropriate qualifications and in obtaining security clearances in a timely manner. Conclusion: Identify/document staff resource requirements. Find ways to speed up recruitment process. Additionally, expand and improve Departmental training programs.

Occupational Safety and Health. The most important areas of noncompliance found during the Department of Labor's Occupational Safety and Health (OSHA) review of nine sites included construction activities, machine guarding, and electrical safety. DOE does not have programs in place that routinely identify (let alone prevent) noncompliance with OSHA requirements. Conclusion: Immediate attention needs to be focused on workplace safety and health. The lack of importance and attention assigned by management to OSHA compliance must change.

Technical Issues. Deficiencies in the following technical areas/programs were identified: Radiological Protection, Emergency Preparedness, Waste Management, Management of Inactive Waste Sites, and Environmental Monitoring.

SELF-ASSESSMENT PROGRAMS

As noted above, many of the DOE facilities lacked adequate programs to ensure that ES&H deficiencies were identified, reported, and corrected. In particular, facilities lacked adequate self-assessment programs, and had deficient systems for reporting and tracking ES&H programs and corrective actions. All line organizations were directed to implement comprehensive self-assessment programs to identify and characterize ES&H concerns relating to their operations. Ultimate responsibility was thus placed on program senior officials.

A comprehensive ES&H self-assessment program should cover all facilities, buildings, sites, and activities under the control of the line management organization. Such a program includes all applicable disciplines under environmental protection, safety and health, and management and organization. The self-assessment program is built upon existing programs and activities including those specifically required by DOE Orders. These programs/activities include functional and management appraisals of contractors by DOE line management as well as internal appraisals conducted by contractor or, in some cases, DOE operating-level staff. In addition, management performance within the DOE line organizations is assessed.

On-site activities are assessed for compliance with Federal, state, and local laws, regulations, and permit requirements; compliance with agreements, orders, and consent decrees; compliance with executive orders and DOE orders; compliance with implementation plans developed pursuant to DOE orders; compliance with internal guidance and procedures; and conformance with other best management practices. Compliance and conformance are judged on the basis of both a review of applicable documentation and physical inspection of facilities. In addition to identifying actual compliance problems, an effective self-assessment program also includes a diagnosis of the causes of compliance problems as an aid to preventing recurrence. Full compliance with applicable regulatory requirements is the minimum acceptable level of performance. The self-assessment program is intended to be an ongoing activity, not just a one-time pre-Tiger Team visit activity.

FUTURE ROLE OF TIGER TEAMS

Beginning in October 1991, the Office of Environment, Safety and Health initiated a series of followup assessments. Team sizes were reduced, length of on-sight assessments was shortened, and the assessments became more focused, concentrating on ES&H management, ES&H corrective actions, self-assessment programs, and root-cause related issues. Small/focused assessments will continue to be phased in as larger/comprehensive assessments are phased out in the first half of CY 1992. Beginning in August 1992, larger assessments will be performed on an as-needed basis only (i.e., at potential problem facilities).

The smaller, focused assessments will include a review of self-assessment programs (from Headquarters down to the field level) and the current status of ES&H corrective actions, with the major focus on ES&H program management and root cause analysis. A Departmental Oversight Coordination Committee will establish a process/procedures to coordinate scheduling and to define the scope of future individual assessments.

Tiger Teams have been successful in providing independent oversight and assessment of the compliance and management of ES&H programs throughout the DOE complex. Future assessments will continue to help ensure that DOE operations are conducted in a manner that is safe and environmentally sound, and that protects the health and safety of the Department's employees as well as that of the public.

REFERENCE

1. DOE, 1991. Analysis of Findings from the First Sixteen Tiger Team Assessments, DOE/EH-0191, U.S. Department of Energy, Washington, D.C.

ACKNOWLEDGMENT

The authors gratefully acknowledge the assistance of Annemarie Cleary and Dartha Dragnich in preparing and editing the manuscript.

MODELES UTILISES POUR L'ESTIMATION DES RISQUES DE RADIOCANCER: LES DIFFICULTES ACTUELLES.

P. Galle

**Laboratoire de Biophysique - Faculté de Médecine
8, rue du Général Sarrail 94010 Créteil France**

STOCHASTIC MODELS AND RADIOCANCER RISKS ESTIMATES: PRESENT DIFFICULTIES

In radiation protection, models are traditionally used for the assessment of radiological risks. Proposed several decades ago for the assessment of low dose risks, stochastic models have been periodically improved. However, during the same period a number of new biological data have been obtained, many of them being not consistent with the more sophisticated mathematical stochastic models. As a result of these important biological data, there is now an excessive state of uncertainty in the risk estimates of low doses and low doses rates as obtained using traditional conservative hypothesis; these uncertainties make difficult the interpretation of both effective doses and moreover collective doses.

INTRODUCTION

Longtemps considéré comme le seul recours à l'estimation des risques de radiocancers dans les domaines de doses intéressant la radioprotection, l'utilisation des modèles pose aujourd'hui plus de difficultés qu'elle n'en résout. Loin de s'atténuer, ces difficultés se sont accrues avec le temps et il semble que l'on aboutisse maintenant à une impasse devant l'impossibilité d'intégrer dans des modèles mathématiques les acquis complexes mais cependant très solides de la biologie moderne.

Deux variétés de modèles méritent aujourd'hui une attention particulière: les modèles dits, à tort, d'extrapolation vers les faibles doses (il s'agit en fait d'interpolation) et les modèles de projection des risques sur la vie entière: par l'utilisation conjointe de ces deux variétés de modèles, on obtient en effet des résultats, et c'est sur ces résultats, considérés alors comme des acquis, que l'on se fonde aujourd'hui pour apprécier les risques et définir les normes de radioprotection.

Souvent utilisés pour apprécier ce qu'il est convenu d'appeler le niveau supérieur du risque, ces modèles fournissent des prédictions dont les incertitudes atteignent aujourd'hui des valeurs excessives, difficilement compatibles avec l'intérêt pratique recherché.

Parmi ces modèles, ceux qui apparaissent aujourd'hui les plus critiquables, et qui entraînent les plus importantes confusions sont les modèles probabilistes utilisés pour tenter d'apprécier quantitativement les risques associés à des doses faibles d'irradiation délivrées à des débits forts, moyens ou faibles. On se limitera ici à discuter les difficultés liées à ces modèles particuliers.

LES MODÈLES DITS D'EXTRAPOLATION* VERS LES FAIBLES DOSES

Rappelons tout d'abord brièvement quelles sont les données de base dont on dispose pour appliquer ces modèles, soient les seuils d'action décelable et les relations dose-effet observées aux doses moyennes ou fortes.

1) Les données de base

a) Les seuils d'action décelable

Il n'existe pas un seuil, mais toute une série de seuils correspondant chacun à une variété de cancer, une variété donnée de rayonnement et une modalité donnée d'irradiation (globale ou localisée, fractionnée ou non, fort ou faible débit). Chez l'homme les seuils les plus bas (0,3 à 0,5 Gy) ont été observés pour les rayonnements de faible TLE délivrés à débit extrêmement élevé (supérieur à 1 Gy par sec.) en irradiation totale (survivants d'Hiroshima et Nagasaki) pour certains cancers comme les leucémies (7).

Pour d'autres cancers comme ceux du rectum, du caecum, de l'os ou de l'utérus, le seuil est de 10 Gy pour les rayonnements de faible TLE délivrés à débit fort ou moyen, à doses fractionnées ou non (1).

S'agissant des faibles débits de dose, le seuil est de 0,8 Gy (dose à l'os) pour les rayonnements de TLE élevés, pour les cancers des os provoqués par les rayonnements alpha du radium (5).

On ne connaît pas, par contre, ni chez l'homme ni chez l'animal, la possible action cancérogène des rayonnements de faible TLE d'un élément aussi important que le césium irradiant à faible débit le corps entier après contamination.

b) Les appréciations quantitatives des effets observés aux doses moyennes ou fortes et leurs difficultés.

On sait que ces estimations sont imprécises et limitées à une gamme de dose trop étroite (de 0,5 à quelques Gy chez les survivants des bombes A) pour qu'on puisse les extrapoler sans l'aide de modèles. On se contente alors de faire des interpolations depuis un point de cette courbe jusqu'au point zéro. Cette interpolation est elle-même difficile car, le point d'origine est mal défini. Il ne se situe pas au niveau du seuil d'action décelable. A ce niveau, le risque ne peut pas être apprécié quantitativement compte tenu des exigences statistiques. L'appréciation quantitative ne peut donc être faite qu'à des niveaux plus élevés (de l'ordre de 1 Gy par exemple chez les survivants japonais). Rappelons ici que pour mettre en évidence, avec un intervalle de confiance de 95% un excès de 5% de leucémie, dans une population d'adultes irradiés à 0,2 Gy, l'échantillon nécessaire devrait être de 100.000 personnes auxquelles il faudrait associer un nombre identique de sujets témoins (3). Ce nombre est loin d'être atteint chez les survivants japonais: 6.375 personnes irradiées entre 0,2 et 0,49 Gy (7).

2) Les modèles utilisés et les difficultés actuelles

a) Les modèles d'extrapolation vers les faibles doses délivrées à fort débit

L'aspect quantique et le caractère essentiellement aléatoire du dépôt d'énergie radiative dans les tissus, ainsi que la très faible probabilité que l'une des 10^{14} cellules d'un organisme irradié se transforme en un cancer ont longtemps paru justifier une approche probabiliste de la radiocancérogénèse. Le choix souvent fait d'un modèle linéaire-quadratique semblait conforté par certaines données radiobiologiques rendant compte de phénomènes comme ceux observés sur cellules isolées ou chez les plantes (transdescantia).

Ces modèles sont-ils encore aujourd'hui transposables à un phénomène aussi complexe que le développement d'un radiocancer se développant au sein d'un organisme supérieur ?

Les difficultés sont les suivantes : on sait aujourd'hui que le développement d'un radiocancer est un phénomène bien plus complexe qu'on ne le supposait autrefois. Le mécanisme ne se limite pas à une lésion initiale du génome induite par un dépôt localisé d'énergie. Le phénomène est multifactoriel et de multiples étapes doivent être franchies avant que la tumeur ne se manifeste : initiation, immortalisation, promotion, formation d'un clone, prolifération de ce clone, développement de la tumeur (2, 4, 6). A chacune de ces étapes, des phénomènes stochastiques ou non, de nature enzymatique (réparation de l'ADN), hormonal ou immunologique entrent en jeux aux étapes ultérieures, favorisant ou inhibant cette progression.

Au terme de ces différentes étapes, l'aspect stochastique du phénomène initial a quasiment disparu et les modèles traditionnels apparaissent aujourd'hui inadaptés.

C'est sans doute dans les domaines de l'immunologie et de l'hormonologie que les connaissances ont le plus progressé ces dernières années. Parmi les 10^{11} lymphocytes dont nous disposons certains ont pu être individualisés: lymphocytes T cytotoxiques, cellules LAK (Lymphokine Activated Killer Cells), cellules TIL (Tumor Infiltrating Lymphocytes). Leur rôle est de supprimer les cellules anormales ou étrangères à l'organisme dont les cellules cancéreuses. Ils agissent sous l'influence d'hormones d'action locale. Ce système de défense peut être stimulé et il est capable alors de faire régresser les cancers parmi les plus redoutables. Bref l'organisme dispose d'un système d'immunosurveillance et de défense très élaboré et puissant, indispensable à sa survie. A titre d'exemple, il rend illusoire toute tentative d'extrapolation vers les doses inférieures à 1 Gy des données observées chez les survivants japonais au-dessus de cette dose à partir de laquelle ces sujets ont été dans un état d'immunodéficience par destruction des lymphocytes.

h) Les irradiations à faible débit de dose et le problème des facteurs de réduction du risque.

On connaît assez bien les effets redoutables des contaminations par les émetteurs alpha (radium, thorium) délivrés à très faible débit durant de très longues périodes, mais les données sont quasi inexistantes sur les possibles effets des rayonnements de faible TLE délivrés à ces mêmes débits, soit la situation la plus fréquente en radioprotection des travailleurs ou du public. Tenter d'estimer ces effets à partir des données observées aux forts débits est assez peu réaliste car il existe 7 ordres de grandeurs entre 1 Gy par sec. (survivants japonais) et 1 Gy par an. Dans le premier cas (20.000 ionisations par sec.

dans chaque noyau des 10^{11} cellules de l'organisme soit 2×10^{11} ionisations), les mécanismes de défense enzymatiques (réparation de l'ADN) ou immunologiques sont dépassés alors qu'ils fonctionnent normalement dans le deuxième cas, dans lequel le débit de dose (10^{11} ionisations par sec.) se rapproche de celui de l'irradiation naturelle (10^9 à 10^7 ionisations par sec. chez un homme de 70 kg).

Le facteur de réduction qu'il conviendrait d'appliquer ici est complètement inconnu car les données dont on dispose aujourd'hui sont très insuffisantes pour en donner une estimation même très approximative.

CONCLUSION

L'utilisation des modèles pour l'estimation des risques de radiocancers se heurtent à des difficultés plus importantes qu'autrefois. Conscients de ces difficultés, les comités internationaux ont adopté des attitudes conservatrices, définissant ce qu'il est convenu d'appeler le niveau supérieur du risque. Cette attitude certes légitime ne doit pas cependant masquer les difficultés actuelles. Certes les risques liés aux doses plus fortes que 1 Gy sont connus avec une précision meilleure qu'autrefois mais, dans le même temps les incertitudes concernant les plus faibles doses se sont considérablement accrues pour atteindre des valeurs excessives. Il résulte de ces incertitudes que la notion de dose efficace, ne tenant pas compte des débits de dose, devient d'interprétation difficile, de même et surtout que la notion de dose collective entièrement fondée sur l'hypothèse d'une interpolation linéaire.

L'estimation scientifique du risque de radiocancers a longtemps reposé sur le recours à des modèles mais l'aspect scientifique s'est progressivement estompé en même temps que son aspect pratique et la question peut être posée aujourd'hui de l'opportunité d'utiliser des méthodes plus simples mais plus réalistes pour l'estimation du risque radiologique et la définition des doses biologiquement efficaces.

REFERENCES

1. Boice JD. and all. Radiation dose and second cancer risk in patients treated for cancer of the cervix. *Radiation Research*, 116:3-55 (1988)
2. Galle P. Les modèles utilisés pour l'estimation des risques de radiocancer: les difficultés actuelles. *Radioprotection* 26:15-23 (1991)
3. Goss SG. Sizes of population needed to detect an increase risk when the levels of risk in the exposed and the controls are specified: examples from cancer induced by ionizing radiation. *Health Physics* 29:715-721 (1975)
4. Latarjet R. Implications biologiques de l'optimisation des irradiations. *Radioprotection* 18:155-163 (1983)
5. Raabe OG. Comparison of the carcinogenicity of radium and bone-seeking actinides. *Health Physics* 46:1241-1248 (1984)
6. Risques de rayonnements ionisants et normes de radioprotection. Académie des Sciences, rapport n° 23 (1990)
7. Shimizu Y., Kato H., Schull WJ. Studies of the mortality of A-bomb survivors. *Radiation Research* 121:120-141 (1990)

A PROPOSED FRAMEWORK FOR CONSISTENT REGULATION OF
PUBLIC EXPOSURES TO RADIONUCLIDES AND OTHER CARCINOGENS*

D. C. Kocher and F. O. Hoffman
Oak Ridge National Laboratory
Oak Ridge, Tennessee 37831, U.S.A.

ABSTRACT

This paper discusses a proposed framework for consistent regulation of carcinogenic risks to the public based on establishing *de manifestis* (i.e., unacceptable) and *de minimis* (i.e., trivial) lifetime risks from exposure to any carcinogens at levels of about 10^{-1} - 10^{-3} and 10^{-4} - 10^{-6} , respectively, and reduction of risks above *de minimis* levels as low as reasonably achievable (ALARA). We then discuss certain differences in the way risks from exposure to radionuclides and other carcinogens currently are regulated or assessed which would need to be considered in implementing the proposed regulatory framework for all carcinogens.

INTRODUCTION

We believe there is a fundamental problem with current regulatory policies in the United States for limiting routine exposures of the public to radionuclides and other carcinogens - namely, a clear inconsistency in the levels of acceptable health risk associated with (a) standards for radionuclides only, as developed under authority of the Atomic Energy Act, and (b) standards for any carcinogens, including radionuclides, or for chemical carcinogens only, as developed under authority of other laws. We first describe the apparent inconsistency in the levels of acceptable risk associated with these two categories of standards and propose a set of principles, based on distinguishing unambiguously between unacceptable and trivial risks, which could provide more consistent regulation of carcinogenic risks to the public. The present inconsistency in acceptable risks and our proposed regulatory framework are discussed in more detail elsewhere [1]. We then discuss other differences in the way risks from exposure to radionuclides and other carcinogens currently are regulated or assessed which would need to be considered in implementing the proposed regulatory framework for all carcinogens.

INCONSISTENCY IN CURRENT REGULATORY APPROACHES

The current framework for regulating radiation exposures of the public under authority of the Atomic Energy Act may be referred to as a "top-down" approach. In this approach, a limit on radiation dose to individuals from all sources of exposure except natural background, corresponding to an upper bound on acceptable risk, is established in radiation protection standards. Then, doses are reduced below the limit by requiring that exposures be kept as low as reasonably achievable (ALARA), taking into account such factors as cost vs. benefit, technical feasibility, and societal concerns (e.g., perceptions of risk).

* Research sponsored by the U.S. Department of Energy under contract DE-AC05-84OR21400 with Martin Marietta Energy Systems, Inc.

The submitted manuscript has been authored by a contractor of the U.S. Government under contract No. DE-AC05-84OR21400. Accordingly, the U.S. Government retains a nonexclusive, royalty-free license to publish or reproduce the published form of this contribution, or allow others to do so, for U.S. Government purposes.

The current dose limit in radiation protection standards for the public corresponds to a limit on acceptable lifetime risk of 5×10^{-3} [2]. However, the development in the United States of many standards for specific practices or sources, which represent an application of the ALARA principle, virtually assures that lifetime risks from routine exposures to all man-made radionuclides will not exceed 10^{-3} . The "top-down" approach also is applied to (a) regulation of exposures to naturally occurring radionuclides in mill tailings, (b) remedial action levels for exposure to natural background, principally radon decay products and external radiation, and (c) responses to radiation accidents. In these cases, the limit on acceptable lifetime risk is in the range 1×10^{-3} to 5×10^{-2} , and the ALARA principle is applied to reduction of public exposures.

The current framework for regulating exposures of the public to chemical carcinogens, and for regulating radiation exposures under authority of laws other than the Atomic Energy Act, is quite the opposite of that described above and may be referred to as a "bottom-up" approach. In this approach, there is no standard defining an upper bound on acceptable risk from all carcinogens and sources of exposure. Rather, for specific exposure situations only, a lower bound on acceptable risk is established as a goal, and this goal then may be increased to reflect risk levels that reasonably can be justified.

The "bottom-up" approach is exemplified by current laws and regulations for carcinogenic food additives (e.g., pesticides) and for radionuclides and chemical carcinogens in drinking water. In both cases, a carcinogenic risk of zero has been established as a goal, but this goal has been relaxed to permit lifetime risks up to 10^{-6} for pesticides and 10^{-4} - 10^{-6} for carcinogens in drinking water. Acceptable risks in the range 10^{-4} - 10^{-6} from exposure to radionuclides and other carcinogens also are embodied in standards for airborne emissions of hazardous substances and standards for cleanup of hazardous substances in the environment, e.g., at old waste disposal sites.

The "top-down" approach to regulating radiation exposures under authority of the Atomic Energy Act clearly is fundamentally different from the "bottom-up" approach to regulating exposures to radionuclides and other carcinogens under authority of other laws. Consequently, upper bounds on lifetime risks to the public regarded as "acceptable" clearly are inconsistent in the two cases - i.e., risks of 10^{-1} - 10^{-3} in the former but 10^{-4} - 10^{-6} in the latter.

PROPOSED FRAMEWORK FOR CONSISTENT REGULATION OF ALL CARCINOGENS

In order to reconcile the fundamental inconsistency in regulatory approaches described above and to provide more consistent regulation of carcinogenic risks to the public, we propose an explicit regulatory framework for all carcinogens which contains three basic elements:

- [1] a *de manifestis* lifetime risk in the range 10^{-1} - 10^{-3} , which would define an upper bound on acceptable risk from all carcinogens and sources of exposure and above which regulatory action would be taken to reduce risks regardless of cost;

- [2] a *de minimis* lifetime risk in the range 10^{-4} - 10^{-6} , which would define risks from any carcinogen and source of exposure so trivial that regulatory action to reduce risks would be unwarranted; and
- [3] reduction of lifetime risks above *de minimis* levels based on application of the ALARA principle.

The key to our proposal is to recognize that the lifetime risks of 10^{-4} - 10^{-6} embodied in some standards, as described previously, are *de minimis* rather than *de manifestis* levels. This interpretation is clearly supported by an analysis which showed that regulatory authorities in the United States usually have not acted to reduce risks from chemical carcinogens when the lifetime risk to a few individuals is below 10^{-4} and the average lifetime risk in large populations is below 10^{-6} [3].

The proposed use of ranges for the *de manifestis* and *de minimis* risks would permit taking into account the size of an exposed population in establishing these levels for particular situations [3] and would allow considerable flexibility in applying the ALARA principle. Therefore, complete uniformity of regulatory decisions in limiting carcinogenic risks to the public would not be required.

As indicated previously and discussed in more detail elsewhere [1], our proposed regulatory framework is consistent with virtually all current regulatory policies for limiting routine and accidental exposures of the public to radionuclides and other carcinogens, including proposed exemption levels for radiation exposure. Again, however, this consistency is achieved only if the lifetime risks of 10^{-4} - 10^{-6} embodied in some standards are interpreted as *de minimis*.

We believe that our proposed regulatory framework would encourage consideration of risks from any carcinogen and source of exposure in the context of risks from all sources, as opposed to the rather piecemeal approach embodied in past regulatory decisions, particularly for chemical carcinogens [3]. Furthermore, the proposed *de minimis* levels would ensure that risks much less than largely unavoidable background risks, which average about 10^{-2} for radionuclides [2,4] and greater than 5×10^{-3} for chemical carcinogens [5], do not receive unwarranted attention.

ADDITIONAL CONSIDERATIONS IN IMPLEMENTING PROPOSAL

Implementation of our proposed regulatory framework for limiting risks to the public from all carcinogens would require additional considerations as a result of certain other differences in the way risks from radionuclides and chemical carcinogens are regulated or assessed.

First, the *de manifestis* and *de minimis* levels are expressed as lifetime rather than annual risks. This approach assumes that stochastic health effects are the primary concern in regulating exposures of the public to any carcinogens. Thus, the common practice of apportioning an assumed limit on lifetime risk into equal annualized increments in setting dose limits in radiation protection standards is rather arbitrary for purposes of limiting stochastic risk. Subsidiary limits on acute

exposures to any carcinogens would be needed only if prevention of nonstochastic (i.e., deterministic) effects is of concern.

Second, there are inconsistencies in the factors for converting exposure to risk. In particular, radiation risk factors usually are best estimates [2], but upper 95th percentile confidence limits are used for other carcinogens [6]. In addition, radiation risk factors take into account risks from irradiation of all organs and tissues [2], but current risk factors for chemical carcinogens usually take into account only one organ or tissue at risk [6].

Third, the primary measure of risk from radiation exposure usually has been cancer fatalities [2], whereas the primary measure of risk for other carcinogens has been cancer incidence [6]. Risk factors for radiation exposure that include weighted nonfatal cancers as well as fatal cancers have been introduced [2], and a similar approach could be used in developing risk factors for chemical carcinogens.

Finally, in assessing radiation doses to maximally exposed individuals, the intent usually is to estimate average doses to members of critical population groups using reasonable assumptions for likely exposure scenarios and pathways. However, risk assessments for chemical carcinogens often emphasize unreasonably pessimistic assumptions [6], and the resulting estimates of risk may exceed values that could be experienced by any members of the public.

REFERENCES

1. Kocher, D. C. and Hoffman, F. O., 1991, Regulating Environmental Carcinogens: Where Do We Draw the Line?, Environmental Science & Technology (December, 1991).
2. International Commission on Radiological Protection (ICRP), 1991, 1990 Recommendations of the International Commission on Radiological Protection, ICRP Publication 60, Annals of the ICRP, 21, No. 1-3.
3. Travis, C. C., Richter, S. A., Crouch, E. A. C., Wilson, R. and Klema, E. D., 1987, Cancer Risk Management: A Review of 132 Federal Regulatory Decisions, Environmental Science & Technology, 21, pp. 415-420.
4. National Council on Radiation Protection and Measurements (NCRP), 1987, Ionizing Radiation Exposure of the Population of the United States, NCRP Report No. 93, NCRP, Bethesda, Maryland, U.S.A.
5. Travis, C. C. and Hester, S. T., 1990, Background Exposure to Chemicals: What Is the Risk?, Risk Analysis, 10, pp. 463-466.
6. U.S. Environmental Protection Agency, 1989, Risk Assessment Guidance for Superfund. Volume 1. Human Health Evaluation Manual (Part A), EPA/540/1-89/002, Washington, D.C., U.S.A.

Systems to Measure Airborne Radioactive Substances in the Reactor Containment in Event of a Severe Accident

R. Hock, Siemens; H. Eisgruber, RWE; G. Kalber, VGB

Abstract

In the event of a major release of radioactive substances into the containment atmosphere, the presence of aerosols and iodine may pose a larger threat than the noble gases. They tend to deposit in sampling lines to a varying degree. This makes precise measurement difficult, particularly if small volumes have to be handled, because of high activity. Most systems on the market do not solve these problems. Four different systems have been evaluated and optimized with respect to this task. They allow sufficiently accurate measurement of these substances in the containment atmosphere over a wide range of conditions and temperatures (dry atmosphere up to 100% steam

In the event of a major release of radioactive substances into the atmosphere of a reactor containment, countermeasures inside and outside the plant can only be optimized if the actual potential radiological hazard can be determined.

Substances which accumulate in the human body and are deposited in the biosphere represent a higher potential hazard than gases with low or no reaction with other substances. It is therefore important to know the actual concentration particularly of these substances. Even if they are absent or at low levels it is important to be aware of that fact. Countermeasures usually pose other hazards and therefore they have to be optimized, which is only possible if the actual threat is known.

In contrast to noble gases, the concentrations of aerosols and airborne iodine not only depend upon the degree of core degradation but also on a number of other parameters which are unlikely to be known in the actual case. "Conservative assumptions" which are meaningful for the design of protective devices may lead to wrong decisions in an actual case as has been demonstrated in the assumed radiolysis during the accident at TMI.

It is therefore important that a wide range of concentrations of these substances can be measured even in the presence of a high background of radioactive noble gases. This background of noble gases can easily be estimated at an early stage from a dose rate measurement inside or close to the containment. Only within the first hours of an extreme event may aerosols contribute significantly to that dose rate. Fig.1 shows the dose rate which would result from the various substances at a distance of 50 cm from just 1 ml containment atmosphere. Their relative contribution to the radiation from the entire containment is approximately the same. In addition this figure shows how large a volume could be handled safely in such an extreme situation.

The measurement of aerosols and airborne iodine may be distorted by their tendency to deposit on surfaces in sampling lines. The degree of such deposition is highly dependent on the velocity, particle size distribution, temperature and material. Because some of these parameters are not known in the actual case correction factors may be highly inaccurate. Fig.2 gives an example of these effects. The losses of aerosols (diameter 5 μ) and elemental iodine have been calculated as a function of the velocity for a specific configuration of a slightly heated sampling line to avoid condensation.

The losses in the sampling line are tolerable at a specific velocity only.

Losses in unheated sampling lines could become extremely high if steam is present in the containment atmosphere: If the sampling line passes through cooler areas the inner surfaces may become wet. This would effectively filter out these substances. Depending upon the actual conditions varying with time and location, this liquid may reach the sampling station hours later. It could then show a concentration in the containment which may not exist any more at that time due to deposition and washout effects.

It has been decided by those German utilities operating nuclear power stations that they want to obtain more accurate measurement results for these most important substances and that it should be made possible to perform the analyses in the radiochemical laboratory using routine methods. In a high-stress situation such routine methods are less prone to operator error.

Existing systems were first analyzed and found not to meet these requirements. Then four different systems were selected for more detailed investigation and development according to the given specification. All of them now meet the requirements.

In system 1 the sampling lines are heated to prevent condensation. The flow is regulated independently of the pressure within the containment. Directly outside the containment noble gases are separated from the other substances by a washer (Fig.3). A small sample of the gas and the water phase will be taken remotely without further losses by deposition in sampling lines. This fraction will then be further diluted for analysis in the laboratory.

In system 2 a small sample is taken by means of a container which is transported by a shuttle system to a location inside the containment (Fig.4).

The essential part of system 3 is a remotely operated snapper inside the containment which also takes only a small sample (Fig.5). In contrast to system 2, it operates with a liquid transport medium. Substances which are airborne in the containment are transported as a gas bubble or dissolved or suspended in the liquid. Temporarily deposited substances would immediately be resuspended or dissolved by the circulating fluid. This fluid simultaneously dilutes the high concentrations.

In system 4 the gases and other substances are separated by a gas washer within the containment (Fig.6). This washer operates without condensation because it is at the same temperature as its environment. Gases which pass the washer together with steam and/or air are analyzed first. The other substances will remain in the washing liquid. At the end of a short sampling period part of the liquid will be taken to the outside and the concentrations will be determined. Because the volume of the liquid and the containment volume which has passed the washer are known, the concentrations in the containment atmosphere can be evaluated.

Each of these systems tolerates extreme concentrations of radioactivity as well as a large variety of conditions with respect to temperature, pressure and composition (from 100% air to 100% steam). Which system is the optimum depends on the specific circumstances of the plant, e.g. the number of required measuring points in the containment, the distance to the nearest location accessible after a major release of radioactive substances within the containment and the availability and cost of isolation/transfer valves through the containment.

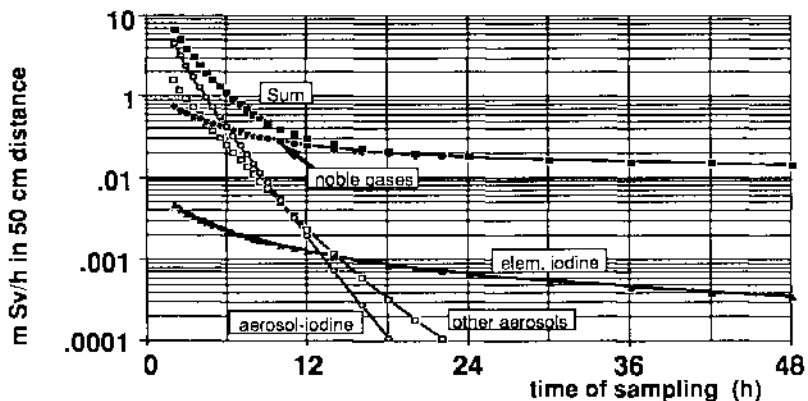

Fig. 1 Dose rate caused by 1 ml BWR containment atmosphere after a severe core melt accident

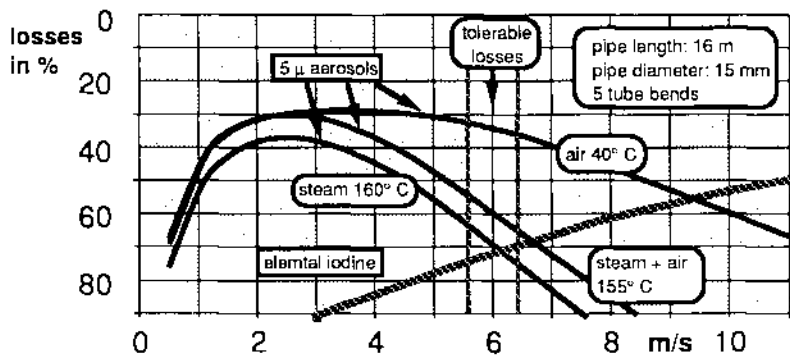

Fig.2 Losses in a sampling line as a function of sampling velocity (m/s)

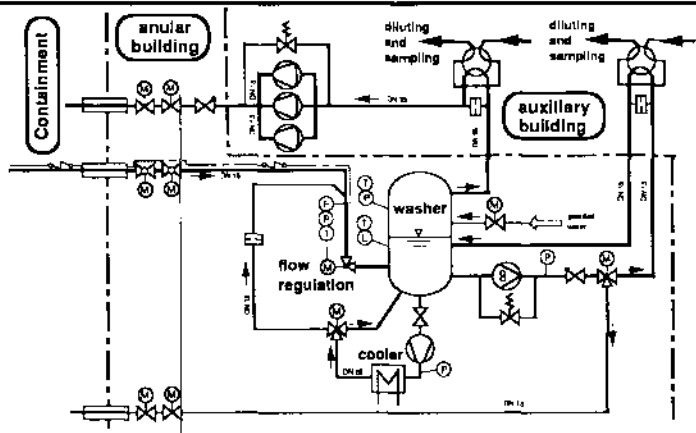

Fig.3 Sampling System for the Containment Atmosphere (System 1)

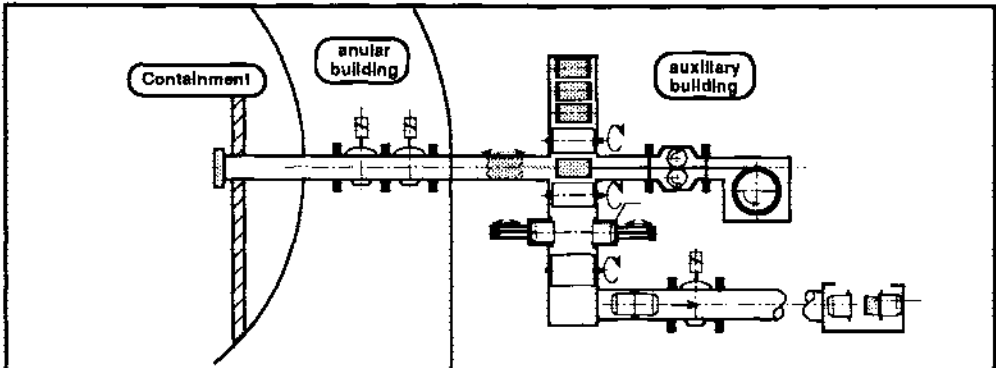

Fig.4 Sampling System for the Containment Atmosphere (System 2)

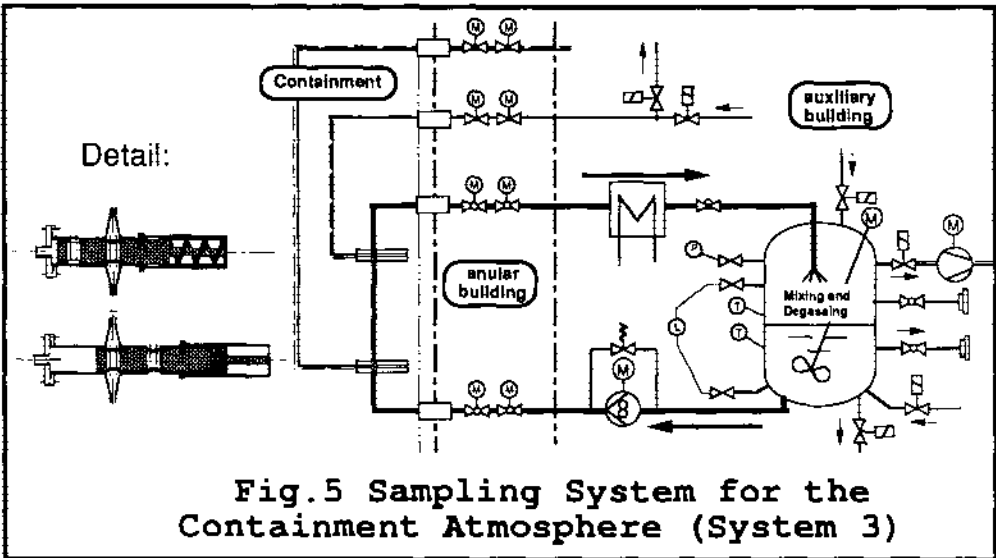

Fig.5 Sampling System for the Containment Atmosphere (System 3)

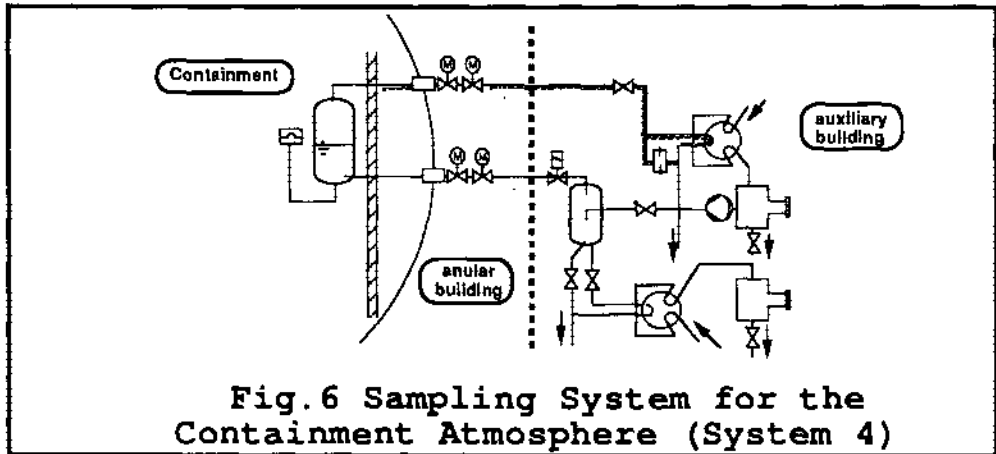

Fig.6 Sampling System for the Containment Atmosphere (System 4)

RADIATION PROTECTION LEGISLATION IN THE NORDIC COUNTRIES

Lars Persson

Swedish Radiation Protection Institute, Box 60204, S-10401
Stockholm, Sweden

ABSTRACT

A close collaboration exists in the Nordic countries in the field of radiation protection. The radiation protection authorities attach major importance to a uniform interpretation of the international recommendations. The legal situation of the Nordic countries in the radiation protection field will be reviewed with the main emphasis on the new Swedish and Finnish laws.

INTRODUCTION

The Nordic radiation protection authorities attach major importance to a uniform interpretation of the international recommendations. However, no attempt has been made to formulate identical laws and regulations for all the five countries, since the legal and administrative framework of the five Nordic countries differs. A survey of the Nordic co-operation in radiation protection is available in ref (1).

DENMARK

The X-ray law was enacted already 1930 and the Radiactive Substances law in 1953. The laws are supplemented with orders issued by the National Board of Health. In refs (1), (2), and (3) the orders until end of 1990 are reviewed. In 1991 the following order is published:
No 319. On electron accelerators for the treatment of patients with energies from 1-50 MeV.

FINLAND

The new law published as no 1991:592 will come into force on 1st January 1992. The scope of the new Finnish law is rather extensive. Except for the utilization of radiation, it shall apply to activities involving exposure to natural radiation and non-ionizing radiation. Its basic objective is to protect human health.

The generally approved basic principles of radiation protection are contained in the law as the guiding principles of regulatory control:

- justification,
- optimization of radiation protection (ALARA), and
- individual dose limitation.

Any licenced employer using radiation or whose activities involve exposure to radiation shall be responsible for the safety of the activity. Any carrying out such an activity shall

with radiation. The employees are, in turn, obliged to collaborate in maintaining radiation protection.

The new law contains provisions concerning radioactive waste. The starting point has been that the same requirements should apply to all radioactive waste, regardless of whether it comes from nuclear or other operations. According to the model in the Swedish law on nuclear activities, the new law therefore lays down that persons conducting activities involving radiation must be responsible for the handling of radioactive waste and its storage in a satisfactory manner. Another similar rule is the scrapping of equipment that may produce radiation. A source of X-ray radiation may, for example, constitute a hazard by being connected to the electricity grid. In view of this, it is prescribed that equipment capable of generating hazardous radiation must, before being scrapped, be rendered harmless.

According to the radiation protection law, a licence is in principle required for activities involving sources of ionizing radiation. Where non-ionizing radiation is concerned, the principle is that a licence for such activities involving the source of radiation is required only after a specific decision by the Swedish Institute of Radiation Protection.

According to the new law, penalties may be imposed both for intentional offences and for offences committed as a result of negligence. Depending on the seriousness of the offence, the penalty may vary from a fine to imprisonment for a maximum of two years.

According to the statement issued by the Parliament, it is essential for the main responsibility for radiation protection to be concentrated in a single radiation protection authority (the Swedish Institute of Radiation Protection). The intention is that the law should, in many respects, obtain its specific content from regulations imposed by the Institute.

REFERENCES

1. Persson, L., 1987, Radiation Protection and Atomic Energy Legislation in the Nordic Countries, SSI-report 87-34, Swedish Radiation Protection Institute, Stockholm.
2. Persson, L., 1990, Radiation Protection Legislation in the Nordic Countries, SSI-report 90-13, Swedish Radiation Protection Institute, Stockholm.
3. Persson, L., 1991, Radiation Protection Laws in the Nordic Countries, SSI-report 91-10, Swedish Radiation Protection Institute, Stockholm.

ACKNOWLEDGEMENTS

My sincere thanks go to the legal experts of the five Nordic radiation protection authorities for sending me the relevant documents.

The purpose of the new law is to protect people, animals and the environment against the harmful effects of ionizing and non-ionizing radiation. Ionizing radiation is defined in the law as the radiation of gamma rays, X-rays and particles or other radiation with similar biological effects, i e with such a high energy content that, in passing through materials, it is capable of releasing ions. Non-ionizing radiation is defined as optical radiation, radio-frequency radiation, low-frequency electric and magnetic fields and ultrasound or other radiation with similar biological effect. The law covers radiation that is both natural and produced or caused by human action.

The new law contains regulations concerning general obligations to be observed with respect to radiation protection. These regulations cover both ionizing and non-ionizing radiation. The central provisions concerning general obligations apply to persons conducting activities involving radiation. It is incumbent on such persons not only to follow the directives and conditions laid down but also, on their own initiative, to take all the measures required to maintain radiation protection. The duties of the person responsible therefore include planning and arranging activities in a manner that is acceptable from the viewpoint of radiation protection. Radiation protection must conform to a reasonable extent with technical development and be improved as new opportunities are afforded by development. The person responsible for activities must organize all the work in such a way that exposure to radiation is as low as may be reasonably demanded. This responsibility covers both employees engaged in the activity concerned and outsiders.

One obvious prerequisite of all activities involving radiation is that the person conducting the activities concerned is skilled in handling the equipment and the source of radiation. The training requirements must simultaneously be defined according to the potential hazardousness of the source of radiation, the nature of radiation protection and the other circumstances that may affect radiation hazards in a factory, or in the handling of radioactive substances. The provision may also entail, for example, a duty on the part of persons conducting activities involving radiation to ensure that the doses of radiation to which employees are exposed are registered. This may be done by general monitoring of the radiation level in the work premises or by measurements of doses received by individuals.

One important element in radiation protection is that facilities, premises, machinery and other technical devices, as well as protective equipment, are continuously checked and well maintained. This responsibility is included in the duties to be observed by the person conducting activities involving radiation.

According to the law, persons conducting activities involving radiation should, by means of clear and comprehensible instructions, signs or in some other way obtain a good knowledge of the conditions under which the activities are conducted and be informed of the risks that may be associated

thus be responsible for the safe performance of the activity and for having available the appropriate expertise.

The so-called safety license sets the basis for the regulatory control of the utilization of radiation. The licensing procedure is intended for ensuring that

- radiation is used sensibly and acceptably,
- radiation equipment and shields are technically acceptable,
- the operating personnel and organization are competent, and
- radioactive waste is appropriately taken care of.

Type testing is a form of regulatory control which applies to i a radiation sources used as consumer goods and many devices producing non-ionizing radiation.

The law also contains provisions concerning i a patient safety, monitoring of natural radiation, radiation work as well as radioactive waste.

Finland has a modern nuclear energy law which entered into force in 1988 on which the enforcement of the regulatory control of the use of nuclear energy mainly rests. Therefore, the provisions of the radiation protection law which apply to the use of nuclear energy are restricted to:

- The requirements concerning justification, optimization and individual dose limitation apply to nuclear energy, too. By virtue of the radiation protection law, maximum radiation doses are confirmed by which individual dose limitation is implemented, and
- The monitoring and registration of doses of nuclear power plant workers shall comply with the radiation protection law.

The Finnish Centre for Radiation and Nuclear Safety is entrusted with the enforcement of the regulatory control.

ICELAND

The Radiation Protection Act and its complementary ordinance were issued in 1985 and 1986, ref (1). In ref (2) the regulations published since then are reviewed.

NORWAY

The radiation protection law relating to the use of x-rays and radium, etc. published in 1938 has remained unchanged since then, ref (1). The complimentary Royal decrees and regulations are reviewed in refs (1) and (2). Recently the process has started to propose a new law to the Norwegian parliament.

SWEDEN

With effect from 1st July 1988 a new radiation protection law came into force in Sweden. In ref (2) the legal text of the act and its complementary ordinance is given. Regulations issued by the Swedish Radiation Protection Institute are reviewed in refs (1), (2), and (3).

QUANTIFICATION OF RADIATION DETRIMENT

GAM Webb and JD Robb

National Radiological Protection Board
Chilton, Didcot, Oxon. OX11 0RQ, UK

The quantification of the various components of radiation induced detriment has been developed by ICRP in particular over a number of years. In Publication 60 the process reached a level of development such that weighted detriment judgements are a fundamental component of the definition of one of the primary dosimetric quantities, Effective Dose, and were used explicitly in reaching a recommendation on dose limits. There is still some way to go in the further development and application on the concept of quantified detriment and this paper explores both the problems and some possible avenues to solve them.

HISTORICAL INTRODUCTION

The recently revised ICRP recommendations⁽¹⁾ have seen the Commission apply quantitative measures of detriment to several areas in order to support their recommendations. This is clearly a more extensive use of the detriment concept than has hitherto been seen in radiological protection. It has however, taken a number of years to get to this stage as, after all, detriment was initially introduced in ICRP Publication 26⁽²⁾. Here it was defined as the mathematical 'expectation' of the harm incurred from an exposure to radiation, taking into account not only the probability of each type of deleterious effect, but also the severity of the effect. These deleterious effects included both effects on health and other effects.

In practice though, attempts to quantify detriment thereafter were limited. The one area where some progress was made was the monetary costing of detriment for cost-benefit analysis (CBA) and optimisation purposes.⁽³⁾ We at NRPB used a pragmatic variation of the ICRP recommendations on detriment to derive monetary values of unit collective dose for general use in CBA. The objective health detriment was calculated by estimating the gross economic loss associated with the latent fatal and non-fatal stochastic effects. To this a multiplying factor was added to reflect individual aversion to increasing levels of individual dose. Although the application of CBA is limited to its use in optimisation studies,⁽⁴⁾ we have not for some years gone further in accounting for the severity of radiation-induced effects in other formal advice, until recently that is.

ICRP PUBLICATION 60

ICRP have clarified that for radiological protection purposes detriment should be taken to include primarily the risk to health, and that a separate allowance within a decision-making process should be made for other forms of detriment. The two principal purposes for which aspects of detriment are now quantified are for the definition of effective dose, and to assess the consequences of continued or cumulative exposure in order to recommend dose limits.

In the definition of Effective Dose, the radiation weighting factors are primarily determined by scientific judgements based on physical or biological observations. For tissue weighting factors, however, the probability of fatal cancer in each organ is weighted for relative loss of life should a cancer occur in that organ. This is adjusted further using the probability of non-fatal effects in each organ weighted by the severity of each cancer type, using a quantified form of the judgement that the relative importance of a non-fatal cancer is inversely proportional to the curability. In addition provision has been made for a more structured weighting of the hereditary consequences although for the present definition a reasonably straightforward judgement has been included. Thus the familiar quantity, Effective Dose, that some might even have considered a 'physical' quantity, is loaded with judgements as to the quantification of detriment.

To assess the consequences of continued exposure at a number of given dose regimes, the Commission quantified these elements together with some others such as years of life lost and the age at which the fatality would occur to construct a multiattribute assessment of the detriment. Based on these measures and further judgements as to their relative importance, a recommendation was made as to suitable dose limits.

CURRENT WORK

The amount of detail on detriment that can be calculated requires commensurately detailed research tools to carry out the analysis, and to examine the implications for standards in different exposure situations. NRPB has developed a PC-based computer code that allows rapid assessments of detriment assuming radiation exposure over a chosen time period to individuals or to a population⁽⁵⁾. This is based on health effects models for the UK⁽⁶⁾, currently under revision. The beauty of such tools is that the consequence of varying the weights on the different aspects of health detriment is immediately apparent. The combination of calculational speed and sensitivity analysis, allied to simplicity of use is transforming risk analysis in radiological protection.

However, the danger is that this power becomes addictive. The more detailed the analyses, the more numbers that can be produced without stopping for breath to assess the information. In the context of radiation detriment, there are three clear aspects to be addressed.

1. For what quantities and/or judgements is the quantification of detriment important ?
2. What attributes of detriment are of interest for each of these ? The same attributes, or the same aggregation will not be important in all areas. Indeed, it may be that some quantities are relatively insensitive to the inclusion or the weighting of, certain detriment factors, which therefore are an added complication where simplicity would be preferable.
3. What criteria should components of detriment be assessed against ?

Answering any one of these questions is a formidable task in itself. Here we make no attempt to do so for naturally this represents a long-term work programme. Instead, we focus on two related aspects. Firstly, the final point above, risk criteria, has to be a matter of concern, and is discussed below. Secondly, ICRP 60 introduced the term 'constraint' as

an aid to the optimisation process. We discuss here what attributes of detriment may be important in deriving these.

Risk criteria

The two key reference points for risk criteria in the UK are the study group report of the Royal Society⁽⁷⁾ and the Health and Safety Executive's document developing a philosophy of risk control⁽⁸⁾. These bodies have suggested 'acceptable' and 'tolerable' annual levels of death probability for occupational and public circumstances. These criteria have been useful, but for a full consideration based on detriment, additional questions arise.

For example, because the risk rate varies with time, it is necessary to consider whether it is the average or maximum annual risk that is important, or whether it is the age of reaching a particular risk rate that is more relevant to the judgement on acceptability. Another consideration would be whether there is a maximum acceptable lifetime risk irrespective of the time distribution of that risk. Following exposure, most of the risk of additional cancer death arises at older ages. Is there then an argument that risk at different ages should be treated differently? It could be said that the risk of premature death should be weighted more heavily because, beyond normal life expectancy, the cause of death becomes less relevant. Also in this context, we have tended to concentrate on incremental increases in death rates rather than looking at the relative increase in death and cancer death rates. This aspect may become a more important focus.

So far we have only dealt with fatal effects. We have not started to develop criteria against which one can assess the significance of non-fatal cancer, hereditary effects, years of life lost and impaired, and aggregated detriment. Weighted detriment assumes that acceptability of other effects can be assessed on the same scale as fatal effects, but this is for the moment only a working assumption.

Detriment and Dose Constraints

As noted above a number of aspects of detriment were taken into account by ICRP in making a judgement on appropriate dose limits. The general nature of the dose limits means that fairly broad assumptions are made concerning individuals, and the population groups for whom the limits are intended to apply. Dose constraints are intended to be more sector specific, derived using levels of reasonably achievable individual dose. However, although partitioning of work categories is not straightforward, and inevitably there will be overlaps, this narrowed specification means that considerations other than recorded levels of dose become important. For instance, there is a clear difference in the induced detriment per unit dose between a population of industrial radiographers, and a population of radiotherapy nurses. Moreover, for medical exposure, there are specific procedures, or situations, where solely paediatric, obstetric or geriatric exposure is practiced. For these also the detriment incurred per unit dose will clearly differ. The question is whether, and by how much should this influence the numerical choice of constraint.

What is needed therefore is a thorough review of exposure groups to determine both current levels of recorded dose and the detriment that this implies to average members of each population. This would then be fed into the decision-making process for the setting of a dose constraint. It may be, for example, that some groups of workers may be consistently

older than the average workforce. In this case, because the probability of passing on hereditary effects will be reduced, and because the bulk of the excess risk would occur at very old ages, the annual risk of effects over the remaining life expectancy would be low. Thus if individual doses are already within a nationally set constraint, there would be no need to set an additional more restrictive sector-specific constraint. The employer may, however, choose to set an internal restriction for workers of certain ages.

On the other hand, in paediatric medical exposure, the risk incurred in terms of the additional cancer probability relative to the background rate, in the years following that exposure, is considerably greater than the average in a population and could be deemed excessive, leading to very restrictive constraints.

CONCLUSIONS

There is much work to be done before our ideas on the quantification of radiation detriment can be fully refined. The number of attributes of detriment can proliferate almost indefinitely, and it is necessary to develop clear procedures to decide which are sufficiently useful for their inclusion in radiological protection quantities or as other inputs to decisions. Furthermore, yardsticks against which single or aggregated attributes can be assessed are of prime import.

Not long ago some of these ideas would have seemed too complex as would the number of weighted aspects of detriment included in the ICRP formulation of Effective Dose. However, we must recognise that the real world is complex and ICRP have shown that detriment is not only a more satisfactory measure of the health impact of radiation exposure, but it can be useful and practical. The challenge is to build on this during the next few years.

REFERENCES

1. ICRP. 1990 Recommendations of the International Commission on Radiological Protection. ICRP Publication 60. *Annals of the ICRP* 21, Nos 1-3 (1991)
2. ICRP. Recommendations of the International Commission on Radiological Protection. ICRP Publication 26. *Annals of the ICRP* 1, No 3 (1977)
3. ICRP. Cost-benefit analysis in the optimisation of radiation protection. ICRP Publication 37. *Annals of the ICRP* 10 No. 2/3 (1983).
4. Robb, J D. Valuing radiation detriment for optimisation purposes. *Rad. Prot. Bull.* No 110 (1990)
5. Webb, G A M. Quantification of radiation detriment. *J. Radiol. Prot.* 11, No 3, 163 (1991)
6. Stather, J W, Muirhead, C R, Edwards, A A, Harrison, J D, Lloyd, D C and Wood, N R. Health effects models developed from the 1988 UNSCEAR report. Chilton, NRPB-R226 (1988)
7. Royal Society Study Group. Risk Assessment. London, Royal Society (1983)
8. Health and Safety Executive. The tolerability of risk from nuclear power stations. London, HMSO (1988)

**THE REVISED INTERNATIONAL COMMISSION ON RADIOLOGICAL
PROTECTION (ICRP) DOSIMETRIC MODEL FOR THE HUMAN RESPIRATORY
TRACT**

William J Bair
Pacific Northwest Laboratory
Richland, Washington USA

ABSTRACT

A task group has revised the model of the respiratory tract recommended by the ICRP for use in radiation protection dosimetry¹. The revised model can be used to project respiratory tract doses for workers and members of the public from airborne radionuclides and to assess past exposures. Doses calculated for specific extrathoracic and thoracic tissues can be adjusted to account for differences in radiosensitivity and summed to yield two values of dose for the respiratory tract that are applicable to the ICRP tissue weighted dosimetry system.

INTRODUCTION

The dosimetric model currently used by the ICRP¹ to estimate doses from inhaled radioactive particles was published in 1966². During the past 25 years, research has yielded new knowledge relevant to modeling the intake, deposition, and clearance of inhaled particles and gases. Also, the needs of the ICRP have expanded well beyond those that can be addressed by the current model. This led to an ICRP Task Group* being asked to develop a revised model.

FEATURES OF MODEL

The model is based on the premise that large differences in radiation sensitivity of respiratory tract tissues and the doses they receive from inhaled radioactive particles and gases argue for calculating doses to specific tissues. The current model^{1,2} leads to calculation of doses averaged over the mass of blood-filled lungs.

Parameters needed to calculate doses are assigned values for the reference worker and members of the public. However, values relevant to individuals and to specific exposure situations can be used in the model. Guidance is provided for adjusting the model to account for the possible influence of smoking, respiratory tract diseases, and exposure to airborne toxic substances.

The model is useful for assessment of doses from inhaled radioactive particles and gases as well as for calculating limits on intakes. Tissue average doses calculated for defined regions of the respiratory tract can be adjusted to account for radiation sensitivity differences to yield a single value for the extrathoracic and another value for the thoracic region.

*Members are: M Bailey, FT Cross, RG Cuddihy, P Gehr, AC James, JR Johnson, R Masse, M Roy, W Stahlhofen and WJ Bair, Chairman

These two values of dose are applicable to the ICRP tissue weighted dosimetry system for calculating effective dose.

MORPHOMETRIC MODEL

For purposes of modeling, the respiratory tract is represented by five regions identified on the basis of their respiratory function, cytology, and what is known or can be measured with reasonable confidence about the deposition and clearance of inhaled particles and gases. The two extrathoracic regions are the anterior nasal passages (ET_1) and the posterior nasal and oral passages including the mouth, larynx, and pharynx (ET_2) with associated lymphatics (LN_{ET}). In the thorax are the bronchial (BB), bronchiolar (bb), and alveolar-interstitial (AI) regions with associated lymphatics (LN_{TH}).

For calculating radiation doses, the cytology and histology, as well as morphometric structures, are modeled for each region. Reference values for dimensions important for dose calculations are specified.

DEPOSITION

In modeling the deposition of airborne particles, inhalability and each region of the respiratory tract are represented by a series of equivalent particle filters. The extrathoracic tissues are represented by two filters, one for inhalation and the other for exhalation. The deposition efficiency of each region of the respiratory tract is evaluated by considering particle deposition by aerodynamic and thermodynamic processes, acting competitively. It is assumed that the reference worker is a nose breather, shifting to 50% mouth breathing at respiratory rates greater than about $2.1 \text{ m}^3\text{h}^{-1}$.

To model deposition in the extrathoracic airways, an empirical approach based directly on experimental data was used. To evaluate regional deposition, a theoretical model of particle deposition and gas transport was weighted empirically to fit the mean of experimental data.

CLEARANCE OF INHALED MATERIALS

The model describes three clearance pathways (Figure 1). Material deposited in the ET_1 region is removed by extrinsic processes, such as nose blowing. For the other regions, clearance is competitive between particle transport processes (such as macrophage uptake and ciliary action to the G.I. tract and to lymph nodes) and absorption into blood. The rate of clearance by each process is a time-varying factor of the residual amount. It is assumed that the rates of clearance by particle transport are the same for all materials. Rates were derived from studies with human subjects.

Absorption into blood is a two-stage process: dissociation of the particles into material that can be absorbed into the blood (dissolution) and absorption into blood of inhaled soluble

material and of material dissolved from particles. Absorption is material-specific and is assumed to act in all regions except region ET₁. The model can use observed absorption rates of compounds for which reliable human or experimental animal data exist. In the absence of such data, absorption rates are specified as "fast" F, "moderate" M, or "slow" S, based on the current D, W, and Y classification system of the ICRP². The default values, expressed as half-times, are: 10 min for F materials, which are rapidly absorbed into blood; 3 d for 50% and 100 d for the remaining 50% of M materials with intermediate rates of absorption; and 7000 d for S materials, which are very insoluble.

DOSIMETRIC MODEL FOR GASES AND VAPORS

The model addresses three classes of gases and vapors. The first, SR-0, insoluble and nonreactive, results in exposure of all airways. The second, SR-1, either soluble or reactive, results in exposure of all airways. However, these gases and vapors can also be absorbed into tissues and blood throughout all airways. The third class, SR-2, consists of highly soluble and reactive gases and vapors that are completely absorbed by tissues and blood in the extrathoracic tissues.

CALCULATION OF TISSUE AVERAGE DOSES

Doses are calculated by the ICRP system in which energy absorbed is averaged over the mass of the target tissues in each region. These doses can be adjusted to account for differences in radiation sensitivity and summed separately for the extrathoracic and thoracic regions. These two adjusted doses can be used with the ICRP tissue weighting factors in calculations of effective dose³.

It is proposed that the doses calculated for each region be adjusted on the basis of the best estimates of their relative sensitivity to radiation-induced cancer. These estimates and the factors used to adjust regional doses cannot be very precise because of the scarcity of information and of unknowns such as the influence of smoking and exposure to air pollutants. However, the impact on the summed doses is not large.

SUMMARY

The new respiratory tract model provides for calculating average doses to specific tissues rather than to the total lung mass. The model is more complex than the current model because it describes deposition of inhaled radioactive material in and clearance from several tissues and regions of the respiratory tract and is applicable to the worldwide population of both workers and the public.

REFERENCES

1. International Commission on Radiological Protection. 1979, Limits for Intakes of Radionuclides by Workers, publ. 30, Annals of the ICRP, vol. 2, no. 3/4, Pergamon Press, Oxford-New York.
2. Morrow, P.E. et al., 1966, Deposition and Retention Models for Internal Dosimetry of the Human Respiratory Tract, Health Phys., 12, 173-207.
3. International Commission on Radiological Protection. 1991, 1990 Recommendations of the International Commission on Radiological Protection, publ. 60, Annals of the ICRP, vol. 21, no. 1-3, Pergamon Press, Oxford-New York.

ACKNOWLEDGMENT

PREPARED FOR THE U.S. DEPARTMENT OF ENERGY UNDER CONTRACT DE-AC06-76RLO 1830

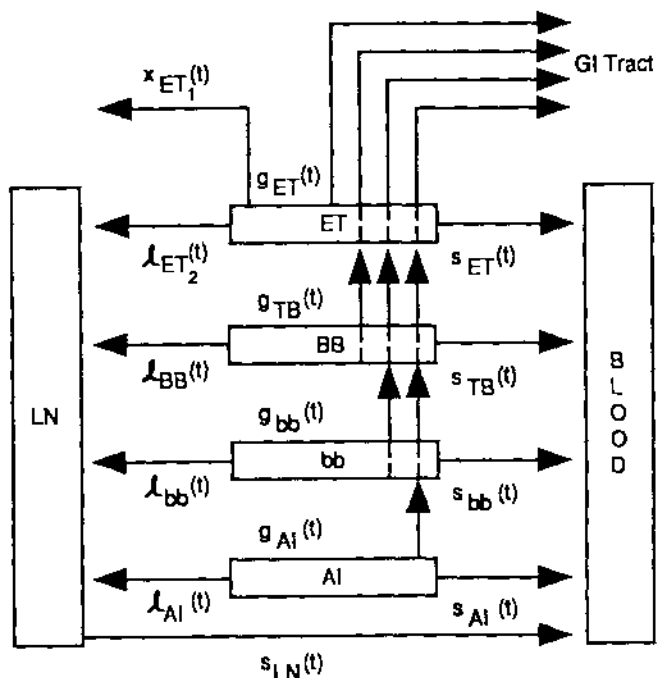

Figure 1. Clearance Model. Symbols indicate fractional rates of clearance, at time t , after an acute intake, by each route from each region.

IMPROVEMENTS IN RADIATION PROTECTION USING A PROPRIETARY AUDIT SYSTEM

K W Bowker & J M Stevenson

University of Oxford Safety Office,
Oxford, United Kingdom

ABSTRACT

The paper describes the International Safety Rating System (ISRS) and its application and suitability to auditing an organisation's radiation protection arrangements. Particularly pertinent elements in the audit system are identified and briefly described. The benefits derived from the practical application of the audit are identified.

INTRODUCTION

All health and safety management systems need to be tested in order to evaluate whether they are suitable, complete and working satisfactorily. Auditing is a tried and tested way of carrying out this process. Following a study of the proprietary audit systems available and of current audit methodology, the authors introduced ISRS at Oxford University during 1990. Departments or units within the University are audited individually. The system has been applied to all aspects of safety, including radiation protection. ISRS is the most comprehensive safety management audit system in the world. The audit provides for a methodical, detailed analysis and evaluation of each aspect of an employer's policy, organisation and arrangements for safety. The systems in place at the unit being audited are compared for completeness against the model safety system of ISRS. Auditors using ISRS are required to undergo a course of training which has been organised by or under the auspices of the system's authors, the International Loss Control Institute. They are also required to pass an examination at the end of the course.

ISRS identifies the likelihood of accidents occurring before they become either property damaging incidents or an accident involving people and this is particularly important for activities with both a potential for high cost and a public perception of high risk.

THE AUDIT SYSTEM

The audit measures up to twenty elements of a model safety management system (see table). It is a scheme of precise questioning with built-in verification techniques. A full audit consists of asking all questions in all elements. With a total of six hundred and fifteen questions being involved. However, the system is normally applied in a progressive manner through ten stages. At the lowest level (known as Standard One), only a total of eighty-six questions in a total of thirteen elements are asked. Points are awarded according to the verified answers given. In order to move to the next level in the system, a minimum points total must be achieved. In addition, a physical inspection of a representative sample of the unit being audited is carried out and scored again with a minimum score being necessary to progress. It is at Standard One that ISRS was introduced at Oxford University.

TABLE

THE TWENTY ELEMENTS OF ISRS

1. Leadership and Administration.
2. Management Training.*
3. Planned Inspections.
4. Task Analysis and Procedures.*
5. Accident Investigation.
6. Task Observation.*
7. Emergency Preparedness.
8. Organisational Rules.
9. Analysis of Accidents and Incidents.*
10. Training for Employees.
11. Personal Protective Equipment.
12. Health Control.
13. Programme Evaluation Systems.*
14. Engineering Controls.
15. Personal Communications.
16. Group Meetings.
17. General Promotion.*
18. Hiring and Placement.
19. Purchasing Controls.
20. Off-the-job Safety.

* Not used at the lowest level of auditing.

Following the questioning, verification, physical inspection and scoring phases of the audit, the auditors write their report on each of the elements. When the head of the unit and his team have had the time to digest the report, a full review meeting, involving the auditors, the head of the unit and various members of the safety management team, is held to discuss the audit's findings.

In addition to applying ISRS in the conventional manner, managers of high-risk activities often wish to ensure that certain elements of their management system are at a more advanced level than Standard One. Radiation protection arrangements are a prime example where the activity warrants the audit to be carried out at an advanced level. In these cases, they may ask for all questions in selective elements to be addressed. This enables auditors to determine the level a unit has achieved in a particular key element and to identify matters for development. The authors regard six of the twenty elements to be particularly relevant to radiation protection arrangements. These are task analysis, task observation, emergency preparedness, personal protection equipment (PPE), engineering control policy and planned inspections.

KEY ELEMENTS FOR RADIATION PROTECTION

Task analysis means that the components of the task or work are systematically examined in order to establish safe and effective procedures.

Task observation is a structured process by which there are checks on employees performing critical tasks (ie: those which have produced and/or possess the potential to produce a major loss to people, property or process, when not performed properly). Performance is expected to be in accordance with approved procedures.

Organisations need comprehensive emergency plans and this element measures the validity and comprehensiveness of emergency planning and questions the arrangements in place against the system standard.

Sound engineering and the proper maintenance of plant and equipment help to minimise exposure to harmful agents, such as ionising radiation. If engineering controls alone cannot provide sufficient protection, then the use of PPE is often necessary. The requirements for PPE need to be identified and thereafter, its proper selection, use and maintenance is essential. The questions in this element of the audit test that these arrangements are suitable and satisfactory.

Engineering control policy requires proper design installation and modification of both process, plant and equipment. In addition, before commissioning or recommissioning takes place, proper review procedures are required. Engineering policy is also meant to define responsibilities and questions in the element determine whether these matters have been addressed satisfactorily.

The purpose of planned inspections is to identify hazardous situations and organise remedial work before any losses can occur. There should be equipment inspections and general inspections to detect deviations from the required standards. Also necessary are inspections of critical parts and items and pre-use inspections of equipment. All inspections, regardless of title, should be planned at regular intervals and the inspections themselves should be monitored and accompanied by an effective written follow-up procedure. This elements' questions, therefore, are concerned with the effectiveness of inspections in the department, including those concerning preventative maintenance.

CONCLUSIONS

Auditing of University departments using ISRS is continuing at Oxford and is bringing about major improvements in safety. The work has demonstrated that it is possible to successfully audit particular management systems, ie: radiation protection arrangements within the overall system and the authors believe believe it is practical to make the necessary changes to ISRS scoring. In practice, auditing is proving to be an excellent aid to determining the areas requiring additional resources and in the prioritisation of remedial actions. Auditing emphasises the concept that safety must be managed. It has also become clear that auditing should always be set against a background of regular, thorough, physical inspections and other monitoring exercises.

The authors recommend that the use of a formalised audit system should be promoted as a method of significantly improving radiation safety arrangements.

OPTIMIZATION (ALARA) OF RADIATION PROTECTION
AT DEPARTMENT OF ENERGY FACILITIES

A. A. Weadock and C. Rick Jones

Office of Health Physics and Industrial Hygiene
U.S. Department of Energy
Washington, D.C. 20585

ABSTRACT

Maintaining worker and public exposures As Low As Reasonably Achievable (ALARA) is a key objective of the Department of Energy (DOE). Responsibility for occupational ALARA program policy and guidance resides within the DOE Office of Health. Current Office of Health initiatives related to ALARA include the development of additional regulatory guidance related to ALARA program implementation at DOE contractor facilities, the review of ALARA program status at various facilities and the production of technical reports summarizing this status, and the support of various mechanisms to improve communication among the DOE ALARA community. The Office of Health also monitors revisions to radiogenic risk estimates and radiation protection recommendations to evaluate adequacy of current DOE limits and impacts of potentially revised limits.

REGULATORY INITIATIVES

Current occupational ALARA program requirements applicable to DOE contractor facilities are identified in DOE Order 5480.11, "Radiation Protection for Occupational Workers." Specific requirements include the need for formal ALARA plans and programs, the use of optimization methodology in radiological design, the provision for worker training on ALARA techniques, routine audits of ALARA program implementation, and maintenance of ALARA records. DOE Order 5480.11 and its inclusive ALARA program requirements are currently being codified into a draft rule (10 CFR 835) for publication in the U.S. Code of Federal Regulations (CFR) in November 1991.

To supplement basic regulatory requirements contained in Order 5480.11 and the draft rule 10 CFR 835, the Office of Health is developing an ALARA Implementation Guide (IG), scheduled for initial distribution in November 1991. The ALARA IG will identify those basic program elements and functions necessary for an acceptable ALARA program. In recognition of the broad diversity of DOE contractor facilities and missions, the approach taken in the IG is to identify the specific programmatic functions that should be in place, and include a stipulation that the formality and extent of their implementation should be commensurate with the hazard and the potential exposure savings.

The Department has also published a broad scope manual (PNL-6577) which provides extensive guidance on ALARA program implementation, including program enhancements and good practices. Once finalized, the ALARA IG will serve as a intermediary or bridge between the basic requirements in Order 5480.11 and the good practice guidance of PNL-6577.

As a corollary to its responsibilities for policy and guidance development, the Office of Health also monitors and evaluates revisions to radiogenic risk estimates and basic radiation protection recommendations to assess the adequacy of existing DOE occupational worker radiation exposure limits in controlling exposure and the impact of potential revisions to the occupational exposure limits. During 1990, DOE conducted a formal review of the potential impacts of the National Academy of Science Biological Effects of Ionizing Radiation (BEIR V) Report.

As part of this review, the Office of Health evaluated current exposure trends and also identified projected increases in facility costs, staffing, and collective exposure that would result from implementation of a reduced occupational exposure limit. The review of DOE exposure statistics identified that both collective and individual exposures within DOE have showed significant decreasing trends over the 1979-1989 period, as shown in figure 1. These decreases can be attributed to increasing emphasis on ALARA and, particularly in the last few years, to curtailments on facility operations or shift in facility mission. The DOE study report, published in 1990, concluded there was no immediate need for revision of current DOE occupational exposure limits, but emphasized the importance of ALARA program and dose reduction efforts in optimizing individual and collective exposures.

REVIEW OF PROGRAM STATUS

Utilizing contractor support from the Brookhaven National Laboratory ALARA Center, the Office of Health has initiated various reviews to identify the current status of ALARA program implementation at DOE contractor facilities. During 1989-1990, a survey of ALARA program implementation at 12 major contractor facilities was conducted. The report, to be published in 1991, identifies overall status of ALARA program implementation within DOE; identifies the generic strengths, weaknesses, and areas for improvement; and lists specific dose reduction methods that have been found effective for specific radiological jobs and activities. A supplemental volume to the report includes "good-practice" examples of generic ALARA program documents (i.e., policy statements, Radiation Work Permit (RWP) forms, pre-job planning checklists, ALARA lesson plans) that can be easily modified and utilized by specific facilities in their ALARA programs.

A second such study, focusing on high-dose workers and work activities and radiological design criteria, was initiated in 1991.

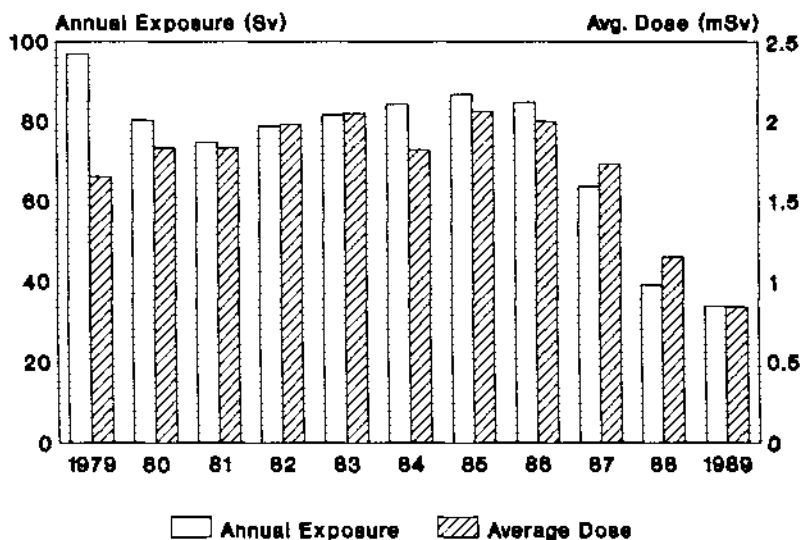

Figure 1- DOE Collective and Average Individual Exposures for 1979-1989 (average exposures shown for personnel with measurable exposure).

IMPROVING COMMUNICATIONS

The Office of Health also supports several activities designed to improve overall communication among the members of DOE and DOE contractor ALARA community. Towards this end, the Office of Health has contracted with the BNL ALARA Center to provide their ALARA technical expertise and information sharing capabilities to the DOE community. Specific task or initiatives undertaken in this area include:

- Publication of a continuing series of ALARA bibliographies containing references particularly applicable to DOE and its contractors.
- Development of a DOE ALARA Radiological Contacts List, which is frequently updated and distributed within the DOE community to promote communications.

- Conduct of conference sessions and workshops specific to ALARA programs. Several sessions during the August, 1991 DOE Radiation Protection Conference were devoted to DOE ALARA programs. A two-day DOE ALARA Workshop is planned for Spring, 1992.

CONCLUSIONS

Efforts in ALARA program implementation and dose reduction have resulted in significantly decreasing trends in collective and individual exposure at DOE contractor facilities over the past several years. Current Office of Health initiatives related to the development of ALARA policy and guidance, review of ALARA program implementation, and the promotion of communication and exchange of ideas within the DOE community reflect a continued emphasis on dose reduction and should prove effective in reducing DOE exposures to ALARA levels.

REFERENCES

1. Department of Energy Order 5480.11 (12/21/88). Radiation Protection for Occupational Workers.
2. Pacific Northwest Laboratory (1988). DOE Health Physics Manual of Good Practices for Reducing Radiation Exposure to Levels that are As Low As Reasonably Achievable (ALARA). PNL-6577, Richland, WA.
3. U.S. National Academy of Sciences (1989). Report by the Committee on the Biological Effects of Ionizing Radiations (BEIR V). National Academy of Sciences/National Research Council, Washington, D.C.
4. Department of Energy (1990). Final Report to the Secretary of Energy: Implications of the BEIR V Report to the Department of Energy. DOE/EH-0158T, Washington, D.C.
5. Department of Energy (1990). Twenty-first Annual Report: Radiation Exposures for DOE and DOE Contractor Employees - 1988. DOE/EH-0171P, Washington, D.C.

ANGULAR DEPENDENCE OF ORGAN DOSES AND EFFECTIVE DOSE
FOR EXTERNAL PHOTON IRRADIATION

Y. Yamaguchi and M. Yoshizawa

Japan Atomic Energy Research Institute,
Tokai-mura, Naka-gun, Ibaraki-ken, 319-11 Japan

ABSTRACT

Based on the new ICRP recommendations, the equivalent doses in organs and tissues and the effective dose were calculated using the Monte Carlo method for monoenergetic photons incident at each of 86 different angles. The results which were obtained for incident photon energies of 45, 90 and 1250 keV are demonstrated and the angular dependence of these dosimetric quantities is also discussed.

INTRODUCTION

The ICRP has, in its new basic recommendations¹⁾, defined a new dosimetric quantity, the equivalent dose H_R , for radiation protection purposes with the newly introduced radiation weighting factor w_R . The ICRP has also amended the tissue weighting factor w_T and the definition of the remainder organs or tissues, which should affect directly the assessment of the effective dose E , previously called the effective dose equivalent H_E ²⁾. Since these new dosimetric quantities are expected to be different from the former ones, it is quite important to estimate them based on the method newly recommended. In addition, it is also worthwhile to make clear their characteristics to ensure the reasonable dose estimation in actual radiation protection practices. Since the quantity E cannot be measured, computer simulation is considered to be the best solution to estimate E at this moment. In the present work, the values of H_R in organs and tissues and E were calculated using the Monte Carlo method for external photon irradiations, and the results were analyzed to clarify their dependence on the radiation incident angle.

METHOD

The equivalent doses H_R for 61 different organs and tissues were calculated for external photons using a revised version of the DEEP code³⁾ in which the MORSE-CG code⁴⁾ is incorporated to calculate the radiation transport. Used was a MIRD-5 type phantom^{3),5)}, defined by mathematical formulae and with limited number of human media with different elemental compositions and densities: soft, lung and skeletal tissues. The photon cross sections were taken from the DLC-15 library⁶⁾ and the photon energy from 5 to 12000 keV was collapsed into 24 groups. The kerma approximation was employed for dose calculation, which is considered to give a good approximation for photons of energies less than several MeV. While three kinds of human media were used in the photon transport calculation, the red and yellow bone

marrow tissues were added to them in the dose calculation. One of the biggest problems in calculating E with the MIRD-type phantoms is that they do not have the oesophagus. Hence the phantom was modified to have the oesophagus which was represented by an elliptical normal tube descending along the spine from the neck to around the diaphragm and an inclined tube attaining to the upper part of the stomach. The effective dose E was evaluated as a sum of weighted doses, $\sum w_T H_T$, with a set of the values of w_T specified in the new recommendations. The value of the w_T of 0.05 was allocated to the dose averaged over organs and tissues specified as the remainder by the ICRP.

The dose calculations were performed for monoenergetic photons incident in parallel beams at each of 86 different angles, defined at the spherical lattice points including both poles. Three photon energies were selected: 45, 90 and 1250 keV. All the calculated results were given as the values per unit absorbed dose to air in free air.

RESULTS AND DISCUSSION

From a number of calculated results, some typical examples are shown in this paper. The statistical error (one relative standard deviation) of the results is less than 5% for H_T and less than 3% for E.

The angular dependence of weighted equivalent doses ($w_T H_T$) relative to the horizontal axis of the human body is shown in Figure 1 for the gonads, red bone marrow and breasts for the incidence of 90 keV photons. The equivalent doses for these organs have a symmetric response with respect to the anteroposterior axis, reflecting their symmetric configuration in the human body.

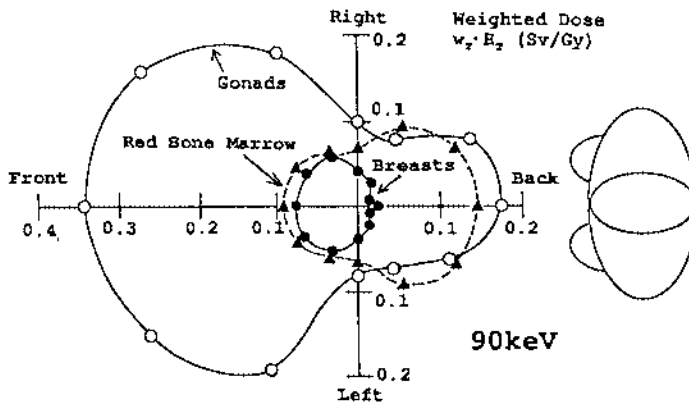

Figure 1. Angular dependence of weighted equivalent doses ($w_T H_T$) per unit absorbed dose to air in free air, relative to the horizontal axis of the human body for the gonads, red bone marrow and breasts. Incident photon energy is 90 keV.

An enhanced response for the photons from the front-half-around angle can be observed for the gonads and breasts. It is quite reasonable considering their location in the body. On the contrary, the red bone marrow has a slightly higher response for the back-half-around angle and it can be explained by its high content in the spine and pelvis. From observation of angular dependence of $w_R H_T$ in organs for all the 86 incident angles, it can be concluded that the gonads provide a dominant component of E , especially for the photons incident from the forward 2π solid angle.

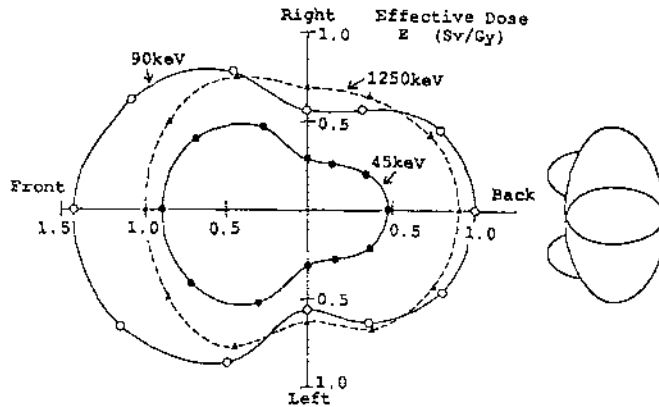

Figure 2. Angular dependence of the effective dose per unit absorbed dose to air in free air, relative to the horizontal axis of the human body for the photons of 45, 90 and 1250 keV.

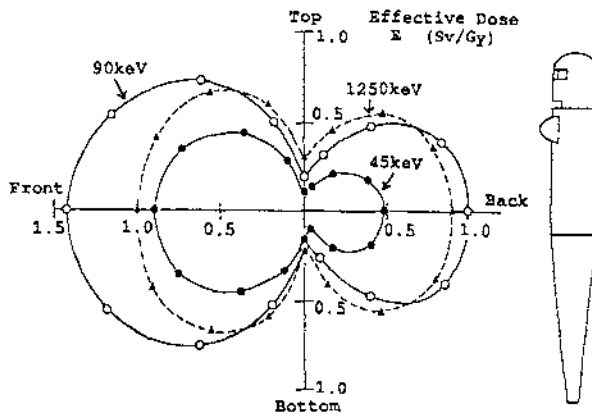

Figure 3. Angular dependence of the effective dose per unit absorbed dose to air in free air, relative to the vertical axis of the human body for the photons of 45, 90 and 1250 keV.

Figures 2 and 3 shows the angular dependence of E relative to the horizontal axis and vertical axis of the body, respectively, for the photons of 45, 90 and 1250 keV. In Figure 2, a symmetric response of E can be observed with respect to the anteroposterior axis in spite of asymmetric configuration of some organs such as stomach and liver. In Figure 3, an extremely depressed response of E can be seen for the photons incident from the top and bottom. This is because the principal organs are located at around the center of the body and they are shielded by the human tissue against the photons incident from such angles. Observing these two figures, it can be said that while the angular response of E for low energy photons, at 45 keV, appears enhanced in the forward 2π solid angle, the response becomes more and more isotropic with increasing the photon energy. It can be pointed out as an important characteristics of E that the response of E appears most enhanced for the photons incident at the just front angle for external photon exposure. It suggests that dosimeters worn at the surface of the front trunk gives the best indication in the general situation of personal monitoring. Finally, Figures 2 and 3 suggest also a need of special measures to monitor the dose for the photons incident from the top and bottom.

CONCLUSIONS

The equivalent doses H_T in organs and tissues and the effective dose E were calculated using the Monte Carlo method for external photon irradiations. The angular dependence of these dosimetric quantities was analyzed with the calculated results. A significant angular dependence is observed in both H_T and E. An interesting characteristics is that E appears most enhanced, for the photons incident at the just front angle.

REFERENCES

- 1) ICRP: ICRP Publication 60, Annals of the ICRP, 21, 1-3, Pergamon Press, Oxford (1991).
- 2) ICRP: ICRP Publication 26, Annals of the ICRP, 1, 3, Pergamon Press, Oxford (1977).
- 3) Yamaguchi Y.: JAERI-M 90-235 (1991).
- 4) Emmet M.B.: ORNL-4972 (1975).
- 5) Cristy M.: NUREG/CR-1159 (1980).
- 6) Storm E. and Israel H.: Nuclear Data Tables, A7 (1970).

**ANALYSE COMPARATIVE DES DIFFÉRENTS SYSTEMES
JURIDIQUES EN MATIERE DE RADIOPROTECTION**

**MM. Delpirou - Fiquet
Electricité de France - Service Juridique - Paris - France**

L'objet de cette étude est de présenter sous forme comparative les systèmes juridiques de radioprotection mis en oeuvre par la communauté européenne et ceux de trois principaux Etats membres ayant recours à la production d'électricité d'origine nucléaire : Allemagne, Royaume-Uni et France.

L'analyse portera sur les principes généraux de radioprotection et plus précisément sur les trois domaines qui constituent le fondement des normes de base visées par le traité EURATOM :

- les doses maxima admissibles;**
- les expositions et contaminations maxima admissibles;**
- les principes fondamentaux de surveillance médicale des travailleurs.**

Pour chacun de ces domaines, seront comparées sur la base de la réglementation communautaire, les normes nationales des trois Etats considérés, tant du point de vue "quantitatif" (montant des doses...) que "qualitatif" (exposé des motifs ayant présidé à l'instauration de législation nationale, champ d'application couvert par les textes, risques particuliers pris en considération compte-tenu de la nature des installations, mise à jour de la réglementation en fonction des progrès techniques réalisés...).

La communication permettra de souligner les éventuelles différences quant à l'approche de cet impératif de sécurité, l'état de comptabilité des droits nationaux avec les règles européennes et mesurera en quoi l'institution du traité de la Communauté européenne de l'énergie atomique a contribué ou non à unifier les réglementations nationales dans ce secteur particulier.

THE REVIEW OF SAFETY CASES WITHIN BNFL

J P Shepherd
A H Fishwick

British Nuclear Fuels plc
United Kingdom

ABSTRACT

The British regulatory process requires BNFL to make safety submissions for all major activities, ie design/construction, commissioning, operation, modification and decommissioning. As part of the regulatory requirement, an independent review of the safety is necessary. This paper describes how the review takes place within BNFL.

INTRODUCTION

BNFL operate processes which cover the whole of the nuclear fuel cycle. Fuel manufacture takes place at Springfields near Preston, enrichment at Capenhurst near Chester, whilst the reprocessing operation is conducted at Sellafield in West Cumbria. Additionally, BNFL operate the original Magnox power reactors at Sellafield, and a similar installation at Chapelcross, Scotland.

The British regulatory process requires the licensee (BNFL) to make detailed safety submissions for all major activities, ie design/construction, commissioning, operation, modification, and decommissioning. The regulatory body issues consents as appropriate when it is satisfied with the safety submissions.

The preparation of safety submissions is the responsibility of the various operating divisions within BNFL. These submissions are extensive, and generally include probabilistic analyses as well as deterministic demonstrations.

As part of the regulatory requirement a second opinion, or Peer Review is required by the Regulator - for all Safety Cases. The review process is the responsibility of an independent group which is part of the Central Health and Safety Directorate, and which has no line management ties to Operating Divisions. It is the purpose of this paper to describe how this activity functions within BNFL.

METHODOLOGY

Safety cases are categorised according to their safety significance and the depth of their review depends on this categorisation. The categorisation is done in advance of the main safety case preparation. The first task of the reviewer is to agree or disagree with the categorisation which has been made. The first few steps in the flowchart in Figure 1 shows this process.

In a safety categorisation system which has categories 1, 2, 3 and 4 (with 1 having the highest safety significance), the review exercise is structured as indicated in the following table.

Category	Summary of Review Exercise
1 2 3 4	Categorisation of safety case check
1 2 3	Audit <ul style="list-style-type: none"> - procedures - methods
1 2	Completeness <ul style="list-style-type: none"> - plant/modification itself - other interacting plant
1 2	Inventory library check
1 2	Logic and methodology <ul style="list-style-type: none"> calculations - risk estimates - check (sample)
1	Logic and Methodology <ul style="list-style-type: none"> calculations - risk estimates - check (representative selection) - first principles (sample)
1	HAZOP <ul style="list-style-type: none"> - sample

* Only if the reviewer judges it to be warranted.

The degree of attention given to separate parts of the safety case should be commensurate with the reviewer's opinion of the risks involved. The review could range from simply a check of the safety case categorisation to a fundamental evaluation of the safety case depending on the safety significance and the reviewer's initial assessment of the safety case.

As can be seen from the table, the methodology involves an "inventory library". This makes use of a library of historical data compiled from safety analyses of a range of plant such that a given safety analysis may often be compared against a similar previous one to see whether or not the result is of the right order. The other steps in the table are self explanatory.

The reviewers only review completed safety cases, ie cases which are ready for submission to a safety committee. The result of the review will be one of three conclusions.

- case satisfactory
- case generally satisfactory but further work required
- case unsatisfactory

This result and its associated report are routed to the project sponsor who is usually a senior manager in the operating division. The interaction between the review, the safety committee and the regulator, is shown in Figure 1.

STAFFING

The review team consists of a small nucleus of BNFL staff with each principal reviewer being responsible for a BNFL division or divisions. The principal reviewer then calls on the assistance of experienced specialists to examine particular aspects of the safety case in more detail as appropriate. These specialists may or may not be BNFL employees, but they must be independent of the authors of the safety case under consideration.

CONCLUSION

The independent review of safety cases is established within BNFL and is seen as an important step in the process of self regulation.

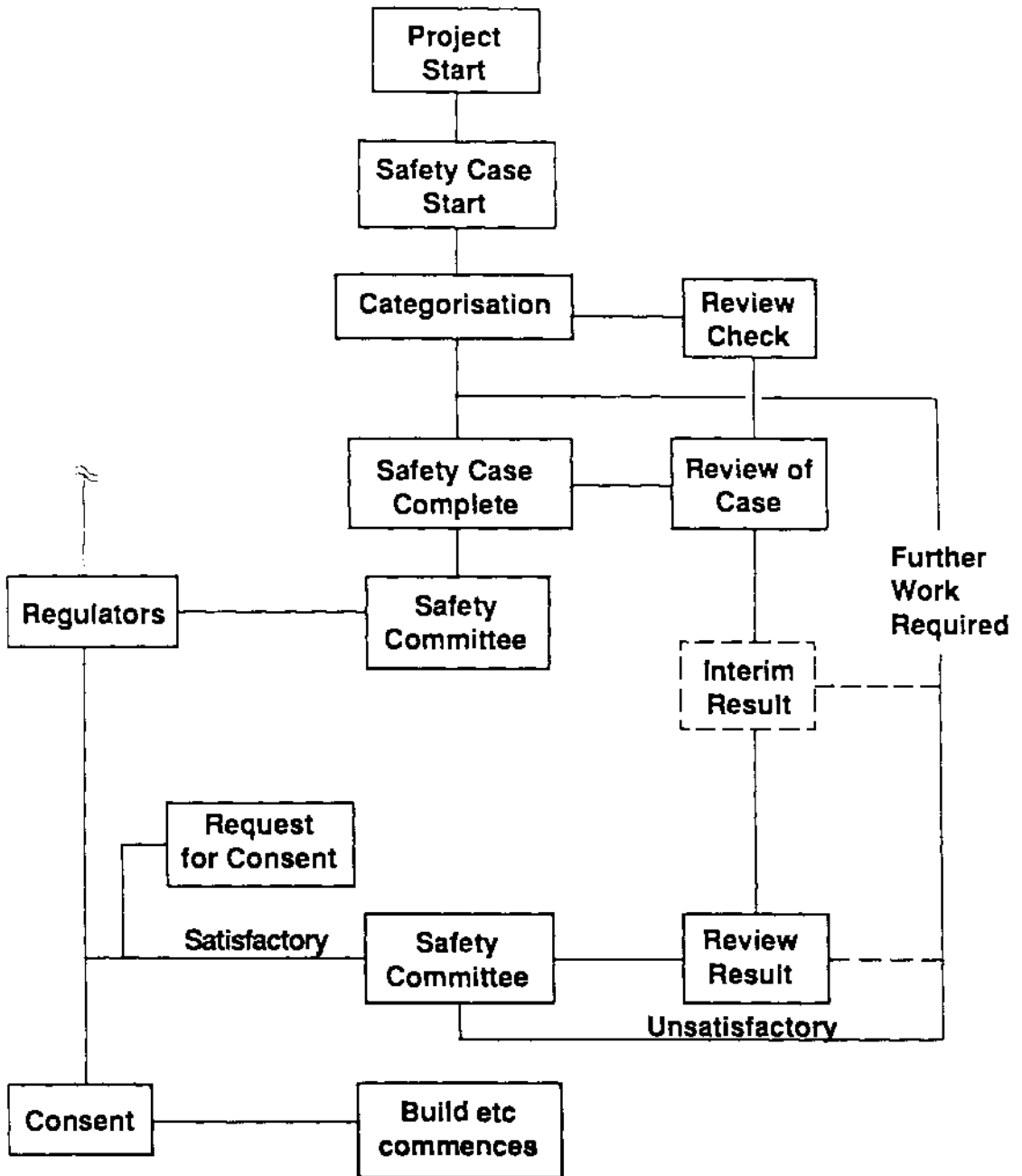

Figure 1 - Project Flowchart Showing Review Function

The U.S. Department of Energy Laboratory Accreditation Program
for Testing the Performance of Extremity Dosimetry Systems:
A Summary of the Program Status

F.M. Cummings, R.D. Carlson, T.F. Gesell, DOE/Idaho Falls
and
R.M. Loesch, DOE/Office of Health

Introduction

In 1986, The U.S. Department of Energy (DOE) implemented a program to test the performance of its personnel whole-body dosimetry systems. This program was the DOE Laboratory Accreditation Program (DOELAP). The program parallels the performance testing program specified in the American National Standard for Dosimetry - Personnel Dosimetry Performance - Criteria for Testing (ANSI N13.11-1983), but also addresses the additional dosimetry needs of DOE facilities. As an extension of the whole-body performance testing program, the DOE is now developing a program to test the performance of personnel extremity dosimetry systems. The draft DOE standard for testing extremity dosimetry systems is much less complex than the whole-body dosimetry standard and reflects the limitations imposed on extremity dosimetry by dosimeter design and irradiation geometry. A pilot performance test session has been conducted to evaluate the proposed performance testing standard.

DOE Laboratory Accreditation

The process for gaining accreditation of a dosimetry system follows. The laboratory seeking accreditation completes an application form that identifies the irradiation categories in which testing is required and that describes the dosimetry system being tested. This application is submitted through the local DOE Field Office to the Performance Evaluation Program Administrator. At the direction of the performance testing laboratory, the applicant sends an appropriate number of dosimeters for testing. The testing laboratory irradiates the dosimeters and returns them to the applicant. This process of sending, irradiating and returning the dosimeters is repeated two more times. The duration of the dosimeter testing phase is approximately five months. The applicant reports the dosimeter results to the testing laboratory where the results are evaluated using the performance criteria defined in the testing standard. If a dosimetry system does not meet the specified performance criteria, the applicant must repeat all or a portion of the performance test.

When the performance test criteria have been successfully met, the administrator assigns two assessors from other laboratories to evaluate the applicant's ability to conduct a credible personnel dosimetry program. The onsite assessment includes evaluation of quality assurance, documentation of the system, personnel training, personnel competency, facilities and equipment, equipment maintenance and calibration and recordkeeping. Using the results of the performance test and the onsite assessment, the administrator collects a file of supporting information which is used by the DOELAP Oversight Board for recommending accreditation actions to the DOELAP Program Administrator at DOE Headquarters. If the applicant feels an action is incorrect, the applicant and DOE Field Office may petition a

Board of Appeals.

To maintain accreditation, DOE laboratories must pass performance testing and onsite assessment every two years. A laboratory which does not pass all of the performance testing may be granted conditional accreditation for a subset of the testing requirements specified in the application. If a laboratory is not fully accredited it must submit and implement a remedial action plan to correct the deficiencies prior to achieving full accreditation.

Testing Categories

The draft extremity dosimetry standard applies to dosimetry performed for health protection under controlled (protection level) and uncontrolled (accident level) conditions. Tests for accident dosimetry are approximately represented by a high dose category. Performance studies for angular dependence and lower limit of detectability are required one time only for each dosimeter type submitted for evaluation.

The testing categories are summarized in Table 1. With the exception of the uranium slab source, all of the irradiation sources in the standard are consistent with specifications in ISO documents. With the exception of neutron irradiations, the reference depth for the specification of dose or dose equivalent to the extremities is 7 mg/cm². The testing criteria are:

$$|B| + S - |E| \leq L$$

- where
- B is the average bias of dosimeters in a particular category or subcategory,
 - S is the standard deviation of the measurements for a particular category or subcategory,
 - E is the estimation of the fractional uncertainty in the delivered dose or dose equivalent rate and
 - L is the tolerance level (L = 0.3 for category I and 0.5 for categories II through IV)

Performance tests for neutron dosimetry are included in the draft standard because neutron exposures are currently measured and reported by DOE and DOE contractor facilities where the extremities of workers are exposed to significant dose equivalents from neutron fields. It is recognized that numerous complexities exist in assigning a dose to the extremities from neutron radiation. For purposes of dosimeter performance evaluation, the testing standard uses the existing neutron fluence to dose equivalent conversion factors specified in International Standard ISO-8529 for the whole body. While there are significant technical inadequacies with this approach, including the depth for dose evaluation and the use of quality factors, the approach is consistent with practices used at this time to record dose equivalent. A study by DOE to determine more meaningful and technically based quantities for extremities is planned. As that information becomes available, the standard will be revised.

Categories comprised of mixtures of sources (e.g., low and high energy photons or beta particles and high energy photons) have not been included at this time. In general, the extremity dosimeters that are currently in

use cannot discriminate between radiation types and energies unless they are multi-element dosimeters. In addition, extremity dosimeters are typically used to monitor specific exposure situations where the source of exposure is known or the response of the dosimeter has been previously characterized.

Table 1. Irradiation Categories

<u>Test Category</u>	<u>Energy</u>	<u>Test Range</u>
IA. Photons, Accident, General NIST M150 X ray ¹³⁷ Cs	70 keV (Average) 662 keV	0.1 to 5 Gy
IB. Photons, Accident, Special NIST M150 X ray	70 keV (Average)	
IC. Photons, Accident, Special ¹³⁷ Cs	662 keV	
IIA. Low Energy Photons NIST M30 X ray NIST M150 X ray	20 keV (Average) 70 keV (Average)	2.5 to 100 mSv
IIB. High Energy Photons ¹³⁷ Cs	662 keV	2.5 to 100 mSv
IIIA. Beta Particles, General (point geometry) ²⁰⁴ Tl ⁹⁰ Sr/ ⁹⁰ Y	0.76 MeV (Maximum) 2.3 MeV (Maximum)	2.5 to 100 mSv
IIIB. Beta Particles, Special (point geometry) ⁹⁰ Sr/ ⁹⁰ Y	2.3 MeV (Maximum)	2.5 to 100 mSv
IIIC. Beta Particles, Special (point geometry) ²⁰⁴ Tl	0.76 MeV (Maximum)	2.5 to 100 mSv
IIID. Beta Particles, Special (slab geometry) Uranium	2.3 MeV (Maximum)	2.5 to 100 mSv
IVA. Neutron, General ²⁵² Cf (D ₂ O-moderated) ²⁵² Cf (unmoderated)		2.5 to 100 mSv
IVB. Neutron, Special ²⁵² Cf (D ₂ O-moderated)		2.5 to 100 mSv
IVC. Neutron, Special ²⁵² Cf (unmoderated)		2.5 to 100 mSv

Dosimeter Phantoms

Five phantom designs shall be used for extremity dosimeter irradiations: one to represent a lower arm or leg to test wrist or ankle dosimeters for photon and point geometry beta exposures; a second similar phantom for neutron irradiations; a third to represent a finger to test ring or hand dosimeters; a fourth to represent a lower arm or leg to test wrist or ankle dosimeters for uranium slab exposures and a fifth to represent a finger to test ring or hand dosimeters for uranium slab exposures. Originally, the standard specified only three phantoms, but two additional phantoms were required to perform uranium slab irradiations. The arm/leg phantoms used

for photon and beta exposures are right circular cylinders of aluminum with a diameter of 60 mm nested inside a tube of polymethylmethacrylate (PMMA) with an inner diameter of 60 mm and an outer diameter of 73 mm. The length of the aluminum insert and the PMMA tube are both 300 mm. The arm/leg phantom used for neutron irradiations is a right circular cylinder of PMMA with a diameter of 73 mm and a length of 300 mm. The finger phantoms are right circular cylinders of PMMA with a diameter of 19 mm and a length of 300 mm.

The phantoms used for uranium slab exposures incorporate sections of phantoms as specified above, but allow all the dosimeters to be placed on the slab at once and float in such a manner to allow dosimeters of different thickness to be in contact with the slab source simultaneously without being tilted.

The factors for the photon fields which convert exposure to dose equivalent (Sv/R) at 7 mg/cm² have been measured by Roberson, et. al. and incorporate a quality factor of unity. The factors are:

	<u>Arm/Leg Phantom</u>	<u>Finger Phantom</u>
M30 X-Ray Technique	9.9	9.5
M150 X-Ray Technique	11.4	10.1
¹³⁷ Cs Gamma-Ray Source	10.2	9.8

The neutron fluence to dose equivalent conversion factors are for the torso phantom and have been specified in International Standard ISO-8529. Those factors are 9.1×10^{-11} Sv·cm² for the D₂O-moderated ²⁵²Cf source and 3.33×10^{-10} Sv·cm² for the unmoderated ²⁵²Cf source. The factor for the moderated Cf source is further modified to account for the loss of thermal neutrons in the cadmium shield surrounding the D₂O.

Performance Testing Pilot Study

A pilot test session has been conducted to evaluate the proposed performance testing standard. Six DOE laboratories submitted a total of six ring dosimeters and two wrist dosimeters for testing. While not all test sub-categories were included in testing, all sources were included (e.g., testing occurred in category IA, Photons, Accident, General using M150 and ¹³⁷Cs, but not in the special categories IB and IC for which a single source is specified.)

Extremity DOELAP Status

The draft Standard and Handbook for the DOELAP for extremity dosimetry have been submitted to all DOE Field Offices for review and comment. The comments will be evaluated and included as appropriate into the final Standard and Handbook. The DOE Order 5480.15 which regulates the performance of personnel dosimeters will be modified during 1992 and submitted for comment. The DOE will begin a phase of voluntary testing starting January, 1993. When the DOE Order has been modified to include extremity dosimetry performance testing and published, performance testing for extremity dosimetry systems will be mandatory for all DOE laboratories.

References

"Department of Energy Standard for the Performance Testing of Extremity Dosimeters", May 1991 Draft.

"Handbook for the Department of Energy Laboratory Accreditation Program for Extremity Dosimetry Systems", May 1991 Draft.

American National Standards Institute, Inc. 1983 American National Standard for Dosimetry - Personnel Dosimetry Performance - Criteria for Testing, American National Standard ANSI N13.11-1983.

Roberson, P.G., F.N. Eichner and W.D. Reece. 1989. "Determination of Photon Conversion Factors Relating Exposure and Dose", Health Physics, Vol. 57, No. 5, pp. 733-741, 1989.

International Standards Organization 1984 Reference Beta Radiations for Calibrating Dosemeters and Doseratemeters and for Determine Their Response as a Function of Beta Radiation Energy, International Standard ISO 6980-1984.

International Standards Organization 1979 X and Gamma Reference Radiations for Calibrating Dosemeters and Dose Ratemeters and for Determine Their Response as a Function of Photon Energy, International Standard ISO 4037-1979.

International Standards Organization 1983 X and Gamma Reference Radiations for Calibrating Dosemeters and Dose Ratemeters and for Determine Their Response as a Function of Photon Energy. Addendum 1: High Rate Series of Filtered X-radiations, International Standard ISO 4037-1979/Addendum 1.

International Standards Organization 1983 X and Gamma Reference Radiations for Calibrating Dosemeters and Dose Ratemeters and for Determine Their Response as a Function of Photon Energy. Amendment 1: Low Rate Series of Filtered X-radiations, International Standard ISO 4037-1979/Amendment 1.

International Standards Organization 1989 Neutron Reference Radiations for Calibrating Neutron-measuring Devices Used for Radiation Protection Purposes and for Determine Their Response as a Function of Neutron Energy, International Standard ISO 8529-1989.

CRITICAL REMARKS ON THE EURATOM BASIC STANDARDS

M. Heinzelmann, R. Hille
Forschungszentrum Jülich GmbH
D-5170 Jülich, Bundesrepublik Deutschland

ABSTRACT

The data in the Annex to the EURATOM Basic Standards give rise to criticism in the following points:

- The classification of radionuclides does not correspond to that of the relative radiotoxicity for some nuclides.
- The derived limit of tritium concentration in air does not make allowance for elemental tritium autooxidation.
- The limits of annual intake are in some cases higher than permissible due to the chemical toxicity.

INTRODUCTION

The "Basic Safety Standards for the Health Protection of the General Public and Workers Against the Dangers of Ionizing Radiation" [1,2] of the Commission of the European Communities, which are presently being revised, are the essential basis for the health physics regulations in the countries of the European Community. A few data in the extensive Annexes to the Basic Standards give rise to these critical remarks which primarily concern the figures given in the Annexes. The points in question will be discussed in the following.

RADIONUCLIDES WITH AN ACTIVITY CONCENTRATION BELOW $100 \text{ Bq} \cdot \text{g}^{-1}$

The activity concentration of the long-lived radionuclides Cd-113, Te-123, Gd-152 and Ta-180 is lower than $100 \text{ Bq} \cdot \text{g}^{-1}$ even for pure isotopes. These radionuclides are grouped in a radiotoxicity class, so that an activity limit is stipulated for these nuclides. For activities above this limit an authorization is required for handling these nuclides. This is not consistent with Article 4 of the Directive [1] according to which the requirements for reporting and obtaining prior authorization are not applicable if radioactive substances with a concentration of less than $100 \text{ Bq} \cdot \text{g}^{-1}$ are involved.

CLASSIFICATION OF RADIONUCLIDES ACCORDING TO THEIR RELATIVE RADIOTOXICITY

The most important radionuclides are grouped in Annex I to the Directive according to their relative radiotoxicity [2]. A comparison of the nuclides in the different radiotoxicity groups with the limits of annual intake in Annex 3 to the Directive shows that the limits of annual intake do not

correspond in each case with the radiotoxicity. Radiotoxicity is the toxicity of an incorporated nuclide and its daughter products due to ionizing radiation. The limits of annual intake should thus be a measure of radiotoxicity. Table 1a shows the isotopes of an element which have been incorrectly classified insofar as the isotope with the same or even higher limit of annual intake was allocated to a higher radiotoxicity group. Table 1b shows corresponding values for different elements.

DERIVED CONCENTRATION LIMITS FOR TRITIUM

Derived limits of concentration in the air inhaled are specified for elemental tritium and for tritiated water. The limit for elemental tritium ($2 \cdot 10^{10} \text{ Bq} \cdot \text{m}^{-3}$) is higher than that for tritiated water ($8 \cdot 10^5 \text{ Bq} \cdot \text{m}^{-3}$) by a factor of $2.5 \cdot 10^4$. In determining the derived concentration limit for elemental tritium, the autooxidation of tritium in air has obviously not been taken into account. According to Casaletto [3] the oxidation rate of elemental tritium in air is 1.5 % per day. Tritiated water is formed relatively quickly from elemental tritium due to autooxidation. A concentration of tritiated water amounting to $1 \cdot 10^{-4}$ of the concentration of elemental tritium is already formed after 10 minutes. The concentration ratio of tritiated water to elemental tritium is practically always higher than the ratio of the derived concentration limits. Moreover, in radiation protection monitoring it is hardly possible to detect concentrations of tritiated water amounting to less than 1 % of the concentration of elemental tritium using normal air monitoring devices. The high concentration limit for elemental tritium is thus not conservative and should be changed so that it covers at least the 1 % concentration of tritiated water which is difficult to measure.

ALLOWANCE FOR THE CHEMICAL TOXICITY

The limits of annual intake due to inhalation do not make allowance for the chemical toxicity with one exception (uranium). For various long-lived nuclides the limits of annual intake due to inhalation are higher than the values which can be derived from the maximum permissible workplace concentrations (MAK values) of conventional safety regulations [4]. For the nuclides Cd-113, In-115, Te-123, Ta-180 and Re-187 the limit of annual intake is higher by more than a factor of 10^3 than the corresponding value of conventional safety regulations. In such cases, the Euratom directives should make allowance - similar to uranium - to the chemical toxicity or at least refer to the values of conventional safety regulations.

LIMIT OF ANNUAL INTAKE THROUGH THE GASTRO-INTESTINAL TRACT FOR LONG-LIVED NUCLIDES

For certain long-lived isotopes (Cd-113; In-115; Te-123; Ta-180; Re-187) the limit of annual intake through the gastro-intestinal tract for individuals is so high that the amount corresponds to an average intake of 1 kg per day or more. A specification of these limits should be omitted since hardly 1 ‰ of these values is incorporated inadvertently.

REFERENCES

1. Richtlinie des Rates vom 15. Juli 1980 zur Änderung der Richtlinien, mit denen die Grundnormen für den Gesundheitsschutz der Bevölkerung und der Arbeitskräfte gegen Gefahren ionisierender Strahlungen festgelegt wurden.
Amtsblatt der Europäischen Gemeinschaften L246 vom 17. September 1980
2. Richtlinie des Rates vom 3. September 1984 zur Änderung der Richtlinie 80/836/Euratom hinsichtlich der Grundnormen für den Gesundheitsschutz der Bevölkerung und der Arbeitskräfte gegen die Gefahren ionisierender Strahlungen.
Amtsblatt der Europäischen Gemeinschaften L265 vom 5. Oktober 1984
3. Casaletto, G.J.; Gevantman, L.H. and Nash, J.B.
The Self-Radiation Oxidation of Tritium in Oxygen and Air
Report USNRDL-TR-565(1962)
4. MAK-Werte-Liste 1989
in: Betriebswacht 1990, Datenjahrbuch der gewerblichen Berufsgenossenschaften, Sankt Augustin, 149-187 (1989)

Table 1

Limits of annual intake for some nuclides
from different radiotoxicity groups

a) Isotopes of one element

b) Isotopes of different elements

nuclide	radiotoxicity group	$I_{j,L}^{*)}$	
		A *)	B *)
Tc-97m	III average	$2 \cdot 10^7$	$2 \cdot 10^7$
		$4 \cdot 10^6$	
Tc-99	IV low	$2 \cdot 10^7$	$1 \cdot 10^7$
		$2 \cdot 10^6$	
I-126	II high	$1 \cdot 10^5$	$8 \cdot 10^4$
I-129	IV low	$3 \cdot 10^4$	$2 \cdot 10^4$
U-233	I very high	$4 \cdot 10^3$	$4 \cdot 10^4$
		$3 \cdot 10^3$	$7 \cdot 10^5$
		$1 \cdot 10^2$	
U-235	IV low	$5 \cdot 10^3$	$5 \cdot 10^4$
		$3 \cdot 10^3$	$7 \cdot 10^5$
		$2 \cdot 10^2$	

nuclide	radiotoxicity group	$I_{j,L}^{*)}$	
		A *)	B*)
Ra-226	I very high	$2 \cdot 10^3$	$7 \cdot 10^3$
Ac-225		$1 \cdot 10^3$ $2 \cdot 10^3$	$2 \cdot 10^5$
Th-232	II high	$1 \cdot 10^1$ 4	$3 \cdot 10^3$
Be-10	II high	$6 \cdot 10^5$ $5 \cdot 10^4$	$4 \cdot 10^6$
Al-26		$2 \cdot 10^5$ $3 \cdot 10^5$	$1 \cdot 10^6$
Sm-151		$4 \cdot 10^5$	$5 \cdot 10^7$
Am-242		$3 \cdot 10^5$	$2 \cdot 10^7$
I-129	IV low	$3 \cdot 10^4$	$2 \cdot 10^4$
Gd-152		$4 \cdot 10^1$	$6 \cdot 10^4$
		$2 \cdot 10^2$	

*) $I_{j,L}$ = limit of annual intake
 A = $I_{j,L}^{in}$ due to inhalation
 B = $I_{j,L}^{GI}$ through the gastro-intestinal tract

If several limits are specified, these apply to chemically different compounds.

LES PROBLÈMES DE L'IMPLANTATION D'UN PROGRAMME UNIVERSITAIRE DE RADIOPROTECTION

J.C. Borges, K.C. Caballero

EE/COPPE/UFRJ - Caixa Postal 68.509
Rio de Janeiro - RJ - Brésil

IMPLANTATION OF A RADIOPROTECTION PLAN FOR BRAZILIAN UNIVERSITIES

In 1984, the Federal University of Rio de Janeiro started a wide radioprotection program, installing a Radiological Control Service. The experience acquired, dealing with its own problems, plus data concerning similar problems obtained from other Brazilian universities, as well as the national legislation for this kind of activities, permitted the establishment of a standard radioprotection program for these universities.

INTRODUCTION

L'Université Fédérale de Rio de Janeiro a démarré en 1984, un vaste programme de radioprotection, pour attaquer des problèmes comme:

- 1 - une bonne connaissance:
 - a) des activités liées à l'utilisation des radiations ionisantes sur le campus ;
 - b) des niveaux dosimétriques et des risques concernés à ces activités;
- 2 - le contrôle médical des employés;
- 3 - la fiscalisation des activités plus dangereuses;
- 4 - la concession des bénéfices prévus par la législation brésilienne, surtout ceux concernant à des aspects financiers;
- 5 - l'entraînement des employés, selon leur tâche et niveau technique;
- 6 - la centralisation du contrôle dosimétrique des travailleurs;

D'un autre côté, on a aussi bien analysé la législation nationale concernant les activités avec des radiations, séparée en deux blocs:

- 1 - les normes e procédures de travail;
- 2 - les droits travailistes.

Les problèmes les plus cruciaux rencontrés dans l'implantation du programme ont été d'ordre juridique, c'est à dire, comment établir des procédures de radioprotection et concéder des bénéfices travailistes face à l'ambiguïté et même les contradictions

de la législation mentionnée.

RECOMMENDATIONS

Un programme si général, pionnier dans le contexte des universités brésiliennes, a permis d'établir:

- 1 - le modèle d'un plan général de radioprotection pour les universités brésiliennes dont les principales recommandations résident sur:
 - a) l'établissement d'un Secrétariat Spécial de Contrôle des Activités Nucléaires, dans le contexte d'un Secrétariat Général de Médecine et Sécurité du Travail, déjà prévu par loi;
 - b) l'établissement d'un Laboratoire de Dosimétrie et Radioprotection, lié, si possible, à un département dont les activités soient essentiellement nucléaires;
 - c) le Laboratoire doit fournir au Secrétariat Nucléaire, le support technique pour les contrôles et décisions administratifs.
- 2 - des recommandations aux pouvoirs publics de changement de la législation actuelle, surtout son protectionnisme exagéré et anachronique:
 - a) la concession de bénéfices financiers selon les niveaux de dose des activités;
 - b) le droit à des bénéfices comme:
 - la réduction de la durée de travail semanal;
 - les vacances semestrales.

REFERENCES

- 1 - CNEN, Diretrizes Básicas de Radioproteção, Rio de Janeiro, 1988.
- 2 - Borges, J.C. Análise das Atividades com Radiações na UFRJ, Anais do 3º Congresso Geral de Energia Nuclear, Associação Brasileira de Energia Nuclear - ABEN, Rio de Janeiro, 1990.

**INTRODUCING UNIKORNES - (United Kingdom Occupational
Radionuclide Exposure Study)**

WOODHOUSE J A, SLOVAK A J M, WOOD R

Post-mortem studies on occupationally exposed workers represent a major potential source of information for the development of improved metabolic models for use in radiological protection dosimetry. They are particularly valuable in the context of exposure to materials such as plutonium and uranium, which are widely encountered in the nuclear industry, and for which in vivo monitoring possibilities are limited given the lack of sufficiently energetic photon emissions.

Within the UK an initiative has now been taken to set up a joint industry programme of post-mortem studies to investigate the deposition patterns of radionuclides in occupationally exposed persons. Partners in the joint programme are currently BNFL, NRPB, AEA Technology and MoD. It is intended to maintain close links with the USTR and USUR programmes and with any future developments that may arise in Europe.

The timing of this initiative is important. As radiological protection practices have developed over the years the frequency of occurrence and severity of events leading to internal contamination has decreased. There is, therefore, a dwindling population of cases believed to have sustained levels of internal contamination which would constitute the most "useful" cases for post-mortem investigation. The window of opportunity is ever closing.

This paper outlines the objectives of the studies proposed and describes progress to date in setting up the project. The philosophy of approach is discussed along with the particular problem areas which must be addressed in setting up and managing a study of this nature.

J A Woodhouse
British Nuclear Fuels plc
Risley
Warrington WA3 6AS
Cheshire
UK

THE ROLE OF RADIOACTIVITY MONITORING PROGRAMMES IN THE STUDY OF ENVIRONMENTAL PROCESSES

G. J. Hunt
Fisheries Radiological Inspectorate
Fisheries Laboratory
Lowestoft, Suffolk, NR33 0HT, England

ABSTRACT

The objectives of environmental monitoring are briefly reviewed. The suggestion is made that the potential for data to provide information on environmental processes should be borne in mind when setting up monitoring programmes. Two examples of the type of information that can be gained are given relevant to the marine environment near Sellafield. First, studies of dispersion timescales for actinides show that there has been an apparent increase in these timescales in recent years. Secondly, studies of remobilisation of caesium-137 show that about 700 TBq have been remobilised from the sea bed near Sellafield in the period 1983-1990.

OBJECTIVES OF ENVIRONMENTAL MONITORING PROGRAMMES

In designing monitoring programmes for radioactivity in the environment full consideration is needed of the objectives which the programmes are required to fulfil. Relevant objectives have been reviewed in many fora: the International Commission on Radiological Protection (ICRP) and International Atomic Energy Agency (IAEA) have provided guidance in an international context (ICRP, 1985; IAEA, 1975). These authorities are in general agreement that there are primary objectives related to:

- a) assessment of actual or potential doses to critical groups and populations;
- b) demonstration of compliance with regulations;
- c) assessment of the adequacy of controls on sources including surveillance for any unplanned releases to the environment.

There are also subsidiary objectives which may be considered when a need for monitoring has been established, and may be summarised as:

- d) improvement of knowledge of the relationship between sources and exposures (including sub-critical exposures) under different conditions so as to keep under review the transfer models and dose predictions, including those in the event of emergency;
- e) recording of long-term changes or trends due to sources;
- f) provision of information for the public;

© Crown copyright

g) provision of information relevant to elucidating environmental processes.

In practice, different degrees of importance may be attached to these objectives by different organisations and under different circumstances. For example, an operator of a nuclear installation would probably see (b) as quite important while a regulator might place more emphasis on (a) and (c). ICRP (1985) make the distinction between source-related and person-related environmental monitoring; the latter applies to multiple or widely distributed (including natural) sources, and here objectives (c) and (d) might be adjudged important by a national authority. In an emergency, the main objective would be likely to be (a), with the emphasis on rapid compilation of data to enable judgements on the need for countermeasures, their extent, and to review their effectiveness.

PROVISION OF INFORMATION ON ENVIRONMENTAL PROCESSES

It is necessary to draw a clear distinction between research as the direct investigation of environmental mechanisms, and environmental monitoring, the results of which can contribute to understanding of such mechanisms. Research and monitoring properly have different objectives, and the main objectives of environmental monitoring are given above. However, when designing monitoring programmes, it is reasonable to bear in mind the potential for providing data on environmental processes and to seek to maximise the information that can be gained. Because of the objectives of environmental monitoring, there can be some advantages over research programmes in the type of data available. One particular advantage is that monitoring programmes can cover a long time series, such that when data are comparable, useful information can be derived on processes of long characteristic timescales. This is in contrast with many research programmes which, often through funding requirements, can tend to be more short-term.

This paper now presents two recent examples of the information which has been gained from monitoring programmes in relation to the dispersion of radionuclides in the Irish Sea from the British Nuclear Fuels plc (BNFL) Sellafield plant.

TIMESCALES FOR DISPERSION OF ACTINIDES IN THE IRISH SEA

Discharges of plutonium and americium to the Irish Sea from Sellafield, which are authorised by the UK Government, have decreased significantly over the past ~15 years. The reductions are due to the operation of treatment facilities, and further treatment plant is due to be commissioned in 1992. Marine discharges of alpha emitters in 1990 were some 2.5% of levels in 1975. Resulting concentrations of actinides in environmental materials are also decreasing, and for ^{241}Am this is happening despite ingrowth from past discharges of ^{241}Pu . Reliable monitoring data from this laboratory for actinides, in time series which allow analysis, date from the early 1970s and this data has been used to investigate the timescale over which the effects of discharges remain reflected in marine materials. A simple model was used, based on a sum of exponential terms to represent the availability of plutonium or americium in a given year due to discharges in previous years (Hunt, 1985). Fits to monitoring data were reasonable and gave values of characteristic "availability times" for different materials. More data are now available than when this technique was first used, and investigations are being made of the adequacy of this simple approach. Table 1 compares availability times estimated with data up to 1983 with those using the same simple methodology and data up to 1989.

Table 1 Availability times for Pu and Am in marine materials near Sellafield

Material	Sampling area/ landing point	Availability times (years)			
		Plutonium		Americium	
		Data to 1983	to 1989	Data to 1983	to 1989
Winkles	St Bees	4	5	7	8.5
Mussels	St Bees	3	4	6	8
Crabs	Sellafield shore area	1.5	3.5	4	5
Plaice	Whitchaven	2	4.5	4	5.5
<i>Porphyra</i>	Braystones	2	2	6	5
Surface sediment	Newbiggin	4	5	6	6.5

It can be seen that there are increases in availability times using the longer time series, and these increases are significant (on the basis of paired "t" tests, $p < 0.01$ for plutonium data, $p < 0.05$ for americium data). This suggests that the environmental processes governing the dilution and dispersion of these nuclides (mainly by uptake on sediments) are more complex than may be described by a simple exponential, with the possibility of a contribution from terms with longer time constants than were first identifiable. This apparent increase in timescale for dispersion could be due to slower release than in the past of actinides from sediments; the remainder could be more strongly bound, or more deeply buried.

REMOBILISATION OF RADIONUCLIDES FROM THE SEDIMENT OF THE IRISH SEA

It is known that a large proportion of the undecayed radioactivity discharged to the eastern Irish Sea from Sellafield resides in the muddy, scabed sediments; this applies particularly for plutonium and americium, but also to radiocaesium (Woodhead, 1988). Under conditions of decreased sea water concentrations, as has resulted from the reduced discharges, it might be expected that sediment-bound radionuclides might be remobilised into the water column. This phenomenon has been examined by modelling methods, but has also been studied using data from the regular monitoring of seawater near Sellafield (Hunt and Kershaw, 1990).

Table 2 shows the results of regular monitoring of caesium-137 in sea water near Sellafield from 1983 to 1990, and the concentration expected on the basis of the discharge alone using a normalised concentration of 8.5 ± 1.9 (1σ) Bq l^{-1} per TBq year^{-1} discharged. This factor was derived for the period 1977 to 1982, when discharges were decreasing less rapidly than from 1983. The excess concentration measured was converted using this same factor to estimate the annual activities of caesium-137 remobilised in the Sellafield vicinity. This vicinity is taken to be that of the relatively well-mixed tidal plug over which the measured concentrations were averaged. It is estimated that a total of about 700 TBq have

Table 2 Remobilisation of ^{137}Cs in the Sellafield offshore vicinity

Year	Sellafield Discharge, TBq	Mean concentration in sea water, Bq l ⁻¹	Concentration without remobilisation ^a , Bq l ⁻¹	Concentration difference ^b , Bq l ⁻¹	Remobilised ^{137}Cs ^b , TBq
1983	1200	11.06	10.2	0.9 ± 2.5	100 ± 300
1984	434	4.63	3.7	1.0 ± 1.1	100 ± 120
1985	325	4.25	2.8	1.5 ± 1.0	180 ± 110
1986	17.9	0.97	0.15	0.8 ± 0.2	80 ^c ± 20
1987	11.8	0.65	0.10	0.55 ± 0.15	65 ± 18
1988	13.3	0.55	0.11	0.44 ± 0.15	51 ± 14
1989	28.6	0.62	0.24	0.38 ± 0.14	44 ± 16
1990	23.5	0.53	0.20	0.33 ± 0.12	39 ± 14
TOTAL.					700 ± 300

^a On basis of concentration normalised to discharge rate for 1977-82 (see text).

^b Errors represent ± 1 standard deviation based on propagated sampling uncertainties.

^c After subtraction of about 10 TBq due to input from Chernobyl.

been remobilised in this area from 1983 to 1990. In 1987, the rate of remobilisation of caesium was over five times as much as the amount discharged, but the difference has now decreased as equilibrium with the lower rates of discharge is being achieved.

CONCLUSIONS

Data collected for monitoring purposes near Sellafield have been used to provide information relevant to environmental processes. The potential for monitoring programmes to provide information of this nature should be recognised when setting them up.

REFERENCES

- Hunt, G. J., 1985. *Sci. Tot. Env.* **46** 261-278.
- Hunt, G. J. and Kershaw, P. J., 1990. *J. Radiol. Prot.* **10** 146-151.
- IAEA, 1975. *Safety Series 41*, Vienna.
- ICRP, 1985. *ICRP Publication 43. Annals. ICRP* (15) 1.
- Woodhead, D. S., 1988. In: "Radionuclides : A Tool for Oceanography", ed. C. Guary (Elsevier) 331-40.

**IMPLICATIONS OF 1990 ICRP RECOMMENDATIONS ON RADIATION
PROTECTION PRACTICES IN THE MINERAL SANDS INDUSTRY**

J. ("GEORGE") KOPERSKI

Westralian Sands Ltd, P.O.Box 96, Capel W.A. 6271, Australia

ABSTRACT

Implementation of the 1990 ICRP recommendations would require engineering, metallurgical and human aspects of the mineral sands dry separation processes to be addressed. The primary objective is to minimise radioactive dust levels within the dry plant environment. Refinements of radiation monitoring and dose assessment protocols are also warranted. To date, the engineering aspects have had the major impact on minimisation of radioactive dust levels in the dry plants. Effective doses from internal exposure to airborne dust of the most exposed workers should be at approx. 10 mSv/y level.

INTRODUCTION

Australia is the world's largest producer and exporter of heavy minerals (HM; specific gravity over 2.9) namely: ilmenite, leucoxene, rutile, zircon, monazite and xenotime. The last two are classified as radioactive HM, with monazite being of primary radiological safety concern. Monazite, a rare earth phosphate, typically contains 6% of thorium and 0.3% uranium.

There are two stages of HM production. Firstly, a heavy mineral concentrate (HMC), which is a mixture of HM, is extracted from the ore by applying wet, gravitational separation process. Subsequently, individual minerals are separated from the HMC. This process applies dry electrostatic and magnetic mineral separation techniques and takes place in dry separation plants. No chemical extraction of minerals takes place.

Mineral sands industry workers are exposed to external gamma radiation and internal, principally alpha, radiation from inhaled radioactive dust. Here, the impact comes from inhaled long-lived radionuclides of Th-232 and, to a lesser extent, U-238 series associated with airborne dust generated during the process. To date, internal irradiation has been the major source of the radiological impact on the industry workers (1). The radioactive content of the dust is mostly due to the monazite content in the HMC and, subsequently, due to imperfect monazite separation from other minerals.

In order to comfortably comply with the annual dose limit of 20 mSv implied by the 1990 ICRP recommendations, the engineering, metallurgical and human aspects of contemporary HM dry separation processes should be addressed. Each aspect may influence the amount of dust, hence airborne radioactivity, generated within the plant. A refinement of radiation monitoring techniques and the associated, conservative dose assessment protocols is also warranted.

ENGINEERING ASPECTS

The engineering aspects refer to improvements in dry plant design. Predominantly, this incorporates enclosing all open design dry separators, including mineral feed and collection systems, and installation of a ducted system of dust extraction from within the enclosures (Photo). Implementation of such major dust control measures may result in a decrease of ambient radioactivity levels by as much as an order of magnitude (Fig-Part A). Further decrease may be achieved by removal of monazite separation circuit from the main separation plant to an isolated, dedicated plant. Other measures applied to the handling of dry minerals include: enclosing of discharge points onto and from conveyor belts, enclosing of discharge points from gravity transfer chutes and sealing of the housing of bucket elevators used for vertical transport of minerals. Transfer of airborne dust between various parts of the plant by natural and thermal air currents may be prevented by wall partitioning and solid flooring between various plant levels.

Contemporary plants are usually compact, multilevel constructions employing significant gravitational transfer of minerals between multiple separation stages. This promotes mineral abrasion which, in turn, produces fine dust. New plant design should be of a low profile, at the expense of the compactness of the plant size. Downward gravitational movement and upward transfer of minerals by means of bucket elevators should be replaced by less dust generation prone means like eg. conveyor belts.

All those dust control measures could result in a major reduction - by up to an order of magnitude - of alpha activities recorded by personal monitoring devices (Fig-Part B). Hence, the effective doses from exposure to airborne dust of the most exposed workers would be at approx 10 mSv/y level.

METALLURGICAL ASPECTS

The metallurgical aspects refer to improvements in the efficiency of mineral separation and development of alternative processing methods.

Improved attritioning (ie removal of mineral grain coating) of the HMC would increase efficiency of electrostatic separation, thus reducing the number of dust generation-prone mineral separation stages. Depleted grain coating would result in reduced potential for fine dust generation from this source.

Alternative, wet separation processes of the HMC would markedly reduce dust generation in the plant. None of the processes trialled have exhibited both the mineral selectivity and operating costs to consider them as replacement for existing dry processes. However, some wet magnetic and mineral froth flotation techniques hold promise for future developments.

HUMAN ASPECTS

The human aspects refer to minimisation of radiological impact on workers resulting from the adopted work practices. The level of exposure of different workers performing identical tasks in the same dry plant may widely differ. Provision of in-house, uniform, practical work training programs would alleviate the problem. Minimising worker's residence time in the plant would further reduce exposure. This could be achieved by remote plant monitoring and process control and substitution of manual mineral sampling for product quality control analyses by automatic on stream analyses. Whenever feasible, manual removal of mineral spillage should be replaced by vacuuming.

RADIATION MONITORING AND DOSE ASSESSMENT

Contemporary dose assessment and default values used for internal dose estimation in Australia may have been overly conservative (2). More accurate monitoring followed by better estimates of internal doses have been warranted. The former has already resulted in reassessment of the mean personal AMAD of dry plant workers from 5 to over 10 μm (3) and effective respiratory protection factors for half-face particulate respirators of over 20, instead of 3.5 (4). Increased accuracy of personal monitoring could be achieved by replacement of a grab by time integrated dust sampling and by application of sampling heads emulating inspirable dust sampler criteria.

In order to improve present dose assessment protocol a series of radiation research priorities has been suggested (5) for dosimetry of monazite dust. Research on some of the topics has been in progress.

CONCLUSION

To date, the engineering aspects have had the major impact on minimisation of radioactive dust levels in Australian mineral sands dry plants. This should result in effective doses from internal exposure to airborne dust of the most exposed workers being approximately at the 10 mSv/y level.

REFERENCES

1. Mason G.C., Cooper M.B., Solomon S.B. and Wilks M.J., Evaluation of Radiological Hazards Associated with Mineral Sandmining, Proc. Int. Conf. Occupational Radiation Safety in Mining, Toronto, 1984, Editor: H. Stocker, Publisher: Canadian Nuclear Association, 607-611.
2. Hewson G.S., A Review of the Uncertainties in Internal Radiation Dose Assessment for Inhaled Thorium, Radiat. Prot. Aust. 1989, 7(2), 35-44.
3. Meunier G., Use of a Personal Cascade Impactor in the Mineral Sands Industry, Proc. Int. Conf. on OHS Minesafe International 1990, Perth, Publisher: Chamber of Mines and Energy of Western Australia Inc., 733-737.

4. Koperski J., "Thru-Mask" Technique of Personal Dust Sampling, *ibid*, 723-726.
5. Hewson G.S. and Hartley B.M, Radiation Research Priorities in the Mineral Sands Industry, *J. Radiol. Prot.* 1990, 10(3), 221-229.

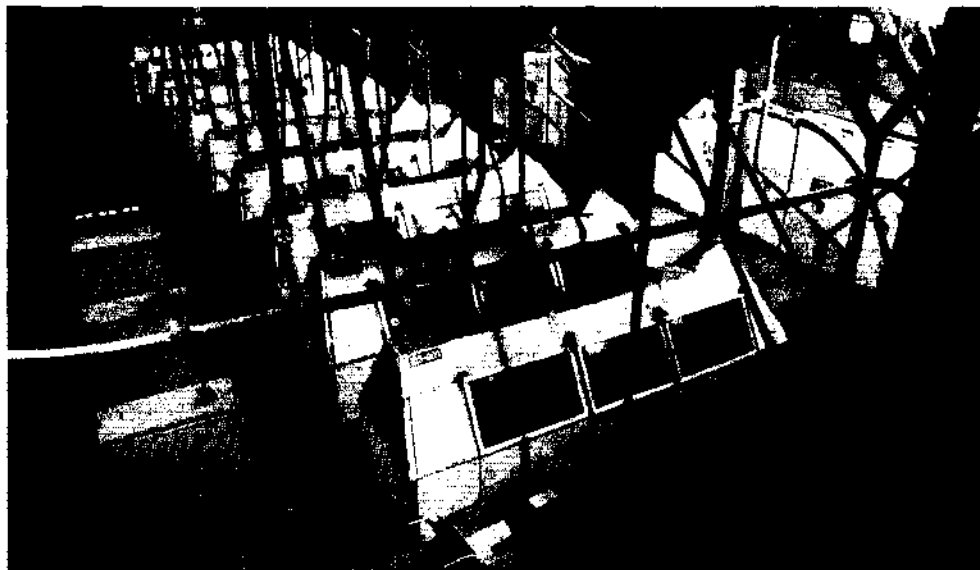
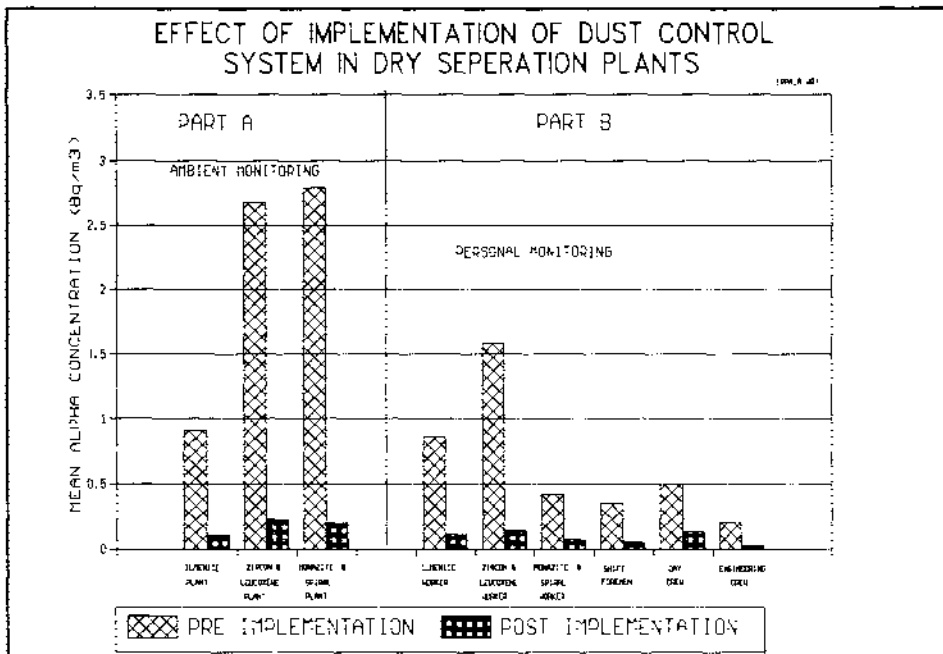

INTERIOR OF MINERAL SANDS DRY SEPERATION PLANT

DETECTION AND DIFFERENTIATION OF CONTAMINATION THROUGH A
COMPARISON OF OBSERVED LEVELS IN HISTORICAL
ENVIRONMENTAL SAMPLING DATA

D. H. Denham and K. R. Price

Pacific Northwest Laboratory
Richland, Washington

ABSTRACT

In summarizing more than a decade of environmental monitoring data from the Hanford Site, we noted that grouping data by analysis, rather than by medium, enhanced visual as well as statistical interpretations. By plotting running-averages of individual radionuclides on the same graph, for different media, we evaluated environmental trends to determine whether or not a local impact had been observed. This approach may enhance ones ability to interpret environmental monitoring data collected following an unplanned release of radionuclides. This technique provides a more holistic approach to the evaluation of environmental monitoring data than has traditionally been practiced.

INTRODUCTION

Nuclear operations at the Hanford Site have been conducted since the mid 1940s. The Hanford Site, comprising an area of just under 1500 km², is located in a semi-arid region of southcentral Washington State and is effectively bounded on the north and east by the Columbia River. Air, water, and native vegetation samples have been collected for analysis of radionuclide levels since Site operations began. Other media, such as selected foodstuffs and wildlife, were added to the routine program in the 1960s, and during the 1980s fruit, wine, wheat, and alfalfa samples were added.

Establishing appropriate and logical interpretations of environmental monitoring data is difficult in the absence of similar data obtained either concurrently from another location or from an historical trend. Thus, grouping techniques have been used to provide better interpretation of historical Hanford environmental data (over time or space or both) for visual as well as statistical interpretation. The traditional method has been to compare the data representing potentially affected locations (i.e., indicator locations) with data for background or control locations.

Plotting individual radionuclide data together, for each of several media, rather than by medium (the traditional method of grouping environmental data), permits the comparison of trends in one medium with similar or dissimilar trends in another. For long-lived radionuclides, such as strontium-90 or cesium-137, similar long-term trends might be expected for air, native vegetation, soil, and farm products. If similar trends are not observed, then either a sampling and/or analytical bias may have occurred in one or more of the media evaluated, or more importantly a local impact may have been detected. In the former case, these dissimilarities could suggest the need to reevaluate the monitoring program for representativeness of samples and accuracy of data. On the other hand, if a local impact appears to have been observed, additional confirmatory sampling and analysis may be required. It is important to note that short-term changes in some media may not be reflected in other media because of differences in environmental pathways or sampling frequencies.

Determining how to best use environmental monitoring data in the event of an emergency is especially challenging, because the data are often not available until well after protective action recommendations have been made. Because only a limited number of environmental samples are available in the early stages of an emergency, it is essential that the available data be appropriately evaluated and interpreted.¹ During an emergency, having available plots of long-term data trends and preestablished protocols for grouping the data are critical for evaluating environmental monitoring data.

EVALUATION TECHNIQUE

The method used to display data for this paper was sequential plotting of 5-year running averages as a function of time, which has the potential advantage of revealing trends or periodicity in the data. In this technique, 5-year groups of data are averaged to provide the result to be plotted for the last year of that group (e.g., the 1977 through 1981 results were averaged to provide the result to be plotted for 1981). Similarly, the 1978 through 1982 values were averaged to provide the 1982 running-average result. Then, the next 5-year period of values were averaged and similarly plotted and the process was continued until the latest year value was obtained. These running-average graphs were then plotted, by individual radionuclide, for several media collected from a given location or region.

Running-average summaries of the observed radiological conditions in both upwind and downwind locations from the Site are included for strontium-90, cesium-137, and plutonium-239 in several media. The environmental media include airborne particulates (A), milk (M), produce (P, leafy vegetables), soil (S), and native vegetation (V). Although other sampling media (e.g., wildlife, fruit and wine, wheat and alfalfa) are included in the routine Hanford surveillance program, the relatively small number of data available precluded this type of comparative analyses.

OBSERVATIONS

Examples of the long-term trends for strontium-90, cesium-137, and plutonium-239,240 are shown in Figures 1 through 3, respectively, using data from reports for the Hanford Site.²⁻⁸ The dissimilar trend shown in Figure 1 for soil compared to the other media is apparently the result of

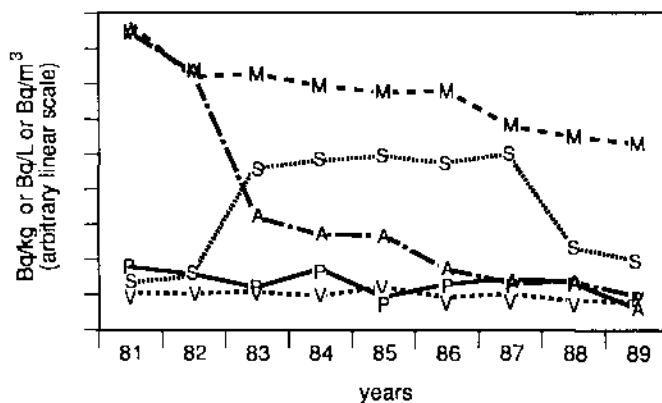

FIGURE 1. Five-Year Running Average Concentrations of Strontium-90 at an Upwind, Background Location.

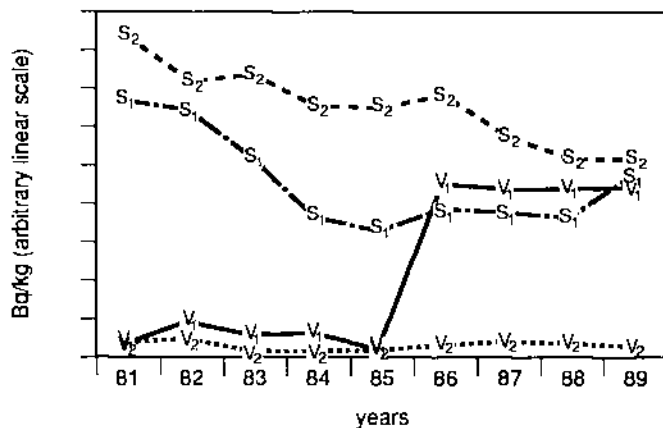

FIGURE 2. Five-Year Running Average Concentrations of Cesium-137 at Two Different Downwind Locations

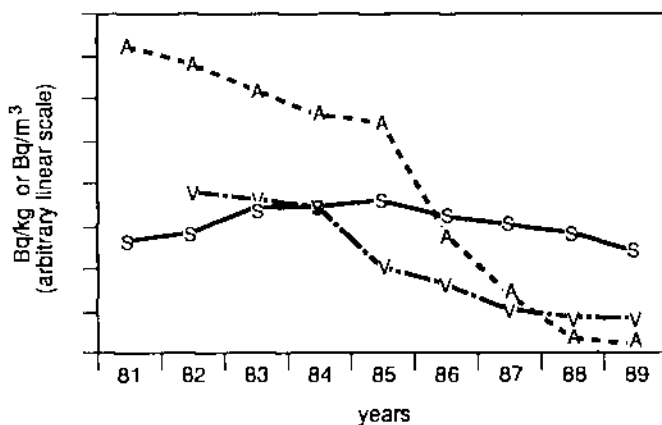

FIGURE 3. Five-Year Running Average Concentrations of Plutonium-239, 240 at an Upwind, Background Location

sampling or analytical biases. Figure 2 clearly shows the influence of fallout from Chernobyl in 1986 on native vegetation samples collected soon after the accident. The samples from location 1 were collected shortly after Chernobyl fallout in the Tri Cities, whereas the samples from location 2 were collected prior to that time. Figure 3 provides a comparison of long-term plutonium concentrations in air, soil, and vegetation samples from the local environs. The apparent precipitous decrease in airborne levels of plutonium was caused by a change in analytical procedures. However, the overall trend has been downward since the world-wide cessation of atmospheric testing of nuclear weapons occurred in the early 1980s.

CONCLUSIONS

The use of this technique provides a better understanding of historical contamination levels and enhances the ability to detect and differentiate the presence of local contaminants from those contaminants that might have originated elsewhere. This technique may also be useful following the release of contaminants during an emergency situation.

REFERENCES

1. Denham, D. H. 1991. "Use of Environmental Monitoring Data in Support of Emergency Preparedness and Response," in Proceedings Third Topical Meeting on Emergency Preparedness and Response, April 16-19, 1991, Chicago, Illinois, pp. 127-130, American Nuclear Society, La Grange Park, Illinois.
2. Houston, J. R., and Blumer, P. J. 1978. Environmental Surveillance at Hanford for CY-1977, PNL-2432, Pacific Northwest Laboratory, Richland, Washington.
3. Price, K. R. 1986. Environmental Monitoring at Hanford for 1985, PNL-5817, Pacific Northwest Laboratory, Richland, Washington.
4. Pacific Northwest Laboratory. 1987. Environmental Monitoring at Hanford for 1986, PNL-6120, Pacific Northwest Laboratory, Richland, Washington.
5. Jaquish, R. J., and Mitchell, P. J., Eds. 1988. Environmental Monitoring at Hanford for 1987, PNL-6464, Pacific Northwest Laboratory, Richland, Washington.
6. Jaquish, R. J., and Bryce, R. W., Eds. 1989. Hanford Site Environmental Report for Calendar Year 1988, PNL-6825, Pacific Northwest Laboratory, Richland, Washington.
7. Jaquish, R. J., and Bryce, R. W., Eds. 1990. Hanford Site Environmental Report for Calendar Year 1988, PNL-7346, Pacific Northwest Laboratory, Richland, Washington.
8. Price, K. R. 1988. A Review of Historical Data on the Radionuclide Content of Soil Samples Collected from the Hanford Site and Vicinity, PNL-6734, Pacific Northwest Laboratory, Richland, Washington.

ACKNOWLEDGEMENT

This study was supported by the U.S. Department of Energy under Contract DE-AC06-76RLO 1830.

LE CESIUM 137 DANS LA NOIX DE COCO EN POLYNESIE FRANCAISE :
CONTRIBUTION A L'EXPOSITION DE LA POPULATION

C. POLETIKO¹, C. ARNOULD¹, J. SARBACH¹, J. P. BABLET², R. DUCOUSSO²

1. Laboratoire d'étude et de surveillance de l'environnement
BP 519 Papeete, Polynésie française

2 Service mixte de contrôle biologique
BP 16 91311 Monthléry cédex

137 CS CONTENT IN COCONUT WATER AND COPRA IN FRENCH POLYNESIA :
CONTRIBUTION TO THE DOSE FOR POPULATION

Coconut tree has the peculiarity to be a good integrator for alkaline metals. The isotope 137 of cesium, which was generated during previous atmospheric nuclear tests, has a high fission yield and a half-life of about 30 years; this nuclide is supposed to be still present in food chain in French Polynesia. In this food chain coconut water and coconut copra are ingested depending upon diet customs and areas of French Polynesia. For some islands, among local foodstuffs, cesium 137 content in coconut highly contributes to the dose.

Spectrometry gamma results and annual doses calculation since 1966 are displayed.

INTRODUCTION

La France a procédé en Polynésie Française à des expérimentations nucléaires atmosphériques de 1966 à 1974, depuis 1975 ces essais sont souterrains. Depuis 1965, un programme de surveillance de la Polynésie a été mis en place pour contrôler la faune et la flore dans les zones intéressées par les essais nucléaires. Il a porté, notamment, sur les denrées alimentaires; parmi celles-ci la noix de coco revêt une importance particulière, d'autant que le cocotier s'avère être un bon intégrateur des métaux alcalins.

L'eau de coco est beaucoup consommée en Polynésie principalement sur les atolls où la ration quotidienne moyenne est estimée, selon les enquêtes alimentaires, à 1 litre par personne. Le coprah entre moins dans l'alimentation humaine, mais participe très largement à l'alimentation du bétail. L'évolution de la teneur en césium 137 des noix de coco prélevées depuis 1967 est présentée ainsi que la méthodologie mise en oeuvre par le LESE, la répartition géographique des radionucléides présents dans l'eau de coco et le coprah. La dosimétrie pour la population est calculée à partir des données d'enquêtes alimentaires.

PARTIE EXPERIMENTALE

Le réseau de prélèvement comprend 43 îles ou atolls, répartis dans la totalité des archipels de la Polynésie Française. On estime que l'alimentation de 90% de la population est constamment et directement surveillée. Pour simplifier la présentation des résultats, on a divisé l'ensemble de la Polynésie en 4 zones en fonction de l'éloignement de la source (Mururoa et Fangataufa).

la zone I de 0 à 20 km
zone II de 20 à 250 km
zone III de 250 à 500 km
zone IV > 500 km

Le nombre des échantillons nécessaires aux mesures a été d'environ 70 000 noix de coco entre 1967 et 1988 inclus. Pour une sensibilité convenable il faut mesurer 50 g de cendres soit environ 10 litres d'eau de coco ce qui correspond au contenu de 30 à 40 noix.

Pour le coprah il faut 4 kg pour obtenir 50 g de cendre: ceci provient d'environ 20 noix.

Les échantillons sont pesés puis séchés à l'étuve à 120°C pendant 48 heures. Puis les échantillons sont incinérés à 500°C pendant 24 heures, les cendres obtenues sont pesées et homogénéisées et comptées dans des boîtes de 60 mm de diamètre et 30 mm de hauteur. La mesure du césium 137 par spectrométrie gamma a été réalisée au moyen d'un détecteur à cristal d'iode de sodium activé au thallium (NaI Tl), afin d'éviter d'introduire une variation au cours du temps. Ce détecteur était placé dans une enceinte blindée au plomb (CBMJ de Lomcr); les temps de comptage étaient de 200 minutes. A partir de 1981, les résultats obtenus par le LESE font l'objet d'intercomparaisons avec le service central de protection contre les rayonnements ionisants (SCPRI) qui est le laboratoire de référence de l'organisation mondiale de la santé (OMS).

Les résultats sont rassemblés dans le tableau ci-après.

-1

Moyennes annuelles de la teneur en césium 137 (en Bq.kg Frais)

Année	Zone I		Zone II		Zone III		Zone IV	
	Eau de coco	Coprah	Eau de coco	Coprah	Eau de coco	Coprah	Eau de coco	Coprah
1967	6,18	5,49	6,46	20,44	6,75	18,81	5,12	7,32
1968	4,99	11,22	3,81	14,21	1,05	7,19	3,53	9,35
1969	2,49	8,07	3,59	15,98	2,16	9,95	2,19	7,79
1970	2,24	7,84	9,79	31,36	1,88	10,08	1,58	5,41
1971	3,61	6,66	6,99	51,74	2,21	9,15	1,39	4,32
1972	2,26	7,68	8,62	25,36	2,08	8,95	1,22	4,58
1973	1,29	7,84	9,93	22,81	2,77	10,66	0,81	5,16
1974	0,94	5,27	11,44	41,06	2,69	12,85	1,49	4,63
1975	0,85	4,37	3,14	12,48	2,58	7,54	0,74	2,62
1976	0,76	6,10	3,87	28,58	2,20	10,12	0,51	2,89
1977	0,65	4,70	6,28	29,83	2,88	11,27	0,60	3,11
1978	1,20	4,74	7,62	17,62	1,78	4,55	0,81	5,68
1979	0,82	3,44	2,61	20,83	0,54	2,13	0,80	2,72
1980	0,65	1,87	3,11	20,28	0,77	2,67	0,35	3,19
1981	0,18	3,48	4,13	19,29	1,03	4,15	0,68	3,07
1982	0,61	1,42	4,88	8,57	0,56	4,35	1,07	2,60
1983	0,36	2,61		10,91	0,44	4,85	1,46	2,56
1984		1,04	2,66	11,93	0,47	6,88	0,58	2,70
1985	0,20	0,99	2,39	6,85	0,56	2,49	0,85	1,48
1986	0,32	1,48	1,07	5,49	0,23	0,61	0,68	2,30
1987	0,44	0,96	2,05	10,19	0,66	1,31	0,48	5,89
1989	0,92	3,24	1,24	4,99	0,62	3,71	0,55	2,34

CONCLUSIONS

Pour les deux séries d'échantillons, la décroissance de la teneur en césium 137 est constatée depuis le début de la période d'observation et sans discontinuité à partir de 1974, dernière année des essais atmosphériques. Il est, par conséquent, manifeste, qu'aucune injection de radionucléides ne s'est produite dans l'environnement polynésien après la fin des expérimentations aériennes. De plus l'absence de grandes variations pendant la période allant de 1967 à 1974 signifie que les retombées consécutives aux essais aériens de Mururoa et Fangataufa n'ont représenté qu'une partie relativement faible des retombées mondiales (16%).

En tenant compte des rations alimentaires définies après enquêtes auprès des populations, l'équivalent de dose efficace annuel dû au césium 137 chez l'adulte entre 1971 et 1988, en différents lieux est résumé ci-après :

	Equivalent de dose efficace annuel dû au ¹³⁷ Cs (μ Sv.an ⁻¹)				Part de l'eau de coco et du coprah dans le total en %	
	Total par ingestion		Par l'eau de coco et le coprah		1971	1988
	1971	1988	1971	1988	1971	1988
Tureia..	55,10	21,96	35,00	15,52	64	71
Hao..	4,44	0,83	3,55	0,58	80	70
Papeete	2,21*	1,74	0,19*	0,13	9	7

Les résultats présentés (cf. supra) pour la noix de coco sont en cohérence avec l'ensemble des mesures opérées sur les échantillons de la ration alimentaire totale. La noix de coco constitue pour certains atolls le principal vecteur de la dose annuelle pour la population.

L'exposition annuelle actuelle, pour l'ensemble de la ration alimentaire par exemple à Tureia, correspond à 0,44 % de la limite admissible et elle a été au maximum de 1,10 % en 1971.

* données de 1973.

BIBLIOGRAPHIE

1. BABLET J.P., CAYET O. - Le monde vivant des atolls (Polynésie Française, Tuamotu - Gambier). (Publication n°28 de la Société des Océanistes), PARIS : Musée de l'homme, 1972.
2. BADIE C., ARNOULD C., SARBACH J., ARNAUD M., LEMERCTER R., BERNARD C., HOWELL P., TEXIER T. - Teneur en Sr 90 de dents humaines collectées en Polynésie Française. Radioprotection, 1987, 22, 4, 325-332.
3. BAIR W.J., HEALY J.W., WACHHOLZ B.N. - The meaning of radiation at Bikini atoll. US Department of energy, Washington D.C., 1980.
4. COMMUNAUTES EUROPEENNES (CONSEIL) - Directive du Conseil du 3 septembre 1984, modifiant la directive 80/836/Euratom en ce qui concerne les normes de base relatives à la protection sanitaire de la population et des travailleurs contre les dangers résultant des rayonnements ionisants (84/467/Euratom). J. Off. Comm. Eur., 1984 L265 14 - (5 octobre).
5. FINSTON R. - Radiation dosage In : Bikini atoll rehabilitation committee, Report N°4, Status March 31, 1986, Appendix D.
6. GROUZELLE C., DOMINIQUE M., LAFAY F., DUCOUSSO R. - Résultat d'une enquête alimentaire effectuée à Tahiti de 1980 à 1982. Rapport CEA-R-5304, 1985, 108 p.
7. GUERIN M. - Plantes utiles préeuropéennes. In : Encyclopédie de la Polynésie, vol. 2 (C. GLEIZAL, Ed.) Multipress, 1986.
8. INTERNATIONAL COMMISSION ON RADIOLOGICAL PROTECTION - Recommendation of the International commission on radiological protection (ICPR publication 26). Oxford : Pergamon Press, 1977, 53 p.
9. MEYER J., MATHIEU J., SEGUY M., GROUZELLE C., DUCOUSSO R. - Détermination de certaines constantes chimiques d'espèces tropicales végétales et animales, destinées à l'alimentation. Rapport CEA-R-5130, 1981.
10. MORONEY J.R. - Radioactive fallout in the southern hemisphere from nuclear weapons tests. Rapport Australien, ARL-TR-013, 1979.
11. REPUBLIQUE FRANCAISE - Commissariat à l'énergie atomique et Direction des Centres d'expérimentations nucléaires. Surveillance de la radioactivité en 1988. CEA-DPS, BP 6, 92265 Fontenay-aux-Roses Cédex.
12. UNITED NATIONS SCIENTIFIC COMMITTEE ON THE EFFECTS OF ATOMIC RADIATION (UNSCEAR) - Ionising radiation : sources and biological effects, report to the general assembly, New York : Nations Unies, 1982, page 221.
13. KABIS de SAINT CHAMAS I., BABLET JP., ARNOULD C., DUCOUSSO R., Evolution de la teneur en césium 137 depuis 1967 dans l'eau de coco et le coprah en Polynésie Française. Radioprotection, GEDIM, 1991, Vol. 26, n°1, pages 75 à 88.

RADIATION PROTECTION RELATED TO THE
ENVIRONMENT OF THE FINNISH NUCLEAR
POWER PLANTS

A. Vuorinen, O. Vilkamo and E. Ilus
Finnish Centre for Radiation
and Nuclear Safety

ABSTRACT

The aim of radiation protection is to keep doses as low as reasonably achievable. In Finland there has been, since 1976, a regulatory limit of 0.1 mSv/a for the maximum individual effective dose commitment in the environment of nuclear power plants. The control of operation at and releases from the Finnish nuclear power plants as well as the monitoring of the environment of the plants have indicated that this goal is clearly achieved. New regulations for the safety of nuclear power plants were issued in 1991 as the decision of the Council of State aiming at further decreasing the risks of postulated and severe accidents.

INTRODUCTION

There are at present four nuclear power reactors operating in Finland. Two of them are 440 MWe PWR-units (in Loviisa, on the south coast of Finland) and the other two are 710 MWe BWR-units (in Olkiluoto, on the west coast of Finland). There are interim spent fuel storages at both power plant sites and a final repository for operational radioactive wastes on-site of the Olkiluoto plant.

The Finnish Centre for Radiation and Nuclear Safety (STUK) is the regulatory body responsible for both radiation protection and nuclear safety. Its regulation of the operation of the nuclear power plants covers all aspects that affect plant safety and the releases of radioactive materials into the environment.

Limitation of radiation exposure in the environment of a nuclear power plant has since the commissioning of the nuclear power plants been based on three main goals:

- ALARA
- a limit for the maximum individual effective dose commitment of 0.1 mSv/a
- prevention of incidents and accidents as well as limitation of their potential consequences.

STUK has also given guidelines for the environmental monitoring programmes of the Finnish nuclear power plants. The aim of environmental monitoring is to extensively cover the ecosystem in order to give a picture of the spreading of radioactive materials released into the environment of a nuclear power plant.

The present Finnish Nuclear Energy Act and Decree came into force in 1988 /1/. A decision of the Council of State on the safety of nuclear power plants was issued in 1991 /2/. This includes regulations concerning the monitoring of releases of radioactive material and the limitation of radiation exposure in the environment of nuclear power plants.

ENVIRONMENTAL SURVEILLANCE

The monitoring of radioactivity in the environment of the nuclear power plants in Finland has been carried out since 1976. The environmental monitoring programme at every Finnish nuclear power plant site is extensive and includes about 500 samples taken annually from both the terrestrial and aquatic environments. Most of the sampling and laboratory analyses are performed by the environmental laboratory of STUK /3/.

The important food stuffs, such as milk, drinking water, grain, meat and garden products are collected. In addition, the monitoring programme includes samples of air, deposition, soil and hair moss in the terrestrial environment, as well as sea water, sinking matter, bottom sediments and indicator organisms in the aquatic environment. The samples are collected either continuously or 1 - 4 times a year depending on the sampling object. The bulk of samples is taken within a radius of 10 km from the power plant. In general the samples are analyzed gamma spectrometrically, but partly also for tritium, radioactive strontium and transuranic elements.

The results of environmental control so far have indicated that very small amounts of radioactivity originating in the Finnish nuclear power plants is regularly detected in certain samples. Most detections have been in the aquatic environment. In sea water samples ^3H is typically detected, sometimes also activated nuclides (^{54}Mn , ^{60}Co , $^{110\text{m}}\text{Ag}$) and fission products (^{134}Cs , ^{137}Cs). These are frequently found in samples of sinking matter and aquatic indicator organisms. However, ^{134}Cs and ^{137}Cs dominantly originate from the Chernobyl nuclear power plant disaster.

The results of the environmental measurements are consistent with the releases measured from the nuclear power plants. Because the actual detections in the environment are very low amounts of radioactivity, the effective dose equivalent commitment cannot be calculated based on them.

Calculated maximum individual effective dose commitments for the annual releases have been so far in the order of a few μSv (Figure 1). The main contribution has been due to ^{60}Co in aquatic discharges, respectively ^{14}C and ^{60}Co in airborne discharges.

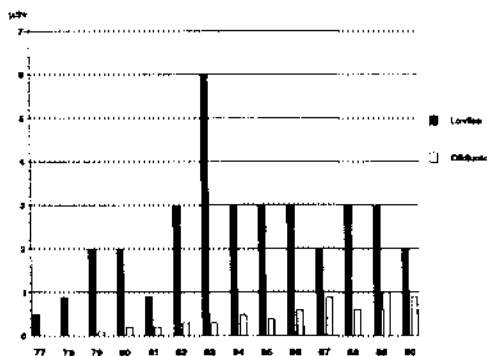

Figure 1.
Average doses of critical groups in the environs of Loviisa and Olkiluoto NPPs. (STUK/Blomqvist, Pusa 1991)

EVOLUTION IN REGULATION

During the 1980's STUK issued new guides dealing thoroughly with the safety of nuclear power plants /4 - 6/. These guides were aimed especially at the possible design of new nuclear power plants, but constituted at the same time the basis for the regulatory work dealing with operating plants. These were taken into account when the utilities planned and made further construction changes in their plants.

Based on the new Nuclear Energy Act and Decree this guidance was then followed by the decision of the Council of State on the general regulations for the safety of nuclear power plants /2/.

It is worth to refer to the present limit for a postulated accident: "The limit for the dose of an individual of the population, arising, as the result of a postulated accident, from external radiation in the period of one year and the simultaneous radioactive materials intake, is 5 mSv." and for a severe accident: "The limit for the release of radioactive materials arising from a severe accident is a release which causes neither acute harmful health effects to the population in the vicinity of the nuclear power plant nor any long-term restrictions on the use of extensive areas of land and water. For satisfying the requirement applied to long-term effects, the limit for an atmospheric release of ¹³⁷Cs is 100 TBq. The combined fall-out consisting of nuclides other than cesium-isotopes shall not cause, in the long term, starting three months from the accident, a hazard greater than would arise from a cesium release corresponding to the above-mentioned limit".

The possibility that, as the result of a severe accident, the above mentioned requirement is not met, shall be extremely small. This means that the probability of a severe accident shall be less than $10^{-6}/a$.

IMPROVEMENTS AT THE OPERATING NUCLEAR POWER PLANTS

Since the commissioning of the operating Finnish nuclear power plants, the utilities have made several technical changes at the plant units in order to improve their safety. Some of these improvements are more directly connected to decreasing the radiation risk of the population. Such are e.g. changes aiming at the limitation of the release of radioactive materials caused by a severe accident. Here the emphasis has been on ensuring the engineering safety functions and, especially, on keeping the reactor containment intact during severe accident conditions. In Olkiluoto (BWR) there is a filtered containment venting system and in Loviisa (PWR) an external containment spray system at each plant unit.

The utilities have made changes at the operating plants which would allow reasonable accident management. These include e.g. the sampling and measurement of radioactive material from the containment water and air during severe accident conditions.

The utilities are installing additional automatic radiation monitoring networks in the vicinity of the nuclear power plants. These comprise of four to six measuring stations located at a distance of 1 - 2 kilometers and about ten measuring stations at

a distance of 5 kilometers from the plant. All measuring stations send their results to a central unit on-site and are further connected to a national real time measuring network operated by authorities.

CONCLUSIONS

The safety targets shall be set so that they are clear and can be communicated to and understood by the public. Furthermore, operational experience shall prove that the set targets are clearly achieved.

We feel that the environmental limit of 0.1 mSv/a set in 1976 in Finland for nuclear power plant operation fulfils the requirements above. Besides this the goal has been to prevent accidents and to limit their potential consequences. This has led to more stringent requirements in recent regulation. The adaption of the requirements as well as the advancement of science and technology have produced further improvement at the operating nuclear power plants.

The experience of a single regulatory body responsible for both radiation protection and nuclear safety has been encouraging. A very important thing is the commitment of the operating organisation of a nuclear power plant to safety thinking and doing.

REFERENCES

1. Nuclear Energy Act and Decree, Unofficial translation by the authorities, Helsinki (1988)
2. STUK-B-YTO 87 Decision of the Council of State on the general regulations for the safety of nuclear power plants (395/91) and of a disposal facility for reactor waste (398/91), Unofficial translation, Helsinki (June 1991)
3. STUK-A92 Monitoring of radionuclides in the environs of the Finnish nuclear power stations in 1988, Helsinki (March 1991)
4. STUK, YVL-guide 1.0 Safety criteria for design of nuclear power plants, Helsinki (December 1982)
5. STUK, YVL-guide 7.1 Limitation of public exposure from nuclear installations, Helsinki (October 1987)
6. STUK, YVL-guide 2.2 Transient and accident analyses for justification of technical solutions at nuclear power plants, Helsinki (October 1987)

THE ORGANIZATION OF ENVIRONMENTAL RADIOACTIVITY CONTROL IN ITALY

G. Campos Venuti*, G. Monacelli^o, S. Piermattei**,
S. Risica*, A.F. Susanna **

*Istituto Superiore di Sanità - Rome - Italy

**ENEA/DISP - Rome - Italy

^oMinistero della Sanità - Rome - Italy

ABSTRACT

After the Chernobyl accident a great effort was made in Italy under the aegis of the Ministry of Health and the supervision of scientific institutions, mainly ENEA/DISP and Istituto Superiore di Sanità (National Institute of Health), to insure a wide coverage of the territory. This was accomplished to set up adequate environmental radioactivity monitoring networks covering the Italian territory as completely as possible.

This paper outlines the main features of the organization of the surveillance programmes. The role played by the scientific institutions and the Ministry of Health is underlined.

INTRODUCTION

The control of environmental radioactivity is one of the main problems faced by the responsible bodies in Italy since the mid fifties. The approach used consisted to monitor both the sites around nuclear plants and the fall-out from nuclear weapon tests.

The methodology adopted for the surveillance consisted both in source (nuclear plants) and person related monitoring (fall-out). In the first case a preliminary study of the site, of the source characteristics and of the radionuclides discharged into the environment, identified the main environmental components, the food samples to be analyzed and the important radionuclides to be mapped. The doses received by critical groups were also evaluated by dedicated calculation programmes.

In case of fall-out, person related monitoring networks were set up where the main environmental samples - air

particulates, deposition, surface and marine waters - were analyzed as well as the typical components of the human diet (cereals, meat, milk, etc.). Hystorical series of these data are available for some samples beginning from the middle fifties (1).

CHERNOBYL ACCIDENT: A LESSON LEARNED

In Italy as elsewhere the Chernobyl accident, because of its peculiarity, was instrumental for testing the adequacy of the overall system set up to control environmental radioactivity. It appears from the beginning that for such type of accident it is necessary to have a real time system to measure air particulates in air. The already existing one, although the sampling points were distributed all over the country in places representative of the air mass circulation, was not adequate. The filters collected in each station were sent to a central institute to be processed causing considerable delay.

Standardized sampling procedures were not available causing some inconsistencies in the collected data: mainly deposition and soil contamination. Moreover, the distribution of sampling points was uneven and difficulties were encountered in obtaining samples from some parts of the country. Consequently, steps were taken to reorganize the environmental radioactivity control system. (2)

PRESENT STATUS OF ENVIRONMENTAL RADIOACTIVITY CONTROL POLICY IN ITALY

The policy adopted in Italy for the control of environmental radioactivity, has produced the new organization of the surveillance (3). According to Italian law the Ministry of Health, under whose responsibility falls the environmental radioactivity control, delegated this activity to the local Authorities. An environmental measurement laboratory is going to be set up in each Administrative District in order to assure a more complete coverage of the territory as new laboratories are added to the existing ones.

The tasks of these laboratories are the following:

- 1) control of the artificial radiation sources distributed over their territory;
- 2) detection of large scale radioactive contamination from inside or outside the territory ;

3) characterization of natural radiation sources.

Each laboratory shall be equipped with basic instrumentation for gamma-ray measurements; specific systems both passive and active are also envisioned to detect radon and radon daughter products. Laboratories were also selected where radiochemical analyses can be carried out to detect beta and alpha emitters.

The apparatuses were provided directly by the Ministry of Health after a national bid. A Commission appointed by the Ministry of Health has the task to coordinate and promote the environmental monitoring activities.

For the early warning system of radioactivity in air, to be set up in case of emergency, several actions have been undertaken during last few years by the ad hoc appointed body of Department of Civil Protection in conjunction with the Ministry of Health. First of all a high sensitivity automatic network to detect radioactivity in air in real time, will be located in representative sampling stations. At present stage, 5 sites have been chosen where the detection systems will be installed. The collected data will be transmitted to a central institute (ENEA/DISP in Rome), meeting point of a Committee in charge to evaluate radioactivity data in case of emergency (CEVAD). This first step will test the performance of the entire system in order to reach the optimal configuration.

A second automatic network to detect radioactive particulates in air in real time will also be located in places selected by the environmental radioactivity control laboratories. This network will integrate the early warning one so that, in case of emergency, a narrower grid will be established all over the territory.

Both the systems will be equipped with high resolution Ge detectors and will have a high sensitivity, 10 - 100 mBq/m³ on Cs-137 peak, according to sampling duration.

RESULTS AND PERSPECTIVES

The organization of the environmental radioactivity measurement system existing in our country, requires a strict system of quality assurance and quality control. In this context, intercomparison exercises are organized on a two year basis among the various laboratories (typically in the number 20 to 30) to guarantee consistency and reproducibility of measurements. The intercomparison results will be presented

during this Conference. The importance of these programmes and the great efforts both technical and economical required to run such networks should be noted.

The funds allocated by the Ministry of Health during the period 1988-91 are of the order 16 Billion Italian lire (1.4 Million dollars) including apparatuses, general expenses, training, etc.

Special attention was paid to the training of personnel. In this context a good example was offered by the national survey on natural radiation indoors (4), where a close cooperation, including training, was established among the Central Institutes (ENEA/DISP and Istituto Superiore di Sanità) and the various laboratories at District level. Other specific environmental surveys are being planned for the future which will create the opportunity to exchange experiences and views.

The laboratories entrusted with the environmental control programme are sending the data of the measurements to the Ministry of Health. A real time network for the transmission of data is being planned. The network will connect each laboratory with the Ministry of Health, ENEA/DISP, the Istituto Superiore di Sanità and the National Institute for the prevention and safety in working places.

REFERENCES

- 1) Faloci, C., Manciozzi, S., Piermattei, S., Susanna, A. F., 1988 Results of 30 years of environmental surveillance in Italy. Proc. of the VII IRPA Conference, 922 - 925.
- 2) Campos-Venuti, G., Piermattei, S., 1988 Méthodologie de la detection de la radioactivité dans l'environnement, Radioprotection, 23, 121 - 131.
- 3) Campos-Venuti, G., Piermattei, S., Risica, S., Susanna, A.F., 1990 A new system for the control of environmental radioactivity in Italy, Proc. of an International Symposium on Radiation protection infrastructure, IAEA SM 309, 333 - 339.
- 4) Bochicchio, F., Campos-Venuti, G., Piermattei, S., Risica, S., Tommasino, L., Torri, G., 1991 Results of the representative survey on indoor radon in Northern Italy. Proceedings of the Vth International NRE Symposium. (In press).

ENVIRONMENTAL RADIOLOGICAL MONITORING AROUND URANIUM MINING AND MILLING SITES IN ARGENTINA

A.R. Curti, A.M. Bomben, J.C. Gómez and A.A. Oliveira

Gerencia de Seguridad Radiológica y Nuclear
Comisión Nacional de Energía Atómica
República Argentina

ABSTRACT

Uranium mining and milling development in Argentina started early in the 50's. Initial exploitation was carried out in underground mines, but, since 1978, open pit mining is the main production process. Environmental monitoring in the vicinity of uranium mills is performed on a routine basis. Natural uranium and radium-226 concentrations in surface waters are measured in grab samples taken at selected points up stream and down stream, in the area of influence of the mining and milling facilities. In addition, radon-222 emanation rates from ore tailings are measured. Up to date, no significant exposure results for the population living in the surrounding areas.

INTRODUCTION

Uranium industry began its development in Argentina in 1950. Since then, several installations have operated in uranium underground mining until the late 70's, when mines were closed and open pit exploitation was initiated. Milling plants were installed in the mining areas or nearby.

The waste sources at the mills include: a) barren acid liquors which have been stripped of uranium. These liquors were initially discharged to river waters. Nowadays, they are neutralized and piped to large evaporation and seepage ponds. When the evaporation process is not effective enough, the neutralized liquors are discharged to river waters after passing through small holding ponds; b) Ore tailings from the acid-leach process which are deposited at large tailing ponds located some distance from the milling plants and from the water bodies.

In order to assess the possibility of significant environmental contamination by uranium-mill wastes, routine studies of the dissolved radium-226 and natural uranium concentrations in surface waters up stream and down stream from the plants are being conducted. In addition, radon-222 emanation rates from ore tailings are measured at times.

ENVIRONMENTAL MONITORING PROGRAM

The uranium mining and milling areas included in the environmental monitoring program are the following: Don Otto, in the province of Salta; Los Adobes, in the province of Chubut; San Rafael and Malargüe, in the province of Mendoza; Los Gigantes, in

the province of Córdoba; and La Estela, in the province of San Luis. Figure 1 shows their geographical location.

Water samples are taken from river locations up stream and down stream from uranium mills, according to a special monitoring plan set up for each one of them. The period of exploitation, the annual production of "yellow-cake", the number of sampling points and the number of water samples for each installation are shown in Table 1.

As an example, Figure 2 presents the monitoring area corresponding to the vicinity of the San Rafael mining and milling plant. Water monitoring points are situated at about 10 km, 50 km and 80 km up stream and down stream from the plant. Samples are taken from rivers flowing through the surroundings of the mining and milling area, as well as from streams which they join afterwards. Samples from plant areas are also taken. The location of the sampling points allows the comparison of radium-226 and natural uranium concentrations above and below the plant, providing estimations of the extent and magnitude of water contamination, if there is any.

Dissolved radium-226 in water samples is analysed by the radon emanation technique, while natural uranium concentration is measured by fluorometric procedures [1]. Radon-222 emanation rate from ore tailings is determined by the technique described by Countess [2]. Since 1988, gross alpha counting, using ZnS(Ag) as a detector, is performed on water samples. Only those samples exceeding 70 mBq/l of gross alpha activity are selected for radium-226 analysis.

PRESENTATION OF DATA AND CONCLUSIONS

Figures 3 and 4 show the range of values of radium-226 and the maximum natural uranium concentrations measured in water samples from sampling points located at the San Rafael plant, since 1980. The corresponding ranges of values obtained for all uranium sites, compared with derived limits for drinking water applied in Argentina [3], are presented in Figures 5 and 6. Results before 1980 present a similar pattern [4].

Table 2 shows the radon-222 emanation rates measured at each location. A preliminary evaluation of these results has been presented previously [5].

The application of the statistical test of Wilcoxon [6] demonstrated that no significant difference in the radium-226 and natural uranium concentrations was found between the surface water samples from river locations above and below the milling plants. Besides, the results obtained are well below the derived limits for drinking water. Therefore, it may be concluded that no remarkable exposure occurs for the population living in the vicinity of these areas.

REFERENCES

1. Environmental Measurements Laboratory, Procedures Manual, 1990, 27th. Edition, Vbl. 1.
2. Countess, R.J., 1976, Rn-222 Flux Measurement with a Charcoal Canister, Health Phys., 31, 455.
3. C.N.E.A., 1966, Normas Básicas de Seguridad Radiológica y Nuclear.
4. C.N.E.A., Sección Radiactividad Ambiental, Informes Internos.
5. Ciallella, H.F. et al., 1988, Radon Emanation Measurements from Uranium Ore Tailings in Argentina, 7th. Int. Congress of I.R.F.A., Sydney, Vol. 1, 373-376.
6. Conover, W.J., Practical Non Parametric Statistics, 1985, Edited By J. Wiley & Sons, 215-216.

TABLE 1

Mining and/or Milling sites	Exploitation period (year)	Average annual production of yellow-cake (tons)	Sample points	Number of samples (Ra226+U)
Don Otto	1955-1981	23	45	95
Los Adobes	1977-1981	25	28	110
San Rafael	1980-1990	57	24	200
Malargue	1955-1986	50	33	120
Los Gigantes	1982-1990	25	17	170
La Estela	1982-1991	4	16	100

TABLE 2

Mining and/or Milling sites	Period (year)	Emanation rate (Bq/m ² .s)
Don Otto	1984-1985	20-43
Los Adobes	1984-1986	3-8
San Rafael	1983-1986	8-12
Malargue	1984-1987	6-12
Los Gigantes	1985-1986	<1
La Estela	1986	11

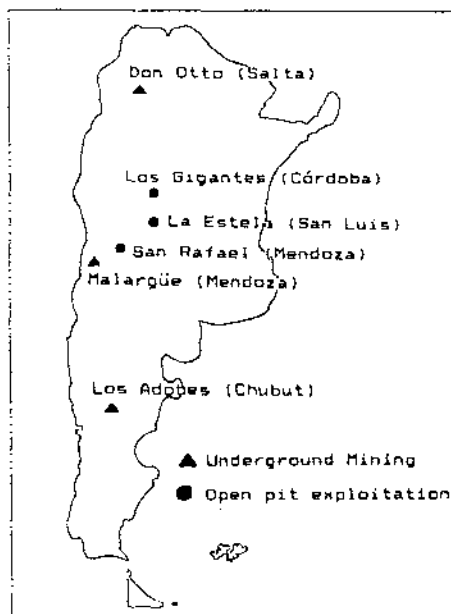

FIGURE 1: Uranium mining and milling sites in Argentina.

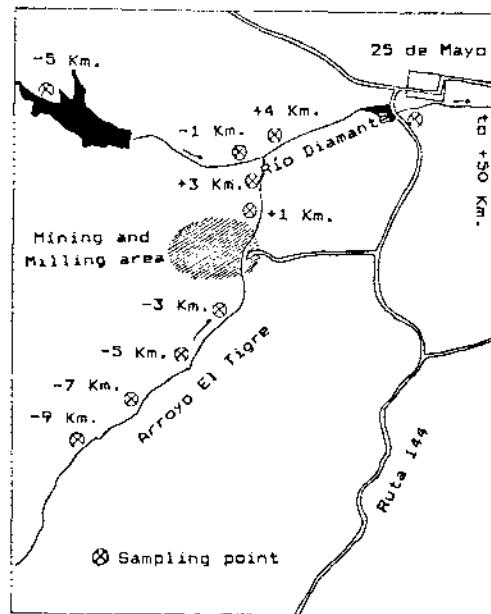

FIGURE 2: San Rafael (Mendoza). Uranium mining and milling area. Sampling points.

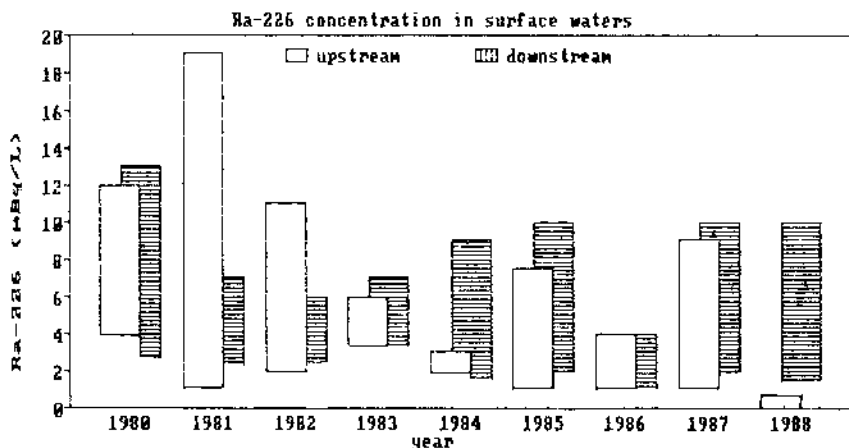

Figure 3: Range of values ((10 Km. upstream and (50 Km. downstream from the discharge point) in San Rafael plant (Mendoza)

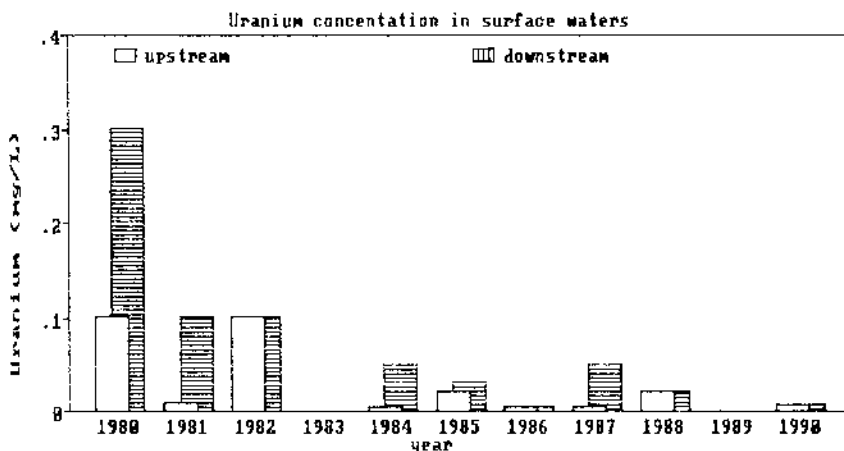

Figure 4: Maximum values measured ((10 Km. upstream and (50 Km. downstream from the discharge point) in San Rafael plant (Mendoza)

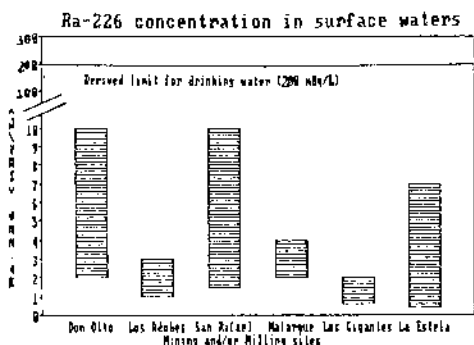

Figure 5: Range of values downstream ((50 Km. from the discharge point) for the last year assessed

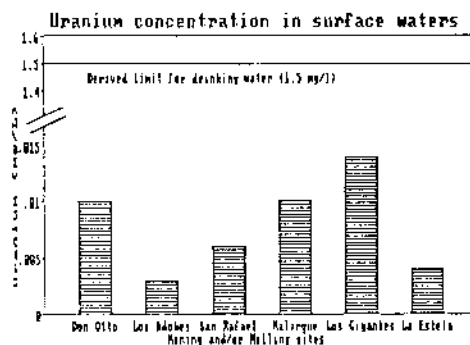

Figure 6: Maximum values measured downstream ((50 Km. from the discharge point) for the last year assessed

Measuring Network for Environmental Monitoring in Europe: State of the Measuring Technique

Dr. E. Frenzel
EG&G Berthold, Wildbad, Germany

Environmental monitoring of the radioactivity has gained a high priority in Europe in recent years. Today, the local dose rate and air-borne particulate and iodine activity concentrations are monitored fully automatically by measuring networks covering entire regions.

Introduction

In recent years, the large-area immission monitoring of radioactivity in the air has gained a high priority. One reason is certainly the increased awareness concerning environmental issues; moreover, laws exist in several European countries, passed as a consequence of the nuclear accident at Chernobyl, which stipulate the requirements for such a monitoring system.

Since radioactivity is transported very rapidly through the air, special emphasis will be paid to monitoring this medium in large-area contamination situations. The necessary fully automatic monitoring of the environmental radioactivity requires measuring networks covering large areas with stations which record all essential radiological parameters on-line and automatically. The instruments employed in these networks should correspond to the state of the art in science and technology in order to detect very low artificial air-borne activity concentrations within a very short time, with absolute reliability and without requiring any maintenance, to analyze them and to transmit them to the central data station via remote data facilities.

Of special importance is the automatic nuclide identification by high-resolution γ -spectroscopy. The type of accident and its development can be deduced from the nuclide composition; moreover, any information on the nuclide composition is absolutely essential for an accurate and detailed estimation of the dose, because different nuclides yield different doses.

To detect any air contamination as early as possible to be able to respond accordingly and to assess the actual situation and the resulting dose, the following radiological quantities have to be determined in the air:

- local gamma dose rate
- airborne particulate activity concentrations
- iodine activity concentrations

Local Dose rate Measurement

The local dose rate measurement is a non-nuclide-specific method. Together with nuclide-specific measuring methods, it provides complete information on the contamination situation. Local dose rate measurements are an excellent method of providing information covering large areas.

The detectors employed in this measuring networks are energy-filtered and measure gamma energies down to below 50 keV. With regard to sensitivity, these detectors are capable of detecting variations of a few nSv/h in a 2-hour measuring cycle with a high statistical safety. Modern detectors are moreover equipped with an "at-site electronics" which often includes the appropriate interfaces for data transfer.

The detectors are essentially energy-filtered Geiger-Müller counter tubes or proportional counter tubes. In order to cover the required measuring ranges - up to 5 Sv/h - one has to use two detector systems (low and high dose range).

Due to its physical properties, proportional counter tubes offer the best conditions for the use in local dose-rate measurements (low inherent background, sensitive at low energies, short deadtime). In praxis, the slightly less sensitive Geiger-Müller counter tubes are often preferred, due to their less sophisticated electronics and their lower price, so that proportional counter tubes are hardly used these days in large-area measuring networks.

Particulate Measurement

The measurement of air-borne particulate activity concentrations is quite difficult for several reasons. On the one hand, the artificial activity concentrations to be detected are significantly lower than the fluctuating natural activity concentrations; on the other hand, the levels of this air-borne particulate activity concentration are so low that only accumulation methods can be used.

Using powerful pumps (up to 70 m³/h), the air is aspirated through glass fiber filter to accumulate the radioactive aerosols. Depending on the measuring task, a detector is installed above the dusting location, either a zinc-sulphide coated plastic scintillation counter, or a highest grade germanium detector.

Moving filter facilities allowing automatic operation of the moving filter up to half a year are particularly suited for the use in measuring networks.

Although measuring methods according to the alpha-beta ratio method detect only total artificial beta, or when using the pseudocoincidence difference method, total artificial alpha, this method is still being used because it is the only method which permits the detection of nuclide groups which have no gamma transitions, and the fastest for the detection of contamination in the air.

Nuclide-specific identifications with highest grade germanium detectors, fully automatic evaluation software and, if necessary, remote data transfer facilities, are today's state of the art of science and technology. The measuring instrument of the first generation used rather complicated and problem-oriented programming languages; today's trend is clearly to use commercial languages available on the market running on standard PC's.

Nuclide-specific measuring systems, moreover, include an interface for remote data transfer and even allow the data transfer of spectra. To ensure an optimum early warning, these instruments are designed such as to allow the simultaneous alpha-beta measurement and the nuclide-specific measurement.

Iodine Measurement

Since iodine and thus radio-iodine as well is accumulated especially in the thyroid gland, this potential health hazard requires special efforts. Due to the fact that iodine and most of its combinations are very transient, special filters have to be used. Iodine occurs bound to aerosols as well as in a gaseous form. For gaseous iodine one uses special filters, such as silver-impregnated activated carbon. These filters which are particularly suited for gaseous iodine possess, unfortunately, a low retaining capability for aerosol-bound iodine.

If both iodine species are bound to one absorber, one uses special absorbers, such as AC 6120; the consequence will be, however, that filter and detector have to be heated up to avoid that the temperature drops below the condensation level. By combining a particulate monitor and an iodine monitor for gaseous iodine one will be able to detect both species.

In the iodine monitor, the iodine is concentrated in a cartridge which includes the respective absorber. The iodine cartridge surrounds the detector either as a Marinelli container, or it is located directly next to the detector. Usually, the 364-KeV line of the master nuclide ¹³¹Iodine is detected by means of a NaI-detector. Today, one can measure ¹³¹Iodine activity concentrations up to several 100 mBq/m³ per hour with high statistical safety.

Specifications for Automatic Network Operation

The instruments must feature a high level of operational safety. This means that they have to be immune to mechanical trouble; on the other hand, power supply fluctuations and peaks should be filtered such that the usual network operation will not be affected. Also, the instruments must include self-monitoring devices to ensure their proper and safe operation.

Air flow rates have to be measured; detectors have to be monitored with regard to their thresholds and high-voltage, moving filters must be equipped with torn filter facilities. In addition, the instruments used must be secured as far as possible against unauthorized operation and incorrect operation. Since many of these measuring systems are combined in measuring networks, the question if remote control is provided is also important, particularly the repeat tests performed by the central station.

In addition to the communication with the central station, the instruments at site must be capable of operating autonomously in the event the data transfer breaks down, so that all essential and relevant data will be saved on a suitable data carrier for at least a short time.

Conclusions

Today, low level results of some mBq/m³ are available within several hours. In addition, the measuring technique of 1991 even permits to identify nuclides or to classify nuclide groups according to the type of radiation (alpha or beta).

For several years now, automatic measuring systems are available for the immission measurement of radio-iodine in the environmental air. Certainly, in future the germanium detector will replace the NaI-detector, as this is the only way to selectively detect different iodine nuclides.

Automatic measuring networks for environmental monitoring exist in many European countries, for example, Germany, Spain, the Netherlands, Switzerland and others. The measuring network differ in details; however, nearly all networks measure the local gamma dose rate, the concentration of radioactive aerosols and radio-iodine in the air.



Fig. 1 shows a typical instrument for measuring α/β and γ emitting nuclides, including an iodine measuring system.

References

1. H. Völkle, E. Frenzel, K. Heinemann, A. Neu, J. Steiner, R. Winkler: Verfahren zur Überwachung der Aerosolaktivität insbesondere durch nuklid-spezifische On Line Messungen; Bericht einer Ad-Hoc-Arbeitsgruppe des AKU des Fachverbandes Strahlenschutz, 1989; in Vorbereitung für die Loseblattsammlung
2. R. Maushart: Meßnetze zur Überwachung der Umweltradioaktivität in den europäischen Ländern - so unterschiedlich wie die Völker?; 8. Fachgespräch zur Überwachung der Umweltradioaktivität, Berlin, 24. bis 26. Oktober 1990
3. M. Zähringer, P. Bieringer, B. Kromer, H. Sartorius, W. Weiss: Entwicklung, Erprobung und Einsatz von Schnellmethoden zur nuklid-spezifischen Bestimmung atmosphärischer Kontaminationen; IAR-1/90 Bericht des Bundesamtes für Strahlenschutz, Fachbereich Strahlenschutz, Institut für Atmosphärische Radioaktivität, Dienststelle Freiburg, Rosastraße 9, 7800 Freiburg; ISSN: 0937-8677
4. W. Weiss: The Importance of Automatic Immission Measuring Networks for Radiation Protection Purposes; published by: Summerschool Radiation Protection, June 10 - 15, 1991, Berlin, Germany.

THE DETERMINATION OF RADIUM, URANIUM AND THORIUM IN LOW SPECIFIC ACTIVITY SCALES AND IN WATERS OF SOME OIL AND GAS PRODUCTION PLANTS

C. Testa, D. Desideri, M.A. Meli, C. Roselli
(General Chemistry Institute, Urbino University, Italy)
A. Bassignani, P.B. Finazzi
(Radiation Protection Institute, AGIP, Milan)

Abstract

Low specific activity scales consisting of alkaline earth metal carbonates and sulphates are often present in some gaseous and liquid hydrocarbon plants; these scales contain a certain concentration of radium, uranium and thorium which can cause a risk of gamma irradiation and internal radiocontamination when they must be mechanically removed. ^{238}U , ^{232}Th and ^{226}Ra were determined in scales, sludges and waters coming from different plants. ^{238}U and ^{232}Th concentrations were found very low; the isotopes ^{238}U and ^{234}U resulted in secular radioactive equilibrium, ^{232}Th and ^{228}Th were not always in equilibrium. ^{226}Ra concentration resulted to be higher in the scales and sludges than in waters.

Introduction

Naturally occurring radioactive materials are known to be present in different concentrations in oil and gas production plants giving rise to the so called Low Specific Activity (L.S.A.) scales (1-3).

The chemical composition of L.S.A. scales varies, consisting mainly of alkaline earth metal sulphates and calcium carbonates incorporating small amounts of radium (1); uranium and thorium can also be present in some extent; the scales production is due to different causes: injection of incompatible waters (75%), evaporation in gaseous wells (10%), pressure changes (10%), temperature drops (5%) (4-6).

L.S.A. scales invariably emit alpha and beta particles and gamma rays (7); their presence in production plants can give rise to a gamma irradiation risk to the staff remaining for a long time in some particular plant areas and to a possible risk of internal radiocontamination to the staff involved in the scales or sludges mechanical removal and disposal.

That being stated a programme was started to determine uranium, thorium and radium in the scales, sludges and waters coming from Italy, Northern Sea and Africa.

Radioanalytical methods

The used radiochemical analysis was as follows. After the sample dissolution, ^{232}U and ^{228}Th were added as yield standards; the residue was dissolved in 2 M HNO_3 and the solution passed through a small column of Microthene (microporous polyethylene) 50-100 mesh supporting tri-octylphosphine oxide (TOPO); thorium was eluted with 1 M HCl and uranium with 1 M $(\text{NH}_4)_2\text{CO}_3$. After electroplating from $(\text{NH}_4)_2\text{SO}_4$, uranium and thorium alpha emitters were detected by alpha spectrometry. ^{226}Ra was determined by

counting Ba(Ra)SO₄ with a ZnS(Ag) detector after its separation from uranium and thorium and the decay of ²²⁴Ra (8). This technique was preferred to gamma spectrometry because of the presence of radioactive disequilibria in the ²³⁸U and ²³²Th families and taking into account the low activity to be measured.

Results and discussion

Taking into account the results shown in the tables I-III, the following conclusions can be drawn:

- 1) ²³⁸U and ²³²Th concentrations are either not detectable or very low ;
- 2) ²²⁶Ra concentration seems to be higher in oil extraction plants (800-3000 Bq/kg) than in other plants (30-400 Bq/kg), ²²⁶Ra concentration in the waters is very low because of its chemical behaviour;
- 3) for any specific plant, ²²⁶Ra concentration seems to be directly correlated to the extraction depth;
- 4) when uranium is detectable, the isotopes ²³⁸U and ²³⁴U are in secular radioactive equilibrium (Fig.1);
- 5) ²³²Th and ²²⁸Th are not always in equilibrium, especially in Tunisian scales, where the ratio ²²⁸Th/²³²Th can reach very high values, up to 700 (Fig.2). This fact can be due to the presence of initially high concentrations of the father ²³²Th from which ²²⁸Ra separated because of the different chemical behaviour of the two elements. Consequently the internal contamination risks could be caused not only by ²²⁶Ra, but also by ²²⁸Th and its daughters (²²⁴Ra, ²¹²Pb, ²²⁰Rn, ²¹⁶Po, ²¹²Po).

References

1. E & P Forum : "Low Specific Activity Scale origin, treatment and disposal", Report No 6.6/127, January 1988.
2. Mohammed Ibrahim El-Hattab : "Scale Deposition in Surface and Subsurface Production Equipment in the Gulf of Suez", Journal of Petroleum Technology, 1640-1652, September 1985.
3. O.J.Vetter : "Oilfield Scale - Can We Handle it?", Journal of Petroleum Technology, 1420-1408, December 1976.
4. J.Shen, C.C.Crosby : "Insight Into Strontium and Calcium Sulfate Scaling Mechanism in a Wet Producer", Journal of Petroleum Technology, 1249-1255, July 1983.
5. O.J.Vetter, R.C.Phillips : "Prediction of Deposition of Calcium Sulfate Scale Under Down-Hole Conditions", Journal of Petroleum Technology, 1299-1308, October 1970.
6. O.J.Vetter, V.Kandarpa, A.Harouaka : "Prediction of Scale Problems Due to Injection of Incompatible Waters", Journal of Petroleum Technology, 273-284, February 1982.
7. A.L.Smith : "Radioactive Scale Formation", Offshore Technology Conference, Houston, May 6-9, 1985.
8. C.Testa, D.Desideri, M.A.Meli, S.Bazzarri : "Separation and determination of uranium and radium-226 in phosphorites and their industrial derivatives by Extraction Chromatography", Journal of Radioanalytical and Nuclear Chemistry, 129/1, 191, 1989.

Tab.I: ^{238}U , ^{232}Th and ^{226}Ra concentration in different kinds of scale.

PLANT FEATURES	EXTRACTED HYDROCARBON	DEPTH (km)	CONCENTRATION (Bq/kg)		
			^{238}U	^{232}Th	^{226}Ra
EXTRACTION PLANT (PO VALLEY)	LIQUID	6	<0.9	<0.8	2870±578
EXTRACTION PLANT (PO VALLEY)	LIQUID	5	<0.9	<0.8	1126±223
EXTRACTION PLANT (PO VALLEY)	MIXED	5	<0.9	<0.8	120± 24
COLLECTION PLANT (PO VALLEY)	GASEOUS	-	23.8± 4.3	18.9±3.8	30± 6
COLLECTION PLANT (PO VALLEY)	GASEOUS	-	53.8±0.8	<0.8	<2.7
COLLECTION PLANT (SOUTHERN ITALY)	LIQUID	-	11.3± 2.3	<0.8	110± 22
OFF SHORE PLATFORM (NORTHERN SEA)	LIQUID	3	<0.9	<0.8	780±156
EXTRACTION PLANT (TUNISIA)	LIQUID	1	<0.9	<0.8	1323±265
TREATMENT PLANT (TUNISIA)	LIQUID	1	<0.9	<0.8	35± 7
PHASE SEPARATION PLANT (TUNISIA)	LIQUID	1	7.3±1.4	8.1±1.6	72± 15

Tab.II: ^{238}U , ^{232}Th and ^{226}Ra concentration in sludges.

PLANT FEATURES	EXTRACTED HYDROCARBON	DEPTH (km)	CONCENTRATION (Bq/kg)		
			^{238}U	^{232}Th	^{226}Ra
TREATMENT PLANT (TUNISIA)	LIQUID	1	4.6±0.9	13.0±2.6	69± 14
TREATMENT PLANT (TUNISIA)	LIQUID	1	10.3±2.1	33.0±6.6	175± 35
TREATMENT PLANT (TUNISIA)	LIQUID	1	6.7±1.3	2.6±0.5	393± 79

Tab.III: ^{238}U , ^{232}Th and ^{226}Ra concentration in waters.

PLANT FEATURES	EXTRACTED HYDROCARBON	DEPTH (km)	CONCENTRATION (Bq/kg)		
			^{238}U	^{232}Th	^{226}Ra
EXTRACTION PLANT (PO VALLEY)	MIXED	5	$<4.5 \text{ E-}3$	$<4.0 \text{ E-}3$	$20 \text{ E-}1 \pm 4.0$
EXTRACTION PLANT (PO VALLEY)	LIQUID	2	$1.5 \text{ E-}2 \pm 3.0 \text{ E-}3$	$<4.0 \text{ E-}3$	$2.3 \text{ E-}1 \pm 4.6 \text{ E-}2$
OFF SHORE PLATFORM (ADRIATICO SEA)	GASFOUS	1	$7.3 \text{ E-}3 \pm 1.5 \text{ E-}3$	$<4.0 \text{ E-}3$	$6.0 \text{ E-}2 \pm 1.2 \text{ E-}2$

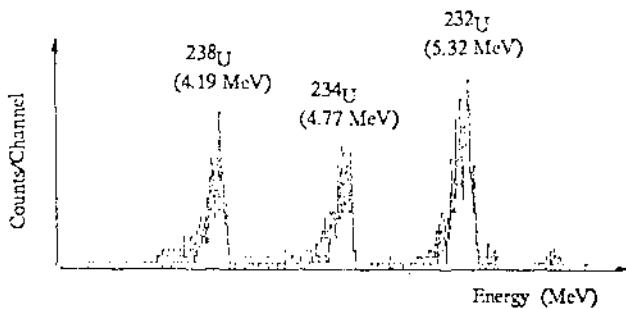

Fig.1:Uranium alpha spectrum

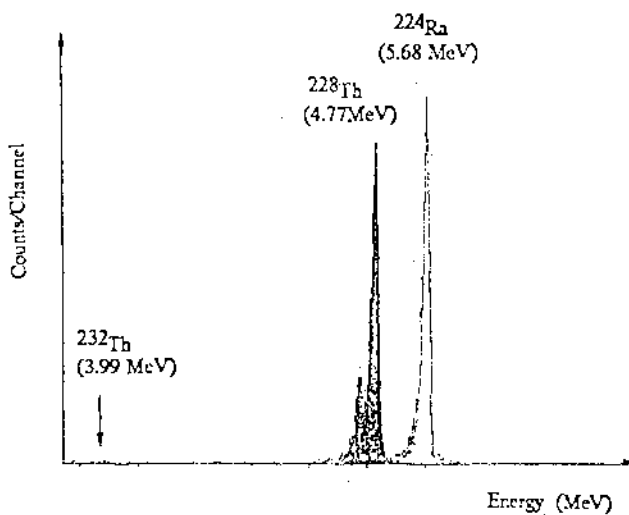

Fig.2:Thorium alpha spectrum

OBSERVATION OF TRITIUM BY CONTINUOUS SAMPLING
OF RAIN AND WATER VAPOR IN OSAKA

T.Matsunami*, T.Ishiyama*, K.Megumi* and S.Kimura**

- * Research Institute for Advanced Science and Technology,
University of Osaka Prefecture, Sakai-shi, Osaka, Japan
- ** Osaka University of Pharmaceutical Science, Matsubara-
shi, Osaka, Japan

ABSTRACT

As the results of environmental activity observation for three years made in the vicinity of a facility handling tritium and in an urban station 11km distant from the facility, it was assumed that the tritium concentration ratio of atmospheric water vapor to rain water could be an index to find out very slight release of tritium from a facility handling tritium. In the observation period the influence of Chernobyl accident was detected and rise of tritium concentration in rain water was observed when high concentration of loess aerosol visited Japan.

INTRODUCTION

The main chemical form of tritium in the environment is HTO, so the discharged ^3H enters the water cycle in the environment¹⁾. Monthly tritium activity in rain water was measured for three years in the vicinity of a facility handling tritium (Sakai) and in an urban station 11km distant from the facility (Tondabayashi), together with ^{137}Cs , ^{134}Cs and ^7Be activities. Monthly tritium activity in atmospheric water vapor was also measured for two years and half in Sakai, together with atmospheric activity concentrations of ^{137}Cs , ^{134}Cs and ^7Be . The results of observation are discussed in connection with Chernobyl accident, the visit of loess aerosol from the continent and the possibility of detection of very slight tritium release from a facility handling tritium.

METHODS OF SAMPLING AND MEASUREMENT

Monthly rain water sample was collected with funnel sampler of 490cm^2 in collecting area. 0.5 l was used for tritium measurement, and the rest was evaporated to dryness and used for gamma-ray spectrometry with a Ge(Li) detector.

Atmospheric water vapor sample was collected by passing air through molecular sieves 4A packed in a glass column (50x320 mm) continuously for about one week at a rate of 3 l/min and absorbing water vapor in the column. Four samples were collected in a month.

Airborne dust sample was collected by passing air through a Millipore AA filter with a low volume air sampler continuously for a month and subjected to gamma-ray spectrometry with a Ge(Li) detector²⁾.

Dry nitrogen gas was passed through the molecular sieves heated to 450°C and a cold trap, and usually 50-70ml of water was collected in the trap. Monthly water samples (rain water

samples and water samples released from the molecular sieves) were purified through distillation and 200-250ml was subjected to tritium concentration by multi-electrode electrolysis³⁾.

Tritium activity measurement was made with a low background liquid scintillation counter (Aloka LB-1, TRI-CARB 2250CA), the measuring time being 1000 min.

RESULTS AND DISCUSSION

1. Variation with time in tritium concentration in rain water

In Fig.1 are shown variations with time of monthly concentrations in rain water of ^3H , ^{137}Cs , ^{134}Cs and ^7Be (Bq/l) and monthly rainfall (mm) which were observed at two stations, namely, in the vicinity of a facility handling tritium (Sakai) and in the yard of a house in an urban station about 11 km distant from the facility (Tondabayashi) for three years from January 1986 to December 1988. Correlation coefficients between these monthly observed values obtained at Sakai and Tondabayashi were calculated and are shown in Table 1.

The ranges of variation in the tritium concentrations were 0.3-6.6 Bq/l for Sakai (average: 1.6 Bq/l) and 0.1-4.3 Bq/l for Tondabayashi (average: 0.7 Bq/l). The average tritium concentration was about twice larger in Sakai than in Tondabayashi. The correlation coefficient obtained for the tritium concentration was somewhat smaller than those obtained for the ^{137}Cs , ^{134}Cs and ^7Be concentrations and the rainfalls. Thus, it appears that the difference between the tritium concentrations in rain water observed at Sakai and at Tondabayashi is ascribed to very slight release of tritium from the facility handling tritium in Sakai.

As shown in Fig.1 relatively high concentrations of ^{137}Cs , ^{134}Cs and ^3H were observed in April and May 1986, resulting from the Chernobyl accident of 26 April 1986. (Fresh nuclear debris were detected in rain water 6 May for the first time.)

As apparently seen in Fig.1, conspicuously high tritium concentrations were observed in April (and May) 1988, namely, 6.6 ± 0.4 Bq/l at Sakai and 4.3 ± 0.4 Bq/l at Tondabayashi. It is noticed that ^{137}Cs concentration was also high in April 1988, coinciding with the appearance of high tritium concentration. It is generally accepted that tritium concentration in rain water is lower for ocean-originating rainfall while it is higher for continent-originating rainfall. It is well known in Japan that in 19-23 April 1988 the sky over west Japan was covered with very high concentration of loess aerosol. At that time continental high atmosphere was quite dominant over west Japan. It is also generally recognized that in the time of the year when high concentrations of loess aerosol are observed in Japan, agitation occurs in high atmosphere over Asiatic continent. It is assumed that the air agitation causes descending of old nuclear debris such as ^{137}Cs and ^3H from the high atmosphere, and these old nuclear debris travels with loess aerosol to Japan and then comes into rain water. A small peak of tritium concentration appearing in April 1987 might be also ascribed to visit of loess aerosol.

2. Variation with time of tritium concentration in atmospheric

water vapor

In Fig.2 are shown variations with time of monthly atmospheric concentration of tritium contained in water vapor (mBq/m³) and humidity (g/m³) together with monthly tritium concentration in water released from molecular sieves (Bq/l), namely, monthly tritium concentration in water vapor, which were observed at Sakai in the period from August 1986 to December 1988. The monthly humidity was higher in summer and lower in winter, and correlates relatively well with the monthly atmospheric tritium concentration.

In fig.3 are shown variation with time of atmospheric concentrations of ¹³⁷Cs, ¹³⁴Cs, ⁷Be and airborne dust.

3. Tritium concentration ratio of atmospheric water vapor to rain water

In Fig.4 are shown variation with time of the ratio of monthly tritium concentration in atmospheric water vapor (unit: Bq/l) to that in rain water (unit: Bq/l), which was observed at Sakai in the period from August 1986 to December 1988. The ratio is higher in the period from August 1986 to February 1987 and from August 1988 to December 1988 compared to other periods. Tritium handling was carried out more frequently in the facility in the periods showing high ratio values, and thus it is assumed that the ratio could be used as an index to detect very slight release of tritium from a facility handling tritium, discriminating from global tritium (natural and artificial). For instance, when the ratio is higher than 2, it may be suspected that slight local release of tritium exists. However, it should be remarked that the index value may become much smaller than 2 when less aerosol visits Japan resulting in increase in tritium concentration in rain water. The tritium concentration in atmospheric water vapor is considered to depend more strongly on local origins than that in rain water.

REFERENCES

1. Shinohara, K., Watanabe, H., Nomura, T. and Yamato, A., 1983, Measurement of Atmospheric Tritium and Estimation of Dose Equivalent, Hokenbutsuri, 18, 231-236.
2. Matsunami, T., Mizohata, A. and Mamuro, T., 1979, Observation of Depositions and Atmospheric Concentrations, Ann. Rept. Rad. ctr. Osaka., 20, 1-4.
3. Kimura, S., 1988, Improvement of Tritium Enrichment Electrolysis Cell for Environmental Monitoring, Proceedings of IRPA 7, 2, 540-543.

Table 1 Correlation coefficients calculated between the concentrations at Sakai and at Tondabayashi of radionuclides, rainfall.

Nuclide	Correlation coefficient
³ H	0.71
⁷ Be	0.82
¹³⁴ Cs	~0.8
¹³⁷ Cs	0.84
Rainfall	0.90

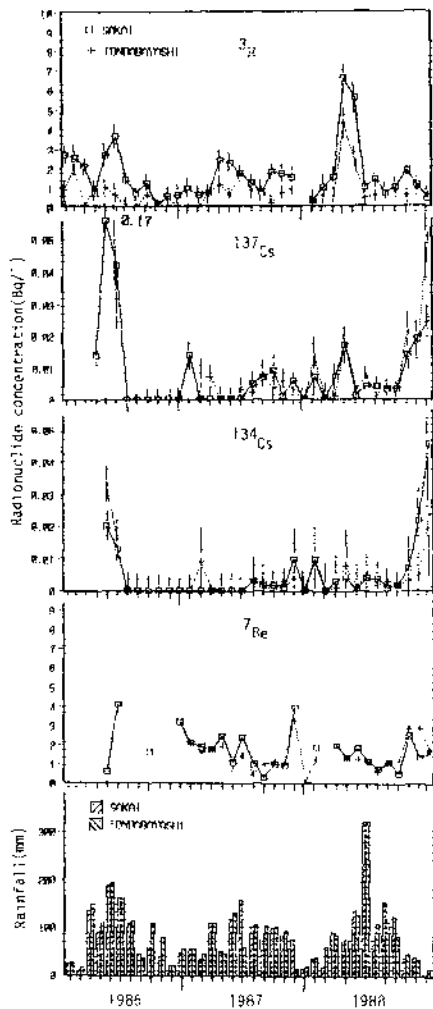

Fig. 1 Variation with time of monthly concentrations ^3H , ^{137}Cs , ^{134}Cs , ^7Be and monthly rainfalls, observed at Sakai and at Tondabayashi.

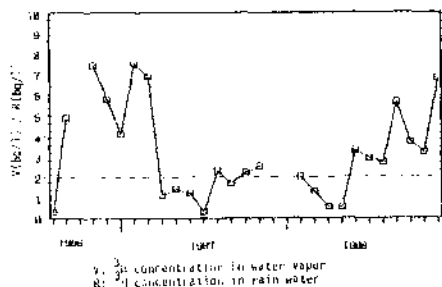

Fig. 4 The ratio of tritium concentration in water vapor to rain water at Sakai.

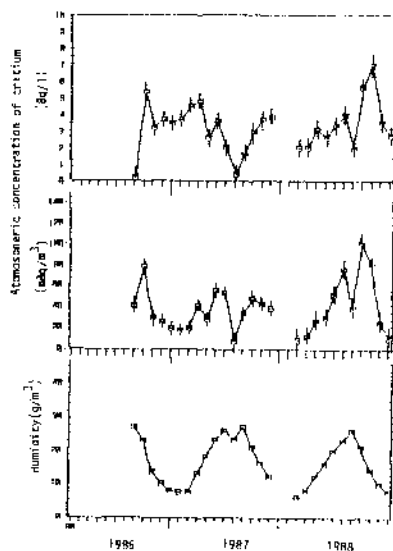

Fig. 2 Variation with time of monthly average atmospheric concentration of HTO and humidity observed at Sakai.

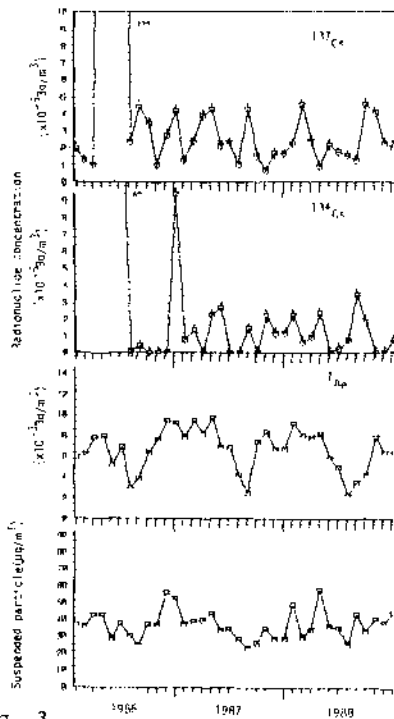

Fig. 3 Variations with time of monthly average atmospheric concentration of ^{137}Cs , ^{134}Cs , ^7Be and total suspended particles observed at Sakai.

SURVEILLANCE DE L'ENVIRONNEMENT DE LA HAGUE

S. LE BAR, Chef de la Section Prévention-Evaluation
du Service de Prévention et Radioprotection
de l'Etablissement COGEMA LA HAGUE

ENVIRONMENT CONTROL AT FUEL REPROCESSING PLANT COGEMA LA HAGUE

The control of the environment at LA HAGUE is very important because a good survey permits to know the impact of the plant activity on the environment. With many measurements, with various methods, this target is reached. The results over the last ten years show this impact has been divided by three while the amount of reprocessed spent fuel was multiplied by four.

1 PRESENTATION

Etudiée et construite pour le retraitement des combustibles irradiés, l'usine de La Hague a actuellement une capacité d'exploitation de 1 200 T/an. Cette capacité sera portée à 1 600 T/an en 1994.

Un des principaux soucis des exploitants nucléaires est de veiller à l'application des règles de radioprotection et particulièrement de maîtriser les problèmes liés à l'environnement.

2 CADRE REGLEMENTAIRE

Avant la mise en actif d'une installation nucléaire industrielle, il est nécessaire d'étudier attentivement l'impact de son fonctionnement sur le milieu environnant et plus particulièrement sur la population.

Cette étude porte sur les conséquences sanitaires d'un fonctionnement normal de l'usine ainsi qu'en cas d'accident. Elle permet de définir une réglementation publiée au Journal Officiel de la République Française qui indique les limites de rejet à respecter en tout état de cause.

Ces autorisations portent sur les deux types de rejets effectués : liquides et gazeux. Pour chacune de ces autorisations, quatre limites d'activité sont à respecter :

rejets liquides : tritium, émetteurs bêta (hors tritium), strontium 90 et césium 137, émetteurs alpha.

rejets gazeux : gaz autres que le tritium, tritium, halogènes, aérosols.

Le respect de ces autorisations est contrôlé par un organisme ministériel, le Service Central de Protection contre les Rayonnements Ionisants (SCPRI) dépendant du Ministère de la Santé.

Enfin, l'application de ces prescriptions est vérifiée par une surveillance radiologique du site et de son environnement. Tous les résultats des mesures radiologiques retraçant l'évolution du milieu environnant sont transmis pour contrôle au SCPRI.

3 ORGANISATION DE LA SURVEILLANCE

Les moyens de surveillance et de contrôle peuvent se diviser en deux catégories différentes du point de vue de leur exploitation :

- la surveillance en continu qui permet en cas d'évolution d'un paramètre, d'engager rapidement les actions correctives. Le grand nombre

de ces mesures a nécessité une centralisation à un poste de contrôle centralisé (PC environnement).

- la surveillance en différé qui permet au moyen de prises d'échantillons dans l'environnement et d'analyses en laboratoire, de compléter notre surveillance et nos bilans.

3.1 SURVEILLANCE EN CONTINU

Ce contrôle s'exerce sur les rejets gazeux, les réseaux gravitaires et les paramètres météorologiques.

Rejets gazeux :

La surveillance en continu des rejets gazeux de l'Etablissement est conçue comme une série de trois cercles concentriques centrés sur l'Etablissement.

Au centre, les cheminées principales : UP 2 - UP 2 800 et UP 3. Les mesures effectuées sont de type alpha, bêta, gaz et mesure de débit.

Le deuxième cercle est constitué de huit stations de surveillance disposées en périphérie de l'Etablissement, elles permettent de décider si une anomalie peut avoir des répercussions à l'extérieur de l'usine. Les mesures effectuées portent sur la radioactivité des aérosols ainsi que sur l'irradiation ambiante.

Enfin, le troisième cercle est réalisé par cinq stations installées dans les villages avoisinants à des distances de 1 à 5 kilomètres, les mesures en temps réel portent sur l'activité des gaz et l'irradiation.

Gravitaires :

Toutes les eaux transitant sur l'Etablissement font l'objet d'un contrôle avant leur déversement dans le milieu avoisinant. Ce contrôle est effectué à l'aide de 5 contrôleurs bêta sur nappe d'eau (COBENADF). Le débit d'écoulement est mesuré en continu et enfin des analyses chimiques complémentaires sont effectuées.

Paramètres météorologiques :

Les mesures météorologiques doivent permettre d'évaluer les transferts atmosphériques de rejet d'effluents radioactifs gazeux en fonctionnement normal ou en situation accidentelle. L'Etablissement de La Hague s'est doté d'une station météorologique sur le site.

Poste de contrôle centralisé :

Une centralisation du résultat de ces contrôles a été réalisée pour permettre une vision plus générale et instantanée de la situation radiologique de l'Etablissement et de son environnement.

Chaque station de contrôle est équipée d'un automate qui permet d'élaborer et de restituer la mesure en local et de la transmettre au poste de contrôle centralisé de l'environnement (PCE). Le PCE est équipé d'un ordinateur central multitâches qui reçoit ses informations des différentes stations de mesure en continu et permet la restitution instantanée sur un écran vidéo couleur, l'impression des résultats et l'archivage.

3.2 SURVEILLANCE EN DIFFERE

Le contrôle différé consiste à prélever de façon systématique dans l'environnement des échantillons significatifs qui sont ensuite analysés par le laboratoire de l'environnement du service de Radioprotection. Cette surveillance préventive nous permet d'élaborer des bilans précis. Cette surveillance représente le prélèvement de 17 000 échantillons par an pour environ 50 000 analyses. Elle repose sur le contrôle des trois familles de transfert de la radioactivité vers la chaîne alimentaire ou biologique : transferts atmosphériques, hydrogéologiques ou marins.

Transfert atmosphérique :

L'ensemble des mesures constituant le contrôle continu en temps réel est complété par celles effectuées au moyen de filtres ou de pièges au charbon actif installés sur chacun des émissaires de l'Etablissement ainsi que sur les stations de clôture et périphériques.

De plus, cette surveillance est exercée sur les éventuelles retombées au sol : eaux de pluie, herbages, plantations, lait, viande.

Transfert hydrologique :

Les 32 sources ou ruisseaux prenant leur source à proximité de l'Etablissement sont surveillées et analysées. La nappe phréatique fait l'objet d'une surveillance particulière grâce à un réseau de 220 piézomètres. De plus, l'ensemble des eaux potables du district est analysé régulièrement.

Transfert marin :

Les rejets liquides de l'Etablissement se font en mer au travers d'une canalisation immergée de 6 km de long. Cette conduite de rejet fait l'objet d'une inspection régulière.

La surveillance cotière (200 km) s'exerce sur l'eau, le sable, les sédiments, les crustacés, les coquillages et les végétaux qui ont la particularité de fixer les radioéléments rejetés en mer. La surveillance de haute mer s'exerce sur l'eau, le sable, les sédiments et les poissons. Les prélèvements sont effectués de Granville jusqu'au Havre par la marine nationale française. Enfin, cette surveillance est complétée par l'étude de la diffusion marine des radioéléments en Manche et Mer du Nord effectuée par le Laboratoire de Radioécologie Marine du Commissariat à l'Energie Atomique (CEA).

4 RESULTATS

Ce programme de surveillance a l'agrément du Ministère de la Santé et fait l'objet de bilans. L'annexe 1 montre le bilan de la surveillance du milieu environnant pour les dix dernières années complétées par les mesures effectuées en 65 et 66 qui sont les années de référence précédant la mise en service de l'usine.

Les activités les plus élevées sont les plus anciennes et au fond du tableau et concernent la surveillance marine. On y observe une décroissance des activités pour les dix dernières années tandis que la quantité de combustible retraité n'a cessé de croître. Cette décroissance est le reflet de la diminution des activités rejetées en mer. De plus, on peut remarquer que depuis quelques années, l'activité artificielle est de même niveau que la radioactivité naturelle (potassium 40 et béryllium 7) pour les patelles et très inférieure pour les autres types d'échantillon.

Bilan des mesures dans l'environnement de la HAGUE

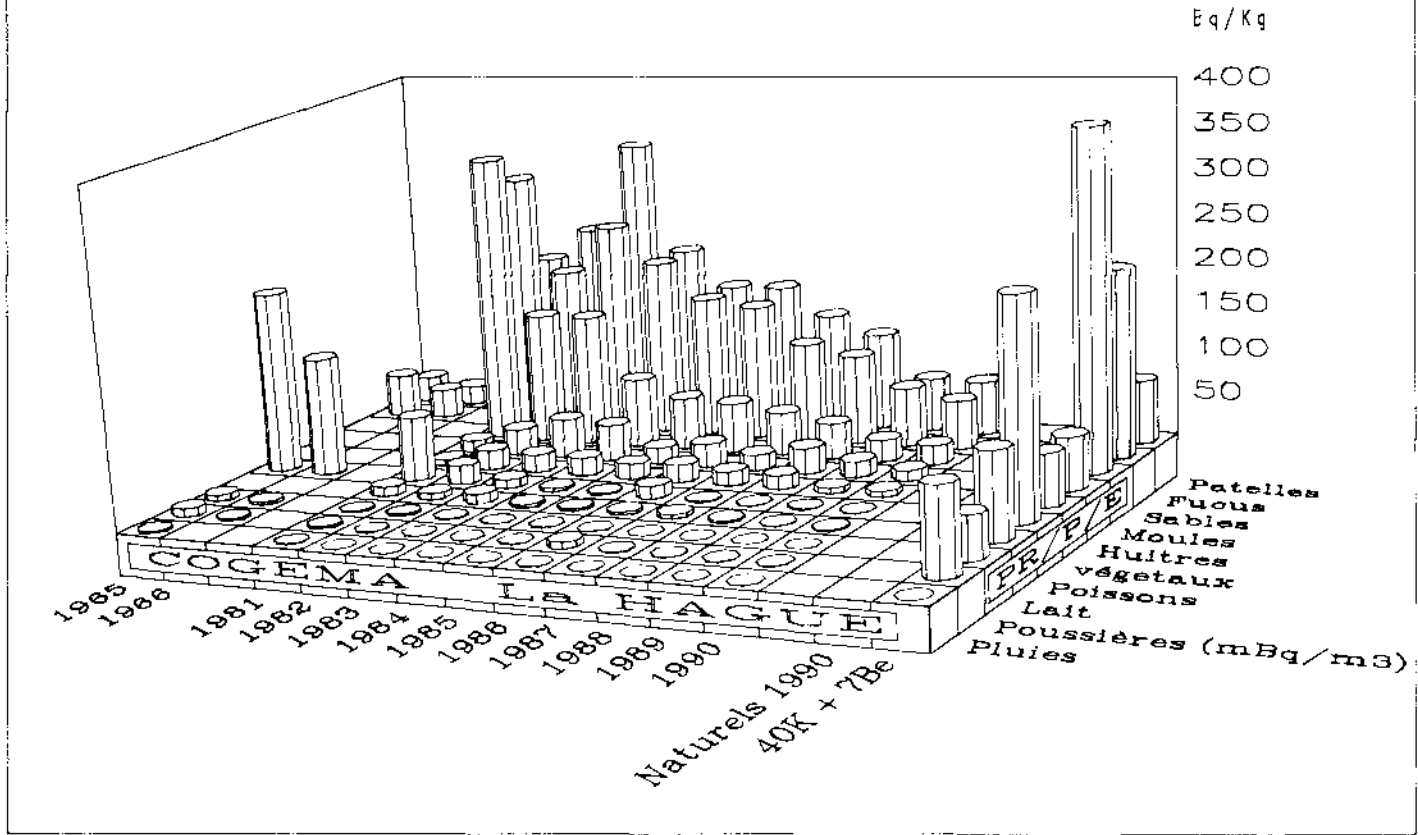

RADIOECOLOGICAL MONITORING OF THE ENVIRONMENT OF A FRENCH NUCLEAR POWER PLANT AFTER 12 YEARS IN OPERATION

DAUMAS J.*, FOULQUIER L.**, DESCAMPS B.**, ROUSSEL S.**

* Electricité de France - Centrale Nucléaire de Fessenheim

**Commissariat à l'Energie Atomique-IPSN/DPEI. Service d'études et recherches sur les transferts dans l'environnement.

SUMMARY

Taking Fessenheim Nuclear Power Plant as an example, description of various types of environmental test carried out under the responsibility of the Operator of Nuclear Power Plants in France : permanent monitoring of radioactivity, periodic radioecological assessments. Main results of measurements taken, showing the effect of the Plant to be negligible. Policy of openness by publication of these results.

INTRODUCTION

France has a large Nuclear Generating Capacity. The environment must be a constant concern, renewed according to scientific and technological progress. Observing strict regulations, Nuclear Power Plants release effluent, the radioactivity of which is added to radioactive fallout from old nuclear explosions and from Chernobyl. It is indispensable to monitor the surrounding radioecological state in order to ensure that operating these Plants is compatible with conservation. The Site of Fessenheim is given as an example of the various types of test carried out under the Operator's responsibility.

1. FESSENHEIM NUCLEAR POWER PLANT

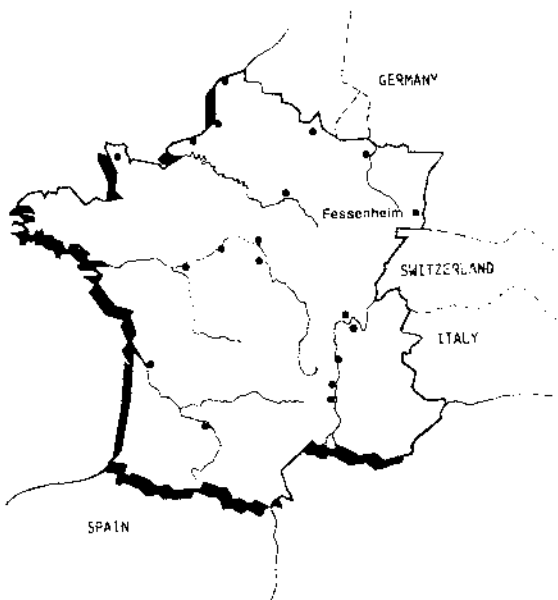

It is the oldest French 900 MW PWR Plant. It consists of two Units, connected to the grid in 1977. In France, there are currently 54 Units distributed over 19 sites.

The general process for radioecological studies consists of 4 phases :

- Initial radioecological assessment establishing a reference state.
- Permanent monitoring of radioactivity in the area surrounding the Plant.
- Complete radioecological assessment made after approximately 10 years in operation.
- Annual monitoring of main radio-indicators in the earth and aquatic ecosystems.

It is then possible to compare the results obtained with the effluent composition (table 1)

Table 1 : Overall composition of liquid and gaseous effluent released from Fessenheim Nuclear Power Plant.

	total β (GBq)	total α (GBq)	sum of RE* (GBq)	tritium (TBq)	volume ($10^3 m^3$)	Gas (TBq)	aerosols+halogens (GBq)
1985	37	157	82	30	57	93.5	0.12
1986	42	156	79	38	52	100	0.20
1987	27	69	42	36	48	44	0.11
1988	28	96	47	33	68	<12	<0.03
1989	23	81	46	24	59	<11	<0.03
1990	14	56	34	20	57	<8.3	<0.03
**		900		75		1500	110

* Sum of radioelements apart from H3, Ra, K40. These are basically : Co60+58 (about 80% of release), Ag 110m, Sb124, Tl31, Cs137+134. ** Annual authorized limit for site.

2. INITIAL RADIOECOLOGICAL ASSESSMENT

It is obligatory for the study of environmental impact as one of the conditions of the Request to Provide a Utility, before the first Unit is started up. It consists of two facets:

- Evaluation of dose, based on a series of measurements of dose equivalents in the region [1] and analyses of γ spectrometry inside living quarters [2]. Variations due to geology or man-made modifications are observed. In the Plain of Alsace, the results are from 0.66 to 0.96 mSv p.a with a supplementary contribution of between 0.26 and 0.61 mSv p.a, related to buildings. Occasional values are noted: 4.6 mSv p.a. on a farm near a heap of manure and 33 mSv p.a. near uranium-bearing lode.
- Measurements of radioactivity in the environment [3] mainly based, at this time, on soil, vines, corn, honey and tritium of water. The Plant has at its disposal [4] data concerning Rhine fish : the Cs137 content, attributable to radioactive fallout from nuclear tests, varied from 1 to 6 Bq.kg-1 (wet weight).

3. PERMANENT MONITORING OF RADIOACTIVITY

The measurements are carried out by the Operator (table 2) according to a statutory programme controlled by the Central Service for Protection against Ionizing Radiation (SCPRI), which is responsible to the Ministry of Health.

Table 2 : Measurements for monitoring radioactivity carried out by the Operator around Fessenheim Nuclear Power Plant

Type of measurement	Average results 1990	When the cloud from Chernobyl was passing over (maximum values)
(Permanent) ambient radiation	0.01 to 0.04 $\mu\text{Gy.h}^{-1}$	0.15 $\mu\text{Gy.h}^{-1}$
aerosols in air on filter, measured 6 days after sampling	total β : 0.34 to 0.67 mBq.m^{-3}	total β :12 Bq.m^{-3} I131:3.5 Bq.m^{-3}
(Rhine) riverwater during effluent release	total β <1.1 Bq.l^{-1} H3<35 Bq.l^{-1}	I131:46 Bq.l^{-1} Cs137:7 Bq.l^{-1}
(Weekly) rainwater	total β <0.61 Bq.l^{-1}	I131:1030 Bq.l^{-1} Cs137:1388 Bq.l^{-1}
(Monthly) groundwater	total β <0.63 Bq.l^{-1} H3 < 34 Bq.l^{-1}	
(Monthly) land vegetation	total β (excluding K40) = 190 $\text{Bq.kg}^{-1}\text{sec}$	
(Monthly) milk	total β (excluding K40) <0.43 Bq.l^{-1}	total β :290 Bq.l^{-1} I131:140 Bq.l^{-1} Cs137:42 Bq.l^{-1}

Every month, the Plant distributes these results to Local Public Authorities, elected representatives and media. The results are also displayed on Minitel (national public information service). SCPRI carries out complementary tests concerning the whole of France, the results of which are also displayed on Minitel.

4. TEN-YEARLY RADIOECOLOGICAL ASSESSMENT

This study [5] was carried out after 12 years in operation at the time of the ten-yearly outage programme for both units. It consists of γ spectrometry on all samples and measurements of H3, Sr, Pu on some of them. For the earth ecosystem, at stations representative of the compass, samples of soil, milk, irrigation water, produce (corn, wine, wheat, lucerne, etc) are taken and analyzed (table 3)

Table 3 : Artificial γ radioactivity (in Bq.kg^{-1} (dry weight)) in some samples from the land around the Plant :

	Vine soil	Moss	Lucerne	Corn
Cs 134	1.6 \pm 0.5	81 \pm 4	---	---
Cs 137	14 \pm 2	413 \pm 13	0.1 \pm 0.1	0.19 \pm 0.1
Ag 110m	---	0.5 \pm 0.3	---	---
Co 60	---	0.3 \pm 0.2	---	---

The arboreal mosses, excellent radio-indicators, contain radioelements attributable to radioactive fallout from Chernobyl. The traces of Co 60 are probably related to Plant aerosols. A thorough analysis [6] of the concentration and deposit of Cs 137 in the soil, taking into account the effect of radioactive fallout from Chernobyl, has completely exonerated gaseous release from the Plant. Concerning the aquatic ecosystem (water, sediment, vegetation, fish) the results show that the Chernobyl accident has greatly influenced radioactivity levels (table 4).

Table 4: Examples of artificial γ radioactivity in the Rhine (in Bq.kg-1(d.w.) for sediment and vegetation, in Bq.kg-1(w.w.) for fish).

	Upstream			Downstream		
	Sediment	Vegetation	Fish	Sediment	Vegetation	Fish
Cs 134	18 ± 2	5.2 ± 1.9	0.4 ± 0.2	11 ± 3	2 ± 0.9	0.4 ± 0.1
Cs 137	97 ± 10	25.4 ± 2.8	2.2 ± 0.3	57 ± 3	7.5 ± 1.5	2.1 ± 0.2
Co 58	1 ± 0.5	8.5 ± 2.8	---	3 ± 1	69 ± 6	---
Co 60	4 ± 1	10 ± 3	---	3 ± 1	16 ± 2	---
Mn 54	1 ± 0.5	2.8 ± 1.4	---	---	3.3 ± 1.1	---

The presence of radiocobalt upstream from Fessenheim is attributable to effluent from a Nuclear Power Plant on the Upper Rhine. The isotopic ratio of Caesium corresponds to that of Chernobyl. Downstream, the concentration of Co 58+60 in aquatic vegetation can be attributed to liquid effluent from Fessenheim Nuclear Power Plant.

5. ANNUAL RADIOECOLOGICAL MONITORING

EDF has decided on a simplified annual monitoring programme for all Sites. It is currently being perfected technically for implementation in 1992. Thus, approximately thirty radio-indicators on land and in water (continental and marine) can be monitored with γ spectrometry and, if necessary, radiochemical analyses. There will therefore be a data bank permanently updated, according to time and space.

CONCLUSION

The impact of 12 years of operating Fessenheim Nuclear Power Plant is represented by a slight presence of artificial radioelements in the environment. These results underline the importance of radioecological testing before Plant start-up and during its operation, thus enabling any anomaly to be discovered at any time. In accordance with a national desire for openness, the public is informed of the results of these tests by the authorities, elected representatives and media [7]. The results can thus be compared to those of other existing networks of measurement. Moreover, the radioecological studies are the subject of published scientific papers [8]. The link between industry and research is thus correctly developed.

BIBLIOGRAPHY

- [1] CEA-CEN Saclay - Campagne de mesure d'équivalent de dose à Fessenheim - Oct Nov 1972
- [2] CEA-CEN Saclay - Campagne complémentaire d'analyses sur le site de Fessenheim - Feb 1975
- [3] INRA et Centre de Recherches Nucléaires de Strasbourg - Contribution à l'étude écologique de la région de Fessenheim - Dec 1978
- [4] Laboratoire vétérinaire de la ville de Colmar - Mesures de radioactivité des poissons
- [5] CEA-IPSN-SERE - Bilan radioécologique de la Centrale de Fessenheim - July - Sep 1989
- [6] CEA-IPSN-SERE - Roussel S. - Examen des mesures de Cs 134 et Cs 137 des sols dans la région de Fessenheim - June 1990
- [7] EDF-DPT - Environnement année 1990 - Rapport d'activité
- [8] FOULQUIER L et al - Exemples d'impact radioécologique de centrales nucléaires sur les cours d'eau français. Sous presse dans la revue d'hydroécologie appliquée

LES NOUVELLES GRANDEURS OPERATIONNELLES DE L'ICRU ET LEUR IMPACT SUR LES TECHNIQUES DE DOSIMETRIE EN RADIOPROTECTION.

G.PORTAL. CEA/Institut de Protection et de Sûreté Nucléaire:
DPHD/S.DOS./BP N.6,92265 FONTENAY AUX ROSES France.

ICRU NEW OPERATIONAL QUANTITIES AND THEIR IMPLICATION ON RADIATION PROTECTION INSTRUMENTATION

In defining the new operational quantities (NOQ) the ICRU sought concepts applicable with the use of existing instrumentation or which do not introduce too drastic modifications for the design of future instrumentation. A short presentation of the last ICRU recommendations on the definitions and conditions of use of these new quantities is given.

The implications of these quantities on the design of radiation protection instrumentation is analysed.

1. INTRODUCTION

L'équivalent de dose et l'équivalent de dose efficace ont été pendant longtemps les principales grandeurs utilisées en radioprotection mais les conditions dans lesquelles elles doivent être déterminées en pratique n'ont été abordées que récemment, par l'ICRU et l'ICRP, dans une série de publications où les "nouvelles grandeurs opérationnelles" (NGO) ont été définies et leur mise en oeuvre précisée (ICRU 39, ICRP 51, ICRU 43, ICRU XX).

Le comité de travail de l'ICRU qui a proposé ces NGO s'était fixé comme règle de rechercher des concepts qui soient mesurables, en pratique, sans bouleverser les méthodes et l'instrumentation existante.

Dans ce document on analyse l'impact des NGO sur les méthodes et les moyens mis en oeuvre en radioprotection.

2. LES NOUVELLES GRANDEURS OPERATIONNELLES.

Les définitions de "l'Equivalent de dose ambiant" " H^* " et de "l'Equivalent de dose directionnel" " H " n'ont pas évolué depuis leur origine bien que les critères d'utilisation aient été précisés différemment dans le dernier document (ICRU XX) à paraître. Les équivalents de dose individuels, profond H_p et superficiel H_s , sont remplacés dans la dernière publication par "l'équivalent de dose personnel" " $H_p(d)$ " où d représente la profondeur de référence: 0.07 mm, 3 mm, 10 mm.

Les points essentiels suivants sont précisés dans ce document.

a/ Les étalonnages doivent être effectués en terme de:

- H^* pour les dosimètres de champ destinés à la mesure des rayonnements pénétrants.
- H pour les dosimètres de champ destinés à la mesure des rayonnements faiblement pénétrants.
- $H_p(d)$ pour les dosimètres individuels.

Ces derniers doivent être placés sur un fantôme; pour des raisons pratiques, il est conseillé d'utiliser pour l'étalonnage en photons une plaque de polyméthylmétacrylate (lucite,

plexiglas, etc;) de 15cm * 30cm * 30cm. La grandeur utilisée pour l'étalonnage est $H_p(d)$ dans un fantôme de même composition que le tissu ICRU et de même dimension et forme que le fantôme utilisé pour l'étalonnage.

b/- Les dosimètres de champ de rayonnement pénétrant doivent présenter une réponse angulaire "isotrope"; leur indication ne doit donc pas varier avec l'angle d'incidence du rayonnement.

- Les dosimètres de champ de rayonnement peu pénétrant et les dosimètres individuels doivent présenter une réponse angulaire "isodirectionnelle"; ceci implique que leur indication I varie avec l'angle d'incidence en accord avec la grandeur considérée. On a alors: I / H' ou $I / H_p(d) = Cste$.

3. ADEQUATION DE L'INSTRUMENTATION EXISTANTE

Les caractéristiques essentielles mises en jeu par l'introduction des NGO concernent la réponse énergétique et la réponse angulaire.

3.1. Dosimètres de champ

3.1.1. Rayonnement pénétrant.

Un instrument destiné à mesurer l'équivalent de dose ambiant doit présenter une réponse angulaire isotrope et une réponse énergétique qui tient compte du rayonnement diffusé par le fantôme.

a/ Pour la dosimétrie des photons et des neutrons, l'instrumentation existante présente déjà une réponse isotrope (Tab.1)

b/ L'instrumentation destinée à la dosimétrie des photons, à l'exception de celle qui est conçue pour la mesure de l'exposition, présente une réponse énergétique très voisine de celle impliquée par la mesure de H^* ou peut être facilement adaptée par l'interposition de filtres permettant d'ajuster l'épaisseur des parois à la profondeur de référence. Il y a lieu de remarquer que certains instruments, comme les GM, sont mieux adaptés à la mesure de H^* qu'à celle de l'exposition (PORTAL 88).

c/ L'instrumentation utilisée jusqu'alors pour la dosimétrie des neutrons était adaptée à la mesure de l'équivalent de dose maximal dans un fantôme cylindrique (MADE); la profondeur de mesure variait donc avec l'énergie des neutrons. En fait l'introduction de H^* n'entraîne une différence significative que dans la gamme d'énergie de 100 eV à 1 KeV; les incertitudes qui en découlent pour les mesures effectuées "sur le terrain" sont minimes.

3.1.2. Rayonnement faiblement pénétrant.

La réponse énergétique de l'instrumentation destinée à mesurer H est similaire à celle de l'instrumentation existante dans la mesure où la profondeur de référence est identique; dans le cas contraire il suffit de petits ajustements pour l'adapter.

La réponse angulaire doit être isodirectionnelle et non isotrope comme c'est souvent le cas avec l'instrumentation destinée à la mesure de la dose absorbée. De ce fait les appareils dont l'élément détecteur présente une géométrie cylindrique ne sont pas adaptés à la mesure de H . Seuls ceux qui sont dotés d'un capteur plan sont utilisables sans modification (Chambre à extrapolation, diodes, etc.) (Table.1).

3.2. Dosimètres individuels

La plupart des dosimètres individuels sont déjà conçus pour déterminer l'équivalent de dose à une profondeur de 0.07, 3 ou 10mm. Leur réponse énergétique est alignée sur la dose absorbée dans le cas des photons et sur l'équivalent de dose maximal (MADE) pour les neutrons. Elle n'est donc pas fondamentalement différente de celle impliquée par l'utilisation des NGO. Si les profondeurs de référence ne sont pas respectées, il suffit le plus souvent d'effectuer des ajustements mineurs pour l'améliorer (Table 1).

Leur réponse angulaire doit être isodirectionnelle. Comme précédemment, ce n'est pas le cas pour ceux qui mettent en oeuvre un élément détecteur de géométrie cylindrique (Compteur proportionnel, Chambre à ionisation, Dosimètre à bulles); leur conception doit être révisée. Ceux qui sont dotés d'un détecteur plan peuvent présenter une réponse isodirectionnelle (Emulsions photographiques et nucléaires, Détecteurs thermoluminescents, Diodes, etc.). Cependant ceci n'est pas toujours exact pour les dosimètres à neutrons qui sont dotés d'un convertisseur (n,p) généralement mince; la profondeur de référence n'est pas respectée (Emulsion nucléaire NTA, Détecteur solide de traces, etc.); leur réponse n'est pas isodirectionnelle (Voir figure 1).

4. CONCLUSION

La plupart des appareils utilisés jusqu'alors peuvent être conservés pour la mesure des nouvelles grandeurs opérationnelles; il suffit le plus souvent d'effectuer un changement d'échelle pour tenir compte du changement d'unité. Le seul problème qui se pose concerne le défaut de réponse isodirectionnelle des dosimètres individuels et des dosimètres de champ pour les rayonnements faiblement pénétrants. Cependant ce problème n'est pas nouveau; c'est par souci de simplification que l'on concevait dans le passé des détecteurs isotropes mais ceci n'était nullement justifié.

En fait l'évolution des dosimètres à neutrons sera surtout imposée par l'application des recommandations de l'ICRP 60 qui exigent des modifications importantes de leur réponse énergétique (du fait des changements apportés aux facteurs de qualité) et de leur seuil de détection qui devrait être réduit d'un facteur 5 à 10 (PORTAL 1991).

4. REFERENCES.

HANKINS D., HOMMANN S., WESTERMARK J., **The LLNL CR39 Personal Neutron Dosimeter**, Radiat. Prot. Dosim., **23**, 195-198 (88).

JAHR R, HOLLNAGEL R, SIEBERT B.R.L., **Calculations of specified Depth dose equiv.**, Radiat. Prot. Dosim., **10**, 75-87 (85).

PORTAL G, 1988, **Implication of ICRU 39 for radioprotection instrumentation**, Radiat. Prot. Dosim., **23**, 99-103 (88).

PORTAL G, 1991, **Implication of new ICRP-ICRU recommendations on neutron dosimetry**. To be published in Rad. Prot. Dosim..

SCHWARTZ, R.B. and HUNT, J.B., **Measurement of the energy response of superheated drop neutron detectors**, Rad. Pro. Dosim., **34**, 377/380 (1990).

	PHOTONS				ELECTRONS				NEUTRONS			
	He		R α		Re		R α		Re		R α	
	A	I	A	I	A	I	A	I	A	I	A	I
<i>Ioniz. chamb.</i>	0	0	0	-	0	0	0	-	0	0	0	-
<i>Prop. Count.</i>	0	0	0	-	0	0	0	-	0	0	0	-
<i>GM</i>	+	+	0	-	0	-	0	-	0	0	0	-
<i>Scintill.</i>	0	0	0	-	0	0	0	-	0	0	0	-
<i>Semi Conduct</i>	+	+	0	+	0	0	+	+	0	0	0	0
<i>Photo. film.</i>		+		+		0		+		0		0
<i>Nucl. Emuls.</i>										0		0
<i>TLD</i>			0	+		0		+		0		0
<i>RPL</i>			+	-		0		0		0		0
<i>Bubble</i>									0	0	0	-
<i>Track etch</i>									0		0	+

Adaptability of Instrumentation to N.O.D. / Adequation de l'Instrumentation aux N.G.O.

- Less convenient 0 Equivalent + Better
 - Moins bonne 0 Egale + Meilleure

A - Area Monitors = Dosimètres de champs I - Individual Dosimeters = Dosimètre individuels

Table 1. Adequation de l'instrumentation aux NGO.

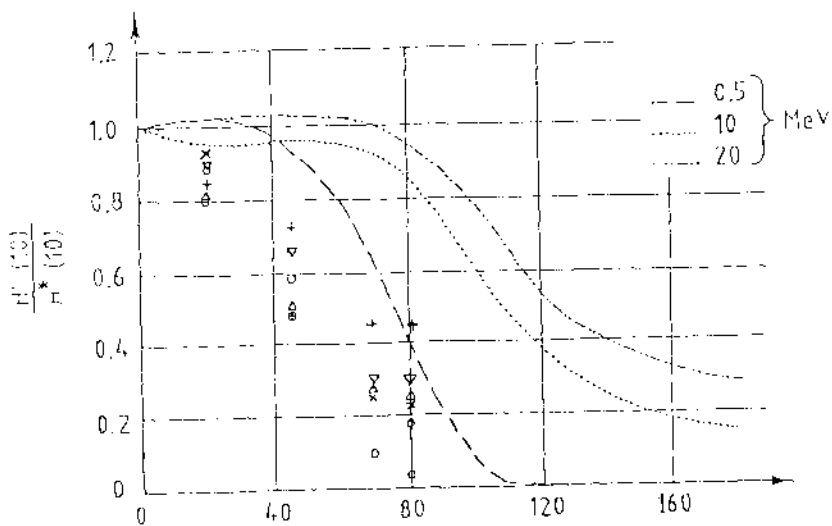

Figure 1. Reponse angulaire des dosimetres individuels
 Courbes theoriques (JAHR, 85); Points experiment^x (HANKINS 88)
 0.13 à 0.4 MeV 0.45 à 1.1 MeV 1.3 à 1.6 MeV
 3 à 5 MeV 14 à 16 MeV

MONITORING OF RADIOACTIVE LIQUID EFFLUENTS GENERATED AT INSTITUTO DE PESQUISAS ENERGÉTICAS E NUCLEARES AND ENVIRONMENTAL BEHAVIOUR OF RADIONUCLIDES IN THE ECOSYSTEM OF PINHEIROS RIVER

V.M.F.Jacomino; M.F.Maduar; G.Hiromoto; A.M.P.L. Gordon;
L.Venturini and A.J.G.dos Santos.

Instituto de Pesquisas Energéticas e Nucleares
Comissão Nacional de Energia Nuclear
Cx. Postal 11049 - 05499 São Paulo-SP, Brazil

ABSTRACT

In order to allow an assessment of the environmental impact due to the operation of the IPEN's facilities and an evaluation of the adequacy of the effluent emission control system, a continuous effluent monitoring program has been carried out. During the year of 1990, the total activity discharged was 7.7×10^8 Bq, diluted on 1.4×10^3 m³ of water. The effective dose equivalent in the critical group was 6.8×10^{-5} mSv, mainly due to the exposure to Co-60, Cs-137 and Cs 134. It should be emphasized, however, that none of these radionuclides has been detected in the environmental samples.

INTRODUCTION

All the radioactive liquid effluents generated at Instituto de Pesquisas Energéticas e Nucleares (IPEN) are discharged, after an adequate treatment, into the aquatic system of Pinheiros river. In order to control such releases into the environment, an effluent monitoring program has been established on a routine basis. In this paper, results of the source-term are presented concerning the period from January/88 to December/90 together with the estimate of the effective dose equivalent to the general public. Data relative to the levels of radioactivity in environmental samples collected in the ecosystem of Pinheiros river during the year of 1989, are also presented.

LIQUID EFFLUENT RELEASE SOURCE-TERM FOR THE PERIOD FROM JANUARY/88 TO DECEMBER/90

The liquid effluents from most of the IPEN's facilities or laboratories are stored and controlled in their respective retention tanks. Each batch of the effluents generated is sampled and measured by gamma spectrometry using a HPGe detector. If the samples contain uranium and/or thorium, the activity of these radionuclides is measured by neutron activation or spectrophotometric analysis. The total activity together with the total volume of water released during the period from January/88 to December/90 is summarized in Table I.

After proper operational controls at the source, a decision is made about discharge of each batch into the sewage system of the Institute, according to the national regulatory rules⁽¹⁾.

EVALUATION OF THE RADIATION DOSE TO THE INDIVIDUALS OF THE PUBLIC

All the low-level liquid effluents authorized for release are discharged into the Pinheiros river. These releases are made through the sewage system of the Institute. The effluents enter into the river at two separated points, two kilometers apart, through two sewage lines; one of them outflows direct into Pinheiros river and the other one outflows into Jaguaré stream before reaching Pinheiros river.

At the moment there is complete lack of aquatic life in this river due to the high quantity of sewage discharged continuously and due to severe industrial pollution. There is no use of the water neither for human consumption nor for irrigation purposes. Only some factories localized at the river borderlines pump the water for industrial machine refrigeration.

In this case, the main exposure pathway to be considered is the gamma external irradiation of the individuals of the public who work at the river bank near the discharge point. The dose received by this critical group was evaluated according to the IAEA model ⁽²⁾ and using adequate dose factors ⁽³⁾. It was assumed a continuous release of liquid effluents into the river. The final results of the annual effective dose equivalent are presented in Table 1. The main radionuclides which contributed to exposure during the period from January/88 to December/90 were Co-60, Cs-137 and Cs-134.

MEASUREMENT OF ACTIVITIES IN WATER AND SEDIMENTS OF PINHEIROS RIVER

Samples of water and sediments were collected at five points of Pinheiros river and analyzed by gamma spectrometry; uranium contents were determined by fluorimetry. The points of monitoring are described below:

- Point 1: Control point, localized about 3 km upstream from the first effluent discharge point.
- Point 2: First effluent discharge point, localized at the mixing point where Jaguaré stream joins the river flow.
- Point 3: Second effluent discharge point about 2 km downstream from Point 2.
- Point 4: Morumbi bridge, about 4 km downstream from Point 3.
- Point 5: Discharge point of Pinheiros river into Billings reservoir, about 10 km downstream from Point 4.

Only natural radionuclides were detected in these environmental samples, as follows: Ra-228, Ra-226, Be-7 and K-40, with activities corresponding to the background levels.

These measurements are made only periodically since sufficient data has been accumulated during the last years, so that the control of radiation doses to members of the public might be reduced solely to the monitoring at the points of discharge of the Institute.

TABLE I - Results of the total activity in the liquid effluents released during the period from January/88 to December/90 and total effective dose equivalent (H_E) in the critical group.

year	total activity released (Bq/y)	total volume (m^3/y)	H_E (mSv/y)
1988	2.0×10^9	2.4×10^3	2.7×10^{-5}
1989	4.0×10^9	1.2×10^3	5.6×10^{-5}
1990	7.7×10^8	1.4×10^3	6.8×10^{-5}

CONCLUSIONS

Results of dose calculations in the critical group showed that radiological consequences to the environment due to radionuclides releases into the Pinheiros river through IPEN's sewage system are negligible at the moment. The levels of radioactivity found in water and sediments river samples are in agreement with the expected values, considering that the effluents released are diluted in a high volume of water by the time they reach the receptor river.

REFERENCES

1. Comissão Nacional de Energia Nuclear. Gerência de Rejeitos Radioativos em Instalações Radioativas. Rio de Janeiro, 1985. (CNEN-NE-6.05.85).
2. International Atomic Energy Agency. Generic Models and Parameter for Assessing the Environmental Transfer of Radionuclides from Routine Releases. Exposures of Critical Groups. STI/PUB/611 Vienna: IAEA (1982).
3. Till, J.E. & Meyer, H.E. Radiological Assessment: a text book on environmental dose analysis. Washigton, D.C., Nuclear Regulatory Comission, 1983.

DEVELOPMENT OF GAMMA PROBE FOR RADIATION SURVEYS
OF THE BOTTOMS OF SURFACE WATERS

D.R. Lee, S.J. Welch, M.J. St. Aubin and R. Dal Bianco

Environmental Research Branch
Chalk River Laboratories
AECL Research
Chalk River, Ontario, KOJ 1J0, Canada
(613) 584-3311

ABSTRACT

We have developed a practical method for mapping variations in gamma activity and electrical conductivity of submerged sediments. Prototype probes are being constructed and tested. The first prototype was essentially a background survey meter (Jones, 1979) packaged in a 53-cm-long by 5.4-cm-diameter waterproof vehicle. This tubular vehicle was towed by boat in contact with the bottom sediments of lakes and rivers. Originally, this vehicle was designed (and is still frequently used) for locating groundwater and contaminant entry areas in surface waters. By logging geographic position and sediment variables, it has been possible to produce contour maps in areas of interest. Thus it is possible to optimize environmental analysis and avoid the "hit or miss" approach of traditional bottom-sediment surveys.

INTRODUCTION

Contaminants present in surface-water discharges as a result of industrial effluents can accumulate in bottom sediments. Because of the overlying water, it has been difficult to determine the areal distribution of contaminants in these sediments. Consequently, environmental questions often cannot be addressed without great cost. Mobile methods for rapid detection and mapping of sediment contamination would greatly enhance the value of laboratory analyses required for monitoring. If areas of potential contamination were surveyed and the results shown on a map, it would be possible to verify the effectiveness of monitoring, reduce its cost or focus on corrective action.

Most instruments, presently used for underwater surveys, are designed to operate some distance above the bottom, not in contact with it, to avoid snagging, abrasion or damage. Although many contaminants are preferentially associated with sediments, they cannot be readily detected without direct sediment contact. Several devices have been designed to be lowered to the bottom to make point measurements, but they do not provide information between the points of measurement. A continuous line of data along the bottom can be decisive because contaminants are rarely distributed uniformly. Some large devices have been designed for towing behind oceanographic vessels. These devices are unsuited for surveys on the bottoms of lakes, estuaries or rivers, particularly near shore-based industrial areas.

Many radionuclides that may be present in industrial discharges become associated with bottom sediments. Shielding by water prevents detection unless the detector is within a few centimeters of the radioactivity. Consequently, most radiometric surveys of bottom sediments are done by sediment coring and subsequent laboratory analyses. However, coring is a point sampling approach. Without a measure of spatial heterogeneity, coring can not provide satisfactory coverage without enormous effort. Therefore, the detailed, quantitative information from sediment cores can rarely be used fully.

The project outlined here was designed to provide continuous line data that could be used to generate contour maps of gamma activity distributions. Such a map could be used to select coring locations and to reduce the numbers of cores required. Quantitative information from these cores can be used to calibrate the mapped distributions. A map of sediment radioactivity could also help form conceptual models for aquatic transport, dispersion and deposition. Information on the lateral distributions of gamma activity of bottom sediments could also help to verify the results of effluent monitoring programs, improve the information quality of bottom samples that are taken to answer allegations regarding release of contaminants, and to establish representative monitoring points. Where there are valid concerns that sediments may be contaminating invertebrates or fish, a contour map of gamma activity can help target areas for definitive study.

BOTTOM-CONTACT SEDIMENT SURVEY PROBE

The probe serves as an underwater gamma radiation survey vehicle that can be towed along the bottom of a body of water with minimal snagging. Another requirement was that the vehicle remain oriented so that detectors in the probe would "look" toward the bottom, or upward toward the overlying water.

The initial prototype was a 53-cm-long x 5.4-cm-diameter tube, closed at both ends and containing a Geiger-Muller tube. Lead was added inside of the 5.4-cm-diameter tube to keep the probe on the bottom during normal towing speeds of 1 meter per second. Mass within the tube was distributed to maintain the orientation of the probe. Orientation also ensured that contact with the bottom could be ascertained while the probe was underway, by monitoring electrical conductance with electrodes located along the lower side of the probe. During towing, the probe did not roll or twist along its longitudinal axis by more than 10 degrees, so that the sensors, which had been fixed within the vehicle, were oriented to "look" up, down, or sideways (Jones, 1979; Lee and Beattie, 1991).

A stretched version of the probe was built to allow adjustment of the probe mass by the addition or removal of lead weights, while at the same time preserving the self-orienting feature of the probe. Where sediments were very soft, it was advantageous to increase or decrease the overall mass for selected runs. Also, in the stretched version, the lead shielding over the upper and lateral sides of the detector was removed so that radiation could be detected from all around.

Because of their robustness, the two detectors used to date have been Geiger-Muller tubes. The two Geiger-Muller tubes used have outer dimensions of 26.7-cm long x 2.25-cm diameter and 99.3-cm long x 5.075-cm diameter. In laboratory tests, the larger tube has been shown to be 16 times more sensitive than the smaller tube. Currently, the larger tube is being incorporated into a second probe and a third device, which will have a NaI detector, is being designed.

FIELD-PORTABLE DATA ACQUISITION

A geographic positioning system has been interfaced to a computer for logging the position of the probe while it is underway. The positioning system is portable, semi-automatic and laser-based. Tests have shown that records of sediment variables and geographic location (to plus or minus one meter) can be logged under field conditions.

A portable computer has been modified and software has been written to convert analog signals to digital data, to store these data and display concurrent, real-time records of gamma activity and sediment conductivity. Having a real-time graphical display, the operators are able to identify key sampling locations, and to form a mental image of the underlying spatial variations of the sediment. Therefore, the density of coverage and the sampling for ground truth was adjusted at early stages of the current investigation of the Chalk River waterfront on the Ottawa River.

With geographic positioning, the system has allowed us to collect data for creating coloured contour maps of the distributions of sediment radioactivity and conductivity. Results of work along the Chalk River waterfront have shown good agreement between laboratory analyses of river sediment and contour maps made with this data acquisition system. Good agreement has also been seen between point data and probe results in a study of a small pond near one of the waste management areas at Chalk River.

CONCLUSION

A new approach to underwater monitoring near industrial sites has been introduced for surveying areas of interest in aquatic environments. The approach has the potential to reduce the costs of monitoring and remediation by identifying specific areas for detailed study. Sediment monitoring or cleanup can be targeted on locations where maximum benefit can be obtained.

REFERENCES

- Jones, A.R., 1979. Two survey meters for measuring low gamma-ray dose rates. AECL Research, AECL-6407.
- Lee, D.R. and Beattie, W.J., 1991. Gamma survey probe for use on ocean, lake, estuary and river sediments. United States Patent Number 5,050,525. Other patents pending.

BILAN DE LA SURVEILLANCE DE LA RADIOACTIVITE DANS
L'ENVIRONNEMENT DES SITES DU COMMISSARIAT A L' ENERGIE
ATOMIQUE

D. ROBEAU, M. MONTJOIE, A.M. SAUVE, J. LAPORTE, A. RAHAPLEN,
L. ALPHONSE, C. HUC, C. BENSIMON*, G CISSOKO*.

C.E.A./INSTITUT DE PROTECTION ET DE SURETE NUCLEAIRE
CENTRE D'ETUDES DE FONTENAY AUX ROSES
F92265 FONTENAY AUX ROSES CEDEX

* COMPAGNIE INTERNATIONALE DE SERVICES INFORMATIQUES

RADIOACTIVE SURVEY OF THE ENVIRONMENT OF THE NUCLEAR SITES
OF FRENCH NUCLEAR BOARD : AN OVERVIEW

C.E.A. has set up a network of radioactive survey around its nuclear sites. This network involves terrestrial, atmospheric and marine results of radioactive measurements. This survey is structured in four levels. The level 0 homogenizes stations of measurements, level 1 centralizes real-time measurements of gross α and β measurements of atmospheric radioactivity, level 2 and 3 centralizes postponed α - β spectrometric measurements of radioactivity on water, deposition, grass, vegetables. People can have a squint at these results of measurements using popular MINITEL telephonic network.

1. INTRODUCTION.

La surveillance du niveau de radioactivité de l'environnement des sites du Commissariat à l'Energie Atomique a accompagné, depuis leur création, leurs activités. Cette surveillance est particulièrement rigoureuse autour des sites civils de Fontenay-aux-roses, de Saclay, de Grenoble, de Cadarache; des sites militaires de Valduc, Bruyères-le-Châtel; des sites industriels de La Hague, Marcoule, Pierrelatte. Elle est dirigée par la direction de chaque établissement.

Par décision de l'Administrateur Général du C.E.A. un réseau surveillance de l'environnement a été créé à la suite des besoins d'information précis et rapides qui ont été mis en évidence, notamment, lors de l'accident survenu à la centrale de Tchernobyl.

Par la suite, une directive du Premier Ministre, puis du Ministre de l'Industrie ont insisté sur la nécessité pour les exploitants de l'industrie nucléaire d'informer le public des niveaux de radioactivité enregistrés autour des installations nucléaires. Les résultats de mesures de la radioactivité du réseau de surveillance créé par le C.E.A. ont donc été mis à la disposition du public par divers moyens d'information.

2. LA STRUCTURE DU RESEAU DE SURVEILLANCE.

2.1. Les éléments du réseau.

Ce réseau de surveillance appelé SYTAR (Système de Transmission et d'Alarme Radiologique) relie les sites de BRUYERES-LE-CHATEL, CADARACHE, FONTENAY-AUX-ROSES, GRENOBLE, LA HAGUE, MARCOULE, PIERRELATTE, SACLAY, VALDUC, MONTHLERY. Il intègre également un réseau de surveillance atmosphérique comprenant six stations de mesures de forte sensibilité et un réseau de surveillance marine comprenant quinze stations de prélèvement sur les côtes de la Manche et de la Méditerranée. Ces deux réseaux, ainsi que le réseau SYTAR sont exploités par l'IPSN (Institut de Protection et de Sûreté Nucléaire).

2.2 Les niveaux du réseau

Le réseau est structuré en quatre niveaux fonctionnant parallèlement, avec des fréquences différentes.

2.2.1. Le niveau 0.

Ce niveau 0 a pour objectif de donner toutes informations sur la nature (type d'appareillage, seuil de mesure, radionucléide de référence, ...) et l'état de fonctionnement des matériels de mesure. Un second objectif de ce niveau est l'harmonisation des appareillages et des seuils de mesures. Les éléments de ce niveau sont modifiés lors d'un changement, d'un arrêt ou d'une remise en fonctionnement d'un appareil.

2.2.2. Le niveau 1.

Ce niveau 1 a pour objectif d'homogénéiser et de centraliser les résultats de mesure des radioactivités atmosphériques α et β (radioactivités naturelle, artificielle et totale), les résultats de mesure de l'irradiation γ des gaz. Les mesures de ce niveau sont faites en temps réel, par des balises BFSAB (Balise à Filtre Séquentiel Alpha et Beta). La balise fournit une mesure de l'irradiation γ exprimée en $\mu\text{Gy h}^{-1}$ et une mesure de la radioactivité des gaz en Bq m^{-3} . Les traitements sont effectués à partir de la fréquence des impulsions fournies par les capteurs; pour obtenir l'activité des gaz, le niveau d'irradiation naturelle est soustrait après lissage des résultats. Cette balise permet également des mesures directes et retardées à 24 heures de l'activité α et β des aérosols.

2.2.3. Le niveau 2.

Ce niveau 2 a pour objectif d'homogénéiser et de centraliser les résultats de mesure de la radioactivité par spectrométrie α , β et γ , des prélèvements d'aérosols, des dépôts et des eaux. Ces mesures sont effectuées

hebdomadairement en situation normale.

2.2.4. Le niveau 3.

Ce niveau 3 a pour objectif d'homogénéiser et de centraliser les résultats de mesure de la radioactivité par spectrométrie α , β et γ , des prélèvements d'herbe et de végétaux (fruits, légumes, feuilles). Ces mesures sont effectuées mensuellement en situation normale.

3. LES MOYENS D'INFORMATION DU RESEAU.

3.1. Les aspects médiatiques du réseau.

Ce réseau est un système d'information des autorités du CEA mais aussi du public. Pour le public les résultats de mesures de la radioactivité sont pour chacun des sites et pour chacun des niveaux moyennés sur un mois. Les valeurs moyennes des 12 mois précédents sont également indiquées, à titre de référence. Ces résultats sont alors édités trimestriellement et consultables par le public par l'intermédiaire du réseau télématique MINITEL.

3.2. Tableau de bord de la radioactivité d'un site.

Un exemple de tableau de bord des mesures de la radioactivité fourni à la fois aux autorités et au public est illustré par les graphiques ci-après. Ce tableau de bord est celui relatif au niveau de la radioactivité de l'environnement du site de Grenoble pour l'année 1990 (département de l'Isère dans le Sud-Est de la France). Ce tableau de bord regroupe les résultats mensuels de l'irradiation externe, des activités α et β totales des aérosols de l'atmosphère, des activités β totales des eaux de surface et de l'herbe, ainsi que l'activité en ^{137}Cs de l'herbe et du lait.

BIBLIOGRAPHIE

[1] D. ROBEAU, 1990 Réseau de transmission et d'alerte radiologique du groupe CEA. 16^{ème} congrès ATSR sur l'intervention nucléaire sur le territoire national -Dijon 3-4-5 octobre 1990.

[2] D. ROBEAU, C. LEBRUN, A.M. SAUVE, J. LAPORTE, C. BENSIMON, L. ALPHONSE, 1990. Mise en oeuvre opérationnelle du réseau de transmission des mesures de radioactivité de l'environnement du groupe CEA. 2nd International Workshop on real time computing of the environmental consequences of an accidental release to the atmosphere from a nuclear installation. Luxembourg 16-19 Mai 1990.

IRRADIATION EXTERNE (Gy/a)

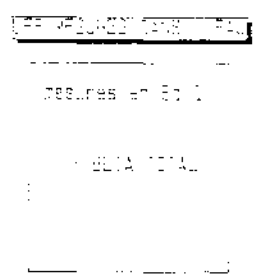
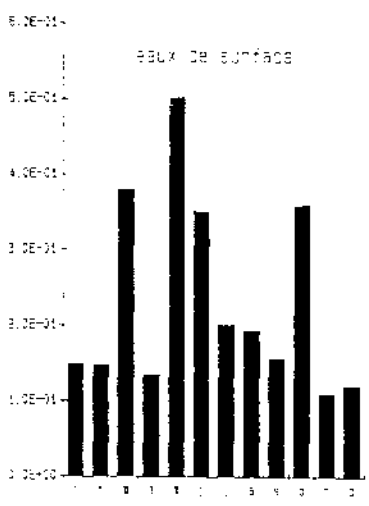
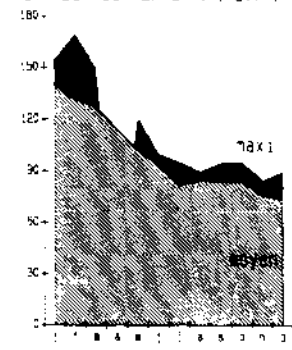

ALPHA ET BETA TOTALX (Bq/m3)

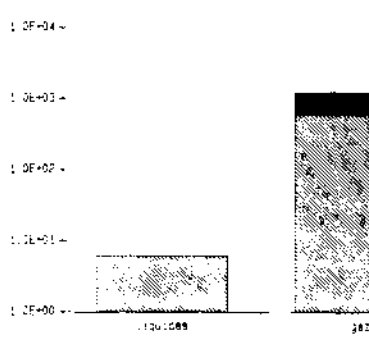

LE LAIT (Bq/l)

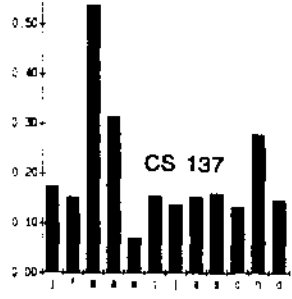

L'HERBE (Bq/kg frais)

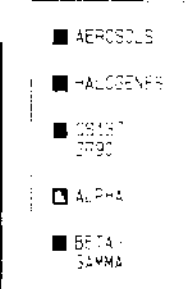
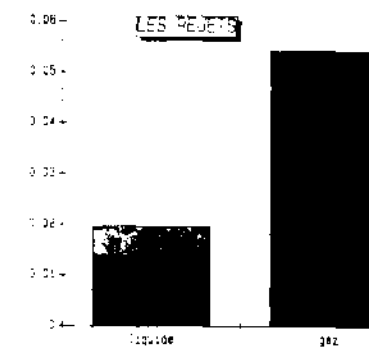
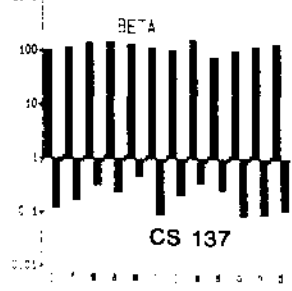

CONTINUOUS MONITORING SYSTEM OF ^3H , ^{14}C , AND $^{129/131}\text{I}$
IN OFF-GAS FROM NUCLEAR FUEL REPROCESSING PLANT

S. Kojima, M. Shibuya, T. Higashijima, M. Fujiso, T. Kato
and K. Suzuki

JGC Corporation
14-1, Bessho 1-chome, Minami-ku, Yokohama, 232 Japan

S. Takimoto and A. Takita

Japan Nuclear Fuel Service Company, Ltd.
2-2, 2-chome, Uchisaiwai-cho, Chiyoda-ku, Tokyo, 100 Japan

ABSTRACT

Off-gas released from nuclear fuel reprocessing plants contains ^3H , ^{14}C , and $^{129/131}\text{I}$, and ^{85}Kr . In order to design a system which continuously monitors the concentrations of the former four nuclides with the coexistence of ^{85}Kr , the performance of elementary technologies was tested such as catalytic oxidation, gas separation by permeable membranes, adsorption of iodine, and radiation measurement. A combination of these technologies could be applied for detection of ^3H , ^{14}C , and $^{129/131}\text{I}$ with ^{85}Kr down to 1.0×10^{-3} , 3.7×10^{-4} , and 3.7×10^{-8} Bq/cm³, respectively.

1. Introduction

From the standpoint of radiation control for the public, it is desirable to monitor gaseous radioactivity in off-gas from nuclear facilities. In the off-gas from a nuclear fuel reprocessing plant, however, ^{85}Kr coexists at 10^2 - 10^3 times the concentrations of ^3H , ^{14}C , and $^{129/131}\text{I}$, and, in addition, these radionuclides have several chemical forms. This leads to the difficulty of continuous measurement of radioactivity. In this research, assuming the following basic flow for continuous monitoring, fundamental studies of elementary technologies were carried out.

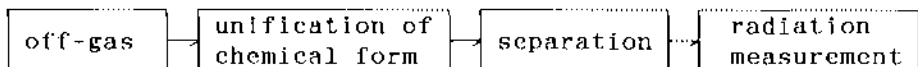

2. Targeted discrimination factor (DF^{*1}) of separation for continuous monitoring

The targeted DFs of separation for continuous monitoring of ^3H , ^{14}C , and $^{129/131}\text{I}$ were calculated, based on a performance of radiation detectors and the estimated annual discharge of gaseous radioactivity released from a nuclear fuel

*1: DF means a ratio of gas concentration of feed to permeate.

reprocessing plant⁽¹⁾. In this study, the radioactivity detectors were selected as shown in the Table 1. More than 10^5 and 10^7 were obtained for the targeted DFs of ^{85}Kr to ^3H , ^{14}C , or $^{129}/^{131}\text{I}$ and that of for ^{14}C to ^3H , respectively.

Table 1. Detectors for ^3H , ^{14}C $^{129}/^{131}\text{I}$ monitoring.

nuclide	detectable limit Bq/cm ³	detector
^3H	6×10^{-4}	proportional counter with pulse-shape discriminator
^{14}C	4×10^{-4}	plastic scintillator
^{129}I	$3 \times 10^{-8*}$	N-type Ge semiconductor detector
^{131}I	$1 \times 10^{-8*}$	N-type Ge semiconductor detector

*:The values can be attained by adsorption of iodine in 14m³ off-gas

3. Unification of chemical forms

CH_4 is assumed to be the most difficult compound to oxidize among the chemical components containing radionuclides of ^3H and/or ^{14}C in off-gas. More than 95% of CH_4 could be converted into CO_2 by oxidation at 400 °C and at a space velocity of 10^4h^{-1} , using a Pd-alumina catalyst. In the case of iodine, it was revealed that the adsorption of iodine on Pd catalyst and piping makes it difficult to measure the correct concentration of iodine. Thus, it was determined that iodine should be separated from Kr by TEDA-impregnated charcoal which can capture both I_2 and CH_3I .

4. Gas separation by permeable membranes

An HTO monitoring system using vapor separation membranes was developed and the DF value for ^{85}Kr was reported to be 10^4 ⁽²⁾. Further, the ^{85}Kr separation from $^{14}\text{CO}_2$ or Ar by silicone membranes was also studied^(2,3). These methods have low DFs and require an appropriate system for applying to ^{85}Kr removal and HTO separation for off-gas from reprocessing plants.

4.1 Gas separation for ^3H monitoring

The permeability of H_2O , Kr, and CO_2 was investigated to determine a membrane suited to the selective permeation of H_2O . Commercially available hollow-fiber type modules such as perfluorocarboxylic acid membrane (FLEMION), perfluorosulfonic acid membrane (NAFION), and polyimide membrane (UPIREX) were used for the purpose. The gas permeation rates at 40 °C are shown in the Table 2. NAFION and FLEMION have a higher ratio of permeation rate for H_2O to for Kr. Of the two membranes, FLEMION indicated a more rapid response to H_2O permeation. FLEMION was selected as the HTO permeation membrane in view of

its high permeability and rapid response. The permeation rate of FLEMION depends on humidity and falls to less than 1/10 in dry air. However, the rate decrease could be prevented by controlling humidity to be 20 °C as dew point in the purge gas.

A separation system whose $DF(Kr/H_2O) = 5.0 \times 10^6$, $DF(CO_2/H_2O) = 3.0 \times 10^4$, and $C/C_0(H_2O)^{*2} = 0.77$ to 1 could be established by using two-stage of FLEMION hollow fiber modules and humidifying the permeate side. Combining this system with the proportional counter enables a continuous monitoring system to be established for 3H , which ensures a detectable 3H concentration limit of 1.0×10^{-3} Bq/cm³ when ^{85}Kr and ^{14}C exist with 1.0×10^4 and 60 Bq/cm³, respectively.

Table 2. Permeation rates of gases to be separated at 40 °C.

Membrane	Permeation rates at 40 °C (cm ³ /cm ² ·cmHg·s)		
	H ₂ O	CO ₂	Kr
NAFION	4×10^{-3}	2×10^{-6}	8×10^{-8}
FLEMION	1×10^{-2}	8×10^{-7}	1×10^{-7}
UPIREX	2×10^{-3}	5×10^{-5}	1×10^{-6}
SILICONE	5×10^{-4}	5×10^{-5}	3×10^{-5}

4.2 Gas separation for ^{14}C monitoring

UPIREX was selected for the separation of CO₂ from Kr because the DF of Kr is as high as 50, which is the highest among other membranes. To attain a DF for Kr higher than 10⁶, a multi-stage separation system and the high value of C/C₀ for CO₂ are required. This requirement could be satisfied by increasing the pressure difference between the feed side and the permeate side. Pressurization of feed gas is advantageous for making the system compact.

A separation system whose $DF(Kr) = 10^5$ and $C/C_0 = 1$ was established by adopting the four-stage separation of UPIREX in which the supply side is pressurized to 4 atm. By combining this system with the plastic scintillation detector, it is possible to design a continuous monitoring system whose ^{14}C detectable concentration limit can be 3.7×10^{-3} Bq/cm³ in the presence of ^{85}Kr of 3.7×10^7 Bq/cm³.

5. Design of monitoring system

A monitoring system based on the test results is shown in the Figure. In this system, $^{129}I/^{131}I$ in the off-gas is at first captured by the TEDA-impregnated charcoal cartridge. At the same time, $^{129}I/^{131}I$ is measured by an N-type Ge semiconductor detector, which enables monitoring at a level of 10^{-6} Hq/cm³. The charcoal cartridge is automatically replaced

*2: C/C₀ means a ratio of gas concentration of feed to permeate.

at intervals of four hours, and then additional measurements for other four hours are performed to detect down to a level of 3.7×10^{-8} Bq/cm³ by holding the charcoal cartridge between two N-type Ge semiconductor detectors. After iodine is captured, ¹⁴C and ³H are oxidized in order to unify their chemical forms into CO₂ and H₂O respectively by Pd-alumina catalyst. Then, ¹⁴CO₂ and HTO are separated from interfering nuclides by the above-mentioned membrane separation systems and measured by the plastic scintillation detector and the proportional counter, respectively, which are shown in table 1.

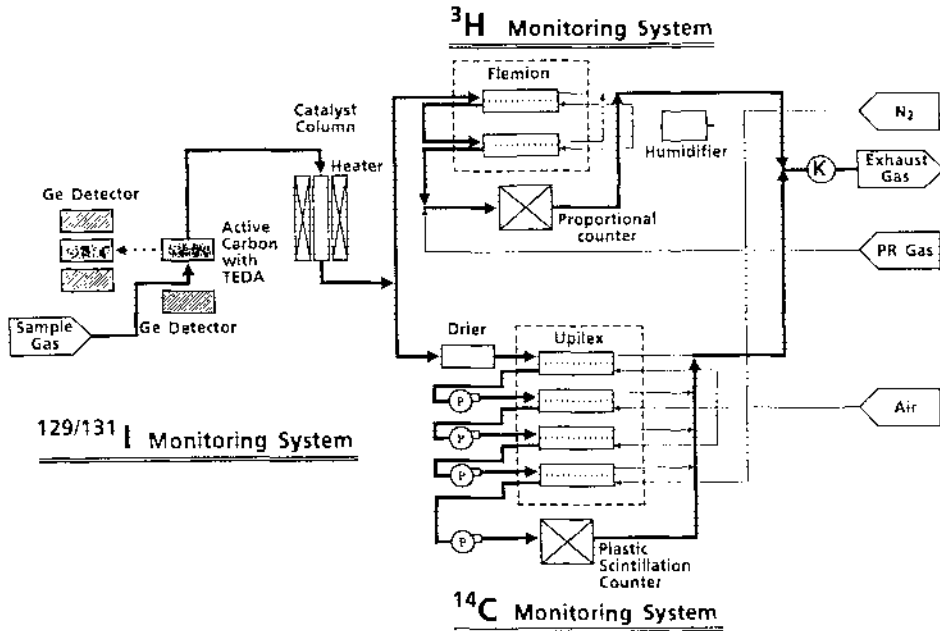

Fig. Process Flow of ^{129/131}I, ¹⁴C and ³H Monitoring System

6. Conclusion

A system was established for continuously monitoring the ³H, ¹⁴C, and ^{129/131}I concentrations in off-gas released from reprocessing plants in the presence of ⁸⁵Kr.

REFERENCES

- (1) Takimoto, S., Hokenbutsuri, 25,399-409(1990), in Japanese.
- (2) Fernandez, S. J., et al, WINCO-1015(1984).
- (3) Ralney, R. H., et al, ORNL-4255(1971).

ACKNOWLEDGEMENTS

This research work was sponsored by ten electric power companies in Japan and Japan Nuclear Fuel Service Co., Ltd.

CLASSIFICATION OF MONITORING SITES AROUND TSURUGA NUCLEAR
POWER STATION BASED ON VARIOUS VARIATIONAL PATTERNS
OF AVERAGE MONTHLY EXPOSURE RATES

Y. Ogawa*, Y. Kimura*, Y. Honda*,
I. Urabe** and T. Tsujimoto***

* Department of Nuclear Engineering, Kinki University,
Osaka, Japan

** Fukuyama University, Hiroshima, Japan

*** Research Reactor Institute, Kyoto University, Osaka,
Japan

ABSTRACT

In order to elucidate the fluctuations of the exposure rate, classification of monitoring sites based on various variational patterns of monthly exposure rate was attempted. To obtain various variational patterns, seasonal adjustment method and period analysis method were used. By comparing various variational patterns and correlation coefficients, classification of monitoring sites could be carried out. The classification of monitoring sites is an useful tool to get some information for estimating the reasons and the intensity of variation on exposure rates.

INTRODUCTION

The exposure rates due to environmental gamma-rays show roughly constant levels at respective monitoring sites. However, if examined in detail, the exposure rate varies periodically or occasionally from several to ten-several percent. It is important to make clear the reasons of the variation from the view points of monitoring of nuclear facilities and research of environmental radiation and radioactivity. In order to elucidate the fluctuations of the exposure rate due to environmental gamma-rays near nuclear power station, classification of monitoring sites was attempted. This paper briefly describes monitoring site classification method based on various variational patterns of monthly exposure rate. As an application of this method, classification of monitoring sites around TSURUGA Nuclear Power Station is also described.

MONITORING SITE CLASSIFICATION METHOD

To obtain various variational patterns of monthly exposure rate, time series analysis methods, that is, seasonal adjustment method and period analysis method, were used. Seasonal adjustment method calculates trend-circular exposure rate, seasonal factor and irregular factor by the moving average method. Trend-circular exposure rate represents the moving average of original data and the deviation of original data from trend-circular exposure rate represents

seasonal and irregular factors. The periodic component of this deviation is seasonal factor and the rest is irregular factor. Period analysis method, on the other hand, calculates periodgram by the finite fourier transformation. Periodgram represents the order of periods involved in original data. From the calculational results obtained, the interpretation of variational patterns is discussed.

Using time series analysis methods mentioned above, monitoring site classification based on various variational patterns of monthly exposure rate could be carried out as follows.

Step 1. Calculate correlation coefficients among monthly exposure rates at monitoring site,

Step 2. Calculate monthly trend-circular exposure rate, seasonal factor and irregular factor of monthly exposure rate at each monitoring site by seasonal adjustment method,

Step 3. Calculate correlation coefficients among monthly trend-circular exposure rates at monitoring site,

Step 4. Calculate periodgram of monthly exposure rates at each monitoring site by period analysis method,

Step 5. Calculate periodgram of trend-circular exposure rate at each monitoring site,

Step 6. Compare the various variational patterns and the correlation coefficients,

Step 7. Classify monitoring sites.

Flow chart of monitoring site classification method is shown in Fig.1.

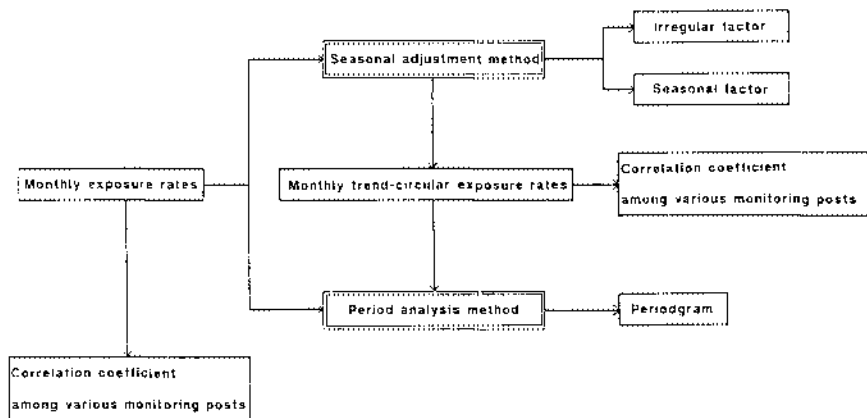

Fig.1 Monitoring site classification method based on various variational patterns of monthly exposure rates

Using this monitoring site classification method, the classification of monitoring sites around TSURUGA Nuclear Power Station was carried out. The area around TURUGA Nuclear Power Station is the area of higher exposure rates due to the terrestrial natural gamma-rays than the other

area in FUKUI Prefecture. Monthly exposure rates measured and evaluated at nine monitoring sites from April 1984 to March 1990 were used.

CLASSIFICATION RESULTS AND DISCUSSION

Several typical characteristics obtained from the calculational results and the classification of monitoring sites are listed below.

Considering seasonal factor obtained from seasonal adjustment method, there are three types of monitoring sites.

Type 1 : Monitoring site where low monthly exposure rate in winter has been measured because of shielding terrestrial gamma-rays by the snow.

Type 2 : Monitoring site where low monthly exposure rate in winter and rainy season has been measured because of shielding terrestrial gamma-rays by the snow and by the increase of water content in soil.

Type 3 : Monitoring site where no significant seasonal variation in monthly exposure rate has been measured.

Considering periodogram obtained from period analysis method, there are three types of monitoring sites.

Type 4 : Monitoring site where seasonal variation in monthly exposure rate has been measured because of the influence of the four seasons.

Type 5 : Monitoring site where trend variation in monthly exposure rate has been measured because of the gradual change of the topography.

Type 6 : Monitoring site where zigzag variation in monthly exposure rate has been measured.

Considering correlation coefficients, there are two types of monitoring sites.

Type 7 : Monitoring site where similar variation in monthly exposure rate to that at the other monitoring site has been measured because of the similar influence of environmental conditions.

Type 8 : Monitoring site where similar variation in trend-circular exposure rate to that at the other monitoring site has been measured because of the similar influence of environmental conditions without the effect of the four seasons.

From the classification results obtained, the reason of spatial and time dependent variation on exposure rate could be estimated by investigating in detail at the other monitoring site which has the similar classified characteristics, if low or high exposure rate were temporarily measured at some monitoring sites. Accordingly, the classification of monitoring sites is an useful tool to get some information for estimating the reasons and the intensity of varia-

tion on exposure rate.

CONCLUSION

In order to elucidate the fluctuations of the exposure rate due to environmental gamma-rays near nuclear power stations, classification of monitoring sites based on various variational patterns of monthly exposure rate was attempted. To obtain various variational patterns, time series analysis methods, that is, seasonal adjustment method and period analysis method, were used. By comparing various variational patterns and correlation coefficients among monthly exposure rates at monitoring site, classification of monitoring sites could be carried out.

Using this monitoring site classification method, the classification of monitoring sites around TSURUGA Nuclear Power Station, where is the area of higher exposure rate due to the terrestrial natural gamma-rays than the other are in FUKUI Prefecture, was carried out. As a results, it is found that there are eight types of monitoring sites which have typical similar characteristics around TSURUGA Nuclear Power Station.

From the classification of monitoring sites, the reason of spatial and time dependent variation on exposure rates could be estimated by investigating in detail at the other monitoring site which has the classified similar characteristics. Accordingly, the classification of monitoring sites is an useful tool to get some information for estimating the reasons and the intensity of variation on exposure rates.

REFERENCES

1. Bureau of the Census, 1967, The X-11 Variant of the Census Method II Seasonal Adjustment Program, U.S. Department of Commerce, Technical Paper No.15.
2. Ogawa,Y., Kimura,Y., Honda,Y., Katsurayama,K., Urabe, I. and Tsujimoto,T., 1989, Time Series Analysis on Ambient Radiation - On Census Method II X-11 - (in Japanese), J. Fac. Sci. Technol. Kinki Univ., 25, pp. 187-191.
3. Ogawa,Y., Kimura,Y., Honda,Y., Urabe,I. and Tsujimoto, T., 1990, Time Series Analysis on Ambient Radiation (II) - On Period Analysis Method - (in Japanese), J. Fac. Sci. Technol. Kinki Univ., 26, pp. 161-164.
4. Ogawa,Y., Kimura,Y., Honda,Y., Urabe,I. and Tsujimoto, T., 1991, Monitoring Site Classification Method Based on Various Variational Patterns of Monthly Exposure Rate (in Japanese), J. Fac. Sci. Technol. Kinki Univ., 27, pp. 160-171.

RADIOLOGICAL DOSE ASSESSMENTS IN THE NORTHERN MARSHALL ISLANDS (1989-1991)^a

L.C. Sun, C.B. Meinhold, A.R. Moorthy,
J.H. Clinton, and E. Kaplan

Radiological Science Division,
Department of Nuclear Energy,
Brookhaven National Laboratory, Upton, NY 11973

Introduction

The Republic of the Marshall Islands (RMI) is located in the central Pacific Ocean about 3,500 km southwest of Hawaii and 4,500 km east of Manila, Philippines. It consists of 34 atolls and 2 coral islands, having a total land area of about 180 km², distributed over more than 2.5×10^6 km² of ocean. Between 1946 and 1958 the United States conducted nuclear tests there: 43 at Enewetak and 23 at Bikini. Thirty-three years after the cessation of nuclear testing in the RMI, the impact of these operations on the health and radiological safety of the people living in or planning to return to their contaminated homelands is still an important concern⁽¹⁾⁽²⁾.

The present Brookhaven National Laboratory (BNL) Marshall Islands Radiological Safety Program (MIRSP) began in 1987 with funding from the U.S. Department of Energy (DOE). The objectives of the MIRSP are to determine the radionuclides present in the bodies of those people potentially exposed to residual radionuclide from weapon tests and fallout, and to assess their present and lifetime dose from external and internal sources. Field bioassay missions involving whole-body counting (WBC) and urine sample collection have, therefore, been important components of the program. WBC is used to measure γ -emitters, such as ⁴⁰K, ⁶⁰Co and ¹³⁷Cs, present in individuals. Urine samples are used to measure α and β -emitting nuclides, such as ²³⁹Pu and ⁹⁰Sr, that are undetectable by WBC routine methods.

Whole-Body Counting Program

Whole-body counting measurements are conducted on a voluntary basis. Two complete counting systems are operated simultaneously and independently during daily WBC operations. The counting time is 15 minutes per measurement. About 50 to 60 measurements could be completed in a working day. A total of 916 persons were counted in 1989. This group included 216 the people of (dri-) Enewetak, 258 dri-Rongelap, and 414 dri-Utirik. Also included were 28 visitors, workers, and DOE personnel, listed as "Others". A total of 1,051 persons participated in the WBC in 1991; 311 dri-Enewetak, 272 dri-Utirik, 427 dri-Rongelap, and 41 Others. Since 1985, when

^a This work was supported by the US DOE under contract #DE-AC02-76CH00016

dri-Rongelap self-exiled to Mejatto Island, all Rongelap measurements were obtained at Mejatto.

^{137}Cs is the only fallout nuclide detected in the WBC measurements. The highest value from any of the three missions was 14 kBq. Except at Enewetak, all measurements showed a decrease from 1989 to 1991. Dose calculations from the ^{137}Cs body counts were based on an ICRP-56 tabulation of conversion factors⁽³⁾ used to compute the committed effective dose equivalents (CEDE) following acute exposures to cesium at different ages. The conversion factor of 1.4×10^{-8} Sv/Bq for 15 year old individuals was used for conservative reasons. The ICRP-30 retention function⁽⁴⁾ indicates that 90% of the CEDE is received within the first year of exposure, and that a 2.8 ratio exists if a constant level of ^{137}Cs is maintained as opposed to its being eliminated from the body in one year. Therefore, the annual effective dose equivalents (AEDE) were calculated by multiplying the CEDE by factors of 0.9 and 2.8. Table 1 shows the AEDE that an individual would receive due to uniform chronic exposure throughout an entire year.

Population	1989	1991
Enewetak	11 ± 3	22 ± 4
Rongelap	3 ± 2	2 ± 2
Utirik	39 ± 2	35 ± 3

Plutonium Measurements and Urinalysis Program

In 1983, a Photon Electron Rejection Alpha Liquid Scintillation (PERALS) system was used for ^{239}Pu urinalysis for the Marshallese. Unexpectedly high apparent ^{239}Pu activities (130 μBq) in samples collected from a location that should not have been affected by the Bravo fallout were obtained. It was subsequently shown that most of the measured ^{239}Pu was actually ^{210}Po which could not be differentiated by the PERALS system. These findings prompted development of a fission track analytical (FTA) technique⁽⁵⁾ that would be capable of detecting very low-levels of ^{239}Pu without interference from ^{210}Po . By 1987, FTA could be used to detect values as low as 4 μBq per sample of ^{239}Pu . With further improvements, a sensitivity of about 2 μBq was achieved in 1989.

As of December 1988, a total of 195 Rongelap and 300 Utirik urine samples were analyzed at BNL. These 495 samples were collected from volunteers during field missions conducted between 1981 to 1984. The frequency distribution for the ^{239}Pu values from the Marshallese urine were log-normal with the 50 percentile (geometric mean) at about 9 μBq per sample for Rongelap and 4 μBq for Utirik. The 95% of the results were below 37 μBq for both populations. The highest value measured was 174 μBq .

Among the 195 Rongelap FTA results, 22 cases were found with inconsistent results from individuals who participated in the urine program more than once during the 1981-1984 missions. Three potential causes for these disparities were investigated: (1) was it possible that small amounts of contaminated soil were getting into the urine samples and thereby resulting in false estimates of plutonium excreted by the individual? (2) were the 24-h urine volumes used in the calculations appropriate and did each sample contain the entire 24 hour urine output as required for a proper systemic burden estimate? (3) were the other metabolic parameters used in this calculation appropriate for the Marshall Islanders?

In September 1988, urine samples were collected from individuals residing on Mejatto, Utirik, and Majuro. FTA values from the 146 urine measurements (67 Rongelap and 79 Utirik) and urine-blanks (26 synthetic and 76 composite human urine from a BNL employee) are shown in Table 2. For dri-Utirik, the values of mean (μ) and standard deviation (σ) were higher than those of Rongelap because of one sample containing 742 tracks (about 50 μBq of ^{239}Pu). Since samples collected from this same person in 1981 and 1989 were both less than the minimum detection limit (MDL), we concluded that the 1988 reading was due to contamination.

	n	μ	σ	median
Dri-Rongelap	67	59	34	56
Dri-Utirik	79	64	82	54
BNL-Employee	76	54	29	49
Synthetic-Urine	44	37	15	43

The MDL ($\mu + 3\sigma$) derived from the synthetic urine data was 82 tracks. All samples greater than 82 tracks are considered to have statistically significant levels of ^{239}Pu activity. Otherwise, less than MDL was reported.

In 1989, a new urine collection protocol was developed which approximates the precision and accuracy obtainable in a hospital. Collection bottles were no longer distributed to participants for use at their homes. Instead, all samples were taken on the mission vessel over a controlled 24-h period, and were acidified (16N HNO_3 , 10% by volume) within 24 hours of the collection period. A group of 32 individuals who previously had ^{239}Pu readings greater than 11 μBq were resampled in 1989. Only two of these samples were above the MDL of 2 μBq (i.e., 2.8 and 2.4 μBq). These data lead to the conclusion that soil contamination was the cause of earlier abnormally high readings, and provided confidence in the new urine collection protocol. The 2.8 μBq is equivalent to a CEDE of 0.4 mSv.

Interlaboratory Comparison of ^{137}Cs and ^{239}Pu Data

For ^{137}Cs , BNL whole-body counts yielded an average of 3.7 kBq in 1984; Lawrence Livermore National Laboratory (LLNL) estimated 5.9 kBq could be expected using their environmental sample measurements and availability of imported foods. For ^{239}Pu , BNL estimated an CEDE of 0.40 mSv from the interpretation of Rongelap urine data; and LLNL estimated 0.46 mSv from dietary assumptions, intake pathway analysis, and Pu activities measured in foods, dust and soil⁽⁶⁾.

Reference:

1. Adams, W.H., Heotis, P.M., and Scott, W.A., 1989, "Medical Status of Marshallese Accidentally Exposed to 1954 Bravo Fallout Radiation: January 1985 through December 1987." BNL-52192, Brookhaven National Laboratory, Upton, NY.
2. Kohn, H., 1989, "Rongelap Reassessment Project," Report to the President and Congress of the United States, Corrected Edition, 1203 Shattuck Ave, Berkeley, Calif., March 1, 1989.
3. International Commission on Radiological Protection, 1990, "Age Dependent Doses to Member of the Public from Intake of Radio-nuclides," Publication 56, Part 1, Pergamon Press, p.57.
4. International Commission on Radiological Protection, 1978, "Limits for Intakes of Radionuclides by Worker," Publication 30, Part 1, Pergamon Press.
5. Moorthy A.R., Schopfer C.J., and Bannerjee S., 1988, "Plutonium from Atmospheric Weapons Testing: Fission Track Analysis of Urine Samples, Analytical Chemistry, 60, 857A.
6. Robison, W.L., Sun, L.C., Meinhold, C.B., 1990, "The Radiological Dose from Pu at Rongelap Island," Paper prepared for DOE Marshall Islands Program.

**DETERMINATION OF DISPERSION CONDITIONS
BY USE OF WIND TUNNEL EXPERIMENTS
UNDER THE PRESENCE OF DISTURBING INFLUENCES IN THE COURSE OF
CALCULATIONS OF THE LOAD OF SURROUNDING AREAS.**

P. Guglhör, K.H. Lehmann, A.M. Rall

Technical Inspection Agency of Bavaria (TÜV Bayern)
Radiation Protection and
Waste Engineering Department
Atmospheric Dispersion and Radioecology
Munich, Germany

ABSTRACT

Dispersion conditions are often inhomogenous and instationary because of the local presence of disturbing influences. Experimental investigations in a wind tunnel allow the analysis of these disturbed dispersion conditions. Thus a realistic calculation of the atmospheric diffusion of emitted radioactive substances is possible.

INTRODUCTION

The method of calculation of the atmospheric dispersion of emitted radioactive materials is according to German regulations based on the so called Gaussian plume model. The parameters used for this model are valid for homogeneous stationary dispersion conditions especially for emissions from elevated point sources respectively. Basic assumptions of this model are not met if the dispersion of the exhaust is disturbed by emissions of cooling towers of a power plant or by building structures or marked orographic situations. A Gaussian plume model cannot reasonably be used without modified model parameters under such conditions. Often dramatic differences are seen between the undisturbed dispersion conditions over plane areas and the aerodynamic conditions under actual site specific orographic and geometric situations. Important aerodynamic effects are changes of the mean wind profile, the structure of turbulence (zones of displacement, recirculations and channelling effects). These effects occur inhomogeneously in space and instationary with time.

EVALUATION OF DISPERSION CONDITIONS

The transport and the dilution of emitted radioactive substances in the atmosphere occurs by turbulent diffusion. Under the assumption of a quasi-continuous emission of these substances during normal operation of the power plant according to generally accepted models plumes are formed. Its spatial and temporal behaviour is heavily influenced by the dispersion situations at the site. These dispersion situations depend on

the meteorological conditions at the site, the emission heights and the influence of the surrounding area, the nearby buildings and cooling towers. The calculations of the atmospheric dispersion are based besides on the technical emission data mainly on the temporal average of dispersion conditions as well as on the meteorological conditions.

In accordance with the German regulations it is necessary to determine the most important parameters which influence the dispersion of the plume by experimental investigations at a properly scaled model in a wind tunnel.

INHOMOGENEOUS AND INSTATIONARY DISPERSION CONDITIONS

Often significant differences are seen between the flow patterns of undisturbed dispersion conditions over a plane area and those of an actual site with a specific orographic and/or geometric situation.

If a homogeneous atmospheric flow hits an obstacle complex aerodynamical effects occur like:

- changes of the mean wind profile,
- changes of the flow pattern,
 - . bent flow lines,
 - . abrupt changes of velocity,
- change of turbulence structure e.g.,
 - . zones of displacement,
 - . zones of recirculation,
- aerodynamical effects of buildings or cooling towers,
- channeling effects,
- thermally caused circulation effects.

Wind tunnel experiments were conducted by Technical Inspection Agency of Bavaria for sites with different conditions like

- complex industrial areas with complicated building structures and sources with low emission heights,
- power plants in special orographic situations (sites in a valley, steep slopes in the nearby vicinity, channelling effects by a curved valley),
- influence of cooling towers of different design,
- influence of different surface structures in the vicinity.

WIND TUNNEL EXPERIMENTS FOR DETERMINATION OF DISPERSION CONDITION AT A SITE

It is the purpose of the wind tunnel experiments to simulate and quantitatively evaluate the dispersion conditions controlled by site specific aerodynamical effects using a model true to nature and properly scaled in a way that modified model parameters also of non-straight trajectories as well as

spatial dispersion factors result for the calculation of radiation exposure.

Very important is the concept of the experiments concerning the validity of the results of the experiments in the nature /1/. The wind tunnel experiments must be planned and conducted in a way that based on the valid relations of similarity statements can be made for the total relevant range of wind velocities.

- A: In a first step smoke gas visualisation experiments are carried out. They are recorded by a video tape recorder. Laser sheet images are a good tool for collecting informations of the mean relative concentrations and their standard deviation using digital image processing.
- B: For obtaining quantitative results tracer gas experiments are conducted.
- C: The measurement of the tracer gas close to ground reveals directly the spatial dispersion factors (χ -value in s/m^3).
- D: From A: to C: a trajectory is chosen for each drift sector and wind velocity.
- E: Vertical concentration profiles are measured at selected points on each trajectory.
- F: Horizontal concentration profiles are measured perpendicular to each trajectory at the height of the maximum of the respective vertical concentration profile.
- G: From E: and F: the model parameters H_{eff} , Σ_y and Σ_z are calculated for each pair of profiles along the trajectories using a curve fitting methode.

CONCLUSION

The wind tunnel experiments allow the visualisation of influences of different parameters and the results of its tracer gas measurements enable the evaluation of the dispersion conditions of emitted radioactive substances quantitatively. They also allow to introduce suitable corrections for Gaussian type calculations in the course of licensing and surveillance procedures of nuclear sites as well as for their online remote monitoring systems.

LITERATURE

- /1/ E.J.Plate: Wind tunnel modelling of wind effects in Engineering Meteorology, Chapter 13, Elsevier Scientific Publishing Company, Amsterdam, 1982

AUTOMATIC SYSTEM FOR CONTINUOUS MONITORING OF GAMMA ACTIVITIES IN
ATMOSPHERIC PARTICULATE

M. MONTALTO, R. GIACOMELLI, M. NOCENTE, S. BORTOLUZZI,
P. SPEZZANO

ENEA, AREA AMBIENTE, DIPARTIMENTO ANALISI E MONITORAGGIO
MASAL CRE SALUGGIA - ITALY

SUMMARY

This paper describes the design criteria, which were used for the realization of an automatic system for the real time monitoring of the artificial radioactivity in the air.

Special attention was paid to minimize particulate losses along device ducts.

Particulate losses showed to be lower than 10%. The minimum detectable activities and the particulate-collection showed, in every respect, to be equivalent to the traditional system.

DESCRIPTION OF THE AIR MONITORING SYSTEM

The automatic monitoring system allow perform gamma spectrometry at the same time of the filtering operation. Therefore, if the verification of the acquired counts is performed immediately, the air radioactivity values can be obtained almost instantaneously.

The air monitoring system includes:

- air sampler;
- spectra acquisition system;
- computer and various peripheral units.

The air sampler is formed by a filter holder and a suction unit.

The (patented) filter holder is directly mounted on the gamma radiation detector, and was designed so as to optimize both the flow rates of filtered water and the detection geometry of the radiations emitted by the radionuclides eventually present.

The air suction unit includes a centrifugal electric pump with graphite blades, a volumetric counter, and the regulation and protection devices for such components.

The suction unit is interfaced with a computer, by which it is possible to perform the setting and the remote control of every sampling parameter.

The system used for the acquisition of the gamma radiation spectra is formed by a high-purity germanium detector, located in a lead well, and connected to the multichannel.

The fully automatic operation of the monitoring system is managed by a computer, which is interfaced with the analyzing system, the flow meter, the alarm unit, and, finally, the eventual modem for data transmission to the national monitoring center.

Concerning the recognition of the alarm conditions, two different types of warning systems were arranged to distinguish between the malfunction of the devices and the detected air contamination.

DESCRIPTION OF FILTER HOLDER AND SUCTION DUCT

The filter holder (fig. 1) is formed by a cylindrical receptacle with a round opening at the bottom, so that it can be inserted on the detector.

A seal ring prevents air from passing between the detector and the filter holder.

The detector, by penetrating within the filter holder, forms a wall of the toroidal distribution manifold.

The toroidal manifold surrounds the cylindrical surface of the detector, and is connected with the filtering portion by a continuous ring slot.

The distance between detector and filter surface is approx. 1 mm.

The filter support is formed by a metal net, able to withstand 1-atm pressure without creating resistances to air flow.

The collection manifold is formed by a cylindrical-geometry chamber, located downstream of the filter and designed so as to convey the flow of filtered air towards the outlet duct.

The filter holder is kept in the correct position by the pressure generated by the depression of the suction pump.

The filter, with related support, can be reached from the upper side of the filter holder directly.

Every component of the filter holder is realized by electroconductive materials, in order to reduce the deposit of air particulate on the walls of the device itself due to the accumulation of electrostatic charges.

The operating principle of the filter holder is the following (with reference to figure 1):

- the air, coming from the sampling point located out of the laboratory through a properly sized duct, enters the toroidal distribution manifold A;
- due to the vacuum created by the suction pump in the collection manifold B, the air crosses the filter;
- the radioactivity, present in the particulate which is collected on the filter, is continuously measured by the high-purity germanium detector;
- from the collection manifold, the air passes the outlet duct and is sent out by the suction pump again.

Substantially, the device allows to perform the filtration operation on the flat filter directly facing the detection surface.

In addition, the use of the toroidal manifold allows to minimize the distances between filter and detector, and the loss of pressure, necessary to maintain the air flow.

Therefore, such a manifold allows to make the detection efficiency and the quantity of filtered air as high as possible.

The suction duct was designed by the use of some technical solutions so as to minimize the losses of air particulate [1].

The conduit was realized as short as possible. In detail, to reduce the settling, which is not depending upon the whole path of the aerosol in the conduit, but only upon the length of the projection on the horizontal plane of the conduit itself, we try to minimize the horizontal development [2].

Furthermore, the fluid mechanics in the conduit was chosen so as to reduce to a minimum the losses due to settling, diffusion, and impact for the particles having granulometry range of 0.2 to 2 μm [3].

EXPERIMENTAL MEASUREMENTS

To estimate the losses of particulate along the suction duct experimentally, some measurements of gross-alpha, gross-beta, and gamma spectrometry were carried out on the particulate, which collected on pairs of filters (type of filter: SCHLEICHER & SCHUELL-498/1) [4]; the measurements were obtained by contemporary filtering of the air both by

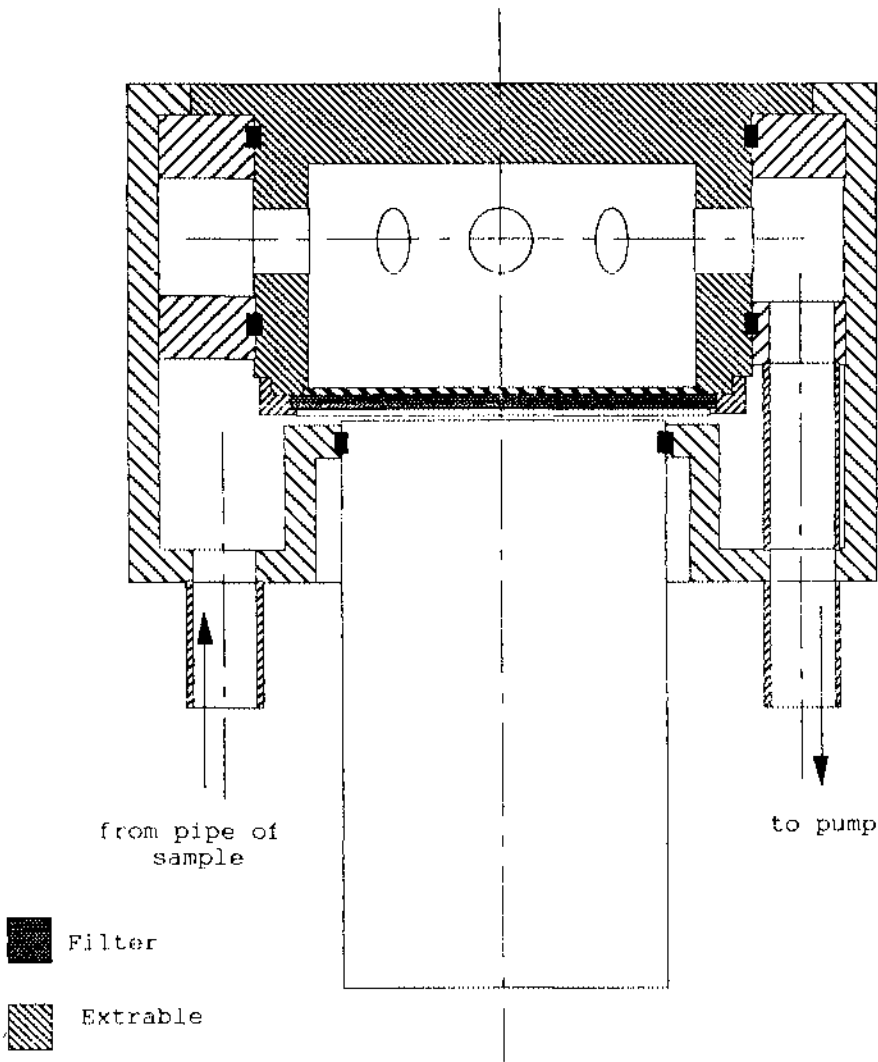

Figure 1 - Conventional representation of the filter holder

traditional system (without conduit upstream of the filter) and by automatic system.

At first, the measurements of gamma spectrometry were carried out; they allowed to estimate the content of Pb-212 for each filter. The losses showed to be lower than 6%.

Then, the measurements of gross-alpha and gross-beta radioactive emission were carried out.

The losses showed to be lower than 4%, if estimated as gross alpha, and lower than 6% as gross beta.

The analysis of the percentage differences obtained for the three types of measurements showed that, in the worst hypothesis, the loss of particulate can be estimated to be lower than 10%.

Furthermore, the minimum detectable activities and the detection efficiency were estimated; they showed, in every respect, to be equivalent to the traditional system.

CONCLUSIONS

The designed automatic monitoring system allows to carry out the monitoring of air radioactivity complying with the same operating parameters, which are used in the traditional manual procedure. In addition, it allows to reduce, even to few minutes, the time intervals between different measurements and, therefore, a continuous alarm system is available.

BIBLIOGRAPHY

- [1] J.W. THOMAS
Particle loss in sampling conduits - Proceeding of a Symposium
"Assessment of Airborn Radioactivity"
IAEA - Vienna 1967
- [2] T. TOMMASINI, G. GALUPPI
Sedimentazione gravitazionale di aerosol in condotte
ENEA-RT/PAS/85/21
- [3] R. GRAGNANI, I. MICHETTI, G. TARRONI, L. TESTA
Distribuzione dei principali radionuclidi nelle frazioni
granulometriche del particolato atmosferico della Casaccia (Roma)
a seguito dell'incidente di Chernobyl.
ENEA-RT/PAS/87/10
- [4] A. CIGNA - F. GIORCELLI
Normalizzazione delle misure beta totale dei prodotti di fissione
liberati dalle esplosioni nucleari.
ENEA-RT/TA(67)1/1967

RADON EXPOSURES IN THE UK

TO BE READ AT
INRA 8 MAY 1992

M C O'Riordan

National Radiological Protection Board,
Chilton, Didcot, Oxon OX11 0RQ, UK

ABSTRACT

Public and occupational health protection against radon is provided in the UK. Protection is advised where geological conditions cause high concentrations in domestic and commercial buildings. These circumstances are described and the resulting exposures reviewed. An account is given of the limitation scheme for radon in the home and the regulatory scheme for radon at work, the manner in which they are implemented, and the degree to which they are successful.

INTRODUCTION

Radon is the dominant source of human exposure to ionising radiation in every country of the world. It is dominant in most circumstances - at home and at work, for individual persons and for whole populations. The worst characteristic of radon, apart from its carcinogenicity, is its ubiquity: one of its few redeeming properties is lack of smell. We might also say in its favour that it is unlikely to reach such high concentrations as to cause acute clinical effects, although the doses to lung tissue in perfectly ordinary circumstances can indeed be considerable.

BACKGROUND

Virtually all of the 21 million dwellings in the UK are made of masonry and do not have basements. About one half are detached or semi-detached houses, about one third are terraced or row houses, and the remainder are flats or apartment buildings with multiple occupancy. Half of the housing stock has been renewed since the second World War. Commercial buildings vary from small converted houses to tall office blocks and large warehouses.

It is also necessary to describe the geological setting. There is a clear division between the igneous and metamorphic areas of the north and west and the sedimentary areas of the south and east that is most of England. Intrusive rocks often imply high radon levels, metamorphic and sedimentary rocks range from high to low, and extrusive rocks usually mean low levels.

CONTROLS

As in other countries, we in the UK have different approaches to the control of radon exposure in homes and places of work; our modus operandi is shown in Table 1. For householders, the commitment to measure and take action against radon is completely voluntary. Employers, on the contrary, are obliged to comply with statutory controls on occupational exposure in all places of work - schools, offices, factories and so on. Government employs encouragement in the first circumstance and enforcement in the second.

The Action Level for existing dwellings is 200 Bq m⁻³ of radon in air averaged throughout the year. New dwellings are to be designed so that levels are as low as reasonably practicable and not, of course, above the Action Level. The dose limit for workers is still 50 mSv a year, but employers are required by occupational legislation to prevent doses continually approaching it, and we have adopted a constraint of

15 mSv a year, on the average, in anticipation of the new ICRP recommendations. When the annual effective dose equivalent from radon is less than 5 mSv (which corresponds to an average 400 Bq m³ when temporal occupancy is considered) the enforcement agency does not require action by the employer.

DWELLINGS

By early 1992, around 110,000 dwellings in the UK had been surveyed for radon. As can be seen from Table 2, these measurements are mostly made at the request of householders. Virtually all are at public expense, the major source of funds being central Government. At an early stage in the radon programme, a positive decision was made to provide free measurements for householders who might have cause for concern about radon.

An initial survey by NRPB had two purposes, one to determine the distribution of indoor radon concentrations in a systematic manner and the other to discover the most radon-prone regions of the UK guided by limited radiological and geological information. The exercise was successful in that subsequent surveys have not confounded the initial findings.

Once the overall picture was clear, it was possible to adopt an intervention policy with known - and acceptable - implications. The key element was the delineation of so-called Affected Areas, where the probability of finding a dwelling above the chosen Action Level was one per cent. Within such areas, two significant steps would be taken: first, a campaign would be mounted to persuade householders to apply for free measurements; second, the building authorities would delimit localities within which new dwellings would require preventive measures. The latter requirement was not to apply to non-residential buildings.

So far, two administrative counties in the southwest of the country have been formally designated. Over three-quarters of the demand for measurements have arisen there, mostly as a result of the direct mailing of a radon leaflet to all householders. Nevertheless, the response was only one in eight, so more persuasive tactics will need to be tried. Government has indicated that similar plans will be carried through in other affected areas when these are defined.

Table 3 has a summary of the most significant results. In the first Affected Area, the average indoor concentration of radon is about five times the population-weighted value for the UK as a whole. In round terms, about 100,000 dwellings in the UK, or 0.5% of the housing stock, are estimated to be above the Action Level. So far, some 12,000 of these have been discovered, mostly in the first Affected Area. The radon-prone parts of the country are rural and much less densely populated than average: an appreciable fraction of the land area may eventually be designated.

WORKPLACES

There are, of course, far fewer workplaces than dwellings: Table 4 has the important statistics. Surveys of radon in places of work, initially funded by the Health and Safety Executive, now arise mainly from direct requests by employers. Not surprisingly, much of the demand comes from those regions of the country where raised radon levels occur in dwellings.

We estimate, again in round terms, that there may be about 50,000 places of work in the likely Affected Areas throughout the UK of which

one tenth may have radon levels above 400 Bq m^{-3} ; perhaps as many as 75,000 workers may therefore receive annual doses greater than 5 mSv. These estimates are based on surveys in 3000 premises, some 10% being found subject to the regulations. The maximum dose discovered to date is 45 mSv in a year, and only a few per cent of workers receive more than 15 mSv in a year. Radon levels in house-like places of work are similar to houses: levels in large industrial buildings are generally much lower.

INTERVENTION

Employers have a considerable incentive to reduce radon levels because by doing so they can avoid the necessity of mounting radiological surveillance in their premises and of complying with other regulatory requirements. About half of the workplaces initially found subject to the regulations, 150 or so, have subsequently had satisfactory remedial measures, mostly by sub-floor suction. Very few new commercial buildings have had preventive measures built in, however, because developers are not required to do so by law.

Householders, on the other hand, have some disincentive: if they decide to take remedial action, it is likely that they will have to pay since Government grants are restricted to those who do not have the means. This may explain why only 250 or so dwellings above the Action Level have been remedied so far. Various techniques such as floor sealing and positive pressure have been tried, but the most effective method is sub-floor suction especially for appreciable reductions. Since anti-radon measures become mandatory for new dwellings in certain localities, some 4000 have been built in line with developing technical guidance issued by Government which has proved to be quite effective.

DISCUSSION

This brief paper scarcely does justice to the radon programme in the UK which also embraces mining, geology, dosimetry, epidemiology, and metrology. Attention has rather been focussed on the determination and limitation of indoor exposure: some degree of success can be claimed for the few years in which the programme has been running. We have a coherent and judicious system of controls. We know what the general exposure levels are at home and at work and where raised values are most likely to be found. Our Government provides free measurements on a generous scale to householders in radon-prone areas so as to push the programme forward.

As a result, we have discovered about one tenth of the dwellings and workplaces throughout the UK that we believe to be adversely affected by radon. National policy is directed towards the goal of identifying most radon-affected homes by the end of the decade: to eliminate excessive exposures, it will therefore be necessary to redouble our efforts in the coming years. Many more householders and employers must be persuaded to make radon measurements, and having made them, to take whatever action is required to minimise the risk from radon. We are sanguine about the prospects.

ACKNOWLEDGEMENTS

The work described in this paper was variously supported by the Department of the Environment, Welsh Office, Scottish Office, Northern Ireland Office, the Health and Safety Executive, and the Commission of the European Communities. It was performed by various members of staff of the National Radiological Protection Board including R A Algar, K D Cliff, D W Dixon, B M R Green, T D Gooding, P R Lomas, J C H Miles, K Whysall. A list of staff publications on radon is available.

TABLE 1
Nature and structure of UK controls

Circumstance	Commitment	Control
Domestic	Householder, voluntary;	Action Level 200 Bq m ⁻³
	Government, encouragement	Design target ALARP
Occupational	Employer, obligatory;	Dose limit 50 mSv y ⁻¹
	Government, enforcement	Non-action dose 5 mSv y ⁻¹

TABLE 2
Surveys of UK dwellings to early 1992

Type	Purpose	Dwellings
Initial	Discovery of national & regional levels	3,000
Directed	Delineation of some affected areas	7,000
Requested	Satisfaction of public demand	100,000

TABLE 3
Results for UK dwellings to early 1992

Parameter	Value
Arithmetic mean for the United Kingdom, Bq m ⁻³	20
Arithmetic mean in first Affected Area, Bq m ⁻³	100
Highest value observed in dwellings, Bq m ⁻³	10,000
Dwellings discovered above Action Level	12,000
Estimated above Action Level in United Kingdom	100,000

TABLE 4
Statistics for workplaces to early 1992

Parameter	Value
Total number in the United Kingdom	1,700,000
Estimated number in all Affected Areas	50,000
Estimated number subject to regulations	5,000
Number surveyed for radon in the UK	3,000
Number found subject to regulations	300

LE RADON DANS L'ENVIRONNEMENT DE L'HOMME - UNE REVUE DES MESURES
EFFECTUEES EN FRANCE PAR L'IPSN

M.C. Robé, A. Rannou et J. Le Bronec
CEA/Institut de Protection et de Sécurité Nucléaire
Département de Protection de l'Environnement et des
Installations
92265 FONTENAY-AUX-ROSES CEDEX (France)

RADON IN THE ENVIRONMENT AND THE DWELLINGS - A REVIEW OF
MEASUREMENTS CARRIED OUT IN FRANCE BY IPSN

ABSTRACT

Over the last decade, the monitoring of radon gas in various natural environments and regions of France has allowed the IPSN to construct a radon data base. In holes drilled in soils and in underground cavities, radon concentrations between a few hundred $\text{Bq}\cdot\text{m}^{-3}$ and many thousands $\text{Bq}\cdot\text{m}^{-3}$ were measured. Exhalation rates between 10^{-3} and $50 \text{ mBq}\cdot\text{m}^{-2}\cdot\text{s}^{-1}$ were measured in different regions and for different types of soil. In the open air, mean levels were observed in the range of a few $\text{Bq}\cdot\text{m}^{-3}$ to several hundred $\text{Bq}\cdot\text{m}^{-3}$ and concentrations as high as one thousand $\text{Bq}\cdot\text{m}^{-3}$ were measured over short periods.

INTRODUCTION

Le radon est aujourd'hui reconnu comme la source principale d'exposition aux rayonnements pour l'homme. Les travaux effectués en France par l'Institut de Protection et de Sécurité Nucléaire (IPSN) au cours des dix dernières années nous permettent d'apprécier la variabilité des niveaux de radon dans différents milieux, selon les lieux géographiques et les circonstances. Différentes techniques de mesure sont utilisées: ponctuelles, en continu et intégrées. Nous présentons une revue des données concernant la mesure de ^{222}Rn dans les sols, à l'interface entre le sol et l'air, dans l'atmosphère extérieure et dans l'atmosphère des milieux souterrains. Les résultats sont présentés par départements regroupés en régions géologiques, en distinguant les terrains sédimentaires et granitiques.

ACTIVITE VOLUMIQUE DU ^{222}Rn DANS LES SOLS

Des mesures ponctuelles ont été effectuées à l'aide de ballons scintillants dans l'air du sol, de 0,50 à 1 m de profondeur environ (1). Elles indiquent des activités volumiques comprises entre 2 et $420 \text{ kBq}\cdot\text{m}^{-3}$, les valeurs étant en moyenne 5 à 10 fois plus importantes en terrain granitique qu'en terrain sédimentaire (figure 1). Les enregistrements en continu à l'aide de sondes Barasol révèlent en outre des variations temporelles d'un facteur 2 à 3 en un même point, quelle que soit la nature du terrain (1).

FLUX D'EMISSION DU ^{222}Rn à LA SURFACE DU SOL

Les mesures instantanées du flux d'émission de ^{222}Rn (quantité arrivant à l'air libre par unité de surface et par unité de temps) sont faites selon la technique d'accumulation.

En France, les flux observés dans les régions granitiques varient sur 4 ordres de grandeurs (de 1 à 8316 mBq.m⁻².s⁻¹) et peuvent atteindre localement des valeurs très élevées (jusqu'à 50000 mBq.m⁻².s⁻¹ en zone minéralisée) (figure 2). Dans les régions sédimentaires, les flux sont comparables à la valeur de 16 mBq.m⁻².s⁻¹ considérée par le Comité Scientifique des Nations Unies comme représentative du flux moyen à la surface de la terre (2).

ACTIVITE VOLUMIQUE DU ²²²Rn DANS L'AIR EXTERIEUR

Une fois dans l'air extérieur, le radon se dilue en fonction des conditions de diffusion atmosphérique liées à la météorologie et au relief. On observe généralement un gradient de concentration vertical, et des variations temporelles selon un cycle journalier. Le jour, la diffusion atmosphérique est bonne: les concentrations en radon sont relativement faibles. La nuit, se produisent fréquemment des inversions de température: le radon stagne au niveau du sol et sa concentration dans l'air augmente ainsi jusqu'à un facteur 10 à 100 (figure 3a).

Des mesures effectuées en continu pendant 3 années à l'aide d'une chambre d'ionisation ont révélé des moyennes horaires variant sur plusieurs ordres de grandeur en un même lieu (figure 3b). Des écarts significatifs apparaissent entre le jour et la nuit et d'un mois à un autre. Les moyennes annuelles s'avèrent par contre relativement stables sur les 3 années étudiées.

Dans les régions granitiques, les moyennes sur quelques jours (toutes conditions météorologiques confondues) s'échelonnent entre 25 et 210 Bq.m⁻³. Elles sont inférieures à 60 Bq.m⁻³ dans les régions sédimentaires.

ACTIVITE VOLUMIQUE DU ²²²Rn DANS LES CAVITES SOUTERRAINES

Les activités volumiques rencontrées en terrain sédimentaire varient sur plusieurs ordres de grandeur, aussi bien dans les cavités naturelles (de 101 Bq.m⁻³ dans un gouffre du département de la Dordogne à 10876 Bq.m⁻³ dans une grotte de ce même département) que dans les cavités artificielles (moins de 37 Bq.m⁻³ dans le Métro Parisien à 5070 Bq.m⁻³ dans les Catacombes à Paris).

Les niveaux mesurés en terrain granitique sont plus élevés en moyenne: de 942 à 1592 Bq.m⁻³ dans un gouffre en Corrèze et de 400 à 1600 Bq.m⁻³ dans un musée souterrain installé dans une ancienne mine d'argent du département des Deux-Sèvres.

DISCUSSION ET CONCLUSION

Les mesures de ²²²Rn effectuées en France montrent la présence de ce gaz dans tous les milieux de notre environnement. Les 4 paramètres étudiés, c'est-à-dire radon dans le sol, à l'interface entre le sol et l'air, dans l'air extérieur et dans les milieux souterrains, varient très fortement selon les lieux géographiques et le moment.

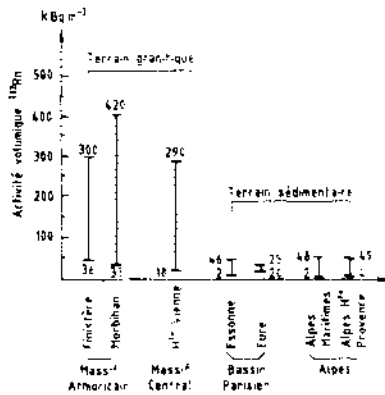

Figure 1- Activité volumique du ^{222}Rn dans les sols de différents départements français.

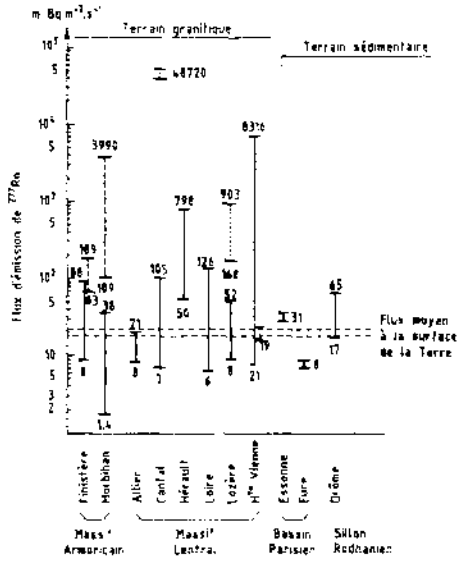

Figure 2- Flux d'émission de ^{222}Rn à la surface du sol dans différents départements français.

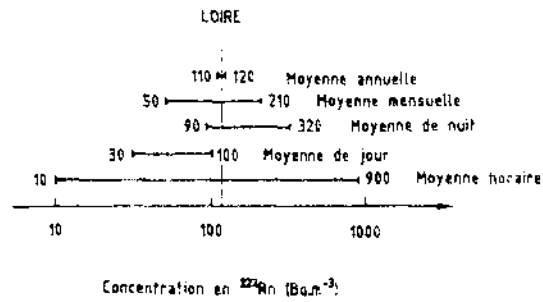
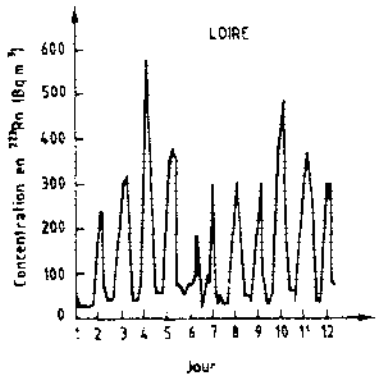

Figure 3 - Activité volumique du ^{222}Rn dans l'air extérieur à Saint-Priest-la-Prugne (département de la Loire):
 a) enregistrement en continu au mois de juillet 1983
 b) valeurs moyennes pendant différentes périodes d'observation, d'après une mesure en continu en 1983, 1984 et 1985.

Les différents résultats obtenus dans une région donnée forment cependant un ensemble de données cohérentes et représentatives de la région (tableau 1).

	Granitique			Sédimentaire
	Finistère	Morbihan	Haute-Vienne	Région Parisienne
Débit de dose γ dans l'air ($n\text{Gy}\cdot\text{h}^{-1}$) (a)	75	90	120	49
^{226}Ra dans les sols ($\text{Bq}\cdot\text{m}^{-3}$)	52-137	83-214	134-292	35
^{222}Rn dans les sols ($\text{Bq}\cdot\text{m}^{-3}$)	36-300	33-420	18-290	2-46
flux d'émission par le sol ($\text{mBq}\cdot\text{m}^{-2}\cdot\text{s}^{-1}$)	8,4-88,2	1,4-37,8	21-8316	7,7-31,5
^{222}Rn dans l'air extérieur ($\text{Bq}\cdot\text{m}^{-3}$)	8-300	10-370	20-1000	8-120
^{222}Rn dans les maisons ($\text{Bq}\cdot\text{m}^{-3}$) (b)	99	87	123	25

(a) moyenne arithmétique

(b) moyenne géométrique (mesures intégrées)

Tableau 1. Activité massique du ^{226}Ra dans les sols, débit de dose γ dans l'air et différents paramètres liés au ^{222}Rn dans 3 départements français granitiques et la région Parisienne sédimentaire.

En toute logique, les activités volumiques moyennes en ^{222}Rn dans les habitations sont conformes à cet ensemble de données. Elles sont plus élevées dans les régions granitiques que celles sédimentaires, d'un facteur 4 à 5 environ, comme pour chacun des paramètres mesurés dans les autres milieux. C'est sur ces multiples données que peuvent s'appuyer les diagnostics radon⁽³⁾ et les études sur la potentialité des sols en radon.

REFERENCES

1. Robé, M.C., Rannou, A., Le Bronec, 1991, Radon in the environment in France, communication au Fifth International Symposium on the Natural Radiation Environment, Salzburg, 22-28 septembre 1991.
2. UNSCEAR, 1988, Sources and Effects of Ionizing Radiation, United Nations Scientific Committee on the Effects of Atomic Radiation, 1988 report of the General Assembly with annexes, New-York.
3. Robé, M.C., Rannou, A., Le Bronec and Tymen, G., 1991, Le radon dans les habitations: identification des sources et des voies de transfert, congrès IRPA8, Montréal, 17-22 mai 1992.

Mesure des nouvelles grandeurs opérationnelles à l'aide des appareils
de radioprotection destinés à la surveillance des zones de travail
et à la surveillance individuelle

R. PRIGENT* - J. CHARY* - M. CHEMTOB* - Y. HERBAUT** - Ph. LEBOULEUX*

CEA / Institut de Protection et de Sécurité Nucléaire
Département de Protection de l'Environnement et des Installations
B.P. n° 6 - 92265 Fontenay-aux-Roses - Fax : 42 53 91 25

Measurement of new operational quantities with radiation protection
instruments designed for working area monitoring and for
individual monitoring

The ICRP recommended a dose limitation system based on numerical evaluation of the dose equivalent to organs or tissues, H_T , which are used to calculate the effective dose, H_E , by weighting. The ICRU proposed new operational quantities accessible to measurement which are conservative with respect to these recommendations. The objective of this paper is to recall briefly the basic recommendations and to find out if radiation protection instruments presently used calibrated in terms of the previous quantities are capable to measure these new quantities. A dozen of practical cases are presented.

RESUME

L'ICRP a recommandé un système de limitation des doses basé sur l'évaluation numérique de l'équivalent de dose dans certains organes ou tissus, H_T , pour accéder, après pondération à l'équivalent de dose efficace, H_E . Le but de cette communication est d'une part de rappeler brièvement les recommandations de base et d'autre part d'examiner si les appareils de radioprotection actuellement utilisés en France et étalonnés dans d'anciennes grandeurs sont aptes à mesurer ces nouvelles grandeurs. Une douzaine de cas pratiques sont traités.

I. INTRODUCTION

L'International Commission on Radiation Units and measurements dans son rapport ICRU de 1985 n° 39 intitulé "Détermination des équivalents de dose dus aux sources externes de rayonnements" donne les définitions des grandeurs à employer pour le contrôle des rayonnements ionisants, grandeurs qui servent de base à la radioprotection opérationnelle pour mettre en place dans la pratique les recommandations de l'ICRU (rapports 25 et 33). Ce même rapport expose ensuite dans son introduction son but qu'il est bon de rappeler :

- lorsque des personnes sont exposées aux rayonnements ionisants, il est généralement nécessaire de spécifier le niveau d'exposition externe en termes numériques. Ceci est exigé pour assurer une radioprotection réelle et pour montrer que les limites réglementaires sont respectées. La Commission Internationale de Protection Radiologique (CIPR) a recommandé un système de spécifications numériques fondé sur la somme pondérée des équivalents de dose reçus dans divers organes : l'équivalent de dose efficace, H_E . Ces équivalents de dose ne peuvent, dans la plupart des cas, être directement mesurés et, par conséquent, doivent être évalués à partir de ce que l'on sait mesurer.

(*) IPSN / DPEI / Fontenay-aux-Roses - (**) SFR / Grenoble

S'agissant du contrôle pratique de l'irradiation externe par des appareils de surveillance des zones de travail et par des appareils de surveillance individuelle, des grandeurs directement mesurables appelées "grandeurs opérationnelles" (H^* (10), H' (0,07) pour la surveillance des zones de travail et H_p (10), H_s (0,07) pour la surveillance individuelle) seront utilisées pour évaluer de façon la plus correcte possible (sans sous-évaluation ou surestimation excessive) l'équivalent de dose efficace.

II. CARACTERISTIQUES SOUHAITABLES DES INSTRUMENTS UTILISES POUR LA SURVEILLANCE DES ZONES DE TRAVAIL (AMBIANCE)

II.1 Equivalent de dose ambient H^* (10)

Les instruments destinés à la mesure de H^* doivent présenter une réponse isotrope. Ces appareils qui ont une réponse isotrope et qui sont étalonnés en terme de H^* mesureront H^* dans n'importe quel champ de rayonnement uniforme dans un volume au moins égal à celui qui est occupé par l'appareil. La définition de H^* implique que l'appareil soit conçu de telle façon qu'il tienne compte du rayonnement rétrodiffusé dans la sphère de référence.

II.2 Equivalent de dose directionnel H' (0,07)

Les instruments destinés à la mesure de H' sont conçus pour des rayonnements faiblement pénétrants provenant d'un angle solide 2π stéradians. Ils doivent donc répondre correctement, non seulement aux rayonnements d'incidence normale à la face d'entrée de l'instrument, mais aussi aux rayonnements d'incidence oblique (les normes CEI spécifiques définissent les limites de variations tolérées pour leurs caractéristiques principales).

III. CARACTERISTIQUES SOUHAITABLES DES INSTRUMENTS UTILISES POUR LA SURVEILLANCE INDIVIDUELLE

III.1 Equivalent de dose individuel en profondeur H_p (10)

Les instruments destinés à la mesure de H_p sont conçus pour des rayonnements fortement pénétrants provenant d'un angle solide 2π stéradians.

III.2 Equivalent de dose individuel en surface H_s (0,07)

Les instruments destinés à la mesure de H_s sont conçus pour des rayonnements faiblement pénétrants provenant d'un angle solide 2π stéradians.

Les instruments destinés à la mesure de H_p et H_s sont conçus pour être portés à la surface du corps. Celui-ci assure donc la production du rayonnement rétrodiffusé. Ils doivent répondre correctement aux rayonnements d'incidence normale à la face d'entrée de l'instrument, mais aussi aux rayonnements d'incidence oblique (les normes CEI spécifiques définissent les limites de variations tolérées pour leurs caractéristiques principales).

IV. ETALONNAGE DES INSTRUMENTS

- les instruments destinés à la mesure de H^* (10) et H' (0,07) sont étalonnés dans l'air. Les coefficients de conversion du kerma dans l'air aux grandeurs H^* (10) et H' (0,07) sont donnés dans (1).

- les instruments destinés à la mesure de H_p (10) et H_s (0,07)

sont étalonnés sur un fantôme approprié :

- soit une sphère de 30 cm de diamètre constituée d'un matériau équivalent tissu (2).

- soit une plaque de dimensions 30 cm x 30 cm x 15 cm d'épaisseur d'un matériau équivalent tissu (3)

Suivant le fantôme utilisé, on appliquera les coefficients de conversion spécifiques (3).

V. RESULTATS D'ESSAIS SUR PLUSIEURS APPAREILS DE RADIOPROTECTION DESTINES A LA MESURE DES RAYONNEMENTS γ (ETALONNAGE, REPONSE EN FONCTION DE L'ENERGIE, REPONSE ANGULAIRE)

La présentation "poster" porte sur une douzaine d'appareils équipés de détecteurs différents (chambre d'ionisation de différentes épaisseurs, tube Geiger-Muller, détecteur en silicium) à partir de graphes dont les résultats seront comparés aux normes existantes de la CEI.

Les étalonnages de ces appareils ont été effectués de façon systématique dans les anciennes et nouvelles grandeurs afin de connaître leur comportement et principalement leur réponse en fonction de l'énergie et leur réponse angulaire. Ces essais ont permis de connaître l'aptitude des appareils actuels à effectuer des mesures dans les nouvelles grandeurs et d'envisager les actions correctives à apporter pour les mettre en conformité ou à la limite ne pas les recommander s'il s'avère qu'ils ne peuvent pas être adaptés.

Par ancienne grandeur nous entendons pour la France la dose absorbée $D_{(3)}$ dans les tissus mous sous 300mg.cm^{-2} . Dans un domaine d'énergie de 10 keV à 3 MeV elle peut être déduite du kerma dans l'air à l'air libre, K_a , si l'on néglige le rayonnement de freinage. Cette grandeur avait été retenue en prenant le cristallin comme organe critique pour le risque.

Jusqu'à présent les appareils français destinés à la surveillance des zones de travail ou à la surveillance individuelle étaient étalonnés dans l'air et leur réponse devait être isotrope dans les 4π steradians.

Ce document ne présente que deux exemples :

- un appareil de surveillance des zones de travail dont le détecteur est une chambre d'ionisation (figure 1),
- un appareil de surveillance individuelle équipé d'un détecteur au silicium (figure 2).

VI - CONCLUSION

La conclusion générale est que la plupart des appareils actuellement en service peuvent être utilisés pour mesurer les grandeurs opérationnelles au prix le plus souvent d'un simple changement d'échelle et plus rarement d'une adaptation des écrans de correction entourant le détecteur en se satisfaisant de leur réponse angulaire actuelle.

BIBLIOGRAPHIE

1. CEI 846 (1989) - Mesureurs d'équivalent de dose et de débit d'équivalent de dose, bêta, X et gamma, utilisables en radioprotection.
2. ICRU - Rapport 33 (1980)
3. CEI 45B (Secrétariat) 104F (1991) - Moniteur individuel à lecture directe d'équivalent de dose et/ou de débit d'équivalent pour les rayonnements X, gamma et bêtas d'énergie élevée.

REPONSE EN FONCTION DE L'ENERGIE

Appareil de surveillance de l'ambiance

- BABYLINE 91 (Chambre d'ionisation de 500 cm³)

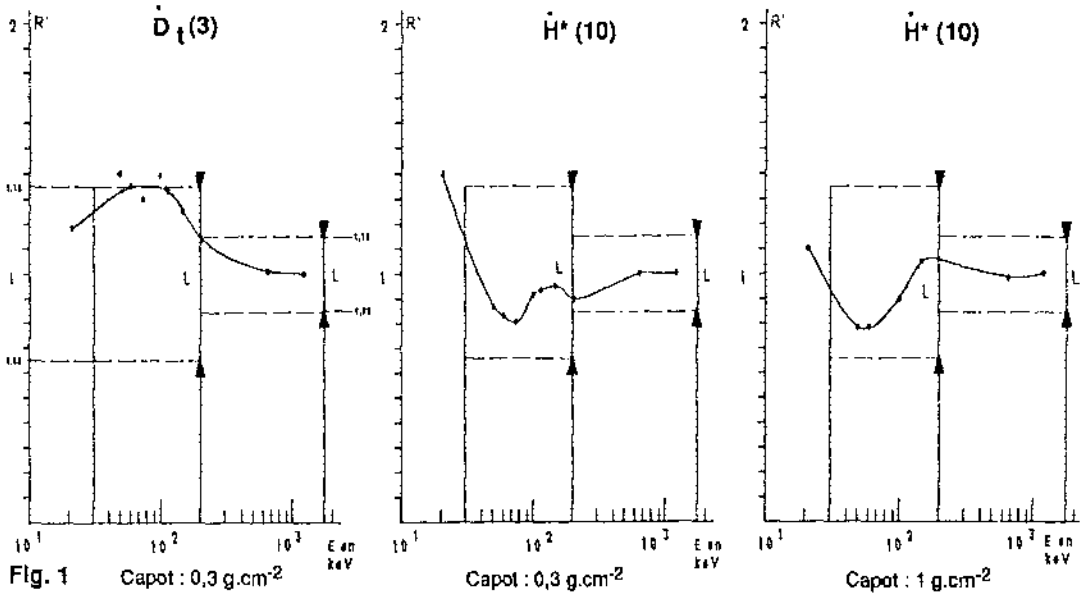

Appareil de surveillance individuelle

- DM71 - DM61 (Détecteur au silicium)

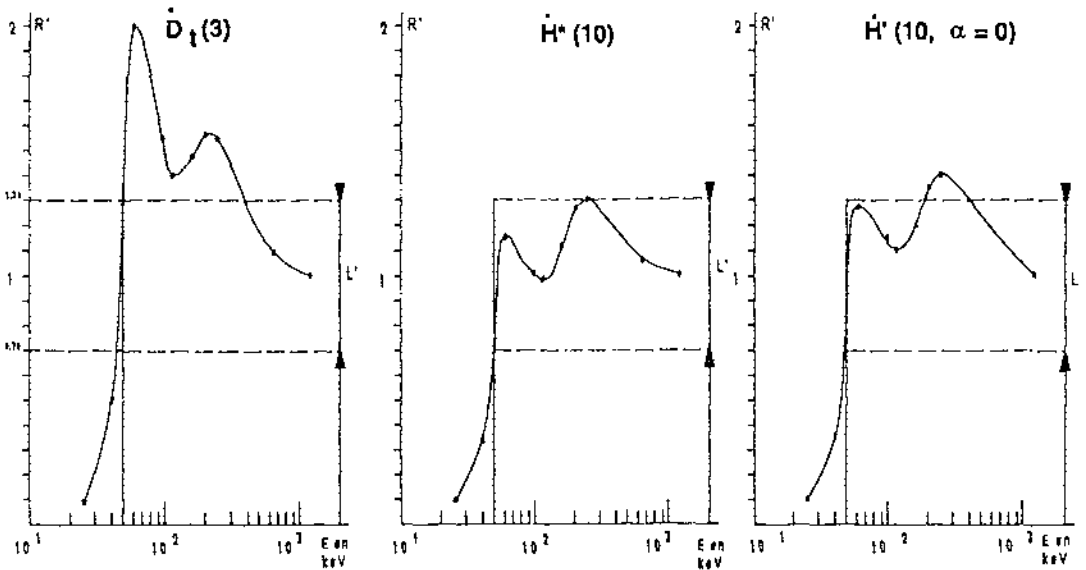

POTENTIAL RISK OF THORON AND ITS PROGENIES IN THE AIR OF TRADITIONAL JAPANESE WOODEN HOUSES

Masahiro Doi, Sadayoshi Kobayashi and Kenzo Fujimoto
Safety Analysis Unit, National Institute of Radiological Sciences
9-1, Anagawa-4, Chiba 260, JAPAN

Abstract

A new type of passive dosimeter has been developed, which can measure radon and thoron concentrations separately. Detailed measurement using the radon-thoron differential detectors thus developed revealed that thoron concentration indoors in some selected houses has a distribution to decrease significantly as the distance from the interior soil wall increases. Interim measurements on Hiroshima houses ascertained that some Japanese wooden houses with traditional Japanese interior soil walls may have enhanced thoron concentration indoors.

Introduction

A national survey of indoor radon concentration in Japan was commenced in 1985, and covered 6,300 houses throughout Japan¹⁾. Karlsruhe passive radon detectors²⁾ were used in the survey, in view of the fact that it had already been used in many countries at the time when the project was initiated and hence international comparison was possible. The indoor radon concentration showed a median value of 23 Bq/m³ whose distribution was log-normal with a geometric standard deviation of 1.6¹⁾. Statistical analysis on the type of buildings and indoor radon concentration revealed that the extreme values of high concentration were found mostly in wooden houses especially of traditional Japanese style. It should be noted that the dosimeter employed in the survey registers α -tracks from thoron (²²⁰Rn) as well as radon (²²²Rn), if they exist in the same ambient air. Since traditional Japanese houses have interior soil walls, one of the causes of apparently higher concentration was suspected to be due to thoron concentration from the building materials. In order to carry out an analysis on indoor thoron concentration as well as radon's, a new type of passive dosimeter was developed which can estimate radon and thoron concentrations differentially³⁾. The results of interim measurement on some houses with elevated radon and thoron concentration are presented.

Method of the measurement

An illustration of the passive radon-thoron differential detector²⁾ is shown in **Figure 1**. The

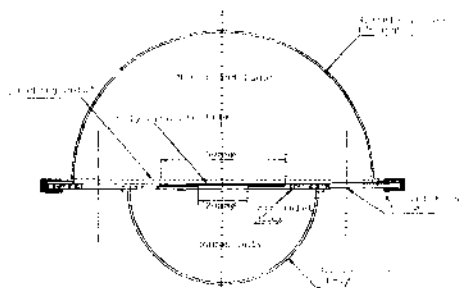

Figure 1 Schematic Figure of the passive radon-thoron differential detector

placed in each of the two hemispheric chambers. One polycarbonate film faces the inside of the large chamber, and another the inside of small chamber. Eight air inlets are provided on the stainless disk, which are covered by glass fiber filters in order to prevent decay products from entering the detector housing. Since the air exchange rate of these air inlets is 15.89 times per hour, 99% of gaseous radon and 26% of gaseous thoron are able to intrude into the large chamber. Gaseous radon and thoron in the large chamber diffuse into the small chamber through a pinhole inlet (1mm ϕ) on a inner stainless disk at the air exchange rate of 0.38 times per hour. Because of its short half life (55 sec), only 0.2% of thoron gas diffuse into the small chamber.

After the exposure to the atmosphere for 2 months, the polycarbonate film placed in the large chamber is subjected to preliminary chemical etching for 3 hrs which is performed at 30 °C with a blend of 8.0N KOH solution (80% by volume) and C₂H₅OH (20%) and following electrochemical etching for 3 hrs under AC800V, 2kHz. The radius of the hemisphere is large (60mm), and the duration of preliminary chemical etching is long (3hrs) enough to discriminate low energy α -particles whose ranges in polycarbonate film are so short that they can not reach the depth of electrochemical etching layer. In this condition, α -particles emitted by thoron and thoron daughters are registered as electrochemical etch pits dominantly. In contrast, the polycarbonate film in the small chamber is subjected to preliminary chemical etching for only 0.5 hrs and following electrochemical etching for 3 hrs. The radius of the hemisphere is small (37.5mm), and the duration of preliminary chemical etching is short (0.5 hrs) enough to discriminate high energy α -particles whose ranges in polycarbonate film are so long that they overstep the depth of the electrochemical etching layer. In this condition, α -particles emitted by radon and radon daughters are registered as electrochemical etch pits mainly.

detector housing is made of stainless steel, which has two hemispherical chambers, whose diameters are 120 mm and 75 mm respectively. Two hemispheric chambers cover the detector holder from the up and down sides, being combined into a shape of a flying saucer. One sheet of disk-shaped polycarbonate film (Iupilon S-2000, Mitsubishi Gas Chemical Co., Ltd., Japan, 50 mm in diameter, 300 μ m in thickness) is

Films	Conversion factor Tracks cm ⁻² /(Bqm ⁻³ day)	
	Radon	Thoron
PC film in 120mm chamber	0.0299 \pm 0.0017	0.0127 \pm 0.0022
PC film in 75 mm chamber	0.0395 \pm 0.0053	0.0000 \pm 0.0000

Table 1 Summary of conversion factors (Tracks cm⁻²/(Bqm⁻³day)) for radon and thoron exposures determined by calibration exercises.

Conversion factors from etch pit density into radon and thoron concentration are shown in **Table 1**. Calibration exercises were performed using a standard ra-

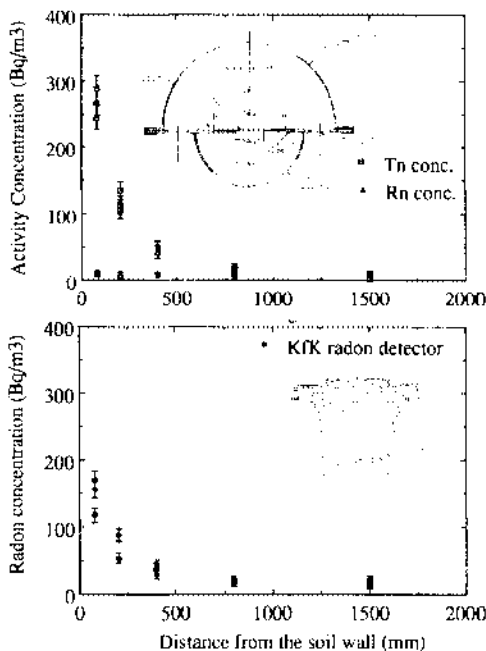

Figure 2 Distributions of indoor radon and thoron concentration in a traditional wooden house in Kyoto Prefecture by radon-thoron differential detector (upper figure) and that of "radon" concentration by Karlsruhe radon detector (lower), for the period from June to August, 1991.

contrast, thoron concentration distributes in a wide range: it decreased significantly as the distance from the soil wall increased. Since thoron concentration varies so significantly according to the place in the room, the point of the measurement must be taken into account to estimate the thoron concentration indoors. Distribution of radon concentration estimated by Karlsruhe radon detector²⁾ is also shown in **Figure 2** (lower figure). It is ascertained that the Karlsruhe radon detector²⁾ responded to thoron contribution.

An interim survey using passive radon-thoron differential detectors was performed on 42 rooms of 21 houses in Hiroshima Prefecture. These houses were regarded as high radon risk houses by previous national survey¹⁾. Each detector was posi-

tioned in a radon chamber of the U.S. Environmental Protection Agency and a standard thoron chamber of Waseda University, Japan. Detailed specification of the detector was presented elsewhere³⁾.

Results and discussions

Detailed measurements were performed using radon-thoron differential detectors at some traditional Japanese wooden houses with interior soil wall in Kyoto Prefecture. Detectors were placed at five different distances, three at each distance in total of 15, from the surface of soil wall. Each detector was coupled with a Karlsruhe passive radon detector²⁾. Distributions of radon and thoron concentrations are shown in **Figure 2** (upper figure). Radon concentration was $8.8 \pm 1.6 \text{ Bq/m}^3$, whose distribution is almost uniform. In con-

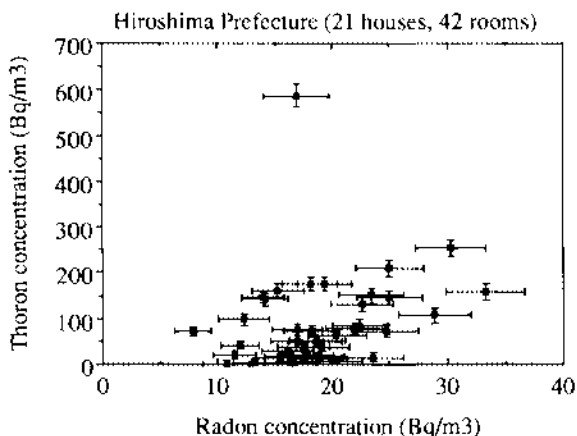

Figure 3 Radon and thoron concentration in 42 rooms in 21 houses in Hiroshima Prefecture, estimated by passive radon-thoron differential detectors. Measurement period was June-August, 1991.

tioned at the same place where Karlsruhe radon detector²⁾ was placed in the previous survey¹⁾. Therefore, the distance from the soil wall to the detector differed by each house from 40mm to 800mm. Results of the measurement are shown in **Figure 3**. Radon concentration ranges from 7.80 Bq/m³ to 33.3 Bq/m³, and thoron concentration from N.D. to 587 Bq/m³. There is no correlation between radon and thoron concentration. The median value of indoor radon concentrations in the Hiroshima houses was estimated as 56.7 Bq/m³ (median) by Karlsruhe radon detector²⁾ from April to September, 1991. Whereas it was shown by use of the radon-thoron differential detector³⁾ that they have radon concentration of 18.3 Bq/m³ (median), plus thoron concentration of 57.4 Bq/m³ (median). Since about 70 % of Japanese houses are wooden house according to the national statistics⁴⁾, indoor thoron concentration needs to be investigated in detail especially on wooden houses with traditional interior soil walls in order to identify potential risk of thoron and its progenies indoors as well as radon's.

Conclusion

A new type of passive dosimeter has been developed, by which radon and thoron concentrations can be measured separately at a same time. Thoron indoors in some selected Japanese houses with interior soil walls showed a gradient distribution of concentration in such a way as it decreases significantly as the distance from the interior soil wall increases. Interim measurements on Hiroshima houses ascertained that some Japanese wooden houses with traditional interior soil walls may have extremely enhanced thoron concentration indoors.

Acknowledgments

Authors would like to express their hearty appreciation of the assistance given by Prof. Kurosawa of Waseda University, Japan who kindly made available the use of thoron chamber for calibration exercise. They also wish to thank Mr. Sensintaffar and his staffs of U.S. EPA and Mr. George of U.S.DOE for their kind help in carrying out the radon calibration exercise.

References

- 1) Kobayashi, S. et al. Nationwide survey of Indoor radon concentration in Japan. Proceedings of 3rd International Symposium of Environment, Mito, Japan (1991).
- 2) Urban, M. and Piesch, E. Low Level Environmental Radon Dosimetry with a Passive Track Etch Detector Device. *Radiat. Prot. Dosim.*, **1**, pp97-109 (1981).
- 3) Doi, M., Kobayashi, S. and Fujimoto, K. A Passive Measurement Technique for Characterization of High Risk Houses in Japan due to Enhanced Level of Indoor radon and Thoron Concentration. Proceedings of the Fifth International Symposium on the Natural Radiation Environment, In press (1991).
- 4) Statistics Bureau, Management and Coordination Agency. Housing of Japan (1991).

THE LEGAL SITUATION OF RADON IN SWEDEN

Lars Persson

Swedish Radiation Protection Institute
Box 60204, S-10401 Stockholm, Sweden

ABSTRACT

The Swedish Local Authorities are responsible for decreasing the radon concentration in homes. The National Board of Health and Welfare regulates and supervises this programme. The National Board of Occupational Safety and Health regulates the radon levels in mines. The National Board of Housing, Building, and Planning regulates the upper level of radon indoor in newly built houses. The Swedish Radiation Protection Institute is responsible for measuring techniques and risk assessments of radon.

INTRODUCTION

Due to the natural conditions (U-rich ground, Ra-rich building materials, and the cold climate), there often exists high levels of radon and its decay products in the air of houses, mines and other working places in Sweden. The work to reduce the levels of radon started with the improvement of the ventilation of the mines in the late 1960's. During the 1970's the interest was focussed on houses and indoor air.

PUBLIC INVESTIGATIONS

In 1979 the Swedish Government authorized the Minister of Agriculture to appoint an investigator to study the question of countermeasures against radiation risks in buildings. The investigation was carried out by The Radon Commission. The Commission submitted its final report to the Swedish Government in January 1983 (1).

Most of the Commission's work was devoted to practical issues connected with radon in housing. The radon problem in Sweden was originally considered to derive from building materials containing radium. The measuring activities performed by the Local Authorities and a nationwide investigation of the occurrence of radon in housing by the Swedish Radiation Protection Institute indicated the ground as the principle source of radon. The number of buildings, in which the radon daughter concentration exceeded 400 Bq/m^3 , was estimated to be about 40 000. In Sweden the limits are given as annual averages of the Equilibrium Equivalent Concentration of Radon (EER), also called the radon daughter level.

The Commission proposed a radon daughter action level of 400 Bq/m^3 , and that homeowners be provided with possibilities of obtaining special loans for financing countermeasures if the radon levels exceeded this figure. The Commission also proposed that the National Board of Health and Welfare and the National Board of Housing, Building and Planning, in collaboration with the Swedish Institute of

Radiation Protection, should undertake the responsibility that the Local Authorities receive information and directives concerning radiation in buildings. The Commission proposed that research in the radon protection field should be carried out or supported by the Swedish Institute of Radiation Protection and the National Council for Building Research.

The Swedish Government decided in 1985 to follow the main recommendations of the Radon Commission. The Government's decision was now also based on the proposals and risk estimates of the Swedish Cancer Committee, which in 1984 submitted its report (2) to the Government.

The Swedish Committee for Revision of the Radiation Protection Legislation submitted in 1985 its report (3) to the Government. The Committee proposed that the new law should cover also natural radiation sources such as radon. The tasks of the Swedish Radiation Protection Institute with respect to natural radiation should be the development and standardization of measuring techniques and methods and the risk assessment of radon. It was also proposed that the law should grant authorization to the Radiation Protection Institute to impose directives with respect to measuring and protective equipment as well as testing, supervision or inspection of natural radiation. The Swedish Parliament accepted these proposals in 1988 (4).

NORDIC CO-OPERATION IN THE RADON FIELD

There exists a close cooperation in the radiation protection field between the five Nordic countries and its radiation protection authorities (5). A working group with the aim of developing radiation protection recommendations for natural radiation in the Nordic countries was set up by the radiation protection institutes in Denmark, Finland, Iceland, Norway, and Sweden. The working group reported in 1986 its recommendations (6). The main recommendation of the working group was that the action level for existing houses should not be higher than 400 Bq/m³ radon daughters. If the radon daughter concentration exceeded this value in a house, remedial action to bring the concentration down to a level as low as reasonably achievable should generally be an obligation. The possibilities for remedial action with financial support from the authorities should also be considered, if the radon daughter concentration exceeded 100 Bq/m³.

PRESENT RISK ASSESSMENT AND LEGAL SITUATION

The risk assessment for radon made by the Swedish Radiation Protection Institute (7) is based upon ICRP's principles for limiting exposure to natural radiation sources (8). The recent Swedish experience in radon control has been reviewed by Swedjemark and Maekitalo (9) and the Swedish view on radon control by Mjoenes (10).

Several authorities and different laws are involved in the field of radon protection in Sweden as follows:

* The Swedish Local Authorities are responsible for decreasing the radon daughter concentration in the homes and working places other than mines in each municipality. These authorities act according to the Health Protection Legislation. In 1990 the action level for remedial measures of existing buildings and working places has been decreased to 200 Bq/m³ radon daughters by the National Board of Health and Welfare according to an authorization by the Government (11). For houses with radon daughter levels between 70 and 200 Bq/m³ simple remedial actions should be carried out. The Board of Health and Welfare supervises the indoor radon gas remedial programme.

* The National Board of Occupational Safety and Health in 1986 issued a regulation on rock work (underground work) with an upper exposure limit of 2 MBqh per m² and year for the radon daughter exposition (12).

* The National Board of Housing, Building and Planning has issued a regulation on the permitted upper level of radon indoor in newly built houses based on the Act on Planning and Building (13). The radon daughter level must be lower than 70 Bq/m³. The health risk from radon must be taken into account in the building planning process. The Board has thus recommended that the Local Authorities and builders ensure that they take into account the risk of radon from the ground, when planning for building and the use of land (14). For planning purposes the ground should be classified into high, normal and low risk areas. This classification should be based on geological criteria but it must also be related to building structure. For details see ref. (9).

* The Radiation Protection Law (4) also covers natural radiation including radon. According to this act the Swedish Radiation Protection Institute is responsible for target-oriented research and monitoring of international developments, risk assessment and principles of risk management, recommendations concerning limits on activities and doses for the implementation of certain measures, development and standardization of measuring techniques and methods, requirements concerning testing and inspection of measuring techniques and equipment, and consultation and provision of information on injuries that may be caused by radon.

REFERENCES

1. Swedish Radon Commission, 1983, Radon in housing (in Swedish), Swedish Public Investigations SOU 1983:6, Liber AB Allmaenna Foerlaget, Stockholm. A summary in English of the report exists as Document a84-10 issued by the Swedish National Institute of Radiation Protection.
2. Swedish Cancer Committee, 1984, Cancer - origins, prevention etc. (in Swedish), Swedish Public Investigations SOU 1984:67, Liber AB Allmaenna Foerlaget, Stockholm (a summary in English is included in the report).
3. Swedish Committee for Revision of the Radiation Protection Legislation, 1985, New Radiation Protection Law (in Swedish),

Swedish Public Investigations SOU 1985:58, Liber Allmaenna Foerlaget, Stockholm .

4. Swedish Government, 1988, Proposal 1987/88:88 to the Parliament concerning a new radiation protection law etc. (in Swedish). Swedish Parliament's printed documents 1977/78, 1 collection no 88 (a summary of the legislation is available from the Swedish Radiation Protection Institute as SSI-Report 91-10).

5. Persson, L., 1987, Radiation protection and atomic energy legislation in the Nordic countries, Swedish Radiation Protection Institute, Report 87-34.

6. The Radiation Protection Institutes in Denmark, Finland, Iceland, Norway, and Sweden, 1986, Naturally occurring radiation in the Nordic Countries - recommendations (available from the mentioned institutes).

7. The Swedish Radiation Protection Institute, 1987, Information on radon daughter levels - radiation dose - risk for lung cancer (in Swedish), 187-01 (available from the Institute).

8. International Commission on Radiological Protection, 1983, Principles for Limiting Exposure of the Public to Natural Sources of Radiation ICRP no 39, Annals of the ICRP 14, 1, 1984, Pergamon Press, Oxford.

9. Swedjemark, G. A. and Maekitalo, A., 1990, Recent Swedish experiences in Rn-222 control, Health Physics 58, 4, pp. 453-460.

10. Mjoenes, L., 1991, The Swedish view on radon control, presented at the conference Measurement of radon and its decay products, Berlin, May 6-7 1991.

11. Swedish National Board of Health and Welfare, 1990, Radon and public health protection - General advice from the National Board of Welfare 1990:5 (in Swedish), Allmaenna Foerlaget, Stockholm.

12. Swedish National Board of Occupational Safety and Health, 1986, Rock work, AFS 1986:17 (in Swedish), Liber Distribution, Stockholm.

13. Swedish National Board of Housing and Planning, 1988 and 1990, Regulations and general advice on new construction of houses, 1988:18 revised 1990:28 (in Swedish), Allmaenna Foerlaget, Stockholm.

14. Swedish National Board of Housing and Planning, 1982, Planning, building licences and protective measures (in Swedish), Report 59, Svensk Byggtjaenst, Stockholm.

**INDOOR RADON CONCENTRATIONS IN
SOUTH AFRICAN HOMES**
A H Leuschner, A Steyn, R Strydom, G P de Beer
Atomic Energy Corporation of South Africa Limited
P O Box 582, Pretoria 0001, South Africa

ABSTRACT

Radon concentrations have been measured in about 2 000 South African houses during a phased study. The winter-month average was 63 Bq/m³ and the geoemetric mean 45 Bq/m³. Parameters correlating with high indoor radon concentrations were floor type and uranium content of geological formation.

INTRODUCTION

The radiation dose from inhaled decay products of radon seems to be the dominant component of radiation exposure of the world population. Although much can be learnt from overseas experience, local differences warrant an investigation of the South African situation. On the one hand the South African climate may favour better ventilation conditions which may result in lower indoor radon concentrations. On the other hand the cold Highveld winters and lack of central heating may promote stagnant indoor conditions for certain months of the year. Furthermore, the densely populated areas on the Witwatersrand are surrounded by waste dumps from gold/uranium mines. These contain enhanced ²²⁶Rn concentrations. The Department of National Health and Population Development and various town and city councils provided financial and logistic support for this study.

OBJECTIVES AND PHASES OF THE STUDY

The main objective was to assess the magnitude of the public exposure to indoor radon concentrations through nationwide surveys as extensive as possible, in accordance with requirements and resources available.

The study was conducted in three phases. The first phase was conducted in 1988 in a few areas to obtain initial logistic and sampling experience and to evaluate the techniques. The second phase during the winter of 1989 evaluated randomly selected houses of AEC employees and areas selected from an airborne radiometric survey, granitic areas, and an area that showed a geological fault and high indoor radon concentrations. In the third phase the study was expanded to other areas, including an area where indoor burning of coal might contribute to high indoor radon levels.

METHOD AND PROCEDURES

In order to obtain representative concentrations for average conditions, it is necessary to perform integrated measurements over days or preferably even months. No consideration is given to diurnal patterns or the equilibrium factor of the radon. These factors should be the subject matter of later studies.

SAMPLING TECHNIQUES

All the studies were performed primarily during the winter months. Time-integrating passive samplers were used. Charcoal canisters (Cohen *et al*, 1986) were used in some early investigations but this method of sampling was discontinued. Nuclear-track (or track-etch) detectors (Urban *et al*, 1981) were used for sampling. These monitors were normally exposed for three months. After electrochemical etching of the films the tracks were counted using a computer-automated technique.

DATA COLLECTION

Together with each measurement a one-page questionnaire was administered to obtain information about the house. This information was finally combined with that of the area characteristics and the radon concentrations in a computer data base.

DATA ANALYSIS

Data analysis was aimed at determining the relationship between indoor radon concentrations and house characteristics and the area characteristics. Analyses of variance (ANOVA) were determined for four effects, namely ventilation, sub-floor type, floor type and geographical type.

Poor ventilation is represented by a level 0 and high ventilation by level 5. Sub-floor level of 0 indicated normal soil, level 1 filling with rubble with large pores, level 2 a basement or crawl space and level 3 filling with mine tailings. Floor type level 0 indicated wooden floor or no floor covering and 1 concrete slab. Geographical types were assigned level 0, 1 or 2, where 0 indicated geological type with relatively low uranium concentrations, 1 indicated uncertain or variable uranium concentrations and 2 relatively high uranium concentrations. This evaluation indicated that the areas selected were not significantly biased towards high-uranium geological types.

RESULTS

The sample size was 1 801 houses, the total averaging was 63 Bq/m^3 , the median 52 Bq/m^3 , the mode 39 Bq/m^3 and the geometric mean 45 Bq/m^3 .

The measured indoor radon concentrations are shown in Figure 1.

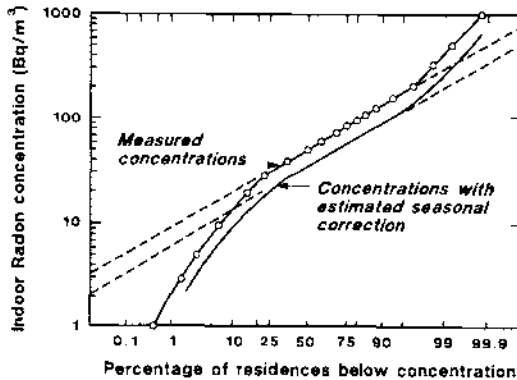

Figure 1: Log-normal distribution of Indoor Radon Concentrations in South Africa

It should, however, be noted that the measured values do not represent seasonally-, construction- and locality-averaged values. Outdoor measurements indicated a winter- to annually-averaged ratio of 1,5. (This approximates ratios reported for the USA [Borak, *et al*, 1989].) Dividing the winter-measured values by 1,5 gives the lower curve in Fig. 1.

Table 1 gives the indoor radon concentrations for the various areas.

Table 1: Median and Range (Bq/m³) for each Town in Compounded Data Set

Town	Sample Size	Median	Geometric Mean	Average	Maximum
Cape Town	134	10	9	13	52
Bedfordview	16	23	4	20	72
Malmesbury	59	25	24	42	150
Richards Bay	76	33	26	38	120
Rustenburg	10	34	31	33	48
Parys	44	37	41	66	595
Brits	30	38	35	42	119
Paarl	60	39	45	85	842
Johannesburg	284	45	37	49	197
Stilfontein	72	45	50	62	131
Sandton	16	46	46	50	106
Roodepoort	6	50	49	61	130
Akasia	7	52	51	57	97
Soweto	150	54	53	56	131
Hartbeespoort	28	56	49	59	145
Boksburg	116	56	59	66	212
Verwoerdburg	29	57	55	61	136
George	91	60	55	64	143
Pretoria	148	61	54	66	197
Phalaborwa	8	62	60	61	79
Krugersdorp	53	65	67	77	273
Springbok	67	70	60	78	340
Beaufort-West	62	74	61	79	184
Nababeep	88	78	79	87	393
Randfontein	45	80	84	92	185
Randburg	13	87	92	122	440
Germiston	143	93	89	116	297

The results of the multifactor analysis of variance are given in Table 2.

Table 2: Results of multifactor ANOVA

Source of variation	Sum of Squares	d.f.	Mean Square	F-ratio	Sig. Level
Main characteristics	1 758 425	11	159 846	4,405	,0000
Uranium deposits	603 667	2	301 833	8,318	,0003
Floor type	378 796	1	378 796	10,439	,0013
Sub-floor	330 050	3	110 017	3,032	,0284
Ventilation	446 524	5	89 305	2,461	,0314
2-factor interactions	1 508 942	30	50 298	1,386	,0809
Floor-type/uranium	435 650	2	217 825	6,003	,0025
Floor-type/subfloor	99 916	2	49 958	1,377	,2528
Floor-type/ventilation	239 179	5	47 836	1,318	,2536
Ventilation/uranium	420 480	10	42 048	1,159	,3147
Sub-floor/ventilation	234 736	9	26 082	,719	,6921
Sub-floor/uranium	5 472	3	1 824	,050	,9851

935 missing values have been excluded.

DISCUSSION

Measurements in about 2 000 residential homes in South Africa indicate an approximate log-normal distribution of indoor radon concentrations. An average concentration of about 63 Bq/m³ was measured during the winter months of three consecutive years. If corrected for seasonal variations an average closer to 42 Bq/m³ is expected.

Table 2 shows that geological type (containing uranium) and floor type played significant roles as well as the combination of these factors.

The results from Table 1 show that coal burning (Soweto) did not result in higher radon concentrations in the typical residences where coal is burnt.

Detailed discussions are given in a separate report (AEK-0036/90).

CONCLUSIONS

The average indoor radon concentration found in about 2 000 South African residences averaged about 63 Bq/m³. The seasonally-averaged value is estimated to be closer to 42 Bq/m³. Although the former value ranges high among international values, the percentage of houses with concentrations above 200 Bq/m³ coincide closer with the international average. In less than 1 % of the houses monitored, concentrations about 400 Bq/m³ were recorded while between 3 and 4 % recorded values above 200 Bq/m³. With the seasonal correction these percentages decrease to 0,5 % and between 1 and 2 % respectively.

REFERENCES

- Borak *et al* (1989). Borak, T B; Woodruff, B; Toohy, R E. A survey of winter, summer and annual average ²²²Rn concentrations in family dwellings. *Health Physics* V. 57, p. 465.
- Cohen *et al* (1986). Cohen, B L; Mason, R. A diffusion barrier charcoal adsorption collector for measuring Rn concentrations in indoor air. *Health Physics* V. 50, p. 457.
- Urban *et al* (1981). Urban, M; Piesch, E. Low Level environmental radon dosimetry with passive track-etch detector device. *Rad. Prot. Dosim.* V. 87, p. 109.
- AEK-0036/90. Assessment of the Extent and Influence of indoor Radon Exposures in South Africa. Nov 1991.

RADIATION EXPOSURE BY MAN-MODIFIED MATERIALS CONTAINING NATURAL RADIONUCLIDS

* D. E. Becker, ** E. Eder, * A. Reichelt

- * Technical Inspection Agency of Bavaria, Munich, Germany
** Government of Bavaria, Ministry for State Development and
Environmental Affairs Development, Munich, Germany

ABSTRACT

More than one hundred materials, containing natural radioactive nuclides, are being investigated due to radiation exposure to people. This paper deals with thoriated gas mantles and shows that the radiation exposure by inhalation of radionuclides released while burning and exchange is not negligible.

INTRODUCTION

As a consequence of the restrictive limitation of radiation exposure in the Federal Republic of Germany, caused by artificial radionuclides, the radiation exposure by natural nuclides has become more importance. By human work some natural materials are changed in such a way, that natural radionuclides are enriched. Therefore remarkable exposures are possible in some cases. These exposures are especially relevant, when radioactive aerosols are generated, which result in radiation exposure by inhalation.

Within a research programme of the Bavarian government, more than 100 man-modified materials (raw materials, residual materials and consumer products) were found with a relevant amount of natural radionuclides.

Objective of our research was to examine the radiation exposure of workmen and other people handling with such materials. By means of a literature study and own calculations we found relevant subjects for further investigations. The most interesting sources we have identified are:

- thoriated gas mantles
- thoriated tungsten welding rods
- dental products containing uranium
- phosphate fertilizers
- zircon sand
- radon therapy
- mines and caves for visitors
- water purification plants

In the following we will present a special part of our investigation, dealing with the "thoriated gas mantles".

NUCLIDES AND ACTIVITIES OF GAS MANTLES

The gas mantles used for gastechnical illumination are impregnated with natural thorium to produce incandescence. Thorium is extracted from ores by separation. In practise only Th-232 with daughters and Th-230 is relevant for radiation exposure.

We determined the activity of 39 gas mantles bought in normal storehouses. The time since thorium was separated from the ore was mathematically evaluated from activity values. Here some results in extracts.

Measurement results of specific activity in several samples of gas mantle										
Number of sample	specific activity a of a mantle [Bq/g] and relative error δa [%] ¹									
	a(Th-232)	δa	a(Ra-228) a(Ac-228)	δa	a(Th-228) a(Ra-224) a(Rn-220) a(Po-216) a(Pb-212) a(Bi-212)	δa	a(Tl-208)	δa	a(Po-212)	δa
1	387	9,0	97	8,3	196	8,9	71	8,9	125	8,9
2	746	6,3	125	5,9	460	6,2	166	6,2	293	6,2
4	682	26,0	407	2,3	336	3,1	122	3,1	215	3,1
9	582	6,2	135	5,9	307	5,9	111	5,9	196	5,9
10	809	10,6	101	10,4	560	10,5	203	10,5	357	10,5
15	642	11,2	133	10,9	358	11,0	130	11,0	229	11,0
16	829	11,4	153	10,7	490	11,4	177	11,4	312	11,4
18	1041	6,4	312	5,3	484	6,2	175	6,2	309	6,2
23	10	36,1	6	7,0	5	4,6	2	4,6	J	4,6
37	0,4	59,7	0,1	140	0,2	21,2	0,1	21,2	0,1	21,2
38	2866	9,1	806	9,1	1373	9,0	497	9,0	876	9,0
39	2701	10,0	1417	10,0	1210	10,0	438	10,0	772	10,0

¹ - Considered is the activity of Th-232 and Th-232 daughters

Results of the determination and calculation of quantities of several samples of gas mantles								
Number	Total activity A [Bq]	δA [%]	specific total activity a [Bq/g]	δa [%]	mass m [g]	δm [%]	Th-separation time t [a]	δt [%]
1	7810	4,0	1953	4,7	4,0	2,5	2,4	8,4
2	8004	2,5	4212	5,8	1,9	5,3	1,5	4,8
4	6157	2,3	3848	6,7	1,6	6,3	7,5	12,7
9	5999	2,4	2999	5,5	2,0	5,0	2,2	5,5
10	5919	2,6	4932	8,7	1,2	8,3	1,1	5,0
15	3416	3,5	3416	10,6	1,0	10,0	1,9	7,7
16	4561	4,3	4561	10,9	1,0	10,0	1,7	7,4
18	17177	3,9	5052	4,9	3,4	2,9	3,0	8,6
23	61	4,0	55	9,9	1,1	9,1	7,3	24,8
37	2	20,9	2	22,5	1,2	8,3	1,8	169,8
38	5634	0,5	14086	25,0	0,4	25,0	2,7	2,4
39	7003	0,4	14005	20,0	0,5	20,0	6,2	2,7

In a number of samples also the Th-230 activity was determined. The average specific activity was 207 Bq/g and the average Th-232/Th-230 ratio was found to 0,3.

RADIOACTIVITY EMITTED FROM BURNING GAS MANTLES

During the initial burn and during burning, a part of radioactivity is released from the gas mantle. The results of a study are shown in the following figures. They represent the relation of the specific activity of the burning mantle to the unused mantle as a function of burning time.

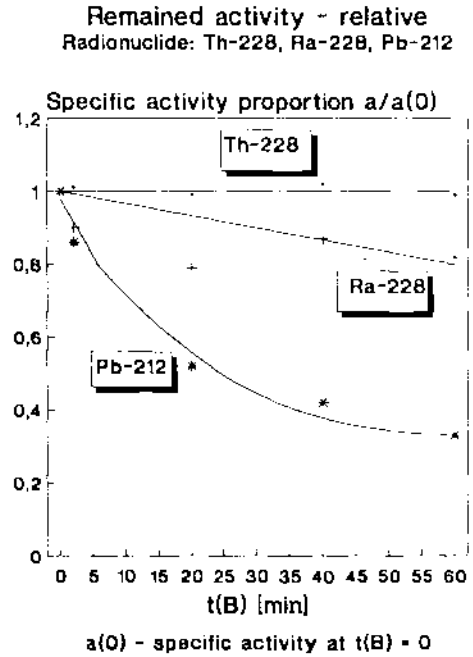
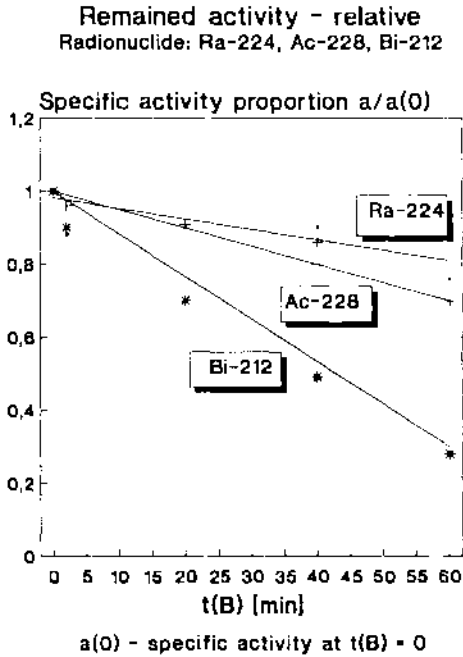

From these results, it is possible to assess the radiation exposures by inhalation of nuclides released from burning mantles. For example we will give a conservative assessment.

Assumptions for the calculation: room closed, no ventilation rate, breath rate: $1,2 \text{ m}^3/\text{h}$, dose conversion factor (ICRP 30) for AMAD = $0,1 \mu\text{m}$, highest retention class, time of exposure: 1 h, number of burning mantles: 1, activity of unused mantle: values of sample number 18, no attachment of radionuclides on objects, volume of space:

- a) 2 m^3
- b) 10 m^3
- c) 50 m^3

Effective committed dose equivalent H_{50} :

- a, $H_{50} = 0,43 \text{ mSv}$
- b, $H_{50} = 0,13 \text{ mSv}$
- c, $H_{50} = 0,03 \text{ mSv}$

INHALATION OF RADIONUCLIDES BY THE EXCHANGE OF GAS MANTLES

After the initial burn, gas mantles are very unstable against mechanical influence. For that reason, mantles have to be exchanged from time to time. Because the material is very brittle radioactive aerosols are generated and inhaled by the handling people.

We investigated the above mentioned problem with a cascade impactor. All conditions of the experiments were in that manner, that the human respiration was simulated by the measuring equipment. The following figures are showing results for Th-232.

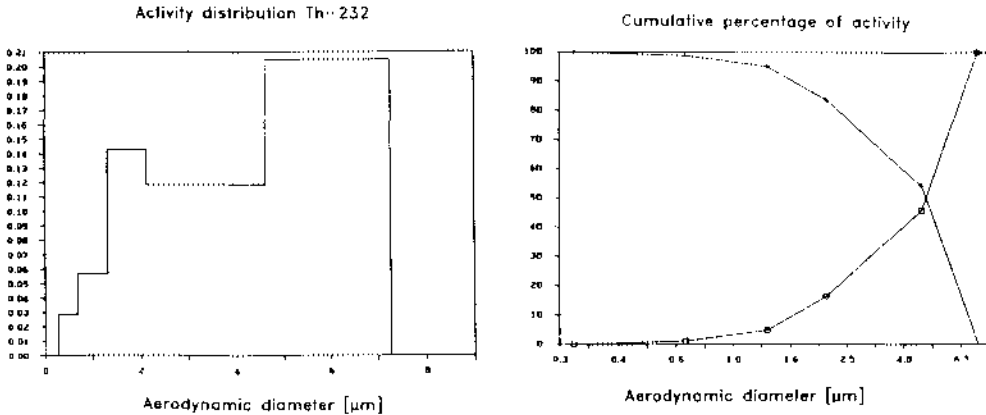

The effective committed dose equivalent H_{50} was calculated with three methods:

- first assessment: no consideration of the activity size distribution, Dose Conversion Factor (ICRP 30) for AMAD = 1 μm , the same activity for each nuclide (on an average)
- second assessment: like a₁, but with consideration of the different activities of the nuclides
- third assessment: consideration of the activity size distribution.

Effective committed dose equivalent H_{50} for one exchange, lasting four minutes:

- a, $H_{50} = 0,33 \text{ mSv}$ b, $H_{50} = 0,48 \text{ mSv}$ c, $H_{50} = 0,27 \text{ mSv}$

FINAL REMARKS

Although the use of gas mantles in the public illumination for streets and squares is decreasing, there is a high increase for camping lanterns, so that radiation exposure by inhalation of radioactive nuclides is not negligible.

INDOOR RADON CONCENTRATION IN A TEST CHAMBER: EXPERIMENTAL DATA AND THEORETICAL EVALUATIONS

D. Capra*, C. Silibello*, G. Queirazza'

* Cise SpA - Via Reggio Emilia, 39 - 20090 Segrate (MI)
+ ENEL/CRTN - Via Rubattino, 54 - 20134 Milano

ABSTRACT

This paper reviews the preliminary work performed to evaluate the influence of building materials on Radon concentration. Experiments were carried out under various conditions in order to examine data variability in a test chamber built in Milan. A mathematical model, based on the Jacobi-Pörstendorfer theory, was developed to predict Radon and daughters concentrations in the chamber. The model yields Radon concentration estimates that agree with experimental data and permits Radon progeny concentrations and doses in the chamber to be evaluated.

INTRODUCTION

The Italian National Electricity Board (ENEL) has set up, in cooperation with CISE, an investigation program for the purpose of assessing the hazards connected with coal ashes being used as partial substitutes for cement and other building materials in civil applications. This program refers specifically to Radon emanation characteristics, since Radon is the major natural radiological hazard for the community. Preliminary laboratory tests on the exhalation rate of powdered samples had shown a slight contribution of fly ashes to indoor Radon concentrations⁽¹⁾. In order to confirm these evaluations, two identical rooms (3.4 x 3.8 x 2.15 m) were built using conventional and fly ash-containing building materials. The two rooms were separated from the ground by a 40 cm high crawl-space. A sandy underlying soil with a high porosity level and sidewise diffusion and a shallow foundation were used to obtain the lowest possible Radon concentration in the crawl-space in order to enhance the Radon emanation of the rooms' building materials.

The principal objectives of this work were to develop a mathematical model for estimating Radon levels in a test chamber, and to verify the accuracy of the model output by a comparison with experimental data.

METHODS

The study site was a test chamber, located near Milan, made of conventional building materials. Facilities were provided to produce any desired temperature, humidity and air-change conditions within the room. The following parameters were continuously monitored: Radon concentration inside the room, in the open air and in the crawl space; meteorological parameters (outdoor and indoor temperatures, differential atmospheric pressure, humidity). The air change rate was controlled by an SF₆ measurement system (see Appendix).

Experimental conditions were continuously changed, during the period November 1990 - August 1991, to evaluate the influence of various parameters (air-conditioning system, ventilation, humidity, differential pressure, differential temperature, Radon levels in the crawl space) on indoor Radon concentration. Mean values for all parameters are given in Table 1.

In order to evaluate the indoor Radon concentration which is not related to that outside by ventilation, hourly Radon entry rates were determined by using a general mass balance equation:

$$\frac{dC^{INDOOR}}{dt} = E_s \frac{S}{V} + \lambda_v C^{OUTDOOR} - (\lambda_v + \lambda_{Rn}) C^{INDOOR} \quad (1)$$

where C^{INDOOR} = indoor Radon concentration [$Bq\ m^{-3}$], $C^{OUTDOOR}$ = outdoor Radon concentration [$Bq\ m^{-3}$], E_s = Radon exhalation rate from walls [$Bq\ m^{-2}\ h^{-1}$], S = room surface area [m^2], V = room volume [m^3], λ_v = ventilation rate [h^{-1}], λ_{Rn} = Radon decay constant [h^{-1}]. Assuming $\beta = E_s S / V + \lambda_v C^{OUTDOOR}$ and $\alpha = \lambda_v + \lambda_{Rn}$, the general solution of this equation, over a particular time step $\Delta t = t - t_0$, is:

$$C^{INDOOR}(t) = \frac{\beta}{\alpha} [1 - \exp(-\alpha \Delta t)] + C^{INDOOR}(t_0) \exp(-\alpha \Delta t) \quad (2)$$

Using measurement data to supply hourly values of indoor Radon concentration and air change rates, Effective Radon Entry Rates (ERER = [$Bq\ m^{-3}\ h^{-1}$]) were calculated for each hour of the period using the following relation⁽²⁾:

$$ERER(t) = \alpha \left[\frac{C^{INDOOR}_{measured}(t) - (C^{INDOOR}_{measured}(t_0) \exp(-\alpha \Delta t))}{1 - \exp(-\alpha \Delta t)} \right] - \beta \quad (3)$$

Seasonal averages of the measured and calculated parameters are shown in Table 2 (the ventilation rate is derived using mass balance formula in Appendix and ERER is calculated considering that Radon exhalation rate from walls is quite constant with an average value of about $2\ Bq\ m^{-2}\ h^{-1}$).

In order to predict Radon and daughters concentrations in the chamber, a general mass balance model was developed. This model, called RADBOX, represents a dynamic version of Jacobi-Pörstendorfer one and it is stated as a system of differential equations reflecting the mass balance among Radon (equation 1) and its progeny in the three forms: free, attached and deposited⁽³⁾⁽⁴⁾⁽⁵⁾.

Using available data for attachment, deposition and desorption rate constants, it is possible to estimate Radon and its progeny concentrations, equilibrium factor and Potential Alpha Energy Concentration (PAEC) inside the chamber.

RESULTS AND DISCUSSION

As shown in Table 1 and 2, measurements carried out inside the test chamber indicate the dependence of Radon concentration with ventilation and stack effect (variation of differential pressure with height across a vertical wall separating air masses of different temperatures). An increase in ventilation causes a diminution of the differential pressure ($P_{outdoor} - P_{indoor}$), due to the inlet of outdoor air. Both the lower Radon concentration in the outdoor air and the suppression of the upward airflow from the crawl-space (more contaminated) determine a lowering of indoor Radon concentrations (see Table 1 experimental conditions 2, 3 and 8). From Table 2, seasonal variations of indoor Radon concentrations and Radon entry rates (ERER) are related to stack effect action on upward airflow in the chamber. Higher Radon concentrations ($40-50\ Bq\ m^{-3}$) and higher entry rates ($5-7\ Bq\ m^{-3}\ h^{-1}$) in autumn and winter were consistent with lower differential

temperature ($T_{\text{outdoor}} - T_{\text{indoor}}$) and higher differential pressure (about to 1.8 Pa). During spring and summer both the differential temperature and differential pressure were mostly close to zero. This means that the stack effect was suppressed and Radon entry rates were low. The aspiration of air from the crawl space (see table 1 experimental condition 16) does not show a great influence on the indoor Radon levels because of the low residual Radon concentration in the crawl-space.

A comparison of model results with observations shows that hourly average predictions for indoor Radon concentrations ($>10 \text{ Bq m}^{-3}$) are within 14 % agreement of the corresponding experimental data. Calculated and observed hourly ^{222}Rn concentrations for two different ventilation conditions ($\lambda_v = 2.1$ and 0.69 h^{-1}) are compared in Figs 1 and 2 respectively. Calculated values for ^{222}Rn are in close agreement with observations, but a model-observation discrepancy occurs for low values ($3 \pm 10 \text{ Bq/m}^3$).

APPENDIX: TWO WAYS TO ESTIMATE VENTILATION IN THE TEST CHAMBER

Since ventilation measurements using SF_6 techniques are only possible in some representative situations, two different approaches are being used for continuous ventilation monitoring.

The first one estimates ventilation using a power law expression $\lambda_v = VD\Delta P^n$ where D =permeability of building envelope [$\text{h}^{-1} \text{ Pa}^{-n}$], ΔP = pressure drop across the building envelope [Pa] and n =flow exponent [dimensionless]. In this study we used $n=0.65^{(6)}$ and a value of $D=0.76 \text{ h}^{-1} \text{ Pa}^{-0.65}$, calculated according to previous formula, when both ventilation rate and pressure drop were available.

The second approach is derived from the mass balance equation (1) assuming steady state conditions and neglecting λ_{Rn} ; so that λ_v can be evaluated from measurements of Radon emanation and indoor and outdoor Radon concentrations using this formula:

$$\lambda_v = (E_0 S / V) / (C^{\text{INDOOR}} - C^{\text{OUTDOOR}})$$

Figure shows the comparison between measured (SF_6 technique) and calculated ventilation rates (Power law and mass balance formula)

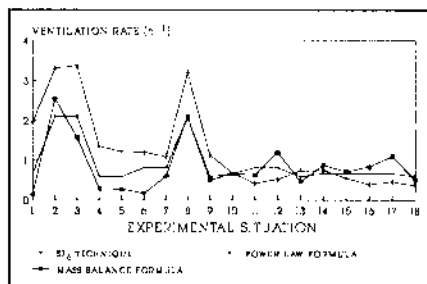

REFERENCES

1. A. Battaqlia, D. Capra, G. Queirazza and A. Sampaolo Radon exalation rate in building material and fly ashes in Italy. Proceedings of the 5th International Conference on Indoor Air Quality and Climate, Toronto (Canada) 29 July - 3 August 1990, Vol.3, pp. 47-52.
2. EPRI (1988) Measurements of Differential Pressures and Radon Entry in Research Houses and Evaluation of Radon control Methods. EPRI EM-6151.
3. W. Jacobi (1972), Health Physics 22:441-450.
4. J. Pörstendorfer (1984), Rad. Prot. Dosimetry 7:107-113.
5. E.O. Knutson, A.C. George, J.J. Frey and B.R. Koh, Health Physics 45:445-452.
6. M.H. Sherman (1980) Air infiltration in buildings. PhD Thesis, LBL-10172, University of California, Berkeley, CA.

Table 1: Experimental conditions inside the test chamber in the period: November 1990 - August 1991

Experiment condition	Inlet air from outdoor	Outlet air toward outdoor	Ventilator	Unit ¹⁾	Period	Radon concentrations			T _{out-Tin} [°C]	P _{out-Pin} [Pa]	Humidity [%]	Ventilation [h ⁻¹]
						indoor [Bq m ⁻³]	outdoor [Bq m ⁻³]	crawl space [Bq m ⁻³]				
1	OPEN	OPEN	OFF	ON	11/09-11/23	47.5	30.9	---	-13.5	1.8	43.6	0.7
2	OPEN	OPEN	ON	OFF	11/23-12/05	21.1	20.8	---	-15.7	-9.6	27.8	2.1
3	CLOSED	CLOSED	ON	OFF	12/05-01/07	29.9	27.4	191.8	-17.6	9.9	24.5	2.1
4	CLOSED	CLOSED	OFF	OFF	01/07-01/10	44.5	29.6	254.2	-15.7	1.9	33.6	0.6
5	CLOSED	CLOSED	OFF	ON	01/10-01/22	39.3	25.8	257.5	-15.4	2.1	47.9	0.6
6	CLOSED	OPEN	OFF	ON	01/22-01/31	57.1	56.7	120.0	13.5	10.0	54.2	0.8
7	OPEN	CLOSED	OFF	ON	01/31-02/07	32.2	21.5	253.9	14.2	1.8	49.5	0.8
8	OPEN	CLOSED	ON	OFF	02/07-03/12	24.5	24.9	153.3	-17.1	-9.2	36.0	2.1
9	CLOSED	CLOSED	ON	OFF	03/12-03/14	29.0	20.6	231.6	-8.2	0.8	62.5	0.6
10	OPEN	OPEN	ON	OFF	03/14-03/22	30.4	24.9	266.8	-5.8	0.9	59.7	0.7
11	CLOSED	OPEN	ON	OFF	03/22-03/25	22.3	17.3	297.9	-7.6	0.1	71.6	0.8
12	OPEN	CLOSED	OFF	OFF	03/25-04/09	20.3	16.5	181.1	-5.4	0.2	58.6	0.8
13	CLOSED	CLOSED	OFF	OFF	04/09-05/03	24.4	15.9	215.2	-5.9	0.1	55.4	0.6
14	OPEN	OPEN	OFF	OFF	05/03-06/14	18.0	13.6	190.8	-3.0	0.5	48.3	0.7
15	OPEN	OPEN	OFF	OFF	06/14-08/05	21.3	17.1	181.8	5.0	0.2	51.2	0.7
16	OPEN	OPEN	OFF	OFF	08/05-08/08	29.0	24.1	43.9	6.2	0.1	48.2	0.7
17	OPEN	OPEN	OFF	OFF	08/08-08/19	22.8	19.2	204.4	6.3	0.2	51.9	0.7
18	CLOSED	CLOSED	OFF	OFF	08/19-08/22	26.2	19.7	273.1	5.3	0.3	57.7	0.6

¹⁾ = Conditioning system set in refreshing air position
²⁾ = Air exfiltration from crawl-space

Table 2: Seasonal variation of measured and calculated parameters inside the test chamber with air change rate in the range 0.6-0.8 h⁻¹

Season	Radon concentrations			T _{out-Tin} [°C]	P _{out-Pin} [Pa]	ERER [Bq m ⁻³ h ⁻¹]	Ventilation* [h ⁻¹]
	indoor [Bq m ⁻³]	outdoor [Bq m ⁻³]	crawl space [Bq m ⁻³]				
Autumn ('90)	47.5	30.9	---	-13.5	1.8	5.6	0.1
Winter (90/91)	40.5	27.2	226.2	-13.0	1.8	7.7	0.4
Spring ('91)	20.4	15.0	196.8	-3.9	0.3	2.0	0.8
Summer ('91)	23.2	18.6	189.1	5.6	0.1	1.3	0.8

* = Ventilation calculated using reduced mass balance formula in Appendix

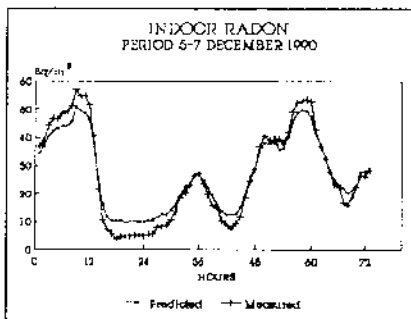

Figure 1: Application of RADBOX model to the test chamber (ventilation = 2.1 ACH)

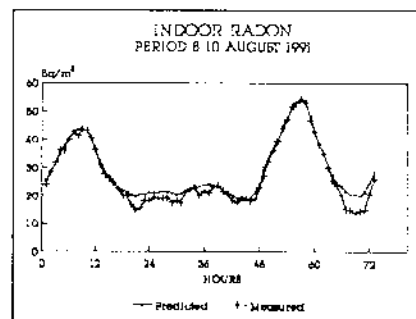

Figure 2: Application of RADBOX model to the test chamber (ventilation = 0.67 ACH)

RECONNAISSANCE TECHNIQUE FOR RADON RISK
CLASSIFICATION OF FOUNDATION SOILS

Martin Neznal, Matěj Neznal, J. Šmarda

RADON corp.
Za koncem 1380, 28922 Lysá nad Labem
CZECHOSLOVAKIA

ABSTRACT

Infiltration of radon from the ground is usually the primary source of indoor radon pollution. A uniform method for radon risk classification of foundation soils based on soil-gas radon concentration measurements and on the determination of soil porosity, permeability and structure was proposed in 1990. Results of assessment of some areas in Czechoslovakia, containing more than 5 000 radon concentration measurements, demonstrate the utility of the technique and confirm the link between geology and radon potential of the soil.

INTRODUCTION

The Czech Republic /CR/, the western part of Czechoslovakia, is situated mostly on the eastern end of the Central European Platform with a higher than normal content of uranium in rocks. These geological conditions cause higher risk of radon penetration into buildings from the ground. Since the acceptance of the Decree of the Ministry of Health of the CR concerning the Requirements for Limiting the Irradiation from Radon and Other Natural Radionuclides /1/ in 1991, the detailed radon measurements are obligatory for all areas of urban planning.

RADON corporation, a private radon monitoring firm, was established in 1990. During one year it has realised a radon survey at about 70 areas of different size /from 400 to 200 000 sq.m./, especially in Prague and in Northern Bohemia but also in other regions of the CR. Some results of this work, containing more than 5 000 radon concentration measurements, are presented in this paper.

RADON RISK CLASSIFICATION OF FOUNDATION SOILS

The uniform method for radon risk classification of foundation soils, proposed by Geological Survey Prague in cooperation with the Ministry of Health of the CR and other authorities /2/, is based on soil-gas radon concentration measurements at each measured point of the area investigated /grid 10 x 10 m/ and on permeability classification of foundation soils, which respect the Czechoslovak National Standard 731001 /three groups of foundation soils - low, medium and high permeability soil classes - see Table 1/. The other parameters including vertical and horizontal changes in soil

and rock profile are also taken into consideration /geological description and laboratory analysis - the documentation of 4 - 6 drillings for each 10 000 sq. m. of the area/. In practice, the radon classification is usually done in connection with the engineering geological investigation.

Table 1 - Radon risk classification of foundation soils

classification of risk /categories/	radon concentration /222-Rn/ in the soil gas /kBq.m-3/		
	low	medium soil permeability	high
low risk area	< 30	< 20	< 10
medium risk area	30 - 100	20 - 70	10 - 30
high risk area	> 100	> 70	> 30

Note : A special category of extremely high risk has been established for anomalies more than ten times higher than those at the high risk areas.

SOIL-GAS RADON CONCENTRATION MEASUREMENTS

The soil-gas sample collection method has been described recently /3/, similar sampling technique was used by Reimer /4/. The sampling system consists of a small-diameter hollow probe pounded into the ground to a depth of 0,60 - 0,80 m. Samples of about 100 cm³ are collected by a syringe and introduced into evacuated Lucas cells. The cells are transported into the laboratory and counting begins usually from 5 to 15 hours after injection. The radon concentration is determined with analytical sensitivity of about 0,3 kBq.m⁻³.

Both the method and its calibration have been verified in the Reference laboratory /Ministry of Health of the CR/. In September 1991 RADON corporation took part in the international intercomparison and intercalibration exercise /Badgastein, Austria/.

SURVEY RESULTS

It is known, that soil characteristics do vary over a small area, both large scale and the small scale parameters have to be considered. The first effort is to gather general data appropriate for radon assessment on the large scale - lithology, soil and bedrock structure, structural geo - mechanical deformation of rocks. The second approach is to investigate factors influencing the production and migration of radon in soils. In brief, it is necessary to determine local soil conditions - in particular the permeability and changes in the soil profile.

Experiences based on the large number of survey data are shown in the following summary.

1. It is possible to collect a large number of samples in a short time period. Sample collection must be made very carefully. Perfect sealing of all parts of the equipment is especially important. There are no problems with sample collection even when very high soil-moisture contents or fine clays are encountered. Some difficulties may appear when the sampling depth is below the ground water level.

2. Tectonic zones determine the potential for more serious radon problems to exist. Measurements in some regions in the north-western part of Bohemia confirmed this fact. Values of soil-gas radon concentration observed in the area situated on a tectonic zone /Hrob area/, where longitudinal and transverse faults form a fault belt /called Krušnohorský/, were about four times higher than those in the near-by areas with similar geological conditions /Litvínov and Dubí areas/. Average soil-gas radon concentration in the Hrob area was 300 kBq . m⁻³ /standard deviation 261 kBq . m⁻³; number of samples 36/, while in the Litvínov area it was 69,7 kBq . m⁻³ /27,8 kBq . m⁻³; 36/ and in the Dubí area 84,9 kBq . m⁻³ /34,1 kBq . m⁻³; 36/. Similar results were obtained in Chaby, Prague, where RADON corporation had realised a detailed radon survey for the projected housing estate /3/ - about 1 700 soil-gas radon concentration measurements.

3. Radon risk mapping on large scales is first of all based on the evaluation of bedrock. In many measured areas, soil-gas radon concentrations really correspond to the expected radon potential of bedrock with different stratigraphical and petrographical character /3/. On the other hand, some results of detailed in situ measurements / for example at the locality north of Prague/ illustrate the significant role of various soil layers. Two reference areas /Veltěž, Ďáblice/ are situated in the Tertiary /Pliocene/ sandy gravel fluvial and lacustrine sediments. Owing to the granite pebble content in these sediments, higher radon concentrations were assumed. In the Ďáblice area, loess eolian deposits /average thickness of about 5 m/ cover underlying fluvial and lacustrine sediments. Homogenous and relatively less permeable loess and loess loam cause homogenous and relatively not so high soil-gas radon concentrations ranging from 29,5 to 58,4 kBq . m⁻³ /average value 41,8 kBq . m⁻³; standard deviation 7,2 kBq . m⁻³; number of samples 36/. Different situation was found in the second area /Veltěž/, where the thickness of loess eolian deposits varies from 0 to 1m. Soil-gas samples were thus collected in the layer of high permeable sandy gravel sediments. Presence of overlying less permeable layer at majority of the measuring points resulted in higher radon concentrations /with the highest value 158 kBq . m⁻³/and in inhomogenous distribution /average value 78,4 kBq . m⁻³; standard deviation 45,4 kBq . m⁻³; number of samples 36/. These results confirm the important role of air permeability of soils. The permeabilities have much larger range than the values for other parameters and local differences in them may be very significant in determining radon infiltration risk /5/.

4. Radon risk classification of foundation soils may be difficult in areas, where excavations or other human interventions occurred in the past, because of frequently observed anomalies.

5. Investigations concerning seasonal and meteorological variations of soil-gas radon concentrations have not been finished yet. Because it is evident that these variations differ in different geological conditions, further data are needed.

CONCLUSIONS

The applications presented in this paper demonstrate how geology /including lithology, structure and soil permeability/ and soil-gas radon measurements can be combined in a reconnaissance of the radon infiltration risk from the ground. Survey results improve understanding of factors controlling the radon generation and migration pathways. It is possible to divide the areas reserved for building activities into different groups of potential risk. When the locations of building areas or separate houses are known, the radon risk prevention technology for buildings can be chosen and proposed.

REFERENCES

- /1/ Decree of the Ministry of Health of the CR concerning the Requirements for Limiting the Irradiation from Radon and Other Natural Radionuclides /in Czech/, Coll. Laws, No.76,1991
- /2/ Barnet,I., Matolín,M., Veselý,V., Kulajta,V., A Proposal of the Radon Risk Classification of Foundation Soils, Radon Investigations in Czechoslovakia, Geological Survey Prague,p.24 - 28, 1990
- /3/ Neznal,M.,Neznal,M., Šmarda,J., Radon Infiltration Risk from the Ground in Chaby, Prague, Radon Investigations in Czechoslovakia II, Geological Survey, Prague, p. 34 - 39, 1991
- /4/ Reimer,G.M., Reconnaissance Technique for Determining Soil-gas Radon Concentrations, An Example from Prince Georges County, Maryland, Geophysical Research Letters, 17, p. 809 - 812, 1990
- /5/ Sextro,R.G., Moed,B.A., Nazaroff,W.W., Revzan,K.I., Nero,A.V., Investigations of Soil as a Source of Indoor Radon, ACS SYM Series 331, p. 10 - 29, 1987

**LE RADON DANS LES HABITATIONS
IDENTIFICATION DES SOURCES ET DES VOIES DE TRANSFERT**

M.C. Robé*, A. Rannou*, J. Le Bronec* et G. Tymen**

* CEA/Institut de Protection et de Sécurité Nucléaire
Département de Protection de l'Environnement et des Installations
CE/Saclay, 91191 GIF-SUR-YVETTE CEDEX, France

** Laboratoire de Physique des Aérosols et de Radioactivité Atmosphérique,
Faculté des Sciences, 6 avenue Victor Le Gorgeu, 29287 BREST CEDEX, France

RADON IN HOUSES - IDENTIFICATION OF SOURCES AND PATHWAYS OF TRANSFER

The Institut de Protection et de Sécurité Nucléaire (IPSN) is studying the remedial actions to reduce high concentration of radon in houses. The first step to know how to modify houses is to identify radon sources and pathways of transfer to upper floors.

A pilot study in Brittany was designed to develop a simple method of diagnosis. This investigation was based on indoor and outdoor measurements of ^{222}Rn activity concentration in the air and ^{222}Rn area exhalation rate from the soils and walls, measurements of the potential alpha energy concentration of ^{222}Rn daughters and the ventilation rate.

The structural characteristics of houses and the influence of the life style of the inhabitants were examined. Analysis of the results showed that a limited number of parameters can be selected for use in a rapid radon diagnosis.

INTRODUCTION

Dans le cadre du programme national d'évaluation de l'exposition du public aux rayonnements naturels à l'intérieur des locaux d'habitations, un certain nombre de maisons étudiées s'est avéré présenter de fortes concentrations en radon, susceptibles d'entraîner une exposition significative pour les occupants.

En vue de proposer des solutions appropriées de réduction des concentrations en radon, l'objectif recherché dans cette étude consiste à élaborer une méthodologie rapide et simplifiée de diagnostic. Cette méthodologie est établie à partir d'une série d'études plus complètes portant sur cinq maisons de Bretagne choisies selon les critères suivants :

- une activité volumique en radon 222 supérieure à 400 Bq.m^3 (limite recommandée pour les habitations existantes par la Commission des Communautés Européennes),
- une concentration en énergie alpha potentielle volumique (EAPv) supérieure à 10^{-6} J.m^{-3} (*),

(*) à l'équilibre radioactif entre les descendants à vie courte et le radon,
 $10^{-6} \text{ J.m}^{-3} = 180 \text{ Bq.m}^{-3}$

- les caractéristiques architecturales du bâtiment,
- le volontariat des occupants.

Nous présentons l'étude complète, d'une durée de 48 heures, ayant porté sur l'une de ces cinq maisons.

CARACTÉRISTIQUE DU BATIMENT

L'analyse des caractéristiques du bâtiment conduit à l'établissement d'un plan schématique d'agencement (figure 1). Il s'agit d'une maison construite en 1962 en parpaings, revêtue extérieurement de granit, possédant une cave dont le plancher est constitué de terre battue.

On note au rez-de-chaussée la présence de deux pièces, situées au-dessus de la cave, et dont le plancher est constitué par du travertin. Ce plancher n'est traversé par aucune canalisation provenant du sous-sol. Par contre, il existe une porte de communication entre cave et rez-de-chaussée.

Cette maison est assez représentative de l'habitat individuel en Bretagne.

PARAMETRES MESURÉS ET RÉSULTATS

On a procédé à un ensemble de mesures à l'intérieur et à l'extérieur de la maison (tableau 1).

	PARAMETRES mesurés	Lieu de mesure
radon 222	concentration dans l'air ambiant	simultanément dans la cave (pièce A) et le rez-de-chaussée (pièces B et C)
	concentration dans les sols (profondeur à 0,30 m)	cave jardin
	taux d'émanation surfacique	cave : plancher et murs rez-de-chaussée : plancher, jardin, perron
descendants à vie courte du radon	concentration en énergie alpha potentielle	cave, rez-de-chaussée, étage
radium 226	activité massique	sol de la cave
irradiation externe	débit de flux gamma	matériau de construction cave et jardin
ventilation	taux de renouvellement de l'air	rez-de-chaussée
paramètre météorologique	pression, température, humidité, vitesse et direction du vent, pluviométrie	environnement

Tableau 1 - Ensemble des paramètres mesurés à l'intérieur de la maison

L'ensemble des résultats est donné sur la figure 1.

On note dans la cave des flux d'émanation radon très importants (environ 100 fois le flux moyen à la surface du globe), rarement observés même en terrain granitique. Ceci entraîne, dans ce local peu ventilé, des concentrations en radon et en descendants à vie courte également très élevées.

Les mesures de concentration radon après un confinement de quelques heures au rez-de-chaussée révèlent des niveaux de l'ordre de $10\ 000\ \text{Bq}/\text{m}^3$.

A partir de l'ensemble de ces mesures il apparaît que la source est constituée par le plancher en terre battue de la cave et secondairement par les murs de celle-ci.

Le transfert de radon entre le sous-sol et le rez-de-chaussée s'effectue principalement par la porte de séparation, et secondairement au travers du plancher et dans les murs.

Ce diagnostic est confirmé par des mesures intégrées de l'énergie alpha potentielle volumique des descendants du radon sur une période de 15 jours. Elles mettent en évidence des niveaux de $25\ \mu\text{J}\cdot\text{m}^{-3}$ ($4500\ \text{Bq}\cdot\text{m}^{-3}$ de concentration équivalente radon à l'équilibre) dans la cave, entre 4 et $5\ \mu\text{J}\cdot\text{m}^{-3}$ (720 et $900\ \text{Bq}\cdot\text{m}^{-3}$) au rez-de-chaussée et de l'ordre de 1 à $3\ \mu\text{J}\cdot\text{m}^{-3}$ au premier étage (180 à $540\ \text{Bq}\cdot\text{m}^{-3}$).

Durant l'étude, les mesures montrent que l'ouverture des portes et des fenêtres conduit en quelques minutes à une chute d'activité de $7\ 000\ \text{Bq}\cdot\text{m}^{-3}$ à $1\ 000\ \text{Bq}\cdot\text{m}^{-3}$ tandis que leur fermeture entraîne un retour au niveau initial en l'espace de quelques heures.

CONCLUSION

Au cours de cette étude, comme dans les quatre autres maisons, les moyens mis en oeuvre étaient importants et parfois même redondants. Il faut noter une bonne cohérence entre les résultats des différents paramètres mesurés.

Ceci nous permet de proposer l'établissement d'un diagnostic rapide, avec des moyens réduits, en préconisant tout d'abord la localisation de la (ou les) pièce(s) où est (sont) située(s) la (ou les) source(s) de radon par :

- un examen visuel du soubassement et des matériaux de construction,
- des mesures instantanées et ponctuelles de la concentration du radon ou de ses descendants après une période de confinement de quelques heures.

Dans le cas d'une maison à plusieurs niveaux où des voies de transfert doivent être recherchées, des mesures instantanées de la concentration du radon ou de ses descendants doivent être effectuées aux différents niveaux après une période de confinement de quelques heures.

Si elle s'avère indispensable, l'identification plus précise de la source passe par des mesures de flux d'émission. Cette étape peut être facilitée dans certains cas par l'utilisation d'un scintillomètre portatif de prospection donnant des indications sur le débit de flux gsmma.

L'ensemble de ces étapes successives doit conduire, en moins d'une journée, à un diagnostic radon avec des moyens réduits.

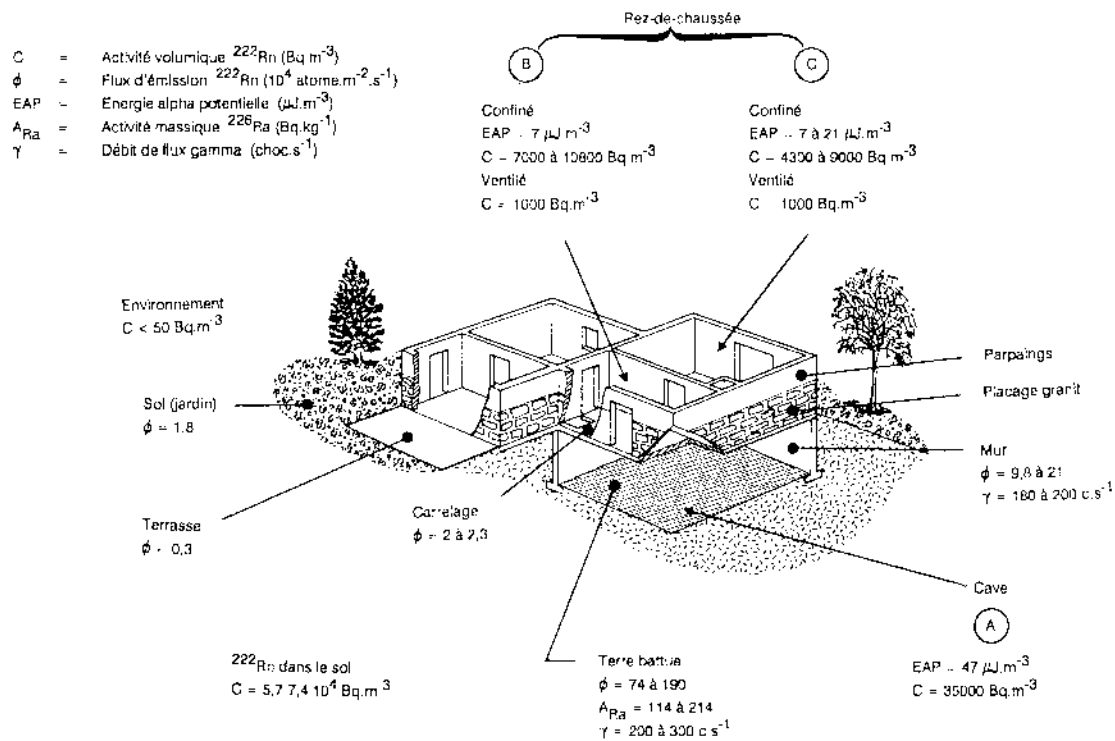

Figure 1 - Exemple de diagnostic radon dans une habitation : plan d'agencement, paramètres mesurés et résultats des mesures

METHODOLOGIE D'EXPERTISE DE L'IMPACT RADIOLOGIQUE
D'UN SITE DE DEPOT DE PRODUITS RADIFERES

M.C. Robé, A. Rannou, V. Labed, J. Le Bronec
CEA/Institut de Protection et de Sûreté Nucléaire
Département de Protection de l'Environnement
et des Installations
CE/Saclay - 91191 GIF-SUR-YVETTE CEDEX, France

THE RADIOLOGICAL IMPACT OF A RADIUM RICH
BY-PRODUCTS DEPOSIT : METHODOLOGY OF ASSESSMENT

Radiological impact due to the deposit of radium rich by-products can be assessed by:

- the characterization of the source-term based on the measurement of ^{226}Ra content and ^{226}Ra activity concentration in soil, area exhalation rate of ^{222}Rn from the deposit and external dose rate in air,
- the measurement of the activity concentration of ^{222}Rn in air above the ground,
- the study of the transfer of ^{222}Rn in the neighbourhood of the deposit with the same measurements as above.

The assessment can be followed by the radiological monitoring of the environment over more or less long periods of time consisting of the potential α energy at several stations, according to the protocole designed on the former results.

INTRODUCTION

L'exploitation de certains minerais, pour la production de matières premières comme l'uranium, les terres rares ou encore les phosphates, aboutit en fin de traitement à l'obtention, en grandes quantités, de matériaux de faible activité massique et de longue période. Ces matériaux sont désignés généralement par le terme de résidus. Parmi les radioéléments contenus dans ceux-ci se trouve généralement du radium 226.

La radioactivité de ces matériaux est, bien entendu, d'origine naturelle mais elle nécessite de prendre des dispositions afin de ne pas accroître de façon significative les risques pour les populations présentes et futures. Différentes possibilités existent pour les gérer soit sur le lieu d'extraction ou le lieu de traitement des minerais, soit sur un centre de stockage.

Il s'agit dans les deux premiers cas de dépôts de produits radifères de plus ou moins grandes étendues, pouvant être situés à des distances plus ou moins grandes de zones d'habitations.

Nous développons ci-après une méthodologie d'évaluation de l'impact radiologique de tels sites vis-à-vis du radon issu des produits radifères.

METHODOLOGIE D'EVALUATION

L'évaluation a pour but dans un premier temps de caractériser le site et son environnement plus éloigné ("bruit de fond régional") puis de définir un protocole de surveillance radiologique à plus ou moins long terme.

Cette évaluation, basée sur un ensemble de mesures, est réalisée en quelques jours.

La caractérisation du site et de son environnement se déroule principalement en 3 phases :

- caractérisation du terme source,
- étude du transfert dans l'environnement,
- mesure du bruit de fond régional.

La caractérisation du terme source (phase 1) comprend essentiellement des mesures ponctuelles de flux d'émission de ^{222}Rn à la surface du sol.

Les mesures sont effectuées selon une technique d'accumulation. Celle-ci consiste à déterminer, à un instant donné, l'activité volumique du radon collecté dans un conteneur, dont une face ouverte est appliquée sur le sol. La manipulation du dispositif nécessite une surface de sol débroussaillée d'au moins un mètre carré.

Pour la détermination de l'activité volumique du radon, deux prélèvements d'air sont effectués dans des fioles scintillantes mises préalablement sous vide.

Pour chaque point de mesure de flux, une fois les deux prélèvements d'air par fioles scintillantes réalisés, un échantillon de matériau superficiel est prélevé sous le conteneur, afin de déterminer l'humidité pondérale du sol au moment de l'analyse. En effet, les flux d'émission radon varient en fonction de l'humidité du sol. C'est pour cette raison que la mesure du flux ne peut pas avoir lieu par temps de pluie ou de neige.

De plus, en chaque point de mesure de flux radon, le débit de flux gamma est relevé au moyen d'un scintillomètre portatif.

Le nombre de points de mesure est choisi en fonction de la superficie du dépôt, sachant que l'investigation est poursuivie si nécessaire au vu des résultats.

Cette caractérisation du terme-source peut être complétée par des mesures instantanées d'activité volumique de ^{222}Rn dans le sol et des analyses en ^{226}Ra d'échantillons de matériaux.

L'étude du transfert du ^{222}Rn dans l'environnement (phase 2) se fait, parallèlement, au moyen d'un laboratoire mobile. Il est équipé :

- d'un système de génération électrique fournissant une autonomie de mesure de 24 heures,
- d'un système de repérage cartographique,
- d'un ensemble d'acquisition et traitement de données,
- de chambres d'ionisation permettant la mesure en continu du débit de dose gamma, à 2 m du sol environ, et de l'activité volumique radon 222. Le prélèvement d'air nécessaire se fait à une hauteur de 1,50 m du sol environ.

Afin de mettre en évidence les variations temporelles et spatiales les mesures ont lieu :

- à poste fixe, en quelques points du site, pendant des périodes de quelques heures à quelques jours, sous différentes conditions de diffusion atmosphérique (variations temporelles liées par exemple aux inversions de température pendant la nuit),
- en déplacement, selon des trajectoires fonction des caractéristiques du site (infrastructure routière, groupe d'habitations, orographie, ...) et des conditions météorologiques sous différentes conditions de diffusion atmosphérique.

Cette méthodologie est également appliquée dans l'environnement proche du dépôt. Quelques mesures de flux d'émission ^{222}Rn sont faites, le cas échéant, afin de déterminer si le ^{222}Rn observé dans l'atmosphère a une origine locale ou s'il est dû à un transfert à partir du dépôt des produits radifères.

Enfin dans un environnement plus éloigné du site de dépôt (à quelques kilomètres, hors d'influence du dépôt mais sur un terrain de caractéristiques géologiques comparables) on applique cette même méthodologie, afin de connaître les gammes de niveaux naturels de flux d'émission ^{222}Rn et d'activités volumiques dans la région (phase 3).

Les limites de la zone d'influence du dépôt peuvent être ainsi évaluées par rapport à ces niveaux de référence.

SURVEILLANCE RADIOLOGIQUE A PLUS OU MOINS LONG TERME

A partir de cette évaluation, une surveillance radiologique peut être exercée rationnellement pour évaluer l'éventuel supplément d'exposition pour des personnes résidant ou travaillant dans cette zone d'influence ("groupe critique"). Elle consiste en des mesures mensuelles de l'Energie Alpha Potentielle volumique (EAP_v) des descendants à vie courte du radon, représentatives du "groupe critique" et du niveau naturel. Cette surveillance radiologique peut être effectuée sur plusieurs mois ou années. De plus, elle permet de vérifier régulièrement que cette situation n'évolue pas.

CONCLUSION

La méthodologie d'évaluation décrite apporte très rapidement des informations utiles sur différents plans, tant pour l'exploitant que pour les autorités compétentes et la population.

D'une part, elle permet de caractériser, du point de vue radiologique, le site de dépôt de produits radifères et de déterminer sa zone d'influence dans l'environnement, compte tenu du niveau du bruit de fond régional.

D'autre part, si des groupes critiques de la population sont identifiés, cette étude permet de proposer l'implantation rationnelle d'un réseau de surveillance à plus ou moins long terme.

Cette méthodologie d'évaluation peut être appliquée sur un site en cours d'exploitation ou en fin d'exploitation ainsi qu'après qu'il ait été reconstitué.

Elle constitue alors une base de données pour aider à la gestion du site de dépôt.

**THE NATURAL RADIOACTIVITY OF NONURANIFEROUS
MINES FROM ROMANIA**

G.N. Sandor, G. Dinca, T. Peic, S.D. Stoici

Research and Design Institute for Rare and Radioactive Metals, Research Laboratory
for Radiation Protection, Working Conditions and Ecology - Petru Groza town,
Romania

ABSTRACT

Between 1970 - 1980 were investigated 267 mining and exploration non-uranium units at 104 (39.0%) being exceeded the maximum permissible radon concentration (MPC) for public (110 Bq/m^3) and at 15 (5.6%) the MPC for occupational exposure (1100 Bq/m^3), so being necessary the recommendation of limiting measures.

Were clarified the causes of appearance and accumulation of radioactive gases, the main source being the natural radioactive elements from rocks and minerals and the cause of accumulation the inefficiency of ventilation.

INTRODUCTION

In 1974 by a governmental programme, initiated by the Department of Mines and Geology, on the basis of measurements previously carried out by our laboratory², has been started the investigation of non-uranium mining and exploration units from the point of view of natural radioactivity.

The aim of this programme was to clarify the causes of appearance and accumulation of radioactive gases in the underground atmosphere and to estimate the workers' exposure.

The implied investigation methods have been those presented in Table 1.

TABLE 1. Investigation methods

Nature of samples Radioelement	Method	Sensitivity	
<u>Solid</u>			
U natural	Fluorimetry	0.05	g/t
Th natural	Spectrophotometry	0.2	g/t
Ra-226	Scintillation	$0.1 \cdot 10^{-6}$	g/t
<u>Water</u>			
U natural	Fluorimetry	$0.1 \cdot 10^{-6}$	g/t
Ra-226	Scintillation	0.004	Bq/L
Rn-222	Scintillation	0.4	Bq/L
<u>Air</u>			
Rn-222	Scintillation	200	Bq/m ³
Rn daughters	modified Kusnetz	40	Bq/m ³

To clarify the causes of appearance and accumulation were determined the concentrations of natural uranium and thorium and of Ra-226 in rocks, minerals and mine waters and those of Rn-222 in waters. The geological environment, the mining methods and the ventilating conditions were also investigated.

As thoron was found only in two mines, this paper will refer only to Rn-222.

The exposure to radiation was estimated by measuring the gamma dose rates and the concentrations of radon and its daughters.

EXPERIMENTAL RESULTS

Between 1970 and 1990 were investigated 267 underground non-uranium units. Were collected over 5,000 geological samples and were made determinations of gamma dose rate, radon and its daughters at over 7,000 underground sites.

In Table 2 are given some results of natural uranium and thorium content of geological samples analysed by our laboratory.³

TABLE 2. Uranium and thorium content of rocks (mean values)

Rock type	No. of samples	U	Th	Th:U
		g/t	g/t	
Igneous rocks	416	2.2	9.2	4.1
Metamorphic rocks	89	2.2	11.1	5.0
Sedimentary rocks	107	1.5	-	-

From the igneous rocks the highest radioactive element content is presented by the acid ones, from the metamorphic rocks by porphyrogenic schists and from sedimentary rocks by clays. The geological samples have an uranium and thorium content comparable to the mean content of upper lithosphere. The mean values for Ra-226 content vary from $1.4 \cdot 10^6$ g/t in acid igneous rocks to under $0.1 \cdot 10^8$ g/t in ultrabasic igneous ones.

The mean uranium and Ra-226 contents of mine waters are shown in Table 3.

TABLE 3. Uranium and radium 226 content of mine waters

Water source	No. of samples	U	Ra-226
		10^6 g/L	mBq/L
Infiltration waters	102	12.94	32
Drainage channel waters	233	13.10	58

The radon content of mine waters is frequently between 15 and 110 Bq/L and in some cases over 550 Bq/L.

The gamma dose rates varied between 0.02 μ Sv/h and 7 μ Sv/h, with mean values of 0.04 μ Sv/h in salt mines and 0.33 μ Sv/h in iron mines.

It can be said that the external radiation by gamma rays is not important for the exposure of workers from non-uranium mines.

The most important factor that contributes to the radiation exposure of workers in non-uranium mines is radon and its short-lived daughters. The results of determinations of equilibrium equivalent radon concentrations are given in Table 4.⁴

It can be seen from Table 4 that in 104 (39.0%) from the investigated units was exceeded the MPC for public and in 15 (5.6%) ones the MPC for occupational exposure.

The limiting measures concerned first of all the improvement of ventilation, primary and/or secondary, by increasing of air changes/min, distribution of air, maintenance of tubing and continuous operation of fans. The increasing of air

changes/min, can be obtained either by increasing of air flow rates or by reducing the volume of underground workings necessary to ventilate. For an underground working or a mine area it was used the following formula⁵:

$$Q = \left(\frac{C}{MPC} \right)^{0.55} \cdot Q_1 \quad (\text{m}^3/\text{min}) \quad (1)$$

where

- Q - required air flow rate (m³/min)
- Q₁ - provided air flow rate (m³/min)
- C - equilibrium equivalent concentration of radon in that environment (Bq/m³)
- MPC - 110 Bq/m³ - maximum permissible concentration for public.

For the general ventilation it was used the formula⁶:

$$Q = \frac{D}{MPC} = \frac{Q_1 \cdot C}{MPC} \quad (\text{m}^3/\text{min}) \quad (2)$$

where Q, Q₁, C and MPC have the meaning from (1) and D is the radon flow rate (Bq/m³). As it can be seen, relation (2) is more restrictive than relation (1), the resistance of the whole mine being higher than that of a working or a mine area. Both relations were used with success.

TABLE 4. Equilibrium equivalent concentration of radon vs. useful mineral
(mean values)

Mining and exploration units	No. of units	Equilibrium equivalent concentration Bq/m ³		
		<110	110-1100	>1100
Iron	26	13 (50.0%)	10 (38.5%)	3 (11.5%)
Non-ferrous	98	57 (58.2%)	34 (34.7%)	7 (7.1%)
Gold-silver	22	10 (45.5%)	12 (54.5%)	-
Bauxite	8	1 (12.5%)	7 (87.5%)	-
Pegmatite	9	5 (55.6%)	4 (44.4%)	-
Talc, clay, opalin or bentonite	15	10 (66.7%)	5 (33.3%)	-
Barytine	4	1 (25.0%)	1 (25.0%)	2 (50.0%)
Salt	8	8 (100.0%)	-	-
Coal	67	36 (53.7%)	28 (41.8%)	3 (4.5%)
Bituminous shale	6	3 (50.0%)	3 (50.0%)	-
Total	267	143 (53.5%)	104 (39.0%)	15 (5.6%)

An epidemiological study⁷ proved that, in a gold mine having a mean cumulative exposure to radon of over 60 WLM, the frequency of death by respiratory cancer, in the period 1960-1985, was 1.9 times greater for miners than for the public from the same region, supposing the same smoking habits.

CONCLUSIONS

Responsible for the appearance of radon 222 in the atmosphere of underground non-uranium mines is the presence of Ra-226 in rocks, minerals and mine waters.

There is no linear relationship between the level of the radon and the natural radioelement content of geological environment, respectively the gamma dose rate, but it strongly depends upon the ventilating conditions.

From the 267 investigated units in 113 (44.8%) ones was necessary the application of limiting measures, concerning first of all the improvement of ventilation.

Responsible for the cumulative exposure of non-uranium workers are radon and its daughters, the contribution of external dose by gamma radiation being insignificant.

REFERENCES

1. Republican standards for nuclear safety, SCNE, 1976 (in Romanian)
2. Dinca, G., Moldovan, M., Popescu, D., Significant exposures to radon 222 and thoron 220 in less known circumstances, VI Symp. on Radiation Hygiene, 28-29 sept., 1972, Iasi (in Romanian).
3. Stoici, S.D., Tataru, S., Uranium and Thorium, Technical Publishing House, Bucharest, 1988, pp. 36-64 (in Romanian).
4. Sandor, G.M., Stoici, S.D., Spataru, M., Paic, T., 112 unpublished reports upon the natural radioactivity of non-uranium mines from Romania, 1970-1990 (in Romanian)
5. Rock, R.L. and Walker, D.K., Controlling employee exposure to alpha radiation in underground uranium mines, Bureau of Mines, United States Department of Interior, 1970, vol. I.
6. STANDARD 11771/6-84, Natural radionuclides with pollution potential resulting from ores and coals (in Romanian).
7. Dinca, G., Popescu, G., Epidemiological study of deaths by pulmonary cancer in the period 1960-1985 of ex-miners from Barza Mining Co. (unpublished), 1986, (in Romanian).

ACKNOWLEDGEMENT

This paper is published by permission of the Department of Mines.

RADIOLOGICAL IMPLICATIONS OF NATURALLY OCCURRING
RADIOACTIVITY IN AN ELEMENTAL PHOSPHORUS REFINERY

Leo M. Lowe, D.B. Chambers
SENES Consultants Limited
52 West Beaver Creek Road
Richmond Hill, Ontario
Canada L4B 1L9

ABSTRACT

Phosphate ore mined in central Florida contains small amounts of naturally occurring uranium. This ore is the feed for a plant in Quebec that produces elemental phosphorus by the electrothermal method. Calcium silicate ("phosphate slag"), a by-product of the refining process, has excellent properties as an aggregate material. This paper reviews the radiation exposures of the plant workers and some potential uses of the by-product silicates.

INTRODUCTION

Phosphate ore can be refined to produce phosphoric acid or elemental phosphorus. Ore from the State of Florida in the United States contains up to 100 to 200 ppm of naturally occurring uranium, or up to 60 times the 3 ppm of uranium found in typical rocks and soils. In a Quebec plant, elemental phosphorus is produced by the electrothermal method whereby the ore, after first being calcined and formed into nodules, is fed to an electric furnace with silica and coke. The high temperature reaction produces gaseous elemental phosphorus which is collected and distilled. The reaction also produces a by-product calcium silicate (sometimes called "slag"), a hard ceramic-like material, which retains most of the uranium and associated decay products.

The silicates have excellent properties as aggregate material and had been used in Canada, the United States, and elsewhere for road construction and other purposes for many years. However, because of concerns related to the radioactivity of the silicates, many such uses were prohibited by a number of jurisdictions, including the Province of Quebec which issued a ban on further selling of the silicates. Because this ban, and the associated requirements for disposal of the silicates, potentially affected the viability of the phosphorus producer, SENES Consultants Limited was asked to make an assessment of the potential radiation exposures that might result from various proposed uses of the silicates. In addition, as part of a separate comprehensive industrial hygiene survey of the plant, radiation exposures to the workers at the plant were also assessed. This paper reports on both the worker exposure estimates, and the estimated potential exposures to members of critical groups associated with various proposed applications of the silicates.

POTENTIAL EXPOSURE PATHWAYS

Occupational Exposure

The workers are exposed to direct gamma radiation, to airborne particulates, and to radon-222. Because of the high temperature process, essentially all the radon and more than 95% of the relatively volatile radionuclides, lead-210 and polonium-210, are released to the process air (1). As shown in Table 1 which gives the radiological analysis of five silicate samples, the remaining radionuclides report to the silicates. Thorium-230 and radium-226 were in approximate equilibrium with the uranium while lead-210 and polonium-210 were much below equilibrium. The increase in the concentrations of lead-210 (and its decay product polonium-210) with age of the silicates is evident. The average uranium concentration in the silicates was equal to that measured in the phosphate ore.

The radon release fraction shown in Table 1 is defined as the ratio of the measured radon release rate of the sample to the theoretical maximum release rate calculated from the radium-226 concentration. The average release fraction of 0.0028 is about a factor of 60 below the 0.2 fraction often quoted for typical soils. The average release fraction from three ore samples was measured as 0.026. These results are consistent with results reported elsewhere (e.g. 2,3). Apparently, the dense ceramic matrix of the silicates greatly inhibits the release of radon. Additionally, track-etch radon detectors placed in the refinery did not measure any above-background levels of radon. Radon was therefore not considered in the exposure assessment. The worker monitoring program was based on the use of portable personal respirable air samplers to measure airborne radioactivity in potentially elevated areas (two week program) and thermoluminescent dosimeters (TLDs) (three month program). Standard breathing rates and inhalation dose conversion factors (4) were used with the exception that the polonium-210 and lead-210 particles were assumed to have an AMAD of 0.3 μm rather than the standard default value of 1 μm (1). The new 1990 ICRP recommendations (5) would produce somewhat lower dose estimates.

Exposure of the Public

Based on the good aggregate properties of the silicates and on experience with previous uses, a number of potential applications for the silicates were proposed by the phosphorus producer. These included uses such as base for railroads and highways, massive fill for large industrial areas, and massive fill for highway overpasses. Because of the very low radon emanation and the measured low leachability of the silicates, the only significant exposure pathway was gamma exposure. Exposures were based on the product of assumed exposure time, and exposure rate derived from the exposure rate measured on top of massive, uncovered silicates (up to 150 $\mu\text{R/h}$) and attenuation of any cover used in the various applications.

RESULTS

Worker Exposures

The estimated inhalation exposures for four workers in the distillation area of the refinery averaged 2.5 mSv/y (range 2.1 to 3.3 mSv/y); exposures in other areas of the plant were lower. Doses from uranium, thorium-230, radium-226, lead-210 and polonium-210 averaged 0.1, 0.1, <0.1, 0.6 and 1.6 mSv/y, respectively. The results show the relative importance of lead-210 and polonium-210, the more volatile radionuclides. The "residue" remaining after distillation of the phosphorus contained concentrated levels of these two radionuclides, greater than 500 Bq/g. For this reason, careful handling and disposal of the residue was recommended. Estimated gamma exposures ranged from 0.2 to 2.4 mSv/y, with an average of 0.8 mSv/y. Unlike inhalation exposures, the highest gamma exposures were recorded by workers who spent most of their workday near the ore or silicate storage piles. Total exposures were estimated at less than 5 mSv/y for all workers.

Exposure from Proposed Uses of Silicates

The maximum exposure rate of 150 uR/h for uncovered, massive silicates was used as a starting point in all the exposure estimates. The results shown in Table 2 for some proposed uses, assuming $1 R = 0.007 Sv$, are dependent on the assumed exposure times e.g. 2 h/day for use of roads. All estimates were less than 1 mSv/y for the exposure assumptions used.

CONCLUSIONS

Exposures to phosphorus refinery workers ranged up to about 5 mSv/y, with inhalation of polonium-210 and lead-210 being major contributors to the exposures. Public exposures to various proposed uses of the by-product silicates were estimated as being less than 1 mSv/y for the assumed exposure times.

REFERENCES

1. United States Environmental Protection Agency, 1989. "Risk Assessments - Environmental Impact Statement for NESHAPS Radionuclides - Background Information Document - Volume 2". Report EPA/520/1-89-006-1, September.
2. Lloyd, L.L., 1983. "Evaluation of Radon Sources and Phosphate Slag in Butte, Montana." Occupational Health Bureau, Department of Health and Environmental Sciences, Report EPA/520/6-83-026, June.
3. Radiation Protection Bureau, Canada Department of National Health and Welfare, 1978. "Radiation Survey of Long Harbour, Newfoundland." In: Task Force on Fluoride, Canadian Public Health Association.

4. International Commission on Radiological Protection, 1979. "Limits for Intakes of Radionuclides by Workers." ICRP Publication 30 and supplements.
5. International Commission on Radiological Protection, 1991. "Annual Limits on Intake of Radionuclides by Workers Based on the 1990 Recommendations." ICRP Publication 61, Annals of the ICRP, Vol. 21, No. 4.

Table 1: Radiological Analysis of Silicates

Sample Description	U-nat (µg/g)	Th-230 (Bq/g)	Ra-226 (Bq/g)	Pb-210 (Bq/g)	Po-210 (Bq/g)	radon release fraction
pelletized silicates, age unknown	170	2.0	2.0	0.25	0.12	not done
pit-cooled silicates, age unknown	206	2.5	2.0	0.30	0.14	not done
silicates, 1 month	200	3.2	2.3	0.02	<0.01	0.0017
silicates, 24 months	217	3.1	2.6	0.18	0.14	0.0032
silicates, >54 months	199	2.7	2.4	0.61	0.42	0.0034
average	198	2.7	2.3	0.27	0.17	0.0028

Table 2: Estimated Annual Doses from Proposed Uses of the Silicates

Application	Exposure Rate (µR/h)	Exposure Duration (h/y)	Annual Dose (mSv/y)
Equipment storage area	150	500	0.53
Railroad Base	50-100	730	0.26-0.51
Base for Underground Pipes	50-100	40	0.26
Highways	50	730	0.26
Ditches and Berms	50-100	40	0.01-0.03
Overpasses	150	100	0.11

THE PRACTICAL IMPLICATIONS OF THE NEW ICRP
ANNUAL DOSE LIMIT AT OLYMPIC DAM OPERATIONS

Jim Hondros
Olympic Dam Operations
Box 150, Roxby Downs
S.A. 5725

ABSTRACT

The radiation protection mechanisms in place at Olympic Dam Operations have been proven to be adequate for the control of employee radiation doses. The introduction of the new ICRP average annual dose limit of 20 mSv per year resulted in a review of the existing radiation protection mechanisms to ensure that their adequacy was sufficient. This paper will overview the existing radiation protection mechanisms and present the practical implications of the new ICRP limit as they apply to operations at Olympic Dam.

APPROACH TO RADIATION SAFETY

Olympic Dam Operations is a copper, uranium, gold and silver producer located approximately 600 km north of Adelaide in South Australia. The Operations consist of an underground mine and a multifunction metallurgical processing plant. The Operations have been in production since 1988 and employs approximately 800 people.

The company approach to radiation safety has revolved around designing the workplace to control employee exposure to radiation. Initial design criteria for the underground mine was that average doses to employees would be less than one quarter of the 50 mSv annual limit. Similarly, the use of good design and procedures are used for the control of radiation in metallurgical processing plant.

It must also be recognised that in the mining and processing of radioactive ores, radiation is only one of a number of hazards that is required to be managed and controlled. Radiation is a chronic exposure hazard and when compared to the more traditional mining and processing hazards such as; rock falls, chemicals and manual handling, it is relatively minor. However, an active managerial approach to radiation safety ensures that radiation is controlled and that employee exposures remain low.

RADIATION PROTECTION MECHANISMS

The major employee exposure pathways in the mining and processing of radioactive materials are; irradiation by gamma radiation, inhalation of radon daughters and inhalation of radioactive dust. The following radiation protection mechanisms are used in the control of radiation in the underground mine and metallurgical plant.

i) Mine

The control of gamma radiation in practice, is by selecting the mining method, such that there is no entry into the actual mineralised area. All access to the ore is from outside the ore body. This effectively shields employees from the gamma radiation. In the event that entry into the ore body is required, for exploratory reasons for example, then maximum exposure times are calculated from the measured gamma dose rates.

The underground ventilation system is designed to provide at least a fixed quantity of fresh air to each workplace, based on theoretical calculations prior to underground development. Experience at Olympic Dam has shown that the ventilation capacity required to control the radon daughter hazard is sufficient to control the other airborne hazards including radioactive dust.

To ensure that the ventilation system remains in optimum operating condition, it is necessary that it be maintained. This includes routine maintenance of the physical components of the ventilation system and the quick repair of any damages that occur during operations.

Formalised written procedures exist for work areas that may be inadequately ventilated as determined by the monitoring. Access to these areas is restricted to authorised personnel with appropriate personal protective equipment. Access is usually for ventilation maintenance and monitoring purposes. Prior to any change in the ventilation system, the ventilation officers and radiation safety officers are consulted to determine any possible effects on other workplaces.

Major ventilation installations are expensive and must be planned well ahead of their intended time of use. Experience to date has proven the need to properly schedule mining work in different areas. Non planned work may affect the operation of the whole ventilation system resulting in inadequate capacity in some areas. Therefore, the aim is to adhere to the established work schedules thereby ensuring adequate ventilation. If changes in schedules are necessary then considerable thought needs to be given to the specific ventilation requirements. Active management of the planning of the ventilation capacity is an integral part of the production and development of the mine.

Control of radioactive dust in the design stage initially involves the identification of potential dust sources. Physical control mechanisms and good work procedures for the control of dust include;

- flow through dilution ventilation in work areas,
- water sprays in ore handling areas,
- extraction ventilation in ore handling areas where the use of water is inappropriate,
- the watering down of roadways to prevent the resuspension of road dust,
- the use of water for all drilling operations to suppress dust,
- the use of water on all newly broken rock to suppress dust.

The use of personal protection, usually respirators, for the control of airborne radiation exposure is the least preferred control option, however it is useful in the pursuit of maintaining exposures as low as possible. Personal protection acts as a fallback control mechanism, but is not relied upon as a long term option.

ii) Metallurgical Processing Plant

Most of the total dose to employees at the metallurgical plant is delivered via the inhalation of radioactive dust. The control of radiation therefore primarily revolves around the control of potential dust sources. Specific design criteria for the packaging of uranium oxide involved installation of an isolation booth operating under negative pressure. Other potential dust sources arise from spillages of process material. Consequently, the processing plant was designed for ease of clean-up of any spillages. Areas beneath potential spillage points, for example; tanks and grinding mills, are fully concreted with bunding and sumps. Water outlets are abundant for hosing up of spillages. Strict operating clean-up procedures are enforced, with the aim being, not to let spillages dry and become dust sources.

Extraction ventilation systems are used to control identified dust sources and these systems receive routine maintenance. The use of personal protective equipment, usually respiratory protection, is mandatory for a number of tasks including; uranium packaging and clean-up of dried spillages.

IMPLICATIONS OF NEW ICRP LIMIT

Total radiation doses to mine and metallurgical plant workers show that the existing radiation protection mechanisms outlined in this paper are adequate and effective in controlling the doses to employees. For the period July 1990 to June 1991, annual doses, on average, were one quarter of the new ICRP average annual dose limit and the maximum doses were less than 70 percent of the new limit.

At the beginning of 1991, a series of discussions with the South Australian state regulatory authorities occurred in an attempt to determine the implications of the new ICRP annual dose limit on operations at Olympic Dam. As a result of these discussions, a number of agreed objectives were established. These were as follows;

i) To maintain and improve existing radiation protection mechanisms.

As stated, existing radiation protection mechanisms are adequate for maintaining employee doses below the new ICRP average annual dose limit. However, on-going review of existing mechanisms, and formalisation of existing and new procedures will be actively pursued to ensure that doses remain low.

ii) To more accurately assess employee doses by reducing random errors and reducing systematic errors.

The reduction of the margin between assessed doses and the new ICRP limit, compared to the old ICRP limit, implies that there is a need to ensure that the magnitude of the error in dose assessment is low enough to maintain compliance.

The magnitude of the random error in dose assessment is primarily a function of the statistical significance of the physical measurements used for dose estimation.

Systematic errors in dose assessment are biased due to deliberate over estimates for conservative dose assessment. Replacement of default parameters in the ICRP dose assessment methodology, with actual workplace measurements, reduces the magnitude of the systematic error and increases accuracy. Systematic errors will be reduced with the use of particle size measurements and radionuclide in dust analyses.

iii) To pursue personal dosimetry.

Another way to increase the accuracy of dose assessment is to use personal dosimetry. A number of systems are commercially available for radon daughters, however, their adequacy for the conditions and environment must be assessed. At Olympic Dam, the use of passive radon monitors and workplace equilibrium factors are being investigated. To complement the passive devices, it is planned to use active radon daughter dosimeters to monitor critical workgroups. Prototype monitors are currently being tested at Olympic Dam.

iv) To develop better reporting of doses.

To complement the monthly report on monitoring results, a quarterly report is now being generated which presents the assessed doses for individuals for the three months. The timely reporting of employee doses to managers results in closer control of the overall annual doses. Also contained in the report are the dose parameter monitoring results used to reduce the systematic error in dose assessment.

CONCLUSION

Existing radiation protection mechanisms at Olympic Dam Operations are adequate to ensure compliance with the new average annual ICRP dose limit. However, a number of specific requirements have been identified to ensure that employee radiation dose will continue to remain low and well controlled.

ACKNOWLEDGEMENT

The author would like to thank the Olympic Dam Joint Venture Management Committee for permission to publish this paper.

PARAMETERS FOR CHARACTERIZATION OF RADON ADSORPTION AND
DIFFUSION IN POROUS MEDIA

G. Curzio, F. d'Errico, A. Mori*, A. Gentili†

Dipartimento di Costruzioni Meccaniche e Nucleari (DCMN)
Università degli Studi di Pisa, Pisa, ITALY

* ENEA, Dipartimento Ingegneria Ambientale, Pisa, ITALY

† CRESAM, San Piero a Grado, Pisa, ITALY

ABSTRACT

Theoretical models and experimental methods are described for the determination of parameters used in the analysis of Radon adsorption and diffusion in porous media.

INTRODUCTION

Adsorption on activated charcoal is a phenomenon widely used for the measurement of Radon concentration in air.¹ Following exposure to an unknown atmosphere, the Radon content in a charcoal canister is derived from the γ -emission of its decay products, at radioactive equilibrium. Radon concentration in the air is then usually inferred by comparing the above mentioned γ -activity to the activity resulting from exposure to a known Radon concentration.

The Nuclear Instrumentation and Measurements Laboratory of DCMN is involved in the definition of the Italian standard for Radon measurement by means of activated charcoal. Among the goals of this effort is the identification of simple and accurate procedures for the determination of two fundamental parameters governing Radon permeation in porous media: adsorption and diffusion coefficients.

THEORETICAL MODELS AND EXPERIMENTAL MEASUREMENTS

Adsorption coefficient. This coefficient is found by injecting a gas pulse into a charcoal column open at both ends and analyzing the temporal evolution of the gas concentration at the outlet.^{2,3}

A mathematical description of the pulse shape through the porous medium is given by the "theoretical plate model," borrowed from the analysis of plate distillation columns, which treats adsorption as a discrete process. The adsorbing column is regarded as a series of N chambers of height H where immediate equilibrium is reached between mobile and stationary phases. The pulse shape through the filter can be deduced, at any time t , from a mass balance, setting an initial condition of zero concentration in all the plates but the first one, where the input pulse is assumed as uniformly distributed. This yields:

$$C_N(t) = A \cdot \frac{N^N \cdot Q^{N-1} \cdot t^{N-1}}{(N-1)! \cdot (k \cdot m)^N} \cdot e^{-(N \cdot Q \cdot t / k \cdot m)}$$

The gas concentration at the outlet, calculated from this expression, is:

$$C_N(t) = \left(\frac{N \cdot Q \cdot t}{k \cdot m} \right)^{N-1} \cdot e^{-(N \cdot Q \cdot t / k \cdot m)}$$

The time t_{MAX} , at which the output concentration is maximum, and the time interval $\Delta t_{1/2}$, (FWHM), may be easily derived from experimental elution curves (Figure 1). The number N of the theoretical plates may be then deduced from the relation between $\Delta t_{1/2}/t_{MAX}$ and N , reported in Figure 2. The relation between t_{MAX} and the average retention time, \bar{t} , is: $t_{MAX} = \bar{t} \cdot (N-1)/N$.

Finally, the adsorption coefficient K , relative to a column containing a charcoal mass m and crossed by an air flow Q , may be calculated from the expression: $K = (\bar{t} \cdot Q / m)$.

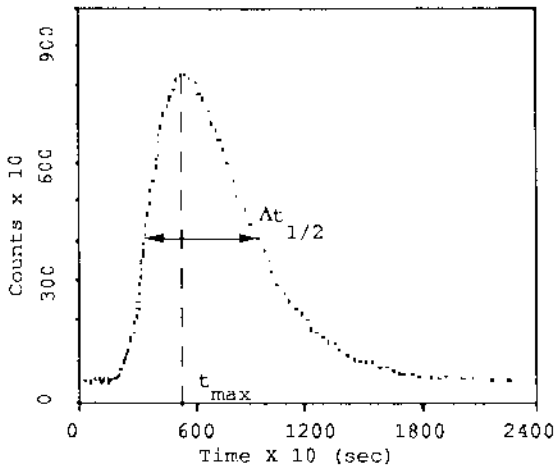

Figure 1. Elution curve

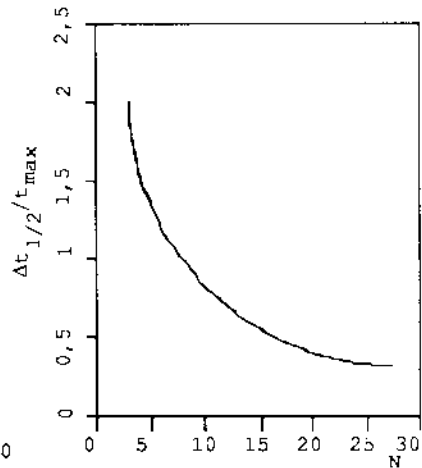

Figure 2. $\Delta t_{1/2} / t_{max}$ as a function of N

Effective diffusion coefficient. In order to measure the coefficient D_e , a charcoal column with one open end is exposed to a Radon atmosphere until a uniform concentration C_0 is reached throughout its height, a . A continuous flow of air then sets at zero the upper free surface concentration, while the γ -emission from Rn daughters is monitored with time. With these initial and boundary conditions, integration of the set of differential equations describing the process of combined elution and decay

$$\frac{\partial C}{\partial x} = D_e \frac{\partial^2 C}{\partial t^2} - \lambda C$$

$$C(0, x) = 0$$

$$C(t, a) = 0$$

$$\left[\frac{\partial C}{\partial x} \right]_{t, x=0} = 0$$

yields a concentration profile along the column axis which approaches a single sinusoid when $t > \frac{1}{2 D_e} \left(\frac{a}{\pi} \right)^2$.

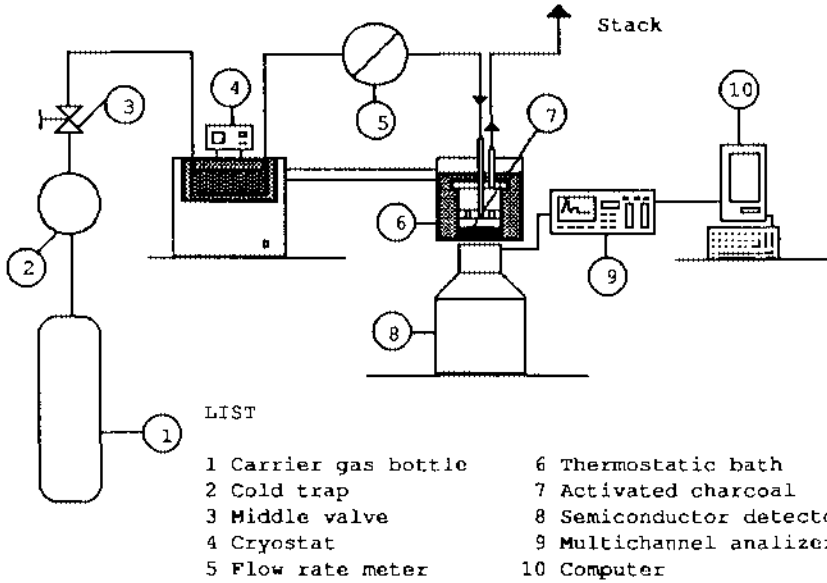

Figure 3. Test-rig

In this case, the distribution of radioactive isotopes inside the charcoal column does not vary with time, therefore, the geometric efficiency of a γ -detector placed near the column is constant. This allows for the measurement of the decrease of activity:⁴

$$A(t) = \frac{8 C_0 a}{\pi^2} e^{-\left[D_e \left(\frac{\pi}{2a} \right)^2 + \lambda \right] t} \quad t > \frac{1}{2 \cdot D_e} \left(\frac{a}{\pi} \right)^2$$

The value of the constant $\left[D_e \left(\frac{\pi}{2a} \right)^2 + \lambda \right]$, where the diffusion coefficient D_e is the only unknown quantity, may be calculated through exponential interpolation of the experimental data, as shown in Figure 4.

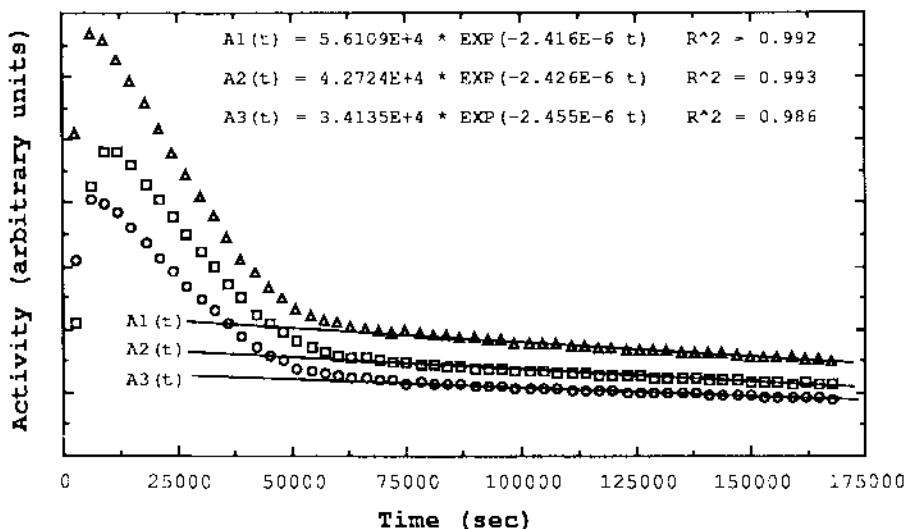

Figure 4. Temporal evolution of the γ -activity of the three most pronounced peaks of the Radon daughters spectrum.

CONCLUSIONS

At DCMN we can measure all the quantities that characterize the response of an activated charcoal canister exposed to constant conditions until equilibrium is reached with both environmental humidity and Radon. Based on these data, we are developing the analysis of the canister response when conditions of exposure undergo dynamic transients.

REFERENCES

- 1 Curzio, G., Gentili, A., Mori, A., Remiddi, E., Sciocchetti, G., and Rinaldi Fornaca, G., 1989, Misure di concentrazione di Radon mediante adsorbimento su carbone attivo, Proc. XXV Congresso Nazionale AIRP, Verona, 13-15 September 1989.
- 2 Van Deemter, J.J., 1956, Longitudinal diffusion and resistance to mass transfer as causes of non-ideality in chromatography, Chem. Eng. Sci., 5, p. 271.
- 3 Curzio, G. and Gentili, A., 1972, Libération de gas nobles par les centres nucléaires: quelques remarques sur le fonctionnement des filtres de charbon de bois, Proc. VI^e Congrès International of the Société Française de Radioprotection, Bordeaux, 27-30 March 1972.
- 4 Castellani, F., Curzio, G. and Gentili A., 1976, Krypton diffusion in granular charcoal, Analytical Chemistry Vol. 48, N° 3, pp. 599-600.

INTERCOMPARAISON DE L'EMANATION RADON DE PHOSPHATES DE DIFFERENTES ORIGINES (MAROC et TUNISIE)

A. Knalil*, F.Membrey*, D.Klein*, A.Chambaudet* et R.Iraqi**

* Laboratoire de Microanalyses Nucléaires, U.F.R. des Sciences et Techniques, Université de Franche-Comté, 25030 Besançon, France

** Centre de Recherches sur les Phosphates (CERPHOS) 73 à 87 Boulevard Moulay Ismail Casablanca, Maroc

INTERCOMPARISON OF RADON EMANATION IN MOROCCAN AND TUNISIAN PHOSPHATE ROCKS

ABSTRACT

We suggested a method for measuring the emanation of radon gas of phosphates mineral from different origins using solid state track nuclear detectors (CR39 and LR115) with the aim to demonstrate radioactivity effects on the human.

1- INTRODUCTION

Les phosphates sédimentaires, de part leur mode de formation géologique contiennent les isotopes ^{238}U et ^{235}U de l'uranium, à l'état de traces, ainsi que leurs descendants. Parmi ceux-ci le radon, élément radioactif gazeux, émane de ces minerais et se retrouve dans l'air avoisinant. On conçoit donc qu'en détectant ce gaz et en le mesurant, on puisse l'employer comme traceur pour le suivi de la radioactivité dans les sites d'extraction et d'exploitation des phosphates.

En vue de cela, une méthode simple est proposée pour mesurer l'émanation du gaz radon: il s'agit d'une approche par détecteurs solides de traces nucléaires (DSTN)

Toutes les mesures sont effectuées en laboratoire, sur des échantillons de phosphates prélevés sur différents gisements (Maroc, Tunisie). Dans le cadre de cette étude préliminaire, nous avons comparé les émanations en radon issu de ces minerais afin d'évaluer l'activité volumique due à ce gaz.

2- LE RADON

Gaz radioactif, le radon existe dans la nature sous forme de trois isotopes: l'Actinon ^{219}Rn de la famille de ^{235}U , le Thoron ^{220}Rn de la famille de ^{232}Th et le Radon ^{222}Rn issus de la famille de ^{238}U . A cause de leurs périodes respective (3,9 s ; 55 s et 3,8 j), seul le ^{222}Rn peut être utilisé comme traceur pour le suivi de la radioactivité dans les gisements de phosphate.

Le radon 222, résulte du radium 226 par désintégration alpha. La mesure et le suivi de la concentration du radon 222 présente également un intérêt majeur en radioprotection, ce gaz étant le principal composant de la radioactivité atmosphérique. Ce gaz présente donc un risque radioactif dans et autour des gisements de phosphates qui présentent des teneurs non négligeables en éléments radioactifs (de l'ordre de la centaine de ppm) et c'est une raison supplémentaire pour réaliser la mesure du potentiel d'émanation en radon.

3- MESURES DE L'EMANATION EN RADON 222

3.1- Détecteurs Solides des Traces Nucléaires (DSTN)

3.1.1- Caractéristiques

Le passage d'une particule (ici particule alpha) chargée dans un diélectrique minéral ou organique, entraîne l'apparition d'une zone de dépôt appelée "trace latente". Un traitement chimique approprié permet de développer ces traces latentes pour les rendre visibles et mesurable en microscopie optique. Dans notre étude nous avons utilisé deux types de DSTN : un polycarbonate d'allyl diglycol (CR39) et un nitrate de cellulose (LR115)

DSTN	Nom commercial	Plage de détection en énergie (MeV)	Révélation par voie chimique
Nitrate cellulose	LR115 (Kodak)	1,5-4,5	2,5N (NaOH) 60°C - 1h30
Carbonate d'allyl	CR39 (Tastrak)	0,1->20	7N (NaOH) 70°C-3 à 6h

Tableau: Caractéristiques des détecteurs solides de traces nucléaires utilisés

3.1.2- Réponses des DSTN (CR39 et LR115)

Une étude de la réponse des DSTN (CR39 et LR115) en fonction du temps a été réalisée, sur une période de 20 jours (Fig.1). On observe que la réponse des deux DSTN est proportionnelle au temps. Par ailleurs, dans cette expérience, et avec les conditions de développements employés, on constate une sensibilité 7,5 fois plus grande de CR39 par rapport au LR115. Ceci peut s'expliquer par des plages de détection en énergie différentes (cf. tab.1) et par des types de traces développées dissemblables.

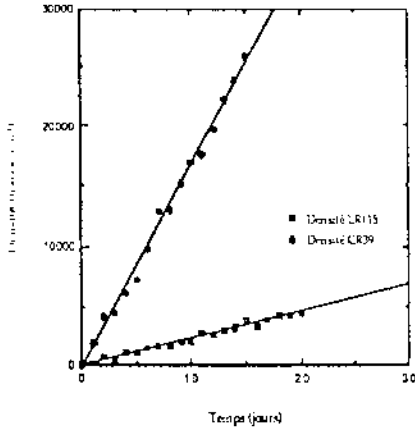

Fig.1: Evolution de la densité de traces avec le temps

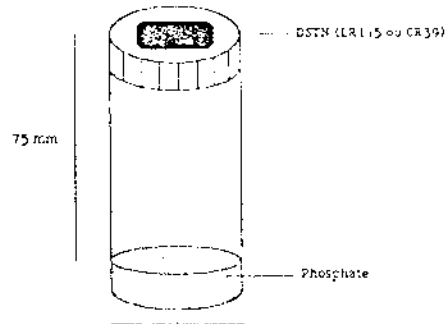

Fig.2: Schéma de principe d'un dosimètre

3-2. Détermination des conditions expérimentales

Une étude préliminaire est réalisée pour déterminer les conditions optimales pour mesurer l'émanation en gaz Radon. Ces mesures sont réalisées pendant 30 jours en laboratoire avec des dosimètres (fig.2) contenant 15 g de phosphates.

Les échantillons de phosphates sont tamisés pour séparer les grains de phosphates de différentes tailles, la mesure de l'émanation en gaz radon est réalisée sur dix fractions granulométriques de 80 à 1000 μ . On a mis ainsi en évidence que l'émanation est la plus importante pour la fraction comprise entre 315 et 500 μ (fig.3). Nous avons donc adopté cette fraction granulométrique, pour la suite de notre travail.

3.2.2- Détermination de la distance DSTN-surface de phosphate

Nous avons comparé les densités de traces alpha enregistrées par les DSTN en fonction de la distance DSTN-surface de phosphate (fig.4); on observe sur celle-ci qu'à partir d'une distance de 7,5 cm il existe un palier. On peut en déduire qu'à partir de cette hauteur, seules les désintégrations alpha du radon 222 sont enregistrées.

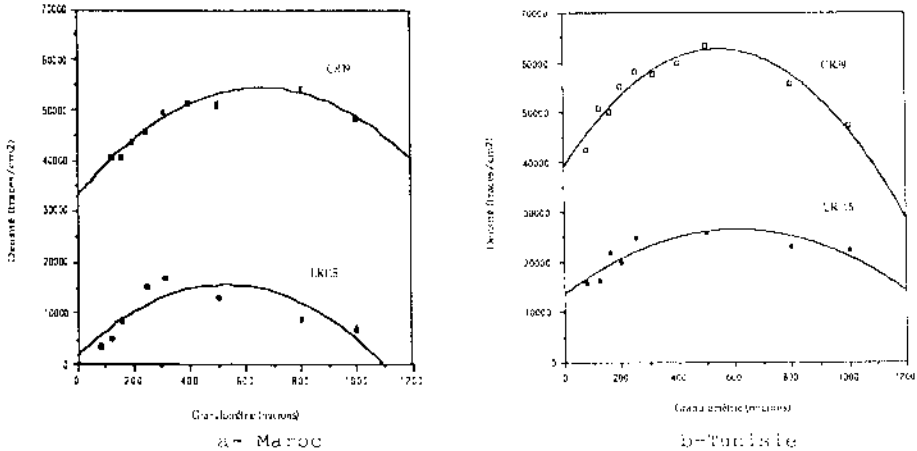

Fig.2: Evolution de l'émanation en radon en fonction de la granulométrie

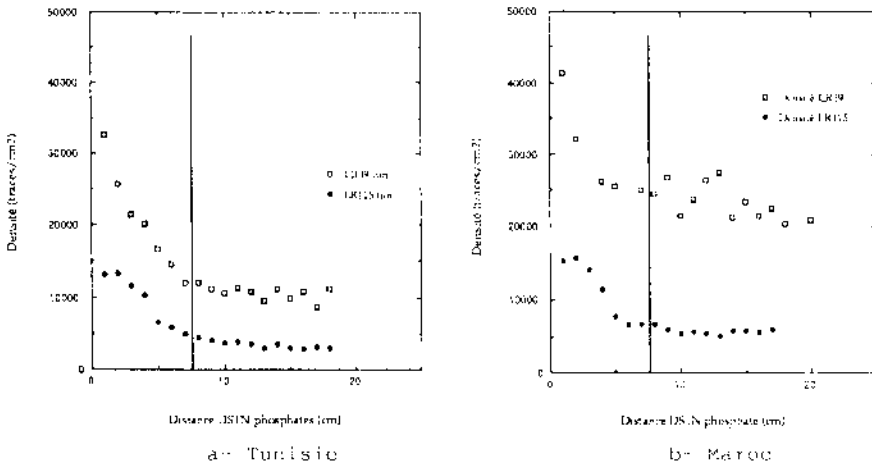

Fig.3: Evolution de la densité de traces en fonction de la hauteur

3.3- Détermination du potentiel d'émanation en radon 222

3.3.1- Choix des phosphates

3.3.1- Choix des phosphates

Nous avons effectué des mesures sur des échantillons de phosphates prélevés sur les gisements de Gafsa en Tunisie et de la région de Gantour au Maroc.

3.3.2- Résultats

Au Laboratoire, une source de radon et des appareils de mesures en continu nous ont permis d'étalonner la réponse en radon des DSTN utilisés. D'après cet étalonnage, nous avons pu déterminer l'activité en radon 222 dans les phosphates.

Phosphates	Densité (traces/cm ²)	Activité volumique (Bq/m ³)	Activité volumique/heure (Bq/m ³ /h)
Gantour (Maroc)	CR39 21500	16348,09	22,7
	LR115 5460	18357,78	25,49
Gafsa (Tunisie)	CR39 10654	8022,94	11,142
	LR115 3756	12215,032	16,96

Une étude comparative a été réalisée en spectrométrie gamma à partir d'un détecteur Ge(hp) pour évaluer la concentration en uranium dans ces phosphates. Les résultats sont cohérents avec ceux obtenus par la méthode des DSTN.

4- CONCLUSION

Cette étude préliminaire a montré qu'il est possible d'effectuer la mesure du potentiel radon des phosphates par DSTN. Cette grandeur est en effet primordiale pour, d'une part estimer les tonneaux en radioéléments dans ces phosphates et d'autre part évaluer leur risque radiologique.

BIBLIOGRAPHIE

- (1)- M. BERRADA, A. CHOUKRI et T. ELKHOUKHI; Uranium, Radium, and Radon emanating rates of Moroccan Phosphate samples. Workshop on Radon monitoring. Trieste (1989).
- (2)- J.P. JEANMAIRE. Les déséquilibres radioactifs(U-Ra) de l'Uranium du gisement de phosphate de Gantour (Maroc occidental).Sci. Géol., Bull (1987).
- (3)- A.PETER FEWS and DENIS L HENSHAW. Alpha particle autoradiography in CR39: a technique for quantitative assessment of alpha-emitters in biological tissue.Phys. Med. Biol (1983).
- (4)- R. BARILLON. communication personnelle.

MEASUREMENTS OF REGIONAL DISTRIBUTION OF ^{222}Rn CONCENTRATION
and ANALYSIS ON OPTIMAL ALLOCATION OF MONITORING STATIONS

Hirokuni YAMANISHI¹, Yukitaka TKEBE and Takao IIDA

Department of Nuclear Engineering, Faculty of Engineering,
Nagoya University, Chikusa-ku, Nagoya 464 01, Japan

ABSTRACT

Outdoor ^{222}Rn concentrations were measured with electrostatic integrating radon monitors (EIRM) at 40 points around Nagoya, in which fifteen sets of 2-month-exposure data over 2.5 years were obtained. Seasonal variation of ^{222}Rn concentration showed a clear pattern which had a spring to summer minimum and an autumn to winter maximum. Annual mean ^{222}Rn concentration ranged from 3.5 to 11.7 Bq m⁻³ depending on locations. From the obtained regional distribution of ^{222}Rn concentration, optimal allocation of measuring instruments was analysed. As a result, it was expected that the same concentration distribution could be obtained with less instruments.

INTRODUCTION

Measurements of regional distribution of ^{222}Rn (radon) concentration have been rare due to lack of proper detectors which enable us to conduct simultaneous measurements at many points for a long time. Information on the regional distribution of ^{222}Rn concentration and its time variation is important to study radon in relation to geological features, ^{222}Rn exhalation, and its behaviour in the atmosphere. Such information is also important to evaluate lung dose precisely. Based on such a background, measurements of outdoor ^{222}Rn concentration were implemented in an area around Nagoya to obtain its regional distribution and time variation.

INSTRUMENT

To measure the regional distribution in large area, monitors should be cheap and maintenance free for a long time. To meet such demands, the most appropriate device will be passive monitors. In this study, we used electrostatic integrating radon monitor (EIRM) developed by Iida et al.⁽¹⁾. It is simple and easy to handle, and can measure low level

¹Present address ; National Institute for Fusion Science,
Chikusa ku, Nagoya 464 01, Japan

outdoor ^{222}Rn concentration as its sensitivity is 20 times higher than cup methods.

The EIRM is a passive ^{222}Rn monitor, which accommodates a cellulose nitrate film and has electrostatic field in its interior to collect charged ^{218}Po . Tracks recorded on the CN films are enlarged by etching for 180 min at 60°C in 2.5 N NaOH solution, and are counted through a microfiche reader. The lowest detectable concentration is 1.2 Bq m^{-3} for a 2-month-exposure.

MEASUREMENTS

The measurements were done in an area within 100 km from Nagoya University. Figure 1 shows the map of the area. The total number of monitoring stations was 40. EIRMs were settled at about 60 cm above the ground. In Nagoya City, the EIRMs were distributed in particular densely so that we could check the data consistency among nearby stations. The period of measurements was from August 1985 to January 1988 at half of the 40 stations, and from December 1985 to March 1987 at the other half. Results were obtained as an average of 2 month interval.

RESULTS

The annual mean ^{222}Rn concentrations are shown in Figure 1. They scatter uniformly between 3 and 12 Bq m^{-3} . The areas of high and low levels correspond to mountainous regions and plains near the sea, respectively. The distribution patterns were nearly the same among the 15 periods while their levels differed largely. The ^{222}Rn concentration at each station was low from spring to summer,

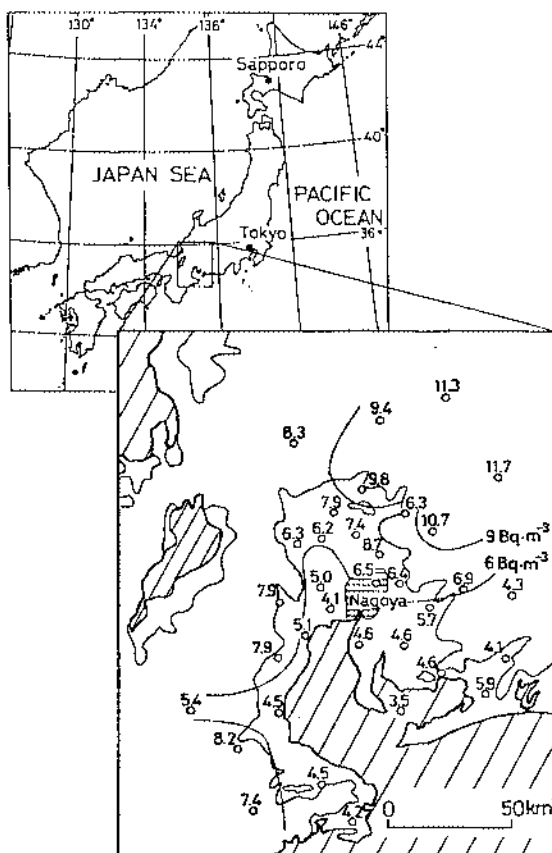

Fig. 1 Map of ^{222}Rn measurement points around Nagoya and annual mean concentrations

and high from autumn to winter. Amplitude of seasonal variations were between factors 1.2 and 2.8. In the mountainous regions, the mean ^{222}Rn concentration was high and fluctuated widely between 6 and 11 Bq m^{-3} . Near the sea, on the contrary, it was low ranging from 3 to 6 Bq m^{-3} .

In Nagoya City, the differences among stations fell within experimental uncertainty. This indicates that the concentration would be almost uniform within an about 10 km scale⁽²⁾, if it is a plain with uniform geology.

OPTIMAL ALLOCATION OF MONITORING STATIONS

When we measure a regional distribution of atmospheric radon concentration, we must solve a problem how monitoring stations allocate. Methods of optimal allocation of monitoring stations have been developed in the field of air pollution monitoring. In the present study we looked for optimal allocation of monitoring stations with the view of measuring a regional distribution as precise as possible with limited measuring instruments.

For simplification of calculation, total area was segmented to "cell" that was a square of 6 km x 6 km. A concentration in one cell was regarded as uniform. A concentration of every cell was estimated with measured value of ^{222}Rn concentration by simple interpolation method.

It was regarded that a certain cell "x" represented cells which were within 25 km from it, and whose concentration differed from that of cell "x" within 1 Bq m^{-3} . Figure 2 shows reset stations and their representative areas. Each monitoring station is indicated by small circle, and its represented cells are marked the same alphabet as the station. If a cell belongs to several

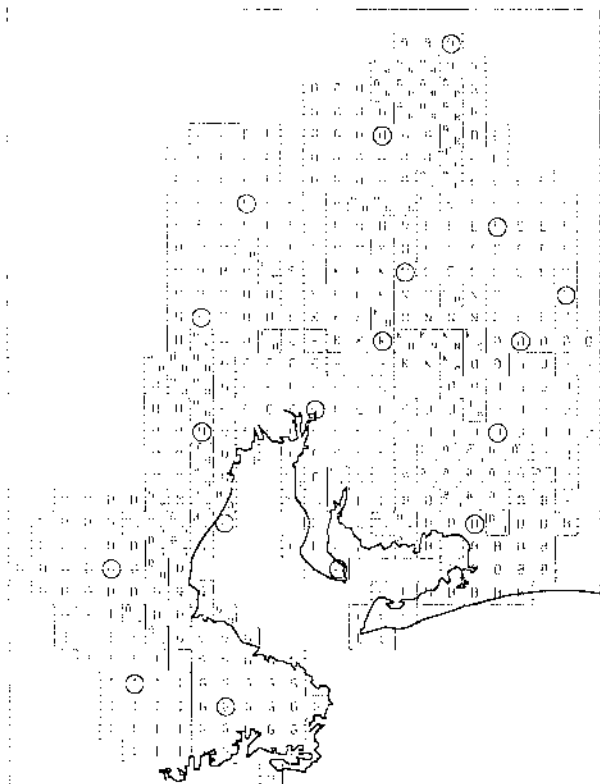

Fig.2 Allocation of monitoring stations and their representative area

representative area. It is put in alphabetical order of stations which occupy it. Summary process of the allocation is described as follows⁽³⁾. In the beginning, representative area was estimated for every cell respectively. The cell whose representative area had the most cells was chosen as the first station. The second station or subsequences was set at a cell which had the largest representative area as a result of subtracting overlap cells with the representative areas of the station set before. In consequence, imaginary monitoring stations were set alphabetically as shown in Figure 2. Fifteen sets of representative area cover 92 % area of all cells.

CONCLUSION

Regional distribution of ^{222}Rn concentration around Nagoya was measured with AIRMs. The concentration had a seasonal variation that it was low in spring to summer and high in autumn to winter. The level ranged from 1.9 to 11.7 Bq m^{-3} in spring, and from 2.3 to 18.9 Bq m^{-3} in autumn. Besides, the concentration was high and fluctuated widely in mountainous regions while it was low and varied to less extent near the sea.

Optimal allocation of monitoring stations was analysed with measured ^{222}Rn concentrations. By selecting new stations whose have large representative area, it was expected that the same distribution of concentration could be obtained with the half stations than existing stations.

REFERENCES

- (1) Iida, T., Ikebe, Y., Hattori, T., Yamashiki, H., Abe, S., Ochiaiji, K., Yokoyama, S.: An electrostatic integrating ^{222}Rn monitor with cellulose nitrate film for environmental monitoring, *Health Phys.*, 54, 139-148, (1988).
- (2) Shimo, M., Ogawa, T., Ogawa, T.: A study on regional representativeness of concentration of radon short-lived daughter products in air, *Hoken Bunsurui* (Jpn. Health Phys. Soc.), (in Japanese), 16, 123-133, (1981).
- (3) Kodak, P.X., Lohan, B.X.: Optimization of ambient air quality monitoring networks (Part 1), *Environmental Monitoring and Assessment*, 5, 1-19, (1985).
- (4) Yamashiki, H., Iida, T., Ikebe, Y., Abe, S., Hata, T.: Measurements of regional distribution of ^{222}Rn concentration, *J. Nucl. Sci. Technol.*, 28(4), 331-338, (1991).

INVESTIGATION ON FOOD RADIOACTIVITY AND ESTIMATION OF INTERNAL DOSE BY INGESTION IN CHINA

H. Zhu, J. Zhang, P. Fan, X. Huang and S. Wang

Institute of Radiation Medicine, Chinese Academy of Medical Sciences, P.O. Box 71, Tianjin 300192, China

ABSTRACT

Activity concentrations of ^{40}K , ^{87}Rb , U , Th , ^{226}Ra , ^{228}Ra , ^{210}Pb , ^{210}Po , ^{227}Ac , ^{14}C , ^3H , ^{90}Sr , ^{137}Cs , ^{144}Ce and ^{106}Ru in 14 categories of Chinese food were determined in 1982-1986. The food samples were collected from normal radiation background area and two elevated natural radiation areas. Based on typical Chinese diet composition, our determined results of the food and reported available typical contents in water, Annual Intake and Committed Dose Equivalent of these radionuclides by ingestion for Chinese male adult were estimated. The total Committed Dose Equivalent is about 0.77 mSv/a. Relative contributions of different categories of food and radionuclides to the total are discussed.

INTRODUCTION

Internal dose of the public from environmental radiation by ingestion depends on radionuclide concentrations in different categories of food (including drinking water) and local dietary habits. Asian dietary habits are quite different from those in other parts of the world. Purposes of this paper are presentation of current levels of important radionuclides in Chinese food and drinking water and estimation of resulting Annual Intake (AI) and Committed Dose Equivalent (CDE).

MATERIALS AND METHOD

Activity concentrations of ^{40}K , ^{87}Rb , U , Th , ^{226}Ra , ^{228}Ra , ^{210}Pb , ^{210}Po , ^{227}Ac , ^{14}C , ^3H , ^{90}Sr , ^{137}Cs , ^{144}Ce and ^{106}Ru in 14 categories of Chinese food were determined in cooperation with 30 radiation protection units during 1982-1986. The samples were collected from 14 provinces, one normal radiation background area and two elevated natural radiation areas. Almost all of the samples were got from lately harvested products. A given radionuclide in all samples was analysed in the same laboratory and measured with calibrated instruments by use of the same standard solution to ensure analytical quality. Almost in the same period as our survey, two other nationwide surveys on contents of some radionuclides in water were accomplished too and some available data have been published recently (1-3).

Based on typical composition of Chinese diet (4), our determined concentrations, reported mean contents of the nu-

clides in water and accepting 1.65 liter/day as mean consumption⁽⁵⁾, AI and CDE of these radionuclides by ingestion for Chinese male adult were estimated.

RESULTS AND DISCUSSION

1. Radionuclide contents in Chinese food and water

The results showed in Table 1 indicate that in normal radiation background area the concentrations of natural radionuclides in food and water were generally higher than those of artificial ones, ⁴⁰K is the highest in food, followed by ¹⁴C, ³H, ⁶⁷Pb, while ³H is the highest in water, followed by ⁴⁰K. In addition, some findings are of significance: quite high concentrations were noticed in certain kinds of food for particular nuclides, for example, tea and kelp for cesium nuclides, pork for ³H, ¹⁴C, ¹³⁷Cs and ⁹⁰Sr, egg for Ra. It was found that the contents of ¹³⁷Cs and ⁹⁰Sr nuclides in samples collected from Yangling high background area were higher than those from normal area, while around the Tsiming area, only contents of H-series nuclides showed to be obviously high.

Table 1. Average concentration range of radionuclides in various food and water

Radionuclides	Concentration range in food, Bq/g or Bq/l	Average concentration in water, Bq/l
⁴⁰ K	2.2-3.4x10 ¹	3.1
⁶⁷ Pb	0.53-1.9x10 ⁻¹	/
³ H	4.4x10 ⁻³ -4.9x10 ⁻¹	7.7x10 ⁻¹
²²⁶ Ra	1.4x10 ⁻² -1.0	1.1x10 ⁻²
²¹⁰ Pb	9.1x10 ⁻² -4.0	6.7x10 ⁻²
²¹⁰ Po	4.0x10 ⁻¹ -4.0	0.8x10 ⁻²
²²⁸ Rn	1.2x10 ⁻³ -0.2	0.1x10 ⁻²
²²⁸ Ra	1.5x10 ⁻² -4.2	0.6x10 ⁻²
²²⁷ Ac	1.3x10 ⁻⁴ -2.2x10 ⁻²	/
¹⁴ C*	7.0-1.47x10 ²	/
³ H*	2.34-13	7.7
⁹⁰ Sr	3.8x10 ⁻² -12	1.37x10 ⁻²
¹³⁷ Cs	3.2x10 ⁻² -1.6	9.6x10 ⁻⁴
¹³⁴ Ce	undetectable-1.0	/
¹⁰⁶ Ru	9.5x10 ⁻³ -5.2x10 ⁻¹	/

* including both artificial and natural sources

2. Public AI of the radionuclides by ingestion in normal radiation background area of China.

The estimation results showed in Table 2 indicate that ^{40}K , ^{14}C , ^3H and ^{87}Rb are the nuclides with more contribution to the total than the others. Most of these AI come from food, while only the AI for tritium and U come from drinking water.

Table 2. Public AI by ingestion for Chinese male adult ($\mu\text{Sv/a}$)

Radionuclide	Food		Water		Total
	AI	%	AI	%	
U Series: U	10.4	34.3	19.9	65.7	30.3
^{226}Ra	22.1	77.0	6.6	23.0	28.7
^{210}Pb	69.1	94.3	4.2	5.7	73.3
^{210}Po	69.8	95.2	3.0	4.8	62.8
Th Series: Th	5.5	89.8	0.6	10.2	5.9
^{228}Ra	30.2	89.3	3.6	10.7	33.8
Others: ^{227}Ac	0.3		/		
^{40}K	2.3×10^4	99.2	1.8×10^2	0.8	2.3×10^4
^{87}Rb	1.3×10^3		/		
^{14}C	1.6×10^4	97.5	4.0×10^2	2.5	1.6×10^4
^3H	2.1×10^3	31.3	4.6×10^3	68.7	6.7×10^3
4 Artificial nuclides	1.1×10^2	92.7	8.6	7.3	1.2×10^2

3. Public CDE of the radionuclides by ingestion in normal radiation background area of China

Based on above mentioned AI, public CDE of these nuclides were estimated and are showed in Table 3. Because

^{40}K in the body is under close homeostatic control, the CDE here is quoted from the world average⁽⁶⁾. It can be seen from the Table that the total CDE was estimated to be about 0.35 mSv, the part contributed by natural nuclides accounted 99.4% of the total, the most important contributors were ^{40}K , ^{210}Pb and ^{210}Po . The estimated value is quite consistent with the world average published in UNSCEAR 1986 Report⁽⁶⁾. The food with the biggest contribution to the total are vegetable, yam, flour, rice and water. In addition, It was found that the total CDE for U Series and Th Series nuclides in Yan jiang high background area were about 2.5 and 6.7 times those in normal area respectively, while in the U mining area, only the CDE of U Series nuclides was 6.4 times that in normal area and the value of Th Series was almost the same as that in normal area.

Table 3. Estimated CDB by ingestion for Chinese male adult

Radionuclide	Food (Sv)	Water (Sv)	Total (Sv)	Relative contribution(%)
U Series: U	6.7×10^{-7}	1.28×10^{-6}	1.95×10^{-6}	0.5
226Ra	6.9×10^{-6}	2.06×10^{-6}	8.96×10^{-6}	2.5
210Pb	9.7×10^{-5}	5.90×10^{-6}	1.03×10^{-4}	28.9
210Po	2.6×10^{-5}	1.30×10^{-6}	2.73×10^{-5}	7.7
Th Series: Th	3.9×10^{-6}	0.44×10^{-6}	4.34×10^{-6}	1.2
228Ra	1.0×10^{-5}	1.19×10^{-6}	1.12×10^{-5}	3.1
Others: 227Ac	1.1×10^{-6}	/	1.1×10^{-6}	0.3
40K			1.80×10^{-4}	50.6
87Rb	1.7×10^{-6}	/	1.7×10^{-6}	1.7
143Gd	9.0×10^{-6}	0.41×10^{-7}	9.41×10^{-6}	2.6
3H	3.5×10^{-8}	7.68×10^{-9}	1.11×10^{-7}	0.0
Artificial:				
90Sr	2.2×10^{-6}	2.97×10^{-7}	2.49×10^{-6}	0.5
137Cs	4.9×10^{-7}	0.4×10^{-8}	4.94×10^{-7}	0.1
144Ce	3.2×10^{-8}	/	3.2×10^{-8}	0.0
106Ru	3.9×10^{-8}	/	3.9×10^{-8}	0.0
Total CDB	1.59×10^{-4}	1.31×10^{-5}	3.51×10^{-4} *	100.0

* including ^{40}K

REFERENCES

1. Liu, Y. Radioactive Levels of Natural Radionuclides in Foods and Water in China, Chinese Journal of Radiological Medicine and Protection, 8 (June) 1-14, 1988.
2. Zhang, J. and Zhu, H. (Eds in Chief), Radioactivity in Chinese Food and Resultant Internal Dose, Chinese Publishing House of Environmental Sciences, Beijing, 1989.
3. Li, Z. (Ed in Chief), Investigation and Evaluation on Radioactive Levels in the network of the Changjiang River, Atomic Energy Press, Beijing, 1988.
4. Jin, D. and Chen, C. (Eds), Summary Report on Nationwide Nutrition Survey in 1982, Chinese Centre of Preventive Medicine, Beijing, 1986.
5. ICRP, Reference Man: Anatomical, Physiological and Metabolic Characteristics, ICRP Pub. 23, Pergamon Press, 1975.
6. UNSCEAR, Sources, Effects and Risks of Ionizing Radiation, UNSCEAR 1983 Report to the General Assembly, With Annexes, United Nations, New York, 1988.

**DETERMINATION OF THE FACTORS THAT CONTROL MIGRATION
AND ENTRY OF RADON INTO BASEMENTS***

T.B. Borak, M.S. Gadd, D.C. Ward, M.S. Barry
Department of Radiological Health Sciences
Colorado State University
Ft. Collins, CO 80523, USA

Elevated concentrations of radon gas indoors are the result of a complicated combination of factors. This report describes results from a facility designed to test and verify theories of radon migration into underground structures. The buildings resemble miniature basements using conventional construction methods, but eliminate other confounding factors introduced by the activities of occupants. Sensors accumulate data on soil properties such as temperature, moisture, pressure differentials, and permeability, as well as outdoor meteorological conditions and indoor environment. Results indicate that indoor radon concentrations do not correlate with changes in the adjacent soil gas concentration or the rate that radon enters the structure. When no attempt is made to control the indoor environment, periods of highest indoor concentration occur when the rate of entry is low. Methods to identify the driving mechanisms and implication for mitigation and control will be described.

*This work is funded through DOE Research Grant DE-FG02-87ER60581.

RADIOLOGICAL OPTIMIZATION IN A REACTOR
DISMANTLING PROGRAMME

Th. Zeevaert, P. Govaerts and P. Crouail*

Studiecentrum voor Kernenergie/
Centre d'Etude de l'Energie Nucléaire (SCK/CEN)
Radiation Protection Research Unit
Boeretang 200
B-2400 Mol, Belgium

and

*Centre d'Etude sur l'Evaluation de la Protection
dans le domaine nucléaire (CEPN)
F-92263 Fontenay-aux-Roses, France

ABSTRACT

The dismantling project of the Belgian nuclear testing reactor BR3, which constitutes the object of a CEC research contract, requires the implementation of the ALARA principle on certain important operations. The major operations of the first phase consist of the decontamination of the primary circuit and the cutting of the thermal shield which are now practically terminated. The radiological optimization study is being carried out in collaboration with CEPN (Centre d'Etude de l'Evaluation de la Protection dans le domaine nucléaire, Fontenay-aux-Roses, France).

A general working sheme was developed, consisting of

- the elaboration of an evaluation methodology for the prediction of doses ;
- the identification and comparison of standard and alternative procedures ;
- the follow-up of the doses during the operation(s) and the feed-back to the predictions.

Aiming at the dose predictions, the operations fore-mentioned were subdivided into unitary or elementary tasks, each of them being characterized by its localization, dose rate, work volume or exposure time and an exposure coefficient.

Concerning the decontamination of the primary circuit, certain measures for dose reduction were identified and their influence on the dose predictions evaluated. As a result of the application of these measures and of the experience from the feed-back of early dose measurements, a reduction of 30 % in dose predictions was calculated. The collective doses observed during the execution of the operations differed from the predicted values by less than 20 %.

As far as the cutting of the thermal shield is concerned a special problem will be formed by the generation of secondary wastes (aerosol, scrap...).

INTRODUCTION

The BR3 reactor is a Pressurized Water Reactor with a

capacity of 11 MWe and had been operated from 1962 to 1987. Actually the SCK/CEN is dismantling or decontaminating certain parts of the reactor. The Commission of the European Communities selected BR3 as a pilot dismantling project for the 1989-93 R&D programme on the decommissioning of nuclear installations. The phases of dismantling/decontamination envisaged or completed until now, include :

- the decontamination of the primary circuit
- the cutting and elimination of the thermal shield (phase 1)
- the segmentation of the lower and upper core support assemblies and of the reactor vessel collar (phase 2)

The total contamination distributed on the inner surface of the primary circuit was estimated at 7 to 11 TBq before decontamination. The main contributors were Co-60 ($\approx 80\%$), Cr-51 (10%), Mn-54 (5%) and Co-58 (4%). Specific β γ activities were comprised between 200 and 1000 kBq/cm². Concerning the reactor vessel (Fig. 1) the neutron-induced activity of the lower and upper core support plates and the thermal shield is very high. For the thermal shield it amounted to 32-87 MBq Co-60/g and 1.0-3.6 MBq Mn-54/g at mid 1989. The activation of the reactor collar is very low due to its great distance from the reactor core.

ORGANIZING RADIOLOGICAL OPTIMIZATION (ALARA)

In recent years the SCK/CEN has done much effort in the field of radiological optimization (ALARA). The effective dose constraint at the SCK installations has been set at 20 mSv.y⁻¹ following international trends of reducing professional dose limits. Evaluations are being made of the feasibility to lower dose constraints still to 10 mSv.y⁻¹.

A project has been set up, including formation of staff members of SCK in ALARA procedures and radiological optimization studies in specific fields. Objects of such studies have been selected in the field of nuclear site restoration and in the field of the dismantling operations at BR3. However not the dismantling as a whole will be envisaged ; only specific parts of it will constitute the objects of the optimization.

Until now radiological optimization has been mainly involved in some large stereotype projects in the field of maintenance at nuclear power stations such as the replacement of steam generators. A dismantling project shows special features while all operations are only executed once. The CEPN (Centre d'étude sur l'évaluation de la protection dans le domaine nucléaire) has been contracted to execute the formation task and to support the radiological optimization of some specific dismantling operations.

DECONTAMINATION OF THE PRIMARY CIRCUIT

In the framework of the decontamination of the primary circuit of BR3 the tasks executed in collaboration with CEPN concerned :

- the choice of the decontamination process from a radio-

logical optimization point of view

- the application of an evaluation methodology for the prediction and analysis of doses
- the organization of follow-up of job-related doses during the operations
- the feed-back from observations to predictions and the drawing of lessons from the experience.

In this stage, the optimization know-how being limited and the procedure of decontamination being nearly determined, based upon the experience of the 1975 decontamination, the identification and comparison of standard and alternative procedures for optimization purposes has not been worked out.

Concerning the choice of the decontamination process, technical requirements already reduced potential processes to LOMI (Low State Transition Metal-ion reagents) and CORD (Chemical Oxidizing Reducing Decontamination). From the point of view of radiation protection and efficiency the two processes were very similar. Nevertheless CORD was designed as the better one since it yielded lower waste volumes. During this evaluation it was also pointed out that irrespective of the decontamination process the potential for workers' exposure is more important during the preparatory phase, when checking the installation and verifying valves, pumps ... (several years after the last outage !), than during the decontamination itself.

The methodology for the prediction and analysis of doses was based upon the principle of dividing the operations into elementary tasks, each of which being characterized by the geographical zone, the dose rate and the volume of work (man.h). The persons required for each elementary task were to be characterized by their speciality (expertise), working conditions and exposure coefficient (the ratio between his individual exposure dose rate and the representative value for the zone). For the calculation and analysis of dose values in this way, the computing programme DOSI ANA of CEPN was applied.

The decontamination of the primary circuit has been divided into approximately 100 elementary tasks, 90 of them being preparatory operations. A first prediction of the total collective dose amounted to 0.199 man Sv, 0.195 man Sv being due to the preparatory phase. From the analysis of the predicted dose some important conclusions could be drawn. Considering an annual individual dose limit of 20 mSv and the different types of expertise required, a total number of 14 technicians were to be provided for, 9 persons of which could reach the annual dose limit within a period of 3 to 4 months. The individual reference level of 2 mSv month⁻¹ was foreseen to be exceeded or attained for a number of 20 elementary tasks.

During execution of the tasks the following-up of doses was carried out applying job-related dosimetry. In that time the dosimeters used were stylo-type ones ; it was recommended that more precise, electronic devices should be applied manageable with processor and PC. With one third of the

elementary tasks executed, the comparison between predicted and measured doses showed an O/P ratio of 0.85. However differences between predictions and observations were considerably higher for some elementary tasks.

At that time it was decided to undertake some dose reduction measures such as the use of biological shielding (lead, wool) on the reactor cover, the filling of some components of the circuits with water and the reduction of the number of bolts to be applied on the reactor cover, which lowered dose predictions with 25 %. Especially the last measure was very effective in this respect.

From the following-up of the job-related doses so far it was also learnt that for rather immobile positions on the operating deck, dose rates had been underestimated and for rather mobile tasks on the pool-bottom the influence of near-by sources overestimated. The correction of these erroneous assumptions yielded another net decrease in predicted doses of 5 %.

A new prediction of doses was then made and a collective dose of 0.142 man Sv was calculated.

The predicted and observed doses are graphically depicted on Fig. 2. As may be noticed the difference between the second prediction and the observations is very small (observed dose: 0.140 man Sv). Decontamination factors between 2 and 16 at various reference points on the primary circuit have been obtained.

CUTTING OF THE THERMAL SHIELD

The cutting of the thermal shield of the reactor has been executed with three techniques in order to gain experience for further segmentation operations. These operations are : electro erosion (in-situ) ; mechanical sawing (in-situ) ; plasma torch (in separate chamber).

Some characteristics of these techniques with respect to the cutting of the thermal shield are indicated in the following table.

	time for cutting 1 m	width of the cut	waste produced for cutting 1 m
electro erosion	29 h	7 mm	4.2 kg
mechanical sawing	2.5 h	4 mm	2.4 kg
plasma torch	3.3 min	11 mm	6.5 kg

Also for these operations a real optimization study could not be started, because of the requirements for technical experimentations which reduced the number of options that could be taken into account considerably, and because of the late introduction of optimization considerations in the planning. It was then decided that experiences from phase 1 and phase 2 operations be used to develop and improve equipment and procedures needed for optimization purposes.

One of the items which had to be improved concerned the

follow-up of job-related doses. Therefore an electronic computerized dosimetric system (GAMMA COM) was put into service. With this system, indications about residence times at different ambient levels of radiation can be obtained.

However in the optimization process for the cutting operations not only external dose rates are important. Other radiological factors such as exposure through other pathways and the generation of waste are very important. During the cutting operations important quantities of solid and liquid waste are generated. These include not only the cutted segments but also secondary waste such as aerosols, ions dissolved in the water, scrap, dross, etc... The finer forms of waste can give rise to internal contamination of the operators if not adequately filtered. The whole package of secondary waste (including filters and resins used for purifying air and water) pose a problem of collection, transport and disposal. The way of solving this problem may also be subjected to an optimization study. Potentials for exposure due to accidental releases have also to be taken into account.

The follow-up of the cutting operations revealed some elementary potentials for dose reduction :

- the unnecessarily high number of personnel present at the working place during certain operations
- the additional number of manipulations which were necessary because of the unavailability of the transport container for the waste in due time
- the obstruction of the working place with equipment and waste offering potentials for accidents and increasing working times

CONCLUSIONS

- For all phases of the dismantling operations at BR3 executed so far, the radiological optimization considerations have been introduced too late. In order to be able to conduct the optimization in an efficient way it must be taken into account from the very beginning.
- Although an efficient optimization has not been possible some interesting experience was gained and important conclusions were derived from the dose prediction and analyses for some operations (e.g. with respect to the number of operators-technicians being necessary).
- The necessity or desirability of the presence of an ALARA coordinator at the site was experienced.
- Radiological factors other than external doses are also to be allowed for in the optimization process (internal contamination, quantities of waste, potentials for exposure).

ACKNOWLEDGEMENTS

This work has been performed in the framework of contract n° F12D-0003-B(TT) with the Commission of the European Communities. The collaboration of the BR3 dismantling project team and of the health physics team of the SCK/CEN,

respectively coordinated by F. Motte and J.P. Deworm, was highly appreciated.

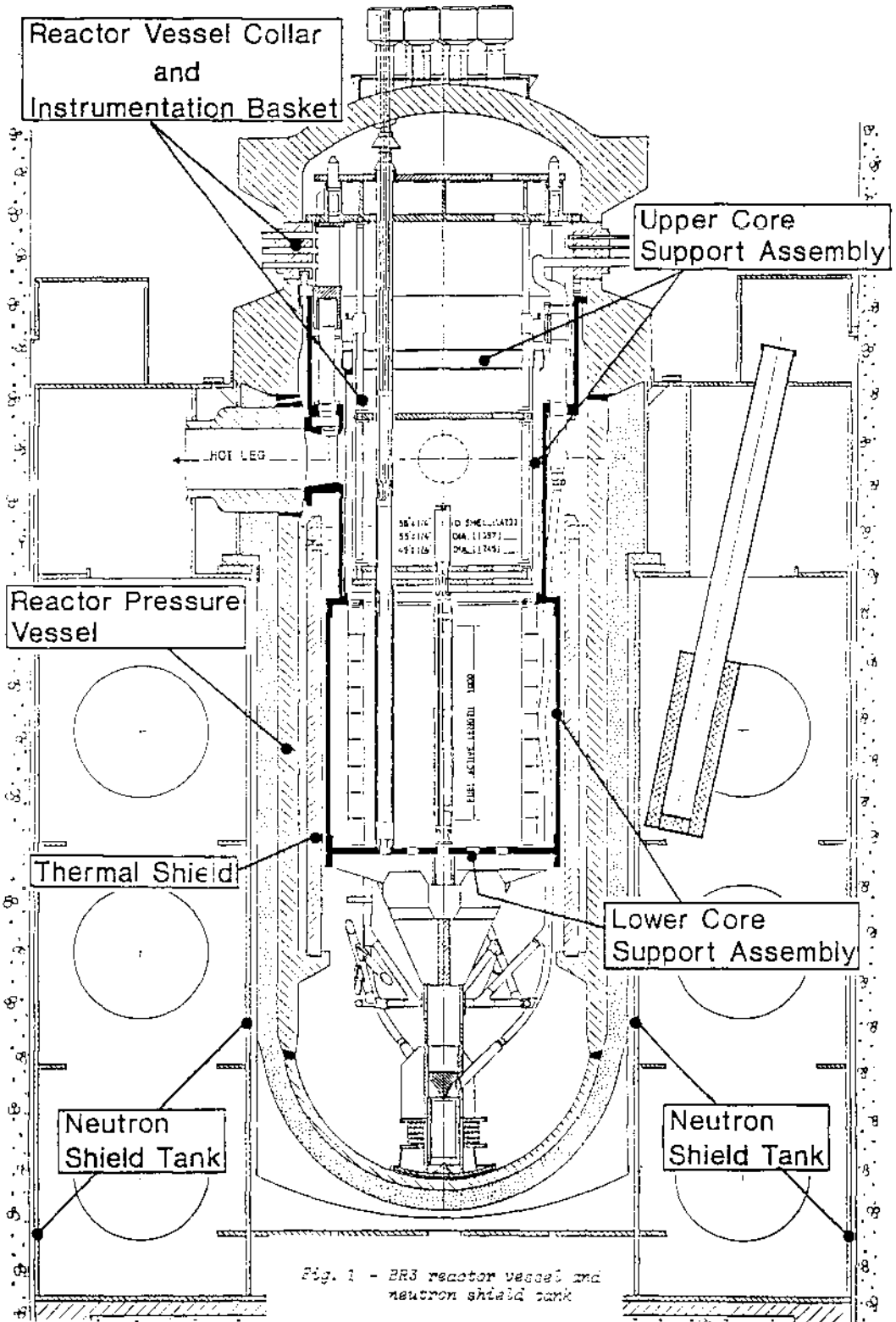

Decontamination Primary Circuit BR3 Cumulative Dose

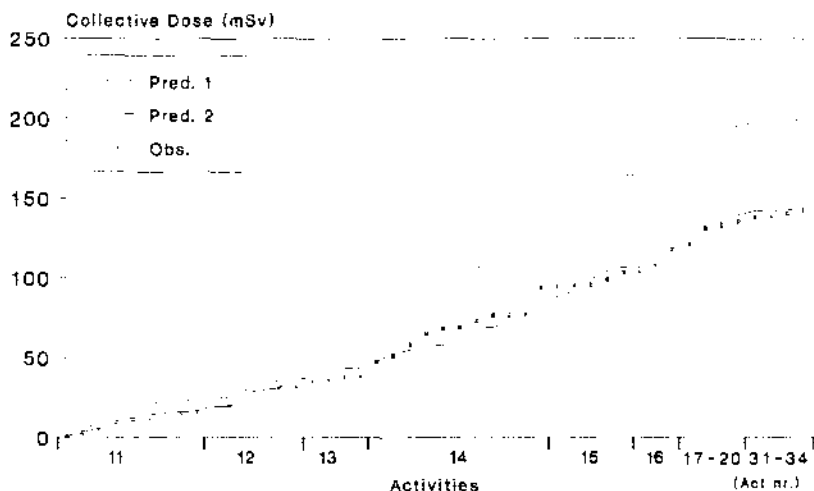

Fig. 2. Comparison of observed and predicted collective dose equivalents.

LEGEND : ACTIVITIES

- 11 Preparation of the working place
- 12 Replacement of seals
- 13 Closing of the reactor vessel
- 14 Placing and tightening of the bolts
- 15 Checking of the circuits
- 16 Modifications of the circuits
- 17 Filling and venting of the circuits.
- 18+19 Measuring dose rates
- 20 Hot run test
- 31-34 Execution of the decontamination

DEMANTELEMENT DE CHINON A2

M. CAMPANI - G. BETSCH - F. MUNOZ

ELECTRICITE DE FRANCE
SERVICE DE LA PRODUCTION THERMIQUE
PARIS - LA DEFENSE

CHINON A2 DISMANTLING

Application of the principles retained by EDF for its global decommissioning strategy resulted in the achievement of an IAEA-level 2 on the Chinon A2 installation.

This decision has been taken after the analysis of the safety parameters, radiological characteristics of the installation, in function of the techno-economic consequences of the radioactive waste management and the conditions of radioprotection.

Containment and in-situ intermediate storage of the own wastes of the installation were the main operations carried out. The global dosimetric cost is estimated at roughly 2.1 man-SV.

INTRODUCTION

La centrale de CHINON A2 fait partie du site nucléaire de CHINON, situé sur la rive gauche de la Loire et qui comprend deux types d'installations :

- 3 tranches (A1, A2 et A3) de la filière à uranium naturel, graphite-gaz (UNGG) respectivement mises en service en 1963, 1965 et 1966 et arrêtées en 1973, 1985 et 1990.
- 4 tranches (B1 à B4) de la filière à eau pressurisée (REP) respectivement mises en service en 1982, 1983, 1986 et 1987.

1 - CARACTERISTIQUES DE L'INSTALLATION

La tranche de CHINON A2 dont le circuit de refroidissement (4 boucles distinctes) est situé à l'extérieur du caisson du réacteur appartient à la première génération de centrales de la filière UNGG. D'une puissance électrique de 210 MW, elle a été couplée au réseau national en 1965 et a été arrêtée en juin 1985 après 132 000 heures de fonctionnement soit une disponibilité moyenne d'environ 70 % (86 % pour les cinq dernières années) et une production de 23,6 milliards de Kwh correspondant à l'utilisation de plus de 133 000 éléments combustibles.

Le combustible a été déchargé entre septembre 1985 et mai 1986 et son évacuation vers le Centre de Retraitement de MARCOULE s'est déroulée de janvier 1986 à avril 1987.

2 - BILANS MATIERE ET RADIOLOGIQUE

Le rayonnement gamma à l'intérieur du caisson est actuellement de l'ordre de 4 Gy/h et est essentiellement dû au Co 60.

Le tableau ci-dessous mentionne la masse et l'activité calculée au 1.1.1988 des principaux composants.

	Nature du composant	Masse (t)	Activité (GBq)
Coeur	Caisson	980	2000.10^3
	Structures internes	1490	14700.10^3
	Empilement graphite	1730	210.10^3
Hors Coeur	Echangeurs de chaleur	2760	1500
	Circuit primaire et soufflantes	855	115
	Circuits annexes	370	155

On peut relever un facteur 10^3 à 10^4 entre l'activité due à l'activation des composants internes du coeur et celle due à la contamination exclusivement sur leurs faces intérieures des composants situés à l'extérieur du réacteur.

L'activité massique la plus élevée est rencontrée sur les circuits de détection de rupture de gaine (1640 Bq/g). Le niveau de contamination surfacique des circuits est situé entre 1500 et 4000 Bq/cm². L'aspect radiologique caractérisant les éléments de circuits extérieurs au coeur, révèle un spectre de radio-éléments peu contraignant car les incidents sur le combustible sont restés rares, de faible importance et rapidement détectés et qui se traduit par l'absence d'émetteur alpha ; le spectre type déterminé à la date de l'arrêt de l'installation est le suivant :

Co 60 : 94,5 %
Mn 54 : 5,5 %
Cs 137 : quelques traces sur quelques prélèvements

3 - STRATEGIE DE DÉCLASSEMENT RETENUE

Conformément à la politique générale d'Electricité de France en matière de déclasserment des installations nucléaires, il a été décidé, sur la base d'études technico-économiques, prenant en compte en particulier l'état radiologique et physique de l'installation, de réaliser un déclasserment de niveau 2 AIEA suivi d'une période d'attente avant démantèlement total de quelques dizaines d'années. Pour parvenir à cet état intermédiaire, il a été nécessaire de réaliser les travaux suivants :

- isolement et confinement du réacteur avec obturation des traversées au plus près du caisson,
- confinement des 4 échangeurs de chaleur non démontés dans leurs locaux,
- démantèlement des circuits annexes,
- découpe du circuit primaire en tronçons de 1,4 m de longueur,

- conditionnement des circuits annexes dans les tronçons du circuit primaire ainsi obtenus, obturés aux deux extrémités et entreposés dans les quatre locaux des échangeurs,
- assainissement des locaux ayant comportés des circuits démantelés,
- maintien en dépression du réacteur et des échangeurs permettant ainsi un contrôle de l'intégrité du confinement.

Il est à souligner que l'entreposage intermédiaire in-situ des déchets métalliques, volumineux et peu actifs a été préféré au stockage définitif sur un centre agréé toujours très coûteux.

4 - DISPOSITIONS PARTICULIERES ADOPTEES POUR LES TRAVAUX

Les techniques mises en oeuvre dans les travaux de démantèlement étant tout à fait classiques, et n'ayant recours ni à l'utilisation de robots, ni à la téléopération, il a été nécessaire, afin de limiter la dosimétrie du personnel et d'éviter la sortie de zone contrôlée de tout élément radiologiquement non sain, de mettre en oeuvre certaines dispositions particulières suivantes :

- établissement de cartographies précises des débits d'exposition dans les locaux d'intervention,
- création d'une entrée-sortie de zone contrôlée unique pour les personnels et d'une sortie unique avec contrôle obligatoire pour les matériels supposés inactifs,
- adoption d'un système dosimétrique individuelle automatique complémentaire au film dosimétrique réglementaire et permettant d'affecter les doses par nature de travaux,
- installation dans la zone contrôlée d'un atelier de décontamination équipé d'un nettoyeur haute pression pour les pièces susceptibles d'être décontaminées et d'un atelier de traitement des matériaux pour la fabrication des colis de démantèlement,
- création dans la zone contrôlée de diverses zones délimitées et protégées d'entreposage temporaire de produits particuliers en attente de traitement.

5 - BILAN DOSIMETRIQUE

Les travaux de post-exploitation et de confinement menés depuis 1986 jusqu'à fin août 1991 par un effectif de l'ordre de 50 personnes (20 agents EDF - 30 agents d'entreprises) ont abouti à un total en dose intégrée de 1,94 h.Sv. Compte-tenu des travaux restant à effectuer, le niveau 2 devrait conduire à une dose intégrée globale d'environ 2,1 h.Sv.

Le diagramme ci-dessous illustre ce bilan et la répartition des doses en fonction des principaux chantiers effectués (exprimées en h.Sv).

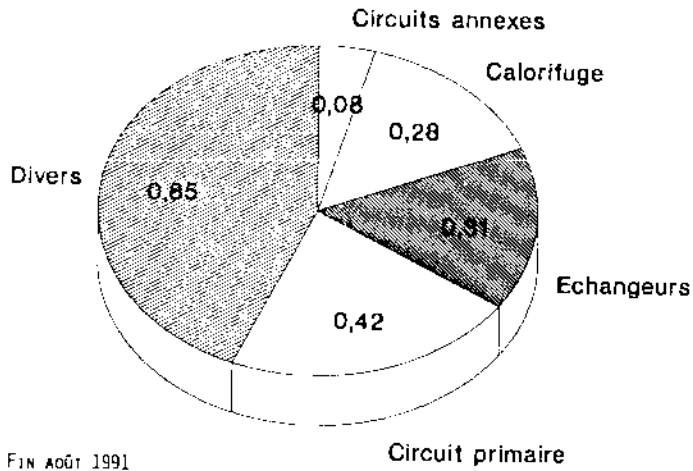

On note que ces doses ont été supportées à 14 % (0,28 Sv) par le personnel EDF et 86 % (1,66 Sv) par les entreprises extérieures intervenantes. Par ailleurs, la dose prise par le personnel EDF, essentiellement affecté à des tâches très diversifiées dans l'installation représente près du tiers de celle de la rubrique "divers" et est tout à fait insignifiante dans les autres chantiers.

6 - CONCLUSION

Le déclassement au niveau 2 de l'installation CHINON A2 tel que défini par l'exploitant a conduit à des travaux de démantèlement importants liés à l'architecture de la tranche et qui ont pu être réalisés à un coût dosimétrique tout à fait acceptable grâce à :

- des choix de solution simples facilités par la parfaite connaissance des installations par le personnel chargé des études et des travaux,
- une organisation rigoureuse et une préparation des travaux dans l'esprit des travaux de maintenance habituels (assurance de la qualité, procédures de consignation et de travail, radioprotection, etc.),
- des données radiologiques de l'installation relativement peu contraignantes comparativement au niveau de la contamination rencontrée dans les réacteurs REP.

Radiological Hazards from Deposits of Tin-Smelting Slag and the Problems of Site Clearance and Disposal

J C Gilmore and R G Jackson
SRD
AEA Technology
Wigshaw Lane, Culcheth,
Warrington, Cheshire, WA3 4NE
ENGLAND

ABSTRACT

High background dose rates from tin smelting slag used as sea defences led to the identification of our client's site as one of a number with a potential external and airborne radiological hazard. Surveys showed that access to the affected area should be restricted as a precaution. Samples taken for analysis fell just below the level of activity which would require the material to be disposed of as radioactive waste. To ensure safe disposal a scheme is being developed to dilute the slag with general building rubble before disposal to an appropriate landfill tip.

INTRODUCTION

From the end of the nineteenth century until the early 1970's tin smelting was carried out in Bootle and surrounding areas near Liverpool and the river Mersey in the UK. The tin bearing ore contains significant quantities of the naturally occurring radioactive isotopes ^{238}U and ^{232}Th and their daughters. The specific activity is enhanced in the slag during the smelting process and in large quantities the slag can present a significant radiation hazard.

The collapse of the industry in a depressed area of the country means that the problem arises on derelict or semi-derelict land. In addition the owners of the land are often not familiar with radiation protection legislation and its implementation.

This paper describes the provision of advice and assistance in radiation protection to the owners of a trading estate part of which had once been part of a tin smelting works. Operations included advice on immediate protection measures, identifying and contacting the relevant authorities and the arrangements for clearing the site and disposing of the material.

DISCOVERY OF PROBLEM

The first indication of the existence of a radiological hazard came during a routine survey being carried out for Sefton Metropolitan Borough Council. Radiation levels over 10 times the normal background were traced to rocks in the river estuary put in place as part of sea defences. The rocks turned out to be made up of waste slag taken from local smelting works.

An assessment of the hazard to members of the public using the area concluded that the critical group were likely to be dog owners out exercising their animals (the area is away from

beaches which are likely to be frequented during the summer). It was estimated that an individual would need to be exposed for 70 hours for doses to exceed 500 μSv which was thought to be considerably more than would occur annually. The council therefore decided that no further action was required with respect to the sea defences.

However, Her Majesty's Inspectorate of Pollution (HMIP), which is responsible, *inter alia*, for administration of the Radioactive Substances Act (ref 1), were informed. HMIP compiled a list of sites where a hazard may exist and notified the owners. Following a visit to an industrial estate, part of which had once been part of a tin smelting works, the owners of the site asked us for advice on immediate precautions which were likely to be necessary and long term measures to remove the problem.

NATURE OF THE HAZARD

The tin bearing ore contains ^{238}U and ^{232}Th and their daughters. The thorium decay series includes ^{208}Tl with a 2.6 MeV gamma emission. This means that although the specific activity is low large quantities can exhibit significant external dose rates because of the build up of radiation from within the bulk material. Each decay chain includes an isotope of radon gas which could result in significant radiation doses if it diffused into buildings constructed over the slag without proper precautions.

From the point of view of the site owners the problem is therefore one of controlling the hazard from external radiation before any development takes place and taking steps to control the additional hazard from airborne activity in any buildings on the site. One such site in the area had been developed for housing and all the slag had had to be removed before building could commence to ensure that there would be no abnormal radon hazard.

In formulating a proposal for the disposal of the smelting slag a major consideration must be that the problem is not simply transferred to another site.

SURVEY RESULTS

The survey of the site carried out by HMIP had shown areas with dose rates up to 6.5 $\mu\text{Sv h}^{-1}$. While this is not particularly high in a nuclear establishment it is high for an area where there are no restrictions on access. An initial survey at the start of the contract confirmed the results and further defined the high dose rate areas as being associated with a particular type of material and a sample was taken for analysis.

A more detailed survey was carried out during which a number of samples of various types of material were taken for analysis from different depths with the aid of a mini-excavator. In areas previously inaccessible due to brambles dose rates up to 10 $\mu\text{Sv h}^{-1}$ existed at 1m above the surface. A plan of the site with associated dose rates is shown in fig 1.

Table 1 shows some results of the samples taken from the locations shown in fig 1. Only representative nuclides below and above the radon isotopes need be measured equilibrium levels soon become established after the processing. Values in brackets have been inferred from other measurements; samples were analysed by different laboratories but there was good agreement between them. The slag (samples 2, 3, B(2) and C(2)) is hard vitreous material but around 30% of the ^{220}Rn is lost before it decays to ^{216}Po and around 60% of ^{222}Rn diffuses out.

It was found that the area was covered with slag and rubble to a depth of approximately 1.5m. About 1000m² was found to consist of the more active 'black slag' with about 2500m² of less active 'grey slag' weighing approximately 1900 and 3200 tonnes respectively. The remainder of the material is building rubble.

The total activity has been estimated to be 11.3 GBq ^{238}U and 26.9 GBq ^{232}Th .

REMEDIAL MEASURES

Following the initial site visit and discussions with the Factory Inspector from the Health and Safety Executive (HSE) the owners were advised to fence off the affected area. Strictly speaking as no operations were being carried out in the area it does not come within the category of work with ionising radiations but it was considered prudent to restrict access.

Normally before radioactive waste may be accumulated the operator must register under the Radioactive Substances Act. However, as the activity is naturally occurring an exemption order under the act (ref 2) applies and registration is not required. Similarly a licence is normally needed for the disposal of radioactive material with a specific activity exceeding very low limits (e.g. Thorium: 2.6 Bq m⁻³). The exemption order allows disposal of waste containing natural activity up to 15 Bq m⁻³.

As can be seen from Table 1 the levels of activity just fall below the limit and could therefore be disposed of without reference to HMIP. However, this would only transfer the problem from one location to another and it could resurface at a later date. The solution which has been proposed is to 'dilute' the active material with general building rubble. This has been used successfully on waste from other sites in the locality. In the current recession the site owner has no plans at present to develop the affected area and currently only requires a disposal route to be identified and an outline of arrangements to ensure the protection of workers during removal operations. These will be prepared in the near future in consultation with HMIP and the HSE and put on hold until such time as they are required.

REFERENCES

1. Radioactive Substances Act 1960 As Amended 1990
2. The Radioactive Substances (Phosphatic Substances, Rare Earths etc.) Exemption Order 1962

TABLE 1: Analysis Results

Nuclide	Sample Activity (Bq/g)					
	1	2	3	F	B 2	C 2
Th-232	(2.5)	(12.1)	(14.2)	0.09	12.1	14.7
Po-216	(2.5)	(8.7)	(10.2)	(0.07)	(8.7)	(10.6)
Tl-208	0.9	(2.9)	(3.4)	(0.02)	(2.9)	(3.5)
U-238	(1.6)	(5.3)	(6.2)	0.24	5.0	5.4
Po-218	(1.8)	(1.8)	(2.1)	(0.07)	(1.6)	(1.7)

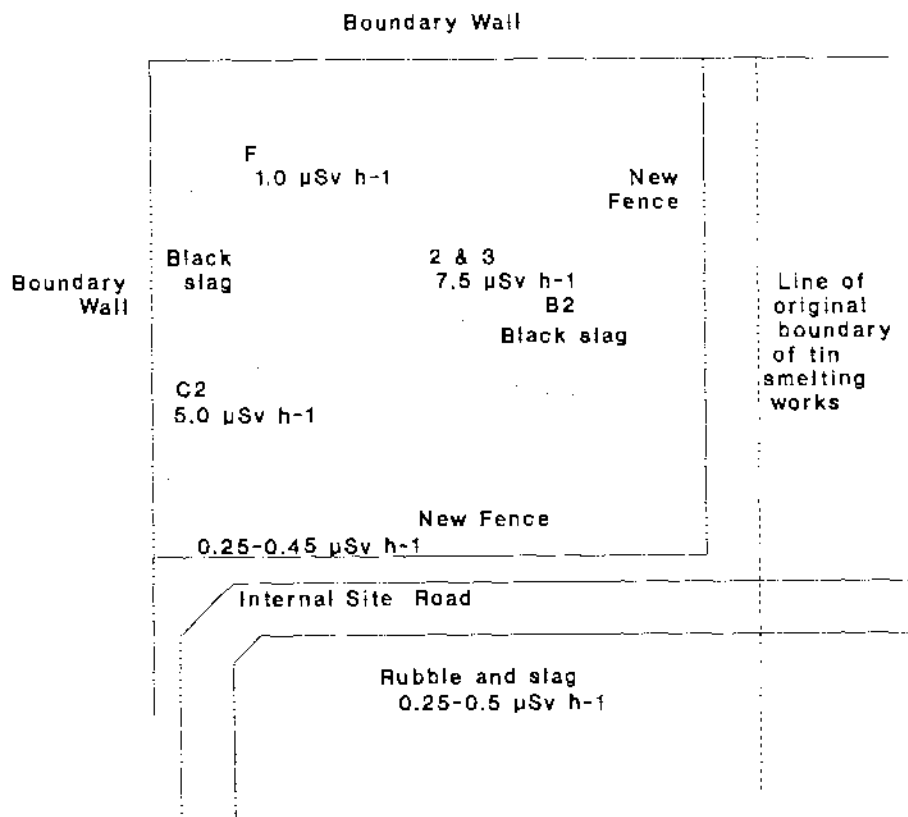

Figure 1: Plan of Affected Area

Radiation Control Experience during JPDR Decommissioning

J. ONODERA, C. NAKAMURA, H. YABUTA, Y. YOKOSUKA,
T. NISIZONO and Y. IKEZAWA

Japan Atomic Energy Research Institute
Tokai-mura, Naka-gun, Ibaraki-ken, 319-11, JAPAN

ABSTRACT

The JPDR decommissioning program was begun in 1986, by the end of March 1991 most of activated and contaminated equipments were removed. The cumulative collective dose equivalent since initiation of the program is about 0.28 man-Sv. Dose distribution of workers engaged in dismantling of the reactor internals and the RPV showed hybrid log-normal distribution. Radioactive aerosol generation with mechanical cutting tools was higher than that with thermal cutting tools.

INTRODUCTION

Japan Power Demonstration Reactor (JPDR) is a BWR-type experimental power plant (12.5MWe) that begun to generate electricity for the first time in Japan in 1963. The plant was shut down permanently in 1976. The JPDR decommissioning program was begun in 1986. By the end of March 1991, reactor internals and a reactor pressure vessel (RPV) were dismantled using an underwater plasma arc cutting system and an underwater arc saw cutting system, respectively, in order to reduce exposure to workers and aerosol generation. This report describes radiation control experience during the decommissioning.

EXTERNAL EXPOSURE CONTROL

During the dismantling work, dose reduction measures for workers were taken, such as remote dismantling techniques, installation of shield. The cumulative collective dose equivalent since initiation of the JPDR decommissioning program is about 0.28 man-Sv. The collective dose equivalent for the removal of the reactor internals and the RPV was 0.073 man-Sv and 0.11 man-Sv, respectively. Figure 1 shows management data of JPDR decommissioning. Most of the exposure resulted from the removal of dross in fuel pool produced by underwater plasma arc cutting and the installation of a water tank which allowed the RPV to be submerged in water when it was cut.

Dose distribution models of workers are important in evaluation of collective dose in the planing stage. The distributions of cumulative dose of workers who engaged in the dismantling of the reactor internals and the RPV showed hybrid log-normal distribution¹. Figure 2 shows hybrid log-normal plots

This work performed by the JAERI under contract from the Science and Technology Agency Japan.

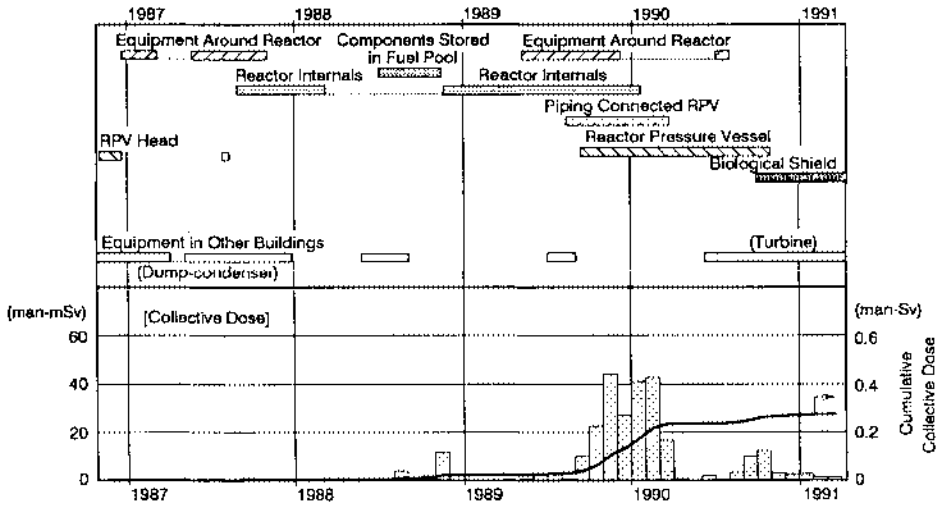

Figure 1 Management data of the JPDR decommissioning

of cumulative doses of the two groups. These dismantling work continued more than one fiscal year during which individual dose was restricted below the dose limit. The scattering of cumulative dose of the several workers who received the highest dose in FY 1989 decreased compared with that of total period of dismantling. This implied the effort of dose reduction and leveling off the dose of the workers to prevent the dose of small part of the worker becoming much higher compared with others.

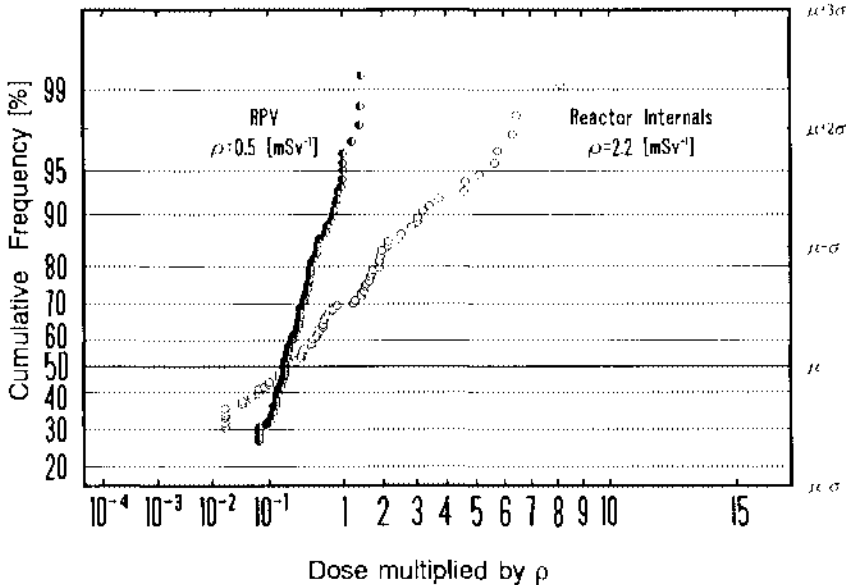

Figure 2 HLN probability plots of cumulative dose of workers engaged in removal of the reactor internals and the RPV

Various newly developed dismantling methods were adopted in the decommissioning to demonstrate their technical feasibility. In the dismantling of the forced recirculation outlet pipe connected to the RPV and penetrated biological shield, rotary disk knife cutting technique which could cut the pipe from outside of the biological shield remotely was adopted². Surface concentration of radioactivity inside the pipe was 1000 Bq/cm² and dose rate around the RPV where the pipes were connected was a few hundred μ Sv/h. Table 2 shows the man-power and collective dose equivalent for the dismantling of the forced recirculation pipes with the rotary disk knife and an oxy-acetylene torch. Total man-power of the rotary disk knife cutting was 3 times higher than that of the oxy-acetylene torch and 75% of the man-power was due to installation of the cutting equipment. Collective dose equivalent in the rotary disk knife cutting was very low compared with the oxy-acetylene torch, because the workers didn't need to access the RPV to cut the pipe. 40% of collective dose equivalent of the oxy-acetylene torch was due to installation of shield around the RPV.

Table 1 Total manpower and collective dose equivalent for dismantling of forced circulation pipes

Method	Object	Man-Power (man-day)	Collective dose equivalent (man-mSv)
Rotary disk knife	outlet pipe	354	0.2
Oxy-acetylene torch	inlet & outlet pipes	110	11.5

INTERNAL EXPOSURE CONTROL

To prevent the spread of air contamination, temporary containment enclosures equipped with ventilation system were built and it was possible to reduce effectively the radioactivity concentration in air of working places. During the dismantling work, to select the most suitable measures for reduction of internal exposure, the radioactive concentration in air of working areas must be evaluated in advance. But little data is available for radioactive aerosols from dismantling work for quantitative evaluation^{3,4}. Based on the measured aerosol radioactive concentration or mass concentration, normalized aerosol generation ratios, termed as immigration ratios (defined as : radioactivity in aerosols generated / radioactivity in kerf, and mass of aerosol generated / mass of kerf), were evaluated which will be used for evaluation of radioactive concentration or mass concentration in air during dismantling work.

Table 2 shows the immigration ratio for the radioactively contaminated stainless steel pipes segmentation with various

Table 2 Immigration ratios for stainless steel pipe segmentation

Cutting tool	Pipe size (inch)	Radioactivity immigration ratio (%)		Mass immigration ratio (%)	
		Range	Mean	Range	Mean
Band saw	2	5.8 - 37	13	---	$< 10^{-2}$
Band saw	6	10 - 58	19	---	$< 10^{-2}$
Reciprocating saw	12	7.0 - 24	9.9	---	$< 10^{-2}$
Plasma torch	12	0.23 - 0.78	0.44	0.53 - 0.82	0.66

cutting tools⁵. Because of the high radioactivity immigration ratio of the reciprocating saw, the radioactivity in aerosol generated per cut of the 12-inch pipe was about 30 times greater than that with the plasma torch. The size distribution with the plasma torch contained higher ratio of sub-micron aerosols than that with the reciprocating saw and showed bimodal distribution. The immigration ratios ranged from the order of $10^{-3}\%$ to $10^{-2}\%$ for underwater plasma arc cutting of the reactor internals and underwater arc saw cutting of the RPV.

During the reactor internals segmentation, besides the temporary containment enclosure, an air curtain was installed over the water surface of the pool to further enclose radioactive aerosols. Supply air flow rate was 40 m³/min and exhaust air flow rate was 140 m³/min. The ratio of the radioactive concentration of the lower side of the air stream to the upper side during the internals cutting ranged from 10 to 1000 and average ratio was 45.

REFERENCES

1. Kumazawa, S and T.Numakunai (1981). A new theoretical analysis of occupational dose distributions indicating the effect of dose limits. *Health Phys.*, 41, 465-475.
2. Yanagihara, S. F.Hiraga and H.Nakamura (1989) Dismantling techniques for reactor steel piping. *Nucl. Tech.* 86, 159-167.
3. Newton, G.J., M.D.Hoover, E.B. Barr, B.A. Wong and P.D. Ritter (1987). Collection and characterization of aerosols from metal cutting techniques typically used in decommissioning nuclear facilities. *Am. Ind. Hyg. Assoc. J.*, 48, 922-932.
4. Stang, W. and N.Eickelpasch (1990). Decommissioning of Gundremmingen Unit A. Proceedings of the Jt. ASME/IEEE Power Generation Conference, Boston.
5. Onodera, J., H.Yabuta, T.Nisizono, C.Nakamura and Y.Ikezawa (1991). Characterization of Aerosols from Dismantling Work of Experimental Nuclear Power Reactor Decommissioning. Proceedings of the European Aerosol Conference, Karlsruhe. to be published as a special issue of *J. Aerosol Sci.*

LA REGLEMENTATION FRANCAISE EN MATIERE DE LIMITATION DES RISQUES RADIOLOGIQUES DES SITES MINIERES URANIFERES

par J. PRADEL, ingénieur conseil
27, rue Chanez - 75016 PARIS
(document préparé avec P. ZETTWOOD, CERTAC, CEN/FAR
92265 FONTENAY-aux-ROSES CEDEX, France)

RESUME

Marked anomalies in uranium concentration of the geological medium characterize regional natural radioactivity, which is significantly altered by mining and milling of uranium ore and the resulting generation of solid wastes. In consequence, additional exposure to ionising radiation may occur via various potential transfert pathways. A system for limitation of the associated radiological risks has been applied in France for more than 20 years, and formed the basis of French regulations adopted in March 1990. These regulations specify the conditions to be applied in monitoring of mining sites. In addition, they detail the management restrictions required to ensure that the limits of individual cumulated exposure of the population are not exceeded and that the radiological impact is minimised.

INTRODUCTION

Les opérations d'extraction et de traitement de minerais perturbent toujours de façon plus ou moins importante les sites concernés. Le milieu géologique est modifié par rapport à son état initial et des dépôts de produits solides provenant de l'extraction ou du traitement des minerais sont créés en surface. Il en résulte, dans le cas des mines d'uranium, une modification des niveaux de radioactivité naturelle et de l'exposition correspondante.

Les nuisances liées à l'extraction et au traitement des minerais d'uranium :

Les travaux miniers provoquent une déstabilisation du milieu géologique initial perturbant le comportement mécanique des formations géologiques, l'hydrogéologie locale et la géochimie des eaux de percolation.

L'exploitation entraîne aussi la création en surface de dépôts de déchets solides d'extraction constitués par les roches encaissantes qu'il faut extraire pour accéder au minerai et par les résidus du traitement destiné à obtenir les concentrés uranifères.

Des envois de poussières et des transferts de matières solides peuvent se produire à partir de ces dépôts ou des anciens travaux. Des transferts d'éléments solubles lixivifiés et des dégagements de radon 222 provenant du radium 226 peuvent aussi avoir lieu surtout dans le cas des résidus de traitement. Il faut aussi prendre en considération deux nuisances à caractère aléatoire : le risque d'instabilité des dépôts et le risque d'intrusion humaine avec construction d'habitation sur le dépôt ou utilisation des déchets comme matériaux de construction. A l'ensemble de ces nuisances potentielles, il faut aussi ajouter celle due au fait même de l'existence de tels dépôts avec les contraintes associées quant à l'utilisation ultérieure des emplacements correspondants.

La protection contre les nuisances potentielles

Il existe heureusement des technologies efficaces pour maîtriser ces nuisances potentielles. Elles reposent sur la mise en place de barrières de confinement comprenant notamment :

- des barrières d'étanchéité vis-à-vis des eaux de percolation, constituées de préférence d'une couche épaisse de matériaux géologiques naturels placée dans le soubassement du stockage,
- une couverture de surface pour limiter à la fois le débit de dose gamma en surface, les dégagements de radon, les infiltrations d'eau, les entrées d'oxygène dans le cas de minerais contenant de la pyrite, la pénétration des animaux et les intrusions humaines.

Il est ensuite possible de procéder à une réhabilitation du territoire, adaptée à chaque cas, qui peut comprendre un remodelage des formes paysagères, une modification du tracé des cours d'eau et une remise en végétation appropriée.

L'état des connaissances sur les mécanismes fondamentaux régissant les transferts vers l'homme des radionucléides présents sur les sites miniers ainsi que l'expérience acquise in situ dans de nombreux pays depuis deux ou trois décennies, permettent d'atteindre les objectifs actuels de limitation de l'exposition des populations avoisinantes tels qu'ils sont précisés dans la réglementation nationale française actuelle.

Les bases de la réglementation

La réglementation est nécessairement spécifique des déchets miniers contenant des radionucléides naturels de la durée de l'uranium pour les raisons suivantes :

- Les radionucléides principaux concernés sont l'uranium naturel, le thorium 230 et le radium 226. Ils ont tous des périodes extrêmement longues : $4,510^9$ ans pour l'uranium et $7,7.10^4$ ans pour le thorium 230. Quant au radium 226, sa période est de 1600 ans, mais sa décroissance est régie par le thorium 230 lorsqu'il lui est associé dans les résidus de traitement. Aussi, à la différence des stockages de surface des déchets de faible activité provenant des réacteurs nucléaires, la banalisation des sites au bout de 3 ou 4 siècles ne peut pas se justifier puisqu'il n'y a pas décroissance de l'activité. En effet, en vertu du principe qui veut que l'on admette pour l'exposition des générations futures, même très éloignées, les limitations actuelles, toute banalisation ne peut dans ce cas, être qu'immédiate. Il doit donc être instauré des contraintes illimitées dans le temps, ce qui amène à utiliser des ouvrages de stabilisation dont l'entretien et la surveillance soient relativement aisés et ne constituent pas des charges inacceptables pour les générations futures.

- Il s'agit de radionucléides naturels dont les activités spécifiques sont dans le stockage de l'ordre de cent fois celles rencontrées dans l'environnement non perturbé. Dans le cas des déchets contenant des radionucléides artificiels, l'absence de bruit de fond naturel à un niveau facilement mesurable rend la détection de ces radionucléides possible à très longue distance des points d'émission, voire à l'échelle planétaire, alors que l'on ne peut observer le marquage radioactif d'un stockage de déchets miniers qu'à de faibles distances, de l'ordre du kilomètre. Il en résulte qu'en raison des fluctuations temporaires et spatiales du bruit de fond naturel, l'impact des installations minières ne peut être correctement évalué qu'après plusieurs années d'observation avec un réseau de stations de mesure fonctionnant en continu.

- Les populations dans ces régions subissent des expositions naturelles, non liées à l'exploitation, dues au rayonnement alpha, au radon domestique et aux eaux radifères d'origine locale souvent très supérieures aux valeurs exigées pour les centres de stockage de surface des déchets radioactifs artificiels. Il en résulte que pour que la mesure de l'impact radioactif soit possible

au milieu du bruit de fond d'origine naturelle, et pour que les contraintes liées au respect des limites imposées pour cet impact soient justifiées, on ne peut pas raisonnablement exiger que la valeur tolérée pour l'exposition ajoutée soit tout-à-fait négligeable par rapport aux valeurs de bruit de fond et de ses fluctuations locales et temporaires.

- Les scénarios d'intrusion humaine dans les stockages conduisent par contre à des expositions qui dépassent celles considérées comme acceptables. Ces expositions ne peuvent être évitées, comme d'ailleurs des exposition identiques sur de nombreux sites uranifères non exploités, que grâce à l'établissement de servitudes liées au site et réglementant certaines pratiques.

La réglementation française :

L'ensemble de ces considérations a été pris en compte pour l'élaboration de la réglementation française de 1990 pour les sites miniers, dont on peut retenir les points suivants :

- fixation d'une limite inférieure pour les déchets solides devant faire l'objet d'un plan de gestion : teneur en U = 0,03%.
- fourniture d'une étude d'impact préalable
- limitation de l'exposition individuelle ajoutée à 5 mSv/an avec pour l'énergie alpha potentielle pour les descendants du radon 222, la correspondance 5 mSv → 2 mJ,
- fixation de limites en radium 226 pour les rejets liquides :
 - . Concentration inférieure à 740 Bq/m³ : rejet sans condition
 - . Concentration inférieure à 740 et supérieur à 3 700 Bq/m³ avec facteur de dilution du rejet pour les cours d'eau supérieur à 5 : rejet sans condition.
 - . Dans les autres cas, mise en place d'une station de traitement qui doit abaisser la concentration en dessous de 370 Bq/m³, en application du principe d'optimisation.
- Calcul de l'exposition ajoutée des groupes critiques déterminée pour chaque phase d'exploitation ou d'aménagement, à partir de mesures de l'activité d'échantillons d'eau et d'aliments divers et aussi grâce aux résultats fournis par un réseau de surveillance à base de stations fixes judicieusement implantées et comprenant un dosimètre TL pour la mesure de l'exposition alpha, un dosimètre de site pour la mesure de l'énergie potentielle alpha (comprenant un filtre de prélèvement, un collimateur sélecteur de particules à 4 plages d'énergie, un film de nitrate de cellulose où sont comptées les traces de particules alpha de différentes énergies), un dispositif de prélèvement de poussières permettant la mesure en laboratoire de leur activité alpha à vie longue.

Application de la CIPR 60

La publication 60 et la CIPR ne modifient pas les recommandations antérieures pour la gestion du risque radon qui est la source principale d'exposition dans le cas des sites miniers. Mais il est certain qu'un abaissement important des limites concernant le radon et ses descendants poserait des problèmes difficiles de différentes natures :

- difficultés pour mesurer les niveaux des expositions apportées compte tenu des incertitudes quant à l'origine du radon et apparition de problèmes juridiques associés,

- incohérence évidente entre les exigences pour limiter le radon provenant des travaux miniers et des dépôts de résidus associés, à des concentrations très inférieures à celles du radon préexistant localement. Cette incohérence est illustrée par les données suivantes :

- . bruit de fond radon sous forme gaz dans l'atmosphère libre : 1 à 30 Bq/m³, pouvant atteindre quelques centaines de Bq/m³ dans les régions uranifères et situations de ventilation atmosphériques défavorables,
- . recommandation CIPR pour le radon sous forme gaz dans les habitations : 200 ou 800 Bq/m³,
- . limitation pour la contribution des sites miniers (radon sous forme gaz avec un facteur d'équilibre des descendants de 0,5) :
 - 30 Bq/m³ si la limite d'exposition est fixée à 1 mSv/an
 - 3 Bq/m³ si la limite d'exposition est fixée à 0,1 mSv pour tenir compte des autres pratiques donnant lieu à l'exposition des groupes critiques.

CONCLUSIONS

L'environnement des installations minières et des usines de traitement de minerai est obligatoirement perturbé, ce qui ne constitue pas une affirmation nouvelle puisqu'à l'époque d'Agricola dans les années 1550, les détracteurs des activités minières, ancêtre des Ecologistes modernes, affirmaient que les exploitations minières causent plus de détriments qu'elles ne procurent de bénéfices. Mais dans le cas des minerais d'uranium, la connaissance des modalités d'exposition des populations et les performances des techniques de confinement permettent de limiter les expositions des populations concernées à des valeurs tout-à-fait acceptables, voire inférieures à ce qu'elles étaient avant exploitation. Des réglementations conformes aux recommandations de la CIPR peuvent être établies et l'ont été récemment en France en 1990. Les objectifs définis par ces réglementations pour assainir les sites miniers sont accessibles dès maintenant et pourraient être maintenus sans limitation dans le temps à condition que des servitudes restent attachées aux sites de façon permanente. Ces servitudes sont acceptables et ne correspondent qu'à ce qu'il conviendrait en toute logique, d'imposer aux nombreuses régions présentant des anomalies naturelles de concentration en uranium et probablement à de nombreuses mines considérées comme non uranifères. La CIPR qui doit traiter de la gestion du risque radon doit prendre en compte les problèmes qui risquent de se poser pour maintenir la cohérence entre les différentes recommandations tout en conservant l'ensemble de son système de gestion de risques.

REFERENCES

- [1] LOUBOUTIN C. "Au néolithique". Découvertes Gallimard (F), n° 90, 1990
- [2] AGRICOLA G. "De re metallica", 1556, Traduction française de A.F. Lanord, Edition G. Klopp, 1987
- [3] Principes de surveillance de la protection radiologique de la population. Publication CIPR N° 43
- [4] Current practices and options for confinement of uranium mill tailings. Technical Report Series n° 209, IAEA, 1984
- [5] Aspects radiologiques à long terme de la gestion des déchets résultant de l'extraction et du traitement de l'uranium. AIEA, 1984

TRAITEMENT PAR FUSION
DES DECHETS METALLIQUES FAIBLEMENT CONTAMINES
PAR DES SUBSTANCES RADIOACTIVES

C. ANDRIEUX, C. DOUCET, J.C. LEBRUN,
Commissariat à l'Energie Atomique
Centre d'Etudes de Saclay
91 191 GIF sur YVETTE Cedex
FRANCE.

Fusion of metallic wastes slightly contaminated with
radioactive substances

The increasing of metal waste volume contaminated by radioactive substances coming from nuclear facilities, led the Commissariat à l'Energie Atomique (Research Center of Saclay) to study the possibilities brought by melting processing of such a type of waste.

This report describes both the realized facility and the remedies brought to the problem arising due to the presence of radioactive contaminants (filtering, operator protection, etc). It deals with the results obtained after processing of some 30 tons of metallic waste coming from the dismantling of the primary circuit of a research reactor laid out on Saclay's site, as well as the outlooks expected through the process.

1 - INTRODUCTION

Les mesures de la contamination résiduelle des déchets métalliques issus de démantèlement sont fastidieuses et entachées d'erreurs et ne permettent pas le plus souvent de répondre aux exigences des autorités de sûreté en matière d'évacuation des déchets.

A défaut de certitude la pratique courante conduit à surclasser ces déchets en les considérant comme justifiables d'un stockage en site spécialisé avec pour conséquence des coûts importants entraînés par leur conditionnement, leur transport et leur prise en charge.

Parmi les méthodes envisagées pour pallier ces inconvénients, le traitement par fusion est apparu de nature à répondre aux objectifs suivants :

- Réduction significative des volumes
- Décontamination partielle
- Caractérisation précise du lingot obtenu
- Répartition homogène et immobilisation dans la matrice de la contamination résiduelle
- Optimisation du conditionnement.

2 - DEFINITION DE L'INSTALLATION

2.1. Caractéristiques des déchets à fondre

Ce sont des tuyauteries, vannes, capacités en acier et en moindre quantité en alliages d'aluminium et de cuivre. Ils sont contaminés, à des degrés divers, par des radionucléides émetteurs bêta, gamma avec en faible quantité des émetteurs alpha. Ces déchets, aux formes multiples, ne sont pas exempts de matières organiques, (caoutchouc, matières plastiques, huile...) et de peinture. Enfin plusieurs métaux et alliages peuvent être associés.

2.2. Choix du four

Après étude comparative, le choix s'est porté, compte tenu des quantités à traiter, sur un four à induction (mise en oeuvre facile, brassage vigoureux du bain) d'une capacité de 700 kg d'acier, alimenté par un générateur délivrant 400 kW sous 800 volts à 1000 Hertz. Le creuset est réalisé en pisé alumineux (93,8% Al_2O_3 , 3% Cr_2O_3 , 3,2% autres liants), son diamètre utile est de 400 mm, sa hauteur de 1040 mm.

2.3. Implantation

Le four a été installé dans une cellule ventilée, maintenue en dépression par l'intermédiaire d'un circuit d'extraction et de filtration d'air raccordé à la cheminée de l'installation. Cette cellule (volume 200 m³) est desservie par deux sas, (accès personnel, accès matériel). Le four a été placé dans une fosse de rétention, en cas de vidange accidentelle.

2.4. Le circuit d'épuration des effluents gazeux

La figure 1 montre le dispositif mis en place à l'issue d'une étude effectuée en 1985 [1] Il se compose d'une hotte reliée à un préfiltre électrostatique lui-même relié à la cheminée par l'intermédiaire de filtres à très haute efficacité. L'étude entreprise a permis de déterminer le diamètre médian et les débits d'aérosols produits lors des fusions (diamètres : inférieurs au micron et débits compris entre 0,05 et 3 grammes par kilogramme de métal fondu).

Des essais comparatifs effectués sur des préfiltres [2], tels que électrocyclone, filtres à manches, filtres électrostatiques ont montré l'intérêt de ces derniers qui présentent un rendement de filtration voisin de 99% tout en ne produisant qu'une très faible quantité de déchets secondaires.

2.5. Protection des opérateurs

Les agents travaillant à proximité du four sont équipés de vêtements ventilés réalisés en tissu aluminisé à l'intérieur desquels est distribué l'air respirable qui est également utilisé pour le refroidissement du corps et pour assurer la surpression constituant l'étanchéité dynamique vis à vis de la contamination. Les opérateurs communiquent entre'eux et avec l'agent de surveillance par liaison phonique.

3 - DESCRIPTION SOMMAIRE DU PROCEDE

Les déchets métalliques sont placés sur le chantier de démantèlement dans des bacs métalliques. Avant chargement dans le four, ils sont découpés à l'aide d'une cisaille hydraulique, en fragments de 15 cm de côté.

Le remplissage initial du Creuset est complété au fur et à mesure de la fusion. Après ajustage de la température de coulée, on procède à l'ajout d'entraîneurs favorisant le décrassage du bain et la formation des laitiers. Après écrémage des scories surnageantes, la coulée est opérée par basculement du four, dans une lingotière.

3.1. Les prélèvements d'échantillons, les mesures de radioactivité

Six prélèvements sont effectués à chaque coulée : deux échantillons de métal, deux échantillons de scories, deux prélèvements de poussières et aérosols en amont et en aval du préfiltre électrostatique. Après mise en solution des échantillons, les caractéristiques radioactives sont déterminées par spectrométrie gamma et alpha, par comptage et par scintillation liquide.

4 - RESULTATS OBTENUS

A l'issue du traitement d'environ 30 tonnes de déchets métalliques issus du démantèlement du circuit primaire du réacteur de recherche EL3, on peut résumer comme suit les résultats obtenus :

- Facteur de réduction du volume au moins égal à 10, comparé au volume d'un colis de déchets standard
- Répartition très homogène de la contamination résiduelle dans le lingot due essentiellement au phénomène de brassage du bain
- Excellente caractérisation des lingots permettant d'optimiser leur destination finale
- Qualité exceptionnelle du conditionnement de la radioactivité résiduelle.
- Décontamination quasi totale pour le tritium (98%), importante (90%) pour le césium, par entraînement dans les scories, les fumées et aérosols.

5 - PERSPECTIVES OFFERTES PAR LE PROCÉDE

Cette installation, de taille modeste, est cependant bien adaptée au traitement des quelques 100 tonnes de déchets métalliques produits annuellement dans un centre de recherche tel que Saclay. Ce procédé permet de valoriser les métaux récupérés en envisageant pour les lingots de très faible activité résiduelle une réutilisation de la matière première soit en milieu nucléaire (fabrication d'écrans, de conteneurs à déchets...) soit en milieu industriel surveillé, voire leur banalisation lorsque la radioactivité résiduelle se situe au niveau des traces. Il permet par voie de conséquences d'éviter l'engorgement des sites de stockage par "des pseudo-déchets". Son application est facilement extrapolable à des installations de tailles beaucoup plus importantes .

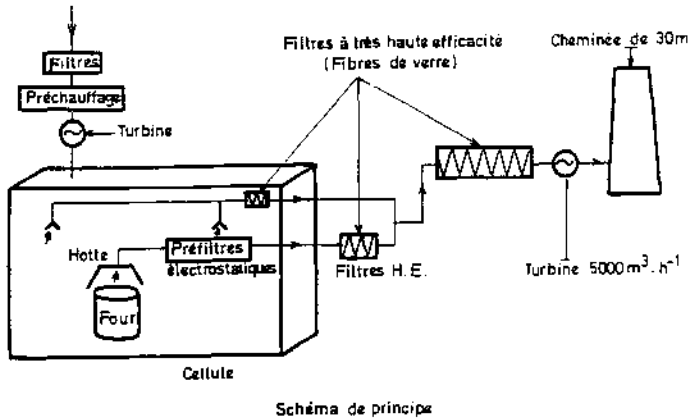

Figure 1

VENTILATION DE L'INSTALLATION DE FUSION DES MÉTAUX.

Bibliographie :

- [1] Filtration des effluents gazeux émis par un four de fusion de métaux contaminés
C. ANDRIEUX, F. DANIEL, J. VENDEL
Européan conférence on gaseous effluents treatment in nuclear installations - LUXEMBOURG 14, 18 octobre 1985.
- [2] Essais de préfiltration des effluents gazeux émis par un four à fusion de métaux - CEA -
IPSN/DPT/SPIN/SEIP/ARD 302 - Mai 1986

UTILISATION D'UN MELANGE TRIPHASIQUE PRESSURISE
GRAPHITE-EAU-OXYGENE EN INCINERATION
DIRECTE DE GRAPHITE IRRADIE

G. ANTONINI - UNIVERSITE DE COMPIEGNE - CENTRE DE
RECHERCHE DE ROYALLIEU - BP 233
60206 COMPIEGNE CEDEX

JP. PEROTIN . P. CHARLOT - Société des Techniques
en Milieu Ionisant - 9 rue Fernand Léger -
91190-GIF-sur-YVETTE

THE UTILIZATION OF A PRESSURIZED-GRAPHITE/WATER/OXYGEN
MIXTURE FOR IRRADIATED GRAPHITE INCINERATION

The authors demonstrate the interest of the utilization of a pressurized-graphite/water/oxygen mixture in the incineration of irradiated graphite. The aqueous phase comes in the form of a three-dimensional system that traps pressurized oxygen, the pulverulent solid being dispersed at the liquid/gas interfaces. These three-phasic formulations give the following advantages :

- reduction of the apparent viscosity of the mixture in comparison with a solid/liquid mixture at the same solid concentration;
- reduction of the solid/liquid interactions;
- self-pulverizability, thus promoting reduction of the flame length ;
- utilization of conventional burners;
- reduction of the flue gas flow rate ;
- complete thermal destruction of graphite.

INTRODUCTION

Dans le cadre du démantèlement de réacteurs nucléaires UNGG, les auteurs proposent un nouveau procédé visant la destruction complète du graphite irradié par incinération directe à haute température, d'un mélange triphasique graphite/eau/oxygène (PG-WOM pressurized/graphite/water/oxygène mixture).

Le transport en conduit de solides divisés en vue de l'alimentation d'enceintes de réaction est classiquement réalisé grâce à deux vecteurs :

- le transport pneumatique, par lequel le solide divisé est convoyé en conduite sous forme d'une dispersion gaz/solide pseudo-homogène, ou bien sous forme d'un lit mobile aux plus faibles vitesses;
- le transport dense en phase " slurry " dans lequel le solide divisé est convoyé en conduite sous forme d'une suspension solide/liquide se comportant comme un fluide pseudo-homogène visqueux.

Les auteurs ont choisi une troisième voie qui consiste à utiliser une solution intermédiaire, à savoir le transport du graphite divisé sous forme d'une dispersion gaz/solide/liquide. Le mélange triphasique en question consiste en une mousse chargée, pressurisée présentant des caractéristiques rhéologiques intermédiaires entre un liquide et un gaz compressible. La phase liquide se présente sous forme d'un réseau cellulaire tridimensionnel, structuré, emprisonnant le gaz sous pression, et dans lequel le solide divisé se répartit aux interfaces liquide/gaz.

LES "MOUSSES CHARGÉES" - MISES EN OEUVRE - PROPRIÉTÉS



Schéma de principe de création de la mousse

La première étape consiste à concasser puis à broyer les chemises ou empilements de graphite. Afin d'obtenir un "slurry" ayant une granulométrie telle que 80% des grains obtenus soient inférieurs à 200 μm .

Comme l'indique le schéma ci-contre le mélange est obtenu par dispersion en continu du slurry obtenu dans une mousse pressurisée (foisonnement gaz/liquide en enceinte sous pression). Naturellement une étape de laboratoire permet de fixer le choix des agents tensio-actifs et stabilisants nécessaires au foisonnement et à la stabilité de la mousse.

Le mélange obtenu (mousse chargée) est compressible et les variations de sa masse volumique en fonction de la pression sont bien décrites par une équation d'état analogue à celle de Van Der Waals, dans laquelle le co-volume est le volume de la phase incompressible du mélange (solide à l'empilement compact plus eau interstitielle).

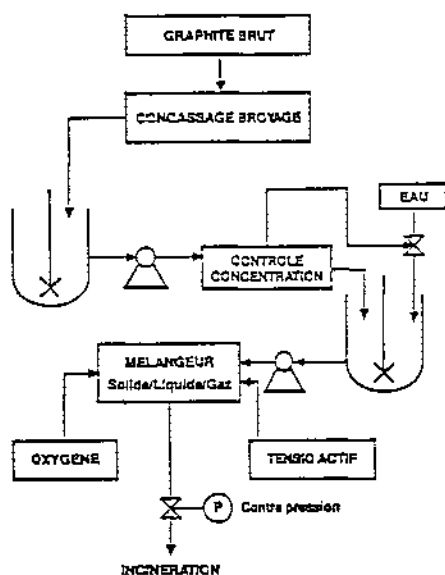
Ainsi le mélange triphasique, pressurisé lors de la phase de préparation est susceptible de transport en conduite par auto-détente par simple ouverture de vanne, ce qui permet par exemple, de supprimer les pompes de transport (fuites, érosion...), mais aussi de bénéficier des propriétés d'auto-pulvérisation du mélange lors de son introduction en enceinte de réaction.

De plus, cette formulation triphasique, permet de minimiser les contacts solide/solide, par aération du produit, abaissant ainsi sa viscosité apparente par rapport à la viscosité qu'aurait le produit en mélange solide/liquide à même concentration massique en solide. Autrement dit, la teneur massique en solide peut atteindre 80 à 85% dans la mousse pressurisée, alors qu'elle ne peut guère dépasser 60 à 65% dans un "slurry", et ce avec une relative indépendance à :

- la nature du solide (physico-chimie de l'interface solide/liquide), ce qui permet de limiter le choix des agents tensio-actifs à des molécules banales (agent moussant) et donc peu coûteuses ;
- la répartition granulométrique du solide divisé, ce qui permet de s'affranchir de la recherche de répartition multimodale en fluidification de mélanges solide/liquide.

La présence de liquide dans le mélange, par exemple ici l'eau, permet, malgré sa faible teneur, de supprimer les risques d'explosion dans les étapes de préparation et de manutention. De plus, ceci permet d'envisager l'utilisation de broyages en phase humide à l'amont de la préparation, et donc de minimiser les risques d'explosion ou d'envol dans les étapes de broyage.

Le produit fini peut être aisément chassé des conduites de transport ou d'injection par utilisation de gaz comprimés en cas d'indisponibilité du procédé aval (arrêt d'incinération par exemple). Le mélange peut être ainsi transféré dans un réservoir de confinement où la mousse chargée peut être "cassée" par dispersion d'agents anti-mousse, autorisant la minimisation du volume de l'enceinte de repos.

LE FOUR CYCLONE



Schéma de principe de fonctionnement du foyer cyclone

Le choix d'un foyer cyclone a constitué une alternative très intéressante pour la destruction du graphite, matériau difficile à incinérer parce que ne renfermant aucune matière volatile. Comme l'indique la figure ci-contre, le foyer utilise les mêmes principes aérodynamiques qu'un séparateur solide/gaz fonctionnant à froid.

L'entrée tangentielle du combustible/comburant (mélange gaz et particules solides) à très haute vitesse permet la centrifugation des particules vers les parois qui a pour effet de les désolidariser de la veine gazeuse ; de ce fait, elles séjournent plus longtemps dans le foyer et leur combustion s'en trouve améliorée ; ceci d'autant plus que l'effet cyclone provoquant une forte turbulence, les contacts combustible/comburant sont améliorés.

Le rôle de séparateur gaz/solide permet en outre aux cendres ou imbrûlés d'être évacués par le cendrier situé à la base du four.

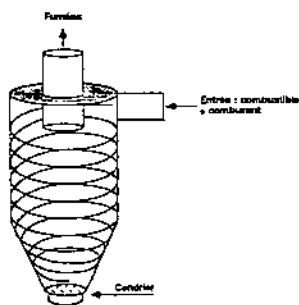
INTERET DE L'OXYGENE

Le choix de l'oxygène comme gaz de formulation et combustion permet :

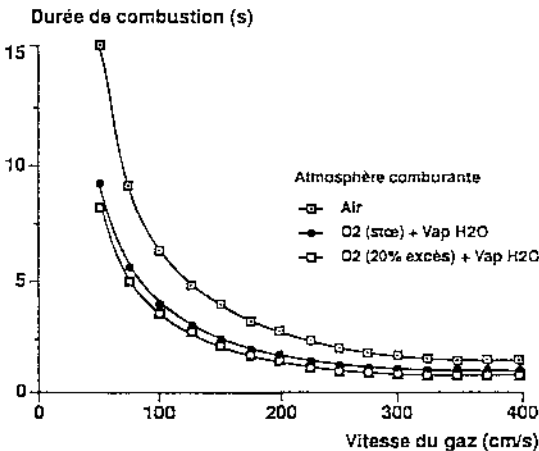

Comparaison de la cinétique de combustion d'un grain de graphite de 200 µm pour différentes compositions d'atmosphères comburantes

- l'amélioration de la cinétique de combustion des particules solides (voir courbe ci-contre)
- l'augmentation de la température adiabatique de flamme;
- la suppression des oxydes d'azote dans les produits de combustion;
- la réduction du volume d'effluents gazeux à traiter. Ainsi pour un même débit massique de graphite incinéré soit 150 kg/h et une même température d'incinération (1200°C), le débit volumique des fumées produit avec le procédé PG-WOM est de 1080 Nm³/h (dont 48% d'eau) alors qu'il serait de 2250 Nm³/h dans le cas d'un lit fluidisé.

CONCLUSION

L'intérêt de ce procédé réside dans sa sûreté liée à l'utilisation des "mousses chargées" en graphite, dans la qualité de la combustion grâce à l'auto-pulvérisation des mousses et à l'utilisation d'un four cyclone et dans l'écologie du procédé limitant le volume des fumées à traiter et évitant le dégagement d'oxydes d'azote.

TRAITEMENT DES ACIERS CONTAMINES
EN PROVENANCE DES REACTEURS UNGG G2 et G3
EN VUE D'UNE REUTILISATION DANS LE DOMAINE INDUSTRIEL

J.L. Decitre UDIN CEN Valrho
CEA - DCC/DERD/UDIN/RHO/CP
BP. 171 30200 - BAGNOLS SUR CEZE
FRANCE

Treatment of contaminated steel
from dismantling of G2 and G3 reactors,
for industrial reuse.

La limite d'activité pour la remise dans le domaine industriel des aciers en provenance du démantèlement des réacteurs G2 et G3 a été prise à :

- 1Bq/g en fonction du radionucléide principal se trouvant dans ces aciers (Co 60 à 95%),
- 1 Bq/cm²,
- contamination labile nulle.

L'objectif pris par UDIN est de remettre 90% des aciers extérieurs au caisson réacteur dans le domaine industriel.

La méthode adoptée pour atteindre cette objectif consiste en une caractérisation radiologique des morceaux de tuyauteries après découpe suivie d'un lavage permettant d'enlever la plus grande partie de la contamination labile puis d'une fusion dans un four à arc de grande dimension.

1 - NATURE DES INSTALLATIONS

- Réacteurs UNGG (Uranium Naturel Graphite Gaz) plutonigène et électrogène (250 MW T./40 MW E)

Le gaz calo-porteur était du dioxyde de carbone à la pression de 15 bars.

L'ensemble des tuyauteries était en acier ordinaire.

Le coeur du réacteur était contenu dans un cylindre à axe horizontal en béton, d'épaisseur 3 mètres.

2 - DATES REPERES

	<u>G2</u>	<u>G3</u>
- Mise en service	07/1958	06/1959
- Mise à l'arrêt	02/1980	06/1984
- Prise en charge UDIN	02/1982	01/1986
- Achèvement prévu du démantèlement pour les 2 réacteurs :		
Niveau 2 - fin 1993		
Niveau 3 - décision en cours d'étude, après construction d'un pilote d'incinération de graphite.		

3 - MAITRISE D'OEUVRE DU DECLASSEMENT

- La maîtrise d'oeuvre du déclassement est assurée par l'Unité de Déclassement des Installations Nucléaires du Commissariat à l'Energie Atomique, CEA/DCC/UDIN. Cette unité spécialisée dans le déclassement et le démantèlement des installations nucléaires (réacteurs de tous types, laboratoires chauds ...) travaille dans la France entière sur tous les sites du CEA et de la COGEMA (3 sites dans la zone de Paris, La Hague, Brennilis, Grenoble, Pierrelatte, Marcoule, Cadarache).

4 - STRATEGIE

La stratégie repose sur deux axes principaux:

- A) Quantifier le plus précisément possible tous les éléments du réacteur et des circuits associés.
- B) Traiter les produits du démantèlement pour remise dans le domaine industriel de la plus grande partie aux coûts économique et radiologique les plus faibles.

Dans ce domaine, et après avoir étudié les résultats de la quantification des circuits annexes (4000 tonnes de tuyaux servant à véhiculer le CO₂, fluide de refroidissement), UDIN a décidé de fondre l'ensemble des aciers en provenance de ces circuits après un lavage sommaire à l'eau sous haute pression. Les résultats des mesures d'activité entreprises sur les premières 1000 tonnes, montraient que 90 % de ces aciers pouvaient être remis dans le domaine public (contamination labile nulle, contamination surfacique très largement inférieure à 1 Bq/cm² et contamination massique de l'ordre de 1 Bq/g).

Le dimensionnement des installations de fusion construit dans les bâtiments de l'un des réacteurs a été calculé pour permettre de fondre 5.000 à 10.000 tonnes d'acier contaminé par an, avec une contamination moyenne massique maximum de 250 Bq/g.

Caractérisation des installations

La caractérisation a été réalisée par mesures directes (frottis, sondes), et par carottage vertical, sur toute la hauteur du réacteur.

A l'intérieur des coeurs des réacteurs, l'activité des aciers varie de $10E+3$ à $10E+6$ Bq/g, la contamination est de l'ordre de 200 Bq/cm² (95% due au Co60, 5% due au Cs137).

A l'extérieur, les aciers sont uniquement contaminés, entre 40 et 200 Bq/cm².

Traitement

Les aciers internes seront lavés pour diminuer leur contamination, puis découpés pour être stockés sur un site de surface.

Les aciers extérieurs seront lavés sous haute pression et fondus. Les corps creux qui n'ont pas besoin d'être découpés en fonction de la dimension du four choisi seront nettoyés par mousse (procédé développé par le CEA/UDIN).

Le four choisi est un four à arc de capacité 15 tonnes (8 MVA) possédant une ouverture de 2,5 m. ; il est installé dans un bâtiment confiné et ventilé, à l'intérieur du hall du réacteur G3. La première fusion a été réalisée début octobre 1991.

Contrôle

Les pièces démantelées sont transportées en containers après découpe (dimensions < 1,7 m. x 1,7 m. x 1,3 m.), à proximité du four et introduites à travers un sas dans l'aciérie. La gestion radiologique est basée sur un suivi complet des morceaux découpés. Après un contrôle à l'entrée de la salle de préparation (contrôle à la sonde d'un container entier après étalonnage et établissement d'une fonction de transfert), les pièces sont chargées dans des paniers en les triant de façon à obtenir des charges de coulée < 1 Bq/g.

Les déchets de fusion seront traités pour être stockés sur un site de surface.

Les lingots obtenus seront orientés dans 3 directions principales :

- si l'activité est < 1 Bq/g , remise dans le domaine public,
- si l'activité est comprise entre 1 et 100 Bq/g, recyclage dans le domaine nucléaire,
- si l'activité est > 100 Bq/g , stockage sur un site de surface ou décroissance sur le site des réacteurs.

La coulée sera caractérisée par l'analyse fine d'un échantillon recueilli dans le four avant coulée ; un contrôle statistique de 5 lingots par coulée permettra une dernière vérification.

UDIN G3

FOUR DE FUSION

CAPACITE 15 T. - PUISSANCE 8 MVA

FUSION DES ACIERS FAIBLEMENT CONTAMINES

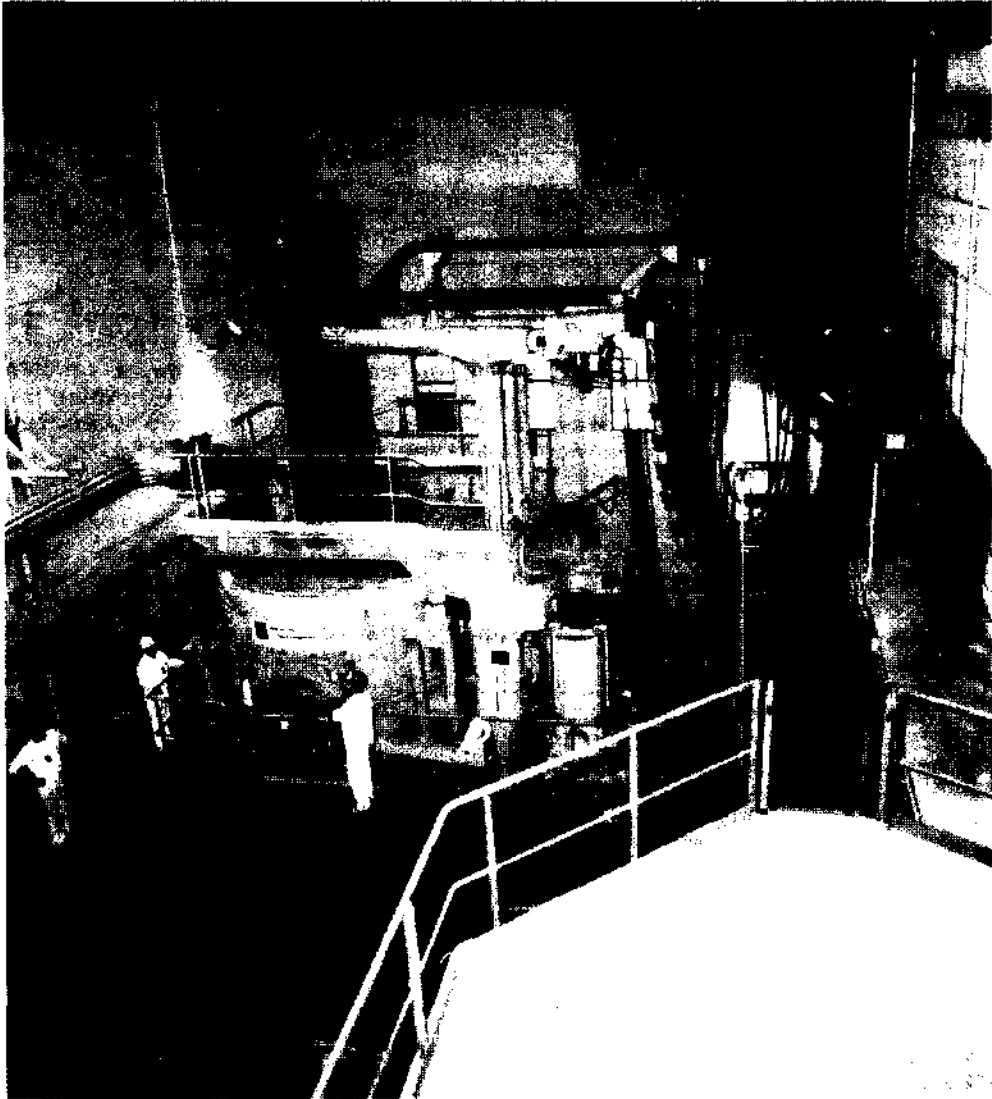

ETUDE D'UN SYSTEME DE MICROPRELEVEMENTS SURFACIQUES PAR IMPACT LASER POUR L'ANALYSE ULTERIEURE DE SURFACES CONTAMINEES

J.J. Gaumet*, F. Membrey*, A. Chambaudet*, G. Madelaine**,
D.Boulaud** et P. Zettwoog**

* Laboratoire de Microanalyses Nucléaires, U.F.R. Sciences de Franche-Comté, La Bouloie, Route de Gray, 25030 BESANCON CEDEX - FRANCE

** Commissariat à l'Energie Atomique, IPSN/DPT, BP. 6, 92265 FONTENAY AUX ROSES CEDEX - FRANCE

STUDY OF A MICROSAMPLING SYSTEM BY LASER IMPACT FOR ANALYSIS OF CONTAMINATED SURFACES

ABSTRACT

A method of microsampling by laser YAG is described. The aim is to take a very small amount in surface of contaminated materials (nuclear or chemical contamination). The use of an Electric Aerosol Analyser allowed to distinguish two different phenomenous of interaction between a power laser and a target: ablation (hole formation of the target less than 0,5 mm of diameter) and desorption (invisible surface sampling). The rate of desorbed material is estimated by regression. Some perspectives are also discussed.

INTRODUCTION

Nous présentons une méthode de prélèvement de matière par impact laser qui se caractérise par:

- un dégât petit à la surface d'une cible (diamètre du cratère formé inférieur à 0,5 mm)
- un produit prélevé facilement analysable par différentes méthodes physico-chimiques.

L'interaction entre un faisceau laser et une cible peut se manifester sous deux formes très différentes selon l'énergie, l'angle d'incidence, la défocalisation du faisceau laser et les propriétés physico-chimiques du matériau cible (coefficient de réflexion, paramètres thermodynamiques,...). La première possibilité est une ablation avec formation d'un impact et production de microgouttelettes de liquide et d'un plasma. Ce dernier, composé de particules partiellement ionisées, se refroidit très rapidement. Les clusters créés condensent et forment un aérosol composé de microbilles dont la particularité réside dans une distribution en taille relativement monodispersé (Voir Fig.1)[1]. La seconde consiste en une description [2] à la surface de la cible. L'unique produit résultant de l'interaction est un aérosol. Dans ce cas, la surface irradiée ne montre pas de dommages "visibles". L'aérosol formé est facilement récupérable.

APPAREILLAGE

- *Système de prélèvement*

Le prélèvement de matière est effectué dans une cellule en duralumin (voir Fig.2), comprenant une entrée et une sortie du gaz vecteur. Une fenêtre en saphir permet le passage du faisceau laser, celui-ci interagissant avec la surface à analyser avec un angle d'incidence nul. Les paramètres du faisceau sont regroupés dans le tableau 1:

Laser Longueur d'onde	Energie faisceau	Duree d'impulsion	Puissance crête	Densité de puissance surfaccique	Distance focale de la lentille de focalisation
Nd-YAG 1,06 μm	0,1-0,3 J	100-150 μs	1000-3000 kW	$10^6 - 10^7$ W.cm^{-2}	40 ou 100 mm

Tableau 1: Paramètres du faisceau laser utilisé

- Récupération de la matière expulsée

Lors de l'interaction laser-matière, il est nécessaire d'éviter les projections de gouttelettes difficilement récupérables et contaminant les parois de la cellule.

A l'opposé, l'aérosol (voir Fig.1) possède des propriétés bien différentes du liquide projeté dans le cas d'une ablation laser. Les microbilles formés lors du refroidissement brutal du plasma sont très bien localisées laissant l'enceinte de prélèvement propre. En effet, les particules obtenues sont submicroniques, ce qui rend leur transport très aisé au moyen d'un gaz vecteur.

Grâce à cette facilité de déplacement, l'aérosol peut être récupéré sur un filtre Millipore. Au moyen d'un diaphragme, une très petite quantité de matière est concentrée sur une très petite surface du filtre. L'analyse du dépôt par des techniques de microanalyses telles que la spectrométrie LAMMA (Laser Microprobe Mass Analyser) [3] et la microsonde d'analyse X (Fig.3) est rendue possible.

COMPARAISON ENTRE ABLATION ET DESORPTION PAR ANALYSE DE L'AEROSOL FORME

Dans l'étude qui suit, la chambre d'échantillonnage est couplée à un Analyseur Electrique d'Aérosol de la firme Thermo System Inc. (Fig.2). Ce compteur de particules permet de déterminer le nombre et les dimensions des microbilles formées. Les Fig.4 et 5 (respectivement pour une défocalisation de 0 mm et +10 mm par rapport à la surface de la cible) montrent les différentes allures pour les deux phénomènes résultant de l'interaction laser-cible métallique (or 14 carats). Pour une focalisation non nulle (sans formation de cratère), la décroissance du nombre d'aérosols en fonction du temps d'irradiation est continue pour tendre asymptotiquement vers une valeur limite: nous sommes en présence d'une désorption. En revanche, une focalisation du faisceau laser à la surface de la cible engendre une densité d'énergie très élevée générant un cratère sur le matériau. La concentration en aerosol varie de manière importante et le phénomène de décroissance dans le cas d'une désorption est stoppé: il y a ablation.

Par régression, nous avons exprimé le volume de matière ablaté en fonction du temps d'irradiation.

La modélisation proposée est schématisée à la Fig.6, le volume V prélevé étant donné par la relation (1):

$$V = \frac{D}{\alpha} \left[\frac{1}{\beta} - \frac{1}{\alpha t + \beta} \right] \quad (1)$$

avec D: débit du gaz vecteur

t: temps d'irradiation

α et β : coefficients provenant de l'expression de la régression

(2) entre v, volume d'aérosol prélevé par unité de temps, et t.

$$\frac{1}{v_{0,5}} = \alpha \cdot t + \beta \quad r = 0,990 \quad (2)$$

(avec $\alpha = 9,70 \cdot 10^{-5}$ et $\beta = 22,46 \cdot 10^{-4}$).

On en déduit la profondeur ablatée z (3):

$$z = \frac{4V}{\Delta \pi} \quad (3)$$

avec Δ : diamètre du trou créé (supposé être un cylindre de profondeur z).

Dans le cas de l'or 14 carats, avec $\Delta = 3000 \mu\text{m}$, on obtient un volume V de matière prélevée égal à $3 \cdot 10^7 \mu\text{m}^3$ avec une profondeur z = 2,4 μm .

DEVELOPPEMENTS ET PERSPECTIVES

Les expériences présentées ci-dessus confirment les options choisies lors de la conception de la cellule de prélèvement:

- l'aérosol produit peut être transporté au moyen d'un gaz vecteur
- une gamme de défocalisation importante est possible permettant une ablation ou une désorption.

Nous avons également montré la possibilité de vaporiser des matériaux sans créer des dégâts apparents, ceci peut s'avérer important pour des applications de cette technique dans le cadre d'authentification d'oeuvres d'art (statuettes, bijoux, peintures,...) ou de contrôles non destructifs.

La méthode présentée est intéressante dans le cas de surfaces contaminées par voie radioactive ou chimique. Ainsi, le prélèvement à l'intérieur de sites irradiés (réacteur nucléaires, circuits primaires,...) peut être envisagé grâce à l'utilisation d'une part de fibres optiques en couplant le laser et la cellule et d'autre part de la robotique.

BIBLIOGRAPHIE

- [1]. Matsunawa, A., Katayama, S., Susuki, A. et Ariyasu, T., Laser Production of Metallic Ultra-Fine Particles, Transactions of JWRI, 15, 61-72, (1986).
- [2]. Eloy, J.F., Les Lasers de Puissance, Ed. Masson (1985).
- [3]. Muller, J.F., L'ionisation laser des surfaces en spectrométrie de masse, Analusia, v18, n°19, 116-117 (1990).
- [4]. Liu B.Y.H. et Pui D.Y.H. On the Performance of the Electrical Aerosol Analyser, J. Aerosol Science, 6, 249-264 (1974).

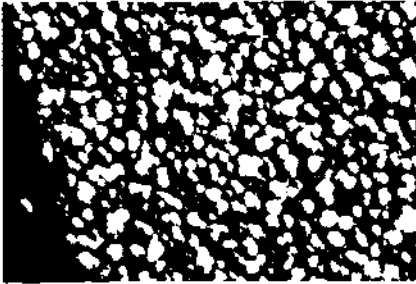

Fig. 1:

Aérosol de Zinc déposé sur une lame de verre
Photo M.E.B. Grossissement: $\times 20000$

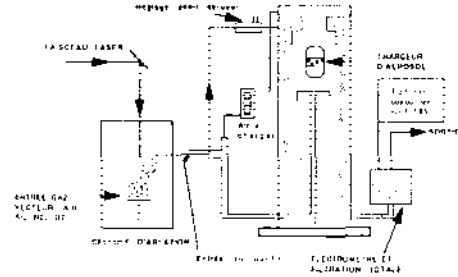

Fig. 2

Schema simplifié du système d'aérosol laser coupé à l'oxygène électrolytique

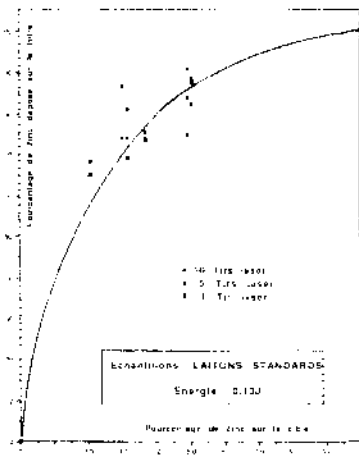

Fig. 3

Courbe de dépôt de zinc sous irradiation laser dans le phénotolène
de l'oxygène de l'oxygène électrolytique et Zinc dans à zinc

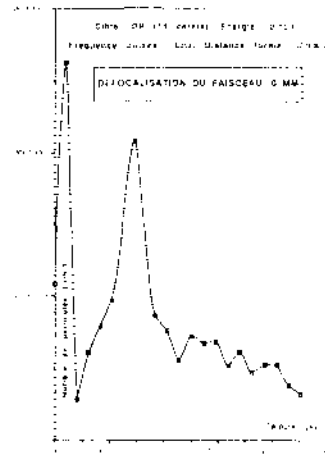

Fig. 4

Nombre de particules par volume d'aérosol en fonction de l'énergie laser

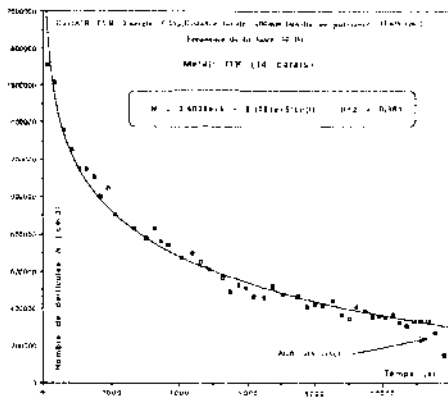

Fig. 5:

Nombre de particules séparées par impact laser en fonction de l'énergie d'irradiation

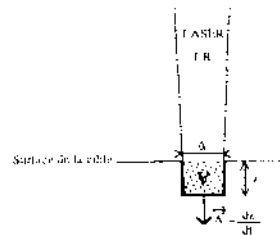

Fig. 5:

Modélisation des paramètres d'un impact généré
au moyen d'un faisceau laser

**GUIDE FOR DECONTAMINATION
IN P.W.R. POWER PLANTS**

J. HERISSON
C. GLORENNEC

Electricité de France
Service de la Production Thermique
Paris - La Défense

Nuclear power plant components or equipment often need to be more or less decontaminated before maintenance. In order to coordinate the activities of the various maintenance specialists belonging to the Corporate or Site Organizations, the Management of EDF/Nuclear and Fossil Division has created a "Decontamination Task Force". The first objective of this Task Force was to prepare this "Decontamination Guide for Nuclear Power Plants".

This document is the result of a close collaboration, within a specific working group, between representatives of Nuclear & Fossil Division (from Nuclear Power Plants & Corporate Departments) and EDF Project & Construction Group. It will provide assistance to Nuclear Plants Operators in the very specific field of decontamination.

INTRODUCTION

Human external exposures and contamination risks increase over the years, with nuclear plant operation time. This applies essentially to maintenance personnel. In order to reduce dose rate, conventional radioprotection measures can be efficiently improved by equipment decontamination.

However, decontamination should not be considered as a panacea and should only be used after an in-depth and critical evaluation of the technical, dosimetric and economical aspects (ALARA).

The objective of this Guide is to provide the operators with methods and techniques which will help them to take decisions in the decontamination field.

This Guide describes essentially decontamination techniques available for the maintenance of Pressurized Water Reactors. Some of these techniques might be applied, after evaluation, to other types of reactors.

It is not only useful to those in charge of implementing these techniques, but also to planners having to integrate decontamination techniques in maintenance and working procedures.

The Guide is divided into two parts :

- part I contains general information about decontamination techniques, and gives the basics for obtaining an acceptable level in this discipline,

- part II describes the decontamination methods and techniques available to Power Plants. It is to be considered as prescriptive ; in fact, all decontamination techniques not included in this book have to be implemented very carefully, after consulting with Company specialists.

It is an evolving Guide, as far as the prescriptive part is concerned. It depends essentially on experience feedback from all the users.

DECONTAMINATION GUIDE

PART I : PRESENTATION AND GENERAL INFORMATION

The first chapter describes the technical aspects of equipment decontamination and covers the following topics :

- Radioactive contamination cases in a PWR NPP
- Thresholds - Contamination measurement
- Contamination prevention
- The equipment to be decontaminated
- Decontamination objectives
- Description of the main decontamination methods
- Decision criteria
- Decontamination liquid treatment and waste processing
- Safety - Health Physics - Environment

The second chapter covers EDF quality organization in the decontamination field :

- Policy :
- Decontamination activities
- How to attain quality
- Who is suppose to do what
- Qualification of decontamination personnel
- Acceptance and qualification of a decontamination process

- Implementation :
- When planning a decontamination :
 - Responsibility of the initiator
 - Responsibility of the planner
 - Responsibility of the decontamination crew leader

Part I (and essentially chapter II) are related to the French regulations applicable to operators and contractors.

PART II : METHODS AND TECHNIQUES

This part is essentially technical and addresses the personnel actually involved in equipment decontamination. It provides a list of applicable methods, depending on the type of contamination and the basic material of the component.

The optimum method can be sought in two ways :

- by nuclear power plant component : the guide proposes 14 logical search flowcharts for the following component types :

- M1 Steam Generator
- M2 Reactor cavity and spent fuel pit walls
- M3 Reactor coolant pump
- M4 Charging pump
- M5 Residual Heat Removal (RHR) pump
- M6 CVCS regenerative heat exchanger
- M7 CVCS non-regenerative heat exchanger and RHR heat exchanger
- M8 RCS pipes
- M9 CVCS/RHR pipes
- M10 RCS valve
- M11 RHR/CVCS valves
- M12 Spent fuel element shipping cask
- M13 Electrical/electronic/optical equipment
- M14 RCS Pressurizer

- by basic material : the guide proposes 11 logical search flowcharts :

- L1 Stainless steel (high temperature contamination)
- L2 Stainless steel (low temperature contamination)
- L3 Nickel based alloys (Inconel..) (high temperature contamination)
- L4 Carbon steel
- L5 Cobalt based alloys (stellites)
- L6 Copper based alloys
- L7 Aluminium and zinc based alloys
- L8 Lead
- L9 Concrete
- L10 Plastic - Rubber
- L11 Liners - Paints

These logical flowcharts indicate a certain number of decontamination methods applicable to the relevant equipment. The methods are described in technical files indicating :

- Qualification of the process : the EDF specialists in the different fields involved (metallurgy, chemistry, etc...) have collected sufficient information and test results and can thus authorize the use of this process on the relevant equipment, as described in the file. This authorization does not necessarily cover all specific requirements prescribed by the Regulatory Bodies, since adherence to the rules is the users's responsibility.

- Applicability : a list of the materials and equipment that can be treated by the corresponding process. It also lists the materials and equipment on which it should not be used.

- Operating instructions and procedures : it describes the various chemical phases and the necessary equipment.

- Operating instructions and procedures : it describes the various chemical phases and the necessary equipment.

- Expected results : it indicates the results usually obtained by using the process, and more specifically the expected dose rate reduction factor.

- Waste processing methods : it indicates the various methods for processing the resulting effluents. These methods are in accordance with the French regulations related to environmental protection.

- Advantages and drawbacks : it indicates the strong points of the process and also its shortcomings.

- Historical aspect : it indicates some worldwide results of previous use of the process.

- Basic diagram : it shows basic set-up and installation drawings of the process.

- List of accepted and similar commercial products : it enables a Nuclear Operator to implement the process himself, providing these products or the process are not patent protected.

- List of EDF qualified vendors and contractors : it gives the list of those contractors that have satisfied the EDF Quality Assurance requirements and are authorized to work on EDF equipment.

The guide contains 40 technical files concerning about decontamination methods.

Data and information are extracted from technical publications and EDF guarantees neither the efficiency of the methods nor the expected results. It is however now being satisfactorily used by the EDF nuclear sites.

The guide is now available in its French version. An English version could be published in 1992, depending on the results of an ongoing market survey.

DECOMMISSIONING OF NUCLEAR FACILITIES IN GERMANY
RADIATION EXPOSURE CAUSED BY THE UNHARMFUL REUSE OF
RADIOACTIVE RESIDUAL MATERIALS

P. Guglhör, K.-H. Lehmann, B. Jähnert
Technical Inspection Agency of Bavaria (TÜV Bayern)
Munich, Germany

ABSTRACT

The decommissioning of nuclear facilities causes the release of radioactive material. The radiation exposure of the public was calculated and contamination limits for the un-harmful reuse of residual material were derived.

INTRODUCTION

As a consequence of the strong requirements of the German Atomic Energy Act radioactive residual material or dismantled radioactive components from nuclear facilities must be reused in an un-harmful way.

As an independent expert organisation TÜV Bayern checked how these requirements had been met in the nuclear licensing procedure for the NPP

- Kahl (25 MW_e, BWR),
- Niederaichbach (100 MW_e D₂O-moderated, CO₂-cooled),
- Gundremmingen (250 MW_e, BWR).

LIMITS FOR UNHARMFUL REUSE

After 2 years of reactor-operating time the NPP Niederaichbach was shut down in 1974. It was the first nuclear facility in Germany which was applied for decommissioning. Therefore TÜV Bayern get most experience in the valuation of the radioactive material of this plant.

Especially for concrete, steel and some other materials (e. g. insulation material) the radiation exposure of the public was calculated by using appropriate exposition scenarios. Contamination limits for the un-harmful reuse were derived. These limits depend on the nuclide mixture as well as the procedure for the clearance measurements.

The nuclide mixture depends on the material. In the activated steel there is mainly Fe 55, Co 60, and Ni 63, in the activated concrete there is mainly Ba 133, Co 60, Eu 152, and H 3.

At the time TÜV Bayern carried out the assessment on

the decommissioning of the NPP Niederaichbach no regulations for the release of radioactive material for unarmful reuse did exist. TÜV Bayern proposed such regulations by calculating the radiation exposure of the public. The radiation exposure caused by the release of radioactive material should be small compared with the range of the variation of the natural radiation.

As a result of our assessment of the release of former contaminated material it was not allowed to exceed the following two limits:

- mass specific activity,
(10^{-5} times the allowances per gramm as specified in the German Radiological Protection Ordinance (GRPO), e. g. for 100% Co 60 it would be 0.37 Bq/g),
- surface contamination,
(0.37 Bq/cm², required by the German Radiological Protection Ordinance)

The first limit restricts the amount of activity released and should be measured in an easy way (e. g. gamma-spectroscopy) using a reference nuclide composition. The second limit is a requirement of the GRPO and is to prove for every material released from the controlled area. For more than one radionuclide or a mixture of radionuclides of known composition the allowance shall be determined as the sum of the nuclide portions. In the licence for the decommissioning of the NPP Niederaichbach a nuclide mixture for the release of radioactive material was determined by the licensing authority. These nuclides are H 3, Mn 54, Fe 55, Co 58, Co 60, Ni 59, Ni 63, Nb 94, Cs 134, Ba 133, Eu 152, and Eu 154. For the mass specific activity of the NPP Niederaichbach you get the following condition:

$$\sum_{i=1}^m \frac{A_i}{F_i} + \sum_{j=1}^n \frac{B_j}{F_j} < 10^{-5}/g$$

- A_i : measured specific activity of the nuclide i
- B_j : detection limit of the nuclide j
- $F_{i,j}$: allowance of the nuclide i,j according to the GRPO
- m : number of nuclides with measureable activity
- n : number of nuclides with detection limit

The amount of radioactivity of some nuclides, e. g. Fe 55, Ni 59, and Ni 63, was measured separately in laboratory because they are emitting no gamma-rays. Because of the low amount of these nuclides in the material the radioactivity was not measureable. According to the licence it was necessary for these nuclides to use the detection limits

when proving that the clearance levels are met. The sum of the measured activity and the detection limits for all layed down nuclides shall not exceed the mass specific clearance level. Up to now a mass of about 740 Mg was released with a mean radioactivity of about 0.2 Bq/g. Considering the amount of the activity due to detection limits, one gets about 0.2 Bq/g. So the real activity of the material is only a part of it and will be significantly lower than 0.1 Bq/g.

With the materials and activities released up to now the theoretical exposition scenarios have been checked. It turned out that the actual radiation exposure of individuals of the public is significantly lower than the values calculated for the licensing procedure.

In 1987 the National Commission of Radiological Protection (SSK) made a recommendation for the unharmed reuse of radioactive steel released by a NPP. In this recommendation a value of 0.1 Bq/g for the mass specific activity should be adequate for an unrestricted release.

Because of the conservative procedures for the release of radioactive material one can state that the succeeding recommendation of the SSK is met in practice at NPP Niederaichbach.

VALDEC-F PROJECT FOR THE TREATMENT OF LOW ACTIVITY SCRAP STEEL

By Henri GODARD - SOCODEI - France

----*

Abstract

Maintaining -or dismantling- nuclear plants involves the issue of more or less contaminated scrap steel. Those scraps are today usually either stored on the plants or disposed of as nuclear wastes.

The VALDEC-F project consists in transforming the scraps at a specific facility in order to produce moulded items that are used in the nuclear field.

Basically the facility includes sorting equipments (according to the activity, iron or steel, ...), preparatory operations to melting, and casting.

Tonnages exceeding the orders of moulded items will be turned into ingots and temporary stored.

The VALDEC-F project (1 500 t/year) contributes in France to mastering the risks due to low level wastes as well as the economy of their treatment.

Résumé

L'entretien ou le démantèlement des installations nucléaires génère des ferrailles plus ou moins contaminées qui sont habituellement, soit conditionnées en vue de leur stockage définitif, soit accumulées sur les sites de production.

Le projet VALDEC-F consiste à transformer ces ferrailles dans une usine spécifique pour en faire des produits moulés, notamment des blindages utilisés dans le domaine nucléaire.

Les matériels principaux concernent le tri des ferrailles, leur préparation à la fusion et la réalisation de produits moulés. Les tonnages de ferrailles qui excèdent les commandes en produits moulés seront lingotés pour en réduire le volume.

Le projet VALDEC-F (1 500 t/an) est, en France, un élément nécessaire à la maîtrise des déchets de faible activité, tant au plan économique qu'au plan de la prévention de la dissémination de la contamination.

Brève histoire du projet VALDEC-F

Les essais de fusion de ferrailles faiblement contaminées, notamment ceux réalisés par EDF en 1985-1986, ont laissé entrevoir l'intérêt d'un tel traitement de ce type de déchets de faible activité :

- pour les ferrailles dont l'activité va de quelques Bq/g à 1 kBq/g, possibilité de réaliser des produits moulés pour l'industrie nucléaire, notamment des blindages entrant dans les colis de déchets irradiants des centrales ;
- pour les activités de l'ordre du Bq/g, mise sous une géométrie (lingots homogènes) permettant de mesurer par une méthode industrielle simple une radioactivité qui n'émerge guère du bruit de fond ;
- pour les activités supérieures à 1 kBq/g, réduction maximale du volume en vue du stockage définitif en centre de stockage de surface.

Il fallait dès la conception d'une installation, l'envisager en tant qu'usine qui permette de gérer à l'optimum économique des matières et des activités, la fusion n'étant qu'une phase de la transformation.

Les études technico-économiques conduites par EDF de 1988 à 1990 ont débouché sur un cahier des charges qui définit notamment :

- la capacité de réception : dimensions, masse, activité des colis à traiter ;
- la capacité de traitement : tonnages annuels pouvant être triés, découpés, fondus ;
- la capacité de production : tonnages de produits moulés, d'acier recyclable, de déchets.

Sur la base d'un avant projet suffisamment détaillé, étaient enfin définis les principes de surveillance, les mesures et contrôles qui seront mis en oeuvre lors de l'exploitation : SOCODEI a déposé en fin d'année 1991 les études d'impact et des dangers qui font partie de la procédure d'autorisation d'exploiter une telle installation en France.

SCHEMA FONCTIONNEL DES INSTALLATIONS

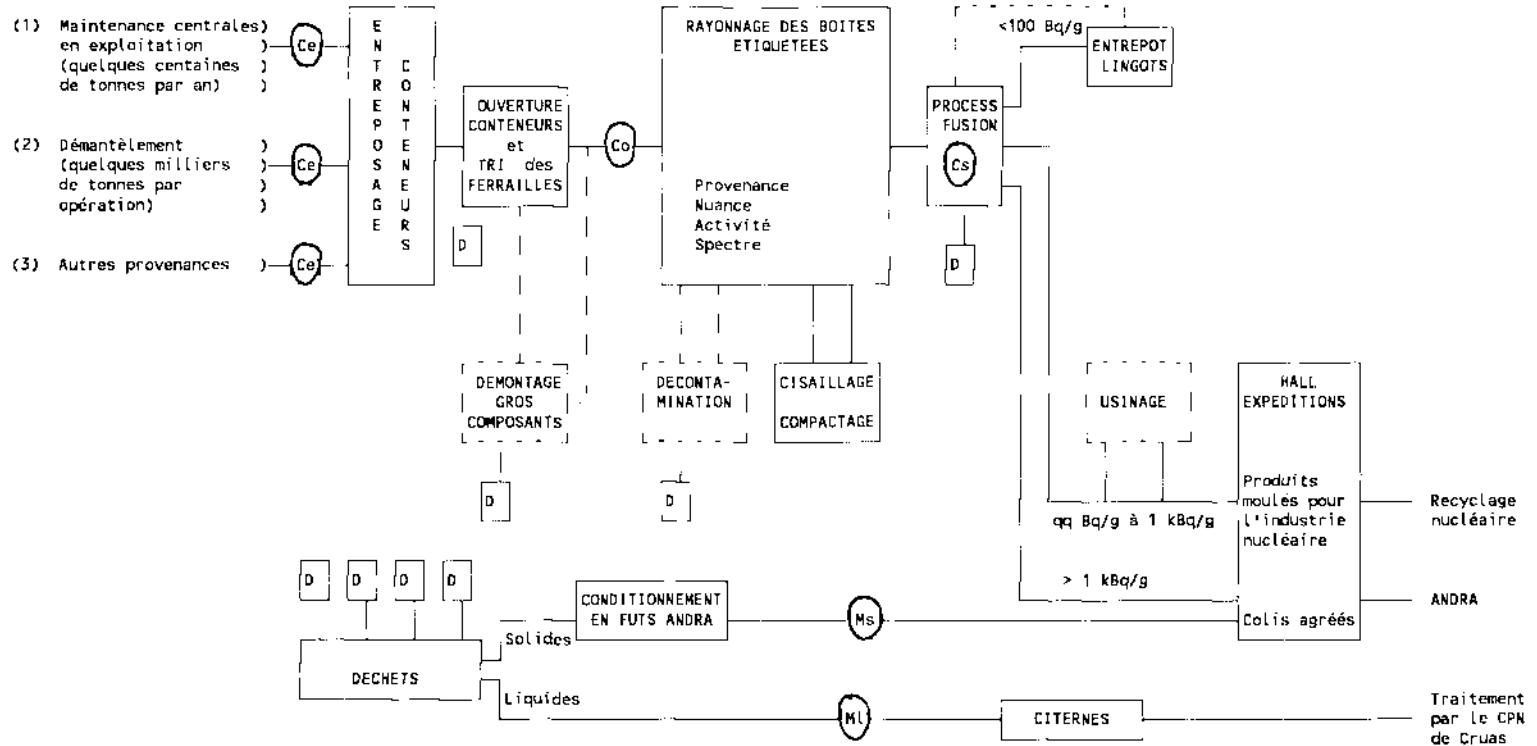

1445

Légende

 Opération réalisée éventuellement

(1) (2) (3) Ferrailles entrant dans les spécifications d'acceptation par l'usine

Ce Contrôle "à l'entrée"

Co Contrôle "à l'ouverture"

Cs Contrôle "en sortie" sur échantillon de coulée

ML Mesure sur les effluents

Ms Mesure sur les déchets solides conformément aux prescriptions de l'ANDRA

Principales caractéristiques du projet VALDEC-F

Les ferrailles de faible activité proviennent de la maintenance des centrales nucléaires en exploitation, du démantèlement des centrales plus anciennes, ou encore d'autres installations, pour autant que leurs caractéristiques soient compatibles avec les installations.

Le traitement consiste principalement en la gestion des ferrailles (nuances, masse, radioactivité) et leur fusion, en vue, soit de leur revalorisation, soit de la réduction de leur volume.

L'usine peut traiter 1 500 tonnes de ferrailles par an en travaillant en un poste.

Elle peut recevoir des colis jusqu'à une masse de 40 tonnes, et de dimensions jusqu'à 8' x 8'6" x 40 pieds.

Peuvent être traitées sans adaptation des installations, des pièces dont la masse est inférieure à 15 tonnes et dont l'activité sur 2 tonnes est nulle part supérieure à 15 000 Bq/g.

Les ferrailles livrées dans des conteneurs mis à disposition par SOCODEI et d'activité ne dépassant par 1 kBq/g, bénéficient de conditions particulières.

Des prestations auxiliaires telles que la décontamination d'une pièce en alliage à haute valeur marchande, ou l'usinage de produits moulés peuvent être réalisées.

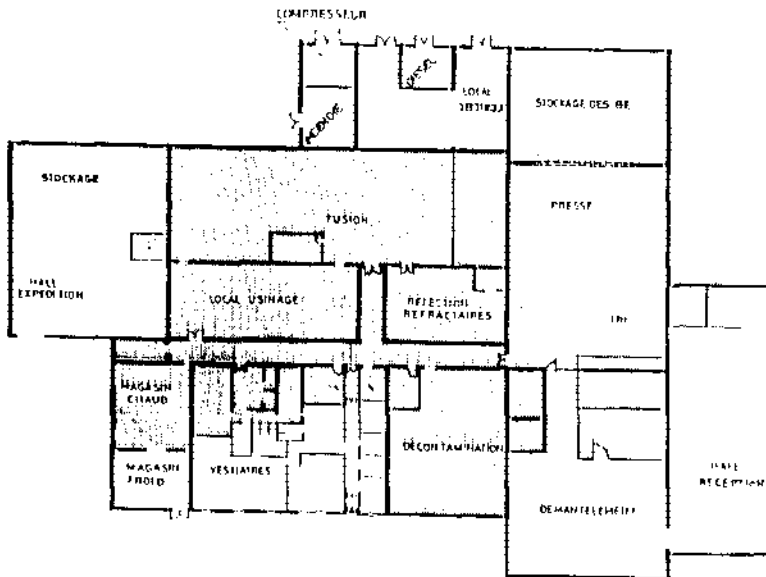

FRENCH EXPERIENCE WITH ELECTROPOLISHING

P. SAURIN - C. WEBER - N. ENGLER (FRAMATOME) - B. LANTES -
A. BRISSAUD - P. RIDOUX (EDF) - P. BESLU - S. ANTHONI (CEA)
J.P. CIZEL (STMI)

ABSTRACT :

Following the results obtained in CHINON B1 comparing deposited activity observed on different surface finishes EDF decided to electropolish steam generator channel heads (S.G.C.H.) in order to reduce operator dose during plant maintenance. The qualification tests were performed on steam generator materials (Inconel 600 and S.S. 308 L) with the full on site operational equipment (i.e. a sealed sucker). In 1988 the 4 SGCH of NOGENT 2 were electropolished. In 1990 we observed a dose rate reduction of 45 % at NOGENT 2 compared to NOGENT 1.

Other French experience is electropolishing of 27 S.G.CH, since 1988

1. INTRODUCTION

French attention has also been focused on surface finishing and tests carried out at CHINON B1 NPP to evaluate the efficiency of mechanical polishing, electropolishing and combination of both [1].

The results after exposure of steam generators manway covers for up to three reactor cycles indicated a reduction factor of 3 in the radiation field following the use of electropolishing compared to the as received surface finish [2].

Based on these attractive results and also cost considerations it was decided by EDF to electropolish the S.G.C.H. bowl and partition plate.

Following this decision feasibility and qualification programmes were developed to exclude unacceptable behavior and detrimental effects (i.e. material degradation) [2, 3].

2. INDUSTRIAL APPLICATION

2.1. FRAMATOME electropolishing experience

The French experience of S.G.C.H. electropolishing for SG channel head is summarized in table n° 1.

Table 1 : French experience of S.G.C.H electropolishing

Year	Month	Electropolishing % of total surface area	NPP	Number of S.G.
1988	February	60 %	NOGENT 2	4
1988	July	60 %	CATTENOM 3	4
1989	February	80 %	PENLY 1	4
1989	July	80 %	GOLFECH 1	4
1989	Oct.-Dec.	80 %	DAMPIERRE 1	3
1990	May	80 %	CATTENOM 4	4
1991	Jan.-Feb.	80 %	PENLY 2	4

2.2. Description of an electropolishing operation

A typical electropolishing operation takes approximately 5 Weeks for 8 channel heads, including all the initial and final inspections and quality controls :

- surface pH, conductivity of the final rinsing water,
- microscopic examination on base surfaces and replicas to perform microscopic and SEM examinations,
- surface profilometry (roughness curves).

Metallurgical inspections also takes place during the electropolishing operation.

The electrolyte is composed of a mixture of sulfuric and phosphoric acids.

Electropolishing tools support the electropolishing sucker (STMI patent) which contains the cathode (S.S. disk) [3].

Figure 1 : During "Mosquito" electropolishing

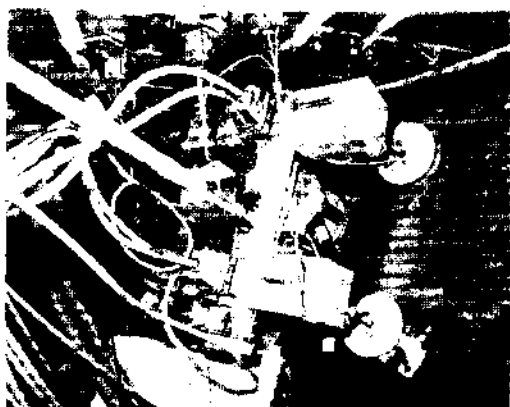

Figure 2 : Partial polished surface on the clad bowl (using "Mosquito" tool)



3. METALLURGICAL RESULTS

Two types of results are recorded as follows

* roughness results

- regular, uniform and extremely smooth surfaces are obtained.

Figure 3 shows examples of initial and final surface profilometry measurements. The micro-roughness has been eliminated after electropolishing.

Figure 3 : Roughness curves on SS 308 L Profiles in X direction μm - from CATTENOM 3

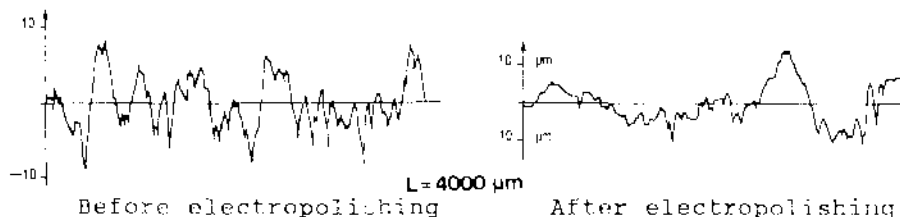

The profilometry measurements are made directly on the S.G.C.H. base surfaces and are statistically analysed by STMI.

* Metallographical results

- no pitting, no etching, or any other undesirable side effects of corrosion .
- only a slight intergranular grain boundary attack on Inconel 600 (i.e. the partition plate) and a very low selective dissolution of delta ferrite on SS 308 1 (the weld overlay).

All replica are immediately examined optically during the electropolishing operation by the metallurgical team, and then characterized at the UNIREC metallurgical laboratory by SEM examinations, occasionally with supplementary EDAX analyses.

Figure 4 provides examples of the initial and final surface finishes (obtained for SEM replicas).

Figure 4 : Microscopic examinations of initial and final surface made on replicas of In. 600 from DA 1 (replacement S.G.)

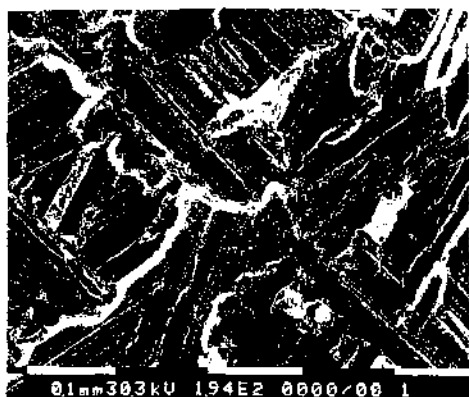

Before electropolishing (x195)



After electropolishing (x503)

4. CONTAMINATION RESULTS : field results at NOGENT 2

In July 1990 during the first refueling outage after one operating cycle deposited activity and dose rates measurements were made.

The in situ deposited activity measurements were carried out by the CEA CADARACHE directly inside the steam generator with the Emec equipment (measurements and studies of circuit's contamination). Gamma scanning spectra data were obtained on the hot leg of the S.G.C.H. n° 3. The results obtained after processing by a micro-computer are given on table 2 for Co⁵⁸ and Co⁶⁰.

Table 2 : Deposited activity measurements at NOGENT 2 (GBq/m²)

Surface	State	Co ⁵⁸	Co ⁶⁰
clad bowl	non electropolished	10	0.9
	electropolished	2	0.4
partition plate	non electropolished	6	0.5
	electropolished	0.9	/

The electropolishing of the steam generator channel head clearly leads to a considerable reduction of activity specially that due to Co⁶⁰.

The contributions from the partition plate and the bowl to the total dose rate have been calculated in case of a electropolished S.G.C.H. or a non electropolished S.G.C.H. Thus electropolishing leads to a reduction of 44 % of the total dose rate compare to a non-electropolished channel head.

This beneficial effect was confirmed by the dose rate measurements obtained during the latest refueling outage :

Total average : 21.8 mSV/hour

Taking into account the total average channel head dose rates at NOGENT 1 after one cycle (39.0 mSV/hour) at NOGENT 2 the approximate dose rate reduction should be about 45 %.

5. CONCLUSIONS

French electropolishing experience has been very satisfactory to date.

The improvement of the S.G.C.H. surface finish by electropolishing leads to a significant reduction of the dose rate level.

After one fuel cycle in one plant, a decrease of 45 % in the dose rate from the steam generator channel head was obtained.

These results have encouraged EDF to electropolish all new S.G.C.H. including steam generator replacements.

Electropolishing will also be realized on site and in FRAMATOME manufacturing facilities.

6. REFERENCES

- [1] Influence of electropolishing on corrosion product deposition. A. BRISSAUD - B. LANTES - P. SAURIN - P. BESLU - Berkeley 16-18/03/1988
- [2] French experience with electropolishing (1) P. SAURIN - C. WEBER - Berkeley 16-18/03/1988.
- [3] French experience with electropolishing (2) P. SAURIN - C. WEBER - A. BRISSAUD - G. GOUILLARDOU Bourmemout h 23-29/10/1989.

DEMANTELEMENT DE L'INSTALLATION DE RETRAITEMENT AT.1 DE
LA HAGUE

C. LAFFAILLE UDIN / LA HAGUE
CEA - DCC/DERD/UDIN/LA HAGUE

DISMANTLING OF AT1 REPROCESSING PLANT AT

LA HAGUE

1 - PREAMBULE

L'installation AT.1 était l'atelier pilote de retraitement des combustibles des réacteurs surgénérateurs (Rapsodie - Phénix). Elle a fonctionné 10 ans de 1969 à 1979 et a produit 1094kg de U/Pu.

L'atelier comportait initialement trois cycles de retraitement. Un quatrième cycle de séparation U.Pu et un stockage supplémentaire de produits de fission furent créés ensuite dans le bâtiment extension mis en actif en 1972. La mise à l'Arrêt Définitif en 1979 fut suivie :

- d'une période de rinçage d'un an qui permit de récupérer 600g de Pu et 1 700 g de U ;
- d'une période de décontamination de dix-huit mois.

L'UDIN prit en charge l'installation le 1er janvier 1982. Les études préliminaires avaient commencé en avril 1981 et le dossier de sûreté fut présenté aux Autorités le 30 juin 1982. Les éléments combustibles étaient retraités dans l'atelier AT.1 selon le procédé PUREX. Les différentes fonctions étaient réparties dans une succession de cellules (voir figure).

L'objectif des opérations dans l'atelier AT.1 est de réaliser un déclassement de niveau 3, hors génie civil, c'est-à-dire consistant à :

- démonter et évacuer tous les circuits et équipements contaminés
- assainir les locaux au niveau le plus bas possible pour permettre une réutilisation du bâtiment sans contrainte de surveillance permanente.

Le scénario de démantèlement a été établi en fonction des difficultés d'intervention dans les différentes cellules et des moyens à mettre en oeuvre en conséquence. Les principales étapes sont les suivantes (voir tableau) :

- 1 : démantèlement des cellules et boîtes à gants alpha et des cellules non irradiantes.
- 2 : démantèlement des cellules irradiantes aisément accessibles
- 3 : démantèlement des cellules Haute Activité en béton.
- 4 : démantèlement des cellules de stockage.
- 5 : assainissement final de tous les locaux.

2 - DEMANTELEMENT DES CELLULES ALPHA

Le démantèlement des cellules alpha et des boîtes à gants qui ne présentaient qu'un très faible niveau d'activité gamma a été effectué en intervention directe. Toutefois, on a recherché à atteindre les meilleures conditions d'étanchéité pour la protection des travailleurs et de l'environnement. Dans ce but un système d'atelier modulaire a été développé permettant de s'adapter aux formes des cellules et des locaux. Des panneaux en acier inox de dimensions standart sont assemblés entre eux pour constituer les murs et le toit. Un joint polymérisant classique assure l'étanchéité entre les éléments. La forme des panneaux est conçue pour présenter une face interne lisse de manière à ne pas retenir la contamination. Un ensemble de modules de ventilation complète le dispositif. Le premier a été réalisé pour le démantèlement de la cellule 906 (fin de procédé) et des boîtes à gants de laboratoire. A cette occasion un système de scaphandre personnel, ainsi qu'un dispositif d'évacuation étanche des déchets ont été expérimentés.

3 - DEMANTELEMENT DES CELLULES HAUTE ACTIVITE

La stratégie du démantèlement de ces cellules répond aux principes suivants :

- * intervention dans les cellules par le haut ;
- * machine de démantèlement mobile et disposant de son propre confinement et d'un poste de maintenance ;
- * système indépendant d'évacuation de déchets vers un atelier de conditionnement ;
- * toutes les opérations effectuées sans rupture du confinement ni de la protection biologique.

La machine de démantèlement ATENA a été conçue pour le démantèlement en téléopération des cellules d'AT.1. Elle se compose d'un porteur et d'un télémanipulateur (MA 23 M ou RD 500).

Le porteur comprend :

- une hotte de confinement,
- un chariot de transfert,
- un bras constitué d'une partie à déplacement vertical et d'une partie polyarticulée supportant le télémanipulateur.

La machine ATENA se déplace sur des rails au-dessus des cellules 904-905. La conduite s'effectue à distance en vidéo. Une nouvelle protection biologique mise en place au-dessus des cellules 904-905 comporte des ouvertures par lesquelles le bras porteur et son télémanipulateur peuvent être introduits en cellule sans rupture de confinement. L'étanchéité est assurée par un opercule de travail amené au poste de travail choisi. Un opercule de maintenance assure le confinement d'ATENA au poste de maintenance à l'extrémité sud de la zone de travail. Sous la protection biologique circule un chariot équipé de deux palans destinés à l'élingage des pièces lourdes et à l'évacuation des déchets vers un atelier de conditionnement.

L'outillage de démantèlement utilisé avec ATENA est intégré dans des boîtes à gants amovibles qui permettent l'introduction et le supportage des outils en cellule et également leur maintenance hors cellule.

Pour la cellule 903 (dissolution), il a été nécessaire d'effectuer une brèche dans le mur de séparation permettant le passage du polyarticulé d'ATENA. La découpe du béton a été réalisée à l'aide d'une scie à disque diamanté montée sur la machine ATENA. Le refroidissement était effectué par azote liquide.

4 - EVACUATION DES DECHETS

Tous les déchets issus du démantèlement d'AT.1 sont contaminés par des radioéléments émetteurs alpha provenant des composés du Pu. En outre, les déchets issus de la tête du procédé sont contaminés par des émetteurs bêta-gamma provenant des produits de fission.

En France les normes interdisent le stockage en surface ou à faible profondeur de déchets ayant une concentration en émetteurs alpha supérieure à 3,7 GBq/t (0,1 Ci/t). Toutefois la présence d'émetteurs bêta-gamma dans les déchets d'AT.1 ne risque pas d'être une contrainte vis-à-vis des normes de stockage. On doit seulement vérifier que les colis ne présentent pas des débits de dose supérieurs à 2 mSv au contact.

La plupart des déchets issus d'AT.1 font donc l'objet d'une mesure de concentration en émetteurs alpha à l'aide d'une station de comptage utilisant la méthode dite "globale" basée sur la détection des neutrons dus aux fissions spontanées et aux réactions alpha, n.



TABLEAU RECAPITULATIF DES OPERATIONS DE DEMANTELEMENT

	Cellule	Type	Risque radiologique dominant	Technique opératoire	Outillage principal	Dose Intégrée mSv	Masse (tonne) et Activité (GBq) des déchets
Etape 1	906	Cellule α	Contamination importante	Intervention directe en atelier modulaire ventilé	Cisailage hydraulique	non	36
	950/951 Bag. Labo	Boîtes à gants	Contamination importante	Démontage local et transfert pour démantèlement dans l'atelier de 906 (ci dessus)	Cisailage hydraulique	significative	1350
	952	Cellule α	Contamination importante	Intervention directe en atelier modulaire ventilé	Cisailage hydraulique	non significative	33 253
	920	Cellule béton	Contamination αγ superficielle	Intervention directe en cellule décontamination des tôles après découpe par électro-décontamination	Torche à plasma	non significative	20 37
Etape 2	Cellule filtration	Cellule inox blindage plomb	Points chauds très irradiants	Découpe des tuyauteries de liaison extraction de la boîte inox sous protection du plomb de la cellule	Outil spécial de découpe	28	42 173
	911	Cellule blindée	Points chauds irradiants	Confinement en panneaux modulaires - intervention sous protection d'écrans.		11,5	94 181
	907 BIS	Cellule inox blindage plomb	Points chauds irradiants	Intervention en direct à l'intérieur de l'enceinte après extraction des points chauds	Cisaille torche plasma	19	12 100
Etape 3	901 - 902	Cellule béton peau inox	Points chauds très irradiants	Intervention directe après mise en place d'écrans en téléopération	Torche plasma	115	16 25
	904 - 905	Cellule béton brut fêche-frite inox	Contamination βγ ambiance irradiante importante	1. Evacuation des dalles de toit remplacées par une protection allégée 2. Démantèlement en téléopération à l'aide de la machine ATENA et du télémanipulateur MA23 3. Conditionnement des déchets en téléopération dans une cellule spécifique 4. Achèvement en direct du démantèlement de 905	Tronçonneuse à disque Cisaille hydraulique Cisaille hydraulique	26 15 (estimation) (avec 903)	97 26 50 500 (estimation) (avec 903)
	903	Cellule béton brut fêche-frite inox	Contamination βγ ambiance irradiante importante	1. Découpe du mur 904/903 à l'aide de la machine ATENA 2. : 3. : Voir 904	Scie à disque diamanté	7,5 Voir 904	21 23 Voir 904
Etape 4	908 - 909	Cellule Béton brut fêche-frite inox	Points chauds irradiants	Découpe des cuves à l'explosif pour réduction du temps d'intervention	cordons détonnants	22	9 24
	917	Cellule béton brut fêche-frite inox	points chauds irradiants	Intervention directe écrans blindés si nécessaire			Démantèlement non effectué

DECONTAMINATION PROCESSES APPLIED DURING DA1 S.G. REPLACEMENT

Authors : Y.M. BEISSIERE - B. LANTES - EDF
P. SAURIN - C. BRUN - FRAMATOME
P. BESLU - CEA

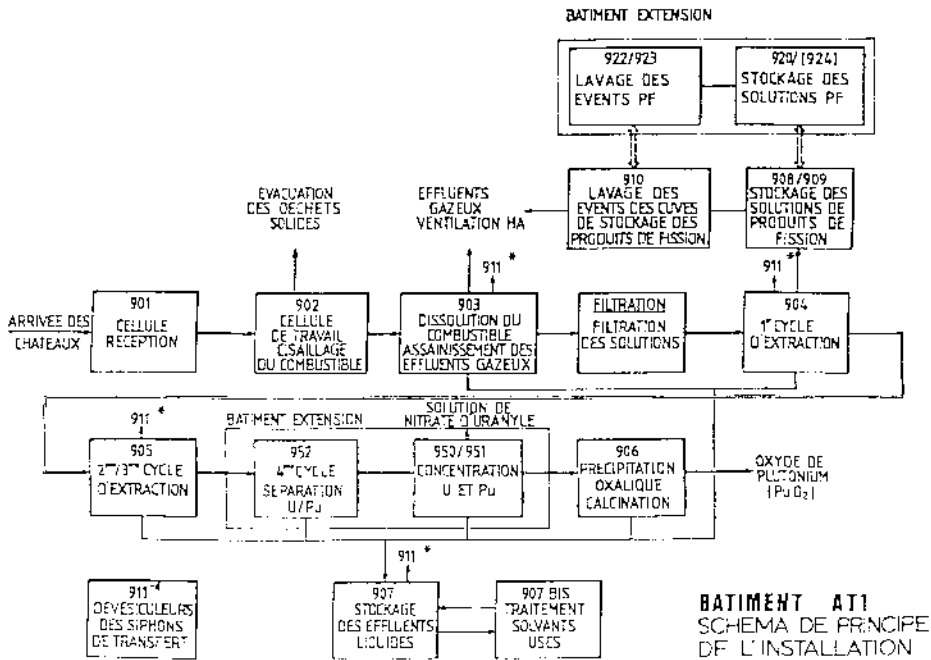
ABSTRACT

In support of the ALARA concept, applied to the DA1 SGR operation, EDF decided to decontaminate at least the primary pipes and elbows of each primary loop. For the 1st and the 2nd loops an electrodecontamination process was applied after steam generator removal. For the 3rd loop a soft chemical decontamination was also performed in the channel head using the LOMI process.

INTRODUCTION

The steam generators replacement on the DAMPIERRE 1 (DA1) nuclear power plant in 1990 (900 MWe with 3 loops PWR) was the first such operation performed in FRANCE.

- Decontamination had two purposes for DA1 (ALARA concept) :
- to lower the radiation level around the RCS elbows, thus to reduce overall radiation exposure,
 - to remove contamination from the RCS elbows surfaces, to allow easier working conditions in SG cubicles.

In order to achieve these goals the minimum DF demanded was 8 and no free remaining contamination was allowed.

PREPARATIONS AND QUALIFICATION OF THE PROCESSES

Preparative studies were carried out over three years before 1990 operation. Several processes were evaluated ; various soft chemical decontamination processes, electrodecontamination and sand blasting. Two processes were retained, the LOMI process as soft chemical decontamination and electrodecontamination method using phosphoric acid.

LOMI chemical decontamination

As shown on fig. 1, chemical decontamination was simultaneously applied in channel head and primary pipes. In order to avoid introducing chemicals into the reactor vessel, inflatable stoppers were developed to withstand the conditions required by the process. The LOMI process, for which FRAMATOME acquired the license in 1987, was finally chosen because, it was proved to be efficient, non-corrosive, compatible with the inflatable stoppers and less risky in terms of temperature and pressure required.

Electrodecontamination process

The preparation work consisted in the complete design of :

- The electrodecontamination process, mainly the selection of the electrolyte, and operation parameters such as time, temperature, current density, suckers velocity ...

- and, simultaneously, the tools required to apply the decontamination process on primary pipes ends (cast elbows and stainless steel primary pipes).

Electrodecontamination basic principle was derived from well mastered electropolishing of SG channel head, with suction cups as shown in fig. 2.

Figure 1 : Implementation of chemicals and stopper

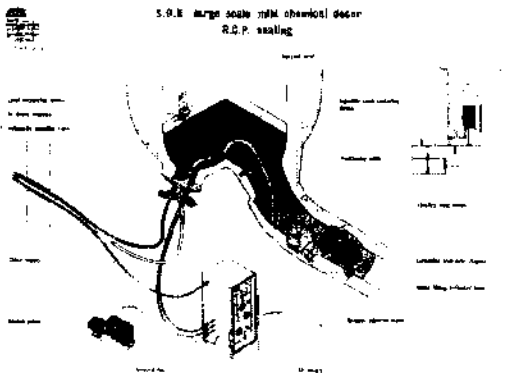
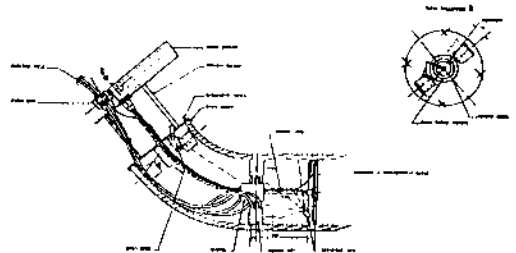

Figure 2 : Tooling for electrodecontamination (Barras/Provence/STMI patented)



Tooling

Electrodecontamination of the pipe ends is applied after the steam generator has been removed. A specially designed carrier is mounted on the free end of primary pipes. It runs along a central rail fixed on the pipe end and is centered by a plug equipped with an inflatable ring located inside the primary pipe. This carrier supports a set of two leaktight suction cups applied on the RCS pipe walls and arranged symmetrically to decrease the force on the carrier.

The carrier drives both the continuous forward motion and rotation for the suction cups. Nominal displacement of the suckers comprised 2 passes (go and return) and rotation was achieved by a pitch equal to the diameter of cups. 15 stripes were planned to be performed by each cup.

DAMPIERRE 1 DECONTAMINATION OPERATIONS

The soft chemical decontamination was the first main steam generator replacement step. It started on march 8, 1990 on steam generator n° 3. Electrodecontamination started on march 26 for primary loop n° 1 since steam generators had to be first removed from their cubicles.

LOMI decontamination on SG n° 3

The main characteristics of the process used in DAMPIERRE were :

- 4 main steps O.R.O.R.
- Temperature 90° C

- Main steps duration O = 10 h - R = 8 h
- The oxidizing solution was stored temporarily in a buffer tank ready for reuse.
- 1st reducing step "decontaminated" by passing through cationic resins.
- Liquid effluents transported by trucks out of the plant for solidification.

Circulation and heating of solutions, resin treatment, chemical injection ... were performed by modular skid installed in the adjacent fuel building ; the reagents were routed through flexible hoses between the reactor building and fuel building. The tooling package consisted in two compact modules, two temporary storage tanks, and a laboratory skid.

The decontamination team was composed of 18 operators and 4 chemists for process control. The operation lasted the 8 days (3 shifts a day) scheduled. Total man-sievert dose to the deconteam was 0.055 man-sievert. Approximately 110 G.Bq were removed. Initial dose rates observed on DA1 RCS were very low (table 1) due to careful plant shut down and to purification of primary coolant.

Table 1 : Dose rates (arithmetic mean) m sievert/h
External contact of pipes

	INITIAL DOSE RATES (8 pts)	FINAL DOSE RATES (8 pts)	DRRF
Cold leg	0.413	0.027	15
Hot leg	0.253	0.022	11.2

The main results obtained were :

- Average dose rate reduction factor : 13.3 for 8 guaranteed.
- Decontamination factor (as ratio between initial surfacic contamination and final surfacic contamination measured by external γ probe collimated) :
 - Hot leg : DF = 30
 - Cold leg : DF = 70
- The average dose rate inside the cubicle was 0.05 m.sievert/h after steam generator removal.

Electrodecontamination on loops n° 1 and n° 2

The electrodecontamination tooling i.e, the carrier and its suction cups, the I and C cabinet and the electrolyte vats formed a self-contained unit installed in the reactor building at 4.6 m level for the vats, at 8 m level for the control cabinet in the containment annulus and at ground level for effluents storage. The electrodecontamination team was composed of 5 FRAMATOME supervisors and 27 operators and inspectors for STMI who operated the decontamination.

The decontamination operation lasted 100 h for loop n° 1 compared to 50 h scheduled and 70 h in the loop n° 2 for 50 h scheduled.

The decontamination team integrated dose after the decontamination of the two loops was 90 mSV (9 man-rem).

The average (arithmetic) dose reduction factors are shown in table 2 and 3 (m sievert/h)

Table 2 : DRRF before chamfer machining

Loop n° 1	Initial dose rate	Final dose rate	DRRF
Cold leg	0.457	0.030	
Hot leg	0.265	0.025	
Arithmetic mean	0.361	0.0275	13.1

Table 3 : DRRF after machining

Loop n° 1	Initial dose rate	Final dose rate	DRRF
Cold leg	0.457	0.027	
Hot leg	0.265	0.017	
Arithmetic mean	0.361	0.022	16.1

Loop n° 2	Initial dose rate	Final dose rate	DRRF
Cold leg	0.432	0.052	
Hot leg	0.252	0.020	
Arithmetic mean	0.342	0.036	9.5

4. CONCLUSION

Both decontamination processes were used in DAMPIERRE 1, because the first SGR operation was considered as a "bench test" for future similar operations.

- the goal was completely reached with soft chemical decontamination (dose rate reduction, working conditions in SG cubicles, experience)
- the goal was partially reached with electro-decontamination (dose rate reduction, experience) and improvement are already engaged to obtain clean working conditions.

The DRRF were similar (approx 13 in both cases) and this result was considered as successful, especially taking into account the low initial doses rates. The total man-SV saved by decontamination was estimated to be 0.5 man-sievert (50 man-rem) (i.e., 25 % of total integrated dose).

**La NORMALISATION INTERNATIONALE
un OUTIL pour la RADIOPROTECTION**

The international cooperation for standardization in the field of electrical industries was founded in 1904 to promote world wide compatibility and interchangeability of goods. Standardization is considered today as a suitable tool for radiation protection both nationally and internationally. To date more than 50 IEC and ISO standards are in use throughout the world and approximately 50 drafts standards are in the various phase of elaboration and publication. For the future, IEC and ISO have decided to have a close cooperation in order to harmonize and accelerate their work, for the benefit of the energy production and the environmental protection.

L.FITOUSSI

Président du CEI/TC45/SC45B "Instrumentation de
Radioprotection" et de l'ISO/TC85/SC2 "Radioprotection"

Origine et assise de la normalisation internationale

C'est au congrès international d'électricité qui se tenait en Septembre 1904 à Saint Louis (USA) que naquit l'idée de la normalisation internationale. Les savants et les industriels de l'époque souhaitaient une large coopération des sociétés techniques du monde en vue de créer une commission permanente pour servir de forum à une concertation et à une collaboration continue. Ils prévoyaient qu'ils pourraient, par l'entremise de cet organisme, élaborer des solutions communes, appelées depuis "normes internationales", à des problèmes qui, s'ils n'étaient pas résolus rapidement, pouvaient dans le futur conduire certainement à la confusion et créer des entraves et des barrières techniques!

Près de quatre vingt dix ans ont passé et l'esprit visionnaire de ces fondateurs se perpétue aujourd'hui au travers de deux grands organismes mondiaux de normalisation que sont d'une part la CEI (Commission Electrotechnique Internationale), et d'autre part l'ISO (Organisation Internationale de Normalisation) créées respectivement en 1906 et D'autres organismes ont une mission similaire sur le plan régional comme le CEN (Comité Européen de Normalisation) créé dans le cadre de la Commission des Communautés Européennes.

Les normes, outils d'intercomparaison et de décision

S'il n'est plus nécessaire de rappeler l'importance des normes techniques pour les marchés nationaux et internationaux, il est indispensable néanmoins de souligner le rôle primordial des normes internationales de radioprotection relatives à la surveillance de l'environnement. C'est le cas notamment de celles qui concernent les techniques de prélèvement et de mesure applicables, aux opérations de surveillance radiologique des rejets des effluents, aux vérifications des conteneurs de trans-

port de matières radioactives, et aux contrôles des produits de la chaîne alimentaire.

Cependant la normalisation internationale en radioprotection trouve plus particulièrement sa résonnance dans le cas de la gestion des situations de crises provoquées par les accidents nucléaires. En effet, seules des normes, largement adoptées par la communauté scientifique et technique mondiale, peuvent être un outil efficace d'intercomparaison, de dialogue et d'aide à la décision à la disposition des autorités réglementaires. De telles normes peuvent être, en outre, considérées comme un moyen efficace et incontournable de rassurer le public sur la qualité et la crédibilité des mesures et l'authenticité des informations diffusées.

Les domaines couverts par la normalisation en radioprotection

Les partenaires de la normalisation en radioprotection, chercheurs, concepteurs, fabricants, utilisateurs, ont depuis près de trente années œuvré, tant à l'ISO qu'à la CEI, pour publier plus d'une cinquantaine de normes techniques de radioprotection. A celles-ci il faut ajouter, à ce jour, plus d'une dizaine de normes en cours d'édition et une quarantaine de projets en cours d'élaboration.

Toutes ces normes représentent un ensemble cohérent de documents techniques portant sur:

- la terminologie (grandeurs, unités, symboles etc..)
- les rayonnements de référence pour les tests de qualification et l'étalonnage des appareils de mesure,
- la conception des matériels et des sources ainsi que les moyens de protection technique tels que les blindages, les revêtements, les filtres, les appareils respiratoires, etc...
- les méthodes et les appareils de surveillance:
 - . des expositions et des contaminations

individuelles,

- . des niveaux d'irradiation et de contamination aux postes de travail dans les installations,
- . des niveaux d'exposition et de contamination dans l'environnement en situation normale et en situation accidentelle et post-accidentelle.

Les approches et les choix de la normalisation

Le choix des sujets à normaliser ne s'est pas fait au hasard. Il a souvent répondu en priorité aux besoins des utilisateurs. C'est ainsi que l'abandon en radioprotection de la grandeur "exposition" c'est à dire de l'unité "roentgen" et l'adoption du concept de "dose absorbée" préconisé par la CIUR (Commission Internationale des Unités Radiologiques) et la CIPR (Commission Internationale de Protection Radiologique) a nécessité l'élaboration de nouvelles normes.

De même des événements marquants comme les accidents de TMI et de Tchernobyl ont conduit à concentrer les efforts sur la normalisation des techniques de surveillance du milieu et de la chaîne alimentaire. Aujourd'hui, alors que les problèmes liés à la radioactivité naturelle ont pris place sur le devant de la scène internationale, plusieurs normes relatives à la mesure du

radon et ses descendants sont en chantier pour répondre aux préoccupations des services sanitaires.

Aux premiers temps de la normalisation en radioprotection les partenaires concernés se sont entendus pour conforter et rendre cohérentes les options techniques relatives aux appareillages et aux méthodes existantes et déjà largement diffusés. De nos jours ces mêmes partenaires, confrontés à une technologie plus récente, souvent en évolution ou même en cours de développement, s'efforcent d'orienter les choix des spécifications techniques des appareillages vers des solutions communes et réalistes.

Cette nouvelle approche de la normalisation est aujourd'hui nécessaire pour éviter l'écueil de la dispersion des options techniques. Elle permet d'exiger un degré optimal de performance, de qualité et de fiabilité, tout à fait satisfaisant pour la grande majorité des utilisateurs, et par là, répond aux critères de base pour les appareillages devant être mis sur le marché international. Cette nouvelle attitude des "normalisateurs" n'est surtout pas contradictoire avec une certaine flexibilité ou liberté quand aux choix des procédés techniques de réalisation. C'est tout particulièrement le cas aujourd'hui des normes, en cours de préparation, sur les dosimètres électroniques de poche pour la mesure des doses individuelles dues aux rayonnements photoniques et neutroniques.

Le contenu des normes de radioprotection

Chacune des normes, établie à partir de spécifications précises et acceptées par tous les partenaires concernés, représente le meilleur compromis entre la qualité de la mesure, la conception et le coût de la méthode ou de l'appareil. Les textes rédigés en français et en anglais sont soigneusement examinés par un comité de rédaction afin d'obtenir des documents clairs, directement compréhensifs par tous et présentés suivant un format type de façon à couvrir tous les aspects relatifs à la conception, au fonctionnement, et à la sécurité.

En elles-mêmes les normes internationales contiennent donc tout ce qui paraît nécessaire pour assurer un niveau suffisant de performances et de qualité des méthodes et des appareillages. Par exemple, les normes techniques de radioprotection établies par la CEI traitent généralement des points suivants:

- domaines d'application et d'utilisation spécifiques de l'appareillage décrit dans la norme,
- terminologie adoptée pour la norme,
- caractéristiques conceptuelles et fonctionnelles,
- caractéristiques électriques et mécaniques,
- caractéristiques de sécurité et d'environnement,
- conditions normales d'utilisation et performances des mesures pour les rayonnements de référence,
- réponse de l'appareil aux grandeurs d'influence physiques (effet des variations de température, pression, humidité, champs électriques et magnétiques, chocs etc...) et radiologiques (effets dus à la nature et à l'énergie des rayonnements parasites...),

- description des méthodes d'essai pour vérifier les performances de mesure, et prescriptions minimales pour le respect de la norme.
- documentation technique liée à chaque appareil.

La normalisation aujourd'hui et demain

Aujourd'hui plus de 80 pays sont membres des organisations internationales de normalisation et plus de 20 pays participent plus ou moins activement à l'élaboration des normes de radioprotection. La plupart des pays engagés dans le développement de l'énergie nucléaire, la recherche et l'utilisation industrielle et médicale des rayonnements, ou de la radioactivité, s'appuient dans de nombreuses occasions sur les normes de l'ISO et de la CEI. Ainsi plusieurs pays se servent des spécifications techniques des normes comme prescriptions de base pour leurs documents commerciaux tels que les appels d'offres.

En France les normes de la CEI sont utilisées comme documents de référence pour les essais de qualification et d'homologation des appareillages de radioprotection mis en oeuvre dans les installations du Commissariat à l'Energie Atomique.

Même si la plupart des pays ne tirent, qu'à posteriori, largement profit des documents techniques, que sont les normes une fois publiées, il faut par surcroît faire ressortir le rôle des réunions internationales des comités, sous comités et des groupes de travail. Celles-ci sont aussi l'occasion d'échanges directs d'informations scientifiques et techniques. En effet les discussions qui se déroulent au cours de l'élaboration des normes contribuent certainement et activement aux transferts de technologie, ce que l'on peut considérer, à juste titre, comme un moyen international d'accroître la sécurité mondiale.

Pour l'avenir les organisations internationales de normalisation ISO et CEI ont fait part de leurs préoccupations majeures qui sont:

- d'une part l'estimation et la planification des besoins pour les travaux futurs de la normalisation internationale. Ceci en vue d'apporter une aide efficace au développement industriel dans des secteurs clés comme la production énergétique et la protection de l'environnement. A cet effet l'ISO et la CEI préconisent une accélération des travaux et insistent sur la production en temps voulu de documents normatifs courts mais précis, susceptibles le cas échéant d'être mis en révision peu après leur publication.

- d'autre part le développement d'une stratégie à long terme permettant d'associer plus étroitement les capacités et les compétences de ceux qui oeuvrent pour la normalisation internationale, et ce, en vue de répondre aux défis techniques et économiques de demain. C'est ainsi que les deux grands organismes ISO et CEI ont déjà définis leurs objectifs en créant des moyens permanents de concertation et en adoptant des procédures de travail communes et harmonisées. En outre des accords de coopération technique ont été conclus avec les organismes européens de normalisation. Tout ceci pour la mise en oeuvre de la devise:

" Faites-le une fois, faites-le bien, faites-le sur le plan international !"

THE ROLE OF THE IAEA ON THE CONTROL AND SAFE USE OF RADIATION SOURCES

J.U. Ahmed
Division of Nuclear Safety
International Atomic Energy Agency
Vienna

Abstract: Radiation sources are widely used all over the world with an increasing trend. Although safety records are claimed to be high, bad accidents with radiation sources have happened, resulting in injury or death to persons. Organized systems of safety and radiation protection for radiation sources are strikingly deficient both at national and international levels. The IAEA, in response to the demand from many Member States, has initiated a programme since 1988 on the control and safe use of radiation sources with the aim to develop and disseminate internationally harmonized regulatory and technical guidance for the control and safe use of radiation sources.

1. Introduction

Public concern about the safety and regulatory control of radiation sources has grown over the past few years particularly following some bad accidents that happened with both industrial and medical radiation sources. The most notable one is that of Goiania in Brazil in 1986 where an accident with medical irradiation source caused death of a number of innocent public including children (1). In Mexico, in 1983, a medical cobalt teletherapy source was declared as a scrap and was sold to a steel manufacturing company which melted this source together with tons of steel and manufactured furniture parts which were exported to the United States of America. There were no casualties in that accident but the logistical consequence was enormous (2).

Over the past 15 years there has been a number of accidents with industrial irradiation sources, for example, in Italy in 1975 (3). Norway 1982 (4), El Salvador in 1989 (5), and Israel in 1990 (6). High radiation exposures resulting from these industrial accidents caused severe radiation injuries which led to death of four operators and amputation of limbs of the fifth one. The question arises as to who were at fault, the designers, manufacturers, regulators or operators? Another question naturally arises as to what measures were missing which could have prevented such accidents?

2. Estimation about radiation sources

Some estimation made by the IAEA about radiation sources reveals large number in use throughout the world (Table). Also, estimates have been made of the magnitude of annual number of shipments of radioactive sources in 20 countries. These shipments cover all kinds of sources. The data are considered incomplete and inaccurate but it is believed that the actual number of shipments could be well over 10 million per year.

TABLE. SOME DATA ON RADIATION SOURCES

TABLE. SOME DATA ON RADIATION SOURCES

<u>SOURCE</u>	<u>NUMBER</u>	<u>WHEREABOUTS</u>	<u>SOURCE-STRENGTHS AVERAGE</u>	
Teletherapy sources	2600	worldwide	Co-60 Cs-137	220 TBq 40 TBq
Brachytherapy sources	30000 100000	USA worldwide	20 MBq - 4 GBq	
Radiography units	3500 25000	USA worldwide	Ir-192 Co-60	4-11 TBq 1.5 TBq
Commercial product irradiators	150	worldwide	Co-60 Cs-137	40000 TBq 400000 TBq
Industrial gauges	90000 500000	USA worldwide	--	--

3. Nature of the Problem

The IAEA operates through the national atomic energy organization in its Member States. However, radiation sources used in a country are not all procured through this organization. In most cases radiation sources used in industry, medicine, agriculture, and education are procured through the administrative channels of the relevant authorities. In other cases the user imports them directly from the supplier or the manufacturer (2). There are also cases where foreign companies operate industrial irradiation sources which are brought directly without channeling through the concerned national authorities (7). In many developing countries the national atomic energy organization, may not have any knowledge of all radiation sources or their locations of use. This is mainly because there are no established radiation protection infrastructures. The IAEA Radiation Protection Advisory Team missions revealed that 38 developing Member States have no radiation protection law in force and 50 Member States have inadequate radiation protection standards and/or infrastructures.

4. IAEA programme

4.1. Activities prior to 1988

By recognizing the radiation safety problems, the Agency in 1988 initiated a new programme on the control and safe use of radiation sources. This should not, however, imply that before 1988 the IAEA did not have any programme on the standards of safety and protection. The Agency since 1957 initiated a programme on radiation protection with the objective to ensure safe operation of radiation sources, nuclear installations and the protection of man and his environment from the harmful effects of radiation and radioactive releases. The major functions are the development of safety standards, safety guides, recommendations on practical procedures and also some operational service.

The IAEA Basic Safety Standards for Radiation Protection, issued in 1967 was revised jointly with WHO, ILO, and OECD/NEA in 1982 (Safety Series No.9). Following 1990 recommendations of the ICRP the IAEA initiated the revision of the Basic Safety Standards for Radiation Protection jointly with WHO, ILO, FAO, OECD/NEA and Pan American Health Organization, with a plan to publish it in 1993. Prior to 1988 the IAEA initiated two safety series documents related to the control of radiation sources: Safety Series No.101 on Operational Radiation Protection and Safety Series No.102 on the Recommendations for the Safe Use and Regulation of Radiation Sources in Industry, Medicine, Research and Agriculture, both published in 1990.

4.2. The programme initiated in 1988

There are three projects under this subprogramme namely, control and safe use of radiation sources, information on irradiation sources and application of the probabilistic safety criteria. The first task was the revision of the already existing Safety Series No.1 on Safe Handling of Radionuclides, by combining Safety Series No.20 on Safe Handling of Radioisotopes in Hydrology, Safety Series No.23 on Radiation Protection Standards for Radioluminized Time Pieces, and Safety Series No.40 on Safe Use of Radioactive Tracers in Industrial Processes. This combined document, now ready for publication, will serve as a parent document in the whole series of guides issued in the area of the control of radiation sources. One task initiated in 1989 is on regulatory guidance to assist and advise Member States on how to prepare the regulatory infrastructure and regulatory provisions for the control of radiation sources and a document will be published in the near future.

Radiation protection in hospitals is one important subject which was dealt with jointly by IAEA, WHO and ILO since many years. Five documents on this subject area were published jointly in 1970s. This time the Agency has taken the initiative to revise these documents jointly with ILO, WHO, FAO, OECD/NEA, and PAHO with a plan to publish the revised documents in 1993. Radiation safety aspects of specific uses of industrial and medical radiation sources is an important component of the activity under this programme. Six documents have been already prepared which are under publication and these are: Practical Radiation Safety Manuals on (1) Shielded Enclosures, (2) Gamma Radiography, (3) Nuclear Gauges, (4) High Energy Teletherapy, (5) Brachytherapy and (6) Therapeutic Uses of I-131.

Development of complementary resource materials for various technical documents, radiation protection principles for the handling and disposal of radiation sources no longer in use, development of guidance material for information of the public and standardization of international marketing system for sealed sources are the other on-going activities. Other activities are publication of a bulletin or news letter on the safe use of radiation sources, development of database on radiation sources and devices specifications, database on radiation accidents and publication of reports, exchange of practical regulatory information applicable to the control of radiation sources, co-ordinated research programme on the safety problems associated

with the design and CRP on radiation doses in diagnostic radiology and methods of reduction are two important activities.

Regional training courses have been organized in order to provide the Member States with the up to date knowledge on various regulatory and technical measures for the control of radiation sources. The organization of such training courses will remain as a continuing activity.

The project on the probabilistic safety assessment techniques to improve the safety of radiation sources has two components, one on identification of data requirements for PSA and means for data collection, and the other on the preparation of a manual on use of PSA in radiation source safety.

During 1993-1994 an activity will be initiated to develop an international register for radiation sources with significantly high activities, other than unsealed sources; simultaneously, competent authorities will be urged to develop national register for radiation sources, including data base on radiation source specification. Emphasis will be given to strengthen means of providing information to Member States on radiation accidents and lessons learned from such accidents. To assist Member States in providing high standards of training to workers, and regulatory and management staff, the Agency will develop appropriate training manuals and complementary resource material for such national and international training courses. Also, the Agency is going to place emphasis on the implementation of Radiation Protection Advisory Team recommendations to ensure establishment of regulatory infrastructure in those Member States where such infrastructures are non-existent at present.

REFERENCES

1. IAEA, 1988, Radiological Accident in Goiania.
2. An Accident with Medical Teletherapy Unit, Mexico, 1983-unpublished report.
3. IAEA, 1991, Irradiation Accident at Stimos Plant, Italy. Report presented at Technical Committee Meeting, Vienna.
4. IAEA, 1991, Lessons Learned from a Radiological Accident, Norway, 1982, Report presented at TC meeting Vienna.
5. IAEA, 1990, The Radiological Accident in San Salvador.
6. IAEA, 1991, The Radiological Accident at Sor Van, Israel, 1990. Paper presented at IAEA TC Meeting.
7. Jalil, A. et al, An Overexposure in Industrial Radiography Using ¹⁹²Ir Radionuclide, Health Physics, Vol. 57, No. 2, 1989.

UIR : ORGANISATION ET PROGRAMME

MYTTENAERE C.

PRESIDENT

U.I.R. Secretariat: Rue Cardinal Cardijn, 5 B-4680 Cupeye (Belgium)

IUR : ORGANIZATION AND PROGRAMME

I.U.R. is an International Association which aims to promote radioecology by exchange of scientific information, cooperation and the support of young scientists. The organizational chart involves a Board of Council which coordinates the various regional branches headed by a Bureau. Besides this vertical structure, it exists an horizontal one constituted by a series of Working Groups headed by a leader. The I.U.R. also cooperates to international programmes such as, i.e., VAMP (IAEA) and SCOPE-RADPATH.

L'Union Internationale de Radioécologie est une organisation non-gouvernementale qui a pour but majeur de promouvoir la radioécologie par le truchement d'une meilleure connaissance du transfert et des effets des radionucléides dispersés dans l'environnement.

L'IUR, association internationale de droit belge, a été fondée en 1978. Elle ne comptait à cette époque qu'une petite dizaine de membres; à l'heure actuelle l'IUR en compte 375 appartenant à 37 nationalités.

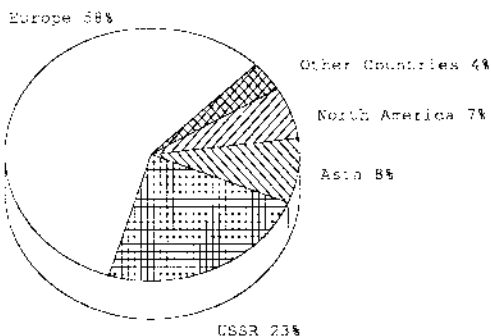

President	C. Myttenaere (Belgium)
Vice-Presidents	A.A. Cigna (Italy)
	G.G. Polikarpov (USSR)
Secretary-General	R. Kirchmann (Belgium)
Treasurer	J. Van den Hoek (Netherlands)
Officers	Cl. Bunnerberg (Germany)
	A. Grauby (France)
	B. Howard (UK)
	N. Pattenden (UK)
	Yu-Zao Qi (China)
	D. Reichle (USA)
	W. Schell (USA)
	J. Tveten (Norway)

Past Presidents:

1978-1982	P. Bovard, Honorary (France)
1982-1986	S.L. Auerbach (USA)
1986-1990	A. Aarkrog (Denmark)

L'IUR est gérée par un Conseil d'Administration comprenant 8 membres en plus du Président, des deux Vice-Présidents, du Secrétaire Général et du Trésorier. Ces membres sont élus pour 4 ans en Assemblée Générale.

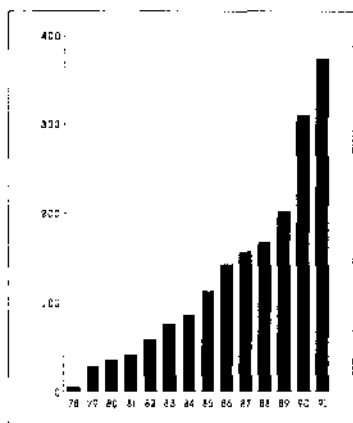

La croissance rapide de l'IUR a nécessité une décentralisation des responsabilités. Celle-ci s'est effectuée grâce à la création de Branches Nationales et Multinationales.

Les activités scientifiques de l'IUR sont soit gérées par des "Comités de Gestion", soit confiées aux divers groupes de travail. Les Comités de Gestion sont responsables des activités d'intérêt général (Ecole d'Eté, Publications,...).

Les six "groupes de travail" ont, par contre, la charge de faire le point en matière de radioécologie dans les différents domaines qui sont reprises à la figure ci-dessous.

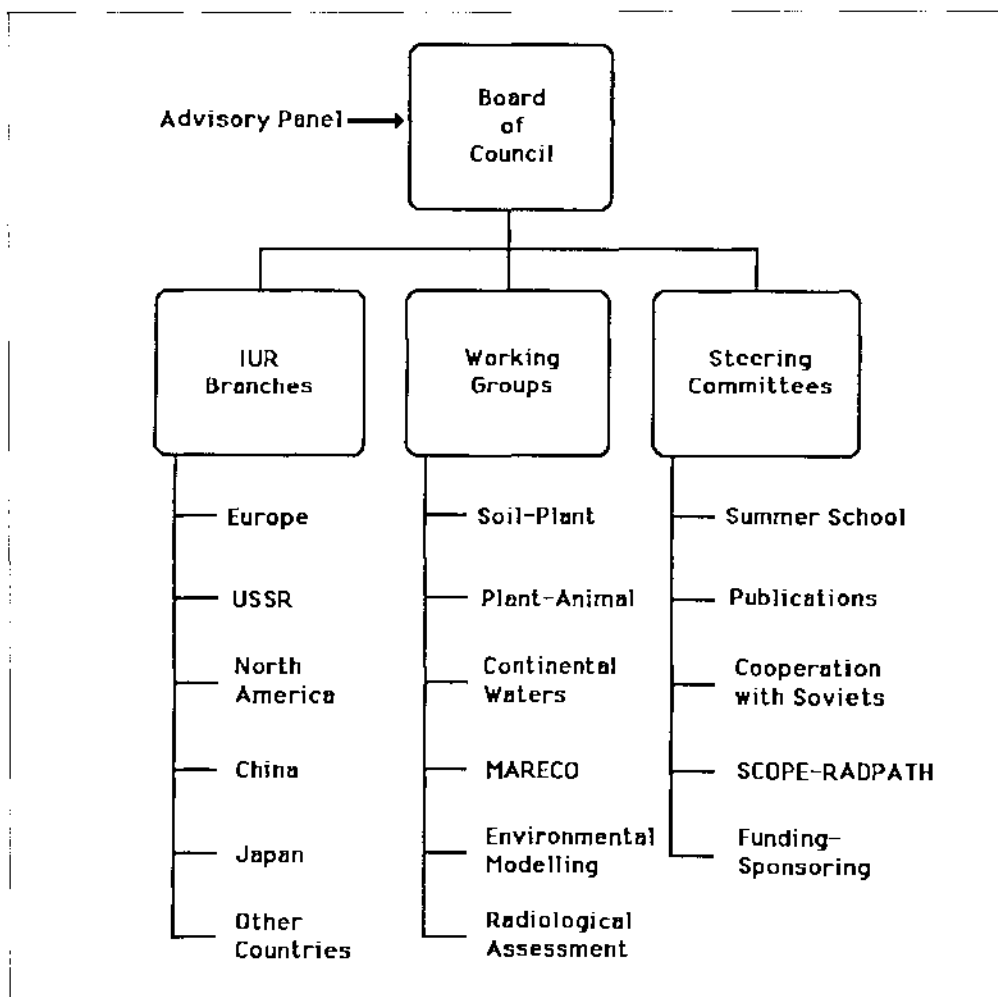

En plus de ces différentes préoccupations l'UIR aide financièrement les jeunes chercheurs, leur permettant ainsi de travailler dans d'autres laboratoires et de participer aux discussions et réunions internationales. Cette aide aux jeunes chercheurs devrait assurer une relève qui s'avère urgente et nécessaire.

En conclusion, il faut espérer que, malgré un certain désintérêt pour le nucléaire, l'étude des conséquences des diverses applications du nucléaire sur l'environnement ne tombera pas dans l'oubli. L'UIR s'y emploie et souhaite que ces activités puissent se développer grâce à un "sponsoring" plus important.

En fin d'exposé je voudrais, au nom de l'UIR, remercier les Communautés Européennes qui ont compris l'importance de ces problèmes et qui nous ont assurés de leur soutien scientifique et financier.

OPTIMISATION OF RADIOLOGICAL PROTECTION IN COMPLEX SITUATIONS

F Phillips, R W Allott and H L Wilkinson

SRD, AEA Technology,
Wigshaw Lane, Culcheth, Warrington, WA3 4NE, UK

ABSTRACT

Optimisation in radiological protection is a complex process involving trading-off conflicting objectives. A seven-stage decision-process is outlined which helps the practical implementation of optimisation.

INTRODUCTION

In radiological protection, where doses are below Regulatory Limits, decisions about the level of protection are driven by the requirement to keep doses as low as reasonably achievable (ALARA). Judgements about whether this requirement is met have been largely concerned with comparing only the cost of increased protection and the averted health detriment, traditionally using cost-benefit analysis (CBA). However, in practice, decisions to implement further protection to reduce exposure are often made for other reasons not included in the formal analysis, but which nevertheless dominate the decision. More recently, for example in ICRP 55 (Ref. 1), attention has been focused on other decision-aiding techniques, such as multi-attribute utility analysis (MAUA) and multi-outranking criteria analysis (MCOA), which can take account of more facets of the decision directly in the analytical process. This paper outlines a general decision process (similar to that in ICRP 55 (Ref. 1)) to aid the practical implementation of ALARA. Neither the decision-process nor the analytical techniques are algorithms or machines for making decisions. No process or technique can capture all the facets of a decision and the ultimate responsibility for making the decision is always with the decision-maker. The decision-process does, however, help the decision-maker understand the problem more fully, discover which facets of the problem determine the preferred option, and helps communicate to others why, and under what circumstances, a particular course of action is preferred.

THE DECISION-PROCESS

A seven-stage decision-process is outlined below. It is described in further detail in Reference 2.

Define the Problem

Having recognised that a problem exists, the first step is to precisely define the problem. This step is important and should not be underestimated since it defines what the decision is, and conversely is not, meant to address. A simple example of a problem definition is: Annual individual doses to some workers on 'plant X' are higher than 15 mSv.

Define the Aim of the Decision

This step is closely linked to the definition of the problem and focuses the decision by defining the boundary of the problem and which aspects of it are (and are not) relevant to the decision process. This is important to avoid wasting resources on generating irrelevant options and performing unnecessary analysis, and provides a formal record for future use or further study. At this point it may be necessary or helpful to incorporate any constraints

which the chosen option must satisfy. For the problem defined above the aim may be: By the use of engineered means, reduce the maximum annual individual dose to workers on 'plant X' below 10 mSv. The requirement to use engineered means represents a constraint that, for example, operational measures such as dose sharing are not acceptable.

Objective hierarchies (Refs 3 & 4) may be used to help define the aim of the decision. Using these, the decision-maker provides an overall global objective under which a hierarchy of sub-objectives is defined. Iteration of this hierarchy provides an elegant means of closely defining the aim of the decision through the use of decision objectives.

Identify Options

At this stage options must be identified which, if implemented, would achieve the desired result. The identification of options is best undertaken in a two stage process that allows less obvious solutions to emerge. First, as many options as possible should be postulated; then in the second stage, those options that are clearly unacceptable or impractical are eliminated. To avoid wasting resources it is important to reduce the number of options to a minimum whilst at the same time making sure that options are not eliminated unnecessarily. Some initial formal analysis, such as cost-effectiveness analysis (Refs 1 & 2), may help. The effort associated with any analysis must be commensurate with its likely effectiveness and with the scale of the problem.

If a decision involves choosing between options which have a range of possible outcomes (e.g. probabilistic or potential events), then it is often helpful to illustrate the problem in terms of an event type decision tree (Refs 2, 4 & 5). These set out the options facing a decision-maker and map the consequences of choosing a particular option. The act of constructing the tree can in itself clarify the nature of the problem and may lead directly to a decision. However, in complex situations this is unlikely.

Identify Relevant Attributes

Attributes (or factors) are important characteristics of the problem. The process of identifying attributes could mimic the two stage procedure for identifying options described above: firstly, all attributes of conceivable importance to the decision are identified; then, secondly, only those attributes which discriminate between options are carried forward. For example, cost is always likely to be an important attribute but if the range of costs is such that it does not discriminate between options then it has no bearing on the decision and should not be included in the decision process. Techniques of particular use in this identification process include brainstorming and the construction of objective hierarchies (Refs 2 - 6).

The refinement and structuring of relevant attributes may be achieved by the use of multi-attribute decision trees. This type of tree, developed at SRD, explicitly reflects an attribute's relative importance to the decision-maker (Ref. 4). Whereas the problem structuring techniques described above present all the relevant information, multi-attribute decision trees also encapsulate the way in which the information is brought together to model the problem by representing the relative values of the attributes and the trade-offs which must be made to reach a decision, directly in the structure of the tree.

Characterise Options in Terms of Identified Attributes

Once options and attributes have been identified, each option must be characterised in terms of the relevant attributes. The particular manner in which this is done depends on

the specific analytical technique employed, but in general involves quantifying the value of attributes for each option and the relative importance of each attribute to the overall decision. For example, in CBA the attribute 'collective dose' will be quantified in terms of manSv and converted to an equivalent monetary value (Refs 1 & 2). While in other analytical decision aiding techniques, such as MAUA, a weighting factor would be defined to express the relative value of collective dose compared to cost (Ref. 1, 2 & 7). If potential events are integral to the decision problem then quantification of probabilities will also be required (Ref. 2).

It is not always possible or desirable to include all relevant attributes in the formal analysis. Two lists of attributes should be drawn-up: the first consisting of those to be included in the formal decision analysis technique; and the second listing those not included but which must nevertheless be taken into account once the analytical solution is known. This will ensure that all the relevant attributes contribute to the final decision. At this stage it may be necessary to re-formulate the multi-attribute decision tree to reflect the attributes which are to be considered in the formal analysis.

Analytical Decision

There are many analytical techniques available to aid decision-making, ranging from simple inspection of the available options to mathematically complex methods which combine all the facets of a problem into a single measure of its overall worth. Historically, CBA has been used almost exclusively for decisions in radiation protection. More recently, other techniques such as MAUA and MCOA, which can take more explicit account of the diverse nature of problems have been suggested (Ref. 1). Descriptions of these techniques can be found in standard texts (e.g. Ref. 1). While their application to potential exposures is under development (Ref. 2).

The application of a decision-aiding technique often brings new insights into the problem and its essential characteristics. Iteration of the whole decision process may then be desirable to refine work done at previous stages. The process of iteration recognises that it is naive to expect that all possible options will be identified and characterised in terms of all attributes at the outset. Even if this were possible, the data needed and the analysis undertaken would make it an enormous task. In general, decisions are made incrementally. Iteration should continue until the decision-maker is happy that he understands the problem and has characterised it well enough to make a decision.

The application of the analytical techniques generally requires a number of value judgements to be made. The results depend on both these judgements and the quality of the data which go into the analysis. For these reasons, a sensitivity study should be performed to determine how robust the analytical solution is to changes in the values assigned to attributes, uncertainty associated with their value, and changes in their relative importance. This often reveals that only a few of the attributes have a significant effect on the decision and that it is the relative importance attached to these that determines which option is preferred.

The Decision

Once the analytical solution is known, the final decision can then be made. This process cannot be completely separated from the previous stages since the way in which options are characterised in terms of the identified attributes, and the analytical solution, depends on the details of the particular analytical technique employed. The criteria defining the 'best' option are implicit in the mechanisms of the technique and the underlying philosophy

on which it is based. For example, in the case of CBA the 'best' alternative is that which maximises the net present monetary value since this is regarded as the measure of an options worth. If all relevant attributes were included in the formal analysis and the chosen technique models the decision-makers preferences fully, then the final decision will correspond to the analytical solution. However, this is unlikely, and at this stage those attributes not included in the formal analysis must be taken into account and the decision modified accordingly.

CONCLUSION

Optimisation in radiological protection is a complex process involving trading-off conflicting objectives. This paper has outlined a general decision-process and a number of decision-aiding techniques which can help the practical implementation of ALARA. The key to the whole process is to start with a simple model and iteratively refine it, simplifying where possible, and only if necessary developing a more detailed characterisation of the problem. Neither the decision-process nor the analytical techniques are algorithms or machines for making decisions. No process or technique can capture all the facets of a decision and the ultimate responsibility for making the decision is always with the decision-maker. The decision-process does, however, help the decision-maker understand his problem more fully, discover which facets of the problem determine the preferred option, and helps communicate to others why, and under what circumstances, a particular course of action is preferred.

REFERENCES

1. ICRP (1989). *Optimisation and Decision-making in Radiological Protection*. ICRP Publication 55. Pergamon Press.
2. F Phillips, H L Wilkinson & R W Allott (1991). *Decision-making in Radiological Protection*. SRD, AEA Technology, TSSD/A/5.
3. D M Beude (1986). Structuring value attributes. *Interfaces*, **16**, 55-62.
4. F Phillips, R W Allott and H L Wilkinson (1991). *The Application of Trees and Hierarchies to Problems in Radiation Protection*. SRD, AEA Technology, SRD/ALARA/WP2.
5. S R Watson & D M Beude (1987). *Decision Synthesis*. Cambridge University Press, Cambridge.
6. R L Keeney & H Raiffa (1976). *Decisions with Multiple Objectives: Preferences and Value Trade-Offs*. Wiley & Sons, New York.
7. R W Allott, H L Wilkinson & F Phillips (1991). *The Quantification of Weighting Factors for Use in Analytical Decision Aiding Techniques*. SRD, AEA Technology, SRD/ALARA/WP3.

ACKNOWLEDGEMENT

The work reported on in this paper was funded by the Commission of European Communities (CEC Proposal Number 890079) and by the Health and Safety Executive/United Kingdom Atomic Energy Authority Nuclear Safety Research Programme (Project Number XTRC 2).

DECISION-MAKING UNDER RISK IN THE OPTIMIZATION OF THE
RADIOLOGICAL PROTECTION APPLIED TO DESIGN

Daniel Germán Hernández

Comisión Nacional de Energía Atómica
Gerencia de Seguridad Radiológica y Nuclear
República Argentina

ABSTRACT

When applying optimization of the radiological protection to design, the corresponding data and parameters may present uncertainties. This paper presents a methodology which allows optimization to be kept under the field of decision-making under risk. This methodology involves the use of the Principle of Maximum Entropy, in order to generate a probability distribution from the available information, while the analytical solution may be assessed by applying the Monte Carlo Method.

INTRODUCTION

When applying optimization of protection procedure to design, lack of precise data on the performance of the protection options, uncertainties due to modeling, or the intrinsic uncertainties of random variables, often appears. If the probability distributions of these variables are unknown, it configures a case of decision-making under uncertainty.

The common way of dealing with this situation consists in assigning most likely values to the mentioned data and, consequently, considering it as a deterministic problem. In order to validate this solution, a sensitivity analysis is carried out.

As an alternative to the above mentioned procedure, another methodology is proposed, which allows to consider the situation as a decision-making under risk one. On doing this, information concerning the data may be recalled from experts, and by applying the Principle of Maximum Entropy to this information, its expert-related distribution is determined. Then, the analytical solution may be assessed by applying the Monte Carlo Method.

Optimization of radiation protection taken as a decision-making under risk problem consists in choosing some option a_i from the set of options A , without knowing in advance the exact state, s_j , that nature will adopt from the set of possible states, S . The probabilities of the states of nature may be denoted P_j ; therefore, the optimum action a_i^* consists in selecting the protection level i associated with action a_i , in such a way that:

$$E(U_i) = \sum_{j=1}^n U_{ij} P_j = \max \quad (1)$$

under the constraints:

$$y_r = f_r(X_1, X_2, \dots, X_k) \leq b_r \quad r = 1, 2, \dots, q \quad (2)$$

$$P [y_r = f_r(X_1, X_2, \dots, X_k) \leq c_r] \geq D_r \quad r = q+1, \dots, R \quad (3)$$

where $Y=f(x)$ denotes functional dependence, while U_{ij} represents the utility of option i , if state j occurs [1,2], and it depends upon design variables (X) through $U=f(X)$. Among these design

variables, collective dose S and costs C should be included, as well as individual dose (H) limitations should be established.

When probabilistic constraints occur, as in expressions (3), only a probability value of attaining a goal, (Dr), may be adopted. If such a goal consists in complying with the individual dose limitation, these limits should be expressed in a probabilistic form [1].

PRINCIPLE OF MAXIMUM ENTROPY OF THE INFORMATION

The probability distribution of any variable may be estimated from information given by experts [3], by applying the Principle of Maximum Entropy (PME). Given the states of nature, s, belonging to an interval R, and being f(s) a probability density function associated to R, a measure of the uncertainty is provided by the entropy of the information, H(f). The PME indicates that, in any case of decision-making under risk, the probability density function which maximizes entropy [4], should be applied.

$$\max \left\{ H(f) \right\} = \max \left\{ - \int_R f(s) \ln \left[f(s) \right] ds \right\} \quad (4)$$

subject to

$$\int_R f(s) ds = 1; \quad f(s) \geq 0 \quad (5)$$

and any constraint given by the available information, such as:

$$\int_R s f(s) ds = med; \quad \int_R (s-med)^2 f(s) ds = \sigma^2 \quad (6)$$

where, med and σ^2 represent values assessed by experts. As a final remark, the PME defines an unique probability distribution, which is the most dispersed one, compatible with the available information. The above mentioned concept justifies the conservatism of the results obtained from its application.

MONTE CARLO METHOD

This is a numerical technique, which allows the assessment of the probability distribution for a given non-linear function, by simulating random variables. For each one of them, a set of values is generated, with the same distribution corresponding to such a variable. These values are replaced in the mathematical model that characterizes the system, defining its response. The distribution of the dependant variable [5], which conceptually represents a hypothetical sampling of the system performance, may be obtained.

NUMERICAL EXAMPLE

As a demonstration, a simplified version of the optimization technique applied to the shielding thickness (t) of a container used for the transfer of burnt fuel elements at Embalse nuclear power plant is presented. This container is a cylindrical vessel, lead shielded and steel jacketed. Both, lead and steel thicknesses must be the same for the lateral surface, the basement and the top. The corresponding values for the calculation parameters are:

- Cost of unit of collective dose = 10 000 US\$/man Sv
- Cost of unit mass of lead = 10 US\$/kg
- Annual individual dose limit = 20 mSv/a

The container will be used throughout 2570 operations during 28 years. On performing the operations, workers identified as A, B, C, D and E will be exposed to radiation, as described below: Workers A and B will carry out tasks 25A and 25B, in an alternate chronogram. Workers C, D and E will deal with tasks 27, 28 y 30 in the same way. As a consequence of this working scheme, workers A and B will receive equal doses, as workers C, D and E will do [6].

Each task is characterized by the time required for its fulfillment (T), and by the distance between the workers and the container (WCD). Both values were obtained from the designers. The values were asked as a mean (MED), as a minimum (MIN) and as a maximum value (MAX). These values are presented at Table 1.

TASK	T (min.)					WCD (m)				
	MIN.	MED.	MAX.	c	μ	MIN.	MED.	MAX.	c	μ
25A	6.0	10.0	30.0	1.079	-0.246	0.2	1.0	5.0	1.577	-1.230
25B	6.0	10.0	30.0	1.079	-0.246	2.5	3.0	3.5	1.0	1.0
27	2.0	3.0	6.0	5.569	-0.898	0.2	1.0	1.5	0.278	1.001
28	2.0	5.0	7.0	0.062	0.246	0.5	1.0	1.3	0.196	1.950
30	0.7	1.0	3.0	33.97	-3.321	0.2	0.5	0.6	0.042	8.984

Table 1. Estimated time and distance for each task, and determined by the Principle of Maximum Entropy.

Equivalent doses (DC) for different distances and shielding thicknesses were calculated by using MERCURE-4 software [7,8]. Based upon experts opinion, it was estimated that the actual doses should be normally distributed with a mean value of 0.8 DC and a variance of 0.2 DC .

The mean values in Table 1 and the estimated doses (DC) were used in order to obtain the solution by applying the cost-benefit technique. The corresponding results are presented in Table 2.

t (cm Pb)	C (US\$)	S (Sv)	U=C+aS (US\$)	H(AB) (mSv/year)	H(CDE) (mSv/year)
7	38230	3.9307	77537	37.24	21.54
8	44590	2.0706	65296	19.57	11.33
9	51190	1.1503	62693*	10.81	6.33
10	58040	0.6193	64233	5.86	3.38
11	65130	0.3406	68536	3.23	1.85

Table 2. Results obtained by applying cost-benefit technique.

In order to obtain the solution by the proposed methodology, the principle of Maximum Entropy was applied to the available data. The corresponding distribution for each variable was assessed by using expressions (4) and (5), and constraint (6) as:

$$\int_{\text{MIN.}}^{\text{MAX.}} s f(s) ds = \text{MED} \quad (7)$$

Proper solutions were determined [4] by applying calculus of variations, resulting in $f(s)=ce^{\mu s}$, while constants c and μ were calculated by using constraints (5) and (7), and are presented in Table 1. The analytical solution was obtained by applying the Monte Carlo technique, which allowed the determination of the distribution of individual and collective doses (Table 3).

t (cm Pb)	C (US\$)	E(U) (US\$)	E[H(AB)] (mSv/y)	E[H(CDE)] (mSv/y)	P(1)	P(2)
7	38230	81525	46.27	30.49	0.2552	0.1439
8	44590	67456	24.42	16.11	0.5082	0.7892
9	51190	63929	13.58	9.02	0.7918	0.9943
10	58040	64712	7.11	4.75	0.9695	1.0
11	65130	68853	3.99	2.62	0.9968	1.0

Table 3. Results obtained by applying decision-making under risk. P(1) denotes $P[H(AB) \leq 20 \text{mSv/y}]$; while $P(2) = P[H(CDE) \leq 20 \text{mSv/y}]$.

According to the cost-benefit technique, the optimized thickness should be 9 cm lead, with a maximum individual dose of 11 mSv/a. The corresponding results for the proposed methodology should be an equal thickness, but a probability P(1) of only 79 % for individual limitation compliance should be accepted.

Cost-benefit techniques require a sensitivity analysis in order to evaluate the stability of its solutions. This analysis presents some problems, such as the lack of a proper methodology of input data selection or that, under certain circumstances, different results are obtained when changing the input data.

On the contrary, the proposed methodology emphasizes the probabilistic features found in most cases in optimization of protection, dealing with the available information accordingly with decision analysis axioms.

CONCLUSIONS

The proposed methodology has demonstrated to be a useful tool for decision-making applied to the optimization of radiation protection under uncertainties. These techniques are adequate in dealing with any kind of random variable, delivering non-contradictory results, with a high degree of coherency with the analyzed situation.

REFERENCES

- [1] International Commission on Radiological Protection; "Optimization and Decision-Making in Radiological Protection", ICRP Publication 55, Pergamon Press, Oxford (1988).
- [2] Beninson D.J.; "Optimization of Radiation Protection as a Special Case of Decision Theory", International Symposium on the Optimization of Radiation Protection, Vienna (1986).
- [3] Winkler R.L.; "The Quantification of Judgment", J. Am. Statist. Assoc. 62, 1105-1120 (1967).
- [4] Cozzolino J.M. and Zahner M.J.; "The Maximum-Entropy Distribution of the Future Market Price of a Stock", Opns. Res. 23, 1200-1211 (1973).
- [5] Siddall J.N.; "Analytical Decision-Making in Engineering Design", Prentice-Hall, New Jersey (1972)
- [6] Hernández D.G., Majchrzak J., Segado R.; "Espesor Optimo de Blindaje-Contenedor de Pileta", Private communication (1990).
- [7] Dupont C., Nimal J.; "Mercure-4"; Rapp. SERMA/T/N° 436 (1980).
- [8] Fruttero N. and Grassi E.; "Estimación de Dosis en Proximidades del Contenedor de Pileta", Private communication (1990).

PRATIQUE DE L'OPTIMISATION DE LA RADIOPROTECTION
SUR LE CENTRE DE RETRAITEMENT DES COMBUSTIBLES IRRADIES
DE LA HAGUE DEPUIS 1976

J. BETIS, Chef du Service Prévention et Radioprotection de
l'Etablissement COGEMA LA HAGUE

OPTIMIZATION OF RADIATION PROTECTION
AT FUEL REPROCESSING PLANT
COGEMA LA HAGUE SINCE 1976

This paper presents the organisation of radiation protection service. The means and methods in connection with the technical measures applied into the facilities have permitted, since 1976, to divide the average annual dose per worker by ten and the activity of liquid radioactive waste by three. In the same time the amount of reprocessed spent fuel was multiplied by six. These figures result from the application of a global optimization approach.

INTRODUCTION

Une usine de retraitement est une usine chimique complexe comprenant de nombreux ateliers à risques potentiels très divers en relation avec l'activité, la nature et la forme physico-chimique des substances radioactives manipulées dans ces ateliers.

Une autre caractéristique est, depuis sa mise en service en 1966, l'évolution qualitative (nature) et quantitative (taux de combustion, tonnage annuel) des combustibles retraités. L'augmentation des risques, associée à cette évolution, a nécessité une adaptation des installations et une mise en oeuvre de moyens importants pour aboutir à une amélioration constante de la radioprotection des personnes.

Le but de cet exposé est de montrer comment COGEMA conçoit et exerce la radioprotection à La Hague, pour limiter l'exposition du personnel, conformément au principe ALARA.

ORGANISATION DE LA RADIOPROTECTION

Pour assumer sa responsabilité en matière de radioprotection, le Directeur de l'Etablissement est assisté d'un service de protection contre les rayonnements (aigle SPR) placé sous sa responsabilité, qui représente 10 % des effectifs (304 personnes), et dont les principales missions sont :

- assistance-conseil en matière de prévention auprès du Directeur et des chefs d'installations, responsables entièrement des installations dont ils ont la charge, y compris de la sécurité radiologique et non radiologique.

- contrôle et surveillance des nuisances radiologiques au niveau des installations (locaux et personnel) et de l'environnement dans toutes les configurations de cea installations (exploitation, maintenance, interventions d'urgence).

PREVENTION DES RISQUES RADIOLOGIQUES

Cette mission du SPR s'exerce à tous les stades de la vie de l'usine :

avant la mise en service par:

- l'aide au concepteur : analyse du risque radiologique, des méthodes d'intervention en maintenance, dépannage, des flux d'effluents et déchets, de l'organisation des postes de travail

- les essais et vérification des mesures de radioprotection des installations avant démarrage en actif

- la traduction opérationnelle de la réglementation en matière de radioprotection

- la formation du personnel au travail en milieu ionisant

au cours du fonctionnement

- le rôle préventif consiste à déclencher et à signaler le plus tôt possible toute dérive ou anomalie de "l'ambiance radiologique" des installations mise en évidence lors des nombreux contrôles continus ou périodiques portant sur les travailleurs, les locaux, les matériels, les déchets, les effluents, etc...

- tout travail présentant un risque radiologique doit être préparé et autorisé par un document appelé dossier d'intervention en milieu radioactif (DIMR).

Ce dossier comporte la description de l'intervention par l'exploitant, l'analyse du risque radiologique, une estimation du bilan dosimétrique et les conditions optimisées dans lesquelles doivent s'effectuer cette intervention, définies par le SPR.

Ensuite pendant l'intervention, s'exerce un suivi permettant de s'assurer que les conditions radiologiques du chantier restent dans les limites prévues par le DIMR et que le bilan dosimétrique est conforme aux prévisions (utilisation d'une dosimétrie opérationnelle automatisée par stylo-dosimètres).

SURVEILLANCE DES RISQUES RADIOLOGIQUES

La politique menée en matière de prévention ne peut être jugée et améliorée que par un suivi adapté des nuisances radiologiques :

- surveillance collective de l'état radiologique des locaux
- surveillance, contrôle et bilans de tous les rejets d'effluents

complétée par une mesure de l'impact de ces nuisances sur le personnel et la population :

- suivi de la dosimétrie du personnel

- surveillance de l'environnement.

Pour assurer tous ces suivis et surveillance, deux types de moyens sont toujours utilisés :

- des moyens de surveillance en temps réel qui assurent une fonction d'alarme permettant de détecter des évolutions rapides et importantes des paramètres surveillés et d'enclencher rapidement les mesures correctives qui s'imposent.

- des moyens de contrôles avec mesures en temps différé qui assurent une fonction de suivi fin, de détection d'évolution lente et de bilans précis des paramètres surveillés.

RESULTATS ET CONCLUSIONS

L'application des principes et la mise en oeuvre des moyens qui viennent d'être exposés a permis à COGEMA de maîtriser et de réduire au fil des années :

- l'exposition du personnel (cf figures 1 et 2)
- les rejets d'effluents (cf figure 3)

tout en augmentant sa production.

Figure 1

RESULTATS DOSIMETRIE Dose moyenne annuelle par agent (Personnel catégories A et B)

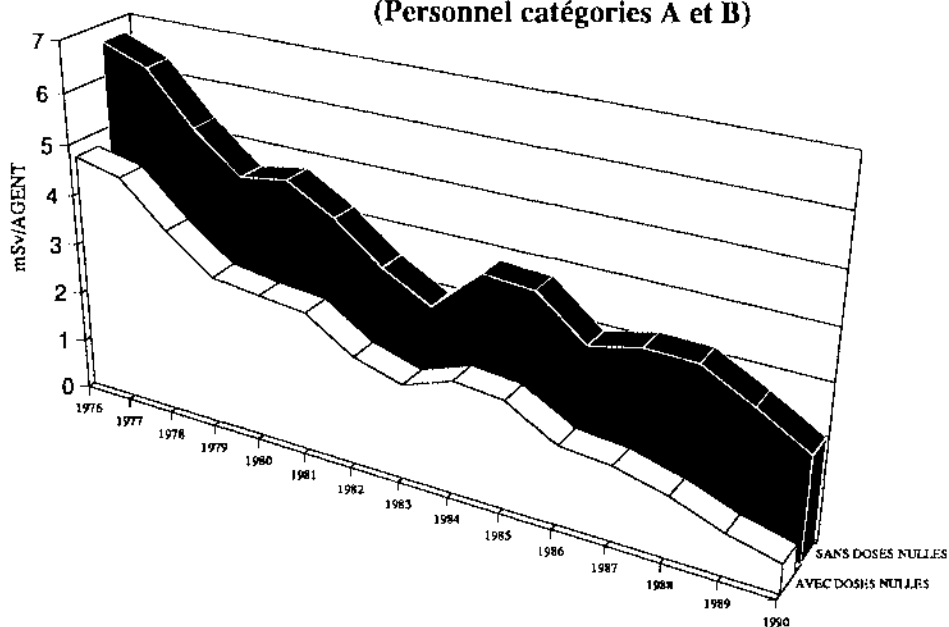

Figure 2

RESULTATS DOSIMETRIE
Doses annuelles ramenées à la production

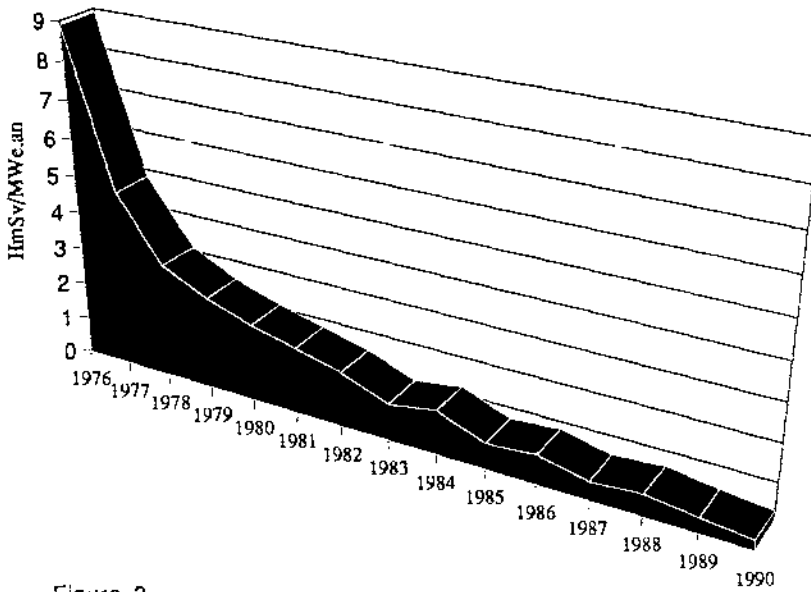
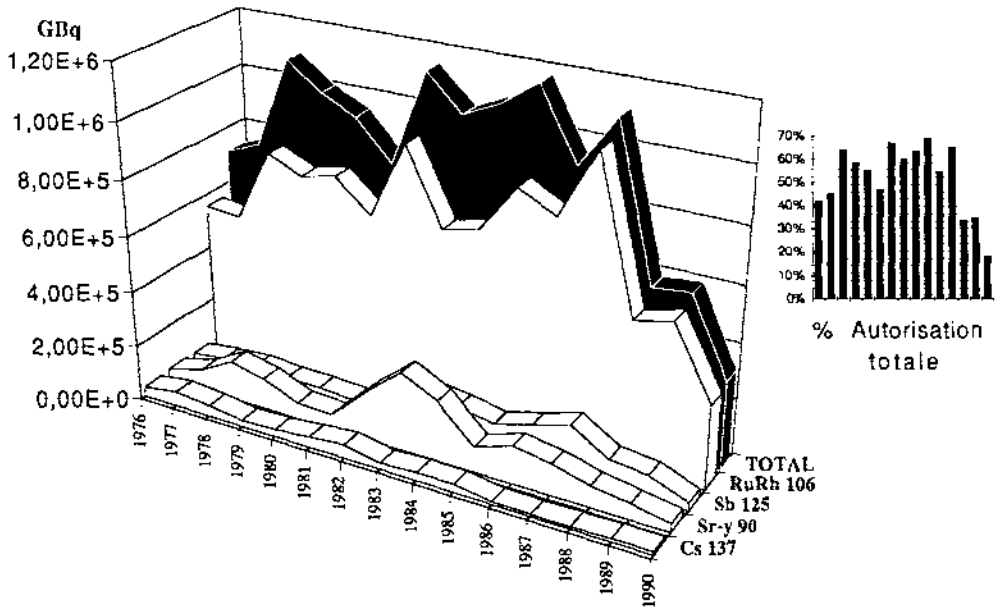

Figure 3

REJETS LIQUIDES : BETA GAMMA
AUTORISATION ANNUELLE DE REJET : 1700 TBq soit \approx 45000 Ci



**OPTIMISATION DE LA RADIOPROTECTION DANS
L'OPERATION DE CHANGEMENT DE BROCHES
DE TUBES GUIDE DE GRAPPES D'UNE
CENTRALE A EAU PRESSURISEE**

--:--:--:--:--:--:--

**Alain BLAIN (Département Radioprotection)
Bernard BREGEON (Département Radioprotection)
Patrice SAUMON (Département Etudes et Développements)**

FRAMATOME, 10 Rue Juliette Récamier, 69006 - LYON

**RADIOPROTECTION OPTIMISATION DURING RCCA GUIDE TUBES PINS
REPLACEMENT IN A PRESSURIZED WATER REACTOR**

Initially due to incidental occurrences (Japan in 1978, France in 1982), pins replacement became a systematic and repetitive operation. Between 1983 and 1991, more than 4000 pins has been replaced in France and abroad. The average dose per replaced pin has been decreased with a ratio of approximately 8 (from 1,25 mSv/pin in 1982 to 0,14 mSv/pin in 1991). It is due, in a first step, to equipment modification and improvement and, in a second step, to highly skilled personnel, experience feed back and environmental conditions.

I - INTRODUCTION

Les problèmes rencontrés fin 1978 au Japon (fissures et ruptures) sur les broches de MIHAMA 3 ont incité FRAMATOME à prendre des mesures préventives de plusieurs types :

- Développement d'un dispositif de contrôle non destructif par ultra-sons.
- Etude d'une machine de changement de broches
- Recherches métallurgiques et mécaniques sur les broches elles-mêmes.

Lorsqu'en 1982 sont survenus des incidents sur Gravelines 1, Fessenheim 1 et Bugey 2, (incidents similaires à ceux rencontrés au Japon) il est apparu qu'ils avaient un caractère générique et qu'ils nécessitaient une action globale.

Dans un premier temps, il y a eu r eplacement pur et simple des tubes guide par des tubes guide neufs et parallèlement à cette action a été menée l'étude d'un dispositif de remplacement des broches.

L'objet du présent exposé est de montrer comment a évolué l'intervention depuis 1982 et quelles ont été les conséquences dosimétriques de cette évolution.

Nous précisons que ceci ne concerne que le changement de broches proprement dit et exclut les opérations amont et aval, à savoir les démontage, transfert et remontage des tubes guide sur site ou en atelier.

II - EVOLUTION DES MOYENS MIS EN OEUVRE

2.1. Remplacement d'une broche : procédure générale

Le remplacement d'une broche est réalisé en respectant la chronologie suivante :

Phase 1 - Désolidarisation de la goupille et de la rondelle d'arrêt par destruction de la soudure.

Phase 2 - Désolidarisation de l'écrou et de la broche.

Phase 3 - Retrait de la broche

Phase 4 - Retrait de l'écrou

Phase 5 - Nettoyage des lamages

Phase 6 - Mise en place écrou

Phase 7 - Mise en place et vissage de la broche

Phase 8 - Soudage goupille/rondelle d'arrêt.

NOTA : Les phases 1 et 2 sont maintenant réalisées en même temps (étincelage de la soudure et du filetage de la broche simultanément).

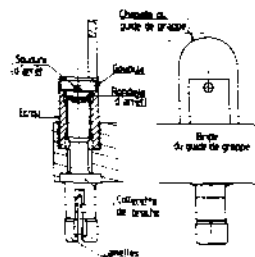

Présentation d'une broche montée sur un guide de groupe

2.2. Nuisances radiologiques

Les nuisances radiologiques sont dues :

- à l'activité massique des éléments constituant la partie basse du tube guide. Elle varie de 40 à 80 MBq/g (1 à 2 mCi/g) et induit un débit de dose de 5 cm de 2 à 4 Gy/h.
- à l'activité surfacique de l'ensemble du tube guide qui est de l'ordre de 1 MBq.cm⁻².

2.3. Evolution des moyens mis en oeuvre

FESSENHEIM (02/83)

Le délai très court pour la conception et la réalisation des stands chauds a fait que le stand est arrivé à Fessenheim alors qu'il n'en était qu'au stade d'un prototype en cours de mise au point. Après des essais infructueux de remplacement de broches ; il a été décidé de mettre en oeuvre le stand de secours EDF appelé communément "TOTEM".

Le TOTEM est constitué d'une cellule rotative en plomb sur laquelle vient s'appuyer la hotte de manutention des tubes guide.

Toutes les opérations de démontage et remontage des broches s'effectuent en manuel au travers de portes situées en regard des broches.

Tous ces travaux s'effectuent à l'intérieur d'une enceinte de confinement où les opérateurs travaillent en tenue confinée type MURUROA. L'opération de soudage de la barette d'arrêt est néanmoins réalisée sur le stand chaud.

STAND CHAUD

Le stand chaud est un confinement dans lequel sont installés six postes de travail. Le tube guide y est introduit et tourne pour être présenté successivement sur chacun des postes. Les opérateurs situés à l'extérieur du stand, sont protégés de l'irradiation et de la contamination dues au tube guide et peuvent visualiser chacune des opérations.

BUGEY (04/83)

Afin de remplacer les broches de Bugey, un stand chaud est installé dans un local sur le site. Le stand de secours (TOTEM) de Fessenheim est installé dans le Bâtiment combustible de BG 2. 21 tubes guide sont traités sur le TOTEM et stand chaud pour la soudure.

En parallèle à ces opérations, le stand chaud est rendu opérationnel et l'ensemble du reste des tubes guide sont traités sur le stand et l'utilisation du TOTEM est abandonné.

TRICASTIN (04 à 11/83)

Compte tenu des conditions difficiles d'environnement pour l'exploitation du stand à Bugey, EDF installe dans un local "chaud" de la Centrale de Tricastin, un atelier broche équipé de deux stands chauds simplifiés pour le remplacement total des broches et d'un stand de secours équipé d'un dispositif de meulage et de clef à sangle, de principe identique au TOTEM.

PIERRELATTE (12/83 à 12/87)

Afin de satisfaire les besoins industriels de remplacement des broches du parc électronucléaire français que ne peut satisfaire l'atelier de Tricastin, EDF confie à FRAMATOME l'ingénierie de définition et de conception de l'usine à broches de Pierrelatte sur le site de la COGEMA.

Cet atelier bénéficie du retour d'expérience de Bugey et Tricastin, tant sur le plan technique que sur le plan radioprotection.

Il est équipé de 4 stands chauds disposés en deux lignes de production pour le remplacement des broches, d'un stand de mesure d'entraxe des broches et d'un stand de remplacement des coupelles d'arrêt de la liaison des parties inférieure et supérieure des tubes guide.

BASE CHAUDE OPERATIONNELLE DE TRICASTIN

Afin d'effectuer la maintenance des outillages servant en centrale nucléaire, EDF met en exploitation en 1988 la BCOT. L'atelier de remplacement des broches de Pierrelatte est transféré à la BCOT.

STAND CHAUD EXPORT

Afin de satisfaire aux besoins spécifiques d'exploitant étrangers, FRAMATOME a mis au point une unité mobile (stand chaud et son environnement) permettant de remplacer les broches in situ sur n'importe quel site PWR.

III - BILAN

Plus de 4000 broches ont été remplacées à ce jour dont 10 % environ sur des sites étrangers (USA, Afrique du Sud, Suède) à l'aide du stand chaud mobile.

Les résultats dosimétriques sont résumés dans le tableau suivant :

SITES	FR	BG	TH	Pierre -latte	BCOT	EXPORT
Equivalent dose moyen par broche (mSv)	1,27	0,60	0,69	0,20	0,14	0,20

L'équivalent de dose moyen intégré pour la totalité des opérations de changement de broches est de 0,33 mSv par broche.

L'évolution constatée s'explique par :

- le retour d'expérience
- le changement de procédé après Fessenheim
- l'amélioration des stands après Tricastin
- les conditions d'environnement optimisées à la BCOT.
- l'expérience du personnel intervenant.

En ce qui concerne les opérations à l'export, l'unité mobile a bénéficié des dernières améliorations dues au retour d'expérience mais est tributaire des conditions radiologiques particulières de chaque site.

IV - CONCLUSION

Le produit "remplacement de broche" a démontré ses performances techniques, et paraît, à ce jour, difficilement améliorable sur le plan de la radioprotection dans le cadre du concept coût-efficacité.

LA POLITIQUE D'OPTIMISATION DE LA RADIOPROTECTION
A ELECTRICITE DE FRANCE

Lucien BERTRON - Laurent STRICKER
EDF - Direction Production Transport - Paris

ELECTRICITE DE FRANCE POLICY FOR OPTIMISATION
OF OCCUPATIONAL RADIATION PROTECTION

ABSTRACT

The ALARA concept is now applied widely throughout the nuclear industry and has helped significantly reduce doses. The new dose limits imposed by the CIPR - considerably below those used at present - should encourage nuclear plant managers to organize actions involving all their staff to ensure this concept is applied even more stringently. The increased expenditure required to apply these new standards will also incite managers to carry out research programs to assess the true effects of small doses.

INTRODUCTION

La radioprotection est, au même titre que la sûreté, une des composantes de l'acceptation des centrales nucléaires.

Le concept ALARA, qui figure dans les recommandations de la CIPR, s'est largement développé dans l'ensemble du monde nucléaire. Aller volontairement au-delà du simple respect des limites de la réglementation constitue un changement de comportement qui s'apparente, pour le monde industriel, à une petite révolution. Les raisons explicites qui ont poussé les responsables du nucléaire à agir de la sorte sont sans doute assez confuses et peuvent même cacher une crainte inavouée du nucléaire. Quoi qu'il en soit, les résultats sont positifs et nous devons tous nous en féliciter.

Reconnaissons cependant que l'application du concept ALARA s'est faite de façon assez inorganisée faute de référence. Il suffit pour s'en persuader de constater les écarts considérables qui existent dans les investissements que nous avons consentis pour économiser une fraction d'homme.sievert.

La CIPR, dans sa publication n° 60, a recommandé de nouvelles valeurs de limite de doses beaucoup plus sévères. Ceci pourrait laisser penser que notre personnel était jusqu'à maintenant mal protégé, ce que contredisent la plupart des enquêtes épidémiologiques faites dans différents pays sur les travailleurs des centrales nucléaires. Quoi que nous puissions penser de la légitimité scientifique des nouvelles limites, il est évident qu'elles seront reprises,

pour ce qui nous concerne, dans la réglementation européenne et prendront force de loi dans les réglementations nationales vers 1995/96.

Face à cette nouvelle réglementation, l'exploitant peut adopter deux attitudes :

- se contenter de veiller au respect des limites de doses,
- donner le maximum d'importance à l'application du concept ALARA.

La seule attitude possible et responsable est bien évidemment la deuxième pour, au moins, trois raisons :

- La première est que l'application stricte de la réglementation pourrait conduire à une augmentation significative des doses collectives par partage des doses, ce qui n'est pas le but recherché et ce qui, pour les médecins, aboutirait à tort ou à raison à augmenter le nombre de cancers attendus.
- La seconde est que par un souci extrême de prudence on considère qu'il n'y a pas de seuil pour les risques de cancers et d'anomalies génétiques ; il est donc raisonnable de vouloir diminuer les doses reçues par le personnel.
- La troisième est que les hommes de l'énergie nucléaire doivent être sans cesse à la recherche de la perfection dans tous les domaines : sûreté, disponibilité, maîtrise des coûts, communication, etc... Cela implique une culture, une façon de penser et d'agir qu'il sera nécessaire, si ce n'est déjà fait, d'inculquer à chaque travailleur.

L'application du principe ALARA relève fondamentalement de cette culture.

QUELLE DEMARCHE POUR DE VERITABLES PROGRES

La démarche ALARA est la seule démarche de progrès possible. Mais elle doit être décidée (les dirigeants doivent afficher clairement la volonté de s'engager dans cette démarche) et organisée selon un processus rationnel qui implique l'ensemble des corps de métiers. Quelques axes de cette démarche peuvent être identifiés :

- L'exploitation : il convient d'identifier et de mettre en oeuvre les méthodes d'exploitation visant à réduire la contamination des circuits. Ceci est particulièrement vrai dans la phase qui précède l'ouverture des circuits lors des arrêts de tranche.

- La décontamination des matériels : elle doit être effectuée dans un souci d'optimisation. Il convient de trouver le juste milieu entre la contamination génératrice de doses pour les travailleurs et la décontamination trop poussée qui expose inutilement les agents chargés de ce travail et génère des déchets.
- L'identification des postes de travail qui induisent les doses les plus importantes. Ceci doit permettre d'optimiser judicieusement les investissements à faire en matière de protection, d'outillage, de robot, pour réduire les doses individuelles ou collectives. Cette démarche passe nécessairement par un bilan coût/dose évitée qui suppose, pour la cohérence des actions engagées, une référence, au moins implicite, au coût de l'homme.sievert. C'est ce que nous essayons de faire à Electricité de France.
- L'organisation des chantiers, concrétisée par des "plans qualité, sûreté" établis à partir de l'analyse des risques, précisant notamment les protections, les moyens de confinement, le matériel de contrôle à utiliser, etc... et donnant une indication de la dose jugée raisonnable compte tenu des travaux à réaliser, qui servira de référence.
- Le retour d'expérience : l'organisation méthodique du travail doit s'appuyer sur le retour d'expérience. De ce point de vue, la nature standardisée du parc nucléaire français est un facteur très favorable. Un système de gestion des doses, couplé à une base de données, a été mis en place. Il permet au niveau de chaque site d'établir les prévisions de doses pour une intervention déterminée, d'en effectuer le suivi en cours d'opération et, enfin, de les analyser pour apporter les améliorations qui seront susceptibles de réduire encore les doses pour les prochaines interventions.
- La sensibilisation et la formation du personnel.

Indépendamment de la culture qualité qui doit animer chaque agent travaillant dans une centrale nucléaire, la réduction des doses passe par une prise de conscience des exigences liées à la radioprotection par les personnes chargées d'organiser et d'exécuter le travail. Il ne sert à rien de mettre en oeuvre des techniques d'intervention sophistiquées si le personnel n'a pas lui-même le souci de se soustraire du champ d'exposition chaque fois qu'il en a l'occasion.

Un des facteurs important de la réduction des doses est la réduction du temps d'intervention obtenue par l'entraînement du personnel. A cet effet, Electricité de France a construit en association avec FRAMATOME un centre technique où le personnel peut s'entraîner dans les conditions réelles d'intervention qu'il rencontrera in situ.

CONCLUSION

Tôt ou tard l'énergie nucléaire connaîtra un développement important. C'est en effet la meilleure façon de protéger l'environnement de notre planète tout en assurant aux hommes qui la peuplent l'énergie dont ils ont besoin et dont certains souffrent cruellement d'un très grand manque. L'opinion publique et nos dirigeants prendront un jour (et le plus tôt sera le mieux) conscience de cette réalité. Nous devons nous préparer à un revirement d'opinion en investissant dès aujourd'hui dans deux domaines :

- La sûreté : une large réflexion qui porte sur le concept des réacteurs du futur est déjà engagée au niveau international et devrait conduire à des réacteurs encore plus sûrs que ceux d'aujourd'hui, dans un large consensus international. Il serait bon d'intégrer dans cette réflexion l'aspect radioprotection qui doit être pris en compte dès le stade de la conception.
- La radioprotection.

Nous constatons depuis déjà de nombreuses années un désintérêt de la communauté nucléaire pour ce qui concerne la recherche fondamentale touchant la radioprotection. Des efforts importants devraient être consentis dans différents domaines, notamment sur les effets carcinogènes des faibles doses, sur la modélisation des risques, sur la dosimétrie biologique et les soins aux irradiés.

Nous acceptons aujourd'hui par facilité la loi linéaire dose/effet, associée à la non-existence de seuil pour les risques de cancers et d'anomalies génétiques, qui va certes dans le sens de la sécurité mais qui induit des investissements considérables dont on peut se demander s'ils ne seraient pas plus utiles ailleurs.

Les exploitants doivent être moteurs dans cette recherche en participant dans une large mesure aux orientations et au financement des programmes.

Une collaboration internationale dans ce domaine serait bien entendu extrêmement précieuse.

De même, nous devons poursuivre et intensifier nos efforts en matière d'études épidémiologiques pour confirmer que les personnels exposés professionnellement aux rayonnements ionisants ne sont pas soumis à des risques supérieurs. Ces études épidémiologiques n'auront de sens que si elles sont réalisées sur une grande échelle, c'est-à-dire au niveau international, ce qui suppose une harmonisation des méthodes de mesures et de comptabilisation des doses. Dans le domaine de la radioprotection, comme pour beaucoup d'autres domaines, les progrès que nous ferons dépendront largement de notre capacité à travailler ensemble. L'énergie nucléaire a besoin, pour se développer, d'un large consensus international.

A Practical Method for the Application of the As Low As Reasonably Practicable (ALARP) Principle in Facility Design

R G Jackson
SRD
AEA Technology
Wigshaw Lane, Culcheth,
Warrington, Cheshire, WA3 4NE
ENGLAND

ABSTRACT

A structured methodology has been prepared for the application of the ALARP principle throughout the design of a large nuclear facility based on design targets and design limits laid down in the company's radiological protection policy. ALARP reviews at each stage of the design process ensure that the final design will comply with the statutory requirement to restrict all exposures to ionising radiations as far as is reasonably practicable.

INTRODUCTION

In the UK the main radiological protection legislation requires that all exposures shall be restricted as far as is reasonably practicable. This is generally known as 'As Low As Reasonably Practicable (ALARP)' rather than the ICRP terminology 'As Low As Reasonably Achievable (ALARA)'. The term 'reasonably practicable' has been defined by English case law to require the reduction of risks so that the sacrifice required to reduce them further is grossly disproportionate in terms of time, effort or cost compared to the reduction in risk which would be achieved.

ALARP is generally considered to embrace ALARA and to be more restrictive rather than less. In order to demonstrate quantitatively that exposures will be ALARP it is not necessarily sufficient to balance costs and detriments but to err in favour of reducing detriments further.

This paper describes a scheme for the demonstrable application of the ALARP principle throughout the design process. The scheme uses Design Targets and Design Limits as a starting point in the application of ALARP. At each stage in the design process the design is reviewed to see whether exposures are likely to be ALARP. Where average doses are above or close to the Design Targets quantitative justification methods are required to be used. A simple method based on Cost Benefit Analysis which emphasises the importance of achieving the Design Targets is described.

INTERPRETATION OF ALARP

The Ionising Radiations Regulations 1985 (IRRs) (ref 1) require all reasonably practicable steps to be taken to restrict exposures to radiation. In UK case law this is taken to mean that there should be a gross disproportion between the amount that an employer would have to spend on reducing exposures and

the corresponding reduction in risk when expressed in monetary terms. The same process should also be applied to the risks from potential exposures from accidents where both the exposures as a consequence of the accident and the frequency with which the accident occurs will be made ALARP.

The Approved Code of Practice to the IRRs (ref 2) gives advice on the application of the ALARP principle.

In choosing between restricting dose to individuals and doses to groups priority should be given to keeping individual doses as far below dose limits as reasonably practicable. Dose sharing between individuals should not be used as the primary method of complying with dose limits.

It is unlikely that all reasonably practicable steps have been taken to restrict exposures of employees who do not normally work with radioactivity if they exceed one tenth of the annual dose limit to workers.

Engineering controls should almost invariably be provided to reduce exposures to persons from external radiation. Priority should be given to the containment of radioactive substances as a means of preventing dispersal or contamination rather than by applying ventilation.

THE ALARP PROCESS

The ALARP process in radiological protection is concerned with making decisions on the risks from routine and accidental exposures to radiation. Above a certain level risks become unacceptable; below a certain level risks may be accepted as being negligible. Between these two levels is the area in which the ALARP principle is important in determining the balance.

The application of the ALARP principle during the design stage of a large facility requires a structured approach. A sound radiological protection policy is required to provide a starting point for the design process. As the design progresses each design decision must then be considered with regard to the whether predicted exposures or risks from accidental exposures will be ALARP. In some cases it will be necessary to utilise quantitative methods to aid in decision making although the final decision must take into account any relevant non-quantifiable factors.

The final outcome must be a detailed demonstration that either doses and risks are negligible or that they have been justified as being ALARP based on an acceptable methodology.

RADIOLOGICAL PROTECTION POLICY

In developing the basis for the facility a policy statement on radiological protection has been prepared. In addition to the requirement to comply with all current legislation the policy provides a starting point for the application of the ALARP in the form of:

a) Design limits on individual dose and segregation distances for transport which the design must meet.

b) Design targets for average doses and risks from accidental exposures of different groups of workers and members of the public to radiation and the frequency of occurrence of accidents resulting in more than a defined radiation dose to the public which should be met unless it is impracticable or excessively expensive to do so.

c) The requirement that design limits and design targets for radiation and non-radiation workers shall not be achieved by artificial dose sharing.

Engineered safeguards in the facility will include shielding, containment (including that provided by the package construction) and ventilation. Radiological protection guidelines have been prepared for designers to assist in the implementation of the radiological protection policy.

IMPLEMENTATION OF THE ALARP PROCESS

The design process can be broken down into a number of individual stages. At each stage safety documentation is required and this will include demonstration that exposures will be ALARP. To determine that this is the case an ALARP review will be carried out to the level of detail appropriate to the particular stage of the design. Emphasis is placed on the use of engineered safeguards.

During the initial feasibility studies assumptions, calculations, experiments, measurements etc. will be made to determine the basic parameters affecting routine exposures and risks from accidental exposures of workers and members of the public as a basis for a conceptual design.

In preparing the conceptual design the specific requirements of radiological protection legislation and the radiological protection guidelines for designers will need to be taken into account.

As required by the IRRs (ref 1) and the ACOP (ref 2) the design should use good engineering practices to reduce radiation exposures. Unnecessary occupancy of any area with significant expected radiation or potential contamination levels should be avoided. Wherever reasonably practicable, radiological and accident protection should be provided by engineered means (such as shielding, remote handling, physical barriers to access, fail-safe systems, containment, ventilation and filtration) rather than by limiting working times in each area or by procedural means. In the more hazardous areas the dose rates will determine the allowable access (i.e. regular, occasional or exceptional) which will identify the reliability/recoverability which must be built in to any handling equipment.

The radiological information available at the conceptual design stage will enable initial estimates of doses and risks which may be incurred to be compared with the design targets and

design limits showing how they will be met or, in the case of the design targets, why they cannot be achieved. Initial estimates should be made of the differential costs of further reductions below the targets or savings from not meeting the targets.

The details of doses and risks to workers and members of the public and the associated differential costs will become more refined through the preliminary design to the detailed design. At each stage an ALARP review will be undertaken by suitably experienced personnel who will determine whether further increases in protection or any relaxations above the targets are justified.

A simple form of cost benefit analysis is recommended where doses/risks exceed some fraction of the design target to be determined by consideration of, inter alia, the uncertainties in the relevant calculations. The method is based on a band scheme where if the cost of any modification per man seivert saved is less than or equal to the value placed on the detriment the modification should be implemented; if the cost of the modification is more than 10 times the value of the detriment then it is probably not justified and in the intermediate band there is no clear decision and further factors must be considered. To emphasise the desirability of achieving the targets the collective dose cost bands for doses above the targets are a factor of 10 higher than for individual doses below the targets.

The review process continues through design changes during procurement and contract arrangements to the final design. The final ALARP review at the design stage must identify any areas of uncertainty which need to be assessed further during construction and commissioning.

CONCLUSION

The procedure developed will provide a structured methodology for the application of the ALARP principle throughout the design of the facility. Documentation prepared as part of the process will demonstrate that the radiological protection provided by the design, by engineered means wherever possible, is capable of meeting the statutory requirement to restrict all exposures to ionising radiation as far as reasonably practicable.

REFERENCES

1. The Ionising Radiations Regulations Regulations 1985, SI 1985/1333, HMSO.
2. Approved Code of Practice to the Ionising Radiations Regulations Part 1 (1985), Part 3 (1987) and Part 4 (1991), HMSO.

BILAN DOSIMETRIQUE DES REVISIONS DECENNALES DES
UNITES 2 - 4 et 5 REALISEES EN 1990-1991
AU CENTRE DE PRODUCTION NUCLEAIRE DU BUGEY

Jean FLUCHERE
EDF - Centre de Production Nucléaire du BUGEY

TOTAL DOSIMETRY FOR THE TEN YEAR OUTAGES OF
UNITS 2 - 4 AND 5 CARRIED OUT IN 1990-1991
AT THE BUGEY NUCLEAR GENERATING CENTRE

ABSTRACT :

The French regulation imposes a very important revision for pressurized water reactors which must be carried out every 10 years. Altogether, all the interventions on the primary and secondary circuits represented 800,000 hours of work for each unit. Total dosimetry varied from 3.45 Sv for Bugey 5 to 6.38 Sv for Bugey 2 - these results were very close to the previsions made according to the activity index of the primary circuit

1. PRESENTATION

La réglementation Française impose pour les réacteurs PWR une importante révision tous les 10 ans. Sur les unités du C.P.N. BUGEY, cette révision a été mise à profit pour réaliser les modifications permettant la mise à niveau avec les unités de 900 MW démarrées 10 ans plus tard. L'ensemble des interventions réalisées sur le primaire et le secondaire a représenté environ 800 000 heures de travail.

2. PREVISIONS DOSIMETRIQUES

Depuis le démarrage du palier 900 MW, EDF a corrélié la dosimétrie collective des révisions avec l'indice d'activité de l'installation. Cet indice est la moyenne arithmétique des mesures de débit de dose en mSv/h effectuées le premier jour de l'arrêt, 12 à 16 heures après la chute des grappes, sur les trois boucles du circuit primaire. En avril 1982, EDF estimait que la dose collective d'une révision décennale serait de 6,95 Sv pour un indice d'activité de 190

3. MESURES PRISES POUR REDUIRE LA DOSIMETRIE

3.1 REDUCTION DE L'ACTIVITE DUE AUX PRODUITS DE CORROSION

Les produits de corrosion activés sont responsables d'environ 90 % des doses reçues par le personnel. On estime qu'à l'équilibre, vers le 10e cycle, les isotopes 58 et 60 du Cobalt représentent respectivement 30 % et 50 % des doses.

Pour réduire l'activité induite par ces produits, il convient de surveiller très étroitement la chimie de l'eau du circuit primaire. EDF a mis en application depuis 1980 une procédure chimique à concentration en lithine décroissante, coordonnée à la concentration en bore, permettant de conserver un pH constant à chaud égal à 6,9. Si une très large unanimité s'est faite, au plan international, parmi les exploitants PWR pour reconnaître l'intérêt d'un pH constant à chaud, il existe encore des divergences sur sa valeur optimale (entre 7,0 et 7,5). EDF réalise actuellement un essai à pH = 7,1 sur quelques unités.

3.2. EPURATION CHIMIQUE LORS DU PASSAGE EN ARRET A FROID

La baisse de la température et du pH entraîne une augmentation de la solubilité des différentes espèces métalliques que l'on rencontre dans un PWR. Ceci permet de transférer l'activité déposée sur les structures du circuit primaire vers l'eau.

Ensuite l'épuration de l'eau primaire permet d'éliminer l'activité remise en solution. Depuis 1984, EDF utilise une procédure chimique très stricte lors du passage à l'état d'arrêt à froid pour intervention et ne commence l'oxygénation qu'à partir de 120° C.

3.3. PROTECTION DES CHANTIERS

Dans les centrales PWR le risque majeur est plus celui de l'irradiation que celui de la contamination volumique. Il convient donc dans la mesure du possible de limiter les durées d'exposition. Par exemple : les rajouts des protections de sols (buvards, vinyls) ont disparu compte tenu de la présence de peintures décontaminables. L'expérience a montré que, dans de nombreux cas, la construction de sas de confinement pouvait être remplacée par des dispositifs préfabriqués de confinement dynamique par aspiration d'air. Les feuilles de plomb, difficiles à mettre en place et en forme, ont été remplacées par des matelas de mousse de plomb souples et disposant de systèmes de fixation intégrés.

Par ailleurs, chaque fois que cela est possible, les interventions sont réalisées avec les circuits pleins d'eau.

Enfin dès la préparation des interventions, on cherche à réduire au maximum les durées d'exposition.

**3.4. ORGANISATION DE LA SECURITE RADIOPROTECTION PENDANT
LES REVISIONS DECENNALES**

Les révisions se succédant sans "temps mort", il a été nécessaire de construire une organisation particulière pour tirer rapidement le maximum de profit du retour d'expérience.

Cette organisation comprend une vingtaine de personnes conduite par un responsable directement rattaché à l'ingénieur chef de la Structure d'arrêt. Ce personnel travaille en 2 x 8 (ou en 3 x 8), conseille les intervenants et assure toutes les cartographies.

4. RESULTATS OBTENUS SUR BUGEY 2 - 4 - 5

UNITE	INDICE 90/91	PREVISION Sv 90/91	RESULTAT Sv	INDICE 82	PREVISION 82
BUGEY2	152	6,76	6,38	190	6,95
BUGEY4	91	4,14	5,72		
BUGEY5	52	3,68	3,45		

COMMENTAIRES

BUGEY2 a un indice élevé suite a des ruptures de gaines consécutives à des problèmes de jets de baffles.

BUGEY4 a connu des chantiers imprévus très lourds en dosimétrie.

5. CONCLUSIONS

Les décennales ont été plus "lourdes" en heures de travail que ce qui était prévu en 1982 notamment en raison de la réalisation des modifications et d'un volume très important de contrôles non destructifs. Mais les dispositions préventives prises montrent que la dosimétrie totale est tout de même inférieure : 6,38 Sv pour BUGEY2 contre 6,95.

Les résultats sont conformes aux prévisions (BUGEY2 et BUGEY5) quand les chantiers réalisés sont ceux qui étaient programmés.

UN CAS D'OPTIMISATION DE LA RADIOPROTECTION
LE PREMIER RGV FRANCAIS: DAMPIERRE 1990

R.Hochart, O.Jurion
Electricité de France

AN EXAMPLE OF OPTIMISATION IN RADIATION PROTECTION
THE FIRST FRENCH STEAM GENERATOR REPLACEMENT : DAMPIERRE
1990

2,13 man.sievert for replacing 3 steam generators with less than 10 RP technicians in the field; this outstanding result stems from a three-faced approach: extensively utilizing the complete set of actions on exposure constituents (sources, shielding, duration, distance), implementing a real radiation protection management thanks to the development of adequate tools and finally, reinforcing the individual radiation protection philosophy in practised in France.

INTRODUCTION

Le résultat dosimétrique remarquable de 2,13 homme.Siévert pour le remplacement de 3 générateurs de vapeur sous contrôle opérationnel de moins de 10 techniciens de radioprotection est le fruit d'une approche associant à la panoplie classique des actions pour réduire les doses, une gestion de la radioprotection collective et une philosophie de la radioprotection individuelle.

VERS UNE VERITABLE GESTION DE LA RADIOPROTECTION

La mise en oeuvre d'une véritable gestion de la radioprotection a été rendue possible par le développement d'outils adéquats, qui font par ailleurs l'objet d'autres présentations. Il s'agit, d'un système de suivi des doses en temps réel (FLEXIDOSE), d'une modélisation des tâches (nombre d'intervenants, durée, débit de dose) et de la base de données associée (DOSIANA) et enfin d'un outil de prévision des débits de doses (PANTHERE). Ces outils ont permis:

- une prévision analytique de la dosimétrie globale de l'opération, la définition d'objectifs et la mesure des écarts en temps réel pour actions correctives,
- des simulations pour évaluation des actions de protection donnant tout son sens au principe ALARA. Cependant ces simulations sont restées limitées à l'optimisation des mouvements d'eau, à la définition des protections biologiques à installer et à la validation du choix de décontamination des tuyauteries primaires.

Les options techniques de base de l'opération n'ont pas été prises en utilisant ces outils mais en évaluant les bilans dosimétriques de façon approchée.

L'ACTION SUR LES ELEMENTS CONSTITUTIFS DES DOSES

La panoplie classique mais complète des moyens d'actions sur les éléments constitutifs des doses (sources, écrans, durée et distance) a été utilisée :

La réduction des sources

L'analyse du niveau de contamination relativement faible des circuits de Dampierre 1 au moment de son arrêt fait l'objet du papier "Aspects contamination pour le RGV". En ce qui concerne la phase de mise à l'arrêt à froid, on peut noter que l'utilisation d'une filtration spécifique (ADF) et les vidanges du circuit primaire ont plus que compensé la recontamination importante apparue lors de la phase d'oxygénation.

Deux procédés différents de décontamination des tuyauteries primaires ont été mis en oeuvre au titre d'expérience pilote: la décontamination par chimie douce du fond de GV et des extrémités des tuyauteries primaires sur une boucle et l'électrodécontamination des extrémités de tuyauteries primaires sur les 2 autres boucles. Le gain dosimétrique net a été de 700 homme.mSiévert soit 25% de gain relatif et un coût de l'homme.rem évité qui, en supposant qu'un seul procédé ait été développé, aurait été d'environ 20000\$ c'est à dire supérieur à la valeur permettant de justifier l'opération.

Les protections biologiques

Il s'est avéré que le matériel existant n'était pas suffisamment adapté à l'opération de RGV. L'ensemble de 56 tonnes de matériels perfectionnés et de qualité qui ont été provisionnés et installés (matelas, paravents, murs, plaques de sol) a eu un impact non seulement sur la motivation des intervenants mais surtout sur le bilan dosimétrique. Le gain net a été de 484 homme.mSiévert (gain brut de 534 homme.mSiévert moins coût d'installation de 50 homme.mSiévert) soit un gain relatif de 20% et un coût de l'homme.rem évité d'environ 8000\$, qui diminuera avec la réutilisation du matériel. Ce gain aurait été supérieur en l'absence de décontamination des tuyauteries primaires.

La contribution des obturateurs hydrauliques mis en place dans les tuyauteries primaires pour les besoins de la décontamination est prise en compte dans le bilan dosimétrique correspondant.

La vidange de l'eau du secondaire des générateurs de vapeur au dernier moment avant leur évacuation a constitué un gain "gratuit" pouvant représenter jusqu'à 900 homme.mSiévert soit 30% de gain relatif s'il est calculé par rapport à une vidange en début d'arrêt.

Les outillages

Pour les 2 opérations les plus longues au contact des tuyauteries primaires, des outillages pilotés à distance ont été spécialement développés : machine à usiner le chanfrein de soudure et ensemble de soudage TIG orbital vidéo.

La préparation et l'organisation

Une optimisation du chantier sur le plan dosimétrique a été possible grâce aux actions de préparation suivantes:

- l'élaboration d'un ensemble de "Fiches Radioprotection" décrivant l'environnement participant à la dosimétrie de chaque tâche et le nombre d'intervenants prévu,
- une revue de projet de l'ensemble des tâches du RGV avec les entreprises concernées,
- un entraînement sur maquette des opérateurs spécialisés les plus exposés, en présence d'un spécialiste de radioprotection.

D'autre part l'absence d'alea de chantier, elle-même largement imputable au haut degré de préparation technique, a fortement contribué à la limitation des doses reçues.

UNE PHILOSOPHIE DE RADIOPROTECTION INDIVIDUELLE

Le type de formation donnée en France aux intervenants permet de limiter fortement le nombre de techniciens de radioprotection nécessaire sur les chantiers. Cette formation a été complétée par une information spécifique auprès des participants à l'opération de RGV (vidéo d'accueil, fascicule "ALARA", information spécifique de l'encadrement d'EDF et des entreprises, affichage des courbes dosimétriques prévisionnelles et réalisées). On a d'ailleurs pu observer une relation inverse entre dose individuelle et degré de formation/sensibilisation à partir d'interviews.

CONCLUSION

Même si on peut attribuer le bon résultat dosimétrique de l'opération de RGV de Dampierre 1 en partie à un état radiologique de la tranche meilleur que prévu, et qui explique par ailleurs 60% de l'écart entre le bilan prévisionnel avant arrêt (4,5 Homme.Siévert) et le résultat final (2,2 homme.Siévert), il n'en reste pas moins vrai que la contribution de l'ensemble des actions menées pour réduire la dose collective a été déterminante; les outils d'optimisation spécialement développés ont même permis de vérifier que les actions de protection ont eu l'impact prévu.

CONTAMINATION ASPECT FOR THE STEAM GENERATOR REPLACEMENT

S. ANTHONI (*), P. RIDOUX (**), J.L. TROHINI (***)

(*) CEA/SECA CADARACHE, 13108 ST PAUL LEZ DURANCE CEDEX - FRANCE

(**) EDF/SEPTEN, 12-14 avenue Dutriévoz, 69628 VILLEURBANNE CEDEX - FRANCE

(***) EDF/DSRE, 6 rue Ampère, 93203 SAINT DENIS CEDEX 1 - FRANCE

The good dosimetry result of 2,13 men Sievert for the three steams generators replacement at DAMPIERRE is the result of an ensemble of dispositions choised for this occasion.

Among them are the contamination aspects of the system.

We can cite, particullary :

- design generally dispositions to permit a reduction politic of the activity of the systems (decreasing of the cobalt content from the steam generator tubes, using of zyrcaloy guid fuel assembly,...)
- the power operation parameters,
- an rigorous procedure for the refueling shut down;

ASPECTS CONTAMINATION POUR LES REMPLACEMENTS DE GENERATEUR DE VAPEUR

RESUME

Le résultat dosimétrique remarquable de 2,13 homme sievert pour le remplacement des 3 générateurs de vapeur de DAMPIERRE est le résultat d'un ensemble de dispositions adoptées à cette occasion.

Parmi elles figurent les aspects contamination des circuits. On peut citer plus particulièrement :

- des dispositions générales de conception permettant une politique de réduction de l'activité des circuits (diminution de la teneur en cobalt des tubes des générateurs de vapeur, utilisation de grille de maintien du combustible en zyrcaloy ...),
- les paramètres de fonctionnement,
- une procédure de mise en arrêt à froid rigoureuse.

CAS DE DAMPIERRE 1

DAMPIERRE 1 est une tranche présentant des niveaux de contamination intéressants, parce que relativement faibles par rapport aux autres tranches du parc, comme le montre la figure 1.

CONTAMINATION

Elle a fait l'objet de mesures spécifiques par le CEA/SECA à l'aide de l'appareil de spectrométrie EMECC (Ensemble de Mesures et d'Etudes pour la contamination des Circuits).

De leur analyse, il ressort que :

- * La conception des générateurs de vapeur (2 fabricants différents) favorise la déposition de produits de corrosion sur les faisceaux tubulaires, ce qui se traduit par une activité déposée sur les tuyauteries du circuit primaire plus faible.
- * L'introduction de grilles de maintien des éléments combustibles en zircaloy a été également un facteur favorable.
- * Le fonctionnement qui comportait, en cours de cycle, un arrêt à chaud de 12 jours, 40 jours avant l'arrêt fin de cycle, a fait l'objet d'un allongement de campagne d'environ 2 mois, avec 1 fonctionnement à 50 % de PN pendant 10 jours.

On peut retenir que la fin de cycle a été globalement bénéfique pour la contamination : on a estimé des gains de 5 à 35 % en activités, par rapport au début de l'allongement de campagne.

- * En ce qui concerne la chimie, un facteur intéressant supplémentaire à retenir : le fonctionnement un peu plus acide en fin de cycle, et 1 choc acide fin de cycle (ph = 6,6), qui favorise les déplacements d'activité hors flux vers les zones sous flux.
- * La mise en arrêt à froid a suivi la procédure habituelle avec quelques gestes particuliers :
 - utilisation d'une filtration adaptée combinant à la fois le piégeage des matières solubles et des particules,
 - globalement, le volume du circuit primaire a été renouvelé 2 fois.

Ces actions ont contribué à une bonne épuration du circuit primaire, bien que leur effet sur la contamination générale ne soit pas pleinement démontrée à ce jour. L'expérience acquise montre en effet que les mises en arrêt à froid sont plutôt des sources de contamination que de décontamination. Par exemple, l'oxygénation qui peut entraîner une redéposition (essentiellement du Co 58) si elle est réalisée à une température trop élevée.

RESULTATS

Par rapport au cycle précédent, on constate :

- une tendance à la baisse sur les activités Co 58 de 25 % sur les GV et 30 % sur les branches chaudes,
- une baisse de l'ordre de 20 % sur les branches chaudes pour le Co 60, au lieu de l'augmentation à laquelle on pouvait s'attendre.

Des mesures en continu ont été effectuées sur les GV 1 et 3 durant les phases de refroidissement, oxygénation et purification. On y constate une recontamination modérée (15 % en Co 58) et une solubilisation presque totale de l'Ag 110 m déposé (1350 GBq pour les 3 GV).

Une analyse est en cours pour déterminer si les parts relatives de la mise en arrêt à froid, de la borication en fin de cycle, ou de la chimie de l'eau sont responsables de cette baisse.

CONCLUSION

Il apparaît comme le démontre DAMPIERRE 1, qu'il faut compter sur un fort impact de la conception sur le niveau de débit de dose.

Néanmoins pour les prochaines opérations de remplacement de générateurs de vapeur, certaines actions peuvent être proposées afin de se placer dans la meilleure position possible :

- introduction de combustible avec des grilles de maintien en zircaloy,
- fonctionnement avec un pH primaire de 7.1, sous réserve des résultats des essais en cours,
- réaliser une bonne épuration de l'eau du circuit primaire pendant les phases d'arrêt,
- être vigilant pendant les phases d'oxygénation,
- utiliser des éléments d'épuration adaptés,
- être vigilants sur le problème des points chauds pouvant affecter des circuits auxiliaires proches du RGV ou éventuellement des boîtes à eau des GV.

DOSE RATE INDEX

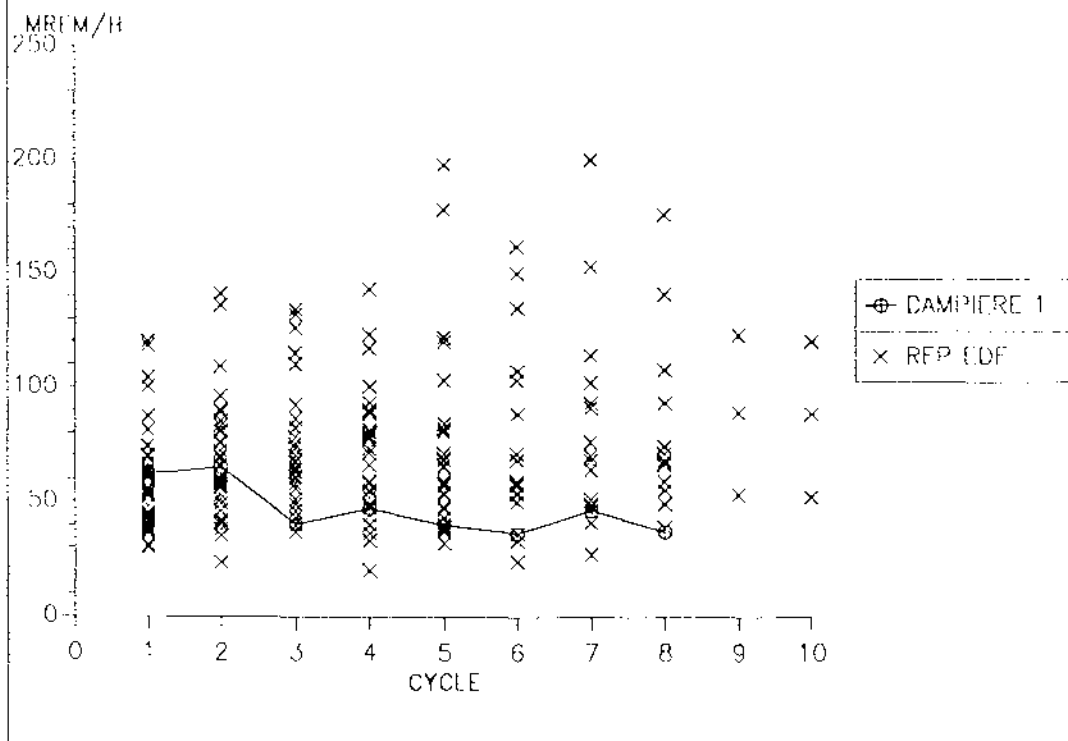

FIGURE 1

Occupational exposure trend and the radiological protection optimization criteria in spanish nuclear power plants in operation:present and future.

O'Donnell, P.

NUCLEAR SAFETY COUNCIL STAFF

ABSTRACT

Occupational collective dose per reactor evolution in the operating nuclear power plants in Spain has shown in the last years a tendency to stability, within a range of values similar to the average of the OECD countries.

In this presentation the main indicators to assess the present development level of this criteria are reviewed and the basis to improve the effectiveness of the practical application of it is proposed.

INTRODUCTION

In this presentation the lecturer reviews the present situation in the application of the radiological protection optimization criteria in Spanish nuclear power plants and proposes the basis to improve the effectiveness of the practical implementation, within the framework of the role played by the regulatory body.

The terms in which this review is done are the following: first, the collective doses and the average individual doses as indicators of the occupational dose trends and, second, the basic components of an ALARA programme, i.e., commitment, organisation, tools and procedures.

OCCUPATIONAL DOSE CONTROL

Concerning dose control two main areas of interest are described within the international context: first, the control of sources of exposures, and second, the control of exposure duration.

A third approach to control doses is to introduce efficient work management programmes including work planning, training, optimization of work forces, etc.

COLLECTIVE DOSE

Occupational collective dose per reactor evolution in the operating nuclear power plants in Spain has shown in the last years a tendency to stability, within a range of values similar to the average of the OECD countries.

Surely, this tendency of the collective occupational dose for Spanish PWR's is far from reaching an ALARA plateau, which is not cost effective to reduce exposure with the current nuclear reactor design and technology.

Comparing the situation for PWR's within the international context, size and age taken into account, we can see according with the data of the table I that while collective occupational exposure in the last generation of spanish PWR's is in a very advantageous level, the behaviour of the second and first generation is different. In this sense,

the third generation incorporates in its designs more ALARA considerations than the others.

TABLE I.- AVERAGE ANNUAL COLLECTIVE DOSES OVER PLANT LIFETIMES AS A FUNCTION OF REACTOR SIZE AND AGE FOR PWR'S (man.mSv).

COUNTRY	OLD & SMALL PLANTS	INTERMEDIATE & MEDIUM	MODERN & MEDIUM
SPAIN (82-90)	5,190 (01)	2,790 (04)	750 (02)
INTERN.AVER. *	2,990 (18)	2,100 (34)	1,660 (22)

* Belgium, France, Finland, W. Germany, Holland, Japan, S. Africa, Spain, Sweden, Switzerland and USA PWR's > 400 Mwe gross output. During the period 1969-88 (Ref. 1).

NOTE: The values in parenthesis are the numbers of reactors in each class. The small plant of Spain is only 160 Mwe gross output.

Similar terms of comparison can be established for BWR's, but, in this case, with the supplier's country of origin. Again, the relative situation on occupational exposure is more advantageous for the new plant than for the old one (Table II).

TABLE II.- AVERAGE ANNUAL COLLECTIVE DOSES OVER PLANT LIFETIMES AS A FUNCTION OF REACTOR SIZE AND AGE FOR BWR'S (man.mSv).

COUNTRY / PERIOD	OLD & SMALL PLANTS	INTERMEDIATE & MEDIUM
SPAIN / 87-89	6,290 (1)	2,600 (1)
USA * / 87-89	5,430 (6)	4,710 (6)

* The lecturer has considered most similar plants in size and age to the Spanish ones (Source: Ref. 2).

NOTE: The values in parenthesis are the numbers of reactors in each class.

TASK RELATED COLLECTIVE DOSE

In order to homogenize dosimetric data, the CSN recommends in its safety guide nº 1.5 "Documentation on refuelling outage in LWR's", Appendix III, a codification system which is the one recognised by the CEC (Doc. nº 3650/90/ES MC/ae), and at the same time the one also included in the data base of the ILO, coordinated by the NEA/OECD.

Following the recolected data up to date, although with various codifications, some of the jobs involving higher average collective doses for PWRs are steam generators (45%), insulation/scaffold (15%), waste and decontamination (8%), open/close vessel(8%), RC pumps (4%), reactor components (2%), refuelling (1%) and others (17%).

INDIVIDUAL DOSES

In Spain this parameter is stabilized on the same order during last five years as the international medium (3 mSv). According to a study developed by the Radiation Protection Working Group of AMYS-UNESA, and the dosimetric data reported to the CSN, only about 5% of the workers were, at least once, over 20 mSv/year during the period of time 1985-89. The average being in the last five years about 2% of the workers

exceeding 20 mSv/year, i.e., between 100 and 170 workers each year. During the mentioned period only 0.25% of the workers were overpassed 100 mSv of cumulative dose, i.e., 42 workers.

IMPACT OF REDUCED EXPOSURE LIMITS AND ALARA IMPLEMENTATION

New ICRP's recommendations emphasize the need to focus the efforts in reducing the sources of exposure and the duration of exposure, by incorporating more means as crew for high dose work, restriction in use contractor's key worker, etc. not implying necessarily an increase in total collective occupational exposure, taking into account that both, individual doses and number of persons exposed, must be optimized.

The optimization criteria is implemented in Spain through "Dose Reduction" programs. The terms under which these programs are going to be reviewed are commitment, organization, tools and procedure.

A key factor then to a succesful ALARA programe is the commitment at all levels, but mainly at management level.

Although a strong commitment from management and the workforce can be enough, a specific management structure are very usefull to strengthen operating efficiency of ALARA program.

In my opinion, must be required the presence in the plants of a specific and permanent structure to cover the following roles and profiles:

- * Multidisciplinary structure at the management level
- * Expert group
- * The radiation protection manager in all plants has direct access to the plant manager and is independent of the operating organization.

On the other hand, the "Dose Reduction Programs" includes the guidelines of an ALARA job review, involving pre-job review, follow-up, post-job review and process review, in similar terms as the INPO considers as a good practice.

Nowadays, the CSN has started a process in order to homogenize the procedures that implement the ALARA program, in accordance with the last requirements related.

Examination of the evolution of exposures associated with routine or special maintenance operations in nuclear power plants normally shows a decreasing trend for collective doses throughout successive operations. This evolution is generally accompanied by a simultaneous reduction of the average individual doses for the various categories of workers involved.

One of the aspects that has an influence in this evolution is the "learning" effect which allows operator to integrate the lessons from previous operations. Studies have also shown that the dosimetric burden of the first operations can be substantially reduced if radiation protection considerations are present at the preparatory stages, as well as during work performance.

When carrying out ALARA assesments during plant operation it is essential to make the maximum use of operating experience. This can only be achieved if plant operator has all available information to estimate the consequences of their choices.

Computerised data base of collective doses and job related doses has been established by the CEC and the NEA/OECD is taking the last steps to set up an International Information System on Occupational Exposure (ISOE), which will process data from America, Europe and Japan utilities.

In Spain, utilities and the CSN will participate in the ISOE project. In addition, the CSN is supervising a historic study of recopilation of data in occupational exposures, job related doses and dose reduction techniques applied in order to provide the initial input to a similar data base on a national context, compatible with the CEC and ISOE data bases.

DOSE CONSTRAINTS

According to the ICRP-60 it may be necessary to establish dose constraints at the national level for operation, inspection and maintenance of nuclear power plants. From my personal point of view, the collaboration among the regulatory organization and utilities is essential to achieve the proper values.

CONCLUSIONS

ALARA must be regarded primarily as a "state of thinking" that should pervade the various levels of management and workforce.

The possibility of specifying valuation of detriment by the national authority is under consideration, but at the moment other actions, as mentioned above, to improve the framework in which the ALARA criteria is developing have been considered more urgent.

REFERENCES

- 1.ANS-1990. "The Control of Occupational radiation Exposure and the Application of the ALARA Principle in Pressurised Water Reactors: an Update for 1989". Burholt, G.D. ANS Report N° 2182-R2, Epsom. Surrey, 1990.
- 2.NRC-1990. "LWR Occupational Dose Data for 1989." Hinson, C., NRC, Washington, 1990.
- 3.ICRP-60."Recommendations of the International Commission on Radiological Protection". Annals of the ICRP. Pergamon Press, Oxford, 1.991.
- 4.CSN-1991."Documentación sobre Actividades de Recarga en Centrales Nucleares de Agua Ligera". Guía de Seguridad n° 1.5. CSN, Madrid, 1991.
- 5.GPR-AMYS/UNESA."Sectorial Studies for Dose Reductions in Spanish NPP". Carmena, P., Iñiguez, J. INPO-WANO Workshop. CN Almaraz, 1991.
- 6.Viktorsson, C., Lochard, J., Benedittini, M., Baum, J. and Khan, T., "Occupational Dose Control in Nuclear Power Plants- An Overview." Proceedings of the International Workshop on New Developments in Occupational Dose Control and ALARA Implementation at Nuclear Power Plants and Similar Facilities. Brookhaven National Laboratory, Upton, New York, September 18-21, 1989.
- 7.Baum, J., "ALARA- Past, Present and Future." Proceedings of the International Workshop on New Developments in Occupational Dose Control and ALARA Implementation at Nuclear Power Plants and Similar Facilities. Brookhaven National Laboratory, Upton, New York, September 18-21, 1989.

LE PROGRAMME RESSAC: BILAN ET PERSPECTIVES

H. Maubert; Ph. Fache; A. Jouve; P. Rongier

CEA, Institut de Protection et de Sûreté Nucléaire
Département de Protection de l'Homme et des Installations
CE CADARACHE, 13108 St-Paul-lez-Durance, FRANCE

E. Schulte

Commission des Communautés Européennes
Direction Générale XII
Rue de la loi, 200, Bruxelles, BELGIQUE

THE RESSAC PROGRAM: PROGRESS AND FUTURE WORK

The RESSAC program (Rehabilitation of Soils and Surfaces after a nuclear ACCident) was started in 1985. It has given since some improved answers to the problem of rehabilitation of radioactively contaminated land. With the involvement of the Commission of European Communities after 1987 and the implementation of collaboration programs with USSR it has an international dimension. In 1992 the scientific teams will be able to use new and important experimental facilities.

1 INTRODUCTION

Depuis les débuts de l'industrie nucléaire quelques accidents ont conduit à des rejets significatifs de radionucléides dans l'environnement. On peut citer les accidents nucléaires de Kyshtym et Windscale (1957), de Tchernobyl (1986) et l'accident radiologique de Goiânia (1987). En France, malgré les précautions prises lors de la conception, la construction et l'exploitation des installations nucléaires, l'analyse de sûreté montre que l'on ne peut pas exclure totalement la possibilité d'un accident grave. Pour gérer au mieux une telle éventualité des plans d'action ont été préparés; il s'agit du Plan d'Urgence Interne (PUI), spécifique à chaque installation nucléaire et sous la responsabilité du chef de l'installation, et du Plan Particulier d'Intervention (PPI), relatif à la phase réflexe de l'accident, et dirigé par le préfet du département concerné. Une fois l'installation remise en état sûr, les pouvoirs publics doivent mettre en application le Plan d'Action Post-Accidentel (PPA), dont les objectifs sont de permettre le retour à une vie normale dans les zones touchées par l'accident.

Au plan national, en cas de crise nucléaire l'Institut de Protection et de Sûreté Nucléaire intervient comme appui technique des autorités de Sûreté et des pouvoirs publics, notamment par l'intermédiaire du Centre Technique de Crise (CTC) implanté à Fontenay-aux-Roses.

Le but du programme RESSAC est d'établir un ensemble de données sur les transferts de la radioactivité dans l'environnement et les méthodes à mettre en oeuvre pour atteindre les objectifs définis ci-dessus. En 1987 la Commission des Communautés

Européennes a été associée au programme. Aujourd'hui l'Allemagne, la Belgique, l'Espagne, la Grande-Bretagne, et l'Italie ont une participation active. Des collaborations sont en cours avec l'URSS pour effectuer des études sur les zones contaminées de Tchernobyl et de l'Oural.

2 BILAN ACTUEL DU PROGRAMME RESSAC

2.1 Les études du terme source et le champ d'action du programme

Le terme source qui a servi à établir l'enveloppe du programme RESSAC (et par ailleurs le PPI et le PPA) a été défini à partir d'un scénario accidentel intervenant sur un réacteur à eau sous pression. Ce terme source, dénommé S3, correspond à une fusion du coeur avec défaillance des systèmes de sauvegarde et utilisation de la procédure ultime de décompression de l'enclaustrage de confinement à travers un filtre à sable. Les produits de fission les plus volatiles (non compris les gaz rares) seraient émis dans l'atmosphère à raison de quelques millièmes de l'inventaire du coeur et les quatre éléments dominants à moyen terme sont, par ordre d'importance décroissante, les césium, strontium, ruthénium et tellures, pour des raisons sanitaires. Des actions de réhabilitation des sols seraient nécessaires sur quelques km² et des restrictions temporaires de consommation de produits végétaux et animaux s'imposeraient sur quelques dizaines de km².

Compte-tenu des incertitudes sur les formes des radionucléides le premier objectif du programme devait être la simulation des conditions de formation du terme source. Le simulateur, appelé POLYR, est un four à induction capable de porter à 3000 °C un mélange de 16 corps représentant le combustible, les matériaux de structure de coeur et les produits de fission. Les aérosols dégagés sont recueillis dans une enceinte chauffée à 60 °C remplie de vapeur d'eau pour simuler les réactions possibles dans le bâtiment du réacteur accidenté. Les aérosols ainsi générés ont été caractérisés: granulométrie, aspect, composition chimique globale, espèces cristallisées et solubilité. On considère que l'objectif de similitude par rapport à un accident réel a été atteint de façon satisfaisante.

2.2 Les documents thématiques

Les distances d'intervention étant définies précédemment il fallait posséder des documents sur l'environnement proche (10 km) des sites électro-nucléaires. Des bases de données ont été constituées. Elles s'appuient sur trois éléments: des cartes d'occupation des sols élaborées à partir de fonds cartographiques existants (Institut Géographique National) des cartes pédologiques, et des cartes de vulnérabilité des nappes d'eau souterraine élaborées en coopération avec le Bureau des Recherches Géologiques et Minières (BRGM).

2.3 Le programme expérimental

Selon les niveaux de radioactivité des terrains contaminés trois types d'actions sont applicables, classées ici des plus

sévères aux plus douces: décontamination par enlèvement physique, contre-mesures chimiques agissant sur le comportement des radionucléides, mesures agronomiques (changement de pratiques) ou agro-alimentaires.

La décontamination par enlèvement physique concerne l'enlèvement de la végétation, le décapage des sols, le nettoyage des surfaces urbaines.

Des expérimentations non radioactives ont été conduites sur des terrains à CADARACHE pour déterminer quelle fraction d'un dépôt d'aérosols microniques serait fixée sur les cultures. Ils s'avère que dans de nombreux cas cette fraction est supérieure à 70, voire à 80 %. L'enlèvement de la végétation revient alors à emporter un pourcentage équivalent du dépôt. Un logiciel (CAPTATIO) a été écrit permettant de calculer ce pourcentage en fonction du type de culture et de sa maturité. Des expériences ont également été faites pour évaluer l'efficacité des techniques d'enlèvement et le taux de remise en suspension des poussières lors des opérations de réhabilitation.

Un logiciel (CATHY2) permettant de calculer la migration des radionucléides dans les sols a été écrit. Cela permet d'estimer l'épaisseur de la couche de sol qu'il conviendrait d'enlever après un dépôt. Les engins de travaux publics tels que profileurs, scrapers, bulldozers, ne sont pas adaptés à l'enlèvement d'épaisseurs inférieures à 5 cm alors que souvent le décapage de 1 ou 2 cm de sol suffirait. Pour cela l'utilisation de mousses polyuréthanes ou de peintures pelables a été testée. Ces produits liquides polymérisent une fois étendus sur le sol où ils forment une couche qui retient en général plus de 80 % du dépôt lors de l'arrachement. D'autres techniques faisant appel à un tapis végétal sont en cours d'étude. L'ensemencement peut se faire par hydrosemis à partir d'un véhicule ou d'un hélicoptère. L'enlèvement se fait à l'aide d'une déplaqueuse à gazon.

Les contre-mesures de nature chimique consistent à modifier le comportement des radionucléides pour diminuer leur transfert dans la chaîne alimentaire. Des expérimentations ont été faites pour établir des expressions analytiques des facteurs de transfert du césium et du strontium aux plantes en fonction de la plante, et de certaines caractéristiques du sol (capacité d'échange, pH, [K] pour le césium et [Ca] pour le strontium). Ce modèle permet de calculer les réductions de facteur de transfert pour Cs et Sr que l'on peut attendre d'un ajout de potassium ou de calcium.

Dans le cadre du programme et sous l'égide de la CCE les équipes de MOL en Belgique et de PIACENZA en Italie travaillent sur les facteurs de transfert fourrage-animaux. L'ajout de sels tels que le Bleu de Prusse à la ration alimentaire permet d'adsorber le césium dans le tractus gastro-intestinal et par là de réduire l'incorporation de ce radionucléide à la viande ou au lait d'un ordre de grandeur dans les meilleurs cas.

Les contre-mesures de nature agronomique et agro-alimentaires sont relativement peu étudiées à l'exception de la mise au point d'une charrue spéciale qui enfouit profondément (0.8 à 1 m) la couche superficielle de sol. Ce travail est fait par le centre de RISO.

3 PERSPECTIVES

3.1 Les documents thématiques

La mise à jour des documents existants par des méthodes traditionnelles est une tâche très lourde. Pour pallier cette difficulté l'équipe RESSAC travaille actuellement sur le traitement et l'interprétation des images obtenues par satellites (notamment par le satellite SPOT) ou aériennes. Cela permettra de planifier des opérations de réhabilitation dans des zones quelconques du territoire, d'évaluer au moment de l'accident l'état de développement du couvert végétal et enfin de réactualiser périodiquement les documents thématiques existants.

3.2 Le programme expérimental

Dans le futur, le programme expérimental se développera dans trois directions:

Sur le terrain on conduira essentiellement des études concernant le dépôt des aérosols par temps humide, comme cela a déjà été fait pour leur dépôt par temps sec.

Dans un bâtiment spécialement construit à cet effet on conduira les essais globaux, qui vont constituer une part prépondérante du programme. Le bâtiment comprendra 4 serres pouvant chacune abriter trois blocs de sols de dimensions $1.8 \times 1.8 \times 1.5 \text{ m}^3$ prélevés sans remaniement et appelés lysimètres. Un climat différent pourra être simulé dans chacune des serres. Les paramètres d'ambiance qui seront contrôlés sont: la température de l'air et des sols, l'humidité, la luminosité, les apports d'eau, le potentiel hydrique dans les sols. Il y aura 4 sites de prélèvements en FRANCE. De plus des lysimètres seront prélevés en Grande-Bretagne, Allemagne, Belgique et Espagne. La source de contamination sera obtenue à partir du four POLYR. Le but de ces expérimentations très réalistes sera de vérifier les modèles de transfert établis précédemment et de tester l'efficacité des contre-mesures envisagées.

En URSS des études sur les zones contaminées, entreprises en collaboration avec des organismes locaux, devraient permettre de tester les méthodes mises au point et de mieux définir les questions de stratégie de décontamination lorsque de vastes étendues sont touchées.

4 CONCLUSION

A l'aide des résultats du programme RESSAC il est déjà possible de proposer toute une variété d'actions de réhabilitation et de contre-mesures. La dimension internationale du programme et les moyens expérimentaux importants qui vont être mis à la disposition des équipes scientifiques devraient permettre une recherche d'un haut niveau de qualité pour optimiser les réponses aux situations de crise.

Enfin, une application de ce programme peut être trouvée dans la réhabilitation de sites industriels déjà contaminés, que ce soit par des radionucléides ou par d'autres polluants tels que des métaux lourds ou des produits organiques.

ON THE STATISTICAL MEANING OF ENVIRONMENTAL MODELS
USED IN DERIVING INTERVENTION REFERENCE LEVELS

F. Breuer (*).L. Frittelli (*), A. Rogani (+)

(*) Italian National Agency for New Technology, Energy
and the Environment, Via V. Brancati 48 00144 ROMA

(+) Istituto Superiore di Sanità, Viale Regina Elena 299
00161 ROMA

ABSTRACT

A stochastic simulation of the (forage, cow milk, thyroid) exposure pathway shows, for a given peak concentration of ^{131}I in cow milk following an acute contamination, a lognormal distribution of the 60 days committed thyroid equivalent dose, with a geometric standard deviation of 2. The statistical variability of the values predicted by environmental models should thus be taken into account for a sound optimization of radiological protection in an emergency situation.

INTRODUCTION

Some important steps are required for environmental modelling (1) in the decisional process of banning milk consumption following an environmental contamination by a radionuclide (e.g. ^{131}I). Usually the adopted model is based on a set of coupled, distinguishable compartments, e.g. anatomical regions, metabolic phases, environmental segments, etc. Analytical solutions for the first order differential equations describing such a system are available but, as the model becomes more complex (but perhaps no more realistic for a given circumstance), numerical methods must be used. If information on the system is incomplete or inaccurate a detailed model is not warranted. The model structure and the form of the equations should be carefully tested and perhaps revised.

MODELLING THE (FORAGE, COW MILK, THYROID) EXPOSURE PATHWAY

Some complex models have been developed for this pathway, with up to twelve or more compartments inferred from the detailed iodine metabolism in cow and in man. The application in a given circumstance of a such very elaborate model, attractive by itself, seems to be justified only when accompanied by accurate and carefully verified values of the input parameters, owing to uncertainty in model predictions associated with uncertainty in the values of each new parameter included. The simplest model which can be acceptably validated is deemed thus more suitable than a more complex model. As an example (Figure 1) the simplified model simulating the (forage, cow milk, thyroid) exposure pathway can be used for estimating, in an emergency situation, the committed equivalent dose in thyroid starting from the measured peak concentration of ^{131}I in cow milk. The transfer constants in the model are simply related (proportional) to the "exposure parameters"

listed in Table 1, which are easy to be measured or estimated in a given exposure circumstance. In the cow model the transfer parameters between the compartments A and B, which should not be given a metabolic or anatomical meaning, have been adjusted to simulate the experimental time behavior of ^{131}I concentration in milk after a single intake, with a peak value between the second and the third day.

If the model adequately represents the situation being assessed, uncertainty analysis by stochastic simulation can be very useful to estimate the uncertainty in the model predictions and to rank the input parameters which more influence them. As a first approximation their values can be inferred from published data, usually in the form of a range into which the actual values distribute themselves as a random sample from an unknown population. An estimated frequency distribution of the values of the relevant parameters should be used to produce a frequency distribution of the model results, to be used together with the "deterministic" results computed from the values assumed for the parameters. Therefore numerical values predicted by the model should be processed as statistical values from an unknown distribution.

PRELIMINARY RESULTS AND CONCLUSIONS

For an effective reduction of the exposure consequences a decision about cow milk banning should be adopted early (within the first two or three days) after the beginning of environmental contamination by ^{131}I . The thyroid equivalent dose $H(60)$ committed over 60 days by the exposed adult member of the public consuming the milk can be computed as

$$H(60) = k_0 * IA(60) = k_0 * C(\text{peak}) * G(\text{peak}, 60)$$

where $IA(60)$ is integrated activity of ^{131}I in thyroid over 60 days, $C(\text{peak})$ is the measured peak concentration, $G(\text{peak}, 60)$ is a factor to be evaluated by means of the model of Figure 1 and k_0 is a suitable factor related to the "exposure parameters" of the model and to specific dosimetric aspects of thyroid irradiation by ^{131}I , as the value of the thyroid mass (Table 1). Owing to the propagation rules of statistics through multiplicative chain models the resulting values of $H(60)$, for a given value of $C(\text{peak})$, could be assumed to follow a probability distribution function related to the statistical distributions of the input parameters, i.e.

$$\text{var}(H(60)) = \text{var}(k_0) + \text{var}(G(\text{peak}, 60)).$$

The variance of k_0 and $G(\text{peak}, 60)$ has been estimated by a Monte Carlo simulation of the model in Figure 1, solving the associated differential equation system by means of a microcomputer program (2). In each simulation run (up to 200) the values of the input parameters are sorted from their statistical distribution around published values (Table 1)(3), assuming a correlation between some parameters (e.g. feeding habits and milk production) for avoiding a full random,

unrealistic sorting, which could produce an unacceptably wide range of predictions. For the transfer constants describing the iodine metabolism in the cow a uniform distribution in the range from 85% to 115% of the input values has been inferred on metabolic grounds to reproduce the observed geometric variance in the forage-milk transfer factor (SGD = 1.2).

Table 1
Standard geometric deviation (SGD) (3) for the model parameters

Weathering half-time for forage	1.4
Forage intake by the cow	2.0
Milk production rate by the cow	1.6
Cow milk intake	1.2
Biological half-time in thyroid	1.8
Iodine uptake by thyroid	1.4
Thyroid mass	1.6

Preliminary results for the probability distribution of the ratio of H(60) to the deterministic value (Figure 2) suggest a SGD value of about 2, with a value around 8 for the ratio of the 95th percentile to the 50th percentile (median). A comparison with previous simulations (2) for ^{137}Cs in cow milk and beef shows the effect of the short radioactive halftime of ^{131}I in reducing the variability of predicted committed equivalent doses. A lognormal distribution (SGD around 1.5) has also been found for the ratio between the ^{131}I peak concentration and the first day value, when sound results of environmental monitoring begin to be available.

The significant rank correlation found between H(60) and "exposure parameters" requires moreover circumstance specific values to be used for the feeding habits and milk consumption rate to avoid biased and misleading results. No such a strong correlation exists with the parameters in the cow model: widespread use of a generic model seems to be justified.

REFERENCES

1. International Atomic Energy Agency, 1989 "Evaluating the reliability of predictions made using environmental transfer models". IAEA Safety Series n.100.
2. Frittelli L., Sanò T., 1989 "Limitations in the models used in deriving Reference Levels for radiological protection" FAO/IAEA/WHO Symposium "Environmental contamination following a large nuclear accident" Vienna 16 - 20 October 1989
3. Frittelli L., Rogani A., 1990 "Analisi statistica dei modelli ambientali" Convegno Nazionale dell'Associazione italiana di Protezione contro le Radiazioni su "Modellistica dei sistemi complessi e Radioprotezione" Sorrento 11 - 13 Settembre 1990

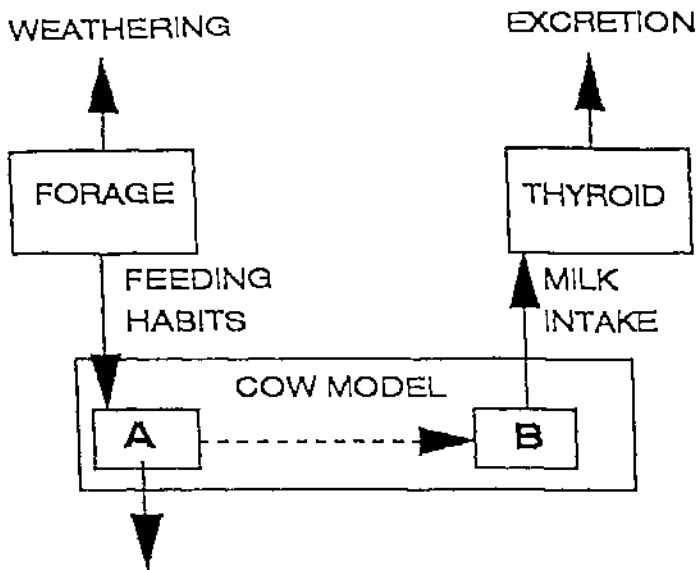

Fig.1 Simplified model of the (forage, cow milk, thyroid) exposure pathway.

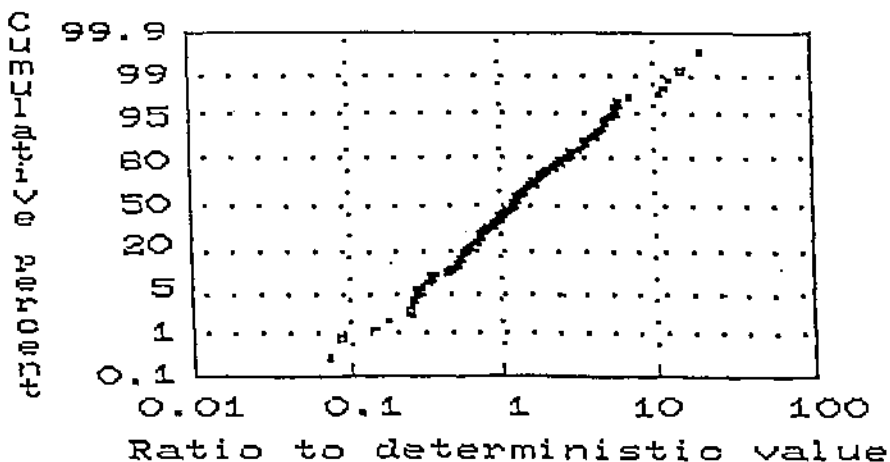

Fig.2 Monte Carlo distribution of the ratios to the deterministic value of the 60 days thyroid committed equivalent dose by ^{131}I in cow milk.

U.S. RECOMMENDATIONS FOR CONTROL OF ACCIDENTAL RADIOACTIVE CONTAMINATION OF HUMAN FOOD AND ANIMAL FEEDS

B. Burnett and M. Rosenstein

Center for Devices and Radiological Health
Food and Drug Administration
Rockville, Maryland (USA)

ABSTRACT

Recommendations for control of accidental radioactive contamination of human food and animal feeds issued in 1982 by the Food and Drug Administration (FDA)⁽¹⁾ are being revised to incorporate current scientific information and radiation protection philosophy, to include experience gained since 1982, and to take into account international guidance. The revised guidance will update the 1982 FDA recommendations regarding protective actions and will provide additional recommendations for limits on radioactive contamination permitted in foods distributed in commerce.

INTRODUCTION

The 1982 FDA recommendations for the control of accidental radioactive contamination of human food and animal feeds are under revision. The revised guidance will be designed to avert risk to the public, in the event of an accidental release of radioactive materials, through: (1) limits on the radioactive contamination permitted in foods distributed in commerce, and (2) preventive actions to mitigate the amount of radioactive contamination reaching the diet. The objective of the revision is to produce a consistent set of guides, applicable to accidental contamination of human food and animal feeds, for use by Federal, state and local agencies in the exercise of their respective authorities.

GENERAL PROVISIONS

The guidance will be for use in radiological emergency response planning and in the conduct of radiation protection activities associated with the production, processing, distribution, and use of human food and animal feeds accidentally contaminated with radioactivity.

An intervention level for radiation dose is included in the guidance and is called the Protective Action Guide (PAG). The recommended PAG in the current draft is 5 mSv (0.5 rem) committed effective dose equivalent with an overriding PAG of 50 mSv (5 rem) committed dose equivalent to an individual organ.

The recommended PAGs are consistent with the approach to the establishment of intervention levels recommended by the International Commission on Radiological Protection (ICRP) in ICRP Publication 40⁽²⁾. ICRP Publication 40 provides general

guidance on the selection of dose levels for the implementation of countermeasures, and indicates that the introduction of countermeasures for the control of foodstuffs would be appropriate within a range of 5 mSv to 50 mSv committed effective dose equivalent and an associated range for committed dose equivalent to individual organs of 50 mSv to 500 mSv . The recommended PAGs are also consistent with the intervention levels of dose selected as the basis for derived intervention levels for foodstuffs established independently by both the Commission of the European Communities and the Joint Food Standards Program of the Food and Agriculture Organization of the United Nations and the World Health Organization. The ICRP included updated concepts concerning intervention in Publication 60⁽³⁾. The application of the concepts in ICRP Publication 60 are currently under development by ICRP.

The revised FDA guidance will provide recommendations on limiting the radiation dose through: (1) limits on the concentration (in Bq/kg) of radionuclides permitted in foods distributed in commerce, called levels of concern, and (2) implementation of various types of protective actions.

The guidance will provide clear advice in advance of an accident, which can be immediately implemented at the onset of an accident. The guidance also will permit the flexibility necessary to respond to unanticipated or unique situations.

LEVELS OF CONCERN

The key feature of the guidance will be the establishment of levels of concern, the limits on the concentrations of radionuclides permitted in food after accidental contamination. The purpose of the levels of concern is to limit consumption of food confirmed as containing undesirable levels of radioactive contamination. Levels of concern are derived concentrations of radionuclides in food, which, if not exceeded, should assure that the PAGs would not be exceeded. In practice, when the levels of concern are not exceeded, the radiation doses to members of the public would be expected to be a small fraction of the PAGs. The levels of concern are being developed for application immediately following an accident; their application would not require early identification of all radionuclides present.

Food with concentrations of radionuclides below the levels of concern would be permitted to move in commerce without restriction. Food with concentrations of radionuclides at or above the levels of concern would normally not be permitted into commerce; however, flexibility would be permitted for special circumstances.

Levels of concern are based on typical quantities of food intake, the fraction of food intake that is assumed likely to be contaminated, and the relationship between radioactivity concentrations in food and radiation dose delivered to the individual per unit of radioactivity intake (i.e. the dose conversion factor).

The relationship between the levels of concern and the PAGs is given by:

$$\text{Level of Concern (Bq/kg)} = \frac{\text{PAG (mSv)}}{f \times \text{Food Intake (kg)} \times \text{DCF(mSv/Bq)}}$$

Where: DCF = the dose conversion factor; the radiation dose per unit of radioactivity ingested (mSv/Bq).

f = the fraction of the food intake that is assumed to be contaminated.

Food Intake = the total quantity of food intake in the time period of concern (kg).

Levels of concern were calculated for twenty three radionuclides and for six age groups using PAGs, DCFs and dietary intakes appropriate to each radionuclide and age group. Calculations were performed for the following age groups: 3 months, 1 year, 5 years, 10 years, 15 years and adult (>17 years). The DCFs used were from ICRP Publication 56⁽⁴⁾. The levels of concern were calculated based on the total annual dietary intake for each age group, not for individual foods or food groups. The calculation also included the assumption that contamination would occur in thirty percent of the total annual dietary intake or sixty day intake for I-131. The value of thirty percent is based on the expectation that less than ten percent of the total dietary intake would consist of contaminated food, and then applying an arbitrary additional safety factor of three. An exception was made for the case of I-131 in the infant diet where the entire sixty day intake was assumed to be contaminated.

The resulting levels of concern were evaluated to identify the radionuclides most likely to be the predominant contributors to dose through ingestion during the first year following an accident. Four radionuclide groups were identified as most likely to be the major contributors: Sr-90, I-131, Cs-134 + Cs-137, and Pu-238 + Pu-239 + Pu-240 + Am-241.

The final structure of the levels of concern to be recommended is still under review. The ease of implementation is a major consideration in the selection of the structure for the levels of concern. For example, one practical approach would be to group the six age groups to represent two population groups: infants (age groups 3 months and 1 year) and all others (age groups 5 years, 10 years, 15 years and adult). Recommended levels of concern for each radionuclide group would consist of two values, one to be applied to foods consumed by infants and the other to be applied to foods consumed by all other members of the population. Another practical approach would present a single level of concern for each radionuclide group which would be applicable to all foods and all members of the population. In either of these approaches, the most limiting level of concern for any of the age groups included in a population group would be selected (i.e. for each radionuclide group).

The guidance will recommend that the levels of concern be evaluated as soon as possible after an accident to insure that they are appropriate for the actual situation. In unique accidents, radionuclides for which levels of concern are not specified may contribute significant radiation doses. There may be other exceptions

or special conditions which could require additional or revised levels of concern. In these situations an evaluation would need to be performed to determine if the PAGs would be exceeded. The guidance will recommend that, when needed, the FDA be consulted for the development of additional or special purpose levels of concern.

The recommended levels of concern apply to the distribution and use in the U.S. of food grown, produced or manufactured in the U.S. Imported foods are currently controlled by existing guidance set out in FDA Compliance Policy. Foods exported from the U.S. are controlled by standards, regulations and guidance adopted by the importing country.

PROTECTIVE ACTIONS

The guidance will present recommendations for mitigating radionuclide contamination through protective actions taken to prevent or reduce the contamination of food and animal feeds or to delay the use of food and animal feeds suspected of being contaminated until the level of contamination can be determined. Many of the protective actions will be similar to those recommended in the 1982 FDA guidance, such as: sheltering livestock and placing them on stored feed, holding food to allow for decay of short half-life radionuclides, and removal of surface contamination. The draft will recommend that protective actions be selected as appropriate to the situation and once initiated, the action or actions continue until such time that, in the absence of the action, the affected food can be expected to meet the levels of concern.

STATUS OF REVISION

A draft of the revised guidance, including proposed values for the levels of concern and specific proposals on the application of protective actions has been circulated to the principal Federal agencies and the Conference of Radiation Control Program Directors for preliminary review and comment.

REFERENCES

1. Food and Drug Administration (1982). Accidental Radioactive Contamination of Human Food and Animal Feeds; Recommendations for State and Local Agencies. Federal Register (47FR47073), October 2, 1982
2. International Commission on Radiological Protection (1984). Protection of the Public in the Event of Major Radiation Accidents: Principles for Planning. ICRP Publication 40, Pergamon Press, Oxford
3. International Commission on Radiological Protection (1991). 1990 Recommendations of the International Commission on Radiological Protection. ICRP Publication 60, Pergamon Press, Oxford
4. International Commission on Radiological Protection (1989). Age-dependent Doses to Members of the Public from Intake of Radionuclides: Part 1. ICRP Publication 56, Pergamon Press, Oxford

MEASUREMENT, ASSESSMENT, AND EVALUATION
WITHIN THE INTEGRATED MEASUREMENT AND INFORMATION SYSTEM FOR
SURVEILLANCE OF THE ENVIRONMENTAL RADIOACTIVITY (IMIS)

A. Bayer, D. Nofke, J. Burkhardt, A. Löbke-Reinl, M. Werner
H. Leeb, K. Jung, C. Wittler, J. Lieser, W. Weiss

Bundesamt für Strahlenschutz, Institut für Strahlenhygiene
8042 Neuherberg, Germany

ABSTRACT

The Integrated Measurement and Information System for the Surveillance of the Environmental Radioactivity (IMIS) is currently being established. The field measurements involve existing Federal and State institutions and organisations. The measured radioactivity data as well as general data from the environment will constitute the foundation on which a series of assessment programs are built like contamination prognoses, models for assessment of radiation exposure, and models for precautionary measures. The data determined by measurement and calculation are so processed that in the case of an event a good evaluation is possible within a reasonable time.

INTRODUCTION

The Integrated Measurement and Information System for the Surveillance of the Environmental Radioactivity (IMIS) is currently being established. In the case of an event with radiological effects this system is determined to quickly supply comprehensive data which enable a rapid assessment of the situation. For this purpose all necessary steps, i.e. sampling, assessment, and representation of data, are coordinated and integrated in an optimal way.

MEASUREMENT

Basically, the Federal measurement networks and the State measurement institutions (Fig. 1) are included in the measurement programs. Those environmental areas showing the far-reaching distribution of radioactive substances (air, precipitation, gamma local dose rate, soil deposit, inland surface waters, North Sea and Baltic Sea) are controlled by the Federal measurement networks. The surveillance of the specific activity in other environmental areas, such as foodstuffs, drinking water, feedstuffs, etc., is carried out by State measurement institutions.

The measurement data determined by the Federal measurement networks are checked for their plausibility by the central laboratories of the Federal measurement networks. After that, the data are transferred to the Central Federal Agency for the Surveillance of the Environmental Radioactivity.

After having passed a first plausibility control, measurement data determined by the State measurement institutions are collected and transferred via the State data centers to the

Central Federal Agency. There they are selected according to environmental areas and forwarded to the guiding agencies carrying out synoptic plausibility checks. Then the data are sent back by the guiding agencies to the Central Federal Agency.

In the case of an event, the data - as far as they concern the air-ground-path - will arrive at the Central Federal Agency in the following chronological order, depending on the measuring method:

- Approximately two hours after measurement has been finished, the on-line-data of the Federal measurement networks will arrive, these include: gamma spectrometry, total-alpha-measurement, total beta-measurement, and gamma local dose rate
- The results of collective measurement (gaseous iodine, precipitation) are transferred daily after sampling and assessment have taken place.
- Within one day the results of the following measurements are also available: in-situ gamma spectrometry, alpha spectrometry, and H-3 measurements.
- It takes several days until the results from Sr-90 measurements are available.

The results of measurement carried out by the State measurement institutions will be available approximately one day later with exception of the Sr-90 measurements for which also several days will be necessary.

ASSESSMENT

On the basis of contamination measurements in different environmental areas prognoses are carried out for the contamination of those environmental areas where the surveillance cannot be effected at the time of the event (example: later ripening fruits).

For the estimation of current as well as future irradiation relevant exposure models are used. These models consider the specific environment of man (e.g. city, rural area, usual living habits (e.g. indoors, outdoors) breathing rates and consuming habits (food basket).

In the case of a radiological event appropriate precautionary measure ensure that the resulting exposure to man is kept below the established limits. These precautionary measures include:

- Prohibition or limitation of food and feedstuff etc.
- Recommendation of special rules of conduct for the population

In order to assess in advance the effectiveness of precautionary measure, models are being developed describing their effect on radioactive contamination or irradiation exposure, respectively

The model described above are integrated in the PARK model which is being developed by the Research Center for Environment

and Health (GSF). This model considers the chronologically registered report of data on the predicted diffusion and of measurement data. The PARK programm consists of the sub-programs AUTOPARK, DIAPARK, and DOSISPARK.

- AUTOPARK automatically calculates for a certain time scale the predicted irradiation exposure for all German administrative districts every two hours in intensive operation.
- DIAPARK is more flexible. all available parameters can be exchanged by the user, e.g. the composition of the food basket can be altered, which leads to correspondingly longer computing time.
- DOSISPARK calculates dose values from measured or predicted contaminations.

EVALUTATION

The results from measuring programs and accordingly developed assessment programs as well as possible additional information are the basis for the situational assessment. The assessment is done by considering the following aspects:

- classifying the situation
 - * observation of the time - and site related process of contamination
 - * comparison with courses of contamination of preceding events
- evaluating the situation
 - * comparison with environmental radiation exposure and its range of variation
 - * estimation of possible radiation damage and comparison with existing manmade exposure risks.

SUMMARY

The establishment of an Integrated Measurement and Information System for the Surveillance of the Environmental Radioactivity provides a system which guarantees the early detection of a radiological event with its consequences for Germany and which by its optimal use produces a rapid, early, and complete assessment of the situation.

REFERENCES

1. A. Bayer, R. Dehos, A. Kaul, G. Wehner, A. v. Gadow, A. Bühling;
Integrated Measurement and Information System for the Surveillance of the Environmental Radioactivity in the Federal Republic of Germany
Nuclear Engineering International 35 (No 427) 47-48 (1990)
2. P. Jacob, W. Jacobi, H. Müller, H.G. Paretzke, G. Pröhl, J. Eklund, J. Gregor, R. Stapel;
Real Time System for the Assessment of the Radiological Impact of Radionuclides Released to the Atmosphere
Nuclear Technology 94, 149-160 (1991)

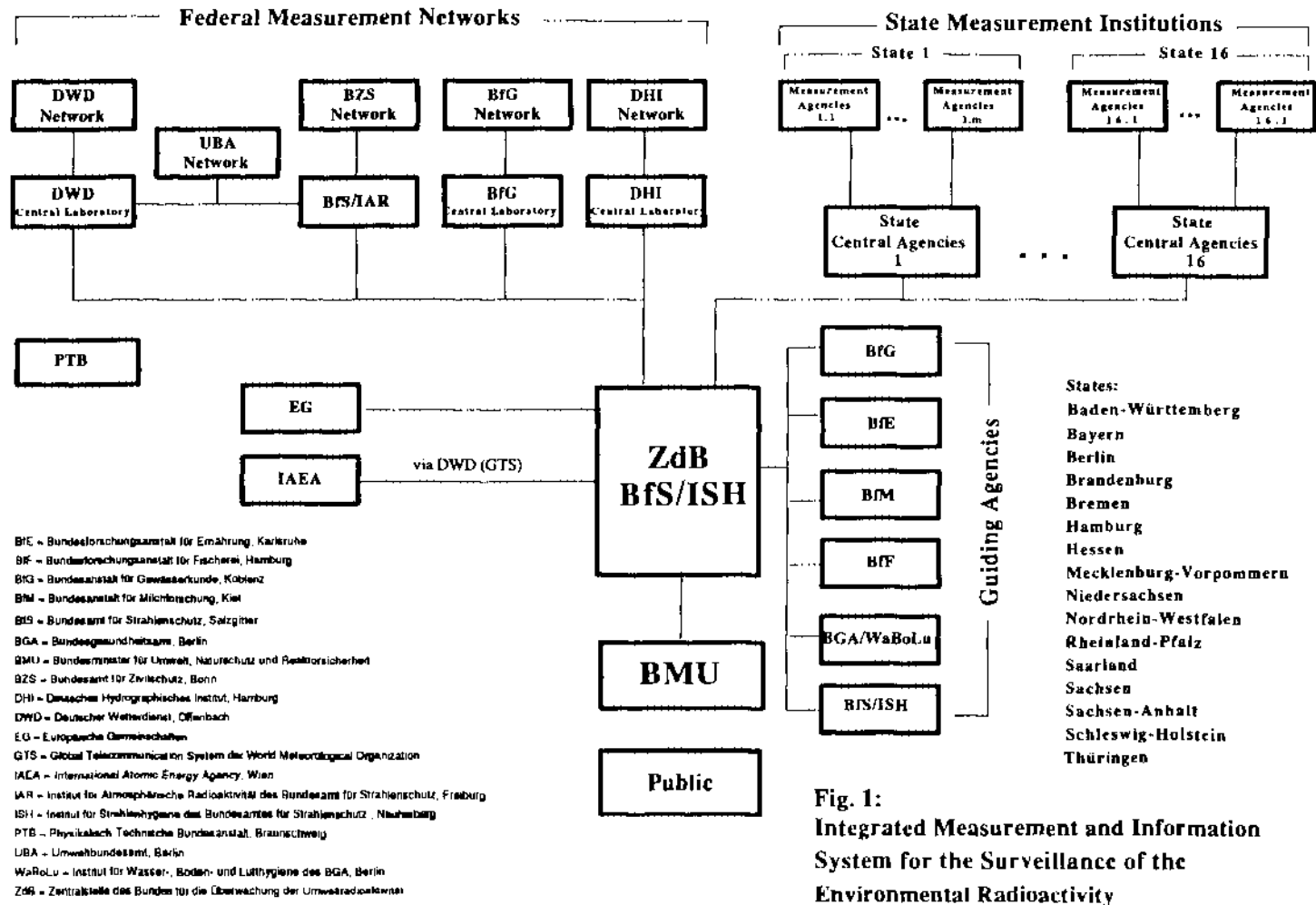

Fig. 1:
Integrated Measurement and Information
System for the Surveillance of the
Environmental Radioactivity

LA MISSION ET LES MOYENS DU SCPRI, SERVICE OFFICIEL FRANÇAIS
DE RADIOPROTECTION, EN CAS D'ACCIDENT NUCLEAIRE

par Pierre PELLERIN, Jean CHANTEUR et Jean-Pierre MORONI

La réglementation française donne au Ministre chargé de la Santé et au Ministre chargé du Travail, *ministères de prévention*, la responsabilité déterminante de garantir, vis-à-vis des travailleurs et de la population, que le développement et l'exploitation de l'énergie nucléaire ne puissent menacer l'hygiène publique ou professionnelle. Cette mission essentielle est, notamment pour le Ministre de la Santé, concrétisée par l'*avis conforme* qu'il est seul à donner pour autoriser le fonctionnement de toute installation nucléaire, ce qui lui confère un véritable *droit de veto* en la matière. Le Service Central de Protection contre les Rayonnements Ionisants (SCPRI) est le "*bras séculier*" des ministères de prévention. Ce point fort du système français confirme que le dernier mot appartient à une autorité exclusivement chargée de la protection de l'homme, *qui n'est pas juge et partie dans la promotion du nucléaire*, ce qui distingue sans équivoque la responsabilité de la radioprotection d'une part, de celle de la *sûreté nucléaire* d'autre part :

LA SURETE NUCLEAIRE garantit la fiabilité technique de la *machine* (réacteurs, usines de retraitement, accélérateurs, etc.). C'est une *responsabilité d'ingénieurs* hautement spécialisés, sur laquelle s'appuie le Ministre de l'Industrie pour promouvoir l'énergie nucléaire.

LA RADIOPROTECTION garantit la *santé des individus* (travailleurs et population). Elle est de la *responsabilité de médecins* qualifiés en radiobiologie, radiotoxicologie et radiopathologie, totalement indépendants des impératifs de production nucléaire, qui conseillent les Ministres du Travail et de la Santé. *La santé passe avant la production d'énergie.*

1°) ROLE DU SCPRI EN CONDITIONS NORMALES : Outre ses missions d'hygiène publique et professionnelle (recherche en radioprotection, établissement des normes, centralisation des données, formation et information, agrément et surveillance de 50 000 installations radiologiques médicales et dentaires, surveillance de l'exposition de 120 000 travailleurs, etc.), le SCPRI assure en permanence le contrôle réglementaire des rejets des installations nucléaires et de leur environnement. Plus de 40 000 échantillons sont analysés annuellement dans ses laboratoires du Vésinet. Ces analyses systématiques, indépendamment des autres dispositions, assurent la détection d'incidents qui auraient pu échapper à l'exploitant.

2°) ROLE DU SCPRI EN CAS D'ACCIDENT NUCLEAIRE : La mission dévolue au SCPRI est primordiale en cas d'accident :

- il assure immédiatement avec ses moyens d'intervention avancés l'essentiel des mesures effectives de la radioactivité sur le terrain, et des analyses fines en laboratoire ;
- il coordonne les autres organismes effectuant des mesures complémentaires sur place ;
- il regroupe l'ensemble des résultats, en assure la synthèse et détermine pour le Préfet, qu'il est chargé de conseiller, les contre-mesures adéquates.

a) Son réseau de télésurveillance du territoire : En situation anormale, les puissants moyens mobiles du SCPRI doivent intervenir le plus tôt possible et au bon endroit. Il faut donc les éclairer par un système de veille permanente aussi performant qu'eux-mêmes. C'est l'objectif des *réseaux de télésurveillance en temps réel* du SCPRI. Ces réseaux du SCPRI totalisent plus de 100 stations, en particulier sur les principaux aéroports français, autour des installations nucléaires, aux frontières, au niveau des préfectures concernées par le nucléaire, etc..

b) Les moyens mobiles du SCPRI : Le SCPRI a développé de puissants moyens mobiles de mesure précise de la radioactivité, entièrement standardisés, pour le contrôle, en cas d'accident nucléaire, des populations, de l'environnement, et des produits agricoles.

Le moyen lourd : c'est une *voiture-rail spectrométrique*, apte à 200 km/h, capable de mesurer simultanément 32 individus ou échantillons (5 000 contrôles par jour).

Les moyens semi-lourds : ce sont deux *semi-remorques* de 20 tonnes dont l'une comporte à la fois 12 postes de mesure (1 500 contrôles par jour, le tiers de la voiture-rail), un laboratoire complet de radiochimie, et un laboratoire de dosimétrie.

Les moyens légers mobiles consistent en 16 "*Master Gemini*" (SCPRI et Services associés) avec chacun quatre postes de mesure (identiques aux précédents). Leur avantage, comme celui des semi-remorques, est d'aller là où le rail ne peut aller, avec une grande souplesse et la même autonomie. Chacun peut effectuer 500 contrôles par jour.

Au total, le SCPRI est capable de contrôler sur le terrain, en cas d'accident, jusqu'à 15 000 personnes ou échantillons par jour en spectrométrie gamma.

CARTOGRAPHIE PAR HELICOPTERE DES DEPOTS RADIOACTIFS AU SOL EN SITUATION ACCIDENTELLE

J. CORTELLA - C. BOURGEOIS - R. CHASTEL - A. ROSENBERG
CEA/SERVICE DE PROTECTION CONTRE LES RADIATIONS

Helicopter mapping of ground radioactive deposition in post-accidental situations.

In post accident situations where a release has resulted in the deposition of radioactive materials on the soil, it is essential to take contamination measurements immediately after the accident and throughout the recovery operations. A description is given of measurement equipment which has been developed in France for performing efficient measurements over large areas : it includes a gamma mapping device and an in situ gamma spectrometry system. These are compared and their use is described.

INTRODUCTION

Après un rejet accidentel ou une dispersion de matières radioactives, la mise en place de contre-mesures et la conduite des opérations supposent la connaissance préalable de la contamination déposée sur le sol et donc des mesures pour :

- faire le diagnostic initial
- suivre l'évolution de la situation

Un des moyens pour répondre à cet objectif est la détection gamma hélicoptérée.

Le système de cartographie gamma qui a été développé est constitué :

- d'un équipement embarqué à bord d'un hélicoptère léger pour l'acquisition des données,
- d'un équipement à terre qui, à partir des données acquises en vol, restitue la carte de la contamination.

Principe de l'acquisition des données en vol.

L'hélicoptère effectue au dessus de la zone à mesurer un balayage selon des trajectoires prédéterminées. Chaque seconde, on enregistre :

- le spectre gamma provenant du scintillateur NaI sur 256 canaux
- la position de l'hélicoptère : altitude par rapport au sol, coordonnées dans un système rectangulaire

Les données de positionnement peuvent être calculées par rapport à la position de balises préalablement disposées au sol. La bonne précision de localisation permet d'effectuer un balayage très serré et la surface cartographiée en une seule opération est de quelques km² à quelques dizaines de km².

On utilise aussi un autre système de localisation pour des grandes surfaces. Il utilise un ensemble de navigation par radar Doppler et permet l'examen de surfaces de plusieurs centaines de km², avec bien entendu une résolution spatiale inférieure.

TRAITEMENT DES DONNEES :

Le traitement des données enregistrées en vol s'effectue après le retour de l'hélicoptère au sol. Il utilise un matériel informatique transportable qui restitue une carte en couleurs de la contamination au sol. Selon le traitement choisi on peut obtenir la contamination caractéristique d'un radioélément donné ou encore la carte des débits de dose.

CARACTERISTIQUES OPERATIONNELLES.

La sensibilité du système est fonction de plusieurs paramètres :

- le rendement d'émission et l'énergie des rayonnements émis par le radioélément recherché (seuil en énergie : 50 keV)
- le bruit de fond dû à la radioactivité naturelle liée à la nature géologique des terrains

Pratiquement, pour un hélicoptère volant à 40 m et à 70 km.h⁻¹ on détecte des "taches" de ¹³⁷Cs ayant une activité égale ou supérieure à 2 kBq.m⁻² et une surface minimale de 2000 m² ou encore des sources ponctuelles de l'ordre 4 MBq.

Le matériel est mis en oeuvre par une équipe de 4 personnes. L'équipement de l'hélicoptère nécessite 1 à 3 h, 1,5 h de vol pour examiner une surface de quelques dizaines de kilomètres carrés, et 2 h environ pour obtenir les premières cartes de la contamination.

SPECTROMETRIE GAMMA IN-SITU :

Ce moyen est complémentaire de la détection gamma par hélicoptère.

Il est constitué d'une diode Germanium HP installée sur un mât télescopique (3 à 9m), lui-même monté sur un véhicule tout terrain.

Il est possible de mesurer des activités très faibles de l'ordre de 0.5 kBq.m⁻².

CONCLUSION :

Les matériels décrits cartographie gamma par hélicoptère et spectrométrie gamma in-situ, présentent, grâce à leur souplesse et leur efficacité un progrès très important pour les mesures à réaliser après un accident radiologique surtout quand on les compare aux méthodes utilisant des appareils portatifs.

D'autres utilisations de ces moyens sont envisageables : établissement de la situation radiologique sur les sites avant la mise en service des installations nucléaires, surveillance de l'environnement pendant le fonctionnement de ces installations, recherche de sources ponctuelles, etc...

Référence :

A.ROSENBERG : aerial gamma mapping - septembre 85

CONCENTRATION OF STABLE CESIUM IN CALF SERUM

N. Ito

Department of Veterinary Radiology,
School of Veterinary Medicine and Animal Science,
Kitasato University, Towada, Japan

ABSTRACT

To analyse the relationship between cesium concentration of serum and age, stable potassium, cesium, and rubidium in cattle serum were measured. The calves and the adult cattle used in this work had been fed under almost the same condition. The cesium concentration of calf serum gradually decreased with the number of days after birth, then was maintained stationary level (0.4 - 0.6 ng/ml, one third of initial value) after 200 days. The rubidium concentration changed like cesium; however, the vivid change was not observed in potassium.

INTRODUCTION

Cesium-137 and Cesium-134 are the most important radionuclides after the short life nuclides have decayed, and livestock products are the largest contributor of the radiocesium to the diet, therefore many investigators made efforts to obtain the transfer coefficients (feed to milk F_m , feed to muscle F_f). Since it is difficult to feed the forage containing radionuclides to adult cattle, young cattle has been used widely for the experiments. Although the F_f of radiocesium of young cattle is higher than adult, the young-to-adult correlation factor has not been published. In this work, stable potassium, cesium, and rubidium in cattle serum were measured, and the relationship between cesium concentration of serum and age was considered.

EXPERIMENTAL

Twenty female calves aged from 100 days to 360 days (Japanese Shorthorn 10, Angus 10), and 45 female cattle aged from 1 year to 10 years (Japanese Shorthorn 25, Angus 20) were used. They were fed on the same forages, and their blood samples were drawn on the same date from jugular vein. The serum was separated from the whole blood by centrifugation, and was powdered by freeze-drier. Approximately 0.1g of the powder was weighed into a high-pure quartz ampoule and sealed. NBS Bovine Liver (SRM 1577) and Oyster tissue (SRM 1566) standards were prepared similarly.

Samples and Standards were irradiated in the JRF-4

reactor (Thermal neutron flux; $5.5 \times 10^{13} \text{ n} \cdot \text{cm}^{-2} \cdot \text{s}^{-1}$) of the Japan Atomic Energy Research Institute for 6 hours. The irradiated samples and standards were counted for 4 hours using a Canberra 30% HPGe detector coupled to a Canberra Series 35plus MCA after cooling for 4 weeks (rubidium), and after cooling for 2 months (cesium).

Potassium was measured by flame emission spectrometry without freeze-drying.

RESULTS and DISCUSSION

Averages of potassium concentrations of serum of adult cattle (>1year) were lower ($p < 0.05$, Japanese Shorthorn: $p < 0.01$, Angus; T-test) than calves. It is known that there is significant negative correlation between human age and potassium concentration of serum. However, there was no significant difference between adult cattle and calves on rubidium and cesium.

Figure 1 shows the change of the cesium concentrations in calf serum. It was the youngest calf (100 days) in this work that had the highest serum concentration of cesium (about 1.6 ng/ml). And the cesium concentration of serum gradually decreased with the number of days after birth, then was maintained stationary level (0.4 - 0.6 ng/ml, one third of initial value) after approximately 200 days. The average serum cesium concentrations of adult cattle were $0.62 \pm 0.20 \text{ ng/ml}$ (Japanese Shorthorn) and $0.59 \pm 0.19 \text{ ng/ml}$ (Angus) respectively, and there is no difference between both breeds.

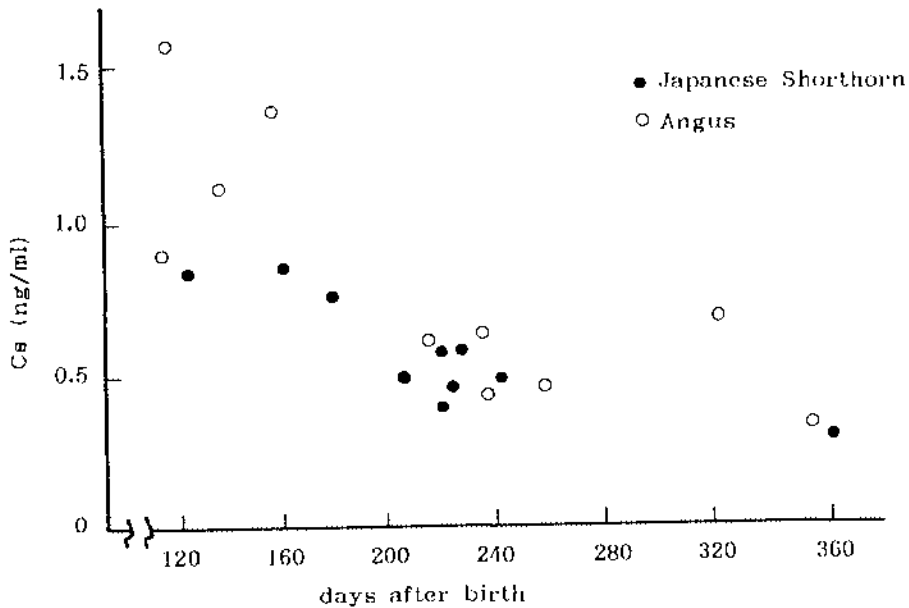

Fig.1 The changes of cesium concentration of calf serum.

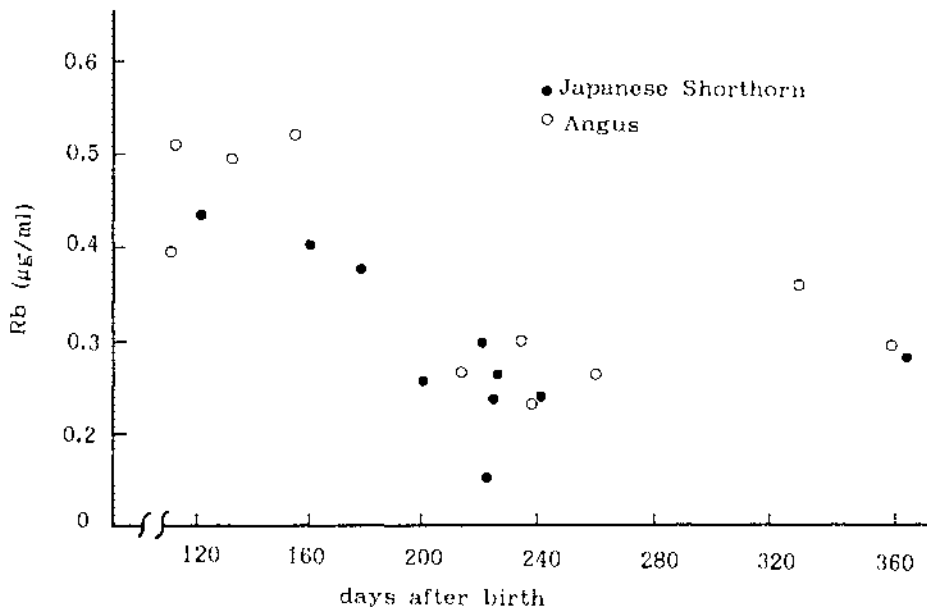

Fig.2 The changes of rubidium concentration of calf serum.

In Figure 2, the change of the rubidium concentrations of calf serum is shown. The rubidium concentrations of serum were three orders of magnitude larger than the cesium. However the rubidium concentration changed almost the same manner as cesium. The average rubidium concentrations of adult cattle serum were $0.31 \pm 0.08 \mu\text{g}/\text{ml}$ (Japanese Shorthorn) and $0.32 \pm 0.06 \mu\text{g}/\text{ml}$ (Angus), and the rubidium concentrations of adult cattle were approximately a half value of the 100-day-old calf.

In potassium concentration of calf serum, the vivid change like cesium and rubidium was not observed.

The calves and adult cattle used in this work had been bred under similar condition in the same stock farm, and were drawn blood simultaneously. So the cesium and rubidium concentrations of serum were kept stationary levels in adult cattle. In the calves, Both cesium and rubidium concentrations of serum gradually decreased with the number of days after the birth. It is known that the orally taken radiocesium is mostly absorbed in the alimentary tract. Therefore it is supposed that cesium and rubidium are absorbed easily at the intestine and/or are scarcely excreted before 200 days.

It is speculate that Ff of calf (<200 days) is two or three times higher than adult cattle on radiocesium.

REFERENCES

1. Lacourly, G., C. Savy, et al., 1971, Relation Between the Radiocesium Contamination of the Meat and Milk from Cows, Health Phys., 21, 793-802.
2. Sirotkin, A. N., et al., 1970, The Behavior of Strontium-90, Cesium-144, Ruthenium-106, Antimony-125, and Zirconium-95 in Cattle, Radiobiology, 19(4), 238.
3. Sirotkin, A. N., et al., 1972, Kinetics of Cesium-137 in Cattle, Medical Publishing House, Moscow, 151, AEC-tr-7457, pp.225-229.
4. Burov, N. I., et al., 1973, Migration of Cesium-137 in the Ration-Farm Animals-animal Husbandary Products Chain, Akad. Nauk SSSR, Komi filial, USSR, 147-148
5. Behne, D., and Geßner, H., 1987, Effect of Dietary K on the Absorption and Excretion of Radiocesium in the Rat, Health Phys., 53, 331-332.
6. Leggertt, R.W., and Williams, L. R., 1988, A Biokinetic Model for Rb in Humans, Health Phys., 55, 685-702.

ACKNOWLEDGEMENT

I am indebted to Mr. I. Kunugiyama and Mr. T. Asami for their support.

MEASUREMENT IN THE FIELD OF THE CONCENTRATION
OF GAMMA EMITTERS NUCLIDES IN SOIL

Bortoluzzi S., Giacomelli R., Montalto M., Nocente M.,
Spezzano P.

ENEA - AREA AMBIENTE - DIPARTIMENTO ANALISI E MONITORAGGIO
MASAL - C.R.E. SALUGGIA - ITALY

SUMMARY

The measurement of the gamma emitter radionuclides is quicker if direct field gamma spectrometry is used. The operations of setting and determination of the parameters necessary for the calculation of the results are described below. Furthermore, the good agreement between the results obtained by the direct measurement and those obtained by the sampling and the subsequent measurement in the laboratory, is shown.

INTRODUCTION

The methodology for the determination of the radionuclides, present in the soil, by direct gamma spectrometry or in situ gamma-ray spectrometry was developed by the Health and Safety Laboratory (HASL) by Beck [1]. The advantages of this analysis technique awakened the interest of our laboratory. We decided to carry out a personal estimation of the method, so as to identify its real good qualities and disadvantages and the operating capabilities within the activities of our laboratory in the best way.

STRUMENTATIONS AND METHODS

In our case, we used a portable, type n, high-purity Ge detector. The detector was located on an adjustable tripod, so modified as to allow the adjustment of the height of the detector from the soil, and the correct positioning in respect of the horizontal plane. The instrumentation is completed by a portable multichannel analyzer and a portable computer for spectrum storage and processing.

The detector has to be located on an enough free and plane soil. The areas troubled by houses or other buildings and the tree-full or not really plane areas are to be avoided. Furthermore, if studies about the depositions of fall-out radionuclides should be carried out, the investigated soil must not be subjected to any human activity, which might have modified washing off of radionuclides or soil depletion by erosional processes.

During our tests, the detector-to-soil distance was set at approx. 1 meter; so, the useful area can be considered to be approx. 10 meters with a depth of 15 to 30 cm, depending upon the energy of the incident gamma rays [2].

DESCRIPTION OF THE METHOD

The area of a peak in an obtained spectrum represents a fraction of the integral of the incident gamma radiation flux, during the acquisition time, on the detector.

We can express the ratio between the gamma radiation, measured by the detector, and the specific activity of the radionuclide in the soil (N_f/A) by the equation by Beck [1]:

$$\frac{N_f}{A} = \frac{N_0}{\phi} \cdot \frac{N_f}{N_0} \cdot \frac{\phi}{A}$$

The determination of N_0/ϕ , intensity of gamma rays measured by the detector per incident flux unit parallelly to the symmetry axis of the detector, in respect of the energy of the incident gamma rays, is carried out experimentally. We used punctiform gamma rays sources having known activity, located 1 meter far from the detector, so that the radioactive flux, which acts on the detector is approximately parallel to its main axis. The trend of N_0/ϕ is obtained by the following function:

$$\frac{N_0}{\phi} = e^{-\alpha} \sum_{n=0}^3 a_n \ln(E)^n$$

The second quantity corrects the detector response to the energy-range of gamma rays for the flux, which do not acts orthogonally to the surface of the detector. Low-energy gamma (<150 keV) excluded, N_f/N_0 remains around the unit. In Helfer's work [2], those values are plotted in respect of the ratio between length and diameter of the german crystal of the detector and the energy of considered gamma rays.

To calculate the values of the incident gamma radiation flux on the detector (ϕ/A), we assumed the geometry of the 2π or semi-infinite source, by eliminating the absorption and local relief problems. The flux depends upon the peculiar distribution of the gamma emitter radionuclide in the soil. The concentration of the gamma emitter per surface unit is considered to be constant on the x-y plane, and having an exponential profile along the z-axis or depth.

The parameter α gives a values of the variation of the concentration by the depth, extreme situations are for $\alpha \rightarrow \infty$ a surface distribution, and for $\alpha=0$ a homogeneous distribution of the radionuclide in the soil.

For any value of α , the total gamma radiation flux, having energy E, at a distance h from the soil, we calculated by approximation by numerical calculation the solution of the integral mentioned by Beck [1].

DISCUSSION

In the method proposed, one has to estimate the dependance of the performed estimation upon parameter choice, and the degree of accuracy which is demanded for the value. The final result will be affected by the highest possible compliance of the characteristics of the measurement point with the conditions which support the model formulation, and by the errors, which are connected to the determination of every parameter.

In general, the careful planning and estimation of the characteristics of the measurement point in respect of the good quality of the results, which one would obtain, allows the optimization of the method.

However, it is necessary to take into account, that, if the assumption of a homogeneous distribution for the natural radionuclides, or surface distribution for a recent fall-out settling gives, in general, satisfactory results, for the estimation of settling due to past events (Chernobyl), the results are affected by the determination of the vertical distribution profile of the radionuclides in the soil. Unfortunately it is not possible to estimate a undependently upon one of

the parameters used. This is the true limit of the method; in fact, if a good accuracy is required, we are obliged to carry out an independent measurement campaign, by collecting core soil samples, which need to be analyzed in the laboratory for the determination of parameter α . To confirm if performed calibrations are good, we performed a set of comparisons. We chose unworked soils, complying with mentioned requirements, performed one or more direct measurements, and, then, the drawing of four or five soil surface samples (depth 30 cm) all around a 10 meters radius from the measurement point. Collected samples were analyzed by the traditional method, i.e.: drying and homogenizing of the soil, measurement by Ge detectors in unsealed Marinelli's container, to prevent balancing between radionuclides of the natural series, and determination of the radionuclides concentrations (figure 1). [3]

Activity τ

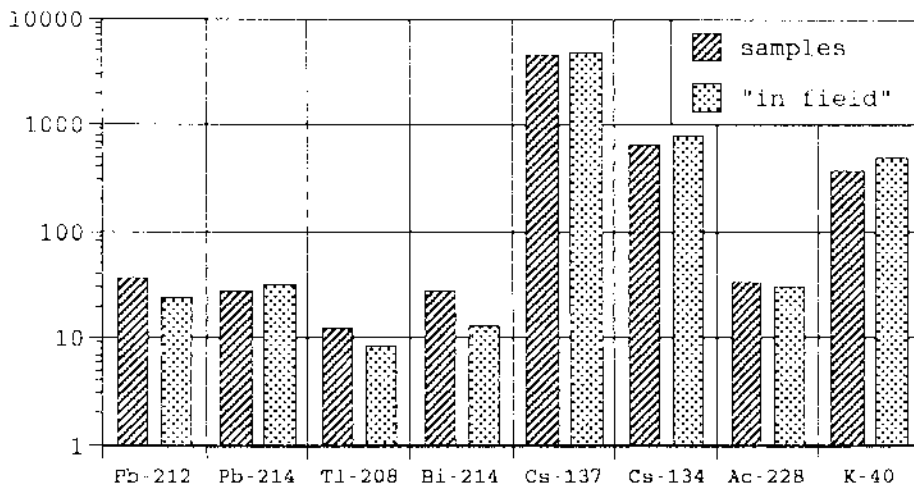

† Bq/kg for natural radionuclides
Bq/mq for fall-out radionuclides

figure 1 - Comparison between calculated activity of Viverone (VC-Italy) soil for the two method

CONCLUSIONS

To sum up, the field spectrometry technique allows a monitoring or research laboratory to have a valid and enough accurated methodology for the immediate estimation of the activity present in the soil. It is specially useful in those emergency situations, where a quick response about soil deposition is required. In that particular situation, the instrumentation supplies, during the same time, more complete and detailed information than usual procedures.

BIBLIOGRAPHY

- [1] H.L. Beck et alt. - *In situ Ge(Li) and NaI(Tl) gamma-ray spectrometry* - HASL 258 (1972)
- [2] I.K. Helfer, K.M. Miller - *Calibration factors for Ge detectors used for filed spectrometry* - Health Physics vol.55 (1988)

- [3] L. Bramati, C. Maffei, G. Pandolfi - *In situ gamma ray spectrometry in accidental situations: potentiality and limitations* - International Symposium on Environmental Contamination following a Major Nuclear Accident - IAEA-SM-306/23P.

Results of the ENEA intercomparison campaigns for the radioactivity surveillance network in Italy

De Felice P.*, Laitano R. F.*, Piermattei S.** and Pona C.*

* Laboratorio di Metrologia delle Radiazioni Ionizzanti (LMRI)
ENEA, C.R.E. Casaccia, cp 2400, I-00100 Roma, Italy

** ENEA-DISP, via V. Brancati 48, I-00144 Roma, Italy

Abstract

A quality assurance programme for activity measurements in environmental samples was established by ENEA since 1982. The programme was based on intercomparison campaigns in which the participants were the laboratories of the radioactivity surveillance network in Italy. The results so far obtained show the effectiveness of these intercomparison campaigns in improving the measurement reliability of the participating laboratories.

1. Outline of the intercomparison campaigns

To assure uniformity and reproducibility of measurements carried out by the laboratories of the radioactivity surveillance network in Italy, the ENEA established since 1982 a standardization programme that is based on periodical intercomparisons on radioactivity measurement. Since the beginnings four intercomparisons have been so far carried out with a number of participant laboratories ranging from 12 to 40 about, according to the evolution of the network in the years. From 1983 to 1985 two intercomparisons were made with the objective to determine the activity concentration of ^{137}Cs and ^{90}Sr in spiked samples of milk by gamma spectrometry and beta counting, respectively. The aim of the first comparison (1983) was to obtain a preliminary information on the accuracy of radioactivity measurements currently made by the laboratories of the network. A second comparison (1985) was repeated in similar conditions to check the long term reproducibility of these measurements. Both the intercomparisons showed a not satisfactory degree of uniformity among the laboratories. The inadequacy of calibration procedures and of data handling was identified as one of the major error sources and this indicated the need to undertake further intercomparisons only after a calibration campaign for the laboratories involved. The validity of this indication was confirmed by the better uniformity obtained in the third comparison (1988), made after a calibration campaign. On the basis of these results a new standardization programme was defined. It is characterized by periodical calibrations and comparisons with a variety of radionuclides in different experimental conditions. According to the revised programme, a fourth

comparison was carried out in 1990 and the last one, started in 1991, is still in course.

Gamma spectrometry was performed by participants mainly by equipment based on HPGe and Ge(Li) detectors. However at the early stage of the intercomparison campaigns some of the laboratories were using traditional NaI-spectrometers. One of the positive effects of this standardization programme was to achieve a fairly homogeneous condition in the experimental equipment.

As for the beta counting, all the participants utilized low-background anticoincidence systems with different types of detectors.

2. Intercomparison procedures

The procedure of each intercomparison was agreed in preliminary meetings between the organizers and the participants. This was considered important to assure that the technical procedures proposed by the organizers could have been easily accepted and applied by each participant. The sources for the intercomparisons were prepared and distributed to the participants by the ENEA-LMRI, the national standards laboratory.

The radionuclides considered in the 1983-1985 comparisons were ^{137}Cs and ^{90}Sr for gamma spectrometry and beta counting, respectively, with an activity level of about 10 Bq/kg.

The experimental conditions regarding the 1988-1990 intercomparisons were rather different with respect to the previous intercomparisons. After the Chernobyl event, it was decided to increase the activity concentrations of the intercomparison sources by more than one order of magnitude with respect to the pre-Chernobyl conditions. The radionuclides considered for the gamma spectrometry intercomparisons were: ^{241}Am , ^{57}Co , ^{134}Cs , ^{137}Cs , ^{54}Mn , ^{88}Y , ^{65}Zn . For beta measurements, sources containing only ^{90}Sr and ^{90}Y at equilibrium were considered. In order to analyze the error sources due mainly to measurement procedures and data handling, it was decided to exclude sample treatment in the comparisons. Therefore the sources distributed to participants were aqueous radioactive solutions. In each intercomparison the participants were given a questionnaire, previously agreed, to be filled in with the measurement results and with a detailed description of the experimental means and of the method they used. The most relevant data to be reported in the questionnaire were: nuclear parameters used for data production, gross and net counting rates, counting time, detector efficiency, minimum detectable activity and the activity concentration of the intercomparison source with related uncertainties.

3. Calibration procedures

The objective of the periodical calibration was to assure traceability of radioactivity measurements to the national (and international) standards.

The not adequate instrument calibration was one of the major error sources in the 1983-85 intercomparisons. Therefore a periodical calibration campaign was agreed among the laboratories before starting any new intercomparison.

The radioactive sources used for calibration were prepared and standardized by the ENEA-LMRI. The standard sources were aqueous solutions prepared according to the same procedures as for the intercomparison sources. The following radionuclides were used to prepare the standard sources for calibration of gamma spectrometers: ^{241}Am , ^{109}Cd , ^{57}Co , ^{139}Ce , ^{113}Sn , ^{85}Sr , ^{137}Cs , ^{88}Y and ^{60}Co . These radionuclides are such to cover the photon energy range more frequently considered for gamma-ray spectrometry in environmental samples. The activity concentration of each radionuclide was about 400 Bq/kg.

The calibration sources used for beta measurements contained ^{90}Sr and ^{90}Y at equilibrium similarly to the intercomparison sources. The activity concentration of ^{90}Sr was about 15 Bq/g.

A peculiar aspect of the calibration procedures was the adoption of the same experimental condition (e.g. the same Marinelli beaker for a given laboratory, and the same source density for calibration and intercomparison measurements). This had a clear effect in error reduction.

Table 1 - Gamma spectrometry intercomparisons from 1983 to 1990. Deviations (%), from the reference value, of the activity concentrations determined by participants. The ^{137}Cs was not included in the 1990 comparison.

lab code	1983 ^{137}Cs	1985 ^{137}Cs	1988 ^{137}Cs	1990 ^{54}Mn	lab code	1983 ^{137}Cs	1985 ^{137}Cs	1988 ^{137}Cs	1990 ^{54}Mn
1	+2.8	+1.7	-	+3.6	14	-	-	-5.9	+2.4
2	+5.6	-3.3	-	+2.8	15	-	-	-6.7	-2.1
3	+5.6	+2.3	-	-4.4	16	-	-	-1.2	+5.1
4	+11	+3.3	-	+4.3	17	-	-	+5.0	+3.0
5	-2.8	-1.9	-	-	18	-	-	+0.9	+2.2
6	+3.3	+1.6	-	-	19	-	-	-0.9	-3.2
7	-4.7	+0.0	-0.6	+1.7	20	-	-	+1.3	+5.4
8	-2.8	-3.3	-	+2.4	21	-	-	-5.8	+2.8
9	-1.9	-0.0	-	+4.2	22	-	-	-0.5	-3.9
10	-1.9	+1.2	-	-2.6	23	-	-	-2.2	+0.0
11	-9.3	-7.4	-9.0	-	24	-	-	+8.8	-2.1
12	+4.9	-	-	+2.3	25	-	-	+5.7	+0.9
13	-	+4.9	-3.0	-	26	-	-	-0.5	+2.1

4. Results and Discussion

The results of the first intercomparison, carried out in 1983, confirmed that the degree of standardization in radioactivity measurements was on average rather poor for the laboratories of the network. The second comparison has shown a slight improvement, but a still not satisfactory situation with regard to the reproducibility of measurements performed by each laboratory.

In both comparisons the major source of error was a not adequate and uniform calibration practice of the experimental means. In addition, the procedures for the assessment of the uncertainties were found dissimilar among laboratories and not exhaustive. The calibration campaign performed in the 1988-1990 intercomparisons resulted fairly effective. After these campaigns the deviation of the results from the reference values were confined in the $\pm 10\%$ limits in more than 90% of cases, for both gamma spectrometry and beta counting intercomparisons.

Table 2 - Beta counting (^{90}Sr) intercomparisons from 1983 to 1990. Deviations (%), from the reference value, of the activity concentrations determined by participants.

lab code	1983 ^{90}Sr	1985 ^{90}Sr	1988 ^{90}Sr	1990 ^{90}Sr	lab code	1983 ^{90}Sr	1985 ^{90}Sr	1988 ^{90}Sr	1990 ^{90}Sr
1	-2.5	+1.0	-	+0.7	7	+23	+39	-	-6.3
2	-9.6	+36	-	-7.3	8	-	-2.0	-3.0	-
3	-17	-29	-	+4.7	9	-	+3.9	+1.2	-2.7
4	-11	+9.2	-	+1.0	10	-	-	-5.4	+6.4
5	-26	-16	-	-	11	-	-	-1.3	-1.4
6	-25	+7.8	-	-15	12	-	-	-1.2	+3.7

Table 3 - Improvement in the deviations from the reference value, in the course of the intercomparison campaigns from 1983 to 1990. The data in percent represent the percentage of results with deviation larger than 10% from the reference value.

period	1983	1985	1988	1990
type of measurement				
Gamma spectrometry	33%	33%	10%	8%
Beta counting	63%	55%	16%	4%

Some typical results are summarized in Tables 1,2 and 3. The details on source preparation and characteristics, on the questionnaire content and on the results concerning all other radionuclides not referred to in Tables 1 and 2, are reported elsewhere (1,2). The intercomparisons planned for the future will be based on radioactive sources in natural matrix other than water.

References

- 1) De Felice P., Laitano R.F., Piermattei S., "Activity measurements of ^{90}Sr and ^{137}Cs in spiked solutions of milk. Results of a national intercomparison in Italy", The Science of the Total Environment, 69 (1988) 29-41.
- 2) De Felice P., Laitano R.F., Piermattei S., "Recent results (1986-1989) on the ENEA quality assurance programme for the radioactivity surveillance network in Italy", The Science of the Total Environment, in course of publication.

POST-CHERNOBYL FALLOUT IN ROMANIA

I. Osvath and C. Dovlete

Environmental Radioactivity Laboratory
Institute of Environmental Research and Engineering
Of. Postal 11, C.P. 11-2, Bucharest, Romania

As part of the Romanian environmental radioactivity monitoring programme, fallout samples have been systematically collected and analyzed for gamma emitters. Chernobyl fallout space-time patterns, radionuclide concentration ratios and deposition velocities have been determined. The resuspension process has been studied, environmental half-lives for ^{137}Cs and resuspension factors have been evaluated. Hot particles have been identified in some of the deposition samples.

INTRODUCTION - OUTLINE OF THE ROMANIAN ENVIRONMENTAL RADIOACTIVITY MONITORING PROGRAMME

In 1962, in response to the need for monitoring global fallout resulting from nuclear weapons tests, the National Environmental Radioactivity Surveillance Network (NERSN) was created in the frame of the existing Meteorological Network.

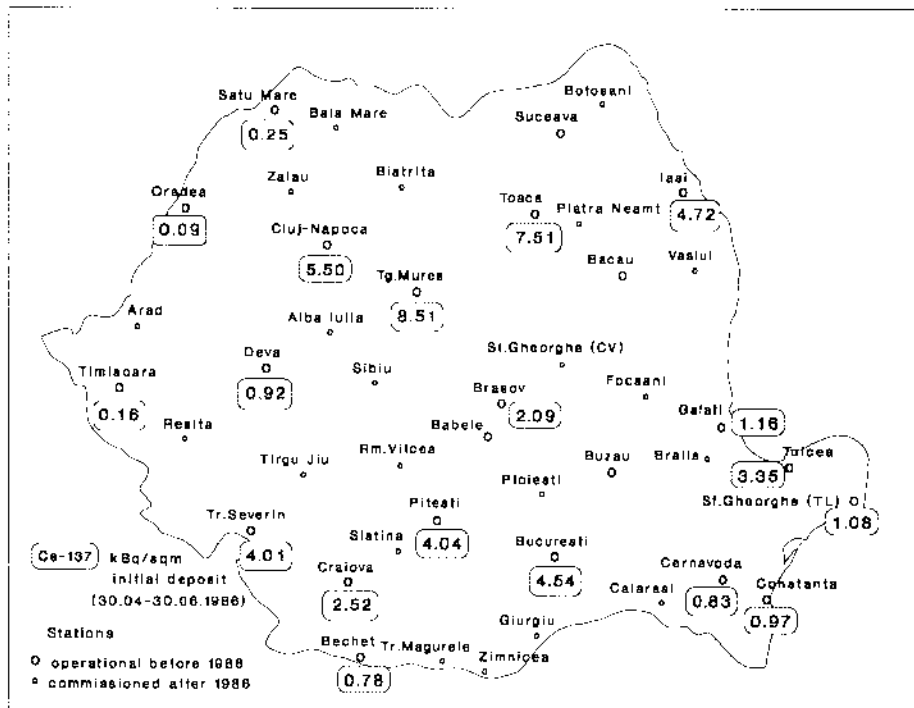

Fig.1. Stations of the Romanian National Radioactivity Surveillance Network. ^{137}Cs in fallout collected during 30.04-30.06.1986.

The NERSN has developed gradually, reaching a number of 23 stations in 1986. Following an increased interest of the public and of the counties' authorities for more detailed information regarding environmental radioactivity and radiological hazards associated with it, the number of stations has more than doubled in the years following the Chernobyl accident (Fig. 1) and activities at the Environmental Radioactivity Laboratory (ERL), which co-ordinates the Network, have been developed accordingly. Presently, the stations are affiliated to the counties' Agencies for Environmental Surveillance and Protection and report to ERL and the Ministry of Environment.

All stations follow a unitary methodology and programme in collecting and preparing samples, performing measurements and reporting data [1]. They sample atmospheric aerosol and deposition, soil, vegetation and surface, well and drinking water, perform gross beta measurements and forward the samples to the ERL for radionuclide analyses.

Among studies at ERL, those on fallout, hot particles and resuspension present a special interest due to the long-term radiological exposure pathways associated to them.

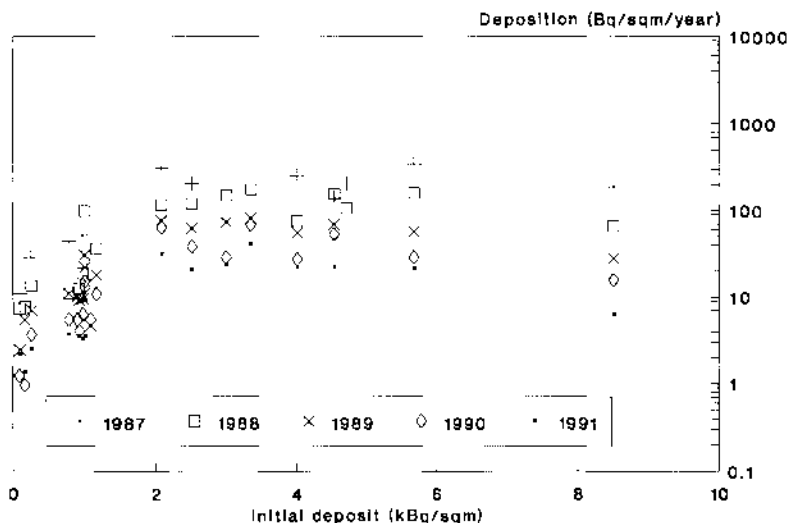

Fig.2. Annual ¹³⁷Cs deposition vs. ¹³⁷Cs in fallout collected during 30.04-30.06.1986, for several locations in Romania

METHODS OF SAMPLING AND MEASUREMENT

Fallout has been sampled employing 0.3 m² collectors. For most sites wet and dry deposition have been cumulated. For gamma spectrometrical analyses, monthly and annual samples have been prepared using samples collected daily. Exceptions were

made in 1986, when fallout has been cumulated over shorter periods in the first month after the Chernobyl accident, as well as with some individual daily samples showing relatively high activities, occurring in the following years. The latter have been successively divided and the resulting sub-samples analysed, some of them being thus demonstrated to contain hot particles.

Gamma spectrometrical analyses have been performed using high resolution, low background systems. All spectra have been analysed automatically. Complex spectra have also been evaluated using a semi-automated procedure which allows visual check and separate treatment for each peak or multiplet.

RESULTS AND DISCUSSION

The following radionuclides have been identified in fallout samples collected after the Chernobyl accident: ^{54}Mn , ^{95}Zr , ^{95}Nb , ^{99}Mo , ^{103}Ru , ^{106}Ru , $^{110\text{m}}\text{Ag}$, ^{125}Sb , $^{129\text{m}}\text{Te}$, ^{131}I , ^{132}Te , ^{132}I , ^{134}Cs , ^{136}Cs , ^{140}Ba , ^{140}La , ^{141}Ce , ^{144}Ce , ^{144}Ce , ^{147}Nd , ^{154}Eu , ^{155}Eu , ^{239}Np . Activity ratios and deposition velocities have been evaluated using specific activity data.

The levels of Chernobyl-derived fallout radioactivity, as resulting from samples collected at NERSN stations, were lowest in the North-Western part of the country, highest in the central, Eastern and Southern plains and at high altitudes (Fig. 1). Analyses of soil samples (in progress) show a more complicated pattern of contamination.

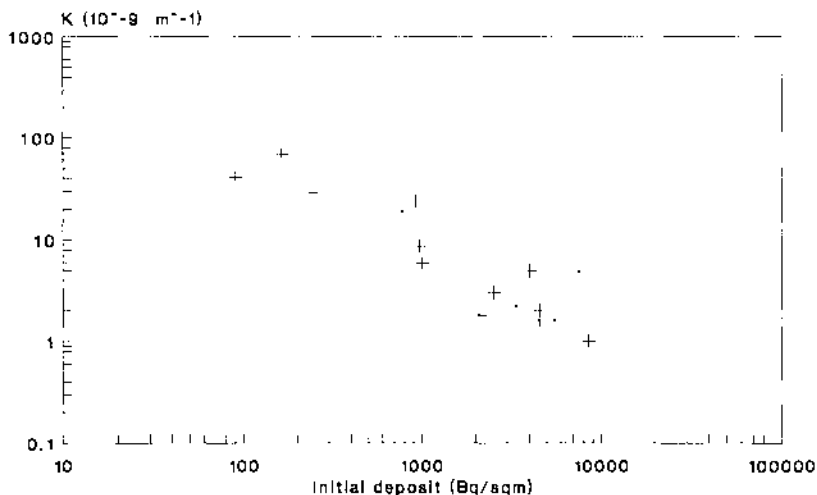

Fig. 3. Resuspension coefficient K vs. initial deposit of ^{137}Cs (30.04-30.06.1986) for several sites in Romania.

Measured monthly values of ^{137}Cs in atmospheric deposition show an exponential decrease with a site-dependent environmental half-life between 55-237 days during June 1986 - June 1987, and between 236-549 days during June 1986 - December 1991. Data on ^{137}Cs in yearly cumulated samples show that the magnitude of the initial deposit determines the magnitude of the subsequent deposition rate (i.e. sites with lower initial deposit associate lower deposition rates), but for values of the initial deposit above 2 kBq/sqm, the annual ^{137}Cs deposition does not vary with the initial deposit (Fig. 2). The resuspension coefficient K , defined in [2], decreases with increasing values of the initial deposit, as illustrated (Fig.3) by values computed for 1991, using yearly mean air concentration values [3]. K also decreases in time (Fig.4).

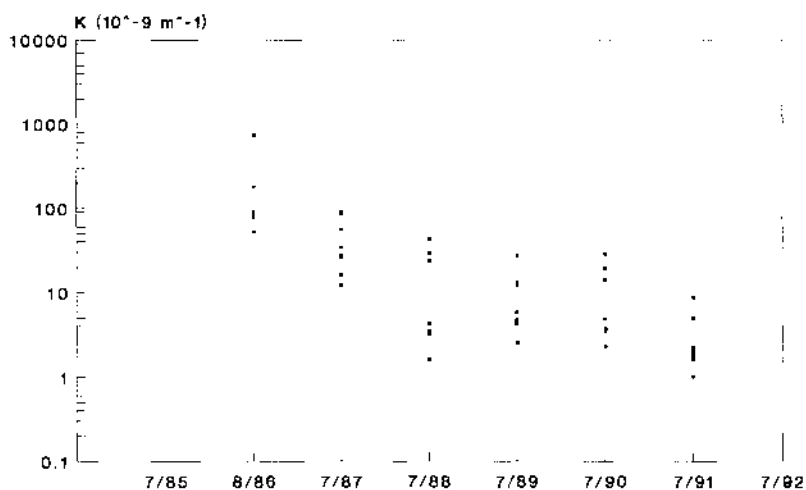

Fig. 4. Resuspension coefficient K , evaluated using ^{137}Cs data corresponding to several sites in Romania, vs. time.

During 1988-1990 several hot particles, with relatively high ^{144}Ce and ^{106}Ru activities, were identified in deposition samples, mostly originating from the Eastern part of Romania.

REFERENCES

1. *** - Procedures for environmental radioactivity measurements. Bucharest, 1987.
2. Nicholson K. W. - A review of particle resuspension. Atmospheric Environment 22, 2639-2651 (1988)
3. Sonoc S. - personal communication

RADON IN THE HUMAN ENVIRONMENT: A GLOBAL APPROACH

F. Steinhäusler
International Atomic Energy Agency,
P.O. Box 100, A-1400 Vienna, Austria

ABSTRACT

The largest IAEA/CEC Co-ordinated Research Programme "Radon in the Human Environment" is described in terms of programme objectives, quality assurance, standardization of surveys and preliminary results.

1. GLOBAL RECOGNITION OF THE RADON PROBLEM

Already in 1956 the importance of the non-occupational radon (Rn) exposure was pointed out (1). However, the international scientific and regulatory community had only just started to acknowledge the significance of the occupational exposure to radon decay products (Rn-d) in the case of the uranium underground miners (2). In the following 20 years mainly European and US-scientists provided a growing number of data (e.g. in the Proc. of the US-DOE Symposium Series "The Natural Radiation Environment"), which indicated the widespread occurrence of elevated Rn-d exposure in a variety of natural and technologically-enhanced natural radiation environments. Nevertheless it took until 1977 when the International Commission on Radiological Protection addressed radiation protection issues in uranium mines (3) and until 1981 for it to recommend an occupational Rn-d limit of 4.8 Working Level Months (4). In the 1980's the Organization for Economic Co-operation and Development, Nuclear Energy Agency (OECD-NEA), Paris (France) and the Commission of the European Communities (CEC), Brussels (Belgium) reviewed the state-of-the-art of Rn- and Rn-d metrology and dosimetric methods (5). In the United States of America the US-Department of Energy and the US-Environmental Protection Agency undertook the so far largest national Rn-programme (6). Within the framework of the United Nations the International Atomic Energy Agency (IAEA) responded to the request from 56 Member States and initiated, jointly with the CEC, a co-ordinated research programme on "Radon in the Human Environment". This international programme will co-ordinate the research efforts to quantify the impact of Rn on man.

2. THE IAEA RESPONSE

For the IAEA - Co-ordinated Research Programme (CRP) "Radon in the Human Environment" altogether 108 research project proposals have been approved, making it the largest CRP within the Agency; 25 CEC-approved projects are part of the CRP. This CRP encompasses scientists of largely differing experience in Rn-research, using a wide variety of equipment and analytical methods. Therefore it is imperative to ensure comparability of results obtained from the various studies. The IAEA organized the International Intercalibration and Intercomparison Programme (IIIP) for Rn- and Rn-d measurement techniques as part of a comprehensive Quality Assurance Programme (QAP). Another major objective is the standardization of the Rn survey techniques for the different applications, ranging from establishing a Rn-potential map or conducting an epidemiological survey concerning Rn-d induced lung cancer. Furthermore the CRP emphasizes an institutionalized exchange of information on the available methodology concerning inhalation dosimetry, risk assessment and mitigation techniques. Finally it is planned to establish an international Rn-databank for both members of the international scientific community and national regulatory agencies. The CRP is implemented in two phases. Phase I started in 1990 and consisted of the award of 37 Research Agreements, 12 Research Contracts and 4 Consultant Contracts to the following countries: Algeria, Argentina, Australia, Austria, Belgium, Brazil, Bulgaria, China, Costa Rica, Ecuador, Egypt, Germany, Ghana, Hungary, Iran, Ireland, Israel, Italy, Japan, Korea, Luxembourg, Malaysia, Netherlands, Norway, Pakistan, Poland, Singapore, Spain, Sudan, Sweden, Switzerland, Syria, Thailand, Tunisia, Turkey, United Kingdom, USA, Vietnam, Yugoslavia. The overall technical guidance of the QAP is provided by the members of the IAEA-IIIP: Environmental Measurements Laboratory (New York, USA); Bureau of Mines (Denver, USA); National Radiological Protection Board (Didcot, UK); Australian Radiation Laboratory (Melbourne, AUS). At the secondary level Regional Coordinators act as technical/logistical interface between the CRP-participants and the primary laboratories; for the American region: Instituto de Engenharia Nuclear (Rio de Janeiro, Brazil); for the European region: Centre of Radiation Hygiene (Prague, CSFR); for the Eastern European and Middle East region: Laboratory of Dosimetry and Radiation Protection (Sofia, Bulgaria); for the Asian-Pacific region: Ministry of Public Health, Laboratory of Industrial Hygiene (Beijing, China). In addition, the US-Environmental Protection Agency (EPA) and the IAEA are conducting jointly international intercomparison exercises and Rn-detector test programmes under defined laboratory exposure conditions. Standardized protocols were developed to assist in the co-ordinated conduct of Rn-surveys. In the pilot-phase of such a survey the technical and logistical components are tested, survey personnel are trained and the necessary regional/national programme infrastructure is established. The subsequently conducted large scale Rn-survey is conducted mostly with the objective of determining yearly averaged indoor Rn-values, using a standardized questionnaire for randomly selected individuals.

In 1991 the following QAP-related activities have been organized within the CRP:

a) an international field-intercomparison exercise (Rn in air and water; Rn-d in air) for active and passive devices in the high background area of the Rn-spa Badgastein (Austria); b) an international laboratory-intercomparison exercise (Rn in air) for integrating passive devices used by CRP-participants at the US-EPA Rn-chamber in Montgomery (Alabama); c) a climatic Rn-detector performance test (Rn in air) for commercially available integrating Rn-devices, simulating dry/humid hot/cold environments in the US-EPA Rn-chamber in Las Vegas (Nevada).

Results from pilot-surveys have indicated new data for population groups with elevated indoor radiation exposure levels in different regions of the world, for instance:

In China several hundred thousand inhabitants reside in carbon-brick dwellings, which contain elevated levels of ^{238}U (≤ 20.8 kBq/kg) and ^{226}Ra (≤ 30 kBq/kg). This causes an increased gamma dose rate up to 940 nGy/h (7). Also millions of Chinese live in underground earth-dug cave-dwellings, in some cases exposed to Rn-levels in excess of 650 Bq/m³.

In Europe the environmental impact of Bulgarian uranium mining and milling activities has been studied. Areas were identified with ^{226}Ra -levels in soil up to 10 kBq/kg and elevated Rn-levels indoors (≤ 400 Bq/m³) due to ^{226}Ra -surface contamination on the walls (8).

In Africa elevated Rn-levels have been found in Ghana and Sudan. In the former case Rn-concentration in traditional Ghana-houses (clay bricks, small windows) was found to be significantly in excess of US-EPA action levels due to poor ventilation (9); in the latter case increased $^{238}\text{U}/^{226}\text{Ra}$ -levels in the high background area of Lake Miri can cause elevated exposure of the local residents up to 38.6 mSv/year effective dose (10).

3. THE NEED FOR INTERNATIONAL CO-ORDINATION

With regard to research increased co-ordinating efforts are warranted in the areas: source term characterization (contribution from thoron daughters, transport phenomena); aerosol sciences (interactions of Rn-d with other pollutants and aerosols); micro- and biological dosimetry (dose reconstruction for different species); molecular radiobiology (in vitro cellular approach). Details are discussed in ref. 11. Co-ordination is also required in the implementation of the large number of Rn-programmes planned worldwide, concerning: data collection and -storage methods; QAP; Rn-mitigation techniques. Harmonization of the international regulatory approach to risk limitation from Rn-d inhalation is of particular interest. Several exposure situations have to be addressed, such as non-occupational exposure

(residential use of owner occupied buildings vs. rented accommodation), occupational non-mining exposure (Rn-spas, public buildings vs. schools, offices and general workplaces) and occupational mining exposure (uranium-, non-uranium-mining and milling).

REFERENCES

1. HULTQUIST, B., 1956, Studies on naturally occurring ionizing radiations, Kungl. Svenska Vetenskapsakademiens Handlingar, Fjärde Ser. Vol. 6, No. 3.
2. BALE, W.F., 1951, Hazards associated with radon and thoron, Memorandum, US-DOE Environmental Meas. Lab., New York, N.Y., Archives.
3. ICRP Publication 24, 1977, Radiation protection in uranium and other mines, Ann. ICRP 1(1).
4. ICRP Publication 32, 1981, Limits for inhalation of radon daughters by workers, Ann. ICRP 6 (1).
5. ILARI, O. and STEINHÄUSLER, F., 1983, The OECD/NEA programme on radon and thoron dosimetry and monitoring: its contribution to the assessment of public exposure to natural radiation. Rad. Prot. Dosim. 7, 175-179.
6. US-DOE/US-EPA, 1989, Federal radon activities inventory, 1988-1989, Doc. no. DOE/ER-0409
7. WANG, Z., REN, T., ZHANG, S., STEINHÄUSLER, F., HOFMANN, W., POHL-RÜLING, J., 1991, Elevated indoor exposure in Chinese carbon brick-and cave dwellings, Rad. Prot. Dosim. (in press).
8. UZUNOV, I., DIMITROV, M., STEINHÄUSLER, F., 1991, Environmental radiation levels and occupational exposure due to uranium mining and milling operations in Bulgaria, Rad. Prot. Dosim. (in press).
9. ANIAGYEI, H.M., 1991, personal communication.
10. MUKHTAR, O.M., ELKHANGI, F.A.R., 1991, Environmental study for radionuclides in Miri Lake area, Nuba mountains. Rad. Prot. Dosim. (in press).
11. STEINHÄUSLER, F., 1991, The need for a coordinated international assessment of the radon problem, Proc. Int. Symp. Radon and Radon Reduction Technology, Philadelphia (USA), Apr. 2-5 (in press).

RADON-INDUCED LUNG CANCER RISK AT ENVIRONMENTAL DOSE LEVELS

W. Hofmann

Division of Biophysics, University of Salzburg, Austria, and

D.J. Crawford-Brown

Department of Environmental Sciences and Engineering,
University of North Carolina, Chapel Hill, NC 27599-7400, USA

ABSTRACT

A non-linear lung cancer risk model has been developed, in which both the functional form of the dose-response relationship and its parameter values arise from radio-biological observations at the cellular and organ level. Depending on the effectiveness of ionizing radiation as either promoter and/or initiator, different dose-effect curves will be obtained in the low dose region, which are generally lower than the linear risk estimate.

INTRODUCTION

Because of the inevitable interaction of confounding factors, any estimate of lung cancer risk at low, environmental exposures to radon progeny must be based on some form of extrapolation from high radon levels. Current radiation protection regulations are based on the philosophy that the excess risk is linearly related to the cumulative exposure. Here, we contrast the linear hypothesis with theoretical predictions based on a non-linear cancer risk model. This model is based on radiobiological mechanisms at the cellular level. The intent is to provide a coherent understanding of in-vitro cellular transformation and in-vivo organ carcinogenesis. Such an approach requires a set of assumptions concerning cellular radiation effects of alpha particles relevant to radiation carcinogenesis. Predictions of the relative lung cancer risk are compared with epidemiological findings in U.S. uranium miners (1).

CELLULAR RADIATION EFFECTS

In line with radiobiological observations, our predictive model of lung cancer induction is based on three properties of radiation: (i) transformation of cells, (ii) inactivation of cells, and (iii) stimulated cellular division in a stem cell population. This model has been used to estimate the carcinogenic risk of beta-emitting hot particles in lung tissue (2). Here, an additional assumption has been incorporated, namely (iv) the need of a cell to be released from contact inhibition in order to express its full potential as a transformed cell (3).

In the present lung cancer induction model we assume five states in the development of a cell from the initial unirradiated

level (state 1) to a fully transformed one (state 5) (3). The intermediate steps are: production of a specific DNA damage (state 1 to 2), production of a less specific DNA damage (state 2 to 3), cellular division (state 3 to 4) and release from contact inhibition (state 4 to 5). Competing with these mechanisms at each transition is radiation-induced cell death. Lung cancer risk is then assumed to be proportional to the number of transformed cells.

According to the common terminology of "initiation" and "promotion" in carcinogenesis, movement from state 1 to 3 may be identified as the initiating event and the two subsequent transitions as promotion events. Radiation, like all carcinogens, has properties of both initiation and promotion.

LUNG CANCER RISK PREDICTIONS

Cumulative doses for a given exposure category are calculated assuming a median length of exposure of 4 years in all exposure categories (1) and a dose-exposure conversion factor of 3.9 mGy WLM^{-1} . Multiplication of the risk for a sensitive cell in bronchial epithelium, receiving a given cumulative dose, by the number of cells in a given generation (4) and summation over all bronchial generations (5) yields the carcinogenic risk for a defined exposure category.

First we assume that radiation acts both as initiator and promoter (IP-model). The in-vitro transformation frequency per viable cell for alpha particle irradiation (6,7) already represents the total probability of reaching the final stage of uninhibited growth, comprising all initiation and promotion steps. Two modifications have been made to obtain the transformation probability per exposed cell and to simulate in-vivo transformation under conditions of cellular replacement.

The relative lung cancer risk for the IP-model as a function of cumulative exposure is plotted in Fig. 1 together with the epidemiological data of Hornung and Meinhardt (1). Given the large statistical uncertainty of the epidemiological information, there is excellent agreement between predicted and observed lung cancer risks over the entire range of cumulative exposures. At low doses, our non-linear model predicts a slightly lower risk as has been observed in the epidemiological study. It should be noted, however, that such a sublinear shape with a rising slope is consistent with the lung cancer data reported by Samet et al. (8).

If we assume that cells have already been initiated by co-carcinogenic factors, such as cigarette smoke, then radiation can promote these initiated cells by stimulating cellular division and stopping contact inhibition (P-model). At the same time, however, it can also kill the cells. Lung cancer risk in the P-model is very similar to the predictions with the IP-model displayed in Fig. 1.

Based on the histopathological observations of smoke-induced hyperplasia of bronchial cells, we assume that the primary promotional role of cigarette smoke is through stimulation of cellular division (CSP-model). An increase in the efficiency of cigarette smoke promotion relative to that of radiological promotion produces a higher risk at low doses and a smaller risk at high doses when compared to pure radiological promotion. Thus the additional promotional effect of cigarette smoke yields an approximately linear dose-effect curve at low doses.

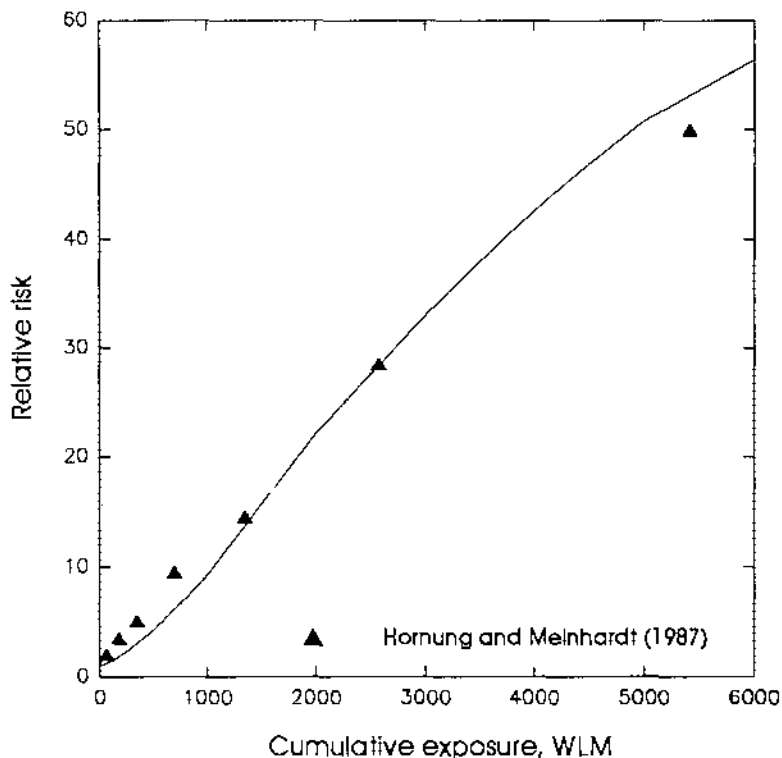

Fig. 1 Predictions of the relative lung cancer risk (radiation acts both as initiator and promoter) as a function of cumulative radon progeny exposure and comparison with epidemiological data.

CONCLUSIONS

If radiation is assumed to act as initiator and promoter (IP-model) or only as promoter (P-model), then the predicted lung cancer risk in the low dose regime is smaller than that based on the linear hypothesis. If radiation is effective primarily as an initiator (with cigarette smoke being the main promoter), then the

predicted incidence at low doses approaches the linear estimate.

While these models use mean doses, explicit incorporation of variability in cellular doses modifies the above risk predictions. Assuming lognormal cellular dose distributions, a larger variability increases the risk at high doses, but reduces the incidence at low doses (9). On the other hand, if enhanced deposition and reduced mucociliary clearance at bronchial bifurcations is factored into our risk analysis, then lung cancer risk is increased at low exposures relative to the current assumption of a uniform airway dose distribution used in the above models (10).

Considering the uncertainties of each modeling approach, a realistic combination of all factors discussed above suggests that the linear hypothesis represents a realistic upper boundary in the low doses region, thus being a viable compromise for radiation protection purposes.

REFERENCES

1. Hornung, R. and Meinhardt, T., 1987, Quantitative Risk Assessment of Lung Cancer in the U.S. Uranium Miners, *Health Phys.* 52, 417-430.
2. Hofmann, W., Crawford-Brown, D.J. and Martonen, T.B., 1988, The Radiological Significance of Beta Emitting Hot Particles Released from the Chernobyl Nuclear Power Plant, *Radiat. Prot. Dosim.*, 22, 149-157.
3. Crawford-Brown, D.J. and Hofmann, W., 1990, A Generalized State-Vector Model for Radiation Induced Cellular Transformation, *Int. J. Radiat. Biol.*, 57, 407-423.
4. Mercer, R.R., Russell, M.L. and Crapo, J.D., 1991, Radon Dosimetry Based on the Depth Distribution of Nuclei in Human and Rat Lungs, *Health Phys.*, 61, 117-130.
5. Yeh, H.C. and Schum, G.M., 1980, Models of Human Lung Airways and Their Application to Inhaled Particle Deposition, *Bull. Math. Biol.* 42, 461-480.
6. Hieber, L., Ponsel, G., Roos, H., Fenn, S., Fromke, E. and Kellerer, A.M., 1987, Absence of a Dose-Rate Effect in the Transformation of C3H 10T1/2 Cells by α -Particles, *Int. J. Radiat. Biol.*, 52, 859-869.
7. Thomassen, D.G., Seiler, F.A., Shyr, L.-J. and Griffith, W.C., 1990, Alpha-Particles Induce Preneoplastic Transformation of Rat Tracheal Epithelial Cells in Culture, *Int. J. Radiat. Biol.* 57, 395-405.
8. Samet, J.M., Pathak, D.R., Morgan, M.V., Marbury, M.C., Key, C.R. and Valdivia, A.A., 1989, Radon Progeny Exposure and Lung Cancer Risk in New Mexico U Miners: A Case-Control Study, *Health Phys.*, 56, 414-421.
9. Crawford-Brown, D.J. and Hofmann, W., 1989, The Role of Variability of Dose in Dose-Response Relationships for Alpha Emitting Radionuclides, *Radiat. Prot. Dosim.*, 28, 283-290.
10. Hofmann, W., Crawford-Brown, D.J., Menache, M.G. and Martonen, T.B., 1990, Carcinogenic Risk of Non-Uniform Alpha Particle Irradiation in the Lungs: Radon Progeny Effects at Bronchial Bifurcations, *Radiat. Prot. Dosim.*, in press.

**EXPOSURE TO COSMIC RADIATION:
A DEVELOPING MAJOR PROBLEM IN RADIATION PROTECTION**

**Wayne M. Lowder and Ferenc Hajnal,
USDOE Environmental Measurement Laboratory, New York, NY, USA
(possibly coauthors from NASA, FAA, and other agencies)**

Cosmic radiation at ground altitudes is usually a relatively minor contributor to human radiation exposure, producing a global collective dose equivalent that is about 10 percent of the total from all natural sources. However, more than a million people living at high altitudes receive annual dose equivalents in excess of 5 mSv. In recent years, there has been increasing concern about the exposure of aircraft flight crews and passengers, for whom annual dose equivalents of up to several mSv have been estimated. Recent EML results indicate the presence of an important high-energy neutron component at jet aircraft altitudes, perhaps producing dose equivalents of the order of 0.1 mSv/h at high latitudes. Finally, space agencies have been long concerned with the potential exposures of astronauts, especially from the rare massive solar flare events. As more people venture into space, this source of human radiation exposure will become increasingly important.

Available data on these aspects of cosmic radiation exposure will be reviewed, along with current and anticipated future research activities that may yield an improved assessment of the problem. The question of how such exposures might be controlled will be addressed, but not answered.

EXPOSURE TO RADON IN ABOVE GROUND WORKPLACES

THE EXPERIENCE IN GREAT BRITAIN (GB)

B C ROSS* AND D W DIXON*

* Technology Division, Health and Safety Executive (HSE)
Magdalen House, Stanley Precinct, Bootle, Merseyside L20 3QZ

+ National Radiological Protection Board (NRBP) Chilton, Didcot,
Oxfordshire

ABSTRACT

Regulations regarding exposure of employees and others to ionising radiation including exposure to radon were introduced in GB in 1985. Research by HSE over a number of years has identified the type and location of workplaces most affected by radon. Exposures in excess of the action levels in the regulations have been identified and appropriate action taken. Further research is underway to identify other affected areas and compare methods of measurement. Liaison has taken place between government departments to produce advisory material for employers and employees.

REGULATORY BACKGROUND

In Great Britain (GB) safety regulations for employees and others affected by their work are made under the Health and Safety at Work Act 1974. In 1986 the Ionising Radiations Regulations 1985 (IRR85)¹ were introduced. These regulations include requirements which are binding on GB by virtue of its Membership of the European Community. The requirements are contained in the Euratom Directives of 1980 and 1984 and are traceable to International Commission on Radiological Protection (ICRP) publications 26(1977) and 30(1979).

The requirements in IRR85 for radon are introduced under "work with ionising radiation". This is any work in which there is any exposure of a person to an atmosphere containing the short lived daughters of radon 222 at a concentration averaged over any 8 hour working period of greater than $6.24 \times 10^{-7} \text{ J m}^{-3}$ ie 0.03 Working Levels (WL). This corresponds to a dose of 5 mSv over a 2000 hour working year which is the supervised area level. Strictly exposure to 0.03 WL for 2000 hours corresponds to a dose of about 3.5 mSv, with a conversion factor of 10 mSv per WLM, and after allowance for exposure to natural sources other than radon 222. An important requirement of the regulations is the appointment of a radiation protection adviser at a concentration of 0.1 WL. Guidance on application of the regulations is given in an approved code of practice² which contains advice on for example restriction of exposure, personal dosimetry and area monitoring. Guidance has also been produced for HSE inspectors and environmental health officers. The latter inspect premises such as offices and shops. Inspectors have also been given training and are backed up by radiation specialists who have appropriate experience and radon monitoring equipment.

WORKPLACE STUDIES

In 1983 HSE commissioned a series of research programmes designed to obtain information on the type and location of premises where the IRR85 were likely to apply³. The first studies concentrated on Devon and Cornwall where it was known that high levels existed in some homes. NRPB undertook radon monitoring work for HSE using their track etch plastic detector, which is mounted in a housing which acts as a diffusion chamber and also acts as mechanical protection. Earliest measurements also included active sampling.

Monitors were sent by post individually to each employer with instructions for placement and return. Employers were asked to put the monitors in places that were routinely occupied. Account was also taken of the time of year in which the monitoring took place to allow for the annual variation that occurs in radon levels whereby levels are generally lower in summer than in winter. Since measurements of radon daughter concentrations can be laborious and time consuming, measurements with passive monitors over one month have been adopted in the UK as the routine method of screening to decide whether workplaces are likely to be affected by Regulations. Some care is needed in translating the results of radon gas measurements over one month to a radon daughter concentration during working hours, but for a typical diurnal variation, a screening value of 400 Bq m⁻³ measured with passive monitors over a month during winter provides an effective means of identifying workplaces where concentrations during the day might exceed 0.03 WL. Since these monitors are cheap, simple to use and can be sent through the post, they provide an effective means of screening large numbers of workplaces.

These initial studies showed that in premises such as workshops and production areas with good natural or forced ventilation it was unlikely that the action level of 0.03 WL would be exceeded. However places such as offices schools and hospitals may well exceed this level. Of the 50 workplaces studied 10 exceeded the supervised area level and 3 exceeded the controlled area level. The highest estimated annual dose was 24 mSv. The information was communicated to employers. Further research⁴ on the feasibility of simple methods of reducing radon daughter concentrations concluded that underfloor suction systems were likely to be very effective in many properties and that other methods were unlikely to achieve consistent and substantial reductions.

The latest studies undertaken by HSE surveyed a total of 670 premises in Cornwall, Devon, Derbyshire, Northamptonshire, Somerset and Scotland. The complete analysis is not available at the time of writing, but of the 145 results processed, 23 premises had levels in excess of the supervised area level. The highest radon gas concentration reported was 3000 Bq m⁻³ which gives an estimated 40 mSv dose for a 2000 hour exposure time. Although the premises with the highest concentrations were in Cornwall 20 premises in the other areas were identified as having concentrations likely to exceed the supervised area levels. Other studies have identified levels of several thousand Bq m⁻³ in a workplace in Derbyshire.

Further research has been commissioned with NRPB to obtain estimates of the distribution of radon gas concentration in workplaces throughout the country. This will be based primarily on correlation

with existing data for homes. Another area of current research is comparison of methods for monitoring exposure to radon. This work is designed to give further information on the accuracy and applicability of the methods for the purpose of complying with IRR85.

PROVISION OF INFORMATION

A recent development in GB in the approach to the radon problem is the consideration by government of exposures both at work and at home. This approach was advocated in the recent recommendations of the House of Commons Environment Committee⁵. It emphasised the need for a person to be given adequate information about the overall risk from exposure to radon. A leaflet is being prepared by the HSE which gives simple background facts about radon, gives guidance on action to be taken by employers and explains how to obtain assistance from the Department of the Environment for monitoring at home. In workplaces where it has been found necessary to take action to reduce radon levels employees are strongly recommended to have their homes tested as well. This is available free through the Department of Environment.

CONCLUSIONS

Research over the last 8 years has shown that workplaces with low natural ventilation in Cornwall and Devon are most likely to have the highest radon concentrations in GB. However other areas can have significant concentrations which require remedial action.

It is the experience in GB that a package of measures is necessary to achieve adequate protection from the risks posed by exposure to radon. This package should include research, regulations, production of guidance material, inspection and enforcement by the regulatory body.

It is likely that existing arrangements in GB will provide a good framework to cope with future developments in International Guidance and European Legislation for radon.

REFERENCES

1. The Ionising Radiations Regulations 1985 Statutory Instrument No 1333 Her Majesty's Stationery Office, London (1985).
2. Approved Code of Practice - Part 3 Exposure to Radon. Her Majesty's Stationery Office, London (1988).
3. Investigation of Radon Decay Product Exposures in Workplaces. HSE/NRPB CONTRACT 1/2037.1983. An Investigation of Radon Decay Products Exposures in Workplaces with low ventilation Rates. HSE/NRPB CONTRACT 1984.
4. An Investigation of the Feasibility of Simple Methods of Reducing Radon Daughter Concentrations in Workplaces HSE/NRPB CONTRACT 12560/12596 1989.
5. House of Commons Environment Committee 6th Report Indoor Pollution. Her Majesty's Stationery Office 12 June 1991.

NATURAL RADIATION INDOOR EXPOSURE OF ITALIAN POPULATION

F.Bochicchio ^(*), G.Campos Venuti ^(*), S.Manciozzi ^(*), S.Piermattei ^(*),
S.Risica ^(*), L.Tommasino ^(*), G.Torri ^(*).

^(*) Istituto Superiore di Sanità, Roma, Italy.

^(*) ENEA/DISP, Roma, Italy.

ABSTRACT

A natural radiation survey based on the choice of a statistically representative sample of 5000 dwellings began in Italy in 1989. The paper analyses the radon results obtained in 45% of the national sample. The arithmetic mean of the concentration is equal to 80 Bq/m³ and the number of dwellings exceeding 200 and 400 Bq/m³ is around 5% and 1% of the total, respectively. The concentration distribution could be described by a log-normal curve, but with a significant underestimation of the high concentration tail.

INTRODUCTION

The aim of the national survey was: i) to obtain the distribution of radon concentration and of absorbed dose rate in air; ii) to evaluate the average exposure of the population to natural radiation. These data might allow an assessment of the percentage of dwellings, which exceeds some reference levels of radon concentration, and the average risk - according to present knowledge - for the population due to radon indoors. The opportunity and the social and economical cost of regulatory choices could thus be evaluated.

The strategy chosen - a two stage stratified sampling according to administrative districts and population - is described in ref.1. The peculiarity of the survey is the involvement of several public laboratories in carrying out the measurements and local health authorities in approaching the families. The survey was designed to give representative data of radon concentration both at district and at national level, allowing also to proceed in different time steps.

The organization and the state of art of the survey, the experimental set up, the protocols and the questionnaires adopted, the acceptance of the public, have been presented elsewhere (ref. 2, 3). In this paper the quality control methodology and the experimental results in 45% of the sample are presented.

QUALITY ASSURANCE AND QUALITY CONTROL PROCEDURES

As the survey involves around twenty laboratories with different operational experience, a sound quality assurance/quality control programme has been set up. It foresees: the intercomparison among laboratories at the beginning of the measurement phase, the use of duplicate dosimeters (each containing two detectors), a strict protocol to assemble the detectors, to perform the measurements and to analyse the data. The QA/QC programme is

carried out by the two National Institutes in order to guarantee the comparability of the various data sets.

Regarding the quality assurance of the measurement apparatus, the dosimeters used in the survey were previously calibrated both at the NRPP radon chamber (twice) and at the USDOE-EML (once). The three calibration factors have a coefficient of variation of 5%. In the first two intercomparison runs organized in Italy at central level the coefficients of variation among the different laboratories were 8% and 11%.

The complete set of data from detector pairs (one detector for each dosimeter) were compared by means of parametric and non parametric tests (ref.4) to verify their consistency and to identify possible outliers. In these cases, the third detector is processed and, sometimes, even the fourth (used as back up detector by the National Institutes).

An evaluation of the errors affecting the measurements of the laboratories involved - connected with differences in batch, in etching procedure, in track counting, etc. - was performed. A first analysis allowed to assign a global uncertainty around 30% for radon concentrations up to 50 Bq/m³ and 20% for concentrations above the same value. A more detailed study is at present being carried out.

RESULTS

The survey is still in progress. Data from 45% of the national sample (northern and central districts) have been analysed. The distribution of annual radon concentration in dwellings (see fig.1) has approximately a log-normal shape. The Kolmogorov-Smirnov test was performed to assess the goodness-of-fit of the actual distribution with a log-normal curve. A negative result ($p < 10^{-6}$) was obtained.

The arithmetic mean of radon distribution in the different districts ranges from 43 to 117 Bq/m³ and the overall mean is 80 Bq/m³, with an estimated statistical uncertainty of 3 Bq/m³ (95% of confidence level). The median is equal to 61 Bq/m³, close to the geometric mean, which is equal to 62 Bq/m³, with a statistical uncertainty of 2 Bq/m³ (95% c.l.).

The fraction of dwellings with mean radon concentration exceeding 200 Bq/m³ and 400 Bq/m³ - the reference levels adopted by the European Community for new and existing dwellings - ranges in the different districts from 0.6% to 9.9% and from 0% to 4.9%, respectively. In the total measured sample this quantity is 5.1% and 1.3% respectively, with a statistical uncertainty of 1.0% and 0.6% (95% c.l.). The values obtained by the log-normal fit are 3.9% and 0.2%.

In conclusion, whereas the log-normal approximation gives a fairly good estimation of the distribution central value, it significantly underestimates the high radon concentration tail, as reported also by other authors (ref.5).

The mean ratio of the winter/summer concentrations ranges from 1.1 to 2.7 for different districts, with a mean value of 1.5. The correlation of radon concentration with floor level is shown in fig.2. The mean concentration decreases from basement to the ground and the first floor, becoming almost constant after the second floor.

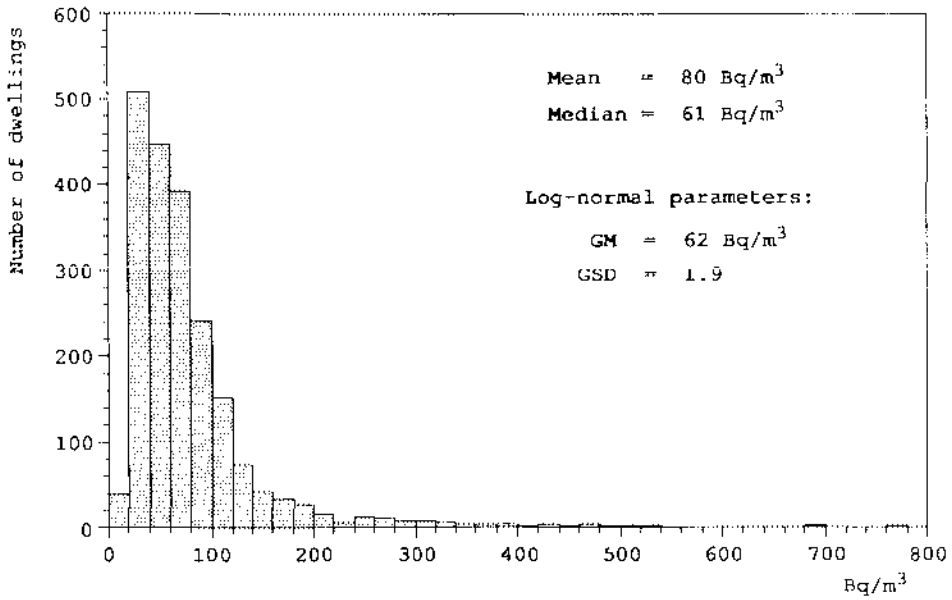

Fig.1 Distribution of annual radon concentration

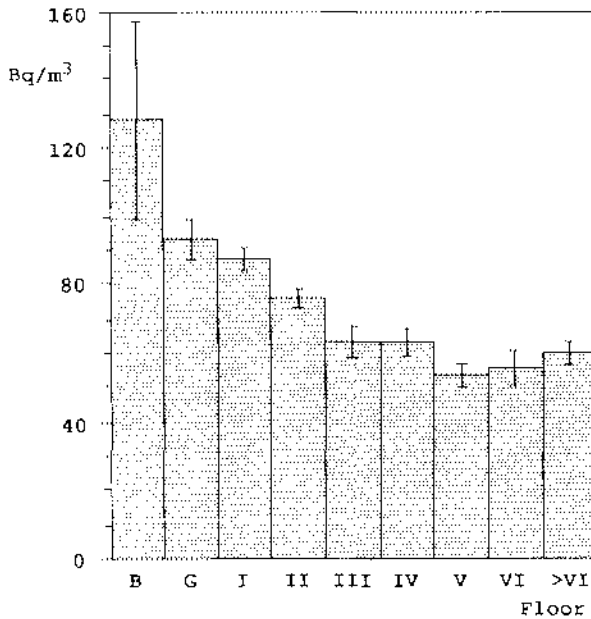

Fig.2 Mean annual radon concentration vs floor.
 The error bars represent one standard error.

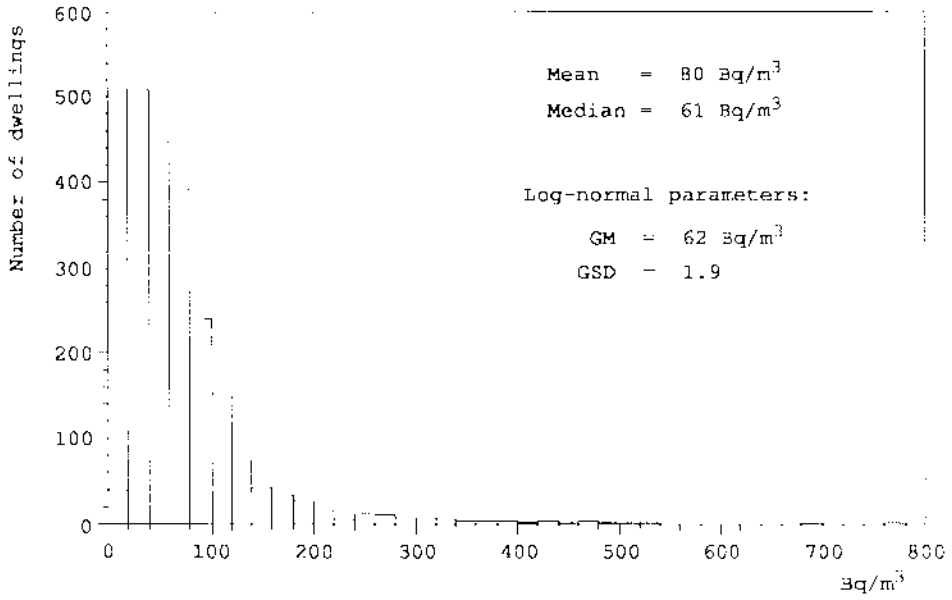

Fig.1 Distribution of annual radon concentration

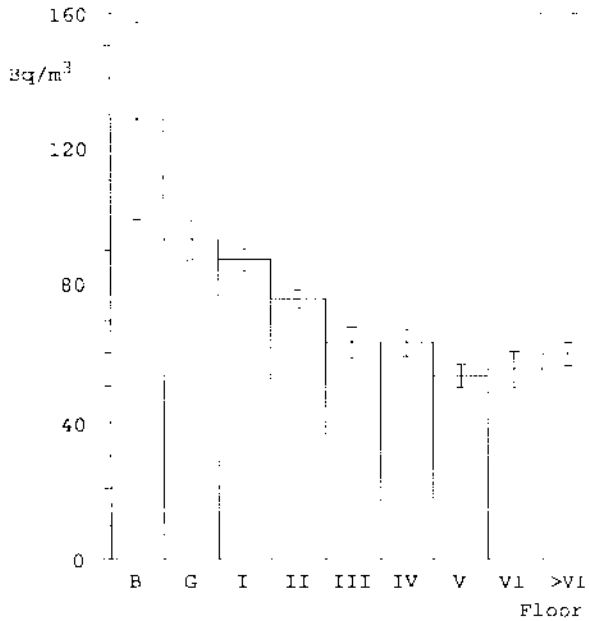

Fig.2 Mean annual radon concentration vs floor.
The error bars represent one standard error.

CONCLUSIONS

Taking into account the occupation factors indoors at home and elsewhere, obtained in the survey through questionnaires, the mean effective dose has been calculated (ref.6). The value ranges from 2.2 to 6.1 mSv/y in the different districts, with a mean of 4.1 mSv/y.

This evaluation confirms even in Italy the relevance of radon as a source of exposure to ionizing radiation.

REFERENCES

1. Campos Venuti G. and Piermattei, S., 1991, The importance of sampling strategy in the evaluation of exposure, *Radiat. Prot. Dosim.* 36, no.2/4, pp. 113-116.
2. Benassai, S., Bochicchio, F., Campos Venuti, G., Farchi, G., Mancicoppi, S., Marietti, S., Piermattei, S., Risica, S., Torri, G. and Tommasino, L., 1990, Design of a nationwide radiation survey, *Proceedings of the 5th International Conference on Indoor Air Quality and Climate*, Toronto, 29 July - 3 August 1990, vol. 3, pp.9-14.
3. Bochicchio, F., Campos Venuti, G., Piermattei, S., Risica, S., Tommasino, L. and Torri, G., 1991, Results of the representative survey on indoor radon in Northern Italy, *Proceedings of the Fifth International Symposium on the Natural Radiation Environment*, Salzburg September 22-28, 1991, in press on *Radiat. Prot. Dosim.*
4. Wilkinson, L., 1989, *SYSTAT: the system for statistics*, Evanston, IL:SYSTAT, Inc.
5. Goble, R. and Socolow, R., 1990, High radon houses: questions about log-normal distributions and implications for the epidemiology and risk assessment, *Proceedings of the 1990 International Symposium on Radon and Radon Reduction Technology*, 19-23 Feb. 1990, Atlanta (Georgia), Preprint 11.
6. Wrixon, A.D., Green, B.M.R., Lomas, P.R., Miles, J.C.H., Cliff, K.D., Francis, E.A., Driscoll, C.M.H., James, A.C. and O'Riordan, M.C., 1988, Natural radiation exposure in UK dwellings, *NRPB-R190*.

ACKNOWLEDGMENTS

The authors are very grateful to the personnel of the Laboratories for the environmental radioactivity control of: Friuli Venezia-Giulia, Emilia-Romagna, Lombardia, Umbria, Bolzano, Trento, Toscana and Piemonte for their collaboration.

Thanks are also expressed to M.Riccardi (ENEA/DISP) for his cooperation in the measurement programme, and to F.Felici and G.Moroni (Istituto Superiore di Sanità) for their assistance in the same programme.

The collaboration of Dr. R.Tommasi (ENEA/DISP) in the quality control tests has been much appreciated.

RADON IN THE OFFICE ENVIRONMENT

Dariush Azimi-Garakani

Radiation Hygiene Division, Paul Scherrer Institute,
CH-5232 Villigen PSI, Switzerland.

ABSTRACT

The results of weekly radon concentration measurements in an office environment using a novel envelope-type radon monitor for short term exposure periods are presented. The commercially available LR-115 damage track detectors are used and the chemically etched sheets are spark counted. The measurements were made over a period of one year. The indoor radon concentration varies from $\sim 20 \text{ Bq.m}^{-3}$ to $\sim 300 \text{ Bq.m}^{-3}$ with the average of 130, 81 and 73 Bq.m^{-3} for three different rooms resulting in the annual dose of 4.5, 2.8 and 2.5 mSv, respectively.

INTRODUCTION

Measurements of indoor radon concentrations have attracted much attention since early 1980. The correlation between lung cancer and exposure to radon has been well established [1], though the risk under normal indoor environmental conditions is somewhat uncertain [2]. There are a variety of radon detectors and dosimeters for indoor and outdoor radon measurements. The systems based on damage track detectors proved to be very attractive for their ability to integrate over long periods of time (months to years) [3]. Short-term exposure period as low as one week is needed when a screening survey is required [4]. This paper describes the results of weekly radon concentration measurements in an office environment using a gas radon sampling device for short-term exposure periods.

EXPERIMENTAL PROCEDURES

A novel envelope-type radon monitor has been designed and successfully used for short-term radon measurements [5, 6]. The commercially available LR-115 damage track detectors (9 cm x 12 cm) are used in this monitor. When the envelope is closed, the strippable LR-115 detector does not register alpha particles and the monitor is in the off state. When the envelope is opened, only half of the LR-115 sheet is exposed to the ambient. The second half of the foil, being protected by a plastic cover thick enough to stop all alpha particles, is used as "blank" detector. At the end of the exposure period, the LR-115 sheets are chemically etched in the 10% NaOH solution at 60 °C for 110 min and then spark counted [7, 8]. The radon concentrations were calculated using the calibration factor of $\epsilon = 2.03 \pm 0.07 \text{ cm}^{-2} \cdot \text{kBq}^{-1} \cdot \text{m}^3 \cdot \text{h}$ determined separately by the calibration exposure in the radon chamber.

RESULTS AND DISCUSSION

The weekly radon concentrations in an office situated in the lower ground level of a multi-storey building were measured using the envelope-type radon monitor. The office consists of three adjacent rooms with forced ventilation systems throughout the year. The measurements were made over a period of one year with no interruption.

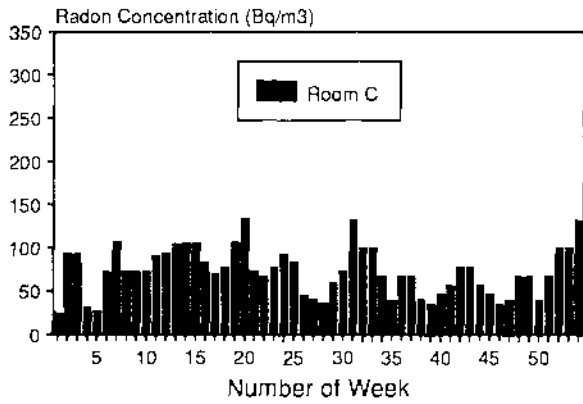
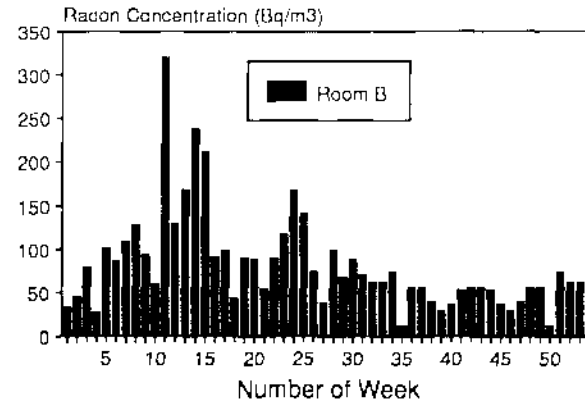
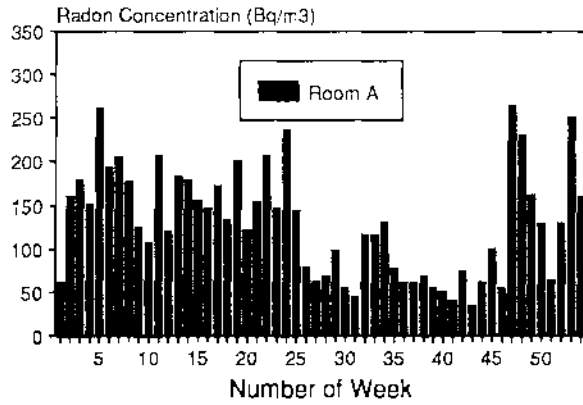

Fig. 1 Variation of weekly radon concentration in an office environment.

The variations of weekly radon concentrations for three different rooms are shown in Fig. 1. The results show that, in these rooms, the indoor radon concentration varies from $\sim 20 \text{ Bq.m}^{-3}$ to $\sim 300 \text{ Bq.m}^{-3}$. The average radon concentrations are 130, 81 and 73 Bq.m^{-3} for the Rooms A, B and C, respectively. The standard error of any single measurement did not exceed $\sim 10\%$ with the mean of $\sim \pm 4\%$. The annual dose resulting of radon concentration in the Rooms A, B and C are 4.5, 2.8 and 2.5 mSv, respectively, taking the concentration-to-dose conversion factor of $1 \text{ Bq.m}^{-3} = 0.035 \text{ mSv per year}$.

CONCLUSION

The envelope-type radon sampler in conjunction with spark counter proves to be the most convenient and simple method for short-term radon measurements as low as one week. These measurements are important for occupational health services. The weekly indoor radon measurements in an office over a period of one year showed that the concentration varies from $\sim 20 \text{ Bq.m}^{-3}$ to $\sim 300 \text{ Bq.m}^{-3}$ with the average of 130, 81 and 73 Bq.m^{-3} for three different rooms.

REFERENCES

1. Harley, N. H., Meyers, O. A. and Robins, E. S., 1991, Radon Daughter Dosimetry in the Dog Lung. Presented at the Fifth International Symposium on Natural Radiation Environment, Salzburg, Austria, September 22-28. To be published in *Radiat. Prot. Dosim.*
2. Lowder, W. M., 1989, Natural Environmental Radioactivity and Radon Gas. IN: *Proceedings of the International Workshop on Radon Monitoring in Radioprotection, Environmental Radioactivity and Earth Sciences*, L. Tommasino, G. Furlan, H. A. Khan and M. Monnin (Eds.), ICTP, Trieste, Italy, April 3-14, World Scientific Publishing, Singapore, 1-17 (1990).
3. Tommasino, L., 1988, Assessment of Natural and Man-Made Alpha Emitting Radionuclides. *Nucl. Tracks Radiat. Meas.* 15(1-4), 555-565.
4. Oppon, O. C., Azimi-Garakani, D., Tommasino, L., Torri, G. and Aziz, S., 1988, Radon Monitoring for Short Term Exposures in Indoor Air. *Nucl. Tracks Radiat. Meas.* 15(1-4), 633-636.
5. Tommasino, L. and Torri, G., 1990, Results of Short- and Long-Term Radon Measurements in Soil and Dwellings by Alpha Track Detectors. *The 1990 International Symposium on Radon and Radon Reduction Technology: Volume II. Preprints*. February 19-23, Atlanta, Georgia, USA. EPA/600/9-90/005b, US Environmental Protection Agency, January 1990.
6. Azimi-Garakani, D., 1991, Comparison of Different Passive Track Etch Detectors. Presented at the Fifth International Symposium on Natural Radiation Environment, Salzburg, Austria, September 22-28. To be published in *Radiat. Prot. Dosim.*

7. Cross, W. G. and Tommasino, L., 1970, A Rapid Reading Technique for Nuclear Particle Damage in Thin Foils. *Radiat. Effects* 5, 85-89.
8. Azimi-Garakani, D., 1989, Spark Counter for Alpha Particle Registration. IN: Proceedings of the International Workshop on Radon Monitoring in Radioprotection, Environmental Radioactivity and Earth Sciences, L. Tommasino, G. Furlan, H. A. Khan and M. Monnin (Eds.), ICTP, Trieste, Italy, April 3-14, World Scientific Publishing, Singapore, 164-170 (1990).

ETUDE EXPERIMENTALE DES EFFETS GENETIQUES DE LA
RADIOACTIVITE NATURELLE

M. Delpoux (1), H. Dulieu (2), A. Léonard (3)

Universités Paul Sabatier de Toulouse France (1), de Bourgogne
à Dijon, France (2), et de Louvain (Woluwé), Belgique (3)

EXPERIMENTAL STUDY OF THE GENETIC EFFECTS OF THE
NATURAL RADIOACTIVITY

The dose rates of natural telluric radioactivity usually range between 0.3 and 3.0 mGy/year ; however, they sometimes reach considerably higher values (more than 1 Gy/year). Apart from rare exceptions, the living organisms present on or in such soils are apparently normal. Yet, laboratory studies on their progenies suggest that natural telluric radiations have genetic effects. This has been verified by means of plant and animal genetic markers. The former have also shown that other environmental factors may in the long run play some role in the evolutionary process.

INTRODUCTION

Peu de travaux ont été consacrés à l'étude des effets biologiques de la radioactivité naturelle. La synthèse présentée ici, concerne les principes de quelques expérimentations et les résultats les plus importants obtenus ces vingt cinq dernières années par un groupe de recherche pluridisciplinaire.

MATERIELS ET METHODES

Trois types de travaux ont été réalisés :

I - observation de végétaux inféodés à plusieurs sites uranifères présents dans le sud de la France et comparaison avec les mêmes espèces présentes sur des substrats voisins ne contenant pas d'uranium et ses descendants radioactifs.

II - récolte de graines sur des espèces végétales présentes à la fois sur des substrats uranifères et non uranifères, les deux types de semences étant semées, pour comparaison, dans les mêmes conditions de microclimat, de substrat et d'environnement faiblement radioactif (bruit de fond naturel).

III - utilisation de marqueurs génétiques cultivés ou élevés au-dessus de certains de ces sites uranifères et sur des sites témoins voisins afin de détecter et d'évaluer les éventuels effets génétiques soupçonnés grâce aux travaux précédemment réalisés *in situ*. Les principaux marqueurs utilisés sont :

- le système $a1+/a1$ $a2+/a2$ du Tabac : il est constitué par deux gènes indépendants $a1$ et $a2$ conditionnant la différenciation des chloroplastes dans la variété *xanthi* n.c. de *Nicotiana tabacum* L. A l'état hétérozygote ($a1+/a1$ $a2+/a2$), cette combinaison génétique qui donne une couleur vert jaune aux feuilles par suite d'une déficience chlorophyllienne partielle, permet de déceler facilement les variations somatiques liées à ses modifications. Les plus fréquentes correspondent à des réversions de $a1$ vers $a1+$ ou de $a2$ vers $a2+$ qui s'expriment sous la forme de taches vert foncé sur le fond vert jaune des limbes. Le taux de réversion moyen (ρ) par génération cellulaire, s'obtient par un calcul simple à partir de données faciles à mesurer : surface des

feuilles (S), surface totale des secteurs mutés sur les feuilles étudiées (Sg), densité cellulaire (d) :

$$p = 1 - \left[\frac{S-Sg}{S} \right]^{1/t} \quad \text{où } t = \frac{\log Sd}{\log 2} - 7 \quad \text{et } N = Sxd,$$

t étant le nombre de générations cellulaires nécessaires pour former le tissu foliaire étudié.

des petits mammifères : lapins venant d'un élevage régional et souris de la race BALB/c. Ils ont été élevés dans des dispositifs construits au-dessus du site radioactif de Riviéral dans le Bassin permien de Lodève (France), des animaux témoins étant maintenus au voisinage, dans des dispositifs similaires placés au-dessus de sites caractérisés par le seul bruit de fond naturel. Chez les lapins, l'étude a concerné les chromosomes des lymphocytes. Chez les souris, c'est la fertilité des individus mâles et femelles qui a été prise en compte.

Dans tous les cas, les marqueurs génétiques sont cultivés ou élevés de manière à n'être soumis qu'à l'action des rayonnements ionisants émis par les sites uranifères.

RESULTATS

I - Observation des végétaux inféodés aux sites uranifères :

- sauf exception, les formations végétales et les végétaux présents sur ces terrains ont des caractéristiques déterminées par le climat de la région, le sol, l'action humaine et la concurrence biologique entre espèces en mélange ou en compétition sur les sites radioactifs. Ces ensembles biologiques ne sont pas "marqués" par les irradiations chroniques subies.

- une seule fois au printemps 1977 et sur le seul site uranifère du Mas d'Alary dans le Bassin de Lodève un cas d'albinisme a été observé sur *Galactites tomentosa* L. composée produisant normalement des capitules à fleurs violettes. Parmi les individus porteurs de telles inflorescences, il en a été distingué qui ne portaient que des capitules à fleurs blanches et d'autres portant à la fois des capitules à fleurs violettes et des capitules à fleurs blanches.

Cette dernière catégorie montre que les potentialités en ce qui concerne la couleur des fleurs a changé au cours de développement des plants. Le fondement génétique de ce changement a été démontré en étudiant la descendance, hors site uranifère, des trois catégories d'individus.

- on peut affirmer que en dehors de cette exception, certes spectaculaire, la présence de radionucléides en quantités anormalement élevées dans les substrats des sites uranifères et l'augmentation concomitante de l'irradiation tellurique ne modifient pas en apparence, les caractéristiques des populations vivantes fixées sur ces sites.

II - Etude de la descendance des végétaux inféodés aux sites uranifères

Des graines appartenant à différentes espèces (*Aegilops ovata* L., *Leucanthemum vulgare* L., *Nigella damascena* L., etc.) récoltées sur différents sites uranifères et sur des sites voisins non uranifères ont parfois permis de détecter dans les descendance observées des différences significatives (taux de germination,

taille des plantules et des plants adultes, etc.), transmissibles à travers les générations.

Ce fait s'ajoutant au cas d'albinisme observé *in situ*, a suggéré l'idée de la possibilité de modifications génétiques dans les espèces vivantes présentes sur les sites uranifères. Peuvent-elles être attribuées à l'action des rayonnements ionisants émis par l'uranium et ses descendants radioactifs ? Seule une expérimentation impliquant des marqueurs génétiques bien connus, soumis aux seuls rayonnements émis par les sites uranifères a permis d'apporter une réponse.

III - Modifications de marqueurs génétiques importés :

- système $a1/a1$ $a2/a2$ du Tabac :

Plusieurs essais ont été réalisés sur des sites uranifères du Bassin de Lodève et du Lauragais : la fréquence des variations somatiques observées sur les feuilles formées au-dessus des terrains uranifères a, parfois très nettement, augmenté. Le calcul des taux de réversion par génération cellulaire a montré que :

- il existe un seuil de débit de dose entre 3 à 4 cGy/an au-dessous duquel la radioactivité naturelle ne modifie pas le système marqueur ;

- au-dessus de cette valeur, et jusqu'aux valeurs les plus élevées mesurées sur les sites uranifères choisis pour l'expérimentation (environ 0.5 Gy/an), la relation dose-effet génétique est linéaire.

- aberrations chromosomiques chez le lapin :

Alors que les lymphocytes témoins n'en n'ont jamais montré, ceux étudiés chez les lapins maintenus au-dessus du site radioactif de Riviéral dans le Bassin de Lodève étaient caractérisés, après un an de séjour (doses reçues suivant les animaux de 0.2 à 0.7 Gy), par la présence de chromosomes dicentriques. L'expérience s'est poursuivie pendant trois ans. Après deux ans d'irradiation chronique, la fréquence des chromosomes dicentriques a peu à peu diminué pour devenir nulle au cours de la troisième année.

- fertilité chez la souris :

En sept mois, les animaux témoins et irradiés ont reçu respectivement 1.275 mGy, 0.45 et 0.63 Gy. Alors qu'une dose de 0.45 Gy a accru la fécondité des mâles et diminué celle des femelles, comme ceci avait été déjà observé dans une expérience préliminaire d'une durée de quatre mois sur des animaux ayant reçu des doses de 0.13 et 0.15 Gy. La fertilité des animaux ayant reçu une dose de 0.63 Gy a diminué dans les deux sexes.

L'ensemble des résultats obtenus démontre la réalité des effets de l'irradiation tellurique et en même temps, la complexité des faits observés.

CONCLUSION

Ponctuellement, l'irradiation naturelle tellurique provoque des changements dans les marqueurs expérimentés dont l'utilisation permet de détecter et d'évaluer des effets discrets et même la plupart du temps cachés ou inexprimés dans les populations naturelles pour différentes raisons, notamment :

- masquage par ceux liés à d'autres facteurs écologiques agissant simultanément ;

- faibles valeurs dans la nature des taux de germination et de reproduction ;
- généalogies impossibles à reconstituer sur le terrain ;
- masquage dans les espèces spontanées d'éventuels effets génétiques par les structures au moins diploïdes des espèces supérieures constituant l'essentiel de la biomasse actuelle;
- disparition des individus porteurs d'éventuelles anomalies sévères, en particulier de ceux porteurs de mutations létales.

Des études complémentaires, ont montré que d'autres facteurs de l'environnement : pollution atmosphérique, composition chimique des substrats, etc., déterminent des changements comparables à ceux observés au-dessus des terrains fortement radioactifs. La radioactivité naturelle, là où elle est anormalement élevée, et d'autres composantes de l'environnement peuvent de ce fait être considérées comme des facteurs de novation génétique susceptibles de jouer un rôle dans les processus de la différenciation biologique et au delà de la spéciation.

BIBLIOGRAPHIE

1. Delpoux, M., 1974, Etude expérimentale des effets de l'irradiation naturelle tellurique. Hypothèses sur l'influence de l'environnement fortement énergétique sur les êtres vivants, Thèse Univ., Toulouse.
2. Léonard A., Delpoux, M., Decat G. and Léonard E.D. 1978, Natural Radioactivity in South-West France and its possible Consequences for Mammals, Radiation Research, 77, 170-181.
3. Dulieu, H.L., and M.A. Dalebroux, 1975), Spontaneous and induced reversion rates in a double heterozygous mutant of *Nicotiana tabacum* var. *xanthi* n.c. dose-reponse relationship, Mutation Research, 30, 63-70.
4. Delpoux M., and Dalebroux M.A., 1981, Genetic Effects on the $a1+/a1$ $a2+/a2$ System of Tobacco over a Uranous Site in the Permian Basin of Lodève (Hérault, France), Mutation Research, 82, 101-110.
5. Delpoux M., and Dalebroux M.A., 1981, Genetic Effects on the $a1+/a1$ $a2+/a2$ System of Tobacco over a Uranous Site in Lauragais (Aude, France), Mutation Research, 82, 375-382.
6. Léonard A., Delpoux M., Chameaud J. Decat G., and Léonard E.D., 1981, Biological Effects observed in Mammals maintained in an area of very high natural radioactivity, Canad.J. Gen.Cytol.23, 321-326.
7. Léonard A., Meyer R., Delpoux M., Léonard E.D. and Decat G., 1983, Influence d'une radioactivité naturelle élevée sur la fécondité des souris mâles, C.R. Soc. de Biologie, France, 2, 234-238.
8. Delpoux M., Dalebroux M.A., Dulieu H., Léonard A., 1986, L'irradiation naturelle tellurique et les êtres vivants, Bull. Soc. Ecophysiologie, 11, 2, 157-184.

REMERCIEMENTS : travaux financés par la C.C.E (Contrat BF-16-F-122F, sous- contrat no.SC-001F)

TEMPORAL VARIATIONS OF INDOOR RADON CONCENTRATIONS

B. Majborn

Risø National Laboratory
DK-4000 Roskilde, Denmark

ABSTRACT

The results of a number of studies of temporal variations of indoor radon concentrations are presented and discussed. The studies include short-term temporal variations, seasonal variations and variations from year to year. The most noticeable results are that 1) for groups of Danish single-family houses the seasonal variation patterns were found to depend on the type of house substructure, and 2) the ratios of the seasonal to annual average radon concentrations were found to be less variable for the spring and autumn than for the summer and winter periods.

INTRODUCTION

Indoor radon concentrations may vary substantially with time on various temporal scales. The variations may depend on a number of factors, including meteorological and geological factors, house characteristics, and habits of the house occupants. Knowledge of temporal variations of indoor radon concentrations is important for a proper appraisal of the significance of monitoring results, and the identification of causes of such variations can contribute to improve our understanding of the mechanisms of radon entry into houses. During the period 1983-91 we have performed a number of investigations of radon in Danish dwellings, including studies of short-term temporal variations, seasonal variations, and variations from year to year. In this paper the main results of the various investigations are presented and discussed.

STUDIES OF TEMPORAL VARIATIONS

Temporal variations of indoor radon concentrations have been studied in different groups of houses:

- 1) In a pilot investigation of radon in Danish dwellings, integrating radon measurements were carried out in 70 single-family houses and 12 apartments for 3 months in winter and 3 months in summer (1983-84) (1).
- 2) Short-term and seasonal variations of indoor radon concentrations were studied in an investigation of influencing factors carried out in 1986-87 (2). The seasonal variation patterns were followed on a 2-month basis throughout the 2 years in 16 houses. Continuous radon measurements were carried out in an unoccupied house on an hourly basis for 2.5 months (spring 1986) and in five occupied houses on a 3-hourly basis for 2.5 months (spring 1987).
- 3) In 10 of the 16 houses mentioned above, the seasonal variation patterns were followed for an additional year, i.e.

integrating radon measurements were made in the 10 houses on a 2-month basis throughout 3 years (1986-88) (3). 4) Integrating radon measurements were made in 70 single-family houses on a quarterly basis throughout 1 year (1990-91) (4). The houses were selected according to type of sub-structure and type of soil underneath the house.

RESULTS AND DISCUSSION

The studies of short-term temporal variations of indoor radon concentrations reported in reference (2) were carried out in slab-on-grade houses. They predominantly showed a diurnal variation pattern with a maximum in the morning and a minimum in the late afternoon or early evening, indicating that pressure-difference driven flow of soil gas into the houses was the dominant mechanism of radon entry (5). This was in accordance with the seasonal variation patterns observed in the same houses which showed maxima in winter and minima in summer.

Figure 1 shows the seasonal variations of the geometric mean radon concentration for a group of 7 slab-on-grade houses during 3 years (3). In each house radon was measured in a

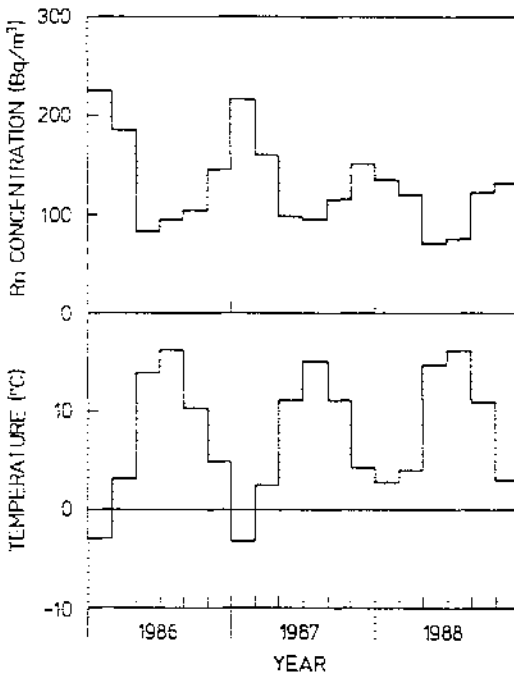

Figure 1. Seasonal variations during 1986, 1987 and 1988 of 1) the geometric mean value of the radon concentrations in 7 houses, and 2) the average outdoor temperature.

living-room and a bedroom on a 2-month basis. The figure also shows the average outdoor temperature (2-month averages) at a nearby meteorological station. As the variations of the average indoor temperature are small compared with those of the outdoor temperature, the results indicate a strong correlation on a 2-month basis between the average indoor-outdoor temperature difference and the geometric mean radon concentration for this group of houses. A major difference between the 3 years was an unusually cold January-February in 1986 and 1987 and an unusually mild January-February in 1988. This difference is clearly reflected in the observed radon concentrations. For the 7 living-rooms the geometric mean values of the annual average radon concentrations were 164, 160 and 125 Bq m⁻³ for 1986, 1987 and 1988, respectively. For the 7 bedrooms the corresponding geometric mean values were 132, 130 and 104 Bq m⁻³. Hence, the higher average outdoor temperature in 1988 is reflected in lower annual average radon concentrations, the geometric mean values for 1988 being 76-80 % of the corresponding values for 1986 and 1987. For the individual houses the largest year-to-year variation amounted to a factor of about 2, the annual average radon concentration in 1988 being 48 % of that in 1986.

In our studies of seasonal variations carried out during the period 1983-88, we found that mean winter/summer ratios of indoor radon concentrations in Danish single-family houses tend to show a dependence on the house substructure (3). Houses with slab-on-grade foundations had the highest mean winter/summer ratios, houses with a basement had intermediate ratios, and houses with a crawl space had the lowest ratios. A possible dependence of the seasonal variation pattern on the type of house substructure was further investigated in a new study carried out in 1990-91 (4). 70 houses were included. They were selected according to the type of substructure and the type of soil underneath the house. Five categories of substructure were included: Slab-on-grade, crawl space, basement, and combinations of basement with slab-on-grade or crawl space. In each house radon was measured in a living-room and a bedroom, in the basement if present, and in the crawl-space if present and accessible. The measurements were made with track detectors on a quarterly basis throughout a year. The study showed that the seasonal variation patterns of the geometric mean radon concentrations did depend on the type of house substructure. For living-rooms and bedrooms the seasonal variations ranged from being highly significant for the slab-on-grade houses to being insignificant for the crawl-space houses. For basements and crawl spaces the geometric mean radon concentrations did not show significant seasonal variations. A noticeable observation was that the ratios of the seasonal to annual average radon concentrations were less variable for the spring and autumn than for the summer and winter periods. This indicates that spring and autumn are the best seasons for carrying out screening measurements (say, of a few months duration) of radon in dwellings.

CONCLUSIONS

The main conclusions of our studies of temporal variations of indoor radon concentrations can be summarized as follows:

- 1) For a group of single-family houses with slab-on-grade foundations a strong correlation was indicated between the geometric mean radon concentration and the average indoor-outdoor temperature difference on a 2-month basis.
- 2) Year-to-year variations of indoor radon concentrations were observed, owing to a significant difference in average winter temperatures.
- 3) The seasonal variation patterns of the geometric mean radon concentrations for groups of Danish single-family houses were found to depend on the type of house substructure. For living-rooms and bedrooms the seasonal variations ranged from being highly significant for slab-on-grade houses to being insignificant for crawl-space houses. For basements and crawl spaces the geometric mean radon concentrations did not show significant seasonal variations.
- 4) The ratios of the seasonal to annual average radon concentrations were found to be less variable for the spring and autumn than for the summer and winter periods, implying that spring and autumn appear to be the best periods for carrying out screening measurements.

REFERENCES

1. Sørensen, A., Bøtter-Jensen, L., Majborn, B. and Nielsen, S.P., 1985, A Pilot Investigation of Natural Radiation in Danish Houses, Risø-M-2483.
2. Majborn, B., Sørensen, A., Nielsen, S.P. and Bøtter-Jensen, L., 1988, An Investigation of Factors Influencing Indoor Radon Concentrations, Risø-M-2689.
3. Majborn, B., 1990, Seasonal Variations of Indoor Radon Concentrations, In: The 1990 International Symposium on Radon and Radon Reduction Technology, Vol. III, Preprints, Paper C-V-3, United States Environmental Protection Agency, EPA/600/9-90/005c.
4. Majborn, B., 1991, Seasonal Variations of Radon Concentrations in Single-Family Houses with Different Substructures, Fifth International Symposium on the Natural Radiation Environment, Salzburg, 22-28 September 1991. (Submitted to Radiat. Prot. Dosim.).
5. Arvela, H. and Wingvist, K., 1986, Influence of Source Type and Air Exchange on Variations of Indoor Radon Concentration, Finnish Centre for Radiation and Nuclear Safety, STUK-A51.

RADON EXHALATION RATES FROM BUILDING MATERIALS AND FLY ASH-CONTAINING CONCRETES

A. Battaglia*, D. Capra*, G. Queirazza*, A. Sampaolo#

* Cise SpA - 39, Via Reggio Emilia - 20090 Segrate (MI) - ITALY

+ ENEL/CRTN - 54, Via Rubattino - 20134 Milano - ITALY

ENEL/CRC - 21 B/C, Via Dalmazia - 72100 Brindisi - ITALY

ABSTRACT

Natural radioactivity and radon exhalation rates on a large number of Italian building materials are presented and compared with identical measurements on coal ashes. The influence of fly ashes on concrete exhalation rates was investigated by performing accurate radon emanation measurements on slabs with different ash-to-cement ratios.

INTRODUCTION

High indoor radon concentrations are usually considered important sources of radiological hazard for the general public. For this reason an experimental program has been implemented to investigate the following parameters:

- a) the naturally occurring radionuclide content in different building materials selected according to the manufacturer's location and capacity, and in a large number of ash samples taken from Italian power plants;
- b) the radon emanation characteristics of above materials;
- c) the effect, on radon emanation, of ashes used as a partial substitute for cement in concrete.

MATERIALS AND METHODS

Naturally occurring radionuclide analysis

Germanium-detector gamma-ray spectrometry was used to determine ^{226}Ra , ^{228}Ra and ^{40}K concentrations (see Table 1).

Exhalation rate and emanating power

Exhalation rate and emanating power were measured in:

- a) powder samples (cements, hydrated limes, sands) analyzed without grinding;
- b) bricks and concretes analyzed both in their original form and ground (particle size between 4 and 10 mm);
- c) 20x20x10 cm concrete slabs made by mixing products individually characterized as described above.

Powder and ground samples were placed in containers which are small (11 cm dia. and 8 cm high) compared with radon diffusion length for this kind of material; it may therefore be assumed that radon will not decay significantly in the sample⁽¹⁾.

The radioactive gas emanation was assayed by evaluating the initial radon growth slope⁽²⁾ through the continuous monitoring of the gas concentration in a box sized to ensure easily measurable radon activity levels by keeping gas back-diffusion within acceptable limits. CISE-designed flask monitors⁽³⁾ ensuring an efficiency of 0.27 cpm/(Bq/m³) and a background of 1.2 cpm were used.

Analytical results (mean and standard deviation), are summarized in Table 2 for different kind of material.

Radon emanation from concrete and moisture content

The influence of free water content on radon emanation from 20x20x10 cm concrete samples was studied by measuring radon exhalation rates from concrete slabs saturated with water and then sequentially dried in oven.

Radon emanation from concrete with fly ashes

The effect of cement hydration on emanation properties was investigated measuring radon exhalation rates from 20x20x10 cm concrete slabs made with low-radium inert materials (white limestone) and different types of cement. In Table 3 are listed the radiological characteristics of the used materials.

The effect of fly ashes on concrete radon emanation was investigated on 20x20x10 cm slabs in which cement was replaced with South African and American fly ash in a proportion ranging from 5% to 40%. Results are reported in Table 4 (columns 2 and 3). In columns 8 and 9 are presented fly ash emanating power values computed on the assumption that a) cement has an average emanating power of 56.8%, calculated from the results of previous tests (see Table 3), and b) the inert material exhalation rate remains unchanged.

RESULTS AND DISCUSSION

Naturally occurring radionuclides and exhalation rates

Tables 1 and 2 show a marked variability in natural radionuclides concentrations and in exhalation rates for all groups of materials. Insofar as average values are concerned, coal ashes have ²²⁶Ra levels comparable with those found in volcanic materials, while exhalation rates are half-way between those of portland-pozzolanic cements and the other tested materials. Coal ashes have very low emanating power values, comparable with those of bricks.

Radon emanation from concrete and moisture content

Results show that the radon exhalation rate varies, with a good linear correlation, from 0.2 to 4 $\mu\text{Bq kg}^{-1} \text{ s}^{-1}$ when moisture content rises from 0% to 5%. This phenomenon may be due to the radon atoms adsorption on the pore surface within the concrete⁽⁴⁾⁽⁵⁾. The presence of water favours radon atoms migration outside the concrete. When there is no water inside the pores, radon atoms can adsorb on the pore surface; when water fills the pores, an increasing amount of radon can move out.

Radon emanation from concrete with fly ashes

Results summarized in Table 4 (columns 2 and 3) show that the addition of fly ashes causes a slight increase in radon emanation. Increase is smaller for American fly ashes than for South African ones.

Table 3 (column 4) and Table 4 (columns 6 and 7) show that concrete emanating power values are in the range 15-30%. These values are higher than those of cements, inert materials and fly ashes (see Table 3). Assuming that inert materials do not change their exhalation rate when imbedded in concrete, cement emanating powers after hydration can be calculated. Cements after combination show emanating power values in a narrow range from 55 to 59%

(average value 56.8%) for concrete slabs made with different kind of cement and inert materials. Now, assuming that a) inert materials do not change their emanation properties when they are in concrete and b) cements have an emanation power of 56.8%, fly ashes radon emanation power values inside the concrete (see Table 4 columns 8 and 9) range from 11.2 to 21.9% (average value 17%). Fly ashes show an increase from 1 to 17% which is similar to that showed by cements (from about 4 to 57%).

CONCLUSIONS

The investigation carried out on Italian building materials has shown a substantial homogeneity in natural radioactive levels, except for volcanic materials (tuff, pozzolana, etc.). As far as exhalation rate values are concerned coal ashes are at an intermediate level between portland cements and pozzolanic cements.

Tests on concrete with fly ashes show that there is a slight increase in radon emanation but the radiological hazard connected with the use of fly ashes in the building industry seems to be negligible taking into account that the incidence of radon exhaled by building materials on indoor radon levels can be estimated in the 10-20% range⁽⁶⁾⁽⁷⁾ of the total indoor concentration.

REFERENCES

- 1) Morawska L. Health Physics 57 (1):23-27 (1989).
- 2) Jonassen N. Health Physics 45:369-376 (1983).
- 3) Thomas J.W., Countess R.J. Health Physics 36:734-738 (1979).
- 4) Van der Lugt, Scholten L.C. The Science of the Total Environment 45:143-150 (1985).
- 5) Semkow T.M. Geochimica et Cosmochimica Acta 54:425-440 (1990).
- 6) Quindos L.S., Newton G.J., Wilkening M.H. Health Physics 56:107-109 (1989).
- 7) Battaglia A., Capra D., Queirazza G., Sampaolo A. Radon exhalation rate from ashes and building materials in Italy Presented at the: Twenty-Ninth Hanford Symposium on Health and the Environment - Indoor Radon and Lung Cancer: Reality or Myth? - Richland, Washington (USA) - October 16-19, 1990.

Table 1 - Natural radionuclides concentrations in building materials and coal ashes (average \pm st.dev.).

Material	²²⁶ Ra [Bq/kg]	²²⁸ Ra [Bq/kg]	⁴⁰ K [Bq/kg]
Portland cements (31 samples)	26 \pm 15	18 \pm 12	210 \pm 40
Pozzolanic cements (21 samples)	49 \pm 26	45 \pm 38	390 \pm 200
Sands and gravels (61 samples)	15 \pm 6	17 \pm 11	390 \pm 230
Bricks (124 samples)	40 \pm 17	40 \pm 16	710 \pm 210
Hydrated limes (13 samples)	10 \pm 5	2.2 \pm 2.7	77 \pm 130
Peperinos (6 samples)	160 \pm 50	190 \pm 70	1420 \pm 130
Pozzolanans (15 samples)	210 \pm 130	250 \pm 150	1660 \pm 430
Tuffs (26 samples)	160 \pm 120	200 \pm 140	1640 \pm 510
Ashes (151 samples)	170 \pm 40	140 \pm 40	410 \pm 190
Fly-ashes USA (71 samples)	170 \pm 40	130 \pm 30	470 \pm 100
Fly-ashes South Afr. (70 samples)	170 \pm 40	150 \pm 40	330 \pm 210
Bottom ashes (10 samples)	130 \pm 30	100 \pm 20	470 \pm 290

Table 2 - Exhalation rates and emanating powers of building materials and coal ashes (average ± st.dev.).

Material	Exhalation rate [$\mu\text{Bq kg}^{-1} \text{ s}^{-1}$]	Emanating power [%]
Portland cements (21 samples)	2.1 ± 1.2	5.2 ± 4.0
Pozzolan cements (15 samples)	9.3 ± 6.7	8.8 ± 4.2
Sands and gravels (31 samples)	2.1 ± 1.4	8.4 ± 3.7
Bricks (30 samples)	1.3 ± 1.0	1.7 ± 1.5
Hydrated limes (6 samples)	1.2 ± 0.4	8.6 ± 5.3
Coal ashes (34 samples)	5.4 ± 3.6	1.6 ± 1.4
Fly-ashes South Afr. (19 samples)	4.5 ± 2.2	1.3 ± 0.7
Fly-ashes USA (10 samples)	6.4 ± 4.0	1.6 ± 0.8
Bottom ashes (5 samples)	6.8 ± 5.4	2.9 ± 3.0

Table 3 - Radiological characteristics of materials used to make 20x20x10 cm concrete elabs. Emanating power values in column 4 marked with * are referred to calculated values for cement embedded in concrete assuming that inert materials do not change their exhalation rate.

Material		^{226}Ra [Bq kg^{-1}]	Exhalation rate [$\mu\text{Bq kg}^{-1} \text{ s}^{-1}$]	Emanating power [%]
Portland cement (4 samples)		13.9±19.9	0.8±2.7	2.1±6.9
Inert	White limestone	3.1	0.51	7.8
	Sand and gravel	17.4	2.5	6.8
Concrete with both kinds of above inert material		4.1±5.5	2.6±5.5	16±33 (55±59)*
Fly ash	USA	175	3.7	1.0
	South Africa	150	3.5	1.1

Table 4 - Radiological characteristics of 20x20x10 cm concrete slabs made using sand and gravel as inert materials and different percentage of fly ash with respect to cement. Emanating power values in the last column are calculated assuming that inert materials exhalation rate does not change and cement exhalation rate is 56.8%.

Fly ash percentage [%]	Measured exhalation rate [$\mu\text{Bq kg}^{-1} \text{ s}^{-1}$]		^{226}Ra [Bq kg^{-1}]		Concrete emanating power [%]		Fly ash emanating power [%]	
	South Africa	USA	South Africa	USA	South Africa	USA	South Africa	USA
0	5.49		16.16		16.2		---	---
5	5.63	5.77	16.97	13.14	15.8	20.9	14.5	17.3
15	6.01	5.74	18.10	13.22	15.8	20.7	17.3	11.2
26	6.63	6.65	18.87	13.27	16.7	23.9	20.6	17.8
40	7.20	6.81	19.35	13.33	17.7	24.3	21.9	16.3

**RADON SURVEY IN
METROPOLITAN TORONTO SCHOOLS**

Ernest Becker* and Reza Moridi*

Canadian Institute for Radiation Safety (CAIRS)
*CAIRS National Laboratories, Saskatoon, Saskatchewan, Canada
+CAIRS National Office and Centre for Public Education, Toronto,
Ontario, Canada

ABSTRACT

The radon testing survey in Metropolitan Toronto public schools was the most intensive project of its kind ever undertaken in Canadian schools. It also included an extensive public education program on radiation and radon-in-schools.

The radon levels at 632 schools were measured using the CAIRS Radon Monitors. Ninety per cent of the locations measured were found to have a radon level equal to or less than 2 mWL. Two locations in two different schools were found to have a radon level at or above the Action Level (20 mWL). The remaining results were between the two extremes. Follow-up testing in those schools where more than 10 mWL of radon was found is in progress.

INTRODUCTION

Radon is produced by the radioactive disintegration of uranium which occurs naturally in soil and rocks. Radon gas moves through the earth and can seep into the air in buildings (1). It is well established (primarily through studies of uranium miners) that exposure to radon progeny may cause lung cancer (2).

CAIRS has screened all public schools in Metropolitan Toronto for radon. The project was carried out in two phases:

1. The initial phase was a pilot project conducted in 37 schools in early 1990. The purpose of this test was to check the screening procedures.
2. The purpose of the second phase, conducted in 1990-91, was to screen the remaining 595 schools and buildings.

In total, 2774 locations were tested for radon (3).

PROCEDURES

The intent of the initial screening was to determine if there were any high radon levels in a school. For this reason, rooms and areas that were likely to have elevated radon levels were selected. These included:

1. Basement classrooms

2. Occupied rooms which are isolated from the central ventilation system and in which only the room air is recirculated
3. Rooms on or near structural joints such as adjacent slabs
4. Rooms with a large floor/wall joint perimeter and appreciable gaps in this joint
5. Rooms that have floor slabs with significant cracks

After inspecting each school building and applying the above protocol, suitable locations for radon testing were identified and marked on the school floor plan.

CAIRS Radon Monitors, which are active alpha detectors, were delivered to each school in separate boxes. All monitors were numbered and labeled according to the Area Board of Education, school and monitoring location. The data tags were attached to the monitors.

About 700 school Chief Caretakers and other officials had education on radon-in- schools and were trained in procedures under the CAIRS public education program. The Chief Caretakers, following detailed instructions, placed the monitors at the designated locations on tables or shelves at a height of about 50-70 cm above floor level. As well, the monitors were placed away from radiators, hot air registers and draughty windows.

Testing was carried out during the winter when interior radon levels are generally higher. Because radon levels fluctuate, the monitors ran for seven days continuously to ensure a reliable average reading. At the end of the testing period, the monitors were returned to CAIRS for analysis.

QUALITY CONTROL

In order to maintain the quality of the testing program, various quality control measures were employed.

1. Inspection of Monitors

All monitors were inspected during the first or second day of the testing period in order to ensure that all the placement procedures were followed properly.

2. Duplicate Monitors

Duplicate monitors were placed side by side in one per cent of all locations monitored. These locations were selected randomly. The duplicate monitors were shipped, installed, stored, processed and analyzed under the same conditions as the primary monitors.

In 46% of these locations, both the primary and duplicate monitors produced exactly the same results. In the remaining cases the variation between the readings of the primary and duplicate monitors was very small.

3. Control Detectors

In order to determine the radon exposure that accumulated during the shipment and storage of monitors, twenty fresh detectors were selected as "field blanks". None of these detectors showed any reading above the lower limit of detection of the monitors.

4. Calibration

Monitors were calibrated regularly at the CAIRS Radon Calibration Facilities. Air flow measurements of the monitors were taken before and after the testing period. The air flow meter used in these measurements was also calibrated using a bubble tube and a stop watch.

THE CAIRS RADON MONITORS AND LABORATORY ANALYSIS

The CAIRS Radon Monitor is a Radon Progeny Integrating Sampling Unit.

The monitor head originally developed by the French Atomic Energy Commission (CEA) is, in essence, an alpha particle spectrometer capable of detecting separately the alpha particles from radon and thoron daughters (4). The alpha particles are detected by damage tracks they create on a film.

The films were etched chemically in 2.5 N NaOH solution at 60.0 C for 90 minutes inside a constant temperature bath. The tracks were counted using an image analysis system comprised of a Nikon camera, microscope and an Arteck counter. The data was fed into a computer and the radon levels were calculated.

The lower and upper limits of detection of the monitors are about 0.5 and 1,000 mWL respectively. The CAIRS Radon Monitor has passed Round 6 in the National Radon Proficiency Test of the U.S. Environmental Protection Agency.

RESULTS AND DISCUSSIONS

Table 1. Number of schools and locations monitored for radon

School Boards	Number of schools	Number of monitored locations
East York	28	102
Ethiocoche	87	405
French Language	4	22
MTSB	9	28
North York	158	663
Scarborough	167	786
Toronto	142	598
York	37	170
Total	632	2,774

Table 1 shows the number of schools and the number of monitored locations in each of the eight school boards within Metropolitan Toronto.

Figure 1 illustrates the distribution of the number of locations monitored. On average about five locations were monitored in each school.

Figure 2 illustrates the distribution of radon levels at all locations monitored. 90% of locations

monitored had a radon level equal to or less than 2 mWL.

Two schools were found with readings at or above the CAIRS recommended Action Level of 20 mWL. Three schools had readings

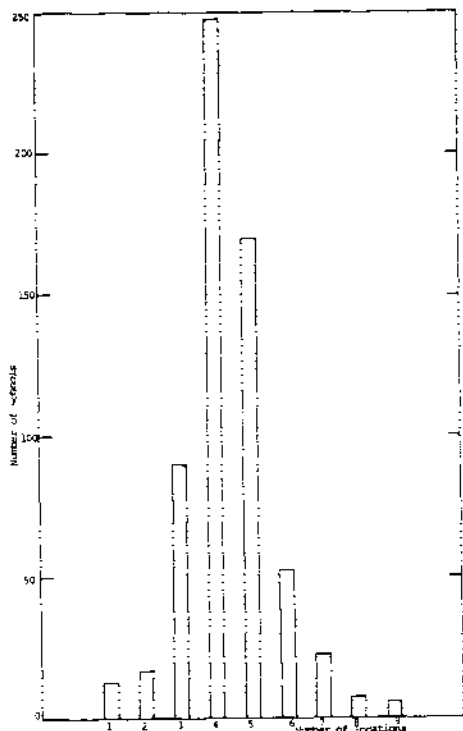

Figure 1. Distribution of the number of locations monitored.

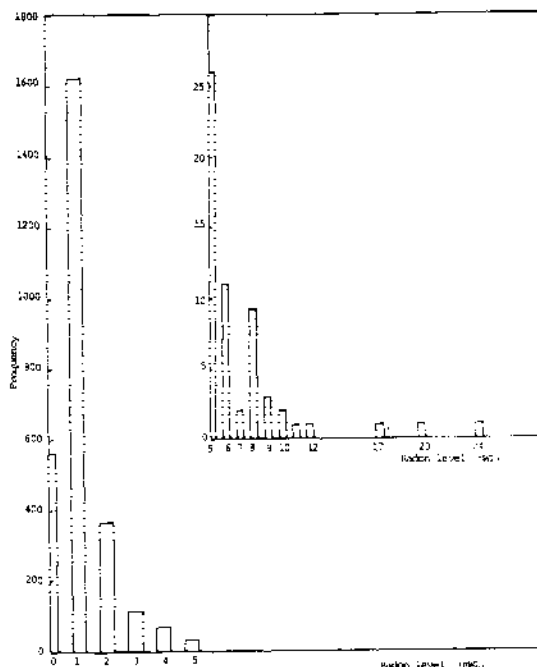

Figure 2. Distribution of radon levels at specific locations

at the intermediate level (10-20 mWL). (Follow-up testing in these schools is underway.) Apart from these elevated levels, the remaining locations demonstrated a radon level below the action level.

REFERENCES

1. Becker, E., 1991, Radon in the Home, 2nd ed., CAIRS, Toronto.
2. Radon in Schools, Questions and Answers, 1990, CAIRS, Toronto.
3. Radon in Schools, A Report prepared for the Public School Boards in Metropolitan Toronto, 1991, CAIRS, Toronto.
4. Becker, E., 1988, A Modified Alpha Dosimeter for Canadian Uranium Mines. A Report prepared for the Atomic Energy Control Board, Canada., CAIRS, Toronto.

ACKNOWLEDGEMENT

We wish to thank the Metropolitan Toronto School Boards (MTSB) for their permission to publish the results of the project. We are also grateful to Dr. Fergal Nolan, President and CEO of CAIRS, for his guidance and keen interest in this work. The collaboration of CAIRS and MTSB project teams on this program is greatly appreciated.

RECONSTRUCTION OF
THE RADON DAUGHTER EXPOSURE OF BEAVERLODGE URANIUM WORKERS

D.B.Chambers, R.H. Stager, F.D. Bernard, L.M. Lowe
SENES Consultants Limited
52 West Beaver Creek Road
Richmond Hill, Ontario
L4B 1L9

ABSTRACT

The lung cancer mortality of uranium mine employees at the Eldorado Beaverlodge mine in Northern Saskatchewan is an important source of data on the risks from exposure to radon daughters. This study presents a year by year re-evaluation of mine area and mine wide radiation levels. The analysis of a case control study group suggests that exposures have been underestimated in previous studies. Potential sources of bias and of uncertainty in the estimation of exposure are also discussed.

INTRODUCTION

This study was performed for the Atomic Energy Control Board of Canada (AECB) with the objective of investigating available data and developing independent estimates of workplace radiation levels and of worker exposures to radon daughters (1). Cameco (Eldorado's successor) provided records covering the period from early exploration to mine closing. Many types of data were provided, including operating statements, ventilation reports, radon and radon daughter measurement data, bonus contracts, previous exposure calculations and personnel records for employees in a previous case control study. As could be expected, the extent of information was more substantial in the later years than for the earlier periods.

Dr. G.R. Howe of the NCIC identified employees for a new case control study group of 195 men consisting of 65 lung cancer cases and 130 controls, with controls matched only by year of birth. The identification of employees with respect to cases or controls was not known to the study team during the exposure estimation.

APPROACH

Preliminary investigations suggested that regression models performed well for some data sets. However, explanatory variables for the regression models were not consistently available over the period of investigation. The

approach eventually adopted involved weighted averaging of the data. Since radon daughter concentrations vary widely between different time periods and locations within a mine, the analyses were performed at as detailed a level as possible, namely, the specific month and location of exposure.

The radiation measurements were merged with the production statistics by specific month and specific workplace. For each month, the radiation measurements in the workplace were averaged and the man shifts worked was estimated. Man shifts were determined by dividing the production (tons ore broken or lineal feet advance) in a workplace by the mine wide index of production per man shift. Annual radon daughter concentrations for each workplace were estimated as the weighted average radon daughter concentrations where the weights are the number of man shifts worked in the month. Workplace radon daughter concentrations were aggregated to mine area and mine wide concentrations by weighting the annual radon daughter concentrations by the total man shift durations in each workplace.

Radon daughter exposures were estimated for the 195 employees (selected by Dr. Howe) using 9 work type classifications (including 6 underground work categories). For a sample from the case control group, the bonus contracts were inspected to try to find their exact workplace location by month. Exposures developed on this basis differed substantially from the mine-wide estimate for the workplace type for some of the sample. The analysis suggests that the use of mine wide radon daughter concentrations may substantially over or under estimate individual exposures.

RESULTS

The mine wide radon daughter levels, averaged over all types of underground employees, calculated in this study are shown in relation to previous estimates in Figure 1. Overall, the new estimates are somewhat higher than the previous estimates (i.e. those presented by Frost, (2) and used as the basis of the studies reported by Howe et al. (3)) which were essentially medians of the data. Annual estimates based on simple averaging of the data, generally form an upperbound on the new estimates.

A large number of the employees within the case control study group had very low exposures. This partly arose from short employment durations, in the order of less than a year for many of the employees. Additionally, many of the employees did not work underground at any time. Overall, only 62 of the employees were found to have some underground exposure and worked more than 1 year.

The effect of the aggregation of work place radon daughter concentration estimates in the presence of variability between workplaces is illustrated in Figure 2 for 1963 stope data. Moving from the mine wide weighted average for stopes (left side of figure) to individual work areas (right side of figure), results in a dramatic increase in the differences between the minimum and maximum workplace values. As workers were known to work in individual mine areas for extended periods of time, the agglomeration of data results in the loss of important information, and introduces significant uncertainty to the exposure estimates.

Other sources of uncertainty (and potential bias) in worker exposure estimates include: uncertainty about the radon to radon daughter ratio in the early years of mining, uncertainty about time spent in individual workplaces, changes to ventilation and mining practices that occurred over time, and other mining experience. Several of the underground miners were found to have records of working at other uranium mines in the Beaverlodge area.

CONCLUSIONS

Based on the experience of case control group, previous estimates of exposures to radon daughters arising from Eldorado Beaverlodge work experience alone were too low by about 50%.

There is considerable residual uncertainty about workplace exposure conditions and the exposure of individual employees due to the substantial difference of radon daughter concentration between workplaces. The analysis suggests that the individual employees may have exposures that differ by a factor of 2 or 3 from the assigned exposures.

It is highly likely that many of the miners incurred significant radon daughter exposure from non-Eldorado Beaverlodge mining work.

REFERENCES

1. SENES Consultants Limited, 1991. "Detailed Reconstruction of Radon Daughter Exposures of Eldorado Beaverlodge Uranium Mine Employees." Prepared for the AECB.
2. Frost, S.E., 1983. "Beaverlodge Working Level Month Calculations (Draft No. 4)." Eldorado Resources Limited.
3. Howe, G.R. et al., 1986. "Lung Cancer Mortality (1950-1980) In Relation to Radon Daughter Exposure in a Cohort of Workers at Eldorado Beaverlodge Uranium Mine." J. Nat. Cancer Inst., Vol. 77, No. 2, pp. 357-362.

FIGURE 1: COMPARISON OF STUDY RADON DAUGHTER CONCENTRATION ESTIMATES TO PREVIOUS ESTIMATES

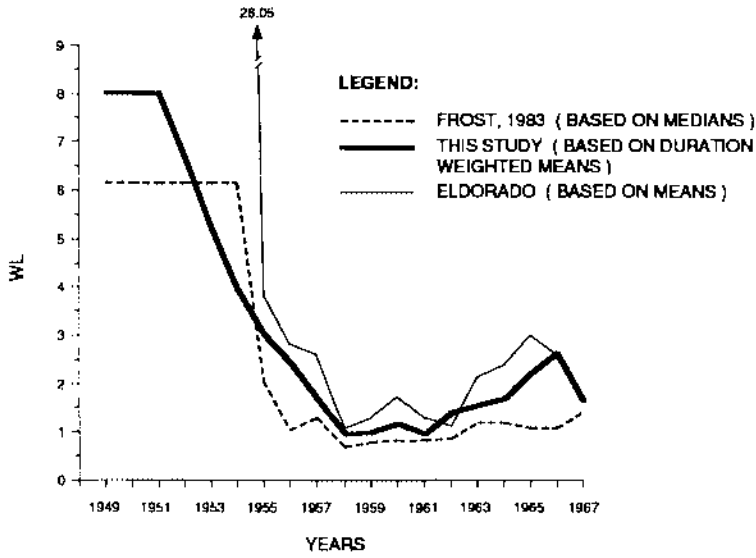
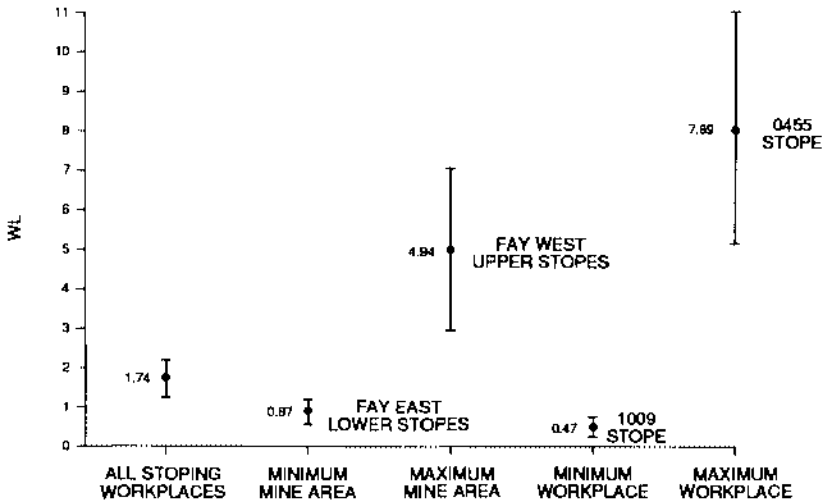

FIGURE 2: ESTIMATES OF 1963 MEAN RADON DAUGHTER CONCENTRATION (WL) BY LEVEL OF AGGREGATION OF STOPING WORKPLACES



MATHEMATICAL MODEL FOR CALCULATION OF THE LUNG DOSE FROM INHALED
RADON-222 AND ITS DAUGHTERS

Dragoslav Nikezić and Petar Marković

Faculty of Natural Sciences, 34000 Kragujevac, Yugoslavia

ABSTRACT. A mathematical model of a human lung is described in this paper. Result obtained using by this model were compared with data taken from references.

INTRODUCTION

Inhalation of radon and its short lived daughters leads to the population absorbed dose which is under "normal situations" larger than any other component due to the natural radiation. In order to estimate corresponding risk one needs to relate measurable quantities, such as are concentrations of radon and its daughters in air, etc., with the absorbed dose in the human respiratory tract. There are few parameters upon which the dose in respiratory tract depends. In this paper we describe a mathematical human lung model we have developed and used and which enabled us to examine lung dose dependence on different relevant parameters.

MODEL

The developed mathematical human lung model is used for calculations of absorbed dose in the layer of basal cells per unit exposure to radon daughters in the whole T-B tree. This quantity is named "alpha dose factor" ⁽¹⁾. A computer program, called LUNGDOS was made to carry out calculations by using this model. The basic characteristics of the used approach are as follows:

-Yeh-Schum's geometrical model of the human lung was used ⁽²⁾;
-In order to calculate distance from the mucus layer to the basal cells the Gastineau's distribution ⁽³⁾ of the bronchial epithel thickness was used.

-It was assumed that α -emitters were distributed homogeneously in the mucus layer.

-Expression for the α -particles stopping power calculation in the tissue and air was taken over from reference ⁽⁴⁾.

-Radioactive aerosol deposition was calculated by using Landahl formula ⁽⁵⁾ in the first six generations, and Gormley-Kenedy equation ⁽⁶⁾ for the rest of T-B tree.

-Clearance of the deposited radioactive aerosols is carried out by mucus movement upwards toward the nose and mouth. The data for the mucus speed was adopted from reference ⁽⁴⁾. Radioactive aerosol transport is the second important process which influences radioactivity decrease in the T-B tree. The transfer of the radioactive aerosols depends on their chemical form. According to reference ⁽⁷⁾ there is a "fast phase" which is transferred from T-B tree to the blood with transfer half time of 50 min (10%), and three slower phases with an average of transfer half times of 3^h (35%), 9^h (35%) and 45^h (10%), and about 10% is unknown.

In accordance with this it was estimated that the average half-transfer time into the blood was 3^h for the whole of the T-B tree, regardless of the bronchial generation.

According to the so far said four processes are responsible

for the radon progeny activity in the T-B tree. They are: deposition, decay, clearance by the mucus movement and transfer to the blood. All these processes together lead to establishment of activity equilibrium in each bronchi of the T-B tree.

One needs to calculate the equilibrium activity in each bronchi of T-B tree. In order to do this it is necessary to set up and solve a set of differential equations of the 1st order, such as

$$dN_{ij}/dt = B_{ij}/\lambda_i + A_{i-1,j} + \lambda_{c,j+1} N_{i,j+1} - (\lambda_i + \lambda_{c,j} + \lambda_k) N_{ij} \quad (1)$$

In equation (1) N_{ij} is the number of atoms of i^{th} radon daughter in the bronchi of the j -th generation; B_{ij} is deposition rate of the i -th progeny in j -th generation, given in Bq/s; λ_i is decay constant of the i -th radon progeny; A_{ij} is equilibrium activity of the i -th radon progeny in the j -th bronchi generation; $\lambda_{c,j}$ is the clearance constant by the mucus and λ_k is transfer constant to the blood. The solutions of the above differential equations are as follows:

$$A_{ij} = (\lambda_i A_{i-1,j} + \lambda_{c,j+1} A_{i,j+1} + B_{ij}) / (\lambda_i + \lambda_{c,j} + \lambda_k) \quad (2)$$

$i=1,2,3; j=1,1B$

System of equations (2) is solved by starting with the first progeny ($i=1$), from sixteenth (brochi) generation. The procedure is then repeated for $i=2$, and $i=3$. After that one repeats the whole procedure for 15th generation. In order to solve the set of equation (2) it is necessary to know the deposition rate of the i^{th} progeny in the j^{th} generation. The entire described procedure is programmed and is a part of the program LUNGDOSE.

Equilibrium activities calculated in the just described way were calculated with corresponding conversion factor ⁽⁸⁾, in order to obtain the absorbed dose in the layer of the basal cells, for given bronchi.

RESULTS

Among many obtained results by using the described model, we presented here two- dose dependence on the aerosol diameter and on breathing rate.

-aerosol diameter-

The value of the median diameter of aerosols was varied and α - dose factor was calculated for whole T-B tree. Deposition of aerosols in T-B tree decreases with its diameter increase, and that is the reason that the dose factor decreases with increase of the diameter. Results are shown graphically on Figure 1, parallelly with result from references ⁽⁹⁾ and ⁽¹⁰⁾. For aerosols diameter of 0.1 μm the value obtained in this work is among the referent values, while for larger diameters thi value is for about 10 % higher. That comes from the difference in assumed breathing rate. In this work that velocity was 0.3 m^3/ks , while referent values were 0.2 m^3/ks .

Breathing rate

Dependance of the average dose factor for T-B tree as a whole on breathing rate was examined in this work too. Obtained results are shown in Fig.2. One can see a linear increase of the dose factor with increase of the breathing rate. For a change of the breathing rate from 0.11 to 0.38 m³/ks (0.4 to 1.4 m³/h) the dose factor increases from 0.27 up to 0.4 mGy/(J·s·m⁻³). On the same figure are shown several data calculated based on (or simply taken from) different references^{(1),(9),(10),(11)}. All models are showing similar behaviour of the dose factor as a function of the breathing rate. However, there is a rather large difference in absolute values for different models. This difference comes from the difference in assumed value of the epithelial depth. Results of our work presented by the full line on Figure 2, agree rather well with results of reference⁽¹⁰⁾, beside that the line obtained in this work is with somewhat smaller slope.

REFERENCES

1. Harley, N.H., Pasternack, B.,S., 1982. Environmental Radon Daughters Alpha Dose Factors in a Five-lobed Human Lung, Health Physics 42, pp.789-799.
2. Yeh, H.C., Schum, G.M. 1980. Models of the Human Lung Airways and their Applications to Inhaled Particle Deposition, Bull.Math. Biol. 42, pp.461.
3. Gastineau, R.M., Walsh, P.J., Underwood,N., 1972. Thickness of Bronchial Epitelium with Relation to Exposure to Radon", Health Physics 23, pp.857-860.
4. Harley, N.H., Pasternck, B,S. 1972. Alpha Absorption Measurements Applied to Lung Dose from Radon Daughters, Health Physics 23, p. 771-782.
5. Landahl, H.F., 1963. Particle Removal by the Respiratory Sistem, Bull. Math. Biophys. 12,p.43.
6. Gormley, P.G., Kennedy, M., 1949. Diffusion from a Stream Flowing Through a Cylindrical Tube, Proc. R. Irish Acad. A 52, 163.
7. Hofman, W., 1982. Dose Calculation for Respiratory Tract from Inhaled Natural Radioactive Nuclides as a Function of Age, Health Physics 43, pp.31.
8. Nikezić, D., 1990. Experimental and theoretical study of the indoor exposure. University S.Marković, Kragujevac, Yugoslavia, 1990. Thesis. (in Serbian).
9. James, A.C., Jacoby, W., Steinhausler, F., 1982. Respiratory Track Dosimetry of Radon and Thoron Doughters, Rad. Hazards in Mining (ed M.Gomez), Soc. Min. Eng, New York p.42.
10. Jacobi, W., 1984. Possible Lung Cancer Risk from Indoor Exposure to Radon Daughters", Radiation Protection Dosimetry, 7,
11. Jacobi, W., Eisfeld, K., 1980. Dose to Tisuess and Effective Dose Equivalent by Inhalation of Rn-222, Rn -220 and their short lived Daughters, GSF reports S-626.

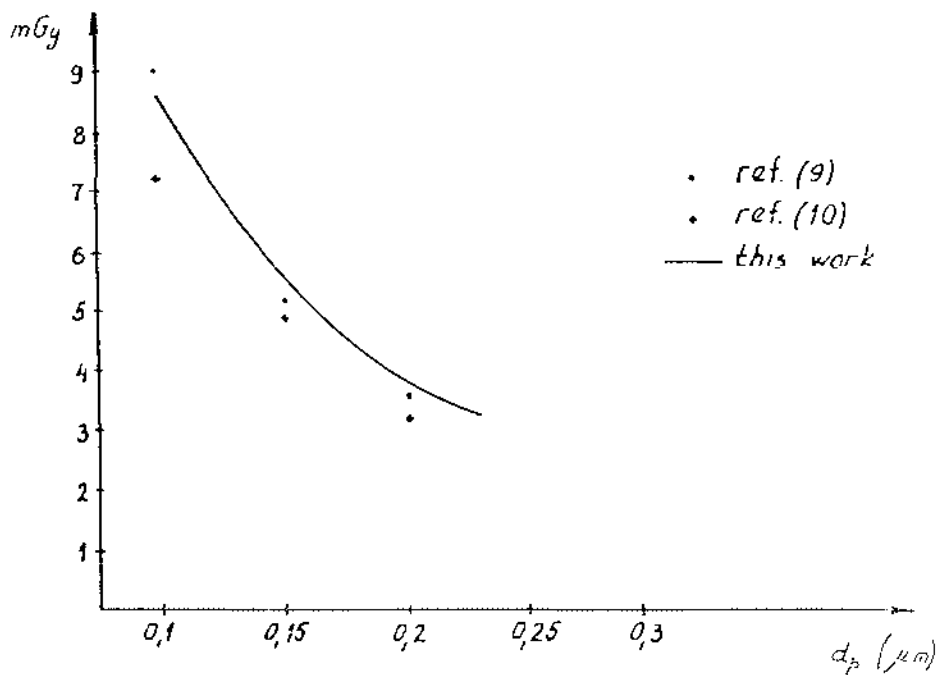

FIG.1. Alpha dose factor dependence on particle diameter

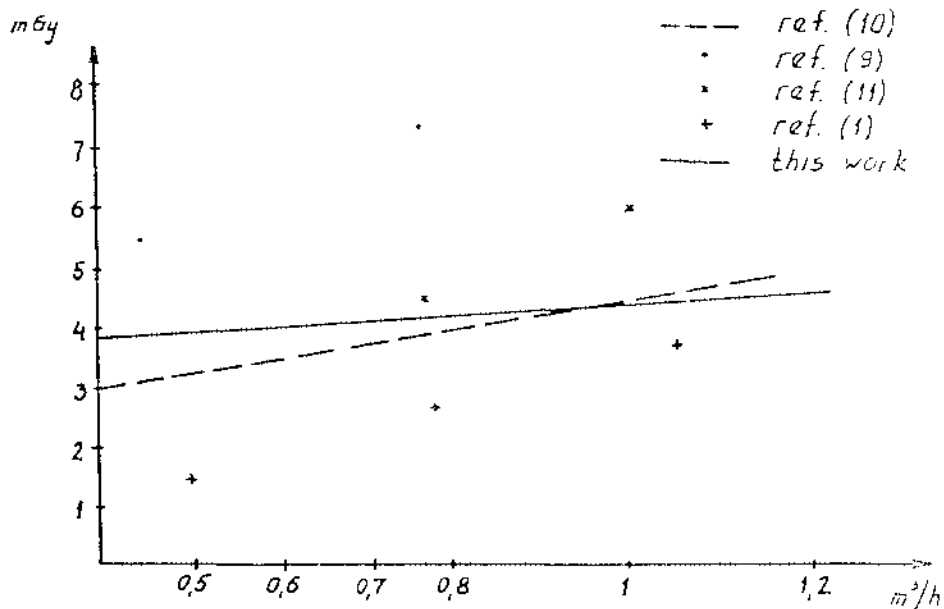

FIG.2. Alpha dose factor dependence on breathing rate

CALCULATIONAL AND EXPERIMENTAL DETERMINATION OF THE CALIBRATION
COEFFICIENT FOR RADON MEASUREMENTS USING LR-115 DETECTOR IN A
DIFFUSION CHAMBER

Petar Marković^{*†} and Dragoslav Nikezić^{*}

^{*} Faculty of Natural Sciences, Department of Physics, 34000 Kragujevac

[†] "Boris Kidrič" Institute of Nuclear Sciences, Belgrade, Yugoslavia

ABSTRACT

Experimentally and calculationaly obtained data for calibration coefficient for radon measurements using LR 115 II detector in the diffusion chamber were given in this paper. Monte Carlo Method was used for calibration coefficient calculation.

INTRODUCTION

Radon measurements with bare (open) track detector are rough and with rather high uncertainties. This is due to the fact that calibration coefficient, k , which relates track density, ρ , per unit exposure time with average radon concentration, C , during exposure period, given by equation (1),

$$C = k\rho \quad (1)$$

depends on equilibrium factor among radon and its short living daughters. One usually needs to determine radon concentration independently on the equilibrium factor. Diffusion chambers are usually used for that. Diffusion chamber in this case is a vessel covered with a piece of filter paper, or some other permeable foil.

Usually, detector is fixed on the bottom of the diffusion chamber. Radon diffuses through the filter paper into the chamber. Its half life (3,825 d) is sufficiently large, so that filter paper is not some important obstacle for radon, while radon daughters can not enter into the diffusion chamber. Radon which enters the chamber, decays in it. Daughters formed inside the chamber can not leave it, so that an equilibrium between radon and its daughters establishes in the chamber. Their activities are equal; $A_{Rn}^{222} = A_{Po}^{218} = A_{Pb}^{214} = A_{Po}^{214} / \lambda_{Bi}^{214}$. However, this does not mean that their activities in the air in the chamber are equal. Process which disturb the equilibrium in the air is plate out effect, namely the deposition of the radon daughters onto the inner wall surfaces of the chamber. One can take that inside the chamber all ^{222}Rn atoms are in the air, while the atoms of the daughters elements are partially in the air, and partially are deposited onto the inner surfaces of chamber's walls.

Activities of the i^{th} radon daughter ($i=1,2,3$) in the chamber, which is the sum of the activities in the air and on the wall surface, is equal to the radon activity.

The radon daughters deposition changes the detector exposition geometry, so that the track density and calibration coefficient would be changed.

Calibration coefficient (and track density vs.) depends on

the yield of deposited radon daughters. That dependence is actually subject of this paper. Track densities were calculated under different assumption and compared with experimental data. Monte Carlo method has been used for these calculations.

CALCULATIONAL RESULTS

Detector track density was calculated using TRACKO and TRACKO1 programs ^{(1),(2),(3)}.

A conical diffusion chamber with base diameters of $R_1=2.6$ cm and $R_2=3.4$ cm and high $h=8.4$ cm was used.

Calculations were performed for rectangular detector LR-115-II, whose dimensions were 2×1 cm². Detector was placed on the bottom of the diffusion chamber and center of the detector was hatched with the center of the chamber bottom. Calculations were performed for the $4.7 \mu\text{m}$ of removed detector layer for two extreme cases;

a) no radon daughters depositing on the walls of the chamber, and

b) all radon daughters were deposited before decay.

Track densities for both cases were calculated and the following results were obtained:

Case a)

$$\begin{aligned} \rho_{Rn} &= 3.5810^{-3} \text{ track} \cdot \text{m}/(\text{Bq} \cdot \text{s}), \\ \rho_{a1} &= 3.2410^{-3} \text{ track} \cdot \text{m}/(\text{Bq} \cdot \text{s}) \\ \rho_{a3} &= 2.3110^{-3} \text{ track} \cdot \text{m}/(\text{Bq} \cdot \text{s}); \end{aligned} \quad (2)$$

in which index "a" denote that alpha particles due to the emitters placed in the air; ρ_{Rn} is the track density due to α particles emitted by radon and, ρ_{a1} and ρ_{a3} are track densities due to the α particles from ^{218}Po , and ^{214}Po respectively. The total track density ρ_{ta} is the sum of partial track densities

$$\rho_{ta} = \rho_{Rn} + \rho_{a1} + \rho_{a3} = 9.31 \cdot 10^{-3} \text{ track} \cdot \text{m}/(\text{Bq} \cdot \text{s}) \quad (3)$$

Corresponding calibration coefficient is just the reciprocal value of total track density:

$$k = 1/\rho_{ta} = 109.5 \text{ Bq} \cdot \text{s}/(\text{track} \cdot \text{m}). \quad (4)$$

In the case b), when all radon daughters decay after deposition, we obtained values for track densities as follows:

$$\begin{aligned} \rho_{w1} &= 1 \cdot 10^{-4} \text{ track} \cdot \text{m}/(\text{Bq} \cdot \text{s}), \\ \rho_{w3} &= 1.43 \cdot 10^{-3} \text{ track} \cdot \text{m}/(\text{Bq} \cdot \text{s}), \end{aligned} \quad (5)$$

where by the index "w" denotes that alpha emitters were situated on the walls surface. Total track density ρ_{tw} in this case is:

$$\rho_{tw} = \rho_{Rn} + \rho_{w1} + \rho_{w3} = 5.11 \cdot 10^{-3} \text{ track} \cdot \text{m}/(\text{Bq} \cdot \text{s}), \quad (6)$$

and the corresponding calibration coefficient:

$$k=1/\rho_{tw}=195.7 \text{ Bq}\cdot\text{s}/(\text{track}\cdot\text{m}) \quad (7)$$

Deposition of radon daughters, causes decreasing of the track density for a factor of 2 (see equation 3 and 6). Track density decreasing is especially conspicuous for the alpha particles energy of 6 MeV of ^{218}Po . The reason for so high decrease was the smaller ranges of this alpha particles, which were not able to expose the whole detector.

It could be taken that calibration coefficient for rectangular detector, dimensions $2 \times 1 \text{ cm}^2$, takes a value between 110 and 195 $\text{Bq}\cdot\text{s}/(\text{track}\cdot\text{m})$.

For more precise determination of the calibration coefficient it was necessary to determine that part of radon daughters which was deposited on the chamber walls. This was done by comparing experimentally and calculationaly obtained data for track density distribution on the track detector which covered the bottom of the chamber⁽³⁾. It was concluded that part of deposited ^{218}Po yielded 3/5; so the part of ^{218}Po which decay before depositing, amounts 2/5.

Radon daughters ^{214}Pb and $^{214}\text{Bi}/^{214}\text{Po}$ have a much longer half life, and we adopted that they deposited completely before decay. This means that f_3 could be close to zero, eg. $f_3 \approx 0$. Finally, the detector track density could be obtained from the following expression:

$$\rho_t = \rho_{Rn} + f_1 \rho_{a1} + f_3 \rho_{a3} + (1-f_1) \rho_{w1} + (1-f_3) \rho_{w3} \quad (8)$$

Where are:

f_1 - part of i-th radon daughter in the chamber air volume,

$1-f_1$ - part of i-th Rn daughter deposited on the wall surface,

For rectangular detector in the diffusion chamber, which was used in our environmental study, the following values were obtained:

$$\begin{aligned} \rho = \rho_{Rn} + \frac{2}{5} \rho_{a1} + \frac{3}{5} \rho_{w1} + \rho_{w3} &= 3.58 \cdot 10^{-3} + \frac{2}{5} \cdot 3.24 \cdot 10^{-3} + \\ + \frac{3}{5} \cdot 1 \cdot 10^{-4} + 1.43 \cdot 10^{-3} &= 6.37 \cdot 10^{-3} \text{ track}\cdot\text{m}/(\text{Bqs}) \end{aligned} \quad (9)$$

So, the calibration coefficient will be:

$$k=1/\rho=157 \text{ Bq}\cdot\text{s}/(\text{track}\cdot\text{m}) \quad (10)$$

EXPERIMENTAL RESULTS

A direct calibration experiments were performed in order to obtained the values of k and ρ . A set of five diffusion chambers, were prepared with rectangular (2×1) cm^2 detectors. Diffusion chambers were exposed to the high radon concentration, during one to seven weeks. Radon level concentration were measured using the scintillation cells. An average radon concentration during exposure period was $(6900 \pm 450) \text{ Bq}/\text{m}^3$. Detectors were etched under the following condition, (10% solution of NaOH on 60°C , during 2^h). Track density measurements were done with optical microscope. The results of this experiment are given in Table 1.

Table 1.

The results of calibration coefficient measurements, for ^{222}Rn determination with rectangular (2x1) cm² LR-115-II detector, placed on the bottom of the diffusion chamber

duration of the exposition [days]	track density track/m ² /s	calibration coefficient k Bq·s/(track·m)
7	46	150
14	47	146
14	43	159
28	44	155
49	39	172

The average value for the calibration coefficient obtained from this measurements, is 156.4 Bq·s/(track·m), with uncertainty about 20 Bq·s/(track·m).

In this way the final experimental results for the calibration coefficient using the LR-115-II track etch detector in diffusion chamber is:

$$k=(156\pm 20) \text{ Bq}\cdot\text{s}/(\text{track}\cdot\text{m}) \quad (11)$$

CONCLUSIONS

In conclusion it could be said that calculational results for the calibration coefficient taking into account the deposition on the chamber walls, agrees very well with value obtained experimentally. Further, this calculational model can be used to estimate the amount of deposition of radon daughters on the walls by knowing the detector track density distribution, what enable us to determine more realistic calibration coefficient.

REFERENCES

1. Nikezić, D., 1990. Experimental and theoretical study of the indoor exposure, University S.Marković, Kragujevac, Yugoslavia, Thesis, (in Serbian)
2. Nikezić, D., Marković, P., Bek-Uzarov, D., 1991. Calculation of the calibration coefficient for radon measurements with bare track detector LR 115 II, Submitted for publication to the Health Physics.
3. D.Nikezić., Markovic,P., Bek-Uzarov, D., 1991. Determination of calibration coefficient for radon measurements using LR-115-II track detector in diffusion chamber, Submitted for publication to the Health Physics.

**FACTORS AFFECTING RADON LEVELS
IN HOMES IN BRITISH COLUMBIA, CANADA**

by

D.R. Morley¹, B.G. Phillips¹, C. Van Netten²

1. Province of British Columbia, Ministry of Health, Radiation Protection Services Branch, Suite 200, 307 West Broadway Vancouver, B.C. - V5Y 1P9, CANADA. Fax (604) 660-6663
2. Faculty of Medicine, The University of British Columbia, 5804 Fairview Avenue, Vancouver, B.C. - V6T 1V5, CANADA. Fax (604) 228-4994

ABSTRACT

British Columbia, Canada's most westerly province, has diverse geologic and climatic characteristics, making it a region where predicting radon gas levels is quite complex. Data recently obtained for eleven (11) communities confirm an association between background terrestrial gamma radiation measurements and indoor radon levels in homes. Direct links between radon levels and other factors such as home design/construction features and heating/ventilation systems were observed in data for some communities, but not necessarily from the overall data.

INTRODUCTION

In the mid 1970's, public health concerns about radon in homes began to emerge in Canada. At that time, radon/radon daughter surveys were carried out in homes in two areas of the province, using grab sample techniques (1, 2). The two studies identified widely differing levels, between those for the Vancouver area (which were low) and those in the Castlegar area, which were higher.

With the emergence of improved radon detection devices in the mid 1980's, the B.C. Ministry of Health commenced a program of long-term measurements in homes in a selection of eighteen communities with differing radon potential, to assess the extent of radon as an environmental health risk to the public. Results of radon measurements for eleven communities are presented in this paper, along with an assessment of the association with factors thought to impact the radon levels.

DATA COLLECTION

Communities were selected as a representative sample for the province, based principally upon a variety of geological,

climatic and geographical factors. Volunteers were solicited from each community to permit their homes to be tested for radon. Trained staff from the Ministry placed the radon detectors in appropriate locations in the home and they undertook the completion of survey questionnaire with the occupants, regarding the physical characteristics of the home and some lifestyle information. A minimum of seventy (70) single family dwellings were required for each community to provide a statistically representative sample.

Radon levels were assessed using commercially available alpha track detectors (available from the Barringer, REM and Terradex companies). Two detectors were normally placed in each home for a period of one year. One detector was placed in the lowest living area of the home (e.g. basement) and one in the main living area. Duplicate detectors were placed side by side in a selective number of homes to provide information on the reproducibility of the measurements.

Terrestrial gamma radiation levels were determined using a portable high pressure ionization chamber instrument (Reuter Stokes model RSS-111). At least five (and usually more) separate readings were made in representative locations in each community. Readings were corrected for local cosmic ray contribution, to provide the net terrestrial gamma component.

For each home selected, a questionnaire survey was completed, in which the following information was obtained:

- 1) Building factors - age of home, type of foundation, basement/lower level structure, heating system type and location, and air conditioning use.
- 2) Personal factors - number of persons in the home, occupancy factors, smoking habits, and incidence of cancer.

RESULTS

Table 1 presents a summary of the radon levels measured, for lowest/basement levels and for main floor areas of the home. The mean values for main floor areas ranged from a low of 18 Bq/m³ (0.5 pCi/l) for the Greater Vancouver area to a high of 240 Bq/m³ (6.5 pCi/l) for the City of Castlegar. In the Castlegar sample, approximately 41% of the main floor levels exceeded 150 Bq/m³ (4 pCi/l) while 6% exceeded 750 Bq/m³ (20 pCi/l).

Figure 1 illustrates the correlation between main floor radon levels and the local terrestrial gamma radiation level for each of the eleven communities given in Table 1. A positive correlation was observed, with a coefficient value of 0.66 (p=.04). From figure 1, it appears that more than one trend exists, suggesting that the radon levels may be significantly affected by more than one variable. For Castlegar and Prince George, which have clearly outlying radon values above the general trend (in figure 1), both communities are situated on permeable soil structures.

Table 1 - Radon Measurement Results In Homes
In B.C. Communities

BASEMENT					
Location	# of Homes	Min. (Bq/m ³)	Max. (Bq/m ³)	Mean (Bq/m ³)	Mean Ranking
Castlegar	69	33	1750	390	1
Cranbrook Area	67	15	330	74	9
Kamloops	39	4	280	56	10
Kelowna	76	15	1080	140	5
Nelson	73	33	1490	200	4
Penticton	72	22	1730	260	2
Prince George	74	33	2070	240	3
Quesnel	70	22	570	85	8
Valemount	51	22	550	140	6
Greater Vancouver	-	-	-	-	-
Vernon	74	30	430	130	7

MAIN FLOOR					
Location	# of Homes	Min. (Bq/m ³)	Max. (Bq/m ³)	Mean (Bq/m ³)	Mean Ranking
Castlegar	68	26	1470	240	1
Cranbrook Area	90	7	830	63	8
Kamloops	84	4	160	41	10
Kelowna	77	19	900	85	6
Nelson	74	22	1270	122	3
Penticton	73	15	810	107	4
Prince George	75	26	680	126	2
Quesnel	69	4	250	56	9
Valemount	51	22	260	90	5
Greater Vancouver	135	7	60	18	11
Vernon	75	26	250	78	7

Figure 1

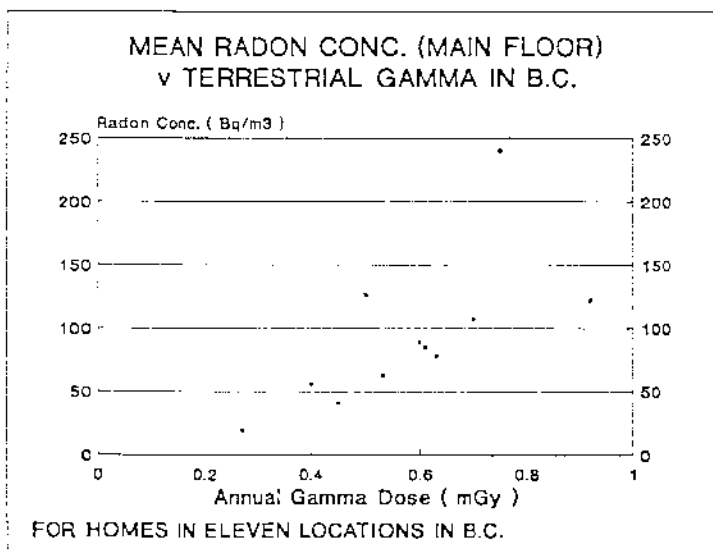

Results from the questionnaire surveys, relating to the building and personal factors, were analyzed for association with radon levels. The general findings are reviewed in the following discussion.

DISCUSSION

Good correlation exists between mean radon levels in a sample of homes and the general terrestrial gamma radiation levels for a community. This is to be expected since elevated terrestrial gamma levels are associated with increased concentrations of uranium and its decay products in surface soils. Radium-226 is the uranium decay product that produces radon.

Although terrestrial gamma measurement has been found to be useful technique for determining which communities may have elevated radon levels, other factors such as soil permeability, moisture content (3) etc. play an important role in radon transportation to affect the concentration in air. Work to date has indicated no correlation between the indoor radon levels in any individual home and the terrestrial gamma level measured at the site.

Building factors were evaluated in relation to radon levels, on a community-by-community basis as well as from the overall (pooled) data. The pooled data indicates that homes with air conditioning were more likely to have lower radon levels, both on the main floor (probability coefficient $p=0.078$) and in the basement/lower level ($p=0.025$). For homes with heating furnaces located in the basement, the main floor radon level was likely to be elevated ($p=0.065$). If uncovered soil areas exist in the lower level, then radon concentrations were likely to be higher ($p=0.059$).

Other building factors were statistically significant within an individual community's data, but were not consistent from community to community.

Such factors include (1) age of the home; (2) type of foundation; (3) type of heating system; (4) separation of lower level (basement) from main floor; and (5) the presence of opening windows in the lower level.

Personal factors did not appear to have any significant association with radon levels, either within individual community data or with the overall data.

NOTE

Data is expected for a further seven (7) communities which were still under test at the time of writing this paper. This additional information will provide valuable guidance on radon levels in British Columbia's more northerly and coastal communities, as well as adding to the overall data base for further analysis.

REFERENCES

1. "Design and Interpretation of Large Surveys for Indoor Exposure to Radon Daughters", E.G. Letourneau, R.G. McGregor and W.B. Walker (Health and Welfare Canada); Radiation Protection Dosimetry. Vol. 7 No.1-4, p.303 - 308.
2. "Background Levels of Radon and Radon Daughters in Homes in the Castlegar - Trail Area of British Columbia", R.G. McGregor (Health and Welfare Canada). Report submitted to the B.C. Ministry of Health, Radiation Protection Service, November 1978.
3. "A Cross Canada Outdoor Radon Survey", R.L. Grasty (Geology Survey of Canada). Paper presented at the 5th International Symposium on the Natural Radiation Environment, Salzburg, Austria, September 22-28, 1991.

MEASUREMENT OF RADON ACTIVITY AT SOME RADIOACTIVE SITES IN INDIA

Jaspal Singh, Lakhwant Singh, Surinder Singh and H.S.Virk,
Department of Physics, Guru Nanak Dev University,
Amritsar-143005, India.

ABSTRACT-

The present study deals with the evaluation of radon levels in some houses at the radioactive sites of Himachal Pradesh, India. In one of the areas under study, the radon activity is found to be 983.60 Bq/m^3 in summer and 1115.04 Bq/m^3 in winter giving an annual exposure dose of 45.94 mSv to the inhabitants. In the second area these levels are found to be 611.92 Bq/m^3 and 685.14 Bq/m^3 , respectively, exposing the people to an annual dose of 28.39 mSv . The life time risk coefficients of lung cancer in these areas are 8.25×10^{-2} and 5.1×10^{-2} respectively.

INTRODUCTION

Almost one half of the natural radiation exposure received by human is from radon and its solid progeny in air⁽¹⁾, which can result in a significant risk to the general public. Until few years back it was considered to be a health hazardous only to the workers engaged in the mining and milling of uranium, but now surveys carried out all over the world⁽²⁻⁴⁾ shows high concentrations of radon in some dwellings that could entail significant health risks.

The daughter products of ^{222}Rn viz; ^{218}Po , ^{214}Pb , ^{214}Bi , ^{214}Po , which are solid under ordinary conditions, attach themselves to atmospheric dust. During inhalation these particles may deposit in the lung and damage the tissue. It is therefore, necessary to monitor levels of radon in places where people are exposed to radon, particularly at sites where the geological formations are enriched with uranium. So we have chosen two sites in radioactive areas-Rameda and Samurkalan in Himachal Pradesh, India.

EXPERIMENTAL TECHNIQUE

Track etch technique (LR-115 Type II) has been used for the measurement of radon activity in the dwellings. Small pieces (1 cm^2) of LR-115 were used to measure the radon activity in winter as well as in summer season. The detailed methodology of the experiment is given elsewhere⁽³⁾. The track density was converted⁽⁵⁾ into the units of Bq/m^3 using a calibration constant assuming an equilibrium factor of 0.5 between radon and its progeny.

RESULTS AND DISCUSSION

Radon measurements have been carried out in 18 houses of Rameda and 19 houses of Samurkalan villages. The choice of dwellings was random and one living room of each dwelling was selected for radon measurement. Tables 1 & 2 give the radon activity recorded in the houses of Rameda for the summer and the winter seasons, respectively. The right, front and left sides to the entrance are designated as wall A, wall B, wall C respectively and the entrance side as wall D. In both of these areas walls and floors have been constructed from local sand stones covered with a paste of mud. The roofs are made of wood. The surveyed houses are not properly ventilated.

WALL TO WALL VARIATION

From the Tables 1 and 2 it is clear that there is a large variation of radon activity from wall to wall in the same room. This variation shows that the members of a family while living in the same room may be exposed to different levels of radon activity depending upon their sitting side or bedside. This variation may be attributed to the fact that certain positions in a room may have more quantity of uranium enriched rock species than to the others and also on the ventilation system of the rooms.

HOUSE TO HOUSE VARIATION

The radon activity in the Rameda area varies from one house to the other as much as 489.14 - 2305.19 Bq/m³ (Table 1) and 542.05 - 1975.98 Bq/m³ (Table 2) during the summer and winter seasons, respectively. It is evident from this fact that the people while living in the adjacent houses at radioactive areas can have different exposures of radon activity.

SEASONAL VARIATIONS

The average radon activity recorded during the summer and winter seasons in the Rameda area is 983.60 Bq/m³ and 1115.04 Bq/m³, respectively. This variation is due to changed ventilation system for the summer and winter seasons. During winter season the houses are made air tight, as a result the ventilation is reduced and hence less mixing with the outdoor air which causes more accumulation of radon and its daughter product activity indoors.

Similar variations are noted in Samurkalan area. The average radon activity recorded in this area is 611.92 Bq/m³ and 685.14 Bq/m³ in the summer and winter seasons, respectively.

LUNG CANCER RISK

The average annual radon activity comes out to be 1049.32 Bq/m³ and 648.53 Bq/m³ in the Rameda and Samurkalan areas

repectively. This much radon activity gives an average annual exposure dose of 45.94 mSv and 28.39 mSv, respectively to the inhabitants of these areas. The life time lung-cancer risk-coefficients for the Rameda and Samurkalan areas⁽⁸⁾ are found to be 8.25×10^{-2} and 5.1×10^{-2} , respectively.

ACKNOWLEDGEMENTS

Jaspal Singh and Lakhwant Singh are thankful to the council of Scientific & Industrial Research (CSIR), New Delhi for providing the financial assistance in the form of senior research fellowship. Thanks are also due to Mr. Santokh Singh for his help in the field work as well as in laboratory analysis. The pepole of Rameda and Samurkalan area are gratefully acknowledged for their allowance to fix our samples in their houses and took care of them.

REFERENCES

1. UNSCEAR. Exposures from Natural Sources of Radiation. United Nations Scientific Committee on the Effects of Atomic Radiation, Report No. A/AC82/R441 (1986).
2. ICRP-50. Lung Cancer Risk from Indoor Exposures to Radon Daughters. Pergamon Press, Oxford, U.K., (1987).
3. Singh, J., Singh, L., Ramola, R.C., Singh, M., Singh, S. and Virk, H.S. Radon Pollution Studies in the Environs of Radioactive Areas by Using Solid State Nuclear Track Detectors. Nucl.Geophys. 3 (4) 297-298 (1989).
4. NRPB. Documents of National Radiation Protection Board, U.K. 1 (1) (1990).
5. Suba Ramu, Muraleedharan, T.S. and Ramachandran, T.V. Calibration of Solid State Nuclear Track Detector for the Measurment of Indoor Levels of Radon and its Daughters. Sci. Total Envir. 73, 245-255 (1988).
6. Cross, F.T., Harley, N.H., Hoffman, W. Health Effects and Risks from Rn-222 in Drinking Water. Health.Phys., 48 (5),649-670 (1985).

Table 1. Radon activity (Bq/m^3) recorded in the village Rameda (H.P., India) during the summer season and the annual dose delivered to the inhabitants (mSv).

House code	Radon Activity (Bq/m^3)				Average	Annual Dose (mSv)
	Wall A	Wall B	Wall C	Wall D		
R-1	0854.70	0535.39	0962.74	0507.64	0715.11	31.31
R-2	0617.16	0646.39	0579.79	0560.92	0601.06	26.31
R-3	1167.35	1524.40	1136.27	0943.13	1192.78	52.22
R-4	0819.92	0699.67	1121.47	0731.86	0843.23	36.91
R-5	2033.52	2023.90	2402.78	2760.57	2305.19	100.93
R-6	0849.15	1137.38	0635.66	0738.15	0840.08	36.78
R-7	1660.56	0995.30	1148.85	1089.65	1223.94	53.58
R-8	0947.94	0784.03	0936.10	0827.69	0873.94	38.26
R-9	0804.01	1055.98	0655.64	0624.93	0785.14	34.37
R-10	1356.42	-	1489.99	1545.49	1463.96	64.09
R-11	0868.02	0807.71	0763.68	-	0813.13	35.60
R-12	0363.34	0422.17	0913.16	0512.82	0552.87	24.20
R-13	0475.45	0416.62	0492.84	0571.65	0489.14	21.41
R-14	1068.19	0907.98	1109.24	0595.70	0920.28	40.29
R-15	1292.41	-	1282.42	0806.60	1127.14	49.35
R-16	1041.55	0888.00	0934.62	0630.48	0873.66	38.25
R-17	1673.51	1476.67	1216.93	0641.95	1252.26	54.82
R-18	0659.71	0790.32	0875.79	0563.51	0722.33	31.62
Overall mean value					0983.60	43.06

Table 2 Radon activity (Bq/m^3) recorded in the village Rameda (H.P., India) during the winter season and the annual dose delivered to the inhabitants (mSv).

House code	Radon Activity (Bq/m^3)				Average	Annual Dose (mSv)
	Wall A	Wall B	Wall C	Wall D		
R-1	1031.56	0835.83	1341.62	0741.85	0987.71	43.24
R-2	0593.33	0657.86	0937.58	0449.55	0660.08	28.90
R-3	0879.86	1329.41	-	0719.65	0976.30	42.74
R-4	1134.79	0762.57	-	0860.25	0919.20	40.24
R-5	1700.15	1893.29	2079.40	2231.10	1975.98	86.51
R-6	1217.67	-	1138.12	0907.24	1087.67	47.62
R-7	2182.63	1086.69	1498.50	1389.35	1539.29	67.39
R-8	1334.59	1058.94	1176.23	1045.25	1153.75	50.51
R-9	1014.17	1445.22	1065.97	1355.31	1220.16	53.42
R-10	1542.53	-	1417.47	1495.54	1485.18	65.02
R-11	1234.32	1283.16	1210.64	1307.21	1258.83	55.11
R-12	0535.76	0676.37	0612.72	0618.27	0610.78	26.74
R-13	0543.90	0563.88	0510.97	0549.45	0542.05	23.73
R-14	0833.61	0544.27	1366.78	0445.48	0797.53	34.91
R-15	1438.19	-	1100.38	1576.20	1371.59	60.05
R-16	0828.06	0950.53	1189.92	0847.67	0954.04	41.77
R-17	1531.06	1325.71	1482.96	-	1446.57	63.33
R-18	1064.86	1134.79	1201.02	0975.69	1094.09	47.90
Overall mean value					1115.04	48.82

DETECTION OF RADON AND RADON DAUGHTERS BY MEANS OF AN ELECTRET IONIZATION CHAMBER COMBINED WITH SOLID STATE NUCLEAR TRACK DETECTORS

B. Dörschel¹⁾, B. Burgkhardt²⁾, S. Kunzmann¹⁾, J. Lewitz¹⁾,
E. Piesch²⁾, H. Seifert¹⁾, G. Streubel¹⁾

1) Dresden University of Technology, Institute of Radiation Protection Physics,
Dresden, FRG

2) Karlsruhe Nuclear Research Centre, Health Physics Division, Karlsruhe, FRG

ABSTRACT

For measuring radon concentrations in air an electret ionization chamber of the diffusion type was developed. The change of the charge density on the electret surface is a measure of the radon concentration from which the concentration of radon daughters can be estimated assuming an equilibrium factor. This factor, however, varies strongly dependent on environmental and other conditions. In order to determine the equilibrium factor more precisely, a combination of three solid state nuclear track detectors was studied which allows the selective detection of alpha particles in defined energy intervals.

INTRODUCTION

The radiation exposure of the human respiratory tract is mainly determined by the concentration of short-lived radon decay products in the inhaled air. Using passive detectors inside diffusion chambers the radon concentration in air can be measured from which the concentration of radon daughters is calculated presuming an appropriate equilibrium factor^{1,2}. Because the equilibrium factor is not known with the required precision, the uncertainty of the estimated radiation exposure is relatively high³. The use of a multi-detector system is, therefore, proposed which allows to measure the radon concentration using an electret ionization chamber and separately the equilibrium factor using three solid state nuclear track detectors.

RADON DETECTION BY MEANS OF AN ELECTRET IONIZATION CHAMBER

The principle of an electret ionization chamber (EIC) of the diffusion type is shown in Figure 1. On the top of the diffusion chamber aerosols and radon daughters are retained on the diffusion filter whereas the radon gas diffuses into the chamber volume. Radon decay products generated within the EIC are almost completely plated-out on the inner surface of the chamber walls. The electret made of PTFE or FEP is characterized by a quasi-permanent electrical charge which generates a surface potential, the electret voltage U_E . Within the chamber alpha particles emitted by radon and its daughters result in an ionization of the air and thus in a degradation of the electrical charge of the electret surface.

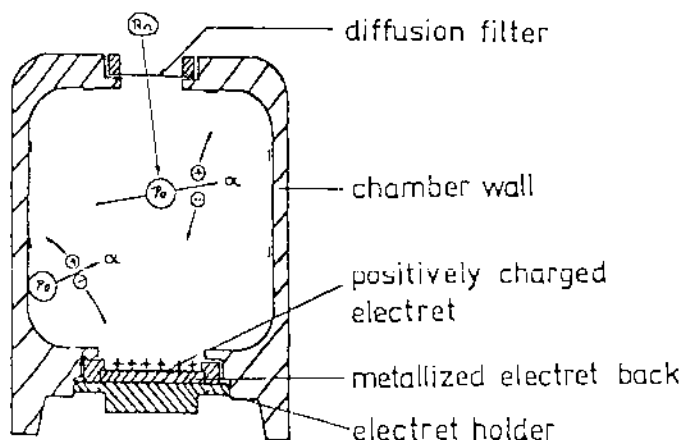

Figure 1 Scheme of the electret ionization chamber for radon measurements⁴

The response of the EIC is given by

$$m_{Rn} = \frac{\Delta U_E}{c_{Rn} \Delta t} \quad (1)$$

where ΔU_E is the radiation induced change of the electret voltage, whereas c_{Rn} and Δt are the concentration of ^{222}Rn and the exposure period, respectively. The response m_{Rn} was calculated by means of a Monte Carlo program⁵ resulting in $m_{Rn,calc} = 0.065 \text{ V/Bq}\cdot\text{m}^{-3}\cdot\text{d}$. By exposing the EIC in different well-defined radon atmospheres, the experimental estimation resulted in a value of $(0.060 \pm 0.004) \text{ V/Bq}\cdot\text{m}^{-3}\cdot\text{d}$. The lower detection limit was found to be $40 \text{ Bq}\cdot\text{m}^{-3}$ (with $\Delta t = 7\text{d}$) and the upper limit $5 \text{ kBq}\cdot\text{m}^{-3}$ (with $\Delta t = 1\text{d}$).

DETECTION OF RADON AND RADON DAUGHTERS USING A SYSTEM OF NUCLEAR TRACK DETECTORS

It is the common technique to measure the radon concentration using, for instance, EIC or other types of diffusion chambers. For the estimation of the lung exposure by radon decay products, however, the equilibrium factor is needed. Because this factor varies strongly with a number of environmental and other conditions, a consistent system of three nuclear track detectors has been studied with the aim of a separate detection of radon and its daughters under free air conditions. Thus, the equilibrium factor can be determined as average value also for longer exposure periods.

The physical basis of such a detector system is formed by the creation of different energy response functions for the three detectors as the result of a suitable combination of the detector and absorber material and/or an optimization of the etching procedure. For this purpose the electrochemical etching technique of polycarbonate detectors (MAKROFOL DE, Bayer Leverkusen, FRG) and CR-39 detectors (PATRAS, Optische Werke Rathenow, FRG) have been studied.

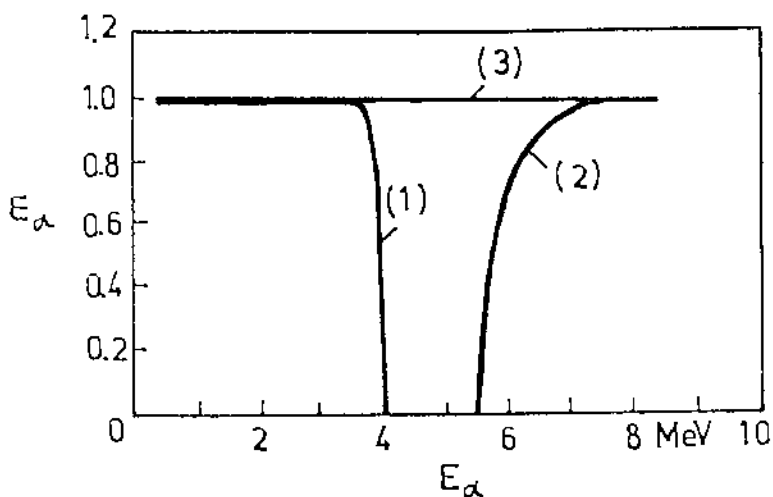

Figure 2 Qualitative presentation of the track detection efficiency ϵ_{α} of the nuclear track detector system as a function of alpha energy E_{α}

- (1) MAKROFOL (electrochemically etched: 80 vol% 6N KOH + 20 vol% ethanol, 35°C, 5h 100Hz and 1h 2kHz, 26.7kV/cm)
- (2) CR-39/PATRAS (chemically pre-etched: 6N KOH, 60°C, 10h; electrochemically etched: 6N KOH, 60°C, 2h 2kHz, 15kV/cm)
- (3) CR-39/PATRAS (electrochemically etched: 6N KOH, 60°C, 5h 2kHz, 15kV/cm)

From Figure 2 follows that the MAKROFOL DE detector (1) has an upper energy threshold of about 4 MeV⁶. Using this etching condition, the detector registers only alpha particles from ²²²Rn and its decay products incident from an air layer in a certain distance of the detector. On the other hand, decay products plated-out on the detector surface do not contribute to the track density because the corresponding alpha particle energies of about 6 MeV exceed the upper energy threshold. The resulting track density of the detector (1) is thus given by

$$\rho_1 = m_1^{Rn} \cdot c_{Rn} + m_1^{DA} \cdot c_{DA} \quad (2)$$

where m_1^{Rn} and m_1^{DA} are the detector responses to ²²²Rn and radon daughters in air, respectively, and c_{Rn} and c_{DA} the corresponding activity concentrations in air.

The second detector of the system should have a lower energy threshold at about 5.5 MeV, in order to detect only decay products from a certain air layer in front of the detector as well as decay products plated-out on the detector surface, whereas alpha particles from ²²²Rn are not registered. The track density of the detector (2) follows from

$$\rho_2 = m_2^{DA} \cdot c_{DA} + m_2^{DD} \cdot c_{DD} \quad (3)$$

Here, m_2^{DD} is the detector response to daughters deposited on the detector surface and c_{DD} the corresponding activity concentration. The lower energy threshold of 5.5 MeV could be created by means of a suitable dimensioned absorber in front of the detector. Using CR-39/PATRAS, however, this threshold has been obtained by chemical pre-etching of the detectors for 10 hours (see Figure 2).

Finally, a third detector (3) without an energy threshold is needed. Then its track density follows from

$$\rho_3 = m_3^{Rn} \cdot c_{Rn} + m_3^{DA} \cdot c_{DA} + m_3^{DD} \cdot c_{DD} \quad (4)$$

Studies with CR-39/PATRAS detectors showed that without applying a chemical pre-etching this non-threshold behaviour exists (see Figure 2).

Thus, from equations (2), (3) and (4) the concentration of ^{222}Rn and its daughters in air can be determined separately whereas the plate-out effect on the detector surface is eliminated.

CONCLUSIONS

Using the track etched detector system described here, an energy-selective detection of alpha particles emitted by radon and its daughters is possible. From these results a mean equilibrium factor follows which can be used for the interpretation of the results of radon measurements using EIC or other types of passive radon diffusion chambers.

REFERENCES

- (1) Urban, M. and Piesch, E., 1981, Low Level Environmental Radon Dosimetry with a Passive Track Etch Device, *Rad. Prot. Dosim.*, 1, pp. 97-110
- (2) Frank, A.L., et al., 1973, A Diffusion Chamber Radon Dosimeter for Use in Mine Environment, *Nucl. Instr. Meth.*, 109, pp. 537-539
- (3) Urban, M., et al., 1985, Bestimmung der Strahlenbelastung der Bevölkerung durch Radon und dessen kurzlebige Zerfallsprodukte in Wohnhäusern und im Freien, KfK 3805
- (4) Seifert, H., Kunzmann, S. and Dörschel, B., 1991, Development of an Electret Ionization Chamber (EIC) for Measurement of Radon-222 in Air, Paper held at 23rd Int. Symp. Radiation Protection Physics, Gaussig, FRG
- (5) Kunzmann, S., 1991, Entwicklung einer Elektret-Ionisationskammer zur Messung der Radon-Aktivitätskonzentration in Luft, Diplomarbeit, TU Dresden, FRG
- (6) Jozefowicz, K. and Piesch, E., 1990, Electrochemically etched Makrofol DE as a Detector for Neutron Induced Recoils and Alpha Particles, *Rad. Prot. Dosim.*, 34, pp. 25-28

MEASUREMENTS OF RADON CONCENTRATIONS IN BUILDINGS - RESULTS OF INVESTIGATIONS IN MINING REGIONS OF SAXONY AND THURINGIA

R.Czarwinski, R.Lehmann, W.Röhnsch
Federal Office for Radiation Protection, F.R.G.

ABSTRACT

In the East German Federal States Saxony and Thuringia territories exist where rock formations with silver and cobalt ores and above-average uranium content are located and intensive mining has taken place. In these regions a series of measurements of radon concentrations in buildings is carried out to determine local mean values, local ranges and buildings with very high concentrations of radon.

INTRODUCTION

The radiological situation in certain regions of Saxony and Thuringia is characterized by above-average uranium concentrations in layers close to the surface and, in addition, by the mining influence. The local higher uranium concentrations determined by airborne gamma-ray spectrometry are shown in Figure 1.

By order of the Federal Minister for Environment, Nature Conservation and Nuclear Safety the "Project for the Registration, Investigation and Radiological Evaluation of the Mining Residues" has to be implemented by the Federal Office for Radiation Protection. The investigation of radon concentrations in buildings with the aim to estimate regional and local distribution patterns of radon concentrations as well as the identification of houses with very high concentrations and their reasons are essential parts of this project. Since November 1990, investigations have been carried out in houses located in mining regions with a high density of measuring points.

For the assessment of the results additional measurements are carried out in regions not influenced by mining, e.g. in the Fichtel Gebirge, in regions of Lusatian granite, in the Norddeutsche Tiefebene etc..

METHODOLOGY OF MEASUREMENTS

To get a rapid survey of the radiological situation, short-term measurements (screening measurements) with activated charcoal detectors analyzed by liquid scintillation counting are carried out. The exposure of the charcoal takes 24 hours under unfavourable ventilation conditions, i.e. closed doors and windows.

Dwellings, factories, schools, kindergarten and other buildings are investigated. Participation in measurements is optional and free of charge.

Results are compared with the recommendation of the German Radiation Protection Commission (Strahlenschutzkommission - SSK) who defined a "normal range" of the radon concentration in living rooms of Germany up to 250 Bq/m^3 .

If the radon concentration measured by the screening method in lounges and living rooms is evidently higher than 250 Bq/m^3 it is probable that the annual mean value exceeds this limit, too; the higher the level is exceeded the greater this probability. Therefore, in addition to the verification of short-term results long-term investigations are necessary to establish remedial measures. For these long-term measurements already started diffusion chambers with track etch detectors are used. Each citizen/institution involved in the measurements is informed about the results of the measurements and an assessment as demonstrated in Table 1 is given. The investigations will be extended to measurements in up to 100,000 buildings in about 200 communities.

RESULTS AND CONCLUSIONS

The results of the investigations hitherto achieved show that there is a strong correlation between radon concentration in houses and geological subsoil. A relatively great number of houses with above-average radon concentration has been found in granite and certain Zechstein subdivision regions whereas buildings above glacial sediments have much lower concentrations. Figure 2 presents the results of measurements in different regions without any mining influence.

Figure 3 shows the results of screening measurements in about 15,000 buildings in regions where uranium mining and milling as well as former ore mining has taken place. In general, there is no striking difference in the frequency distribution compared with regions of similar geology. Only in cases where geological and mining influences are overlapping extreme values of the radon concentration in houses have been observed. An outstanding example is the old mining town Schneeberg where radon concentrations up to more than $100,000 \text{ Bq/m}^3$ have been measured by the screening procedure (see Table 2).

An influence of mining and milling residues on the radon concentration in buildings can be attributed to

- building on waste rocks
- use of waste rocks for building purposes
- shallow drivings partly immediately under, or nearby, or connected with houses
- building over of outcroppings of geological disturbances and ore-bearing lodes.

Moreover, the investigations have indicated that the underground ventilation has a great influence on the radon concentration in houses constructed on shallow drivings.

At Schlemma, a centre of recent uranium mining, the mining facilities like ventilation installations are still in operation.

First experiments show that the radiological situation changes dramatically if the mining exhausters are switched off. An increase of the radon concentration two orders of magnitude higher can be observed in certain buildings after the ventilation has been stopped (see Figure 4). In this special case, it cannot be excluded that the results of screening measurements do not necessarily represent pessimistic information about the radiological situation.

Tab 1: Follow-up of the radon screening measurements in dwellings

Exposure of charcoal detectors under conditions of closed doors and windows over 24 hours					
C_{Rn} (Bq/m ³)	\leq LDL	$>$ LDL \leq 250	$>$ LDL \leq 250 cellar \geq 2,000	$>$ 250 \leq 1,000	$>$ 1,000
valuation	C_{Rn} possible handling faults	C_{Rn} within the ordinary natural range	C_{Rn} within the ordinary natural range	C_{Rn} possibly above the ordinary natural range	C_{Rn} possibly considerable above the ordinary natural range
recommended measures	control measurements	no measures of control or radon-mitigation	as a precaution long-term-measurements of C_{Rn} in a room directly situated above the cellar	verification by long-term-measurements; radon-mitigation with simple methods during the next years	methodical verification of measured C_{Rn} , reconnaissance of radon-sources, mitigation measures
Explanations LDL: lower detection limit C_{Rn} : radon concentration					

Tab.2: Frequency of radon concentrations <250 Bq/m³ in selected communities measured by screening method

Characterization of measured location	Geological remarks	EXAMPLE		
		community	relative frequency in % (< 250 Bq/m ³)	maximum concentration (Bq/m ³)
mainly old mining	contact area to granite	Schneeberg	48	115 000
uranium mining	carbon schist, diabases, phyllites, quartzitic rocks	Schlema	76	21 000
uranium mining	ochrons lime, diabases, clay schist	Ronneburg	85	3 100
uranium milling	lower permian	Crossen	76	2 300
without mining and milling	Fichtel Gebirge granite	Bad Brambach	25	8 700
without mining and milling	Erz Gebirge granite	Stangengrün	13	18 000
without mining and milling	Lusatian granite (glacially covered over)	Amsdorf-Hilbersdorf	79	1 600
without mining and milling	glacial sediments (North German Lowland)	Körchow / Zühr	94	470

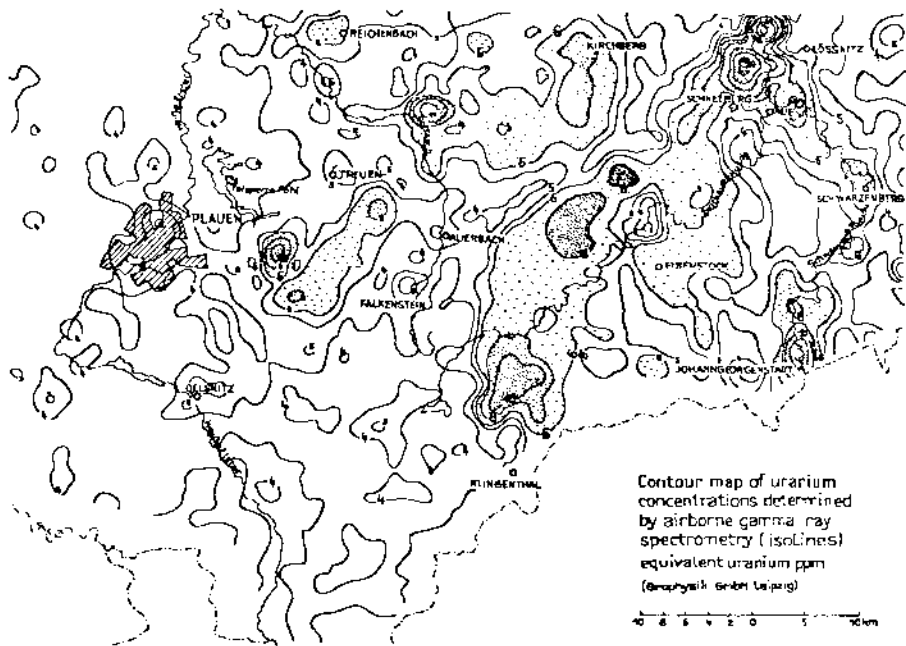

Fig.1: Aerogamma map of Westerzgebirge

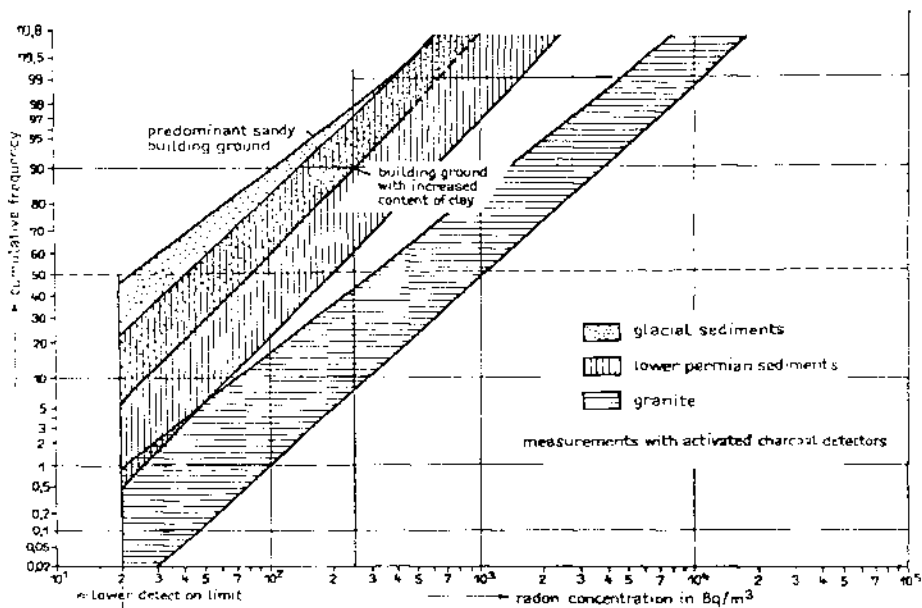

Fig.2: Radon concentration in dwellings located in special regions of Erzgebirge and Norddeutsche Tiefebene

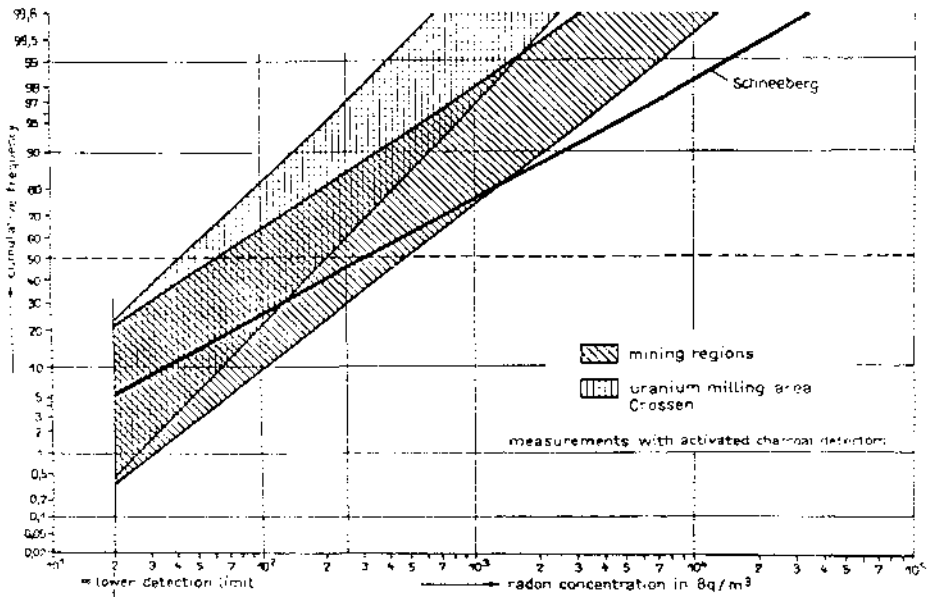

Fig.3: Radon concentration in dwellings located in mining regions of Westerzgebirge

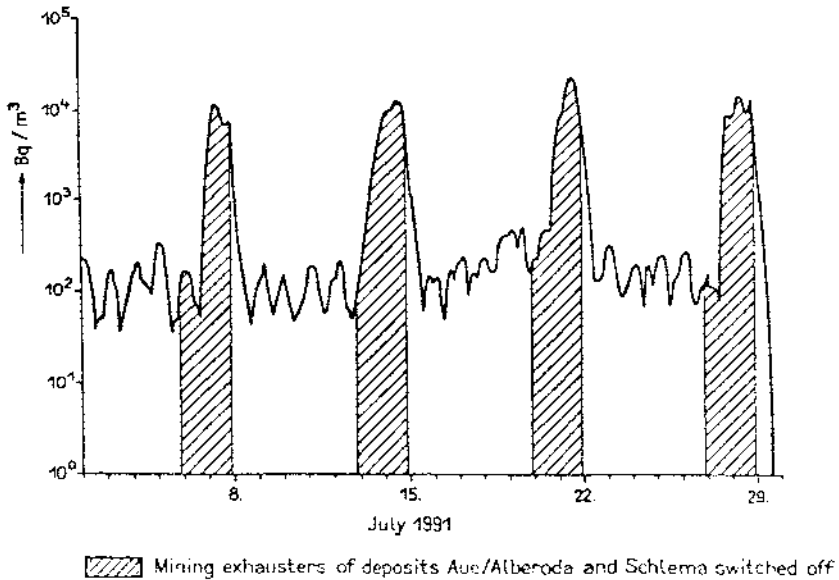

Fig.4: Radon concentration in a building depending on ventilation in shallow drivings

CLEANERS IN REDUCING THE HAZARDS OF INDOOR RADON DECAY PRODUCTS

N. Montassier, P.K. Hopke, Y. Shi and P. Wasiolek
Department of Chemistry, Clarkson University, Potsdam,
N.Y., 13699-5810, USA

and B. McCallum
Atomic Energy of Canada, Ltd, Ottawa, Ontario, Canada

ABSTRACT

The objective of this study was to evaluate the influence of three types of air cleaner on the concentration and size distribution of radon progeny in a normally occupied house. Using an automated, semi-continuous, graded-screen array system and a radon monitor, the activity size distribution and radon concentration was measured and the exposure of the occupants of the home to radon could be assessed. The dose model developed as part of the recently released U.S. National Academy of Sciences report was used to relate the exposure to deposited dose in the tissue of the bronchial epithelium. Thus, the effectiveness of the air cleaners in reducing both exposure and dose were evaluated.

INTRODUCTION

A critical factor for the effectiveness of radon decay products in providing dose to the human respiratory tract is the size of the particle to which the decay product is attached. Air cleaners can effectively remove most particles and radon decay products from indoor air. The removal of the particles results in the increase of the "unattached" fraction, that can deposit more effectively its dose of radiation to the lung tissue. In fact, the increased dose per unit exposure means that the dose reduction will be lower than the reduction of the radioactive concentration. Thus, the exact dose impacts of air cleaners are uncertain, and studies are needed to measure the concentration and size distributions of the radon progeny activities in real living conditions where air cleaners are being employed.

HOUSE CHARACTERISTICS AND INSTRUMENTATIONS

Experimental data used in this study were collected in a one-story, ranch home in Arnprior, Ontario. This house has a basement with an approximate area of 200m² while the first floor has an area of about 210m². The house was occupied by three people none of whom smoke. Measurements were made from May to July 1991. No heating or air conditioning was used during this period. The sampler and air cleaner were placed at the dining room end of the kitchen/dining area (23m²).

Three types of air cleaner were investigated, a ionization, filtration and air circulation system (NO-RAD), an Electronic Air Cleaner (EAC) with fan, and a multi-stage filter with fan (Pureflow).

Measurements of radon progeny size distributions were made using the Automatic Semi-Continuous Graded Screen Array (ASC-GSA) described in detail by Ramamurthi and Hopke (1991). The ASC-GSA system is a fully automatic device capable of measuring the activity-weighted size distribution of each individual short-lived radon decay product. It uses wire screens for particle segregation and alpha spectrometry for alpha particle detection. The measurements were made over a week long period with alternatively no air cleaner and air cleaner running (Table 1).

Exp.	Sampling period	Number of samples	Conditions
------	-----------------	-------------------	------------

1	May 13-21	77	Background
2	May 21-28	50	NO-RAD on
3	May 28-June 3	54	Background
4	June 3-10	77	EAC on
5	June 10-17	69	Background
6	June 30-July 5	52	Pureflow on
7	July 5-6	11	Background

Table 1: Experiments conditions

Continuous measurements of radon gas were done using a passive radon detector.

RESULT AND DISCUSSION

Mean values plus standard deviation of radon concentration, PAEC and equilibrium factor are presented in Table 2. As expected, radon concentration was not affected by the air cleaners and the values were almost the same for every experiment with a mean of 1.1pCi/l (41 Bqm⁻³). However, we observed a reduction of PAEC and a significant decrease of the equilibrium factor when the air cleaners were running.

Exp.	Mean pCi/l	Radon std	Mean mWL	PAEC std	Equilibrium mean	factor std
1	1.2	0.5	5.8	2.0	0.50	0.13
2	0.8	0.5	2.2	1.1	0.31	0.14
3	0.7	0.4	2.6	2.0	0.41	0.22
4	1.1	0.6	2.1	1.6	0.18	0.12
5	1.7	1.2	7.5	6.2	0.43	0.19
6	1.1	0.7	1.6	1.1	0.15	0.08
7	1.1	0.4	5.0	2.1	0.45	0.13

Table 2: Measurements summary

From the equilibrium factor, one can observe that at fixed radon concentration, the NO-RAD reduced the mean PAEC by 38% while the EAC provided 56% and the Pureflow 65% of reduction.

Changes in size distributions (Fig.1) of the radon progeny as well as PAEC was also observed when the air cleaners were working. A peak in the size range of 1.5 to 5nm was induced when the NO-RAD was running. The EAC caused an increase in the activity fraction of the small particles with a distinct peak in the smallest particle size. Meanwhile, the activity fraction of particles greater than 15nm decreased. The Pureflow system did not seem to change the shape of the size distribution significantly. Those differences can be due

to the way air cleaners remove particles. With its HEPA filter, the Pureflow system eliminate particles of all sizes with almost the same efficiency. This is not the case for the other devices whose removal mechanism can have a greater effect on the largest particles.

Knowing the PAEC concentration and its activity fraction, the annual average exposure E_p and the dose to the bronchial epithelium can be calculated (Table 3). An occupancy factor of 0.68 (ICRP, 1987) was used to estimate E_p . The dose per unit exposure, for a male adult at a mean breathing rate of 0.74 m³h⁻¹, was calculated using the most recent dosimetric model (NRC, 1991 model modified by James et al., 1991). In the current model the dose to basal and secretory cells is evaluated taking account of the calculated deposition of activity as a function of particle size and breathing rate. As expected, the dose per unit exposure (D/E_p) was similar for the "backgrounds" (between 31 and 36 mGy/WLM). For the Pureflow the dose per unit exposure stayed at the same level;

however this value increased to 44mGy/WLM for the NO-RAD and up to 48mGy/WLM for the EAC. This implies that the reduction of exposure by both the NO-RAD and the EAC was much higher than the dose reduction. In fact, comparing the experiments

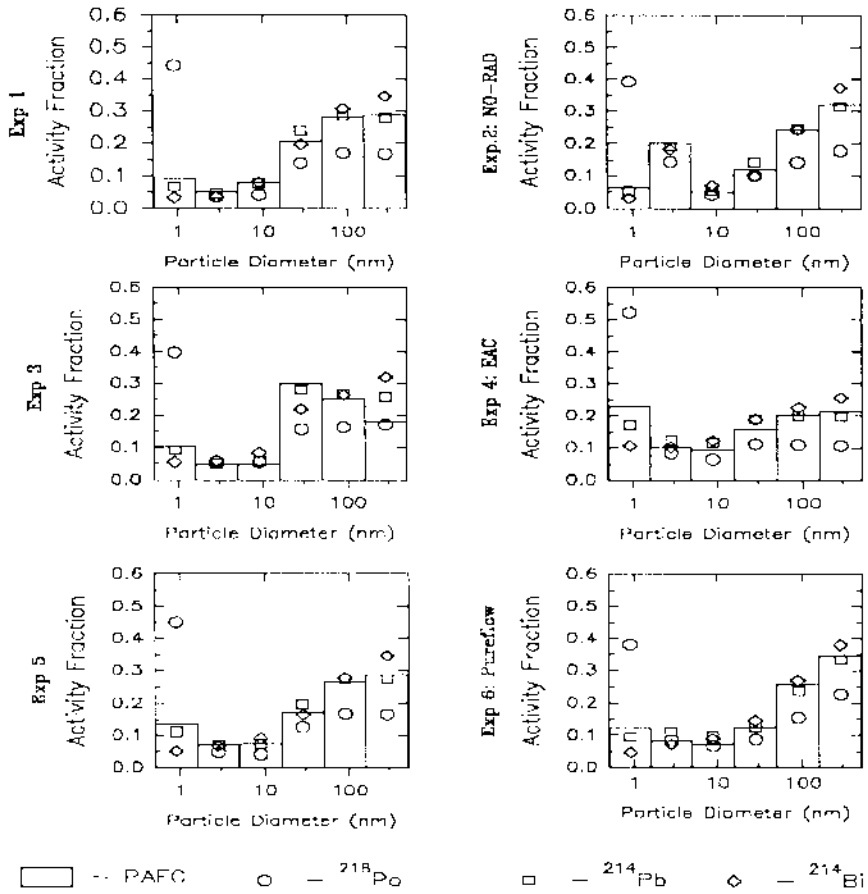

Figure 1: Size distributions

2, 3 and 4 when air cleaners were running with the experiments 1, 3 and 7 respectively, one finds that the exposure reduction per unit radon was 47% for the NO-RAD while the reduction of the doses per unit radon were 27%. The EAC diminished the exposure by 50% and the dose by 33%. A decrease of 67% was observed on both exposure and dose, for the Pureflow system.

Exp.	E_p WLM/y	E_p/Rn WLM/ypCi	Secretory D/E_p mGy/WLM	Cells D/Rn	Basal D/E_p mGy/WLM	Cells D/Rn
1	0.20	0.17	33	5.6	16	2.6
2	0.08	0.09	44	4.1	20	1.9
3	0.09	0.14	34	4.6	16	2.2
4	0.07	0.07	48	3.1	22	1.5
5	0.26	0.15	36	5.6	17	2.6
6	0.06	0.05	35	1.8	16	0.9
7	0.17	0.16	31	4.9	15	2.3

Table 3: Dose exposure

SUMMARY

The effect of three types of air cleaner installed in a single family house in Arnprior, Ottawa, was investigated in

a series of measurements. Each device decreased the concentration of the decay products and reduced the equilibrium factor as well as the exposure. On the other hand, air cleaners producing a shift of the size distribution towards smaller particles, where the dose rate per unit exposure are substantially larger, induce a much lower reduction on the dose. Thus, dose impact of air cleaners depends strongly on the way particles are removed.

REFERENCES

International Commission on Radiological Protection (ICRP). (1987). "Lung cancer risk from indoor exposures to radon daughters." ICRP Publ. 50, Ann. of ICRP, Pergamon, Oxford.

James, A.C., Fisher, D.R., Hui, T.E., Cross F.T., Durham, J.S., Gehr, P., Egan, M.J., Nixon, W., Swift, D.L. and Hopke, P.K. (1991). "Dosimetry of radon progeny." In: Pacific Northwest Laboratory Annual Report for 1990 to the DOE Office of Energy Research, Pt. 1, pp 55-63. PNL-7600, Pacific Northwest Laboratory, Richland, Washington.

National research Council (NRC). (1991). "Comparative dosimetry of radon in mines and homes." National Academy Press, Washington, DC.

Ramamurthi, M. and Hopke, P.K. (1991). "An automated, semi-continuous system for measuring indoor radon progeny activity-weighted size distributions, d_p : 0.5-500nm." Aerosol Sci. Technol. 14: 82-92.

HIGH-ALTITUDE COSMIC RAY NEUTRONS:
PROBABLE SOURCE FOR THE HIGH-ENERGY PROTONS OF
THE EARTH'S RADIATION BELTS

Ferenc Hajnal* and John Wilson**

* US DOE, Environmental Measurements Laboratory, New York, NY, USA

** NASA Langley Research Center, Hampton, VA, USA

Several High-altitude cosmic-ray neutron measurements were performed by the NASA Ames Laboratory in the mid-to late-1970's using airplanes flying at about 13km altitude along constant geomagnetic latitudes of 20, 44 and 51 degrees north. Bonner spheres and manganese, gold and aluminium foils were used in the measurements. In addition, large moderated BF-3 counters served as normalizing instruments.

Data analyses performed at that time did not provide complete and unambiguous spectral information and field intensities. Recently, using our new unfolding methods and codes, and Bonner-sphere response function extensions for higher energies, "new" neutron spectral intensities were obtained, which show progressive hardening of neutron spectra as a function of increasing geomagnetic latitude, with substantial increases in the energy region from 10 MeV to 10 GeV.

For example, we found that the total neutron fluences at 20 and 51 degrees magnetic north are in the ratio of 1 to 5.2 and the 10 MeV to 10 GeV fluence ratio is 1 to 18.

The magnitude of these ratios is quite remarkable. From the new results, the derived absolute neutron energy distribution is of the correct strength and shape for the albedo neutrons to be the main source of the high-energy protons trapped in the Earth's inner radiation belt. In addition, the results, depending on the extrapolation scheme used, indicate that the neutron dose equivalent rate may be as high as 0.1 mSv/h near the geomagnetic north pole and thus a significant contributor to the radiation exposures of pilots, flight attendants and the general public.

RADON IN SHOW CAVES, VISITOR MINES, AND SPAS OF NORTHRHINE-WESTPHALIA

A. Rox and W. Herzog

Staatliches Materialprüfungsamt
Nordrhein-Westfalen
Marsbruchstraße 186
D-4600 Dortmund 41, FRG

ABSTRACT

Radon levels were measured in all show caves, visitor mines and thermal spas of Northrhine-Westphalia. Long-term measurements were performed by a passive time-integrating method using diffusion type dosimeter with nuclear track detector. Radon-222 concentrations up to 12000 Bq m⁻³ were found. Instantaneous measurements of Rn-222 were taken with Lucascells and a portable radon monitor. Decay products were determined via dust filter sampling followed by alpha spectrometry. Equilibrium factors ranged between 0.34 and 0.80.

INTRODUCTION

It is well recognized that the major contribution to the annual average dose received by man has its origin in natural radiation. About half of the effective dose equivalent is due to inhalation of radon and its decay products. Whereas radon concentrations have been measured continuously in almost all West-German coal mines for over 10 years now¹, there has been a lack of such data concerning the visitor mines, show caves and thermal spas where the annual effective dose equivalent may exceed the governmental limits for occupational radiation exposure.

METHODS AND INSTRUMENTS

For long-term Rn-222 determination diffusion cells of the so-called Karlsruhe-type have been used, equipped with cellulose nitrate nuclear track detectors (KODAK, type LR 115 II). The cells were protected against dust and humidity by silicone coated glass fiber filters. 5 to 10 dosimeters were installed along the visitors pathway in each cave or mine. Exposure time ranged from 60 to 90 days depending on radon concentrations. After etching the detectors were analyzed by automatic microscopic image analysis.

Instantaneous radon concentrations were measured using a radon monitor (Atmos-12 by ALNOR) with ionization chamber and/or with Lucas cells of 100 ml volume. Radon daughter products have been accumulated on membrane filters and determined by alpha spectrometry using a portable surface barrier detector spectrometer.

RESULTS

Table 1 contains the maxima, minima and mean values of all measurements, the equilibrium factors F, and the resulting annual effective equivalent doses. In cases where the radon progeny had not been measured an equilibrium factor of 50 % has been assumed. The effective equivalent doses have been calculated according to the following equation and assumptions:

$$D = A \cdot V \cdot t \cdot F \cdot C_D / \text{mSv a}^{-1}$$

A: activity concentration / Bq m^{-3}

V: breathing rate / $1,2 \text{ m}^3 \text{ h}^{-1}$

t: annual working time / 1600 h

F: equilibrium factor

C_D : dose conversion factor / $1,25 \cdot 10^{-9} \text{ mSv Bq}^{-1}$ *)

Some of the annual effective equivalent doses are close to or above the annual limit of 50 mSv for occupational radiation exposure. In these cases it was necessary to reduce the individual working time.

In Fig. 1 the frequency distribution of the radon concentrations in the show caves and visitor mines is shown. Five percent of all values are above 5000 Bq m^{-3} . Fig. 2 shows the radon concentration over time for one cave, exhibiting a distinct minimum during the winter season.

REFERENCES

1. Rox, A., Fahland, J., Freder, R., Herzog, W., 1991, Bestimmung von Radon und seinen Folgeprodukten im Steinkohlebergbau, publication series Progress in Radiation Protection, FS-91-56-T, p. 57-73, ISSN 1013-4506

*) According to the German "Strahlenschutzverordnung"

Acknowledgments

The authors gratefully acknowledge the cooperation and help of the mining authorities of Northrhine-Westphalia and financial support by the Ministerium für Wirtschaft, Mittelstand und Technologie des Landes NRW.

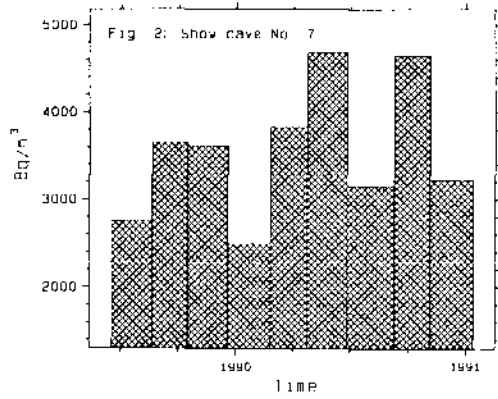
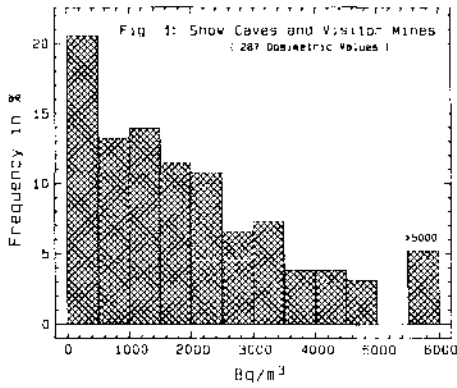

Table 1:

No.	Lucas Cell (Bq/m ³)			Dosemeter (Bq/m ³)			F (%)	mSv/a
	Minimum	Maximum	Mean	Minimum	Maximum	Mean		
1	239	2030	687	114	2916	1153	51.0	14.1
2	1698	3341	2431	144	2616	1197	39.4	11.3
3	38	74	56	46	46	46	47.5	0.5
4	1788	8677	4342	382	4106	1748	44.1	18.5
5	80	508	213	180	359	254	53.5	3.3
6	322	531	452	327	2086	1133	50.0 *	13.6
7	3791	5861	4815	1698	4779	3145	53.1	40.1
8	475	1431	957	59	489	203	65.9	3.2
9	941	5066	2330	907	3916	2307	58.5	32.4
10	630	4929	2730	2337	5359	3521	40.9	34.6
11	65	12398	3953	2820	8822	6697	60.6	97.5
12	99	100	100	81	81	81	33.6	0.7
13	80	635	162	155	1583	907	69.9	15.2
14	192	504	384	2757	3162	3018	50.0 *	36.2
15	147	152	148	732	732	732	50.0 *	8.8
16	73	95	76	164	241	195	50.0 *	2.3
17	20	35	27	320	493	407	50.0 *	4.9
18	1405	1555	1472	2544	6027	4238	79.8	81.2
19	1	7	3	1	128	37	50.0 *	0.4
20	7	9	8	19	19	19	50.0 *	0.2
21	6	146	53	344	344	344	50.0 *	4.1
22	118	859	291	19	1026	265	50.0 *	3.2
23	3	2120	437	47	838	334	50.0 *	4.0
24	5	31	14	31	103	167	50.0 *	2.0

*) assumed value

No. 1 - 9 : Show Caves
 No. 10 - 18 : Visitor Mines
 No. 19 - 24 : Spas

INDOOR GAMMA CONTRIBUTION TO NATURAL RADIATION EXPOSURE IN ITALY

G.Campos Venuti(*), L.Lembo(+), S.Piermattei(°), G.Scarpa(+)

(* Istituto Superiore di Sanità and INFN-Sezione Sanità, Roma, Italy

(+) ENEA/Environmental Department, Roma, Italy

(°) ENEA/DISP, Roma, Italy

ABSTRACT

In the context of the National Survey on natural radiation indoors, based on a representative sample of 5000 dwellings, absorbed dose rates to air have been measured. Thermoluminescent dosimeters have been used and a well detailed measurement protocol has been elaborated. The paper analyzes the results obtained in 30% of the national sample. The arithmetic mean value obtained is 86 nGy/h. The distribution of absorbed dose rates in most of the Districts is well fitted by a Gaussian curve. The effective dose for the population has also been assessed, taking into account the occupation factors of dwellings.

INTRODUCTION

The influence of gamma and cosmic radiation on the effective dose received indoors by members of the public is generally far less important than that of radon concentration. However, measurements of the radioactive content of some natural and man-made building materials and surveys in certain areas, undertaken in Italy(1,2), indicated that a better evaluation of this irradiation source would be important. For this reason, in organizing the National representative survey on natural radiation indoors(3), it was decided to carry out measurements both of radon concentration and of absorbed dose rate to air. Moreover, the gamma measurements could also give information about the building materials as a source of indoor radon.

The survey is performed in each Italian District, in cooperation with local Health Services and Laboratories and involves a sample of 5000 dwellings selected through a two-stage stratified sampling technique.

METHODOLOGY

Due to the considerable number of District Laboratories involved, each one using different equipment and operators and having a wide spectra of thermoluminescent experience, it was decided to standardize - as far as possible - the whole measuring procedure by means of a detailed protocol. The use of the protocol should allow both to assure comparability of the data obtained in the different laboratories and to minimize dose uncertainties, so as to achieve an overall expected uncertainty in the range of (30÷40)% at 95% confidence level.

According to results in ref.4, LiF synthesized chips, either doped with Mg and Ti or with Mg, Cu and P, belonging to the same batch, have been used. The dosimeter is made of two pairs of TL chips, enclosed in light-tight plastic containers, 100 mg·cm⁻² thick. It is located, like the radon detectors, on a cupboard in one bedroom of each sampled dwelling.

The thermal cycles for re-use anneal, pre-heat and readout were defined, according with refs.4-7. In addition, two initialization cycles have been suggested for new detectors.

A check of sensitivity and zero signal of the reader at the beginning and the end of each daily reading cycle is required.

In order to further improve the homogeneity of the results obtained in the different laboratories, a number of preliminary tests are recommended in the protocol. Some of them regard just the detectors (individual sensitivity, batch homogeneity and fading), some others the whole TL system (reproducibility, and linearity) (8).

QUALITY ASSURANCE

A first intercalibration was carried out by exposing a sample of dosimeters prepared by each participating laboratories, to the beam of a Cs-137 source. Secondly, another set of dosimeters was exposed to the environmental radiation characterizing a selected high-background room, where dose rate had been previously evaluated. Both sets of detectors were read by the laboratories involved in the experiment, which ignored the actual value of the administered doses.

The results of the intercalibrations (see Fig.1) show good agreement among the different laboratories and confirm the reliability of the respective dosimeter systems.

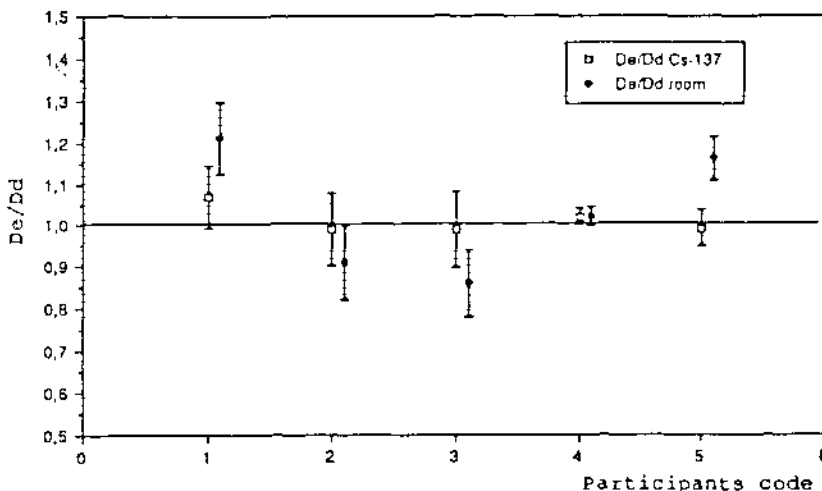

Fig.1 Results of the intercalibration tests (ratio between evaluated and delivered doses)

At the end of the 6-month period of indoor exposure, an analysis of readout values was made. The aim was to identify the possible outliers, by statistical comparison of readout values of the four detectors placed in each dwelling.

RESULTS

The survey is still in progress. At present the absorbed dose measurements have been completed in 7 Districts, corresponding to about 30% of the whole representative sample.

Figure 2 shows the best fits of absorbed dose rates to air evaluated in different Italian Districts. The goodness of the Gaussian fit is generally acceptable.

Figure 3 illustrates the absorbed dose rate distribution in all the dwellings considered. The values higher than 250 nGy/h all belong to one District and are also connected with the use of high-radioactivity building materials (e.g.tuffs).

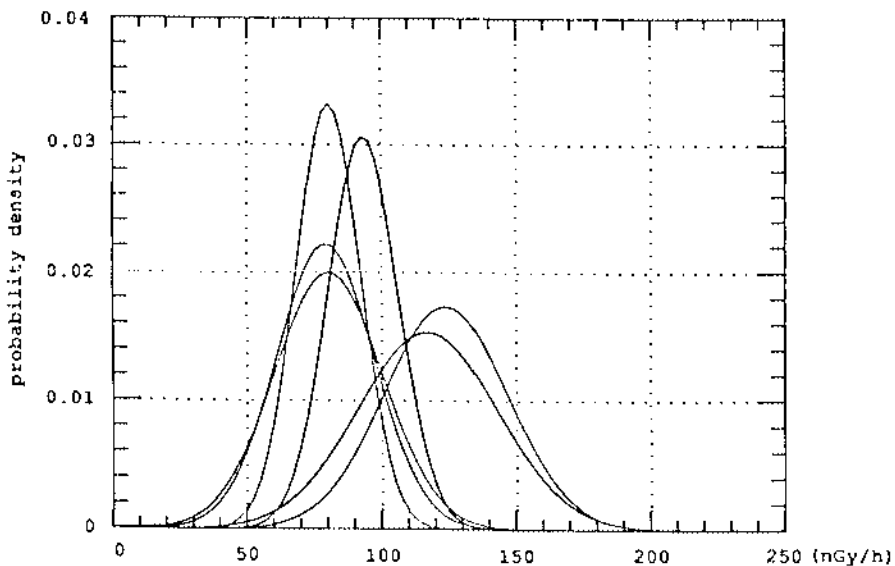

Fig.2 Best fits of absorbed dose rate to air evaluated in different Districts

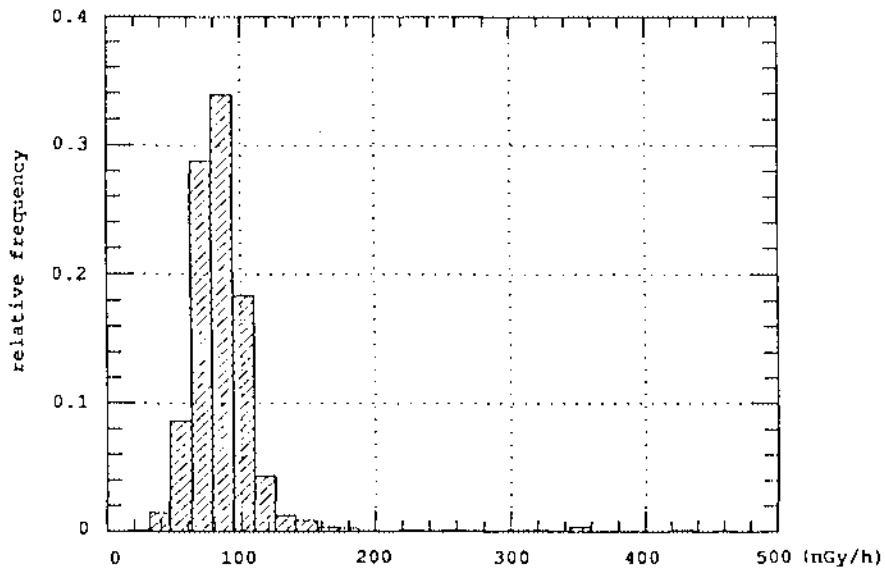

Fig.3 Absorbed dose rate distribution in 30% of the national sample

CONCLUSIONS

The mean value of the absorbed dose rate to air, weighted over the dwellings under consideration, is equal to 86 nGy/h. Mean values in the different Districts range from 75 to 165 nGy/h. The occupation factors indoors at home and elsewhere, in each District, obtained through questionnaires(3) filled by the families in the sample, have been taken into account. For the same purpose a rough evaluation of cosmic radiation

contribution has been made and this value has been subtracted for all dwellings. The mean effective dose for the population associated to γ indoors was thus assessed as 0.33 mSv per year.

The values obtained confirm that - in the radiation exposure of the population - the γ absorbed dose contribution is far less relevant than radon concentration.

REFERENCES

1. Busuoli, G., Lembo, L., Nanni, R. and Sermenghi, I., 1984, Indoor Gamma Exposure Measurements in Italy, *Radiation Protection Dosimetry*, 7, 313-316.
2. Campos Venuti, G., Colilli, S., Grisanti, A., Grisanti, G., Monteleone, G., Risica, S., Gobbi, G., Leogrande, M.P., Antonini, A. and Borio, R., 1984, Indoor exposure in a Region of Central Italy, *Radiation Protection Dosimetry*, 7, 271-274.
3. Bochicchio, F., Campos Venuti, G., Piermattèi, S., Risica, S., Tommasino, L. and Torri, G., 1990, Design of a Representative Nationwide Radiation Survey, Proceed. of the 5th International Conference on Indoor Air Quality, Toronto (Canada), 29 July-3 August 1990, vol.II, 20-25.
4. Driscoll, C.M.H., Barthe, J.R., Oberhofer, M., Busuoli, G. and Hickman, C., 1986, Annealing procedures for commonly used radiothermoluminescent materials, *Radiation Protection Dosimetry*, 14, 17-32.
5. Horowitz, Y.S., 1990, Study of the Annealing Characteristics of LiF: Mg, + Ti, Using Computerized Glow Curve Deconvolution, *Radiation Protection Dosimetry*, 33, 255-258.
6. Lembo, L., Pimpinella, M., Monteventi, F., De Maio, V., Poli, R. and Sermenghi, I., 1991, Una analisi comparativa delle caratteristiche dosimetriche di alcuni materiali termoluminescenti, Proc.XXVI Congresso Nazionale AIRP (Italian Radiation Protection Association), Verona (Italy), 13-15 Sept 1989, 435-445.
7. Scarpa, G., Moscati, M. and Soriani, A., Studio sulla tecnica di azzeramento e di lettura del LiF: Mg, Cu, P, Proc.XXVI Congresso Nazionale AIRP (Italian Radiation Protection Association), Ferrara (Italy), 16-18 Sept.1991 (in press).
8. IEC Publication 1066, 1991. Thermoluminescence Dosimetry Systems for Personal and Environmental Monitoring.

Acknowledgements

The authors are very grateful to the personnel of the Laboratories for the environmental radioactivity control of Friuli Venezia-Giulia, Trento, Bolzano, Emilia-Romagna, Veneto, Toscana and Umbria, involved in TL measurements.

Thanks are also expressed to: G.Baldassarre (ENEA) for his cooperation and A.Grisanti (Istituto Superiore di Sanità) for his assistance in the experimental work, and P.Di Ciaccio for her technical support.

Lung Dose Modelling From Realistic Measurements Of Occupancy Exposure To Radon Progeny

Dr. A. Singmin
Thomson & Nielsen Electronics
Ottawa, Canada

Abstract

The risk of lung cancer resulting from exposure to radon, is directly related to the progeny concentration and the actual period of occupancy. Current exposure studies and dose models to date use the widely accepted protocol that the occupancy factor is 80%(1,2). Our experimental studies on real time simultaneous monitoring of both radon progeny and occupancy periods have shown that much greater accuracy in risk assessment can be achieved when occupancy periods are measured rather than assumed to be a constant 80%.

Introduction

The risk of lung cancer arising from exposure to radon progeny is directly related to the total cumulative exposure, expressed as the product of Working Level x Occupancy Factor. In order to improve the accuracy of estimation of the health risk associated with exposure to radon progeny, accurate measurements of personal occupancy are necessary. Customarily, an occupancy factor of 80% is assumed, in the absence of more appropriate data. A recent study undertaken by N.H Harley and B.R. Litt(3,4) utilized a passive radon gas monitor(CR39 alpha track) worn by the participants. Additionally, subjects were required to keep an activity log of where they had been and what they had done. An alternative approach undertaken by Thomson & Nielsen, is based on the simultaneous measurement of both the real time continuous radon progeny variations and the actual occupancy periods within that environment. All measurements were recorded automatically, without the need for any personal activity diaries. The data gathered from this study is later used for calculating WLM exposure levels based on direct measurements.

Experimental Measurements

The chosen study environment was the basement area of a typical family residence of four occupants. For this experiment, no attempt was made to distinguish individual family members. A continuous working level radon monitoring system(TN-WL-02) manufactured by Thomson & Nielsen, was configured to record hourly radon progeny concentration levels automatically. This system is based on the principle of active sampling of the ambient air onto a filter with subsequent determination of the gross alpha counts by a solid-state detector. Data from this system, collected over

a period of several months, was later analyzed on a standard PC computer to produce continuous hourly plots of the radon progeny. In addition, monitoring and recording of the occupancy periods were made using a customized surveillance system. Each time a family member entered the basement area, the system was activated to subsequently record the occupancy duration. The data from this system was also later analyzed on a PC and the two plots combined to form the composite exposure profiles, as seen in Figure 1.

Results

A summary of the results covering four consecutive days are shown below in Table 1. Random variations in both WL and occupancy patterns can result in a wide range of WLM values. Over a four day period, as seen in Figure 1, the working level concentration varies by a factor of 5:1. Occupancy patterns reflect typically the habits of two working adults and two school age children. Activity is greatest at times in the afternoon when the children return from school and also on Saturdays. During the hours of sleep there is obviously no activity in the basement and radon progeny levels then are less of an exposure risk.

	Table 1			
	<u>Thursday</u>	<u>Friday</u>	<u>Saturday</u>	<u>Sunday</u>
Rd Average	0.038WL	0.032WL	0.017WL	0.027WL
Rd std dev	0.012WL	0.010WL	0.005WL	0.005WL
Occupancy	13%	17%	30%	8%
WLM/yr	0.25	0.28	0.26	0.11

Based on these values a comparison can be made between calculations of exposure from actual and assumed occupancy factors. It is seen that under realistic conditions, the occupancy factor is not necessarily 80%. Previous studies in this basement area have determined the average annual value to be 0.04WL. Using the usual occupancy factor of 80%, the estimated exposure is given as:

$$\text{WLM/yr} = 0.04 \times 0.8 \times 730 \times 12 / 173 = 1.62$$

Using the measured values from table 1, the calculated exposure is given as:

$$\text{WLM/yr} = 0.028 \times 0.17 \times 730 \times 12 / 173 = 0.24$$

In terms of the effective dose equivalent, the conversion factor between dose absorbed in the bronchial region and exposure to radon progeny is: 10mSv/WLM, as adopted by the ICRP(8).

Conclusions

Commonly employed lung dose models i.e. Jacobi-Eisfeld(5), Harley-Pasternak(6) and James-Birchall(7), include a simple proportionality constant for the occupancy factor. We have seen however that the actual value can vary significantly and is not a constant. When estimating radon health risks therefore, it is preferable that both progeny and occupancy be measured continuously. This is entirely feasible using monitoring equipment from Thomson & Nielsen, additionally removing the encumbrance of having participants keep activity diaries. By going to a higher level of system sophistication, individuals within a monitored zone can also be analyzed separately.

References

1. U.S. Environmental Protection Agency and U.S. Department of Health and Human Services. A citizen's guide to radon. U.S. EPA Pamphlet No. OPA-86-004, 1986.
2. New Jersey Department of Health. A case-control study of radon and lung cancer among New Jersey women. New Jersey Department of Health, 1989.
3. Harley N.H. et al. Personal and home Rn222 and gamma-ray exposure measured in 52 dwellings. Health Physics, Vol.61, No.6, pp.737-744, 1991.
4. Litt B.R. et al. Validation of a personal radon monitor for use in residential Rn222 exposure studies. Health Physics, Vol.61, No.6, pp.727-735, 1991.
5. Jacobi W. et al. Dose to tissues and effective dose equivalent by inhalation of radon 222, radon 220 and their short lived daughters. Report Gesellschaft fur Strahlen- und Umweltforschung GSF-S-626, Munich, Germany, 1980.
6. Harley N.H. et al. Environmental radon daughter alpha dose factors in a five-lobed human lung. Health Physics, Vol.42, pp.789, 1982.
7. James A.C. et al: A dosimetric model for tissues of the human respiratory tract at risk from inhaled radon and thoron daughters. Proceedings of the 5th Congress of the International Radiation Protection Association, Jerusalem, March 1980.
8. International Commission on Radiological Protection. Limits for inhalation of radon daughters by workers, ICRP publication 32, Ann. of ICRP, 6(1), 1981.

WLM EXPOSURE CALCULATIONS

Using Measured Radon Daughter Values
and Measured Occupancy Values

Equipment: TN Proprietary Systems

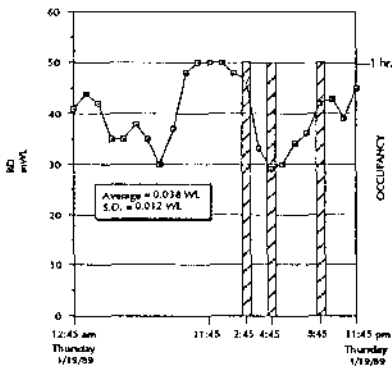

Percentage Occupancy = 3/24 hr = 13%

$$WLM = \frac{0.038 \times .13 \times 730}{173} = 0.02$$

$$WLM/yr = 0.02 \times 12 = 0.25$$

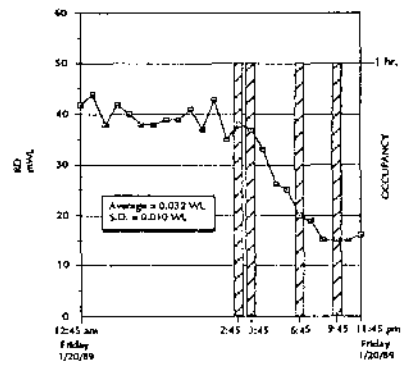

Percentage Occupancy = 4/24 hr = 17%

$$WLM/yr = \frac{0.032 \times .17 \times 730 \times 12}{173} = 0.28$$

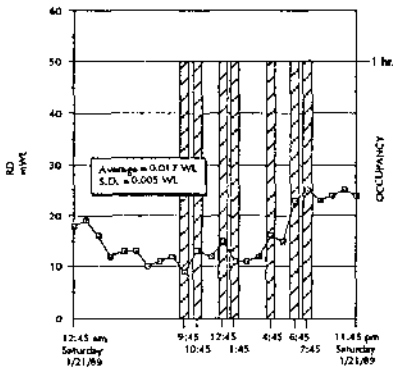

Percentage Occupancy = 7/24 hr = 30%

$$WLM/yr = \frac{0.017 \times .3 \times 730 \times 12}{173} = 0.26$$

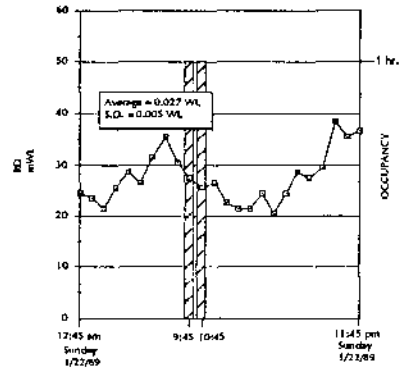

Percentage Occupancy = 2/24 hr = 8%

$$WLM/yr = \frac{0.027 \times .08 \times 730 \times 12}{173} = 0.11$$

FIGURE 1

PRESENTATION DES PRINCIPALES LECONS TIREES PAR LES PAYS MEMBRES DE LA COMMUNAUTE EUROPEENNE A LA SUITE D'ACCIDENTS OU D'INCIDENTS DE TRANSPORT DE MATIERES RADIOACTIVES

J. LOMBARD, C. RINGOT

Commissariat à l'Energie Atomique, Institut de Protection et de Sûreté Nucléaire, 92265 Fontenay-aux-Roses, France.

K.B SHAW, J.S. HUGHES

National Radiological Protection Board, Chilton, Didcot, U.K.

REVIEW OF MEASURES TAKEN TO IMPROVE THE SAFETY OF THE TRANSPORT OF RADIOACTIVE MATERIAL WITHIN THE MEMBER STATES OF THE EUROPEAN COMMUNITIES, AS A RESULT OF THE EXPERIENCE GAINED IN DEALING WITH ACCIDENTS AND INCIDENTS

Accidents and incidents involving the transport of radioactive materials have sometimes occurred in member states of the E.C. Most have not given rise to a significant radiological hazard but in some cases considerable remedial actions have had to be taken to deal with the radioactive material safely. In this paper the experience gained from dealing with these events has been examined. The lessons learnt from events that have occurred at various stages of transport operations are described, so as to be more widely available to those involved in the transport of radioactive materials. It is found that there are some general measures which can be taken that will reduce the frequency of these events, and facilitate the implementation of emergency procedures should such an accident occur.

Un certain nombre d'incidents ou d'accidents impliquant le transport des matières radioactives ont été recensés depuis 1975 dans les différents états membres des Communautés Européennes. La grande majorité d'entre eux n'a pas conduit à des conséquences radiologiques significatives, mais dans quelques cas d'importantes mesures d'intervention post-accidentelles ont dû être mises en oeuvre. L'examen de l'expérience tirée de ces incidents ou accidents a été fait. Les leçons tirées de ces événements, qui ont eu lieu à différentes étapes de l'opération de transport, sont décrites. Quelques mesures génériques pouvant être prises afin de réduire la probabilité d'occurrence de ces événements ou de faciliter les mesures d'intervention éventuelles ont été également identifiées.

INTRODUCTION

A la demande des Communautés Européennes, une banque de données regroupant la description des différents accidents ou incidents de transport de matières radioactives survenus au sein des Etats Membres de 1975 à 1986 a été réalisée par le CEA et le NRPB (1). Suite à cette première étude, l'analyse

des principales leçons tirées de ces événements a été faite (2).

Les principaux événements retenus ont été regroupés selon différentes rubriques, en fonction de leur cause principale, afin de pouvoir tirer des leçons génériques pour chacune des 10 rubriques suivantes :

1) PREPARATION ET FABRICATION DU COLIS :

La première étude (1) avait montré que les expositions les plus sévères avaient résulté d'accidents de transport de sources pour la radiographie industrielle. A titre d'exemple, on peut citer le cas d'un gammagraphe qui a été transporté pendant 18 heures avec sa source non protégée (hors de son tube guide). Il en est résulté une exposition de l'ordre de 200 mSv pour l'un des opérateurs. Cet accident n'aurait pas eu lieu si l'opérateur avait vérifié la position de la source avant le transport. Suite à de tels accidents, un code de bonne pratique a été rédigé au Royaume-Uni en 1975 insistant sur la nécessité d'une bonne préparation du colis. Depuis la diffusion de ce code, la fréquence de ce type d'événements a décru.

Après le naufrage du Mont Louis, quelques uns des colis d'UF6 avaient des protège-vannes détériorés. De nouveaux protège-vannes ont depuis été mis au point.

2) ETIQUETAGE ET DOCUMENTATION :

Certains colis radioactifs, trouvés sans étiquette, ont été ouverts sans précautions particulières. Ceci démontre l'intérêt du bien-fondé du suivi des procédures administratives en la matière.

Après un incident mettant en cause une grande source, le nom et le numéro de téléphone de l'expéditeur ont été clairement indiqués sur ces colis afin que l'on puisse le joindre immédiatement, sans alerter systématiquement les équipes d'intervention d'urgence.

3) OPERATION DE TRANSPORT PROPREMENT DITE :

La fixation des colis à l'intérieur du moyen de transport est un élément essentiel de sûreté. Différents accidents routiers, ferroviaires ou maritimes ont eu des conséquences significatives parce que le colis a été expulsé lors d'un accident ou a été endommagé lors du transport. Des codes de bonne pratique pour l'arrimage ont été développés depuis pour le transport routier et maritime.

Du minerai d'uranium concentré est transporté par mer dans des fûts. Lors de leur transport ou de leur manutention plusieurs fûts ont été percés, dispersant le minerai dans le navire ou sur le quai. Depuis, ces fûts ont été placés dans des conteneurs répondant aux normes ISO, ce qui a permis de diminuer la fréquence de ces accidents et de limiter la contamination à l'intérieur du conteneur.

4) MANUTENTION :

Bon nombre de petits colis ont été écrasés lors de leur chargement/déchargement dans un aéroport. Ces colis étaient posés sur un chariot de manutention qui devait franchir des ralentisseurs. Lorsque la vitesse du véhicule était trop importante, des colis tombaient et étaient écrasés. Depuis la pose d'une cage autour du chariot, la fréquence de ces événements a considérablement décru.

5) CONTROLE DE LA RADIOACTIVITE :

De nombreuses fausses alertes ont été déclenchées suite à une mauvaise mesure du niveau de radioactivité. L'utilisation d'appareils appropriés, par des gens qualifiés devrait pouvoir y remédier.

Par exemple, les colis en transit dans un aéroport étaient entreposés dans un local équipé d'un détecteur mural. Cet instrument, qui avait un seuil de détection trop bas, a été mis hors d'usage suite à de nombreux déclenchement intempestifs. Il a été finalement décidé de ne plus l'utiliser et de contrôler chaque colis par un appareil manuel après avoir pris soin de bien éloigner le colis de ceux déjà contenus dans le local de transit.

6) ASSURANCE DE LA QUALITE :

Le dispositif de fermeture d'un type d'emballage a été modifié sur tous à l'exception d'un seul qui n'était plus recensé, et lors de l'utilisation de cet exemplaire, l'exposition sévère du personnel a pu être évitée de justesse.

Les procédures d'assurance de la qualité du fabricant de ces emballages ont été mises en défaut.

7) FORMATION :

Lors de certains accidents ou vols, le chauffeur d'une importante société sous-traitante ne savait pas qui contacter. Dans ce but, des cours de formation et des plaquettes d'information ont été réalisés.

8) ORGANISATION ADMINISTRATIVE :

Lors du retour d'un colis, un réceptionniste, ignorant que le flacon était brisé, a été irradié. L'organisation du service "retour client" de cette société commercialisant des sources a été revue afin de considérer tout colis comme a priori suspect.

9) PROCEDURES D'INTERVENTION POST ACCIDENTELLES :

Suite au renversement d'un camion transportant des combustibles irradiés, il a fallu attendre une journée avant qu'une grue capable de soulever le colis n'arrive sur les lieux. Le recensement des grues de fort tonnage a été, depuis, réalisé.

10) RISQUES NON RADIOACTIFS :

Le risque principal de l'UF6 est le dégagement d'HF en cas d'incendie ou de contact avec l'humidité de l'air ou avec l'eau. La prise en compte de ce risque chimique, depuis l'accident du Mont Louis, a fait l'objet de réflexions à l'AIEA en vue de développer une réglementation pour le transport de cette matière. Un guide a été publié dans ce sens récemment par l'AIEA.

CONCLUSION

Plusieurs millions de colis radioactifs sont transportés chaque année dans les 12 pays membres de la Communauté Européenne, la plupart étant des colis de sources à usage industriel (gammagraphes) ou médical. On estime à environ quelques dizaines, voire à une centaine le nombre d'incidents ou d'accidents significatifs mettant en jeu chaque année des matières radioactives lors des transports réalisés au sein de ces pays.

Au vu de la diversité de ces transports, il est difficile de tirer des leçons génériques de ces événements. L'enquête réalisée a toutefois permis d'identifier des cas types selon leur origine et de recenser quelques mesures aisément généralisables à un type de transport. Il conviendrait maintenant de diffuser au mieux cette expérience et de continuer une telle analyse afin de pouvoir recenser d'éventuels autres cas types.

REFERENCES

1. LOMBARD J, RINGOT C, TOMACHEVSKY E, HUGHES J.S, SHAW K.B.
Review Analysis and Report of the Radiological Consequences Resulting from Accidents and Incidents Involving Radioactive Materials during Transport in the period 1975-1986 by and within Member States of the European Communities - CEC Report EUR 12768 EN, Directorate - General Energy - 1990 -
2. HUGHES J.S, LOMBARD J, RINGOT C, SHAW K.B.
Review of Measures Taken to Improve the Safety of the Transport of Radioactive Material within the Member States of the European Communities, as a Result of the Experience Gained in Dealing with Accidents and Incidents. A paraître.

REMERCIEMENTS

Cette communication présente les résultats d'études financées par la Commission des Communautés Européennes - Direction Générale de l'Energie (DG XVII) que les auteurs tiennent tout particulièrement à remercier.

A TRANSPORT ACCIDENT AND INCIDENT DATABASE

B C Ross
Health and Safety Executive
Magdalen House, Bootle, UK

K B Shaw & J S Hughes
National Radiological Protection Board
Chilton, Didcot, Oxon, UK

C K Wilson
Department of Transport
London, UK

Abstract

A database of UK transport accidents and incidents involving radioactive materials assists those responsible for regulations and those who undertake transport operations. Data have been analysed from 1964 to 1990: accidents and incidents involving radioactive materials are infrequent and significant radiation exposures are rare. Inadequate preparation of packages has, however, resulted in unnecessary radiation exposures. The main areas for improvements are in quality assurance procedures, and in the training of staff.

Introduction

In the UK, a transport accident and incident database has been established through the cooperation of the Health and Safety Executive (HSE), Department of Transport (DTp) and the National Radiological Protection Board (NRPB). Information on events involving the transport of radioactive materials since 1964 has been obtained: data came from the files of HSE, DTp, NRPB and consignors and carriers of such materials. The main purpose of the databank was to assist in the assessment of the radiological impact of transport accidents and incidents on both workers and members of the public. Additionally, it would provide information pertinent to future transport legislation, codes of practice, and regulatory activities.

Database

For each event, information was obtained on the technical details of the source and package, the mode of transport, and any radiological consequences. Any other relevant information available on the event was also recorded. The data were transferred to a computer database to facilitate analysis: a coding system was developed in order to categorise each event. Up to the end of 1990 the database contained 406 events, the majority of which were reported under informal notification arrangements. The database is updated annually and reviews are published^(1,2).

The level of detail of significant information found in reports is variable: there are differences between modes of transport and information is sparse in some of the early reports. Steps have been taken to improve the uniformity of reporting.

Results

Classification and analysis of events by category of material are given in Table 1. Transport operations are divided into two parts, the movement or transport phase and the handling phase. There is a further distinction in each phase between accidents and incidents. A number of the transport incidents were non-events or false alarms but they did involve an emergency response. Of the 147 handling accidents involving radioisotopes, most occurred at airports during the 1970s and were caused by packages being damaged during handling and unloading operations using fork-lift trucks. Improved handling techniques have virtually eliminated this type of accident. All the incidents, involving the transport of irradiated nuclear fuel and residues by rail, were minor events such as derailments during shunting operations: none of these had any radiological consequences.

Table 1: Classification and analysis of events by category of material

Category of material	Transport		Handling		Totals
	Accidents	Incidents	Accidents	Incidents	
Uranium ore concentrate	2	8	12	1	23
Pre-fuel material	5	3	0	2	10
New fuel	1	3	0	0	4
Irradiated fuel	4	33	0	7	44
Residues	4	30	2	6	42
Radioactive wastes	3	5	0	2	10
Radioisotopes	20	25	147	33	225
Radiography sources	8	18	2	20	48
Totals	47	125	163	71	406

An important analysis is that of the effects on packages, this is detailed in Table 2. In 117 events there were no consequences but the potential existed. For 43 events there were administrative errors or false alarms. The remaining 246 events resulted in damaged packages or were due to faulty packages. Loss of containment occurred in 24 cases and many of these involved drums of uranium ore concentrate damaged in transport. These drums are now containerised and such events are now rare.

Table 2: Analysis of effects on packages

Type of event	Number of events for each package type				Total
	Excepted	Industrial	Type A	Type B	
Damage with loss of containment	2	15	7	0	24
Damage with an increase in dose rate, without loss of containment	0	0	5	1	6
Damage without increase in dose rate or loss of containment	6	5	161	4	176
No damage or increase in dose rate but with potential to cause damage to the package	11	8	37	61	117
Increase in dose rate or loss of containment owing to faulty packages	2	2	19	17	40
No damage to package. Minor events, e.g. labelling errors and false alarms	11	5	15	12	43
Total	32	35	244	95	406

The radiological consequences of accidents resulting in the release of unsealed radioactive material from packages have been very low: intakes have been insignificant. However, some events have involved the transport of inadequately shielded gamma ray sources and have led to appreciable exposure of workers. The exposure of members of the public from such events has been negligible. The highest occupational exposures were recorded by personal dosimeters and assessment. Only ten workers were reported as receiving doses above 100 mSv: the distribution of doses over 1 mSv is given in Table 3.

Table 3: Distribution of doses to workers

Dose range (mSv)	Number of workers	Number of workers with site radiography sources
1-10	22	16
11-100	15	15
101-1000	9	9
> 1000	1	1

The single largest dose involved a site radiography source which fell out of its container owing to the failure of a retaining bolt. A 190 GBq ^{192}Ir source was exposed outside the container for approximately 17 h before being discovered; three workers received whole-body doses of about 2400, 500 and 50 mSv. All of the remaining events with doses above 100 mSv were similar: all involved site radiography sources which fell from, or were not replaced in, their containers. On one occasion the exposure was found to be deliberate, and on another film badges were incorrectly used and led to a reported dose greater than the assessed dose. On several occasions it was noted that no monitoring had been carried out before transport of the sources. Most such events occurred in the 1970s: improvements have been made in the training, supervision and quality assurance, and no such events have occurred since 1985.

Discussion

The compilation and analysis of information on accidents and incidents involving radioactive materials during transport both assists those responsible for its regulation and those who consign and carry those materials. The lessons learnt from one event can often help to avoid similar occurrences.

The correct assembly of the package has been shown to be most important and adequate quality assurance measures are required. Regular reviews of operating procedures⁽⁷⁾ are necessary to ensure that all exposures are as low as reasonably achievable.

Adequate training of staff and the availability of information are important considerations. The level of training will depend upon the nature of the work⁽⁴⁾.

Conclusions

A database of accidents and incidents during the transport of radioactive materials in the UK has been compiled, covering the period 1964-1990: the data are reviewed annually. Some 400 events are recorded in the database, of which 70 involved either a release of radioactive material or inadequate shielding or loss of shielding. As a result, about 40 workers have received doses in excess of 1 mSv and 10 have exceeded 100 mSv. Accidents and incidents involving radioactive materials during transport are comparatively rare but their frequency can be further reduced by improvements in quality assurance procedures and in the training of staff.

References

1. Shaw K B, Hughes J S and Wilson C K. The radiological impact of transport accidents. Nucl. Energy, 1990, 29, No. 6, Dec., 409-412.
2. Shaw K B, Hughes J S, Wilson C K and Ross B C. UK transport events and international cooperation. Int. J. Rad. Mat. Trans. Vol 1, No. 3, 1990, 145-149.
3. Pecover C J and Ross B C. Compliance assurance and regulatory agency's cooperation in the UK. Proceedings of the 9th Int. Symp. on the Packaging and Transportation of Radioactive Materials (PATRAM '89) Vol 1, 483-489.
4. The Ionising Radiations Regulations 1985. SI No. 1333, 1985, HMSO, London.

—ooo—

REFLEXIONS SUR L'IMPACT DES NOUVELLES RECOMMANDATIONS DE LA CIPR
SUR LA REGLEMENTATION DES TRANSPORTS

—ooo—

Impact of the new ICRP recommendations
on the LAEA transport regulations

—ooo—

Jean HAMARD
Commissariat à l'Energie Atomique
IPSN-DPHD-SEGR
Claude RINGOT
Commissariat à l'Energie Atomique
IPSN-DSMR
60-68, avenue du Général Leclerc
B.P. N°6
92265 FONTENAY AUX ROSES CEDEX
Tél : 46.54.72.65
46.54.80.09
Fax : 46.54.91.90
46.54.80.09

Gérard HENISTAN
Alain LAUMOND
Electricité de France
Direction Production Transport
Service des Combustibles
23 bis, avenue de Messine
75384 PARIS CEDEX 08
Tél : 40.42.66.34
40.42.49.46
Fax : 40.42.36.83

—ooo—

ABSTRACT

The recent ICRP recommendations (ICRP Publications n°60 & 61, 1991) contain some new provisions, that can have an effect upon the AIEA radioactive materials transportation recommendations. The most important are :

- those provisions relating to the occupational & public dose limits and to the annual limits on intake based on the new dose limits,
- and the provisions for potential exposures and for occupational exposure in emergencies.

This paper assesses the effects of all those provisions upon the classification of workplaces, upon the dose rate levels close to the transportation packages, upon the activity limits for type A packages, and finally upon the spent fuel and radioactive waste packages design.

—ooo—

1/ LIMITES DE DOSE ANNUELLES POUR LES TRAVAILLEURS ET POUR LE PUBLIC

L'abaissement de la limite de dose annuelle moyenne de 50 mSv à 20 mSv recommandé par le CIPR (1) ne devrait pas poser de problème important pour la surveillance des travailleurs impliqués dans les transports. Bien que les valeurs publiées soient rares et incomplètes, les doses annuelles les plus élevées reçues en France et dans divers pays pour les travailleurs des transports sont de l'ordre de 15 mSv par an et ne concernent qu'un nombre très limité de personnes.

Les nouvelles recommandations de la CIPR fixent à 1 mSv en moyenne sur 5 ans la limite de dose annuelle pour les individus du groupe critique du public, cette limite pouvant être dépassée au cours d'une année isolée si la moyenne sur 5 ans ne dépasse pas 1 mSv. L'application de cette limite de dose pourra conduire à considérer comme travailleurs exposés professionnellement un certain nombre de travailleurs qui étaient jusqu'à présent considérés comme des individus du public et exercer une surveillance adéquate des expositions reçues. Le nombre de travailleurs concernés n'a pas encore été évalué mais ne serait sans doute pas très élevé. Cette mesure a le mérite de clarifier la situation d'un certain nombre de travailleurs et de marquer nettement la différence entre l'exposition professionnelle et l'exposition du public dans les transports.

2/ DETERMINATION DES DEBITS DE DOSE AU CONTACT ET A DISTANCE ET DES LIMITES DE CONTAMINATION DE SURFACE DES COLIS

Ces limites ont été définies pour atteindre les objectifs suivants :

- limiter l'exposition des professionnels amenés à manipuler ou à séjourner à proximité des colis de matières radioactives,
- limiter l'exposition des équipages des avions ou des autres moyens de transport ainsi que des personnes du public utilisant ces moyens de transport ou séjournant près des lieux d'entreposage en transit,
- limiter à 0,10 mSv par voyage la dose reçue par les films photographiques.

Il faut reconnaître que les données relatives aux objectifs de dose et aux scénarios et modalités d'exposition figurant dans les différents documents relatifs au transport (2.3) sont confuses et manquent de cohérence. Il sera nécessaire de réviser ces données en clarifiant les objectifs et en redéfinissant de façon précise ces scénarios et modalités d'exposition supportant ces différentes limites. Ceci ne devrait cependant pas conduire à des modifications importantes de ces dernières.

3/ CONTRAINTES DE DOSE

La réglementation des transports de l'AIEA (Agence Internationale de l'Energie Atomique) pour le calcul des distances de séparation et des débits de dose dans les locaux occupés de façon régulière, se fixe pour objectif en application du principe d'optimisation le respect d'une limite de dose annuelle de 5 mSv pour les travailleurs. Il est nécessaire de rappeler à ce propos que la fixation de ce type de "contrainte de dose" ne relève pas d'une décision internationale, sauf si un consensus suffisant existe sur ces valeurs. La fixation de contraintes de dose relève en effet des autorités nationales ou même de décisions prises par les directions des compagnies ou des installations. Ce point devra être discuté lors des réunions internationales pour la révision de la réglementation des transports.

4/ CONDITIONS ACCIDENTELLES - CALCUL DES VALEURS A1 et A2

Dans la réglementation actuelle pour le calcul des valeurs A1 et A2 admissibles dans un emballage de type A on définit des niveaux de dose considérés comme admissibles en cas d'accident par référence aux valeurs des LAI ou des limites de dose à l'organisme entier ou à la peau pour les travailleurs. La CIPR a publié récemment (4) de nouvelles valeurs des LAI mais il ne paraît pas judicieux de recalculer les valeurs A1 et A2 en tenant compte de ces valeurs qui ne prennent pas en compte le nouveau modèle respiratoire de la CIPR.

En conditions accidentelles, il n'y a pas de limites de dose mais la CIPR recommande d'utiliser des "niveaux d'action ou d'intervention" tels que ceux proposés dans la publication CIPR 40 (5) au dessus desquels il peut être nécessaire d'effectuer certaines actions ou interventions définies par l'autorité compétente.

Dans ces conditions les valeurs de A1 et A2 pourraient être recalculées en tenant compte du "niveau d'intervention" dont les valeurs pourraient être identiques aux niveaux de dose considérés actuellement comme acceptables en cas d'accident ce qui éviterait de modifier profondément les valeurs actuelles et de désorienter les utilisateurs.

5/ CONCEPTION DES EMBALLAGES - PRISE EN COMPTE DES NOUVELLES VALEURS DE WR

Dans le cas des transports de combustibles neufs et de combustibles irradiés, les débits de dose à distance et au contact des colis étaient parfois mesurés sans tenir compte des neutrons, et lorsqu'ils étaient mesurés, on attribuait à ceux-ci un facteur de qualité de 10. Il va falloir à présent tenir compte des neutrons en leur affectant un facteur de pondération WR fonction de l'énergie (qui remplace le facteur de qualité Q) de 20.

Or, il se trouve que la composante neutronique peut représenter une fraction importante du débit d'équivalent de dose total. Dans tous les cas où, en tenant compte du rayonnement γ seul, les limites de débit de dose au contact et à distance étaient approchées, la prise en compte du rayonnement neutronique va majorer ces débits de dose dans une proportion qui n'est pas encore exactement connue mais qui pourrait dépasser ces limites. Dans ces conditions, certains transports ne seront plus conformes et une solution devra être trouvée : transitoire d'abord (dérogations) puis définitive (coques de protection, réduction des activités transportées, modification des emballages existants ou création de nouveaux emballages).

L'impact économique de cette modification peut donc être important.

6/ VERIFICATION

En vue de s'assurer du respect des limites de dose pour les travailleurs et le public la CIPR recommande que les doses reçues par les travailleurs soient relevées et vérifiées périodiquement, et l'AIEA recommande d'effectuer ce relevé tous les cinq ans. Cette recommandation revêt une importance certaine dans les transports où la surveillance des travailleurs exposés est rendue difficile par leur dispersion et leur mobilité et où la surveillance du public est également difficile. Elle est réalisée en France et dans divers autres pays et peut être effectuée directement ou au moyen de modèles développés par l'AIEA (6).

Cet inventaire des problèmes n'est pas exhaustif et nous l'avons limité qu'à ses aspects les plus importants.

7/ CONCLUSION

La qualité d'une réglementation s'évalue dans la durée et une réglementation, pour être respectée, doit évoluer dans la continuité. On peut également juger de la qualité d'une réglementation en fonction des résultats obtenus. Ceux-ci sont évalués régulièrement dans quelques pays et en France depuis 1978. En France, entre 1978 et 1990, alors que le nombre de transports de matières radioactives augmentait dans des proportions considérables (de 40 000 à 173 000 colis pour les produits radio-pharmaceutiques), les doses moyennes pour les personnels les plus exposés sont demeurées stables et relativement faibles ainsi que la dose collective (de l'ordre de 1 homme.Sievert), situation qui peut apparaître relativement satisfaisante.

Néanmoins, l'évolution de la doctrine de la CIPR, reprise dans les normes de base de l'AIEA, et la nécessité de corriger certaines imperfections devront être prises en compte lors de la prochaine révision de 1995. Il faut souhaiter que, compte tenu de certains correctifs et de certaines mises à jour rendus nécessaires par l'évolution de la réglementation internationale, l'originalité de la réglementation des transports soit conservée et qu'une certaine continuité des règles de sûreté et de radioprotection soit préservée.

—ooo—

BIBLIOGRAPHIE

- (1) 1990 Recommendations of the international Commission on Radiological Protection. ICRP publication 60 - Pergamon Press.
- (2) Regulations for the safe transport of radioactive materials - safety series n°6 1985 Edition IAEA.
- (3) Explanatory material for the IAEA regulations for the safe of transport of radioactive material (1985 edition amended 1990) safety series n°7 IAEA Vienne 1990.
- (4) Annual limits of radionuclides based on the 1990 recommendations ICRP publication 61-1990, Pergamon Press.
- (5) Protection of the public in the event of major radiation accidents principles for planning. Publication ICRP 40 - Vol 14 n°2 1984 - Pergamon Press.
- (6) Evolution of radiation doses received by workers and the public during the transportation of radioactive materials in France. J. Hamard and al. PATRAM 89 - Washington.

—○○—

**RADIATION DOSES FROM THE TRANSPORT OF RADIOACTIVE MATERIAL
IN THE UNITED KINGDOM**

C K Wilson
UK Department of Transport
and
K B Shaw
UK National Radiological Protection Board

ABSTRACT

The assessment of the doses arising from the incident-free transport of radioactive material in the United Kingdom is performed periodically by means of a programme of work looking at the land, sea and air modes in turn, separately. A database containing details of UK accidents and incidents involving radioactive material over a period of more than twenty five years has been established.

The doses from routine operations are generally low, apart from those of a small number of drivers regularly delivering technetium generators for medical use. The highest accidental exposures have been from the transport of inadequately shielded industrial radiography sources.

INTRODUCTION

The transport of radioactive material in the United Kingdom is controlled by regulations based upon the International Atomic Energy Agency's model regulations¹. These regulations require that the exposures from the handling, storage and transport of radioactive material shall be kept as low as reasonably achievable, economic and social factors being taken into account. However, the dose rates around packages containing radioactive material can be as high as 10mSv/h. The justification for the continued use of these levels is that radiation exposures arising from transport are in fact low and that the regulations provide for their periodic assessment by the Competent Authority. In the United Kingdom the Department of Transport, as Competent Authority, has instigated a programme of assessment of the exposures arising from the transport of radioactive materials. This is done on a cyclical basis looking at each transport mode in turn under incident free conditions^{2,3}. A database of reported transport accidents and incidents in the UK and their radiological consequences is also maintained⁴. This work is performed under contract to the Department by the National Radiological Protection Board a statutory body one of whose functions is to provide advice on radiological protection matters to government departments.

SEGREGATION

It is a basic requirement of the IAEA Regulations that radioactive material is properly segregated both from people and photographic film. For the former, the Regulations prescribe limiting values of annual dose of 5mSv for workers

and 1mSv for members of the public and from these values segregation distances can be calculated using hypothetical but realistic models. If these criteria are met in practice neither special work patterns nor detailed monitoring of radiation doses are required.

NORMAL TRANSPORT

(i) Transport Characteristics

It is convenient to consider the transport of radioactive material under three broad headings: unirradiated nuclear fuel cycle materials; irradiated nuclear fuel cycle materials including wastes; and radionuclides for medical and industrial use.

The greatest weight of radioactive material transported is in unirradiated nuclear fuel cycle materials such as uranium ore concentrate, or uranium hexafluoride. These are bulky materials of low specific activity. Uranium ore concentrate travels by road or sea in 17 tonne loads of industrial grade steel drums overpacked into 6 or 12 metre long freight containers; uranium hexafluoride whether natural, depleted or enriched travels in purpose-built cylinders holding between 2 and 12 tonnes, usually by road or sea.

Irradiated nuclear fuel cycle materials such as imported spent nuclear fuel from European and Japanese power and research reactors travel by sea with associated secondary rail journeys; domestic irradiated nuclear fuel travels mainly by rail. The highest activity of radioactive material transported is found in this category; a typical flask of seven PWR elements contains of the order of several hundred petabecquerels.

Low level waste arises from both the nuclear fuel cycle and from isotope production and is transported by road and rail to an authorised repository. Its transport is, as yet, not radiologically significant.

The transport of radionuclides for medical use, both within the UK and abroad is extensive by road, sea and air: this category of material accounts for the greatest number of movements and the largest number of packages moved with around half a million packages transported each year⁵. Roughly 90% of these contain insignificant quantities of radionuclides which are exempt from many of the design and use requirements of the transport regulations. The remainder are radiologically significant and are the major source of worker exposure in routine transport.

ii) Exposures

Individual and collective doses for workers and members of the public have been estimated and are summarised in Tables 1 and 2.

Table 1: Worker Exposure

Mode	Max. Individ. (mSv)	Collective (manSv)
Road/Rail	16.0	0.4
Air	0.4	0.1
Sea	0.4	-

Table 2: Exposure of Members of the public

Mode	Max. Individ. (mSv)	Collective. (manSv)
Road/Rail	0.006	0.04
Air	0.1	0.5
Sea	0.05	-

The highest occupational doses arise in road transport from the movement of technetium generators for hospital use. Doses to members of the public are low: the highest doses are from the air transport of medical radionuclides⁶.

ACCIDENTS/INCIDENTS

Accidents and incidents occur in all modes of transport to all types of goods, radioactive materials are no exception. Although the lower types of packaging for radioactive materials are not required to retain their contents in the event of a severe accident, experience over 25 years in the UK has shown that such packages do retain their contents and shielding in most accident conditions. The higher grade of packaging, Type B, is required to meet severe accident conditions without significant loss of contents or shielding and no such package has lost its contents in the UK.

The UK has a transport event database on accidents and incidents involving radioactive material; since 1964 some 400 events most of which have had trivial radiological consequences have been recorded.

Analyses of the UK events shows that in 43% of the cases the package was damaged but that there was no increase in radiation level or loss of containment; in 39% of the cases no damage occurred to the package. Radiological consequences were possible in the remaining 18% of the cases but significant exposures occurred in only a few, all involving site radiography sources. The highest radiation doses resulted from faulty packages where the radiography sources were not properly shielded.

LOOKING AHEAD

The new ICRP recommendations will have an impact on transport. There will be greater pressures to constrain doses and this could involve substantial increases in some transport costs. The application of ALARA will need to be carefully examined. The permitted surface dose rates on packages will need to be reviewed and certain handling procedures may need to be revised.

CONCLUSIONS

Although the exposures from incident free transport are currently generally low they are dependent upon particular work and traffic patterns and the need for continuous review is, therefore, justified. The analysis of accidents and incidents confirms the adequacy of the IAEA packaging standards but emphasises the need for the application of quality assurance in transport.

The highest individual occupational doses arise from the transport of technetium generators. For a few workers these can be as high as 16mSv. Other transport occupational exposures are almost an order of magnitude lower.

The collective dose to members of the public due to the transport of radioactive materials by road and rail has been estimated at 0.04 manSv. For the transport of radioactive materials from the UK by air, the collective dose has been estimated as 0.5 manSv. No estimate of collective dose has been made for sea transport.

The new ICRP recommendations will have an effect on transport: in particular the application of dose constraints needs to be carefully considered. Transport is an international matter and requires international consensus.

References

1. International Atomic Energy Agency. Regulations for the safe transport of radioactive material. IAEA Vienna, Safety Series No 6, 1985 Edition (As amended 1990)
2. Gelder R, Hughes J S, Mairs J H and Shaw K B. Radiation exposure resulting from the normal transport of radioactive materials within the United Kingdom. NRPB R155 1984.
3. Shaw K B, Gelder R and Wilson C K. Air and Sea Transport. Radiological Protection Bulletin No 106, Oct 1989.
4. Shaw K B, Hughes J S, Wilson C K and Ross B C. UK Transport events and international cooperation. International Journal of Radioactive Materials Transport. Vol 1,3,1990
5. ACTRAM 1987: Advisory Committee on the Safe Transport of Radioactive Materials. Transport of Radioactive Materials for Medical and Industrial Use. ISBN 0 11 752044 6. London, HMSO (1987).
6. Gelder R: Radiological Impact of the Normal Transport of Radioactive Materials by Air. NRPB M219,1988

STATUS OF SHIELDING ANALYSIS METHODS FOR TRANSPORT PACKAGES

C. V. Parks, B. L. Broadhead, and M. C. Brady

Oak Ridge National Laboratory*
Oak Ridge, Tennessee 37831

ABSTRACT

Shielding analysis methods for transport packages are becoming more important to the cask designer because optimized cask designs with higher payloads can yield doses near the limits set by regulatory authorities. Uncertainty arising from generation of radiation sources, selection of cross-section data, and the radiation transport methodology must be considered. Recent comparison studies using popular U.S. codes illustrate calculational discrepancies arising from each of these areas.

INTRODUCTION

Accurate results from shielding analyses of spent fuel transport packages (or casks) have become more important as the desire for optimized designs increases. In order to obtain accurate, defensible results, it is necessary to identify and evaluate uncertainties arising from three major analysis areas: radiation source generation, utilization of cross-section data, and radiation transport and dose evaluation. This paper reviews recent efforts carried out at Oak Ridge National Laboratory (ORNL) to evaluate the impact of various codes, data, and analysis assumptions on the calculation of radiation doses from spent fuel casks.

RADIATION SOURCES

In the United States, radiation sources for spent fuel and high-level waste are typically obtained with the ORIGEN2 or ORIGEN-S codes. ORIGEN-S and ORIGEN2 employ the same point depletion/decay methods and use virtually identical decay data and photon data. The different methods used to develop and supply burnup-dependent cross-section libraries to ORIGEN2 and ORIGEN-S represent the major difference between the codes.

Radiation source strengths calculated by ORIGEN2 and SCALE/ORIGEN-S have been compared for burnup values of typical light-water-reactor (LWR) fuel.¹ The photon source strengths and spectra showed good agreement. The primary discrepancy in the spectra was observed above 2 MeV where there can be a reversal in the magnitude of adjacent energy groups caused by the

*Managed by Martin Marietta Energy Systems, Inc, under contract DE-AC05-84OR21400 with the U.S. Department of Energy.

different strategy used to bin photons to assure energy conservation (important for accurate shielding analysis). Photon dose rates on the surface of a cast-iron cask were also calculated using the ORIGEN2 and SCALE/ORIGEN-S sources. For the pressurized-water-reactor (PWR) sources, the doses agree to within 1.8% at a 5-year cooling time and 5% at 50-year cooling. Results for the boiling-water-reactor (BWR) cases showed agreement within 2.9% and 6%, respectively, for the 5-year and 50-year cooling times. One current limitation of ORIGEN2 is that the photon spectrum is provided in a fixed group structure whereas ORIGEN-S can provide a spectrum in any user-specified format. Conversion of the ORIGEN2 spectrum to fit a cross-section group structure is an approximation and should be performed with care.

The neutron production rates obtained for the comparison study¹ indicate discrepancies between ORIGEN2 and SCALE/ORIGEN-S as large as 30% for spent BWR fuel. For PWR fuel, the sources agree to within 2%. ORIGEN2 does not provide a neutron energy spectrum, whereas ORIGEN-S uses measured isotopic spectral data to provide a spectrum in any user-specified group structure.

The comparison study demonstrated that radiation sources from ORIGEN2 and SCALE/ORIGEN-S agreed very well for decay-only cases (codes started with same isotopics). The largest discrepancies occur in situations where the actinide concentrations offer an important contribution to the radiation source. This fact implies that the discrepant results discussed above arise from differences in the burnup-dependent cross-section data and the methods used to generate the data. Validation against measured data is needed to determine the accuracy of the calculated radiation sources. Unfortunately, the availability of measured isotopic data is severely limited for many of the fission products and actinides (e.g., curium) that are important contributors to the radiation source.

The radiation source emitted by activated light elements in the hardware of LWR fuel must often be considered in a cask shielding analysis. Activation of ⁵⁹Co to ⁶⁰Co is of particular concern. Typically, analysts use activation ratios based on neutronic calculations or measurements to adjust the ORIGEN (2 or -S) input to enable reasonable source terms to be obtained for fuel hardware zones. Conservative assumptions to cover the large uncertainties associated with the initial concentration values and activation analyses are typically not a problem for transport cask design unless the designer significantly reduces the radial shield thickness (due to weight constraints) in the hardware regions.

CROSS-SECTION DATA

The thick shielding and, hence, deep-penetration characteristics found in spent fuel casks make calculated dose

rates particularly sensitive to the cross-section data. Several standard multigroup libraries were selected and/or altered by ORNL to analyze dose sensitivity due to resonance self-shielding, energy-collapsing spectrum, and parent fine-group data. A 1-D cylindrical cask model with a homogenized spent fuel source region and 38-cm-thick cast-iron body was used in the evaluation study.² Comparison of dose results using the different libraries showed (a) absence of resonance self-shielding for iron decreased the neutron dose 33%, (b) the neutron dose decreases 8 to 10% in going from ENDF/B-IV to ENDF/B-V data, (c) an inappropriate weighting spectrum for the neutron data can easily alter the neutron dose by a factor of 2, and (d) a fine-group (45 to 60) photon library needs to be utilized and/or careful attention paid to the collapsing spectrum for more accurate results. Improper weighting (e.g., concrete flux rather than iron flux) and use of broad groups in the important energies (1 to 3 MeV) yielded 30 to 50% changes in the photon dose. Although limited to spent fuel shielded by cast iron, this study does point out the common error of using "off-the-shelf" cross-section libraries without regard to particular aspects of the radiation source, geometry, and material compositions. Work has begun at ORNL to generate multigroup cross-section libraries specifically applicable to spent fuel cask analysis.

Cross-section interpolation techniques used in point kernel and point Monte Carlo codes can also lead to small cross-section changes that have a larger impact on the dose. For the iron cask above, varying the interpolation method from linear (QAD-CG) to log-log (QAD-CGGP) yielded a 2% change in the cross section, which was sufficient to cause an 8 to 10% variation in the dose results.

RADIATION TRANSPORT CODES

Time and available funds often dictate the selection of radiation transport techniques. Point kernel and 1-D discrete ordinates codes are often used by cask designers because they are fast, inexpensive, and relatively easy to use. In the past, Monte Carlo and two-dimensional (2-D) discrete ordinates codes were typically reserved for specific problems and/or to validate the simpler methods. However, cask vendors for the new cask designs being developed for the U.S. Department of Energy repository program are utilizing Monte Carlo (MCNP) and 2-D discrete ordinates codes (DORT) in their shielding analysis.

An evaluation of several codes used in the United States for cask shielding analysis has been performed using the cast-iron cask model (with homogenized fuel and basket region) described above.² All of the codes utilized ENDF/B-V data libraries. The results obtained from the SAS1/XSDRNPM sequence of SCALE indicate that 1-D discrete ordinates codes can be used to obtain acceptable sidewall doses for casks with height-to-

diameter (H/D) ratios greater than two. For dose locations at the cask axial midplane but away from the surface, slightly conservative (with respect to multidimensional calculations) results were observed. The 1-D results showed a 20% overprediction at 10 m from the cask surface. The QAD point kernel (gamma only) results similarly agreed quite well with multidimensional calculations on the cask sidewall surface, but were up to a factor of 2 conservative at dose locations 10 m from the cask surface. The point kernel methods also perform quite well for doses at the cask top and bottom.

Multidimensional calculations were performed using a 2-D discrete ordinates method (DORT) and two three-dimensional (3-D) Monte Carlo codes (SAS4/MORSE and MCNP). In general, the SAS4 and DORT agreement is quite good, generally within the SAS4 standard deviations. Comparing SAS4 and DORT versus MCNP also indicates very good agreement for the gamma doses, but the groupwise neutron doses from SAS4 and DORT are about 20% lower than those based on point cross-section values (MCNP).

The results of the comparison study discussed above are for a model with a homogenized (fuel assemblies and basket) source region. Modeling the assemblies (five) as an array of homogenized source zones within a 1-cm-thick steel basket increases the neutron dose by 6% and decreases the photon dose by 26%. The small increase in neutron dose (6%) is of only slight concern; however, the significant decrease (26%) in the photon dose indicates the improved accuracy that can be obtained with more detailed modeling of the source region. Work with explicit pin-by-pin models of the assemblies showed no significant difference from results obtained with a model using homogenized individual assemblies placed heterogeneously within the source region.

SUMMARY

The user must ensure that the codes and data interact effectively to produce an accurate shielding analysis of a cask. The available radiation transport codes are reliable tools when handled by the knowledgeable user. However, more work is needed to reduce and/or quantify the uncertainty in the dose arising from specific source characterization methods and cross-section libraries.

REFERENCES

1. Brady, M.C., Hermann, O.W., Wilson, W.B., 1989, Comparison of Radiation Spectra From Selected Source-Term Computer Codes, ORNL/CSD/TM-259.
2. Broadhead, B.L., Brady, M.C., Parks, C.V., 1990, Benchmark Shielding Calculations for the NEACRP Working Group on Shielding Assessment of Transportation Packages, ORNL/CSD/TM-272.

DEVELOPMENT OF EXPERT SYSTEM FOR TRANSPORT OF RADIOACTIVE MATERIALS

Y. Shigeta, Y. Kimura, H. Yabuta, K. Hasegawa, Y. Ikezawa

Department of Health Physics,
Japan Atomic Energy Research Institute,
Tokai-Mura, Naka-Gun, Ibaraki-Ken, Japan

ABSTRACT

In the first step for the AI application to radiation safety control, we have developed a prototype of the expert system for the transport of radioactive materials. The system is composed of three subsystems, which are "Judgment on the packages", "Diagnosis of conformity of the packages and the packagings", and "Judgment on transportable activities". With the system, it becomes easy to judge the type of the packages and the packagings, the labellings and the number of labels and transportable activities, etc. according to the regulation.

INTRODUCTION

Recently, an expert system(ES) which has functions to aid our interpretations and judgments is increasingly being used in a variety of business managements and manufacturing fields with the progress of the artificial intelligence(AI)-techniques.

In the field of radiation safety control, the technical system has been rapidly sophisticated with the specialization of radiation safety control techniques, and the work load has also been increasing with the increase in the number and the complexity of nuclear facilities. It is necessary for the experts on radiation safety control to promote the rationalization of their interpretations and judgments, the improvement of reliability on their judgments, the standardization of radiation protection procedure and the transmission of the accumulated knowledge. An application of AI to radiation safety control will facilitate to introduce the knowledges and the experiences of the experts, and also to utilize new knowledges and experiences with respect to radiation protection.

In the first step for the AI application to accomplish our aim, we have developed a prototype of the expert system for the transport of radioactive materials, which can be often used on our jobs and which would enable to be built as a standalone system. This paper presents the prototype of the expert system for the transport of radioactive materials.

DEVELOPMENT BACKGROUND

Under the Japanese regulations, the concept of "transport" includes not only the movement of radioactive materials but also the design, fabrication and maintenance of packagings, and the preparation, consigning, handling, carriage, storage in transit and

receipt at final destination of packages. In the case of the transport of radioactive materials, the staff of radiation safety control should interpret and judge either radioisotope(RI) or nuclear fuel material, the type of the packagings, the labellings and the number of labels on the activity limits from input information of radionuclide, activity, physical state of radioactive material to be transported. Hence, even the well-experienced staff might not interpret and judge the type of the packages and the packagings quickly because the activity limits are given for the special form and other form of radioactive material. Moreover, in the case of two or more nuclides, it will be much more difficult to interpret and judge on the possible combination of radioactivities to be allowed for the transportation with the limited packaging. Accordingly, the objectives of the development of the expert system are to achieve the improvement of rationalization, uniformity and reliability in the interpretations and judgments for the transport of radioactive materials, and to build one of the data bases so that it will be able to be used in the advanced radiation monitoring system.

SYSTEM ARCHITECTURE

The system consists of the following computer hardware and software.

- Hardware : Sun 3/260
- Operating system : UNIX
- Programming language : Lucid Common Lisp
- Knowledge engineering tool : KEE 3.1
- Size of the system : around 1,000 units

KNOWLEDGE BASE (KB)

The system consists of the RADIONUCLIDE-KB which holds common information of radioactive materials for the system and the TRANSPORT-KB which holds information of procedures for the transport of radioactive materials. These KBs are managed by the KEE knowledge base management system.

1. RADIONUCLIDE-KB

The RADIONUCLIDE-KB has the physical knowledge which includes the activity limits of A₁ for special form and A₂ for other form of radioactive materials permitted in a type A package, half lives, types of emitters, and atomic numbers of RI and nuclear fuel material described in the regulations. These knowledges are represented in a frame called an unit in the KEE system. The frame is made from about 400 units. The RADIONUCLIDE-KB is built so that it is possible to add various standard values referred in the regulations such as the derived air concentrations (DAC), the surface density limits, etc..

2. TRANSPORT-KB

The TRANSPORT-KB consists of the rules for the transport of radioactive materials, the interface frames and the record of

transported radioactive materials. The frame is made from about 300 units. These rules provide the following functions for interpretation and judgment.

- (a) Judgment on either RI or Nuclear Fuel Material.
- (b) Judgment on either Low Specific Activity Material(LSA), Surface Contaminated Object(SCO) or Others.
- (c) Calculation of Activity.
- (d) Judgment on the Packages and the Packagings.
- (e) Diagnosis of Conformity of the Packagings.
- (f) Judgment on Transportable Activities.

USER INTERFACE

User interface is composed of the powerful graphics display, on which each slot is attached directly to the graphic image, and various mouse menus so that we can easily operate the system.

SUBSYSTEM IN USE

In the system the "production rules" (rules in an "IF-THEN" format in KEE's inference functions) and the user-defined Lisp functions which are called "method" are adopted. The subsystems to judge mainly the type of the packages by using the reasoning methods are detailed below and shown in Fig.1.

1. Judgment on the Packages and the Packagings

All information required for the reasoning such as radionuclides, activities, states and conveyances of the radioactive material to be transported are given through the dialogue type of interface by a mouse or a keyboard. After the input of these information, the system will judge the type of the packages and the packagings, the labellings and the number of labels by activating KEE's inference engine, i.e., the forward chaining method.

2. Diagnosis of Conformity of the Packagings

The system will judge whether or not the radioactive material is transportable with the packagings by given information such as the above transport factors. The backward chaining methods (see Fig.1) is applied to this reasoning method in the KEE's inference engine.

3. Judgment on Transportable Activities

When there are several radionuclides at the transport planning and when we want to know the transportable activity of each radionuclide with own packagings, there will be following two problems to be solved in connection with these situations; 1) a lot of solutions will exist, 2) it will be difficult for a computer to solve some scheduling problems in reasonable time without an appropriate methods because of the restriction by the memory capacity. The system has the functions to explore the hypothetical situations and to pick up the suitable combination. The rules in Lisp language in the subsystem include an intelligent back-track mechanism to generate solutions quickly. The system has the

inference function made from about 60 functions defined by users, and derives the appropriate combinations of transportable radionuclides. The restriction of exploration is placed on the transportable activity of each radionuclide and the activity ratio which means the ratio of the quantity of the transported radioactive material to the activity limit(A₁,A₂). The solution can be to get the combination so that the sum of the activity ratios is less than 1/1000 or 1 according to the type L or A, respectively.

CONCLUSION

Subsystems, "Judgment on the Packages and the Packagings" and "Diagnosis of Conformity of the Packagings", have brought the improvements on the rationalization, the uniformity, and the reliability for our interpretations and judgments on the preparation of the transport of radioactive materials. Too much time had been spent to interpret and judge transportable activities for each radionuclide before the system was developed. The new system, however, has contributed to reduce the time spent for our judgment. Based on the experiences of the development of the system, we will build the advanced radiation monitoring system to provide for support of our interpretations and judgments on radiation safety control from the design stage to the normal and abnormal operation stage of nuclear facilities.

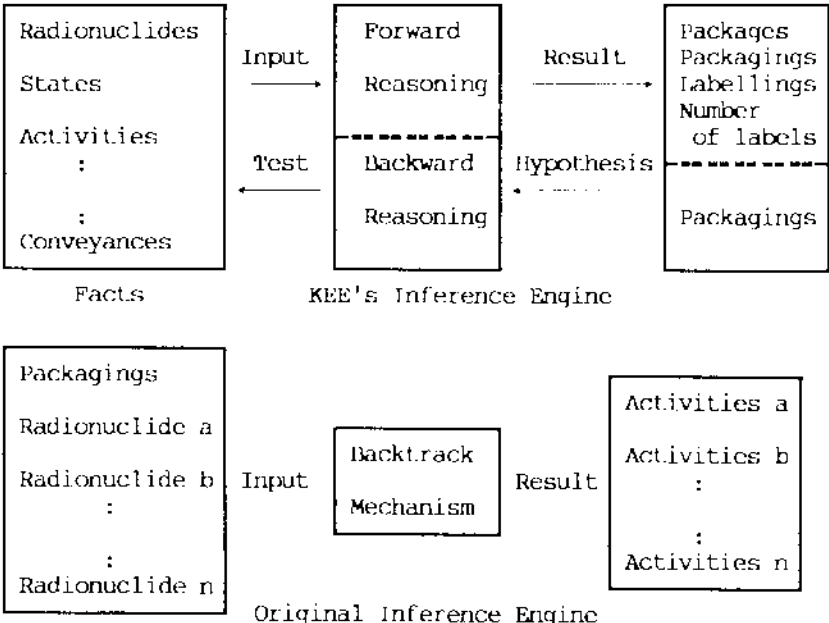

Fig.1 The process to judge the requirements for the transport of radioactive materials

SECURITE ET MANAGEMENT.

Alain MOREAU

Assistant Communication.
Direction du Centre d'Etudes de Saclay.
CEA - FRANCE.

SECURITY AND MANAGEMENT.

Summary : All the studies performed about accident causes have emphasized the influence of Human Factors in the field of Safety and Radiological Protection.

Human actions cannot be understood but also improved without exploring the enormous field of mental representations and emotions, therefore, all the sources of comportments.

Among a working group, safety can be the field of all the comportments relative to this group : relationship with work and between persons.

This leads to management questions. There is no a specific management for the safety. It must be include in the general management policy.

Pedagogy must consider this fact for the training of workers.

INTRODUCTION

Les accidents industriels majeurs ont souligné l'importance du "facteur humain" dans le domaine de la Sûreté et de la Sécurité.

L'analyse des causes d'erreurs a conduit à la réflexion sur les interfaces matériels homme-machine, aux études d'ergonomie des salles de commande et de présentation des informations.

L'attention est portée également aux questions de fatigue, de surcharge de travail, de surmenage... aux éléments physiologiques.

La dimension humaine n'en est pas pour autant réglée. En effet, les actions humaines, les comportements, ne peuvent se comprendre et, éventuellement évoluer, sans que soit exploré le vaste domaine des représentations mentales et des émotions.

Le monde de l'émotion est abordé dans l'analyse des phénomènes opposés et complémentaires de l'accoutumance aux risques d'une part, et de rumeur et de panique d'autre part.

L'émotion conduit, en fait, tous les actes qui apparaissent incompréhensibles sur le plan de la logique objective, sur le plan de la raison, qui apparaissent "irrationnels".

Il reste à trouver les origines de l'attitude ainsi qualifiée si on veut lui apporter un remède efficace.

Nous en venons alors, puisque nous nous trouvons dans un collectif de travail, à rejoindre les questions de **management** et, pour cela, à porter attention aux mécanismes humains fondamentaux.

LE PHENOMENE DE L'EMOTION

L'émotion fondamentale est l'émotion peur **qui est particulièrement présente dans le domaine du risque radiologique.**

Il y a d'autres émotions que l'émotion peur. Toutes sont liées à la satisfaction ou à la non satisfaction des **aspiration fondamentales** que l'on classe en trois grandes catégories :

- * se sentir en sécurité. C'est l'aspiration première : exister, dans notre intégrité.
- * avoir une activité qui ait un sens, dont nous connaissons et acceptons la finalité.
- * être intégré et libre au sein d'une collectivité. Y avoir notre part de pouvoir.

On les appelle aspirations fondamentales parce qu'il ne peut pas ne pas y avoir malaise si l'une d'entre elles n'est pas, pour l'intéressé, et selon son point de vue satisfaite.

Un malaise lié à une insatisfaction ne peut pas ne pas s'exprimer.

Le domaine de la sécurité, qui est le domaine de base se rapportant à la relation au corps et à nous-même est le domaine privilégié d'expression sous la forme de la maladresse, de l'erreur, du comportement inadapté, et, à la limite, de l'accident.

On peut y voir, selon les cas :

- un appel, une demande d'attention,
- un mécanisme d'auto-punition lié au sentiment de ne pas avoir répondu à ses exigences de responsabilité (ou sentiment de culpabilité),
- un besoin de recherche des limites personnelles par la confrontation avec le danger afin de compenser le sentiment d'ennui ou d'enfermement.

Tchernobyl a été décrit, sur le plan des erreurs humaines, comme une conséquence de l'"incurie", de l'"irresponsabilité" et de l'"indiscipline". C'est une illustration à l'extrême des relations entre les comportements humains et les dysfonctionnements sur les plans de la relation au travail et des relations dans la collectivité de travail, autrement dit, du Management.

LA FORMATION EST LIEU D'EXPRESSION.

Une formation à la sécurité ne s'adresse pas uniquement au savoir comme peut le faire une formation technique ou scientifique en physique ou en chimie. C'est-à-dire qu'elle ne concerne pas uniquement la mémorisation de concepts puisqu'elle se donne pour objectif fondamental d'influer sur les comportements.

La formation doit utiliser la méthode dite active, celle qui adopte une démarche centrée sur les stagiaires, partant de leur situation, de leur point de vue, en développant l'aspect concret de leur existence, permettant leur expression.

C'est cette expression verbale qui doit limiter la nécessité du recours inconscient à l'expression comportementale.

D'autre part, c'est lorsque l'expression, l'échange, sont conduits au sein du groupe de travail que peuvent apparaître des changements dans les systèmes de valeur et comportements désignés par la notion de "culture de groupe" directement liée au domaine du Management.

LE MANAGEMENT ET LA SECURITE VONT DE PAIRE

Expression, mise en relation des personnes entre elles, élaboration collective, dynamique d'évolution, sont des notions qui se rapportent à la fois au domaine de la sécurité et au domaine du management des ressources humaines, du management participatif et de la communication dans l'entreprise.

De même que la sécurité peut être le domaine d'expression comportementale de tous les thèmes relatifs au milieu de travail, elle peut être le domaine d'expression verbale dans lequel les personnes se sentent autorisées à décharger leurs tensions ou, à contrario, dans lequel les personnes peuvent recommencer à entrer en communication.

Bref, la sécurité **est** outil de management. Il n'y a pas de management de la sécurité sans management tout court. Réciproquement, tout management à démarche participative qui veut privilégier l'établissement de communications, c'est-à-dire d'échanges entre les personnes, en se centrant sur la satisfaction de celles-ci, ne peut pas ne pas s'appuyer sur la sécurité en tant que base, assise de la démarche.

Tout est lié : la sécurité n'est pas seulement un "indicateur" de la qualité des autres éléments de la situation

de travail : motivation au travail et climat social. La sécurité est un **outil de management** et un **outil de communication**.

Réciproquement, l'écoute, la formation active, la communication, le management sont fondamentalement des outils de sécurité, des outils de sécurité radiologique en particulier, domaine si privilégié des expressions émotionnelles comme l'ont montré les événements de cette dernière période.

ORIENTATION BIBLIOGRAPHIQUE

Concernant :

- La fiabilité humaine, l'erreur humaine, le facteur humain :
Vademecum Qualité - Sécurité.
ASSOCIATION QUALITE-SECURITE (AQS)
16, résidence du Parc - 91300 MASSY.
- Les actes manqués :
S. FREUD - Psychopathologie de la vie quotidienne.
Petite Bibliothèque Payot.
- Les aspirations fondamentales de la personne :
KARLFRIED GRAF DURCKHEIM - L'homme et sa double origine.
CERF.
- L'animation de groupe :
CARL R. ROGERS - Le développement de la personne. -
DUNOD

**STANDARDIZED RADIOLOGICAL HAZARD ANALYSIS
FOR A BROAD BASED OPERATIONAL SAFETY PROGRAM**

W. Wadman III¹ and L. Andrews²
Health and Safety Division
Los Alamos National Laboratory (LANL)
Los Alamos, New Mexico

ABSTRACT

The Radiological Hazard Analysis (RHA) Manual provides a methodology and detailed guidance for systematic analysis of radiological hazards over a broad spectrum of program functions, housed in a wide variety of facilities. Radiological programs at LANL include: research and experimentation; routine materials operations; production; non-destructive examination or testing; isotope and machine produced radiations; chemistry; and metallurgy. The RHA permits uniform evaluation of hazard types over a range of several orders of magnitude of hazard severity. The results are used to estimate risk, evaluate types and level of resource allocations, identify deficiencies, and plan corrective actions for safe working environments.

INTRODUCTION

Laboratories within the U.S. Department of Energy are undergoing significant changes in the manner by which they conduct operations. Operational Health Physics groups are not an exception. With budgetary constraints becoming more severe, staffing and resources strained or severely limited, methods had to be devised to provide equal or better service in spite of the hardships. Standardization of the methodology and consistency of evaluating the types and levels of radiological hazards involving several hundred projects in over 150 facilities, spread over 43 square miles, was essential for the operational Health Physics personnel. The Standardized Radiological Hazard Analysis Manual was determined to be one of several practical working tools for Health Physicists in the field. The 300 page manual starts with a detailed index from which an analysis plan is constructed. Once in the field, the use of the manual index provides ready access to guidance, assessment details, and forms for other hazards or issues that were either unexpected or not obvious during the initial assessment. The guidance contained in the manual is detailed, but allows for independent input by each Health physicist that uses it. The training on the use of the RHA Manual emphasizes that the guidance should be used as a tool to direct and focus analysis thought processes, but should not limit the RHA performance to merely a check list task.

Data from the detailed Radiological Hazard Analysis report sheets is subsequently input to a commercially available relational database which is both an analysis tool and the database for each and every facility for which a Radiological Hazard Analysis has been performed.

Blank pages of forms and reports are obtained from stock to replace those used from the binder to be ready for the next facility analysis.

DEVELOPMENT OF THE RHA MANUAL

There are existing methodologies for risk assessments of specific processes, and a few for multi-function facilities. The Nevada Operations Office of the DOE produced the 150 page "Radiological Safety Functional Appraisal and Program Review Guide," in 1990. (Do90) This has direct application to DOE/NVO facilities. It is based upon a radiological environmental program. A method for determining hazard classifications of DOE facilities was developed at Battelle PNL (Lu91). The hazard classification required a walkthrough by an inspection team of persons with considerable expertise in the various disciplines. More than one DOE Operations Office required the technique to be used by operating contractors of DOE facilities, to determine gross hazard classification values for their facilities. These determinations were not sufficiently in-depth to provide the level of detail LANL felt to be necessary for our operational hazard evaluations. The technique also did not provide useful data regarding operational hazards routinely faced by facility operations personnel, or health and safety support personnel.

The concept of the Standardized Radiological Hazard Analysis Manual was originated by one of the authors (LA). With access to a consultant with a broad spectrum of "hands-on" experience in the field of Health Physics, Industrial Hygiene, and Radiological Environmental Monitoring Programs, the project was undertaken.

The manual was conceived as a light-weight, notepad-sized document with outline formatted "reminders" for review while doing field facility walk-throughs. The document is now about 300 single side printed pages, maintained in a three inch thick binder, and requires training in its use to provide familiarity and a reasonable level of surety that it will be used uniformly by the trained staff.

Each type of radiological facility or operation was considered as an independent unit during the drafting of the RHA Manual. Details from observations, physical measurements, radiological measurements, locations of components, and similar pertinent data, are called out in the text of each hazard analysis section. In the initial draft, in both the manual and the software, each hazardous item was separate, as was each mitigation process, and was considered only for that room, building, or process. Subsequently, common items, such as glove boxes, filtrations, detection and alarm systems, were coded in the relational database software. This served to provide more rapid input, reduction in errors, and conservation of RAM and storage required by the computer program.

Hazard levels, risk assessments and hazard mitigating equipment or engineered features are analyzed in the software. All values obtained from the analytical results, relate to hazards present during normal operational circumstances. No attempt has been made to extend the analysis into accident scenarios. With the availability of information regarding radionuclides, inventory on hand, physical and/or chemical form, and details of the

monitoring systems, and ventilation systems, assessing limited accident scenarios remains a possibility.

Each developmental iteration has only expanded the size of the overall program, both software and Manual. Some future consideration may be to purchase the relational database "engine", and write the specific RHA database applications program. Several advantages would be, easier commercial or public domain releases of the software component which could save 50% of the RAM occupied by features that are not used from the standard database product. Time savings could be realized by having direct page access to pertinent input requirements, rather than have to page through irrelevant subject matter to arrive at the appropriate page for the next input.

TYPES OF FACILITIES INCLUDED

The RHA Manual is designed to be used to evaluate radiological hazards associated with the following programmatic elements:

Research and Experimentation: explosion dynamics; armor, anti-armor; criticality; weapons enhancement; controlled thermonuclear reactions; free electron lasers,
Routine Operations: reactor operations; radioactive waste management; weapons production related operations; weapons testing operations; retirement storage operations,
Production: quality control; materials purity; lathe and milling shop operations; purification; enrichment; weapons related activities; medical aspects of LAMPF operations; X-ray crystallography confirmations,
Non-Destructive Examination or Testing: fixed X-Ray radiographic facilities; fixed facility Van de Graaf radiography; high speed x-ray of explosive events; portable radiographic unit safety; eddy current testing of radioactive materials; magnaflux testing of radioactive materials; betatron narrow beam, thick target radiography,
Isotope Produced Radiations: calibrations; sealed source radiography; activated accelerator component radiological protection; heat source radiological protection; incidental weapons component exposure control; weapons debris analysis; reactor fuel processing hot cell operations,
Machine Produced Radiations: Los Alamos Meson Physics Facility; IBF tandem Van de Graaf; single stage Van de Graaf; free electron laser; plasma focus devices; pulsed power conversion; health center x-rays; neutron generator facility; electron guns; ion implantation,
Chemistry: analytical; alloy; quality control; quality assurance; medical isotope purification hot cell operations,
Metallurgy: analytical; developmental; design improvement; stability improvement; yield improvement; induction heating; laser isotope separation,
Transportation: On-site, inter-area, intra-area, for safety and compliance with State and Federal shipping requirements on public roads,
Compliance Assessment: Confirm compliance with Health and Safety

requirements imposed by all applicable State, Federal Agency requirements, laws, DOE Orders.

In the above 10 major areas, each of the 56 categories of operation, project, or facility has its own set of RHA forms. Each analysis must be independent in-so-far that it is not a component of a larger complex. If the latter is the case, the RHA forms are grouped into a facility package. The results of the full analysis of the units as a system will result in a different hazard rating because of the concurrent and dependent mode of operation.

CONCLUSIONS

Present operating facility inspections are performed with a perspective focused on the problem of immediate concern. The use of the RHA Manual will provide consistency for such evaluations. Performing full facility radiological hazards analyses will accomplish several objectives: Advance knowledge of the facility's or operation's hazards; provide a global perspective of concurrent but unrelated hazards of adjacent operations; consistent or uniform approach to evaluations and solutions; applications of "lessons learned"; greater confidence to younger professionals in the Health Physics Groups; a cross-training tool for professionals and technicians not familiar with areas outside of their duty areas; a computerized database with rapid access for rapid retrieval for the line organization, security, fire, and emergency response teams. Two peripheral uses of the RHA Manual may be:

1. The RHA may have use as a formal tool during the drafting of facility Safety Analysis Reports (SAR) and Updated Safety Analysis Reports (USAR).
2. There may be some value in training the facility supervision to use the system, to provide them with the capability to perform more frequent reviews of their facilities than can the limited staff of operational Health Physicists. This is beneficial for the Laboratory through the heightened awareness for radiological hazards in the workplace.

¹ Private Consultant to LANL. ² LANL HS-12 Health Physicist

REFERENCES

Do90 U.S. Department of Energy, Nevada Operations Office, Environmental Compliance Branch, Environmental Protection Division, Las Vegas, Nevada. "Radiological Safety Functional Appraisal and Program Review Guide". (1990)

Lu91 Lucas, D.E., A Practical Approach to Hazard Classification, Rev 1., Battelle, Pacific Northwest Laboratories, Richland, Washington. March 1991.

This work was performed under the auspices of the University of California operated Los Alamos National Laboratory.

L'OPTIMISATION DE LA RADIOPROTECTION
SUR LE SITE DE MARCOULE

A. CLECH, A. DEVITA, Service de Protection
contre les Rayonnements - Etablissement COGEMA MARCOULE

OPTIMIZATION OF RADIATION PROTECTION
ON THE MARCOULE SITE

This paper presents the mean and methods used to optimise the exposure of workers mainly during maintenance and breakdown operations. The evolution during the ten last past years of the collective and the average annual dose per worker show the efficiency of the method.

I - INTRODUCTION

Le Site de Marcoule regroupe des installations nucléaires à vocations multiples :

- un réacteur à neutrons rapides Phénix,
- un atelier pilote de traitement de combustibles irradiés avec ses laboratoires de recherche,
- une usine de retraitement de combustibles irradiés graphite gaz.

Ces installations sont exploitées soit par le CEA soit par la COGEMA. Pour assumer leur responsabilité en matière de radioprotection, les deux directeurs de ces entités sont assistés par un Service de Protection contre les Rayonnements (SPR) dont les missions sont principalement l'assistance conseil en matière de prévention, le contrôle et la surveillance des nuisances radiologiques dans les installations et l'environnement du Site.

L'expérience montre que la plus grande partie des doses reçues par le personnel est liée aux opérations d'intervention (maintenance préventive ou corrective, intervention d'urgence) qui sont communément appelées "chantiers".

Dans cet exposé nous présentons plus particulièrement les actions que nous avons développées pour optimiser et limiter l'exposition des intervenants.

II - OBJECTIFS VISES

Dans notre démarche d'optimisation et de limitation des expositions nous visons les objectifs suivants :

- Mettre tout en oeuvre pour que l'exposition interne reste toujours la plus faible possible (si possible nulle) et soit donc négligeable devant l'exposition externe.
- En matière d'exposition externe notre objectif est de réduire au maximum l'exposition collective, de limiter l'exposition des personnels les plus exposés (notre valeur guide est de limiter l'exposition individuelle à 15 mSv/an), de limiter le nombre de personnes ayant des doses supérieures à 10 mSv/an et par conséquent d'avoir une dose moyenne individuelle faible.

III - ACTIONS DANS LE DOMAINE DES INTERVENTIONS

Pour atteindre notre objectif, sur les chantiers notre action s'exerce principalement sur:

- la préparation de l'intervention à l'aide de la fiche de travail en milieu radioactif (FTMR),
- le suivi permanent en temps réel des expositions à l'aide d'un dosimètre opérationnel à lecture automatisée associé à une gestion informatisée des doses,

III.1 LA FICHE DE TRAVAIL EN MILIEU RADIOACTIF (FTMR)

Il y a établissement d'une FTMR (Fiche de Travail en Milieu Radioactif) chaque fois que le niveau prévisible d'exposition des agents participant à un chantier est supérieur à un seuil, elle décrit :

- le chantier (avec éventuellement son mode opératoire détaillé d'intervention),
- l'état radiologique de la zone,
- les protections individuelles nécessaires,
- l'exposition provisionnelle (collective et individuelle),
- la liste nominative des intervenants.

III.2 LA DOSIMETRIE OPERATIONNELLE

Cette dosimétrie ne se substitue pas à la dosimétrie légale. Elle est effectuée par des stylos dosimètres utilisables :

- par les opérateurs, leur indiquant continuellement leur dose.
- Par la radioprotection pour piloter les doses individuelles et les coûts radiologiques.

Au niveau local (dans chaque installation) des lecteurs de stylos dosimètres permettent d'associer à un agent la dose intégrée. Au niveau central, un système informatisé calcule et gère les doses des différents lecteurs (Il y a en moyenne 25 000 mesures par mois).

III.3. LE SUIVI OPERATIONNEL DU CHANTIER

Pendant toute la durée du chantier le suivi de l'exposition est effectuée de la manière suivante:

- Sur le lieu même de l'intervention, une feuille permet de recenser les agents et ils doivent y inscrire leur dose journalière.
- Chaque étape de l'intervention est décrite (personnel intervenant, protections individuelles, doses intégrées, renseignements d'ordre radiologique) sur un cahier de zone.
- Chaque jour les agents de radioprotection s'assurent que la dose indiquée sur la feuille du chantier correspond à celle enregistré informatiquement.

- Périodiquement (suivant l'importance du chantier) un bilan est effectué afin de s'assurer que l'objectif (bilan dosimétrique) sera respecté, ce bilan est réalisé à partir des terminaux disposés dans chaque installation et reliés au système central informatisé. On peut consulter les doses d'un individu isolé ou d'un groupe d'individus définis par l'opérateur.

IV - LA GESTION PREVISIONNELLE DES DOSES INDIVIDUELLES LES PLUS ELEVÉES

Dès le dépassement d'un seuil d'intégration (12 mSv/12 mois glissants), un suivi particulier des doses est mis en place. Le responsable de la radioprotection et l'encadrement de l'intervenant établissent une prévision d'intégration stylo mois par mois afin de ne pas dépasser les 15 mSv/an.

Cette prévision se traduit par un examen détaillé des opérations auxquelles peut participer l'intervenant, et, son affectation préférentielle à celles qui présentent le minimum d'exposition potentielle.

V - CONCLUSION

La mise en application de cette méthode de travail a permis de maîtriser et réduire au fil des années l'exposition des personnels malgré le vieillissement des installations qui a nécessité d'effectuer des chantiers importants de rénovation qui sont sources d'exposition.

Sur les figures 1, 2 et 3 sont représentées les évolutions sur 10 ans de l'exposition globale, qui a baissée d'un facteur 2,5, de la dose moyenne annuelle par agent qui a été réduite d'un facteur 3 et le nombre d'agents ayant subi une exposition annuelle supérieure à 10 mSv/an qui est passé de 200 à 10.

Il faut aussi signaler que tous les dossiers d'intervention sont archivés et sont utilisés en retour d'expérience pour la préparation des interventions futures.

Figure 1 : Evolution de la dose totale de l'établissement de Marcoule (HmSv)

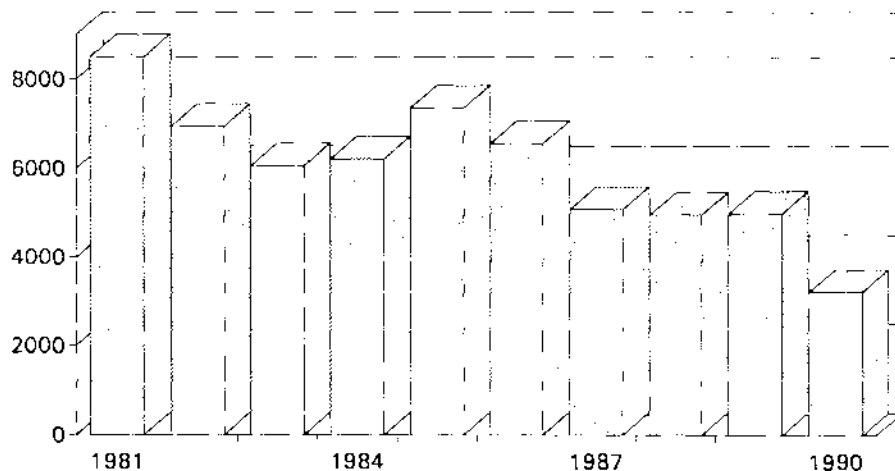

Figure 2 : Evolution de la dose moyenne annuelle par agent (mSv)

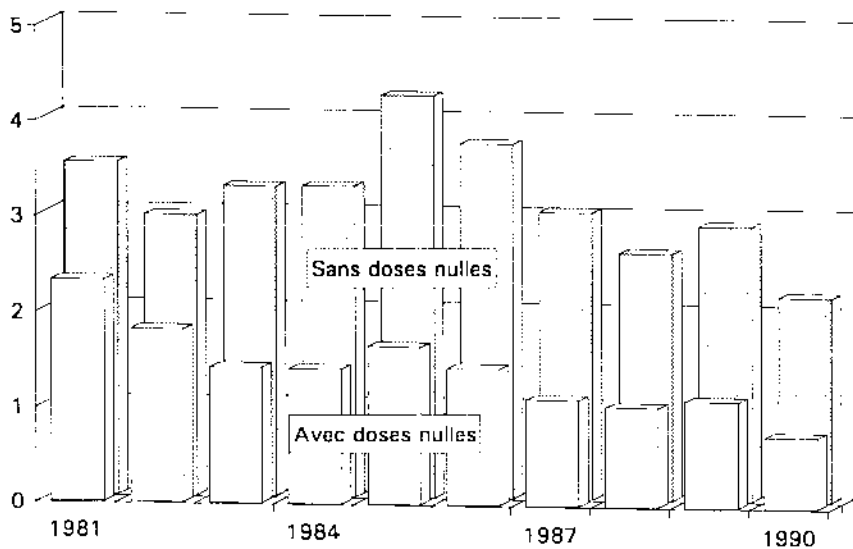
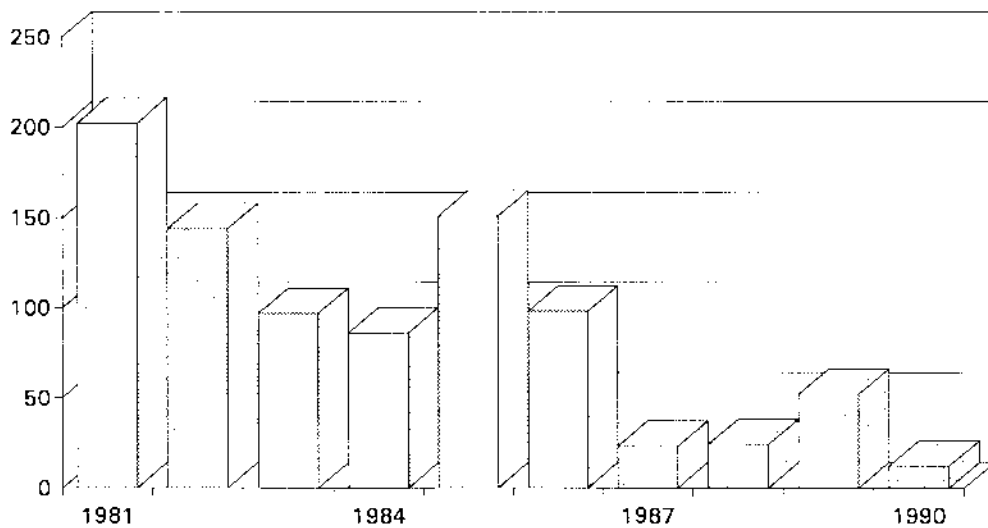

Figure 3 : Evolution du nombre d'agents ayant une dose annuelle supérieure à 10 mSv



REMOTE OPERATIONS AND ROBOTS IN NUCLEAR POWER PLANTS-OUT LOOK AND REALITIES

JEZEQUEL Patrick - ELECTRICITE DE FRANCE

Résumé : Ce document, tout en rappelant les différents domaines actuels et potentiels d'utilisation des robots, propose une démarche de développement dans ce domaine.

ABSTRACT

This document propose to discover why the robotic discipline has not become an integral part of current maintenance procedure, and shows some areas to be improved and tested. It provides the different topics, where safety on workers and population could be improved by using robots and the means to reach this goal.

INTRODUCTION

Remote operation and robotics techniques were introduced into French nuclear power plants at the most seven years ago, particularly with the pilot repair of internal core structures in the CHINON A3 G.G.C.R. system, christened the I.S.I.S. Since then, E.D.F.'s operational and research sectors have been organized to officially encompass the notion of "robotics" development. However, these sectors remain somewhat on the fringe with respect to the overall development of equipment. The concept proposed i.e. that of robots or remote tools, often provides an alternative to the set, but much more dedicated notion of the "*special machine*". In the case of robots or remote tools, their versatility, both with regards to the tools used and to programming of a given task, offers the definite functional advantage of a large range of potential applications, but poses an organizational problem if they are to become directly operational.

The complexity of the system created also increases the level of training required, with regards to both control and maintenance.

This brings us to the crux of the problem : is the alternative a necessity in the unavoidable terms of technical means, safety and (or) cost ?

I DIFFERENT ASPECTS OF SAFETY

A) Aspects concerning the active population of nuclear power plants

These aspects stem from two basic problems :

- *the reduced accessibility of components :*

this first restriction, imposed by the question of accessibility, induces man to explore ways of remote intervention, which does not necessarily mean remote operation or robotics, since the tools used can be specific to a task and a given component (example : micro- mechanics).

- *dose rates* :

this aspect means that the designer must find a compromise between the development of remote working methods and duplication of the same tasks by an increasing number of personnel. The factors to be considered here are collective dosimetry and individual dosimetry. The solution will be optimized from this point of view by use of the ALARA method. In certain cases, analysis is rapid and remote controlled intervention is necessary (fuel).

The following fields come into play during the lifetime of a power plant :

1) Normal maintenance

This depends on the three complementary notions of productivity, safety and speciality. A typical example is that of steam generators, where control and maintenance (of tubes) are often dissociated, but where there is an increasing harmonization of the means being developed to solve the problems involved. The current aspects of dosimetry inside steam generators has led both operators and manufacturers to study the solution of robots and truly multi-task remote manipulators which have direct access from outside the water bowl. At the same time, safety will necessarily be reinforced by the need to use computer-based tools to memorize the work carried out (where, when, how).

2) Incidents

Incident-related phases are based on the assumption that a stable state of the system will be rapidly achieved. The robotics aspect must always be compared with the human aspects of intervention (rapidity, competence, physical potential). When it comes to the question of "*mobility*", robotics is currently slow to be implemented ; on the other hand, the "*remote operation*" aspect can offer a long term solution. Structures which facilitate logistics and communications (standby and backup facilities, tracks, maintenance networks, etc...) in order to solve the problems of rapidity, accessibility and communication (reduction of wiring times, etc...) could be discussed.

3) Dismantling

Remote operation methods are definitely a potential aid for the implementation of special machines which could work for long hours in a given place (transport aspect) or for direct work on components when the latter require particular skill and a degree of adaptability which cannot be either programmed or modelized beforehand.

B) Workers and the surrounding population - Accidents

The accident related situation covers two aspects :

- the immediate intervention solution which supposes both rapid organization and special means of intervention (aimed at protecting people and providing maximum confinement),
- maintaining and then going back to a specific configuration, which supposes appropriate logistics and on-going work carried out on a long-term basis.

Potential solutions have unfortunately been tested with varying degrees of success at CHERNOBYL and T.M.I.

With regards to intervention which is both internal and external to the reactor building, mobile land and air vehicles of the remote operated type and manipulator arms must be developed on a transborder level and with an exchange potential in mind.

This means, in particular, that it is possible to envisage the creation or reinforcement of structures :

- on a technological transborder level (eg. standardization, telecommunications),
- on a trans "orderer" level (eg. civil safety, armament, nuclear, space),
- on a financial level (industrial consortiums, insurance pools) in order to facilitate the development of appropriate means to separate budget-related aspects concerning normal maintenance from those concerning "risk-related" developments.

II POTENTIAL ACTION

A) Techniques

1) Means of analysis

It is essential that the following computer type analysis tools be developed or adapted to nuclear power plants :

- value analysis,
- simulation C.A.D.,
- definition of specifications and organization (eg. S.A.D.T.),
- analysis/dosimetric reports (eg. DOSIANA - DOSIECO, C.E.P.N. software).

Or of the physical type :

- benchmark and performance tests,
- on-line telediagnosics for maintenance and troubleshooting,
- reliability studies.

2) Improvement of logistics

3) Feedback on the design of new power plants

The integration of robotics can be envisaged :

- with regards to the actual design and construction of power plants, in so far as productivity is concerned (modularity, manufacturing control). This would facilitate the design of machinery to be used during the maintenance and development phases,
- with regards to the integration of standby facilities in proximity to components, thus facilitating maintenance work.

B) Structures and organizations

1) Standardization/training

2) Information networks

3) Consortium for reflection on future development

CONCLUSION

We saw above that many points remain to be studied and defined to quantify the real potential benefit of the robot or remote operation in the nuclear field.

There are two levels to be considered :

- 1) The Designer : Should be solve the problem in termes of a specially dedicated machine, a programmed robot with a certain modularity and versality or from a remote operated approach ?
- 2) The User : What is the best quality service and what motivation is there, given that robots turn operators into simple supervisors whereas remote operation necessitates a specific know-how of normally manual tasks ?

One could also ask, as concerns recent mixed (robot and remote-operated) instrumentation and control modes, if it is fruit of a purely technical nature or express desire to keep man's initiative computerized aid rather than a tailor-made pushbutton approach.

BIBLIOGRAPHIE

Working Material I.A.E.A. Safety Implications of plant automation and robotics. Report Vienna, 11-15 November 1991.

Internationnal workshop on new developments in occupational dose control and ALARA implementation at N.P.P.S. and similar facilities. Brookhaven Laboratory NY.11973, september 18,21 1989. "An ALARA approach for robotics and remote tooling evaluation in nuclear power plants" C. LEFAURE, J. LOCHARD, J. SEGUY.

VENTILEX
Un système expert en ventilation nucléaire

C. Roussel & D. Soulatges
CEA/Institut de Protection et de Sûreté Nucléaire
BP n°6 - 92265 Fontenay-aux-Roses Cedex
France

VENTILEX
An Expert System on Nuclear Ventilation

VENTILEX provides a computer help for safety analysis of nuclear plants ventilation systems. It uses knowledge on nuclear ventilation regulation and on the state of the art. Data relative to rooms, process and draft of the ventilation system are taken into account. Conformity of the user's solution with safety and protection principles is checked. Particular points are recognized and memorized when justifications are needed. All conclusions of the system are updated when inputs are modified. Using VENTILEX would facilitate the dialogue between safety analysts and nuclear plants conceptors.

1. Introduction.

La ventilation d'une installation nucléaire a des fonctions de confinement, d'épuration, de surveillance, d'assainissement, de conditionnement et de confort. Les cinq premières sont des fonctions de sûreté qu'un système de ventilation nucléaire doit assurer aussi bien que possible. Le concepteur de l'installation est tenu de présenter successivement aux autorités de sûreté les rapports préliminaire, provisoire puis définitif de sûreté.

1.1. Le rapport préliminaire de sûreté.

Le rapport préliminaire de sûreté rappelle les données relatives au génie civil de l'installation, au procédé industriel ainsi que les objectifs de sûreté. L'installation est considérée comme un ensemble de locaux avec leurs liaisons réciproques. Le terme source de chaque nuisance et les contraintes d'accès en personnel pour l'exploitation, la maintenance et l'intervention sont pris en compte pour chaque local. Les moyens qui seront mis en oeuvre pour atteindre ces objectifs de sûreté sont exposés. Il ne s'agit pas encore d'un schéma précis du système de ventilation, toutefois, l'ordonnement des flux de ventilation et le dimensionnement des circuits sont déjà déterminés. Les points qui devront faire l'objet d'une démonstration par un calcul complémentaire d'aérodynamique sont identifiés.

1.2. Le rapport provisoire de sûreté.

Après acceptation du rapport préliminaire, le concepteur détermine le routage précis des conduits et le choix des composants. Cette tâche peut en partie bénéficier du recours à des programmes de conception assistée par ordinateur.

1.3 Le rapport définitif de sûreté.

Le rapport définitif de sûreté doit démontrer que le système de ventilation réalisé permet bien d'atteindre les objectifs fixés dans les précédents rapports.

1.4. Utilisation de VENTILEX.

VENTILEX est doté de connaissances permanentes sur la réglementation et l'état de l'art en ventilation nucléaire. Ces connaissances sont issues du manuel de référence [Réf. 1] et du jugement d'experts.

L'utilisateur fournit des données disponibles sur l'installation, issues du génie civil et du livre de procédé, devant figurer dans le rapport préliminaire de sûreté. Les solutions, entrées sous la forme d'un schéma de principe, sont évaluées. L'utilisation de VENTILEX va ainsi de la conception du rapport préliminaire de sûreté jusqu'au seuil de l'utilisation des programmes d'aérodynamique et de conception assistée par ordinateur.

2. Description.

VENTILEX utilise deux écrans de travail. Le premier permet la saisie et la vérification des données relatives au génie civil et au procédé. Le second permet la saisie des composants et de la structure du réseau de ventilation ainsi que l'accès aux modes d'évaluation du réseau dans ses diverses configurations.

2.1. Ecran Installation.

Trois écrans présentent côte-à-côte la fiche complète relative au local choisi par l'utilisateur, une fiche de liaison entre ce local et un autre, au choix parmi ceux qui sont en liaison avec lui, ainsi que le résumé de la fiche de ce second local.

La cohérence et la conformité des données relatives à chaque local sont vérifiées dès leur saisie. Cette vérification utilise un système expert d'environ 300 règles. Pour chaque donnée, le système peut accepter sans réserve, accepter avec un simple avertissement (exemple d'un local à accès permanent avec une température maximale en été légèrement supérieure à 25°C), accepter sous réserve de la fourniture de justifications ultérieures (exemple de dépressions relatives a priori trop proches dans deux locaux mitoyens mais qui pourront être justifiées par un calcul) ou refuser la saisie (il est impossible de déclarer une piscine de stockage contenue dans une boîte à gants ou un réacteur dans une infirmerie).

Les liaisons entre locaux sont des trois types suivants : mitoyens, dessus/dessous et intérieur/extérieur. Elles sont déclarées avec la nature de la paroi, ses ouvertures et leur éventuel mode d'obturation.

2.2. Ecran Ventilation.

Cet écran présente le fichier des locaux restreint au résumé des fiches de local ainsi que le fichier des matériels composant le système de ventilation. Il laisse la plus grande surface de l'écran pour la présentation de schémas partiels du circuit, calculés en fonction de

la nature de la vérification demandée par l'utilisateur.

Chaque matériel peut prendre plusieurs états (marche, arrêt ou panne pour un ventilateur; normal, déchiré ou colmaté pour un filtre; etc...). Il est possible de déclarer des asservissements entre matériels (exemple : si le ventilateur V1 est à l'arrêt alors le registre motorisé R1, s'il n'est pas lui-même en panne, sera fermé). L'utilisateur peut choisir entre trois types de configurations : standard (confinement dynamique assuré), panne de tous les ventilateurs (confinement statique) et configurable par l'utilisateur.

Pour chaque configuration, tous les circuits entrant - ou sortant - du local affiché depuis - ou vers - l'extérieur ou un autre local sont recherchés et tracés. Les niveaux d'épuration pour chaque nuisance (aérosols, iode et tritium), le sens des transferts, les risques de rétrodiffusion et les caractéristiques des matériels en fonction de la nature des flux qui les traversent sont vérifiés. Cette vérification porte, une fois les calculs effectués, sur une quarantaine de règles. La reconnaissance de rétrodiffusions possibles demande que les états résultant de pannes des ventilateurs d'extraction soient étudiés.

3. Conclusion.

La maquette de VENTILEX a d'abord été testée sur des exemples d'école, destinés à mettre son jugement en défaut dans des cas de complexité irréaliste (présence d'aérosols, d'iode et de tritium dans des circuits imbriqués). Elle a également été appliquée sur un exemple issu d'un cas réel d'une taille significative.

Le domaine d'application de ce système peut être étendu par la prise en compte des risques voisins : incendie, gaz explosifs et toxiques chimiques.

Il est possible d'effectuer un couplage avec des codes de calcul existants en aéraulique. Dans ce cas, VENTILEX générerait les jeux de données relatifs aux vérifications numériques qu'il demande. De même, un couplage avec les programmes de conception assistée par ordinateur est possible par la génération d'un fichier de contraintes lisible par ces programmes.

La version opérationnelle de VENTILEX devrait être disponible au cours de l'année 1993.

Référence.

- [1] Manuel de Ventilation des Installations Nucléaires.
Publication PMDS 2^{ème} édition - juillet 1987.

PANTHERE RP : A TOOL FOR PREVISION OF DOSE RATES

BRISSAUD ALAIN RIDOUX PHILIPPE
EDF SEPTEN 12-14 avenue Dutrievoz Villeurbanne 69200

ABSTRACT:

Different tools can be used for the preparation of maintenance. One of them is **PANTHERE RP**: it allows the prediction of dose rates.

RESUME

Différents outils peuvent être utilisés pour la préparation de la maintenance. **PANTHERE RP** est l'un d'eux: il permet de prévoir les débits d'équivalent de dose.

I INTRODUCTION

With the aim to maintain the fair dosimetric results of french nuclear power plants, tools allowing a better preparation of normal and exceptional maintenance are currently developed by EDF. Among these tools, one is "PANTHERE RP" that allows the detailed prediction of dose rates for complex geometries with distributed radioactive sources. These abilities are required to simulate the most frequently encountered situations in NPP.

II COLLECTIVE DOSE (CD)

CD is defined, for a given task, as follow: $CD = DR * WORK VOLUME$
man.Sv SV/unit time MAN.unit time

The simplicity of the formula should not hide the practical difficulties:

- a whole maintenance task is a sum of elementary subtasks,
- a unique DR for a given subtask is indeed a crude approximation,
- feeding sound values of DR and WV is not at all straightforward.

It may be useful to remind that DRs values, job organisation, actions to minimize/optimize DRs should not be considered as independant parameters. To optimize CD, it is of course necessary to minimize both factors DR et WV. Because of the scope of EDF SEPTEN Radiation Protection Group, we have focused on the DR factor.

III PANTHERE RP

The name is an acronym for: " **P**rediction and **T**heoretical **A**nalysis of **E**xposition at **R**eactors for **R**adiation **P**rotection "

The prediction of DRs when a given job will be performed can be obtained by various means: from existing experience (prope or foreign) and from direct measurement. In both cases, one is confronted to the same problem: Dose Rate is a global parameter: you still do not know where it comes from! Anyway, DR measurements cannot be performed in same situations. For example, you cannot measure the dose rate in the axis of a primary pipe before you have cut it

It appears that the best solution is to simulate the dose rate via calculations: this is precisely the aim of PANTHERE RP.

3-1 where does PANTHERE RP come from ?

Softwares to calculate the DR have been developed and used by EDF during the design

stage of nuclear units .

The shifting to the utilization for maintenance (preparation of jobs) has actually begun with the steam replacement at DAMPIERRE 1 .The importance of DR prevision in the overall process of doses prediction has led to further developpments of existing softwares .The resulting product is a linkage between numerous softwares , and has been named PANTHERE RP V0

PANTHERE RP V0 allows :

- to perform DR mapping for complex lay out ,(figures 1)
- to give , for any point where DR is calculated , the contribution of the various parts of the installation ,
- to precise the influence of source composition (isotopes/evolution with time).

3-2 PANTHERE RP AT WORK

PANTHERE RP allows the calculation of DR , starting from a 3 dimensional re-presentation of the geometry and the knowledge of radioactive sources .This repre-sentation is more or less easily obtained wether you can extract it of a computerized mockup or not . In this last case , appropriate softwares of PANTHERE RP help the user to build up the geometry from charts : this construction is interactive .

The computering process can then be performed This step does not need an important participation of the user .The underlying idea has been that the user was not interested in the details of the calculation process ,but rather by the results !

These can be represented in different ways :tables (figure2),graphs ,graphic display .

The description of figure 2 shows the interest of DR calculation :

The geometry is organized in "lines" , each line is composed of elementary "sections": The lines are here hot leg (BC) , cross over leg (BU) and so on ..the total dose rate is split in participation from the lines (absolute and relative in per cent of total DR) .For each line we can see the relative participation of the most important sections (>0%) and the participation of the main isotopes (here the CO58 et the sum of CO58 and CO60 ("Co")).

With the diversity of the results representations ,one has ready at hand the right indications to propose protection actions such as :partial or total decontamination,suppression of this or that portion of pipe at the beginning of the job rather that at a later date ,additional shielding .

The effect of any of these proposed dispositions can be verified by calculation :this is achieved in the simplest manner ,i.e going back to the geometry input and modifying it consequently .

3-3 validation-qualification

A comparison of measured and calculated DR has been performed by the mean of special surveys, for example at DAMPIERRE 1 and FESSENHEIM 1.It has been shown that a good agreement was obtained .

In both cases , the sources were monitored directly by gamma spectrometry with the EMECC system: a good knowledge of sources is very important to perform a good prediction .

But in addition of gamma spectrometry ,PANTHERE RP allows the use of DR measurements : different hypothesis can be easily tested to simulate the repartition and strength of sources .

IV PERSPECTIVE NEXT FUTURE

PANTHERE RP is a powerful tool that allows to cope with a large span of problems . This software is implemented on the EDF computer network so that the multiple shuffling informations (data base results ..) is not a problem .

We work to create a **PANTHERE RP version V1** for which the specifications are :

- equal or enhance PANTHERE RP V0 capacities ,
- be more user friendly
- available on work stations (and if possible a micro-computer)
- use near worksites .

V OTHERS TOOLS CONNECTED WITH PANTHERE RP

We can distinguish the tools above et below PANTHERE RP .

TOOLS UPSTREAM PANTHERE RP

It are used for the knowledge of sources .

We can cite :

- **FACTOLE** computer code (CEA/SCOS) for the prediction of corrosion products contamination (water and deposit) for the PWR's reactors ,
- **PROFIP** computer code (CEA/SCOS) for the transport of fission products from nuclear fuel ,
- **TRIPOLI** computer code (CEA/SERMA) for the prediction of the transport of gamma or neutrons ,
- **EMECC** (CEA/SCOS) a portable spectrogammameter for the measurements of the volumic or surface contamination for corrosion and fission products : it will be connected with diagnosis softwares for analysis of hot spots or on line survey of fuel cladding .
- **DATA BASE** on the EDF network ,as TIGRE RP from EDF, to manage and analyze the observations on reactors .

TOOLS DOWNSTREAM PANTHERE RP

They are performed to the prediction of individual or collective doses . We can cite the **DOSIANA** code from CEPN/EDF/FRAMATOME , which uses measurements or calculated (with PANTHERE or other code) dose rates .

VI CONCLUSION

PANTHERE RP allows the calculation of the dose rates We hope that it will be used ,in the future, near the worksites of maintenance to be included entirely in the largest process of the prediction of collective doses .

FIGURES

FIGURE 1

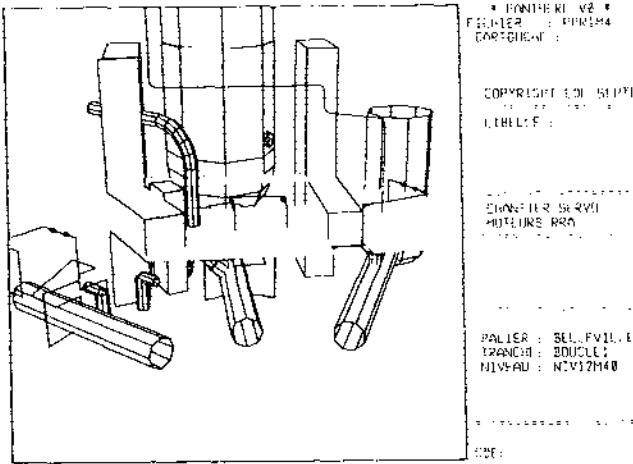

FIGURE 2



DDD AU POINT : 1

TEMPS INITIAL : 0.}

PANTHERE
RP

LIGNE	DDD MREM/H	COSÉ CO	% LIGNE	TRONCONS DONT LA PARTICIPATION AU DDD EST > 20 %
RRA	10.283	16.3/97	11.57	0.21 TR01 0.20 TR03 0.22 TR05 3 SUR 5
BU	2.522	16.6/98	2.84	0.46 TR30 0.20 TR31 0.21 TR 32 3 SUR 5
RIS	6.577	14.1/97	7.40	0.25 TR03 0.21 TR04 2 SUR 6
BC	19.492	5.90/98	21.93	0.94 TR02 1 SUR 2
BF	14.745	14.5/98	16.59	0 SUR 10
BPA	6.382	24.1/97	7.18	0 SUR 13
BPB	12.496	25.4/97	14.06	0 SUR 13
BPC	7.310	21.0/94	8.23	0 SUR 7
SON	5.199	22.2/94	5.85	0.57 TR02 0.22 TR03 2 SUR 4
REN	3.862	20.4/97	4.34	0 SUR 20
TOTAL	88.870			

ON THE SURVEY AND EVALUATION OF RESEARCH SUPPORTED BY THE
SWEDISH RADIATION PROTECTION INSTITUTE

Lars Persson and Leif Moberg

Swedish Radiation Protection Institute
Box 60204, S-10401 Stockholm, Sweden

ABSTRACT

The Swedish Radiation Protection Institute supports research and development (R&D) in the field of radiation protection. A review of the research programme is now being performed. An evaluation of the programme based on this review is then planned to take place. Different methods exist for the evaluation of research and development. The method presently discussed to be used for the evaluation of the Swedish research programme can be described as primarily a judgement of its relevance for the users.

INTRODUCTION

The Swedish Government has supported research and development (R&D) in the field of radiation protection as a part of its atomic research programme since 1945, channelled through the Atomic Research Council. Since July 1st, 1976 the scope of this research has been broadened and the Swedish Radiation Protection Institute (SSI) has become responsible for coordinating the radiation protection research in Sweden. An important objective of the research programme is to produce information that can assist the Institute in making decisions regulating the radiation protection in the country. At the same time support is also given to research of a more fundamental nature. The programme is also complementary and supports the research performed at the Institute. An Advisory Research Board appointed by the Government assists the Institute in establishing the yearly revised research programme and in allocation of grants to the individual research projects.

The research projects are carried out under contracts with SSI. The research is performed mainly at Swedish universities and in disciplines like physics, chemistry, radiophysics, radiobiology and medicine. It is to some extent also performed at different national laboratories and by consultants. Some of the research projects are carried out in cooperation with the equivalent authorities in the other Nordic countries. The international contacts are increasing.

The R&D budget has increased year by year and amounts to 16.6 MSEK (2.7 MUS\$) during the fiscal year 1991/92 of which 9.5 MSEK (1.6 MUS\$) was for radiation protection research connected with nuclear energy and 7.1 MSEK (1.1 MUS\$) was for other research (non-nuclear), including a cooperation with the Radiation Protection Research Programme of the European Communities.

THE RESEARCH AND DEVELOPMENT PROGRAMME

The research programme is divided into two main areas, nuclear energy and other radiation protection research. The first one is divided into projects dealing with radioecology and environmental transfer, radioactive waste and accidents in nuclear power stations. The second main area concerns sources of ionizing radiation in medicine, industry, homes, and research, and sources of non-ionizing radiation.

Nuclear Energy

Radioecology, which is presently the most important research field, involves the behaviour of radionuclides in the biosphere, especially the environmental transfer and bioaccumulation in aquatic and terrestrial ecosystems. The research is based on experimental work in the laboratory and in situ, and on theoretical studies, mainly modelling. A vital question is - how well do the models describe the real world? This has been studied in an international exercise called the Biomovs (BIOSpheric MODEL Validation Study). Phase 2 of Biomovs was initiated in October 1991. As a consequence of the wide spread of radioactive elements in Sweden from the Chernobyl accident a large number of radioecological studies have been performed (ref 1).

In Sweden, as well as internationally, large resources are allocated to research on the management of radioactive waste. Problems of special interest from a radiation protection point of view are questions concerning waste characterization, waste properties and treatment, decontamination, declassification of scrap material, transport, decommissioning and waste storage. Repositories for high level waste and spent nuclear fuel constitute specific problems due to the large time periods involved, which raises questions also of ethical and social nature. Current interests are, for example, understanding various aspects of the decommissioning of commercial nuclear power plants and developing criteria for high level waste repositories.

The research on accidents in nuclear reactors are concentrated on consequence analysis, countermeasures, dose calculations and health effects. There exists a constant development takes place of computer codes and data bases for the evaluation of possible nuclear emergencies.

Non-nuclear research

The research in this field is divided into two main areas: ionizing radiation and non-ionizing radiation.

About 15% of the average dose of ionizing radiation to a person living in Sweden is due to the medical use of radiation, while the radiation from radon and radon daughters in homes contributes 65%.

The present research includes, for example, studies of radiation doses and the quality of diagnostic radiography,

optimisation of the diagnostic procedure, studies of the doses to the patients and cost-benefit analysis, studies of the consequences of new techniques on the radiation protection, studies of optimisation in therapy, a large scale epidemiological study on the lung cancer risk due to radon in houses.

The research on non-ionizing radiation includes mainly studies of radiation in the radiofrequency region and ultraviolet radiation. The research area is relatively new and the possible health effects on living organisms are only partly known.

Besides the research fields which have been briefly described above, research is also performed on risks (analysis, perception, assessment), epidemiology and dosimetry.

A review of the research programme since 1976 is now being performed by one of the authors (L P). All the project reports are looked through and for each project a brief summary is written. The summaries are included in a report to be published in the report series of the Institute.

METHODS FOR EVALUATION OF RESEARCH PROGRAMMES

Scientific evaluation has long been a standard practice. Proposed articles in scientific publications have been reviewed by scientific editors. A so-called peer review has taken place as a normal step before publication. The importance of research for the national productivity and economic growth has led the governments and authorities to implement research programmes and then also to rationalize the spending for research programmes in an optimal way for the country. As a result of this trend towards increased accountability of public spending, evaluation of research programmes has become an issue of importance. It is not only seen as a tool for efficient management of research but also as a help to decision-makers for the future.

There exists several methods today to evaluate research programmes. The following methods have been used for evaluations:

1. Peer reviews,
2. Judgement of the relevance for the users,
3. A cost-benefit analysis,
4. Bibliometric indicators of the scientific value, and
5. Patents as indicators of the utility.

The Commission's of the European Communities evaluation of its Radiation Protection Research Programme may be mentioned (ref 2) as an example of recent work in the field. The impact of the Research Programme on world-wide radiation protection and on human society, as well as the impact on the Commission's own regulatory and economic activities, were also reviewed. The scientific evaluation was carried out by a panel of independent scientists. The efficiency of the management and the socio-economic impact of the programme were evaluated on the basis of

discussions with managers of contracting institutions, with the present and past managers of the programme and the Commission staff. This evaluation was supplemented by the results of a questionnaire sent to all contractors. The method used may be described as a combination of methods one and two.

PREVIOUS EVALUATIONS OF RADIATION PROTECTION RESEARCH PROGRAMMES

The Swedish Natural Science Research Council decided in 1978 to evaluate the fields of radiobiology and radioecology. A peer review was carried out using a mixed Swedish-international scientific panel. Material from the research contract holders was collected and then the members of the evaluation committee performed project site visits. A final meeting was held to discuss all the projects.

The main conclusion by the evaluation panel indicated that some projects might have a considerable importance for applied studies of the environment although the importance for basic research was limited. The development of new technology for survey of environmental hazards should primarily be the responsibility of the authorities, which are concerned with surveillance and monitoring of the environment. The panel proposed negotiations be undertaken to transfer some of the projects to these authorities. The conclusions of the scientific panel have in its main lines been implemented by the Natural Research Council and the Institute.

SURVEY AND EVALUATION OF THE RESEARCH AND DEVELOPMENT PROGRAMME

The decision was recently taken to investigate the possibilities for an evaluation of the Swedish Radiation Protection Institute's radiation protection research and development programme with a judgement of its value primarily for the users. The evaluation procedure planned may, for example, involve the use of the expertise of the decision-makers of the Institute, the users of the R&D inside the Institute, and the Advisory Research Board of the Institute. The credibility of the process will in this way be guaranteed and the utilization of the results and decision-making in the future will benefit from this procedure. The evaluation paper work is carried out by the staff of Research Secretariat of the Institute as a part of its normal duties and it thus also means a building-up of competence in the field. The work to carry through the survey and evaluation of the research programme is still in progress.

REFERENCES

1. Swedish Radiation Protection Institute, 1991, The Chernobyl Fallout in Sweden - Results from a Research Programme on Environmental Radiology, Ed. Moberg, L., Stockholm.
2. Commission of the European Communities, 1989, Evaluation of the Radiation Protection Research Programmes (1980-1984 and 1985-1989), EUR 12145 EN, Office for Official Publications of the European Communities, Luxembourg.

DOSIANA : SOFTWARE PACKAGE FOR OPERATIONAL DOSE MANAGEMENT IN NUCLEAR INSTALLATIONS

LEFAURE C. (*); TARALL G. (**); BREGEON B (***) .

(*) CEPN, BP 48, 92263 Fontenay aux Roses Cedex - France

(**) EDF/DSRE, BP 114, 93203 Saint-Denis Cedex - France

(***) FRAMATOME, BP 3083, 69006 Lyon Cedex 3 - France

DOSIANA has been developed by CEPN for Electricité De France and FRAMATOME, as an ALARA tool, in order to handle operational doses and to integrate radiation protection and management objectives. It allows to calculate potential collective exposure and to assess the impact of various radiation protection actions. DOSIANA is a standardised tool for any nuclear installation or operation. DOSIANA, is nowadays in use at EDF, FRAMATOME and other european nuclear firms. In particular it has been very helpful for the preparation, follow-up and past experience analysis of the steam generator replacement that took place at Dampierre 1 in 1990.

DOSIANA : LOGICIEL POUR LA PREVISION ET L'ANALYSE DE LA DOSIMETRIE OPERATIONNELLE DANS LES INSTALLATIONS NUCLEAIRES

DOSIANA a été développé par le CEPN pour le compte d'EDF et de FRAMATOME, en tant qu'outil d'une politique ALARA, pour mieux maîtriser la dosimétrie opérationnelle. Il permet d'évaluer "a priori" les doses collectives et l'impact de multiples actions de radioprotection. DOSIANA est un outil standard qui peut s'appliquer à n'importe quel type d'installation nucléaire ou de chantier. DOSIANA est actuellement en cours de diffusion à EDF, à FRAMATOME et dans diverses installations nucléaires européennes. Il a, en particulier, servi de support pour la préparation, le suivi et l'analyse de retour d'expérience du chantier de remplacement de générateurs de vapeur de Dampierre 1 en 1990.

INTRODUCTION

L'analyse de l'historique d'opérations de maintenance répétitives sur le parc REP français, a mis en évidence que la dosimétrie des premières opérations aurait pu être réduite significativement si la radioprotection avait joué un rôle plus important dans les différentes phases de ces opérations [1]. Au vu de ces constatations EDF et FRAMATOME ont demandé, en 1987, au Centre d'Etudes sur l'Evaluation de la Protection dans le domaine Nucléaire (CEPN) de développer un logiciel pour assister, dans le domaine de la radioprotection, les responsables d'intervention au niveau de la préparation, et de la réalisation des chantiers en centrales nucléaires.

1 Principes de Base

Le développement de cet outil informatique a été réalisé afin de satisfaire aux objectifs suivants :

- intégrer la radioprotection dans la préparation, le suivi, et l'analyse de retour d'expérience des opérations.
- réaliser une gestion analytique fine de la dosimétrie opérationnelle;
- évaluer les actions de radioprotection au niveau de l'exploitation,

de la maintenance et du démantèlement des installations;
- faciliter la mise en commun des expertises et les interactions entre exploitants, intervenants et .. la radioprotection

De tels objectifs sont cohérents avec l'application du principe ALARA, qui implique une gestion " a priori " de la dosimétrie collective, en complément du contrôle traditionnel " a posteriori " des doses individuelles. Concrètement il s'agissait de combiner ce qu'il est convenu d'appeler " le cycle du contrôle de gestion " avec les phases d'une opération en vue de proposer un outil de dosimétrie analytique.

1.1 Le cycle du contrôle de gestion.

Quel que soit son domaine d'application, un système de contrôle de gestion doit permettre:

- d'établir des objectifs
- de mesurer des performances
- de comparer performances et objectifs
- d'analyser les causes d'écart
- de proposer et de suivre des actions correctrices

Un tel système est récurrent par définition puisque la dernière phase conduit à fixer de nouveaux objectifs pour l'étape (chantier, année...) suivante. Le logiciel DOSIANA n'est autre qu'un outil pour appliquer un tel système au domaine de la radioprotection.

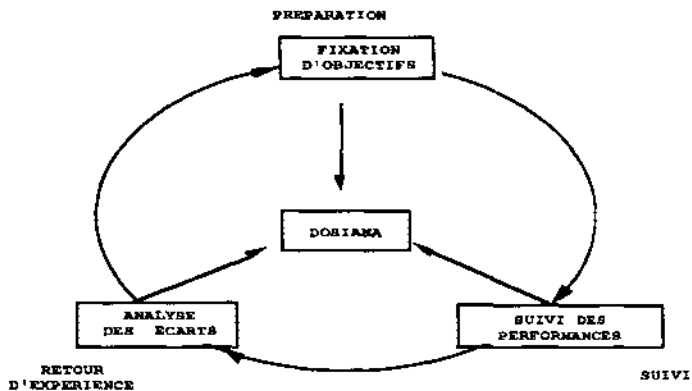

Pendant la phase de **Préparation** (d'un chantier, d'une année...), la quantification prévisionnelle de divers scénarios de réalisation du travail doit aboutir à la fixation d'objectifs dosimétriques. Pendant la phase de **Réalisation**, les performances réelles doivent être systématiquement mesurées et comparées aux prévisions. En cas d'écarts significatifs des actions correctrices peuvent être définies, quantifiées et mise en œuvre. Pendant la Phase de **Retour d'expérience**, l'analyse fine de l'information recueillie permet de proposer des améliorations pour les opérations à venir.

1.2 La Dosimétrie Analytique

Sans une bonne connaissance des débits de dose ambiants, de la durée des tâches, et des conditions de travail, il est très difficile d'interpréter

l'évolution des doses, d'une opération à la suivante ou d'une année sur l'autre; et il est même pratiquement impossible d'identifier les paramètres sur lesquels il est possible d'agir en vue d'améliorer la situation. Dans ces conditions le logiciel DOSIANA a été défini en tenant compte de ces données fondamentales (débits, durées d'exposition...). Pour différencier un tel système de ceux qui se focalisent sur le contrôle des doses individuelles, l'appellation de **DOSImétrie ANALYtique** a été retenue par analogie avec le système de comptabilité où l'on distingue comptabilité générale et comptabilité analytique; la première aboutissant à des bilans et résultats globaux et la seconde permettant d'expliquer la genèse de ces résultats.

2 Le Logiciel DOSIANA

DOSIANA est un logiciel qui fonctionne sur micro ordinateur, éventuellement portable, et utilise un Système de Gestion et d'Analyse de Bases de Données Relationnelles (EXADATA). Il s'agit d'un logiciel interactif et convivial, dont l'utilisation ne requiert pas de connaissances informatiques préalables.

2.1 Structure et Résultats

DOSIANA permet de **créer des bases** de données intégrant tous les paramètres nécessaires à la description et à l'analyse d'une opération du point de vue dosimétrique. Chaque opération y est divisée en phases, sous phases opératoires,..... le niveau le plus fin correspond à des tâches élémentaires dont le découpage apparaît pertinent au regard de l'exposition des opérateurs. Chaque tâche élémentaire est caractérisée par un débit de dose ambiant moyen, et un nombre d'opérateurs. Chaque opérateur participant à une tâche est décrit par l'entreprise à laquelle il appartient, sa spécialité, sa tenue, et son temps d'exposition.

Le logiciel **calcule la dose collective et le volume de travail exposé ainsi que le nombre minimum d'opérateurs satisfaisant les "contraintes" dosimétriques retenues pour l'opération**. Ces résultats sont disponibles pour le chantier dans son ensemble ou éclatés en fonction de critères divers tels que les phases opératoires, les spécialités des opérateurs, les entreprises intervenantes.....

Les fonctionnalités du Système de Gestion et d'Analyse de Bases de Données permettent de générer des scénarios différents de la référence initiale. L'utilisateur de DOSIANA peut alors aisément **évaluer l'impact de multiples actions de radioprotection sur les doses et les temps d'exposition**. Les résultats issus de DOSIANA, en termes d'efficacité des actions envisagées pour réduire l'exposition, sont directement utilisables pour les études ALARA.

2.2 Fonctionnalités

Le logiciel est conçu pour permettre :

- à **plusieurs équipes** de fusionner leur travail dans une base commune;
- de communiquer l'intégralité d'une base à un autre utilisateur, qui peut ensuite l'adapter à l'environnement propre à son installation; ce qui est particulièrement intéressant pour les exploitants disposant de plusieurs installations similaires ;

- de traiter les données et les résultats avec d'autres traitements de texte, tableurs ou logiciels graphiques.

L'utilisateur peut choisir et créer sa propre structure d'édition de données et de résultats:

- tableaux croisés (ex: dose collective pour une opération par phase et spécialité d'opérateurs)
- tableaux d'écart (ex: gains en volume de travail exposé par spécialité et condition de travail après mise en œuvre d'une option de radioprotection)
- tableaux intégrant données, résultats, et opérations algébriques sur ces données et résultats (ex: calcul des débits moyens par phase, ou des doses individuelles moyennes par tâche élémentaire.....)

DOSIANA permet d'effectuer des sorties graphiques, des analyses statistiques simples sur données ou résultats (moyennes, écarts types, régressions simples), de sélectionner tout ou partie d'une base de données et de fusionner plusieurs modalités d'une variable lors d'une édition.

2.3 Applications

DOSIANA est tout à fait adapté à la gestion de bases de données importantes correspondant à des opérations majeures ; le logiciel a été utilisé pour :

- la préparation, le suivi et l'analyse du retour d'expérience du remplacement de générateurs de vapeur de Dampierre 1 (France) en 1990 par EDF et FRAMATOME ; DOSIANA a été particulièrement utile pour éclairer les décisions en matière de décontamination, mouvements d'eau dans les circuits...; pour mettre en place des entraînements spécifiques et ajuster le nombre d'opérateurs aux doses collectives prévues [2].
- la préparation, le suivi et l'analyse du retour d'expérience du démantèlement du réacteur BR3 à MOL en Belgique ; 1990/1991.

DOSIANA est tout aussi utile pour la préparation d'opération spécifiques de moindre importance: - comparaison de différents procédés de soudures des tuyauteries primaires; 1990 (FRAMATOME); - travaux sur l'échangeur-régénérateur du contrôle chimique et volumétrique ; 1991 (FRAMATOME)

DOSIANA commence aussi à être utilisé par EDF pour évaluer l'impact de la robotisation de diverses opérations de maintenance.

Ces premières applications ont démontré que DOSIANA pouvait être utilisé après une formation très courte et qu'il est suffisamment flexible pour être appliqué à des opérations de taille et de complexité très différentes.

DOSIANA sera prochainement doté d'un module spécifique de suivi des opérations et complété par un module d'analyse économique.

Bibliographie:

[1] Lochard J. & al. "Analyse de la radioprotection des premières opérations de microbillage des tubes de générateur des tranches 900 MWe" Radioprotection, Vol 22, N°4, 1987

[2] Jurion O. & al. "La radioprotection du remplacement des générateurs de vapeur à Dampierre, 1 R.G.N., N°5, 1990

COMPORTEMENT DU RADIOCESIUM EN ECOSYSTEME FORESTIER CONTAMINE LORS D'UN ACCIDENT NUCLEAIRE.

Y. THIRY*, C. RONNEAU** ET C. MYTTENAERE*.

* LAB. DE PHYSIOLOGIE VEGETALE, UNIVERSITE CATHOLIQUE DE LOUVAIN,
LOUVAIN-LA-NEUVE, BELGIQUE.

** LAB. DE CHIMIE INORGANIQUE, ANALYTIQUE ET NUCLEAIRE
UNIVERSITE CATHOLIQUE DE LOUVAIN, LOUVAIN-LA-NEUVE, BELGIQUE.

BEHAVIOUR OF RADIOCESIUM IN FOREST ECOSYSTEM CONTAMINATED DURING A NUCLEAR ACCIDENT.

Vegetation and soils sampling were realized in 2 forest zones near the accidented power plant of Chernobyl. The ^{137}Cs distribution in a red pine stand is established; many specific measures of wood complete the study. Results discussion point out the difficulties to manage the contaminated forest area without a good knowledge of the radioelement biochemical cycle.

INTRODUCTION

En Europe de l'ouest, comme en URSS, l'efficacité du couvert forestier à piéger la radioactivité a mis en évidence le rôle important et complexe que peuvent jouer les forêts en cas de retombées radioactives. Dès après l'accident de Tchernobyl, les arbres (détruits par irradiations directe et indirecte) de la forêt rouge ont été enterrés sans tenir compte de l'avis des radioécologistes soviétiques. Les effets négatifs qui sont actuellement observés illustrent le manque de concertation entre responsables des contre-mesures (Tikhomirov et al., 1991(1)). Particulièrement en zones naturelles, les décisions prises par les agents de la radioprotection responsables des opérations d'assainissement dans les régions contaminées, doivent se baser sur l'étude radioécologique (multidisciplinaire) du comportement de la radioactivité interceptée. L'aménagement de surfaces forestières contaminées requiert donc une très bonne compréhension du cycle des radioéléments entre les divers compartiments qui constituent l'écosystème "forêt".

L'objectif de cet exposé est de présenter la distribution du radiocésium entre les compartiments primordiaux d'un peuplement de pin sylvestre près de Tchernobyl, celle-ci résultant de l'évolution du cycle du radiocésium depuis l'accident (4 ans). Différents enseignements peuvent être tirés du point de vue de la restauration sanitaire des sites forestiers.

RESULTATS ET DISCUSSION

Après interception par la canopée (80-90 % du dépôt), certains radioéléments dont le radiocésium sont susceptibles d'être incorporés rapidement au cycle biologique naturel suite à son absorption au niveau du feuillage. En même temps, le ruissellement des précipitations sur le houppier contribue à l'accumulation d'une grande partie de l'activité à la surface du sol. Tikhomirov et al. (1991)(1) ont évalué respectivement à 1 et 6-8 mois les demi-vies du phénomène de lessivage de la radioactivité interceptée par les arbres dans les zones contaminées de Tchernobyl et de Kyshtym. L'"autoépuration" naturelle du couvert forestier est maintenant achevée dans le cadre de la contamination accidentelle de Tchernobyl. La figure 1 présente l'état de contamination actuelle d'un peuplement de pin sylvestre (30 ans) à Bourakovka (zone forestière à 15 km à l'ouest de Tchernobyl). Si on fait abstraction du poste "écorce" sur laquelle les dépôts radioactifs résiduels peuvent expliquer la contamination élevée, il apparaît que les organes pérennes: branches et bois du tronc, peuvent stocker à court terme une part non négligeable du radiocésium incorporé dans la phytocénose (Thiry et al., 1996).

Figure 1

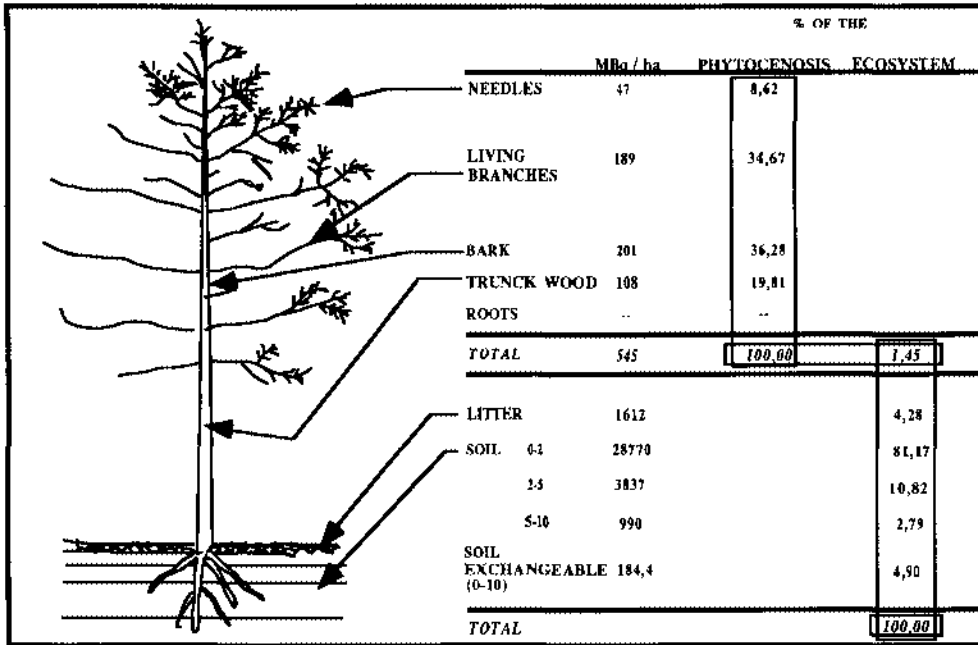

Le sol contient de loin la majorité du radiocésium déposé; la migration est peu efficace puisque plus de 80% de l'activité est toujours localisée dans les couches organiques de surface (0-2 cm). En plus d'un blocage physique de la migration des particules radioactives, des processus physico-chimiques de fixation interagissent à ce niveau. En effet, des phénomènes spéciaux de rétention du Cs ont été mis en évidence spécialement dans les couches du sol où matières organiques et minérales sont intimement confondues. L'affinité pour le Cs des complexes argilo-humiques semble plus élevée que celle déjà connue des particules minérales du sol (Thiry et al., 1991).

Fig.2: Distribution des teneurs en ^{137}Cs dans les organes de pin sylvestre.

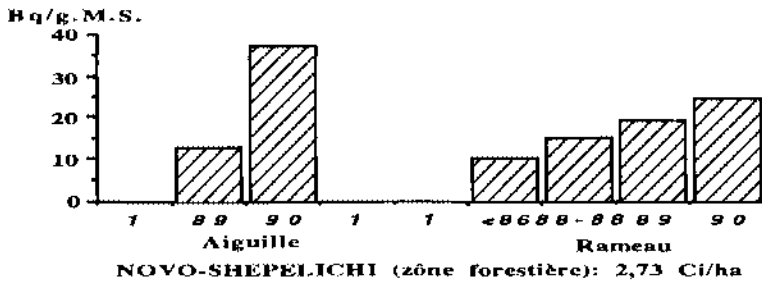

Malgré l'efficacité de la rétention du Cs, 5% ($1844 \cdot 10^6$ Bq/ha) du Cs contenu dans l'écosystème sont échangeables dans le substrat. Cette observation montre qu'il persiste un risque de contamination croissante de

la végétation. La Fig. 2 met en évidence l'augmentation des teneurs en ^{137}Cs dans les aiguilles et rameaux (pin sylvestre) formés après 1986 (prélèvements effectués à Novo-Shepolichi, zone forestière à 5 km de la centrale accidentée). De simples mécanismes de retranslocation acropétale n'expliquent pas à eux seuls la contamination croissante. En effet, à la fig. 3 sont présentées les teneurs en ^{137}Cs dans les rameaux d'un jeune plant de pin sylvestre (prélevé à Bourakovka) qui s'est développé après l'accident. La stabilité, voire l'augmentation du niveau des concentrations en Cs montre qu'il existe un phénomène efficient d'absorption racinaire (micorhizes?). Celui-ci correspond à un facteur de transfert maximum vers les rameaux de $8 \cdot 10^{-3}$ (Bq/g.M.S./ Bq/g.sol sec) à partir du substrat 0 (0-2cm). En outre, l'écorce semble concentrer le Cs; malgré sa faible biomasse, plus de 50% de l'activité des rameaux y est localisée.

Fig.3: Teneurs en ^{137}Cs dans les rameaux de pin sylvestre.

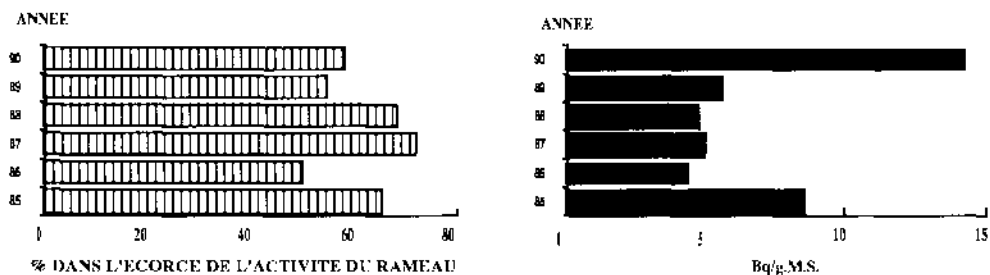

En ce qui concerne la distribution du radiocésium dans les cernes annuels du tronc (pin sylvestre(35 ans) échantillonné à Bourakovka), la Fig. 4 montre que le bois est contaminé globalement de façon homogène, l'aubier étant légèrement plus contaminé que le duramen (2 fois plus). Les cernes formés après 1986 présentent cependant des teneurs supérieures en ^{137}Cs . La teneur élevée du cerne à peine élaboré de printemps 90 témoigne de l'intensité des mouvements du radiocésium au niveau des tissus jeunes (cambium). Si l'activité du bois formé se maintient à un niveau moyen de $8,98 \text{ Bq/cm}^3$, on peut raisonnablement évaluer que dans les conditions étudiées ($0,39 \text{ Ci/ha}$), la contamination de ce type de peuplement augmentera au minimum de $45 \cdot 10^6 \text{ Bq/ha.an}$ de Cs incorporé dans la masse nouvellement formée du tronc (production de $5 \text{ m}^3/\text{ha.an}$). Si on se réfère aux niveaux permis en ^{137}Cs estimés par Thikomirov et al. (1991(2)) pour l'utilisation de bois contaminé, le bois qui serait produit par ce peuplement ne pourrait même pas être utilisé à des fins industrielles (même décortiqué), ni servir à la construction et encore moins comme source de combustible (respectivement 1.1, 1.1 et 5.5 fois trop contaminé).

Fig.4: Evolution de l'activité en ^{137}Cs dans le tronc de pin sylvestre.

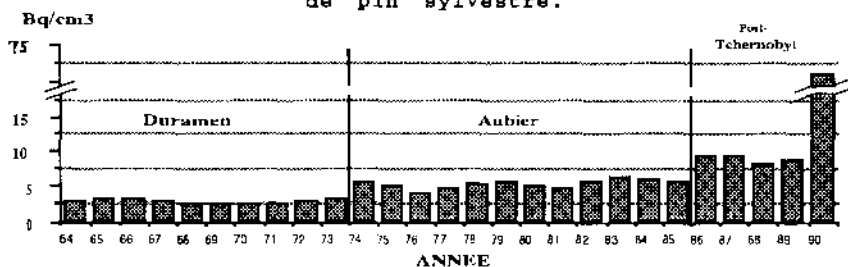

CONCLUSIONS

Le comportement du radicésium en forêt est complexe. La mobilité qui caractérise la redistribution du Cs au niveau de la végétation contraste avec les mécanismes de rétention qui agissent à la surface du sol. Le substrat représente indubitablement le pool primordial de Cs dans l'écosystème forestier. L'incidence d'une modification de la stabilité physico-chimique des couches organiques (par coupe à blanc, éclaircie, enlèvement de litière..) est prioritaire dans l'étude du risque à long terme d'une contamination des compartiments annexes (végétation, nappe phréatique,...).

La variabilité des facteurs écologiques (type de sol, d'humus, d'essence) et économiques (forêt de production, de protection, de récréation,...) conditionne le choix des contre-mesures à adopter.

Dans ce contexte, les opérations d'assainissement nécessitent pour chaque site la connaissance de la distribution des radionucléides et des mécanismes qui influencent leurs mouvements. A ce propos, des opérations d'abattage massif ou de travail de sol doivent être envisagées avec prudence. De plus, ce type d'opération est justifiée dans certaines conditions écologiques très locales mais est économiquement peu applicable sur de grandes surfaces (Mishenkov et al., 1991). L'exploitation du bois en territoire contaminé doit également tenir compte des possibilités d'accumulation de la radioactivité avec le temps et du rôle que joue l'écorce dans ce phénomène.

REFERENCES:

- MISHENKOV, N.N., FEDETOV, I.S., MESHALKIN, B.S. and ARKHIPOV, N.P.
Improvement of ecological and hygienic conditions in contaminated forest stands by ground-litter disposal. Seminar on "Radicecology and countermeasures". Soviet General Assembly, Kiev, April 27-May 4, 1991.
- THIRY, Y., SOMBRE, L., MYTTENAERE, C., RONNEAU, C., KUTLAHMEDOV, Y.A. and DAVIDCHOCK, V.S.
Behaviour of ^{137}Cs in forested polygons of the Chernobyl contaminated zones.
All-Union Conference "Geochemical Pathways of Artificial Radionuclides in Biosphere" October 15-19, 1990, Gomel, USSR (1990).
- THIRY, Y. and MYTTENAERE, C.
Behaviour of radiocesium in forest multilayered soils.
J. Env. Radioact. (in press).
- TIKHOMIROV, F.A., SHEGLOV, A.I. and SIDOROV, V.P. (1)
Radiation protection measures for the forests of Chernobyl accident zone and estimation of its effect. Workshop on "The Relative Effectiveness of Agricultural Countermeasures Techniques (REACT)". CEC Meeting (DG XII-D-3; DG XI-A-1), Brussels, October 1-4, 1991.
- TIKHOMIROV, F.A., SIDOROV, V.P. and SHEGLOV, A.I. (2)
Forest and forestry under conditions of radioactive contamination. Workshop on "The relative Effectiveness of Agricultural Countermeasures Techniques (REACT)". CEC Meeting (DG XII-D-3; DG XI-A-1), Brussels, October 1-4, 1991.

TRANSPORT OF CHERNOBYL RADIONUCLIDES IN FRESHWATER LAKES

G. Lindner¹, I. Greiner¹, R. Grom¹, S. Kaminski¹, J. Kleiner⁴, A. Kulikov⁵, W. Pfeiffer³, J. A. Robbins², O. Seewald¹, O. Smirnova⁵ and Ch. Wilhelm¹

¹Institut für Innovation und Transfer, Fachhochschule Ravensburg-Weingarten, D-7987 Weingarten, F.R.G., ²Great Lakes Environmental Research Laboratory, Ann Arbor, Michigan 48105, USA; ³Universität Konstanz, Fakultät für Physik, D-7750 Konstanz, F.R.G., ⁴Zweckverband Bodensee-Wasserversorgung, Betriebs- und Forschungslabor, D-7770 Überlingen, F.R.G., ⁵Institute of Evolutionary Morphology and Ecology of Animals, USSR Academy of Sciences, Moscow, USSR.

ABSTRACT

The importance of the limnological character of lakes on the transport processes of longlived radionuclides from the Chernobyl fallout (Cs-134, Cs-137, Ru-106, Sb-125) is exemplified at Lake Constance, a large hardwater lake, and Schreckensee and Vorsee from the same prealpine region, which are small lakes with high organic loads. For Cs radionuclides in Lake Constance adsorption at clay particles is the dominating process, whereas in the other lakes the interaction with organic substances plays an important role with respect to their ecological behaviour.

INTRODUCTION

As a consequence of the Chernobyl accident radionuclides become introduced into freshwater lakes in Europe at a well-defined date, which then participated in the ecological transport processes according to their respective speciation /1/. Of particular interest are long-lived radionuclides like Cs-137 or Sr-90, which are speciated in cationic form, and Ru-106 and Sb-125, which are anionically speciated in freshwater /2/, since they participate in seasonal cycles in lakes. This contribution is mainly focussed on Cs radionuclides and emphasizes the importance of the ecological structure of lakes for self-cleaning processes in the waterbody and the transfer into aquatic food chains. Examples are presented for different types of lakes represented by Lake Constance (Bodensee) as a deep hardwater lake, which is an important drinking water reservoir, and Schreckensee and Vorsee from the same prealpine region as small lakes with high organic load. Implications with respect to Kiev reservoir are discussed.

RESULTS AND DISCUSSION

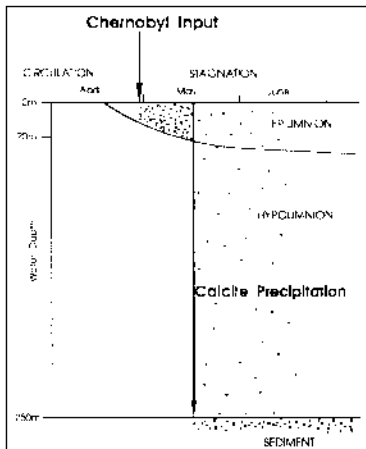

In Lake Constance radionuclides from the Chernobyl fallout were introduced in the time interval between the establishment of summer stratification (mid-April) and the calcite precipitation event induced by the spring algae bloom (mid-May, see fig. 1). The input occurred mainly across the water surface during rainfalls and the contribution from tributaries was only minor /3/. Therefore the dissolved radionuclides were initially restricted to the epilimnion. There Cs radionuclides became adsorbed at suspended clay mineral particles, which subsequently, during the calcite precipitation event, acted as nucleation sites for the growth of calcite crystals resulting in a considerable increase in their sinking velocity /4/. This caused an effective cleaning of the epilimnion and a rapid

Fig. 1: Transport processes of dissolved radionuclides from the Chernobyl fallout in Lake Constance.

transport to the sediment and explains (i) the peak in the vertical radiocesium flux in settling particles during calcite precipitation /5/, (ii) the minimum of dissolved radionuclides in the epilimnion observed at the end of the stratification periods in 1986 and 1987 /1,6/ and (iii) the formation of a sharp horizon of Cs radionuclides from the Chernobyl fallout in the bottom sediment, which is well separated from the Cs-137 input originating from the nuclear weapons testing fallout (fig. 2). This removal process could be reconstructed quantitatively within an epilimnetic scavenging model /4/. Since Cs radionuclides became incorporated into clay mineral particles at internal binding sites, their resolvability from sediment is very small: Not more than 10% of the Chernobyl-related Cs-137 inventory of a representative sediment sample could be brought back into solution in a five-step selective extraction procedure leaving only clay, quartz and feldspars as solid residues (fig. 3).

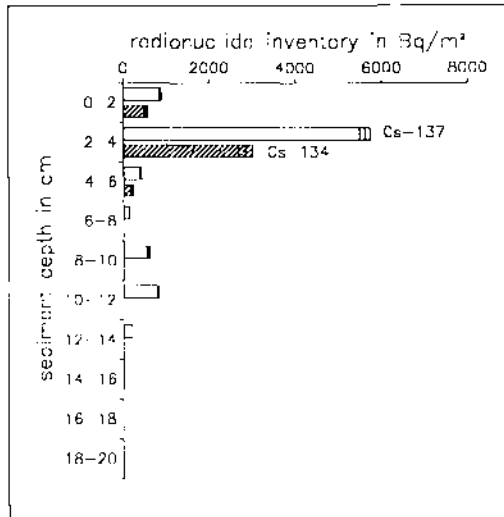

Fig. 2: Depth distribution of Cs-134 and Cs-137 in bottom sediments from Lake Constance sampled in 1991.

Ru-106 and Sb-125 were also transported to the sediment mainly during calcite precipitation in May 1986 and the removal efficiency for these radionuclides was even higher than for Cs /5/. From model calculations, however, particulate organic matter turned out to be the reactive phase in the adsorption process prior to precipitation /4/, which corresponds to the anionic speciation of these radionuclides. Accordingly, by treating sediment samples with respect to the extraction of organically bound anions, about 30% of these radionuclides could be brought back into solution.

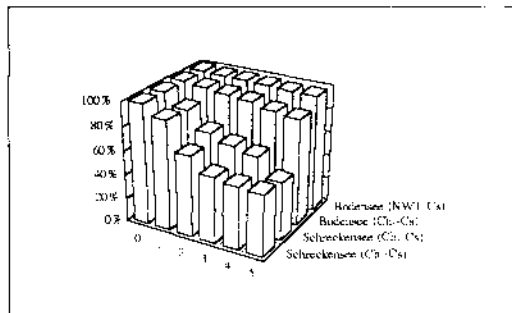

Fig. 3: Residual fractions of Cs-137 radionuclides in sediments from Lake Constance (Bodensee) and Schreckensee after Cs ion exchange (1), dissolution of carbonates (2), organic matter (3), Fe- and Mn-hydroxides (4) and amorphous silicates (5).

These processes have important implications with respect to food chain transfer of Cs radionuclides from the Chernobyl fallout: (i)

The rapid and efficient removal of dissolved Cs radionuclides restricted drinking water contaminations to very low levels (below 1 Bq/m³ Cs-137 in 1991 /7/); (ii) the danger of redissolution of Cs radionuclides from sediments is very low; (iii) the initial accumulation of dissolved Cs radionuclides in the euphotic zone and their early removal explains the time dependence of the observed specific Cs-137 activity of planctivorous fish (whitefish). A rather steep increase in spring 1986 was followed by a rapid and continuous decrease with an effective half-time of about 4 months (fig. 5). As a consequence the transfer of Cs-137 radionuclides in the trophic chain remained limited and the contamination of carnivore fish (pike and eel) never exceeded the initial contamination of planctivorous fish.

Schreckensee and Vorsee, whose watershed includes swampy regions, suffered the same input event at the same time. In Vorsee, the specific activity of dissolved Cs-137 in the water even in 1991 persisted at a level of about 200 Bq/m³ (as measured after precipitation of dissolved Cs ions with ammoniummolybdenumphosphate ion exchanger at pH = 4) and exhibited a significant maximum in winter 1990/91 (fig. 4). This was attributed to the redissolution from sediments due to a decomposition of organic substances, to which organically speciated Cs radionuclides were bound. Correspondingly, in deeper Schreckensee a considerable increase of specific Cs-137 activity towards the sediment was observed during the stratification period (7). The binding strength of Cs radionuclides to sediments in this lake is much weaker than in Lake Constance; about 50% of the Cs inventory could be brought back into solution applying the same extraction procedure (fig. 3). This is attributed to a predominantly organic binding of Cs radionuclides in these sediments. The implications on fish contaminations became evident from fig. 5:

The general contamination levels of fish are higher than in Lake Constance and the specific Cs-137 activity of carnivorous fish is higher than that of herbivorous fish due to food chain accumulation. Additionally, the decrease of contamination is much slower than in Lake Constance. The importance of organic processes in these lakes is emphasized by a considerable increase of the Ru 106 and Sb-125 to Cs-137 isotopic ratio in sediments from these lakes.

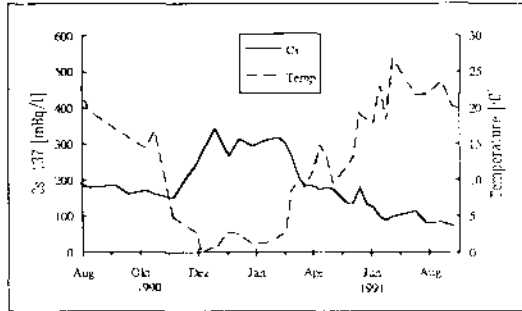

Fig. 4: Concentration of dissolved Cs-137 and water temperature in Vorsee 1990/91.

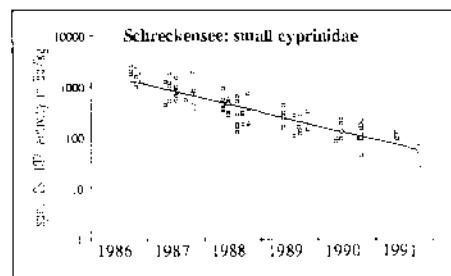
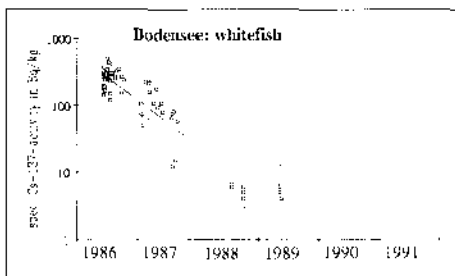
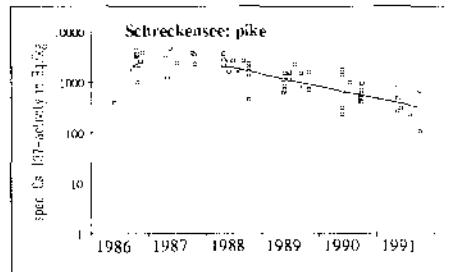
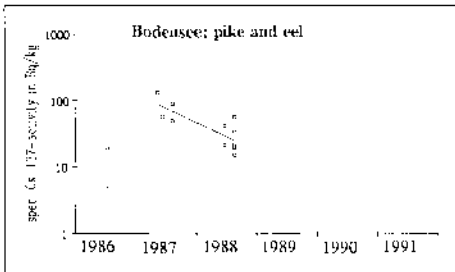

Fig. 5: Specific Cs-137 activity in carnivorous (top) and herbivorous (bottom) fish species from Lake Constance (Bodensee) and Schreckensee.

Results of the radiocesium contamination of fish from Kiev reservoir suggests a closer similarity to the second type of lakes: Both the contamination distribution among different fish species as well as the time constants of the decrease of contamination of fish from the central part of Kiev reservoir are similar to findings from Vorsea (fig. 6). This may be considered as an indication for continuous input of Cs radionuclides or due to redissolution from sediments as well as for the absence of effective self-cleaning processes in this reservoir. It is emphasized, however, that Sr-90 radionuclides in this aquatic ecosystem are of much higher importance than in any other European lake outside Sowjetunion, mainly due to the release of this radionuclide from nuclear fuel particles /8/.

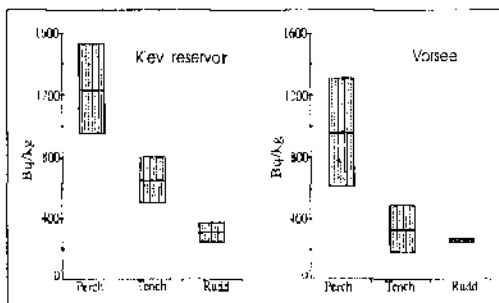

Fig. 6: Specific activity of Cs-137 in perch, tench and rudd from Kiev reservoir (left) and Vorsea (right) in 1990.

Support from German Research Foundation (SFB248 "Cycling of Matter in Lake Constance") and the Ministries of Science and of Environment of the State Baden-Württemberg are gratefully acknowledged.

REFERENCES:

- /1/ P.H. Santschi, S. Bollhalder, K. Farrenkothen, A. Lueck, S. Zingg and M. Sturm: "Chernobyl Radionuclides in the Environment: Tracers for the Tight Coupling of Atmospheric, Terrestrial and Aquatic Geochemical Processes", *Environ. Sci. Technol.* 22 (1988) p. 510-516.
- /2/ P.H. Santschi, S. Bollhalder, S. Zingg, A. Lueck and K. Farrenkothen: "The Self-cleaning Capacity of Surface Waters after Radioactive Fallout. Evidence from European Waters after Chernobyl, 1986-1988", *Environ. Sci. Technol.* 24 (1990) p. 519-527.
- /3/ G. Lindner, M. Becker, R. Eckmann, P. Frenzel, J. Kleiner, D. Petermann-Seyboldt, W. Pfeiffer, U. Wahl and E. Recknagel: "Biological Transfer and Sedimentation of Chernobyl Radionuclides in Lake Constance", in Titzler, M.M. and Serruya, C. (eds.): "Large Lakes, Ecological Structure and Function", Springer, Berlin (1990), p. 265-287.
- /4/ J.A. Robbins, G. Lindner, W. Pfeiffer, J. Kleiner, H.H. Stabel and P. Frenzel: "Epilimnetic Scavenging and Fate of Chernobyl Radionuclides in Lake Constance", *Geochimica Cosmochimica Acta*, submitted.
- /5/ G. Lindner, W. Pfeiffer, U. Wahl, J. Kleiner, H.H. Stabel, P. Frenzel, J.A. Robbins, F. Giovanoli, A. Lenhard and E. Recknagel: "Sedimentation of Longlived Radionuclides in Lake Constance", *Proc. Int. Conf. Heavy Metals in the Environment* (J-P. Vernet, ed.), CEP Consultants Ltd, Edinburgh, 1989, p. 449-452.
- /6/ A. Mangini, U. Christian, M. Barth, W. Schmitz and H.H. Stabel: "Pathways and Residence Times of Radiotracers in Lake Constance", in Titzler, M.M. and Serruya, C. (eds.): "Large Lakes, Ecological Structure and Function", Springer, Berlin (1990) p. 245-264.
- /7/ G. Lindner, I. Greiner, R. Grom, K. Hain, M. Ibler, S. Kaminski, J. Kleiner, W. Pfeiffer, J. Robbins, O. Seewald, Ch. Wilhelm and M. Wunderer: "Entfernungs- und Akkumulationsprozesse von Cäsium-Radionukliden in Seen des Voralpengebietes", in H. Jakobs and H. Bonka (Hrsg.): "Strahlenschutz für Mensch und Umwelt", Verlag TÜV Rheinland, Köln, 1991) p. 247-252.
- /8/ G.V. Voytsekhovich, V.A. Borzilov, V.A. Konoplev: "Hydrological Aspects of Radionuclide Migration in Water Bodies Following the Chernobyl Accident", in *Proc. Sem. Comparative Assessment of the Environmental Impact of Radionuclides Released during Three Major Nuclear Accidents: Kyshtym, Windscale, Chernobyl*, Commission of the European Communities, 1991, p. 527-548.

RADIOCESIUM BODY BURDENS IN NORTHERN CANADIANS

B. L. Tracy and G. H. Kramer

Bureau of Radiation and Medical Devices
Department of National Health and Welfare
Ottawa, Canada

ABSTRACT

Whole body measurements were carried out on 1117 Canadians living in five Arctic communities during 1989 and 1990 in order to assess the uptake of radiocesium from the lichen-caribou-human food chain. The Cs-137 body burdens increased with age, and were twice as high for men as for women. There was a discrepancy between the reported meat consumption and the measured body burdens. Average radiation doses from ingested radiocesium varied from 0.01 to 0.10 mSv/a.

INTRODUCTION

It has been known since the early 1960's, when intensive testing of nuclear weapons was carried out in the atmosphere, that the lichen-caribou-human food chain is an important pathway for the uptake of radiocesium. This is particularly true in far northern regions where fallout radionuclides accumulate on slowly growing lichens. These in turn serve as the major food source of reindeer and caribou during the long winter months. Many northern Canadians depend on caribou hunting for their main supply of meat.

After the Chernobyl accident in 1986, renewed concern was raised about possible contamination of Canadian caribou herds by fallout radiocesium. Measurements carried out on caribou meat by this laboratory between 1986 and 1988 showed that only about 25% of the radiocesium in Canada resulted from the Chernobyl accident; the remainder was residual fallout from early weapons testing. However, exposure to radiocesium depends on the diet and lifestyle of the people, as well as on the levels in caribou meat. The only way to obtain a direct measure of exposure to humans is to carry out whole-body monitoring. This paper describes such a set of measurements.

EXPERIMENTAL MEASUREMENTS

Measurements were carried out in the following communities:

Baker Lake, NWT	Feb., 1989	416 subjects
Rae-Edzo, NWT	March, 1989	378 subjects
Old Crow, Yukon	March, 1990	92 subjects
Aklavik, NWT	March, 1990	115 subjects
Ft. McPherson, NWT	April, 1990	116 subjects

Efforts were made to obtain a good representation from both sexes and all age groups.

The counting equipment was usually set up at the nursing station in each community. The subject was seated comfortably in a chair. A 5" x 4" Harshaw NaI(Tl) scintillation detector was placed close to the abdomen and thighs and a 3" x 3" detector was placed close to the chest. In the case of a small child the chest detector was omitted. Each measurement required only 5 minutes. The signals were processed by a Canberra S100 data acquisition system and the resulting gamma ray spectrum was displayed on a video screen which was visible to the subject. Cesium-137 was identified by its photopeak at 661.6 keV. At the end of the measurement the subject was given a printout of the result and an explanation of its significance. The counting system had been previously calibrated at the laboratory by using phantoms resembling an adult male, a 10-year old, and a 4-year old and filled with water containing a solution of Cs-137. The detection limit varied between 0.1 and 0.3 kBq of Cs-137, depending on the background at the nursing station. Each subject was asked to complete a dietary survey, with the assistance of a native interpreter. The subject estimated the amount of caribou eaten at each meal by pointing to models of various sized pieces of meat. Radiocesium analyses were carried out on samples of caribou meat obtained from recent kills in each community.

RESULTS AND DISCUSSION

Figure 1 shows how the radiocesium body burdens varied with age group and sex in one particular community -- Baker Lake. Results for the other communities were similar. Note that the levels were very low in children, then rose during the adolescent and early adult years to reach a peak in middle age (50 - 60). After age 60 the levels declined. Results for males were consistently about a factor of two higher than those for females.

Table 1 summarizes the results for the five communities for all adults (age >20). The predicted body burdens were calculated as follows:

$$BB(kBq) = \text{Conc. in meat}(kBq/kg) \times \text{consumption}(kg/wk) / 7 \times \text{GI uptake} \\ \times \text{biological half-time}(days) / \ln(2)$$

The average weekly consumptions of caribou meat were based on results provided in the dietary survey. GI uptake was assumed to be 100 % (1). The biological half-times for radiocesium in the body were taken to be 96 days for men and 65 days for women (2). In all cases, the observed body burdens in men were about twice as high as those in women. This is only partially explained by the differences in reported consumption. The remainder of the factor of two can be explained by the shorter biological half time for radiocesium in women (65 as opposed to 96 days). The observed body burdens are well correlated with the measured concentrations in

meat for each community ($r = 0.973$ for men and 0.985 for women).

The most notable feature of Table 1 is that the predicted body burdens are consistently 2 to 4 times as high as the measured values. Aklavik would appear to be an exception, but the measured values for this community are too close to the detection limit (0.2 kBq) to draw any conclusions. The discrepancy between predicted and observed values is difficult to explain. One possibility is that the GI uptake factor is considerably less than 100% for radiocesium in meat. To test this possibility, several volunteers from this laboratory consumed known amounts of caribou meat containing Cs-137(3). Whole body, urine and fecal measurements were all consistent with a GI uptake factor $>98\%$. The experiment also showed that the biological half times assumed here are quite reasonable. The only remaining possibility is that the people were consistently overestimating their consumption of caribou meat. It is curious that the degree of overestimation should be consistent between sexes and from one community to another. Furthermore, the degree of overestimation was found to be consistent even between different age groups in the same community. If people were, in fact, overestimating their meat consumption, then the radiocesium body burden measurements provide an independent means of estimating consumption. This could be useful for an accurate assessment of the intake of other toxic substances. The annual dose to each sex group in each community from the observed Cs-137 body burden has been calculated from:

$$\text{Dose (mSv/a)} = 0.043 \times \text{body burden (kBq)}$$

This assumes a) body burden is maintained for one year
b) energy deposited per disintegration is 0.59 MeV
c) an adult weighs 70 kg.

The values are given at the bottom of table 1. These values represent an insignificant increase over natural background exposure of 2 to 3 mSv/a. The highest body burden observed for any individual was 9.5 kBq, which gave a dose of 0.41 mSv/a.

REFERENCES

1. International Commission on Radiological Protection, Limits of Intakes of Radionuclides by Workers, ICRP Publication 30, Part I, Pergamon, Oxford, 1979.
2. G. Schwartz and D.E. Dunning, Imprecision in estimates of dose from ingested Cs-137 due to variability in human biological characteristics, Health Phys. 43, 631-645, 1982.
3. B.L. Tracy and G.H. Kramer, Verification of the ICRP retention model for the human uptake of Cs-137 from caribou meat, 37th Annual Conference on Bioassay, Analytical and Environmental Radiochemistry, Ottawa, Canada, October 7-11, 1991.

Table 1. Consumptions of caribou meat and Cs-137 body burdens

	Rae-Edzo	Baker Lake	Old Crow	Fort McPherson	Klaviik
No. of adults					
men	128	122	30	38	34
women	109	144	20	60	49
Consumption					
men (kg/wk)	1.38	2.26	1.18	0.81	0.53
women (kg/wk)	0.95	1.54	0.90	0.64	0.52
Conc. in meat (Bq/kg)	0.294	0.207	0.092	0.092	0.019
Predicted Cs burden					
men (kBq)	8.03	9.26	2.15	1.47	0.20
women (kBq)	3.74	2.33	1.11	0.79	0.13
Observed Cs burden					
men (kBq)	2.22	1.97	0.63	0.57	0.27
women (kBq)	1.24	0.84	0.24	0.30	0.14
Observed/predicted					
men	3.62	4.70	3.41	2.58	0.74
women	3.02	2.77	4.62	2.63	0.93
Annual dose					
men (mSv/a)	0.10	0.08	0.03	0.02	0.01
women (mSv/a)	0.05	0.04	0.01	0.01	0.01

Figure 1. Radiocesium body burdens for each age and sex group in Baker Lake.

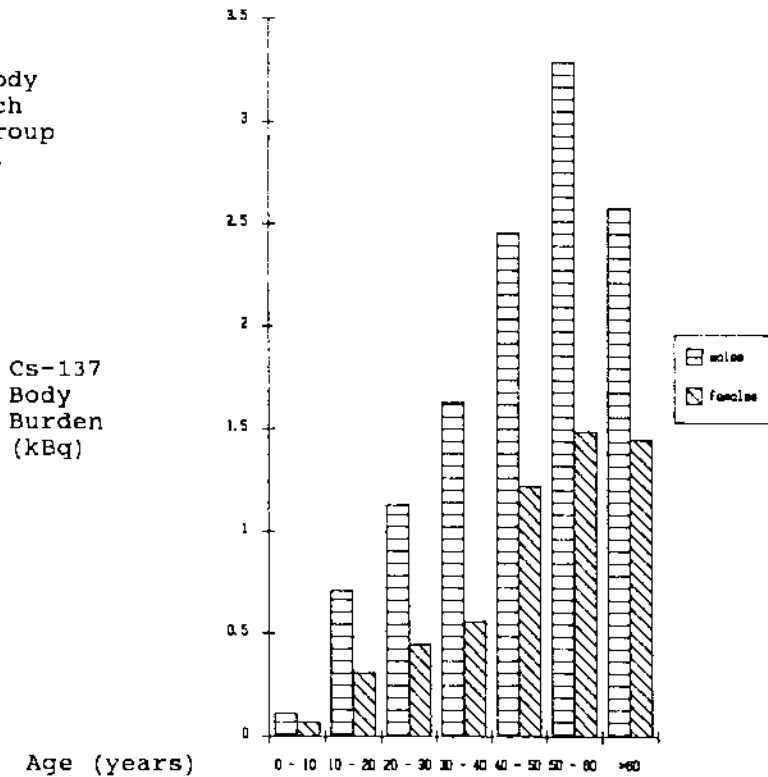

STUDIES ON IN-SITU MEASUREMENT OF FALLOUT NUCLIDES DERIVED FROM THE CHERNOBYL REACTOR ACCIDENT USING HIGH-PURITY GERMANIUM DETECTOR

K.Terai, K. Fujii, M. Nakazawa*, T. Hamada** and K. Komura***

Shimane Pref. Inst. for Public Health and Env. Sci., Nishiharasada, Matsue 690-01

* Faculty of Engineering, Univ. of Tokyo, Hongo, Bunkyo, Tokyo 113

** Japan Radioisotope Association, Motokomagome, Bunkyo, Tokyo 113

*** I.I.R.L., Kanazawa Univ., Wake, Tatsunokuchi, Ishikawa 923-12
JAPAN

1. Introduction

Fallout nuclides derived from the Chernobyl reactor accident (from now on CRA) in April 26 of 1986, were detected at Matsue in Shimane Prefecture (SW Japan located about 7,800 km East from Chernobyl reactor site) in rain water and airborne particles collected in May 4 (local time). The Shimane Prefectural Institute for Public Health and Environmental Science (SPI) started monitoring of the effect of CRA mainly by non-destructive gamma-ray spectrometry of various environmental samples collected from entire area in Shimane. Details of this observation will be given in the Science Report of SPI¹⁾. Besides the laboratory measurement of the samples collected, in-situ gamma spectrometry using high purity Ge detector was performed from May 9 to early July. This paper describes the results of in-situ measurement of the effects of CRA.

2. Measurement and Data Analysis

Two portable Ge detectors were used for in-situ measurement of gamma-ray spectrum. One is a Ge detector with efficiency of 40.5% relative to a 3"x3" NaI(Tl) detector and 1.77 keV of energy resolution (FWHM) at 1.33 MeV, and the other is a Ge detector with relative efficiency of 7.2 %. Techniques of data analysis of in-situ measurement for obtaining dose rate and/or accumulation of fallout nuclides is almost the same as the method developed by Beck et al²⁾. The Ge detector was set facing down 1 m above the ground surface, and gamma-ray spectrum was measured for 1 to 2 hours. To compare the result obtained by in-situ measurement with those by soil sampling method, surface soils of 0 - 21 cm were collected at 3 cm intervals just below the Ge detector.

About 200 measurements were made from May 9 to early July. Gamma-ray spectra were analyzed by an automatic peak search program. The dose rates for the fallout nuclides derived from CRA together with those for natural radionuclides belonging to the U- and Th-series and K-40 were calculated by multiplying the count rate of gamma-ray peaks with conversion factors obtained for each Ge detector. Depth profile of Cs-137 accumulated in surface soil before CRA was simulated by an exponential function given by $A_x = A_0 \exp(-\alpha x)$, where A_0 and A_x are the Cs-137 activity at soil surface and depth x , respectively. The α is a fitting parameter of depth profile. The α value obtained by the analysis of the soil samples ranged from 0.4 to 0.9 cm^{-1} . Detail of the calibration method of the Ge detectors will be described elsewhere¹⁾. The density of surface soil was measured to be 1.5 - 1.6 g/cm^3 , therefore, 1.6 g/cm^3 was adopted in the calculation of conversion factors.

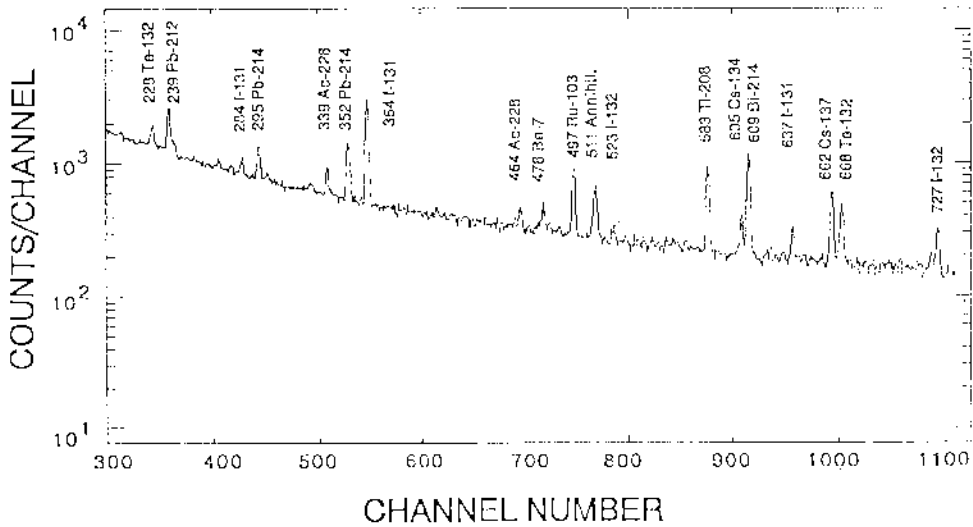

Fig. 1. In-situ gamma-ray spectrum of 200 - 700 keV region measured at 12:00 to 14:00 of May 9, 1986. Measuring time and gain setting were 120 min and 0.667 keV/ch, respectively.

3. Results and Discussion

In-situ gamma-ray spectrum obtained in May 9, 1986, is shown in Fig. 1. Fallout nuclides identified are Te-132 (228, 668 keV), I-131 (284, 364, 637 keV), Ru-103 (497 keV), I-132 (523, 727 keV), Cs-134 (605, 795 keV) and Cs-137 (662 keV). Results of analyses of In-situ measurements are summarized in Tables 1, and 2, and the time variations of dose (exposure) rates of Cs-137, I-131 and Ru-103 are shown in Figs. 2 to 4.

[Cs-137] Dose rate and/or accumulation of Cs-137 was calculated by assuming the depth profile of Cs-137 being exponential and/or exponential + surface distribution before and after CRA, respectively. Contribution of nuclear weapons tests is shown by a dotted line in Fig. 2. Accumulation of Cs-137 at the measuring point is order of magnitude lower than the value measured at typical uncultivated area in Shimane, because the construction of the SPI building begun in 1975. Accumulation of Cs-137 in surface soil begun since that year. As known from Fig. 2, dose rate has increased from 0.15 to 0.32 uGy/h by CRA. Appreciable increase of dose rate was not found after the initial increase during early May, because most of Cs-137 had fallen in a short time during this period. If in-situ measurements were made at uncultivated area with high amount of Cs-137, such a small increase of dose rate could not precisely be evaluated by in-situ measurement. Accumulation of Cs-137 estimated by in-situ measurement agreed well with soil sampling method within 15%. Increase of Cs-137 accumulation by CRA was estimated to be about 70 MBq/km² at Matsue.

Table 1. Dose and accumulation of Cs-137 before and after CRA.

Measured Date	Dose (nGy/h)		Accumulation (MBq/sq.km)		Depth profile used in the calculation
	Average	Range	Average	Range	
Before CRA	0.156	[0.119 - 0.186]	110	[87 - 123]	Exponential
After CRA	0.324	[0.257 - 0.366]	180	[153 - 196]	Exponential + Surface

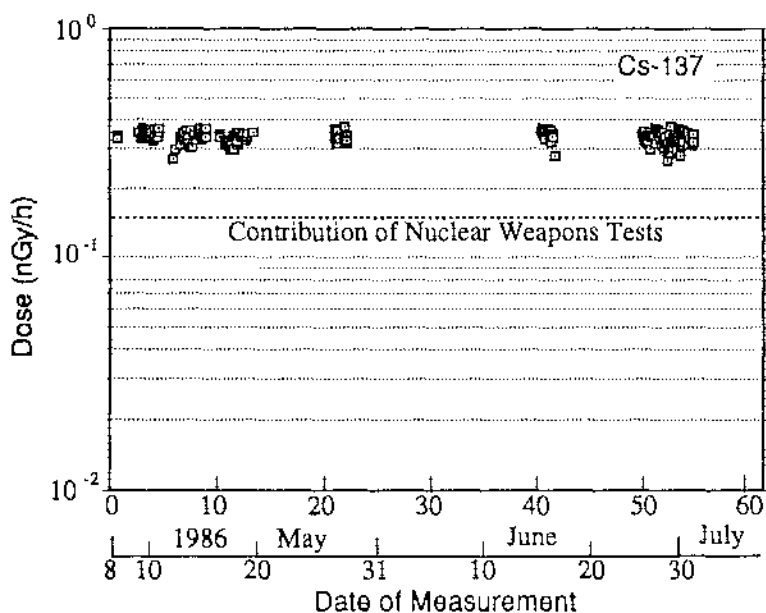

Fig. 2. Variation of dose rate due to fallout Cs-137 measured at Matsue.

[I-131] Dose rate and accumulation of I-131 at May 9 were calculated to be 0.918 nGy/h and 536 MBq/km², respectively, by assuming surface distribution ($\alpha = \text{infinity}$) on the ground. As shown in Fig. 3, apparent half-life of I-131 in an early stage (May 9 to 20) was evaluated to be 12.8 days, however, after this period, it became 7.9 days, which corresponds to the physical half-life of 8.06 d. Concentration of I-131 in the surface air measured by high volume air-sampler showed two peaks in May 8 (before the beginning of in-situ measurement) and May 13 (1/4 of that observed in May 8). Longer apparent half-life of I-131 in early stage might be explained by the delay of the deposition of I-131 (compared with other fallout nuclides), because significant fraction of I-131 was found to be in gaseous state as evidenced by the sampling with charcoal filter, and partly by the contribution of second plume observed in May 13. Integral dose due to I-131 during May 8 (when maximum air concentration was observed) through the beginning of July was estimated to be 338 nGy.

[Ru-103] As shown in Fig. 4, apparent half-life of Ru-103 was calculated to be 36.8 days, which is a little shorter than the physical half-life of 39.6 days. This may be explained by the downward migration of Ru-103 due to the rain fall during this period. Dose rate and accumulation of Ru-103 estimated for May 9 are 0.305 nGy/h and 140 MBq/km², respectively. Integral dose due to Ru-103 was calculated to be 436 nGy, which is little higher than that of I-131.

Dose rate due to Cs-137 measured after 8 months of CRA was 0.28 nGy/h, which is 4/5 of that measured at Ibaraki Prefecture (0.35 nGy/h), located 700 km East of Shimane.

Table 2. Dose, accumulation, integral dose and apparent half-life of fallout nuclides.

Nuclide	May 9, 1986		Integral Dose (nGy)	Apparent Half-life
	(nGy/h)	(MBq/sq.km)		
Cs-137	0.318	177	0.32 x hour	>1000d
I-131	0.918	536	338	12.8 d (until May 20) 7.9 d (after May 20)
Ru-103	0.305	140	436	36.7 d

References

1. K. Terai et al. Ann. Rep. Shimane Pref. Inst. Public Health and Env. Sci., in preparation.
2. H. L. Beck et al, HASL 258 (1972).

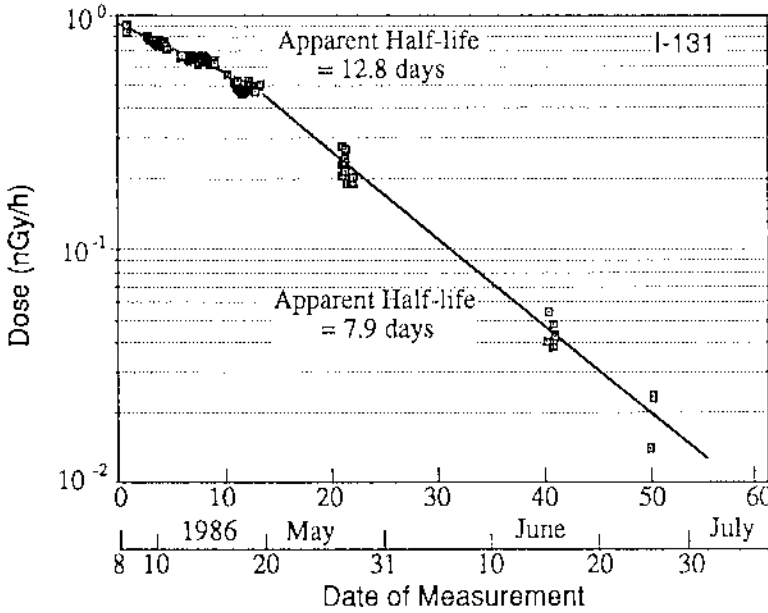

Fig. 3. Variation of dose rate due to fallout I-131 measured at Matsue.

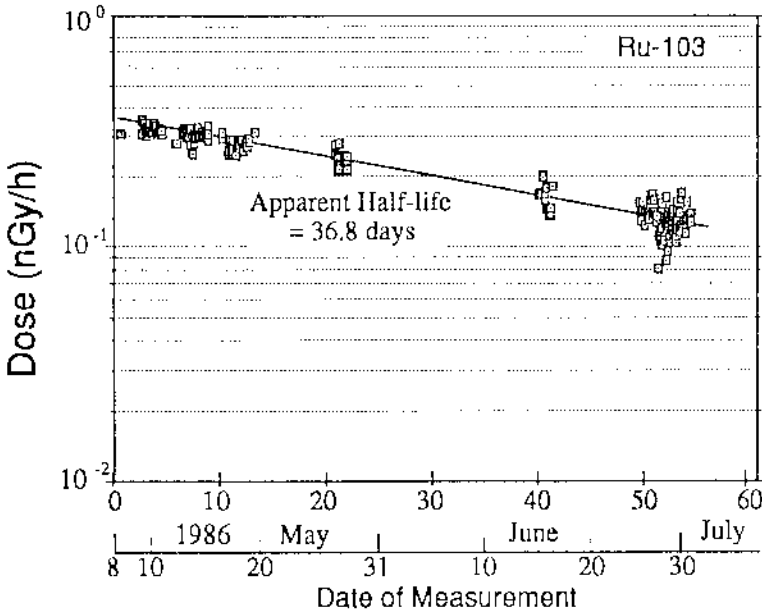

Fig. 4. Variation of dose rate due to fallout Ru-103 measured at Matsue.

COMPARISON OF MEASURED RADIOECOLOGICAL PARAMETERS IN
AACHEN AFTER THE CHERNOBYL ACCIDENT WITH VALUES USED IN THE
FEDERAL REPUBLIC OF GERMANY

H. Bonka

Lehrgebiet Strahlenschutz in der Kerntechnik,
RWTH Aachen.

ABSTRACT

After the nuclear reactor accident at Chernobyl it was possible just like after the nuclear weapon tests to measure important radioecological parameters. It could be explained why the transport of I 131 from air into milk was overestimated by a factor of approx. 5 due to the used compartment model. The most important measured parameters in Aachen are stated.

INTRODUCTION

The calculation method as well as the applied data for the calculation of the radiation exposure of the population in the vicinity of nuclear plants are fixed in licensing procedures of the government in the Federal Republic of Germany¹. At the time, when the nuclear reactor accident happened in Chernobyl, the regulation had to be modified because of the amendment of the radiation protection regulation. As an example, Fig. 1 shows the compartment model to calculate the transport of the radionuclides without H 3 and C 14 from air into the edible part of plants and of pasture grass into milk and meat. For licensing procedures the food groups leafy vegetables, non-leafy vegetables, cow's milk and beef are taken into consideration.

DEPOSITION VELOCITY

From May 1st 1986 until the evening of May 3rd 1986 radionuclides were deposited in Aachen only due to dry deposition. The deposited aerosolbound activity on grass increased continuously whereas the I 131 activity showed two peaks before the first rainfall². The first peak most probably results from the change of air activity. The second peak can be caused by the sorption and desorption due to dewfall during the night. Taking into account the activity concentration in air a deposition velocity of 0.025 to 0.11 cm/s with a mean value of 0.07 cm/s results for the aerosolbound Cs 137 on 10 to 15 cm high grass. Without taking into account the two peaks, the deposition velocity for the total I 131 lies between 0.13 and 0.17 cm/s. For the peaks the deposition velocity amounts to 0.28 cm/s. Referring to elemental iodine only, a mean value of approx. 0.7 cm/s results. For the new licensing procedures in the Federal Republic of Germany¹ the deposition velocity for aerosolbound radionuclides was enhanced from 0.1 to 0.15 cm/s. For elemental iodine a value of 1 cm/s is still used. For aerosolbound radionuclides however, the size distribution of the particles must be considered. Since about two years Cs 134 can be used to measure the higher deposition velocity in forests compared to the deposition velocity on grass. Values result which are 3 to 8 times higher.

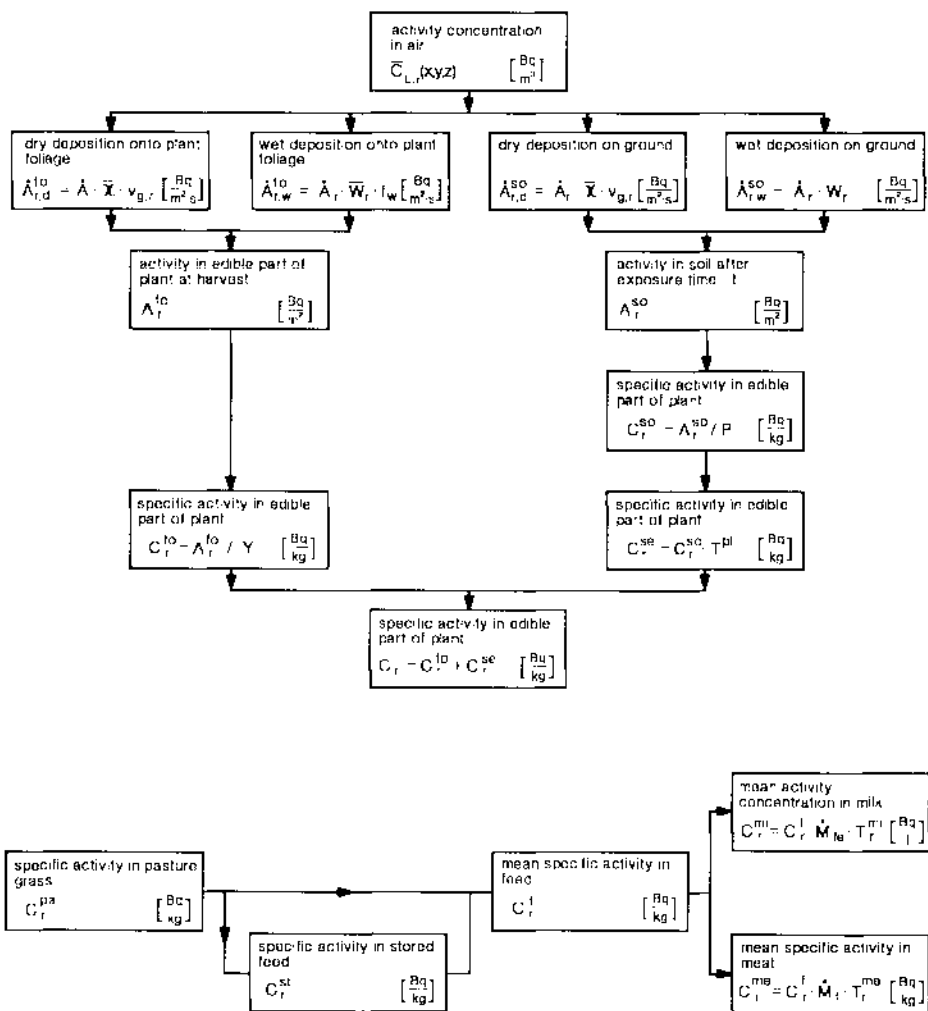

Fig. 1: Compartment model to calculate the transport of radionuclides in nourishment at air pathway

WASHOUT COEFFICIENT AND RETENTION FACTOR ON GRASS

During two rain events on May 3rd 1986 of 0.25 mm and 0.95 mm on May 5th 1986, the washout ratio in dependence of the rain intensity I could be measured. Assuming the activity concentration to be constant over the height, a value can be derived which is comparable to the washout coefficient². This value increased during the first rain event with $(I/I_0)^{0.74}$ and at the second with $(I/I_0)^{0.56}$. According to the licensing procedures¹ the washout coefficient A can be calculated for aerosolbound radionuclides and elemental iodine to $7 \cdot 10^{-5} \text{ s}^{-1} \cdot (I/I_0)^{0.8}$. The measured retention factor lies between 0.2 and 0.6 with a mean value of approx. 0.4. In reference¹ the f_w value was enhanced from 0.2 to 0.3.

HALF LIFE FOR THE REMOVAL OF ACTIVITY ON PLANTS

When the activity concentration in the air became neglectable, the half life for the removal of the activity on grass due to weathering could be determined by measuring the deposited activity per unit ground area. A half-life of approx. 10 days results for I 131, one of approx. 14 days for Cs 134 and Cs 137. A value of 8 days results for Ru 103. In reference¹ a value of 14 days was defined for all radionuclides.

TRANSFER FACTOR FOOD-MILK

The determination of the transfer factor food milk for I 131 showed the most important result. In the frame of licensing procedures a value of 0.01 d/l was used. It was obvious for all scientists working in the field of radiocology that using this value and the above mentioned deposition velocity the transfer of I 131 from air into milk was overestimated by a factor of 5. Measurements in cow's milk of one smaller and four larger farms showed in May and June 1986 a I 131 transfer factor of approx. 0.002 d/l and an effective removal rate constant of approx. 0.6 d⁻¹. For Cs 137 a value of approx. 0.003 d/l results for the transfer factor as well a value of approx. 0.4 d⁻¹ for the removal rate constant³. The transfer factor increased during the grazing period to approx. 0.007 d/l, if only taking into account the specific activity in grass that was cut approx. 1 cm above soil. Tests showed that this was caused by the additional activity of cows which partly tore grass roots and took in soil as well⁴. For licensing procedures¹ the transfer factor food milk for I 131 was lowered to 0.003 d/l and for Cs 137 from 0.012 d/l to 0.005 d/l.

TRANSFER FACTOR FOOD-BEEF

In order to determine the transfer factor food beef the specific activity in beef was measured in detail from 1986 until 1990. When comparing the specific Cs 137 activity in beef with the activity concentration in cow's milk of 3 farms it can be seen that the value in beef is approx. 6 times higher. According to this the transfer factor lies between 0.015 and 0.04 d/kg. In licensing procedures¹ the transfer factor was already increased from 0.004 to 0.03 d/kg in 1982. This step was right according to the measured values.

TRANSFER FACTOR SOIL GRASS

Soil and grass samples were taken over the whole Federal Republic of Germany in order to analyze the local and temporary variability of the transfer factor soil-grass after a single contamination. Table 1 shows the measured values. In licensing procedures¹ a value of 0.05 is used.

Table 1: Measured transfer factor soil-grass

	1987		1988		1989		1990	
	Cs 134	Cs 137	Cs 134	Cs 137	Cs 134	Cs 137	Cs 134	Cs 137
mean value	0.21	0.19	0.077	0.055	0.043	0.038	0.044	0.037
Maximum value	2.8	2.6	0.75	0.57	1.13	0.85	0.21	0.18
number of samples	79	82	39	41	94	96	50	57

SPECIFIC CS 134- AND CS 137-ACTIVITY IN HUMAN BODIES

Parallel to the very detailed determination of the specific activity in food in Aachen the specific Cs- activity in bodies of adults was measured gammaspectrometrically. Assuming realistic alimnetation habits a very good agreement can be stated between calculation and measurement⁵ for an effective half life of 110 days as shown in Fig. 2.

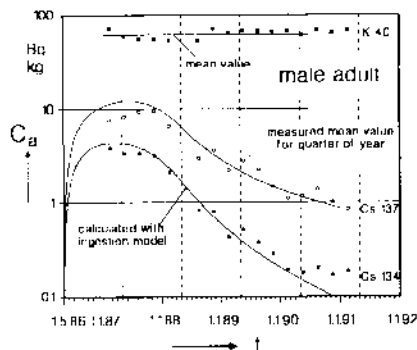

Fig. 2: Measured mean specific activity of Cs 134, Cs 137 and K 40 in arms of male adults in Aachen compared with calculated values

REFERENCES

1. BMU, 1990, Allgemeine Verwaltungsvorschrift zu §45 Strahlenschutzverordnung, Bundesanzeiger, 42, 31. März 1990
2. Bonka, H., Horn, H.-G., Maqua, M., 1988, Measured Deposition Velocities and Rainout Coefficients after the Chernobyl Accident Compared with Theoretical Models and Experimental Data, IRPA 7, 660-663
3. Bonka, H., Küppers, J., Maqua, M., 1988, Measured Transfer Factors in Milk and Meat after the Chernobyl Reactor Accident, IRPA 7, 1474-1477
4. Bonka, H., 1989, Measured Radiocological Parameters after the Chernobyl Accident, in: The Radioecology of Natural and Artificial Radionuclides, Ed. by Feldt, TÜV Rheinland, Köln, 147-152
5. Kreh, R., Bonka, H., 1991, Messung der Cs 134- und Cs 137- Aktivität bei erwachsenen Personen aus Aachen nach dem Kernreaktorunfall in Tschernobyl, in: Strahlenschutz für Mensch und Umwelt, Ed. by Jacobs, Bonka, TÜV Rheinland, Köln, 920-925

ACKNOWLEDGEMENT

This measurements were sponsored by the Bundesminister für Umwelt, Naturschutz und Reaktorsicherheit of the Federal Republic of Germany.

MECHANISMS OF CESIUM TRANSFER IN FOREST ECOSYSTEMS OBTAINED FROM CONTINUOUS MONITORING OF ROEDEER CONTAMINATION

G. Zibold¹, J. Drissner¹, W. Erb¹, Th. Herrmann², M. Hund¹, G. Lindner¹, Ch. Wilhelm¹, J. Wolf¹, W. Zech²

¹Institut für Innovation und Transfer, Fachhochschule Ravensburg-Weingarten, D-7987 Weingarten; ²Lehrstuhl für Bodenkunde und Bodenographie, Universität Bayreuth, D-8580 Bayreuth

ABSTRACT

At a roedeer population from a prealpine forest area (1600 km²) periodic contamination maxima in autumn, a slow overall decrease with an effective ecological half-time of 2,6 +/- 0,4 years and a regional pattern with characteristic small-scale variations representing the transfer of Cs radionuclides from the soil to the animals are observed. The depth distribution of Cs radionuclides in the layered forest soil is peaked in the uppermost humic layer and it is inferred that binding to organic substances plays an important role in the fixation of these radionuclides. This is corroborated by observations in a highmoor, where the shape of the depth distribution and the transfer to plants turned out to be rather similar to those of forest soils and at fertilized forest areas, where the transfer factor was significantly reduced.

INTRODUCTION

In the glacially formed prealpine region of Oberschwaben in the south west of Germany the contamination with Chernobyl fallout is among the highest in central Europe. The specific activity of Cs radionuclides in roedeer from this area, grazing mainly in forests, is higher than for other animal species and decays only slowly in time /1/. Additionally it exhibits a characteristic seasonal structure /1,2/, which was similarly observed for roedeer from Sweden /3/ and from Bavaria /4/, and a small-scale regional structure, which was well reproduced over several years. We propose that these structures are related to the particular type of speciation of Cs radionuclides in layered forest soils, in particular to their association with organic substances in the uppermost humic layer /5-9/.

RESULTS AND DISCUSSION

In collaboration with local forest authorities the specific activities of Cs-137 and Cs-134 in most of the roedeer shot in this area - about 800 samples per year - have been measured gamma-spectrometrically since 1987. The time dependence of the roedeer contamination - in fig. 1 the arithmetic mean over two weeks is shown - exhibits periodic contamination maxima in autumn, which are correlated with the well-defined season of mushrooms. Several mushroom species - among them the abundant edible species chestnut boletus (*xerocomus badius*) - have extraordinarily high cesium transfer factors /1/ and mushrooms are part of the diet of roedeer in autumn /3/. Therefore grazing of mushrooms is considered to be mainly responsible for the steep increase of roedeer contamination in autumn and its subsequent decrease is due to the abrupt end of the mushroom season. An additional reason for the in-

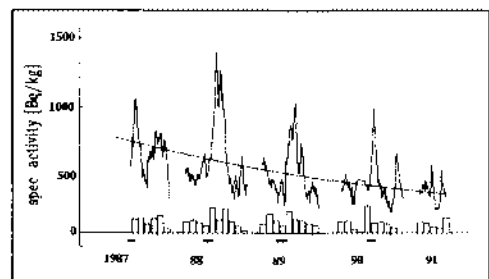

fig. 1: Specific activity of Cs-137 in roedeer meat versus time. Amount and season of mushrooms is indicated on the time scale.

creased contamination levels may be the general increase of roe deer intake in autumn /4/. The overall effective ecological half-time of the specific Cs-137 activity in the roe deer population, obtained from an exponential least-squares fit to all existing data for 4 years of monitoring, is 2.6 ± 0.4 years.

Within this rather small and geologically uniform region (glacially formed moraines) the radiocesium (Cs-134 and Cs-137) contamination levels of individual animals varied widely between less than 10 and more than 3000 Bq/kg. The regional distribution of the contamination (individual animals were attributed to the sites of shooting), on the other hand, appeared to be stable over several years exhibiting small areas with groups of animals showing substantial contamination (fig. 2). Taking into account the restricted grazing areas of individual animals it is proposed that this contamination pattern reflects the pattern of local transfer factors from soil to roe deer via grazing plants. This was studied in detail in the largest forest of this area with a spatial resolution of $0,5 \times 0,5 \text{ km}^2$, where differences of about a factor 50 in local transfer factors soil-roe deer were obtained between the northern and southern part of this forest (fig. 3).

These observations can be explained by (i) local variations of the availability of Cs radionuclides in the forest soils for the uptake by grazing plants or (ii) local changes of the abundances of grazing plants with different plant-specific transfer efficiencies. Since a similar pattern was obtained for the transfer factors soil-blackberry (fig. 4), we conclude that the type of binding of Cs radionuclides in the forest soils, i. e. the bioavailability in soil, is of major importance for the

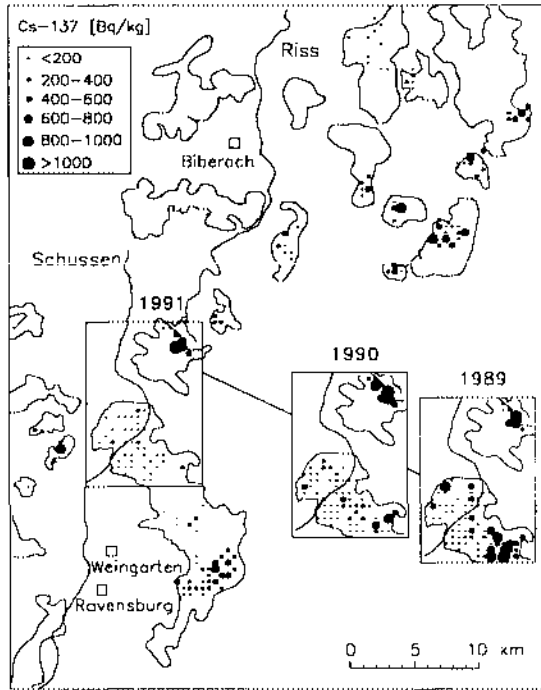

fig. 2: Regional distribution of specific Cs-137 activity of roe deer in southern Germany 1991. Inset shows the years 90 and 89. Each dot represents the average value of samples from an area of $0,5 \times 0,5 \text{ km}^2$.

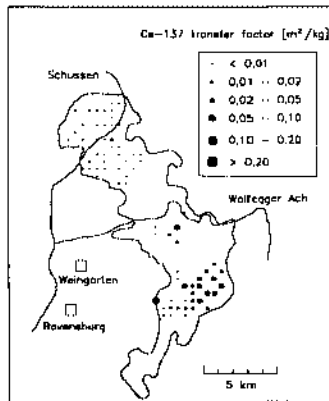

fig. 3: Cs-137 transfer factor soil-roe deer for the forest area Altdorfer Wald. Samples taken 1991. Dot represents contamination as in fig. 2.

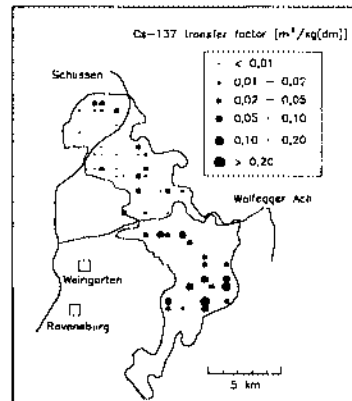

fig. 4: Cs-137 transfer factor soil-blackberry measured 1991.

contamination pattern.

The investigation of the depth distribution of Cs radionuclides in the soil of this forest revealed a high fraction of Cs radionuclides from the Chernobyl fallout still present in the uppermost humic layer of the soil, i.e. not deeper than 4 cm, in accordance with results for several other European forests /6-9/. A depth profile obtained from a sampling side in Altdorfer Wald is shown in fig. 5 together with the layering of the soil. Since the uppermost soil layer mainly consists of organic substances we presume a rather strong binding of Cs to organic substances, which prevents Cs radionuclides from transport to larger depths. This is in accordance with the results of laboratory experiments showing a high retention of Cs in O horizons /5/. The transfer factors soil-plant in this forest vary with the thickness of both O and A₁ horizons showing highest values for total thicknesses as low as 2 cm (fig. 6), which emphasizes the importance of a well-developed O horizon for Cs immobilization. Another corroboration comes from depth profiles and transfer factors to plants measured in sphagnum bogs of this region. Despite of the lack of mineral components and layering of these soils, the shape of the depth profile in these soils is quite similar to that in forest soils (apart from an extension towards greater depths, fig. 7) and transfer factors soil - plants do not differ as much for plant species growing both in forest and sphagnum bogs /2/.

As a consequence organically bound Cs radionuclides will be remobilized by the decomposition of their organic carriers as proposed by Dörr and Münnich /10/ and thus become available for the uptake by plants. Thus this system is very sensitive to changes of the chemical milieu, which can e.g. be induced by fertilizer treatment of the forest soil. Correspondingly, on a forest area treated with a fertilizer consisting mainly of CaCO₃ prior to the Chernobyl contamination, the transfer factor for several plants is significantly reduced as compared to a neighbouring untreated forest area (fig. 8). This effect might be explained by (i) the known faster decomposition of organic matter after liming inducing higher concentrations of ions in the soil solution; (ii) the definition of the transfer factor itself: the above-ground biomass of the bottom layer plants regarded on the limed field exceeds the biomass on the control area considerably; or (iii) an enhancement of Cs association with organic matter.

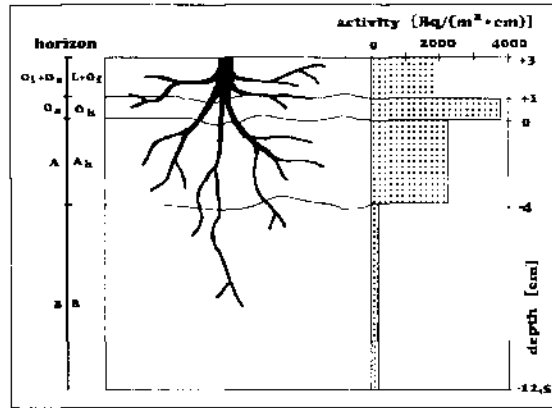

fig. 5: Layering of soil horizons and Cs-137 depth profile in a forest soil from Altdorfer Wald (20.12.90).

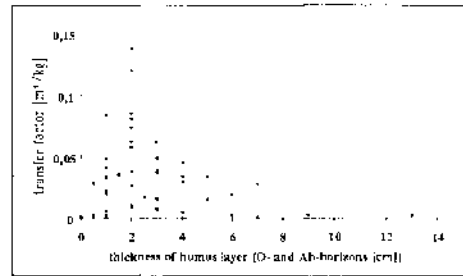

fig. 6: Cs-137 transfer factor soil-blackberry versus thickness of humus layer (O- and A₁-horizons).

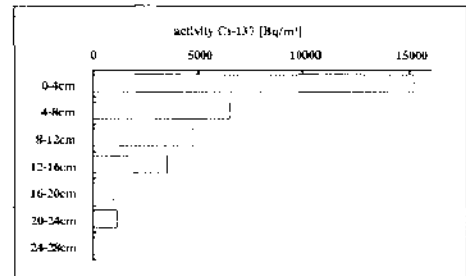

fig. 7: Depth profile of Cs-137 in sphagnum bog of Brunnenholzried.

CONCLUSION

The observed seasonal and regional structures in the radiocesium contamination of the roedeer population of a prealpine forest (picea abies) area emphasize the importance of the organic speciation of Cs radionuclides from the Chernobyl fallout in forest soils with respect to transfer processes.

The support of the Ministry of Environment of the State Baden-Württemberg is gratefully acknowledged.

REFERENCES

- /1/ Zibold, G., Geissler, A., Kissling, S., Niebuhr, J., Wilhelm, C.: Radiocesium in roedeer from the South of West-Germany, Proc. XVth Regional Congress of IRPA "The Radioecology of Natural and Artificial Radionuclides" (W. Feldt, ed.), Verlag TÜV Rheinland, Köln, p.268-273 (1989).
- /2/ Zibold, G., Drissner, J., Erb, W., Herrmann, Th., Hund, M., Lindner, G., Schodlock, H.-J., Wilhelm, Ch. und Wolf, J.: Transferprozesse von Cäsium-Radionukliden in Waldökosystemen, in H. Jakobs and H. Bonka (Hrsg.): Strahlenschutz für Mensch und Umwelt, Verlag TÜV Rheinland, Köln, p. 247-252 (1991).
- /3/ Karlen, G., Johanson, K.J., Bergström, R.: Seasonal variation in concentration and daily intake of Cs-137 in Swedish roedeer, J. Environm. Radioact. (in press).
- /4/ Fielitz, U.: Radiocäsium in Waldökosystemen 1987 - 1990, in H. Jakobs and H. Bonka (Hrsg.): Strahlenschutz für Mensch und Umwelt, Verlag TÜV Rheinland, Köln, p. 241-246 (1991).
- /5/ Thiry, Y. and Myttenaere, C.: Study on the Bioavailability of Radiocesium Following Contamination of the Forest Floor, in Proc. Seminar on Comparative Assessment of the Environmental Impact of Radionuclides Released during Three Major Nuclear Accidents: Kyshtym, Windscale, Chernobyl, Commission of the European Communities, p. 1089-1100 (1991).
- /6/ Bunzl, K., Schimmack, W., Kreuzer, K and Schierl, R.: The Migration of Fallout ^{134}Cs , ^{137}Cs and ^{106}Ru from Chernobyl and of ^{137}Cs from weapons testing in a forest soil, Z. Pflanzenern. Bodenk. 152, p. 39-44 (1989).
- /7/ Andolina, V. and Guillitte, O.: Radiocesium Availability and Retention Sites in Forest Humus, in Desmet, G., Nassimbeni, P. and Belli, M. (eds.): Transfer of Radionuclides in Natural and Semi-Natural Ecosystems, Elsevier, Barking, p. 135-142 (1990).
- /8/ Römmelt, R., Hiersche, L., Schaller, G. and Wirth, E.: Influence of Soil Fungi (Basidiomycetes) on the Migration of Cs-134 + 137 and Sr-90 in Coniferous Forest Soils, in Desmet, G., Nassimbeni, P. and Belli, M. (eds.): Transfer of Radionuclides in Natural and Semi-Natural Ecosystems, Elsevier, Barking, p. 152-160 (1990).
- /9/ Block, J. and Pimpl, M.: Cycling of Radiocesium in two Forest Ecosystems in the State of Rhineland-Palatinate, in Desmet, G., Nassimbeni, P. and Belli, M. (eds.): Transfer of Radionuclides in Natural and Semi-Natural Ecosystems, Elsevier, Barking, pp. 450-458 (1990).
- /10/ Dörr, H. and Münnich, K.O.: Downward Movement of Soil Organic Matter and its Influence on Trace-Element Transport (^{210}Pb , ^{137}Cs) in the Soil, Radiocarbon 31 (3), p. 655-663 (1989).

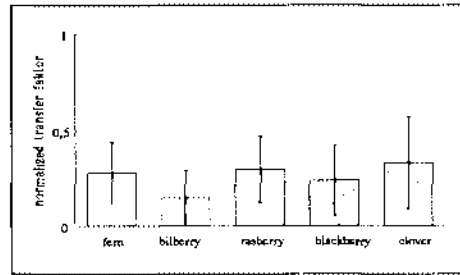

fig. 8: Relative reduction of Cs-137 transfer due to fertilizer for different plants from forest soil treated with a fertilizer containing 83% CaCO_3 . The normalization is with respect to untreated soil.

SUIVI DE LA CONTAMINATION EN CESIUM 137 DE CHAMPIGNONS DANS UNE
REGION FRANCAISE APRES L'ACCIDENT DE TCHERNOBYL

N. BROQUET¹, A. CHAMBAUDET², J.P. CHAUMONT¹,
D. KLEIN² ET J. SIMERAY¹

1- Laboratoire de Botanique et de Cryptogamie, Faculté de
Médecine et de Pharmacie, Université de Franche-Comté,
25000 Besançon, France

2- Laboratoire de Microanalyses Nucléaires, U.F.R. des
Sciences et de Techniques, Université de Franche Comté,
25030 Besançon, France

A STUDY OF CONTAMINATION IN CESIUM 137 IN MUSHROOMS
IN FRENCH REGION AFTER CHERNOBYL ACCIDENT

After the accident at Chernobyl on 26 April 1986, we have
study the radiocontamination of 36 species of fungus gathered in
1988 and 1989 on 17 sites in eastern France (Franche-Comté). The
species selected based on their biological characteristics, were
analyzed by gamma spectrometry. 25% of species contained amounts
of Cesium 137; for 8% exceeded the level of 600 Bq.Kg⁻¹ of fresh
matter. 75% of the species mycorrhizal, 25 were saprophytes.
Edible species showed little or no contamination.

INTRODUCTION

Après l'accident de Tchernobyl, des mesures ont été
effectuées sur différents champignons dans quelques pays touchés
par le nuage radioactif en mai 1986 (1, 3, 4).

En France, des mesures ponctuelles, effectuées çà et là
(2), ont montré que dans certains cas les accumulations de
cesium 137 dans les carpophores étaient loin d'être négligeables.
La région de Franche-Comté (Est de la France) fut touchée par le
nuage radioactif durant le mois de mai 1986.

Il était important de connaître comment les champignons
avaient fixé les éléments radioactifs ambiants et surtout s'ils
présentaient un danger à la consommation.

MATERIEL ET METHODES

- Choix des espèces et des sites de récolte

Nous avons choisi les espèces en fonction de leur position
taxonomique et de leurs caractéristiques biologiques.

Les échantillons ont été récoltés sur 16 sites en Franche-
Comté, déterminés en fonction de leurs caractères écologiques
(altitude, exposition, sol, microtopographie, végétation).

- Méthodes de mesures

Chaque échantillon broyé et séché est placé dans une cellule standard pour le dosage précis de la quantité de césium 137 contenue.

La mesure de ce radionucléide est réalisée sur une chaîne de mesure étalonnée de spectrométrie gamma (Ge(Li)).

L'ensemble des résultats (tableau 1) est présenté en Becquerel par kilo de matière fraîche ou sèche (Bq/kg). L'erreur relative dans la plupart des cas est égale à 10 %.

ESPECE	DATE DE RECOLTE	contamination en césium 137 exprimée en Becquerels		ESPECE	DATE DE RECOLTE	contamination en césium 137 exprimée en Becquerels	
		par kilo de matière fraîche	par kilo de matière sèche			par kilo de matière fraîche	par kilo de matière sèche
<i>Agaricus campester</i> C.S.	19/11/88 21/09/89 22/08/89 12/10/89	0 0 0 0	0 0 0 0	<i>Laccaria amethystina</i> C.S.	4/10/88	0	0
<i>Agaricus hortensis</i> C.S.	13/10/89	0	0	<i>Laccaria laccata</i> C.S/M	4/10/88 13/10/88	0 0	0 0
<i>Amanita citrina</i> SIC.M.	4/10/88 12/11/88	0 115	0 1133	<i>Lactarius deterrimus</i> SIC.M.	12/11/89 19/11/88 20/11/88	0 429 0	0 376 0
<i>Amanita muscaria</i> T.M.	20/11/88	0	0	<i>Lactarius salmonicolor</i> C.M.	17/09/89 6/10/89	0 0	0 0
<i>Amanita rubescens</i> C.M.	20/11/88	0	0	<i>Lactarius vellereus</i> SIC.M.	3/09/89	0	0
<i>Boletus edulis</i> C.M.	4/10/89 9/10/89	0 0	0 0	<i>Lepista nebularis</i> C.S.	19/11/88 12/11/88	0 0	0 0
<i>Calocybe gambusa</i> C.S.	14/04/89	0	0	<i>Lycoperdon perlatum</i> SIC.S.	20/11/88	0	0
<i>Cantharellus cibarius</i> C.M.	4/10/88 19/11/88 3/09/89 17/09/89	0 0 0 0	0 0 0 0	<i>Marasmius conicus</i> C.S.	25/03/89	0	0
<i>Cantharellus tubaeformis</i> C.M.	19/10/88 15/10/89 19/11/88 3/01/89	7 129 26 6	70 1000 767 71	<i>Piptoporus betulinus</i> SIC.P.	2/02/89 2/10/89	0 0	0 0
<i>Collybia peronata</i> SIC.S.	13/11/88	3236	39663	<i>Pleurotus ostreatus</i> C.S.	19/11/88	0	0
<i>Cortinarius eumyces</i> "	20/11/88	2470	13443	<i>Ramaria abietina</i> SIC.S.	12/11/88 20/11/88	9 409	35 3192
<i>Cortinarius hirsutulus</i> "	23/11/88	0	0	<i>Russula cyanoxantha</i> C.M.	7/10/89	24	239
<i>Cortinarius versicolor</i> "	3/10/89	0	0	<i>Sarcoscypha coccinea</i> C.S.	9/03/89	0	0
<i>Craterellus cornucopiosus</i> CM.	13/11/88 12/10/89	0 0	0 0	<i>Strobilomyces floccopus</i> SIC.M.	4/10/88	0	0
<i>Crepidotus variabilis</i> SIC.S.	20/11/88	0	0	<i>Suillus luteus</i> C.M.	25/10/89	75	1013
<i>Cystoderma amianthinum</i> SIC.M.	20/11/88	1289	18149	<i>Tricholoma supinaeum</i> C.M.	12/10/89	0	0
<i>Hydnum repandum</i> C.M.	12/11/88 12/11/88 3/09/89	0 0 90	0 0 356	<i>Xerocomus chrysenteron</i> C.M.	4/10/88 19/11/88	0 180	0 2766
<i>Hypoloma sublateritium</i> T.S.	12/11/88 13/11/88	0 0	0 0	<i>Xylaria polymorpha</i> SIC.S.	12/10/89	0	0

C : comestible SIC : sans intérêt culinaire T : toxique S : saprophyte M : Mycorrhizique P : parasite

TABLEAU 1 : Ensemble des résultats d'analyse

RESULTATS ET DISCUSSION

En tout, 60 mesures concernant 36 espèces réparties sur 16 sites ont été réalisées. Ces résultats révèlent que 30% des

espèces analysées sont plus ou moins contaminées par le césium 137.

Parmi celles-ci 8% dépassent le taux de 600 Bq/kg de matière fraîche, limite recommandée par la CEE pour la concentration en césium 137 dans les aliments non laitage; ce sont par ordre de valeurs décroissantes: *Collybia peronata*, *Cortinarius cyanopus*, *Cystoderma amianthinum*.

Les champignons mycorrhiziques sembleraient plus exposés à la contamination puisque 75% d'entre eux montrent des taux d'imprégnation significatifs, alors que seuls 25% des saprophytes sont touchés. Parmi ces derniers les espèces, dont le mycelium se développe au dépend des litières superficielles, absorbent une grande quantité d'éléments radioactifs. Par contre les champignons, dont le mycelium est au contact des couches humifères plus profondes, sont dénués de radioactivité (*Laccaria amethystina*).

La seule espèce parasite enviaagée est négative vis à vis de nos tests.

Les champignons lignicoles, qu'ils soient parasites ou saprophytes, semblent exempts de cesium 137 (*Piptoporus betulinus*, *Hypholoma sublateritium*, *Xylaria polymorpha*, *Crepidotus mollis*).

Un autre aspect à considérer est celui de l'ouverture des milieux. Les taxa des milieux ouverts (praticoles) semblent exempts de radioactivité.

En ce qui concerne l'évolution du taux de radioactivité dans le temps, nous avons constaté pour *Cantharellus tubaeformis*, une valeur plus importante en 1989 qu'en 1988 pour des exemplaires récoltés dans la même station.

Le problème de la radiocontamination des espèces comestibles est évidemment important pour le public. Dans cette étude, on constate que les espèces les plus contaminées ne sont pas comestibles ou sont dénuées de tout intérêt culinaire.

Cependant, *Cantharellus tubaeformis*, *Hydnum repandum*, *Russula cyanoxantha*, espèces comestibles, ne sont pas totalement dépourvues de surcharge radioactive, bien que leurs teneurs ne dépassent pas le seuil de 600 Bq/kg de matière fraîche. Il est à signaler que l'impact radiologique de ces espèces reste faible au regard des consommations nécessaires pour atteindre la limite annuelle d'incorporation (L.A.I.), qui pour le césium, est de 4.10^5 Bq/an.

Enfin, les meilleurs comestibles de la région (*Morchella conica*, *Agaricus campestris*, *Boletus edulis*, *Calocybe gambosa*) n'étaient pas contaminées par des éléments radioactifs en 1988 et 1989. Il en est de même pour le champignon de Paris (*Agaricus hortensis*), espèce cultivée.

CONCLUSION

Cette analyse donne un aperçu de la radiocontamination des champignons dans l'est de la France en 1988 et 1989, suite à l'accident de Tchernobyl. Les teneurs en radioisotopes varient en fonction des espèces, des sites de récolte et du temps. Nous envisageons de poursuivre cette étude dans le but d'examiner un plus grand nombre d'espèces et de suivre l'évolution dans le temps des teneurs en radionucléides.

BIBLIOGRAPHIE

- 1 . ELSTNER E.F., FINK R., HÖLL W., LENGFELDER E., ZIEGLER H.
Radioactivity in mushroom, mosses and soil samples of defined biotops in sud Bavaria. Two years after "chernobyl",
Oecologia 1989, 80 : 173-177.
- 2 . FOURRE G.
La radioactivité dans les champignons.
Bull. Soc. Bot. Centre ouest 1988, 19 : 283-304.
- 3 . GUILLITTE O., GASIA M.C., LABINON J.
La radiocontamination des champignons sauvages en Belgique et au Grand Duché du Luxembourg après l'accident nucléaire de Tchernobyl.,
Mem. Soc. Roy Bot. Belg. 1987, 9 : 79-93.
- 4 . MEIJER R.J. de, ALDENHARF F.J., SANSEN A.E.
Resorption of cesium radionucléides by various fungi.
Oecologia 1988, 77 : 268-272.

THE SHORT LIFE RADIONUCLIDES IN MEAT AFTER THE NUCLEAR ACCIDENT IN CHERNOBYL

Smelcerovic M., Popovic D.* and Djuric G.*

Institute for Nuclear Sciences, Vinca and * Department of Physics and Department of Radiology, Faculty of Veterinary Medicine, Beograd, Yugoslavia

ABSTRACT

The paper presents the results of identification and short life radionuclides (I-131, Te(I)-132, Cs-136, Ce-141, 144, Ru-103, 106, Ba(La)-140, Zr-95, Nb-95, Mo-99, Sb-125) mass activities evaluation in meat (lamb, rabbit, game) after the nuclear accident in Chernobyl in 1986.

INTRODUCTION

Immediately after the nuclear accident in Chernobyl in 1986, at the end of April and during May 1986, the magnitude of contamination of the biosphere was mainly determined by short life radionuclides, I-131 above all. Later on, as I-131 decayed, the comparatively short life radionuclides (Sr-89, Zr-95, Nb-95, Ce-141, Ru-103, Ba-140) made an appreciable contribution to the radioactivity on the whole and finally, the main role in the contamination process overtook the long life radionuclides: Sr-90, Cs-134, 137 and partially, Ru-106 (5). But the accident differed from those usually considered in radiological assessments of hypothetical accident releases from nuclear power plants, as the release was prolonged and varied in rate and the composition of the radionuclides mixture was complex (3).

During the accident and afterwards, only I-131, Cs-134 and Cs-137 have been systematically considered, as these are the most important contributors to the total dose. Other radionuclides were only reported in air or deposition although several of them are important short term contributors to external irradiation from deposited material. As for ingestion, some of the short life radionuclides are unjustly neglected considering their amounts found in some foodstuff (2)

In Yugoslavia, the degree of radiocontamination was rather ununiform, mainly due to the uniformity of the rainfalls. However, the overall conclusion was that the sheeps and game were the most endangered again due to the season the accident occurred in (4).

Therefore, the aim of this paper was to identify some of the short life radionuclides in meat immediately after the accident and afterwards. We have also tried to evaluate the contribution of the identified short life radionuclides in the total dose due to ingestion compared to I-131 and the long life Cs-134 and Cs-137.

MATERIALS AND METHOD

Samples of meat (lamb, rabbit, game) were collected by random sampling on highly contaminated area in Serbia and Macedonia, in May and June 1986.

The contents of the radionuclides in the fresh samples of meat was determined on a Ge(Li) detector (ORTEC, relative efficiency 23%) and a 4096 channel analyzer (ND-100). The geometric efficiency for a 200 g PVC cylinder was determined by a secondary standard for solid state matrices (1). The counting time interval was 4.000 - 40.000 s depending of the total activity of the sample. The total error of the method was less than 20%.

RESULTS AND DISCUSSION

Mass activities of the identified short life radionuclides in meat, together with those referring to isotopes of cesium, are presented in Tables 1, 2, 3 and 4. The presented values are given within the estimated ranges of activity. Mark < indicates that the radionuclide was identified only in some of the investigated samples, whereas the activities smaller than 0.100 Bq/kg were indicated as "traces".

Table 1. Short life radionuclides in lamb

Radionuclide	A c t i v i t y (Bq/kg)	
	May-June 1986	April 1987
I-131	43 - 4400	-
Cs-134	678 - 1519	17 - 64
Cs-137	908 - 3300	53 - 187
Ru-103	4 - 29	< 7
Ru-106	12 - 24	< 36
Cs-136	16 - 155	-
I(Te)-132	3 - 21	-
Sb-125	< 75	< 7
Ba(La)-140	23 - 170	11 - 76
Rh-102m	-	20 - 120
Zr-95	< 19	< 2
Ce-141	< 25	< 16
Ce-144	< 110	-
Ag-110m*	-	< 5

Table 2. Short life radionuclides in rabbit and game

Radionuclide	R a b b i t			Venison July 86
	May-June 86	December 86	1987	
I-131	22 - 11	-	-	traces
Cs-134	3 - 146	6 - 86	29 - 98	< 106
Cs-137	6 - 330	17 - 226	38 - 284	< 219
Ru-103	1 - 5	-	-	< 1.2
Ru-106	7 - 90	10 - 23	23 - 151	< 21
Cs-136	0.5- 15	0.2- 6.8	-	< 3.6
I(Te)-132	< 2	-	-	traces
Ba(La)-140	traces	-	-	< 0.4
Rh-120	< 1.4	-	-	-
Ce-141	traces	-	-	traces
Ce-141	traces	-	-	traces
Ag-110m*	-	traces	< 0.13	-

Table 3. Short life radionuclides in lamb and game giblets, June 1986

Radionuclides	lamb liver	lamb fat	game intestines
I-131	260 - 1037	< 54	< 30
Cs-134	473 - 1140	< 6	< 25
Cs-137	1036 - 2490	< 12	< 47
Ru-103	10 - 30	< 4	< 4
Ru-106	traces	< 15	< 15
Cs-136	32 - 112	< 3	< 4
I(Te)-132	< 100	-	-
Sb-125	traces	< 28	traces
Ba(La)-140	22 - 99	-	traces
Rh-102	< 23	< 3	traces
Zr-95	8 - 23	-	-
Mo-99	< 38	-	-
Ce-141	traces	-	traces
Ce-144	traces	-	traces

Table 4. Short life radionuclides in beef giblets, June 1986

Radionuclides	beef liver	beef heart	intestines
I-131	< 21	< 34	3 - 8
Cs-134	< 40	< 12	3 - 10
Cs-137	< 90	< 100	7 - 16
Ru-103	-	-	< 0.9
Ru-106	< 14	< 22	-
Cs-136	< 4	-	< 0.8
Sb-125	< 7	< 3	traces
Ba(La)-140	traces	-	traces
Rh-102	-	traces	traces
Zr-95	-	-	< 0.5
Ce-141	-	-	< 0.5
Ce-144	-	-	traces

All of the short life radionuclides were identified on more than one energy line. Note that some of them (Ru-106, Sb-125, Ce-141,144, Rh-102) could be detected only after the decay of the interfering gamma lines, that is in the samples collected later on. As for radionuclide Ag-110m it is supposed to originate from the material used to bury the reactor.

The results presented in Tab. 1-4 give a preliminary estimation of the contribution of the short life radionuclides in the the total activity of meat immediately after the accident. For more accurate estimation many other parameters should be considered. Nevertheless, the results indicate that the short life radionuclides should not be neglected in the estimation of the total dose due to ingestion immediately after nuclear accidents similar to one in Chernobyl.

CONCLUSIONS

Immediately after the nuclear accident in Chernobyl, in 1986, some of the short life radionuclides, besides I-131 (Te(I)-132, Cs-136, Ba(La)-140, Ce-141,144, Zr-95 ecc) deposited in air and on the ground, reached the meat and game in unneglectable amounts. This was especially significant for lamb and lamb giblets, as the production of lamb happened to be more that 40% of the total meat production in Serbia and Macedonia. Therefore, in the estimation of the total dose due to ingestion in the first month after the accident and immediately afterwards, one should also consider the contribution of the short life radionuclides.

REFERENCES

1. Djuric G., Popovic D. and Adzic P., 1986, Efficiencies of Ge(Li) detectors for different geometries and radionuclides carriers, Proceed.XIIth JUKEM, Beograd, pp.535-542.
2. Djuric G., Popovic D., Smelcerovic M., Petrovic B. and Djujic I., 1989, Radioactive contamination of food and fodder in Serbia after Chernobyl, Radiation Protection- Selected Topics, IBK Vinca, Beograd, pp. 421-426.
3. Summary Report on the Post-Accident Review Meeting on Chernobyl Accident, 1986, IAEA, Safety Ser.75-INSAG-1 Vienna.
4. Popovic D., Djuric G., Smelcerovic M. and Maksimovic B., 1989, Contribution of the short lived radionuclides in milk to the total radiation burden of man after Chernobyl Rad.Prot.-Select.Topics, IBK Vinca, Beograd, pp. 416-420.
5. UN Sci.Committee on the Effects of Atomic Radiation, 1988, Exposures from Chernobyl Accident, UNCEAR, Vienna.

Environmental Radionuclide Migration in the Biwa-lake in the Central Part of Japan

Hiroshige MORISHIMA, Taeko KOGA, Takeo NIWA, Hiroshi KAWAI,
Sohei KONDO and Yasushi NISHIWAKI*
Atomic Energy Research Institute of Kinki University, 3-4-1 Kowakae,
Higashi-Osaka City, Osaka 577, Japan.

* Prof. Y. Nishiwaki is at present associated with the University
of Vienna, Institute for Medical Physics, Vienna, Austria.

I. Introduction

On 26 April 1986 an accident occurred in the No.4 unit of the Chernobyl nuclear station in Ukraina, USSR, which led to a global dispersion of radioactivity. Since then numerous reports on the radioactive fallout due to this accident have been reported in different countries¹⁻⁷⁾.

We prepared the environmental samples collected from Biwa-lake which is the largest lake in Japan and is located in the center of Japan. Radioactivities of the samples were measured over a three-year period in order to estimate the radioactive contamination in Japan.

II. Method

Collection of the Biwa-lake biosphere samples was done every half year for 3 years after 28 May 1986, one month after the Chernobyl accident.

2.1 One cubic meter of lake water was collected at a point one meter deep. The water was evaporated to dryness at 70°C under reduced pressure using a rotary evaporator. The residue was submitted for radio-assay.

2.2 Mud was collected up to 50 ~ 80 cm in-depth from the bottom surface at a point 2 meters deep. The collected mud was fractionized to 2 ~ 5 cm along the depth and sieved with a 16-mesh sieve after dryness.

2.3 Several kilograms of black basses, bluegills, roaches, carps, shell-fishes and water-weeds were collected. The fishes were separated into flesh, internal organs and bones. The shell-fishes were divided into shells and flesh. These parts and the stalks and leaves of the water-weeds were burnt to ashes at 500°C.

2.4 The radio-analyses of all the samples were done using a low-background Ge-γ-ray spectrum analyzer made by NAIG.

III. Results and Discussion

The variation in the radioactivity concentrations of the samples is shown in the figure 1.

3.1 The radio-nuclides in the water residue collected one month after the accident were I-131, Ru-103, Ru-106, Cs-134 and Cs-137. However, after half a year only Cs-137 was detected. The concentration had been reduced to less than one-tenth of the initial value. Three years after the accident the level was 0.12 mBq/l, which was the pre-accident value.

3.2 Radio-nuclides detected in the bottom mud were Cs-137 and natural radioactive nuclides, i.e. K-40, thorium decay products (Th-232, Ac-228) and uranium decay products (Pb-214, Bi-214). Cs-137 depth distribution in the bottom mud showed a maximum at 10 ~ 20 cm under the bottom surface, especially high in the clay-rich mud. This nuclide, however, is estimated to be mainly due to the fallout before the Chernobyl accident, because Cs-134 was hardly detected in the mud, since the cesium isotopic ratio, Cs-134/Cs-137, originating from the Chernobyl accident was 1/2.

3.3 In the organisms living in the lake Cs-134, Cs-137, Zr-95 and a trace of Ag-110m were detected. Among all the samples Cs-137 in the flesh of black basses showed the highest value, 2.0 Bq/kg. Existence of Cs-134 shows that a part of the cesium originated from the Chernobyl accident.

3.4 The concentrations of Cs-137 in the flesh of black basses and carps were 2.0 Bq/kg a half year after the accident. It decreased to 1.45 Bq/kg after one year, 1.1 Bq/kg after 2 years (June 1988), and 0.53 Bq/kg 2.5 years after the accident.

3.5 Variation of cesium in the biosphere organisms is shown in figure 2. The concentration of black basses, bluegills and water-weed was high, on the other hand that of the flesh of shell-fishes was considerably lower. The latter was detected until one year after the accident, however, thereafter under detection limit. Cs-134 concentration of the flesh of the above organisms except water-weed was detected up to 2 years after the accident. That of water-weed was scarcely detected in the whole period. The apparent effective life of Cs-137 in the flesh of black basses was estimated to be about one year, although the radioactivity of Cs-137 was not measured for the identical fish.

IV. Conclusion

Defining the cesium concentration factor as the ratio of the concentration of the organism to the one of the water, the concentration factor of black basses, roaches and bluegills were 1000 ~ 4300. Those of carps and shell fishes were 200 ~ 1000 and 100 ~ 170, respectively. Black basses, etc. are the most appropriate fishes as index organisms for monitoring the dispersion of fission products released from nuclear plants, since the cesium concentration factor of black basses is one order higher than that of other aquatic organisms.

REFERENCES

- 1) World Health Organization: Updated Background Information on the Nuclear Reactor Accident in Chernobyl, USSR, Updated Summary of Data Situation with Regard to Activity Measurement, 5 June 1986.
- 2) F.A.Fry, R.H.Clarke and M.C.O'Riordan: *Nature*, 321, 193p, 15 May (1986).
- 3) L.Devell, H.Tovedal, U.Bergstrom, A.Appelgren, J.Chyssler and L.Andersson? *Nature*, 321, 192p, 15 May (1986).
- 4) G.E.Chabot et.al.: *Health Physics*, 21, 471 (1971).
- 5) M.Aoyama, K.Hirose, Y.Suzuki, H.Inoue and Y.Sugimura: *Nature* 321, 819 ~ 820 (1986).
- 6) T.Birf, J.Feher, L.B.Sztanyik: Radiation Consequences in Hungary of the Chernobyl Accident, Hungarian Atomic Energy Commision, July 1986.
- 7) M.Shimizu: *Radioisotopes*, 22(11), 662 ~ 673 (1973).

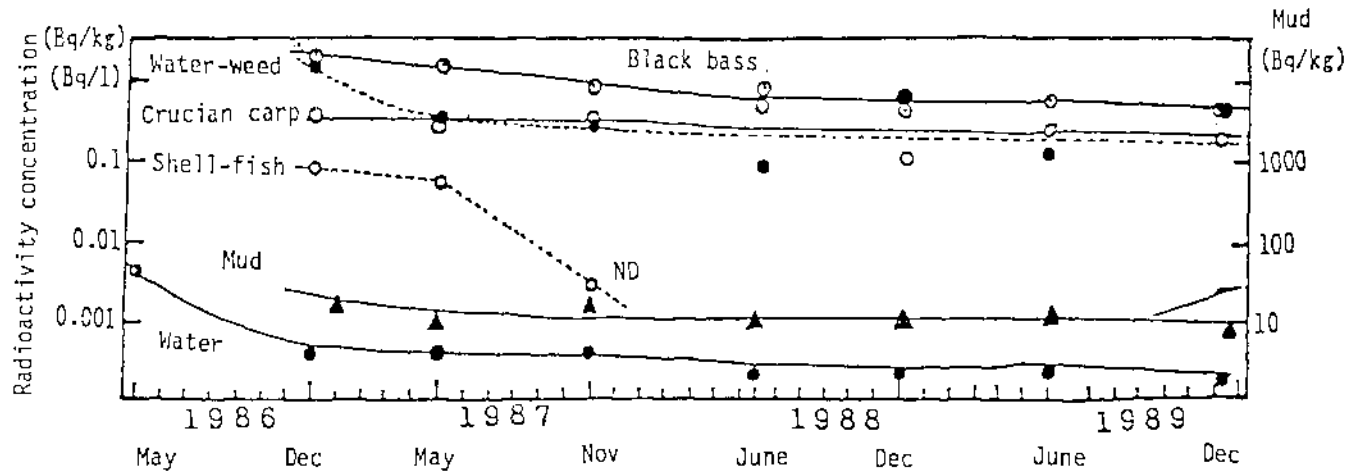

Fig.1 Variation of Cs-137 in the biosphere of Biwa-lake

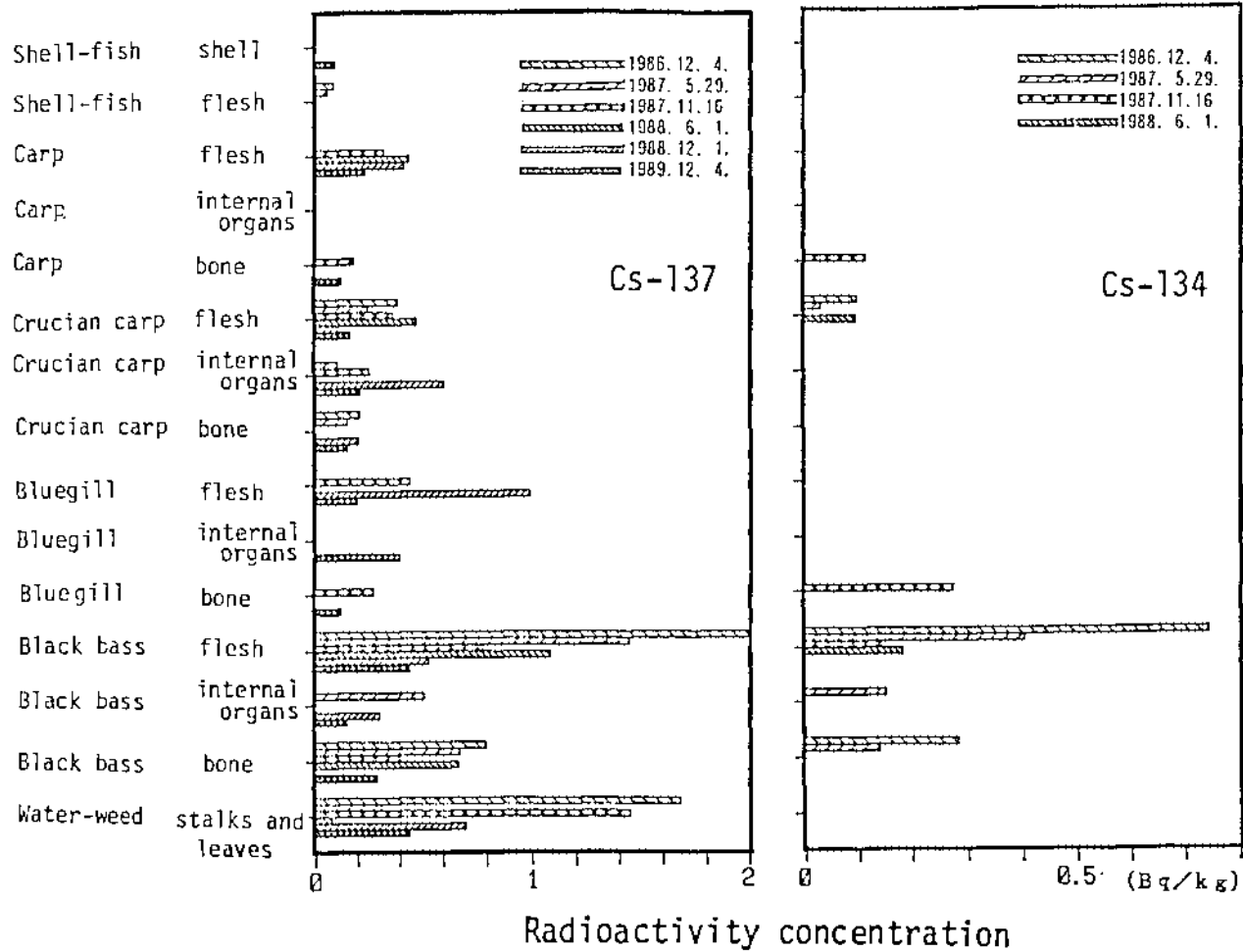

Fig.2 Variation of radioactive cesium in several aquatic organisms

AIR TO MILK TRANSFER OF CESIUM-137

C.Papastefanou

Nuclear Physics Department
Aristotle University of Thessaloniki
Thessaloniki 54006 Greece

ABSTRACT

Cesium-137 data in air, grass and cow's milk are presented over a 4-y period (July 1987 - September 1991). The Cs-137 transfer rates in cow's milk and grass, C_m/C_a ranged between 0.032 and 1.82 kg/l, while the transfer rates in cow's milk and air, C_m/C_a ranged between 4470 and 163350 m³/l. Both the Cs-137 transfer rates were decreased with time passing depending on the Cs-137 concentration of cow's milk, C_m which was decreased with time passing.

INTRODUCTION

Milk is one of the sources for ingestion of Cs-137 in the air-grass-cow-milk-man pathway¹⁻³ and is considered to be a major pathway of exposure to fallout radioactivity⁴. The Cs-137 content of cow's milk was examined over a 4-y period after the reactor accident at Chernobyl (26 April 1986) starting from July 1987. This paper reports data obtained on the basis of continuous monitoring, in order to study transfer phenomena of Cs-137 from air to cow's milk, via the air-grass-cow-milk pathway and explore the possible relation between the Cs-137 concentrations of milk, grass and air. The Chernobyl accident provided a unique opportunity for a such study because of large releases of reactor-generated radionuclides, transport over long distances and dry and particularly wet deposition on pasture or root uptake.

EXPERIMENTAL METHODS

Cow's milk samples (1 kg each) from local dairies were collected at the beginning of each month from two different regional milk plants AGNO Milk Industry and MEVGAL Macedonian Milk Industry, in the Thessaloniki area, in Northern Greece (40° 38'N, 22° 58'E). In parallel, air sampling was carried out using Staplex high-volume air samplers, model TFIA-2 with Staplex type TFAGF 810 Glass Fiber filters 20.3x25.4 cm² (8"x 10") with an average flow rate of 1.84 m³/min (65 ft³/min), in order to determine the Cs-137 concentration of air. Grass samples were cut from an area of ~3 m² (0.125 kg grass per m²) for each sample.

The Cs-137 content of milk, grass and air samples was counted using a high-efficiency (42%), high-resolution (1.9 keV at 1.33 MeV), low-background Ge spectrometer in a standard geometry (6 cm diameter plastic can for air samples and 1-L Marinelli beaker for milk and grass samples. The gamma spectroscopic system was calibrated using NPL (National Physical Laboratory, UK) standard reference sources in both cases, the overall efficiency being known to accuracies of better than 5% for the filter (plastic can) geometry and about 12% for the Marinelli beaker.

RESULTS AND DISCUSSION

Cesium-137 data were obtained for air, grass and cow's milk for the AGNO and MEVGAL regional milk plants over a 4-y period after the Chernobyl accident (26 April 1986) starting from July 1987. A summary of annual data of Cs-137 for the period 1987-1991 is presented in Table 1. Unusual high Cs-137 level₃ in air was measured in July 1987 (0.166 mBq/m³), August 1990 (0.250 mBq/m³) and June 1991 (0.154 mBq/m³), in grass (June 1990: 77.73 Bq/kg) and in cow's milk (July 1987: 33.49 and 39.96 Bq/l for the AGNO and MEVGAL milk plants, respectively). The ratio of Cs-137 to Cs-134 in air, grass and milk samples was as expected because of decay reasons. Although the Cs-137 concentration in air and grass had not significantly been changed on annual basis, whereas the Cs-137 concentration in cow's milk was decreased with time passing, indicating that the Cs-137 concentration in cow's milk depends not only on the grass but other contaminated food for which Cs-137 concentration was decreased with time.

Table 1. Summary of Cs-137 concentrations in air, grass and cow's milk

Year	Air $\times 10^{-5}$ Bq/m ³		Grass Bq/kg		AGNO milk Bq/l		MEVGAL milk Bq/l	
	min	av.	min	av.	min	av.	min	av.
1987	6.29-16.61	9.13	2.67-19.28	6.83	4.2-33.49	10.76	6.5-39.96	14.19
1988	3.03-7.50	5.09	1.96-20.60	7.17	1.96-10.20	4.90	1.84-16.40	6.09
1989	1.50-5.35	2.98	2.48-23.30	7.91	0.27-4.91	1.96	0.44-4.72	2.29
1990	1.23-25.00	4.59	1.12-77.73	10.71	0.15-0.73	0.41	0.27-2.19	0.79
1991	1.07-15.00	3.53	1.14-25.20	6.45	0.13-0.32	0.23	0.14-0.93	0.44

Cesium-137 transfer rates, C_m/C_g (kg/l) and C_m/C_a (m³/l), where C_m is the average concentration of Cs-137 in cow's milk (Bq/l), C_g is the average concentration of Cs-137 in grass (Bq/kg) and C_a is the average concentration of Cs-137 in air (Bq/m³) were determined based on the data corresponding to the period of April-September each year as the cows were mainly fed on grass that period. A summary of the data is presented in Table 2.

Table 2. Cesium-137 transfer rates in cow's milk

Period	C_g $\times 10^{-5}$		C_m		C_m/C_g		C_m/C_a	
	AGNO	MEVGAL	AGNO	MEVGAL	AGNO	MEVGAL	AGNO	MEVGAL
Jul-Sep 87	11.52	10.36	14.57	18.82	1.41	1.82	126504	163339
Apr-Sep 88	5.57	4.85	5.25	6.21	1.08	1.28	94196	111521
Apr-Sep 89	2.45	4.77	2.01	2.57	0.42	0.54	82053	104906
Apr-Sep 90	6.69	15.20	0.49	0.98	0.032	0.064	7283	14646
Apr-Sep 91	4.85	4.19	0.22	0.44	0.052	0.106	4466	9163
Average					0.60	0.76	62900	80715

The ratio C_m/C_a ranged between 0.032 and 1.41 kg/l for the milk of AGNO milk Industry and between 0.064 and 1.82 kg/l for the milk of MEVGAL milk Industry. The lowest values are pretty close to those referred in the literature⁴, e.g. 0.022 or 0.023 kg/l for grass.

The ratio C_m/C_a ranged between 4470 and 126500 m³/l for the milk of AGNO and between 9180 and 163350 m³/l for the milk of MEVGAL. The data of Table 2 shows that the Cs-137 transfer rates, C_m/C_a for both milk plants were decreased with time passing depending on the Cs-137 concentration of milk, C_a which was decreased with time. Very low values of C_m/C_a as low as 71 and 200 m³/l have been reported in the literature⁴.

Papastefanou et al. (1991)⁵ reported that there is a dependency of Cs-137 in milk with air concentration of Cs-137 (high correlation coefficients $r=0.74$ for the AGNO milk and $r=0.84$ for the MEVGAL milk).

REFERENCES

1. Wilson, D.W., Ward, G.M. and Johnson, J.E., 1969, A quantitative model of the transport of Cs-137 from fallout to milk. In: Environmental contamination by radioactive materials, IAEA STI/PUB/226, 736p.
2. Albini, E., Mascaro, I. and Belletti, S., 1990, Measurements of radio-caesium transfer to milk and calculations of resulting dose in Brescia, Italy, following the Chernobyl accident, Health Physics, 59, pp. 455-460.
3. Ward, G.M. and Whicker, F.W., 1990, Milk distribution and feeding practice data for the pathway model, Health Physics, 59, pp. 637-643.
4. Tracy, B.L., Walker, W.B. and McGregor, R.C., 1989, Transfer to milk of I-131 and Cs-137 released during the Chernobyl accident, Health Physics, 56, pp. 239-243.
5. Papastefanou, C., Manolopoulou, M., Stoulos, S. and Ioannidou, A., 1991, Seasonal variations of Cs-137 content of milk after the Chernobyl accident, Health Physics, 61, pp. 889-891.

A plot illustrating the Cs-137 concentrations in milk and grass is shown in Fig.1. C_m is the Cs-137 concentration in milk, in Bq/l, C_g is the Cs-137 concentration in grass, in Bq/kg. a. AGNO Milk Industry, b. MEVGAL Macedonian Milk Industry.

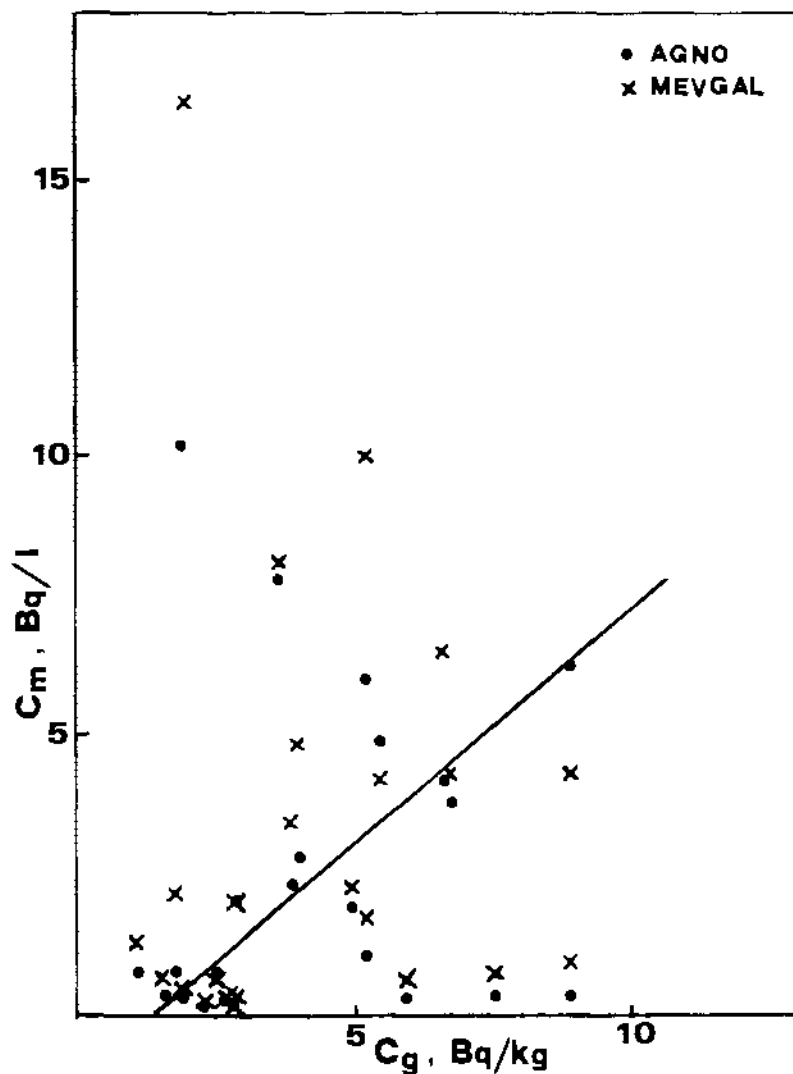

Fig.1. Cesium-137 concentrations in milk and grass for the period April-September each year from 1987 to 1991.

The Spanish Environmental Surveillance Radiological Network
(REVIRA)

J.L. Butragueño; J.P. García; E. Gil and M.J. Granada

Nuclear Safety Council
Justo Dorado 11
28040 Madrid
SPAIN

ABSTRACT

The Spanish Environmental Surveillance Radiological Network (REVIRA) has about 25 automatic stations and several associated laboratories (normally university labs) distributed over the state. The automatic network has been designed to measure dose rate and alpha, beta, radon and iodine air concentration. The measurement equipments consist of a ZnS(Ag) plastic scintillator, a NaI(Tl) crystal detector and a GM detector.

The automatic stations are connected with a Control Center sited in the Nuclear Safety Council headquarter in Madrid. The connection uses the National Telephonic Network and the central software is able to call from the Control Center to each local station, call from the stations if a setpoint is reached and call from the Control Center to set up the microprocesor governing the local stations.

INTRODUCTION

At first, the REVIRA project was an I+D General Program of the Nuclear Safety Council (CSN), but after Chernobyl's accident became a priority objective of CSN. The national surveillance radiological network has been designed to meet the following objectives:

- To know the radionuclide distribution and evolution in environment and the environmental radiation levels.
- To have experimental data for estimating the potential radiological risk to population due to a radioactive contamination, and to help the decision making process.
- To make periodic reports with these data.

REVIRA STRUCTURE

The REVIRA has two different stations:

- Automatic stations to measure air activity concentration and the dose rate.
- Stations in which a sample is taken and an analysis program is followed.

SAMPLE AND ANALYSIS STATIONS NETWORK

This network is constituted by a set of both, national research and university laboratories in all the national territory. These stations sample periodically: air, rain water and soils. The radioactivity contents is then analyzed in a lab. (total alpha and beta activity concentration and dose rate). A special interest is taken in iodine and strontium activity concentrations and the dose rate levels are measured with TLDs.

There are also taken samples of superficial water (continental and marine) foods (milk, vegetables, meat and fish) and its analysis are made.

AUTOMATIC STATIONS

The automatic stations measure the following variables in continuous form:

- Air activity concentration of total alpha aerosols.
- Air activity concentration of total beta aerosols.
- Air activity concentration of radioiodines.
- Air activity concentration of Radon.
- Dose rate.

The equipments have a particle aspiration and retention systems. The aspiration system has a constant flow pump of 0.0017 m³/s. The retention system has filters for aerosols and for radioiodines. This system is constituted by the following devices:

- PLASTIC SCINTILLATOR DETECTOR
 - . Efficiencies

Cl-36	28% - 35%
Am-241	17% - 22%
 - . Alpha Background 0.01 cps
 - . Beta Background 0.40 cps
 - . L.I.D. =< 0.5 Bq/m³
- CRISTAL DETECTOR
 - . Efficiencies

Ba-133	>= 5%
--------	-------
 - . Minimal concentration detectable for I-131 (sample time 3600 sec) =< 0.5 Bq/m³
- GEIGER-MÜLLER DETECTOR

	LOW DOSIS	HIGH DOSIS
Background (cps)	0.183	0.033
Energy response (Mev)	(0.05 - 1.5)	(0.05 - 1.5)
Accuracy Cs-137	± 20%	± 20%
Measure range (Gy/s)	8.3 10 ⁻¹³ -5.5 10 ⁻⁷	5.5 10 ⁻¹¹ -8.3 10 ⁻⁴

A graphic representation of the automatic network is presented in the following figure.

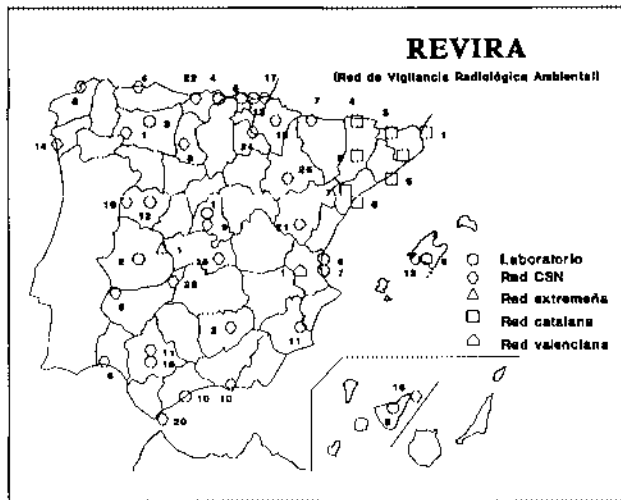

These stations are located in the same places that some National Weather Institute automatic stations. So, the meteorological parameters (air temperature, relative humidity, wind direction and speed, rain intensity and air pressure) are also received.

TRANSMISSION DATA

The radiological and meteorological data, collected in the automatic stations, are transferred by the national telephonic network. A hardware device called DSIC (Selective and Intelligent Discriminator of Calls) is located in each station and stores each 10 min the radiological and meteorological parameters (having a maximum storage capability of 48 hours). The DSIC has an internal Modem connected to a telephone number and is called automatically from Control Center.

THE CONTROL CENTER

The Control Center sited in the Nuclear Safety Council headquarter in Madrid, has three personal computer (Mod. 80386). These PCs are linked by a Local Area Network. Two of these three PCs takes charge of the communication with the DSIC, and the other one makes the management of the data collected from the others PCs.

The PCs main functions are :

- To set alarms detections if a set point is reached for a parameters.

- To call manual and automatic to all the remote automatic stations (radiological and/or meteorological parameters).
- To request the parameters state from the radiological equipment (configuration of parameters, calibration factors, backgrounds, set points, etc)
- To display graphics and prints of time and spatial evolutions for all the parameters of automatics stations (daily and monthly evolutions, low and high value for each day and station, spatial values in all the National Territory, etc.).

Progress on the IAEA/GEC Programme on Validation of
Environmental Model Predictions (VAMP)

G.S. Linsley, S. Hossain, M.J. Crick, K-L. Sjoebloom
International Atomic Energy Agency, Vienna, Austria
and

G.N. Kelly

Commission of the European Communities, Brussels, Belgium

This programme seeks to take advantage of the unique opportunity created by the Chernobyl Accident for testing and improving models used for radiological assessment and involves laboratories in more than 20 countries.

Data acquired from the extensive post-Chernobyl measurement programmes in Europe and the former Soviet Union have been used as a basis for reviewing our understanding of important transfer processes and for developing model test scenarios. This paper describes the progress of VAMP since its inception in 1988 and the work and achievements of its four working groups: Terrestrial, Urban, Aquatic and Multiple Pathways.

USE OF MICRONUCLEI IN BIOLOGICAL DOSIMETRY WITH GAMMA
RAYS: A METHOD FOR RAPID SCREENING IN THE CASE OF
LARGE-SCALE RADIATION ACCIDENTS

DI GIORGIO, M.; FERRARO, M.; THOMASZ, E.

Comisión Nacional de Energía Atómica
Gerencia Seguridad Radiológica y Nuclear
(1429) Av. del Libertador 8250
Buenos Aires - Argentina

The dose-effect relationship of micronuclei frequencies in cytokinesis-blocked human lymphocytes after in vitro gamma irradiation of whole blood in the range from 0,5 to 4 Gy was studied. A linear-quadratic response was obtained. Due to the high background micronuclei frequency and their large interindividual variability observed ($0,013 \pm 0,008$) the micronucleus assay may be potentially useful to estimate gamma radiation doses above 0,5 Gy.

INTRODUCTION

For nearly 30 years the frequency of chromosomal aberrations (particularly dicentric) observed in cultured peripheral blood lymphocytes has been used as a biological dosimeter for assessing accidental overexposures to ionizing radiation.

In recent years there have been some serious accidents, such as Chernobyl and Goiânia, that have involved large numbers of people. The time needed for scoring a sufficient number of metaphasic cells for dose estimation, specially in the case of large-scale accidents as well as the need for properly trained and experienced personnel, justified the search for other methods. The micronuclei assay provides an easier and faster method for quantifying chromosomal damage.

Several laboratories studied the dose-effect relationship for micronuclei frequencies X-ray-induced but there is scarce information for γ -ray-induced micronuclei.

Taking into account all the above mentioned facts, we have performed a dose-response relationship using γ -rays from a Co-60 source.

MATERIALS AND METHODS

Radiation exposure protocol: Heparinized venous whole blood samples were collected from two healthy adults aged below 35 years old to perform the dose-response relationship. Samples were exposed at 37 °C to 0,5- 1- 2 and 4 Gy of Co-60 gamma radiation, delivered at a mean rate of 0,70 Gy/min (Picker C4M60 machine) in our Secondary Standard Dosimetry Laboratory. An extra blood sample of a single donor was irradiated with 3 Gy in the same conditions. The micronuclei base-line was estimated from blood samples of ten healthy donors.

Culture methodology : Whole blood samples were incubated in medium RPMI 1640 complemented with 15 % fetal calf serum at 37 °C for 72 hs. Stimulation of lymphocytes was reached by addition of phytohemagglutinin P at a final concentration of 1 µg/ml. At 44 th hour of incubation, cytochalasin B at a final concentration of 4,5 µg/ml was added to the cultures. Cells were spread onto slides after a mild hipotonic treatment (1) and fixed in acetic acid-methanol 1:3 mixture. Cells were stained by Giemsa 10 % .

We established the micronuclei frequencies scoring 500-2000 binucleate cells per dose and per blood sample. The criteria of Countryman and Heddle (2) were applied to identify micronuclei in binucleated cells.

Curve fitting and data handling : A weighted least squares method was used for curve fitting, using as a weight the value of the observed frequency of micronuclei for each observation. The distribution of micronuclei in binucleate cells for each value of studied dose were compared with Poisson distribution using the u test (3), χ^2 test and the variance to mean ratio.

RESULTS

Table 1 shows the spontaneous frequency of micronuclei and the distribution in unirradiated cytokinesis-blocked lymphocytes from 10 donors. The mean base-line frequency was $0,013 \pm 0,008$. The great variability between donors have already been described by various laboratories (4, 5, 6)

The dose response data obtained by scoring cytokinesis-blocked cells from 2 donors as well as the distribution of micronuclei in binucleate cells are given in table II.

The parameters of the yield equation were obtained by fitting data of individual donors separately. The best fit in the range of 0-4 Gy was linear-quadratic and the relationship is :

$$Y = c + \alpha D + \beta D^2 \quad D = \gamma\text{-ray dose in Gy}$$

$c = 7,44 \text{ E-}03 \pm 2,25 \text{ E-}03$	$\alpha_1 = 2,15 \text{ E-}02 \pm 3,7 \text{ E-}03$
$\beta = 3,17 \text{ E-}02 \pm 1,12 \text{ E-}03$	$\chi^2 = 5,36 \text{ E-}02$

Records were kept of the proportions of binucleate cells having 0, 1, 2 or 3 or more micronuclei in preparations from donors 1 and 2. Table III

The distribution of micronuclei were overdispersed relative to that expected based on Poisson assumptions, except for 1 Gy. So we can not find a clear dose-distribution relationship.

The yield of micronuclei in a 3 Gy irradiated blood sample of a single donor was $0,31 \pm 0,025$. This value is quite similar to that obtained using our curve coefficients ($0,35 \pm 0,03$).

DISCUSSION

The high background micronuclei frequencies and their large interindividual variability could impose some uncertainties on using micronucleus assay for estimating individual low dose whole body exposures in vivo. Thus micronucleus analysis may be potentially useful to estimate X-ray doses above 0,1 Gy (5, 7) and γ -ray doses above 0,5 Gy, according to our data. We have not observed saturation of the dosimeter after exposure to 4 Gy

Our data show a very good fit to the linear-quadratic model with a χ^2 of 5,36 E-02 with 15 df. In order to check our curve fitting we have compared a 3 Gy irradiated blood sample of a single donor (0,31 \pm 0,025) with the curve value at the same dose (0,35 \pm 0,03) being quite similar. These values are in good agreement with the value reported by Huber et al (8) at the same dose with Cs-137 (0,345 \pm 0,027).

Distribution of micronuclei among cells were found to be overdispersed for 0,5- 2 and 4 Gy relative to that expected by Poisson statistics. Thus we have not found a clear dose-distribution relationship in contrast with the data reported by Prosser et al (7) where the distribution of micronuclei was overdispersed and moreover the variance to mean ratio, increased as the dose increased.

According to our results, the micronucleus assay is a suitable dosimeter for estimating in vivo whole body exposures to γ rays for doses above 0,5 Gy, and it is particularly useful for large scale screening programs due to its simplicity and to the short time required for its analysis.

TABLE I

MICRONUCLEI (MN) FREQUENCIES AND DISTRIBUTIONS IN UNIRRADIATED CYTOKINESIS BLOCKED LYMPHOCYTES FROM SEVERAL DONORS

Standard errors based on Poisson distribution.

Donor	Number of Cells	Number of MN	MN/Cell	Number of Cells with MN	MN Distribution/Cell		
					0	1	2
1	500	11	0,022 \pm 0,002	10	490	9	1
2	500	3	0,006 \pm 0,003	3	497	3	-
3	500	7	0,014 \pm 0,005	7	493	7	-
4	500	1	0,002 \pm 0,002	1	499	1	-
5	502	13	0,026 \pm 0,007	13	489	13	-
6	500	10	0,020 \pm 0,006	10	490	10	-
7	500	3	0,006 \pm 0,003	3	497	3	-
8	1000	7	0,007 \pm 0,003	6	994	6	1
9	500	5	0,012 \pm 0,005	5	495	4	1
10	500	6	0,012 \pm 0,005	6	494	6	-

TABLE II
MICRONUCLEI (MN) FREQUENCIES AND DISTRIBUTIONS IN CYTOKINESIS BLOCKED LYMPHOCYTES FROM TWO DONORS
IRRADIATED IN VITRO TO THE GAMMA RAY DOSES INDICATED.

Standard errors based on Poisson distribution.

Dose (Gy)	Number of Cells	Number of MN	MN/Cell	Number of Cells with MN	MN Distribution/Cell				
					0	1	2	3	4
0.5	1021	30	0.029 ± 0.005	27	994	24	3	-	-
0.5	1747	45	0.026 ± 0.003	44	1703	43	1	-	-
1	577	34	0.059 ± 0.010	32	545	30	2	-	-
1	1028	60	0.058 ± 0.007	56	970	56	2	-	-
2	1004	179	0.178 ± 0.013	157	847	136	20	1	-
2	1692	304	0.179 ± 0.010	266	1426	236	24	4	2
4	501	308	0.614 ± 0.035	224	277	153	56	13	-
4	826	487	0.590 ± 0.026	339	487	223	80	20	6

TABLE III
MICRONUCLEI (MN) DISTRIBUTION IN IRRADIATED CYTOKINESIS BLOCKED LYMPHOCYTES TO THE GAMMA RAY DOSES INDICATED

Pooled data from donors 1 and 2.

Dose (Gy)	Number of Cell	Number of MN	MN/Cell	Mn Distribution/Cell					σ^2 v	u	χ^2
				0	1	2	3	4			
0.5	2166	75	0.021 ± 0.003	2697	67	4	-	-	1.06	2.77	9.66 *
1	1605	94	0.580 ± 0.005	1515	86	4	-	-	1.07	0.68	0.81
2	2696	483	0.179 ± 0.008	2273	372	44	5	2	1.11	4.10	46.4 *
4	1327	795	0.589 ± 0.021	764	375	148	33	6	1.11	2.92	15.4 *

* Significantly over dispersed relative to expected Poisson distribution.

REFERENCES

1-Iskander, O. (1979) An Improved Method for the Detection of Micronuclei in Human Lymphocytes, *Stain Technol.* 54, 221.
 2-Countyman, P. and Heddle, J. (1975) The Production of Micronuclei from Chromosome Aberration in Irradiated Cultures of Human Lymphocytes, *Mutat. Res.* 41, 321-332.
 3-Papworth, D. Appendix to Paper by Savage, J.R.K. (1970) Sites of Radiation Induced Chromosome Exchanges, *Curr. Top. Radiat. Res.*, 6, 129-194.
 4-Fenech, M. and Morley, A. (1985) Measurement of Micronuclei in Lymphocytes, *Mutat. Res.*, 147, 29-36.
 5-Huber, R., Streng, S., Bauchinger, M. (1983) The Suitability of the Human Lymphocyte Micronucleus Assay System for Biological Dosimetry, *Mutat. Res.*, 111, 185-193.
 6-Littlefield, L.G., Sayer, A.M., Frome, E.L. (1980) Comparison of Dose-Response Parameters for Radiation-Induced Acentric Fragments and Micronuclei Observed in Cytokinesis-Arrested Lymphocytes, *Mutagenesis*, 4, 269-270.
 7-Prosser, J.S., Moquet, J.E., Lloyd, D.C., Edwards, A.A. (1988) Radiation Induction of Micronuclei in Human Lymphocytes, *Mutat. Res.* 190, 37-45.
 8-Huber, R., Braselmann, H., Bauchinger, M. (1989) Screening for Interindividual Differences in Radiosensitivity by Means of the Micronucleus Assay in Human Lymphocytes, *Radiat. Environ. Biophys.* 20, 113-120.

Fig. 1 Micronuclei frequencies in irradiated blood samples from 2 donors

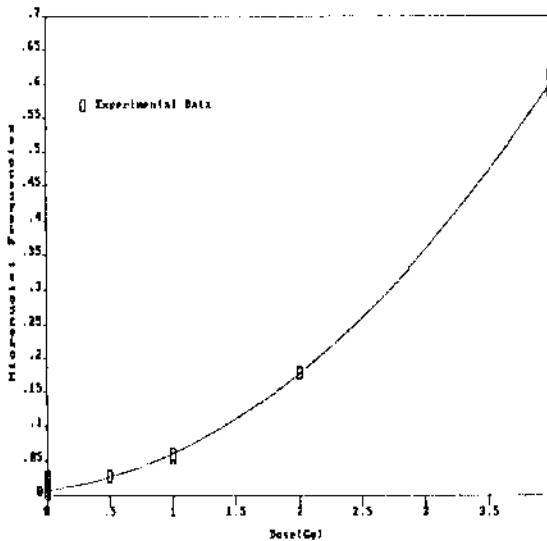

MEDICAL ASPECTS OF RADIATION PROTECTION IN NORMAL AND ACCIDENTAL SITUATION

D.Stojanović

"Boris Kidrič" Institute of Nuclear Sciences, Vinča, Belgrade, Yugoslavia

ABSTRACT

The most important radiation medicine aspects of the diagnostics of the radiation damage, problems of differential diagnosis, having in view the persons in the field of medicine and industry. The effect of decontamination in the prevention of irradiation was evaluated at persons employed on the Reactor RA in Vinča, in laboratories which produce and use radionuclides in period of time over 30 years.

A special interest was given in work to contemplation of some methods of biological indications, as well as to the haematological, biochemical, cytogenetical parameters with estimation of their relevancy for evaluation of the possible postirradiation effects in normal and accidental situation and expert opinion at occupational exposition too.

INTRODUCTION

Investigations are included experimental materials in the frame of decontamination of normal skin contaminated with radioiodine or radiocaesium in experimental conditions from aspects of the influence of some decontamination means on the skin permeability and the degree of internal contamination in dependence of the state of the skin, type and chemical form of radiocontaminant. In experimental conditions the efficiency of decontamination based on evaluation of the total body burden of radionuclides and residual radioactivity in the decontaminated region. In human praxis the decontamination treatment presents the most effective medico-prophylactic procedure in the prevention of local and total irradiation, although base on phenomenal evaluation.

The investigations in experimental conditions concerns also the reactivity of some radiosensitive systems at condition whole body gamma irradiation as well as effects of application of the antiradiation means on the haematopoietic tissue. At small laboratory animals were observed: lethality and surviving, clinical changes, quantitative changes of total leucocytes, erythrocytes

and platelets count, differential blood picture, change in percentual ratio between small and large lymphocytes in peripheral blood, occurrence of cytomorphological changes in white cells of peripheral blood, haemoglobin, haematocrite and other changes.

The effect of the applied drugs on the postirradiational haematologic reaction and reparatories, have been observed in dependence on ordinary time in some phases of acute radiation illness.

In epidemiological study the results of medical supervision of persons occupationally exposed to ionizing radiation, controlled in period of ten years have been presented. Observations were selected according to occupation (workers employed in metal, chemical, paper and tobacco industries and avia companies), to the sex, age, character of exposition (external and internal exposures), and dosimetric data of the received doses.

In the paper the problems of the differential diagnosis of some states and diseases according to the systems (skin, eyes, cardio-vascular system, endocrine and nervous system, haematopoietic tissue), have been discussed with special attention to focuses in the organism, which can change numerical values in the peripheral blood or as far as their look is concerned that could be very similar to changes affected by action on of ionizing radiation.

On the basis of the existed criteria for evaluation of haematological parameters, pathological states of the skin, lenticular injury, changes in cardio-vascular system and changes in other systems too, indications and contra-indications for work with ionizing radiation have been observed. The incidence and persistence of morphological changes of lymphocytes and granulocytes in peripheral blood and anaemic states in correlation with changes, caused other harmful factors arised from working environment.

METHODS

Methodology includes the experimental study and the analysis of epidemiological data taken from the human praxis.

Experimental: The experiments were performed on the white male rats, narcotized with urethane. The skin made "Fat-free" using soap before contamination. The radioactivity of the applied amount of solution $^{131}\text{I}\text{NaI}$ and $^{137}\text{CsCl}$ was 1,85 MBq. Decontamination of the skin: five treatments were performed in duration of the minute each. Means for decontamination, saline, 1% Cetavlon, 2,5% Sterigal, 0,5% iodine tincture, 5% HMF, 0,25% DBS-7R, PAM-03.

Radiation source and exposure conditions: Irradiation was carried out using cobalt-60 gamma-rays at a dose rate of 23,5 Gy/min and at a distance of 70 cm. During irradiation each animal was placed in a separate compartment of the wooden box. The integral dose to the whole body was 6 Gy what represents a sublethal dose under the given experimental conditions. The animals were isolated in a separate cage and kept under the usual conditions of feeding and care until the end of the experiment.

Treatment with Plibex and pyridoxine: Plibex is given every second day in quantity of 0.1 ml per animal beginning first day or tenth day after irradiation. Given content of Plibex^(R) is following: thiamine-chloride 0.2 mg, riboflavin 0.02 mg, nicotinamide 0.5 mg, calcium-pantotenate 0.05 mg, pyridoxine chloride 0.04 mg and cyanocobalamine 0.02 µg. Pyridoxine was applied i. m. every day at a dose of 0.3 mg/animal.

RESULTS AND DISCUSSION

1. Decontamination of persons at an operating nuclear plant and in laboratories of Institute "Boris Kidrič" - Vinča

- Period of observation: over 30 years
 - Number of cases: 76
 - Anatomical locality: fingers of handful, handfuls, forehead, hair forehead, nose, neck, face, lips, temple, ears, foot, fingers of foot, frontal bump, eye, cheek.
 - Radiocontaminants: ^{131}I , ^{198}Au , ^{239}Pu , ^{137}Cs , ^{60}Co , ^{111}Ag , ^3H , ^{24}Na , ^{109}Ag , Unknown composition.
 - State aggregation: dust, gas, liquid.
 - Decontamination: contained 4-5 procedures by use of cotton, wool and rinsing or by cleaning with solution of means for decontamination: 5% detergent, toilet soap, 3% citric acid, saline, 2% boric acid, combination 5% detergent with 2% versen, permanganate.
2. The observed changes, deviations and diseases of the supervised persons in dependance of working exposition is given in Table 1.

Table 1. Number of supervised person

Working exposure (years)	N	Skin	Haematologic changes		Eyes
			Numerical	Morphologic	
1 - 5	50	14	5	5	1
6 - 10	31	5	8	8	1
11 - 15	34	26	19	5	2
16 - 20	16	5	6	3	1
under 20	17	2	4	1	-

3. Haematological effects of whole body irradiation and treatment with pyridoxine

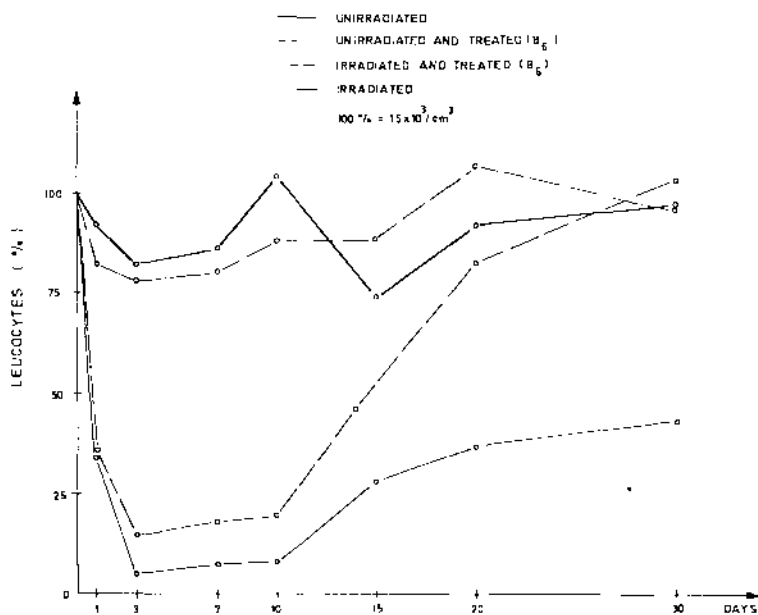

FIG. 1. Leucocytes in the peripheral blood.

REFERENCES

1. Stojanović D., Current Biomedical Problems in Radiation Protection: Advances in Yugoslavia and Italy, pp. 52-58, ENEA, Udine, 1988.
2. Milivojević K., Stojanović D., Human External Decontamination- ours Experimental and Accidental Experiences, XIVth Regional Congress of IRPA, pp. 527-530, Kupari-Dubrovnik, 1987.

CYTOGENETIC MONITORING OF NUCLEAR POWER PLANT WORKERS IN FINLAND

S. Salomaa and A. Koivistoinen

Finnish Centre for Radiation and Nuclear Safety
P.O.Box 268, 00101 Helsinki, Finland.

ABSTRACT

Twenty nuclear power plant (NPP) workers from the two plants in Finland are scored annually for chromosomal aberrations. Results from the first two years of surveillance show that the NPP workers had significantly higher frequencies of radiation-related chromosome-type aberrations in their lymphocytes than the controls. The frequencies of dicentric and ring chromosomes were, however, well within the range that could be expected on the basis of their cumulative radiation exposures. Lymphocyte micronucleus analysis did not reveal any differences between the exposed and the controls.

INTRODUCTION

The frequency of chromosomal aberrations in peripheral blood lymphocytes is a sensitive, dose-dependent indicator of exposure to ionizing radiation. In the present study, we have applied the analyses of chromosomal aberrations and micronuclei in the surveillance of occupational exposure of NPP workers to low-level radiation (mean annual doses of about 5 mSv). As also other factors than the occupational radiation exposure affect the extent of chromosomal damage, the results of the cytogenetic analyses were compared to an unexposed control group of the same size, matched by the known confounding factors (age, sex, smoking habits and medical X-ray examinations).

MATERIAL AND METHODS

Altogether 20 workers from two different plants, a boiling water reactor (BWR) plant and a pressurized water reactor (PWR) plant, were scored annually for chromosomal aberrations. The workers attending the cytogenetic analyses represented the most exposed personnel at their plants, with the highest life-time and/or annual radiation doses. The mean life-time doses were 34 mSv in 1988 and 36 mSv in 1989 for the group working at the BWR plant, and 71 mSv in 1988 and 77 mSv in 1989 for the group working at the PWR plant. The mean employment times were about 10 years in both groups. The results of the cytogenetic analyses were compared to an unexposed control population of the same size, matched by age, sex, smoking habits and X-ray examinations. Domestic radon exposure was also taken into account in part of the material. Indoor radon measurements were carried out during winter with α -film boxes (type SSNTD with Makrofol polycarbonate film).

For the chromosomal aberration analysis, peripheral blood was cultured for 48 hours with Eagle's MEM medium, human AB serum and leukoagglutinin. The control cultures were run parallelly with the exposed group. Five hundred cells from each subject were analysed from Giemsa-stained, coded slides. The

chromosomal aberrations scored included both chromatid aberrations (breaks, gaps) and chromosome-type aberrations (breaks, gaps, dicentrics, rings, translocations and inversions).

Cultures for the micronucleus analysis were established from the same blood samples as the chromosome cultures. Lymphocytes were isolated with Ficoll-Paque, and cultured with RPMI-1640 medium, foetal calf serum and phytohemagglutinin. Cytokinesis of the daughter cells was blocked by cytochalasin-B, which was added at 44 hours, and after 72 hours in culture, the cells were harvested by cytocentrifugation, fixed with methanol and stained by May-Grünwald-Giemsa. From each subject, 3000 binucleated cells were analysed for micronuclei.

The Mann-Whitney U-test and the Fisher's exact probability test were used in the statistical analysis of the cytogenetic data.

RESULTS

The annual data of chromosomal analyses are shown in Table 1. In 1988, the workers of the BWR plant did not differ from the controls, but most of the workers in the PWR plant group had higher frequencies of chromosome-type aberrations than the controls ($P < 0.05$, Mann-Whitney U-test).

Table 1 Frequencies of chromosomal aberrations (per 1000 cells, gaps excluded) among the NPP workers of the BWR and PWR plants and the parallel controls.

Group/year	Number of			Cells with	
	dic, r	cs	ct	cs	ct
BWR/1988	0.8	5.2	4.4	4.2	3.6
Control	1.2	4.6	4.6	4.0	4.0
PWR/1988	1.4	9.0*	9.0	6.2	7.0
Control	0.8	7.0	9.0	4.4	7.0
BWR/1989	1.8*	7.4*	7.4	5.6	6.2
Control	0.4	4.6	8.2	3.8	5.6
PWR/1989	2.3*	6.6*	6.8	5.4	6.0
Control	0.8	4.7	7.3	4.1	6.3
Radon control	0.8	3.8	6.0	3.8	5.2

dic, dicentric chromosomes; r, rings; cs, chromosome-type aberrations; ct, chromatid aberrations; * $P < 0.05$

After the first year, it turned out that the workers of the PWR plant live in houses with high indoor radon concentrations (mean winter concentration, 600 Bq/m³), whereas the radon concentrations in the dwellings of the controls were estimated to be close to the country's average, about 100 Bq/m³. This was also later verified by measurements. Thus, next year, an additional control group was gathered of persons living in the area; the mean radon concentration in their dwellings was 490 Bq/m³. However, the aberration frequencies of the radon controls were

similar to those of the other controls, but the PWR plant workers differed significantly from both of these control groups. Thus, the domestic radon exposure did not explain the increased frequencies of radiation-related aberrations. In the second year, also the workers at the BWR plant had significantly higher frequencies of chromosome-type aberrations. At the individual level, there were no exceptionally high frequencies of dicentric and ring chromosomes, and the biological dose estimates were in the range that could be expected by the cumulative radiation doses.

The combined chromosomal aberration data from the first two years of surveillance are in Table 2, showing significant elevations in radiation-related chromosome-type aberrations among the NPP workers. Moreover, those aberrations are also more frequent among the subjects with higher radiation doses.

Table 2 Frequencies of chromosomal aberrations (per 1000 cells, gaps excluded) among the NPP workers, divided into two subgroups by their life-time doses, and the controls. The statistical analyses have been performed only between all the NPP workers and their matched controls.

	Control	NPP; all	NPP; < 50 mSv	NPP; 50-100 mSv
No. of cultures	40	40	19	21
No. of individuals	23	23	13	11
Total no. of cells	19,932	19,845	9,500	10,345
Mean age (yr)	43.0	42.7	40.9	44.3
Mean dose (mSv)	0	54.7	30.1	76.9
% smokers	58	58		
% with X-ray exam.	43	48		
No. of chromosome ab.	5.3	7.2**	6.4	7.8
No. of dic. and rings	0.8	1.5*	1.4	1.6
No. of fragments	3.5	3.8	3.1	4.5
No. of stable aberr.	0.7	1.3*		
No. of chromatid aberr.	7.3	6.9	5.8	7.9
Cells with chromosome aberr.	4.1	5.3*	4.7	5.9
Cells with chromatid aberr.	5.7	5.7	4.7	6.6

* $P < 0.05$; ** $0.05 < P < 0.001$

Some effect of ionizing radiation could be seen also after medical exposures. Among the controls, those with medical X-ray examinations had significantly more cells carrying translocations and inversions than those with no (major) examinations (1.1×10^{-3} v. 0.3×10^{-3}).

Chemical agents, like compounds in cigarette smoke, mostly cause chromatid aberrations in peripheral lymphocytes. In the present study, the frequencies of chromatid aberrations were higher among the smokers in both the NPP workers (8.5×10^{-3} v. 4.5×10^{-3}) and the controls (8.5×10^{-3} v. 5.5×10^{-3}); the differences were highly significant ($P < 0.01$).

Micronucleus analyses in cytokinesis-blocked lymphocytes did not show any differences between the NPP workers and the controls (Table 3). Neither was there any difference between the smokers and the non-smokers (data not shown).

Table 3 The frequency of micronucleated lymphocytes among the NPP workers and their controls. There were ten subjects in each group.

Group	No. of cells	Cells with MN (per 1000)	Total No. of MN (per 1000)
BWR plant	30,000	8.0	9.7
Control	28,793	9.9	11.6
PWR plant	30,000	10.8	13.2
Control	30,000	10.2	12.3

CONCLUSIONS

Low-level exposure to ionizing radiation was shown to cause a significant increase in the frequency of chromosome-type aberrations in the lymphocytes of nuclear power plant workers. Domestic radon exposure did not explain the elevated frequencies observed at the PWR plant, that is located in a radon-rich area. The effect of medical X-ray examinations was seen as a significant increase in the frequency of stable chromosome aberrations. Smoking caused a highly significant increase in the frequency of chromatid aberrations.

The micronucleus analyses failed to reveal any differences either with respect to radiation exposure or smoking. Thus, at present, it seems to be a less sensitive method than the conventional chromosome aberration analysis in the detection of cytogenetic effects of genotoxic exposures.

CHROMOSOMAL ABERRATIONS IN PERSONS PROFESSIONALLY EXPOSED TO IONIZING RADIATION

G. Joksić and B. Marković

Institute of Occupational and Radiological Health
University Clinical Center of Belgrade, Deligradska 29
11000 Belgrade, Yugoslavia

ABSTRACT

Dicentric aberrations indicate significantly greater incidence (25-28% of cases analysed) in the group dealing with radionuclides when compared to those exposed to sealed sources of radiation (8-12% of cases analysed), with the similar duration of professional exposure. Dicentric frequency in professionals depends on the source of radiation, working conditions and applying of radiological protection measures.

INTRODUCTION

Professional exposure of a great number of working population to various mutagenic agents represents an exceptionally significant field of research. The results of this research have an important practical application in prevention of occupational diseases. For over 20 years the frequency of chromosomal, particularly dicentric, aberrations observed in cultured peripheral blood lymphocytes have been used as a biological dosimeter for assessing accidental overexposure to ionizing radiation (1). In professional exposure, chromosome aberration analysis is most commonly qualitative in character (determines the type and incidence of aberrations), and it is performed in cases when medical parameters or dosimetric data indicate possible irradiation (4).

MATERIAL AND METHODS

The results of several years long study on chromosomal aberrations in persons occupationally exposed to ionizing

radiation are presented in this paper. The professionals are classified in groups according to the type of work and duration of the exposure in the zone of ionizing radiation. For each patient detailed anamnestic professional questionnaire is completed and data on possible therapy with physical and chemical agents as well as on diagnostic procedures with ionizing radiation for the past 12 months are registered. The results of chromosome aberration analysis for the 634 professionals are presented in the following results.

RESULTS AND DISCUSSION

The results, presented in the Table 1., from investigations lasting several years, indicate that the largest percent of subjects with chromosomal aberrations are found in professional groups working with radionuclides, and those are health workers in nuclear medicine, personnel in research laboratories using radionuclides as markers and workers in industries applying tritium. In the group working in nuclear medicine and research laboratories the percent of subjects with dicentrics was 25, while 5.4% was with symmetrical chromatid interchanges or triradials. In the group of workers in tritium applying industries (tritium was in the form of gas), dicentric chromosomes were found in 28.9% of cases, while in the group of workers exposed to tritium in the form of radioactive luminous paint, percent of cases with dicentrics was 8.3%. In the group of radiologists and technicians, 12.2% of cases was found with dicentric aberrations. In the group of professionals working on application of invasive hemodynamic methods in cardiology 8% of cases was found with dicentric aberrations, and in 12% of cases chromatid interchanges and triradials were found. The results indicate significantly greater incidence of chromosomal aberrations in the group dealing with radionuclides when

Chromosomal aberrations in professionals exposed to ionizing radiation

	number of cases analysed	with dicentric	with chromatid interchanges	with other aberrations
*	92	23 (25%)	5 (5.4%)	23 (25%)
**	25	2 (8%)	3 (12%)	4 (16%)
***	467	57 (12.2%)	/	85 (18.2%)
****	38	11 (28.9%)	2 (5.3%)	11 (28.9%)
*****	12	1 (8.3%)	/	6 (50%)

* nuclear medicine
 ** profesionas on hemodynamics
 *** radiologists and technicians
 **** professionals in tritium applying industry

Table No.1.

compared to those exposed to sealed sources of irradiation with the same duration of the exposure. Additionally, the presence of symmetrical chromatid interchanges and triradials may be frequently observed in persons dealing with radionuclides. This type of aberration is otherwise extremely rare in professional exposure to unsealed sources of radiation. A high incidence of such changes was encountered in a group of routinely controlled workers, with urine tritium contamination evidenced several years ago (2), chromatide interchanges were found only in patients with dicentric and rings. All of them received a certain dose of ionising radiation. Since a large number of investigators state that chromatide aberrations are probably a consequence of "non-radiation" events (1), we would like to indicate to the fact that they may be the

consequence of ionizing radiation effects. In both groups dealing with radionuclides several subjects with higher number of chromosomal aberrations are noticed. One of the important factors influencing this result was the cumulative effect of ionizing radiation. The second important factor was the radiation type and activity, as well as the type of diagnostic method, therapeutical approach or technological procedure (3).

A whole range of radioisotopes are being used in nuclear medicine and research laboratories. With the application of higher activity isotopes the risk increases. This especially concerns the risk of internal contamination with radionuclides. Special attention must be given to personnel education and planning of appropriate working premises for work with radionuclides, which will provide maximal protection.

CONCLUSION

Dicentric aberrations indicate significantly greater incidence (25-28% of cases analysed) in the group dealing with radionuclides when compared to those exposed to sealed sources of radiation (8-12% of cases analysed), with the similar duration of professional exposure. Dicentric frequency in professionals depends on the source of radiation, working conditions and applying of radiological protection measures.

REFERENCES

1. IAEA. 1986. Biological Dosimetry: Chromosomal Aberration Analysis for Dose Assessment. Technical Reports Series No 260 International Atomic Energy Agency Vienna.
2. Markovic B., Joksic G., Panov D. 1987. Chromosome Aberration Analyses in a Group of Workers Dealing With Radioluminous Paints. XIV-th Regional Congress of IRPA: Current Problems and Concerns in the Field of Radiation Protection. proceedings, pp 45-48.
3. Nuclear Medicine. Geneva 1976. Report of Joint IAEA/WHO. Expert Committee on the Use of Ionizing Radiation and Radioisotopes for Medical Purposes (Nuclear Medicine). Techn. Rep. Ser. 591. WHO, Geneva.
4. United Nations Scientific Committee on the Effects of Atomic Radiation. 1982. Report to the General Assembly, with annexes: Ionizing Radiation, Sources and Biological Effects.

PRELIMINARY REPORT OF A FETAL-THYROID OVEREXPOSURE CASE DUE TO THE
ADMINISTRATION OF I-131 DURING THE SECOND TRIMESTER OF PREGNANCY

Giménez J. C.^(1,2), Gutierrez S.⁽²⁾, Alcaraz G.⁽²⁾
Comisión Nacional de Energía Atómica⁽¹⁾

Sistema de Atención Médica de
Accidentados con Radiaciones Ionizantes⁽²⁾

República Argentina

INTRODUCTION

Sixty to eighty per cent of patients with Graves' disease have antibodies directed against thyroglobulin or against thyroid microsomes. A contemporary interpretation is that thyroid stimulatory immunoglobuline TSI mimics the action of TSH and stimulate the synthesis and release of thyroid hormone. In patient whose thyroids are capable of responding to such a trophic stimulus, TSI may be the mediator of hyperthyroxinemia. TSI cross the placenta and cause transient hyperthyroidism in some neonates (0,5-1 %) born to mothers who have high circulating levels of the antibodies.

As regards adults aged 25 and up, administering I-131 radioactive iodine seems to be a satisfactory treatment for Graves' disease. Such a treatment, however, is to be avoided when treating either pregnant or breast-feeding women due to the effects that irradiation is likely to cause to the fetus or the suckling child. Even though such effects depend on the intrauterine developmental stage, the principal effects are as follows: (a) The embryo may be lethally affected; (b) Malformations and structure changes, or changes in the child's development are likely to occur; (3) The child may be mentally retarded; (4) An induction to cancer and leukemia is possible, and (e) Hereditary effects may be expected.

Moreover, it is a well-known fact that the fetal thyroid is able to capture and integrate iodine as of the 10th/12th gestation week. Thus, administering I-131 according to prescribed doses may define or suppress the thyroid function. Therefore, the highest precautions must be taken in order not to carelessly administer I-131 therapeutic doses to pregnant women. Any woman within the reproductive capacity range should be strongly advised that a pregnancy test is to be performed to avoid her fetus being irradiated. Precisely, the present paper deals with the inadvertent administering a I-131 therapeutic dose to pregnant woman with Graves' disease whose child -unexpectedly enough- turned out to be suffering from hyperthyroidism.

A CASE STUDY

Patient with thyroid background on the maternal side.

After a stressful situation during year 1988, patient evidences the characteristic signs and symptoms of hyperthyroidism, namely: ophthalmopathy, and diffuse goitre, confirmed by an I-131 catchment and hormonal measurements. Results obtained in 1988 were

as follows: TSH < 0.5 uu/ml ; T3 = 800 ug/dl; t4 = 19.8 mcg/dl;
Catchment % = 11 - 51 - 68

Patient is treated with 30-45 mg methilmercaptioimidazol q.d.. However her compliance is quite poor. In 1989, patient comes back to consultation after having suspended the treatment: She is clinically toxic. Again, she is prescribed 45 mg methilmercaptioimidazol q.d.- she nonetheless relapses in poor compliance. In 1990, a new examination is performed, appearing a toxic symptomatology. Patient, however, denies being pregnant: She claims she has been having her menses up to August 1990. Thyroid catchment was 58-100-96 %. Patient is administered a I-131 therapeutic dose, i.e. 5 mCi (185 MBq).

COURSE OF PREGNANCY

Later, during a clinical control, an abdominal palpation reveals a 5-month pregnancy. An abdominal echography certifies a 23-week gestation, which allows us to guess that the I-131 dose was administered during patient's 17th-pregnancy-week. During her 34th week, patient is referred to SAMARI (The Spanish acronym stands for Medical Care System for the Exposed to Ionizing Radiations). Clinically as well as biochemically speaking, patient evidences normal thyroid values: TSH = 0.17 uU/ml; T4L = 1.3 mcg/dl. Fetal heart rate is 180/min with a positive vagus response coinciding with the 110/min maternal pulse rate. A rear-located placenta is seen on echography. A puncture of amniotic liquid is performed with a measuring of TSH 0.16 uU/ml which was a normal value at that time. Fetal heart rate was between 150/170 pulse/min. A new puncture of amniotic liquid evidenced that the liquid was macroscopically mature, with a slightly higher TSH value = 0.4 uU/ml, with vernix caseosa. Echography allowed to see the distal ossification nuclei of a femur as well as the proximal ossification nuclei of a tibia: Those results allowed us to disregard a possible fetal hypothyroidism diagnosis.

CLINICAL CHARACTERISTICS OF THE NEWBORN INFANT

With a normal delivery, a 50-cm long, 2.600-kg, and 9-10 Apgar boy is born alive. As per a clinical examination the gestational age is deemed to be 42 weeks.

The newborn infant evidences ophtalmigthisis, goitre, a point-like fore fontanelle, and a closed rear fontanelle. Infant is irritable, with tachycardia (FC = 170/min); tachypnea (FR=60/80/min) and high blood pressure (120-60) mmHg. The infant progress is shown on table I. As of age 3-month up to now, infant evidences clinically and biochemically normal thyroid values.

RADIOLOGICAL EVALUATION

Doses estimates in fetus for different iodine radioisotopes have been developed for individuals with normal thyroid values. Such models, however (2,3) failed to consider the metabolic differences of female patients suffering from Graves's disease. Taking incorporation and retention in patients suffering from Graves's disease, M.G. Stabin et al (4) have developed a model allowing a dose estimation in hyperthyroid patients who were

administered I-131. The model affords a dose estimate in the whole body of the fetus involved as well as the fetal thyroid. A dose in the whole fetal body from maternal organs was estimated, considering that the bladder contributes with 70 % of the total dose, for a maximum incorporation of thyroid. The dose in the whole body of a 17-week fetus, and 100 % of maternal catchment was estimated in 4.25 mGy. Even with the worst conditions being assumed, such a dose implies a risk lesser than $1.7 \cdot 10^{-5}$ of mental retard as well as another much lesser risk ($1.19 \cdot 10^{-4}$) of cancer in childhood. Estimating the dose in the fetal thyroid as of 3-month old up to 9-month old infants was taken from two different sources, namely: An estimate adapted by Watson (5) assuming a biological $T_{1/2}$ constant in the fetal thyroid at any age range, and an estimate by Elsasser (6) accepting a biological $T_{1/2}$ varying all over gestation.

According to the proposed dose factors, an estimated dose in the fetal thyroid at the 17th week could be included between 40.7 and 101 Gy. If the inorganic iodine distribution space is shared between mother and fetus, the offer of I-131 should be similar for both involved. Assuming that the fetal thyroid is more radiosensitive (7) than the maternal thyroid, hypothyroidism is likely to be expected. Surprisingly, however, the newborn infant we are referring to was with hyperthyroidism. We are lacking a dose-effect relation for the induction of hyperthyroidism in the fetal thyroid. C. Schümichen (8) estimates 463 MBq to be the minimum activity inducing a permanent hypothyroidism. Applying Watson's, and Elsasser's dose measuring factors, such activity would correspond to a dose included between 101 and 254 Gy in the fetal thyroid.

There exist very few cases of an I-131 treatment carelessly administrated during the late semester of a gestation in literature. Only 3 similar cases have been found by our research team: They deal with female patients suffering from Grave's disease that were administered 536.5, 296, and 225.7 MBq, respectively, with 53, 63, and 83 % catchments in the maternal thyroid, respectively (9, 10, 11). The newborn infants corresponding to the first and second case study were hypothyroidic. The third case -i.e. the closest to our case -was a newborn infant who was thyroidically normal. Such case received a lesser activity, with a higher catchment of the maternal thyroid. It is necessary to keep in mind that, whenever adults are involved, a threshold dose likely to induce hypothyroidism within a 5-year lapse of time after I-131 has been incorporated, is 10 Gy. It is compulsory that the child involved be followed up during his or her growth process for an early detection of hypothyroidism thus avoiding its repercuting on the intellectual development by means of an adequate treatment. It is quite possible that the higher TSI levels in the mother induced a maximum catchment of I-131 with a lower "offer" to the fetal thyroid than the one producing hypothyroidism.

It is also compulsory to have all countries strictly ruling that a pregnancy test be applied to hyperthyroidic women within the reproductive capacity age range before they are administered therapeutic doses.

In such cases where a careless administering of I-131 in pregnant women during the first semester or early last three months of pregnancy has occurred, the results of the evaluations should be published.

REFERENCES

1. ICRP Publ. 60 1990 Recommendations of the ICRP Effects on the embryo and fetus.
2. Berman M., Braverman L.E., Burke J. Summary of current radiation dose estimates to human from radiiodines as sodium iodide. *J. Nucl. Med.* 16:857-860, 1975.
3. Johnson J. R. Fetal thyroid dose from intakes of radiiodines by the mother. *Health Phys.* 43:573-582, 1982.
4. Stabin M.G., Watson E.E., Marcus C.S., et al Radiation Dosimetry for the adult female and fetus from Iodine-131 administration in Hyperthyroidism. *J.Nucl.Med.*32,5:808-813,1991
5. Watson E. Radiation dose estimates to the human fetal thyroid at various stages of development(Abstract)*J.Nucl.Med.*24:39,1983
6. Elsasser U. et al. Specific absorbed fractions an S-factors for calculating absorbed dose to embryo and fetus. In Fourth International Radiopharmaceutical Dosimetry Symposium. Oak Ridge Associated Universities 155-166,1986.
7. Pfannenstiel P., Andrew G. A., Brown D. W. Congenital hypothyroidism from intrauterine I-131 damage. In current topics in thyroid research. Acad.Press Inc. N. Y. 749-758,1965.
8. Schumichen C. Schwangerschaft und hochdosierte Radiojodtherapie *Der Nuklearmediziner* 3:8,183-192, 1986.
9. Fisher W. D. Congenital hypothyroidism in infants following maternal I-131 therapy. *J.Pediat.* 62 :132-146,1963.
10. Green H.G. Cretinism associated with maternal sodium iodide I-131 therapy during pregnancy. *Am.J.Disease in Children* 122,247,1971.
11. Hodges R.E. The accumulation of radioactive iodine by human fetal thyroids. *J. Clin.Endocrinol.and Metab.*15: 661-667, 1955.

TABLE I

Age	Treatment	TSH μUL/ml	T4 mg/dl	T3 mg/dl	AFM TB11 %
Umbilical cord	-	<0.15	24	280	1/400
8-hr	Blood letting/Dilution				
4-day	-	<0.15	17	150	1/400 99
18-day	Propranolol 4 mg/d Sodium iodate 500 mg/d	<0.15	24	350	
24-day	Propranolol 4 mg/d MMI 5 mg/d	<0.15	21	230	
28-day	" "	<0.15	12	115	
61-day	Treatment is suspended	0.4	4.8	110	4
3-month	-	0.4	12.8	neg	

GUIDELINE VALUES FOR SKIN DECONTAMINATION MEASURES BASED ON
NUCLIDSPECIFIC DOSE EQUIVALENT RATE FACTORS

Drs. H. Pfob*, G. Heinemann **

* Head of the Medical Department of Badenwerk AG,
75 Karlsruhe 1, Germany

** Head of the Medical Department of PreussenElektra,
2160 Stade, Germany

ABSTRACT

Corresponding dose equivalent rate factors for various radionuclides are now available for determining the skin dose caused by skin contamination. These dose equivalent rate factors take into account all contributions from the types of radiation emitted. Any limits for skin decontamination measures are nowhere contained or determined yet. However, radiological protection does in practice require at least guideline values in order to prevent unsuitable or detrimental measures that can be noticed quite often. New calculations of dose equivalent rate factors for the skin now make the recommendation of guideline values possible.

INTRODUCTION

While German and international ordinances call for limiting values for protective measures where surface contamination of workplaces and objects has occurred, they do not contain any limits for skin decontamination measures. The resulting danger is that decontamination measures that are unsuitable or too expansive could harm the skin or encourage incorporation. That is why radiological protection in practice does at least require guideline values to limit decontamination. Prerequisite for this is the possibility of determining the skin dose. On the basis of new calculations, we have now a list of dose equivalent rate factors for the skin of 611 and all nuclids relevant for radiological protection. Following this, guideline values can be recommended. Moreover, findings on the intake of radioactive substances into the skin and their transport through the skin have to be taken into account. Between these two limits - the unreasonable skin dose on the one hand and the incorporation through measures of decontamination - are the reasonable measures of the decontamination of individuals.

THE COMPILATION OF A RECOMMENDATION BY THE GERMAN COMMISSION
ON RADIOLOGICAL PROTECTION

By order of the German Commission on Radiological Protection a team of specialists developed a recommendation "Measures to Be Taken in Cases of Radioactive Contamination of the Skin" in the years 1988 and 1989, which was published by the Secretary of the Environment, Ecological Protection and Reactor Safety on March 3rd, 1990. The team could refer to the results of discussions in the Professional Association for Radiological

Protection Inc. and the Association of Specialists for Radiological Protection Medicine about the limiting of measures of decontamination based on practical experience in nuclear power plants and on dermatological findings.

Major points of the recommendation are:

- Derivation of a Guideline Value for Measures where Skin Contamination Has Occurred
- Transport of Radioactive Substances into and through the Skin
- Preventive Measures for the Avoidance or Limitation of a Contamination
- Organization and Execution of Skin Decontamination in the Practical Work of a Company
- Possible Radiation Exposure of Medical Staff when Treating Contaminated Patients

DETERMINATION OF THE SKIN DOSE

The dose equivalent rate factors take into account all contributions from the types of radiation emitted (alpha-, beta-, gamma-, and AUGER-radiation). When calculating the dose equivalent rate factors, it is assumed that the layer of the skin regarded as sensitive to radiation is usually 50 - 100 μm below the surface. With the help of the dose equivalent rate factors, the local skin dose can be calculated by multiplying these with the surface-related activity on the skin (in Bq/cm^2) and with the duration of contamination (in seconds), taking into account the respective half life.

The German Commission on Radiological Protection takes into account the following presumptions for the calculation of a guideline value:

- The major part of the activity concentrates on the skin surface. Its amount is crucial for the dose.
- The activity that has penetrated the horny layer decreases very quickly (exponentially with a half-value thickness of around $2\mu\text{m}$).
- The remaining activity stays on the skin in its full strength for a week. This is a very conservative assumption. In fact, the complete horny layer undergoes full exfoliation within two weeks. Hence there is a rapid decrease of the activity situated in the higher layers of the cornea.

DERIVATION OF A GUIDELINE VALUE

The primary limit for skin contamination of 300 mSv in any one calendar year is used as a basis when deriving a guideline value. This guideline value should provide a sufficient safety distance even if

- the contamination appears several times a year
- there are uncertainties regarding the dose determination on a daily basis
- there are contributions from radioactive daughter nuclides which are not included in the contamination measurement.

These aims are guaranteed by a simple, practicable and easily remembered guideline value for surface-related activity of 10 Bq/cm² (averaged over 100 cm², where the contamination is largely distributed over the entire area). Further decontamination measures are not required below this value. This means that for more than 90% of the nuclides listed, including those of relevance to radiological protection, less than 1% of the aforementioned annual dose limit is reached with a retention time of one week. Moreover, with one exception (Cf 254), all doses are less than 5% of this limit. The doses even are significantly lower if contamination is quickly and fully eliminated.

The uniform guideline value of 10 Bq/cm² should also be applied to those radionuclides which, due to the short range of their radiation, do not make any contribution to the dose of the layer of skin regarded as radio-sensitive. This constitutes sufficient provision against risks caused by the spreading of radioactive substances outside the controlled area. In this context, it is assumed that cases of persistent residual contamination are very rare and that any remaining activity adheres firmly to the skin. Special reflection is necessary where contamination spreads beyond the surface of a person's head or hands.

TRANSPORT OF RADIOACTIVE SUBSTANCES INTO AND THROUGH THE SKIN

The skin represents an effective, but not completely impenetrable barrier against radioactive substances. As long as a liquid wets the surface of the skin, substances are transported from the surface into and through the skin. The activity absorbed by the horny layer and its transport through the skin (permeation) are proportional to the activity concentration of the liquid and to the size of the area of skin affected, as well as the amount of time the contaminating liquid is on the skin. The horny layer absorbs about one microliter of liquid per cm², and thus the activity contained therein.

CONSEQUENCES FOR THE PRACTICAL WORK OF DECONTAMINATION

As the amount of time that a radioactive solution is on the surface of the skin is important, the removal of the contaminating liquids should be commenced as quickly as possible and must halt any further deposition in the skin and reduce permeation through the skin. The incorporation, however, can only play a role where a very large area of the body is affected and where there is a long period of contamination with high activity concentrations.

In principle, preventive measures to avoid or limit contamination represent the most effective form of protection. Preventive measures include regular checks on the condition of the skin and constant personal skin care, for a healthy skin offers the best protection against percutaneous incorporation of radioactive substances. German nuclear power plants, for example, check the condition of the skin in several steps: the

yearly radioactive protection checks by the company physician, monitoring by the radiological protection officer at the entrance to the control zone and - most importantly - self-monitoring by the individual plant-member. Additional protective measures specific to the workplace are recommended, for example the wearing of protective clothing or specific measures of skin care. The measures of decontamination recommended by the Commission on Radiological Protection can be summed up by the following formula: begin with the simplest measures, but aim them directly to the part of the body affected.

Low levels of contamination can usually be eliminated in one step by washing with water. Wherever possible, only the contaminated areas of the skin should be washed with lukewarm water. Usually the palms of the hands have to be washed first. The exact diagnosis of contamination that can also be done by the automatic exit monitor and the directed measure of decontamination are among the most important basics of the catalogue of measures recommended by the German Commission on Radiological Protection.

If single cases make contamination measures that are above simple washing with warm water necessary, the radiological protection officer and authorized physicians should be consulted. These measures should be classified as medical treatment.

REFERENCES

1. Maßnahmen bei radioaktiver Kontamination der Haut, Bundesanzeiger Nr. 45 vom 6.3.90, S.1081-1084
2. Heinemann, G. und Pfoh, H. (1991). Empfehlungen zur Personendekontamination, in: Strahlenschutz für Mensch und Umwelt, 25. Jahrestagung des Fachverbandes für Strahlenschutz e.V., Aachen. 688-694. FS-91-55-T
3. Henrichs, K., Kaul, A. und Seelentag, W. (1983). Berechnung von Dosisfaktoren bei der Kontamination der Haut und der Kleidung, in: Strahlenschutzaspekte bei radioaktiven Kontaminationen, 17. Jahrestagung des Fachverbandes für Strahlenschutz, Aachen. FS-83-32-T, 125-136
4. Möhrle, G. (1972). Erste Hilfe bei Strahlenunfällen. Schriftenreihe Arbeitsmedizin, Sozialmedizin, Arbeits-hygiene. Bd. 47. Gentner Verlag Stuttgart
5. Pfoh, H. (1990). Bericht über die Ergebnisse des SSK-Arbeitsgruppe zur Personendekontamination, in: Strahlenschutz in der nuklearmedizinischen Diagnostik. Strahlenschutz in Forschung und Praxis. Bd. 31. Gustav Fischer Verlag
6. Pratzel, H., Dirnagl, K. und Drexel, H. (1984). Kontamination der menschlichen Haut durch Radionuklide. Nucl.-Med. 23, 197-200
7. Schieferdecker, H., Henrichs, K. und Koelzer, W. (1985). Vorschlag für die Ableitung von Grenzwerten für die Hautkontamination und -dekontamination. GSF Bericht 11/85. GSF S-1232

CYTOCHEMICAL INVESTIGATION METHODS AS A CONTRIBUTION
DIAGNOSTING LEUKOCYTE TRITIUM DAMAGE

S. Milačić, S. Dodić and V. Nikolić

University clinical center
Institute of Occupational and Radiological Health-
Belgrade

ABSTRACT

The study analyses cytochemical characteristics of neutrophilic granulocytes. Alkaline phosphatase and myeloperoxidase activity was semiquantitatively determined from capillary blood smears stained acc. to Kaplow. Lipids content was examined with Sudan black B staining. The results of these cytochemical reactions are significantly different ($p < 0,05$; Mann-Whitni U-Test). Score values negatively correlate with absorbed doses but not linearly so that these methods contribute to diagnosing irradiation damage of granulocytes; but they do not have biological-dosimetric importance.

INTRODUCTION

Tritium, a radioactive isotope of hydrogen is widely used in numerous different scientific and economic fields. The specific role of tritium application is seen in so called "scintillating colours" which are mixtures of different, especially prepared, tritium compounds, so that they have a property of producing greenish scintillations. Having in mind the energy of tritium beta particles, the high activities are needed to accomplish this effect. Tritium is easily evaporable and contaminates the working environment. After the exposure, regardless to the way of penetration (respiratory or digestive tract, skin), it is easily found in blood circulation and is evenly distributed in all tissues and organs, as a component included in water metabolism. Biological half-life of elimination is 4-18 days. Leukocytes cytochemical properties were studied in workers exposed to scintillating colours, contributing in diagnostics of tritium induced damages.

MATERIALS AND METHODS

We analysed the number of neutrophilic granulocytes and values of cytochemical parameters in 21 tritium exposed workers and 11 controls. Capillary smears were stained for alkaline phosphatase activity by Kaplow's method, for peroxidase activity by benzidine reaction and for lipides by Sudan black. The intensity of staining is directly proportional to the extent of chemical reaction which is determined by microscopy on 100 cells and expressed as a score. On the basis of chromosome aberration the assessed absorbed irradiation dose is 0.12-0.59 Gy.

RESULTS AND DISCUSSION

The number of neutrophilic granulocytes is not significantly changed in tritium exposed workers (T-test for the small statistical group, $p > 0.05$) while the alkaline phosphatase (APL) and peroxidase (MFO) scores are significantly lower ($p < 0.05$, Mann Whitney's U-test). There is no significant changes in Sudan reaction (Table 1).

Table 1.

The number of neutrophils, APL, MFO and SUD scores in tritium exposed workers and controls

Examined group	n	N	NPL	MFO	SUD
E	21	3,2	36	148	214
K	11	3,8	58	196	224
p		0,7NS	0,05S	0,05S	0,3NS

APL score correlation with the absorbed dose is significant and correlation coefficient is 0.46. (Short 1). MFO score correlation with absorbed dose is negative, but statistically insignificant while Sudan reaction was not in correlation with the dose.

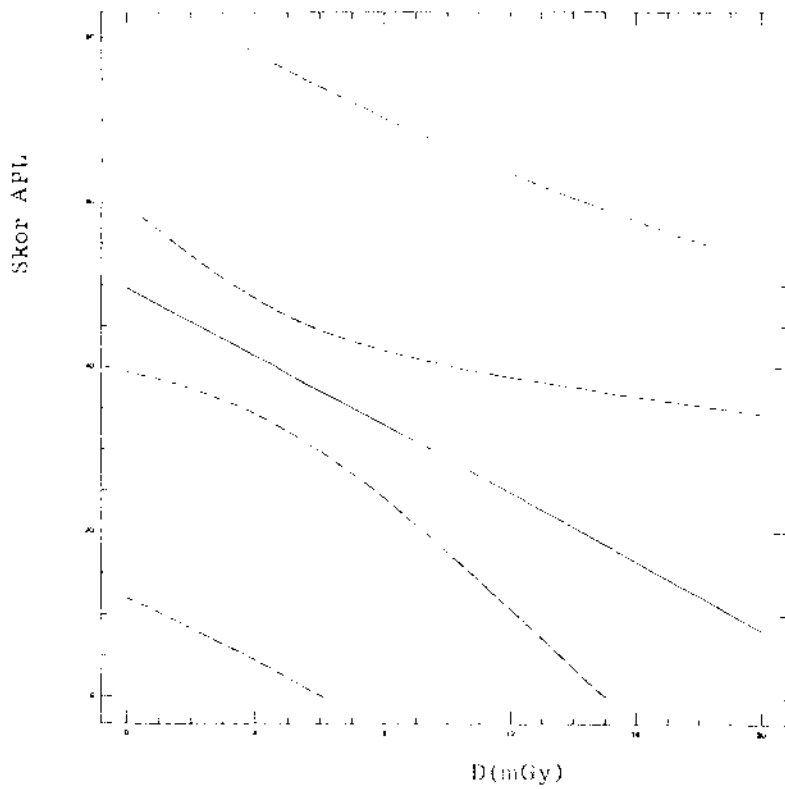

Figure 1.

The correlation of APL scor
with the absorbed dose
($r = - 0.46$)

Cytochemical reaction to alkaline phosphatase and peroxidase suggested significant tritium-influences changes in leukocytes when their number was unchanged. Both scor-values correlation with the dosis showed that the reaction intensity is decreased together with the dosis, although not linearly, therefore, they can't be used for biodosimetry. No changes were shown in Sudan reaction, thus it was insignificant in diagnostics of leukocytes damages induced by tritium, i.e. beta irradiation.

CONCLUSIONS

Applied cytochemical reactions to ABL and NPO are semiquantitative and easily followed tritium effects on exposed workers leukocytes which could help in early diagnosing of its function impairment related to body defence reactions.

REFERENCES

1. Martin J. Cline: Leukocyte function, Churchill Livingstone New York, Edinburgh, London and Melbourne, 1981.
2. Micu D., Mihailescu, Vilan C., et al.: The value of some cytoenzymochemical investigations of the leukocytes and platelets in estimating the effects of occupational exposure to benzene, vinyl chloride and carbon disulphide, N. Gh. Lupu. Institute of Internal Medicine, 72202 Bucharest ROM-REV Romm. Med. ser Med. Int., 1985 23/2 (115/120)
3. I.B. Ekin: Problemi radiacionoj citologii, Leningrad, 1984.
4. P. Dri, R. Gramer, M. R. Sorenzo, A. Comin, V. Miotti, and P. Patriares New Approaches to the detection of myeloperoxidase deficiency, Blood, Vol. 60, No 2, 1982, (323-327)

CLINICAL CRITERIONS FOR BIOSIMETRY AT WORKERS EXPOSED TO LOW DOSES OF
IONIZING RADIATIONS

Nikolic,V.Joksic,G.Milicic,S.

University Clinical Center of Belgrade

Institute of Occupational Medicine and Radiological Health

Deligradska,29

11000 Belgrade

Yugoslavia

In the course of routine general examination of workers who work under the circumstances of exposition to the low doses of ionizing radiations,15 of them with clinical indications were underwent to chromosome aberrations analyze,such as 64 workers without any clinical indications.In the first group there were 40.6% of subjects with increased frequency of chromosome aberrations,against the only 7.5% in the second group.Considering the kind of the ionizing source,it could be noticed the higher frequency of chromosome aberrations at nuclear medicine workers (27.7%),against the workers exposed to the sealed sources (9.8%).According to our results we consider the justification of clinical indications for chromosome aberrations analyze,as the very specific biosimetric procedure.

INTRODUCTION

Chromosome aberrations analyze is of particular importance for estimation of ionizing radiations absorbed doses during the accidents (1).For the professional exposition,chromosome aberrations analyze has qualitative nature (confirming the effects of some radiation dose),and it is the case of possible irradiation indicated by medical criterions and biosimetric data (2).Clinical criterions are decisive for further biosimetric investigations during the general health examination of workers exposed to ionizing radiation.In the most cases it is appearance of presenile incipient bilateral cataract or some malignoma.More often there are present nonspecific discomfords,such as exhaustion,fatigue,headache,bad appetite for food all followed by some hematological disorders.Almost,it is always leucopenia with inverse leucocyte ratio,persisting hypochromic anemia,isolated thrombocytopenia and sometimes the immunodeficiency,all mentioned above without any other etiology.

Among the others indicators of chromosome aberrations,it is also personal dosimetry data showing the exceeding of annual (monthly) limit dose of radiation for professionals.Clinical criterions are completed with data about the kind of ionizing source and the time of professional exposition.

RESULTS

Based at the clinical criterions,15 subjects were underwent to chromosome aberrations analyze.All of them showed the most of the nonspecific discomfords,10 subjects had leucopenia (4 of them less than $4 \times 10^9/L$),and

5 of them (50%) had relative leucopenia followed by lymphocytosis. Only 1 person had presenile incipient cataract. There were no cases of malignant disease. The time of professional exposition was between 5 and 15 years.

Among these 15 subjects, there were 5 of them who showed dicentric chromosome (200 cells in the first in vitro partition by one subjects were analyzed), and 2 persons showing chromatide interchanges and triradials. The next 2 persons showed acentric fragments (within allowed limits for professionals considering the annual and monthly maximal dose). In this group, there were 40.6% of subjects with increased frequency for chromosome aberrations.

The chromosome aberrations analyze was performed at second group of 64 workers during the general health examination with no clinical indications. There were found dicentric chromosomes at 4 subjects (6.0%), only one person (1.5%) showed chromatide interchanges, and 10 persons (15.6%) had acentric fragments. In this group, there were 7.5% of subjects with increased frequency for chromosome aberrations.

If the both analyzed groups would be considered according to the ionizing radiation source (see table 1), the significantly higher frequency of chromosome aberrations (27.7%) could be noticed at the group of nuclear medicine workers, against to the workers exposed to sealed source of ionizing radiation (with similar time of exposition and working operations), showing the 9.8% of persons with increased frequency for chromosome aberrations.

CHROMOSOMAL ABERRATIONS AT THE GROUP OF PROFESSIONALS EXPOSED TO SMALL DOSES OF IONIZING RADIATION				
	number of cases analyzed	with dicentric	with chromatide interchanges	with other aberrations
professionals selected by medical indications	18	5 (33%)	2 (10.6%)	2 (10.6%)
professionals in the course of routine examination	64	4 (6.%)	1 (1.5%)	10 (15.6%)
professionals exposed to radionuclides	18	2 (11.1%)	3 (16.6%)	3 (16.6%)
professionals exposed to sealed sources	61	6 (9.8%)	/	11 (18%)

TABLE 1

CONCLUSION

According to our results, it could be emphasized the role of well selected clinical indications by experienced clinician, as the very important indicator for performing complex biological tests (in this case it is chromosome aberrations analyze). This attitude needs to be supported by more strictly and continuous biodosimetric supervision at subjects exposed to small doses from opened source of ionizing radiations.

BIBLIOGRAPHY

1. IAEA, 1986. Biological Dosimetry: Chromosomal aberrations analyze for dose assessment. Technical reports. Series No 260. International Atomic Energy Agency, Vienna.

2. United Nations Scientific Committee on the Effects of Atomic Radiation, 1982. Report to the General Assembly with annexes: Ionizing radiation. Sources and Biological Effects.

A CASE STUDY OF AN ACCIDENTAL INHALATION OF Am-241
FROM A RUPTURED SOURCE

J Kruger, P J Kruger, D J J C Bouwer and J Albasini
Atomic Energy Corporation of SA
Pretoria, Republic of South Africa

ABSTRACT

Four workers who were involved in the accidental inhalation of americium-241 were monitored over a period of 660 days post-accident. DTPA treatment commenced on day 1 and was sustained up to 100 days. From measurements on the initial respiratory deposition, the chest and lower abdominal regions, faecal and urinal excretions, initial intakes from 7,8 to 54,4 kBq were estimated. Lung clearance with half-lives of approximately 1,50 and 500 days were identified. No significant bone deposition was measured. Committed effective dose equivalents were estimated from 2 mSv to 74 mSv for the four individuals concerned.

INTRODUCTION

During a routine transfer operation in August 1987 the encapsulation of a commercial 37 GBq (1 Ci) americium gamma source was accidentally ruptured, resulting in an air-borne release of americium oxide aluminized powder. Significant external contamination was identified on the three operators involved in the operation (cases 1, 2 and 4) and on a Health Physics technician called in after the accident (case 3). Referral to a Phoswich chest counter on the same day confirmed significant intakes. A monitoring programme was effected from day 1 post-accident. As the initial measurements on day 0 indicated possible intakes of up to 50 times Annual Limit on Intake (ALI), the individuals were also placed under medical supervision from day 1 and a DTPA treatment programme was initiated in consultation with the medical officer.

MONITORING PROGRAMME

A monitoring programme to identify the intake and initial respiratory deposition, the deposition and excretion patterns over the first few days, and the deposition and excretion patterns over an extended period of time was initiated from day 0 and maintained up to 660 days post-accident or until minimum detection levels were reached.

The initial respiratory deposition on day 0 was measured with a 7,6 cm (3") diameter NaI crystal over the upper nasal passage N-P region (as defined in ICRP-30 lung model¹), and a 25,4 cm (10") diameter CsI-NaI Phoswich detector posterior over the chest region (i.e. partly the trachea-bronchial (T-B) region and the pulmonary (P) region). 24-hour faecal and urine samples were collected and gamma-counted directly with a Ge-Li detector over the first 3 days. Posterior lower abdominal counts with the Phoswich detector were also initiated from day 1 onwards.

Deposition in the chest area was measured, initially daily, then weekly and eventually monthly using the Phoswich chest counter. Measurements on the lower abdominal region were similarly performed to determine partly chest deposition and removal and G-I tract clearance, and most important, liver deposition. A minimum detection level of 20 Bq for the Phoswich arrangement was estimated. 24-hour faecal and urine samples were collected at regular intervals, ashed and gamma-counted with a Ge-Li detector. A minimum detection level of 1 Bq/day was estimated. A procedure for alpha-counting to improve detection limits was unsuccessful.

MEDICAL TREATMENT

Treatment with DTPA chelating agent intravenously injected started on day 1 with 0,25 g Ca-DTPA, followed from days 2 to 5 with 0,5 g daily²⁾. From day 6 onwards Zn-DTPA became available and replaced Ca-DTPA. Treatment continued from days 6 to 9 with 0,5 g daily, days 12 to 35 twice weekly and thereafter twice weekly for cases 1 and 2 and once per week for cases 3 and 4 up to 61 days, and then once per week for cases 1 and 2 up to 103 days. Treatment was stopped at stages where no further chelating advantage was considered applicable. Strict medical supervision was maintained throughout the treatment period.

MONITORING RESULTS

Days 0 to 4: Results over the first few days are summarized in Table 1. It shows the initial deposition pattern and a fast 0,5 to 1 day rapid excretion through the faeces. This excretion through the G-I tract was confirmed by the abdominal measurements.

Table 1

	Case 1	Case 2	Case 3	Case 4
Initial upper N-P deposition in kBq (day 0)	13,7	3,2	3,4	0,5
Initial chest activity in kBq (day 0)	7,2	5,3	1,1	5,9
Total faecal excretion 0-4 days in kBq	36,7	38,8	4,0	1,5
Total urinary excretion 0-4 days in Bq	189	214	30	12

Day 4 onwards: The monitoring points for chest activity are given in Figures 1 and 2, and the daily urinary excretion measurements in Figures 3 and 4. In Figures 1 and 2, C designates the cases, i.e. C1 is case 1, and R designates a least squares fit with slopes 2 (intermediate) and 3 (long term). In Figures 3 and 4, C again designates the cases but D_p is the calcu-

figure 1. CHEST COUNTS

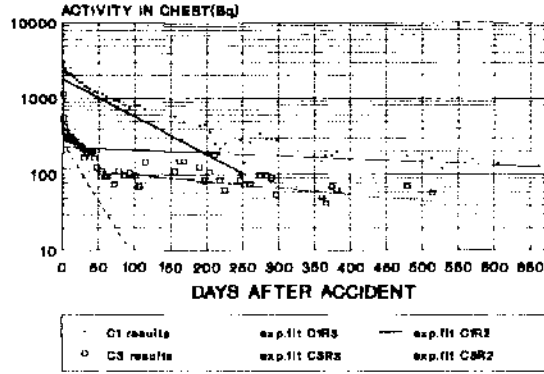

figure 2. CHEST COUNTS

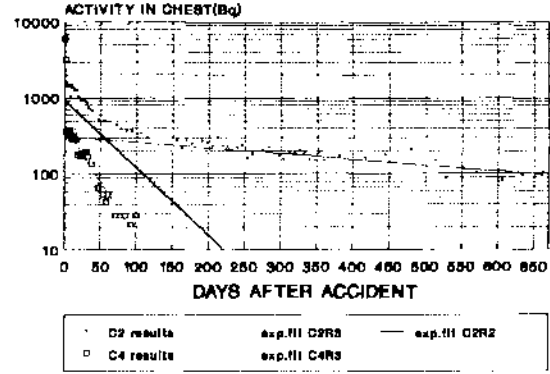

figure 3. URINARY EXCRETION

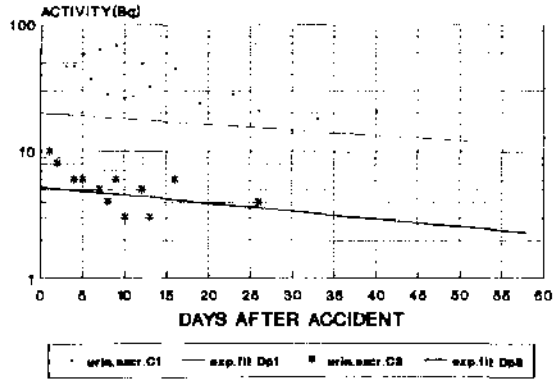
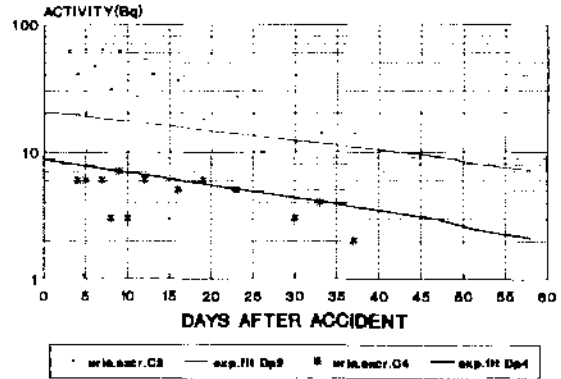

figure 4. URINARY EXCRETION



lated daily decrease in lung pulmonary deposition for each case.

Three lung clearance half-lives were identified, a short one at 0,5 to 1 day, an intermediate one at approximately 50 days (i.e. 70 days, 40 days and 30 days respectively for cases 1, 2 and 3) and a long one at approximately 500 days (i.e. 700 days, 450 days and 350 days). Abdominal measurements supported the excretion patterns found, and showed no liver deposition. Efforts to identify bone deposition were, within the limitation of detection levels, all negative.

DISCUSSION

Experimental measurements sufficiently confirmed the ICRP-30 lung model to warrant using the model to assess intake, removal and dose commitments. Deviations in case 4 could be ascribed to an emphysema condition. Using results in Figures 1 and 2 to define the initial pulmonary depositions and using initial chest measurements, total faecal excretion and the lung model total intakes were determined for cases 1 to 4 as 54,2 kBq, 48,3 kBq, 7,8 kBq and 6,4 kBq. A particle size of approximately 5 μ m was estimated.

From Figures 3 and 4 it can be seen that the urinary excretion closely followed removal from the lung for the intermediate clearance rate (50 days). This was confirmed by no deposition in liver or bone being detected. It was concluded that during this period no significant bone or liver deposition occurred. Deposition in bone on the long term after cessation of DTPA treatment was estimated by assuming that all chest activity from then on deposited in bone and liver. A committed bone dose equivalent of 4,2 Sv and a committed effective dose equivalent of 233 mSv were estimated for the worst case (case 1). It must be noted that such deposition was not in fact experimentally confirmed.

CONCLUSION

After the inhalation of Am-241 from a commercial gamma-source, followed by a DTPA-chelation treatment up to 100 days, lung clearances with half-lives of approximately 0,5 day, 50 days and 500 days were identified. No liver or bone deposition was detected within measurement limitations. Committed effective dose equivalents as a result of lung exposures were calculated for cases 1 to 4 as 74, 45, 12, and 2 mSv respectively.

REFERENCES

- 1 ICRP Publication 30. 1978. Pergamon Press.
- 2 B D Breitenstein: Medical Management and chelation therapy. Health Physics. Vol 45, October 1983, 855.

MONITORING OF URINE BY EXTRACTION CHROMATOGRAPHY WITH
TRI-N-OCTYLPHOSPHINE OXIDE SUPPORTED ON A POLYPROPYLENE COLUMN

N. Bonino, J. Diodati, M. R. Cena

Gerencia de Seguridad Radiológica y Nuclear
Comisión Nacional de Energía Atómica
Buenos Aires- Argentina

ABSTRACT

Monitoring of personnel working with 20% enriched uranium implies development of techniques for excreta analysis, mainly for urine, with very low detection limits.

The method described allows the determination of 20% enriched uranium after extraction in tri-n-octylphosphine oxide (TOPO), 0.5 M in toluene, supported on polypropylene capillary columns [1]. Alpha activity is later measured in a low background liquid scintillation equipment [2] and the fluorescence in a fluorimeter [3], with detection limits, for 500 mL of urine, of 15.0 ± 4.0 mBq L⁻¹ and $5 \times 10^{-2} \pm 10^{-2}$ µg L⁻¹.

INTRODUCTION

The control of 20% enriched uranium in the urine of workers requires periodic analysis of a large number of samples from different areas. Since the radiological risk is very important, it is necessary to rely on a technique able to detect levels well below the values established in the monitoring of natural uranium and adapted to the performance of a large number of determinations. Kel-F columns in reversed phase partition chromatography were used to purify urine [4], as well as extraction with organic compounds such as tributylphosphate (TBP) or bis-2-ethylhexylphosphoric acid (HDEHP) [5], with adjustment of the media prior to measurement.

The microcapillary chromatographic technique using TOPO as the supported phase is very adequate to concentrate uranium since this selective reagent, in permanent contact with the solution, enhances the extraction of uranium through a stable complex formed. As elution with toluene is performed instead of stripping, losses are minimized so that the efficiency in the application of the sample, regulates the efficiency of the column. The eluate is a purified solution, 160 times more concentrated than the original sample. Fluorimetry and gross alpha activity by low background liquid scintillation are performed on different aliquots.

REAGENTS AND EQUIPMENT

Nitric acid, Cicarelli pa.
Hydrogen peroxide, Douglas pa.

Tri-n-octylphosphine oxide, Mallinckrodt A.R.
Ethyl alcohol pa.
Toluene scintillation grade
Naphthalene scintillation grade
PPO scintillation grade
Sodium fluoride, Merck pa.
Calcium orthophosphate dibasic solution (100 mg mL⁻¹)
Ammonium hydroxide, Merck pa.
Polypropylene PR-125
Jarrell Ash 26000 Fluorimeter
Platinum dishes
Fusion furnace, 1300 °C
Beckman LS-3150 T Liquid Scintillation, equipped with a low background system.

EXPERIMENTAL

Mineralization of organic matter

10 mL of concentrated nitric acid and 3 mL of calcium orthophosphate dibasic solution are added to 800 mL of urine in a beaker. The solution is left at 60 °C for one hour. Ammonium hydroxide is slowly added while stirring up to pH = 10. The precipitate is digested overnight, centrifuged and the supernatant discarded. The solid is mineralized to white ashes on a hot plate with 1:1 nitric acid and hydrogen peroxide. The ashes are dissolved in 80 mL of 1M nitric acid and hydrolyzed for one hour at near boiling temperature.

Setting the chromatographic column

The chromatographic column, 5 m long, is coiled downwards on a cylindrical plastic support 50 mm diameter. The microcapillar of 1.2 mm of internal diameter is imbibed with 300 µL of a 0.5 M solution of TOPO in toluene. The column is previously washed with ethyl alcohol and vacuum dried.

Loading and elution

The cooled hydrolyzed liquid is poured through the column, previously treated with 1 mL of 1 M nitric acid, at a rate of 20 drops per minute and the contents are eluted into a liquid scintillation vial with 5 mL of toluene. Three 200 µL aliquots are used for fluorimetry and 5 mL of a scintillation cocktail containing 10 g of PPO and 160 g of naphthalene in 1000 mL of toluene are added to the remaining solution into the vial and it is measured by low background liquid scintillation. A blank of urine and a recovery test are run together with the urines and measured in the same conditions.

RESULTS

The following considerations were taken during the standardization of the technique:

Pyrophosphates formation

The pyrophosphates formed during mineralization tend to compete with TOPO for the uranium, resulting in very widespread recovery values. To avoid this interference an acid hydrolysis

is performed during one hour.

Urine volumes

Volumes of urine ranging from 200 to 2000 mL were processed, with no influence in recovery values. Volumes of 1 M nitric acid used to solubilize the ashes varied accordingly, since 10 mL of 1 M nitric acid are needed for every 100 mL of urine. 800 mL of urine are adequate regarding both detection limits and amount of sample to be requested.

Capillary length

Capillary tubes 1, 3 and 5 m long were used. Recoveries were poor in the first case, improved in the second case but were not reproducible. Columns 5 m long proved to be optimum regarding high recoveries and reproducibility.

TOPO concentration

Recoveries did not change in the 0.5 to 1.0 M concentration range and a 0.5 M value was adopted. Since the minimum amount of extractant needed to imbed the whole column was 300 μ L, this was the volume chosen.

Percolation rate

There were no significative changes in recovery values for flow rates ranging from 20 to 40 drops per minute, but recoveries were very low for rates over 50 drops per minute.

CONCLUSIONS

Since the concentration factor is high enough to detect very low uranium levels, this technique is suitable for controlling personnel working with different uranium compounds. Besides, it is very convenient when dealing with many samples in different matrixes, because measurements are done immediately after elution, requiring only the addition of the scintillation mixture.

REFERENCES

1. Eschrich, H and Hansen, P. The Applied of Open Capillary Columns to Extraction Chromatography Separations. ETR-239 (1969).
2. Campos, J. M., Alzabet, H., Di Trano, J. L., Treppa, W. A. Determinación de Uranio en Orina por Centelleo Líquido por Discriminación por Formas de Pulsos NT/86. Comisión Nacional de Energía Atómica. Buenos Aires, Argentina.
3. Kramer, G. H., Johnson, J.R. and Green, W. The Measurement of Natural Uranium in Urine by Fluorimetry. Chalk River, Ontario. February 1964. AECL-8251
4. Hamlin, A. L., Roberts, B. J., Loughlin, W. and Walker, S. G. Analytical Chemistry. Vol. 33 - No 11. October 1961. pp 1847.

5. Braun, T., Ghersini, G. (ed). "Extraction Chromatography". Amsterdam, Netherlands. Elsevier, 1975. pp 100.
6. Grind, W., James, E. The Radiochemistry of Uranium. NAS-NS3050/1962. pp 151.

DIAGNOSIS OF THYROID NODULES AND MEDICAL FITNESS FOR RADIATION WORK:
CASE CONTRIBUTIONS

E.STRAMBI* M.VIRGILI**

* RADIOPROTEZIONE MEDICA, UNIVERSITA' CATTOLICA POLICLINICO GEMELLI,
ROME, ITALY

** RADIOPROTEZIONE MEDICA, USL FR/4, FROSINONE, ITALY

ABSTRACT

The nodular thyroid disease frequently involves delicate diagnostic problems, in particular concerning the diagnosis of thyroid cancer. Therefore, in case of a palpable thyroid nodule the physician must first of all perform the proper procedures (ultrasonography, scintigraphy, fine-needle aspiration biopsy, etc.) for a selective approach to diagnosis, as a necessary step before an eventual surgical treatment.

MANAGEMENT OF THYROID NODULES

In this study are discussed the first results obtained by the application of the decision matrix for the management of a thyroid nodule, which has been suggested in previous work (see fig.1).

According to that protocol, workers professionally exposed and known as carriers, at the moment of preventive or periodical visit, of alterations of the glandular morphology have been tested with scintigraphy, ¹³¹I thyroid uptake and eventually T₃ suppression test in case of doubtful differential diagnosis between hot and cold nodules. Ultrasonography has been performed to distinguish between cystic and solid cold nodules. In case of solid nodule serum calcitonin level could erase the doubt to be in presence of a medullary thyroid carcinoma.

In presence of cold and solid nodules a fine-needle aspiration biopsy has been performed to diagnose malignant nodules, benign nodules or follicular neoplasms.

Malignant nodules and follicular neoplasms have been referred directly to the surgeon.

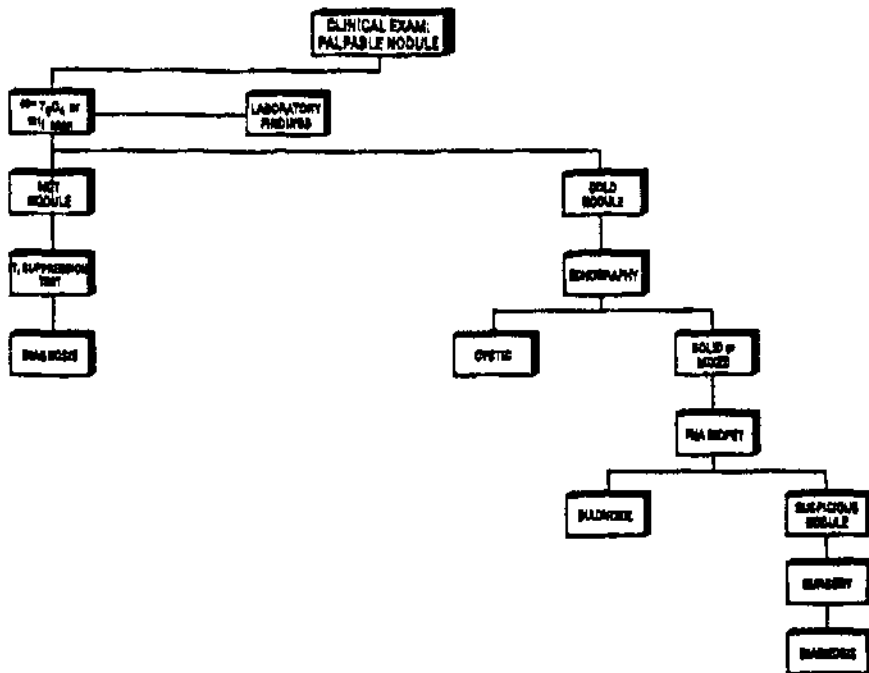

Fig. 1. DECISION MATRIX FOR WORKUP OF A THYROID NODULE

CASE DESCRIPTION

In this study are presented 34 cases of palpable thyroid alterations regarding patients observed in the last 3 years. The following diagnoses have been made:

- a) isolated nodules - 18 cases of which: 4 colloidal nodules, 4 pure cysts, 2 hyperfunctioning adenomas (one autonomous, the other not autonomous), 1 follicular adenoma, 1 papillary carcinoma; in the remaining 6 cases the diagnostic procedure at the moment has not been completed
- b) simple goiter - 7 cases
- c) multinodular goiter - 8 cases

DIAGNOSTIC DISCUSSION

Ultrasonography has allowed to exclude the presence of nodular formations in 2 cases of goiter with palpable irregularities and to recognize as multinodular 2 situations that, based exclusively on the clinical findings, should have been defined as uninodular. For this purpose, it must be noted that the multinodular goiters, even if they sometimes contain suspicious nodules that deserve the same caution of a solitary nodule, have a much smaller probability of cancer compared to the solitary nodules. Hot nodules, that as a rule are not malignant, have not been suspected of malignancy. However, it has to be emphasized that such nodules, although rarely, can hide follicular, papillary and even medullary carcinomas.

For this reason serum calcitonin level and eventually also fine-needle aspiration biopsy should be performed in such cases. Also cystic nodules, that as a rule are not cancer, have not been considered suspicious of malignancy, but since cancer is occasionally found in the wall of the cyst, it has been thought necessary the ecographic surveillance of cystic lesions at the moment of each periodical visit.

Considering the limits of fine-needle aspiration biopsy in the pre-surgical differential diagnosis between follicular adenoma and follicular carcinoma, we have referred to the surgeon the case of follicular adenoma and the case of papillary carcinoma.

The diagnostic scheduled procedure suggested by us then is based on the clinical finding of a palpable nodule. However, it has to be emphasized that the possibility to clinically diagnose the presence of thyroid nodules depends on their size that must be less than 1 cm., while the resolution of ^{99m}Tc pertechnetate scan with the pinhole collimated gamma camera is about 0,5 cm. and the resolution of small parts echography is about 1 mm.

Ultrasonography is of immense value in the early diagnosis of tumors, since it can easily identify small tumoral lesions already in a pre-clinic phase. Consequently, a systematic application of this technique in the medical surveillance of radiation protection on each exposed worker could be proposed.

However it must be considered that a patient with a thyroid carcinoma not clinically detectable (occult) has no risk of metastatic spread

of the tumor, that as a rule remains confined in situ. Therefore, as far as thyroid gland is concerned a systematic application (not aimed) of ultrasound against stochastic effects would not find adequate justification in a correct evaluation of cost/benefits balance.

In conclusion, we think that the physical exam, moreover undoubtedly facilitated by the superficial position of the organ should usually represent the main diagnostic procedure, reserving the instrumental tests to who presents palpatory anomalies.

The 2 cases of follicular adenoma and papillary carcinoma in particular show how the diagnostic protocol suggested above could become useful also from the point of view of the secondary cancer prevention, which is one of the main goals of the radiation protection.

MEDICAL JUDGEMENT OF FITNESS FOR RADIATION WORK

In case of a patient known as a carrier of a thyroid nodule clinically detectable, the physician first of all must approach a precise diagnosis. Before the examinations have been completely performed, the judgement should generally be "in observation" and the subject will be consequently maintained as a rule at his normal work in controlled area without any limitation, considering the possible doses to thyroid outcome from radiation work. At the end of the instrumental diagnostic procedures, as has been said above, anytime surgical treatment is needed for a diagnostic and therapeutic reason, the eventuality that the subject will or will not accept the surgical treatment must be faced. In this last case should not automatically outcome a judgement of unfitness, but the potential risk and actual real damage resulting from such a judgement should be evaluated case by case.

As far as risks are concerned, it should not be considered the possibility of a nodular cancerous degeneration caused by work exposure to ionizing radiation (hypothesis with no probability), but the possibility that in reality we are dealing with a carcinoma not detectable at the moment with the used techniques.

The last hypothesis can involve in some psycho-social contexts the possibility of future legal controversies and therefore can justify a more restrictive judgement.

In any case, as far as the medical judgement of fitness for radiation work is concerned, one has to keep in mind some main criteria, i.e. the clinical findings; the specific risk evaluation; the social, economical and psychological parameters.

Thus, in his evaluation, the physician should always consider the risk/benefits balance.

THE DEVELOPMENT OF NRPB ADVICE FOR THE DISPOSAL OF SOLID RADIOACTIVE WASTE

J R Cooper, I M Barraclough and S F Mobbs

National Radiological Protection Board, Chilton,
Didcot, Oxon, UK, OX11 0RQ

In the past, problems have been encountered in the practical application of radiological protection principles to solid waste disposal. In order to aid in the interpretation of existing advice and to encourage improvements in the presentation of safety cases for solid waste disposal facilities, NRPB has updated and clarified certain aspects of previous advice. Among other things, it is recommended that, for the purposes of risk assessment, the future should be divided up into time frames, with the emphasis of the assessment changing as the period of prediction increases.

1. INTRODUCTION

As a result of past recommendations by ICRP and others, the basic radiological protection principles for determining the acceptability of disposal facilities for solid radioactive wastes are now well established: namely the optimisation of protection and the limitation of individual risk. Furthermore, it is widely accepted that individuals who might be alive at any time in the future should be accorded a level of protection at least equivalent to that which is accorded to individuals and populations alive now. Nevertheless, there are particular problems in applying such basic principles to solid waste disposals. These problems arise in part because of the long time periods, often hundreds of thousands of years, over which radionuclides could be released into the biosphere from a solid waste disposal site. As a consequence, the rate of release may depend upon events and processes which have probabilities associated with them (eg, faulting in a rock formation) and, furthermore, the exposure of individuals alive in the future will depend upon their habits which are difficult, if not impossible, to predict.

In order to aid in the practical interpretation of existing advice, particularly in the light of ICRP's 1990 recommendations^[1], the UK National Radiological Protection Board, a UK Statutory Advisory Body, is updating its advice for the disposal of solid radioactive wastes. The proposed advice applies to land-based disposal in engineered facilities as described in detail in a consultative document^[2]. The purpose of this paper is to describe some aspects of this advice.

2. LIMITATION OF INDIVIDUAL RISK

In the case of solid waste disposal it is difficult to apply any standards, which are based solely on dose limitation because it will generally be possible to envisage circumstances, even if they have a low probability of occurrence, which if they were to occur would lead to doses above any selected limit. Therefore, the quantity to be limited is individual risk where risk is defined as

the probability that a dose will be received x the probability that the dose will give rise to a deleterious health effect

A risk limit could be derived directly from the dose limit, however, this would not be strictly appropriate to solid waste disposal. Such a risk limit would pertain to the sum of the risks from all sources to an individual; instead risk limitation is achieved by setting risk constraints for each source. The constraint is an upper bound on the optimisation of protection for that source to prevent unacceptable risks to individuals who are exposed to more than one source.

3. ASSESSMENT OF INDIVIDUAL RISK IN THE FUTURE

In order to ensure the protection of future generations it is usually necessary to assess the risks to individuals over long timescales. However, the sophistication of the assessment methods should reflect the confidence which may be attached to the assumptions made in the assessment. This confidence will tend to decrease as the timescale of the assessment increases and therefore it may be appropriate to change the emphasis of the calculations relating to the far future. One way to achieve this is to divide the time period of the assessment into the following series of time frames with the level of calculational detail being changed in each successive time frame:

i) *Site operation and up to c 100 years after closure*

This period is the 'institutional control period' and it is assumed that the relevant dose limits will apply.

ii) *c 100 years to c 10,000 years*

This period represents the time between the end of institutional control and the next major environmental 'event' such as glaciation. For this period 'predictive' models can be used to simulate the transfer of radionuclides through the geosphere and biosphere to a hypothetical critical group. This group should be reasonably homogeneous and representative of those individuals likely to be exposed to the greatest risk. The assumptions about human behaviour should be representative of the type of area being studied but not site-specific.

iii) *c 10,000 years to c 1,000,000 years*

In this time period the uncertainty associated with any detailed calculations related to the biosphere is likely to be so great that an appropriate approach is to define and model an arbitrary 'biosphere' populated by a 'reference community' with reasonably conservative habits such as subsistence farmers. Thus, by requiring a hypothetical reference community to be 'protected', a reasonable degree of assurance will be provided that any real communities which actually exist will not be subject to unacceptable risks. In this time period, the criterion could be expressed as probability weighted releases of radionuclides from the geosphere.

iv) *After c 1,000,000 years*

This is the approximate lifetime of the human race to date. The scientific basis for risk calculations in this time frame is therefore questionable and NRPB recommends that assessments covering longer time periods should concentrate on qualitative discussions.

4. HIGH CONSEQUENCE EVENTS

The treatment of risk described above only applies to situations where exposures are somewhat less than those which would give rise to deterministic effects (eg, <0.5 Sv). However, in the case of disposal of high level waste and, perhaps, intermediate level waste, situations could be envisaged, albeit improbable ones, where deterministic effects could be experienced. These situations could arise if the waste was brought to the surface by direct human intervention. Requirements to limit the consequences of such improbable events are not desirable; to modify a repository design solely for compliance with such a limit would not be sensible, particularly as such modifications might otherwise detract from the performance of the repository. Therefore, it is suggested that waste disposal sites should be chosen and facilities designed so that the total probability of all events having the potential to lead to doses which would cause deterministic effects should be as low as reasonably achievable.

5. TREATMENT OF UNCERTAINTY

Uncertainty can originate from several sources including, for example, inadequate knowledge of the future behaviour of the disposal site or lack of knowledge of the value for a particular parameter in a model. It is important to present and discuss separately the uncertainties arising from different sources. As an aid to this, it is suggested that uncertainty as to the future evolution of the site could be addressed by selecting a range of scenarios to represent qualitatively different futures. Each of the scenarios should then be assigned a probability, to represent the relative likelihood of that scenario actually occurring. Parameter uncertainty analysis should be undertaken to determine the confidence in the results for each scenario.

6. OPTIMISATION

The main radiological input to optimisation has generally been integrated collective dose. Even with relatively short integration times, collective dose estimates are so dependent on human behaviour that predictions must be treated with caution: with integration times of thousands of years the values are meaningless. Some alternatives have been suggested by ICRP^[3] including truncation and discounting, however there are disadvantages to each of them.

To assist in clarifying these issues, NRPB have suggested that a design target, set at a level of individual risk sufficiently low to be of very little concern, may be used as a guide to the extent of optimisation study required. If the estimated risks from a facility are likely to exceed this target,

then a full demonstration that the proposed facility is the optimum solution for that particular waste would be required. However, if the estimated risks are below the target, then the optimisation requirement may be confined to the detail of facility design. In the latter situation the release of radionuclides to the biosphere could be used as a surrogate for collective dose in the optimisation.

7. CONCLUSIONS

The ideas described in this paper will form the basis of NRPB's formal advice on the radiological protection aspects of the disposal of solid radioactive wastes in land-based facilities in the UK. It is hoped that the adoption of these ideas will lead to a clearer understanding of the issues and to a more transparent presentation of safety cases.

REFERENCES

1. ICRP. 1990 Recommendations of ICRP. Publication 60. Annals of the ICRP, Vol 21, No 1-3 (1991).
2. NRPB. Consultative Document: Radiological Protection Objectives for the Land-based Disposal of Solid Radioactive Wastes. NRPB-M279, (1991).
3. ICRP. Radiation Protection Principles for the Disposal of Solid Radioactive Waste. Publication 46. Annals of the ICRP, Vol 15, No 4 (1985).

**LONG-TERM UNCERTAINTY IN RADIOLOGICAL PERFORMANCE ASSESSMENTS
OF LOW-LEVEL WASTE FACILITIES AT THE SAVANNAH RIVER SITE**

L. M. McDowell-Boyer

Health and Safety Research Division
Oak Ridge National Laboratory

ABSTRACT

Radiological performance assessments are being conducted for the Saltstone Disposal Facility and the E-Area Vaults at the Savannah River Site near Aiken, South Carolina. Saltstone is a solidified waste form which will contain very low levels of radionuclides but considerable levels of nitrate. The E-Area Vaults will contain solid, radioactively contaminated waste. Preliminary results of the assessments indicate that adequate performance will be very sensitive to the degradation scenario adopted for the cover and containment systems for these facilities.

INTRODUCTION

The U. S. Department of Energy (DOE) Order 5820.2A (DOE 1988) requires a site-specific radiological performance assessment for each DOE low-level waste (LLW) disposal facility designed and utilized subsequent to issuance of the order. The purpose of an assessment is to demonstrate compliance with performance objectives for DOE LLW management established in the order. In addition to ensuring compliance with other DOE Orders addressing radiation exposures and U. S. Environmental Protection Agency (EPA) regulations for atmospheric releases, these performance objectives include protecting groundwater resources consistent with federal, state, and local requirements.

Oak Ridge National Laboratory has been tasked with doing radiological performance assessments of the LLW Saltstone Disposal Facility (SDF) and E-Area LLW Vaults at the Savannah River Site (SRS) in a joint effort with the Idaho National Engineering Laboratory and Hanford. The most challenging aspect of these, and perhaps all, performance assessments involves predicting the long-term performance of the various engineered features of the waste-forms, containment, and closure designs over the time period for which significant quantities of radionuclides are present in the facilities. There is no specific regulatory guidance on the length of time for which potential exposure must be predicted nor on the amount of uncertainty which can be tolerated.

THE SRS LLW SALTSTONE DISPOSAL FACILITY AND E-AREA VAULTS

The SRS was acquired by the U. S. government in 1950 and covers approximately 780 sq km in southwestern South Carolina.

The site receives over 100 cm of rainfall annually and thus is classified as a humid subtropical region. As is the case with other sites in the DOE complex, waste management and environmental restoration have come to the forefront of activities at SRS in the last decade.

Both Z-Area and E-Area are on topographic highs which slope toward surrounding creeks. The historic high water table lies at a minimum of 7 m below the existing grade at Z-Area, and 6 m below the existing grade at E Area. The groundwater under both facilities discharges largely to the local creeks, such that off-site contamination of groundwater is unlikely to be significant. A lower regional aquifer is protected from downward migration of contaminants by a thick impermeable zone. Discharge of contaminated groundwater to surface water may carry contaminants off-site, but dilution in streams provides a large amount of protection to potential water users.

The SDF handles disposal of liquid waste streams which are solidified in a cement matrix. Radionuclides of consequence in the liquid waste include H-3, Cs-137/Ba-137m, Ru-106/Rh-106, Sr-90/Y-90, Tc-99, and I-129. A slurry consisting of a high nitrate-content salt solution, Portland cement, flyash, and slag is piped into below-grade concrete vaults. Upon solidification of the resulting monolith of saltstone, the remaining headspace will be filled with clean cement, and the vaults will be protected from infiltration until final closure with various overburden layers. Nitrate is present in the saltstone product at very high concentrations (about 7 wt%) and thus is of potential concern from the standpoint of the EPA's drinking water standard of 10 mg/L for NO₃ as N.

The E-Area Vaults will receive discarded trash, equipment, and machinery that have been contaminated by low levels of radioactivity. Tritium, C-14, Co-60, Cs-137/Ba-137m, Mn-54, Ni-63, Se-75, Sr-90/Y-90, and Zn-65 are the nuclides of potential concern. With the exception of C-14, none of these radionuclides are long-lived. Most of the nuclides will have decayed to stable isotopes by 300 years. Long-lived radioactive isotopes of uranium and transuranics are expected to be present in waste received by the E-Area Vaults only in very minor amounts. Primary containment will be in the form of metal boxes or drums for smaller items. Larger items will be placed directly into the concrete vaults along with the metal boxes and drums. A sloping concrete cover completes each vault. Separate vaults for storage of tritium and waste contaminated by C-14 are planned for this facility.

When all vaults are full at both facilities, earthen covers, designed to minimize infiltration of rainwater and

intrusion by roots or burrowing animals, will be placed over the entire facilities.

ANALYSIS

Demonstration of compliance with DOE Order 5820.2A requires that pathways to potential receptors be identified and potential exposures be predicted over an indefinite period of time. This must be done for three recognized time periods of concern: the operational time period (about 30 years for the SDF and 20 years for the E-Area Vaults), the post-closure institutional control time period (about 100 years), and the post-institutional control time period. Potential receptors fall into two categories: on-site receptors, or inadvertent intruders, and off-site receptors. During institutional control, on-site receptors are not present as the site boundaries are still maintained.

After 120 or 130 years, the possibility of excavation or drilling into the facilities by inadvertent intruders must be considered. Intact, or non-degraded, concrete vaults are fairly robust from the standpoint of external exposure to on-site receptors. The massive concrete buffer (almost 0.5-m-thick vault walls and ceilings) around the saltstone monolith and E-Area waste forms makes damage due to well drilling or excavation highly unlikely.

As stated in DOE Order 5820.2A, the SDF and E-Area Vaults must be designed to meet federal, state and local requirements for the protection of groundwater, as well as satisfy the other requirements for controlling radiation exposures. The EPA's drinking water standard (EPA 1990), which is being applied to groundwater for the purpose of evaluating compliance, limits the annual dose received from groundwater contaminated by radionuclides to 4 mrem and specifies maximum contaminant levels for various chemical compounds such as nitrate. This is the limiting requirement for LLW facilities like the SDF and E-Area Vaults if mechanical intrusion into the facility is not credible.

Over long periods of time, however, it is expected that natural processes may degrade the cover and containment systems so that infiltration into the facilities is increased and the ability of the Saltstone monolith or E-Area waste forms to withstand leaching is increasingly compromised. Erosion of ground surfaces, intrusion by burrowing animals or plant roots, and seismic events are potential sources of disruption of infiltration barriers. Cracks in the concrete vaults and the saltstone monolith may increase leaching to an unacceptable degree, and the concrete vaults may eventually crumble.

Because many of the radionuclides in the both facilities

are relatively short-lived, it is possible that they will have decayed to insignificant levels by the time natural processes have compromised the containment of the facility to any significant degree. Long-lived Iodine-129, Tc-99 and nitrate are, however, of concern for the SDF.

Much of the uncertainty in the results of individual exposure analyses as a consequence of LLW disposal lies not in the wide range in values of quantifiable parameters but in the wide range in credible scenarios describing conditions at the facilities hundreds to thousands of years into the future. There is not an official time cutoff for calculating exposures for DOE radiological performance assessments, and uncertainties become unfathomable after the first several hundred years due to poorly understood mechanisms of degradation of engineered barriers.

CONCLUSIONS

Despite the large amount of precipitation received annually by the SRS, the use of multiple barriers in disposal of LLW at two facilities at the site appears to provide both a workable solution to the common problem of subsidence in waste disposal facilities and a means of radically reducing the leachability of wastes. However, because long-lived radionuclides and non-decaying substances of concern may outlast the lifetime of engineered containment, their presence may adversely impact the performance of these facilities at some time in the future.

Degradation of engineered systems must be addressed in performance assessments. Recognizing that there is considerable uncertainty arising from the limited knowledge of degradation mechanisms and timing, there must be a concerted effort by both technical personnel involved in designing LLW facilities and policy makers and regulators to address this large uncertainty. Design of facilities should acknowledge the inevitability of degradation of protective and containment features. Policy makers and regulators must address the issue of the amount of uncertainty that will be tolerated in performance evaluations and the length of time that should be considered in assessing performance.

REFERENCES

- DOE, 1988. *Radioactive Waste Management*, DOE Order 5820.2A, U. S. Department of Energy.
- EPA, 1990. "National Primary Drinking Water Regulations," 40 CFR 141, U. S. Environmental Protection Agency.

**ORGANISATION GENERALE d'EDF POUR LE
CONDITIONNEMENT ET L'ENTREPOSAGE DES DECHETS DE
FAIBLE ET MOYENNE ACTIVITE**

Y. FITAMANT

Electricite de France
Service de la Production Thermique
D.S.R.E. - Saint-Denis

**GENERAL ORGANISATION OF EDF ABOUT TREATMENT,
CONDITIONING AND INTERMEDIATE STORAGE OF LOW
LEVEL OR INTERMEDIATE LEVEL ACTIVE WASTE**

Managing wastes is a vital activity of EDF

EDF is responsible for managing wastes until the final storage which is done by the ANDRA.

In its management of radio-active wastes, EDF applies the same quality approach as for its other nuclear power plant operations.

The goal is to specify the quality required to comply with fundamental safety rules, to obtain this quality by adequate ways and means at every link in the waste chain and to prove that this quality level is really obtained.

All these actions, supported by powerful computer facilities, contribute to maintain the safety level which was planned at the design stage, and this has made it possible to substantially reduce the volumes and the cost of wastes sent to storage.

1 - AVANT - PROPOS

Le Manuel d'Organisation de la Qualité en Exploitation, document national destiné aux centrales nucléaires a été mis en application en 1977. Il comporte des prescriptions concernant la collecte, le conditionnement, le transport et le stockage de déchets radioactifs solides.

En 1983, le document EDF/SPT - Règles de base et Manuel National d'Organisation de la Qualité - Chapitre 5.2. - traitement des déchets radioactifs - confirme les prescriptions et pratiques du précédent manuel et prend en compte une évolution dans le domaine des déchets radioactifs dont la création de l'ANDRA.

Au-delà de la stricte application des règles, la qualité en exploitation repose avant tout sur l'organisation du travail mise en place et sur la compétence du personnel qui exécute les diverses activités.

2 - ORGANISATION GENERALE

. A partir des principes du Manuel National d'Organisation de la Qualité et règles de base, chaque centrale rédige un ensemble de notes d'Organisation qui constituent le Manuel d'Organisation de la Qualité de la centrale.

. Une note d'organisation définit les responsabilités et les relations entre les différents acteurs impliqués dans le traitement des déchets radioactifs.

. La manière de conduire les tâches élémentaires fait l'objet de gammes d'exécution et de consignes d'exploitation. Les tâches sont réalisées par un personnel dûment formé, habilité et désigné.

3 - APPLICATION

Les différents éléments qui concourent à la qualité d'un colis de déchets radioactifs concernent :

- les approvisionnements des conteneurs et matériaux,
- la collecte des déchets,
- l'évaluation de la radioactivité contenue dans les colis,
- le conditionnement,
- l'entreposage avant expédition,
- l'expédition vers le centre de stockage.

3.1. - Les approvisionnements des conteneurs et matériaux

Chaque approvisionnement est régi par un cahier des spécifications et des conditions techniques (C.S.C.T.) qui définit tous les critères contribuant à la qualité du produit fini.

Afin d'assurer un suivi des approvisionnements entrant dans l'élaboration des colis, E.D.F. a imposé à ses fournisseurs de mettre en oeuvre une organisation de la qualité, qui fait l'objet d'une acceptation puis de contrôles.

Pour chaque matériel ou matériau entrant dans le cadre de cette organisation, une fiche de suivi est ouverte et un numéro d'identification est attribué.

3.2. - La collecte des déchets

A EDF, tous les déchets provenant de zone contrôlée sont considérés comme potentiellement radioactifs.

3.2.1. - Déchets de procédé

Une fiche de suivi est initiée pour tous les déchets de procédé.

3.2.2. - Déchets technologiques

Les sacs de transport de déchets technologiques de faible activité sont étiquetés pour en connaître la provenance.

Pour chaque type de déchets, une fiche de suivi particulière est rédigée.

C'est au moment de sa collecte que la composition radiologique du déchet est déterminée.

3.3. - L'évaluation de radioactivité contenue dans les colis

. La politique mise en oeuvre par EDF, en matière de limitation de radioactivité de l'eau du circuit primaire, conduit à ne pas développer la présence, en quantité significative, de radio-éléments émetteurs "Alpha" dans ce circuit.

De ce fait, hors anomalie grave au niveau du combustible, le respect des spécifications techniques d'exploitation permet de garantir que le niveau d'activité "Alpha" dans les colis est toujours compatible avec les critères d'acceptabilité du centre de stockage et ne nécessite pas de traitement particulier.

En cas d'anomalie grave, le devenir des déchets solides est à discuter cas par cas avec l'ANDRA.

. Détermination de l'activité des différents radionucléides :

- Par calcul direct à partir de spectrométrie gamma,
- Par association d'un spectre type et du débit de dose moyen à mi-hauteur au contact du colis. Dans ce cas, le calcul de l'activité est fait à partir d'une "fonction de transfert". Du fait de son caractère national, il est déposé à l'ANDRA.

3.4. - Le conditionnement

3.4.1. - Préparation

Pour la réalisation de cette phase, des gammes sont rédigées à partir des DESCRIPTIFS DE PROCÉDES.

Chaque type d'activité fait l'objet d'une gamme. Les gammes de préparation des colis mentionnent notamment :

- . la méthode de conditionnement à employer,
- . la description des principales opérations à effectuer,
- . l'habilitation des agents concernés,
- . les contrôles,
- . l'évaluation de la radioactivité contenue.

3.4.2. - Exécution

Le conditionnement est découpé en tâches élémentaires, l'exécution d'une tâche ne pouvant être réalisée avant que la tâche précédente ait été effectuée et contrôlée.

3.4.3. - Fiches d'identification de colis

Afin d'assurer le suivi du conditionnement de chaque colis, une fiche d'identification est instruite. Elle permet d'une part de s'assurer que les actions précédant le conditionnement ont bien été réalisées (collecte du déchet, approvisionnement) et d'autre part de suivre l'état d'avancement du colis.

Lorsque cette fiche a été entièrement remplie et contrôlée, le colis correspondant peut être expédié si aucune anomalie n'est mentionnée.

Les opérations de conditionnement des déchets solides sont placées sous l'autorité d'un responsable habilité et désigné.

Dans le cas où les situations d'exploitation conduiraient à produire un colis hors normes, le responsable de l'exécution n'engage pas les opérations de conditionnement de ce colis et en réfère à un agent de responsabilité supérieure qui :

- . décide de la conduite à tenir,
- . mentionne ses décisions et leur justification sur le compte rendu.

Les fiches d'identification de colis permettent :

- . de garantir la conformité des colis au descriptif du procédé correspondant, et de connaître la radioactivité contenue,
- . d'avoir un état précis et repéré géographiquement des colis stockés en attente d'expédition,
- . de faire une comptabilisation par nature des colis préparés et des colis expédiés.

3.5. - L'expédition

Afin d'avoir l'assurance que tous les colis expédiés au centre de stockage ont été conditionnés conformément aux agréments obtenus de l'ANDRA, ils sont identifiés à l'aide d'une numérotation nationale.

Ces numéros sont attribués dès la confection des emballages chez les fabricants, ceci permet de suivre les colis sur chaque site en fonction de leur état et de leur position géographique et d'être ainsi certain de la correspondance entre les documents qui ont été instruits lors du traitement du déchet, et le colis.

3.6. - Le transport

EDF maîtrise le système de transport de ses déchets et applique les principes et règles d'assurance qualité dans ce domaine. Après enquête et évaluation les transporteurs font l'objet d'une acceptation assortie de contrôles périodiques.

4 - MOYENS INFORMATIQUES

Depuis le 31 décembre 1990, la gestion des colis de déchets nucléaires de toutes les centrales est assurée par informatique, grâce au module DRA du schéma directeur informatique du SPT. EDF dispose ainsi d'un logiciel qui centralise toutes les données permettant la déclaration des caractéristiques des colis de déchets nucléaires destinés à être stockés sur les sites exploités par l'Agence Nationale de gestion des Déchets Radioactifs (ANDRA).

Ce programme permet entre autres à EDF de constituer, par échange de données en temps réel avec ANDRA, un stock de colis validés et expédiables. Il constitue également une base de données de tous les déchets produits sur les différents sites.

5 - CONCLUSIONS

L'organisation de la qualité appliquée depuis l'origine à l'outil de production a été étendue aux activités liées à la gestion des déchets radioactifs au-delà de la stricte application des règles. L'esprit qualité qui anime les différents partenaires contribue à maintenir voire améliorer le niveau de sûreté défini à la conception.

POLITIQUE DE GESTION DES MATIERES DE TRES FAIBLE RADIOACTIVITE

A.M. Chapis, Ph. Guetat

Commissariat à l'Energie Atomique
Institut de Protection et de Sécurité Nucléaire
Département de Protection de l'Environnement et des Installations
Fontenay-aux-Roses, FRANCE

VERY LOW LEVEL RADIOACTIVE WASTE MANAGEMENT POLICY

ABSTRACT

Starting from the different studies dealing with very low level waste management we propose a methodology to improve the present regulation. This approach is presented and limits are proposed.

Les réglementations existantes sur la protection des travailleurs et du public contre les rayonnements ionisants précisent clairement les conditions dans lesquelles doivent s'effectuer les opérations de traitement, stockage, transport et élimination des substances radioactives. Le champ d'application de ces réglementations est défini en fonction de la radioactivité des matériaux exprimée en radioactivité totale et/ou radioactivité massique et/ou radioactivité surfacique.

Les matériaux de très faible radioactivité se situent généralement hors du cadre précédent. Leur traitement, recyclage ou stockage soulève des problèmes réglementaires compte tenu du fait que certaines installations n'acceptent pas de "substances radioactives" alors que tout matériau contient des radionucléides d'origine naturelle et éventuellement artificielle.

Il convient donc de déterminer les limites de radioactivité admissible dans les déchets évacués vers les installations d'élimination, de traitement ou de valorisation(1), (2). Ces limites doivent garantir la protection des travailleurs et des personnes du public.

Plusieurs situations peuvent être envisagées selon que les déchets sont acceptés par une installation déterminée ou par une catégorie déterminée d'installations. Dans les deux cas il est possible d'envisager soit l'absence d'obligations (hormis la contrainte concernant le niveau de radioactivité), soit des obligations légères de types administratif et technique. Ces obligations peuvent porter soit sur des contrôles liés à la radioactivité, soit sur la destination des produits ou sous-produits de l'installation.

La détermination des limites de radioactivité acceptables est obtenue à partir des relations entre la radioactivité des déchets et les doses susceptibles d'être reçues par les travailleurs et le public. Ces relations sont déterminées en étudiant toutes les situations conduisant à une exposition des personnes, en évaluant les conditions de ces expositions et en calculant les doses correspondant à une radioactivité unitaire.

Ces calculs nécessitent la connaissance des pratiques industrielles, des conditions de travail, des caractéristiques des déchets de très faible radioactivité et en particulier du volume attendu par rapport aux capacités des installations de traitement.

Il est alors possible, en se fixant des contraintes de dose, de calculer les radioactivités limites qui permettent de respecter ces contraintes. Les contraintes de dose peuvent être égales à la limite de dose pour le public : 5 mSv sur une période de 5 ans, ce qui conduit à une valeur moyenne annuelle de 1 mSv par an si l'exposition est continue (6) ou à une fraction de cette limite (7). Elles peuvent être différentes selon qu'il s'agit des travailleurs ou des personnes du public ou suivant les caractéristiques des groupes critiques considérés (1).

Les résultats de ces calculs permettent également de décider s'il y a lieu ou non de fixer des conditions sur la destination des sous-produits de l'installation (par exemple cendres d'incinérateur ou scories d'aciérie) ou sur l'utilisation des produits de recyclage.

L'Institut de Protection et de Sécurité Nucléaire a réalisé ce type d'études pour différentes catégories d'installations : décharges de résidus municipaux et industriels, aciérie, cimenterie... (3, 4, 5).

L'ensemble des résultats montre qu'il existe pour chaque radionucléide des limites d'activité massique et surfacique au dessus desquelles les doses aux travailleurs des installations conventionnelles pourraient dépasser 1 mSv par an si aucune précaution n'était prise. Au dessus de ces valeurs les déchets sont dits radiotoxiques et doivent être envoyés dans une installation spécialement conçue pour les recevoir. Remarquons cependant qu'il peut exister des installations où, compte tenu des caractéristiques propres de l'installation et/ou du volume de déchets traité, les doses restent inférieures à 1 mSv par an même lorsque l'activité des déchets est supérieure aux limites précédentes.

Au dessous de ces valeurs les déchets peuvent être envoyés dans une installation conventionnelle à condition que leur radioactivité soit inférieure aux limites d'acceptation dans l'installation considérée. Ces limites sont, selon les radionucléides et selon les installations, soit égales soit inférieures aux limites précédentes.

On a vu que les résultats des études fournissent, pour chaque radionucléide, une limite d'activité massique et une valeur d'activité surfacique. Les résultats peuvent être utilisés tels quels. On a cependant examiné s'il était possible de trouver une présentation plus simple. Une première simplification a été obtenue en prenant la même valeur numérique pour l'activité massique (en Bq/g) et l'activité surfacique (en Bq/cm⁻²).

Une seconde solution consiste à regrouper les radionucléides ayant des limites voisines et à constituer des classes homogènes. Compte tenu du grand domaine de variation des valeurs (8 ordres de grandeur) il est nécessaire de définir plusieurs classes (au moins quatre). Cependant ces classes présentent l'inconvénient de ne pas correspondre à la classification actuelle.

Une troisième solution consiste à trouver une formule générale applicable à tous les radionucléides. Elle doit tenir compte des différentes voies de transfert qui conduisent à l'exposition des personnes. La limite d'activité massique correspond alors à la plus faible des valeurs suivantes :

- $100/n$ Bq par gramme ; n étant la proportion de photons d'énergie supérieure à 0,1 MeV émis par désintégration d'un radionucléide donné
- $100/p$ Bq par gramme ; p étant la fluence énergétique des électrons émis par désintégration d'un radionucléide donné (en MeV).
- $5 \cdot 10^{-2}$ de la limite annuelle d'incorporation par inhalation qui lui est applicable, par gramme
- $5 \cdot 10^{-4}$ de la limite annuelle d'incorporation par ingestion qui lui est applicable, par gramme

Le tableau suivant donne ces limites pour quelques radionucléides

Nucléide	Limite Bq/g	Nucléide	Limite Bq/g
C 14	4 10 ⁴	U 238	1 10 ²
P 32	2 10 ²	Th 230	1 10 ¹
Co 60	5 10 ¹	Ra 226	4 10 ¹
Ni 63	1 10 ⁵	Pb 210	1 10 ¹
Sr 90	9 10 ¹	Po 210	5 10 ¹
Cs 137	1 10 ²	Pu 239	1 10 ¹

Les travaux précédents montrent qu'il est possible pour chaque installation ou type d'installations de définir des critères d'acceptation des matériaux ou des déchets qui permettent de respecter les contraintes de dose.

Du point de vue de l'IPSN la gestion des déchets de faible radioactivité comme celle de tout déchet radioactif doit répondre aux exigences suivantes :

- protection des travailleurs et du public,
- responsabilité du producteur de déchets (connaissance de leurs caractéristiques et de leur destination),
- transparence et information de toutes les parties concernées.

REFERENCES

1. Ph. Guetat, A.M. Chapuis, Ph. Vesseron, Modalité d'évacuation des déchets de très faible radioactivité, rapport interne SEPD 90/17, 1990
2. A.M. Chapuis, Ph. Guetat, H. Garbay, Modalités d'évacuation des déchets de très faible radioactivité (politique de gestion - méthodologie - application), congrès SFRP Saclay 5 mars 1991
3. Ph. Guetat, A.M. Chapuis, Ph. Renaud, Disposal of very low level radioactive wastes (VLLW) in conventional industry - Case of landfill for municipal or industrial refuse, Joint International Symposium on Environmental Consequences of Hazardous Waste Disposal, Stockholm, May 27-31, 1991
4. H. Garbay, A.M. Chapuis et al, Impact radiologique dû au cuivre et à l'aluminium très faiblement radioactifs provenant du démantèlement d'installations nucléaires, Rapport EUR 13160 FR, 1991
5. Radiological protection criteria for the recycling of materials from the dismantling of nuclear installations, radiation protection n°43, Luxembourg, 1988
6. ICRP, Recommendations of the commission, ICRP 60, 1991
7. IAEA, Principles for the exemption of radiation sources and practices from regulatory control, Safety Series n°89, 1988

RADIOACTIVE WASTE STORAGE AND DISPOSAL:A THEORETICAL STUDY

Gurinder Singh and H.S.Virk
Department of physics
Guru nanak Dev University
Amritsar-143005(INDIA)

Abstract :-

The application of nuclear energy is especially difficult to grasp and the handling of nuclear wastes is a matter of great concern to an average person. A detailed study is carried out in the field to assure that workers and public are not harmed now or in the future by the effects of radiation from the wastes, that the environment is not polluted and that the financial cost of handling and disposal of wastes is not excessive. The study is particularly important as it involves social aspects such as health and safety, environmental protection, national defence and energy needs.

**OPTIMISATION DU PRINCIPE ALARA EN MATIERE DE GESTION ET
D'ELIMINATION DE DECHETS RADIOACTIFS DE TRES FAIBLE ACTIVITE**

A. Réqibeau, J. Caussin, M. De Spiegeleer, M. Poelaert.

Université Catholique de Louvain,
Service de Radioprotection,
2, Chemin du Cyclotron,
B.1348 Louvain-la-Neuve

**OPTIMIZATION OF THE ALARA PRINCIPLE FOR THE MANAGEMENT AND
ELIMINATION OF VERY LOW LEVEL RADIOACTIVE WASTE**

The management of low level solid radioactive waste, as proposed by the National Institutions, cannot be applied to waste produced in a University environment. The report from the Université Catholique de Louvain (UCL) states the reasons and the procedure which has been set up by the radioprotection department. It describes the storage facilities and details the quality control tests carried out during the elimination process. The report outlines the difficulties encountered by the radioprotection departments due to the absence of normes for the disposal of solid radioactive waste.

INTRODUCCIION

Le problème de la gestion des déchets radioactifs est devenu l'un des thèmes majeurs de discussion et de controverse en matière de radioprotection. Il est toutefois internationalement admis par les producteurs de déchets et par les Organismes Nationaux, de classifier ceux-ci en 3 grandes catégories : haute, moyenne et faible activité. Il est bien évident que chaque catégorie implique un mode de gestion adapté. En Belgique, une politique globale et cohérente en la matière, a été mise en place à l'échelon national par l'ONDRAF (Organisme National des Déchets Radioactifs et des Matières Fissiles)

La catégorie des déchets de faible activité comprend non seulement, des déchets provenant de l'énergie électronucléaire, mais également, de laboratoires de recherches universitaires, d'hôpitaux (thérapie) ou de laboratoires d'analyses médicales (diagnostic), déchets que l'on peut qualifier de "très faible activité". Le Service de Radioprotection de l'Université Catholique de Louvain (UCL) a estimé, que l'assimilation de ce dernier type à la catégorie des faiblement radioactifs et à son mode de gestion, ne pouvait se justifier tant pour des raisons scientifiques que pour des raisons économiques.

Il paraissait en effet irrationnel de devoir enfouir, dans des installations de stockage définitif, des radioisotopes de courte demi-vie physique (de l'ordre de quelques heures par exemple). De plus, la relation inversement proportionnelle entre l'activité présente et le volume des déchets produits, aurait impliqué des coûts de traitement considérables et difficilement supportables par les petits producteurs. C'est pourquoi il a été décidé, en concertation avec l'ONDRAF, de développer un programme de gestion spécifique à ces déchets solides de très faible activité.

GESTION DES DECHETS A L'UCL

Objectif

Le faible niveau d'activité ainsi que la faible radiotoxicité des isotopes utilisés au sein des installations de l'UCL, ne doivent pas faire perdre de vue, au radioprotecteur, que le but qu'il poursuit est toujours, même dans ce cas favorable, de limiter au maximum les doses d'irradiation délivrées lors des manipulations, du stockage et de l'élimination de ces déchets, ceci afin de minimiser l'impact radiologique sur le travailleur et son environnement.

Principe de base

Le principe fondamental consiste à isoler les déchets dans des installations appropriées jusqu'à disparition, par décroissance radioactive, d'une quantité suffisante de radionucléides pour que le risque potentiel résiduel, lié à l'élimination par incinération, soit acceptable. La Législation Belge impose, en effet, que tout déchet potentiellement contaminé par des agents mutagènes, cancérigènes, tératogènes, bactériologiques, etc. doive, en finalité, être incinéré.

Dispositions pratiques

Pour mener à bien une bonne gestion de déchets, il importe tout d'abord, d'avoir une bonne connaissance de ce que l'on manipule, c'est-à-dire de la nature et des niveaux de radioactivité des isotopes utilisés. En pratique, cela impose de subdiviser l'institution en petites entités codifiées en fonction du niveau de risque rencontré. Une centaine d'entités ont ainsi été répertoriées. On y trouve les accélérateurs de particules et laboratoires de chimie nucléaire associés, différents laboratoires de recherche en agronomie, en biologie et en médecine, ainsi que différents services hospitaliers. Une bonne connaissance des isotopes et activités manipulés impose une centralisation de la réception des colis radioactifs suivie, après contrôle et enregistrement, d'une redistribution aux entités concernées. Outre les installations typiquement universitaires, une série de cliniques et laboratoires d'analyses biologiques bénéficient également de cette gestion des déchets.

La collecte des déchets dans une unité codifiée est effectuée "par badge" c'est-à-dire, l'ensemble des déchets accumulés depuis le dernier enlèvement. Chaque emballage du lot est identifié pour permettre la traçabilité jusqu'à l'élimination. Les lots de déchets sont alors orientés en fonction de leur contenu. Les émetteurs gamma de demi-vie supérieure à 1 an sont systématiquement évacués vers les installations de l'ONDRAF. Les autres radioisotopes sont entreposés, toujours par lot, dans des conteneurs mobiles de 2 m³, eux-mêmes numérotés.

Parallèlement à cette entrée en stock, les caractéristiques relatives à ce lot sont encodées dans une base de données.

- Il s'agit de :
- numéro du lot (badge),
 - date d'entrée,
 - code de l'entité d'origine,
 - numéro du local et du conteneur de stockage,
 - caractéristiques du badge:
 - type d'emballage,
 - nature isotopique,
 - activité par isotope,*

* L'activité prise en compte est l'activité livrée à l'entité depuis la dernière collecte.

A tout moment, le gestionnaire peut obtenir la liste des déchets pouvant être incinérés. Le logiciel effectue ses calculs en se basant sur les valeurs de la base de données, sur les caractéristiques de l'incinérateur (masse journalière de cendres et volume de gaz produits journalièrement) ainsi que sur les tables de demi-vie physique, les limites dérivées de rejet gazeux et une valeur d'activité spécifique maximum fixée dans les cendres.

LOCAUX DE STOCKAGE

Les locaux de stockage situés dans la "zone nucléaire" de l'Université (accélérateurs, irradiateurs, etc...) sont construits en béton et enfouis sous le sol, au-dessus de la nappe phréatique. Les déchets sont ainsi bien isolés de l'environnement, ce qui entraîne un risque quasi nul pour la population et le personnel. Chaque local, d'une capacité approximative de 300 m³ possède un sol imperméable (résine époxy) en pente douce, permettant ainsi de recueillir dans une citerne les eaux d'infiltration ou les liquides provenant d'éventuels conteneurs endommagés. Etant donné le risque non négligeable d'inflammabilité des déchets (matières plastique, papier, solvants organiques...) un double circuit de détection d'incendie et d'extinction automatique au halon est installé. Un système d'extraction d'air fonctionne en continu, est raccordé à la cheminée de 25 m. du bâtiment et est asservi à la détection incendie. Enfin, un sarcophage de 2m³, dans un coin du local permet le stockage des sources irradiantes.

CONTROLE DE QUALITE

Différentes procédures ont été développées afin d'optimiser la gestion des déchets tout au long de leur cheminement. Des spécifications propres à chaque étape ont été établies. Une formation préalable des producteurs de déchets est assurée par le Service de Radioprotection.

Production

Chaque entité est tenue de veiller à :

- un conditionnement sélectif dans les emballages agréés,
- un étiquetage élémentaire de l'emballage (date, isotope et code de l'entité).

Collecte et transport

Les deux fonctions sont réalisées par le Service de Radioprotection. Lors de la prise en charge, les contrôles suivants sont effectués conjointement par le producteur et le transporteur :

- vérification du conditionnement,
- vérification de l'étiquetage,
- enregistrement du nombre de colis.

Le transport vers les installations de tri et de stockage est effectué dans des conteneurs de transport agréés, par véhicule dûment autorisé.

Tri et mise en stock

Grâce à la gestion informatisée des colis radioactifs, une analyse critique des données fournies par le producteur peut être effectuée lors de la réception des déchets. Une rapide mesure physique permet de s'assurer que le type de rayonnement émis concorde avec l'analyse théorique.

Stockage et élimination

Un contrôle visuel régulier permet de s'assurer de l'état des emballages durant la décroissance. Lors du retrait d'un lot pour élimination, différents aspects sont examinés:

- conformité de la constitution du lot avec les valeurs de la base de données,
- contrôle de la concordance du niveau d'activité résiduelle mesuré avec le niveau théorique calculé.

Incinération

En fonction de la nature et de la forme chimique du radioisotope, l'activité résiduelle peut se retrouver dans les gaz brûlés ou dans les cendres. Un contrôle radiologique des gaz rejetés est réalisé par analyse du condensat du barbotage effectué sur les gaz prélevés dans la cheminée. Actuellement, les différents colis du lot sont répartis sur l'ensemble des déchets incinérés durant la journée pour éviter tout effet de pointe. L'installation d'un rideau d'eau épurateur de fumée supprimera ce risque et permettra, d'ici peu, d'estimer le niveau de radioactivité présent dans les gaz à partir de l'analyse de cette eau.

Un contrôle des cendres est réalisé quotidiennement. Il a pour but de:

- contrôler en finalité l'efficacité des procédures,
- s'assurer de la non-contamination de l'incinérateur par des "déchets radioactifs pirates".

Le contrôle des gaz et des cendres permet, de fournir à l'organisme compétent, toutes les données lui permettant d'assurer son rôle de contrôle.

CONCLUSIONS

L'assimilation des déchets solides de très faible activité, aux déchets de faible activité, n'est pas rationnelle. Toutefois, si l'on veut respecter le principe ALARA en matière de gestion, il est nécessaire de disposer d'une infrastructure minimale:

- véhicule de transport autorisé,
- conteneurs de transport agrés,
- locaux de stockage équipés,
- incinérateur propre,
- chaînes de comptages bas-niveaux,
- personnel compétent.

Un centre universitaire disposant de ces facilités peut ainsi assumer efficacement la gestion de ses propres déchets. De plus, sous le contrôle de l'Organisme Public compétent, il peut également remplir sa mission de service au public, en assurant la gestion des déchets des tout petits producteurs (médecins privés, cliniques, laboratoires d'analyses). Grâce à la gestion informatisée et aux différents contrôles de qualité, le respect des normes de rejet gazeux peut être assuré et l'implication sur l'environnement quantifiée. La position du gestionnaire reste toutefois inconfortable en ce sens qu'il est réduit, en l'absence de législation précise, à devoir estimer lui-même le niveau maximum qu'il tolèrera dans les cendres produites par la combustion des déchets.

**COMMENT ELECTRICITE DE FRANCE
A DIVISE PAR DEUX EN CINQ ANS
LE VOLUME ANNUEL DE DECHETS RADIOACTIFS
PRODUITS DANS SES CENTRALES**

J. HERISSON

Electricité de France
Service de la Production Thermique
Paris - La Défense

**HOW EDF, IN FIVE YEARS TIME,
HAS HALVED THE ANNUAL VOLUME OF RADIOACTIVE WASTES
PRODUCED IN ITS POWER PLANTS**

The production of radioactive wastes, expressed in volume of packs of wastes, ready for final storage, from the EDF nuclear plant units, has gone from 380 cubic meters per plant unit per year in 1985 to 180 cubic meters per plant unit per year in 1990.

Other than the technical aspects, this performance has been due to measures taken by EDF in the area of management. These measures are to be supplemented in the medium term by the industrial implementation of centralized treatment techniques such as fusion and incineration.

La production de déchets radioactifs, exprimée en volume de colis de déchets prêt au stockage définitif, des tranches nucléaires d'Electricité de France est passée de 380 mètres cubes par tranche et par an en 1985 à 180 mètres cubes par tranche et par an en 1990. Le progrès est particulièrement significatif pour les déchets de procédés (résines, concentrats, filtres, générés par le traitement des circuits liquides et gazeux), pour lesquels la production annuelle moyenne est passée en cinq ans de $240\text{m}^3/\text{tr}/\text{an}$ à $85\text{m}^3/\text{tr}/\text{an}$.

La production de déchets technologiques (vinyle, papiers, métaux, gravats...) générés par les opérations de maintenance est passée, pendant la même période de $140\text{m}^3/\text{tr}/\text{an}$ à $95\text{m}^3/\text{tr}/\text{an}$ (malgré plusieurs visites décennales).

Cette performance se situe dans un contexte caractérisé par deux données :

- l'envoi systématique (pas d'entreposage sur site) au centre de stockage de l'Agence Nationale pour la gestion des Déchets Radioactifs (l'ANDRA), des déchets produits en exploitation, coûteux mais sûr et incitatif à la réduction de volume,
- l'absence de seuil réglementaire "de minimis" qui conduit à considérer, de manière conservatoire, comme radioactifs certains déchets de très faible activité.

Elle repose, au delà des aspects techniques, sur les dispositions prises en matière de management à EDF. Ces dispositions seront complétées à terme par la mise en place de techniques centralisées de traitement telles que la fusion et l'incinération.

1 - DISPOSITIONS PRISES EN MATIERE DE MANAGEMENT

Les dispositions prises en matière de management autour de la gestion des déchets, s'articulent principalement autour de deux axes, à savoir "responsabilisation" et "organisation".

La responsabilisation :

Elle intègre

- la sûreté qui veut que la production de déchets soit limitée autant qu'il est possible,
- les coûts qui vont dans le même sens que la proposition précédente.

Cette responsabilisation concerne toute la ligne hiérarchique :

- le Responsable national du parc nucléaire qui impulse la politique notamment dans ce domaine et la traduit en objectif dans les contrats de gestion des sites. Ces objectifs sont suivis à l'aide d'indicateurs conçus à l'échelon national.
- le Chef de site qui représente l'exploitant nucléaire et est à ce titre responsable de la production de déchets,
- les Chefs de Service concernés (Service conduite pour l'optimisation des moyens d'exploitation et de traitement, Service maintenance pour la production des déchets technologiques liés aux interventions),
- les Chefs de travaux sur le terrain (préparation et organisation des chantiers, rédaction de modes opératoires et tri à la source des déchets solides).

L'organisation :

Les mesures organisationnelles s'exercent à deux niveaux :

Au niveau local,

Par la mise en place de structures opérationnelles de gestion des déchets et d'optimisation des moyens de traitement, assurant coordination et sensibilisation (par le biais d'indicateurs) de tous les services concernés.

Au niveau du Parc Nucléaire

Par l'existence de services fonctionnels chargés :

- de définir la politique, d'assurer sa promotion et de faire vivre le retour d'expérience,
- de contrôler la mise en oeuvre des politiques et de détecter les "bonnes pratiques".

Ces services orchestrent un retour d'expérience efficace qui a pour objet :

- d'éviter que les "mauvaises pratiques" ou les incidents constatés sur un site ne se reproduisent sur un autre site,
- d'assurer que les "bonnes pratiques" mises en oeuvre à tel ou tel endroit profitent à tous les sites du parc et aux tranches futures.

2 - DISPOSITIONS PRISES EN MATIERE DE TECHNIQUE

En ce qui concerne les déchets de procédés, les progrès significatifs traduisent une bonne maîtrise de l'exploitation des installations et notamment de la gestion et du traitement des effluents liquides. Parmi les pratiques déterminantes pour l'amélioration de ce poste, peuvent être cités :

- la réduction de la production des effluents liquides par une organisation rigoureuse des mouvements d'eau (vidange et remplissage des circuits, contrôle des fuites) et l'optimisation des moyens de leur traitement par une utilisation judicieuse des évaporateurs et des déminéraliseurs,
- l'optimisation de l'exploitation des déminéraliseurs en particulier sur les circuits de contrôle volumétrique et chimique des circuits principaux,
- l'optimisation du remplissage des conteneurs, notamment par le regroupement des filtres,
- le démantèlement et le compactage des filtres de ventilation,
- le rejet des concentrats après décroissance (solution qui dépend des capacités de stockage et des radioéléments rencontrés).

En ce qui concerne les déchets technologiques, l'amélioration de ce poste "déchets technologiques" passe par une double action : réduction des volumes à la source et tri efficace permettant une optimisation de la production et des conditionnements. Les bonnes pratiques identifiées en la matière sont notamment :

- les mesures limitant l'introduction, en zone, de matériaux contaminables (emballages, palettes, bois, etc...),
- la distribution limitée au strict nécessaire des matériaux consommables entrant en zone contrôlée (produits chimiques, de nettoyage, vinyle, etc...),
- l'analyse relative à la présentation des interventions (promotion du confinement dynamique, utilisation de sas décontaminables et recyclables, etc...) et au traitement du déchet résultant (rabotage du bois contaminé, dégainage des câbles, etc...).

3 - LES DEVELOPPEMENTS EN COURS A EDF SUR LE CONDITIONNEMENT DES DECHETS

La recherche permanente de progrès en matière de réduction de volume de déchets radioactifs solides va conduire à terme à des réalisations industrielles de traitement : il s'agit d'une installation de fusion des ferrailles contaminées et d'une installation d'incinération des déchets technologiques de faible activité.

- La fusion des ferrailles contaminées

L'entretien courant des centrales nucléaires produit de l'ordre de 500 t/an d'aciers plus ou moins contaminés. Les opérations particulières que sont les grosses réparations et les opérations de démantèlement généreront des tonnages supplémentaires.

Cette solution passera par une installation industrielle de fusion des ferrailles qui combinera un processus de décontamination surfacique avec un four de fusion proprement dit. Seront alors élaborés différents produits en fonction de l'activité croissante des ferrailles traitées.

Ce projet industriel est un élément du dispositif nécessaire à la maîtrise des déchets, tant au plan économique qu'à celui de la prévention de la dissémination de la contamination.

- L'incinération des déchets de faible activité dits "technologiques"

Actuellement, ces déchets sont évacués des centrales en fûts métalliques et livrés sur les centres de stockage où ils sont conditionnés de manière définitive par compactage pour réduire leur volume et immobilisation dans un liant hydraulique.

Ce procédé de compactage, qui a fait ses preuves depuis de nombreuses années, peut être valablement mis en concurrence tant sur les plans de la qualité du conditionnement que sur le plan économique avec un procédé d'incinération approprié. En effet, l'incinération a pour avantages essentiels :

- de réduire bien davantage le volume des déchets à stocker et donc, pour autant que la capacité radiologique du centre de stockage le permette, de prolonger la durée de vie de celui-ci,
- de transformer les déchets bruts, (constitués en faible proportion de matières organiques), en déchets secondaires minéraux, stables et homogènes.

Le procédé retenu à l'issue d'études et d'essais sur un prototype industriel met en oeuvre une torche à plasma.

4 - CONCLUSION

Les dispositions prises par EDF, tant en management qu'en maîtrise des productions à la source, prolongées par la mise en service à terme d'installations centralisées de fusion et d'incinération permettront d'aboutir à une réduction de volume aussi performante que peuvent le permettre les techniques actuellement industriellement disponibles, et ceci dans un cadre où la qualité et la sûreté des conditionnements des déchets sont parfaitement maîtrisées.

Si les déchets radioactifs sont un des problèmes de société placés en première ligne dans les soucis des opinions publiques, le traitement des déchets industriels en général est une activité en plein développement soumise aux exigences liées à la protection de l'environnement. La démarche et les moyens mis au point pour le traitement des déchets radioactifs peuvent être facilement transposés à celui des déchets industriels pour lesquels des objectifs analogues de réduction importante de volume ou de non dissémination de produits nocifs sont recherchés.

**ASPECTS "DE MINIMIS" EXEMPLES DE
DIFFICULTES RECENTES RENCONTREES DANS LES
CENTRALES NUCLEAIRES D'EDF
POUR LA GESTION DES DECHETS TRES
FAIBLEMENT RADIOACTIFS**

Texte rédigé par Pierre BOUSSARD
et présenté par Jean-Marc DUCOULOMBIER

Electricité de France
Service de la Production Thermique
D.S.R.E. - Saint-Denis

**CLEARANCE LEVEL (DE MINIMIS) : EXEMPLES OF
DIFFICULTIES MET IN THE NUCLEAR POWER PLANTS OF
EDF ABOUT THE VERY LOW LEVEL ACTIVE WASTE
MANAGEMENT**

ABSTRACT : The absence of a clear reglementation concerning very low radioactive waste management has led EDF to harmonise its internal practices. However plant operators are still confronted with many difficulties for :

- very low radioactive waste which have really been contaminated
- very low radioactive waste whose radioactivity is not due to on a site nuclear practices (natural radioactivity or off-site artificial radioactivity)
- waste which is suspected to be contaminated simply because it has transited through a nuclear plant even outside of all controlled areas.

INTRODUCTION

La réglementation française ne fixe pas de seuil au dessous duquel un corps n'est pas considéré comme radioactif et peut être remis dans le domaine public. La réglementation sur les matières radioactives ne s'applique qu'à partir de 74 ou 100 Bq/g. On pourrait en déduire que, à contrario, au-dessous de ces valeurs un déchet n'est pas radioactif. ELECTRICITE DE FRANCE est en pratique confronté à cette difficulté depuis de nombreuses années.

GESTION DES DECHETS FAIBLEMENT ACTIFS A ELECTRICITE DE FRANCE

Les règles pratiques internes appliquées dans le Service de la Production Thermique d'ELECTRICITE DE FRANCE dérivent du principe de non contact avec une source contaminante ou activante. Elles sont définies par deux documents :

- Une Instruction qui fixe des activités volumiques (3,7 Bq/l en gamma total) en dessous desquelles un déchet peut être considéré comme n'ayant pas eu de contact avec un fluide contaminant et géré comme un déchet classique. Ces déchets sont essentiellement des filtres, résines, huiles et solvants.

- Un Guide Pratique de Radioprotection qui fixe des activités surfaciques (3,7 Bq/cm² pour les émetteurs bêta gamma) en dessous desquelles un matériau ou un outillage sortant de zone contrôlée est réputé non contaminé et géré d'une manière classique.

Ces deux documents servent de fils directeurs pour les centrales, mais de plus, la balise de sortie de site dont le seuil d'alarme est réglé entre 3 et 4 fois le bruit de fond ambiant, sanctionne toute erreur dans l'estimation de l'activité d'un matériau pouvant être rejeté en décharge contrôlée ou recyclé.

DECHETS DE FAIBLE ACTIVITE ARTIFICIELLE

Résidus liquides de lessivage des GV

Les opérations de nettoyage chimique des générateurs de vapeur des tranches REP engendrent des volumes de résidus liquides importants, environ 2000 m³ par GV. Ces volumes, composés d'un mélange d'acide gluconique, d'ammoniaque et d'acide citrique sont peu actifs. Les radioéléments présents, Cobalt 58 et 60, Césium 134 et 137 et Manganèse 54 proviennent des dépôts de magnétite, cuivre et oxyde de zinc retirés des générateurs de vapeur par le nettoyage chimique. Ces volumes peuvent être éliminés par incinération.

Les activités mesurées, pour les 4 GV de la tranche 1 de Nogent, sont :

- 1000 m³ d'activité gamma total < 10 Bq/l
- 800 m³ d'activité gamma total égale à 30 Bq/l.

Les 1000 m³ d'activité inférieure à 10 Bq/l ont été incinérés en 1989 après accord du SCPRI.

Pour les 800 m³ restant, d'activité gamma total égale à 30 Bq/l, un dossier d'impact sur l'environnement a été établi par le CEA/IPSN pour l'incinération de ces résidus. Le SCPRI a donné son accord de principe sous réserve que leur activité soit inférieure à 100 Bq/L et que les sociétés prestataires (Usine d'Incinération et Centre d'Enfouissement) aient reçu l'autorisation préalable des DRIR dont elles dépendent sur le plan réglementaire en tant qu'ICPE. Ces 800 m³ n'ont pu être incinérés faute d'obtenir l'accord de la DRIRE. Ils sont stockés actuellement dans des wagons sur le site de la centrale.

Calorifuge de CHINON A2

L'opération de décalorifugeage des échangeurs et soufflantes de CHINON A2 s'est étendue de Mars 1988 à Janvier 1989. Le calorifuge non activé a été mis en sacs et trié suivant des critères fournis par le SCPRI dans son télex donnant l'accord de principe à savoir :

- Absence d'émetteurs alpha
- Activité < 1 Bq/g
- Contrôle d'activité de la totalité du calorifuge
- Contrôle de débit de dose de chaque chargement
- Tenue à jour d'un registre

L'activité moyenne qui provient du cobalt 60 (naturelle + artificielle) du calorifuge envoyé à la décharge était de 0,3 Bq/g et l'activité totale de 16,8 E6 Bq (0,5 mCi).

56 tonnes de calorifuge ont été évacuées dans une décharge d'ANGERS, le calorifuge dont l'activité est comprise entre 1 et 2,5 Bq/g a été entreposé pour décroissance et le calorifuge dont l'activité est > 2,5 Bq/g a été expédié au SSM après compactage.

Ferrailles d'exploitation

Les déchets issus des zones contrôlées, pièces métalliques venant des circuits en contact avec le fluide primaire ou outillage divers, sont contrôlés et triés ; ceux qui n'ont pas été en contact avec une source contaminante ou activante sont évacués vers des ferrailleurs ; ceux dont la contamination est supérieure à 3,7 Bq/cm² et dont l'activité est inférieure à 100 Bq/g sont stockés sur parc.

Actuellement et pour les 10 années à venir, les déchets métalliques d'activité comprise entre 1 et 100 Bq/g, produits par les centrales REP représentent 300 tonnes d'inox et 250 tonnes de ferritiques environ.

Ferrailles de démantèlement

Les ferrailles de démantèlement pour les 10 années à venir, d'activité inférieure ou égale à 1 Bq/g représentent 7500 tonnes. Les radionucléides présents dans ces ferrailles sont essentiellement, le cobalt 60 pour 97 à 98 %, le manganèse 54 pour 1 à 1,5 % et le césium 137 pour 0,5 à 3 %.

DECHETS DE FAIBLE ACTIVITE ARTIFICIELLE NON DUE A L'EXPLOITATION DES REP

Filtres de dépoussiérage

Les filtres de dépoussiérage de l'air extérieur des ventilations déclenchaient les balises de sortie de site après l'accident de Tchernobyl et ont dû être conditionnés en fût métallique et expédiés à l'ANDRA comme déchets radioactifs.

Détecteurs incendie

Les détecteurs incendie, comprenant des sources d'américium, issus des locaux des centrales sont également conditionnés en fût métallique comme déchets radioactifs (les pratiques sont différentes suivant les entreprises).

DECHETS DE FAIBLE ACTIVITE NATURELLE

Produits de sablage radioactif naturellement

L'utilisation de sable à base de scories de charbon pour la remise en état des portiques du bâtiment réacteur a du être proscrite, car l'activité naturelle présente, de 0,8 Bq/g en gamma totale (hors potassium), déclenchait la balise à l'entrée du site.

Chambres de coupure des disjoncteurs de Chinon A2

Au cours des travaux de démantèlement des locaux électriques de Chinon A2, lors du contrôle, avant la sortie de site, du camion chargé des armoires électriques destinées à un ferrailleur, on a constaté une certaine radioactivité des chambres de coupure en céramique des disjoncteurs (Ra 226 1,50 Bq/g, Th 228 0,25 Bq/g, Ac 228 0,28 Bq/g).

Ces chambres ont été entreposées sur site.

CONCLUSION

En définitive, le Service de la Production Thermique d'ELECTRICITE de FRANCE a fait quelques tentatives pour définir une politique interne pour des déchets bien spécifiques afin de sortir de situations qui se bloquaient ; mais cette politique s'avère de plus en plus inadaptée, notamment pour résoudre les problèmes posés par l'élimination de déchets produits en grande quantité et présentant une radioactivité très faible, voire proche ou inférieure à la radioactivité naturelle et pour définir un critère de tri sur les déchets dits douteux.

Il faut noter toutefois qu'ELECTRICITE de FRANCE a toujours fait la distinction entre les effluents radioactifs qui sont dilués au moment des rejets autorisés par la réglementation et les déchets faiblement radioactifs (résidus liquides ou autres) dont elle s'interdit toute dilution.

Actuellement la situation s'éternise (les ferrailles de Chinon A3 sont sur parc depuis plus de 20 ans) et l'absence de texte réglementaire se traduit par une production injustifiée de déchets dits radioactifs puisqu'on enfûte des matériaux ou des objets considérés comme contaminés par le seul fait qu'ils sont entrés dans une centrale nucléaire (cas des filtres de dépoussiérage de l'air extérieur après l'accident de Tchernobyl). Outre un coût important du conditionnement et du stockage, ceci conduit à encombrer inutilement le centre de l'ANDRA à un moment où le public est très sensibilisé à cette phase du cycle nucléaire.

Il nous paraît donc indispensable et urgent, dans le prolongement des recommandations de l'AIEA et de la CEE, que la réglementation française évolue vers la définition d'un seuil d'exemption en dessous duquel un déchet pourra être considéré comme "non radioactif". Une valeur homogène avec la réglementation sur les matières radioactives nous paraîtrait satisfaisante.

ELECTRICITE de FRANCE est bien consciente que l'adoption d'un seuil d'exemption entraînera une modification de sa politique de gestion des déchets faiblement radioactif, en particulier il paraît évident que les moyens de décontamination, de stockage pour décroissance et de mesure d'activité devront être développés d'une façon importante. ELECTRICITE de FRANCE s'y tient prête et orientera son action dans ce sens.

MOYENS INFORMATIQUES MIS EN OEUVRE A EDF POUR GERER RATIONNELLEMENT LES
DECHETS RADIOACTIFS

M.COMMUNAUX / J.HERISSON

Electricité de France
Service de la Production Thermique
D.S.R.E. - St DENIS

Abstract :

Since December 31, 1990, the management of the nuclear waste packs for all the power stations has been computerized, utilizing the DRA module of the Thermal Production Department data processing master plan.

So now EDF has a software package which centralizes all the data, enabling it to declare the characteristics of the nuclear waste packs which are to be stored at the sites operated by the National Radioactive Waste Management Agency (ANDRA).

Among other uses, this application will make it possible for EDF, by real time data exchange with ANDRA, to constitute an inventory of validated, shippable packs. It also constitutes a data base for all the wastes produced at the various sites.

Depuis le 31 décembre 1990, la gestion des colis de déchets nucléaires de toutes les centrales est assurée par informatique, grâce au module DRA du schéma directeur informatique du Service de la Production Thermique. EDF dispose ainsi d'un logiciel qui centralise toutes les données permettant la déclaration des caractéristiques des colis de déchets nucléaires destinés à être stockés sur les sites exploités par l'Agence Nationale de gestion des Déchets Radioactifs (ANDRA).

Cet applicatif permet, entre autre, à EDF de constituer, par échange de données en temps réel avec ANDRA, un stock de colis validés et expédiables. Il constitue également une base de données de tous les déchets produits sur les différents sites.

Cet applicatif a été développé pour répondre aux demandes suivantes:

- Offrir aux producteurs de déchets radioactifs un outil qui permet une gestion complète de toutes les caractéristiques et de tous les matériels nécessaires au bon conditionnement de leurs déchets.
- Assurer la traçabilité et la sûreté des informations et permettre une transmission de ces informations en automatique et en temps réel entre les producteurs et l'ANDRA.
- Offrir aux services centraux d'EDF un outil d'exploitation et de statistiques permettant un retour d'expérience sur l'ensemble de la production nationale (base de données unique, centralisée).
- Intégrer l'applicatif dans les produits du schéma directeur informatique garantissant ainsi sa maintenance et son évolution.

OUTIL D'EXPLOITATION

L'applicatif DRA est basé sur un gestionnaire de base de données fonctionnant dans un environnement gros système IBM. Sur chaque site producteur de déchets, un réseau local de micro-ordinateurs de type IBM PC dialogue avec un ordinateur central IBM situé à Paris par l'intermédiaire d'un réseau privé EDF basé sur TRANSPAC.

L'applicatif DRA permet la gestion et la traçabilité des différentes données et caractéristiques relatives aux colis de déchets radioactifs depuis le déchet proprement dit, son conditionnement et jusqu'à l'expédition des colis sur les centres de stockage. Il inclut le suivi des conteneurs de conditionnement, des bâches résines et concentrats et des zones de stockages sur site.

Ces données sont saisies et contrôlées par un opérateur, vérifiées par l'applicatif et validées par un vérificateur.

Fonctionnalités :

Réception des conteneurs.

Par lecture codes barres ou par transfert de fichier, les conteneurs livrés sur site sont vérifiés par comparaison avec une liste de référence (utilisation de Terminaux de Saisie Portable équipés de lecteurs laser.) puis transférés dans DRA. L'applicatif assure l'unicité des numéros de conteneurs pour l'ensemble du parc nucléaire.

Gestion documentaire.

Les différentes fiches de saisie papier, fiches suiveuses de collecte de déchets et fiches d'identification de colis, qui doivent encore être utilisées, sont éditées par DRA.

Gestion des déchets.

Les caractéristiques des déchets produits sont saisies sur DRA (fiches suiveuses), les données sont vérifiées par rapport aux différents descriptifs de procédés puis mémorisées (base de données).

Gestion des bâches.

Les caractéristiques des différentes bâches de stockage ou de transport (niveau, activité ...) sont calculées automatiquement en fonction des paramètres des déchets transférés dans ces bâches par l'intermédiaire des données présentes sur les fiches suiveuses puis elles sont mémorisées par cycle d'utilisation des bâches (base de données).

Gestion des spectres.

Les caractéristiques des différents spectres utilisés pour définir les particularités radiologiques des déchets sont saisies, vérifiées et mémorisées (base de données); DRA garantit l'unicité des identifiants des spectres.

Gestion des colis.

Les caractéristiques des colis produits sont saisies sur DRA (fiches d'identification), les données sont vérifiées par rapport aux différents descriptifs de procédés puis mémorisées (base de données); DRA assure la gestion du stock des conteneurs (conteneurs vides, colis en cours, colis expédiables, colis expédiés).

Déclaration à l'ANDRA.

DRA assure la liaison entre les informations déchets, spectres et colis pour calculer les caractéristiques qui sont envoyées automatiquement par l'applicatif vers l'ordinateur de l'ANDRA qui les traite.

La réponse de l'ANDRA, automatique également (temps de réponse de l'ANDRA, traitement compris, inférieur à 15 mn pour les informations de 200 colis) est gérée par DRA, cette réponse est soit une validation (colis expédiable) soit un message d'erreur indiquant la cause du refus de validation de ces caractéristiques.

Expéditions.

DRA assure une aide à la création d'expédition, les opérateurs, sur leur poste de travail, chargent des colis (expédiables uniquement) dans des transconteneurs, ces transconteneurs sont chargés sur des camions ou wagons, qui sont regroupés en expéditions.

Les caractéristiques de l'expédition sont établies et contrôlées automatiquement au fur et à mesure de la constitution.

Les caractéristiques de l'expédition sont envoyées par transfert de données informatiques à l'ordinateur de l'ANDRA de la même façon que les données colis.

Le dossier papier d'expédition est édité automatiquement par DRA et placé dans les différents camions ou wagons (respect de la réglementation des transports).

Gestion géographique.

Les zones de stockage des centrales sont gérées. Le nombre de colis, le type de colis, l'expédiabilité d'une zone entière, le poids et l'activité total des colis de chaque zone sont suivis.

Éditions.

La base de données de DRA (déchets, spectres, colis, expéditions) procure un outil de statistique qui fournit des éditions locales et nationales.

INTEGRATION COMPLETE DANS LES PRODUITS DU SCHEMA DIRECTEUR

Le Schéma Directeur Informatique du Service de la Production Thermique a pour objectif d'offrir aux exploitants des centrales nucléaires des outils informatiques dans différents domaines (maintenance, sûreté, formation, gestion ...) qui présentent tous des caractéristiques homogènes.

Ces produits ont été développés, testés, documentés, mis en service, exploités suivant des normes strictes et communes.

Ces normes garantissent, en particulier, la maintenance à long terme, l'adaptation rapide du personnel d'une application à une autre, l'utilisation d'un matériel commun à toutes les applications.

SURETE ET TRACABILITE DES INFORMATIONS

Sûreté et sécurité informatique

L'application DRA utilise le gestionnaire de base de données CRADLE en environnement CICS IBM ce qui implique l'utilisation des sécurités liées aux applications tournant sur gros systèmes et exploitées dans des centres de calcul par du personnel spécialisé.

La sécurité des accès est garantie à plusieurs niveaux :

- Chaque poste de travail est identifié de façon unique.
- Seuls les postes de travail dont les identifiants ont été déclarés par les exploitants du centre de calcul accèdent à l'applicatif.
- L'autorisation d'accès à l'applicatif est associé à un "user" personnel créé par un administrateur national.
- L'utilisation des fonctionnalités est liée à des habilitations affectées à chaque "user" par un gestionnaire local.
- Chaque "user" est associé à un mot de passe modifiable par son propriétaire.

Tracabilité et sûreté des informations.

Les informations sont "en cascades" (ex: Résines -> Bâche -> colis -> expédition), les liens dans les sens amont-aval et aval-amont sont systématiquement conservés.

Ceci permet, par exemple, de retrouver les caractéristiques de chaque transfert de résine ou de chaque colis conditionné durant un cycle d'utilisation d'une bâche donnée.

La suppression ou la modification de paramètres n'est autorisée que pour certaines habilitations et uniquement si cette modification n'a pas d'impact sur une information en aval qui peut être verrouillée (cas des colis expédiés sur un site de stockage).

Le "user" responsable de la dernière modification ou création d'information est mémorisé.

Toute création ou modification d'information est soumise à approbation d'un vérificateur.

BILAN DE FONCTIONNEMENT

Cet applicatif est en exploitation sur tous les sites producteurs depuis le 01 janvier 1991.

Au terme de dix mois de fonctionnement DRA a assuré la gestion de plus de quarante cinq mille colis, permet la constitution de quatre cent cinquante expéditions contenant plus de vingt et un mille colis.

La mise en service de DRA a constitué, pour EDF, une étape déterminante pour conforter la totale maîtrise de la sûreté et de la qualité de sa production de déchets radioactifs.

PROBLEMES POSES PAR LA COLLECTE ET LA PRISE EN CHARGE DU RADIUM

Philippe KISSEL , Patrice CHARBONNEAU

C.E.A./ Institut de Protection et de Sûreté Nucléaire

Département de Protection de l'Environnement et des Installations

Office d'Assistance en Radioprotection (OAR)

92265 Fontenay aux Roses Cedex . France

PROBLEMS RAISED BY RADIUM COLLECTION AND FINAL PROCESSING

Radium, in its different physico-chemical states and in source form, whether sealed or not, has been the first radionuclide to be used by industry and medicine.

Progressively given up and replaced by other radionuclides providing a more attractive efficiency/safety ratio, waste of radium and compounds are currently often stored in totally unsuitable places.

Considering the 1622 years radioactive half-life of radium, the radiological hazards bound to that natural radionuclide are important enough to start urgently the collection of this type of waste by a specialized organism.

The problems raised by radium collection and final processing, including the on site conditioning and the conveying to the selected storage places, are the subject of the present paper.

1 - INTRODUCTION

Rappelons que le radium, sous différents états physico-chimiques et sous forme de sources, scellées ou non, a été le premier radionuclide utilisé dans les domaines industriel et médical. Progressivement abandonné pour d'autres radionucléides ayant un rapport efficacité/sécurité plus attrayant, le radium et ses différents composés sont actuellement sans emploi et entreposés en des lieux qui ne sont pas toujours adaptés. Compte tenu de sa période radioactive (1622 ans), les risques radiologiques liés à ce radionuclide naturel sont suffisamment importants pour que la prise en charge de ce type de déchets par un organisme compétent et spécialisé, disposant de tous les moyens nécessaires et ayant une structure nationale, soit impérative.

Les problèmes posés par la collecte de ces déchets, incluant le reconditionnement sur le site de leur détention et le transport jusqu'aux lieux d'entreposage ou de traitement adéquat, ont fait, en France, l'objet d'un examen approfondi qui a conduit à une organisation particulière s'intégrant dans l'organisation générale de collecte des autres catégories de déchets radioactifs issus des établissements dits "petits producteurs" : établissements industriels et hospitaliers, d'enseignement et de recherche industrielle ou médicale, et nombre de petites entreprises (fabricants et installateurs de paratonnerres, horlogers,...), de praticiens (médecins,...) ou même de particuliers se retrouvant héritiers de sources de radium.

2 - CONSTITUTION ET SUIVI DU DOSSIER DE PRISE EN CHARGE

Après enregistrement de la demande d'enlèvement établie par le détenteur de radium et ouverture d'un dossier correspondant, la première opération effectuée par l'Office d'Assistance en Radioprotection (OAR) de l'Institut de Protection et de Sécurité Nucléaire (IPSN/CEA) est la vérification des données techniques et administratives portées sur cette demande, ce qui conduit très fréquemment à établir un contact direct avec le détenteur, afin d'obtenir de sa part certains compléments d'information tels que l'identification du fournisseur, la date de la fourniture du radium, la documentation technique d'origine, l'état physico-chimique initial et présent des produits radioactifs, les caractéristiques mécaniques de l'enveloppe des sources et de leur support ou de l'emballage des produits, ... Un examen, sur place, permet de recueillir certaines données techniques, non connues du détenteur, mais considérées comme indispensables en vue d'effectuer une prise en charge du radium qui soit conforme au Règlement de Transport des Matières Dangereuses (RTMD).

Sont notamment effectués dans les locaux du détenteur la caractérisation, par spectrométrie, des radionucléides émetteurs alpha (Ra226, Am241, ...), un contrôle neutronique pour la recherche de sources de radium-béryllium, et le contrôle des équipements ou des lieux du point de vue de la contamination. Accessoirement, des mesures de gaz radon sont effectuées.

Seule la réunion de toutes ces données peut permettre de préparer la stratégie de prise en charge complète et définitive, comprenant toutes les opérations, de l'enlèvement sur place (collecte) au stockage définitif, y compris la fourniture éventuelle d'emballages conformes au Règlement de Transport des Matières Dangereuses et de moyens de manutention appropriés, tels que téléopérateurs mobiles permettant d'effectuer le transfert à distance de sources particulièrement irradiantes.

Dans certains cas, au cours des travaux, des éléments peuvent conduire à prendre des dispositions supplémentaires et onéreuses de sécurité, telles que prise en charge d'autres matières radioactives, décontamination, jugée indispensable, de lieux ou d'équipements présentant un danger immédiat lié à une contamination significative.

Au besoin, une dérogation au Règlement de Transport peut être nécessaire en vue d'effectuer certains transports de radium, car il n'existe toujours pas d'emballage de type B agréé pour le transport de ce radionucléide.

Une fois planifiées les opérations de collecte et autres opérations liées à celles-ci, telles que reconditionnement sur place en emballage de transport et d'entreposage, tous les documents de transport requis sont établis par l'OAR:

- attestation d'expédition de matières radioactives sur la voie publique,
- bordereau de prise en charge chez le détenteur,
- avis de transport au Centre CEA destinataire,
- avis de livraison à l'Unité CEA chargée des premières opérations de prise en charge (entreposage ou traitement)
- avis éventuel de convocation d'une équipe de convoi pour le transport routier.
- au besoin, notification préalable de transport à la Direction de la Défense et de la Sécurité Civile.

3 - OPERATIONS DE COLLECTE ET AUTRES PRESTATIONS ASSOCIEES

Les opérations programmées sur site en vue de reconditionner le radium en emballages transportables sont ensuite réalisées, suivies d'un transport allant de la simple collecte, similaire à celle d'un colis classique de déchets radioactifs, au transport spécial avec convoyage lorsque cela est exigé dans la dérogation ministérielle.

Le radium est ensuite déposé sur une aire OAR d'entreposage de courte durée (<3 mois) ou livré à une Unité C.E.A. se chargeant, soit de son entreposage de moyenne (<5 ans) ou de longue durée (30 ans) en attente de son transfert vers un stockage définitif.

Les éléments de dossier utiles sont remis à l'Unité CEA prenant temporairement en charge le radium et un échange de visas est fait sur des bordereaux de mouvement de matières radioactives .

Une attestation de prise en charge est ensuite adressée à l'ex-détenteur du radium, et un compte - rendu est établi destiné aux différentes Autorités de tutelle ayant à connaître le devenir de toute source radioactive.

Des provisions, destinées à la couverture financière de toutes les opérations dont la réalisation est ultérieurement prévue, notamment celles correspondant au stockage définitif, sont constituées.

4 - ENTREPOSAGES DE COURTE ET MOYENNE DUREES

L'entreposage de courte durée (<3 mois) correspond au nécessaire besoin de transit des colis lors de leur déchargement du véhicule de collecte.

Un tel entreposage, d'une durée maximale de trois mois, a été ouvert par l'OAR pour effectuer certains contrôles d'assurance qualité, notamment en matière de sécurité radiologique, et pour trier les colis en vue de la préparation des chargements destinés aux autres unités du CEA.

L'entreposage de moyenne durée (<5 ans), a pour objet de permettre la constitution de lots de sources radifères de même type, destinés à être, soit traités séparément à des postes de travail particuliers afin d'optimiser les coûts, soit acheminés, après reconditionnement conforme à ses spécifications propres, vers un centre CEA d'entreposage de longue durée.

Un tel entreposage de moyenne durée a ainsi été ouvert à proximité immédiate du poste de traitement des paratonnerres au radium qui, en nombre de sources et en activité globale, pourraient représenter des quantités importantes.

En vue du transport et de l'entreposage du radium, quatre modèles de colis ont été "standardisés" par l'OAR :

le colis "K1" constitué d'une boîte métallique sertie de un litre contenant un petit conteneur de plomb dans lequel est placé le radium ; une gamme de différents modèles de conteneurs de plomb permet d'effectuer le choix le plus approprié en regard de l'activité des sources;

le colis "K2" constitué d'une boîte métallique sertie de deux litres avec conteneur de plomb;

le colis "K20" constitué d'une poubelle étanche alpha de vingt litres, type DTPE A29 de la société "La Calhène", dans laquelle les sources de radium, laissées dans leurs conteneurs d'origine ou replacées en conteneurs appropriés, sont conditionnées dans un mélange, sable sec et grenaille de plomb, dosé pour limiter les niveaux d'irradiation en vue de satisfaire aux normes de transport ; cette poubelle étanche est elle-même calée dans un fût métallique avec couvercle à pattes pouvant être serties;

le colis "K35" constitué d'une poubelle étanche alpha de trente cinq litres, type DTPE de la société "La Calhène", utilisée dans les mêmes conditions que la précédente.

5 - CONDITIONNEMENT POUR L'ENTREPOSAGE LONGUE DUREE

Les spécifications techniques précises relatives au conditionnement du radium en vue de son stockage définitif n'étant pas encore connues, il restera indiqué de conditionner le radium, dès sa prise en charge sur le lieu de détention, de telle sorte que ce premier conditionnement puisse, avec un emballage adéquat étanche au radon, constituer un colis conforme tout à la fois aux règlements de transport (RTMD) et aux spécifications d'entreposage pour une durée de l'ordre de 30 ans.

Un conditionnement étanche pourrait ainsi être réalisé "in situ" avec l'équipement mobile "CORA", qui correspond à un projet élaboré par l'CAR pour la "Collecte du Radium", et qui permettrait la réalisation de colis types K1, K2, K20 ou K35, tels que décrits ci-dessus.

Les spécifications techniques pour l'entreposage CEA de longue durée correspondent à un conditionnement réalisé en fût de 60 litres, placé dans un fût prébétonné de 200 litres; dans un tel emballage peuvent être placés soit "30 colis de type "K1", soit 15 colis de type "K2", soit un colis de type "K20" ou "K35".

6 - RECONDITIONNEMENT FINAL ET STOCKAGE DEFINITIF.

Les spécifications techniques applicables au conditionnement des produits radioactifs destinés au stockage définitif n'étant pas encore fixées par l'Agence Nationale pour la gestion des Déchets Radioactifs (ANDRA), nous avons fait en sorte que tous les conditionnements soient réversibles, afin de faciliter le plus possible une réduction des volumes à stocker, ce mode de conditionnement permettant par ailleurs de procéder à une éventuelle récupération des produits radifères, au cas où de nouvelles applications apparaîtraient ultérieurement.

7 - CONCLUSIONS

L'expérience acquise depuis quelques années a permis de valider l'organisation mise en place et de constater la nécessité, au niveau national, d'un service spécialisé particulièrement qualifié disposant de tous les moyens appropriés pour remplir une telle mission.

THE MIGRATION OF Cs-137 THROUGH THREE DIFFERENT FORMULATIONS OF COMPRESSIVELY STRESSED GROUT

Richard R. Brey and Robert R. Landolt

School of Health Sciences
Civil Engineering Building
West Lafayette, Indiana 47907

ABSTRACT

The effect of uniaxial, unconfined compressive stress on ¹³⁷Cs penetration into grouts containing either flyash, silica fume or no admixture was investigated. Cylinders from three formulations of grout were compressively stressed to either 0, 40, 70, or 90 percent of their construction strength, then placed into an apparatus which produced a hydrostatic pressure head gradient along the cylinder axis of 103 ± 21 kPa using a ¹³⁷Cs salt solution. Cylinders were sliced into thin disks and the relative ¹³⁷Cs quantity in each disk was measured. The use of admixtures resulted in decreased penetration of the ¹³⁷Cs into the grout. Penetration was observed to go through a maximum near the mid-range stress values.

INTRODUCTION

Several design proposals exist for low level radioactive waste shallow land and above grade disposal facilities. These designs include such systems as simple trenches, concrete vaults, and excavated caverns. All incorporate cementitious barriers of some fashion. These barriers will play an important role in enhancing system performance.

It is well documented that microfractures begin to develop in cement aggregate matrices when the composite is stressed compressively to values greater than 40% of maximum strength. These will develop across the matrix and along aggregate boundaries. Microfracturing persists under load until failure. This investigation was intended to observe the effect of stress on ¹³⁷Cs penetration into cementitious grouts.

EXPERIMENTAL MEASUREMENTS

A ¹³⁷Cs salt solution under a hydrostatic pressure gradient of 103 ± 21 kPa was applied to one face of cementitious grout test cylinders (2.54 cm in diameter, 5.08 cm long) for 30d to investigate the effect of stress on penetration. Three formulations of grout varying only in the admixture type used were considered. The first formulation was a mixture of sand, portland type I cement, and water (cement/sand = 0.5 by volume, water/cement = 0.4 by

weight). The second was a mixture of sand, portland type I cement, type F flyash, and water (cementitious material/sand = 0.5 by volume, cement/flyash = 7/3 by volume, water/cement = 0.4 by weight). The last mixture was a combination of sand, cement, silica fume, and water (cementitious material/sand = 0.5 by volume, cement/silica fume = 7/3 by volume, water/cement = 0.4 by weight). After curing at $35 \pm 3^\circ\text{C}$ while submerged in a saturated $\text{Ca}(\text{OH})_2$ solution for 30d the cylinders of each formulation were compressively stressed to 0, 40, 70, or 90 percent of their construction strength prior to the 30d hydrostatic pressure treatment. Construction strength is defined as the average maximum strength at failure minus the standard deviation of the maximum strength distribution. Unconfined compressive stress was applied using a Satec, computer controlled, hydraulically operated, universal testing machine. The load rate used was 185 ± 3 newtons/s. After reaching the desired load level the load was maintained for 30s prior to removal. After the hydrostatic treatment the cylinders were sliced into thin disks in a radiological glove box. The relative quantity of ^{137}Cs in each disk was determined using $\text{NaI}(\text{Tl})$ scintillation crystals and appropriate electronics. Analyses of data followed two strategies. One considered graphical characteristics of plotted data, the other considered raw data corrected for background and normalized by weight. Both strategies used analysis of variance and pairwise comparisons to establish and elaborate on differences between treatments. Figure 1 demonstrates the graphical characteristics analyzed. Figure 2 is an example of a typical semi-logarithmic raw data plot. It is representative of the data obtained from each test cylinder.

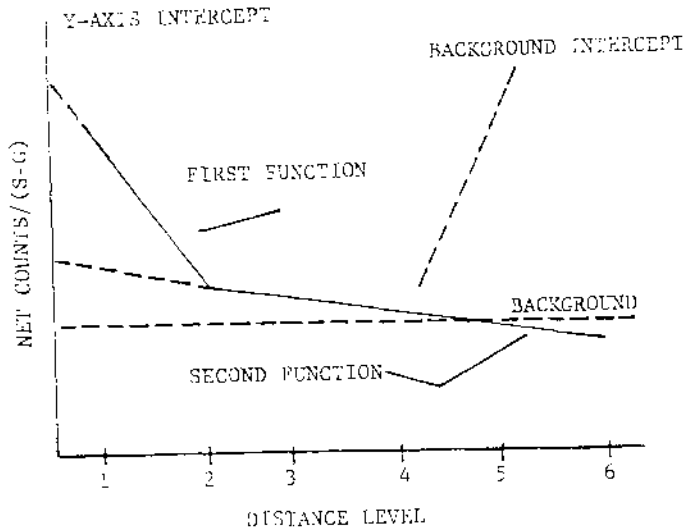

Fig. 1

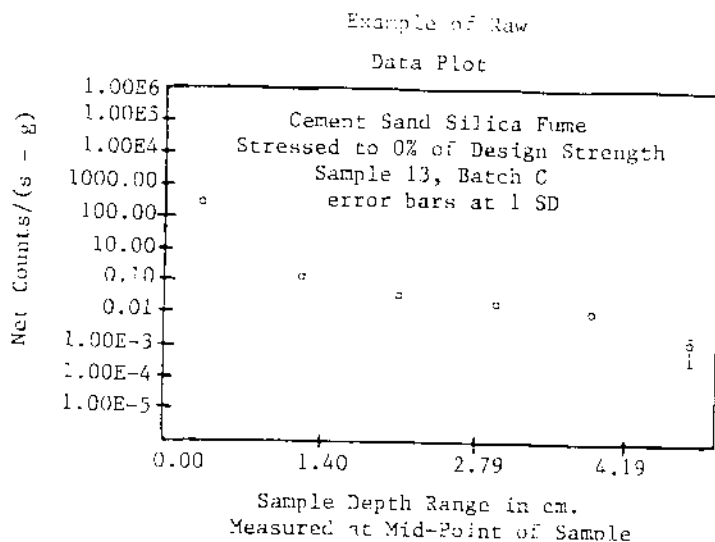

Fig. 2

RESULTS AND CONCLUSIONS

Cementitious grouts containing silica fume or type F flyash performed better as containment barriers than plain grout mixtures in resisting ^{137}Cs penetration. The total depth of penetration with formulations containing admixtures was about one half that experienced with the formulation without admixtures.

Penetration seems to be governed by two distinct phenomenon as illustrated in Figure 1; one very significant near the surface, the other less pronounced throughout the rest of the specimen. The surface effect was about 20% stronger in formulations containing silica fume or flyash admixtures than in the formulation without an admixture.

The lowest ^{137}Cs penetration was consistently observed at the 0% stress level. Penetration was higher at the 40% and 70% stress levels and decreased at the 90% stress level. A cause of these trends may be a complex interrelation between active exchange sites and available effective surface competing with pore connectivity and size. The density of exchange sites is probably uniform over the surface area but varies among different formulations. The effective surface area available for exchange is expected to increase rapidly with stress. Low penetration at the 0% stress level may be related to the lack of pore connectivity. Increased penetration at the 40% and 70% stress values is attributed to increased pore connectivity. However, this is also accompanied by an increased number of exchange sites. As stress increases further, an increased number of exchange sites associated with a rapidly increasing effective surface area begins to greatly enhance the ^{137}Cs absorption and hence reduce the penetration. The result of this is the decreased penetration at the 90% stress level.

REFERENCES

Bauer, L., Ph.D. Thesis. Purdue University, West Lafayette, IN 47907, December 1988. Gas Phase Migration of C-14 Through Barrier Materials Applicable for Use in a High-Level Nuclear Waste Repository Located in Tuff.

Breiner, E.M. Low-Level Radioactive Waste Disposal: Technology and Public Policy. Journal of Environmental Science, 29(4):47-56, 1986.

Hibtanen, R., Jaakkola, T., Miettinen, J.K. Sorption of Cesium, Strontium, Iodine and Carbon in Concrete and Sand. Materials Research Society Symposium Proceedings, Materials Research Society, (44)891-898, 1985.

Hoglund, S., Eliasson, B., Allard, K., Anderson, K., Torstenfelt, B. Sorption of Some Fission Products and Actinides in Concrete Systems. Materials Research Society Symposium Proceedings, Materials Research Society, (50)683-690, 1985.

Jakubick, A.T., Gilliam, R.W., Kahl, I., Robin, M. Attenuation of Pv, Am, Cs and Si Mobility in Concrete. Materials Research Society Symposium Proceedings, Materials Research Society, (84)355-368, 1987.

Kaplan, M.F. Crack Propagation and the Fracture of Concrete. Journal of the American Concrete Institute, (11)58:591-608, 1961.

Mindess, S., Young, F.J. Concrete. First Printing. Englewood Cliffs, N.J., Prentice-Hall, Inc., 1981.

Neville, A.M., Brooks, J.J. Concrete Technology. First Printing. New York, John Wiley & Sons, Inc., 1987.

Nyame, B.K., Illston, J.M. Relationship Between Permeability and Pore Structure of Hardened Cement Paste. Magazine of Concrete Research, (33)116,139-146, 1981.

Rudin, M.J., Ph.D. Purdue University, West Lafayette, IN 47907, December 1989. The Migration of Cesium-137 through Cement Formulations Applicable to Radioactive Waste Management.

Spinks, J.T., Baldwin, H.W., Thorvaldson, T. Tracer Studies of Diffusion in Set Portland Cement. Canadian Journal of Technology, (30)20-28, 1951.

ACKNOWLEDGEMENTS

Partial support for this research was provided by a fellowship from the Health Physics Society.

Probabilistic Approach to NDA for Non-uniform Radwastes

Myung C Lee, Duck J Koh, Seung G Ro, and Hee S Shin

Safety Analysis Department
Korea Atomic Energy Research Institute
Taejon, Korea

ABSTRACT

For nondestructive assay of low-level wastes a specific-purpose Monte Carlo code, MCRWA(A Monte Carlo code for Radioactive Waste Assay), was developed to simulate the entire energy spectral response for sources within an assayed container and to analyze the effect of scattered photons from higher energy gammas on the spectrum of a low energy gamma-ray. With the developed code the design optimization of nondestructive assay systems was performed and the probabilistic approach for the data interpretation was discussed.

INTRODUCTION

Non-destructive assay of radioactive wastes produced from nuclear power plants and fuel cycle facilities is required for the purpose of assessing the disposal risks. Such assay is influenced by two distinct facts. The first is the statistical uncertainty of the measurement resulting from randomness in the counting process. The other is the spatial uncertainty due to the random or unknown spatial distribution of the assayed material(analyte) in a waste container. Different spatial distributions of different quantities of the analyte may lead to same detector responses. Thus, such a spatial randomness of the analyte results in a significant source of uncertainty in interpreting the measurement and may require a probabilistic approach^{1,2)}. The probabilistic approach enables one to determine a probability distribution that a certain amount of the analyte is contained for a measured response instead of a single value based on a hypothetical distribution.

The basic assumption in the probability determination is that the loading of waste into the container volume is a random process. And the probability of finding a certain amount of the analyte and matrix materials in each volume element of the container is identical. Having identified various possible spatial distributions of the analyte and matrix in the container's volume, the probability for each to occur can be derived.

MONTE CARLO SIMULATION OF ASSAY SYSTEM RESPONSE.

A key point of nondestructive assay system in the present study is how to obtain the average response of a single point-source of unit intensity with a large volume HPGe detector. In most practical applications accurate analytical models for the point source response are impossible to obtain. In such cases, Monte Carlo simulation offers the only way to generate the point source response, short of doing a large and tedious set of experiments.

A Monte Carlo code, MCRWA (Monte Carlo code for Radioactive Waste Assay) was developed to simulate the entire energy spectral response for point sources located within the assayed sample. The significant features of the developed MCRWA code are that it can be used not only for obtaining the averaged detector response but also for predicting the photon energy spectra of all gammas emitted from multiple radionuclides within the sample. Therefore, the simulated entire pulse-height spectrum with the HPGe detector can be useful for estimating the effect of scattered radiations from high energy gammas on the pulse height spectrum of a low energy gamma ray.

The focus in the study is on the tracking of gamma rays from the source in the sample to the detector. In order to reduce the variance of the output from the Monte Carlo simulation, suitable variance reduction methods such as Russian roulette were used. During the tracking of photons the statistical estimation techniques were used at every collision point to score the gamma-ray intensities detected.

DESIGN OPTIMIZATION OF ASSAY SYSTEM

In a practical case nuclear assay of low- and intermediate- level radioactive wastes generated from nuclear power plants will be done passively using gamma-ray detector responses. In order to demonstrate the use of convexity analysis²⁰ in the assay system design, a cylindrical drum of small size was selected because it has the potential for extension to practical situations. The design procedure developed with this simplified geometry is also thought to be extended easily to practical situations. The sample diameter and height were 16 and 32 cm, respectively. The matrix of sample was polyethylene or cement. The analytes were Pu-239 at 384 keV complex, Cs-137 at 662 keV, and Co-60 at 1,173 keV.

The design problem was to choose the optimum number and deployment of detectors for a given sample shape and size, for a given detector type, and for passive gamma-ray assay. Point source response sets obtained from Monte Carlo simulation was used for calculations of the Relative Mass Resolution (RMR) which is a quantitative measure of the performance of each proposed design. These response sets included the unscattered gamma-ray responses or both the scattered and unscattered gamma-ray responses of detectors. Detail results of optimized assay system design will be given at the presentation time.

PROBABILISTIC INTERPRETATION OF MEASUREMENT

If the spatial distribution of the analyte in the sample is unknown, then this spatial uncertainty will be an additional factor contributing to the measurement uncertainty and the interpretation of measured responses in terms of contained mass will be non-unique. Hence this uncertainty precludes the use of a simple model for design purposes and also precludes the unambiguous calibration of the assayed system based on standardized samples since different spatial distributions of same quantity of the analyte may give different activity readings. A probabilistic approach may be the best solution to these kinds of assay problems.

In this paper two kinds of probabilistic approaches were discussed. One is based on the concept of maximum likelihood. That is, the average response is interpreted as arising from the value of m which maximizes $p(g|m)$ on the set of values of m , where m is the quantity of the analyte and $p(g|m)$ is the conditional probability density of the response given the quantity of the analyte. The other is based on A. Knoll's concept⁴ that analyte and matrix compartments within the sample exist such that within a compartment the material distribution is uniform. The boundaries of the compartment are random variables with probability density functions associated with them. Knoll's methodology was extended and adapted to the data interpretation of the proposed assay system. The comparison of results from two approaches will be given at the presentation time.

SUMMARY AND CONCLUSIONS

The assay system presented in this study is based on a "one-shot" geometry. The spectrometer's angle of view covers the whole examined container. The count rate of the detector resulting from a certain characteristic gamma energy emitted by the source material is referred to as the assay system response. The obtained mass probability curve can be used for distribution characteristics such as first moment, uncertainty within specific confidence level, and most probable mass, etc. The dispersion of the curve shown in Fig. 2 presents the spatial variance for possible allowed distributions of masses.

The averaged entire pulse-height spectral response for sources located within the sample was obtained by the convolution of the Monte Carlo generated energy spectrum with the spectral response function of a large volume germanium detector^{5,6}. The comparison of pulse-height spectrum generated by Monte Carlo simulation and then convolved with the detector response function to the corresponding spectrum measured by using a Cs-137 photon source is shown in Fig. 3. The agreement between the Monte Carlo simulated and experimental results is quite good. In case that the sample contains multiple radionuclides which differ in their characteristic gamma-ray energies and one wants either to assay a radionuclide or to assay whole radionuclides in the drum simultaneously, the response of the detector for each nuclide is required separately. But the measured response may include both the response of radiations from the assayed nuclide and the responses of the scattered radiations from higher energy gammas. One can eliminate the scattered radiation contribution of higher

energy gammas from the measured response by subtracting the complete pulse-height spectra of higher gamma-ray energies from the measured complete pulse-height spectrum sequentially. In this method, however, large accumulated errors will be propagated to final results due to the subtractions. To avoid such accumulated errors, a library least-squares analysis technique⁷ provides better solution to the proposed problem. With this technique one can estimate the detector response for each nuclide in the assayed sample at a time. The specific-purpose Monte Carlo code, MCRWA(Monte Carlo code for Radioactive Waste Assay), seems to be valuable for other assay systems.

REFERENCES

1. Y. Ben-Haim and E. Elias, "Probabilistic Interpretation of Non-destructive Assay of Nuclear Material," Ann. Nucl. Energy, 9, 1(1982).
2. Y. Ben-Haim, E. Elias, and T. Gozani, " Probabilistic Approach to NDA of Container with Non-uniform SNM Distribution," J. Inst. Nucl. Manage. XI, 69(1982).
3. Y. Ben-Haim, The Assay of Spatially Random Material, D. Reidel Publishing Co., Dordrecht, Holland(1985)
4. A. Knoll, A. Notea, and Y. Seagal, "Probabilistic Interpretation of Nuclear Waste Assay by Passive Gamma Technique," Nucl. Tech. 56, 361 (1982).
5. M. C. Lee, et al., "A Semi-Empirical Germanium Detector Response Function for 0.06 - 6.2 MeV Gamma Rays," Trans. Am. Nucl. Soc. 55, 555, Nov.(1987).
6. M.C. Lee, et al., "Expansion of the Semi-Empirical Germanium Detector Response Function to Low Energy Gamma Rays," Nucl. Instr. and Meth. in phys. Res. A262, 430 (1987).
7. K. Verghese, et al, "A New Analysis Principle for EDXRF: The Monte Carlo - Library Least-Squares Analysis Principle," Advances in X-ray Analysis, Vol. 31, (1988).

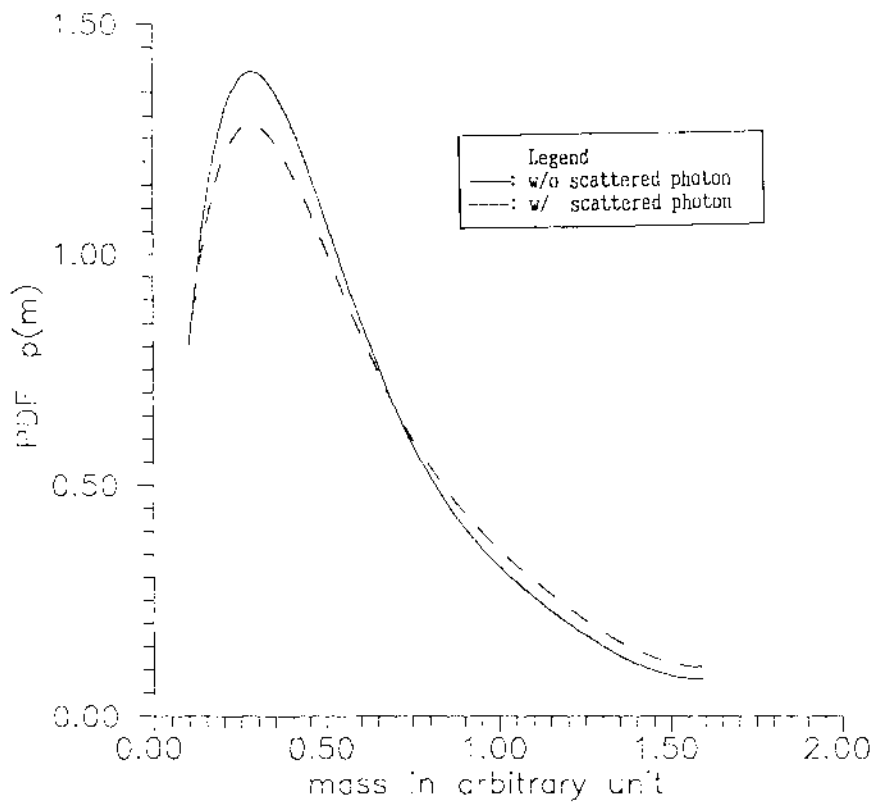

Fig. 1 Probability density functions of mass in the cylindrical waste drum. The matrix material is polyethylene.

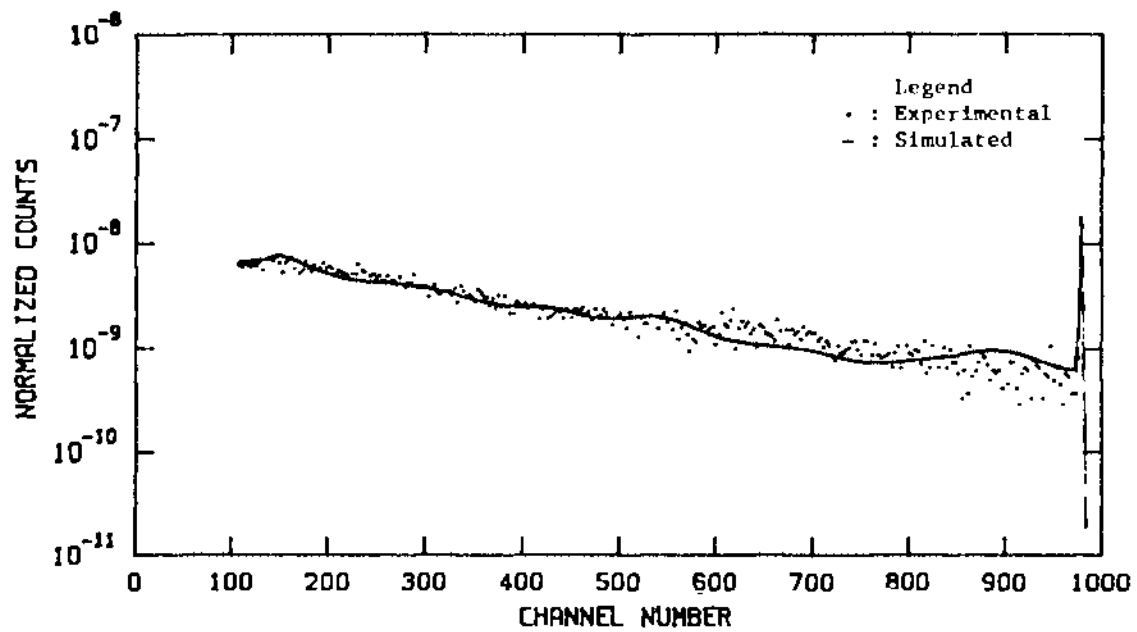

Fig. 2 Experimental and simulated ^{137}Cs spectra. Energy = $3.595 \times 10^{-9} + 6.71823 \times 10^{-4} \times \text{ch \#}$.

ON THE REDUCTION OF ^{222}Rn EXHALATION FROM ^{226}Ra -RICH WASTES
BY COVERING OF SOIL

Y. IKEBE

Department of Nuclear Engineering, School of Engineering,
Nagoya University, Chikusa-ku, Nagoya 464-01, Japan

ABSTRACT

The reduction effect for Rn-222 exhalation from a Ra-226 containing wastes by covering of ordinary soil is calculated. Although the concentration profile of radon in the soil for two layer model is quite different from that for three layer model, exhalation rates are not so much differ between the two models. It is shown that the effective diffusion coefficient of the soil is very effective for radon exhalation.

INTRODUCTION

Recently, concern of peoples about environmental radon is increasing gradually. In some occasions, we shall have to reduce the activity level in air of radon exhaled from wastes such as uranium tailings, excavated Ra-rich soil from various kinds of mine, and so on. In order to reduce the Rn-222 exhalation from such wastes, a covering of normal soil upon the wastes may be practical and useful.

In this paper, the reduction effect for Rn exhalation from wastes by covering of normal soil is evaluated by calculation using various soil parameters such as Ra-226 content, Rn escape-to-production ratio, air ratio, and effective diffusion coefficient of Rn.

MODEL

First, we consider two layer model: First layer is ordinary soil of thickness H_1 . Second layer is wastes of thickness H_2 . Under steady state conditions, the diffusion of radon through soil to surface can be expressed in each layer by the diffusion equation^{1,2)}

$$D \frac{d^2 C}{dz^2} + a - \lambda C = 0$$

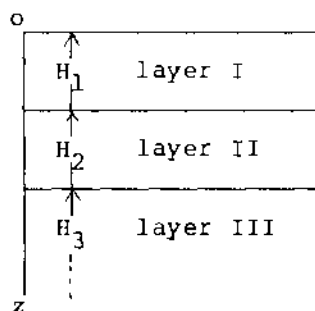

where $C(z)$ is the concentration of radon atoms in soil air ($\text{atom}\cdot\text{cm}^{-3}$ of soil air), a is the supply rate of radon atom to soil air ($\text{atom}\cdot\text{cm}^{-3}$ of soil air $\cdot\text{s}^{-1}$), λ is the decay constant of radon (s^{-1}), and D is the effective diffusion coefficient of radon in soil air ($\text{cm}^2\cdot\text{s}^{-1}$).

If we denote δ is the escape-to-production ratio of radon (-), n is the air ratio (=air volume)/(total volume of soil), (-), A is the Ra-226 activity ($\text{Bq}\cdot\text{cm}^{-3}$ of soil), C_g is the

concentration of radon atoms existing in soil air (atom·cm⁻³ of soil), then $C_s = nC(z)$ and $a = \delta A/n$.

The boundary conditions are given by $C_1(0) = 0$, $n_1 C_1(H_1) = n_2 C_2(H_1)$, $(C_{s1}(H_1) = C_{s2}(H_1))$, $\lambda C_2(\infty) = a_2$,

$$\text{and } D_1 \left(\frac{dC_{s1}}{dz} \right)_{H_1} = D_2 \left(\frac{dC_{s2}}{dz} \right)_{H_1} .$$

The solutions are given by:

$$\text{At first layer } C_1(z) = A_1 \exp\left(\sqrt{\frac{\lambda}{D_1}} z\right) + B_1 \exp\left(-\sqrt{\frac{\lambda}{D_1}} z\right) + \frac{a_1}{\lambda}$$

$$\text{where } A_1 = \left\{ \frac{a_1}{\lambda} \left(1 - \sqrt{\frac{D_1}{D_2}}\right) \exp\left(-\sqrt{\frac{\lambda}{D_1}} H_1\right) - \frac{n_1 a_1 - n_2 a_2}{\lambda n_1} \right\} /$$

$$\left\{ \left(1 + \sqrt{\frac{D_1}{D_2}}\right) \cdot \exp\left(\sqrt{\frac{\lambda}{D_1}} H_1\right) - \left(1 - \sqrt{\frac{D_1}{D_2}}\right) \exp\left(-\sqrt{\frac{\lambda}{D_1}} H_1\right) \right\}$$

$$B_1 = -\left(A_1 + \frac{a_1}{\lambda}\right) .$$

$$\text{At second layer } C_2(z) = B_2 \exp\left(-\sqrt{\frac{\lambda}{D_2}} z\right) + \frac{a_2}{\lambda}$$

$$\text{where } B_2 = -\frac{n_1}{n_2} \sqrt{\frac{D_1}{D_2}} \exp\left(\sqrt{\frac{\lambda}{D_2}} H_1\right) \left\{ \exp\left(\sqrt{\frac{\lambda}{D_1}} H_1\right) \right.$$

$$\left. + \exp\left(-\sqrt{\frac{\lambda}{D_1}} H_1\right) \right\} A_1 + \frac{a_1}{\lambda} \exp\left(-\sqrt{\frac{\lambda}{D_1}} H_1\right) .$$

The exhalation rate, E (atom·cm⁻²s⁻¹), at the surface is given by

$$E = -n_1 D_1 \left[\frac{dC_1}{dz} \right]_{z=0} = -n_1 D_1 \left(A_1 \sqrt{\frac{\lambda}{D_1}} - B_1 \sqrt{\frac{\lambda}{D_1}} \right)$$

Secondly, three layer model was treated, in which the third layer corresponds to the basic ground ($H_3 = \infty$). The formulae of $C_3(z)$ and E were obtained analytically using similar boundary conditions to those used for the two layer model.

CALCULATION

The parameters used for the present work are $D_1 = D_2 = D_3 = D = 0.054$, $0.054/10$, $0.054/100$, $n_1 = n_2 = n_3 = 0.1$, $a_1 = a_3 = 1$, and $a_2 = 1, 10, 100$.

Fig. 1 Shows the results for two layer model. In Fig. 1 (1), profile of Rn existing in soil air (Bq·cm⁻³ of soil) is given as a parameter of $D_1 = D_2 = D$ assuming $a_1 = 1$, $a_2 = 100$, $H_1 = 100$

and $H_2 = \infty$. In Fig. 1 (2), profile is given as a parameter of H_1 assuming $a_1 = 1$, $a_2 = 100$, $D_1 = D_2 = D = 0.054/10$, and $H_2 = \infty$.

Fig. 2 shows the results for three layer model. In Fig. 2(1), $C_S(z)$ (Bq.cm⁻³ of soil) is given as a parameter of $D_1 = D_2 = D_3 = D$ assuming $a_1 = a_3 = 1$, $a_2 = 100$, $H_1 = H_2 = 100$, and $H_3 = \infty$. Fig. 2 (2) gives the profile as a parameter of H_1 assuming $a_1 = a_3 = 1$, $a_2 = 100$, $D_1 = D_2 = D_3 = D = 0.054/10$, $H_2 = 100$, and $H_3 = \infty$.

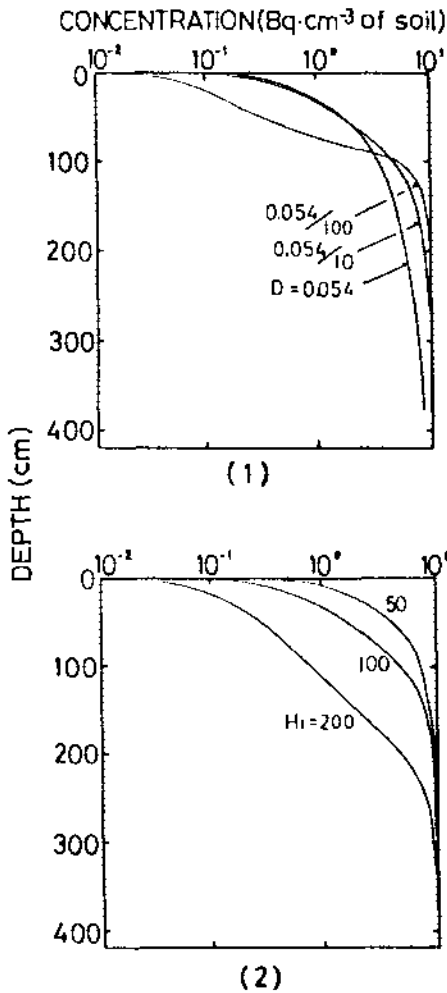

Fig. 1 Rn profile in soil (two layer model)

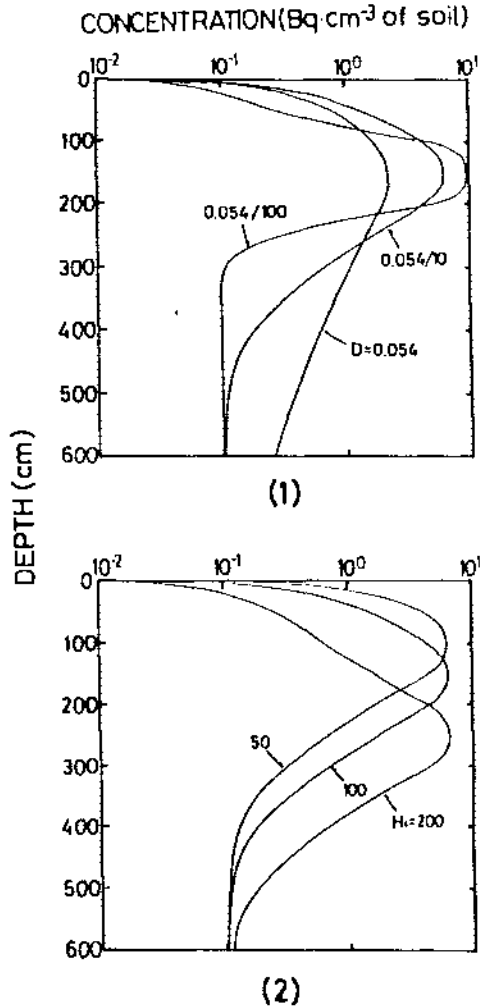

Fig. 2 Rn profile in soil (three layer model)

Fig. 3 shows the calculated exhalation rates, E , for two layer model (broken line) and for three layer model (solid line). In Fig. 3(1), E is shown as a function of H_1 for a parameter of $D_1 = D_2 = D_3 = D$ assuming $a_1 = a_3 = 1$, $a_2 = 100$, $H_2 = \infty$ (two layer), $H_2 = 100$ and $H_3 = \infty$ (three layer). Fig. 3(2) gives E as a function of H_1 for a parameter of a_2 assuming $a_1 = a_3 = 1$, $D_1 = D_2 = D_3 = D = 0.054/10$, $H_2 = 100$, and $H_3 = \infty$.

RESULTS AND DISCUSSIONS

Although the present model is simple and parameters used are assumptive, we may get some informations from the present calculation. Comparing Fig. 1 and Fig. 2, the profile of $D_S(z)$ for two layer model is quite different form that for three layer model. But as is shown in Fig. 3, exhalation rate for two layer model is not so much differ from that for three layer model. It is also seen that D is very effective for the value of E^3 , which suggests that radon exhaled from wastes can be effectively reduced by covering of soil of low effective diffusion coefficient. The present treatment may also be applicable for natural multi-layer soil.

REFERENCES

1. Kataoka, T., Ikebe, Y., and Minato, S., 1979, Influence of the Distribution of Rn-222 Concentration under the Ground on Natural Gamma-Ray Flux Density and Exposure Rate, Health Phys., 37, pp.669-675.
2. UNSCEAR, 1982, Ionizing Radiation, Source and Biological Effects, Appendix D, pp.150-151, United Nations, New York.
3. Kataoka, T. and Ikebe, Y., 1982, Measurement of Soil Concentration Profile of Radon-222 and Its Effect on Exposure Rate, J. Nucl. Sci. Technol., 19, pp.757-761.

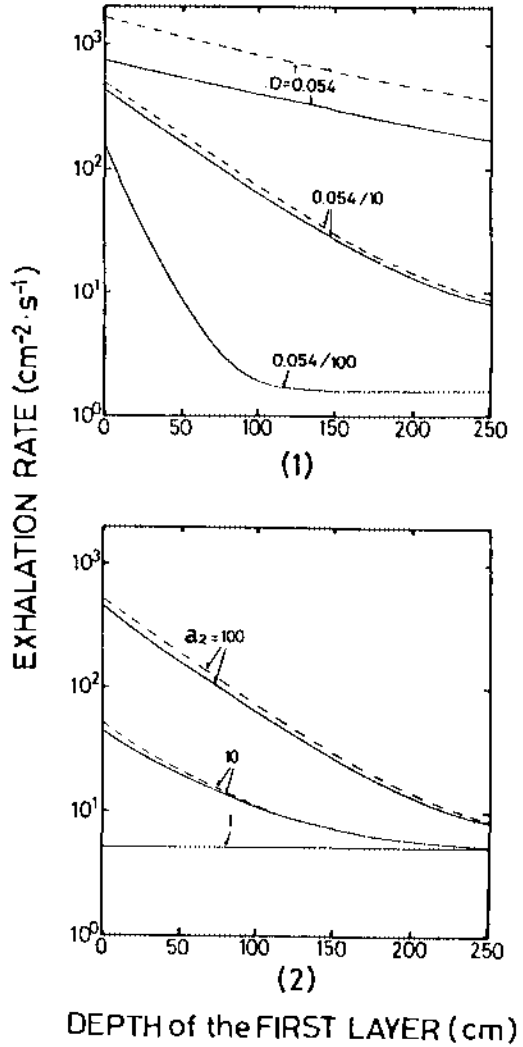

Fig. 3 Calculated exhalation rate as a function of the first layer

**The Development of Internationally Accepted Exempt levels
of Radionuclides in Solid Materials**

G.S. Linsley
International Atomic Energy Agency, Vienna, Austria

The principles for exempting radiation sources and practices from regulatory control, which were the subject of an international consensus in 1988, have been applied in the waste management area. Guidance has been developed on methodologies for evaluating exempt concentrations and quantities of low level radioactive wastes from industry, medicine and research and of materials intended for recycle and reuse. Recommendations are being formulated on exempt values applicable to all materials and wastes irrespective of their fate after control has been relinquished.

COMPARISON BETWEEN RADIOLOGICAL PROTECTION AGAINST IONIZING RADIATION AND NON IONIZING RADIATION

H.P. JAMMET
Chairman Emeritus IRPA/INIRC and Vice Chairman ICRP
PARIS, FRANCE

INTRODUCTION

Protection against IR and NIR developed in completely different ways because of the very different evolution of the techniques they involve. While as soon as 1928, the International Society of Radiology created the International Commission of Radiological Protection, we had to wait until 1977 to see the creation of the International Committee for NIR (INIRC) by IRPA. To compare protection against Ionizing Radiations and Non Ionizing Radiations we will first carry out a general analysis of its components and then we will draw the general conclusions leading to a quite comparable evolution.

I GENERAL ANALYSIS

The general analysis will be carried out on the definitions, the radiation/matter interactions and the biological effects, the quantities and units, the sources and the exposures, radiological protection itself and finally monitoring and surveillance.

1. DEFINITIONS

The definition of the characteristics of ionizing and non-ionizing radiations is rather complex due to their often heterogenous components.

Ionizing radiation conventionally includes two distinct categories : electromagnetic radiation of photon with energy higher than that of ultra-violet rays (X and gamma rays), and particulate radiation formed of fragments of matter (electrons, beta-rays, neutrons, alpha-rays).

Non-ionizing radiation normally includes electromagnetic radiation with energy less than that necessary to produce ionization : optical radiation (UV, visible, IR) incoherent and coherent (lasers), and waves (microwaves, radiofrequencies, radar, extremely weak electromagnetic fields). Added for various reasons are static electric and magnetic fields, as well as the part of acoustics including ultrasound.

This discussion focuses mainly for comparison purposes on electromagnetic radiation, of which ionizing and non-ionizing radiations cover the entire spectrum from the highest energy cosmic rays to zero frequency electric and magnetic fields.

2. RADIATION/MATTER INTERACTIONS

The understanding of the action mechanisms of radiation is directly related to the penetration of this radiation into living matter, and to its interaction with it.

Parameters associated with exposure : duration and distribution of exposure in time (continuous or intermittent exposure), distance from the source (except for lasers emitted by a source considered as a point), orientation of the exposed subject in the radiation field, and spatial distribution of the exposure (total or partial exposure of the organism).

Parameters related to biological characteristics : cellular and even molecular construction of the exposed tissues, electrical properties, certain physiological properties such as blood irrigation in the event of thermal effects, the dimensions of the organ or the subject, and the functional importance of the tissues or organs affected.

The study of the effects of ionizing radiation on living beings is the domain of two disciplines : one scientific, radiobiology, and the second medical, radiopathology.

Radiobiology is concerned with all the effects of radiation, whether they are beneficial or harmful, and attempts to determine the mechanisms. These are related to the whole organisms, organs and tissues, cells, cell components, or molecular biology.

Radiopathology is concerned only with the harmful effects of radiation.

3.2 IONIZING RADIATION

A number of high general exposures revealed the sensitivity of the haematopoietic tissues and germinal tissues, causing haematopoietic depressions and sterility. A large number of studies have been devoted to harmful rays, namely to death by irradiation due to haematological, visceral or neurological syndromes, treated by brand new methods, such as organ transplants. Attention was then drawn by the induction of cancers : leukemia in radiologists, sarcoma in radium painters, bronchopulmonary cancers in uranium miners, various types of cancer for atomic bomb victims of Hiroshima and Nagasaki. Following the discovery of the genetic action of radiation on the experimental level, an attempt was made, nearly always in vain, to identify the induction of hereditary diseases by epidemiological investigations. The latest induction of manifestations of mental retardation after foetal exposure is between eighth and the sixteenth week of gestation.

3.3 NON IONIZING RADIATION

For the non-ionizing radiation the type, scale and importance of the effects generated are extremely variable, and apparently depend on an even larger number of factors than ionizing radiation. If the energy of the incident photons is vital because it conditions their penetration depth into the tissues and their preferential absorption by a specific type of molecular structure, the field intensity, the radiation emission mode (coherent or non-coherent, continuous or pulsed), the size and geometric configuration of the subject, the cell structure of the irradiated tissues, and often even certain psychological characteristics, such as blood irrigation of the tissues, are equally important factors. In fact, although in recent years interest has grown considerably in the biological effects of NIR, and an increasing number of research projects is devoted to this subject throughout the world, the precise role played by these different parameters, their interference, and specially their quantitative relationships with the biological effect produced, are still very poorly known.

The problems raised and the difficulties encountered by biologists are quite similar to those occurring in the area of ionizing radiation. Apart from the parameters mentioned above, the seriousness of the effects depends on the distribution of radiations (partial or total irradiation), and on the sensitivity and the size of the target organs. As a rule, two types of effects are found here, stochastic and non-stochastic. Certain non-stochastic effects are relatively well-known, as for example erythema and burns of the skin, as well as ocular effects (conjunctivitis, retinal burns, cataract) for optical radiations, effect

resulting from the heating of the tissues, routinely called thermal effects, due to high energy fluence microwaves. It has been possible to determine the occurrence thresholds.

On the other hand, considerable uncertainty subsists on the non-thermal effects that may be produced by microwaves, particularly at the low energy fluence rates. The results obtained appear to show that, in certain frequency ranges, electromagnetic waves can induce biological effects, which are not due to simple heating, at the level of the nerves, endocrine and immune systems, for example. Furthermore, it now seems clear that an energy fluence rate interval exists, called a "window", below which certain effects can appear that are produced by low fluence rate microwaves.

As for the stochastic effects (induction of cancers, genetic effects), while it is well-known that they exist in certain cases (skin cancer due to ultraviolet radiation), we are still in the stage of preliminary research for the other types of NIR.

4. QUANTITIES AND UNITS

The quantities and units employed for ionizing and non-ionizing radiations are quite different in practice for historical reasons, stemming from the compartmentalization of the different disciplines such as radiology, radiobiology, radiopathology, photobiology, optics, telecommunications and acoustics. For ionizing radiation, after having used exposed units such as the röntgen, the units applied today refer to the dose absorbed in the material, such as the gray and the sievert.

For non-ionizing radiation, the conventional units of optics and acoustics are employed. Energy densities in J/cm^2 or power densities in W/cm^2 are used for radiofrequencies. This is the energy through a surface. We are moving towards quantities related to the energy absorbed per unit volume or mass, such as the specific absorption rate.

The International Commission for Radiological Units and Measurements has undertaken a laudable effort to harmonize and standardize the basic concepts of metrology for all forms of radiation.

5. SOURCES

Radiation sources are either natural or artificial, modified or created by man. Natural ionizing radiation sources include cosmic and telluric components causing external irradiation (gamma-rays) and internal irradiation (^{40}K , radioactive families of uranium and thorium). Artificial sources consist essentially of generators of X rays and radioactive substances, sealed or otherwise, used in medicine, industry and research. However, a special mention must be made concerning atomic energy, of which the nuclear cycle ranges from uranium mines to radioactive wastes, including enrichment plants, nuclear reactors and reprocessing facilities.

Natural non-ionizing radiation sources consist essentially of solar radiation (UV, visible, IR), cosmic radiation formed light or radiofrequencies which are extremely weak. Artificial sources are many and varied in the field of optics, waves and ultrasonic acoustics, employed in industry, research, medicine and home appliances. Rapid advances are being achieved for lasers, radar systems and telecommunications.

From the quantitative standpoint, it is interesting to note that raw or domestic natural sources outnumber artificial sources, while the situation is comparable for optical radiation, but is the opposite for radiofrequencies and ultrasound.

6. EXPOSURES

Human exposure to radiation are extremely variable and quite different in method and scale. However, it is closely comparable for ionizing and non-ionizing radiation.

In fact, it can take place in everyday life, on the job, and even during radiological medical practice. This concerns general exposure of the public, occupational exposure of workers, and medical exposure of patients. In compiling an overall balance, it can be observed that public exposure is the greatest, followed by medical exposure, with occupational exposure coming last. However, the individual balance shows that certain workers or patients belong to higher irradiation groups.

7. RADIOLOGICAL PROTECTION

7.1 PROTECTION PURPOSES

Credible protection and acceptability. What are the objectives of radiological protection? From the outset, it has tried to prevent non-stochastic damage, essentially radiological burns and haematological depressions. Subsequently, with the growth of knowledge about the carcinogenic and mutagenic effects, it has attempted to reduce stochastic damage, namely the induction of cancers and hereditary diseases.

Why this diversity of objectives for effects with different correlation? In the first case of non-stochastic damage with a deterministic correlation, thresholds exist below which no radiopathological manifestation occurs. Hence, for doses lower than these thresholds, damage can be avoided completely, and absolute protection guaranteed. In the second case of stochastic damage, prudence has led to the assumption of the non-existence of thresholds, and hence only the ability to reduce the probability of induction of cancers or hereditary diseases. Protection can only provide a relative guarantee.

7.2 APPROACHES TO PROTECTION PROBLEMS

The approaches to the problems of radiological protection has also been the subject of considerable change over the years.

Initially the problems raised concerned a small number of individuals : pioneers in scientific research, practioners in medical applications of radiation. It was normal for the approach to be individual. One was concerned with guaranteeing adequate protection for each worker or for each individual belonging to the so-called critical group of the most exposed persons. Thus standards were progressively established, essentially in the form of individual exposure limits. Subsequently, with the growth of the number of sources and their size, radiological protection was forced to focus on problems associated with the sources themselves. Since a given installation was capable of irradiating a large number of persons, it became indispensable to use a collective approach to the problems arising. The individual exposure limits were gradually supplemented by collective irradiation standards, related to the sources and enabling mutual comparisons between the protection levels.

This is why, in the present phase of radiological protection, the complementarity of the individual and collective approaches is culminating in a set of requirements, some of which concern the individuals subjected to irradiation from several sources, with others related to each source liable to irradiate a certain number of persons.

7.3 RADIOLOGICAL PROTECTION SYSTEMS

The individual and collective approaches to protection problems had the common basis of health and technological considerations. The former concerned standards relative to persons, and the latter those relative to sources. Yet the normal evolution of radiological protection, in the context of the growth of the industrial society, ultimately had to take account of economic and social considerations. The economy had to be quantified in order to compare the respective costs of the risks avoided and the related means of protection. Sociology focused its efforts on the adequate adaptation of protection to the delicate problem raised by the different levels of worker exposure, transborder radioactive pollution, and the spreading of exposure in the more or less distant future. Hence radiological protection proposes protection systems adapted to the foregoing considerations.

The initial recommendations were based on a limitation/minimization system. The limitation of exposure is reflected by maximum permissible doses. Since the exposure of individuals to the limits is undesirable, prudent but arbitrary safety factors were introduced, corresponding to a minimization process. A new protection system was recommended based on optimization/limitation. Optimization is aimed to analyze the various protection alternatives for the exposure sources, and to compare them in order to select the best one. The limitation of individual exposure is the guarantee for each person that the conditions of the optimal solution are acceptable for him.

7.4 PROTECTION AGAINST IONIZING RADIATIONS

In its Publication ICRP 90, the Commission recommends the following protection system :

- non practice should be adopted if its introduction does not realize a net benefit,
- all exposures must be kept at the lowest level that can be reasonably reached, in the light of economic and social factors,
- the dose equivalent for individuals should not exceed the limitations recommended for the circumstances in question

These three components correspond respectively to the principles of justification of the operations, optimization of protection and limitation of individual exposure.

It should be noted that the two principles of justification and optimization are vitally important conditions. The third principle, that of limitation is in fact an individual guarantee, because the distribution in the population of the benefits and costs is not the same.

Dose limitation culminates in protection standards. It is important to draw a distinction between types of protection standards : limits, constraints and levels.

- Fundamental limits

The fundamental limits consist in the primary and secondary limits. The primary limits are dose equivalent limits for the whole organism and the different organs or tissues. Secondary limits are given for external irradiation and internal irradiation. With respect to the external irradiation of the whole organism, the secondary limit applies to the maximum dose equivalent for the organism at more than 1 cm depth. For internal irradiation, the secondary limits are the annual limits of incorporation by inhalation or by ingestion.

. Constraints

The constraints are the upperbounds of optimization and can be established by a competent authority or by the management of an establishment. These constraints are lower than the limits. The minimization process is often employed in setting the constraints, but the optimization process should be used.

. Reference levels

Reference levels are not limits. They are used to determine the conduct required when a quantity exceeds or is liable to exceed the reference level. Exemption levels are fixed for the delineation of the scope of the system of radiological protection, below which it is not used.

Investigation levels can be defined as values of the dose equivalent or incorporation equivalent above which the results are considered sufficiently important to justify supplementary investigations.

Among the most widely used reference levels, ICRP mentions the intervention levels. These are defined as preset levels fixed so that it will be unnecessary to act as long as the value of the quantity measured or evaluated does not exceed this level. Above this level, action must not be automatic, because its timeliness and nature will depend largely on the situation. Furthermore, since action may interfere with the normal progress of operations or, in certain cases, break the normal chain of responsibilities, it should not be undertaken without due consideration.

7.5 PROTECTION AGAINST NON-IONIZING RADIATIONS

The analysis and synthesis of present knowledge on the pathological effects of NIR and the difficulties encountered in the monitoring of individual exposure have led the IRPA/INIRC to establish a protection doctrine based on the following principles :

- Compliance with health protection standards as defined in this document ensures adequate protection for occupationally exposed workers, and for members of the general public, against the hazards which might result from NIR,
- compliance with health protection standards should be guaranteed as far as possible by the development and compliance with performance standards which apply to the design and construction of NIR emitting devices,- when safety cannot be sufficiently guaranteed by construction (performance standards) due to the emitter characteristics or to its use, appropriate operational protection measures must be applied in order to comply with health protection standards.

Health protection standards : They consist mainly of limits that the various quantities defined above should not exceed (except in certain circumstances specified in the text). In the light of present knowledge acquired through animal experimentation and human observation, they are thought to represent the best values to allow the general use of NIR under safe conditions. However, given the limited nature of available data and the progress which will undoubtedly be made concerning the pathological effects of NIR, it can be assumed that these limits might eventually be modified (either increased or lowered) if and when it becomes necessary.

Device standards (Product performance standards) : because of the difficulties encountered in developing individual monitoring of exposure and therefore in ensuring compliance with health protection standards, it is all the more important to make provisions for the appropriate design and construction of the equipment and for the control and approval of the specifications.

The many industrial, scientific, medical and home applications of high frequencies, micro-waves, broad-beam optical radiation, lasers and ultra-sound lead to the design of widely-varying devices. One of the first tasks is to classify them according to the power they develop and to the degree of safety for workers and for the public. For each category of apparatus, design and construction standards must be defined which take into account not only its intended use but also the necessary safety requirements. In particular they should ensure that the device cannot materially deliver a needlessly high power (minimization of the emission), that whenever possible the direct radiation be confined or made inaccessible when the power density exceeds a given value, and that the secondary radiation (scattered or leak radiation) is reduced to a negligible value or even prevented in the proximity of device.

Operational protection : In most cases, technical protection measures applied to the source of the radiation should be supplemented by operational protection measures adapted to each situation.

They cannot all be listed here due to their number and to the fact that they vary considerably, depending on the radiation, the type of emitter and the circumstances. Some of the more frequently used measures are given below. . Measures concerning the selection of an appropriate site for the emitter (antennae of high-power radio and radar installations for long-distance lasers etc).

- . Delineation of controlled, restricted or forbidden areas.
- . Special fitting of the working place : appropriate screens, automatic safety devices etc.
- . Identification of forbidden or controlled areas, operation of the devices etc, such as by warning signs and lights.
- . Development and implementation of safety instructions for the use of apparatus at the various working places, including protection against the associated risks (electrical, chemical).
- . Use, in certain circumstances, of individual protection equipment (special clothes, glasses etc).

8. MONITORING AND SURVEILLANCE

8.1 PHYSICAL MONITORING

Ionizing radiation : The physical monitoring of ionizing radiation has been the subject of considerable research and development activity in recent decades. We are now capable of clearly detecting below the irradiation limits the doses received by the different categories of persons exposed. The methods employed may be direct or indirect.

- . Direct methods involve the measurement of the irradiation at the persons themselves by means of individual detectors (dosimeter film, electrometer pens etc).
- . Indirect methods consist in evaluating the irradiation from the measurements taken in the professional or public environment (irradiation or contamination field).

The dosimetry of ionizing radiation has become a discipline in itself. It draws on an extremely wide variety of measuring methods. It enjoys the availability of a large variety of dosimeters allowing instantaneous and cumulative measurements, with extremely wide ranges of use, very high sensitivity and largely sufficient accuracy.

Non-ionizing radiation : With respect to non-ionizing radiation, the situation is completely different. The dosimetry of this radiation is difficult and has not been the subject of investigations as extensive and intensive as those concerning ionizing radiation. Serious difficulties are encountered in obtaining individual detectors. This means that monitoring for non-ionizing radiation can only be collective in general.

Certain estimates are made from measurements on beams in the immediate neighbourhood of the sources, and other estimates are made at a distance, namely in the vicinity of exposed persons in non-ionizing radiation fields. This duality exists in all fields of non-ionizing radiation : radiation fields that are relatively well measured in the absence of the irradiated individual, but considerable difficulty arises in evaluating the energy absorbed by the individual when he enters the same field, especially if this penetration occurs in unforeseeable conditions, outside a specialized laboratory in this type of measurement :

8.2 MEDICAL SURVEILLANCE

Medical monitoring practices are quite different from one country to another, and this is true, not only for non-ionizing radiation but also for ionizing radiation.

In fact, this is a good thing that the workers exposed to irradiation are subjected to similar medical monitoring as that of other workers when the risks of irradiation are high, it is essential to implement specific medical monitoring of the critical tissues and organs for the radiation concerned.

Hence, for ionizing radiation, monitoring should be carried out on the skin, eye, blood-forming tissues, gonads etc.

As to non-ionizing radiation, and in view of the potential radiopathological damage, medical monitoring should essentially cover the skin and the eye. This medical monitoring should include examinations on hiring to judge the aptitude of the worker, periodic examination in the case of sufficient risks, and post-employment examinations if long-term repercussions are possible. The application of the convention and of the recommendations of the International Labour Organization on the Occupational Health Services is highly desirable.

Epidemiological investigations on workers, members of the public and patients could help considerably to achieve progress in the knowledge required for good protection.

II GENERAL CONCLUSIONS

The analysis that we have just made concerning Ionizing Radiations and Non Ionizing Radiations shows at first sight, important differences and poor similarities. But a deeper exam allows to consider a fast future evolution towards a Similar and General System of Protection.

1. DIFFERENCES

The main differences between Ionizing and Non Ionizing Radiations lies in their characteristics, their interactions with matter, their biological effects, their dosimetry.

The characteristics of the two types of Radiations are distinguished by their nature as well as by their energy. Indeed, they cover entirely the electromagnetic spectrum but there are significant differences according to the energy, between X and gamma photons on the one hand and optic radiations and waves on the other hand. But above all, radioactive phenomena with associated problems of contamination only belong to the field of Ionizing Radiations.

Interactions with matter are basically different because of the energy threshold which allows or forbids ionization. Ionizing Radiations alone are likely to reach the structure of atoms and to ionize them. Non Ionizing Radiations only disrupt the molecular structures and lead to physico-chemical reactions. The biological effects ensue from the interactions of radiations and living matter and thus are very different. Both types of radiation can cause deterministic and stochastic effects. But from the viewpoint of protection, the stochastic effects with induction of cancer and of genetic mutations are dominating for the IR, whereas deterministic effects, in particular thermal are essential for NIR.

The metrology of radiations presents analogies or even similar concepts when the flow and the fluences of photons are being considered. On the contrary, dosimetry is significantly different. The dosimetry of Ionizing Radiations is based on the notion of absorbed dose with its derivatives due to the weightings, linked to their nature (equivalent dose), or to the tissue sensitivity (effective dose), as well as to the spreadings in space (collective dose) or in time (committed dose). Indeed, for waves there is the concept of SAR corresponding only to the absorbed dose, but for the entire Non Ionizing Radiations we are still in front of quantities and units linked to the traditional concepts used in optics or for electrical or magnetic fields.

2. SIMILARITIES

On the contrary, there are many similarities between IR and NIR, concerning the sources, the exposures, the situations and the main parameters for the assessment of their effects.

For both types of radiations, natural sources clearly prevail over artificial sources and this matches specially for radioactivity on the one hand and optic radiations on the other hand.

Exposures involve the same categories of people : workers, the public and patients. For both types of radiations we can speak of occupational irradiation, general irradiation and medical irradiation. Note that in both cases the general and medical irradiations are the more important ones.

Situations are also similar when one wants to clarify the problems posed in radiological protection. For IR and NIR, the foreseeable situations result in usual exposures and potential exposures. In the same way, existing situations cover natural and accidental situations.

Lastly, the parameters involved in the analysis of the consequences of exposures are very similar. Some relate to the characteristics of the sources : dimensions, nature and intensity of emission, frequencies and resonances. Others are associated with the space/time modalities of the exposures : source-person geometrical data, time distribution (rate, fractionation, spreading). Finally, the last ones relate to the characteristics of the tissues and organs exposed : structural, functional or dimensional.

3. EVOLUTION

From these differences and these similarities one could believe that two systems of radiological protection must coexist for Ionizing Radiations and Non Ionizing Radiations. In fact one can think that we are tending towards a unique general system with appropriate modes of application. This optimism is based on the historical background of the two fields, the regulatory organization, the reduction of exposures and the checking of the efficiency of protection.

The historical evolution shows a gap in time between protection against ionizing radiations and non ionizing radiations. Both were first concerned with avoiding the deterministic effects with a threshold before limiting the stochastic effects without a threshold. In the same way, the individual approach preceded the collective approach focusing first on occupational exposures and then on general and medical exposures. Finally, protection against Ionizing Radiations was based for a long time upon the couple Limitation-Minimization before changing to the couple Optimization-Limitation; the same evolution is beginning to be noticed for protection against Non Ionizing Radiations.

The general organization of regulations is almost the same for Ionizing Radiations and Non Ionizing Radiations. It is based upon the definition of the field of application of the system of protection. Circumstances below the exemption thresholds are excluded as well as cases of banning of certain practices. On the contrary, the system of protection is applied thanks to regulations specifying the conditions of notification and registering as well as to the authorization and licensing procedures.

The system of reduction of exposures can very well be designed in a similar way for IR and NIR. These general principles are indeed the same : justification, optimization and limitation.

The justification of the activities carried out rests upon the net positive benefit between their advantages and disadvantages.

Optimization of protection consists in making an inventory of all the possible solutions, selecting them and classifying them according to the increase of the net positive benefit; the optimal solution corresponds to the maximum benefit.

The aim of limitation is to assure to each exposed person that the principles of justification and optimization related to the sources by a collective approach do not lead to unacceptable individual exposures. For this we have three types of standards. First the individual limits of exposure which already exist for IR and NIR and which cannot be over-stepped. These limits apply to foreseeable situations such as usual exposures. With transpositions in risk estimation, this concept becomes applicable to potential exposures which require an important effort of radiological safety for IR as well as for NIR. The new concept of Constraint, recommended in Publication ICRP 60, presents the envelope of the optimized solutions and is adapted to each source or category of sources; nothing goes against the fact of spreading its particularly

rich use for NIR as well as for IR. Lastly, the use of reference levels as guides specially adapted to the existing situations concerning natural and accidental exposures can also be considered for NIR as well as for IR with appropriate simple or double values.

Finally, the checking of the efficiency of radiological protection is essential for NIR as well as for IR. Indeed, the quality insurance of radiological protection rest on the statistics of the real exposure of the workers, the public and the patients. For this, it is right to establish and develop a monitoring of the radiological noxious agents either by an ambient dosimetry, rather easy for IR and NIR, or by an individual dosimetry quite easy for IR, but requiring sustained efforts for NIR. This monitoring of noxious agents must normally be completed by a monitoring of the consequences, carried out at the individual level, for workers by the Occupational Health Services, and at the collective level by serious epidemiological studies related to the occupational, general and medical exposures, for IR as well as for NIR.

x

x x

IRPA who, in 1977, had the merit of creating the International Committee of NIR (INIRC), is considering transforming it into an International Commission of Protection Against Non Ionizing Radiations. May this presentation show that we are moving towards a General System of Radiological Protection similar for NIR and IR. I may be optimistic in nourishing this hope, but I think that it is the demonstration of the success of the continuous policy of the IRPA.

RULES AND REGULATION ON RADIATION PROTECTION IN PERU

Eduardo MEDINA GIRONZINI
Sociedad Peruana de Radioprotección

Abstract

This work details the peruvian experience about application of regulatory criteria for elaborating and issuing technical and legal rules addressed to the man and environmental protection against radiation hazards.

The Peruvian Institute on Nuclear Energy (IPEN) is the state organization, decentralized from Energy and Mines Ministry, commissioned for promotion of application and activities in nuclear energy, as well as for control of all radiation sources and its uses, through legal dispositions that establishes the President of IPEN being the National Authority in the nuclear energy scope, therefore has the power for issuing rules, granting licences and authorizations. This functions are carried out through a staff specialized on radiological and nuclear safety, for performing activities of normalization and inspection in a national level.

The regulation on Radiation Protection has had different stages being prominent that related to the promulgation of Organization Law of IPEN in 1977, and the issuing of the Radiation Protection and Installations of Ionizing Radiation Sources Reglamente (1980) through Presidential Resolutions. In 1989 begin a new stage with the issuing of the Radiation Protection Regulation (second version) promulgated by Supreme Decree 018-89-EM/VME after acceptance of 6 State Ministers entailed with matter. This legal regulation asserit to IPEN as regulatory body.

The technical normative is linked enough to issuing of legal regulation and at present are being developed those considered necessary for regulatory control in this country, where there are around 1500 radioactive installations (90% using X rays in medicine), 2 research reactors and approximately 5000 exposed workers.

The current regulation has been based on international recommendations (ICRP, IAEA, etc) and national experience through 15 years. It is showed the organization for control, applicability of regulations, and the perspective for developing this field.

INDEX DES AUTEURS - AUTHOR INDEX

ADAMS, J.A. (NEW ZEALAND)	779	BATAILLE, CHRISTIAN (FRANCE)	164
AHJGREN, L. (SWEDEN)	206	BATTAGLIA, A. (ITALY)	1578
AHMED, J.U. (AUSTRIA)	1464	DAVERSTAM, ULF (SWEDEN)	237
AIGINGER, H. (AUSTRIA)	662	BAYER, ANTON (GERMANY)	408
AIGUEPERSE, JOCELYNE (FRANCE)	22	BAYER, ANTON (GERMANY)	1524
AL-ARBI, S.K. (LYBIA)	853	BEAUVALLET, M. (FRANCE)	904
AL-OMARI, (GERMANY)	408	BEAVER, P.F. (UNITED KINGDOM)	1101
ALBASINI, J. (SOUTH AFRICA)	1765	BECKER, D. EKKEHARD (GERMANY)	1351
ALBUQUERQUE, MARIA (BRAZIL)	144	BECKER, ERNEST (CANADA)	1582
ALCARAZ, G. (ARGENTINA)	1750	BEQUEMIN, M.H. (FRANCE)	289
ALCARES, ROBERTO (BRAZIL)	805	BEISSIERE, Y.M. (FRANCE)	1455
ALFYEROVA, T.M. (U.S.S.R.)	528	BELLINTANI, S. A. (BRAZIL)	805
ALLARD, DAVID J. (U.S.A.)	652	BELLINTANI, S. A. (BRAZIL)	1022
ALLIN, F. (FRANCE)	550	BELOT, Y. (FRANCE)	432
ALLIN, F. (FRANCE)	555	BEN-SHACHAR, BARAK (ISRAEL)	112
ALLOTT, R.W. (UNITED KINGDOM)	1474	BENEDITTINI, MARIE (FRANCE)	698
ALMARCHA, B. (FRANCE)	463	BENINSON, DH. (ARGENTINA)	532
ALMEN, ANJA (SWEDEN)	206	BENJISTAN, G. (FRANCE)	1641
ALPHONSE, L. (FRANCE)	1308	BENOIT, J. (FRANCE)	814
ANDRASI, A. (HUNGARY)	428	BENSIMON, C. (FRANCE)	806
ANDREWS, I. (U.S.A.)	1662	BENSIMON, C. (FRANCE)	1308
ANDRIEU, J. (ARGENTINA)	368	BERARD, P. (FRANCE)	1010
ANDRIEUX, C. (FRANCE)	1420	BERGER, F. (FRANCE)	483
ANGUENOT, F. (FRANCE)	22	BERGQVIST, U. (SWEDEN)	1121
ANSOBORLO, E. (FRANCE)	1010	BERNARD, F.D. (CANADA)	1586
ANTHONI, S. (FRANCE)	1504	BERNARDI, T. (ITALY)	223
ANTHONI, S. (FRANCE)	1447	BERNHARDT, J. (GERMANY)	933
ANTONINI, GERARD (FRANCE)	1424	BERTHOIION, J.F. (FRANCE)	289
ARAUJO, A.M.C. (BRAZIL)	228	BERTI, D. (ITALY)	223
ARCHIMBAUD, Y. (FRANCE)	908	BERTIN, M. (FRANCE)	592
ARTAS, CESAR (ARGENTINA)	356	BERTIN, M. (FRANCE)	1158
ARNOULD, C. (FRENCH POLYNESIA)	1266	BERTIN, M. (FRANCE)	26
AROUA, A. (SWITZERLAND)	491	BERTRON, LUCIEN (FRANCE)	1489
ARROYO, A. (BELGIUM)	1144	BESIU, P. (FRANCE)	1455
AYUZAWA, MIYUKI (JAPAN)	732	BESIU, P. (FRANCE)	1447
AZIMI-GARAKANI, D. (CH)	1566	BESSHO, Y. (JAPAN)	810
BABLET (F), J.P. (FRANCE)	1266	BETIS, JACQUES (FRANCE)	1481
BAD'IN, V. (USSR)	1027	BETSCH, M. (FRANCE)	1404
BADANO, A. (URUGUAY)	313	BHAGWAT, ARUN M. (INDIA)	487
BADREDDINE, A. (THE NETHERLANDS)	326	BINES, W.P. (UNITED KINGDOM)	1101
BAHAL, B.M. (LYBIA)	853	BINES, W.P. (UNITED KINGDOM)	1168
BAIR, WILLIAM J. (U.S.A.)	1053	BTNGO, KAZUYOSHI (JAPAN)	132
BAKOS, J. (HUNGARY)	1140	BTNKS, K. (UNITED KINGDOM)	1176
BANGERA, V.S. (INDIA)	1018	BTNKS, K. (UNITED KINGDOM)	545
BARBRY, F. (FRANCE)	108	BTRAN, MAURICE (CANADA)	763
BARILLON, R. (FRANCE)	658	BLAIN, B. (FRANCE)	1485
BARILLON, R. (FRANCE)	483	BLANC, DANIEL (FRANCE)	459
BARNY, MARIE-HELENE (FRANCE)	57	BLANCHETTE, J. ()	194
BARRACLOUGH, I.M. (UK)	1777	BLECHINGER, JOSEPH (U.S.A.)	367
BARTHE, J. (FRANCE)	479	BOCHICCHIO, F. (ITALY)	1561
BARTHE, J. (FRANCE)	459	BOECKER, B. (U.S.A.)	864
BARTLETT, D.T. (UK)	636	BOECKER, B. (U.S.A.)	896
BASSIGNANI, A. (ITALY)	1286	BOECKER, B. (U.S.A.)	916

BOMBEN, A.M. (ARGENTINA)	1278	CAMPANI, M. (FRANCE)	1404
BONINO, N. (ARGENTINA)	1769	CAMPOS, LETICIA (BRAZIL)	640
BONKA, HANS (GERMANY)	1705	CAMPOS VENUTI, G. (ITALY)	1625
BONNEFOUS, SYLVIANE (FRANCE)	269	CAMPOS VENUTI, G. (ITALY)	1274
BORAK, THOMAS B. (U.S.A.)	1395	CAMPOS VENUTI, G. (ITALY)	443
BORDY, J.M. (FRANCE)	479	CAMPOS VENUTI, G. (ITALY)	1561
BORDY, JEAN-MARC (FRANCE)	459	CAMUS, H. (FRANCE)	86
BORGES, JOSE CARLOS (BRAZIL)	1255	CAMUS, H. (FRANCE)	432
BORGHESI, JOANNA (AUSTRALIA)	951	CAPRA, D. (ITALY)	1355
BORRAS, C. (FRANCE)	1043	CAPRA, D. (ITALY)	1578
BORTOLUZZI, SANDRO (ITALY)	1537	CAPUT, C. (FRANCE)	432
BORTOLUZZI, S. (ITALY)	1327	CAPUT, C. (FRANCE)	86
BOUCHIKHI, A. (FRANCE)	289	CARLSON, R.D. (U.S.A.)	1246
BOUGET, Y.H. (FRANCE)	61	CARON, B. (CANADA)	945
BOUISSET, P. (FRANCE)	463	CARPENTER, R.C. (UNITED KINGDOM)	297
BOULAUD, D. (FRANCE)	673	CARR, F. (U.S.A.)	265
BOULAUD, D. (FRANCE)	82	CARRIER, RAYMOND (CANADA)	348
BOULAUD, D. (FRANCE)	1432	CASTRI, J. (FRANCE)	471
BOURGEOIS, C. (FRANCE)	1529	CAUSSIN, J. (BELGIQUE)	1794
BOUSSARD, (FRANCE)	1162	CENA, M. (ARGENTINA)	1769
BOUSSARD, PIERRE (FRANCE)	1802	CHABOT, G.E. (U.S.A.)	652
BOUJIRIF, E. (FRANCE)	1043	CHAILLET, M.P. (FRANCE)	872
BOUJRUICHE, B. (FRANCE)	479	CHALABREYSSE, J. (FRANCE)	1010
BOUWER, D. (SOUTH AFRICA)	1765	CHAMBAUDET, A. (FRANCE)	1713
BOWKER, KEITH (UK)	1230	CHAMBAUDET, A. (FRANCE)	658
BOWKER, KEITH (UK)	587	CHAMBAUDET, A. (FRANCE)	1432
BRAAK, L. (FRANCE)	463	CHAMBAUDET, A. (FRANCE)	483
BRADY, M.C. (U.S.A.)	1650	CHAMBAUDET (F), A. (FRANCE)	1383
BREDON, P.	550	CHAMBERS, D.B. (CANADA)	1586
BREGEON, B. (FRANCE)	1685	CHAMBERS, D.B. ()	1375
BREGEON, B. (FRANCE)	1485	CHAMEAUD, J. (FRANCE)	550
BRENOT, J. (FRANCE)	57	CHAMPION, GILLES (FRANCE)	499
BREUER, F. (ITALY)	1516	CHANTEUR, JEAN (FRANCE)	1528
BREUER, F. (ITALY)	1089	CHAPUIS, A.M. (FRANCE)	1789
BREY, RICHARD R. (U.S.A.)	1814	CHARBONNEAU, PATRICE (FRANCE)	1810
BRISSAUD, A. (FRANCE)	1677	CHARLAND, P (CANADA)	348
BRISSAUD, A. (FRANCE)	698	CHARLOT, P. (FRANCE)	1424
BRISSAUD, A. (FRANCE)	702	CHARRON, DAVID (CANADA)	763
BRISSAUD, A. (FRANCE)	1447	CHARTIER, J.L. (FRANCE)	620
BROADHEAD, B.L. (U.S.A.)	1650	CHARCAU, JEAN (FRANCE)	136
BROOKS, BARBARA (U.S.A.)	1157	CHARY, J. (FRANCE)	1065
BROQUET, N. (FRANCE)	1713	CHASTEL, R. (FRANCE)	1529
BRUN, C. (FRANCE)	1455	CHAUMONT, J.P. (FRANCE)	1713
BRUNNER, H. H. (SWITZERLAND)	968	CHAUSSADE, J.P. (FRANCE)	53
BULL, R.K. (UNITED KINGDOM)	297	CHEMTOB, M. (FRANCE)	1065
BURBKARDT, B. (GERMANY)	116	CHERFI, M. (FRANCE)	1185
BURBKARDT, B. (GERMANY)	1607	CHEVALIER, CHRISTIAN (FRANCE)	1014
BURKHARDT, J. (GERMANY)	1524	CHEVALIER, A. (FRANCE)	1113
BURKHART, R.L. (U.S.A.)	190	CHOUARD, J.C. (FRANCE)	673
BURNETT, BRUCE M. (U.S.A.)	1520	CISSOKO, G. (FRANCE)	1308
BUTRACUFNO, J.L. (SPAIN)	1729	CIZEL, J.P. (FRANCE)	1447
BUXEROLLE, M. ()	620	CLARKE, ROGER H. (UK)	1039
CABALLERO, K.C. (BRAZIL)	1255	CIECH, A (FRANCE)	1666
CALDAS, LINDA (BRAZIL)	144	CLINTON, J.H. (U.S.A.)	1320
CALDAS, LINDA (BRAZIL)	644	COEQUYT, SERGE (FRANCE)	227
CALDAS, LINDA (BRAZIL)	628	COFFIGNY, HERVE (FRANCE)	904

KODAIRA, J. (JAPAN)	98	LAUTERBACH, U. (GERMANY)	515
KOGA, S. (JAPAN)	396	LAVOIE, C. (CANADA)	211
KOGA, S. (JAPAN)	202	LE BAR, S. (FRANCE)	1294
KOGA, TAEKO (JAPAN)	1721	LE BRETON, MICHEL (FRANCE)	136
KOGA, S. (JAPAN)	608	LE BRONEC, J. (FRANCE)	1335
KOH, DUCK J. (KOREA)	1818	LE BRONEC, J. (FRANCE)	1363
KOIVISTOINEN, A. (FINLAND)	1742	LE BRONEC, J. (FRANCE)	1367
KOIVISTOINEN, A. (FINLAND)	801	LE GUEN, P. (FRANCE)	555
KOJIMA, SHUZO (JAPAN)	1312	LEBARON, L. (FRANCE)	463
KOLIAS, JOHN (GREECE)	439	LEBOULEUX, P. (FRANCE)	1065
KOMLEVA, V.A. (U.S.S.R.)	30	LEBRUN, J.C. (FRANCE)	1420
KOMURA, K. (JAPAN)	1701	LEE, MYUNG CHAN (KOREA)	1818
KONDO, SOHEI (JAPAN)	1721	LEE, D.R. (CANADA)	1305
KONISHI, E. (JAPAN)	810	LEEB, H. (GERMANY)	1524
KOPERSKI, GEORGE (AUSTRALIA)	1057	LEFAURE, CHRISTIAN (FRANCE)	1685
KOSHIDA, K. (JAPAN)	396	LEFAURE, CHRISTIAN (FRANCE)	677
KOSTYUSHOV, E. (U.S.S.R.)	747	LEGARE, J.M. (CANADA)	694
KOSTYUSHOV, E. (U.S.S.R.)	578	LEHMANN, K.H. (GERMANY)	1440
KOSUTIC, DUSKO (YUGOSLAVIA)	219	LEHMANN, K.H. (GERMANY)	1324
KOVTUN, A. (USSR)	1027	LEHMANN, R. (GERMANY)	1611
KRAMER, GARY (CANADA)	321	LEMBO, L. (ITALY)	1625
KRAMER, H. (CANADA)	1697	LEMMELA, H. (CANADA)	273
KRISHNAMURTHI, T.N. (INDIA)	985	LEONARD, R.P. (UK)	70
KRISHNAN, D. (INDIA)	985	LEONARD, A. (BELGIQUE)	1570
KRISTUFEK, H. (AUSTRIA)	662	LERCH, P. (SWITZERLAND)	491
KRONHOLZ, H.L. (GERMANY)	360	LEUNG, JOHN (HONG KONG)	624
KRUCHTEN, D.A. (U.S.A.)	301	LEUSCHNER, A. (SOUTH AFRICA)	1347
KRUGER, JAN (SOUTH AFRICA)	1765	LEVALLOIS, P. (CANADA)	799
KRUGER, P.J. (SOUTH AFRICA)	1765	LEWITZ, J. (GERMANY)	1607
KUBINYI, G. (HUNGARY)	1140	LIANG AN, ZHANG (CHINA)	376
KULIKOV, A. (GERMANY)	1693	LIESER, J. (GERMANY)	1524
KULKARNI, M.S. (INDIA)	1180	LIKHTAREV, I.A. (USSR)	1027
KUMAZAWA, SHIGERU (JAPAN)	1097	LIMSON ZAMORA, MARIA (CANADA)	1085
KUNZMANN, S. (GERMANY)	1607	LIMSON ZAMORA, MARIA (CANADA)	124
KUSAMA, T. (JAPAN)	810	LINDNER, G. (GERMANY)	1693
KUSAMA, T. (JAPAN)	710	LINDNER, G. (GERMANY)	261
KUSAMA, K. (JAPAN)	352	LINDNER, G. (GERMANY)	1709
LABED, V. (FRANCE)	1367	LINIECKI, JULIAN (POLAND)	1193
LAFFAILLE, CLAUDE (FRANCE)	1451	LINSLEY, G.S. (AUSTRIA)	1828
LAHAYE, T. (FRANCE)	479	LINSLEY, G.S. (AUSTRIA)	1733
LAITANO, R.F. (ITALY)	1541	LITVINETS, L.A. (USSR)	1027
LAJOIE, P. (CANADA)	799	LIU, JAMES (U.S.A.)	90
LAKEY, J.R.A. (UK)	964	LIU, J.C. (U.S.A.)	102
LAKEY, J.R.A. (UK)	1149	LOBKE-REINL, A. (GERMANY)	1524
LALIBERTE, LAMBERT (CANADA)	945	LOBRY, P. (FRANCE)	227
LALLEMAND, J. (FRANCE)	592	LOCHARD, JACQUES (FRANCE)	173
LALLEMAND (F), J. (FRANCE)	26	LOCHARD, JACQUES (FRANCE)	241
LAMBROZO, J. (FRANCE)	1113	LOESCH, R.M. (U.S.A.)	1246
LANDOLT, ROBERT R. (U.S.A.)	1814	LOMBARD, J. (FRANCE)	451
LANGEN, K. (SWITZERLAND)	148	LOMBARD, J. (FRANCE)	1633
LANTES, B. (FRANCE)	1455	LOMBART, J. (FRANCE)	412
LANTES, B. (FRANCE)	1447	LOURENCO, M. C. (BRAZIL)	309
LAPLANCHE, AGNES (FRANCE)	541	LOWE, I. (CANADA)	1375
LAPORTE, J. (FRANCE)	1308	LOWE, L. (CANADA)	1586
LAUMOND, A. (FRANCE)	1641	LUBINAS, V. (AUSTRALIA)	779
LAURIDSEN, B. (DENMARK)	583	LUNDGREN, D. L. (U.S.A.)	916

LUYKX, FELIX (LUXEMBOURG)	339	MICINQUEVICH, S. (ARGENTINA)	368
LYTTLE, K. (UNITED KINGDOM)	330	MILAT, J. (ARGENTINA)	368
MADELAINE, G. (FRANCE)	1432	MILCENT, M.C. (FRANCE)	751
MADELMONT, C. (FRANCE)	400	MILICIC, S. (YUGOSLAVIA)	1762
MADHVANATH, U. (INDIA)	1180	MILACIC, S. (YUGOSLAVIA)	736
MADUAR, M.F. (BRAZIL)	1302	MILACIC, S. (YUGOSLAVIA)	1758
MAES, A. (BELGIUM)	1144	MISONOH, JUN (JAPAN)	732
MAGRI, YVON (FRANCE)	1185	MITCHEL, R.E.J. (CANADA)	876
MAHAFFEY, J.A. (U.S.A.)	265	MIYAJIMA, M. (JAPAN)	98
MAIGNE, J.P. (FRANCE)	976	MOBBS, S.F. (UNITED KINGDOM)	1777
MAJBORN, BENNY (DENMARK)	1574	MOBERG, LEIF (SWEDEN)	1681
MALARBET, J.L. (FRANCE)	1133	MOBERG, LEIF (SWEDEN)	237
MALLET, M.W. (U.S.A.)	301	MOLL, J. (FRANCE)	857
MALMQVIST, L. (SWEDEN)	681	MONACELLI, G. (ITALY)	1274
MALORNI, W. (ITALY)	1109	MONNOT, S. (FRANCE)	400
MANCIOPPI, S. (ITALY)	1561	MONTALTO, M. (ITALY)	1327
MANESSE, D. (FRANCE)	400	MONTALTO, M. (ITALY)	1537
MARILLIER, JEAN-CLAUDE (FRANCE)	1153	MONTASSIER, N. (U.S.A.)	1616
MARINKOVIC, O. (YUGOSLAVIA)	219	MONTJOIE, M. (FRANCE)	1308
MARKOVIC, B. (YUGOSLAVIA)	1746	MOODIE, G. (CANADA)	124
MARKOVIC, PETAR (YUGOSLAVIA)	1590	MOORTHY, A.R. (U.S.A.)	1320
MARKOVIC, PETAR (YUGOSLAVIA)	1594	MOREAU, A. (FRANCE)	1658
MARSHALL, T.O. (UK)	636	MOREAU, A. (FRANCE)	186
MARSHALL, T.O. (UK)	1168	MOREAU, A. (FRANCE)	57
MARSHALL (USA), W. (U.S.A.)	937	MORGAN, KARL F. (U.S.A.)	285
MARTENS, L. (BELGIUM)	1144	MORI, A. (ITALY)	1379
MASSE, R. (FRANCE)	908	MORIDI, REZA (CANADA)	1582
MASSERA, G. (ARGENTINA)	1073	MORIN, M.E. (FRANCE)	912
MASSON, B. (FRANCE)	463	MORISHIMA, HIROSHIGE (JAPAN)	1721
MATSUMOTO, M. (JAPAN)	380	MORISHIMA, H. (JAPAN)	160
MATSUNAMI, TADAO (JAPAN)	1290	MORIUCHI, S. (JAPAN)	616
MATTSSON, S. (SWEDEN)	206	MORIUCHI, Y. (JAPAN)	140
MAUBERT, HENRI (FRANCE)	1512	MORLEY, D.R. (CANADA)	1598
MAURICIO, C.L.P. (BRAZIL)	293	MORONI, JEAN-PIERRE (FRANCE)	1528
MAUSHART, RUPPRECHT (GERMANY)	511	MORRISON, D.P. (CANADA)	880
MAUSHART, RUPPRECHT (GERMANY)	416	MOURGJES, M. (FRANCE)	479
MCCALLUM, HAZEL (UK)	1125	MOUTET, ALEXANDRA (FRANCE)	806
MCCALLUM, H.M. (SCOTLAND)	767	MUGGENBERG, B.A. (U.S.A.)	920
MCCALUM, B. (CANADA)	1616	MUGGENBURG, B. A. (U.S.A.)	864
MCDONALD, JOSEPH (U.S.A.)	281	MUGGENBURG, B. A. (U.S.A.)	896
MCDOWELL-BOYER, LAURA (U.S.A.)	1781	MUGGENBURG, B. A. (U.S.A.)	916
MCFADDEN, R. (CANADA)	559	MULTALA, J. (CANADA)	273
MECKBACH, R. (GERMANY)	305	MUNOZ, F. (FRANCE)	1404
MEDINA-GIRONZINI, E. (PERU)	1840	MURAKAMI, HIROYUKI (JAPAN)	132
MEDIONI, R. (FRANCE)	108	MURATA, MIKIO (JAPAN)	467
MEDVEDEV, YU. (U.S.S.R.)	578	MYTTENAERE, C. (BELGIQUE)	1470
MEGUMI, K. (JAPAN)	1290	MYTTENAERE, C. (BELGIQUE)	1689
MEINHOLD, CHARLES (U.S.A.)	1200	McPHAIL, N.J.W. (UNITED KINGDOM)	960
MEINHOLD, C.B. (U.S.A.)	1320	NAATZ, T. (GERMANY)	632
MELI, M.A. (ITALY)	1286	NAGAI, A. (JAPAN)	981
MELIX, N. (FRANCE)	400	NAGARATNAM, A. (INDIA)	392
MEMBREY, F. (FRANCE)	1432	NAGARATNAM, A. (INDIA)	384
MEMBREY, F. (FRANCE)	1383	NAGARATNAM, A. (INDIA)	388
MENEIRIER, FLORENCE (FRANCE)	924	NAGLE, C. (ARGENTINA)	892
MERCIER, J. (FRANCE)	814	NAGLE, C. (ARGENTINA)	868
MEWHINNEY, J. A. (U.S.A.)	920	NAIK, G.R. (INDIA)	487

NAIM, E. (ISRAEL)	112	OUVRARD, R. (AUSTRIA)	1027
NAKAMURA, T. (JAPAN)	380	OWEN, R.J. (AUSTRALIA)	947
NAKAMURA, TAKASHI (JAPAN)	152	PAGES, P. (FRANCE)	451
NAKAMURA, C. (JAPAN)	1412	PAGES, P (FRANCE)	412
NAKAMURA, M. (JAPAN)	608	PAILE, W. (FINLAND)	801
NAKASHIMA, YOSHIYUKI (JAPAN)	981	PALACIOS, E. (ARGENTINA)	1073
NAKAZAWA, M. (JAPAN)	1701	PALACIOS, M.A. (ARGENTINA)	666
NARAYANAN, K.K. (INDIA)	985	PAPASTEFANOU, C. (GREECE)	1725
NASAZZI, N.B. (ARGENTINA)	892	PARADISI, S. (ITALY)	1109
NASAZZI, N.B. (ARGENTINA)	868	PARKS, C.V. (U.S.A)	1650
NASHIMURA, Y. (KOREA)	571	PARMENTIER, N. (FRANCE)	463
NAZARAIT, A.M. (U.S.A.)	652	PARMENTIER, N. (FRANCE)	806
NEMETH, I. (HUNGARY)	428	PARMENTIER, C. (FRANCE)	806
NENOT, J.C. (FRANCE)	806	PARRHOMENKO, V.A. (USSR)	1027
NEY, CESAR (BRASIL)	670	PATHAK, BHAWANI (CANADA)	600
NEZNAL, M. (CZECHOSLOVAKIA)	1359	PATTERSON, M. (U.S.A)	925
NEZNAL, M. (CZECHOSLOVAKIA)	1359	PEBARA, W. (GERMANY)	515
NGUYEN, V.D. (FRANCE)	463	PEIO, T. (ROMANIA)	1371
NIKEZIC, D. (YUGOSLAVIA)	1590	PELLERIN, PIERRE (FRANCE)	1528
NIKEZIC, D. (YUGOSLAVIA)	1594	PENNEROUX, M. (FRANCE)	1162
NIKOLIC, V. (YUGOSLAVIA)	1762	PEREVOZNIKOV, O.N. (USSR)	1027
NIKOLIC, V. (YUGOSLAVIA)	1758	PEROTIN, JP (FRANCE)	1424
NIKULA, K.J. (U.S.A.)	864	PERROUX, A. (FRANCE)	400
NISHIO, JOHN (CANADA)	763	PERSSON, LARS (SWEDEN)	929
NISHIWAKI, Y. (JAPAN)	160	PERSSON, LARS (SWEDEN)	1222
NISHIWAKI, Y. (JAPAN)	1721	PERSSON, LARS (SWEDEN)	1681
NISHIYA, TAKEO (JAPAN)	503	PERSSON, LARS (SWEDEN)	1343
NISIZONO, T. (JAPAN)	1412	PERSSON, B.A. (SWEDEN)	681
NIWA, T. (JAPAN)	495	PESCAYRE, G. (FRANCE)	857
NIWA, TAKEO (JAPAN)	1721	PETIT, S. (FRANCE)	227
NOBKE, D. (GERMANY)	1524	PFEIFFER, W. (GERMANY)	1693
NOCENTE, M. (ITALY)	1327	PFOB, HELMUT (GERMANY)	1754
NOCENTE, MAURO (ITALY)	1537	PFOB (G), H. (GERMANY)	26
NOMURA, TAMOTSU (JAPAN)	503	PHILLIPS, FRANK (UK)	1474
O'DONNELL, P.	1508	PHILLIPS, B.G. (CANADA)	1598
O'RIORDAN, M.C. (UK)	1331	PIECHOWSKI, J. (FRANCE)	814
O'RIORDAN, M.C. (U.S.A)	591	PIERI, J. (FRANCE)	751
OAKES, N.J. (UNITED KINGDOM)	960	PIERMATTEI, S. (ITALY)	1625
OBAYASHI, H. (JAPAN)	98	PIERMATTEI, S. (ITALY)	1541
OBAYASHI, H. (JAPAN)	140	PIERMATTEI, S. (ITALY)	1274
OGAWA, YOSHIHIRO (JAPAN)	1316	PIERMATTEI, S. (ITALY)	1561
OGRIS, E. (AUSTRIA)	662	PIESCH, E. (GERMANY)	116
OGURA, TAKESHI (JAPAN)	503	PIESCH, E. (GERMANY)	1607
OHTA, KATUMASA (JAPAN)	352	PLACEK, V. (CZECHOSLOVAKIA)	182
OHTA, M. (JAPAN)	810	POELAERT, M. (BELGIQUE)	1794
OLIVEIRA, C.A.N. (BRAZIL)	309	POLETIKO, C. (FRENCH POLYNESIA)	1266
OLIVEIRA, S.M.V. (BRAZIL)	228	POMROY, CHRIS (CANADA)	727
OLIVEIRA, A.A. (ARGENTINA)	666	PONA C., (ITALY)	1541
OLIVEIRA, A.A. (ARGENTINA)	1278	PONCY, J.L. (FRANCE)	908
OLIVEIRA FILHO, D.S. (BRASIL)	670	POOK, E.A. (UNITED KINGDOM)	636
ONODERA, JUNICHI (JAPAN)	1412	POPOV, I. (U.S.S.R)	747
ORITO, T. (JAPAN)	202	POPOV, I. (U.S.S.R)	578
CRITO, T. (JAPAN)	608	POPOVIC, D. (YUGOSLAVIA)	1717
ORITO, T. (JAPAN)	396	POPOVIC, D. (YUGOSLAVIA)	612
OSWATH, IOLANDA (ROMANIA)	1545	PORTAL, G. (FRANCE)	1061
OUVRARD, R. (AUSTRIA)	253	PORTAL, G. (FRANCE)	479

POSNY, F. (FRANCE)	620	ROBE, M.C. (FRANCE)	1335
PRADEL, J. (FRANCE)	1416	ROBE, M.C. (FRANCE)	1367
PRETRE, S. (SWITZERLAND)	491	ROBE, M.C. (FRANCE)	1363
PRICE, R. (U.S.A)	1262	ROBEAU, D. (FRANCE)	1308
PRIGENT, R. (FRANCE)	1065	ROBEAU, D. (FRANCE)	1189
PRINCE, JOHN ()	367	ROBINET, G. (FRANCE)	471
QUEINNEC, ERIC (FRANCE)	722	ROGANI, A. (ITALY)	1516
QUEIRAZZA, G. (ITALY)	1578	ROGANI, A. (ITALY)	443
QUEIRAZZA, G. (ITALY)	1355	ROHNSCH, W. (GERMANY)	1611
QUESNE, B. (FRANCE)	1010	ROJAS, C. (ARGENTINA)	309
RAABE, OTTO G. (U.S.A)	718	ROLLIN, PHILIPPE (FRANCE)	677
RAFFOUX, C. (FRANCE)	873	ROLIM, J. (FRANCE)	592
RAGAZZINI, L. (ITALY)	443	ROMERO, L. M. (U.S.A.)	920
RAHAPLEN, A. (FRANCE)	1308	RONGIER, P. (FRANCE)	1512
RAHOJA, T. (FINLAND)	801	RONNHAAU, C. (BELGIQUE)	1689
RAJAN, K.K. (INDIA)	783	ROSELLI, C. (ITALY)	1286
RALL, A.M. (GERMANY)	1324	ROSENBERG, A. (FRANCE)	1529
RAMONI, C. (ITALY)	1136	ROSENSTEIN, M. (U.S.A.)	190
RANCILLAC, F. (FRANCE)	451	ROSENSTEIN, M. (U.S.A.)	1520
RANCILLAC, F. (FRANCE)	412	ROSS, BRIAN. (GREAT BRITAIN)	1558
RANNOU, A. (FRANCE)	1335	ROSS, BRIAN (UNITED KINGDOM)	1637
RANNOU, A. (FRANCE)	1367	ROTINER, B. (FRANCE)	656
RANNOU, A (FRANCE)	1363	ROUSSEL, CLAUDE (FRANCE)	1674
RACUL, H. (FRANCE)	1129	ROUSSEL, S. (FRANCE)	1298
RAPHALEN, A. (FRANCE)	550	ROX, A. (GERMANY)	1621
RAPHALEN, A. (FRANCE)	555	ROY, COLIN (AUSTRALIA)	759
RAPHALEN, A. (FRANCE)	1189	ROY, M. (FRANCE)	289
RASMUSSEN, IEN (CANADA)	727	ROY, COLIN (AUSTRALIA)	791
RATNA, P. (INDIA)	1180	RUDRAN, K. (INDIA)	1018
REDDY, A. R. (INDIA)	384	RUDRAN, K. (INDIA)	487
REGIBEAU, A. (BELGIQUE)	1794	RUDRAN, K. (INDIA)	685
REGUIA, D. (GERMANY)	515	RYTOMAA, T. (FINLAND)	801
REICHELT, A. (GERMANY)	1351	SACHDEV, R.N. (INDIA)	783
RENAUD, LOUIS (CANADA)	194	SADAGOPAN, G. (INDIA)	685
RENIER, S. (FRANCE)	424	SAHYUN, ADELTA ()	805
REPACHOLI, M. (AUSTRALIA)	1031	SAITO, K. (JAPAN)	616
REPIN, V.S. (USSR)	1027	SAKUMA, Y. (JAPAN)	140
REUTHER, G. (GERMANY)	360	SAKUMA, Y. (JAPAN)	98
RICHARDS, A.G. (UK)	775	SALOMAA, SJSKO (FINLAND)	1742
RICHARDS, A.G. (UK)	1172	SALOMAA, SJSKO (FINLAND)	801
RIDOUX, PH. (FRANCE)	1677	SAMPAOLO, A. (ITALY)	1578
RIDOUX, P. (FRANCE)	1504	SANDOR, G. N. (ROMANIA)	1371
RIDOUX, P. (FRANCE)	1447	SANTINI, M.T. (ITALY)	1109
RIECK, W. (GERMANY)	507	SANTOS, R. (BRAZIL)	805
RIGHETTI, M. (ARGENTINA)	309	SARBACH, J. (FRANCE)	1266
RINGLING, M. (GERMANY)	516	SARIBALAS (A), J. (AUSTRALIA)	779
RINGOT, CLAUDE (FRANCE)	1641	SAIO, (JAPAN)	140
RINGOT (F), C. (FRANCE)	1633	SAUMON, P. (FRANCE)	1485
RISICA, S. (ITALY)	443	SAURLIN, P. (FRANCE)	1447
RISICA, S. (ITALY)	1274	SAURIN, P. (FRANCE)	1455
RISICA, S. (ITALY)	1561	SAUVE, A.M. (FRANCE)	1308
RIVERS, J. (AUSTRALIA)	791	SAWANI, J.V. (INDIA)	1018
RO, SECUNG (KOREA)	1818	SCARPA, G. (ITALY)	1625
ROBB, JD (UNITED KINGDOM)	1226	SCHELL, B. (GERMANY)	261
ROBB, J.D. (UNITED KINGDOM)	1077	SCHLEICHER, H. (GERMANY)	507
ROBBINS, J.A. (GERMAY)	1693	SCHLOSSER, H. (GERMANY)	516

SCHLUMBERGER, M. (FRANCE)	806	STAGER, R.H. (CANADA)	1586
SCHMIDT, P. (GERMANY)	829	STAIMESSE, JACQUES (FRANCE)	702
SCHNEIDER, T. (FRANCE)	241	STEGER, F. (AUSTRIA)	253
SCHNEIDER, T. (FRANCE)	1077	STEGER, F. (AUSTRIA)	1027
SCHNEPEL, G.H. (GERMANY)	520	STEINHAUSLER, F. (AUSTRIA)	1549
SCHULTE, E (FRANCE)	1512	STEINKOPFF, T. (GERMANY)	632
SCHUTZ, J. (GERMANY)	360	STEVENSON, J M (UK)	1230
SEEWALD, O. (GERMANY)	1693	STEVENSON, G.R. (SWITZERLAND)	829
SEGUR, PIERRE (FRANCE)	459	STEYN, A. (SOUTH AFRICA)	1347
SEIFERT, H. (GERMANY)	1607	STOICI, S.D. (ROMANIA)	1371
SEVC, J. (CZECHOSLOVAKIA)	182	STOJANOVIC, D. (YUGOSLAVIA)	1738
SHANDALA, M (U.S.S.R.)	955	STOKELL, PJ (U.K)	1077
SHANDALA, N.K. (U.S.S.R.)	30	STRAFACE, F. (ITALY)	1109
SHAW, K.B. (UNITED KINGDOM)	1637	STRAMBI, ERNESTO (ITALY)	1773
SHAW, K.B (UNITED KINGDOM)	1646	STREUBEL, G. (GERMANY)	1607
SHAW, K.B. (UNITED KINGDOM)	1633	STRICKER, LAURENT (FRANCE)	1489
SHEPHERD, J.P. (UK)	1242	STRONG, R. (UNITED KINGDOM)	1176
SHI, Y. (U.S.A)	1616	STRYDOM, R. (SOUTH AFRICA)	1347
SHIBUYA, M. (JAPAN)	1312	STUCHLY, MARIA (CANADA)	1117
SHIGETA, YUKIHIRO (JAPAN)	1654	SUGIER, A. (FRANCE)	1047
SHIN, HEE (KOREA)	1818	SULEIMAN, O.H. (U.S.A.)	190
SIEGRIST, M. (FRANCE)	463	SUN, LIN-SHEN (U.S.A)	1320
SILIBELLO, C. (ITALY)	1355	SUNDARARAJAN, A.R. (INDIA)	985
SILINI, GIOVANNI	1	SURYAWANSHI, S.A. (INDIA)	860
SIMERAY, J. (FRANCE)	1713	SUSANNA, A.F. (ITALY)	1274
SIMONET, M.L. (FRANCE)	806	SUZUKI, T. (JAPAN)	981
SIMS, C.S. (U.S.A.)	90	SUZUKI, S. (JAPAN)	608
SINCLAIR, WARREN K. (USA)	533	SUZUKI, S. (JAPAN)	396
SINGH, GURINDER (INDIA)	1793	SUZUKI, S. (JAPAN)	202
SINGH, J. (INDIA)	1603	SUZUKI, K. (JAPAN)	1312
SINGH, L. (INDIA)	1603	SWARUP, G. (INDIA)	783
SINGH, S. (INDIA)	1603	SYLVESTRE, R. (CANADA)	945
SINGMIN, ANDREW (CANADA)	1629	SZABO, L. (HUNGARY)	1140
SINNAEVE, J.	1469	TAJA, M.R. (ARGENTINA)	892
SJOEBLOM, K.L. (AUSTRIA)	1733	TAJA, M.R. (ARGENTINA)	868
SLAPER, H. (THE NETHERLANDS)	795	TAKESHITA, G. (JAPAN)	202
SLINEY, DAVID (U.S.A)	925	TAKEUCHI, A. (JAPAN)	202
SLINEY (USA), D.H. (U.S.A.)	937	TAKEUCHI, A. (JAPAN)	396
SLOVAK, A.J.M. (UK)	545	TAKIMOTO, S. (JAPAN)	1312
SMARDA, J. (CZECHOSLOVAKIA)	1359	TAKITA, A. (JAPAN)	1312
SMELCEROVIC, M. (YUGOSLAVIA)	1717	TARALL, G. (FRANCE)	1685
SMITH, S.K. (U.S.A.)	265	TAUHATA, L. (BRASIL)	670
SNIHS, J.O. (SWEDEN)	34	TAUHATA, L. (BRASIL)	989
SNIPES, M. B. (U.S.A.)	896	TEISSIER, MARC (FRANCE)	818
SOCIE, G. (FRANCE)	872	TERAI, KUNIO (JAPAN)	1701
SOGAARD-HANSEN, J. (DENMARK)	583	TESTA, CORRADO (ITALY)	1286
SOHIER, A. (BELGIUM)	420	TESTINI, Y. (FRANCE)	424
SONTAG, M. (FRANCE)	424	TESTONI, GIOVANNI (ITALY)	223
SORDI, G.M.A.A. (BRAZIL)	1081	TEUNEN, D. (LUXEMBOURG)	169
SOULATGES, DOMINIQUE (FRANCE)	1674	THAMPAN, S. (INDIA)	1018
SOULTAGES, DOMINIQUE (FRANCE)	1002	THAMPAN, S. (INDIA)	487
SOYER, C. (FRANCE)	86	THERIAULT, BERTRAND (CANADA)	78
SPAN0, F. (ARGENTINA)	1073	THEZEE, CHRISTIAN (FRANCE)	689
SPEZZANO, P. (ITALY)	1537	THIRY, YVES (BELGIQUE)	1689
SPEZZANO, P. (ITALY)	1327	THOMAS, PIERRE (FRANCE)	563
ST. AUBIN, M.J. (CANADA)	1305	THOMAS, RALPH (U.S.A.)	825

THOMAS, P. (FRANCE)	814	VIRK, H.S. (INDIA)	1603
THOMASZ, E. (ARGENTINA)	1734	VOELZ, GEORGE (U.S.A)	714
THUROCZY, G. (HUNGARY)	1140	VOITCHEK, I.V. (U.S.S.R)	747
TIRMARCHE, M. (FRANCE)	550	VOLTCHER, I. (U.S.S.R)	578
TIRMARCHE, M. (FRANCE)	555	VUILLAUME, MONIQUE (FRANCE)	722
TIRMARCHE, M. (FRANCE)	1189	VUORINEN, ANTTI (FINLAND)	1270
TOMASEVIC, M. (YUGOSLAVIA)	219	WADE, J.P. (UNITED KINGDOM)	372
TOMMASINO, L. (ITALY)	1561	WADMAN III, W. (U.S.A.)	1662
TOMOOKA, MASASHI (JAPAN)	467	WAHL, U. (GERMANY)	261
TORRY, G. (ITALY)	1561	WAKEFORD, R. (UNITED KINGDOM)	545
TOYAMA, H. (JAPAN)	202	WAKEFORD, R. (UNITED KINGDOM)	1176
TRACY, B.L. (CANADA)	1697	WALL, B.F. (UNITED KINGDOM)	344
TRANCREDI, F. (ITALY)	443	WANG, S. (CHINA)	1391
TRAVAILLON, R. (FRANCE)	471	WARMING, LISBETH (DENMARK)	583
TRIVEDI, A. (CANADA)	743	WARRET, G. (FRANCE)	1113
TRIVEDI, A. (CANADA)	455	WASIOJEK, P. (U.S.A)	1616
TRIVEDI, A. (CANADA)	876	WASSON, M. (UNITED KINGDOM)	1149
TROMBINI, J.L. (FRANCE)	698	WATABE, H. (JAPAN)	380
TROMBINI, J.L. (FRANCE)	702	WATARI, K. (KORFA)	571
TROMBINI, J.L. (FRANCE)	1504	WEADOCK, A.A. (U.S.A.)	1233
TROMM, W. (GERMANY)	408	WEBB, G.A.M. (UNITED KINGDOM)	1226
TRONOV, V.A. (U.S.S.R.)	528	WEBB, G.A.M. (UNITED KINGDOM)	344
TSD, MAN-YIN W. (HONG KONG)	624	WEBER, C. (FRANCE)	1447
TSUJIMOTO, T. (JAPAN)	1316	WEICHLEIN, B. (FRANCE)	463
TSUJIMURA, N. (JAPAN)	152	WEISE, HANS-PETER (GERMANY)	210
TSURUTA, TAKAO (JAPAN)	495	WEISS, W. (GERMANY)	1524
TSUTSUMI, MASAHIRO (JAPAN)	616	WELCH, S.J. (CANADA)	1305
TUBERTINI, O. (ITALY)	223	WERNER, M. (GERMANY)	1524
TYAPTIN, A. (U.S.S.R)	747	WERNLI, C. (SWITZERLAND)	148
TYAPTIN, A. (U.S.S.R)	578	WHITLOCK, G.D. (ENGLAND)	128
TYMEN, G. (FRANCE)	1363	WIHOM, R. (SWEDEN)	1121
ULANOVSKY, S. (USSR)	1027	WIFIAND FAJARDO, P. (BRAZIL)	604
UNRAU, P. (CANADA)	880	WIGGS, L.D. (U.S.A)	714
URABE, I. (JAPAN)	1316	WIHELM, C. (GERMANY)	261
URBAN, J. (HUNGARY)	428	WILHELM, C. (GERMANY)	1709
VALENTIN, JACK (SWEDEN)	198	WILKINSON, GREGG (U.S.A.)	549
VALENTIN, JACK (SWEDEN)	681	WILKINSON, H.I. (UK)	1474
VALENTY, M. (FRANCE)	806	WILLIAMS, G. (U.S.A.)	190
VALLEY, J.F. (SWITZERLAND)	215	WILLIAMS, M. (UNITED KINGDOM)	1168
VALLEY, J.F. (SWITZERLAND)	491	WILSON, JOHN (U.S.A)	1557
VAN HEES, M. (BELGIQUE)	74	WILSON, A.T. (AUSTRALIA)	947
VAN NETTEN, C. (CANADA)	1598	WILSON, CHRISTOPHER (UK)	1646
VANDECASTEELE, C. M. (BELSIQUE)	74	WILSON, JOHN J. (USA)	1620
VECCHIA, P. (ITALY)	1136	WISLON, C.K. (UNITED KINGDOM)	1637
VENDATARAMAN, G. (INDIA)	685	WITTIER, C. (GERMANY)	1524
VENKATESWARAN, T.V. (INDIA)	1180	WOIBERT, G. (FRANCE)	1158
VENTURINI, L. (BRAZIL)	1302	WOLFF, J. (GERMANY)	1709
VERGNES, R. (FRANCE)	227	WOOD (A), M.P. (AUSTRALIA)	779
VERNOIS, Y. (FRANCE)	924	WOODHOUSE, J.A. (UK)	1257
VERSCHAEVE, L (BELGIUM)	1144	WUI, I.S. (KOREA)	571
VETIER, R.J. (U.S.A)	591	WUNDERER, M. (GERMANY)	261
VICENTE, ROBERTO (BRASIL)	1022	YABUTA, H. (JAPAN)	1412
VIKTORSSON, C. (FRANCE)	249	YABUTA, H. (JAPAN)	1654
VILGIS, M. (GERMANY)	116	YAMAGUCHI, YASUHIRO (JAPAN)	1237
VILKAMO, OLLI (FINLAND)	1270	YAMAMOTO, HIDEAKI (JAPAN)	467
VIRGILI, M. (ITALY)	1773	YAMAMOTO, T. (JAPAN)	98

YAMAMOTO, T. (JAPAN)	140
YAMANISHI, HIROKUNI (JAPAN)	1387
YAMANO, T. (JAPAN)	152
YOKOSUKA, Y. (JAPAN)	1412
YOSHIDA, MAKOTO (JAPAN)	132
YOSHIZAWA, MICHIO (JAPAN)	1237
YOSHIZAWA, YASUO (JAPAN)	810
ZANNOLI, R. (ITALY)	223
ZEEVAERT, TH. (BELGIUM)	1396
ZETTWOOG, P. (FRANCE)	1416
ZETTWOOG, P. (FRANCE)	1432
ZHANG, JINGYUAN (CHINA)	1391
ZHU, HONGDA (CHINA)	1391
ZIBOLD, GREGOR (GERMANY)	1709
ZIELCZYNSKI, M. (POLAND)	156
ZIELINSKI, J. (CANADA)	1085
ZIEMER, P. (U.S.A)	1205
ZOMBORI, P. (HUNGARY)	428